

# ILLUSTRATED PARTS BREAKDOWN

# PDP 11/50 16 BIT COMPUTER (Basic)

## HOW TO USE THE IPB

### GENERAL

This IPB is compiled following the organization and nomenclature of the engineering drawing structure.

### MAJOR ASSEMBLY LOCATOR

The Major Assembly Locator (first illustration) is an index that provides a description and a figure reference for all illustrations used in this manual.

### INDENTED PARTS LIST

This manual identifies each assembly being broken down (figure reference callout), and all parts of that assembly. Further breakdown of an assembly is shown by an asterisk (\*) preceding the item callouts in the Description Column. The number of asterisks preceding an item is used to denote the subordination of that item with respect to the Major Assembly. A single asterisk preceding an item description indicates that the item is part of the major assembly being illustrated. Items that are subordinate to single asterisk items, are denoted by two asterisks (\*\*), and immediately follow the related single asterisk item. Additional asterisks are used, as required, to denote further subordination. This system of part identification, provides a means for the user to identify the next higher assembly item and make alternate selections for parts when the required replacement part or assembly is not immediately available.

### COLUMN CALLOUT DESCRIPTION

**Figure & Item** - Indicates the figure number and item number of each part.

**Description** - Lists the name of the part and pertinent specifications (when required). Asterisks preceding the description denote the subordination of the part to the next higher assembly.

**DEC Part No.** - Lists the DEC part ordering number. A blank in this column indicates a DEC part number was not assigned at the time of publication.

**ECO Cut-In** - The notation at the top of this column indicates the ECO level of the system (option), at which the IPB was initially prepared. Subsequent ECO level designations, that modify existing parts or add new parts to the device, are inserted in the ECO Cut-In column next to the part that is added or modified. A bracket ([]) preceding the item description is used to indicate the parts affected by ECO's.

**Vendor Code/Part No.** - Indicates vendor parts that are not stocked by DEC. Refer to the Field Service Spares Catalog (vendor part number to DEC part number) for the vendor code cross-reference.

**Used On Code** - Letters in this column correspond to the variation codes assigned in Figure 1. Parts with an Alpha notation(s) are used only in those option variations. A blank indicates that the part is used on all option variations.

**Ref Fig No.** - A cross reference between illustrations. For each Major Assembly, the number in this column denotes the figure of the next higher assembly. For all subassemblies, the number in this column denotes the figure showing additional detailed breakdown.

### SYMBOL USAGE

**Hardware Designators** - Alpha designators for screws (S), washers (W), nuts (N), and retaining rings (R) are inserted after the item number callouts on the illustration when stacked item numbers are used.

**Attaching Hardware** - The @ symbol is inserted before any part that is used as attaching hardware. Attaching hardware is denoted as those parts that are not an integral part of the referenced assembly.

**(NFR) Not Field Repairable** - The (NFR) symbol is inserted after any assembly that is not to be field dismantled.

**Other Symbols** - Any other symbols that are required for kits, accessories, etc., will be explained and appear as part of the item description.

## REVISION HISTORY

PRINTING	ECO LEVEL	DATE	PAGES AFFECTED
1st Printing	PDP 11/50 00000-00004 H960C 00000 00001 H950 00100 00102 H950A 00000 00001 54 09684 00000 00005 70 08784 00000 00002 70 09540 00000 00000	10 8-74	N A

Copyright © 1974, by Digital Equipment Corporation

DEC reserves the right, without notice, to make substitutions and modifications in the specifications of products documented in this manual and further reserves the right to withdraw any of these products from the market without notice.

DEC is not responsible for errors which may appear in the technical description (including illustrations and photographs) of the products covered by this manual.

None of the descriptions contained in this manual imply the granting of any license whatsoever to make, use or sell equipment constructed in accordance therewith.

Printed in U.S.A.

PDP11/50 - 1

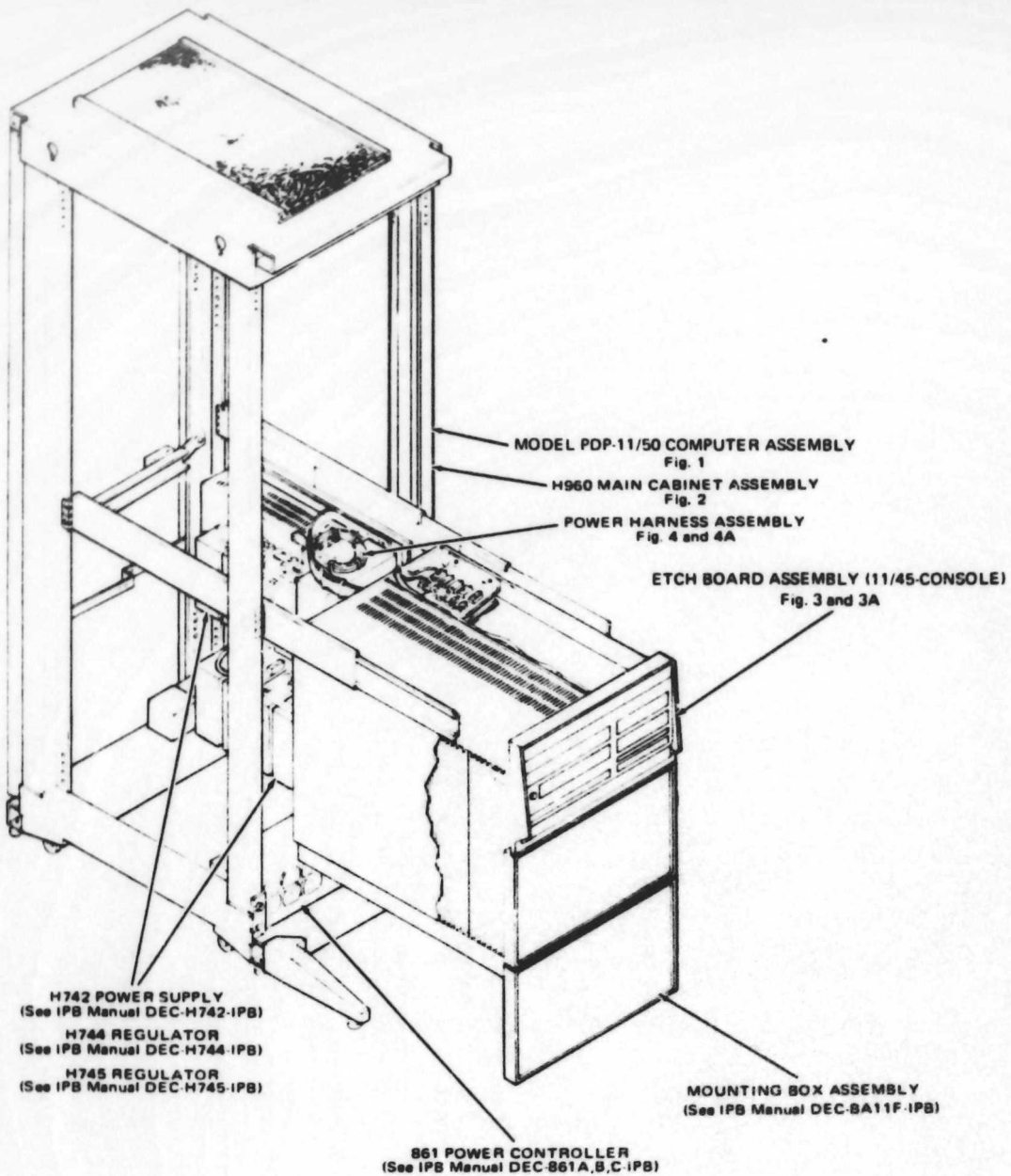

NOTE: DOOR AND PANELS NOT SHOWN FOR PURPOSE OF CLARITY

Major Assembly Locator, PDP-11/50 Computer

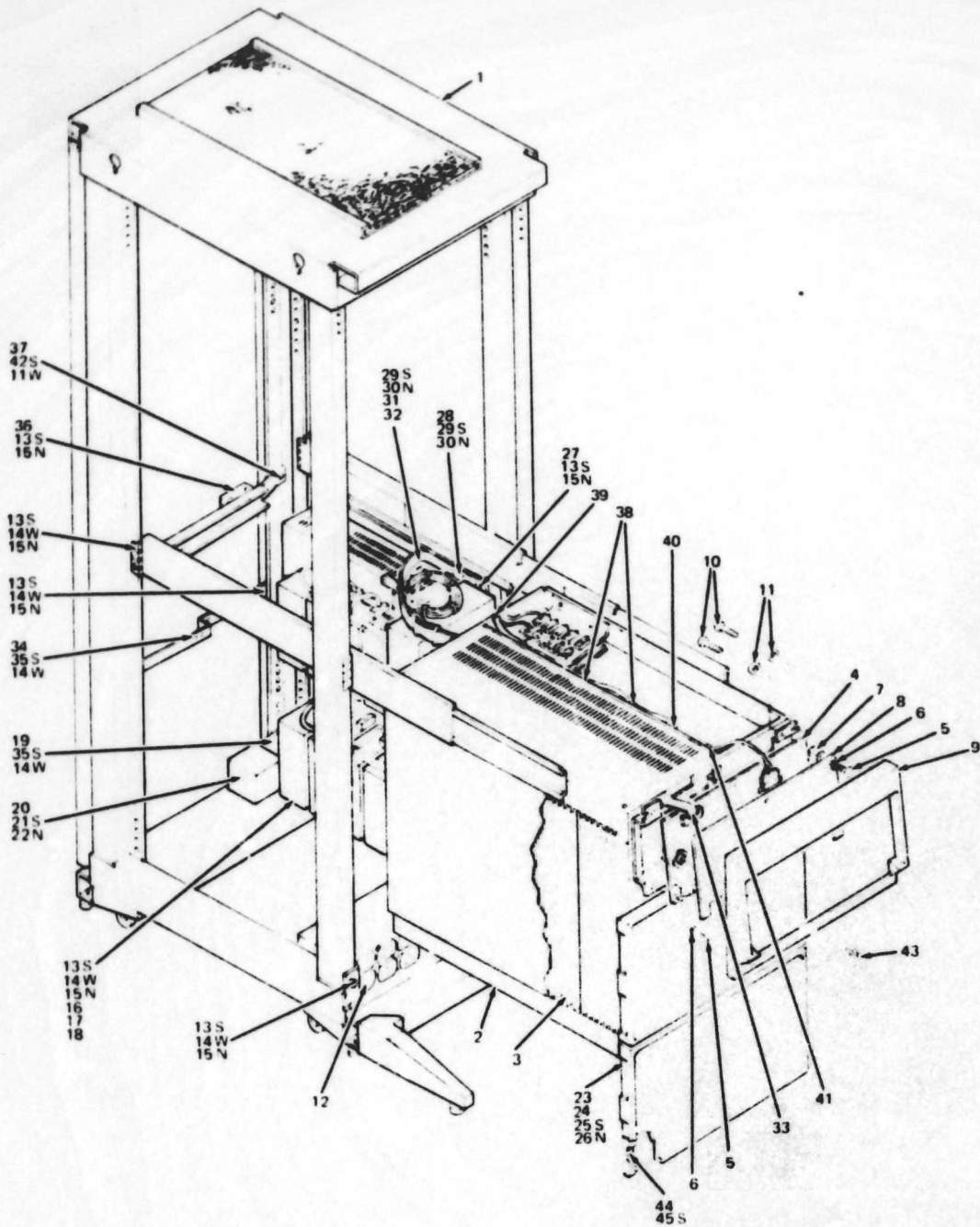

NOTE: DOOR AND PANELS NOT SHOWN FOR PURPOSE OF CLARITY

Figure 1. Model PDP-11/50 Computer Assembly (16 Bit)



IPB-11/50

PDP 11/50-3

FIG & ITEM NO.	DESCRIPTION	DEC PART NO.	ECO CUT-IN PDP 11/50 00000	USED ON CODE	VENDOR		REF FIG NO.
					CODE	PART NO.	
1--	MODEL PDP 11/50 COMPUTER ASSY (16 BIT)						
	Code A used on PDP 11/50 CA (Basic Assy) 115V	PDP-11/50-CA		A			
	Code B used on PDP 11/50 CB (Basic Assy) 230V	PDP-11/50-CB		B			
1	*CABINET ASSEMBLY (PDP 11)	H960CD					2
2	*MOUNTING BOX ASSEMBLY	BA11 FA				See Manual DEC BA11-F-1PB	
3	*PROCESSOR (16 Bit) (Refer to Module Utilization Dwg E MU KB11 A 01)	KB-11A					
	** Wired Assembly (KB11 A)	70 0887 00					
4	*ETCH BOARD ASSY (11/45 Console)	54-09684-00					3
5	*Screw, Phi Pan Hd No. 8 32 x .31 (deleted)	90-06021-02					
	*Screw, Phi Pan Hd No. 6 32 x .31 (added)	90-06021-01					
6	*Washer, Lock Int Tooth No. 6	90-06633-00					
7	*Spacer, Mex Special	90-09120-01					
8	*Panel, Indicator	74-09271-01					
9	*Bezel	12-10710-00					
10	*Screw, Phi Pan Hd No. 8 32 x 50	90-06039-01					
11	*Washer, Lock Ext Tooth No. 8	90-08072-00					
12	*POWER CONTROL ASSEMBLY (115V)	861-A		A		See Manual DEC 861A,B,C-1PB	
	*POWER CONTROL ASSEMBLY (230V)	861-B		B		See Manual DEC-861A,B,C-1PB	
13	*Screw, Phi Pan Hd No. 10-32 x .62	90-06074-01					
14	*Washer, Lock Ext Tooth No. 10	90-07651-00					
15	*Nut, Tinnerman	90-07786-00					
16	*POWER SUPPLY ASSEMBLY (115V)	H742-A		A		See Manual DEC-H742-1PB	
	*POWER SUPPLY ASSEMBLY (230V)	H742B		B		See Manual DEC H742-1PB	
17	*REGULATOR ASSEMBLY (+5V)	H744-00				See Manual DEC-H744-1PB	
18	*REGULATOR ASSEMBLY (-15V)	H745-00				See Manual DEC-H745-1PB	
19	*Bracket, Meter Mounting	74-09622-00					
20	*Meter, Elapsed Time (M1906)	12-01208-00		A			
	*Meter, Elapsed Time (M1908) (deleted)	12-02270-00		B			
	*Meter, Elapsed Time (M1905) (added)	12-02234-00	00004	B			
21	*Screw, Phi Pan Hd No. 4 40	90-08301-01					
22	*Nut, Kep No. 4 40	90-06557-00					
23	*Bracket, Mounting, 10-1/2 inch panel	74-09289-00					
24	*Cover, Panel 10-1/2 inch	H950 QA					
25	*Screw, Phi Pan Hd No. 8-32 x .38	90-06037-01					
26	*Nut, Kep No. 8-32	90-06563-00					
27	*Bracket, Harness Support	74-09445-00					
28	*Plate, Support	74-09447-00					
29	*Screw, Phi Pan Hd No. 10 32 x .50	90-06073-01					
30	*Nut, Kep No. 10 32	90-06565-00					
31	*HARNESSES, Power (11/45) (deleted) Used on equipment with serial numbers up to 1999	70-08784-00					4
	*HARNESSES, Power (11/45) (added) Used on equipment with serial numbers 2000 and above	70-09540-00	00002				4A
32	*Support, Harness	74-09446-00					
33	*Cable, Indicator (Rework)	70-08864-00					
34	*Bracket, Shipping	74-09312-00					
35	*Screw, Phi Pan Hd No. 10 32 x .38	90-06071-01					
36	*Bracket, Cable Holddown	74-10581-00					
37	*Clamp and Strap, Cable	12-11215-00					
38	*Clamp, Cable 7/8 inch	90-07090-00					

FIG & ITEM NO.	DESCRIPTION	DEC PART NO.	ECO	USED ON CODE	VENDOR		REF FIG NO.
			CUT-IN PDP 11/50 00000		CODE	PART NO.	
1-							
39	*Tie Wrap	90-07880-00					
40	*Clamp, Cable 5/8 inch	90-07087-00					
41	*Clamp, Cable 3/16 inch	90-07080-00					
42	*Screw, Phi Pan Hd No. 8 32 x 1 00	90-06043-01					
43	*Key	29-15843-00			99	XX2247	
44	*Molding, Latch	12-09224-00					
45	*Screw, Phi Fit Hd No. 8 32 x 1 4	90-06035-00					
	DECALS (Not Shown)						
	*Decal, Power Supply (Upper P.S.)	53-10049-00					
	*Decal, Power Supply (Lower P.S.)	53-10048-00					
	*Decal, MUL DEC 3 37B-1474 N272 (Top of BA11-F)						
	*Decal, H742 P.S. (A) (deleted)	53-09993-00					
	*Decal, 11/45-11/50 Reg. Config. A (Back of BA11-F) (added)	53-10709-00	00002				
	*Decal, H742 P.S. (B) (deleted)	53-09994-00					
	*Decal, 11/45-11/50 Reg. Config. B (Back of BA11-F) (added)	53-10710-00	00002				
	*Decal, Patent (Back of BA11-F) (added)	74-09478-00	00003				
	*Decal, Back Panel Caution (On exposed panel of BA11-F behind Console) (added)	74-11170-00	00001				

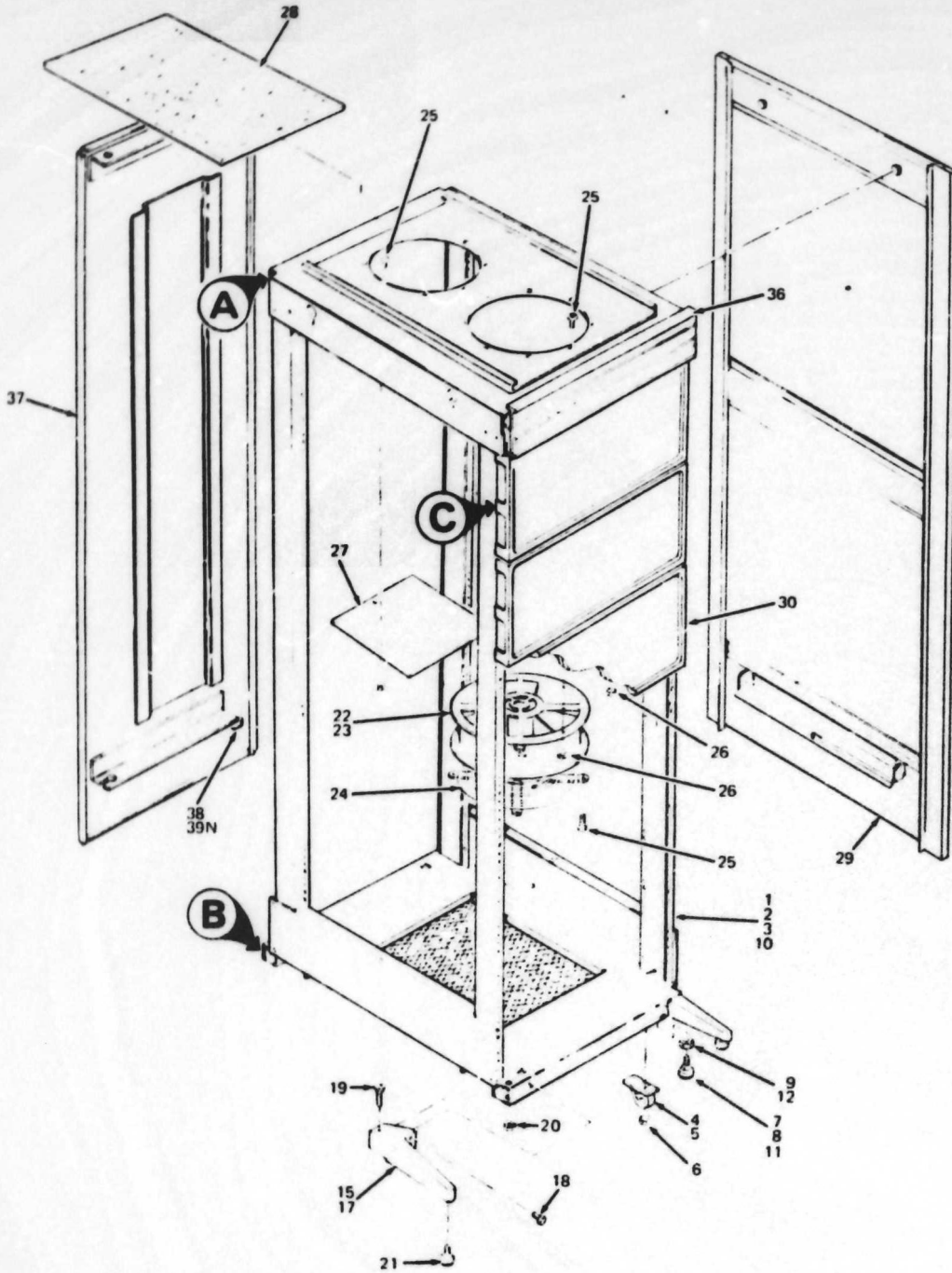

11/45-03

Figure 2. H960C Main Cabinet Assembly (Sheet 1 of 2)



IPB-11/50

PDP 11/50 - 6

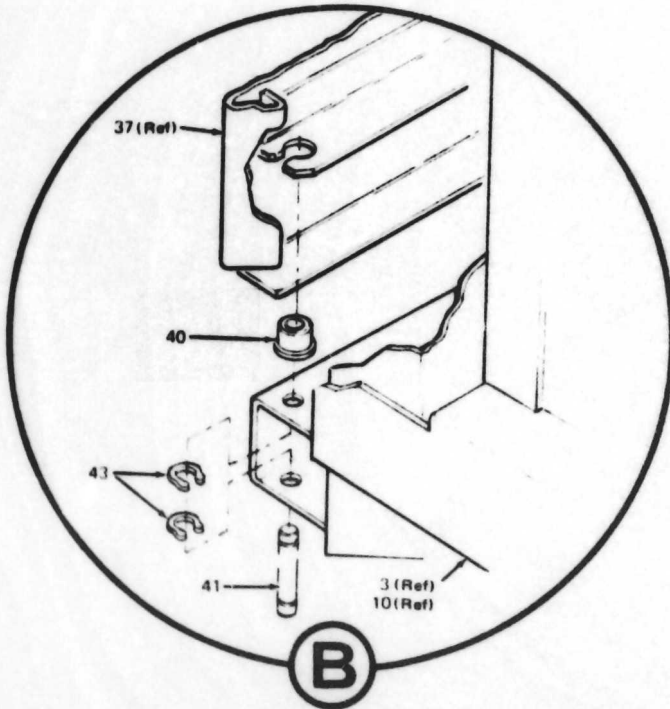
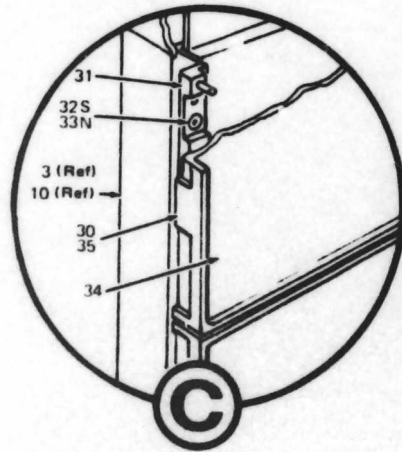
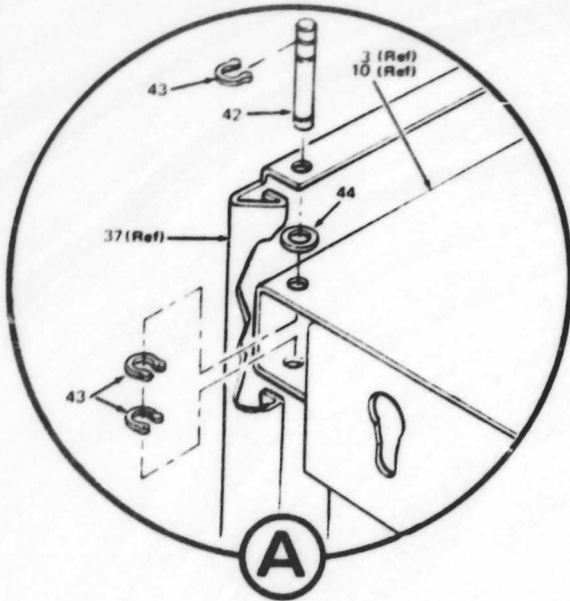

11/45-04

Figure 2. H960C Main Cabinet Assembly (Sheet 2 of 2)

FIG & ITEM NO.	DESCRIPTION	DEC PART NO.	ECO CUT-IN H960C 00000	USED ON CODE	VENDOR		REF FIG NO.
					CODE	PART NO.	
2-	H960C MAIN CABINET ASSEMBLY	H960-CD					1
1	**BASIC CABINET ASSEMBLY, 19 inch	70-06501-27					
2	**CABINET ASSEMBLY (19 inch) with Casters and Levelers (deleted)	70-06478-00					
3	***FRAME ASSEMBLY, 19 inch (deleted)	H950-AA					
4	***Caster Set (deleted) See Note 1.	H952-E					
5	****Caster (deleted)	90-05835-00					
6	****Nut, Kep No. 5/16-18 (deleted)	90-06568-00					
7	***Leveler Set (deleted)	H952-F					
8	****Leveler (deleted)	90-07600-00	H950				
9	****Nut, Hex Lock No. 1/2-13 (deleted)	90-06595-00	00101				
10	**FRAME ASSEMBLY (19 inch) with Casters and Levelers (added) See Note 1.	H950-AA					
11	***Leveler (added)	90-07600-00	H950				
12	***Nut, Hex Lock No. 1/2-13 NC (added)	90-06596-00	00101				
13	***Screen, Bottom Pan (added)		H950A				
14	***Screw, Sems Std Hd No. 10-32 x 5/8 (added)		00001				
15	**STABILIZER FOOT ASSEMBLY	H952-BA	H950				
16	***Foot, Stabilizer (R.H.)	74-06699-01	00102				
17	**Foot, Stabilizer (L.H.)	74-06699-02	H950				
18	***Screw, Phi Truss Hd No. 10-32 x 3/4 (Passivate)	90-07630-00	00102				
19	***Screw, Shoulder Fit Hd No. 1/4-20 x 2 5/8	90-08370-00	H950				
20	**Nut, Kep No. 1/4-20	90-08203-00	00102				
21	***Leveler	90-07601-00	H950				
22	**FAN ASSEMBLY, 115V	H952-CA	A				
23	**FAN ASSEMBLY, 230V	H952-CB	B				
24	***Fan, Caravel, 115V	12-04826-00	A				
25	***Fan, Caravel, 230V	12-09798-00	B				
26	***Guard, Finger	12-09175-00					
27	**Screw, Phi Pan Hd No. 6-32 x 1/2	90-06022-01					
28	**Nut, Kep No. 6-32	90-06560-00					
29	**Cover, Fan Hole	74-06706-00					
30	**Filter	H950-SA					
31	*Panel, End	H952-AA					
32	*Panel, Cover (10 1/2 inch)	H950-QA					
33	**Molding, Thick Latch	12-11386-00					
34	**Screw, Phi Fit Hd No. 10-32 x 1/2	90-06073-02					
35	**Nut, Tinnerman No. 10-32	90-07786-00					
36	**Inlay	12-09176-02					
37	**Bezel, Snap on (10 1/2 inch)	12-09225-00					
38	*Logo, PDP 11	74-07936-04					
39	*Door, Full Length (R.H.)	H950-BA					
40	**Magnet	12-09165-00					
41	**Nut, Kep No. 6-32	90-06560-00					
42	**Bushing, Pivot	74-06702-00					
43	**Pin, Door	74-06672-00					
44	**Pin, Door	74-06671-00					
	**Ring, Retaining	90-07184-00					
	**Washer, Nylon 1/2 OD x 11/32 ID x 1/16	12-09163-00					
	Note 1 On new cabinets, casters are welded to the frame						

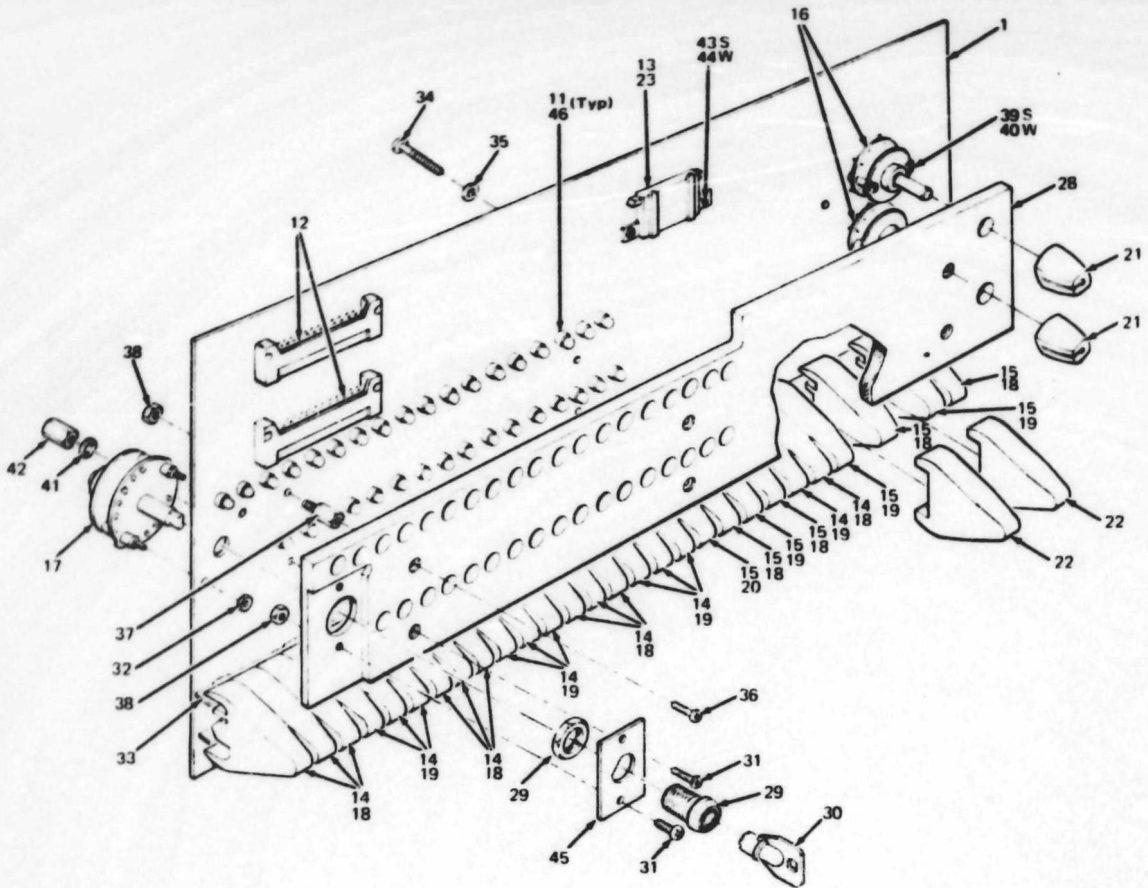

ETCH REV B

11/45-05

Figure 3. Etch Board Assembly (Etch Rev B) (Sheet 1 of 2)

1

11



IPB-11/50

PDP 11/50 - 9

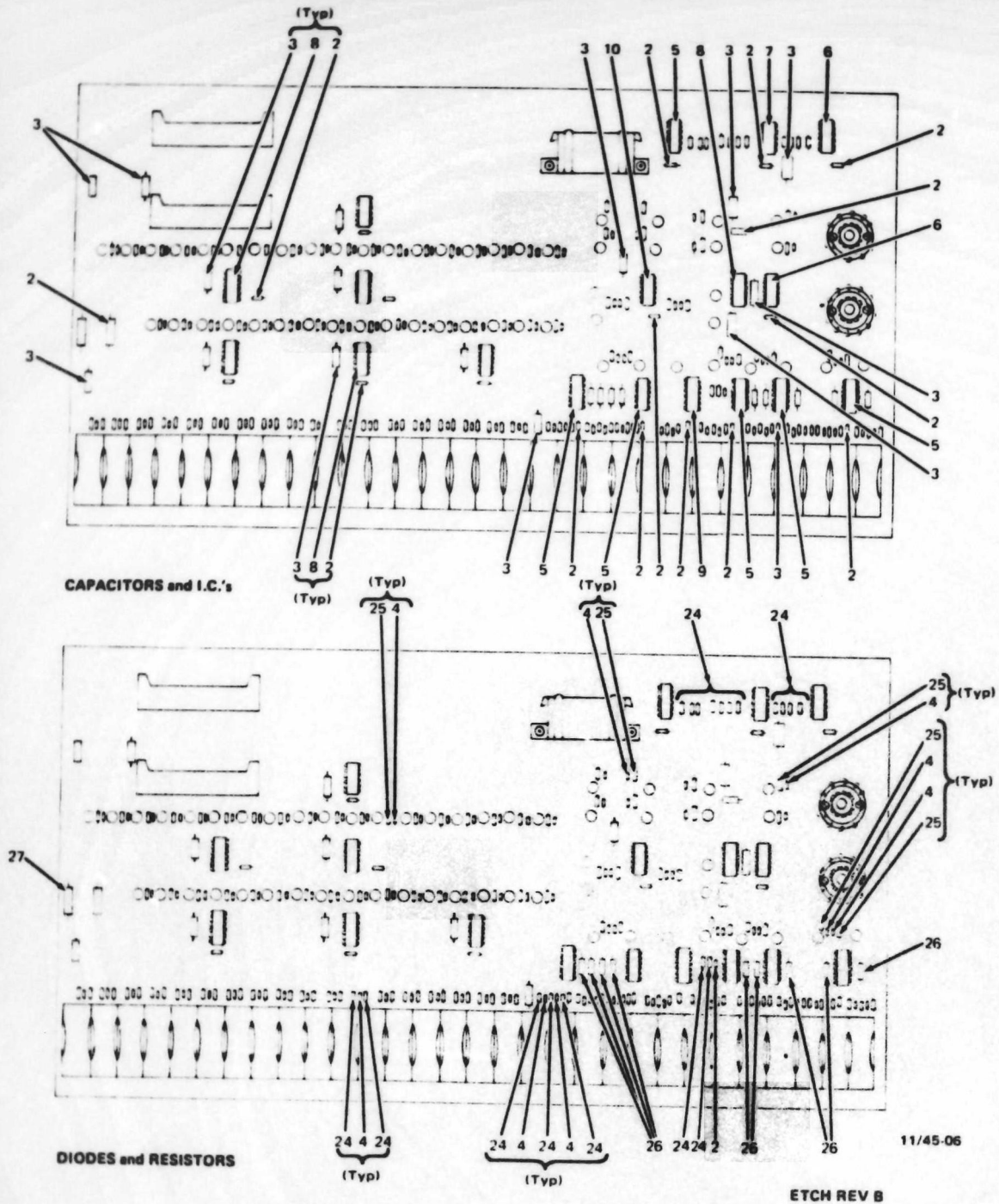
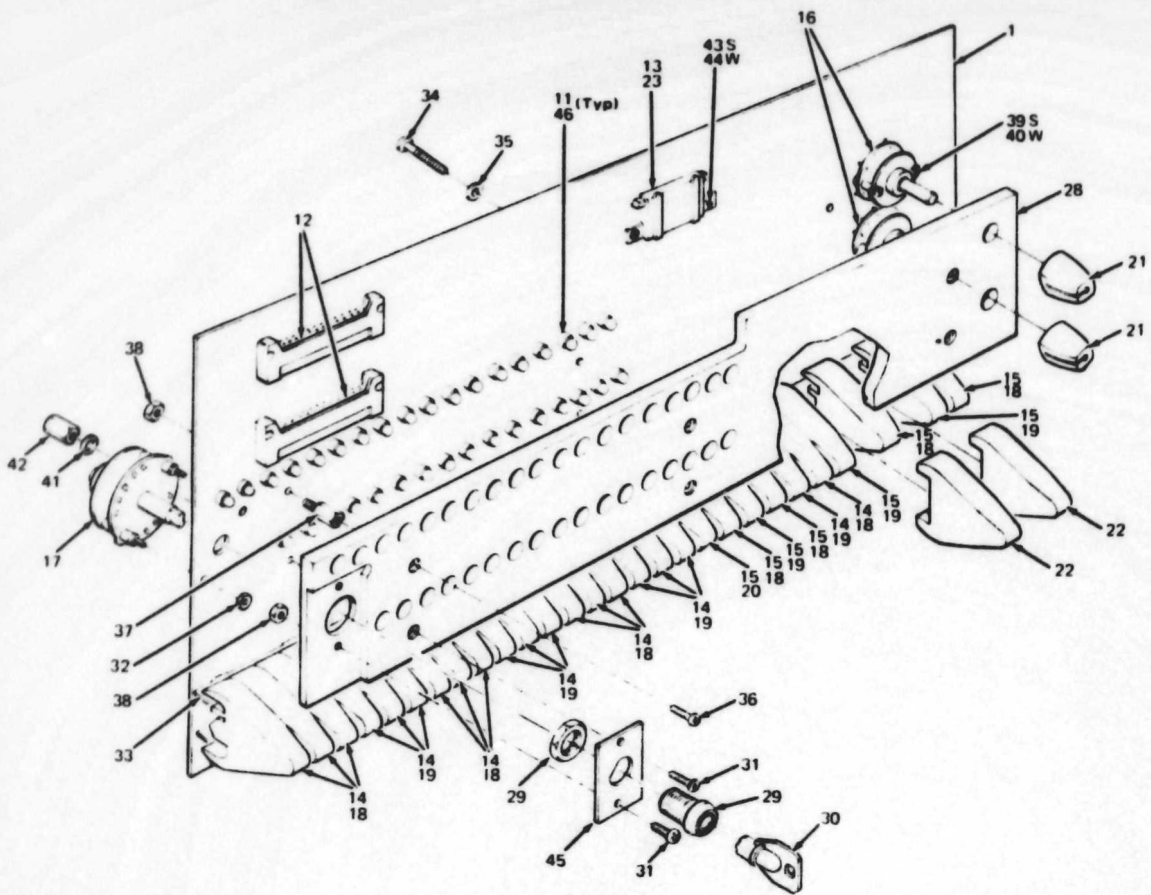

Figure 3. Etch Board Assembly (Etch Rev B) (Sheet 2 of 2)

  
 PARTS LIST

PDP 11/50 - 14

FIG & ITEM NO.	DESCRIPTION	DEC PART NO.	ECO CUT-IN 54-09684 00000	USED ON CODE	VENDOR		REF FIG NO.
					CODE	PART NO.	
3-	ETCH BOARD ASSEMBLY (ETCH REV B)	54-09684-00					1
1	*Board, Etched Circuit	50-09603-00					
2	*Capacitor (C1-C18,C34) .01 MFD 100V 20%	10 01610-00					
3	*Capacitor (C19-C33) 6.8 MFD 35V 20% (C25-C33 added)	10-00067-00	00001				
4	*Diode (D1-D91) D664	11-00114-00	00001				
5	*I.C. (E1,E3,E6,E10-E12) DEC 7400	19-05575-00					
6	*I.C. (E2,E4) DEC 7417	19-09929-00					
7	*I.C. (E5) DEC 9318	19-10454-00					
8	*I.C. (E7,E13-E18) DEC 7416	19-09928-00					
9	*I.C. (E8) DEC 7404	19-09686-00					
10	*I.C. (E9) MC 3001	19-09514-00					
11	*Lamp (I1-I54) 2309 G Hudson Blue	12-09219-00					
12	*Connector (J1,J2) Right Angle Header	12-09941-00					
13	*Connector (J3) (Pin Housing) Mate-N-Lok	12-09340-00					
14	*Switch (S1-S18,S23,S24) Toggle, Momentary	12-10840-00					
15	*Switch (S19-S22,S25-S28) Toggle, Momentary	12-10841 00					
16	*Switch (S29,S31) Rotary, 8 Position	12 10775 00					
17	*Switch (S30) Rotary, 3 Position	12-10753-00					
18	*Knob, Switch (Rose)	12-10796-01					
19	*Knob, Switch (Magenta)	12-10796-02					
20	*Knob, Switch (Gray)	12-10796-03					
21	*Knob, Function (Black)	12-10773-00					
22	*Knob, Dummy (Gray)	12 10825-00					
23	*Pin, Socket AMP No. 61320-1	12-09456-00					
24	*Resistor (R1-R36,R55-R57,R62-R78, R111-R119,R123-R131,R135,R136) 22K Ohm 1/4W 10%	13-00418-00					
25	*Resistor (R37-R54,R58-R61,R82-R109, R137-R140) 220 Ohm, 1/4W 10%	13-00275-00					
26	*Resistor (R79-R81,R120-R122,R132-R134) 100 Ohm 1/4W 10% (deleted)	13-00231 00	00001				
27	*Resistor (R141) 270 Ohm 1/4W 10% (added)	13-00286-00	00001				
28	*Support, Indicator Panel	74-09485-00					
29	*Lock, Power	12-10754-00					
30	*Key, Power Lock	29-15843-00			99	XX2247	
31	*Screw, Phi Pan Hd No. 6-32 x .38	90 06022-01					
32	*Nut, Kep No. 4-40	90-06557-00					
33	*Support, Switch	74-09270-01					
34	*Screw, Phi Pan Hd No. 8-32 x .31 (deleted)	90-06036-01					
	*Screw, Self Tapping No. 8-32 x 1/4 (added)	90-09143-00	00001				
35	*Washer, Lock Int. Tooth No. 8	90-06634 00					
36	*Screw, Phi Pan Hd No. 6-32 x .50	90-06024-01					
37	*Standoff, Male-Female No. 6-32	90-09120-01					
38	*Nut, Kep No. 6-32	90-06560-00					
39	*Washer, Lock Int Tooth No. 2	90-06631-00					
40	*Nut, Hex No. 2-56	90-06555-00					
41	*Washer, Lock Int Tooth No. 6	90-06633-00					
42	*Spacer, No. 6-32 x .88	90-06861 00					
43	*Screw, Phi Pan Hd No. 4-40 x .38	90-06011-01					
44	*Washer, Fiber H.H. Smith No. 2162	90-06693-00					
45	*Strap, Lock Mounting	74-09489-00					
46	*Socket, Lamp	90-07812-00					



ETCH REV C, D and E

11/45-05

Figure 3A. Etch Board Assembly (Etch Rev C,D and E) (Sheet 1 of 2)



15

PARTS LIST

IPB-11/50

PDP11/50-12

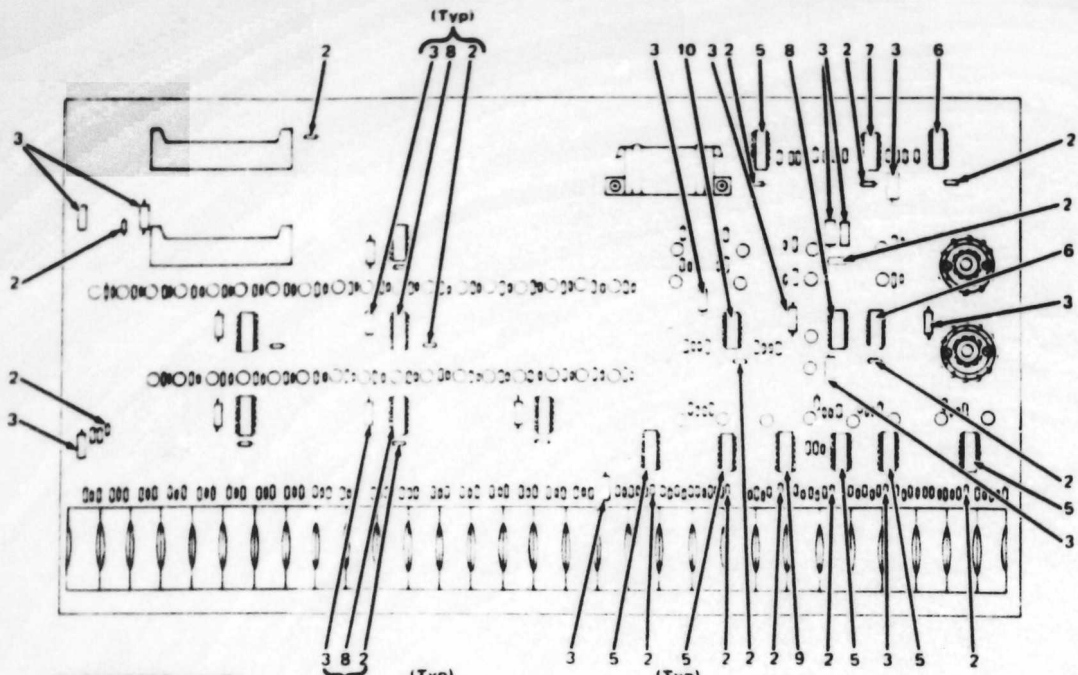

**CAPACITORS and I.C.'s**

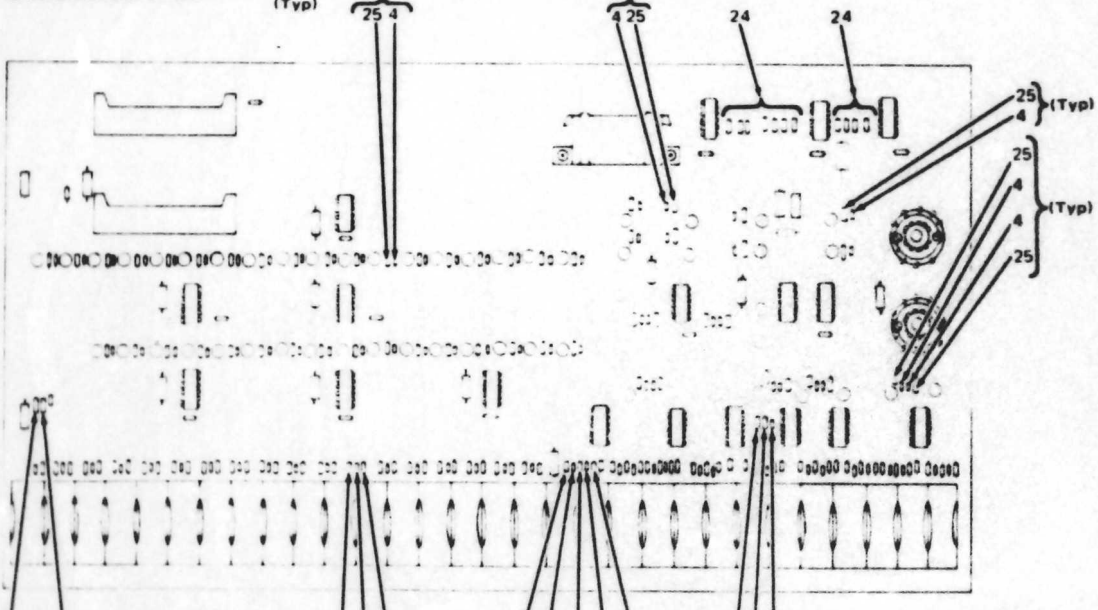

**DIODES and RESISTORS**

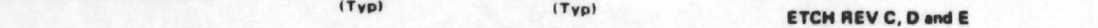

11/45-07

ETCH REV C, D and E

Figure 3A Etch Board Assembly (Etch Rev C,D and E) (Sheet 2 of 2)



PDP 11/50-13

FIG & ITEM NO.	DESCRIPTION	DEC PART NO.	ECO CUT-IN 54-09684 00002	USED ON CODE	VENDOR		REF FIG NO.
					CODE	PART NO.	
3A-	ETCH BOARD ASSEMBLY (ETCH REV C)	54-09684-00					1
	ETCH BOARD ASSEMBLY (ETCH REV D)	54-09684-00	00004				1
	ETCH BOARD ASSEMBLY (ETCH REV E)	54-09684-00	00005				1
1	*Board, Etched Circuit	50-09603-00					
	*Board, Etched Circuit	50-09603-00	00004				
	*Board, Etched Circuit	50-09603-00	00005				
2	*Capacitor (C1-C18, C34-C36) .01 MFD 100V 20%	10-01610-00					
3	*Capacitor (C19-C33) 6.8 MFD 35V 20%	10-00067-00					
4	*Diode (D1-D91) D864	11-00114-00					
5	*I.C. (E1,E3,E6,E10-E12) DEC 7400	19-05575-00					
6	*I.C. (E2,E4) DEC 7417	19-09929-00					
7	*I.C. (E5) DEC 9318	19-10454-00					
8	*I.C. (E7,E13-E18) DEC 7416	19-09928-00					
9	*I.C. (E8) DEC 7404	19-09686-00					
10	*I.C. (E9) MC 3001	19-09514-00					
11	*Lamp (I1-I54) 2309G Hudson Blue	12-09219-00					
12	*Connector (J1,J2) Right Angle Header	12-09941-00					
13	*Connector (J3) (Pin Housing) Mate N-Lok	12-09340-00					
14	*Switch (S1-S18,S23,S24) Toggle, Momentary	12-10840-00					
15	*Switch (S19-S22,S25-S28) Toggle, Momentary	12-10841-00					
16	*Switch (S29,S31) Rotary, 8 Position	12-10775-00					
17	*Switch (S30) Rotary, 3 Position	12-10753-00					
18	*Knob, Switch (Rose)	12-10796-01					
19	*Knob, Switch (Magenta)	12-10796-02					
20	*Knob, Switch (Gray)	12-10796-03					
21	*Knob, Function (Black)	12-10773-00					
22	*Knob, Dummy (Gray)	12-10825-00					
23	*Pin, Socket AMP No. 61320-1	12-09456-00					
24	*Resistor (R1-R36,R55-R57,R62-R78, R111-R119, R123-R131, R135, R136) 22K Ohm 1/4W 10%	13-00418-00					
25	*Resistor (R37-R54,R58-R61,R82-R109, R137-R140) 220 Ohm, 1/4W 10%	13-00275-00					
26	*Resistor (R120) 68 Ohm 1/4W 10%	13-00221-00					
27	*Resistor (R121) 56 Ohm 1/4W 10%	13-01429-00					
28	*Support, Indicator Panel	74-09485-00					
29	*Lock, Power	12-10754-00					
30	*Key, Power Lock	29-15843-00			99	XX 2247	
31	*Screw, Phi Pan Hd. No. 6-32 x .38	90-06022-01					
32	*Nut, Kap No. 4-40 (deleted)	90-06557-00					
	*Nut, Nylon No. 4-40 (added)	90-07992-00	00003				
33	*Support, Switch	74-09270-01					
34	*Screw, Self Tapping No. 8-32 x 1/4	90-08143-00					
35	*Washer, Lock Int Tooth No. 8	90-06634-00					
36	*Screw, Phi Pan Hd No. 6-32 x .50	90-06024-01					
37	*Standoff, Male-Female No. 6-32	90-09120-01					
38	*Nut, Kap No. 6-32	90-06560-00					
39	*Washer, Lock Int Tooth No. 2	90-06631-00					
40	*Nut, Hex No. 2-56	90-06555-00					
41	*Washer, Lock Int Tooth No. 6	90-06633-00					
42	*Spacer No. 6-32 x .88	90-06861-00					
43	*Screw, Phi Pan Hd No. 4-40 x .38	90-06011-01					
44	*Washer, Fiber H.H. Smith No. 2162	90-06693-00					
45	*Strap, Lock Mounting	74-09489-00					
46	*Socket Lamp	90-07812-00					

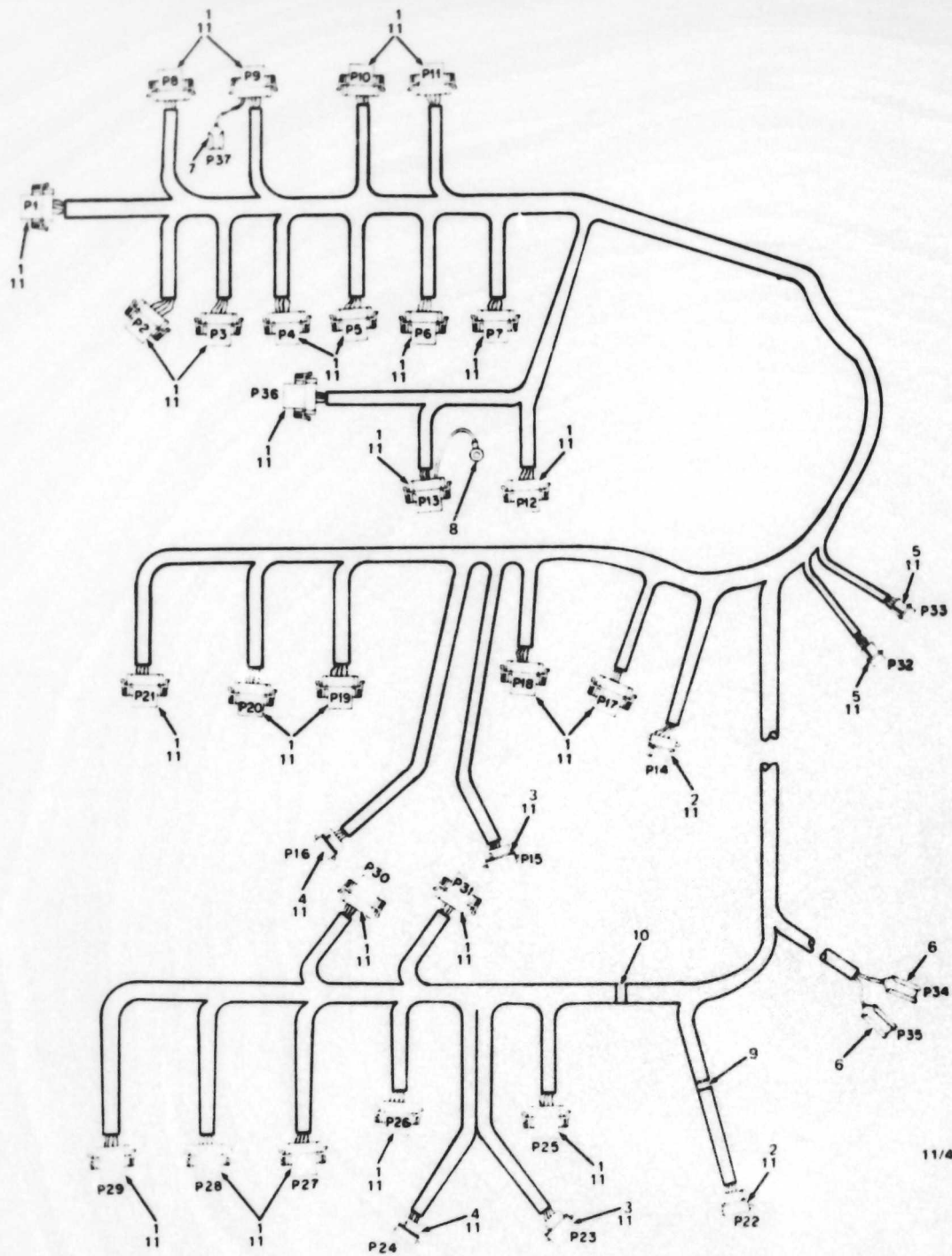

11/45-08

USED ON EQUIPMENT SERIAL NO. 1999 AND BELOW

Figure 4. Power Harness Assembly (11/45)

PDP 11/50-15



FIG & ITEM NO.	DESCRIPTION	DEC PART NO.	ECO CUT-IN 70 08784 00000	USED ON CODE	VENDOR		REF FIG NO.
					CODE	PART NO.	
4-	POWER HARNESS ASSEMBLY (11/45)	70-08784-00					1
1	*Connector (P1-P13, P17-P21, P25-P31, P36) (Pin Housing) Mate-N-Lok (P36 added)	12-09340-01	00001				
2	*Connector (P14, P22)(Pin Housing) Mate-N-Lok	12-09351-12					
3	*Connector (P15, P23)(Pin Housing) Mate-N-Lok (added)	12-09351-15	11-45-00041				
4	*Connector (P16, P24)(Pin Housing) Mate-N-Lok	12-09351-09					
5	*Connector (P32, P33)(Pin Housing) Mate-N-Lok	12-09351-03					
6	*Connector (P34, P35) Arkless No. 50325 (added)	90-07927-00					
7	*Connector (P37) Arkless (added)	90-07928-00	11-45-00022				
8	*Connector, Arkless (added)	90-07928-01	11-45-00051				
9	*Tie Wrap, Panduit SST 1.5M	90-07880-00					
10	*Tie Wrap, Panduit SST2 M	90-070J2-00					
11	*Terminal, Pin Contact	12-09378-01					

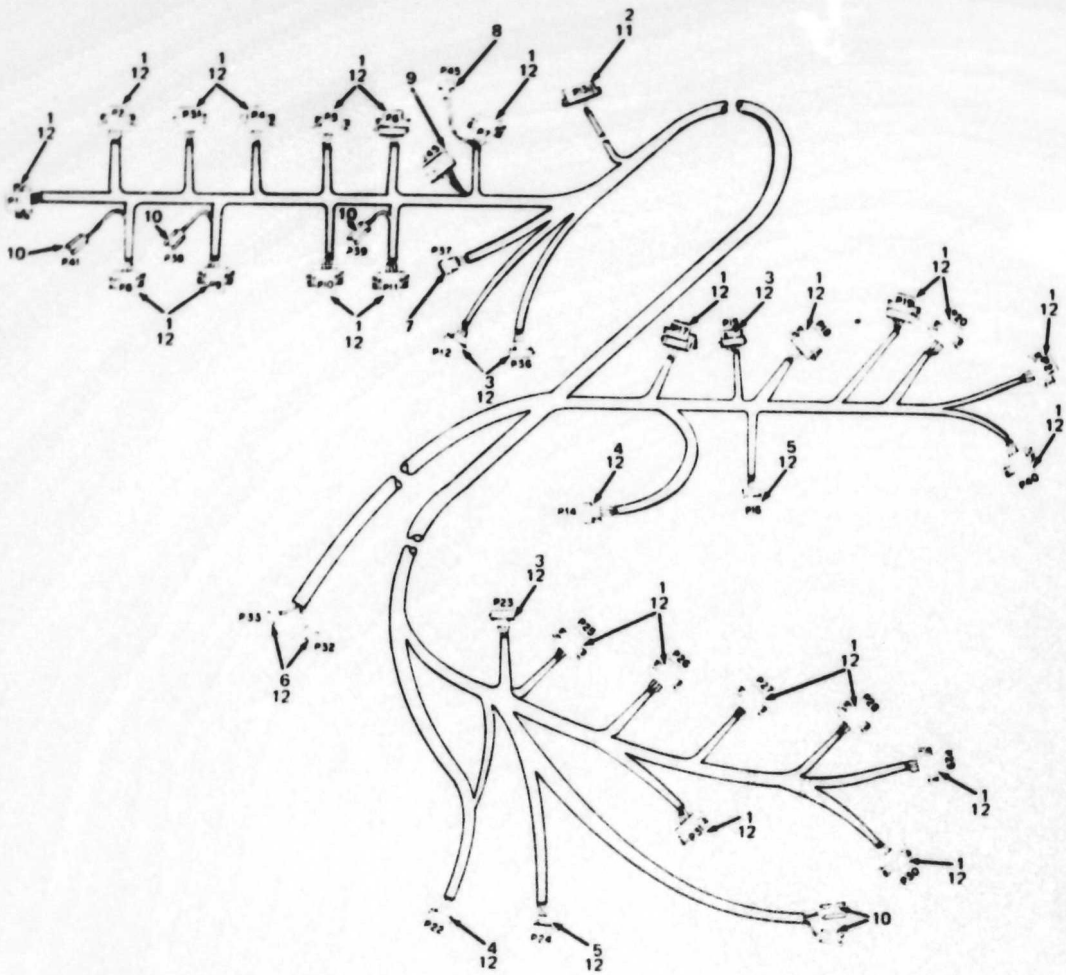

11/45 09

USED ON EQUIPMENT SERIAL NO. 2000 AND ABOVE

Figure 4A. Power Harness Assembly (11/45)

21



IPB-11/50

PDP 11/50 -17

FIG & ITEM NO.	DESCRIPTION	DEC PART NO.	ECO CUT-IN 70 09540 00000	USED ON CODE	VENDOR		REF FIG NO.
					CODE	PART NO.	
4A -	POWER HARNESS ASSEMBLY (11/45)	70 09540 00					1
1	*Connector (P1 P11, P17 P21, P25 P31, P40) (Pin Housing) Mate N Lok	12 09340 01					
2	*Connector (P13) (Socket Housing) Mate N Lok	12 09340 00					
3	*Connector (P12, P15, P23, P26) (Pin Housing) Mate N Lok	12 09351 15					
4	*Connector (P14, P22) (Pin Housing) Mate N Lok	12 09351 12					
5	*Connector (P16, P24) (Pin Housing) Mate N Lok	12 09351 09					
6	*Connector (P32, P33) (Pin Housing) Mate N Lok	12 09351 03					
7	*Connector (P37) (Pin Housing) Mate N Lok	12 09351 06					
8	*Connector (P45) (Pin Housing) Mate N Lok	12 09351 04					
9	*Connector (J45) (Socket Housing) Mate N Lok	12 09350 04					
10	*Connector, Solderless	90 07928 00					
11	*Terminal, Socket Contact	12 09379 00					
12	*Terminal, Pin Contact	12 09378 00					
13	*Tie Wrap	90 07032 00					

DEC