

For: L_HOLMES

Printed on: Mon, Feb 8, 1993 15:38:33

From book: turbo_cov

Document: turbo_cov_new

Last saved on: Thu, Feb 4, 1993 11:07:18

Document: classa_hardware

Last saved on: Thu, Feb 4, 1993 11:06:19

Document: title

Last saved on: Thu, Feb 4, 1993 11:07:08

Document: copyright

Last saved on: Thu, Feb 4, 1993 11:06:30

Document: toc

Last saved on: Thu, Feb 4, 1993 11:22:08

Document: safety

Last saved on: Thu, Feb 4, 1993 11:07:02

Document: preface

Last saved on: Thu, Feb 4, 1993 11:06:49

Document: ch1

Last saved on: Thu, Feb 4, 1993 11:20:40

Document: ch2

Last saved on: Thu, Feb 4, 1993 11:05:51

Document: ch3_1_28_93

Last saved on: Thu, Feb 4, 1993 11:06:02

Document: ch4

Last saved on: Thu, Feb 4, 1993 11:06:08

(...)

DEC FDDIcontroller/TURBOchannel



Installation



Order Number: EK-DEFTA-IN. A01

NOTICE – Class A Laser Device:

The lasers in this equipment are Class 1 devices, compliant with CDRH Rules 21, CFR Subchapter J, Part 1040.10, at date of manufacture. Class 1 laser devices are not considered to be hazardous.

NOTICE – Class A Computing Device:

This equipment generates, uses, and may emit radio frequency energy. The equipment has been type tested and found to comply with the limits for a Class A computing device pursuant to Subpart J of Part 15 of FCC Rules, which are designed to provide reasonable protection against such radio frequency interference when operated in a commercial environment. Operation of this equipment in a residential area may cause interference; in which case, measures taken to correct the interference are at the user's expense.

CAUTION

This equipment is in the 1st Class category (information equipment to be used in commercial and/or industrial areas) and conforms to the standards set by the Voluntary Control Council for Interference by Data Processing Equipment and Electronic Office Machines aimed at preventing radio interference in commercial and/or industrial areas. Consequently, when used in a residential area or in an adjacent area thereto, radio interference may be caused in radios and TV receivers, etc. Read the instructions for correct handling.

DEC FDDIcontroller/TURBOchannel

Installation

February 1993

This manual describes how to install and verify the operation of the DEC FDDIcontroller/TURBOchannel.

Supersession/Update Information: This is a new manual.



Order Number: EK-DEFTA-IN. A01

The information in this document is subject to change without notice and should not be construed as a commitment by Digital Equipment Corporation. Digital Equipment Corporation assumes no responsibility for any errors that may appear in this document.

Copyright © 1993 by Digital Equipment Corporation
All Rights Reserved.
Printed in U.S.A.

The following are trademarks of Digital Equipment Corporation:

Alpha AXP	DECUS	TURBOchannel
DEC	DELNI	VAX
DECconcentrator	DESTA	VMS
DECconnect		
DECnet	ThinWire	

ST is a trademark of American Telephone and Telegraph Co.

IBM is a registered trademark of International Business Machines Incorporated.

This manual was produced by Telecommunications and Networks Publications.

Contents

Safety

Preface

1 Unpacking the Controller

1.1	Overview	1-1
1.2	Physical Description	1-2
1.3	Unpacking and Checking the Contents	1-3

2 Installing the Controller

2.1	Preparing the Computer for Installation	2-1
2.2	Installing the Controller	2-2
2.3	Connecting the FDDI Communications Cable	2-4

3 Verifying and Testing the Controller

3.1	Performing Self-Test	3-1
3.2	Verifying the System Configuration	3-2
3.2.1	Verifying a Configuration Based on an Alpha AXP System	3-2
3.2.1.1	Correcting a Configuration Display Problem	3-2

3.2.2	Verifying and Testing a Configuration Based on a VAX System	3-3
3.3	Booting the System	3-4

4 Troubleshooting the Controller

4.1	Basic Troubleshooting	4-1
4.1.1	Error Messages	4-2
4.1.2	Solving Hardware Problems	4-3

A Related Documents

Figures

1-1	Connecting the Controller to the FDDI Network	1-2
1-2	Components on the Controller	1-2
1-3	Contents of Shipping Package	1-3
2-1	Example of Removing the Option Slot Cover	2-2
2-2	Example of Installing the Controller	2-3
2-3	Example of Connecting the ST-type Connectors	2-5

Tables

4-1	Controller LED Displays (After System Boot)	4-1
-----	---	-----

Safety

Any warning or caution that appears in this manual is defined as follows:

Warning	Contains information to prevent personal injury.
Caution	Contains information to prevent damage to equipment.
Vorsicht	Enthält Informationen, die beachtet werden müssen, um den Benutzer vor Schaden zu bewahren.
Achtung	Enthält Informationen, die beachtet werden müssen, um die Geräte vor Schaden zu bewahren.
Danger	Signale les informations destinées à prévenir les accidents corporels.
Attention	Signale les informations destinées à prévenir la détérioration du matériel.
Aviso	Contiene información para evitar daños personales.
Precaución	Contiene información para evitar daños al equipo.

The cautions you must observe for the hardware described in this manual appear below in English, German, French, and Spanish, along with the pages on which these safety messages appear.

CAUTION 

Static electricity can damage modules and electronic components. Digital recommends using a grounded antistatic wrist strap and a grounded work surface when handling any modules. [Page 1-3, 2-2, 4-3]

ACHTUNG

Module und elektronische Komponenten können durch elektrostatische Entladungen beschädigt werden. Benutzen Sie immer eine antistatische Gelenkmanschette und eine geerdete Arbeitsunterlage, wenn Sie am offenen Gerät arbeiten.

ATTENTION

Les charges excessives d'électricité statique peuvent endommager les modules et les composants électroniques. Digital conseille l'utilisation d'un bracelet de masse et d'un plan de travail mis à la terre lors de la manipulation des modules.

PRECAUCIÓN

La electricidad estática puede dañar los componentes electrónicos y los módulos. Digital recomienda que se utilicen cintas de pasadores y superficies de trabajo conectadas a tierra al trabajar con cualquier módulo.

WARNING 

Some fiber optic equipment can emit laser light that can injure your eyes. Never look into an optical fiber or connector port. Always assume the cable is connected to a light source.
[Page 2–4]

VORSICHT

Schauen Sie niemals direkt in ein Glasfaserkabel oder einen Glasfaseranschluß. Die Laserstrahlen in faser-optischen Geräten können Augenverletzungen verursachen.

DANGER

Certains équipements utilisant les fibres optiques peuvent émettre des rayonne-ment laser dangereux pour les yeux. Ne vous avisez jamais de regarder par l'extrémité d'une fibre optique ou dans l'ouverture d'un connecteur. Considérez toujours que le câble est relié à une source lumineuse.

AVISO

Algunos equipos de fibra óptica pueden emitir luz láser que daña los ojos. No sedebe mirar en una puerta de conector o fibra óptica. Siempre se debe suponer que el cable está conectado a la luz.

Preface

This manual explains how to install the DEC FDDIcontroller/TURBOchannel controller into a TURBOchannel-based platform and how to verify its installation and operation.

Intended Audience

This manual is for the user who has some technical background installing system hardware.

Structure of This Manual

This manual has four chapters and an appendix, as follows:

- Chapter 1** Provides an overview and description of the DEC FDDIcontroller/TURBOchannel controller.
- Chapter 2** Contains installation procedures.
- Chapter 3** Contains controller verification procedures.
- Chapter 4** Contains troubleshooting procedures.
- Appendix A** Lists related documents.

Conventions Used in This Manual

This manual uses the following conventions:

<code>special type</code>	Indicates a literal example of system output.
bold	Indicates a command format that you enter.
lowercase	When a command appears in lowercase, type in a command format. In an example, enter the characters in lowercase.
<code>Key</code>	Indicates that you press the specified key. For example, <code>Return</code> means that you press the Return key.
<code>Ctrl/x</code>	Indicates that you hold down the CONTROL key and simultaneously press the key specified by <i>x</i> .

The postage-paid Reader's Comments form on the last page of this document requests your evaluation of this document to assist us in preparing future documentation.

Unpacking the Controller

This chapter describes the DEC FDDIcontroller/TURBOchannel controller for TURBOchannel-based computers. The controller is an option that provides a direct connection between a TURBOchannel slot and the Fiber Distributed Data Interface (FDDI) network. From this point on in the manual, the DEC FDDIcontroller/TURBOchannel controller is called the DEC FDDIcontroller/TURBOchannel or controller.

1.1 Overview

The DEC FDDIcontroller/TURBOchannel is a single attachment station (SAS) that connects through a fiber optic cable to any FDDI-compliant concentrator (such as the DECconcentrator 500).

Figure 1-1 shows how a TURBOchannel-based computer connects to the FDDI network through the DEC FDDIcontroller/TURBOchannel and the concentrator.

Figure 1-1: Connecting the Controller to the FDDI Network

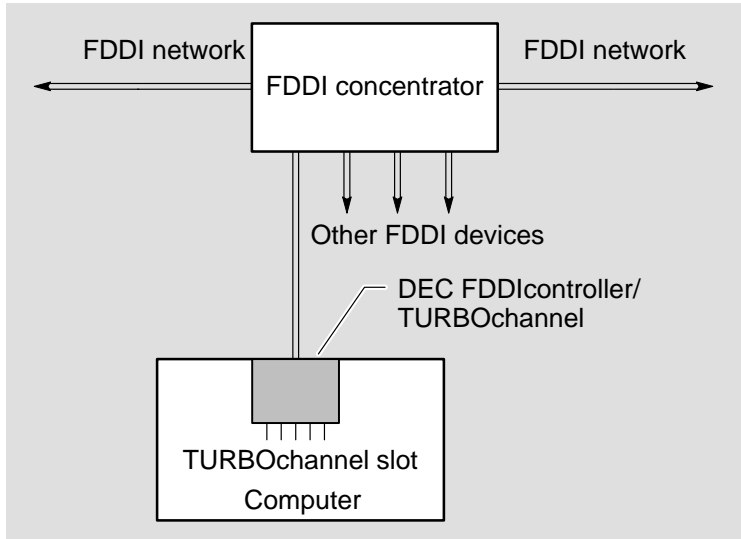

LKG-6237-921

1.2 Physical Description

The controller consists of one circuit card. A 96-pin connector on the card plugs into the computer's TURBOchannel slot. ST-type connectors are the interface to FDDI optical fiber. Figure 1-2 shows the components on the controller.

Figure 1-2: Components on the Controller

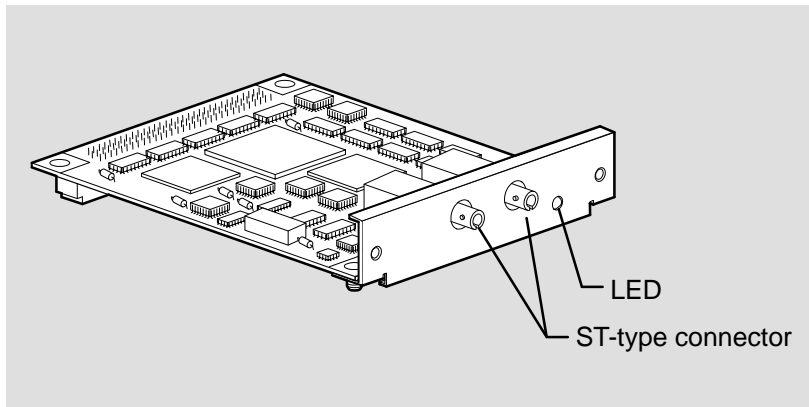

LKG-7346-921

1.3 Unpacking and Checking the Contents

CAUTION

Static electricity can damage modules and electronic components. Digital recommends using a grounded antistatic wrist strap and a grounded work surface when handling any modules.

The controller is shipped in one box (see Figure 1–3 for contents). Remove the contents from the box and place them nearby until you are ready to install the controller.

Check the shipment for damage and missing parts. In case of damage, contact your delivery agent and your Digital sales representative. If parts are missing, contact your Digital sales representative.

Figure 1–3: Contents of Shipping Package

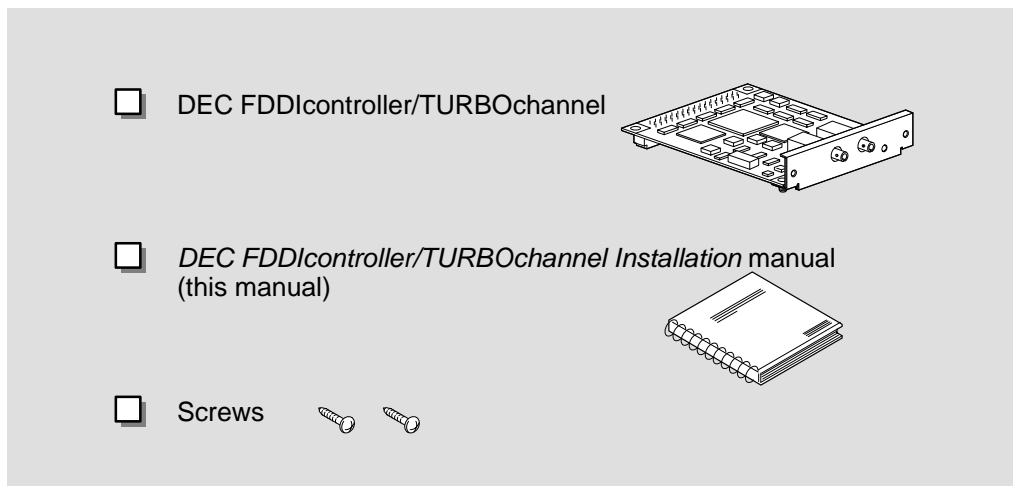

LKG-7347-921

Installing the Controller

This chapter explains how to unpack and install the DEC FDDIcontroller/TURBOchannel. Installing your controller includes:

1. Preparing the computer for installation
2. Installing the controller
3. Connecting the FDDI communications cable

2.1 Preparing the Computer for Installation

To prepare the computer for installation, you need a Phillips-head screwdriver and antistatic wrist strap kit. Perform the following steps:

1. Turn off the computer.
2. Remove the cover from the computer unit. Refer to your computer documentation for instructions on how to do this.
3. Refer to your computer documentation to determine which slot(s) you can use.

NOTE

Some systems are not equipped for the DEC FDDIcontroller/TURBOchannel network controller. You may need to install a TURBOchannel system adapter into your system before installing the controller. Refer to your system documentation for specific requirements.

4. Remove the option slot cover from one of the TURBOchannel option slots (see Figure 2-1). Use a Phillips-head screwdriver to remove the two screws that hold the slot cover in place. Save the option slot cover and screws.

Figure 2-1: Example of Removing the Option Slot Cover

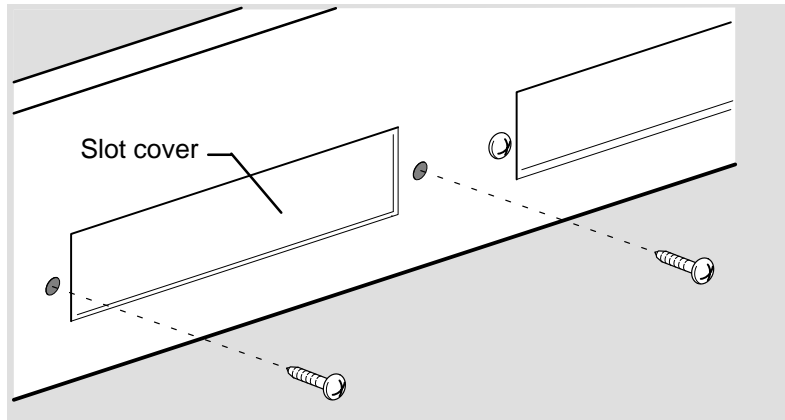

2.2 Installing the Controller

Install the controller into the computer as follows:

CAUTION

Static electricity can damage modules and electronic components. Digital recommends using a grounded antistatic wrist strap and a grounded work surface when handling any modules.

1. Attach one end of the antistatic wrist strap to your wrist and the other end to the computer.
2. Hold the controller by the edges and position it so that it is parallel with the bottom of the computer (see Figure 2-2), its TURBOchannel 96-pin connector is facing down, and its ST-type connectors are facing the option-slot opening in the back of the computer.
3. Insert the controller ST-type connectors through the option-slot opening in the back of the computer unit.

4. Firmly push the TURBOchannel 96-pin connector into the TURBOchannel connector on the computer unit circuit card.
5. Fasten the controller to the computer's circuit card (near the 96-pin connector) with the two screws supplied in the controller shipping package.

NOTE

If your unit has two nylon clips on the 96-pin connector, push the controller onto the nylon pins and make sure the clips snap in place. You do not need to use screws.

6. Insert the two screws, which held the metal slot cover on, into the back of the computer to hold the controller in place (see Figure 2-2).
7. Remove the antistatic wrist strap from your wrist and from the computer. Close the computer.

Figure 2-2: Example of Installing the Controller

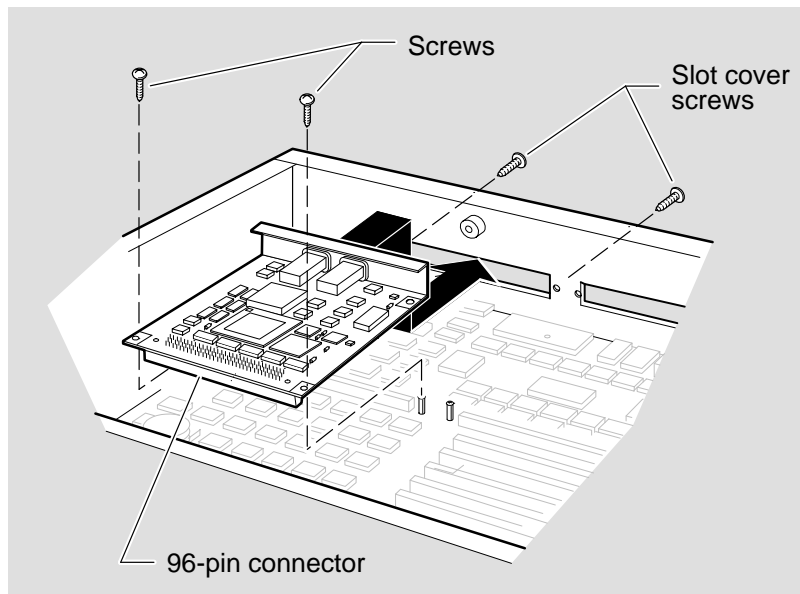

LKG-7349-921

2.3 Connecting the FDDI Communications Cable

The controller has two ST-type FDDI connectors. To attach the FDDI cables, perform the following:

NOTE

Make sure that the bend radius of any fiber optic cable is 2.5 cm (1 in) or greater. To avoid optical power loss, do not touch the fiber ends.

1. Remove the dust caps from the ST-type connectors.

WARNING

Some fiber optic equipment can emit laser light that can injure your eyes. Never look into an optical fiber or connector port. Always assume the cable is connected to a light source.



2. Line up the transmit cable connector with the transmit port (). Insert and turn the connector clockwise to lock it into place.
3. Line up the receive cable connector with the receive port (). Insert and turn the connector clockwise to lock it into place.

Figure 2-3: Example of Connecting the ST-type Connectors



LKG-7350-921

Verifying and Testing the Controller

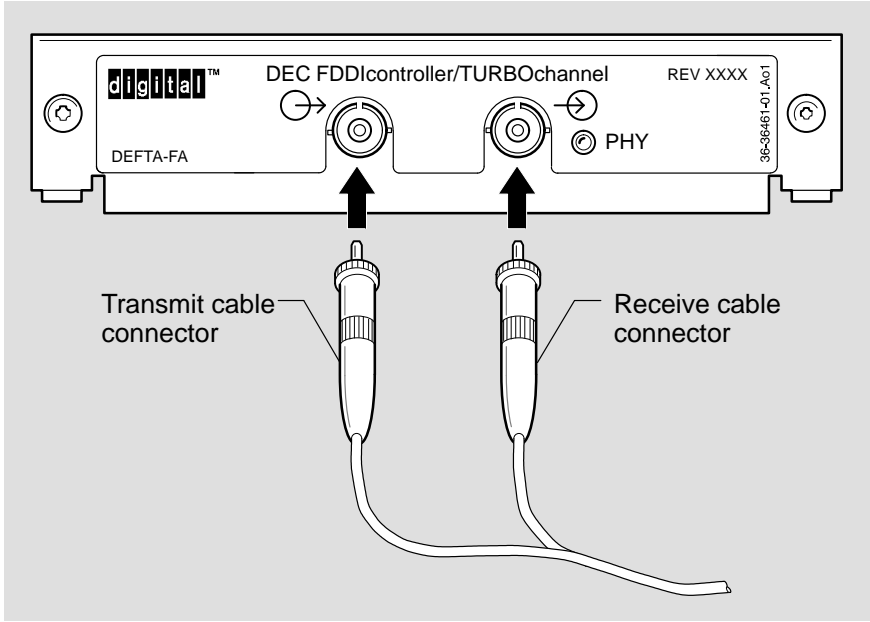
Once you install the controller, verify that it works and that you have a communication link. Verifying your controller operation involves the following:

1. Performing self-test
2. Verifying the system configuration
3. Booting your system and verifying the FDDI communications connection

3.1 Performing Self-Test

Turning on the power for Alpha AXP and MIPs systems starts the controller self-test. When self-test completes, the PHY LED on the controller will be OFF, indicating the controller is working properly. If the PHY LED is ON (RED), contact your Digital Services representative. For information about system self-test, refer to your system documentation.

NOTE

The VAX system does not test the controller when it is turned on. For information on testing the controller based on a VAX system, go to Section 3.2.2.

3.2 Verifying the System Configuration

Once the computer successfully completes self-test, verify that your system configuration recognizes the controller by performing one of the following procedures:

- If your machine is based on an Alpha AXP system, go to Section 3.2.1.
- If your machine is based on a VAX system, go to Section 3.2.2.

3.2.1 Verifying a Configuration Based on an Alpha AXP System

Display your controller information by typing **t tcn cnfg** (*n* representing the slot number for the controller) at the system prompt and press **Return**. The following is an example of the configuration display that appears on the screen:

```
>>> t tc0 cnfg Return
DEC PMAF - FA V5.3a (fddi :08-00-2b-a0-1f-04)
>>>
```

If the controller is listed, go to Section 3.3. If the controller does not appear in the configuration display, refer to Section 3.2.1.1 for problem-solving information.

3.2.1.1 Correcting a Configuration Display Problem

If your controller does not appear in the display, perform the following:

1. Verify that the PHY LED on the controller is ON (RED). This indicates that the controller failed self-test. The failure may be due to improper installation. For information on solving hardware problems, refer to Section 4.1.2.
2. Turn the computer power off.
3. Check the connections on the controller and the computer.
4. Perform the self-test and system configuration procedures (see Section 3.1 and Section 3.2). If the problem persists, contact your Digital Services representative. Otherwise, go to Section 3.3.

3.2.2 Verifying and Testing a Configuration Based on a VAX System

To verify and test configuration based on a VAX system perform the following steps:

1. Change the system prompt to the test utility prompt. Enter **test/util tca** at the system prompt and press **Return**. The system displays the following message and the test utility prompt (>>):

```
>>> test/util tca Return
.....TURBOCHANNEL REX EMULATOR.....
>>
```

2. Verify the configuration. Enter **t tc0 cnfg** at the test utility prompt and press **Return**. The system displays a message similar to the following example:

```
>> t tc0 cnfg Return
      DEC PMAF-F V5.3a (fddi: 08-00-2b-20-a2-03)
>>
```

3. Test the configuration by entering **t tc0 pst-q** at the utility prompt and pressing **Return**. The system displays the following tests:

```
>> t tc0 pst-q
#E mul: t tc0 pst-q
      t#/ boot_crc
      t#/ main_crc
      t#/ core_ram
      t#/ pdq
      t#/ pkt_mem
      t#/ mac
      ?TFL: # elm test failed [PMAF-FA]*
      t#/ cam
      t#/ ieeerom
      t#/ intlpbk
      t#/ extlpbk
      t#/ dmatst
      t#/ extmemtest
>>
```

* In this example, **?TFL: # elm test failed [PMAF-FA]** is an error message and indicates the elm test has failed. For information on error messages, go to Section 4.1.1.

When you successfully complete the system tests, enter **Ctrl/D** to return to the system prompt.

3.3 Booting the System

Once you verify the configuration, boot the operating system. Refer to your operating system documentation for instructions on how to perform this. After booting, verify that the controller PHY LED is on (STEADY GREEN), indicating a LINK AVAILABLE state if connected to network. If the LED is not steady green, refer to Chapter 4 for information on troubleshooting.

The controller is working properly and the installation is now complete.

Troubleshooting the Controller

This chapter explains how to troubleshoot the controller using the LED indicators. It also describes the controller LED displays and error messages.

4.1 Basic Troubleshooting

If the controller fails self-test, the PHY LED on the controller turns ON (RED) and error messages appear on the console screen. Table 4–1 describes LED displays for problems and possible corrective actions. Section 4.1.1. contains a list of error messages.

Table 4–1: Controller LED Displays (After System Boot)

LED Display	Probable Cause	Corrective Action
LED OFF	Controller not enabled.	Check the console for error messages. Refer to the list of error messages in Section 4.1.1.
	LED or controller broken.	Contact your Digital Services representative.
LED steady red	Unsupported configuration or ring topology.	Notify your system manager. Reconfigure the cable connections or ring topology.
LED blinking red	Unsupported configuration or ring topology.	Notify your system manager. Reconfigure the cable connections or ring topology.
	Link Confidence Test failure.	Check cable connections.
LED blinking green	Unable to connect. No cable attached.	Check cable connections. Interchange cable connections.
	Operational fault detected.	Check system error log.
LED steady green	Controller enabled. Physical connection established.	None.

4.1.1 Error Messages

In addition to the LED indicating a controller failure, one or more of the following error messages may appear on the system console display:

```
t#/ boot_crc
?TFL: # main_crc test failed [PMAF-FA]
?TFL: # core_ram test failed [PMAF-FA]
?TFL: # pdq test failed [PMAF-FA]
?TFL: # pkt_mem test failed [PMAF-FA]
?TFL: # mac test failed [PMAF-FA]
?TFL: # elm test failed [PMAF-FA]
?TFL: # cam test failed [PMAF-FA]
?TFL: # ieeerom test failed [PMAF-FA]
?TFL: # intlpbk test failed [PMAF-FA]
?TFL: # extlpbk test failed [PMAF-FA]
?TFL: # dmatst test failed [PMAF-FA]
?TFL: # extmentest test failed [PMAF-FA]
```

The following list explains the components in an error message:

- `t#/` is not an error message. This indicates that the test passed.
- The question mark at the beginning of the line indicates that this is an error message.
- The three letters that follow the question mark indicate that a test has failed.

If any letters other than TFL appear in this location, call your system manager or your Digital Services representative.

- A number appearing in place of the # character indicates the slot location of the controller.
- The remainder of the message indicates the test that failed and the controller part number.

4.1.2 Solving Hardware Problems

CAUTION

Static electricity can damage modules and electronic components. Digital recommends using a grounded antistatic wrist strap and a grounded work surface when handling any modules.

The following list provides possible solutions to several hardware problems:

- Be sure that the controller is inserted tightly in its slot and that anything connected to it is connected correctly.
- If you have another controller that works, try it in that slot. If the test no longer fails, the problem is in the controller. If the test continues to fail, the problem is in the system.
- If you do not have another controller that works, move the controller to another slot. If the test no longer fails, the problem is in the system. If the test continues to fail, the problem is in either the controller or the system.

If the problem persists after trying these suggestions, contact your Digital Services representative.

Related Documents

For additional information about the installation and testing of the DEC FDDIcontroller/TURBOchannel, refer to the following documents:

- Your workstation or system documentation kit
- *DECconcentrator 500 Installation*
(Order No. EK-DEFCN-IN)
Describes how to configure and install the DECconcentrator 500.
- *Fiber Distributed Data Interface System Level Description*
(Order No. EK-DFSLD-SD)
Describes the FDDI system, how it works, and the role of the individual components.
- *Fiber Distributed Data Interface Network Configuration Guidelines*
(Order No. EK-DFDDI-CG)
Describes the guidelines for connecting devices to an FDDI network. It also includes network configuration examples.
- *A Primer on FDDI: Fiber Distributed Data Interface*
(Order No. EC-H1580-42/92 07), Version 2.0
Describes the features, topologies, and components of the FDDI local area network (LAN) standard.

Index

B

Booting the System, 3–4

C

Cable, connecting the communications,
2–4

Cable connector

receive, 2–4

transmit, 2–4

Components, 1–2

Configuration display, 3–2

correcting problems, 3–2

D

DECconcentrator 500, 1–1

Diagnostics, 4–1

E

Error messages, 4–1, 4–2

F

FDDI, 1–1

FDDI network, connection to, 1–2

FDDI-compliant concentrator, 1–1

H

Hardware problems, 4–3

I

Installing the Controller, 2–1

L

LED display, 4–1

LINK AVAILABLE state, 3–4

P

PHY LED, 4–1

Physical description, 1–2

Preparing the System, 2–1

R

Related documents, A–1

S

SAS, 1-1
Self-test, performing, 3-1
Shipping package, contents, 1-3
Single attachment station, 1-1
Slot cover, 2-2
Static electricity, 1-3, 2-2

T

Test display, 4-1

Troubleshooting, 4-1
 basic, 4-1

V

Verifying system configuration, 3-2
 based on Alpha AXP, 3-2
 based on VAX, 3-3

HOW TO ORDER ADDITIONAL DOCUMENTATION

DIRECT TELEPHONE ORDERS

In Continental USA
call 1-800-DIGITAL
(1-800-344-4825)

In Canada
call 800-267-6215

In New Hampshire,
Alaska or Hawaii
call 603-884-6660

ELECTRONIC ORDERS (U.S. ONLY)

Dial 800-dec-demo with any VT100 or VT200
compatible terminal and a 1200 baud modem.

If you need assistance, call 1-800-DIGITAL (1-800-344-4825)

DIRECT MAIL ORDERS (U.S. and Puerto Rico*)

DIGITAL EQUIPMENT CORPORATION
P.O. Box CS2008
Nashua, New Hampshire 03061

DIRECT MAIL ORDERS (Canada)

DIGITAL EQUIPMENT OF CANADA LTD.
940 Belfast Road
Ottawa, Ontario, Canada K1G 4C2
Attn: A&SG Business Manager

INTERNATIONAL

DIGITAL EQUIPMENT CORPORATION
A&SG Business Manager
c/o Digital's local subsidiary
or approved distributor

Internal orders should be placed through Publishing and Circulation Services (P&CS),
Digital Equipment Corporation, 444 Whitney Street, NRO2, Northboro, Massachusetts 01532-2597

*Any prepaid order from Puerto Rico must be placed
with the Local Digital Subsidiary:
809-754-7575

Please return this card.

Your comments and suggestions will help us improve the quality and usefulness of our documentation.

Did you use the manual as a reference or as a step by step procedure to install the device?

Were the instructions easy to follow? _____

Were the instructions complete? _____

Were they in the proper sequence? _____

Which chapters or sections were most helpful? _____

Did you use the appendices? Which ones? _____

Were the illustrations helpful? _____ All? _____ Some? _____ Which ones? _____

Were some illustrations unnecessary? _____ Which ones? _____

Do you think the manual needs more illustrations? _____ Please give an example. _____

Thank you.

Name _____ Date _____

Title _____ Department _____

Organization _____ Street _____

City _____ State/Country _____ Zip Code _____

DO NOT CUT – FOLD HERE AND TAPE

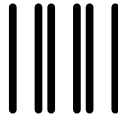

NO POSTAGE
NECESSARY
IF MAILED
IN THE
UNITED STATES

BUSINESS REPLY LABEL

FIRST CLASS PERMIT NO. 33 MAYNARD MASS.

POSTAGE WILL BE PAID BY ADDRESSEE

digitalTM

**Telecommunications and
Networks Publications**

550 King Street
Littleton, MA 01460–1289

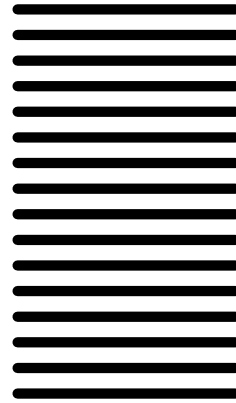

DO NOT CUT – FOLD HERE

digital

Printed in U.S.A.