

DEC FDDIcontroller/Q-bus

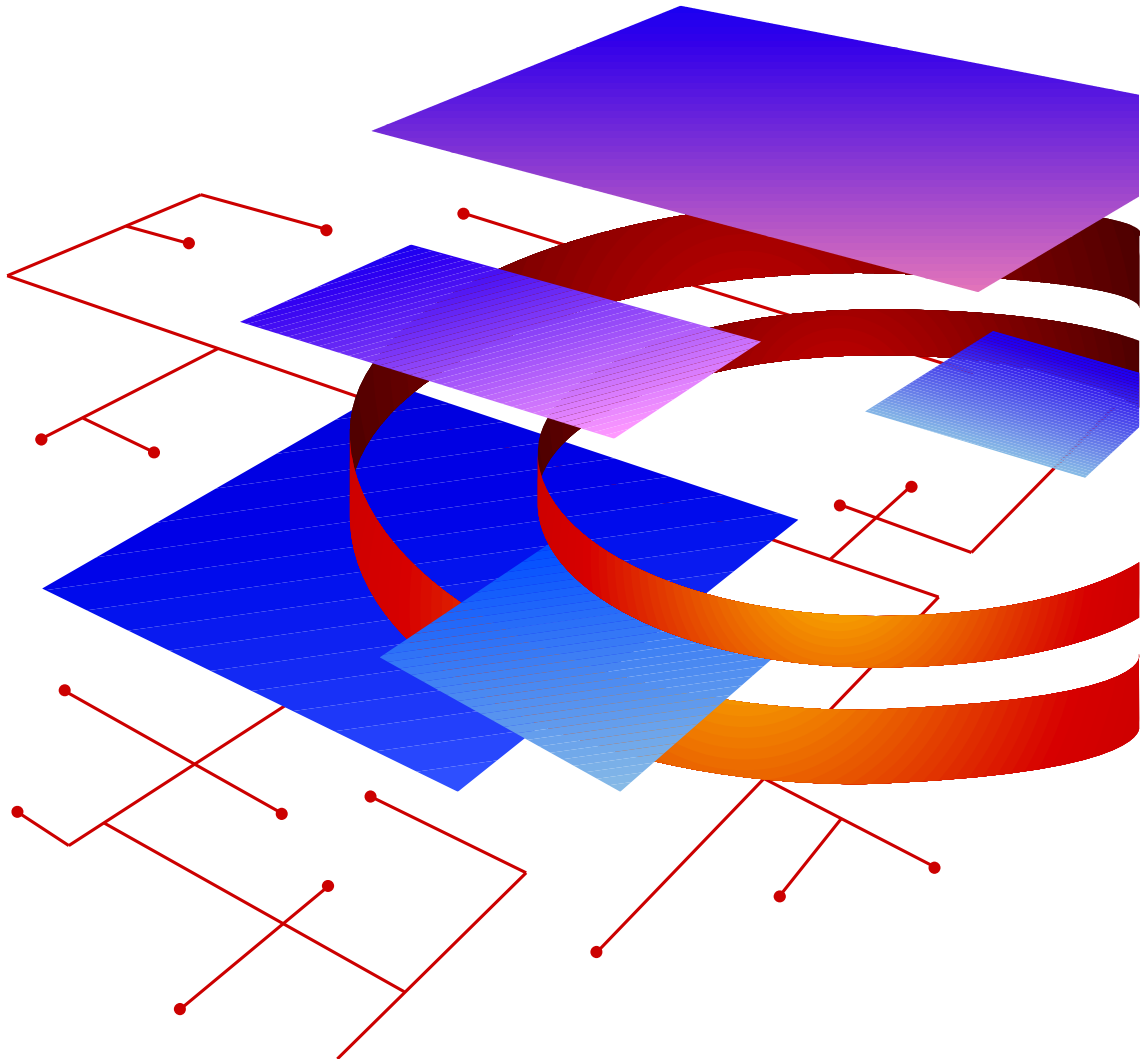

Installation



Order Number: EK-DEFQA-IN. A01

NOTICE – Class A Laser Device:

The lasers in this equipment are Class 1 devices, compliant with CDRH Rules 21, CFR Subchapter J, Part 1040.10, at date of manufacture. Class 1 laser devices are not considered to be hazardous.

NOTICE – Class A Computing Device:

This equipment generates, uses, and may emit radio frequency energy. The equipment has been type tested and found to comply with the limits for a Class A computing device pursuant to Subpart J of Part 15 of FCC Rules, which are designed to provide reasonable protection against such radio frequency interference when operated in a commercial environment. Operation of this equipment in a residential area may cause interference; in which case, measures taken to correct the interference are at the user's expense.

CAUTION

This equipment is in the 1st Class category (information equipment to be used in commercial and/or industrial areas) and conforms to the standards set by the Voluntary Control Council for Interference by Data Processing Equipment and Electronic Office Machines aimed at preventing radio interference in commercial and/or industrial areas. Consequently, when used in a residential area or in an adjacent area thereto, radio interference may be caused in radios and TV receivers, etc. Read the instructions for correct handling.

DEC FDDIcontroller/Q-bus

Installation

April 1993

This manual describes how to install and verify the operation of the DEC FDDIcontroller/Q-bus controller.

Supersession/Update Information: This is a new manual.

Order Number: EK-DEFQA-IN. A01

The information in this document is subject to change without notice and should not be construed as a commitment by Digital Equipment Corporation. Digital Equipment Corporation assumes no responsibility for any errors that may appear in this document.

Copyright © 1993 by Digital Equipment Corporation
All Rights Reserved.
Printed in U.S.A.

The following are trademarks of Digital Equipment Corporation:

DEC	DECnet
DECbridge	MicroVAX
DECconcentrator	OpenVMS
DECconnect	Q-bus
DECdirect	VAX
	VMS

This manual was produced by Telecommunications and Networks Publications.

Contents

Safety

Preface

1 Introducing the Controller

1.1	Overview	1-1
1.2	DEC FDDIcontroller/Q-bus Models Available from Digital ...	1-2
1.3	DEC FDDIcontroller/Q-bus Components	1-2

2 Unpacking the Controller

3 Adding the Controller to Your System Configuration

3.1	Verifying System Software	3-1
3.2	Determining the Current System Configuration	3-2
3.3	Configuring the System	3-3
3.4	Setting the CSR Address Switches	3-4

4 Installing the Controller

4.1	Preparing the System for Installation	4-1
4.2	Installing the Controller	4-3
4.3	Installing a Gap Filler	4-4
4.4	Connecting the FDDI Cable(s)	4-6
4.5	Dressing the FDDI Cabling	4-8
4.6	Installing the Driver	4-9
4.7	Verifying the Controller Installation	4-10
4.8	Verifying the FDDI Communications Connection	4-10

5 Troubleshooting the DEC FDDIcontroller/Q-bus

5.1	Running Self-test	5-1
5.2	Troubleshooting	5-1
5.3	Solving Hardware Problems	5-4

A MicroVAX Diagnostic Monitor (MDM) Diagnostics

A.1	Introducing the MicroVAX Diagnostic Monitor	A-1
A.2	How MDM Works	A-1
A.3	Performing MDM Testing	A-2
A.4	MDM Test Strategy	A-2
A.5	MDM Test Organization	A-3
A.5.1	MDM Verify Mode	A-3
A.5.2	MDM Service Mode	A-3
A.6	Test Sections	A-3
A.6.1	Functional Tests	A-3
A.6.2	Exerciser Tests	A-4
A.6.3	Utility Test	A-4
A.7	MDM Verify Mode Test Specifications	A-4
A.8	MDM Field Service Functional Test	A-4
A.9	MDM Field Service Exerciser Test	A-5

B FDDI Connector Keying and Optical Bypass Information

B.1	FDDI Multimode Connector Keying	B-1
B.2	Changing the Connector Key	B-2
B.3	Optical Bypass Connector	B-3

C Specifications

C.1	Power Requirements	C-1
C.2	Environmental Requirements	C-1

D Related Documentation

Index

Figures

1-1	Connecting the DEC FDDIcontroller/Q-bus to the FDDI Network	1-1
1-2	Controller Component Locations	1-2
1-3	Controller Connectors and LEDs	1-3
2-1	Shipping Package Contents	2-2
3-1	An Example of CSR Address Switch Settings (Top View)	3-5
4-1	Removing the Slot Cover	4-2
4-2	Inserting the Controller	4-4
4-3	Installing the Gap Filler	4-5
4-4	Connecting the FDDI Multimode Cable	4-8
4-5	Dressing the FDDI Cable	4-9
5-1	DEC FDDIcontroller/Q-bus Controller LED Locations	5-3
B-1	DEC FDDIcontroller/Q-bus MIC Receptacle Keying	B-1
B-2	Changing a PHY Port Key	B-2
B-3	Optical Bypass Control Signals	B-3

Tables

1-1	Controller Models	1-2
5-1	DEC FDDIcontroller/Q-bus FRU LED Displays	5-2
5-2	DEC FDDIcontroller/Q-bus PHY LED Displays	5-2
A-1	MDM Diagnostics Verify Mode Tests	A-4
C-1	DEC FDDIcontroller/Q-bus Power Requirements	C-1
C-2	DEC FDDIcontroller/Q-bus Environmental Requirements	C-1

Safety

Any warning or caution that appears in this manual is defined as follows:

Warning	Contains information to prevent personal injury.
Caution	Contains information to prevent damage to equipment.
Vorsicht	Enthält Informationen, die beachtet werden müssen, um den Benutzer vor Schaden zu bewahren.
Achtung	Enthält Informationen, die beachtet werden müssen, um die Geräte vor Schaden zu bewahren.
Danger	Signale les informations destinées à prévenir les accidents corporels.
Attention	Signale les informations destinées à prévenir la détérioration du matériel.
Aviso	Contiene información para evitar daños personales.
Precaución	Contiene información para evitar daños al equipo.

The warnings and cautions that you must observe for the hardware described in this manual appear below in English, German, French, and Spanish, along with the pages on which these safety messages appear.

CAUTION 

Static electricity can damage modules and electronic components. Digital recommends using a grounded antistatic wrist strap and a grounded work surface when handling any modules. [Page 2-1, 4-1, 4-3]

ACHTUNG

Module und elektronische Komponenten können durch elektrostatische Entladungen beschädigt werden. Benutzen Sie immer eine antistatische Gelenkmanschette und eine geerdete Arbeitsunterlage, wenn Sie am offenen Gerät arbeiten.

ATTENTION

Les charges excessives d'électricité statique peuvent endommager les modules et les composants électroniques. Digital conseille l'utilisation d'un bracelet de masse et d'un plan de travail mis à la terre lors de la manipulation des modules.

PRECAUCIÓN

La electricidad estática puede dañar los componentes electrónicos y los módulos. Digital recomienda que se utilicen cintas de pasadores y superficies de trabajo conectadas a tierra al trabajar con cualquier módulo.

WARNING 

Some fiber optic equipment can emit laser light that can injure your eyes. Never look into an optical fiber or connector port. Always assume the cable is connected to a light source.
[Page 4-6]

VORSICHT

Schauen Sie niemals direkt in ein Glasfaserkabel oder einen Glasfaseranschluß. Die Laserstrahlen in faser-optischen Geräten können Augenverletzungen verursachen.

DANGER

Certains équipements utilisant les fibres optiques peuvent émettre des rayonnement laser dangereux pour les yeux. Ne vous avisez jamais de regarder par l'extrémité d'une fibre optique ou dans l'ouverture d'un connecteur. Considérez toujours que le câble est relié à une source lumineuse.

AVISO

Algunos equipos de fibra óptica pueden emitir luz láser que daña los ojos. No se debe mirar en una puerta de conector o fibra óptica. Siempre se debe suponer que el cable está conectado a la luz.

WARNING 

To prevent personal injury or equipment damage, **do not** insert telecommunications cabling into the optical bypass relay connector. [Page B-3]

VORSICHT

Um Personen oder Geräteschäden zu vermeiden, dürfen Sie das Telefonkabel **AUF KEINEN FALL** am Anschluß des optischen Bypass-Relais anschließen.

DANGER

Pour éviter tout risque d'accident corporel ou de dommage matériel, **NE BRANCHEZ PAS** de câble de télécommunication sur le connecteur de relais sélectif optique (optical bypass relay connector).

AVISO

Para evitar daños personales o al equipo, **NO** se debe introducir cableado de telecomunicaciones en el conector óptico de relés de derivación.

Preface

This manual describes how to configure and install the DEC FDDIcontroller/Q-bus into Q-bus-based MicroVAX and VAX systems. It also shows how the controller connects to an FDDI network.

Intended Audience

This manual is intended for qualified service personnel who repair Q-bus-based MicroVAX and VAX systems. This manual assumes that you are familiar with the DEC FDDIcontroller/Q-bus and understand the concepts and uses of an FDDI network.

Structure of This Manual

This guide has five chapters and four appendixes:

- Chapter 1** Contains an overview and description of the DEC FDDIcontroller/Q-bus.
- Chapter 2** Contains unpacking information and controller kit contents.
- Chapter 3** Describes the hardware configuration procedure.
- Chapter 4** Describes the installation procedure.
- Chapter 5** Contains troubleshooting procedures.
- Appendix A** Explains how to use the MicroVAX Diagnostic Monitor.
- Appendix B** Contains connector keying and optical bypass switch information.

- Appendix C** Contains DEC FDDI controller/Q-bus specifications.
- Appendix D** Lists related documents.

Conventions Used in This Manual

The following conventions are used in this manual.

`Special type` Indicates a literal example of system output.

bold Indicates a command format that you must enter.

Key Indicates that you press the specified key. For example, *Ret* means that you should press the Return key.

The postage-paid **Reader's Comments** form on the last page of this document requests your critical evaluation to assist us in preparing future documentation.

Introducing the Controller

This chapter describes the DEC FDDIcontroller/Q-bus network device (hereafter called the DEC FDDIcontroller/Q-bus or controller). It also includes unpacking information for the controller shipping package.

1.1 Overview

The DEC FDDIcontroller/Q-bus allows the transmission of data from Q-bus-based MicroVAX and VAX systems to a 100-Mb/s FDDI network. Depending on the model and the topology, the controller can serve as either a SAS (Single Attachment Station) or a DAS (Dual Attachment Station) connection to the network (see Figure 1-1). A SAS connection connects through a fiber optic cable to an FDDI-compliant concentrator (such as the DECconcentrator 500). A DAS connection connects directly to the FDDI network.

Figure 1-1: Connecting the DEC FDDIcontroller/Q-bus to the FDDI Network

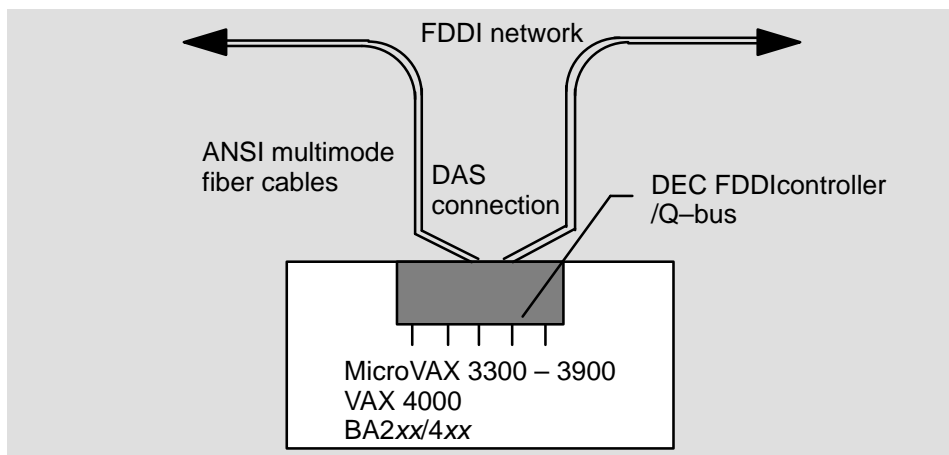

LKG-7984-92I

1.2 DEC FDDIcontroller/Q-bus Models Available from Digital

Table 1–1 lists and describes the DEC FDDIcontroller/Q-bus models available from Digital Equipment Corporation.

Table 1–1: Controller Models

Part Number	Module Number	Description
DEFQA-SF	M7534-AS	One card, single attachment station (SAS) controller with multimode optics for 1 ANSI MIC connector
DEFQA-DF	M7534-DS	One card, dual attachment station (DAS) controller with multimode optics for 2 ANSI MIC connectors

1.3 DEC FDDIcontroller/Q-bus Components

Figure 1–2 shows component locations. Figure 1–3 shows connectors and LEDs.

Figure 1–2: Controller Component Locations (DAS module shown)

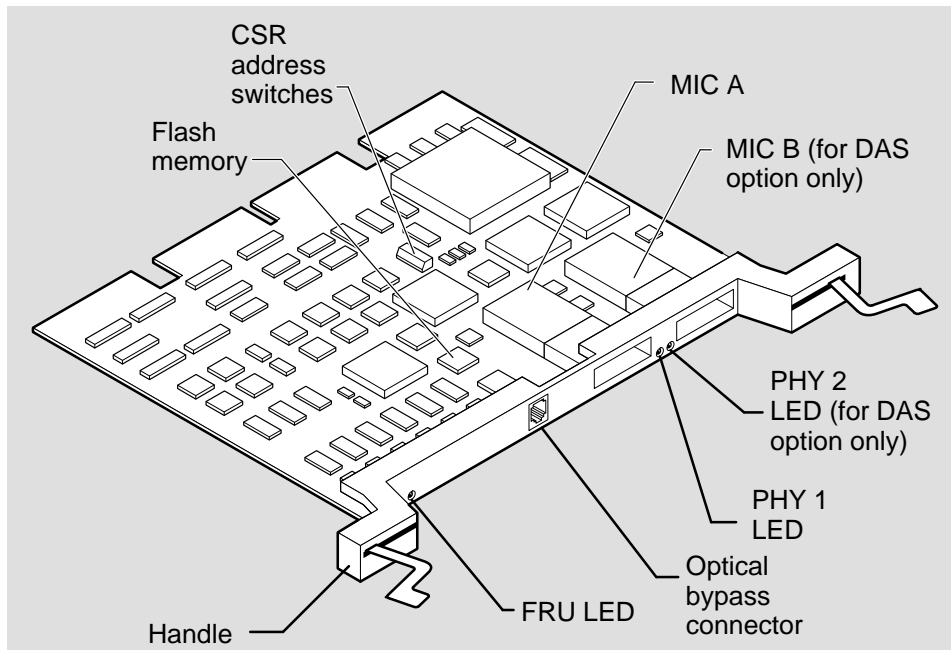

LKG-7985-93I

Figure 1-3: Controller Connectors and LEDs

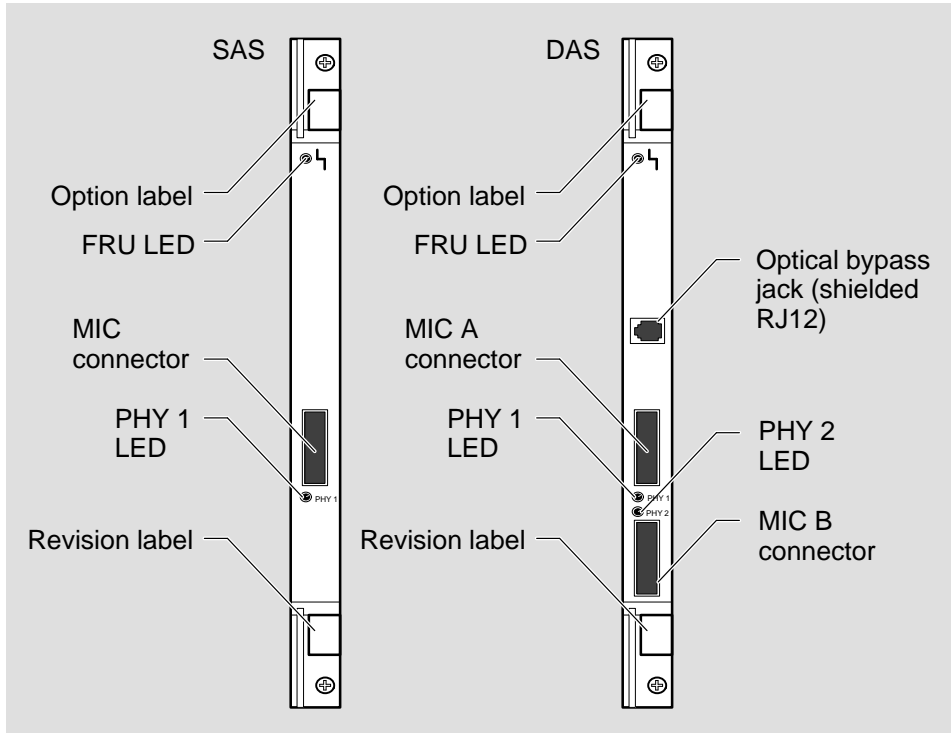

LKG-7986-921

Unpacking the Controller

The DEC FDDI controller/Q-bus is shipped in one box (see Figure 2-1 for contents). Remove the contents from the box and place it nearby on an antistatic mat until you are ready to install it.

Check the shipment for damage and missing parts. In case of damage, contact your delivery agent and your Digital sales representative. If parts are missing, contact your Digital sales representative.

CAUTION

Static electricity can damage modules and electronic components. Digital recommends using a grounded antistatic wrist strap and a grounded work surface when handling any modules.

Figure 2-1: Shipping Package Contents

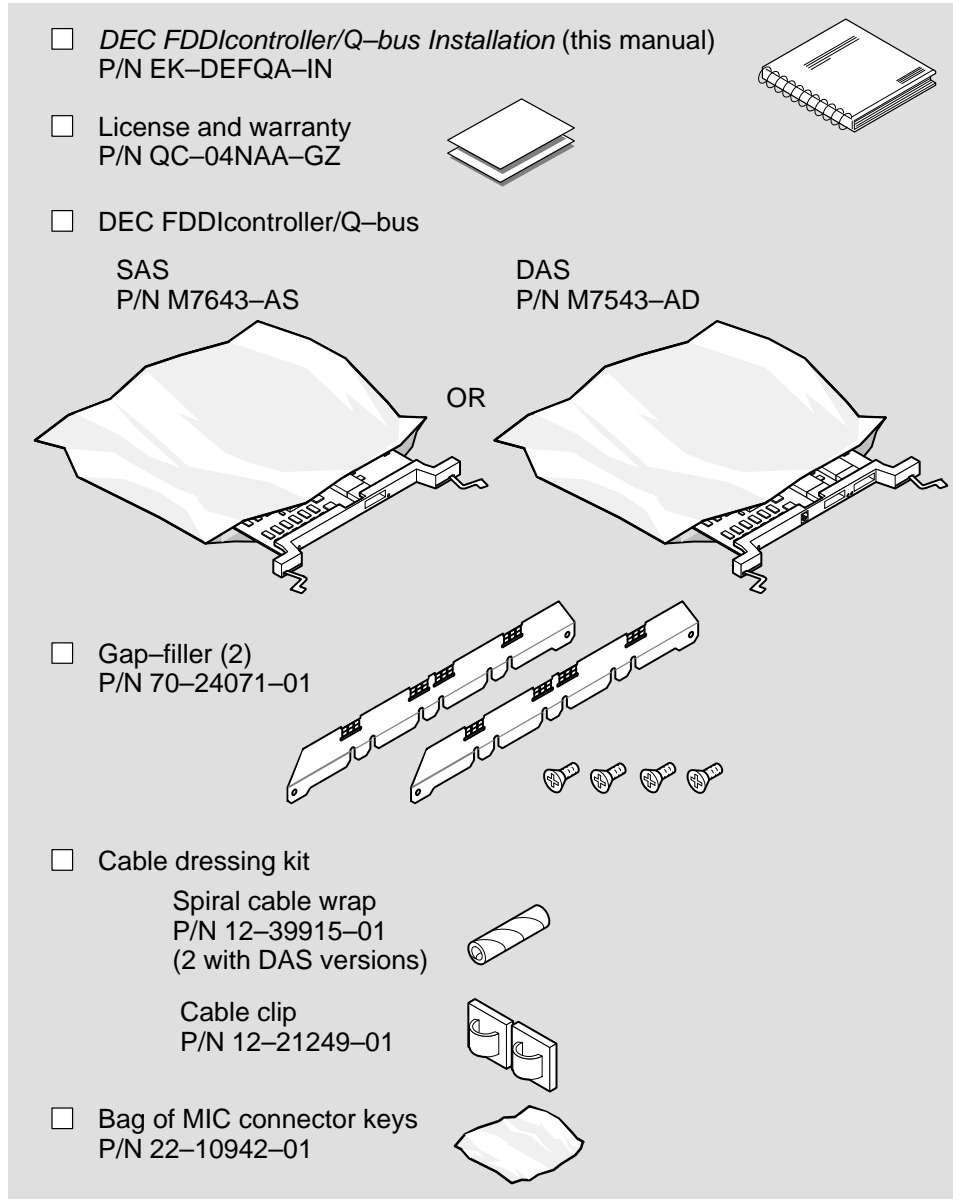

LKG-7987-931

Adding the Controller to Your System Configuration

This chapter explains how to add your DEC FDDIcontroller/Q-bus to your host system configuration. Perform this procedure before installing the controller hardware into the system unit. Configuring your system involves the following steps:

1. Verifying system software
2. Determining your current configuration
3. Configuring the system
4. Setting the DEC FDDIcontroller/Q-bus address switches

3.1 Verifying System Software

Before installing the controller, ensure you have the following prerequisite software on your system:

- OpenVMS VAX operating system Version 5.5-2
- DEC FDDIcontroller/Q-bus driver files installed on the system

You must use the correct version of the OpenVMS VAX operating system and also have the controller driver files installed on your system for the controller to work properly. The DEC LAN Device Driver Kit for OpenVMS VAX Version 1.0 (P/N QA-OPAAA) contains the DEC FDDIcontroller/Q-bus driver files. The kit includes VMSINSTAL instructions for loading the driver into your system.

If your version of the OpenVMS VAX operating system is lower than Version 5.5-2, or you have OpenVMS VAX operating system Version A5.5-2, or you do not have the driver files and need the device driver kit, contact Digital services.

NOTE

A future release of the OpenVMS VAX operating system will contain the DEC FDDIcontroller/Q-bus driver files. When that version of the operating system becomes available, you will not need a device driver kit. Contact Digital services for more information.

3.2 Determining the Current System Configuration

You obtain the system CSR and vector address of all system options (excluding your Q-bus controller) using OpenVMS and running `SYSGEN`.

1. Using OpenVMS, enter the following commands at the DCL prompt (\$) to get to the system account:

```
$ RUN SYS$SYSTEM::SYSGEN  OR $ MCR SYSGEN 
```

OpenVMS system places you at the `SYSGEN>` prompt.

2. To display the current system configuration of all system options, enter the following command:

```
SYSGEN> SHOW/CONF 
```

This command returns the device name, number of units, CSR address, and the vector number of all system devices. The following is an example of the entire `SHOW CONFIGURATION` process:

```
$ RUN SYS$SYSTEM:SYSGEN 
```

```
SYSGEN> SHOW/CONF 
```

System CSR and Vectors

```
Name: PIA Units: 1 NEXUS: 0 (640)
```

```
Name: ESA Units: 1 NEXUS: 0 (640)
```

```
Name: PUA Units: 1 NEXUS: 1 (UBA) CSR: 772150 Vector 1: 154 Vector 2: 000
```

```
Name: PIA Units: 1 NEXUS: 1 (UBA) CSR: 774500 Vector 1: 260 Vector 2: 000
```

```
Name: TXA Units: 8 NEXUS: 1 (UBA) CSR: 760440 Vector 1: 300 Vector 2: 304
```

```
Name: PKA Units: 1 NEXUS: 1 (UBA) CSR: 761300 Vector 1: 310 Vector 2: 000
```

3.3 Configuring the System

To add the controller to your system configuration, perform the following steps:

1. Enter `CONFIG` at the `SYSGEN` prompt to get the `DEVICE` prompt:

```
SYSGEN> CONFIG   
DEVICE>
```

2. Enter each device name in your system configuration at the `DEVICE` prompt and also *add* the DEC FDDIcontroller/Q-bus to the configuration as shown in the following example:

```
SYSGEN> CONFIG   
Device: UDA   
Device: ???   
Device: ???   
Device: ..others....   
Device: FQA 
```

NOTE

If you receive an error message “unknown device,” you do not have the correct version of the OpenVMS VAX operating system or correct version of the driver kit (refer to Section 3.1). Contact Digital services and obtain a copy of the correct version before continuing with this procedure.

3. Press `CTRL/Z` to exit from the configuration process. The system configuration then displays the CSR address and vector values for the devices entered during the configuration process, including the controller (see the following example). Write down the CSR value for the controller. You need this value for setting the controller switches. Note that the address is in octal notation (three binary bits per octal digit).

```
Device: ??? Name: PIA Units: 1 NEXUS: 0 (640)
Device: ??? Name: ESA Units: 1 NEXUS: 0 (640)
Device: UDA Name: PUA Units: 1 NEXUS: 1 (UBA) CSR: 772150 Vector 1: 154
Vector 2: 000
Device: ??? Name: PIA Units: 1 NEXUS: 1 (UBA) CSR: 774500 Vector 1: 260
Vector 2: 000
Device: ??? Name: TXA Units: 8 NEXUS: 1 (UBA) CSR: 760440 Vector 1: 300
Vector 2: 304
Device: ??? Name: PKA Units: 1 NEXUS: 1 (UBA) CSR: 761300 Vector 1: 310
Vector 2: 000
Device: FQA Units: 1 NEXUS: 1 (UBA) CSR: 761400* Vector 1: 330 Vector 2: 000
```

* These are the locations the system is expecting to find the controller. Set the controller CSR address switches to the CSR address value displayed.

4. Power down the system and proceed to setting the controller CSR address switches.

NOTE

If you have a console for the VAX 4000, you can configure the system using the CONFIG console utility. Refer to your system documentation for more information on this utility.

3.4 Setting the CSR Address Switches

The controller has seven switches that control the CSR address bits (see Figure 3-1). Switch 8 is not used. Set the switches to the address displayed during the configuration process (Section 3.3).

There are 22 CSR address bits. The Q-bus module switches control CSR address bits 6 through 12 only. All other bits are controlled by software. For example, if the CSR address is 761400, the switches are set to those shown in Figure 3-1. Once you have set the switches, install the controller into the system unit by following instructions in Chapter 3.

NOTE

Note that you must set the switches using the binary value of the address. An UP (open) setting is equal to a *binary zero* and a DOWN setting is equal to a *binary one*.

Figure 3–1: An Example of CSR Address Switch Settings (Top View)

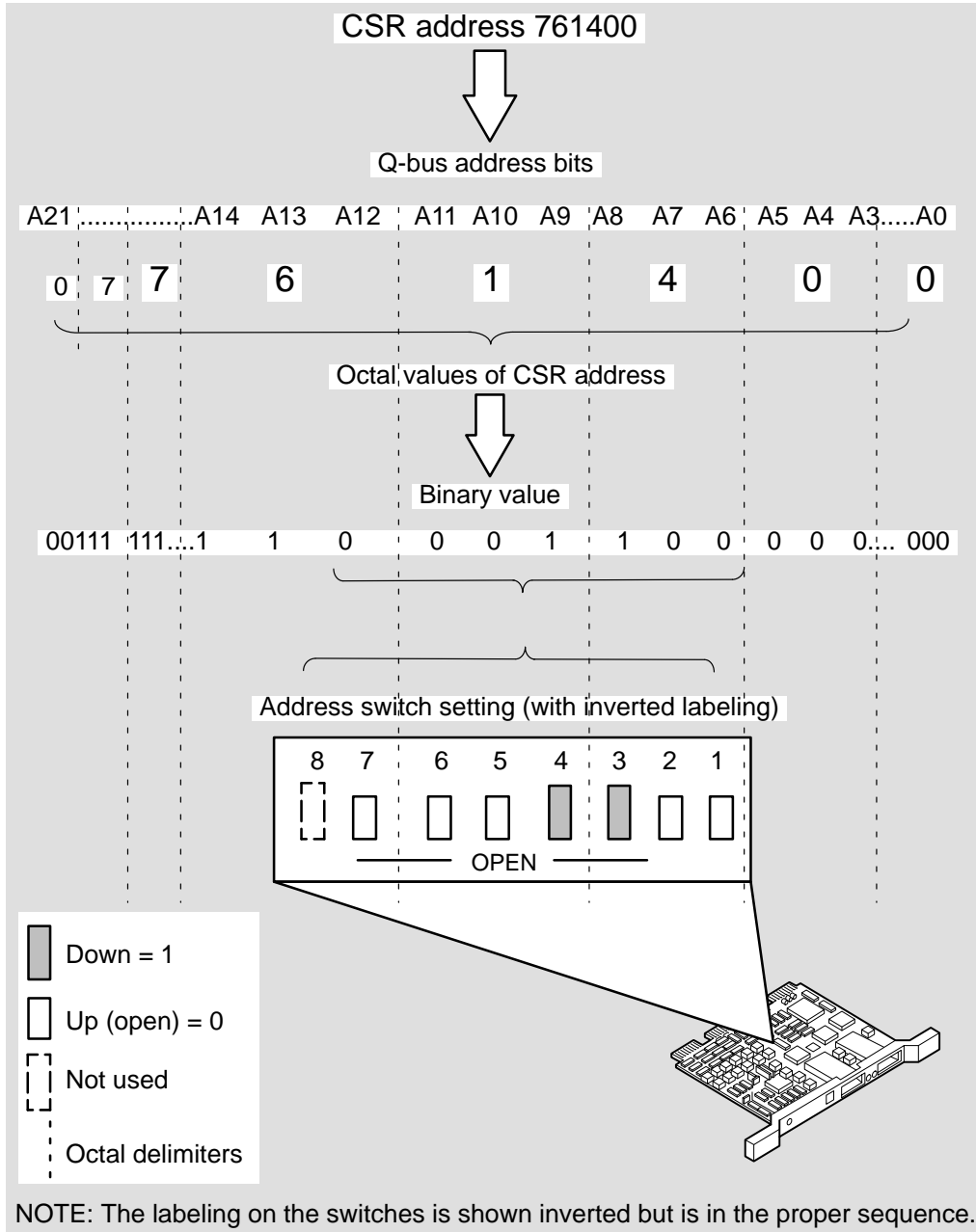

LKG-7988-921

Installing the Controller

This chapter explains how to install the DEC FDDI controller/Q-bus. Installation includes the following steps:

1. Preparing the system for installation
2. Installing the controller
3. Verifying the ground connections
4. Verifying the controller installation
5. Connecting FDDI communications cables
6. Verifying the FDDI communications connection

CAUTION

Static electricity can damage modules and electronic components. Digital recommends using a grounded antistatic wrist strap and a grounded work surface when handling any modules.

4.1 Preparing the System for Installation

To prepare the system for installation, you need a Phillips-head screwdriver and an antistatic wrist strap kit, then perform the following:

1. Ensure the system is powered off.

2. Open the system unit. Refer to your system documentation for instructions on how to do this.
3. Remove the slot cover from the slot you are installing the controller (see Figure 4-1). Use a Phillips-head screwdriver to unfasten the two quarter-turn screws that hold the slot cover in place. Save this cover for future use.

Figure 4-1: Removing the Slot Cover

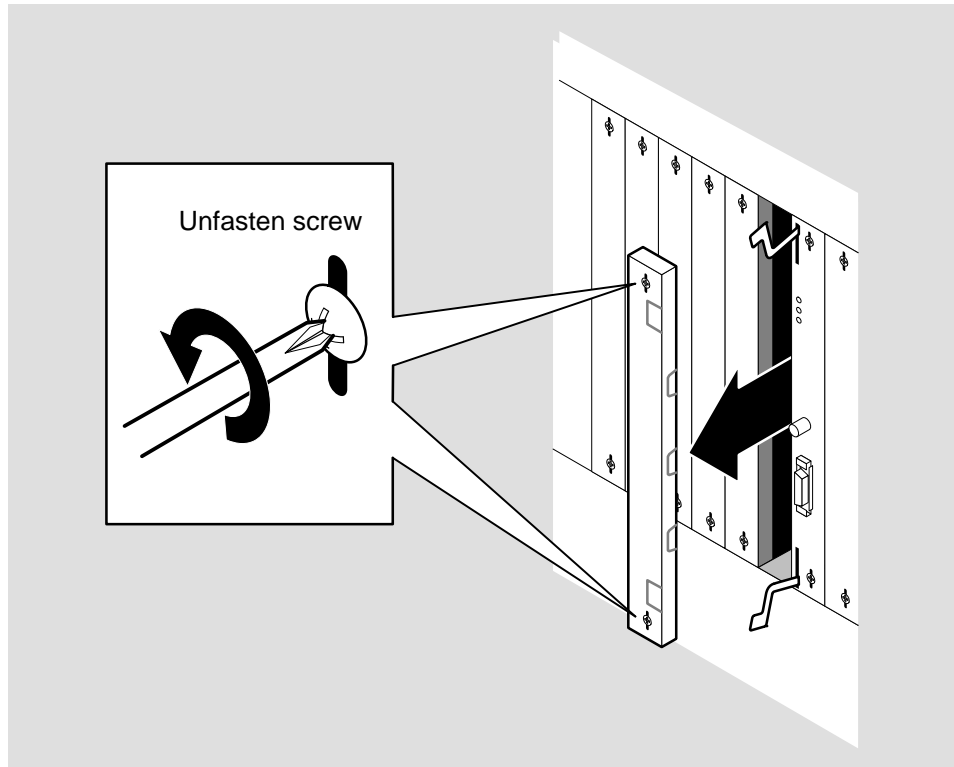

LKG-7989-931

4.2 Installing the Controller

To install the controller, perform the following steps:

CAUTION

Static electricity can damage modules and electronic components. Digital recommends using a grounded antistatic wrist strap and a grounded work surface when handling any modules.

1. Attach one end of the ESD wrist strap to your wrist and the other end to the system.

NOTE

Install the controller as close to the system processor as possible to maximize controller performance.

2. Insert the controller into the appropriate slot with the FRU LED at the top (see Figure 4–2).
3. Lock the controller in place by simultaneously pushing the top lever down and pulling the bottom lever up.
4. Fasten the quarter-turn captive screws.
5. Remove the antistatic wrist strap from your wrist and the system unit.

Figure 4-2: Inserting the Controller

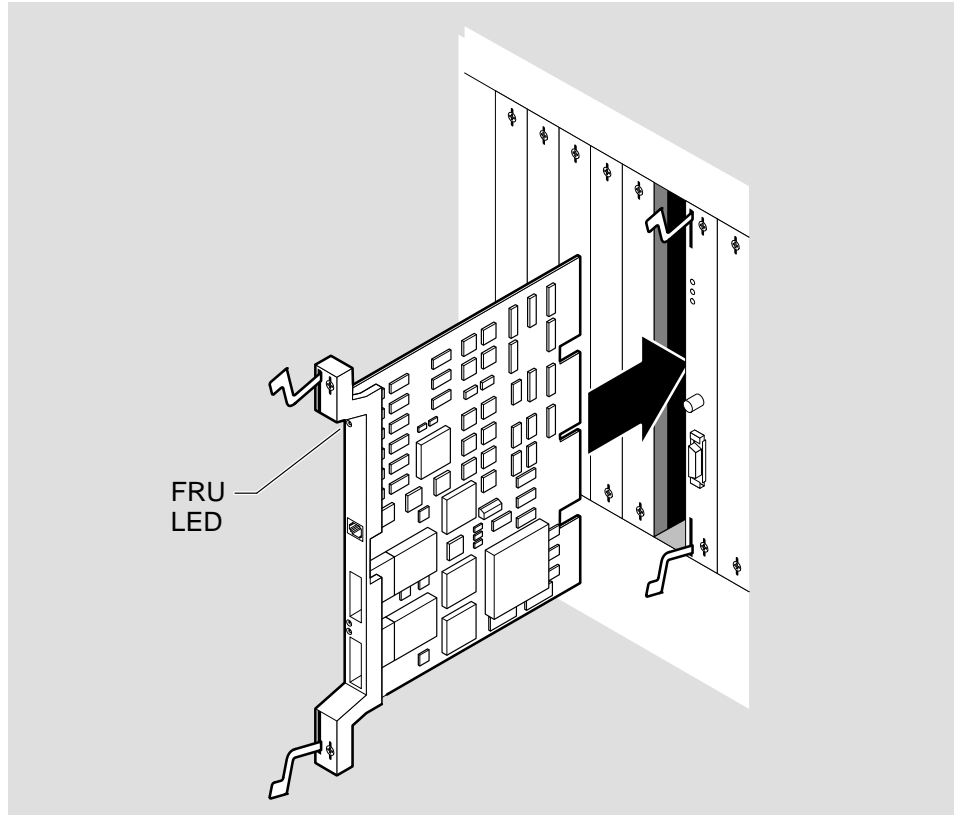

LKG-7990-93I

4.3 Installing a Gap Filler

If you install the controller and notice a gap or air space next to it, you *must* install a gap filler to fill in gaps and meet electromagnetic interference (EMI) regulations.

If the modules surrounding the FDDI module are recessed and have no gaps, you do not install a gap filler. Proceed to Section 4.4.

To correct the EMI problem, install the gap fillers provided in the controller kit. Each gap filler comes with two screws. Use one or both gap fillers to make your configuration comply with EMI regulations.

To install a gap filler:

1. Remove the affected blank slot cover or flush-handle module on either side of the FDDI module.
2. Fit the gap filler onto the side of the blank cover or flush-handle module that is *next* to the FDDI module. Make sure the gap filler's tabs fit into the tab indentations on the blank cover or flush handle (see Figure 4–3). Attach the gap filler with two screws provided in the kit.
3. Reinstall the blank slot cover or module containing the gap filler next to the FDDI module (from where it was removed).
4. Fasten the quarter-turn captive screws on all handles and covers in the back-plane.

Figure 4–3: Installing the Gap Filler

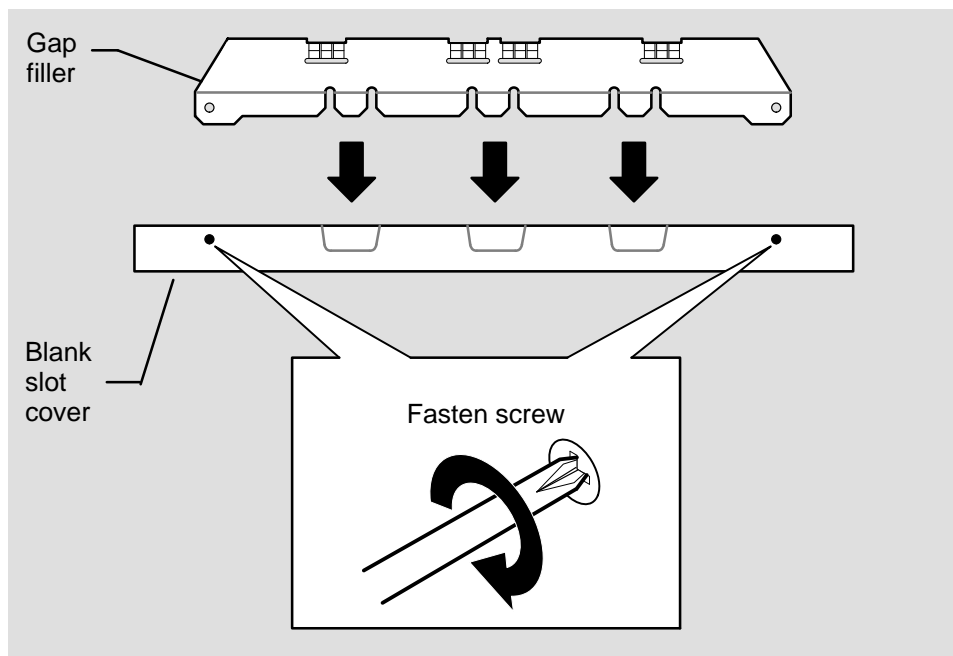

LKG-7991-93I

4.4 Connecting the FDDI Cable(s)

The controller has one (SAS) or two (DAS) FDDI connectors, depending on the model. Both the SAS and DAS versions of the controller ship with S-type connector keys. You can change the keying in the connectors to meet your needs (refer to Appendix B).

You can also connect the controller in different configurations. The following list provides useful information for installing the controller:

- In a SAS controller connection, Port S of the controller connects to Port M of a concentrator.
- If you have a DAS controller:
 - Connect controller Port A to adjacent station, Port B.
 - Connect an adjacent station Port A to controller Port B.
- If you have a DAS controller in a dual homing configuration:
 - Connect the controller Port B to either Port A or Port M on Concentrator #1 or an adjacent device.
 - Connect the controller Port A to Port M of Concentrator #2.
- If you are using a DAS controller as a SAS:
 - Connect the FDDI cable to either port on the DEC FDDI controller/Q-bus controller.
 - The least amount of station delay occurs when connecting to Port A on the controller.

WARNING

Some fiber optic equipment can emit laser light that can injure your eyes. Never look into an optical fiber or connector port. Always assume the cable is connected to a light source.

NOTE

Digital recommends using Digital's multimode FDDI-to-FDDI patch cables (BN24B-*nm*) for multimode connections.

NOTE

The controller is shipped with S-type connector key(s). If you want to change the key(s), refer to instructions included in Appendix B.

To install the FDDI cable(s), perform the following:

1. Remove the protective optical dust cover from the FDDI connector receptacle by squeezing the locking clips on the sides and pulling it out (see Figure 4-4).
2. Insert the FDDI cable connector into the receptacle (with proper keying), making sure the locking clips on the sides snap into the locked position (see Figure 4-4).
3. If you are connecting to the dual ring through a concentrator, verify that the other end of this cable is connected to the concentrator (such as the DECconcentrator 500). If it is not connected, refer to the appropriate concentrator manual or *Fiber Distributed Data Interface (FDDI) Network Configuration Guidelines* for connection information. Proceed to Section 4.5 and dress the cables before closing the system.

NOTE

If you are installing a DAS controller and you are using the optical bypass feature, refer to the installation instructions included with the optical bypass switch to install the switch.

NOTE

A controller can be cabled to a patch panel device first but must then be cabled from the panel to the appropriate concentrator or connect directly to a ring to complete proper connection of the controller to an FDDI ring.

Figure 4-4: Connecting the FDDI Multimode Cable

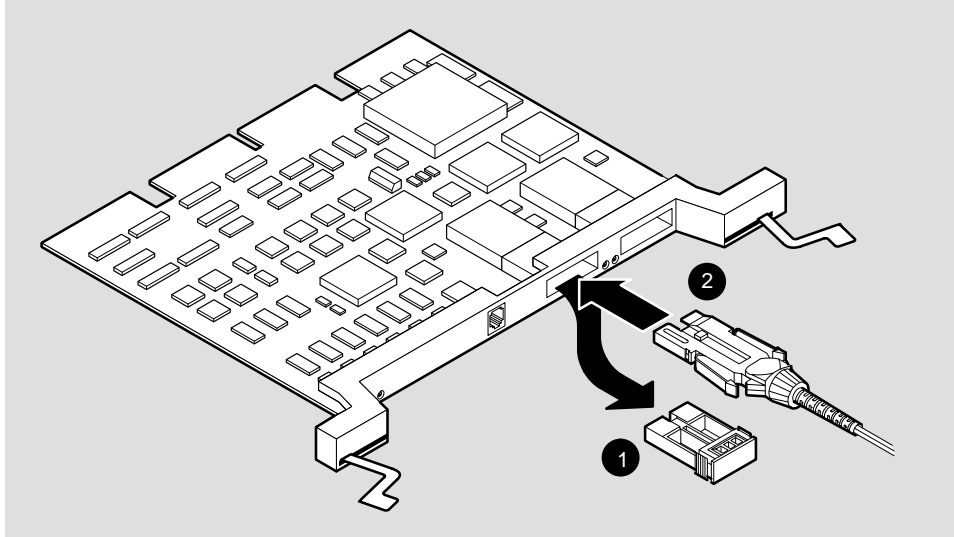

LKG-7992-93I

4.5 Dressing the FDDI Cabling

Use the cable dressing kit included in the controller shipping package to ensure that the FDDI cable is installed properly and meets bend radius requirements. When cabling the controller, be sure to use the plastic spiral cable wraps on the cable to provide at least a 2 1/4-inch radius turn in the FDDI cable. This prevents crimping of the cable. The cable dressing kit includes two stick-on cable clips and one (or two for DAS versions) plastic spiral cable wrap.

To install the cable dressing kit:

1. Twist a plastic spiral cable wrap around the end of the cable next to the connector (see Figure 4-5). Make sure approximately half of the cable wrap covers the existing cable restraint.

NOTE

If your cable has a connector keys holder, slide the holder up the cable to allow room for the cable wrap.

2. Remove the peel-and-stick backing from the cable clip and attach the clip below the card cage area onto the frame of the unit (see Figure 4-5).

3. Place the cable into the clip. Make sure the cable feeds out through the bottom of the unit.

Figure 4-5: Dressing the FDDI Cable

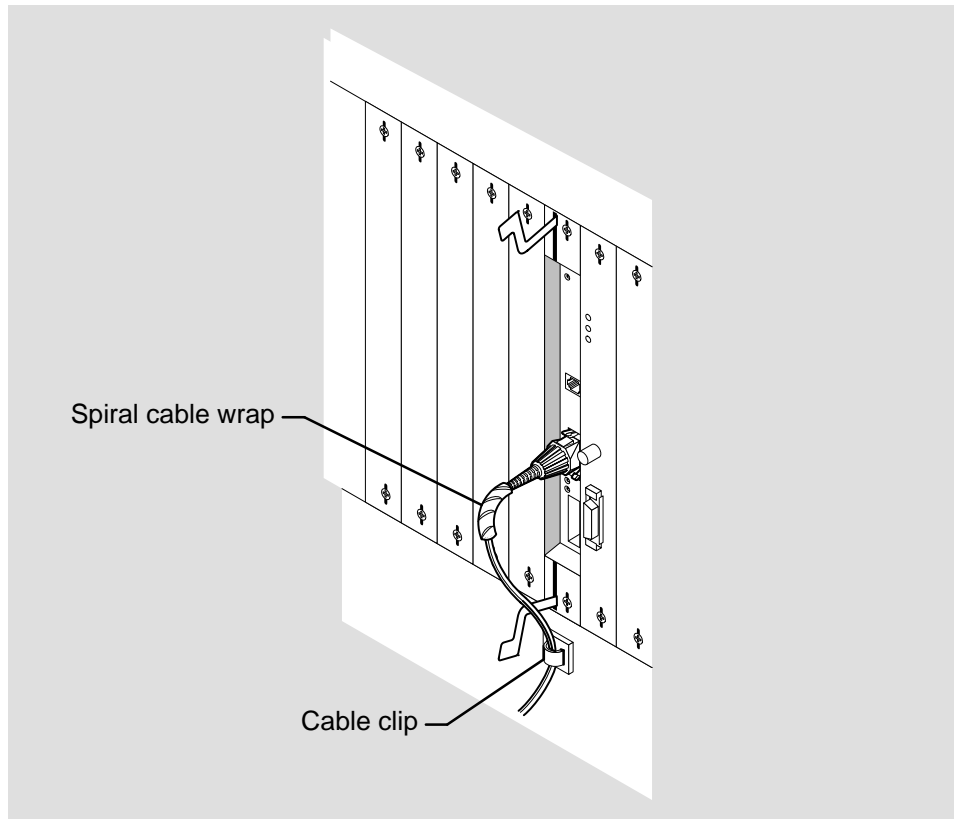

LKG-7993-931

4.6 Installing the Driver

Verify that you have DEC FDDIcontroller/Q-bus driver files installed on your system. The DEC LAN Device Driver Kit for OpenVMS VAX Version 1.0 (P/N QA-OPAAA) contains the DEC FDDIcontroller/Q-bus driver files. The kit includes VMSINSTAL instructions for loading the driver files into your system. If the files are not installed, refer to the instructions included with the driver kit and perform the procedure at this time.

NOTE

A future release of the OpenVMS VAX operating system will contain the DEC FDDIcontroller/Q-bus driver files. When that version of the operating system becomes available, you will not need a device driver kit. Contact Digital services for more information.

4.7 Verifying the Controller Installation

To verify the hardware installation, apply power and boot the host system. Observe the FRU LED on the controller.

The LED should be RED during self-test. At the end of self-test, the LED should change to BLINKING GREEN, indicating the controller has passed self-test and the driver is loading. When complete, the FRU LED changes to SOLID GREEN.

4.8 Verifying the FDDI Communications Connection

Verify the FDDI communications connection by performing the following:

1. Ensure the system is powered on.
2. Verify that the LEDs are working. The FRU and PHY LEDs should be SOLID GREEN, indicating the controller is fully functional (the interrupt vector register is programmed properly and the controller can communicate with the Q-bus).

NOTE

The PHY LED for an unused port on DAS versions will be BLINKING GREEN.

If the LEDs are lit correctly and you can send and receive communications, your controller installation is complete. Close the system unit.

If the LEDs are not lit correctly or you are having problems with the network connection, refer to Chapter 5 for troubleshooting information.

Troubleshooting the DEC FDDIcontroller/Q-bus

This chapter explains how to troubleshoot the controller. It contains the LED display and other general information to help determine the source of a problem.

5.1 Running Self-test

Self-test is initiated at power up. It consists of a series of on-board diagnostic tests to verify the operation of the controller after installation. This ensures that the controller is working properly.

Self-test checks everything on the controller except the host interface circuitry. If you want to perform testing on the interface circuitry or the operational software detects a problem and displays an error message, use the MicroVAX diagnostic monitor (MDM) diagnostics to test the host interface circuitry of the controller. Refer to Appendix A for information on MDM diagnostics.

5.2 Troubleshooting

To determine the source of a problem, perform the following:

1. Initiate self-test by turning the system power off and then back on. Self-test takes approximately 6 seconds. This verifies that the problem with your controller still exists.
2. Refer to Table 5-1 and Table 5-2 to find the LED state your module is currently displaying. Figure 5-1 shows the controller LEDs.

Table 5–1: DEC FDDIcontroller/Q-bus FRU LED Displays

FRU LED State	State Description	Correction
ON (RED)	Power up/fail state; self-testing mode.	Wait for testing to complete (approx. 6 seconds).
	Self-test failure.	Rerun self-test. Also, run the MDM diagnostic tests.
	Bad module.	Contact your Digital services representative.
ON (BLINKING RED)	A problem exists with the controller.	Rerun self-test.
	Module broken.	Contact your Digital services representative.
OFF	Power is off.	Turn power on.
ON (GREEN)	Passed self-test. Controller is working correctly.	None.
ON (BLINKING GREEN)	Passed self-test. Waiting for driver installation or further testing (MDM).	Wait for driver installation or testing to complete.

Table 5–2: DEC FDDIcontroller/Q-bus PHY LED Displays

PHY LED state	State Description	Correction
OFF	Port not available. Software configuring not complete.	None.
ON (RED)	Broken port or LCT* failure.	Run self-test.
ON (GREEN)	Standby; controller is working correctly.	None.
ON (BLINKING RED)	Illegal topology.	Cables not installed correctly.
ON (BLINKING GREEN)	Connection in progress or link available but cannot make a connection.	Wait for connection.
		Verify cable connections.
		Port not being used.

* Link Confidence Test

3. Follow the suggested corrective actions provided in the previous tables.

If you need to perform interface circuitry testing, proceed to Appendix A and perform the MicroVAX Diagnostics Monitor (MDM) diagnostics.

If your controller appears to be functioning properly but you still have problems, proceed to Section 5.3 and perform general problem solving procedures. Your controller may not be the source of the problem.

Figure 5-1: DEC FDDIcontroller/Q-bus Controller LED Locations

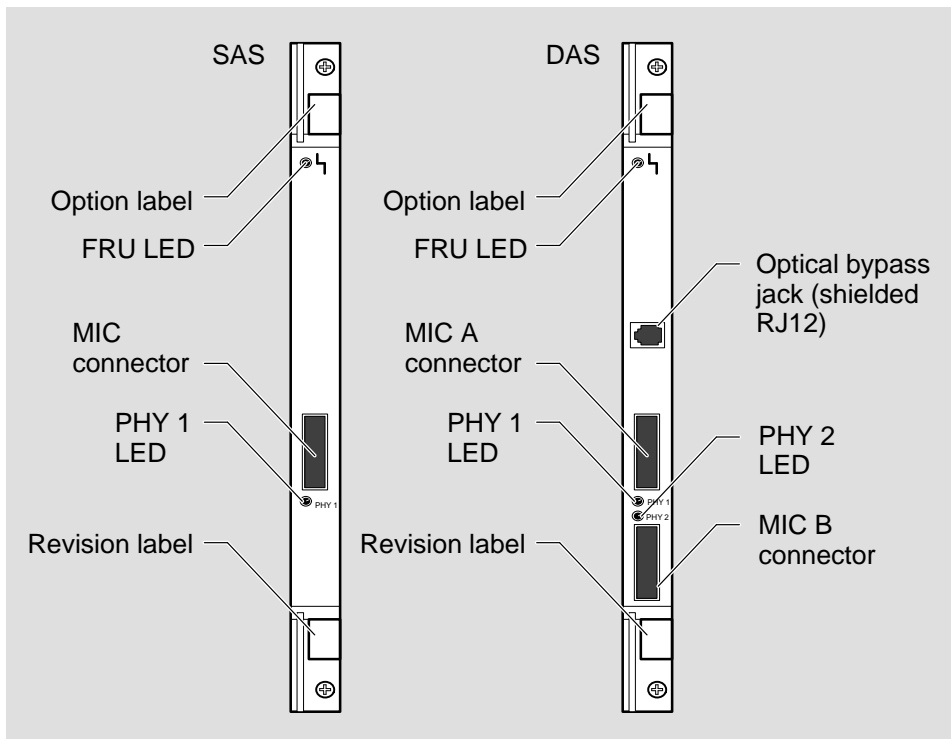

LKG-7986-921

5.3 Solving Hardware Problems

The following list provides possible solutions to a number of hardware problems:

- Be sure that the controller is inserted tightly in its slot and that anything connected to it is connected correctly.
- Be sure the FDDI controller is installed as close as possible to the system processor and there are no gaps.
- Be sure there are no open slots. Each slot should contain either a module or grant continuity module (that maintains the integrity of request lines).

If the problem persists after trying these suggestions, contact Digital services.

MicroVAX Diagnostic Monitor (MDM) Diagnostics

This appendix describes the MicroVAX Diagnostic Monitor (MDM) diagnostics for the DEC FDDIcontroller/Q-bus.

A.1 Introducing the MicroVAX Diagnostic Monitor

MDM is standalone VAX software that you use to configure and check the integrity of DEC FDDIcontroller/Q-bus module. In particular, it performs testing beyond the scope of self-test. It verifies the host interface circuitry.

A.2 How MDM Works

MDM verifies that individual devices and complete systems are functioning correctly. If they are not, MDM isolates problems to a failing field replaceable unit (FRU). The controller's ROM-based tests verify its hardware — not its functional operation.

MDM is designed to complement self-test and test the controller's interface (bus addressing, registers, interrupts, and direct memory access [DMA]), and help configure the entire system. MDM can initiate the device's built-in self-test and report the results.

MDM can do the following:

1. Initiate self-test
2. Report status of self-test
3. Configure interrupt vector
4. Check all Q-bus registers
5. Perform the DMA operation

A testable device may be either a Digital-supported device that is attached to the system within standard CSR and vector address ranges or a device that does not comply with Digital-recommended vector addresses but is part of the MDM's database.

A.3 Performing MDM Testing

Customer service and self-maintenance customers use MDM to perform extensive, customized testing of newly installed or faulty Q-bus systems. The MDM software designed for the DEC FDDIcontroller/Q-bus has specific tests and modes to accommodate controller manufacturing personnel and the end user.

To perform MDM testing, follow the instructions included with the MDM software.

A.4 MDM Test Strategy

The recommended test strategy for identifying faulty FRUs is as follows:

- Check the MDM configuration listing for the correct DEC FDDIcontroller/Q-bus details.
- Run the Verify Mode tests (Functional, Exerciser, and Utility) to check controller functions.
- Run the Field Service Functional tests if you need detailed fault-finding to identify a faulty FRU.

A.5 MDM Test Organization

MDM's diagnostic tests run in two modes:

- Verify mode
- Service mode

A.5.1 MDM Verify Mode

Verify Mode tests provide a quick check of device function. These tests never destroy data and require no user intervention. In some cases, these restrictions limit the coverage provided by Verify Mode tests.

A.5.2 MDM Service Mode

Service Mode tests are more rigorous than the Verify Mode tests. Some Service Mode tests destroy data and must be used carefully. They often require you to modify device hardware. If they do, you are prompted to perform the *setup* procedure. The setup procedure involves installing loopback connectors on communication lines.

When a setup is needed, the diagnostic describes the procedure, then waits for completion of the set procedure.

A.6 Test Sections

Verify and Service Mode tests and services are divided into three sections according to their purpose, as follows:

- Functional tests
- Exerciser tests
- Utility tests

A.6.1 Functional Tests

Functional tests examine each device as though it existed in a standalone environment. Functional tests obtain complete operational testing of a device and identify faulty FRUs. Functional tests always indicate whether a device passed or failed testing and indicates the FRU associated with the failed device.

A.6.2 Exerciser Tests

Exerciser tests test each device for interaction with other devices. Several tests are run on all Q22-bus devices at the same time to simulate a busy system with heavy bus activity. Exerciser tests identify causes of intermittent system failures.

A.6.3 Utility Test

The utility test allows you to read the MyLongAddress (MLA) network address.

A.7 MDM Verify Mode Test Specifications

MDM Verify Mode tests are device tests designed for untrained personnel. They prohibit operator intervention during testing, except for installing loopbacks or cables. Verify Mode tests are listed in Table A-1.

Table A-1: MDM Diagnostics Verify Mode Tests

Test	Description of Test
Functional	
Test 1	DEFQA DAL bus test
Test 2	DEFQA states test
Test 3	DEFQA Interrupt test
Test 4	DEFQA queues test
Test 5	DEFQA DMA test
Exerciser	
Test 1	DEFQA DMA test
Utility	
Test 1	Read MLA utility

A.8 MDM Field Service Functional Test

Field service functional tests are designed for operators experienced in testing and debugging equipment. The operator may be asked to make minor physical alterations, including mounting an external loopback connector.

This diagnostic has one field service test, FIELD_TEST, which uses an external loopback (Digital part number 12-32005-01) to test the bulkhead loopback connector or the controller-cable-transceiver loop. (Internal loopback is tested in the MODE routines.)

FIELD_TEST TEST1 sends packets (using external loopback mode) and tests the bulkhead loopback interface logic.

A.9 MDM Field Service Exerciser Test

The exerciser is designed to stress the system, creating a simulation of normal system operation. By executing several exercisers together, on the same system, any margins in the system design and operation should be isolated so that it can be corrected. The exerciser does not require the operator to modify the system.

EXERCISER TEST performs the setup test that includes testing the internal loopback, testing the internal extended loopback, and testing the allocation of buffers.

FDDI Connector Keying and Optical Bypass Information

This appendix describes DEC FDDI controller/Q-bus multimode connectors and the optical bypass switch requirements.

B.1 FDDI Multimode Connector Keying

The MIC connectors are designed to align the fiber cable properly with the transmit and receive optics – that is, they are keyed and must be aligned properly. The DEC FDDI controller/Q-bus ships with S-type keys installed. Other types are available that include MIC A and MIC B for DAS versions (see Figure B-1).

The position of the keyway on the MIC plug determines the type of receptacle to which it connects. All cable plugs fit into the MIC S receptacle. The other MIC plugs and receptacles (type A, B, and M) must match for proper installation.

Figure B-1: DEC FDDI controller/Q-bus MIC Receptacle Keying

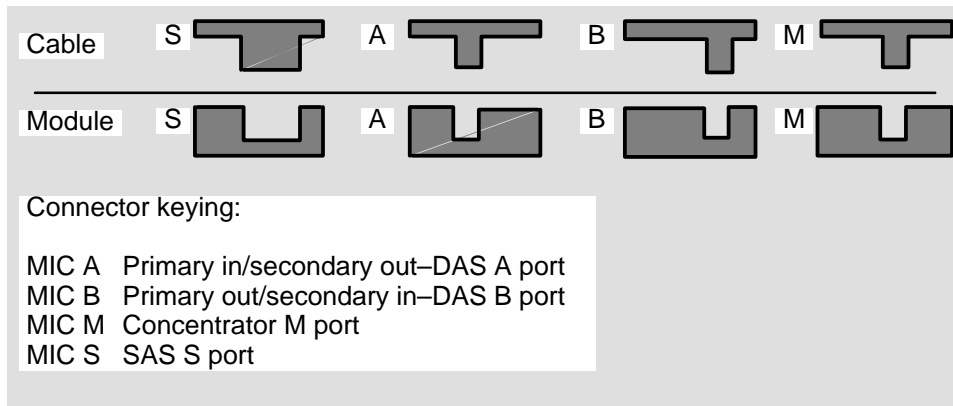

LKG-5072-90I

B.2 Changing the Connector Key

The DEC FDDIcontroller/Q-bus ships with a PHY S key installed (SAS and DAS). Optional PHY A, PHY B, and PHY M keys are included in the shipping package. The PHY connector key type is clearly marked on the top of each key.

If you want to change a key, refer to Figure B-2 and do the following:

1. Using a screwdriver, release the front edge of the PHY key.
2. Slide the key forward and remove it.
3. Tip the replacement key in place and press down.

Figure B-2: Changing a PHY Port Key

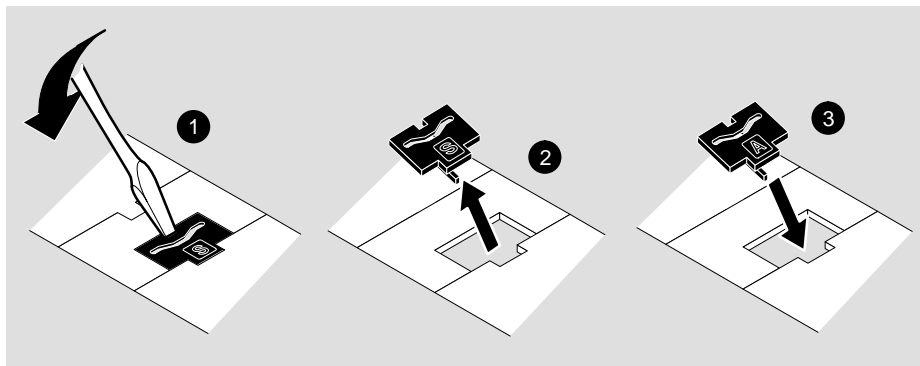

LKG-6937-92I

B.3 Optical Bypass Connector

The optical bypass relay feature on the controller maintains FDDI dual ring integrity if the controller breaks or is powered down. The optical bypass connector is available only on the DAS multimode versions. Figure B-3 shows the bypass connector and provides a description of the connector pins. Refer to this information when selecting optical bypass devices.

WARNING

To prevent personal injury or equipment damage, **do not** insert telecommunications cabling into the optical bypass relay connector.

Figure B-3: Optical Bypass Control Signals

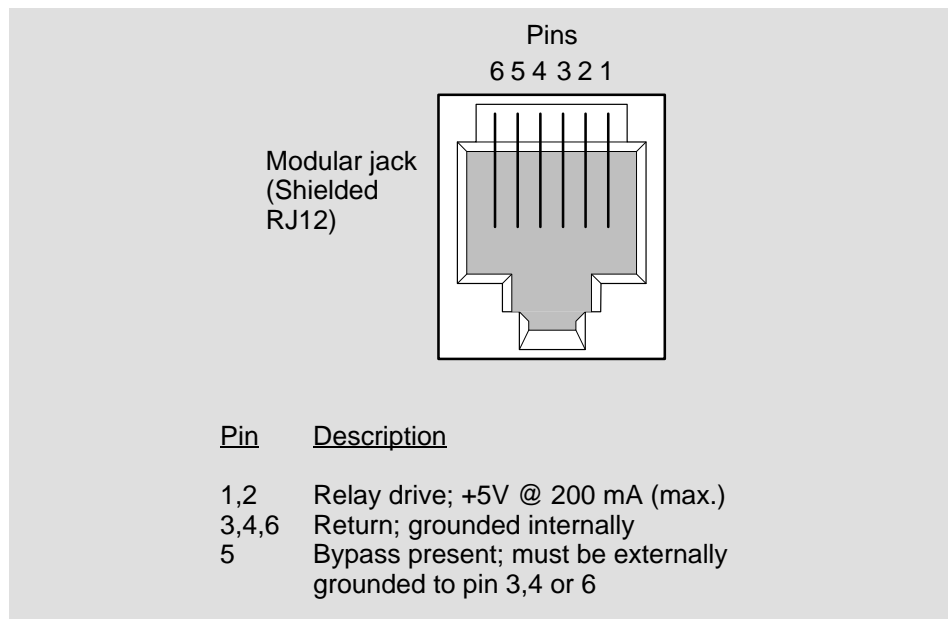

LKG-7996-931

C

Specifications

This appendix describes the power and environmental requirements for the DEC FDDIcontroller/Q-bus controller.

C.1 Power Requirements

Table C-1 defines the power requirements for the controller.

Table C-1: DEC FDDIcontroller/Q-bus Power Requirements

Module	+5 Volts (in Amps)	+12 Volts (in Amps)	Power (Watts)	ac Bus Loads (units/pf)	dc Bus Loads (units/ μ amps)
DAS	5.6 max.	0.1	33.5	4.2/30	1.5/150
SAS	5.12 max.	0.1	25.2	4.2/30	1.5/150

C.2 Environmental Requirements

Table C-2 defines the environmental requirements for the controller.

Table C-2: DEC FDDIcontroller/Q-bus Environmental Requirements

Item	Operating	Nonoperating
Temperature	0° C to 60° C (32° F to 140° F)	-40° C to 85° C (-40° F to 185° F)
Relative Humidity	10% to 90%	10% to 95%
Altitude	2.4 km (1.49 miles)	9.1 km (5.65 miles)

Related Documentation

Refer to the following documents for additional information related to the DEC FDDIcontroller/Q-bus and FDDI:

- *DECconcentrator 500 Installation* (Order No. EK-DEFCN-IN)
Explains how to install the DECconcentrator 500 unit and how to check its installation and operation. Also included are descriptions of the concentrator controls and indicators and examples of the concentrator installed in a network.
- *Fiber Distributed Data Interface System Level Description*
(Order No. EK-DFSLD-SD)
Describes the FDDI system, how it works, and the role of the individual components.
- *Fiber Distributed Data Interface Network Configuration Guidelines*
(Order No. EK-DFDDI-CG)
Describes how to configure an FDDI network. Also included are network configuration examples.

Index

C

- Commands
 - SHOW CONFIGURATION, 3-2, 3-3
 - SYSGEN, 3-2
- Configuring the system, 3-3
- Connector, FDDI multimode, 4-8
- Connector keying, B-1
 - changing, B-2
- Controller models, 1-2
- CSR address, 3-4
- CSR bits, 3-4

D

- DEC FDDI controller/Q-bus
 - component locations, 1-2
 - connectors and LEDs, 1-3
 - in a network configuration, 1-1

F

- FDDI cable
 - dressing the, 4-8
 - procedure for connecting the, 4-6

G

- Gap-filler, procedure for installing the, 4-4

H

- Hardware problems, solving, 5-4

I

- Installation
 - preparing the system for, 4-1
 - procedure for installing the controller, 4-3
 - verifying the, 4-10
 - verifying the communications connection, 4-10

L

- LEDs
 - FRU display and states, 5-2
 - PHY display and states, 5-2

M

- MicroVAX Diagnostic Monitor (MDM), A-1

O

Optical bypass connector, B-3
Overview, 1-1

R

Related documentation, D-1
Running SYSGEN, 3-2

S

Self-test, running, 5-1

Shipping package, contents, 2-2

Specifications, C-1

environmental requirements, C-1

power requirements, C-1

Switches

example of setting, 3-5

setting, 3-4

System Configuration, determining the,
3-2

T

Troubleshooting, basic, 5-1

HOW TO ORDER ADDITIONAL DOCUMENTATION

DIRECT TELEPHONE ORDERS

In Continental USA
call 1-800-DIGITAL
(1-800-344-4825)

In Canada
call 800-267-6215

In New Hampshire,
Alaska or Hawaii
call 603-884-6660

ELECTRONIC ORDERS (U.S. ONLY)

Dial 800-dec-demo with any VT100 or VT200
compatible terminal and a 1200 baud modem.

If you need assistance, call 1-800-DIGITAL (1-800-344-4825)

DIRECT MAIL ORDERS (U.S. and Puerto Rico*)

DIGITAL EQUIPMENT CORPORATION
P.O. Box CS2008
Nashua, New Hampshire 03061

DIRECT MAIL ORDERS (Canada)

DIGITAL EQUIPMENT OF CANADA LTD.
940 Belfast Road
Ottawa, Ontario, Canada K1G 4C2
Attn: A&SG Business Manager

INTERNATIONAL

DIGITAL EQUIPMENT CORPORATION
A&SG Business Manager
c/o Digital's local subsidiary
or approved distributor

Internal orders should be placed through Publishing and Circulation Services (P&CS),
Digital Equipment Corporation, 444 Whitney Street, NRO2, Northboro, Massachusetts 01532-2597

*Any prepaid order from Puerto Rico must be placed
with the Local Digital Subsidiary:
809-754-7575

DO NOT CUT – FOLD HERE AND TAPE



NO POSTAGE
NECESSARY
IF MAILED
IN THE
UNITED STATES

BUSINESS REPLY LABEL

FIRST CLASS PERMIT NO. 33 MAYNARD MASS.

POSTAGE WILL BE PAID BY ADDRESSEE

digital[™]

**Telecommunications and
Networks Publications**
550 King Street
Littleton, MA 01460–1289

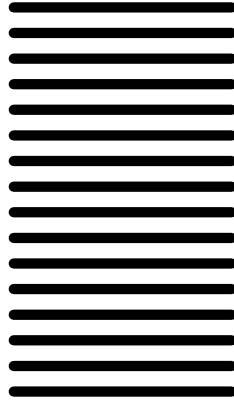

DO NOT CUT – FOLD HERE

Please return this card.

Your comments and suggestions will help us improve the quality and usefulness of our documentation.

Did you use the manual as a reference or as a step by step procedure to install the device?

Were the instructions easy to follow? _____

Were the instructions complete? _____

Were they in the proper sequence? _____

Which chapters or sections were most helpful? _____

Did you use the appendices? Which ones? _____

Were the illustrations helpful? _____ All? _____ Some? _____ Which ones? _____

Were some illustrations unnecessary? _____ Which ones? _____

Do you think the manual needs more illustrations? _____ Please give an example. _____

Thank you.

Name _____ Date _____

Title _____ Department _____

Organization _____ Street _____

City _____ State/Country _____ Zip Code _____

digital™

Printed in U.S.A.