

DEC FDDIcontroller/EISA



Installation

Order Number: EK-DEFEA-IN. B01

NOTICE – Class B Computing Device:

This equipment has been tested and found to comply with the limits for a Class B digital device, pursuant to Part 15 of the FCC rules. These limits are designed to provide reasonable protection against harmful interference in a residential installation. Any changes or modifications made to this equipment may void the user's authority to operate this equipment. This equipment generates, uses, and can radiate radio frequency energy and, if not installed and used in accordance with the instructions, may cause harmful interference to radio communications. However, there is no guarantee that interference will not occur in a particular installation. If this equipment does cause harmful interference to radio or television reception, which can be determined by turning the equipment off and on, you should try to correct the interference by one or more of the following measures:

- Reorient or relocate the receiving antenna.
- Increase the separation between the equipment and receiver.
- Connect the equipment into an outlet on a circuit different from that to which the receiver is connected.
- Consult the dealer or an experienced radio/TV technician for help.

FCC ID: A09-FDDI-S1 (Optical SAS version)
FCC ID: A09-FDDI-D1 (Optical DAS version)
FCC ID: A09-FDDI-U1 (UTP version)

This device complies with Part 15 of the FCC Rules. Operation is subject to the following conditions: (1) this device may not cause harmful interference, and (2) this device must accept any interference received, including interference that may cause undesired operation.

This equipment is in the second Class category (information equipment to be used in a residential area or an adjacent area thereto) and conforms to the standards set by the Voluntary Control Council for Interference by Data Processing Equipment and Electronic Office Machines aimed at preventing radio interference in such residential area.

When used near a radio or TV receiver, it may become the cause of radio interference.
Read the instructions for correct handling.

DEC FDDIcontroller/EISA

Installation

February 1994

This manual describes how to install and verify the operation of the DEC FDDIcontroller/EISA.

Supersession/Update Information: This is a revised manual.



Order Number: EK-DEFEA-IN. B01

The information in this document is subject to change without notice and should not be construed as a commitment by Digital Equipment Corporation. Digital Equipment Corporation assumes no responsibility for any errors that may appear in this document.

Copyright © 1993, 1994 by Digital Equipment Corporation
All Rights Reserved.
Printed in U.S.A.

The following are trademarks of Digital Equipment Corporation: DEC, DECconcentrator, DECconnect, DECnet, Digital, PATHWORKS, ThinWire, VMS, and the DIGITAL logo.

AT, IBM and OS/2 are registered trademarks of International Business Machines Corporation.

NetWare and Novell are registered trademarks of Novell, Incorporated.

SCO is a registered trademark of The Santa Cruz Operation, Incorporated.

UNIX is a registered trademark of UNIX System Laboratories, Inc., a wholly owned subsidiary of Novell, Incorporated.

Windows is a trademark and Microsoft, MS-DOS, and Windows NT are registered trademarks of Microsoft Corporation.

All other trademarks are the property of their respective owners.

Contents

Safety

Preface

1 Introduction

1.1	Fiber-Optic SAS Controller (DEFEA-AA)	1-4
1.2	UTP SAS Controller (DEFEA-UA)	1-5
1.3	Fiber-Optic DAS Controller (DEFEA-DA)	1-6
1.4	LED Descriptions	1-7
1.5	Software Description	1-9
1.6	Distribution Diskettes	1-9

2 Installation

2.1	Checking Package Contents	2-2
2.2	Preparing to Install the Controller	2-4
2.3	Verifying System and Software Requirements	2-4
2.3.1	DOS Requirements	2-5
2.3.2	SCO UNIX Requirements	2-5

2.4	Configuring the Controller	2-6
2.5	Installing the Controller	2-8
2.5.1	Fiber-Optic SAS Controller (DEFEA-AA) . .	2-11
2.5.2	UTP SAS Controller (DEFEA-UA)	2-12
2.5.3	Fiber-Optic DAS Controller (DEFEA-DA) . .	2-13
2.6	Verifying the Installation	2-14
2.7	Installing Drivers from the DOS-Format Distribution Diskette	2-15
2.7.1	Installing the DOS NDIS 2.01 Driver	2-15
2.7.2	Installing the OS/2 NDIS 2.01 Driver	2-16
2.7.3	Installing the Windows NT Driver	2-17
2.7.4	Installing Novell NetWare Drivers	2-18
2.7.5	Loading and Viewing the DOS-Format Diskette	2-22
2.8	Installing the SCO UNIX Driver	2-23
2.9	Connecting to the Network	2-24
2.9.1	Fiber-Optic SAS or DAS Controllers	2-25
2.9.2	UTP SAS Controller	2-26
2.10	Verifying the Controller Operation on the Network	2-27

3 Problem Solving

3.1	Isolating Controller, Driver Configuration, and Installation Faults	3-2
3.2	Diagnosing Problems with a Previously Operational Controller	3-2
3.2.1	Normal Powerup	3-3
3.2.2	Problem-Solving Tips	3-3
3.2.3	Problem-Solving Tools	3-3
3.3	Isolating Network Connection Faults	3-6
3.4	Isolating Network Interconnect Faults	3-9

3.5	Running Self-Test	3-10
3.6	Running INSTVER Diagnostics	3-10
3.7	Using the Digital Local Management Application (DEClma)	3-11

A Configurations and Specifications

A.1	Physical Description	A-1
A.2	Controller Configurations	A-2
A.3	Specifications	A-4

B Optical Bypass and FDDI Connectors

B.1	Optical Bypass Relay (OBR) RJ-12 Connector . .	B-1
B.2	FDDI Connector Keying	B-2
B.3	Installing Optional PHY Port Key	B-4

C Accessing MIBs and RFCs

C.1	Using Electronic Mail	C-1
C.2	Using ftpmail	C-2
C.3	Using Anonymous ftp	C-4
C.4	Obtaining a Diskette	C-5

Index

Figures

1-1	SAS/DAS Controllers Configured in an FDDI Network	1-3
-----	--	-----

1-2	Fiber-Optic SAS Controller (DEFEA-AA)	1-4
1-3	UTP SAS Controller (DEFEA-UA)	1-5
1-4	Fiber-Optic DAS controller (DEFEA-DA)	1-6
1-5	DOS-Format Distribution Diskette (Example)	1-11
2-1	Contents of Shipping Package	2-3
2-2	Removing the Option Slot Cover	2-9
2-3	Installing the Fiber-Optic SAS Controller (DEFEA-AA)	2-11
2-4	Installing the UTP SAS Controller (DEFEA-UA)	2-12
2-5	Installing the Fiber-Optic DAS Controller (DEFEA-DA)	2-13
2-6	Connecting the FDDI Cable to Fiber-Optic SAS or DAS Controllers (DAS Model Shown)	2-25
2-7	Connecting the FDDI Cable to the UTP SAS Controller	2-26
B-1	RJ-12 (OBR) Pin Assignments	B-2
B-2	Media Interface Connector Keying	B-3
B-3	Changing the PHY Port Key	B-4

Tables

1-1	Controller Models	1-1
1-2	LED States	1-7
2-1	Configuration Files	2-7
3-1	Isolating Controller and Driver Configuration and Installation Faults	3-4
3-2	Isolating Network Connection Faults	3-6
3-3	Isolating Network Interconnect Faults	3-9
A-1	Memory Address Range Selections	A-3
A-2	Operating Environment and Power Requirements	A-4

Safety

Any warning or caution that appears in this manual is defined as follows:

Warning  Contains information to prevent personal injury.

Caution  Contains information to prevent damage to equipment.

Vorsicht Enthält Informationen, die beachtet werden müssen, um den Benutzer vor Schaden zu bewahren.

Achtung Enthält Informationen, die beachtet werden müssen, um die Geräte vor Schaden zu bewahren.

Danger Signale les informations destinées à prévenir les accidents corporels.

Attention Signale les informations destinées à prévenir la détérioration du matériel.

Aviso Contiene información para evitar daños personales.

Precaución Contiene información para evitar daños al equipo.

The cautions you must observe for the hardware described in this manual are listed below in English, German, French, and Spanish. The pages on which these safety messages appear are also listed.

CAUTION 

Static electricity can damage modules and electronic components. Digital recommends using a grounded antistatic wrist strap and a grounded work surface when handling any modules. (Pages 2-2, 2-4, and 2-8)

ACHTUNG

Module und elektronische Komponenten können durch elektrostatische Entladungen beschädigt werden. Benutzen Sie immer eine antistatische Gelenkmanschette und eine geerdete Arbeitsunterlage, wenn Sie am offenen Gerät arbeiten.

ATTENTION

Les charges excessives d'électricité statique peuvent endommager les modules et les composants électroniques. Digital conseille l'utilisation d'un bracelet de masse et d'un plan de travail mis à la terre lors de la manipulation des modules.

PRECAUCIÓN

La electricidad estática puede dañar los componentes electrónicos y los módulos. Digital recomienda que se utilicen cintas de pasadores y superficies de trabajo conectadas a tierra al trabajar con cualquier módulo.

WARNING 

Some fiber-optic equipment can emit laser light that can injure your eyes. Never look into an optical fiber or connector port. Always assume the cable is connected to a light source. (Page 2–24)

VORSICHT

Schauen Sie niemals direkt in ein Glasfaserkabel oder einen Glasfaseranschluß. Die Laserstrahlen in faser-optischen Geräten können Augenverletzungen verursachen.

DANGER

Certains équipements utilisant les fibres optiques peuvent émettre des rayonnement laser dangereux pour les yeux. Ne vous avisez jamais de regarder par l'extrémité d'une fibre optique ou dans l'ouverture d'un connecteur. Considérez toujours que le câble est relié à une source lumineuse.

AVISO

Algunos equipos de fibra óptica pueden emitir luz láser que daña los ojos. No se debe mirar en una puerta de conector o fibra óptica. Siempre se debe suponer que el cable está conectado a la luz.

CAUTION 

When adding any option module to your computer, verify that the combined power (wattage) required for all modules in your computer does not exceed the power supply rating. Check your computer documentation for this information. (Page A-4)

ACHTUNG

Wenn Sie Zusatzmodule in Ihren Computer einbauen, darf die gemeinsame Leistung (in Watt) aller eingebauten Module die Nennleistung nicht überschreiten. Weitere Informationen finden Sie in der Dokumentation zu Ihrem Computer.

ATTENTION

Si vous ajoutez des options à votre système, assurez-vous que le nombre de watts total n'excède pas la puissance nominale du bloc d'alimentation. Reportez-vous à la documentation de votre système pour obtenir plus d'information.

PRECAUCIÓN

Al añadir cualquier módulo de opciones al ordenador, es preciso comprobar que la potencia combinada (vatios) necesaria para todos los módulos del ordenador no sobrepasa las condiciones normales del suministro de energía. Consúltense estos datos en la documentación del ordenador.

WARNING 

To prevent personal injury or equipment damage, **do not** insert telecommunications cabling into the optical bypass relay connector. (Pages 1–7 and B–1)

VORSICHT

Um Personen oder Geräteschäden zu vermeiden, dürfen Sie das Telefonkabel **AUF KEINEN FALL** am Anschluß des optischen Bypass-Relais anschließen.

DANGER

Pour éviter tout risque d'accident corporel ou de dommage matériel, **NE BRANCHEZ PAS** de câble de télécommunication sur le connecteur de relais sélectif optique (optical bypass relay connector).

AVISO

Para evitar daños personales o al equipo, **NO** se debe introducir cableado de telecomunicaciones en el conector óptico de relés de derivación.

Preface

This manual describes how to install the DEC FDDIcontroller/EISA into a 32-bit EISA-compatible computer, and how to connect it to an FDDI network.

Intended Audience

This manual assumes that you are familiar with computers and understand the concepts and uses of FDDI networks. To install this product, you must be familiar with your computer's EISA configuration utility.

Related Documents

Additional information relative to the DEC FDDIcontroller/EISA and Fiber Distributed Data Interface (FDDI) networks can be found in the following documents:

- *DECconcentrator 500 Installation* (Order No. EK-DEFCN-IN)

This manual describes how to configure and install the DECconcentrator 500 unit and how to verify its operation.

- *DECconcentrator 900MX Installation*
(Order No. EK-DEF6X-IN)

Describes how to install and configure the DECconcentrator 900MX.

- *Fiber Distributed Data Interface System Level Description* (Order No. EK-DFSLED-SD)

Describes the FDDI system, how it works, and the role of the individual components.
- *Fiber Distributed Data Interface Network Configuration Guidelines* (Order No. EK-DFDDI-CG)

This manual describes the guidelines for connecting devices to an FDDI network. It also includes network configuration examples.
- *A Primer on FDDI: Fiber Distributed Data Interface* (Order No. EC-H1580-42/92 07), Version 2.0

This manual describes the features, topologies, and components of the FDDI local area network (LAN) standard.
- *X3.166-1990 Physical Media Dependent for Multimode Fiber*, American National Standards Institute (ANSI)

This specification defines the Physical Layer Medium Dependent (PMD) sublayer. This sublayer corresponds to the lower portion of the Physical layer of the OSI seven-layer model. This standard provides the specifications for the optical transmitter and receiver used by FDDI, the power levels, allowable bit error rates, fiber-optic transmission wavelength, fiber-optic cable, and connectors.

Conventions Used in This Manual

This manual uses the following conventions:

<code>Special type</code>	Indicates a literal example of system output.
bold	In interactive examples, bold type indicates text that you must enter exactly as shown. In text, bold type indicates a command, directory name, or file name.
lowercase	When a command appears in lowercase, enter it exactly as shown. In an example, enter the characters in lowercase.
<i>Key</i>	Indicates that you press the specified key. For example, Return means that you should press the Return key.

The postage-paid Reader's Comments form at the back of this document requests your critical evaluation to assist us in preparing future documentation.

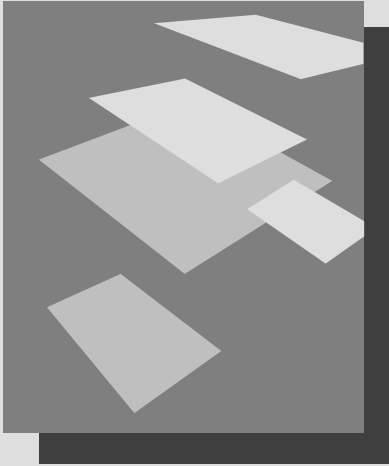

Introduction

Fiber-Optic SAS Controller (DEFEA-AA)

UTP SAS Controller (DEFEA-UA)

Fiber-Optic DAS Controller (DEFEA-DA)

LED Descriptions

Software Description

Distribution Diskettes

Introduction

The DEC FDDI controller/EISA (hereafter called the controller) provides direct connection of industry-standard computers with an EISA (Extended Industry Standard Architecture) bus to a 100-megabits/second FDDI network. Drivers for supported operating systems provide the configuration flexibility required in multivendor networks.

Table 1-1 lists and describes the EISA controller models available from Digital Equipment Corporation.

Table 1-1: Controller Models

Model	Description
DEFEA-AA	One-card, single attachment station (SAS) controller with multimode optics and ANSI MIC connectors
DEFEA-UA	One-card, single attachment station (SAS) controller with shielded RJ-45 modular connector. Accepts Category 5 unshielded twisted-pair (UTP) or Category 5 sheath-shielded, 100-ohm twisted-pair (TP) cable with TP-MIC plug
DEFEA-DA	Two-card, dual attachment station (DAS) controller with multimode optics and ANSI MIC connectors

SAS controllers connect to the FDDI network through an FDDI-compliant concentrator (DECconcentrator 900MX), using multimode fiber-optic cable (for model DEFEA-AA) or using Category 5 UTP copper cable (for model DEFEA-UA).

The fiber-optic DAS controllers (DEFEA-DA) connect directly to the FDDI ring through multimode fiber-optic cables.

NOTE

Copper Category 5 UTP and Category 5 sheath-shielded, 100-ohm TP cable comply with FDDI standards and interoperate with products that implement the American National Standards Institute (ANSI) Twisted Pair-Physical Medium Dependent (TP-PMD) standard.

Figure 1-1 shows an example of how a SAS- or DAS-configured, EISA-compatible computer interfaces to the FDDI network using fiber-optic or Category 5 TP cable.

Figure 1-1: SAS/DAS Controllers Configured in an FDDI Network

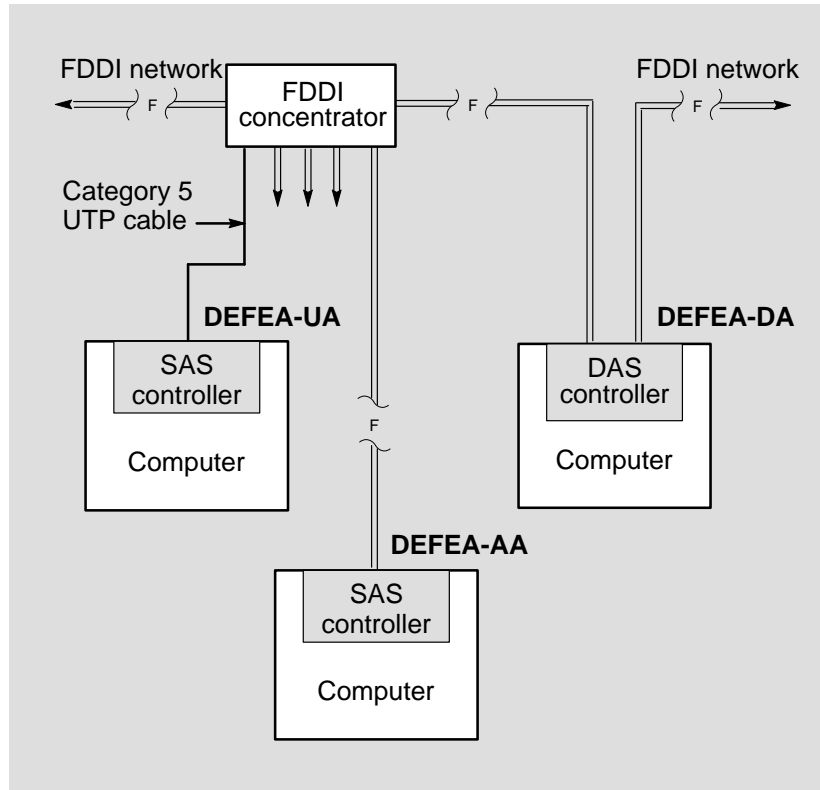

LKG-8905-941

1.1 Fiber-Optic SAS Controller (DEFEA-AA)

The fiber-optic SAS controller (Figure 1-2) consists of one card that plugs into the computer EISA bus. A single ANSI MIC connector is the interface to FDDI fiber-optic cable (from a concentrator such as the DECconcentrator 900MX).

The controller contains onboard diagnostics that execute when power is applied. A two-color (green or red) light-emitting diode (LED) on the controller mounting bracket indicates the operating status of the controller and its PHY port. Refer to Section 1.4 for a description of the controller LEDs.

Figure 1-2: Fiber-Optic SAS Controller (DEFEA-AA)

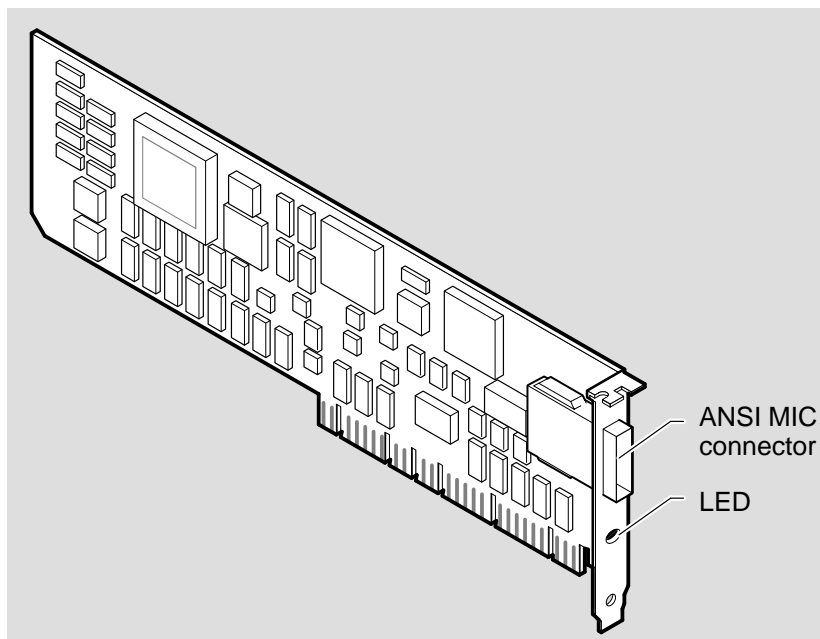

LKG-8906-941

1.2 UTP SAS Controller (DEFEA-UA)

The UTP SAS controller (Figure 1–3) consists of two cards: a parent card and an attached daughter card that is connected by a 40-pin connector. The parent card plugs into a single EISA bus slot.

The controller contains onboard diagnostics that execute when power is applied. A two-color (green or red) light-emitting diode (LED) on the controller mounting bracket indicates the operating status of the controller and its PHY port. Refer to Section 1.4 for a description of the controller LEDs.

Figure 1–3: UTP SAS Controller (DEFEA-UA)

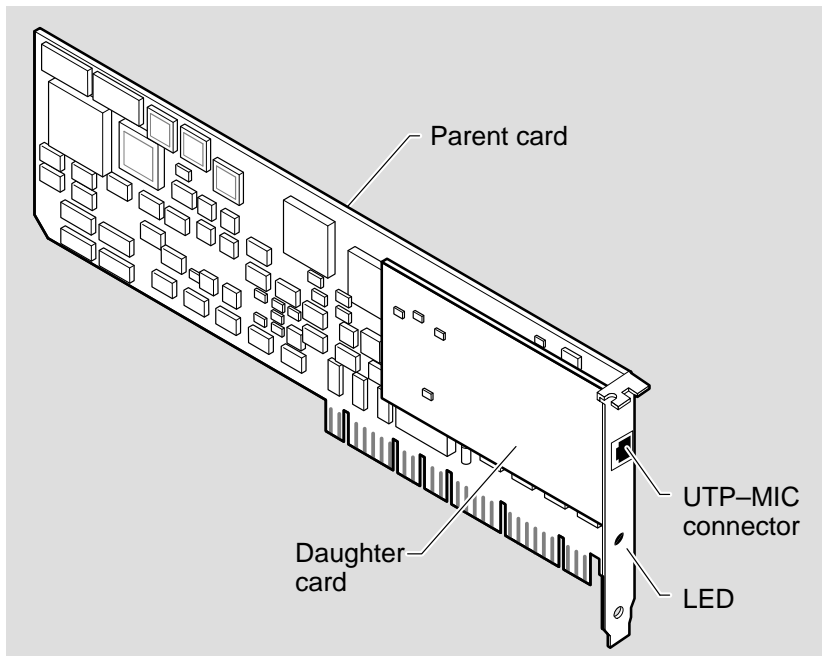

LKG-8913-941

1.3 Fiber-Optic DAS Controller (DEFEA-DA)

The fiber-optic DAS controller (Figure 1-4) consists of two cards: a parent card and a daughter card. The cards are connected by a ribbon cable and plug into adjacent computer slots on the EISA bus.

The controller contains onboard diagnostics that execute when power is applied. A two-color (green or red) light-emitting diode (LED) on the mounting bracket of each card indicates the operating status of the card and its PHY port. Refer to Section 1.4 for a description of the controller LEDs.

Figure 1-4: Fiber-Optic DAS Controller (DEFEA-DA)

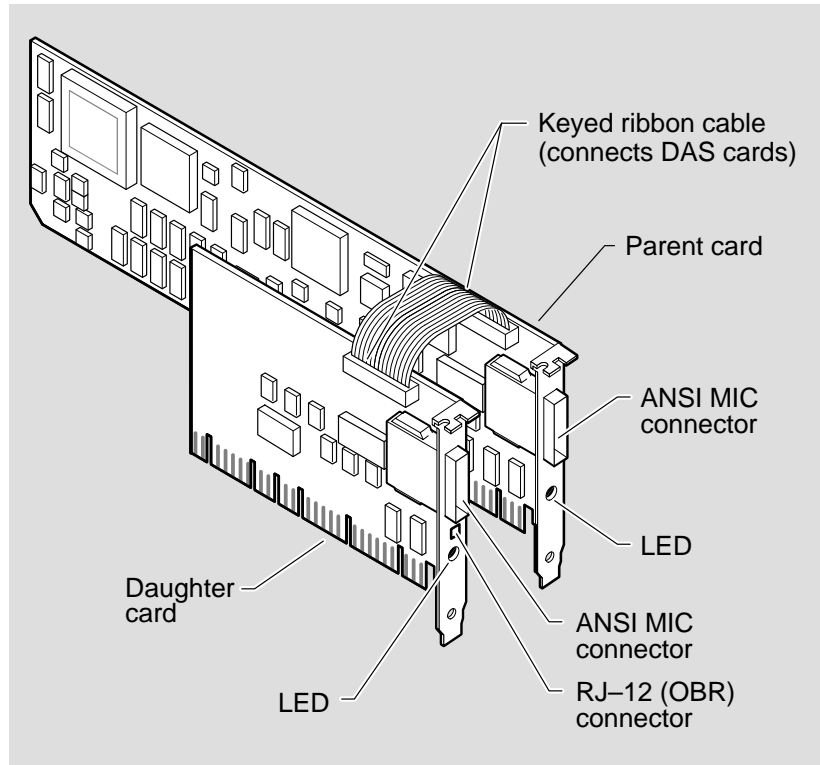

LKG-6863-941

An ANSI MIC connector on each card provides the FDDI DAS interface (directly to the FDDI ring).

The fiber-optic DAS controller daughter card contains an RJ-12 connector for inserting an optional optical bypass relay (OBR). This relay maintains connectivity of the FDDI ring in the absence of power or during fault conditions in the node.

WARNING 

To prevent personal injury or equipment damage, **do not** insert telecommunications cabling into the optical bypass relay connector.

Refer to Appendix B for more information on the OBR.

1.4 LED Descriptions

The controller LEDs are used to indicate the status of the controller and the FDDI port. The LEDs are visible on the controller's front panel (at the back of your computer).

Table 1–2 lists and describes possible LED states for all controller models.

Table 1–2: LED States

LED	Color	Normal	Description
PHY/PHY A	Green	On	On — PHY connection complete
	Green	Flashing	Flashing — PHY connection in progress (or no cable attached)
	Red		On — If on after system boots, indicates broken port or Link Confidence Test (LCT) failure; retry loop

Table 1–2 (Cont.): LED States

LED	Color	Normal	Description
(Continued)			If on before system boots, indicates self-test failure
	Red		Flashing — Illegal topology
	Green/Red	Alternating	Alternating — Standby mode when connected to a concentrator in a dual-homing configuration (DEFEA-DA only)
			Off — Port disabled via management or LED or controller broken
PHY B (DAS only)	Green	On	On — PHY connection complete
	Green	Flashing	Flashing — PHY connection in progress (or no cable attached)
	Red		On — If on after system boots, indicates broken port or Link Confidence Test (LCT) failure; retry loop
			If on before system boots, indicates self-test failure
	Red		Flashing — Illegal topology
			Off — Port disabled via management or LED or controller broken

1.5 Software Description

The software packages required to operate the controller on the network are:

- Operating system software

This is your system software, such as DOS, SCO UNIX, OS/2, or Windows NT.

- Network operating system software

This includes software such as Novell NetWare, Digital PATHWORKS, or Microsoft LAN Manager. This layered software provides the network services such as DECnet or TCP/IP (Transmission Control Protocol/Internet Protocol).

- Device driver software

For most operating environments, this software is part of the controller product package contained on the distribution diskettes (refer to Section 1.6). The device driver allows the network operating system software to communicate with the controller and must be installed as part of the installation procedure.

1.6 Distribution Diskettes

The distribution software comprises two (or more) diskettes: diskette 1 is for systems that use DOS-format diskettes and diskette 2 is for the SCO UNIX environment. Additional diskettes can be included in your shipment for product enhancements.

The contents of these diskettes are as follows:

- Diskette 1 is a DOS-format distribution diskette that contains the following information:

- A README.TXT file in the root directory that explains how to access files and has an overview of the diskette
- Subdirectories for each supported operating system with the software files to install and the driver installation procedures for that particular operating system
- EISA configuration files:
 - (A:\!DEC3001.CFG)
 - (A:\!DEC3002.CFG)
- System diagnostic INSTVER:
 - (A:\DIAG\INSTVER.EXE)
- A Digital Local Management Application (DEClma) executable file for some supported operating systems

NOTE

Software components will be added to diskette 1 throughout the product's life as new operating systems are supported. Refer to the README.TXT file in the root directory for the latest description of the diskette contents.

Figure 1-5 shows an example of the diskette 1 file structure.

- Diskette 2 is the SCO UNIX distribution diskette that contains the following information:
 - A rel_inst.notes file that explains how to install the DEC FDDIcontroller/EISA SCO UNIX software
 - The software files necessary to install the SCO LLI Driver software
 - A Digital Local Management Application (DEClma) executable file for running under SCO UNIX

Figure 1-5: DOS-Format Distribution Diskette (Example)

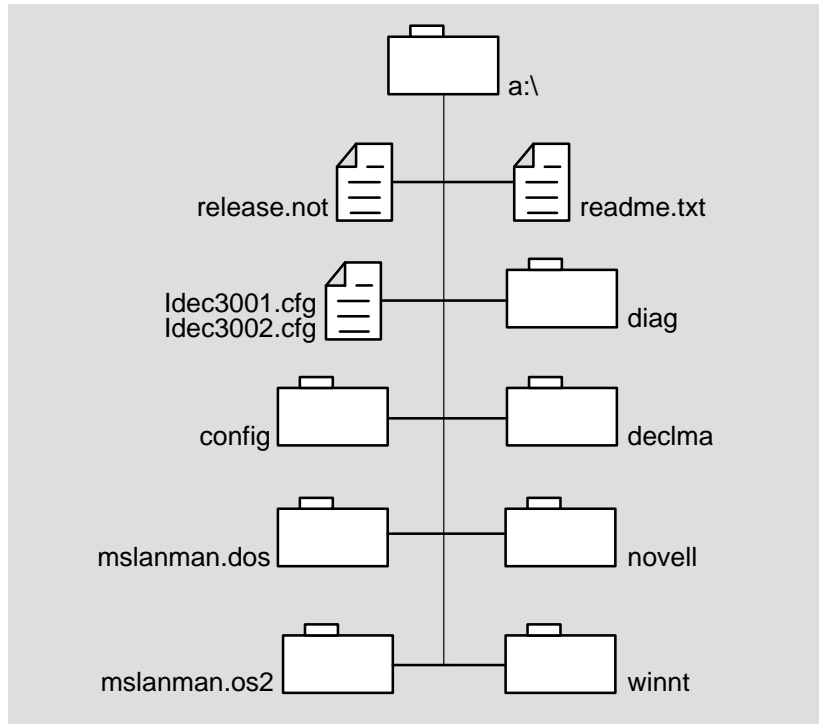

LKG-8914-941

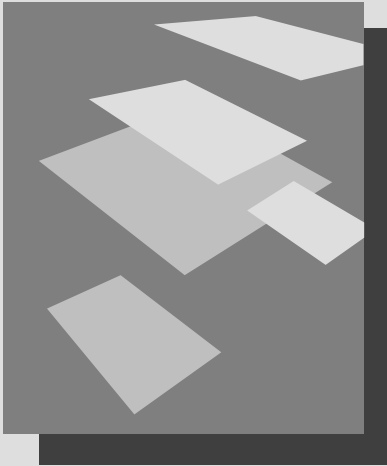

Installation

Checking Package Contents

Preparing to Install the Controller

Verifying System and Software Requirements

Configuring the Controller

Installing the Controller

Verifying the Installation

***Installing Drivers from the DOS-Format
Distribution Diskette***

Installing the SCO UNIX Driver

Connecting to the Network

Verifying the Controller Operation on the Network

Installation

This chapter describes how to install the controller into any 32-bit EISA bus-compatible computer and how to connect it to the network.

Installing your controller involves the following steps:

1. Printing and reading the `README.TXT` file in the root directory of diskette 1, and the `README.TXT` file for your operating environment. This file is located in the operating-system-specific subdirectory of the appropriate distribution diskette.
2. Verifying the system and software requirements.
3. Performing the EISA configuration procedure.
4. Installing the controller into the configured slot(s).
5. Installing the driver software.
6. Connecting to the network and verifying both the hardware and software installations.

2.1 Checking Package Contents

Check the contents of your shipment as follows:

CAUTION

Static electricity can damage modules and electronic components. Digital recommends using a grounded anti-static wrist strap and a grounded work surface when handling any modules.

1. Attach one end of the antistatic wrist strap to your wrist and the other end to an earth ground (\oplus).
2. Remove the contents from the box and place them nearby until you are ready to install the controller.
3. Check the shipment for damage and missing parts (see Figure 2-1).

NOTE

Figure 2-1 illustrates the contents of the SAS kits (DEFEA-AA and DEFEA-UA). The contents of the DAS kit (DEFEA-DA) is similar except that it has two cards and a ribbon cable.

The kit contains the following items (including this manual):

- The controller (packaged inside an antistatic bag)
- Two or more 3 1/2-inch, 1.44-MB diskettes:
 - Diskette 1: DOS-format distribution diskette
 - Diskette 2: Distribution diskette for SCO UNIX
 - Additional diskettes can be included for product enhancement (for example, a firmware upgrade diskette)

Notify your carrier immediately if there is any shipping damage. If the kit is incomplete, contact your Digital sales representative.

Figure 2-1: Contents of Shipping Package

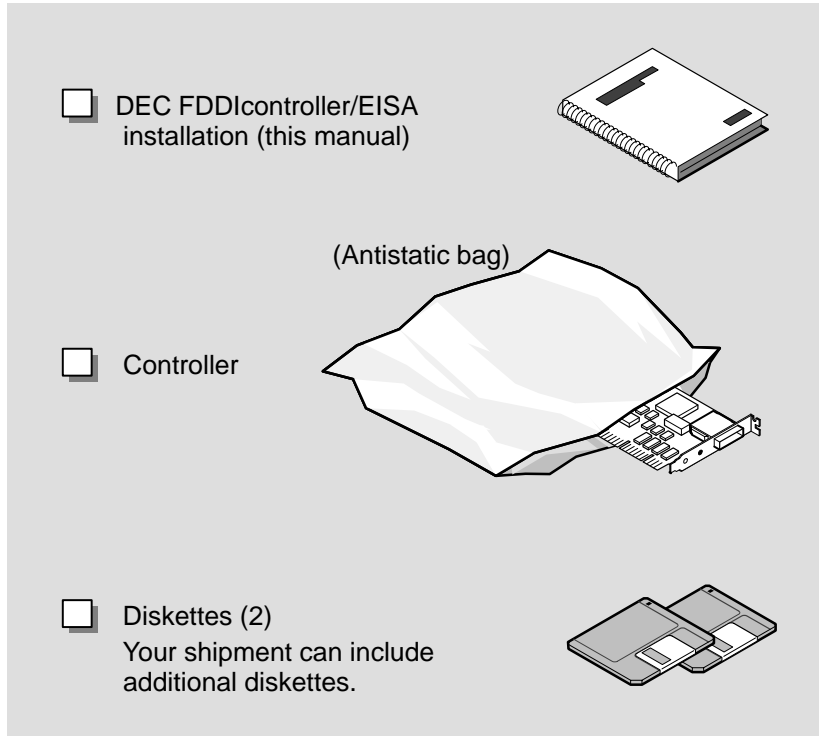

LKG-8915-941

2.2 Preparing to Install the Controller

You need the following network equipment and tools before you install and use the controller:

- EISA configuration utility for your system.
- Your computer system documentation.
- FDDI cables (Category 5 UTP or multimode fiber-optic cables) ready for connecting the computer to the network. See the *OPEN DECconnect Building Wiring Components and Applications Catalog* if you need additional information about cabling.
- An antistatic, grounding wrist strap. A wrist strap, ground wire, and table pad (not supplied) are available in Digital's field service kit (Part Number: 29-11762-00).

CAUTION

Static electricity can damage modules and electronic components. Digital recommends using a grounded anti-static wrist strap and a grounded work surface when handling any modules.

- A Phillips-head screwdriver and a flat-head screwdriver.

2.3 Verifying System and Software Requirements

The DOS and SCO UNIX requirements are listed separately in the following sections.

Configure the controller after you verify the requirements for your operating environment (refer to Section 2.4).

2.3.1 DOS Requirements

The following are system and software requirements for DOS computers.

- Computer operating system and network operating system compatibility. Refer to your system documentation for instructions on displaying your software version number.
- Adequate disk and DRAM memory space. Refer to your system documentation for instructions on verifying your system memory requirements.
- Identifying the FDDI frame type. Contact your network manager to identify the FDDI frame type selected for this network.

2.3.2 SCO UNIX Requirements

The following are system and software requirements for SCO UNIX computers:

- An account with superuser privileges.
- Computer operating system and network operating system compatibility. Refer to either your SCO UNIX documentation or the release notes file (`rel_inst.notes`) on diskette 2 for instructions on displaying your software version number.
- Network operating system software; for example, DECnet and TCP/IP.
- Adequate disk and DRAM memory space. Refer to your SCO UNIX documentation or the release notes file (`rel_inst.notes`) on diskette 2 for instructions on verifying your system memory requirements.

- DECnet node address or TCP/IP address. Contact your network manager. The address is necessary for verifying proper driver installation and connection to the network.

2.4 Configuring the Controller

To configure the controller into your computer system, perform the following steps:

NOTE

Do not install the controller until instructed.

1. Turn off power to your computer system before running the EISA configuration utility.
2. Determine whether you have any ISA hardware options (such as an ISA video controller) installed in the EISA slots of the system. Refer to your computer system documentation to determine the slots available for EISA options. If any ISA options are located in EISA slots, record the slot number, interrupt-request (IRQ) level, and memory address settings for each of these ISA options. For the IRQ level and memory address settings information, refer to your computer system documentation.

NOTE

The DEFEA-DA (DAS model) consists of two cards (parent card and daughter card) requiring two slots. The parent card must be installed into a bus master slot determined by the configuration utility. The daughter card can be installed into an adjacent slot on either side of the parent card.

3. Read your computer system documentation for information about using the EISA configuration utility to add a new hardware option to your system.

4. Insert the EISA configuration utility diskette (write-enabled) into the appropriate disk drive. This diskette is packaged with your computer.
5. Turn on the power to your computer system.
6. Follow your EISA configuration utility instructions to copy the configuration files (!DEC3001.CFG and !DEC3002.CFG) from diskette 1 to your EISA configuration utility diskette.

NOTE

There are two EISA configuration files provided for the controllers: !DEC3001.CFG and !DEC3002.CFG. The file you use to configure the system depends upon the part number of the controller you are installing. The controller's part number is marked on a label attached to the controller.

7. Determine which configuration file you need to use (see Table 2-1).

Table 2-1: Configuration Files

Controller Part Number	Use Configuration File . . .
54-21497-0X	!DEC3001.CFG
54-21503-0X	!DEC3002.CFG

8. Configure the system. This process adds the configuration file information to the system configuration file.
9. Examine the slot number, memory address, and IRQ settings for the controller. You may need to adjust these settings to avoid conflicts with the settings of other hardware options in your system.
10. Record the slot number, memory address, and IRQ settings for future reference.

Appendix A contains more information regarding memory-address and interrupt-request selections.

NOTE

For the DEFEA-DA (DAS model), the EISA configuration settings pertain to the parent card only. **Do not** add the daughter card settings to the EISA configuration system file.

11. Save the new configuration data, then exit the utility.

For some configuration utilities, you must examine system and new hardware option switch settings before you save the configuration data and exit the utility. The controller has no switches or jumpers. Follow your EISA configuration utility instructions before you exit the utility.

12. When the configuration utility indicates it is safe to do so, turn off the power to your computer system and install the controller (refer to Section 2.5).

2.5 Installing the Controller

This section explains how to install a SAS or DAS controller into an EISA-based computer.

CAUTION

Static electricity can damage modules and electronic components. Digital recommends using a grounded anti-static wrist strap and a grounded work surface when handling any modules.

To install the controller, complete the following steps:

1. Remove any diskette(s) from the computer's disk drive(s).
2. Turn off the power to your computer.

6. Remove the controller (and daughter card, if applicable) from the protective bag. Remove the optical dust cap(s) from any ANSI MIC connectors (fiber-optic models only).
7. Install the controller:
 - a. To install the fiber-optic SAS controller (DEFEA-AA), go to Section 2.5.1.
 - b. To install the UTP SAS controller (DEFEA-UA), go to Section 2.5.2.
 - c. To install the fiber-optic DAS controller (DEFEA-DA), go to Section 2.5.3.

2.5.1 Fiber-Optic SAS Controller (DEFEA-AA)

1. Install the controller into the appropriate option slot and secure it with the option slot cover screw (see Figure 2-3).
2. Replace the computer cover.
3. Go to Section 2.6 to verify the installation.

Figure 2-3: Installing the Fiber-Optic SAS Controller (DEFEA-AA)

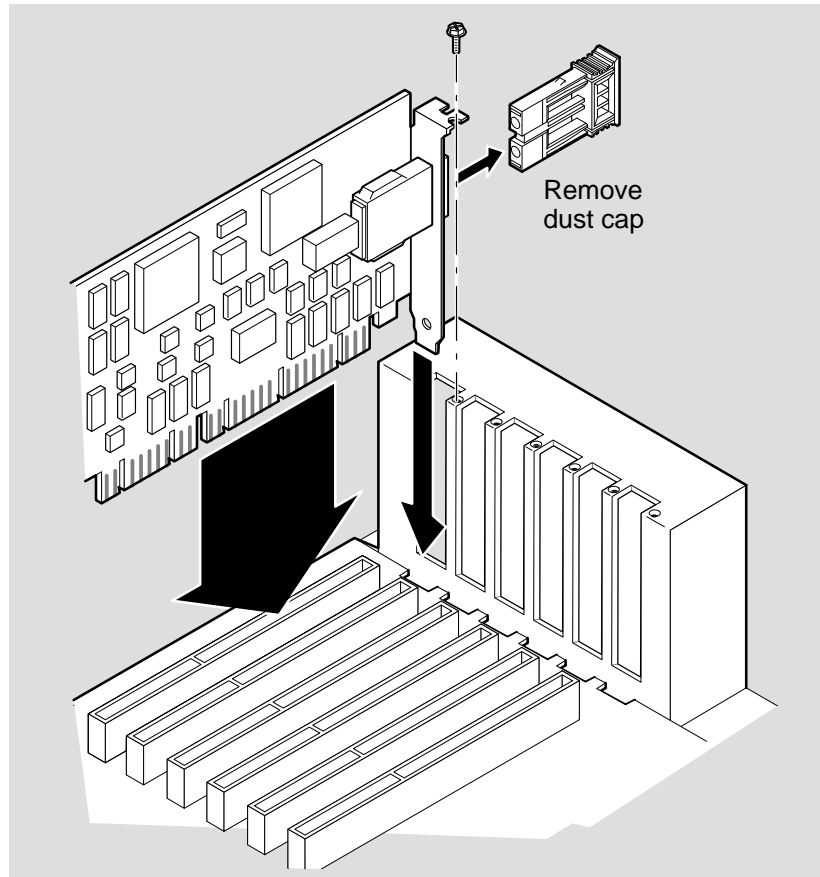

LKG-8908-941

2.5.2 UTP SAS Controller (DEFEA-UA)

1. Install the controller into the appropriate option slot and secure it with the option slot cover screw (see Figure 2-4).
2. Replace the computer cover.
3. Go to Section 2.6 to verify the installation.

Figure 2-4: Installing the UTP SAS Controller (DEFEA-UA)

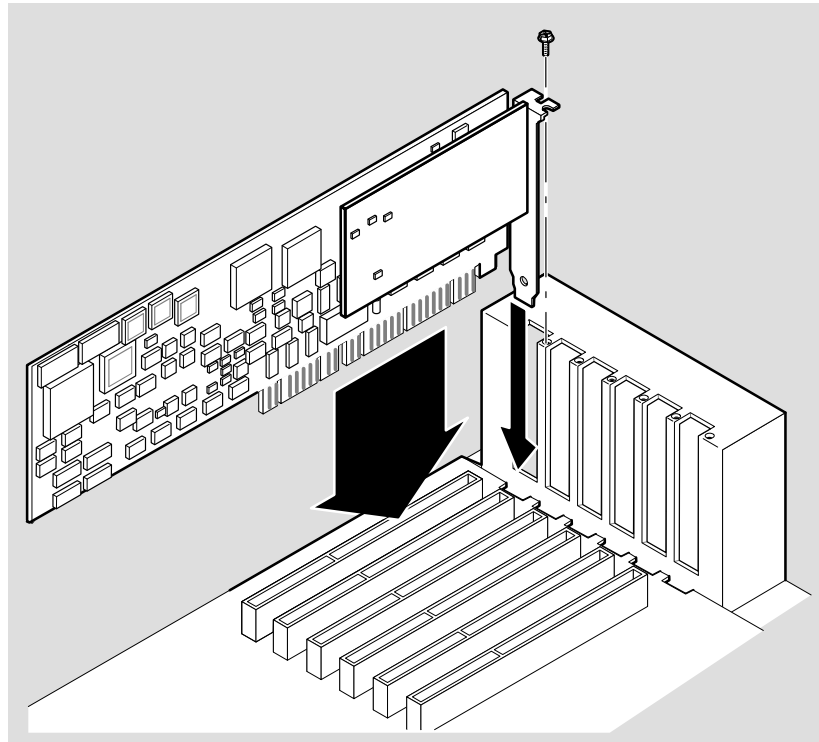

LKG-8909-941

2.5.3 Fiber-Optic DAS Controller (DEFEA-DA)

1. Install the controller and daughter card into the appropriate option slots and secure them using the screws that held the option slot covers (see Figure 2-5).
2. Connect the ribbon cable. Note that the ribbon cable connectors are keyed and can be installed in only one position.
3. Replace the computer cover.
4. Go to Section 2.6 to verify the installation.

Figure 2-5: Installing the Fiber-Optic DAS Controller (DEFEA-DA)

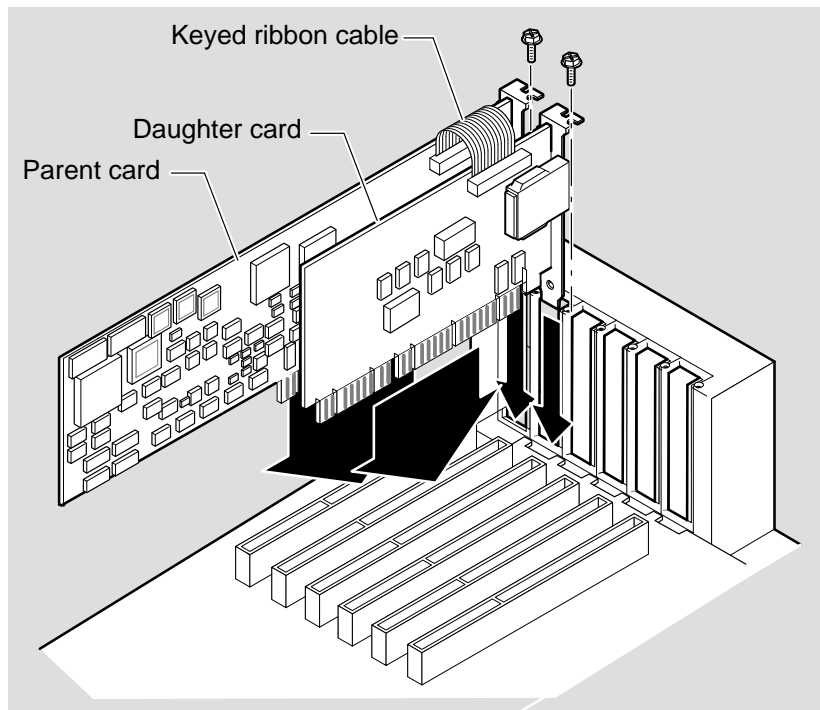

LKG-8910-94I

2.6 Verifying the Installation

Complete the following steps to verify that the controller(s) are installed and operating properly in your computer:

1. Turn on power to the computer and observe the controller LED(s).
2. Note the following events (within 10 seconds after the computer power is turned on):
 - a. The controller LED on the mounting bracket flashes green (three flashes) for approximately 1 second.
 - b. When the controller passes the powerup self-test, the LED turns off.

A steady red LED indicates a powerup self-test failure.

NOTE

For the DAS model, the LED on each card indicates the status of the card port, and a steady red indication on the DAS daughter card indicates a possible failure with that card.

If you observe any indication other than a successful self-test, turn off power to the computer, reseal the installed controller card(s), then repeat step 1.

If the self-test fails repeatedly, refer to Table 3-1 for problem solving information.

You are now ready to install your device driver:

- To install device drivers from diskette 1, the DOS-format distribution diskette, go to Section 2.7.
- To install the SCO UNIX device driver, go to Section 2.8.

2.7 Installing Drivers from the DOS-Format Distribution Diskette

This section explains how to install the following device drivers from the DOS-format distribution diskette:

- DOS NDIS 2.01 driver
- OS/2 NDIS 2.01 driver
- Windows NT drivers
- Novell NetWare drivers and software

2.7.1 Installing the DOS NDIS 2.01 Driver

The DOS-format distribution diskette (diskette 1) contains the driver and software for using your controller in a DOS system.

NOTE

Refer to Section 2.7.5 if you need instructions on loading and viewing the DOS-format distribution diskette.

To install the DOS NDIS 2.01 driver, do the following:

1. Follow the procedures described in your operating system documentation for installing an unlisted network adapter driver.
2. From the DOS prompt, locate and view the A:\README.TXT file on the DOS-format distribution diskette. The README.TXT file contains the location of the DOS NDIS 2.01 README.TXT file.
3. Refer to the DOS NDIS 2.01 README.TXT file for more specific installation information. Use this information along with your operating system documentation to install the device driver for your controller.

After you install the driver, proceed to Section 2.9 to connect your system to the network.

2.7.2 Installing the OS/2 NDIS 2.01 Driver

The DOS-format distribution diskette (diskette 1) contains the driver and software for using your controller in an OS/2 system.

NOTE

Refer to Section 2.7.5 if you need instructions on loading and viewing the DOS-format distribution diskette.

To install the OS/2 NDIS 2.01 driver, do the following:

1. Follow the procedures described in your operating system documentation for installing an unlisted network adapter driver.
2. From the DOS prompt, locate and view the A:\README.TXT file on the DOS-format distribution diskette. The README.TXT file contains the location of the OS/2 NDIS 2.01 README.TXT file.
3. Refer to the OS/2 NDIS 2.01 README.TXT file for more specific installation information. Use this information along with your operating system documentation to install the device driver for your controller.

After you install the driver, proceed to Section 2.9 to connect your system to the network.

2.7.3 Installing the Windows NT Driver

The DOS-format distribution diskette (diskette 1) contains the driver and software for using your controller, under Windows NT, on a variety of hardware platforms.

NOTE

Refer to Section 2.7.5 if you need instructions on loading and viewing the DOS-format distribution diskette.

To install the Windows NT driver, do the following:

1. Follow the procedure that describes the installation of network controllers in your *Windows NT System Guide*.
2. From the DOS prompt, locate and view the A:\README.TXT file on the DOS-format distribution diskette. The README.TXT file contains the location of the Windows NT README.TXT file.
3. Refer to the Windows NT README.TXT file for more specific installation information. Use this information along with the instructions provided in your *Windows NT System Guide* to install the device driver for your controller.

After you install the driver, proceed to Section 2.9 to connect your system to the network.

2.7.4 Installing Novell NetWare Drivers

The DOS-format distribution diskette (diskette 1) contains the drivers and software for using your controller in NetWare systems.

The software includes ODI drivers for server and DOS client environments, mirrored-server link (MSL) drivers for operation under NetWare SFT III, and SNMP network management software for remote management of your controller.

To install a NetWare driver, refer to Section 2.7.4.1.

The MSL driver can be configured using custom parameters. The custom parameters are described in Section 2.7.4.2.

NOTE

Refer to Section 2.7.5 if you need instructions on loading and viewing the DOS-format distribution diskette.

2.7.4.1 Installing NetWare Drivers

To install a NetWare driver, do the following:

1. Follow the standard NetWare procedures described in your operating system documentation for installing LAN controllers.
2. From the DOS prompt, locate and view the A:\NOVELL\README.TXT file on the DOS-format distribution diskette. This README.TXT file contains the location of the various NetWare README.TXT files.
3. Refer to the appropriate NetWare README.TXT file for more specific installation information.

After you install the driver, proceed to Section 2.9 to connect your system to the network.

2.7.4.2 Using Custom Parameters for NetWare SFT III

The Novell NetWare SFT III mirrored-server link (MSL) drivers contain additional custom driver parameters that are not available to standard MSL drivers.

The following parameters are implemented in the controller MSL drivers. Refer to the corresponding driver `README.TXT` file for the latest list of optional parameters.

NOTE

In all of the following examples, the NetWare SFT III 3.1X MSL driver is loaded from the current default path on drive C: and the controller is installed in slot 5 of the system. Replace the driver name, path, and slot number as appropriate.

Network Coexistence Mode

In a normal mode of operation, the MSL is a point-to-point connection between the two MSL controllers. The controller also allows the link to coexist on an FDDI network as long as there are no routers in the path between the two linked servers.

IMPORTANT

In this mode of operation you must specify the linked server's MSL node address. Failure to do so will result in broadcast packets flooding the network.

To complete the link, keep both MSL adapters disconnected from the network and load the MSL driver on both IOENGINEs as follows:

```
LOAD C:\DECMSL3X.MSL SLOT=5
```

When the driver loads and has initialized the board, the following information is displayed:

```
Local MSL Adapter Address = 08002Bxxxxxx
```

Write down this address and repeat this procedure on the other server to obtain its address.

When you have the addresses for both servers, connect the adapters to the network and load the driver by using the PARTNER command line option to specify the address of the other IOENGINE's MSL adapter.

In the following example, 08002Byyyyyy is the address of the other server's local MSL adapter :

```
LOAD C:DECMSL3X.MSL SLOT=5 PARTNER=08002Byyyyyy
```

Repeat this procedure on the other IOENGINE using this IOENGINE's MSL adapter's address. The IOENGINEs find each other and then report that the link is available. The IOENGINEs synchronize once the server is activated.

Increasing Message Timeout Time

With increasing network traffic, or when the two mirrored servers are a great distance apart, it can become necessary to increase the amount of time a message may take to arrive at the other server. To do this, increase the message timeout, MSGTIMEOUT, to a higher value as follows (in this example, the message timeout is set to 4 clock ticks):

```
LOAD C:DECMSL3X.MSL SLOT=5 PARTNER=08002Byyyyyy MSGTIMEOUT=4
```

Note that the MSGTIMEOUT value is the maximum number of clock ticks (1 clock tick = 1/18 of a second) allowed for an acknowledgment (ACK) packet to be received after a message is transmitted. Increase the number until the link becomes stable.

Increasing Message Retry Count

Running the driver on a busy network increases the possibility for a packet to become lost between the two MSL cards. As your network traffic increases, it can become necessary to increase the retry count.

To adjust the retry count, add the following `RETRY` option to the command line when loading the MSL driver.

```
LOAD C:DECMSL3X.MSL SLOT=5 PARTNER=08002Byyyyyy RETRY=2
```

Full Duplex Operation

The driver can be configured to run in a Digital proprietary mode of operation known as full duplex (FDX). When in this mode, the MSL adapters must be connected in a point-to-point configuration.

In this mode, the normal FDDI token rotation is eliminated, allowing the adapters to send and receive at the same time. This increases the bandwidth of the connection above the 100 megabits/second limitation of standard FDDI.

To activate this mode of operation, add the `FULLDUPLEX=ON` option to the command line when loading the MSL driver:

```
LOAD C:DECMSL3X.MSL SLOT=5 FULLDUPLEX=ON
```

2.7.5 Loading and Viewing the DOS-Format Diskette

To load and view the DOS-format diskette (diskette 1), do the following:

1. Insert diskette 1 into disk drive A.
2. From the DOS prompt, locate and view the appropriate README.TXT file on the DOS-format distribution diskette (diskette 1) as follows:

- a. Type the following command at the DOS prompt:

```
more < readme.txt Return
```

The file is displayed, one screen at a time.

- b. To view the next screen, press the space bar.
- c. To quit viewing the file, press Ctrl/C.

2.8 Installing the SCO UNIX Driver

Perform the following steps to install the SCO UNIX driver:

1. Extract the SCO UNIX release notes and installation notes by completing the following steps:

- a. Log in to your superuser (root) account.
- b. Insert diskette 2 into disk drive A.
- c. Change the default working directory to the root directory (/) by typing:

```
# cd / 
```

- d. Extract the release notes and installation notes by typing:

```
# tar xvf /dev/rfd0 ./usr/lib/dfe/rel_inst.notes 
```

The # prompt appears when the extraction is complete.

- e. Change the default working directory to the /usr/lib/dfe directory by typing:

```
# cd /usr/lib/dfe 
```

- f. Read the text file rel_inst.notes by typing:

```
# more rel_inst.notes 
```

2. Install the SCO UNIX LLI Driver software by following the instructions in the text file rel_inst.notes.

After you install the driver, proceed to Section 2.9 to connect your system to the network.

2.9 Connecting to the Network

This section describes how to connect the FDDI cables (fiber-optic multimode and Category 5 UTP) to the EISA controller and how to verify a good connection to a network device.

If the other end of the FDDI cable is not already connected to the appropriate FDDI network or network device (typically a concentrator), contact the network manager to connect the cable.

Valid FDDI configurations can be implemented as described in the publication *Fiber Distributed Data Interface Network Configuration Guidelines*.

NOTE

Be sure you have installed the appropriate software driver as described in Sections 2.7 and 2.8 before you install FDDI cables.

To install the FDDI cables and verify a network connection, complete the following steps:

WARNING

Some fiber-optic equipment can emit laser light that can injure your eyes. Never look into an optical fiber or connector port. Always assume the cable is connected to a light source.

1. Connect the FDDI cable to the controller:
 - a. To connect the FDDI cables to fiber-optic SAS or DAS controllers, go to Section 2.9.1.
 - b. To connect the FDDI cables to the UTP SAS controller, go to Section 2.9.2.

2.9.1 Fiber-Optic SAS or DAS Controllers

1. Connect the FDDI cable(s); see Figure 2–6.
2. Observe the controller LED(s):

The LED(s) should be a steady green, indicating a proper connection to the FDDI network device. If you observe any other indication, refer to Chapter 3, Table 3–2, to isolate and correct the problem.

3. Go to Section 2.10 to verify proper network operation.

Figure 2–6: Connecting the FDDI Cable to Fiber-Optic SAS or DAS Controllers (DAS Model Shown)

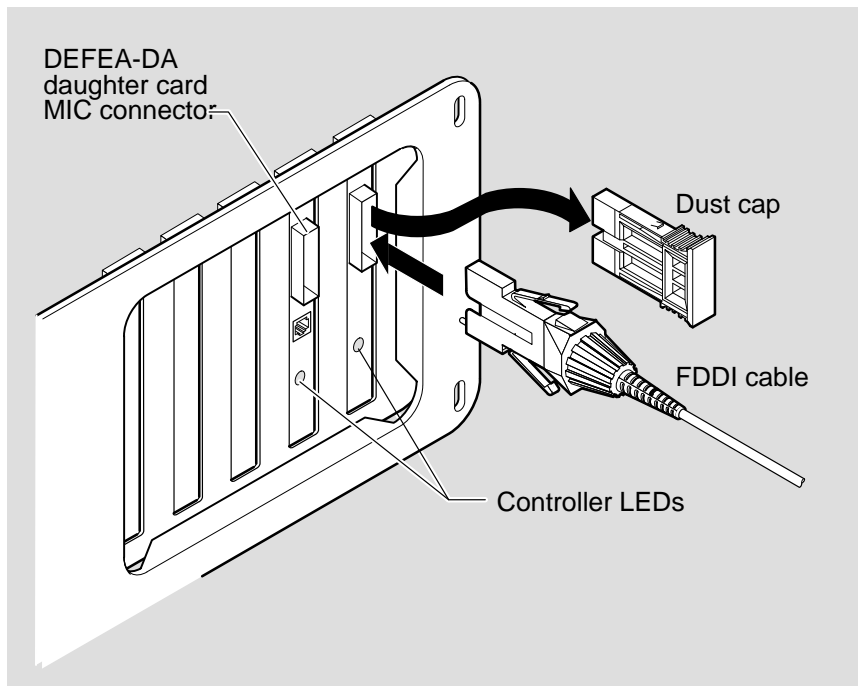

LKG-8911-941

2.9.2 UTP SAS Controller

1. Connect the FDDI cable(s); see Figure 2-7.
2. Observe the controller LED:

The LED should be a steady green, indicating a proper connection to the FDDI network device. If you observe any other indication, refer to Chapter 3, Table 3-2, to isolate and correct the problem.

3. Go to Section 2.10 to verify proper network operation.

Figure 2-7: Connecting the FDDI Cable to the UTP SAS Controller

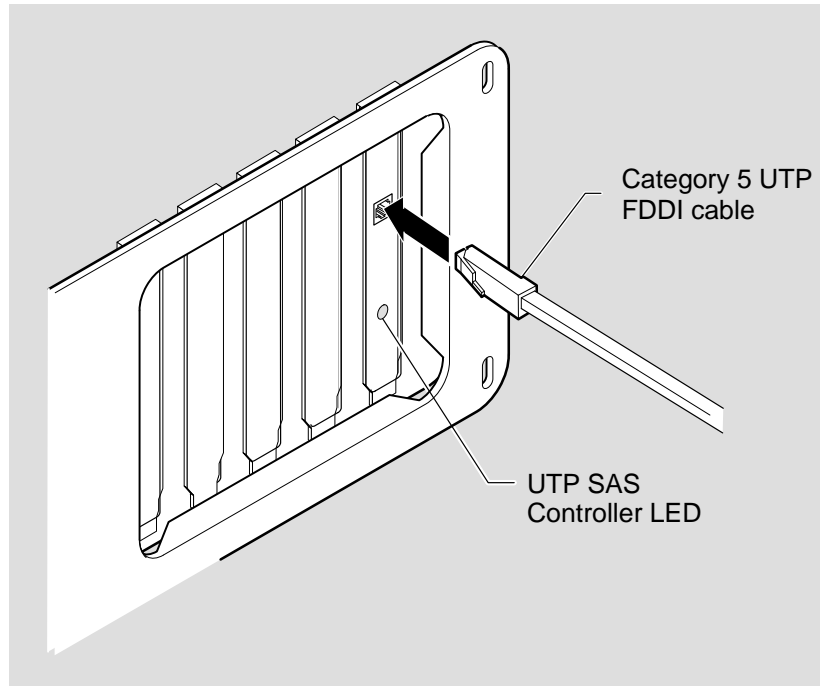

LKG-8912-941

2.10 Verifying the Controller Operation on the Network

To verify that your controller is operational in the network, use your network operating system software, such as the executable file `NETX.EXE` for Novell NetWare clients, to make an interconnection to another node on the network.

If you cannot establish and maintain communications with another node, refer to Chapter 3, Table 3–3, to isolate and correct the problem. If the problem persists, contact your Digital sales representative.

Installation of the controller is now complete.

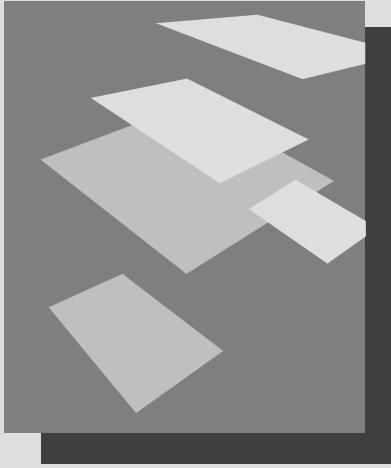

Problem Solving

Isolating Controller, Driver Configuration, and Installation Faults

Diagnosing Problems with a Previously Operational Controller

Isolating Network Connection Faults

Isolating Network Interconnect Faults

Running Self-Test

Running INSTVER Diagnostics

Using the Digital Local Management Application (DECLma)

Problem Solving

This chapter contains tables describing possible problems with the controller hardware/software installation, configuration, connection to the network access device, and network interconnection (communication with a target node). The tables suggest causes and solutions for each symptom.

The diagnostic tables are grouped in the following categories:

- **Controller, Driver Configuration, and Installation Faults** — Refer to Table 3-1 if you experience problems during installation and no FDDI connection has been made.
- **Network Connection Faults** — Refer to Table 3-2 if you experience problems when the controller is first connected to a network access device.
- **Network Interconnect Faults** — Refer to Table 3-3 if you cannot communicate with a target node.

Refer to Section 3.2, *Diagnosing Problems with a Previously Operational Controller*, if you suspect this node/link is causing a communication failure in a network that was previously functional.

This chapter also contains brief descriptions of the controller self-test, INSTVER diagnostics, and the Digital Local Management Application (DECLma). The INSTVER and DECLma utilities are useful tools for diagnosing controller installation and network configuration problems.

3.1 Isolating Controller, Driver Configuration, and Installation Faults

Table 3–1 lists problems that you may encounter when performing the EISA configuration, installing the controller, and installing the driver software.

NOTE

The fault analysis in Table 3–1 assumes both that the computer was operating properly before you began the controller installation process and that no FDDI cable is connected to the controller.

3.2 Diagnosing Problems with a Previously Operational Controller

This section provides information to aid in isolating faults to the optimum field replaceable unit (FRU) or to an associated device that can be the source of the problem.

When diagnosing problems during the initial installation of the controller, use Table 3–1, Table 3–2, and Table 3–3. These tables list symptoms, probable causes, and suggest corrective actions to remedy problems related to possible installation faults.

3.2.1 Normal Powerup

During system powerup, or during a node reset, the EISA controller automatically initiates its self-test and verifies the CPU logic in the unit. The LED on the controller (and, if applicable, on the daughter card) indicates whether the controller passed or failed the self-test.

3.2.2 Problem-Solving Tips

Consider the following tips before you begin the problem-solving procedures :

- To prevent damage to the circuit cards, use the antistatic ground strap when handling the cards.
- Consider that power fluctuations, high ambient temperatures, and interference from other equipment may be responsible for possible environmental problems.

3.2.3 Problem-Solving Tools

The following tools are not supplied but can be ordered from Digital Equipment Corporation:

- A nonattenuated FDDI loopback connector (Part Number: 12-32005-01) for testing the FDDI port.
- A UTP loopback connector, for DEFEA-UA models only, option number H4082-AC (Part Number: 12-35619-03).

Table 3–1: Isolating Controller and Driver Configuration and Installation Faults

Symptom	Probable Cause	Corrective Action
System is on; no display.	The controller card is not seated firmly.	Turn off the system and reseal the card firmly.
	The memory address of the EISA card conflicts with another option or video card installed in an EISA slot.	Reconfigure the controller using different memory mapping. If the problem persists, contact your system administrator or your Digital sales representative.
System is on, but there is no response from the keyboard.	The card settings conflict with another card in the system.	Reconfigure the controller using different IRQ level settings and/or memory mapping.

Table 3–1 (Cont.): Isolating Controller and Driver Configuration and Installation Faults

Symptom	Probable Cause	Corrective Action
System is on; LED is red.	With no FDDI cable connected, the controller is suspect.	Reboot the system and watch the self-test. If the problem persists, contact your Digital sales representative.
The computer display indicates a slot configuration error.	SAS or DAS controller was inserted into a slot other than the one designated by the configuration utility.	Turn off the system and insert the controller into the correct slot. If the problem persists, refer to Section 2.4 and repeat the configuration process.
The computer display indicates a configuration error, with no controller present.	The system was configured for an EISA controller, but didn't find one.	Install the controller.
The computer display indicates that the system found an unrecognized card.	The controller was installed before the system was configured.	Turn off the system and remove the controller. Repeat the configuration process. Refer to Section 2.4.

3.3 Isolating Network Connection Faults

Table 3–2 lists problems that you may encounter when you connect the controller to a network device, such as a concentrator, through an FDDI cable.

NOTE

The fault analysis in Table 3–2 assumes both that the computer was operating properly before you began the EISA installation process and that the controller self-test passes with the FDDI cable attached.

Table 3–2: Isolating Network Connection Faults

Symptom	Probable Cause	Corrective Action
Controller LED sequentially cycles to solid red (for 50 seconds), then to solid green for a period of time, and then to solid red again (repeatedly).	Faulty cable between the controller and concentrator (Link Error Rate threshold exceeded).	Replace the cable. If the fault persists, a problem with either the concentrator port or the controller is likely.
System is on. Controller LED is flashing red.	Invalid topology.	Use a valid topology configuration. Use the DECima <code>show SMT</code> command to view the current connection capabilities. Refer to the DECima documentation for details.

Table 3–2 (Cont.): Isolating Network Connection Faults

Symptom	Probable Cause	Corrective Action
System is on. Controller LED is steady red.	Network problem.	Disconnect the controller cable. If the LED flashes green, the controller is functional. Reconnect the cable, try a new cable, or connect to a different concentrator port.
	Controller problem.	Disconnect the controller cable. If the LED remains red, the controller might be at fault. Reboot the system and watch the self-test. If the problem persists, contact your Digital sales representative.
Controller LED continues to flash green and does not change to solid green when the cable is connected.	Driver not installed correctly.	If the software driver is installed correctly, and the controller is configured properly, then refer to the file <code>README.TXT</code> in subdirectory <code>A:\DIAG</code> of diskette 1 for information on running the <code>INSTVER</code> network diagnostics (also refer to Section 3.6).
	Faulty controller cable or connection.	Verify the integrity of the controller cable. Replace if defective.
	Faulty FDDI concentrator.	Verify the integrity of the concentrator. Replace if defective.

Table 3–2 (Cont.): Isolating Network Connection Faults

Symptom	Probable Cause	Corrective Action
(Continued)	Faulty controller.	<p>Connect a loopback connector (use part number 12-32005-01 for the MIC connector or part number 12-35619-03 for the UTP connector).</p> <p>If the port LED for the connector changes to solid green, a problem exists with the cable or the concentrator.</p> <p>If the port LED continues flashing green, replace the EISA controller.</p> <p>If no loopback connector is available, test the cable between the concentrator and the EISA controller.</p> <p>If you verify that the cable is good, test the concentrator. If the concentrator is functional, replace the controller.</p>
Controller LED remains off.	<p>Controller is management disabled.</p> <p>Controller driver is not installed properly.</p> <p>Network operating system software is not enabled.</p>	<p>Enable the port using DECima (refer to Section 3.7).</p> <p>Reinstall the appropriate driver. If the fault persists, replace the controller.</p> <p>Refer to your network operating system documentation.</p>

3.4 Isolating Network Interconnect Faults

Table 3–3 lists problems that you may encounter when you establish communication with a target node. Fault isolation at this level is beyond the scope of installing the controller.

Table 3–3: Isolating Network Interconnect Faults

Symptom	Probable Cause	Corrective Action
Cannot establish a connection to another node.	Target node is not in network operating system database.	Add the node to the database.
	Duplicate address on network.	Use DECima to determine if a duplicate address exists.
	Novell NetWare server and client have incompatible frame types (for example, an FDDI_SNAP server cannot connect to an FDDI_802.2 client.	Using DECima, enter the <code>select</code> command to display a unique identifier, the slot number, controller type, and frame type for each DEC FDDI controller driver currently running. Make sure the client and server frame types are compatible.
	A physical path does not exist between the host and target node.	Verify that the target node is running and on the network.

This information is supplied as a transition to network node configuration considerations because the functional operation of an FDDI-connected node involves the performance and integrity of the network. Some but not all considerations include the network address (duplicate address) and controller token rotation time.

The host in which the controller is installed might not be configured properly in the network. An inappropriate network configuration can result in symptoms that make it appear that the controller is malfunctioning when the problem is elsewhere.

NOTE

The fault analysis in Table 3-3 assumes that the computer was operating properly before you began the EISA installation process, and that the controller self-test passes with the FDDI cable attached.

3.5 Running Self-Test

The controller powerup self-test checks much of the onboard CPU-associated hardware up to (but not including) the network interface power optics and connector circuits.

The INSTVER diagnostics (described in Section 3.6) test other controller logic not covered by the self-test.

3.6 Running INSTVER Diagnostics

INSTVER is a DOS-based utility containing the controller's system diagnostic tests. These tests verify the installation beyond the powerup self-test capabilities to include the controller buffer RAM, optical transceiver, MIC connection, and the FDDI cable to/from a network device port such as a concentrator.

Run these diagnostics when you suspect a hardware or network connection problem not indicated by the self-test. You can use the diagnostics as a fault isolation tool when problem solving as described in Table 3-1, Table 3-2, and Table 3-3.

INSTVER checks and reports the status of the following controller logic functions:

- The bus controller chip test verifies proper operation of this chip. This test verifies controller addressing.
- The buffer RAM test verifies the data storage capability of the controller RAM.

- The internal loopback test verifies the controller's ability to send/receive an FDDI frame out to (but not including) the controller's optical transceiver.
- The external loopback test verifies the controller's ability to send/receive an FDDI frame to/from the network.
- The **display controller address** command displays the physical address of the controller.
- The **display revisions** command displays the hardware and firmware revisions.

This utility is located on diskette 1 in the subdirectory A:\DIAG\INSTVER.EXE. Refer to the README.TXT file in this same subdirectory for the diagnostic requirements and instructions for running INSTVER.

3.7 Using the Digital Local Management Application (DECLma)

DECLma is a standalone utility for network personnel responsible for configuring, assessing the status of, and diagnosing problems with controller interfaces.

Using simple command lines, you can access the FDDI (SMT, MAC, PORT, and ATTACHMENT) and INTERFACE group objects, as described in the IETF SNMP FDDI MIB, MIB-II, and DEC Vendor MIB extensions.

You can manage objects contained in the above MIBs as follows:

- Display objects in the following groups:
 - INTERFACE (MIB-II and DEC MIB extensions)
 - SMT (SNMP FDDI MIB and DEC MIB extensions)
 - MAC (SNMP FDDI MIB and DEC MIB extensions)

- PORT (SNMP FDDI MIB and DEC MIB extensions)
- ATTACHMENT (SNMP FDDI MIB)
- Display counter objects from all of the groups just listed.
- Set configurable parameters where valid for an FDDI object.
- Display network events.
- Display and/or dump the contents of the error logger to a file.

The `DECLMA.DOC` file that contains the *Digital Local Management Application User's Guide* is located in `A:\DECLMA`. The `DECLma` application executable files are located (along with the device driver) in the supported platform-specific subdirectories of the distribution diskettes. Each platform subdirectory also contains instructions in its `README.TXT` file for installing `DECLma`.

For `SCO UNIX`, the executable is located in `/usr/bin` and can be executed from any path by typing `declma` `[Return]`. Additionally, `declma.doc` is in the subdirectory `/usr/lib/dfc`.

Configurations and Specifications

This appendix lists the controller's physical characteristics, describes the configuration utility, and lists the controller's operating environment and power requirements.

A.1 Physical Description

The controller is a full-length IBM AT form-factor card that uses the full EISA-specified, 32-bit bus connector.

The major components on the controller card are as follows:

- 1 megabyte of packet memory
- 68000 onboard processor
- DMA control gate array
- EISA bus interface control logic
- FDDI interface chipset
- FDDI optical or TP-PMD interface
- IEEE address ROM
- Onboard, nonvolatile memory for firmware storage

- Multimode Physical Layer Medium Dependent (for models DEFEA-AA and DEFEA-DA)
- ANSI TP-PMD (for model DEFEA-UA)

A.2 Controller Configurations

The configuration files on diskette 1 inform the utility of all the possible configuration settings. The utility program configures the controller for operation in the system.

The controller is allocated a specific interrupt-request (IRQ) line and memory address range (see Table A-1). The configuration utility makes these selections. In most cases they are adequate; however, if there is a conflict with another controller, you can use the utility to change them.

Refer to A:\CONFIG\README.TXT on disk 1 for additional configuration information regarding memory address range and IRQ selections.

The IRQ selections for the controller are as follows:

- IRQ9
- IRQ10
- IRQ11
- IRQ15

Shared and not-shared interrupts are supported.

Table A–1: Memory Address Range Selections

Memory Buffer Size		
32K	1K	0K
C0000-C7FFF	C0000-C0400	Disable Adapter RAM
C8000-CFFFF	C2000-C2400	
D0000-D7FFF	C4000-C4400	
D8000-DFFFF	C6000-C6400	
E0000-E7FFF*	C8000-C8400	
E8000-EFFFF*	CA000-CA400	
	CC000-CC400	
	CE000-CE400	
	D0000-D0400	
	D2000-D2400	
	D4000-D4400	
	D6000-D6400	
	D8000-D8400	
	DA000-DA400	
	DC000-DC400	
	DE000-DE400	
	E0000-E0400*	
	E2000-E2400*	
	E4000-E4400*	
	E6000-E6400*	
	E8000-E8400*	
	EA000-EA400*	
	EC000-EC400*	
	EE000-EE400*	

*Some systems do not support the E0000-EFFFF, E0000-E7FFF, or E8000-EFFFF memory address ranges; check your system manual for this information.

A.3 Specifications

Table A-2 lists the operating environment and power requirements for the controller.

Table A-2: Operating Environment and Power Requirements

Specification	Rating
Operating temperature (at sea level)	10° C to 40° C (50° F to 104° F)
Nonoperating temperature	-40° C to 85° C (-40° F to 185° F)
Relative humidity	8% to 80% (noncondensing)
Radiated emissions	FCC Class B VDE Class B
Power requirements	DC amps @ +5V, 3.5 A (maximum) DC amps @ +12V, 0.1 A (maximum) Bus loading – per EISA standard

CAUTION 

When adding any option module to your computer, verify that the combined power (wattage) required for all modules in your computer does not exceed the power supply rating. Check your computer documentation for this information.

B

Optical Bypass and FDDI Connectors

This appendix describes the controller's connectors and connector keying arrangements.

B.1 Optical Bypass Relay (OBR) RJ-12 Connector

The OBR connector (see Figure B-1) allows an OBR device to maintain FDDI dual-ring integrity if the controller fails or its power is turned off. The OBR is available only on the DAS multimode version of the controller (DEFEA-DA).

Refer to this information when selecting optical bypass devices.

WARNING

To prevent personal injury or equipment damage, **do not** insert telecommunications cabling into the optical bypass relay connector.

Figure B-1: RJ-12 (OBR) Pin Assignments

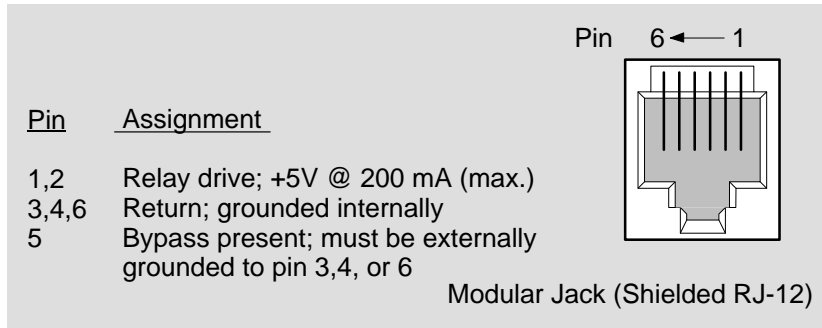

LKG-8720-931

B.2 FDDI Connector Keying

Media interface connectors (MICs) for FDDI multimode interface connections are used with SAS and DAS EISA controllers.

The MIC connectors are keyed to allow the fiber-optic cable connectors to align properly. The three types of connectors used on the controller are MIC A and MIC B for the DAS controller and MIC S for the SAS controllers (see Figure B-2). Note that the controllers connect to either a MIC M type connector of a concentrator or the A and B ports of another FDDI device.

Figure B-2: Media Interface Connector Keying

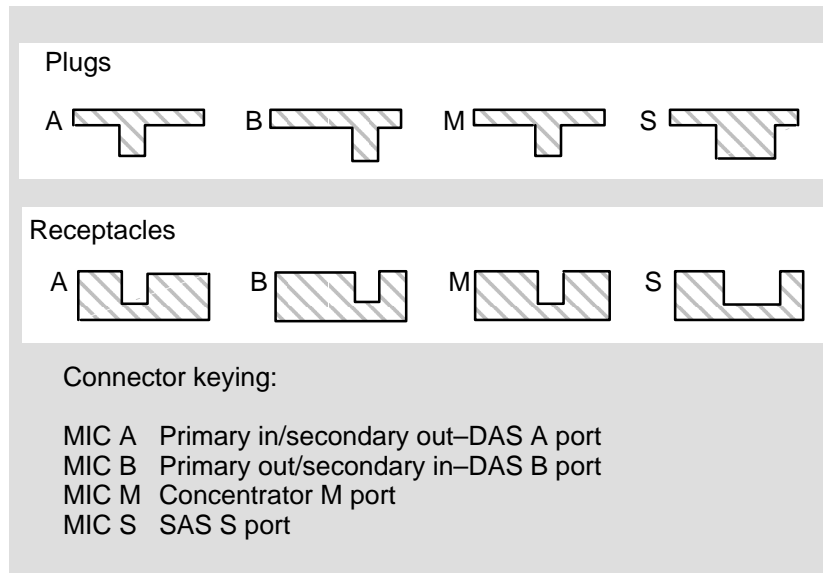

LKG-6859-921

The position of the keyway on the MIC plug determines the type of receptacle to which it connects. All MIC plugs fit into a MIC “S” receptacle. Type A, B and M MIC plugs and receptacles must match for proper installation.

B.3 Installing Optional PHY Port Key

ANSI multimode PMD cards ship with a PHY S key installed. Optional PHY A, PHY B, and PHY M keys ship separately. The PHY key type is clearly marked on the top of each key.

To change the key, refer to Figure B-3 and do the following:

1. Use a pointed tool, such as a screwdriver, and release the front edge of the PHY key. Do not use a pencil.
2. Slide the key forward and remove it.
3. Tip the replacement key in place and press down.

Figure B-3: Changing the PHY Port Key

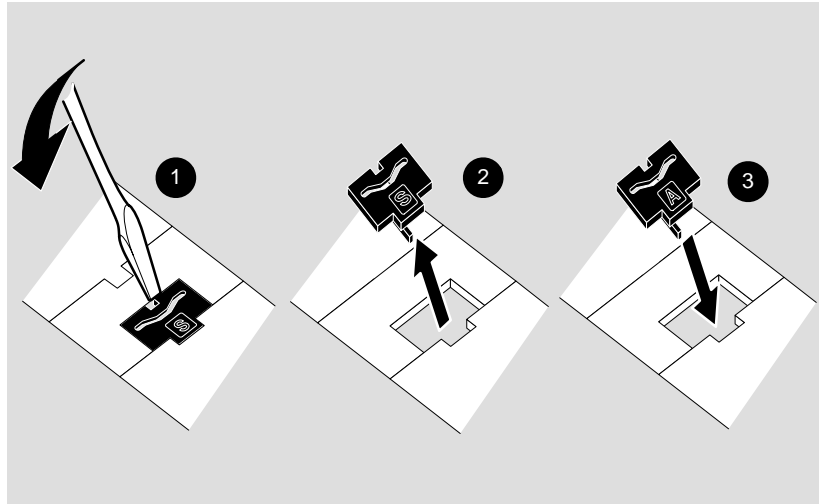

LKG-6937-92I

Accessing MIBs and RFCs

This appendix describes how to access Digital's private Management Information Base (MIB) and Request For Comments (RFCs).

Public MIBs can be accessed over the Internet network using any of the following methods:

- Electronic mail
- `ftpmail`
- Anonymous `ftp`
- Diskette (for some Digital products)

You can use these methods to access up-to-date FDDI MIBs, as described in the following sections.

C.1 Using Electronic Mail

The DDN Network Information Center (NIC) of SRI International provides automated access to NIC documents and information through electronic mail. This is especially useful for people who do not have access to the NIC from a direct Internet link, such as BITNET, CSNET, or UUCP sites.

To use the mail service, follow these instructions:

1. Send a mail message to `service@nic.ddn.mil`
2. In the SUBJECT field, request the type of service that you want, followed by any needed arguments.

Normally the message body is ignored, but if the SUBJECT field is empty, the first line of the message body is taken as the request. The example at the end of Section C.2 lists some of the services available.

Requests are processed automatically once a day. Large files are broken down into separate messages. However, a few files are too large to be mailed.

C.2 Using ftpmail

Digital offers Internet ftpmail access to private MIB information, in ASCII text form, at `gatekeeper.dec.com`, with up-to-date documents stored in the `/pub/DEC/mib` directory. Check the INDEX file and the README file for the current contents.

To use ftpmail, follow these instructions:

1. Send a mail message to:
`ftpmail@gatekeeper.dec.com`.
2. Ignore the subject line.
3. Include the word “connect” in the first line of the body.
4. Include get commands for each document required; for example:

```
get /pub/DEC/mib/README
```

Requests are acknowledged, then queued and processed every 30 minutes. Because of the number of requests, it may take a day or two before you receive a reply.

NOTE

For more timely access, consider using anonymous ftp (refer to Section C.3).

The following are example SUBJECT lines to obtain DDN NIC documents:

HELP

RFC 822

RFC INDEX

RFC 1119.PS

FYI 1

IETF 1IETF-DESCRIPTION.TXT

INTERNET-DRAFTS 1ID-ABSTRACTS.TXT

NETINFO DOMAIN-TEMPLATE.TXT

SEND RFC: RFC-BY-AUTHOR.TXT

SEND IETF/LWG-SUMMARY.TXT

SEND INTERNET-DRAFTS/DRAFT-IETF-NETDATA-NETDATA-00.TXT

HOST DIIS

C.3 Using Anonymous ftp

You can obtain RFCs and up-to-date FDDI MIBs from Digital using anonymous ftp.

Digital offers Internet anonymous ftp access to private MIB information, in ASCII text form, at `gatekeeper.dec.com`, with up-to-date documents stored in the `/pub/DEC/mib` directory. Check the `INDEX` file and the `README` file for the current contents.

To use anonymous ftp to copy files, follow these instructions:

NOTE

User input is case sensitive; you must type it as shown.

1. Use the Internet application `ftp` to connect to `gatekeeper.dec.com`. The Internet address is `16.1.0.2`.
2. Log in as user `anonymous`.
3. Use your electronic mail address as the password.
4. Use the `cd` command to get to the `/pub/DEC/mib` directory.
5. Use the `ascii` command to specify that you are retrieving ASCII text files.
6. Use the `get` command to get the file, or files, that you require.
7. Use the `quit` command to log out when you are finished.

The following example shows how to copy the `README` file from the repository:

NOTE

In the following example, user input is shown in **bold** text.

```
% ftp gatekeeper.dec.com
Connected to gatekeeper.dec.com
220 GATEKEEPER.DEC.COM FTP Service Process
Name: anonymous
331 ANONYMOUS user ok, send real ident as password.
Password: milano@netman.stateu.edu
230 User ANONYMOUS logged in at Tue 10-Aug-1993 10:24-EST, job 54.
ftp> cd /pub/DEC/mib.
331 Default name accepted. Send password to connect to it.
ftp> ascii
220 Type A ok.
ftp> get README
200 Port 19.54 at host nnn.nn.nn.nn accepted.
150 ASCII retrieve of /pub/DEC/mib/README started.
226 Transfer completed. 40239 (8) bytes transferred.
40239 bytes received in 23.65 seconds (5.8 Kbytes/s)
ftp> quit
%
```

C.4 Obtaining a Diskette

You can obtain a free diskette containing the latest FDDI RFCs and Digital's private MIBs. To obtain a diskette, call 800-DIGITAL, press 2, and ask for presales technical support. Request the FDDI RFC and Digital's private MIB diskette.

Index

A

Accessing MIBs, C-1
 obtaining a diskette, C-5
 using anonymous ftp, C-4
 using electronic mail, C-1
 using ftpmail, C-2
Anonymous ftp, accessing
 MIBs with, C-4

C

Changing PHY port key, B-2
Configuration
 files, 2-7, A-2
 procedure, 2-6
 utility, 2-6, A-2
Controller
 cabling, 2-24
 components, A-1
 configurations, A-2

 connection to FDDI networks,
 1-2
 description, 1-4, 1-5, 1-6,
 A-1
 diagnostics, 1-4, 1-5, 1-6
 installation, 2-8
 kit contents, 2-2
 models, 1-1
 part numbers, 2-7
 specifications. *See* Specifications
 tions
 verifying installation, 2-14
 verifying network operation,
 2-27
Custom parameters, 2-19
 full duplex operation, 2-21
 increasing message retry
 count, 2-21
 increasing message timeout
 time, 2-20
 network coexistence mode,
 2-19

D

- DEClma, 3–11
- DEFEA-AA
 - description, 1–4
 - installation, 2–11
- DEFEA-DA
 - description, 1–6
 - installation, 2–13
- DEFEA-UA
 - description, 1–5
 - installation, 2–12
- Device driver, software, 1–9
- Diagnostics, INSTVER, 3–10
- Display
 - controller address, 3–11
 - objects, 3–11
 - revisions, 3–11
- Distribution diskettes, 1–9
 - contents, 1–9
 - diskette 1, 1–9
 - diskette 2, 1–10
 - DOS format, 1–9
 - example of structure, 1–11
 - loading and viewing, 2–22
 - SCO UNIX format, 1–10
 - types of, 2–2
- Driver installation
 - DOS NDIS 2.01, 2–15
 - DOS-format, 2–15
 - NetWare, 2–18
 - OS/2 NDIS 2.01, 2–16
 - SCO UNIX, 2–23
 - Windows NT, 2–17

Duplicate address, 3–9

E

- Electronic mail, accessing MIBs
 - with, C–1

F

- Fault isolation, 3–2
- ftpmail, accessing MIBs with,
 - C–2

I

- IBM AT form-factor card, A–1
- Installation
 - connecting cables, 2–24
 - DAS (DEFEA-DA), 2–13
 - preparing for, 2–4
 - problems, 3–2
 - requirements, 2–4
 - SAS (DEFEA-AA), 2–11
 - steps, 2–1
 - tools, equipment required, 2–4
 - UTP SAS (DEFEA-UA),
 - 2–12
 - verifying, 2–14
- INSTVER diagnostics, 3–10
- IRQ level settings, 2–7
- Isolating network connection
 - faults, 3–6
- Isolating network interconnect
 - faults, 3–9

L

LEDs

- description, 1–7
- states, 1–7
- verifying connection, 2–25, 2–26
- verifying installation, 2–14

Loading and viewing DOS-format diskette, 2–22

Loopback

- external, 3–11
- FDDI port, 3–3
- internal, 3–11
- UTP port, 3–3

M

Management Information Base. *See* MIBs

Memory address range, A–2

MIBs, 3–11, C–1

- accessing with anonymous ftp, C–4
- accessing with electronic mail, C–1
- accessing with ftpmail, C–2
- obtaining via diskette, C–5

MIC connector, keying, B–2

N

NetWare, driver installation, 2–18

NetWare drivers, custom parameters, 2–19

Network

- configuration, 1–3
- connecting to, 2–24
- establishing connection to another node, 2–27
- operating software, 1–9

Network connection faults, isolating, 3–6

Network interconnect faults, isolating, 3–9

O

OBR connector. *See* Optical bypass relay

Operating system, 1–9

Optical bypass relay, 1–7, B–1

Option slot cover, removal, 2–9

P

Package contents, checking, 2–2

PHY port key, changing, B–2

Preparing for installation, 2–4

Problem solving

- FDDI loopback connector, 3–3

- previously operational controller, 3–2

- tips, 3–3

- tools, 3–3

- UTP loopback connector, 3–3

Product kit, 2–3

R

README.TXT, 1–10

Requirements

DOS, 2–5

SCO UNIX, 2–5

software, 2–4

system, 2–4

RFCs. *See* MIBs

RJ-12 connector. *See* Optical
bypass relay

S

SCO UNIX

driver installation notes, 2–23

release notes, 2–23

Self-test, 3–10

Software

description, 1–9

operating system, 1–9

verifying, 2–4

Specifications

operating environment, A–4
power requirements, control-
ler, A–4

radiated emissions, A–4

relative humidity, A–4

temperature, A–4

Static electricity, 2–2

System requirements, verifying,
2–4

V

Verifying connection to network
device, 2–24

Verifying contents of shipment,
2–2

Verifying controller installation,
2–14

Verifying network operation,
2–27

Verifying system and software
requirements, 2–4

Verifying system memory re-
quirements, 2–5

HOW TO ORDER ADDITIONAL DOCUMENTATION

DIRECT TELEPHONE ORDERS

In Continental USA
call 1-800-DIGITAL
(1-800-344-4825)

In Canada
call 800-267-6215

In New Hampshire,
Alaska or Hawaii
call 603-884-6660

ELECTRONIC ORDERS (U.S. ONLY)

Dial 800-dec-demo with any VT100 or VT200
compatible terminal and a 1200 baud modem.

If you need assistance, call 1-800-DIGITAL (1-800-344-4825)

DIRECT MAIL ORDERS (U.S. and Puerto Rico*)

DIGITAL EQUIPMENT CORPORATION
P.O. Box CS2008
Nashua, New Hampshire 03061

DIRECT MAIL ORDERS (Canada)

DIGITAL EQUIPMENT OF CANADA LTD.
940 Belfast Road
Ottawa, Ontario, Canada K1G 4C2
Attn: A&SG Business Manager

INTERNATIONAL

DIGITAL EQUIPMENT CORPORATION
A&SG Business Manager
c/o Digital's local subsidiary
or approved distributor

Internal orders should be placed through U.S. Software Supply Business (SSB),
Digital Equipment Corporation, 10 Cotton Rd. Nashua, NH. 03063-1260

*Any prepaid order from Puerto Rico must be placed
with the Local Digital Subsidiary:
809-754-7575

READER'S COMMENTS

What do you think of this manual? Your comments and suggestions will help us to improve the quality and usefulness of our publications.

Please rate this manual:

	Poor				Excellent
Accuracy	1	2	3	4	5
Readability	1	2	3	4	5
Examples	1	2	3	4	5
Organization	1	2	3	4	5
Completeness	1	2	3	4	5

Did you find errors in this manual? If so, please specify the error(s) and page number(s).

General comments:

Suggestions for improvement:

Name	Date	
Title	Department	
Company	Street	
City	State	Zip

DO NOT CUT – FOLD HERE AND TAPE

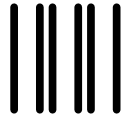

NO POSTAGE
NECESSARY
IF MAILED
IN THE
UNITED STATES

BUSINESS REPLY LABEL

FIRST CLASS PERMIT NO. 33 MAYNARD MASS.

POSTAGE WILL BE PAID BY ADDRESSEE

digitalTM

**Telecommunications and
Networks Publications**
550 King Street
Littleton, MA 01460-1289

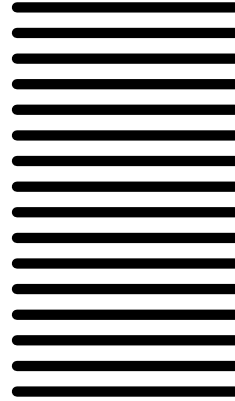

DO NOT CUT – FOLD HERE

digital™

Printed in U.S.A.