

DECmedia

User's Guide

Order Number: EK-DECME-UG-001

Revision Update Information: Version 1.0

Digital Equipment Corporation
Maynard, Massachusetts

First Printing, January 1992

The information in this document is subject to change without notice and should not be construed as a commitment by Digital Equipment Corporation.

Digital Equipment Corporation assumes no responsibility for any errors that may appear in this document.

The software described in this document is furnished under a license and may be used or copied only in accordance with the terms of such license.

No responsibility is assumed for the use or reliability of software on equipment that is not supplied by Digital Equipment Corporation or its affiliated companies.

Restricted Rights: Use, duplication, or disclosure by the U.S. Government is subject to restrictions as set forth in subparagraph (c)(1)(ii) of the Rights in Technical Data and Computer Software clause at DFARS 252.227-7013.

© Digital Equipment Corporation 1992.

All rights reserved.
Printed in U.S.A.

The Reader's Comments form at the end of this document requests your critical evaluation to assist in preparing future documentation.

The following are trademarks of Digital Equipment Corporation: DEC, DECstation, DECwindows, DIGITAL, TURBOchannel, ULTRIX, XMedia and the DIGITAL logo.

RCA is a trademark of Radio Corporation of America.

S1693

This document is available on CDROM.

This document was prepared with VAX DOCUMENT, Version 1.2.

FCC NOTICES

Class A Part 15 Notice

The equipment described in this manual generates, uses, and may emit radio frequency energy. The equipment has been type tested and found to comply with the limits for a Class A computing device pursuant to Subpart J of Part 15 of FCC Rules. These limits are designed to provide reasonable protection against such radio frequency interference when operated in a commercial environment. Operation of this equipment in a residential area may cause interference, in which case the user at his own expense may be required to take measures to correct the interference.

Part 68 Notice

The DECAudio product has been approved by the Federal Communications Commission (FCC) as not being harmful to a telephone network when connected to it.

Please adhere to the following guidelines:

1. Use standardized plugs for connections.
2. Do not use the DECAudio product on party lines or coin lines.
3. If the local telephone company requests information, advise them that you have connected an FCC registered device (with the required USOC jack) to their lines. Provide the following information:
 - a. FCC Registration Number: A09USA-18900-VM-E
 - b. Ringer Equivalence Number (REN): 0.9B
 - c. Telephone number this unit is connected to

The FCC registration number and Ringer Equivalence Number (REN) are indicated on the label on the back of DECAudio distribution box. The ringer equivalence number determines how many devices can be connected to your telephone line. In most areas, the sum of the RENs of all

devices on any one line should not exceed five. If too many devices are attached to the line, they may not ring properly.

If the DECAudio product malfunctions, it may cause harm to the telephone network. In this case, disconnect the device until you can determine the source of the problem and until the device is repaired or replaced. If this is not done, the telephone company may temporarily disconnect services.

Your telephone company may make changes in its technical operations and procedures that affect the operation or use of the DECAudio device. Your telephone company is required to give adequate notice of the changes. You will be advised of your right to file a complaint with the FCC.

Contents

FCC NOTICES	iii
Preface	ix
1 The Multimedia Product Set	
DECmedia Multimedia Products	1
XMedia Software	5
TURBOchannel	7
2 DECAudio Installation	
Unpacking DECAudio Hardware	10
Installing the DECAudio Module	12
Connecting Cables to the DECAudio Module	19
Checking the Configuration Display	29
Diagnosing and Solving Problems	30
3 TX and DECvideo/PIP Installation	
Unpacking TX Hardware	34
Installing the TX Module	35
Unpacking DECvideo/PIP Hardware	44
Installing the DECvideo/PIP Module	45
Connecting Cables	49
Checking a TX Configuration	56
Diagnosing and Solving Problems	57

4 Connecting Peripherals

Connecting a Television	59
Connecting a Laser Disc Player	60
Speakers and Headphones	61
Multimedia Workstation	62

A For the Digital Service Representative

B Hardware Specifications

Glossary

Index

Figures

1	Contents of DECAudio Option Package	11
2	Attaching Antistatic Strap	13
3	Removing the Options Slot Cover	14
4	Inserting a DECAudio Module into TURBOchannel Option Slot	15
5	Pushing Module onto Support Posts	16
6	Securing Module to TURBOchannel	17
7	Securing Module to System Unit	18
8	Removing the Label	19
9	Connecting a Telephone and Telephone Line	20
10	Connecting Distribution Cable	21
11	Distribution Cable Connectors	22
12	DECAudio Distribution Box (Front View)	23
13	DECAudio Distribution Box (Back View)	24
14	DECAudio Distribution Box (Back View)	25
15	Power Supply	26
16	Stand	27
17	Contents of TX Option Packages	34
18	Attaching Antistatic Strap	36
19	Removing the Options Slot Cover	37
20	Lifting the Board Away from Support Posts	38

21	Sliding the Frame Buffer Out of Option Slot Opening	39
22	Inserting the TX Color Frame Buffer	40
23	Pushing the Module onto Support Posts	41
24	Securing the TX Module	42
25	Contents of DECvideo/PIP Option	44
26	Attaching Antistatic Strap	46
27	Adding the AV10U Label	47
28	Attaching the DECvideo/PIP module	48
29	Attaching the Strain Relief Strap to the Monitor Cable	50
30	Attaching Monitor Cable	51
31	Attaching the Video Input Cable	52
32	RGBS Connectors	54
33	Attaching S-Video Cable	55
34	Example Video Conferencing Configuration	63
35	Cable Connections for a DECspin Video Conferencing Workstation	65

Tables

1	Multimedia Configurations	4
2	Mnemonics in TURBOchannel Error Messages	32
3	Next Step	43
4	Using the Video Input Cable Connectors Correctly	53
5	Failed Self-Tests for the TX Color Frame Buffer Module	57
6	DECmedia Hardware Field Replaceable Units	67
7	DECAudio Specifications	69
8	DECAudio Non-operating Conditions	71
9	DECAudio Operating Conditions	71
10	DECAudio Power Requirements	71
11	DECAudio Distribution Box Connectors Type and Function	72
12	DECAudio Interface Connector and Cable	72
13	TX, DECvideo/PIP Non-operating Conditions	72
14	DECvideo/PIP Operating Conditions	72

Page viii is a blank page

Preface

Purpose of This Guide

This guide describes Digital Equipment Corporation multimedia products. An overview of hardware, software, standards, and peripherals is included.

Instructions for adding DECAudio, TX, and DECvideo/PIP hardware modules to a workstation TURBOchannel are included.

Who Should Use This Guide

This guide is intended for any individual responsible for installing and troubleshooting DECAudio, TX, and DECvideo/PIP multimedia options.

Structure of This Guide

This guide contains four chapters, two appendixes, a glossary, and an index.

- Chapter 1 describes the DECAudio, TX, and DECvideo/PIP multimedia products, and TURBOchannel interconnect technology; it also provides an overview of the XMedia Tools software with which you can develop multimedia applications, and lists peripherals you may wish to use.
- Chapter 2 shows you how to install the DECAudio hardware and describes diagnostics that assist you in solving problems.
- Chapter 3 shows you how to install the DECvideo hardware and describes diagnostics that assist you in solving problems.
- Chapter 4 shows you how to connect peripherals to your multimedia workstation.

- Two appendixes list:
 - Digital Services information
 - Hardware specifications
- A glossary defines frequently used multimedia terms
- An index provides references to information within the guide

Conventions

The following conventions are used in this guide:

Warning	Warnings contain information to prevent personal injury. Read these carefully.
Caution	Cautions provide information to prevent damage to equipment or software. They alert the viewer to safety considerations.
Note	Notes provide general information about the current topic.

Margin Icons

Throughout this guide, icons appear in the margins. The meanings of these visual cues are briefly explained here.

Cross-Reference

Refers you to another manual and then returns you here.

On/Off Switch (On)

Directs you to turn on (I) one or more devices.

On/Off Switch (Off)

Directs you to turn off (O) one or more devices.

Handset

Indicates the connectors or controls for a telephone-style handset.

Headset

Indicates a headset to be used with the DECAudio product.

Headphones

Indicates headphones to be used with the DECAudio product.





Microphone

Indicates that a microphone is to be used with the DECAudio product.



Sound/Audio

Identifies the audio controls on a DECAudio product, or indicates an audio peripheral.



Phono plug

Identifies an RCA-style phono plug (U.S.). Also known as a phono plug.



Speaker

Alerts you to a discussion of the speakers to be used with the DECAudio product.



Video

Identifies a discussion of video signals.



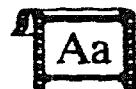
DECmedia Clapboard

Alerts you to a discussion of the DECmedia family of multimedia products.



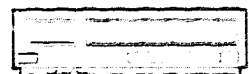
TX Frame

Identifies the TX color frame buffer.



DECvideo/PIP Frame

Identifies the Picture-in-a-Picture (PIP) enhancement to the TX color frame buffer.



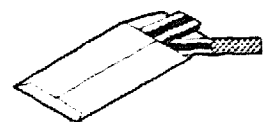
VCR

Identifies a video cassette recorder.



Laser Disc

Identifies a laser disc player.



Antistatic Wrist Strap

Directs you to use an antistatic wrist strap when you perform this procedure.

ULTRIX Workstation Software (UWS) Version 4.2-A is required.

The Multimedia Product Set



Multimedia is a new technology with which you can capture, alter, and present information as still or animated images, and as live, full-motion video with sound. The DECmedia family of products offers the technical advantages of sound and live video at the desktop: information can be captured in real-time, stored locally, and then transmitted over the network to a distant multimedia workstation. Users of Digital Equipment Corporation's RISC workstations can add multimedia hardware, multimedia software development tools to an already integrated computing environment, that provides desktop RISC computing, industry-standard personal productivity tools, and access to distributed applications and resources.

This chapter provides the following information about these multimedia products:

- A description of the TX color frame buffer and DECvideo/PIP modules, a description of the decaudio module and distribution box, see DECmedia Multimedia Products
- A description of the XMedia Tools software, video server, Software Motion Pictures, and audio server software, see XMedia Software
- An overview of TURBOchannel, see TURBOchannel

DECmedia Multimedia Products

DECmedia multimedia hardware consists of three products: the TX color frame buffer, the DECvideo/PIP daughter card for the TX color frame buffer, and a DECAudio module and distribution box. The TX 24-plane color frame buffer provides true color with no graphics acceleration. The DECvideo/PIP module converts the video data to digital format, so that the data can be displayed with computer-generated text and graphics, and captures video

frames one frame at a time. The DECAudio product allows you to receive and transmit sound using microphones, speakers, headsets, headphones, cassette players, VCRs, and more.

TX Color Frame Buffer Features



- Supports 1280-by-1024 monitors, 66Hz (PMAG-J) and 72Hz (PMAGB-J) versions, 8-bit and 24-bit access mode for graphics, and a hardware cursor.
- The TX color frame buffer occupies one TURBOchannel option slot.

DECvideo/PIP Module Features



- Converts video data to digital format so that this data can be displayed with computer-generated text and graphics.
- A daughter card (AVA10U-A) for the TX color frame buffer. It cannot stand alone, it must be used with the TX.
- Accepts live NTSC (640 x 480 pixels) signals at 30 frames per second, PAL or SECAM (768 x 576 pixels) signals at 25 frames per second.
- Input signals: NTSC/PAL/SECAM composite, S-video, RGB
Output signal: RGB.
- Permits scaling of video window from full-size to icon size.
- Permits the use of peripheral devices such as VCRs, VTRs, and laser disc players with your multimedia workstation.
- Permits video data storage (frame grabbing).



DECAudio Module and Distribution Box Features

- A DECAudio signal processing module (AV01B) occupies one TURBOchannel option slot. It provides telephone line and set interfaces for U.S. and Canadian telephone exchanges.
- An external distribution box provides:
 - Speaker, amplification, stereo volume/balance control
 - Microphone, headphone and handset jacks — microphone preamplification for gain flexibility
 - Analog, telephone-quality audio-in and audio-out capabilities (8-bit, 8-KHz sampling)
 - CD-quality audio (dual channel 16 bit, 44.1KHz sampling) on stereo line out
 - ISDN S interface (certification country specific)
 - DSP port

Configuring Multimedia Systems

DECAudio, TX, and DECvideo/PIP hardware can be attached to base systems that support RISC and TURBOchannel interconnect technology. The number of TURBOchannel modules that can be installed varies according to the specific workstation. Some workstations have three TURBOchannel option slots and others have one or two option slots. You select the DECmedia options that best fit your workstation and multimedia applications environment.

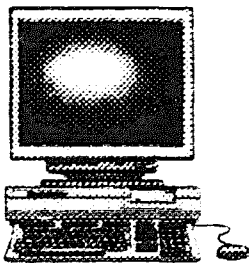


Table 1 shows Digital Equipment Corporation RISC-based workstations, storage requirements, and peripherals suggested for use with DECAudio hardware, TX, and DECvideo/PIP hardware, and with XMedia software.

A multimedia workstation uses the following software:

- ULTRIX Workstation Software (UWS) Version 4.2-A
- Motif Version 1.1 (optional)
- DECwindows Version 2.0
- XMedia Runtime Kit Version 1.0

Table 1 Multimedia Configurations

DECstation 5000	Option Slots¹	Memory	Disk Storage	Peripherals
Models 120, 125 and 133	3	16 MB min. ⁴	1+ GB	RRD42 compact disc drive Headset ³ Laser disc player ² Switchers External speakers Microphones ³ VCR Video camera
Models 200 and 240	3	16 MB min. ⁴	1+ GB	RRD42 compact disc drive Headset ³ Laser disc player ² Switchers External speakers Microphones ³ VCR Video camera
Models 20 and 25 ⁵	2	24 MB min. ⁴	1+ GB	RRD42 compact disc drive Headset ³ Laser disc player ² Switchers External speakers Microphones ³ VCR Video camera

¹TURBOchannel option: slots.

²See the XMedia software documentation, specifically the dxvideoplayer reference page, for the brand and model number of laser disc player recommended for use with XMedia software.

³See Chapter 3, Chapter 4, and Appendix B in this guide when attaching peripherals to your multimedia workstation.

⁴32 MB of memory is suggested for video applications.

⁵Contains built-in audio. Audio functionality is not supported in Version 1.0 of XMedia software.

XMedia Software

XMedia software is the ULTRIX multimedia audio and video enabling software for RISC-based DECstation 5000 workstations. This software will assist software developers in creating multimedia end-user applications and in enhancing existing applications using the DECmedia audio and video hardware components.

Xmedia software consists of two products: an audio/video Runtime Kit and an audio/video Developers Kit.

- The XMedia Runtime Kit provides the runtime multimedia software, the audio server, audio and video drivers, Software Motion Pictures player, sample applications, and audio and video clips. The license(s) for this kit is included with the DECAudio and DECvideo/PIP products.
- The XMedia Developers Kit includes the contents of the Runtime Kit and adds additional tools such as example applications, Software Motion Picture builder, and online programmer documentation. A larger selection of audio and video clips is available to developers as part of the Developers Kit.

See the *XMedia Concepts Guide*, order number QA-MB4AA-GZ, for an overview of the XMedia software products.

Video Server Software — X Window System Video Extension

The X Window System Video Extension (Xv) software supports current interactive video technology. This extension uses as a model the video capabilities of the X Window System. Requests to display video from an adapter in a drawable are modeled after the core PutImage request, though extended to support scaling and source clipping.

Software Motion Pictures Video Compression and Display Software

Software Motion Pictures is an affordable compression and decompression solution for displaying animated sequences on X Window System-based workstations. It is an inexpensive substitute for video in situations that require digitized video but do not warrant specialized hardware.

Like other digital video compression processes, Software Motion Pictures compression and decompression are asymmetric processes. Compression is a fairly computation-intensive off-line operation, while decompression occurs quickly enough to provide smooth replay of video sequences. Unlike other digital video schemes, Software Motion Pictures compression implements all of these operations completely in software.

A utility called `dxgrabframes` allows you to capture frames from DECvideo/PIP hardware, compress these frames into `.img` format, and store the frames as a Software Motion Pictures clip. The resulting Software Motion Pictures clip can be decompressed (in real time, 12 to 15 frames per second) and played back on the workstation monitor. Software Motion Pictures uses software exclusively for both video compression and decompression. Video compression is a non-real-time process with typical compression rates of four to eight frames per minute on a DECstation 5000-series workstation. Decompression is performed at a speed that supports smooth, jerk-free frame rates on DECstation 5000-series workstations with TX frame buffers.

Software Motion Pictures displays on 8- and 24-bit workstations and can automatically adapt to the available colors on the screen (real-time dithering). It supports real-time controls for brightness and contrast.

Audio Server Software

The purpose of the audio server is to:

- Provide a device abstraction that allows for the easy creation and maintenance of device-independent audio applications
- Provide management and mechanisms for sharing audio resources
- Provide for network-transparent access to audio resources
- Offer clients synchronized access to multiple audio devices
- Allow for client-side synchronization of audio playback with other forms of media. A speaker and player are needed.
- Implement each of the core device classes: input devices, output devices, players, recorders, telephone interfaces, mixers, crossbar switches, DSPs, echo cancellation, speech recognition, music synthesizers, and text-to-speech devices.

Most devices will be implemented by software algorithms and digital audio hardware contained in a workstation. Outboard analog devices are allowed, but are not central to the design of the product. The server is designed so that simple audio cues are easy to use. The server is flexible enough so that complex audio setups can be constructed and synchronized during use.

TURBOchannel

TURBOchannel is a low-cost, high-performance module interconnection technology based on hardware, software, and firmware components. At the core of the TURBOchannel hardware is a synchronous asymmetrical I/O channel used to connect option modules to a workstation system module. The channel is asymmetrical in that the system module has read or write access to an option module, and an option module has read or write access to the system module. Option modules have no access to other option modules.

TURBOchannel Modules

TURBOchannel modules vary in width and can occupy more than one option slot—all TURBOchannel modules have similar shapes and connectors. One or more connectors on the bottom of the module attach the module to the base system. One end of a TURBOchannel module has a connector that allows the module to connect to an external device. DECAudio and DECvideo modules follow the same design characteristics.

Page 8 is a blank page

DECAudio Installation



This chapter provides the following information about installing DECAudio hardware in your workstation:

- Unpacking DECAudio Hardware
- Installing the DECAudio Module
- Connecting Cables to the DECAudio Module
- Checking the Configuration Display
- Diagnosing and Solving Problems

The DECAudio multimedia product consists of the following hardware:

- An audio module that occupies one TURBOchannel option slot
- A distribution box, power supply, power cable and stand.

The distribution box provides hardware connections for:

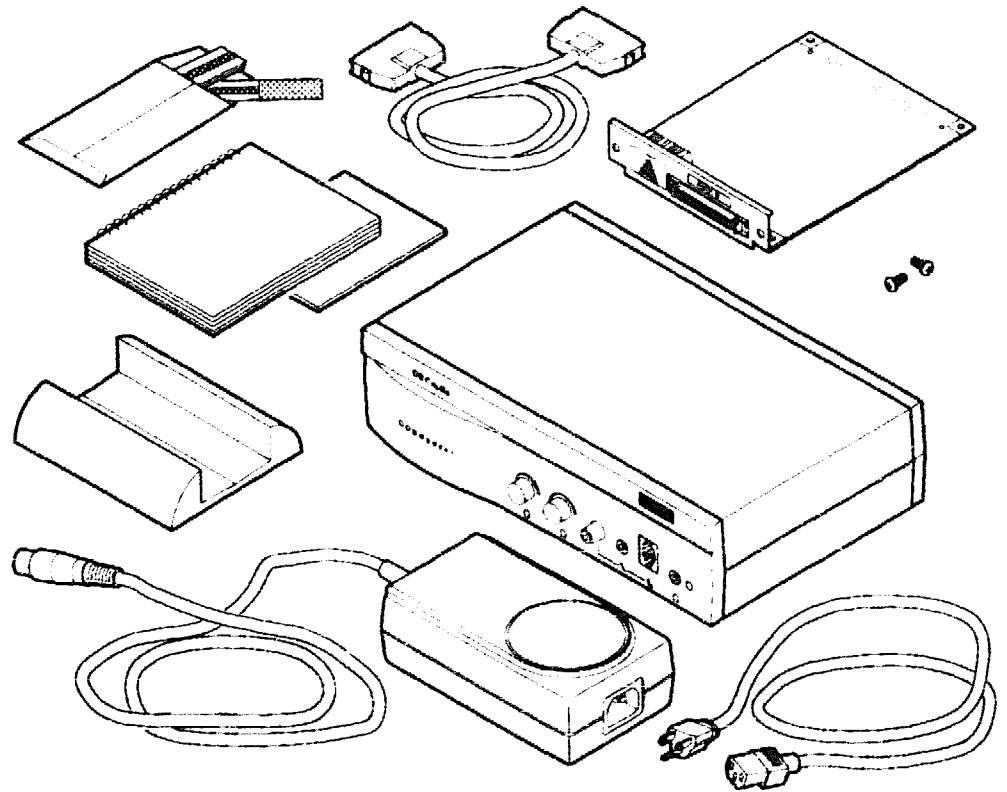
- Headphones
- Headset or handset
- Microphone
- Speakers

Unpacking DECAudio Hardware

The DECAudio parts kit (see Figure 1) contains the following items:

- Disposable antistatic wrist strap
- Distribution cable, 60-pin to 60-pin connectors, 2 meters in length
- DECAudio TURBOchannel module
- *DECmedia User's Guide*
- *DECAudio Installation* booklet
- Two Phillips screws
- Stand for vertical mounting of DECAudio distribution box
- DECAudio distribution box
- DECAudio power supply, auto-sensing and switchable between 50Hz and 60Hz, and 120 or 240 volts.
- The U.S. kit includes an AC power cable, 6-foot in length, to connect the power supply to a 50Hz or 60Hz power source. Other countries must order a power cord.

Figure 1 Contents of DECAudio Option Package



Label each cable as you remove it from the shipping carton. Multimedia applications use numerous peripheral devices in addition to the DECAudio module and distribution box; each device will have its own cabling requirements. A simple label identifying each item in your multimedia configuration will make easy any future move or equipment change.

Installing the DEAudio Module

This section provides instructions for installing a DEAudio module into your system unit and includes the following steps (explained below):

1. Shutting down the workstation software
2. Removing the system unit cover
3. Attaching an antistatic wrist strap
4. Removing the options slot cover
5. Installing the module
6. Replacing the system unit cover
7. Turning on your system

Shutting Down the Workstation Software

Before you turn off a system, read your operating system documentation for proper shutdown procedures:

- Turn off the system unit by pressing the O on the on/off switch on the back of the system unit.



Warning

Leaving the system turned on could cause electrical shock to you and severe damage to your computer or to a module.

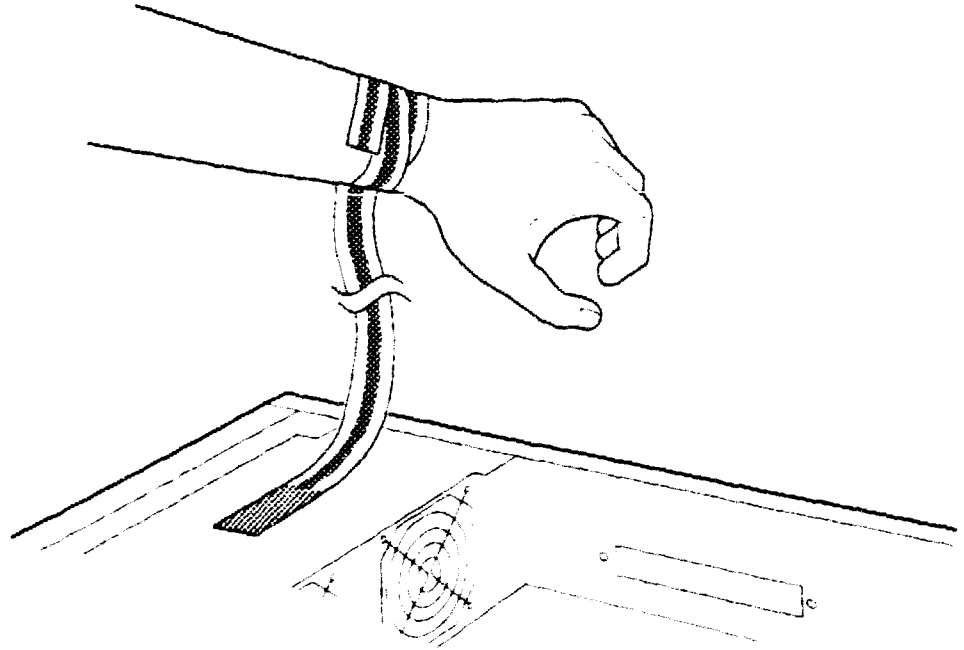
Removing the System Unit Cover

Locate your workstation operator's guide or user's guide. Refer to the section that describes how to add options to your system. This section contains the proper instructions for removing a system unit cover. Follow these instructions to remove the cover.

Attaching an Antistatic Wrist Strap

Before you touch anything inside the system unit or remove any static-sensitive item from an antistatic bag, attach the antistatic wrist strap to your wrist and to an unpainted metal surface such as the power supply. (See Figure 2.)

Figure 2 Attaching Antistatic Strap



Always wear an antistatic wrist strap when handling a module.
Read the instructions on the envelope.

Caution

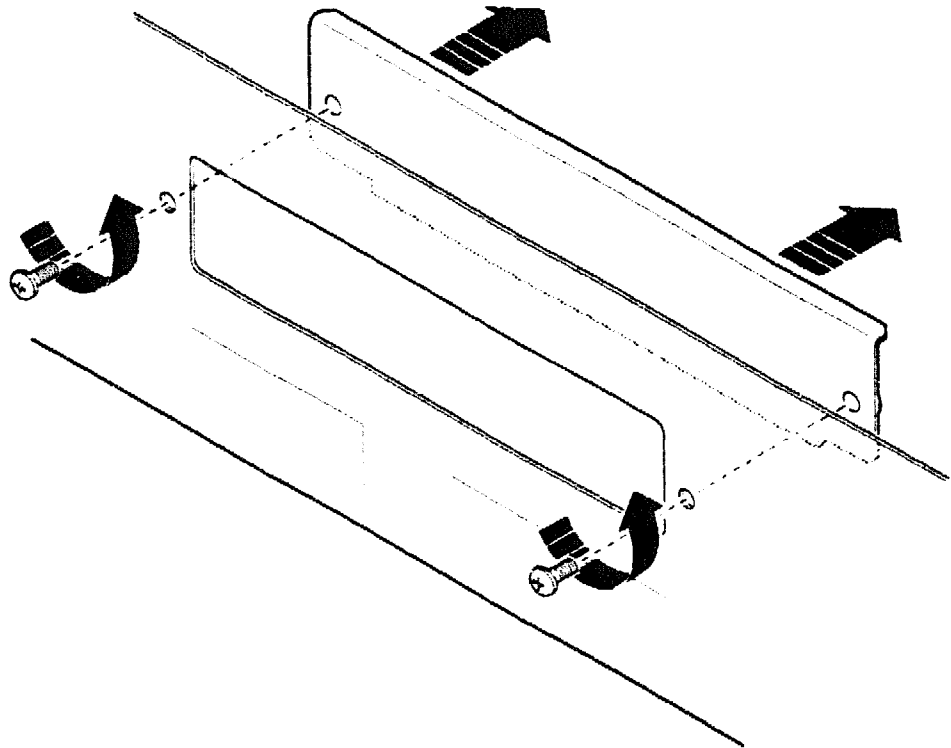
Failure to take antistatic precautions may cause damage
to a module from static discharge.

Removing the Options Slot Cover

Remove the metal cover from any available option slot.

1. Remove the two screws that hold the cover in place.
2. Remove the cover and set it aside. (See Figure 3.)
3. Set the screws aside; you need them to secure the DECAudio module to the system unit bulkhead. Save the cover. You will need to replace the cover (to keep your system FCC compliant) if you ever remove the DECAudio module from the system unit without reinstalling it or replacing it.

Figure 3 Removing the Options Slot Cover



Installing the Module

You may find that one of the TURBOchannel option slots is already filled; for example, it may already contain a TX color frame buffer. If so, select an open slot.

Complete the following steps to install your DECAudio module:

1. Position the DECAudio module so that the slot connector faces down, and the cable connector slides through the option slot opening. (See Figure 4.)

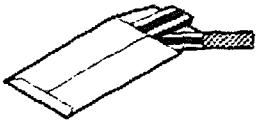
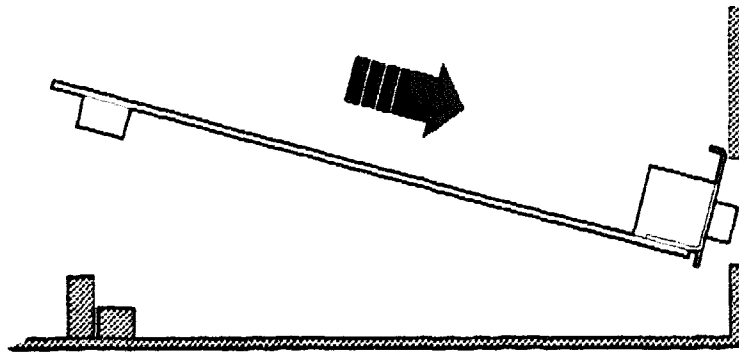


Figure 4 Inserting a DECAudio Module into TURBOchannel Option Slot



2. Move the DECAudio module so that the cable connector passes through the TURBOchannel option slot opening, and is visible on the back of the system unit.

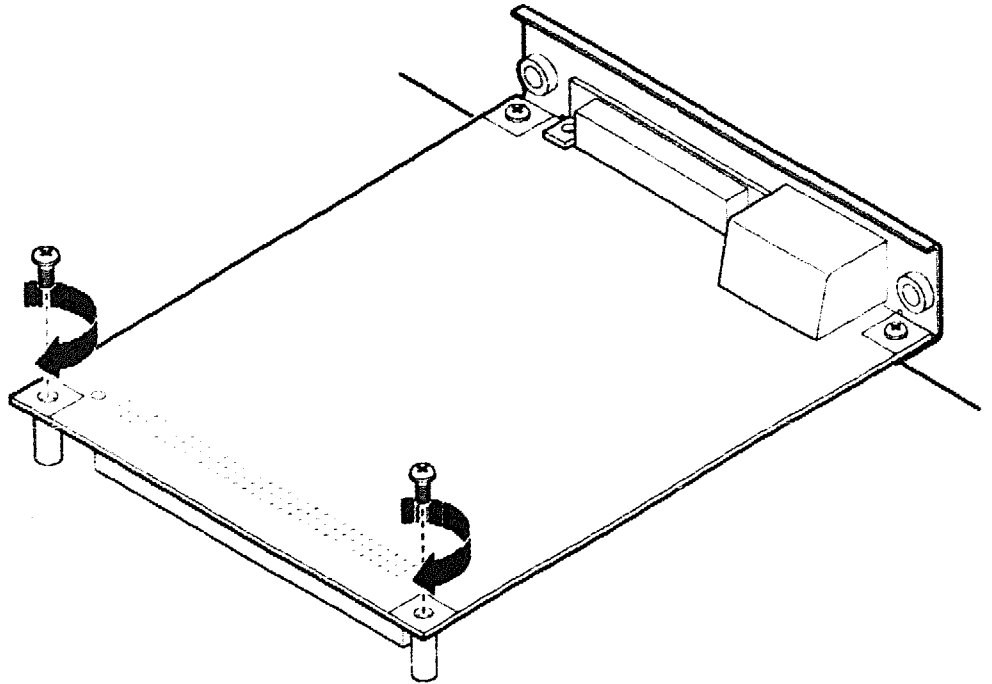
3. Firmly push the slot connector onto the system board support posts, so that the module is parallel to the bottom of the system unit. (See Figure 5.)

Figure 5 Pushing Module onto Support Posts



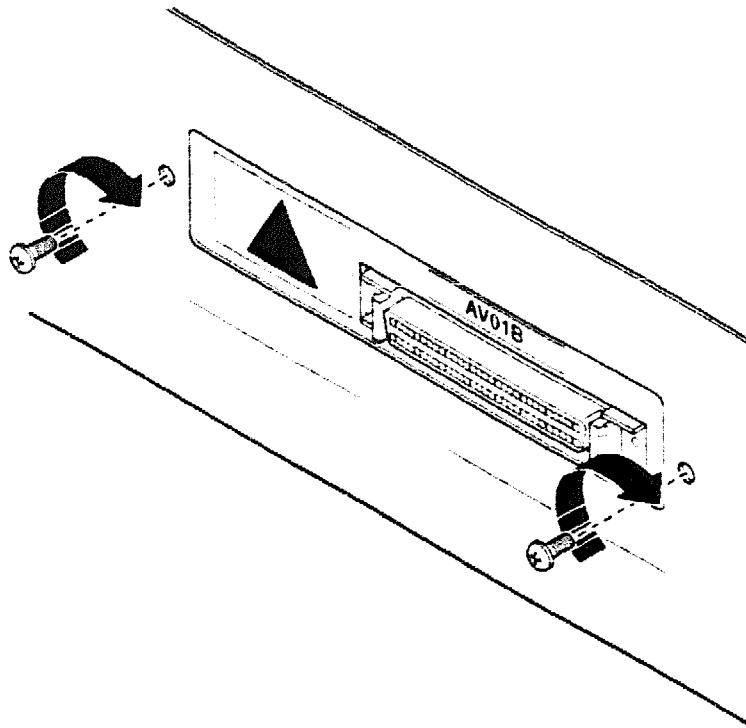
4. Locate the two screws that came in the parts kit.
5. Insert one screw into each support post hole and secure the module. (See Figure 6.)

Figure 6 Securing Module to TURBOchannel



6. Use the two screws (see Figure 3) that held the metal cover over the option slot to secure the module against the back of the system unit. (See Figure 7.)

Figure 7 Securing Module to System Unit



7. If you plan to add the TX and/or DECvideo/PIP modules, skip to Chapter 3 to install these options. Otherwise, continue with the installation instructions in this chapter.

Replacing the System Unit Cover

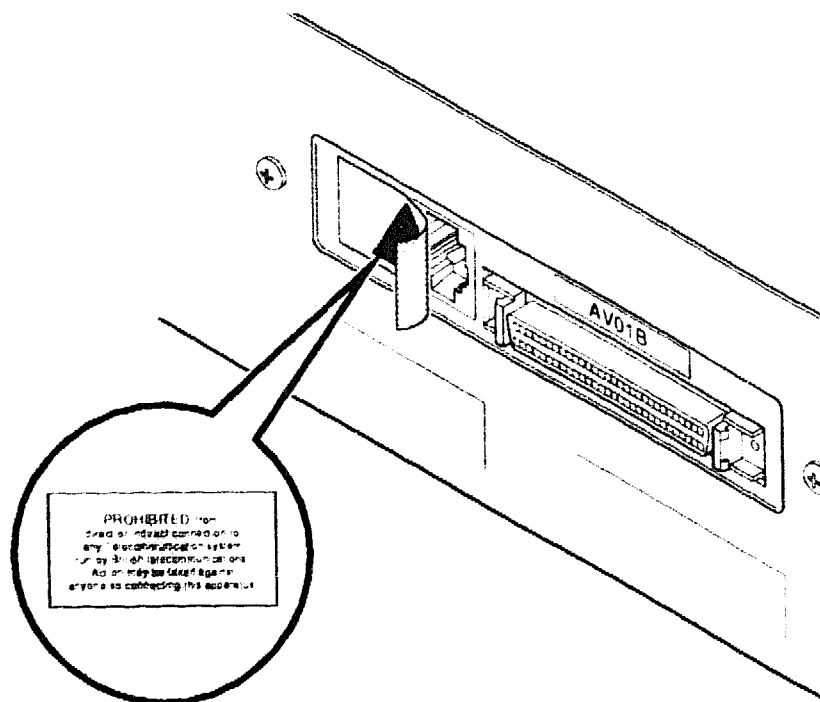
- Remove the wrist strap.
- Follow the instructions in your workstation operator's guide, and replace the system unit cover.



Connecting Cables to the DEAudio Module

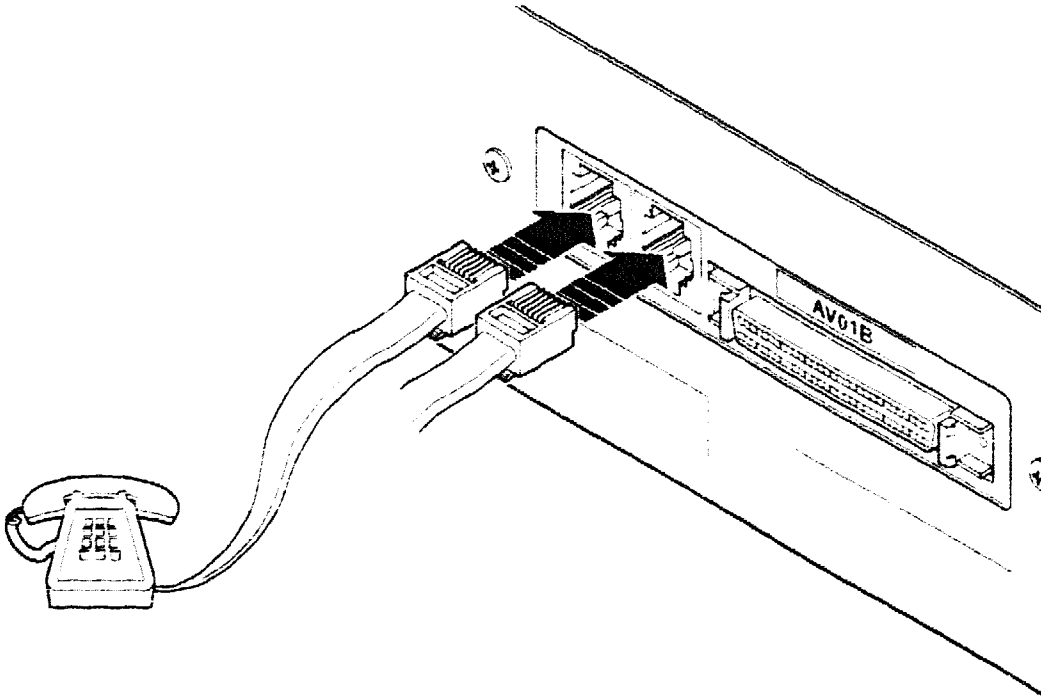
United States and Canadian customers can use the telephone set and telephone line jacks behind the label with the red triangle. These customers should peel off the label and expose the set and line connections to the Public Switched Telephone Network (PSTN). (See Figure 8.)

Figure 8 Removing the Label



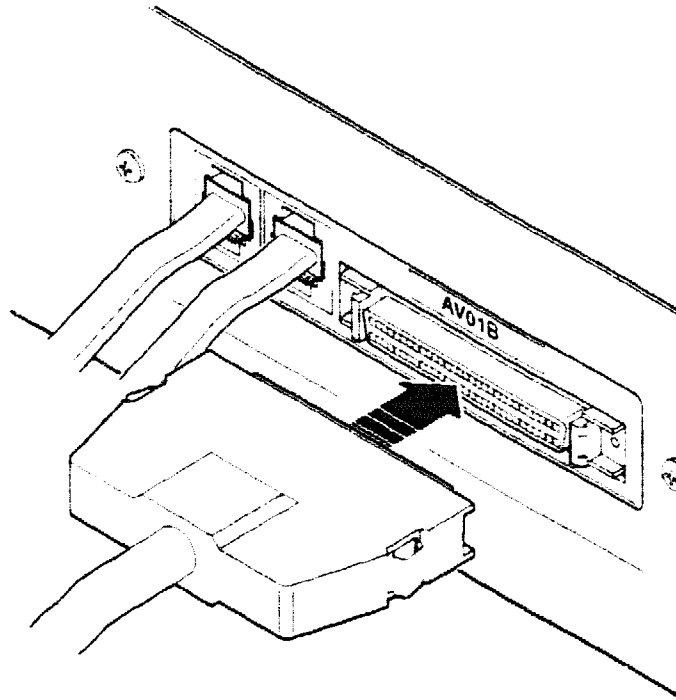
- Plug your telephone into the left (set) jack. Plug the telephone line from the Public Switched Telephone Network (PSTN) into the right (line) jack. (See Figure 9.)

Figure 9 Connecting a Telephone and Telephone Line



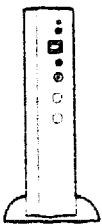
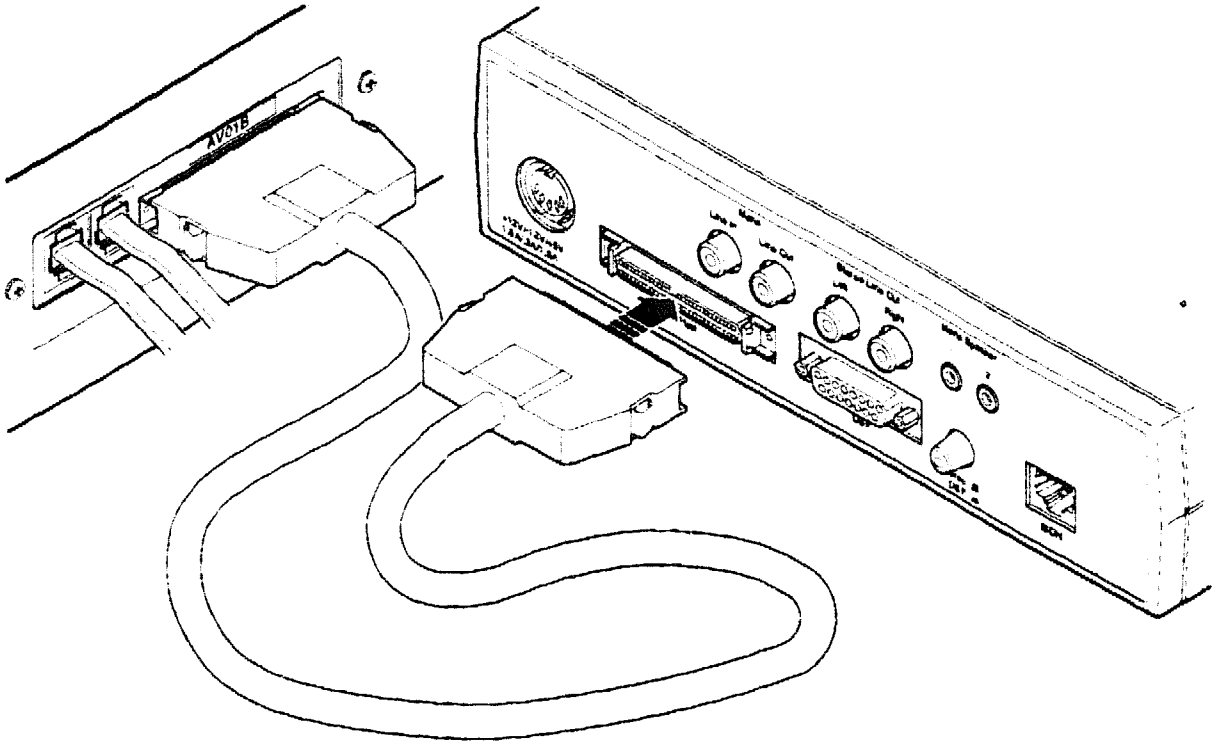
- Plug the DECAudio distribution cable into the DECAudio module connector on the back of the system unit. (See Figure 10.)

Figure 10 Connecting Distribution Cable



- Connect the other end of the cable to the distribution box.
(See Figure 11.)

Figure 11 Distribution Cable Connectors



The DECAudio distribution box (see Figure 12) contains a speaker and the following features:

1. Balance control for stereo headphones.
Not supported in Version 1.0 of XMedia software.
2. Volume control for stereo headphones.
Not supported in Version 1.0 of XMedia software.
3. Mute switch. LED is green when the mute is not engaged.



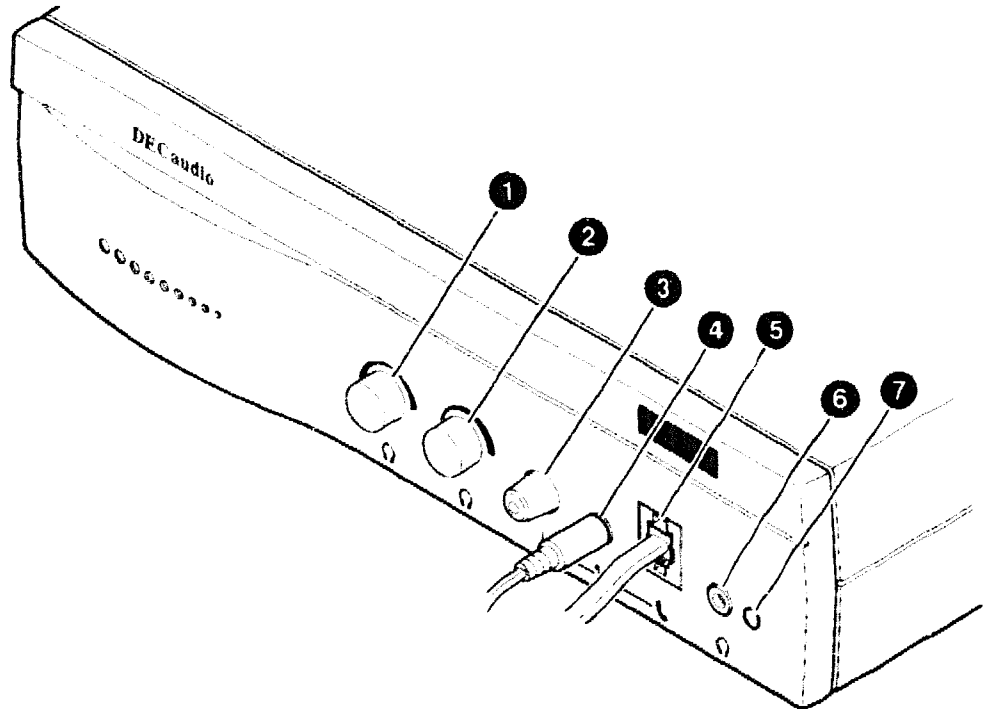
4. Mini 3.5-mm (1/8-inch) jack for a microphone.

A microphone can be used in parallel with handset input; that is, you can use the microphone for audio input and the handset for audio output. See the next section and Appendix B for additional information.

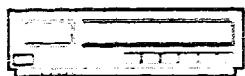
5. Telephone jack for a headset or handset.
6. Mini 3.5-mm (1/8-inch) jack for a stereo headphone.
Not supported in Version 1.0 of XMedia software.
7. Power indicator. LED is green when power is on.



Figure 12 DECAudio Distribution Box (Front View)



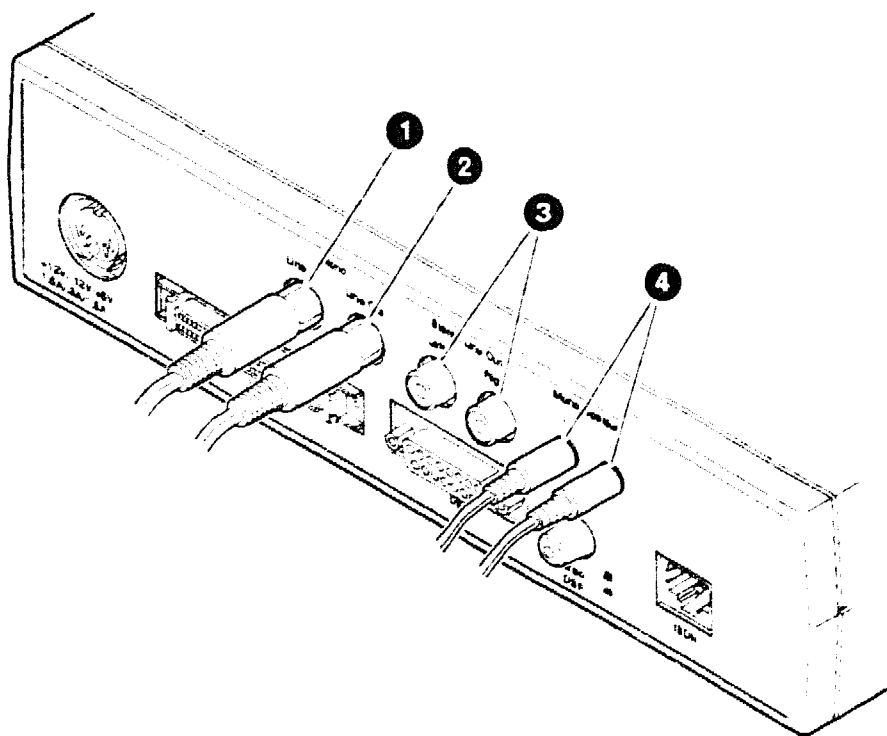
- Connect cables to the back of the distribution box as needed. (See Figure 13 and Figure 14.)



1. Mono Line In. Connect an RCA phono plug to this jack. Use with monaural voice-quality input signals from a source such as a VCR or cassette player.
2. Mono Line Out. Connect an RCA phono plug to this jack. Use with monaural voice-quality output signals for input to devices such as an external amplifier, stereo receiver, or cassette player.
3. Stereo Line Out left and right.
Not supported in Version 1.0 of XMedia software.
4. Mono Speaker 1 and 2. Connect mini plugs to these 3.5-mm (1/8-inch) jacks. Use with monaural voice-quality output signals to devices such as headphones or speaker.

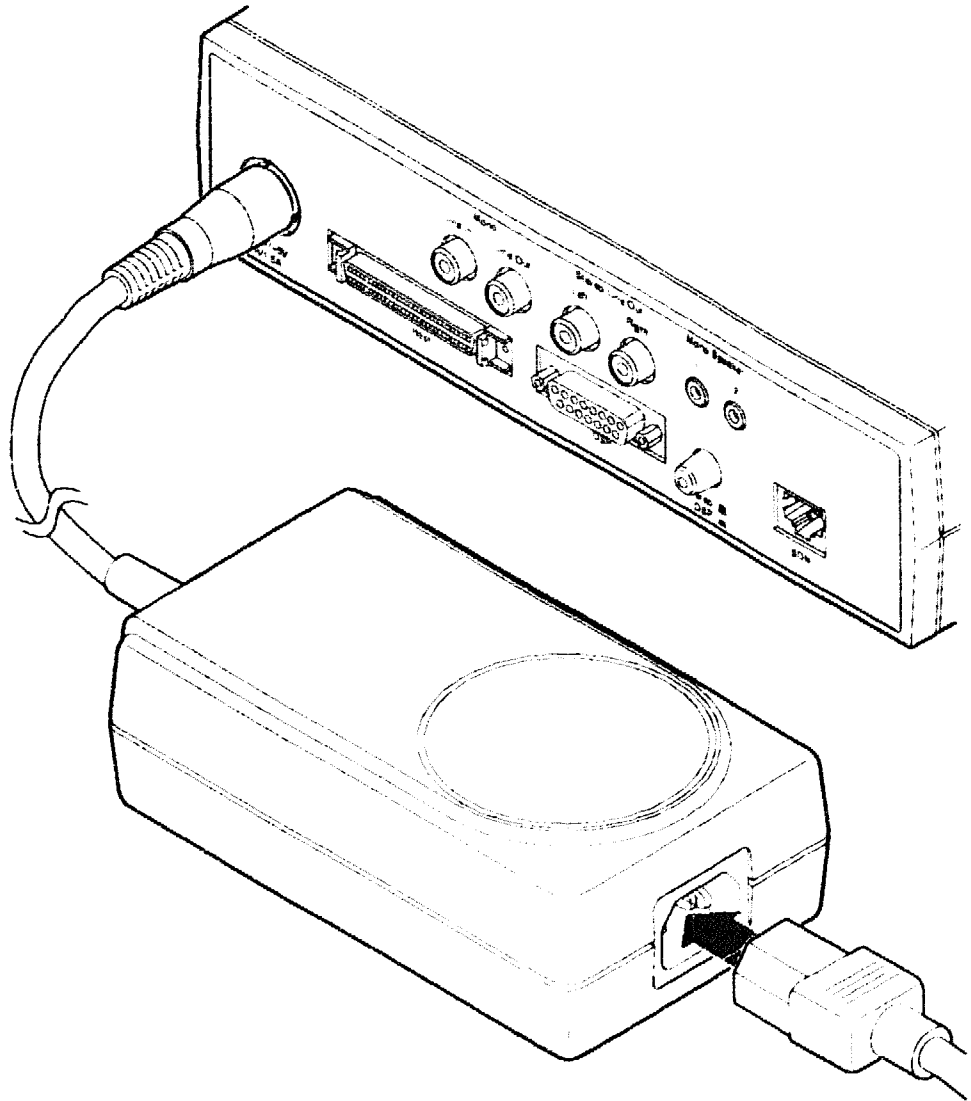


Figure 13 DEAudio Distribution Box (Back View)



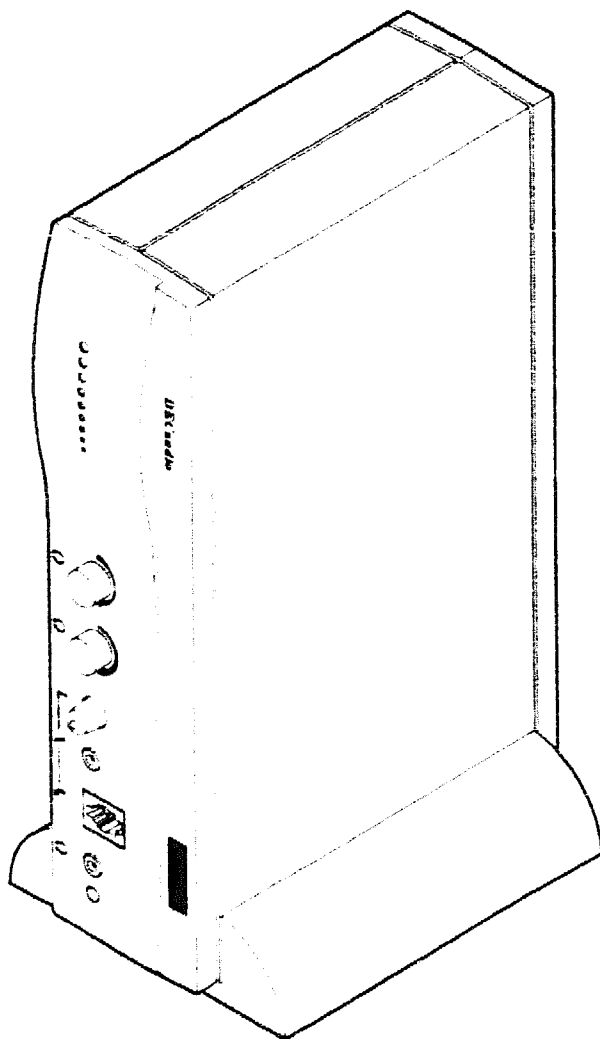
- Connect the power supply to a power source. (See Figure 15.)

Figure 15 Power Supply



To save space on your desk top, use the stand provided in your parts kit. For a secure fit, slide the stand into the parting lines on the distribution box. (See Figure 16.)

Figure 16 Stand






Using Microphones

The DECAudio product is capable of adjusting the internal amplifier gain over a +/-18 dB range by means of software control. This capability permits you to use a wide range of microphone types, including cermet and dynamic microphones. To work properly with the DECAudio product, a microphone should meet the following specifications:

- A sensitivity specification between -44 and -71 dBV (the dBV number is the open-circuit output voltage relative to 1 V at an input pressure of 1 uBar). This sensitivity range assumes that you hold the microphone 6 inches from your mouth while speaking at a normal level.
- An output resistance less than 1K ohms.
- A 3.5mm (1/8-inch) mini phone plug. A 1/4-inch phone plug can also be used with an appropriate adapter.

The intensity of a microphone's output signal depends on how loud a user speaks and how the microphone is positioned. The +/- dB gain adjustment range accommodates most preference ranges.

Turning On Your System



To start your system, press the (|) on the on/off switch for the monitor. Next, press the (|) on the on/off switch on the back of the system unit.

Checking the Configuration Display

To check for proper installation of the module, run the configuration test, which displays configuration data about the system.

To run the configuration test, type `cnfg` at the console prompt (`>>`) and press `Return`. A display similar to the following appears on the screen.

```
>>cnfg
7: KN02-AA DEC V5.3c TCF0 ( 8 MB)
6: PMAD-AA DEC V5.3a TCF0 (enet: 08-00-2b-1b-c6-fb)
5: PMAZ-AA DEC V5.3b TCF0 (scsi = 7)
1: AV01B-AA DEC V1.24 TCF0 (DECAudio)
>>
```

The display identifies the modules in two ways:

- By ID (or part) number
- By the number of the system unit slot that contains the module

The number that begins each line of the configuration display is the number of a base slot or of an option slot that contains a module. Lines that begin with 0:, 1:, and 2: indicate option slots that contain a TURBOchannel option module. A slot that does not contain a module does not show up in the configuration display.

The information inside the parentheses at the end of each display line identifies the module present in that slot. In the above display, the DECAudio module AV01B-AA is present in option slot 1.

Systems configured for autoboot will not display a console prompt. Console commands cannot be used with autoboot configured.

Diagnosing and Solving Problems

ROM-based diagnostics run every time the system is turned on and every time the system is reset. These diagnostics verify that the DECAudio module is functioning properly. Three tests can be used to diagnose problems:

Quick Power-Up Test

The `pst-q` power-up test is a quick test (about 5 seconds in length) that checks the functionality of the DECAudio module. Use this test after you turn on your system for the first time, or when your system is reset (operating system is not running). When the power-up has completed successfully, the console prompt (`>>`) appears on the screen.

Optionally, the test can be invoked at a console by an operator using the `sh` command. To run the test, type `sh #/pst-q` at the console prompt (`>>`) and press `Return`. Replace the `#` in the example with the number of the option slot number containing the DECAudio module.

Systems configured for autoboot will not display a console prompt. Console diagnostics cannot be used with autoboot configured.

Telephone Set and Line Test

The `tli` telephone set and line test checks the functionality of the DECAudio telephone line interface.

To run this test, plug a telephone into the left (set) jack, and plug the telephone line from the Public Switched Telephone Network (PSTN) into the right (line) jack on the DECAudio module. (See Figure 9.) Type `t #/tli` at the console prompt `>>` and press `Return`. Replace the `#` in the example with the number of the option slot number containing the DECAudio module. The following is displayed:

```
>> t #/tli
      START : DECAudio Telephone Line Interface Test
             Please call Phone line connected to DECAudio
```

Place a telephone call (from another telephone) to the telephone you just connected to the set jack on the DECAudio module. The following message is displayed:

DECAudio has detected Ringing Tones.
Phone is OFF HOOK.
Phone (if connected to SET) should stop ringing.
Please punch in Touch-tone numbers and Verify (12 maximum)
Touch-tone keys are ...

Press 12 telephone keypad numbers and verify their entry on the screen display:

Phone is ON HOOK.
END : DECAudio Telephone Line Interface Test Passed.

Replace the DECAudio module if your equipment does not pass the test.

Thorough Power-Up Test

The `pst-t` power-up test is a more thorough test (about one minute in length) that verifies the functionality of the DECAudio module. To run this test, remove the cables to the line and set connectors on the DECAudio module. This test can also be invoked at a console by an operator using the `sh` command. When the power-up has completed successfully, the console prompt (`>>`) appears on the screen. To run this test, type `sh #/pst-t` at the console prompt (`>>`) and press **Return**. Replace the `#` with the number of the option slot number containing the DECAudio module.

Systems configured for autoboot will not display a console prompt. Console diagnostics cannot be used with autoboot configured.

If either of the tests do not complete successfully, error messages are displayed. Error messages, when generated, take the following form:

```
? TFL #/test-name(misc.info) [module]
```

Each field in the above error message example is explained as follows:

- `#` indicates the TURBOchannel option slot number
- test name is the name of the test that generated the message
- misc. info is replaced by a string of optional information that may include the number of the failed address, or may include an explicit description of the failure.
- `[module]` is the name of the processor. For example, the module name for the DECstation 5000 Model 200 is `[KN02-AA]`.

Table 2 explains the mnemonics used in TURBOchannel error messages. Refer to your operator's guide for additional information.

Table 2 Mnemonics In TURBOchannel Error Messages

Mnemonic	Description
DEV	Invalid device specification
EV	Invalid environment variable
EVV	Improper environment variable value
FNF	File not found
IO/Input	Output error
NUM	Invalid numeric argument
SEC	Security error
SNF	Script not found
STX	Syntax error
TFL	Diagnostics test failure
TNF	Test not found
TXT	Object is not a text object
UIM	Unimplemented

Equipment Return Information

If the DECAudio diagnostics return an error message, then proceed as follows:

- If your DECmedia equipment is under a service contract or is still in warranty, then report the problem to your local Digital service representative.
- If however, you purchased your DECmedia equipment at list price, then call your Digital sales representative.

Defective parts may also be returned to your local Digital Field Service Repair Center.

TX and DECvideo/PIP Installation

This chapter provides information about installing the TX and DECvideo/PIP hardware products in your workstation:

- Unpacking TX Hardware
- Installing the TX Module
- Unpacking DECvideo/PIP Hardware
- Installing the DECvideo/PIP Module
- Connecting Cables
- Checking a TX Configuration
- Diagnosing and Solving Problems

The TX and DECvideo/PIP multimedia products consist of the following hardware:

- A two-board TX module
- A DECvideo/PIP module
- Monitor cable and video input cable

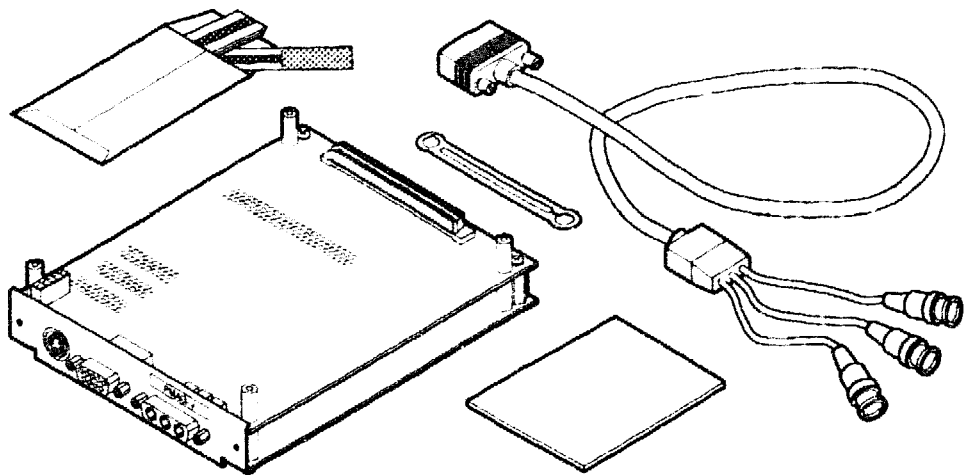
Unpacking TX Hardware



The TX parts kit (see Figure 17) contains the following items:

- Disposable antistatic wrist strap
- Monitor video cable
- Strain relief strap
- TX module: either the 66 Hz (PMAG-J) model or the 72 Hz (PMAGB-J) model
- *DECvideo Installation* booklet

Figure 17 Contents of TX Option Packages



Label each cable as you remove it from the shipping carton. Multimedia applications use numerous peripheral devices in addition to the TX color frame buffer; each device will have its own cabling requirements. A simple label identifying each item in your multimedia configuration will make easy any future move or equipment change.

Installing the TX Module

This section provides instructions for installing the TX module into your system unit and includes the following steps (explained below):

1. Shutting down the workstation software
2. Removing the system unit cover
3. Attaching an antistatic wrist strap
4. Removing the options slot cover
5. Removing an existing module
6. Installing the TX color frame buffer
7. Replacing the system unit cover
8. Turning on your system

Shutting Down the Workstation Software

Before turning off your system, read your operating system documentation for proper shutdown procedures.

- Turn off the system unit by pressing the O on the on/off switch on the back of the system unit.



Warning

Leaving the system turned on could cause electrical shock to you and severe damage to your computer or to a module.

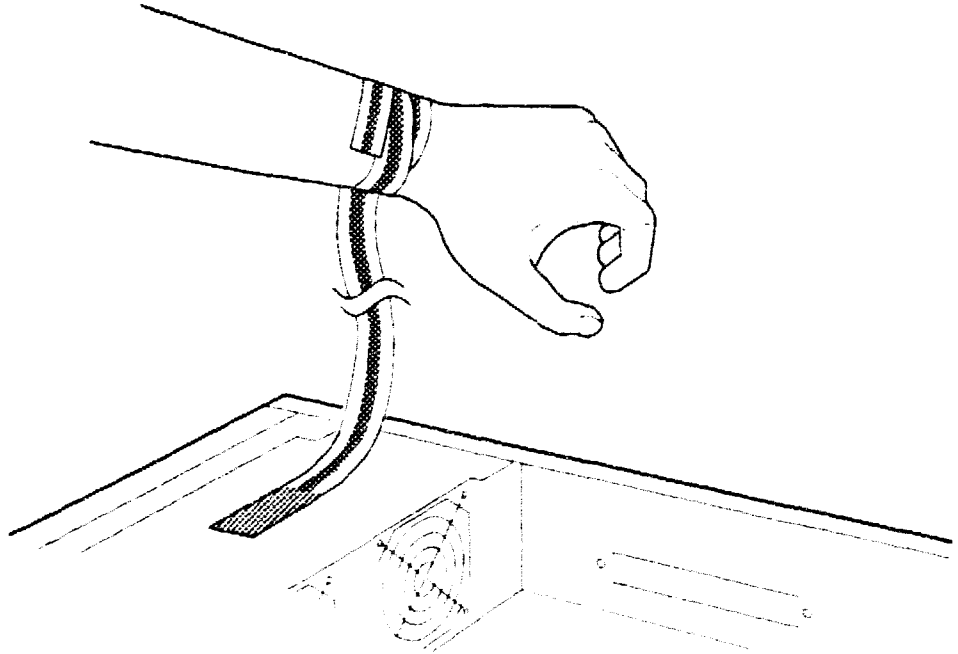
Removing the System Unit Cover

Locate your workstation operator's guide or user's guide. Refer to the section that describes how to add options to your system. This section contains the proper instructions for removing a system unit cover. Follow the instructions in your workstation operator's guide to remove the cover.

Attaching an Antistatic Wrist Strap

Before you touch anything inside the system unit or remove any static-sensitive item from an antistatic bag, attach the antistatic wrist strap to your wrist and to an unpainted metal surface such as the power supply. (See Figure 18.)

Figure 18 Attaching Antistatic Strap



Always wear an antistatic wrist strap when handling a module.
Read the instructions on the envelope.

Caution

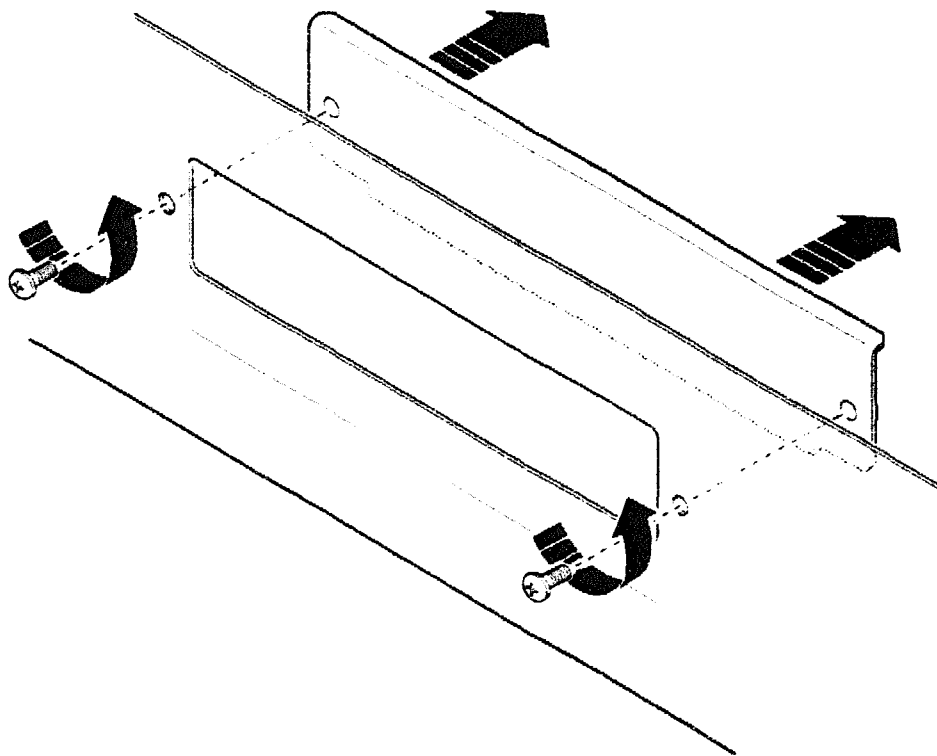
Failure to take antistatic precautions may cause damage
to a module from static discharge.

Removing the Options Slot Cover

Remove the metal cover from any available option slot.

1. Remove the two screws that hold the cover in place.
2. Remove the cover and set it aside. (See Figure 19.)
3. Set the screws aside; you need them to secure the TX module to the system unit bulkhead. Save the cover. You will need to replace the cover (to keep your system FCC compliant) if you ever remove the TX module from the system unit without reinstalling it or replacing it.

Figure 19 Removing the Options Slot Cover



Removing an Existing Module

To remove an existing color frame buffer or graphics module, complete the following steps:

1. Turn off your system.
2. Wait five minutes after powering down before you remove an existing color frame buffer or graphics module. This allows the power supply to discharge any stored voltage.
3. Refer to your workstation operator's guide for instructions on removing a color frame buffer or graphics module. Multiple modules may exist.
4. Remove the module from the system unit. (See Figure 20 and Figure 21.)

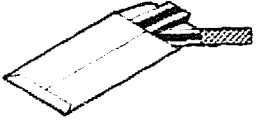
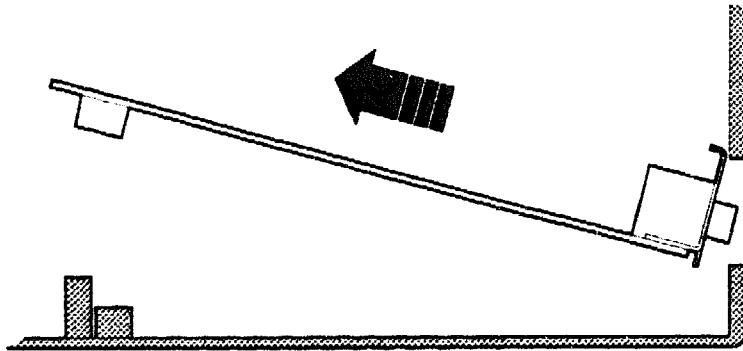


Figure 20 Lifting the Board Away from Support Posts



Figure 21 Sliding the Frame Buffer Out of Option Slot Opening



5. Place the module on an antistatic surface. The module may be used in another like system, and protecting it with antistatic measures will prolong its usable life.

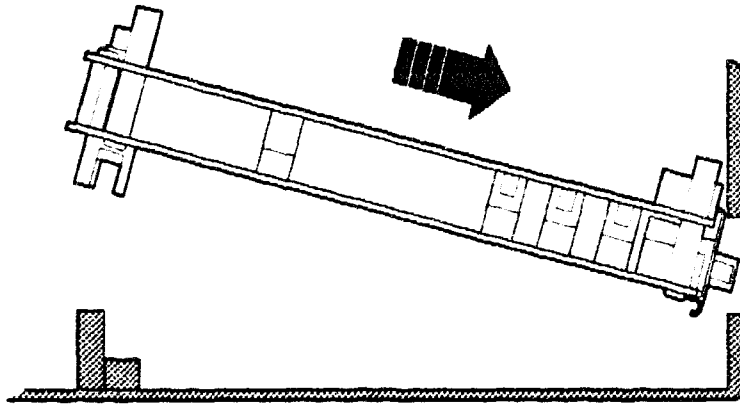
Installing the TX Color Frame Buffer

The TX color frame buffer can be installed in any available TURBOchannel option slot. Complete the following steps to install TX color frame buffer:

1. Position the TX module with its cable connector facing the option slot opening in the back of the system unit, and its TURBOchannel slot connector facing down. (See Figure 22.)



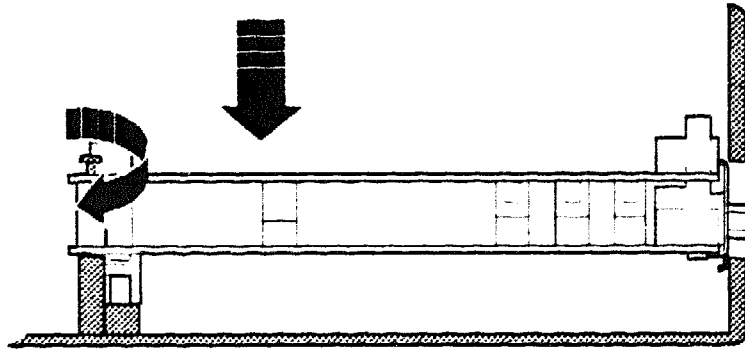
Figure 22 Inserting the TX Color Frame Buffer



2. Move the TX module so that the cable connector passes through the TURBOchannel option slot opening, and is visible on the back of the system unit.

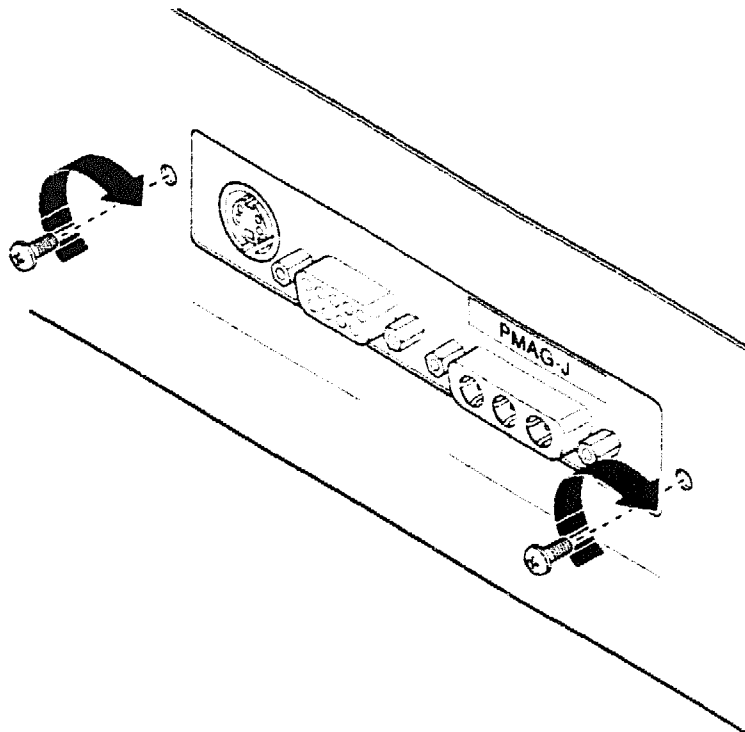
3. Firmly push the system unit slot connector onto the support posts, so that the module is parallel to the bottom of the system unit. (See Figure 23.)
4. Secure the TX module in the TURBOchannel slot by turning each screw to the right until the module is held firmly in place.

Figure 23 Pushing the Module onto Support Posts



5. Locate the two screws that held the metal cover over the TURBOchannel option slot.
6. Secure the TX module in place against the back of the system unit, by turning each screw to your right until the module is held firmly in place. (See Figure 24.)

Figure 24 Securing the TX Module





Replacing the System Unit Cover

- Remove the wrist strap.
- Follow the instructions in your workstation operator's guide and replace the system unit cover.

Turning On Your System

To start your system, press the (|) on the on/off switch for the monitor. Next, press the (|) on the on/off switch on the back of the system unit.



What To Do Next

Table 3 helps you decide what you should do next.

Table 3 Next Step

If	Then
You plan to use a TX color frame buffer.	Skip the next section entitled Unpacking DECvideo/PIP Hardware and follow the instructions for connecting a monitor cable in the section entitled Connecting Cables.
You have the TX color frame buffer installed. You plan to add the DECvideo/PIP module.	Follow the instructions in the next section Unpacking DECvideo/PIP Hardware, and continue with the instructions for connecting the monitor cable and the video input cable in the section entitled Connecting Cables.

Unpacking DECvideo/PIP Hardware

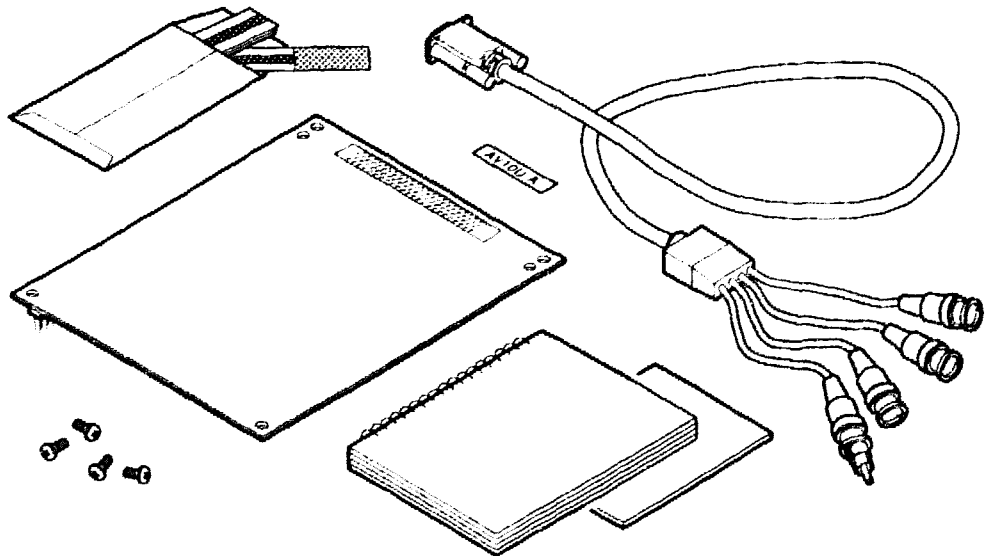


The DECvideo/PIP module is added to the TX module to provide a live picture-in-a-picture (PIP) window. The TX color frame buffer module with the DECvideo/PIP module attached may be installed in any available TURBOchannel option slot.

Your DECvideo/PIP parts kit (see Figure 25) contains the following items:

- Disposable antistatic wrist strap
- Video input cable with attached BNC-to-RCA phono plug adapter
- DECvideo/PIP module
- Four screws
- AV10U label
- *DECvideo Installation* booklet
- *DECmedia User's Guide*

Figure 25 Contents of DECvideo/PIP Option



Label each cable as you remove it from the shipping carton. Multimedia applications use numerous peripheral devices in addition to the DECvideo/PIP module; each device will have its

Label each cable as you remove it from the shipping carton. Multimedia applications use numerous peripheral devices in addition to the DECvideo/PIP module; each device will have its own cabling requirements. A simple label identifying each item in your multimedia configuration will make easy any future move or equipment change.

Installing the DECvideo/PIP Module

This section provides instructions for installing the DECvideo/PIP module into your system unit and includes the following steps (explained below):

1. Shutting down the workstation software
2. Removing the system unit cover
3. Attaching an antistatic wrist strap
4. Adding the AV10U Label
5. Adding the DECvideo/PIP module to the TX Module
6. Replacing the system unit cover
7. Connecting peripherals
8. Turning on your system

Shutting Down the Workstation Software

Before you turn off a system that has been running, read your operating system documentation for proper shutdown procedures.

Complete the following step:

1. Turn off the system unit by pressing the O on the on/off switch on the back of the system unit.

Removing the System Unit Cover

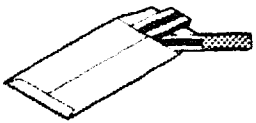
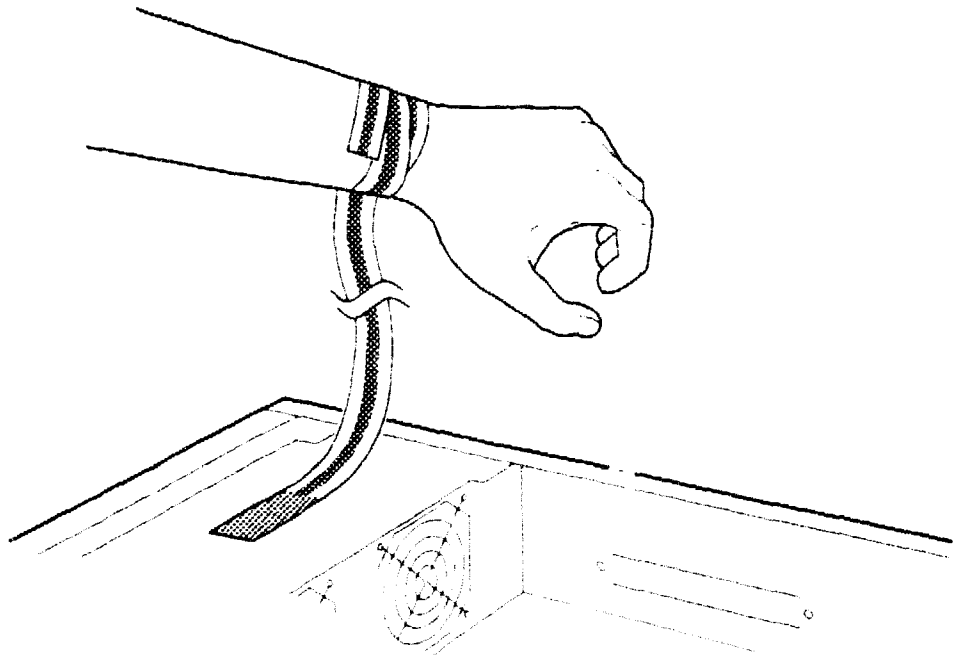
Locate your workstation operator's guide or user's guide. Refer to the section that describes how to add options to your system. This section contains the proper instructions for removing a system unit cover. Follow these instructions to remove the cover.



Attaching an Antistatic Wrist Strap

Before you touch anything inside the system unit or remove any static-sensitive item from an antistatic bag, attach the antistatic wrist strap to your wrist and to an unpainted metal surface such as the power supply. (See Figure 26.)

Figure 26 Attaching Antistatic Strap



Always wear an antistatic wrist strap when handling a module.
Read the instructions on the envelope.

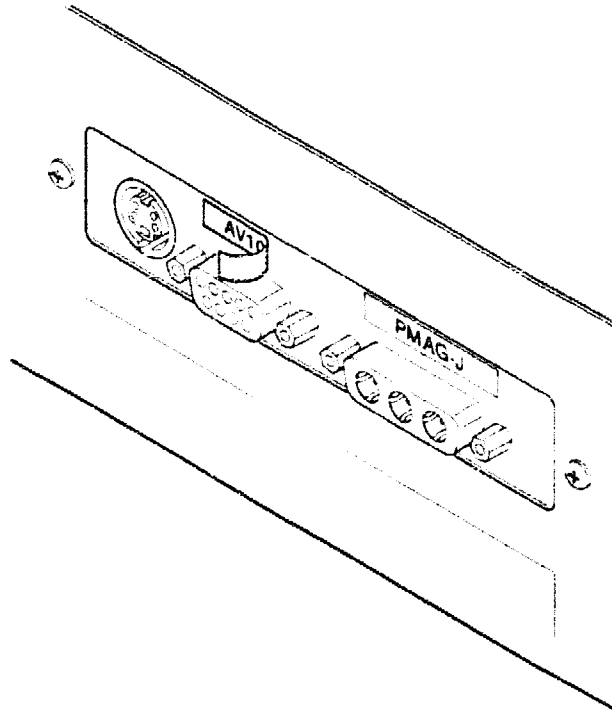
Caution

Failure to take antistatic precautions may cause damage
from static discharge.

Adding the AV10U Label

Add the AV10U label. (See Figure 27.)

Figure 27 Adding the AV10U Label



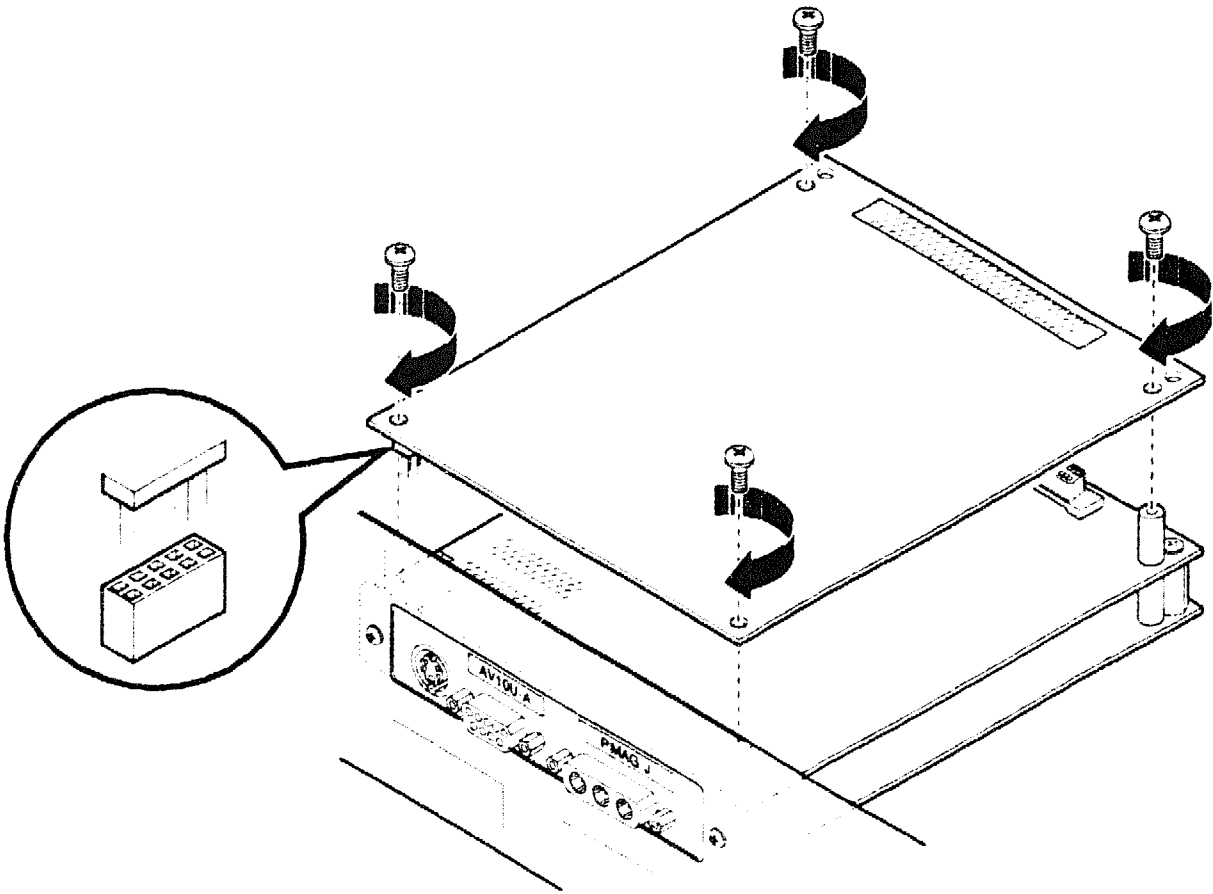
Adding the DECvideo/PIP Module to the TX Module

To add the DECvideo/PIP module to the TX module, complete the following steps:

1. Position yourself so that the back of the system unit is facing you. Hold the PIP module so that the connectors are facing down. Align the connector pins on the PIP module with the connector holes on the TX module. (The smallest connector should be facing in the direction shown in Figure 28).
2. Firmly push the connector pins on the DECvideo/PIP module into the connector sockets on the TX module.
3. Secure the DECvideo/PIP module to the TX module.

Locate the four screws in your parts kit. Insert one screw into each of the four holes in the DECvideo/PIP module. Turn each screw to the right until the DECvideo/PIP module is held firmly in place. (See Figure 28.)

Figure 28 Attaching the DECvideo/PIP module





Replacing the System Unit Cover

- Remove the antistatic wrist strap.
- Follow the instructions in your workstation operator's guide and replace the system unit cover.

Connecting Cables

The following sections describe how to:

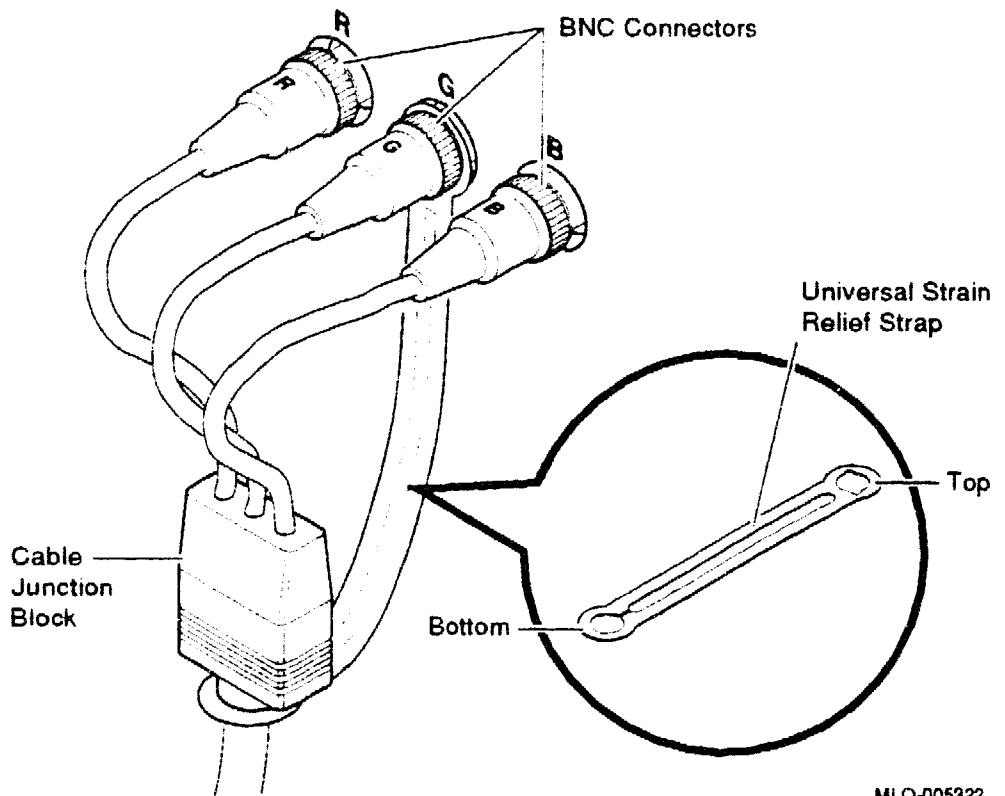
- Connect the monitor cable
- Connect the video input cable

Connecting the Monitor Cable

To connect the monitor video cable to the monitor, (see Figure 29), first attach the strain relief strap to the monitor video cable. This prevents the weight of the cable junction block from pulling the cables out of the BNC connectors. Follow these steps to attach the strap:

1. Insert the three BNC connectors and cable junction block of the video cable through the center slot of the strain relief strap, making sure the strap is under the cable junction block.
2. Pull the cable into the slotted hole at the bottom end of the strain relief strap. Bring the strap flush with the cable junction block.
3. Align the green (G) BNC connector with the two keyslots of the closed hole at the top end of the strain relief strap, and snap the BNC connector into the hole. (See Figure 29.)

Figure 29 Attaching the Strain Relief Strap to the Monitor Cable



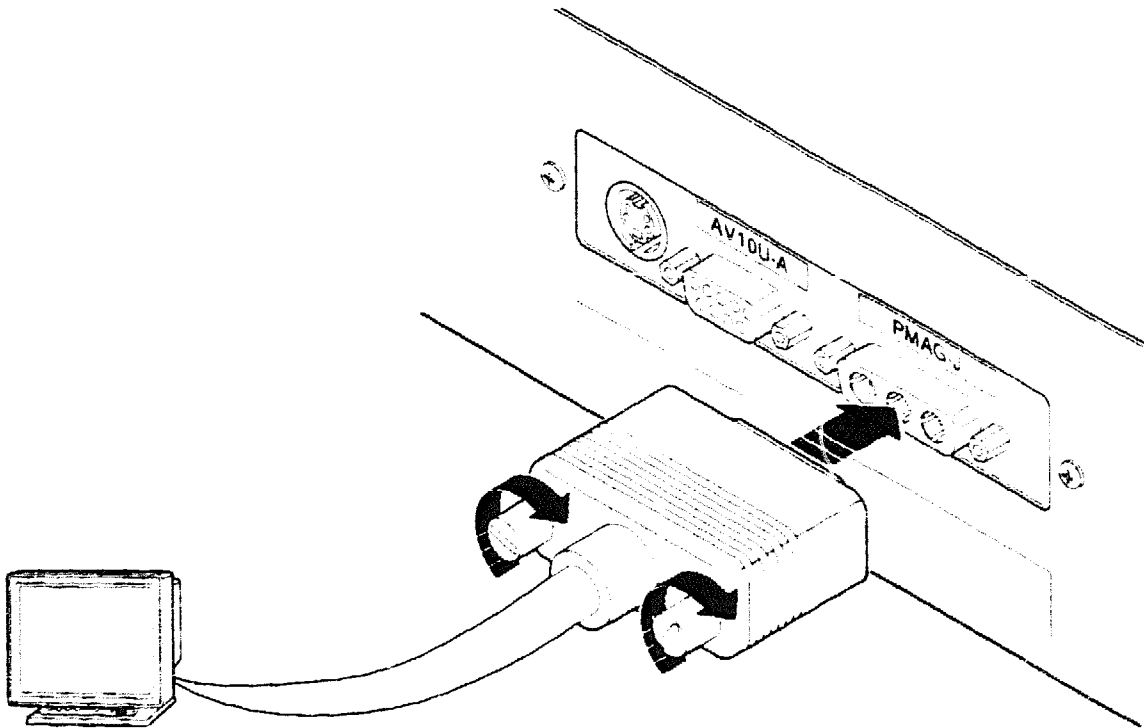
MLO-005322

Attach the monitor cable to the back of the monitor as follows:

1. Connect the red cable to the connector on the monitor marked R (for red).
2. Connect the green cable to the connector on the monitor marked G (for green).
3. Connect the blue cable to the connector on the monitor marked B (for blue).
4. Turn all three BNC connectors to the right to secure them.

Connect the 3-pin connector on the other end of the monitor cable to the DECvideo board's 3-pin socket (see Figure 30). This establishes the connection between your color monitor and the TX and the DECvideo/PIP modules.

Figure 30 Attaching Monitor Cable



Connecting the Video Input Cable

To bring the video signal from a video source to the workstation, connect the video input cable as follows:

1. Connect the 9-pin connector on the video input cable to the 9-pin socket on the DECvideo module. (See Figure 31.)

Figure 31 Attaching the Video Input Cable

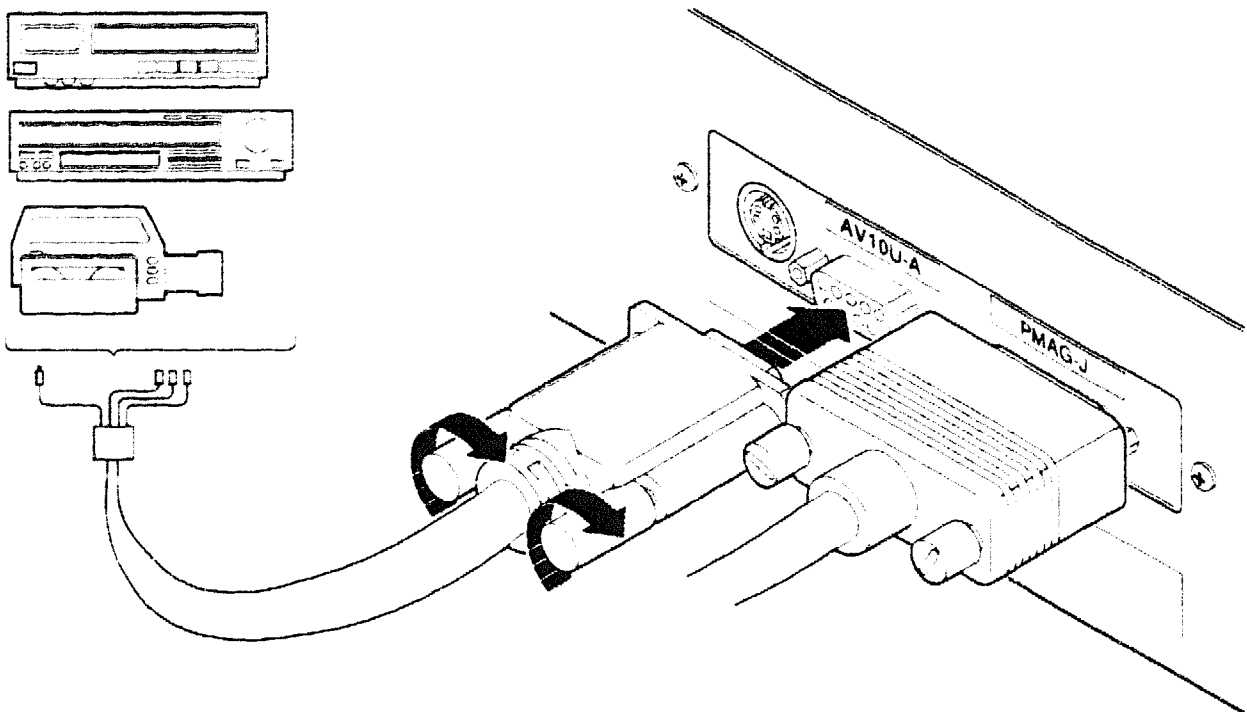
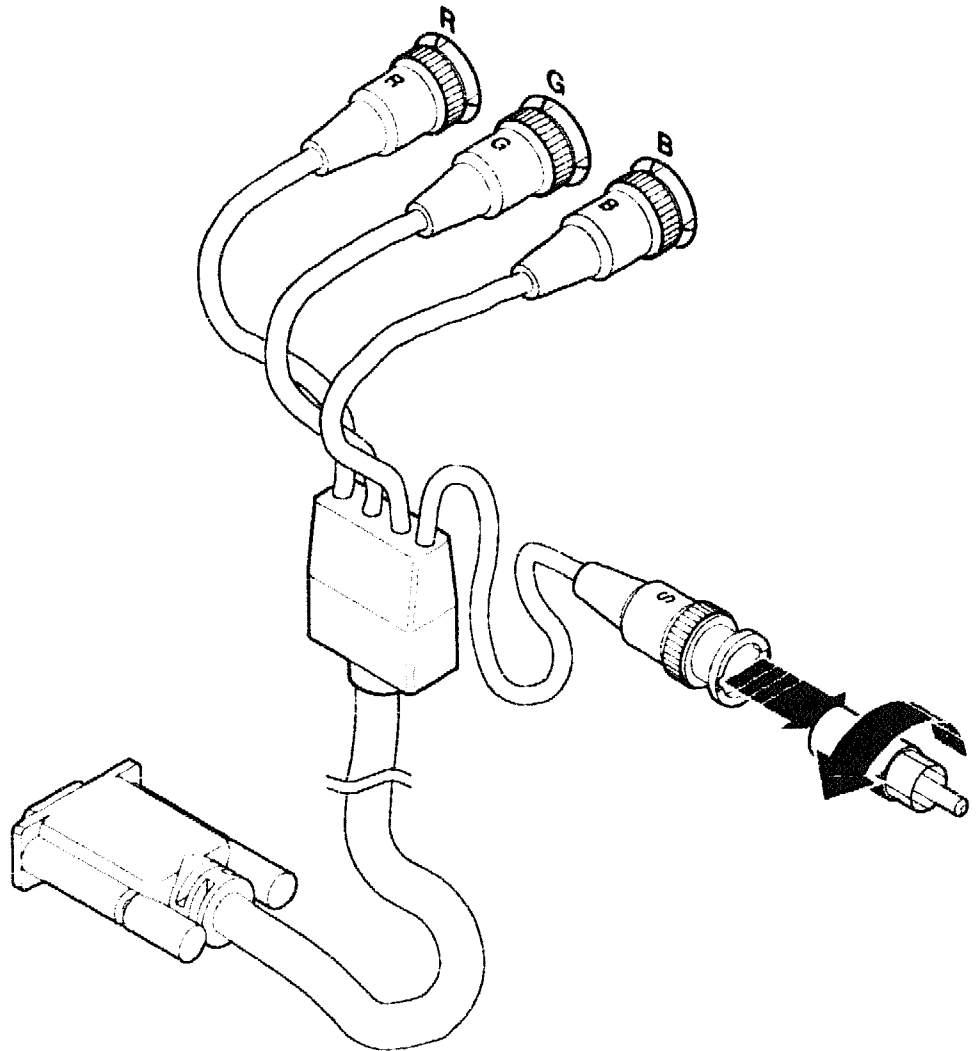


Table 4 helps you identify when to use specific video input cable connectors and the BNC-to-RCA phono plug adapter.

Table 4 Using the Video Input Cable Connectors Correctly

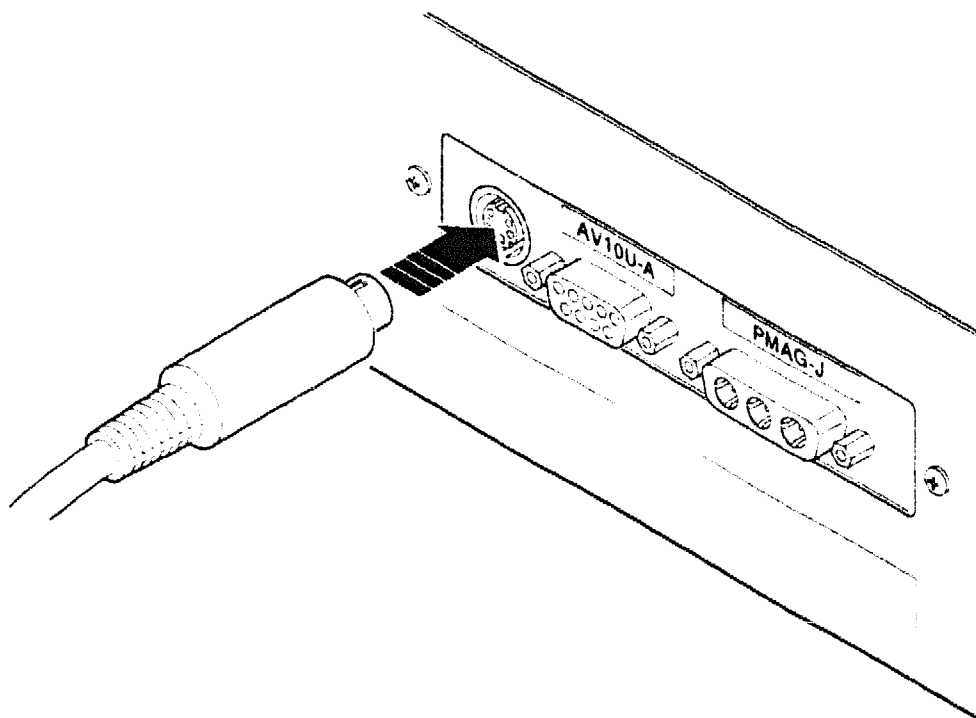
If	Then
A video source requires RGB (BNC-type) connectors	Attach the Red-Green-Blue (RGB) BNC connectors on the video input cable to the video source, such as a studio-quality camera and some VCRs. If the device requires an external sync, then connect the black BNC connector (labeled S) to the external sync. See Figure 32 for instructions to remove the phono plug adapter. Note that three BNC-terminated leads are color coded R (for red), G (for green), and B (for blue). The RGB leads are terminated with female BNC connectors.
A video source requires one BNC (composite) connector	Attach the black BNC-connector (labeled S) on the video cable to the composite connector on the video source (laser disc player or video camera).
A peripheral requires a male phono plug	Your DECvideo/PIP parts kit provides a BNC-to-RCA phono plug adapter. It came attached to the composite video BNC-connector (labeled S).
The video source outputs S-video signals (Super VHS)	Connect a shielded S-video cable (see Figure 33) with a 4-pin DIN connector to the S-video In socket. (The S-video cable is not supplied in your parts kit.)

Figure 32 RGBS Connectors



Always connect the monitor cable (see Figure 30.) Either connect the video input cable (see Figure 31), or connect the S-video cable (see Figure 33.)

Figure 33 Attaching S-Video Cable



Turning On Your System

To start your multimedia workstation, make sure your monitor is placed on your work space in a position where it is easy to for you to use, then press the (|) on the on/off switch for the monitor. Next, press the (|) on the on/off switch on the back of the system unit.



Checking a TX Configuration

To see which option modules are present in your system unit and which option slot contains the module, run a configuration test to identify the modules. The modules are identified as follows:

- By ID (or part) number
- By the number of the system unit slot that contains the module

To run the configuration test, type `cnfg` at the console prompt (`>>`) and press `Return`. A display with information about the modules in your system is displayed on the screen.

```
>>cnfg
7: KN02-BA  DEC  V5.2c  TCF0  ( 24 MB)
          (enet: 08-00-2b-0c-e0-d1)
          (scsi = 7)
6: PMAD-AA  DEC  V5.3a  TCF0  (enet: 08-00-2b-1b-c6-fb)
5: PMAZ-AA  DEC  V5.3b  TCF0  (scsi = 7)
1: PMAG-JA  DEC  V5.3a  TCF0  (TX -- d=8,24)
>>
```

The number that begins each line of the configuration display is the number of a base slot or an option slot that contains a module. Lines that begin with 0:, 1:, and 2: indicate option slots that contain TURBOchannel option modules. A slot that does not contain a module does not show up in the configuration display.

The information inside the parentheses at the end of each display line identifies the module present in that slot. In the above display, a TX color frame buffer module is present in option slot 1.

If the module that you just installed does not appear in the display, turn off the monitor and the system unit. Check that the module is firmly in place in the option slot connectors on the floor of the system unit.

Turn on the monitor and then the system unit and check the configuration display again. If the module does not appear in the display, turn off the system, then move the module to another option slot. Turn on the system unit.

Systems configured for autoboot will not display a console prompt. Console commands cannot be used with autoboot configured.

Diagnosing and Solving Problems

ROM-based diagnostics are run every time the system is turned on and every time the system is reset. These diagnostics verify that the TX module are functioning properly. If a self-test reports that the color frame buffer module is faulty, make sure the module is inserted tightly in its slot and that anything that is connected to it is connected correctly.

If the problem continues, check the error message and find the failed test. Table 5 lists the action indicated by each failed color frame buffer module self-test.

Table 5 Failed Self-Tests for the TX Color Frame Buffer Module

Failed Test	Action
curs	Replace the TX color frame buffer module.
int	
vdac	
ptrn	

Equipment Return Information

If the DECAudio diagnostics return an error message, then proceed as follows:

- If your DECmedia equipment is under a service contract or is still in warranty, then report the problem to your local Digital service representative.
- If however, you purchased your DECmedia equipment at list price, then call your Digital sales representative.

Defective parts may also be returned to your local Digital Field Service Repair Center.

Page 58 is a blank page

Connecting Peripherals

This chapter provides information about connecting multimedia peripherals to your workstation.

- Connecting a Television
- Connecting a Laser Disc Player
- Speakers and Headphones

In addition, a multimedia video teleconferencing workstation is described; its peripherals are illustrated (see Figure 34), and the cabling steps are listed (see Figure 35.)

Connecting a Television

You may display television signals with a multimedia workstation. The TX, DECvideo/PIP, and DECAudio modules are required. Some televisions have a socket labeled Video Out. This socket can be used to send television signals to a separate display. To see a TV image on both the television screen and your workstation, attach the video input cable (black BNC connector — BNC-to-RCA phono plug adapter may be needed) to the video out socket. Plug the 9-pin end of the video input cable into the DECvideo/PIP module. The image will be displayed on both screens as long as the television set is turned on. If you attach the cable from your TV antenna, you will need a tuner.

Refer to the XMedia documentation for software instructions.

Connecting a Laser Disc Player



To see video input from a laser disc, you must attach a laser disc player to your DECvideo/PIP module. Connect the composite video signal connector labeled S (see Table 4) to the composite connector on the laser disc player. (Some laser disc players require you to use the BNC-to-RCA phono plug adapter that is provided with the DECvideo/PIP parts kit.) Then, plug the other end of the video input cable into the DECvideo/PIP module.

Connecting the Laser Disc Player to the Serial Port

A serial line cable is required to support computer device control of a laser disc player. This cable (available from your laser disc dealer) has 15 pins at one end and 25 pins at the other. Connect the 15-pin end to the laser disc player, and the 25-pin end to a specific workstation serial port: either 00 or 01. Use port number 00 or 01 for the DECstation 5000 family of systems, and port number 00 for the DECstation Personal Workstation.

The port to which the laser disc player is physically connected must match the port specified in the XMedia video applications `dxgrabframes` and `dxvideoplayer`. These applications assume the default port to be `tty00`. Refer to the `dxvideoplayer` reference page for additional information.

Note

A laser disc player is not mandatory with DECmedia hardware and XMedia software. End-user applications that require the play of video in a window without computer-driven device control, can use any video source. An application writer may write device control programs for video devices with protocols that differ from XMedia-specified protocols.

XMedia Software Requirements

The XMedia video applications, `dxgrabframes` and `dxvideoplayer`, provide device control facilities for specific laser disc players. Consult the XMedia `dxvideoplayer` reference page for the information.

The function switches (1-8) on the laser disc player (specified by XMedia) should be left Off, their default settings. Confirm the Off state as follows:

1. Turn off the power to the laser disc player
2. Open the front panel cover labeled Function
3. Note that the Off position is identical to the Open position
4. Set all switches to Off
5. Close the front cover

Two communication protocol parameters (switch settings) on your laser disc player are critical to proper computer-controlled operation of the laser disc:

1. Command sequences must be terminated with CR (switch 6 = Off). Command sequences that are terminated with CRLF will not work.
2. The baud rate should be set to 4800 (switch 7 = Off). The default settings for the applications dxgrabframes and dxvideoplayer are 4800 baud. A command line setting provides for 1200 baud operation. The workstation should be set at 4800 baud.

If it is necessary to control the laser disc player with the external utility tip, then the `/etc/remote` file needs to be edited to describe the communication parameters of the laser disc player on the attached port. Refer to your XMedia reference page for tip. Normally, there is no need to use tip, and no changes are required to the `/etc/remote` file.

Speakers and Headphones



Unless you are using a television which has its own speakers, you need to attach speakers or headphones to your DECAudio distribution box in order to hear the sound associated with the video display. See Figure 13 in Chapter 2 for additional information.

Multimedia Workstation

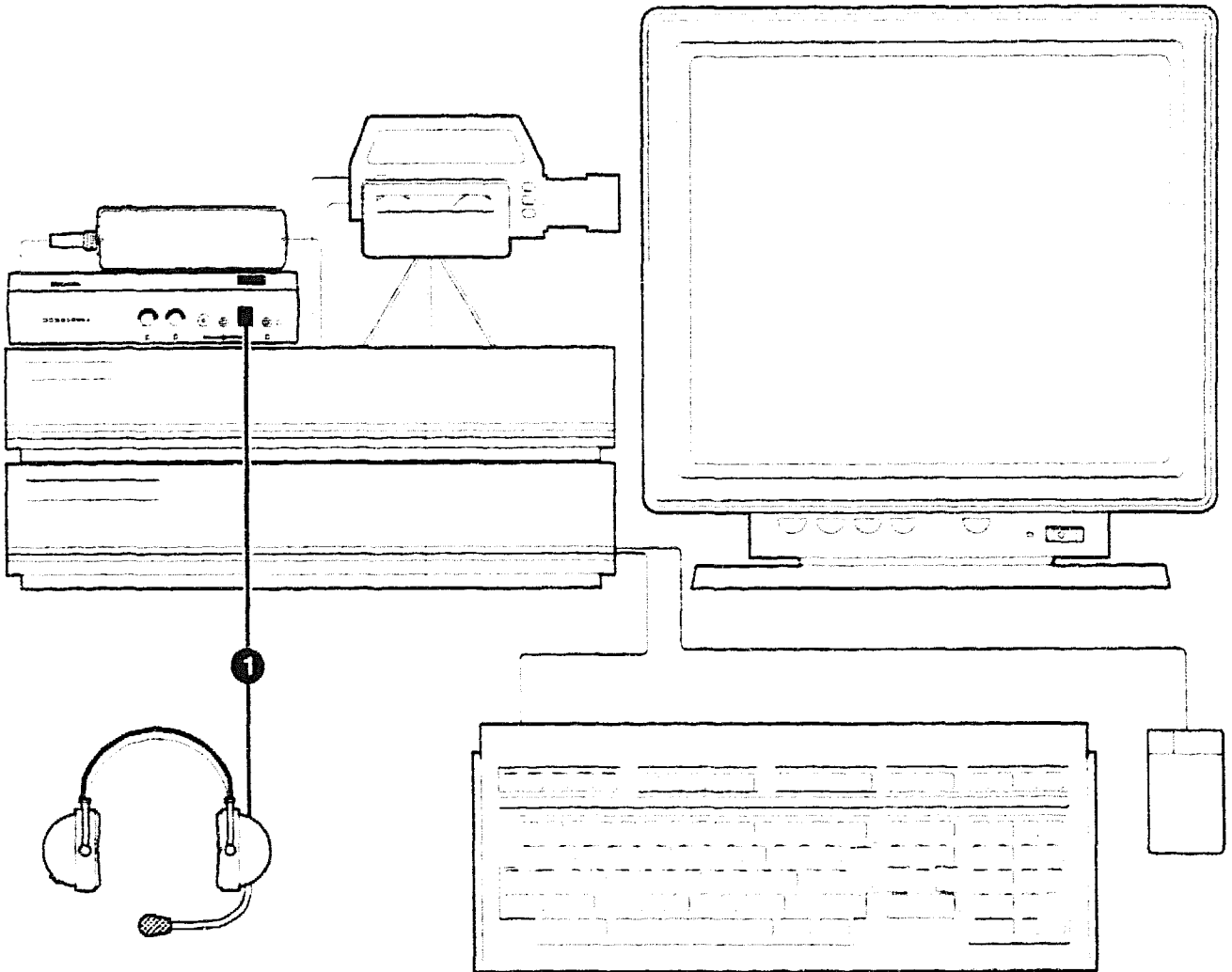
Multimedia workstations contain the hardware that lets you store information, present information, and communicate information. With the addition of software and peripheral devices, you have the potential to create multimedia training, education, presentation, communications and conferencing applications for use on the desktop.

A multimedia application may only require three or four peripherals. For example, a Digital video conferencing product called DECspin, requires a video camera, an audio output device (headphones), an audio input device (handset or microphone), a 650 megabyte to 1+ gigabyte hard disk, and a TK50 disk drive to load software.

The hardware configuration for the video conferencing workstation is shown in Figure 34.

1. Connect a headset to the telephone jack on the DECAudio distribution box.

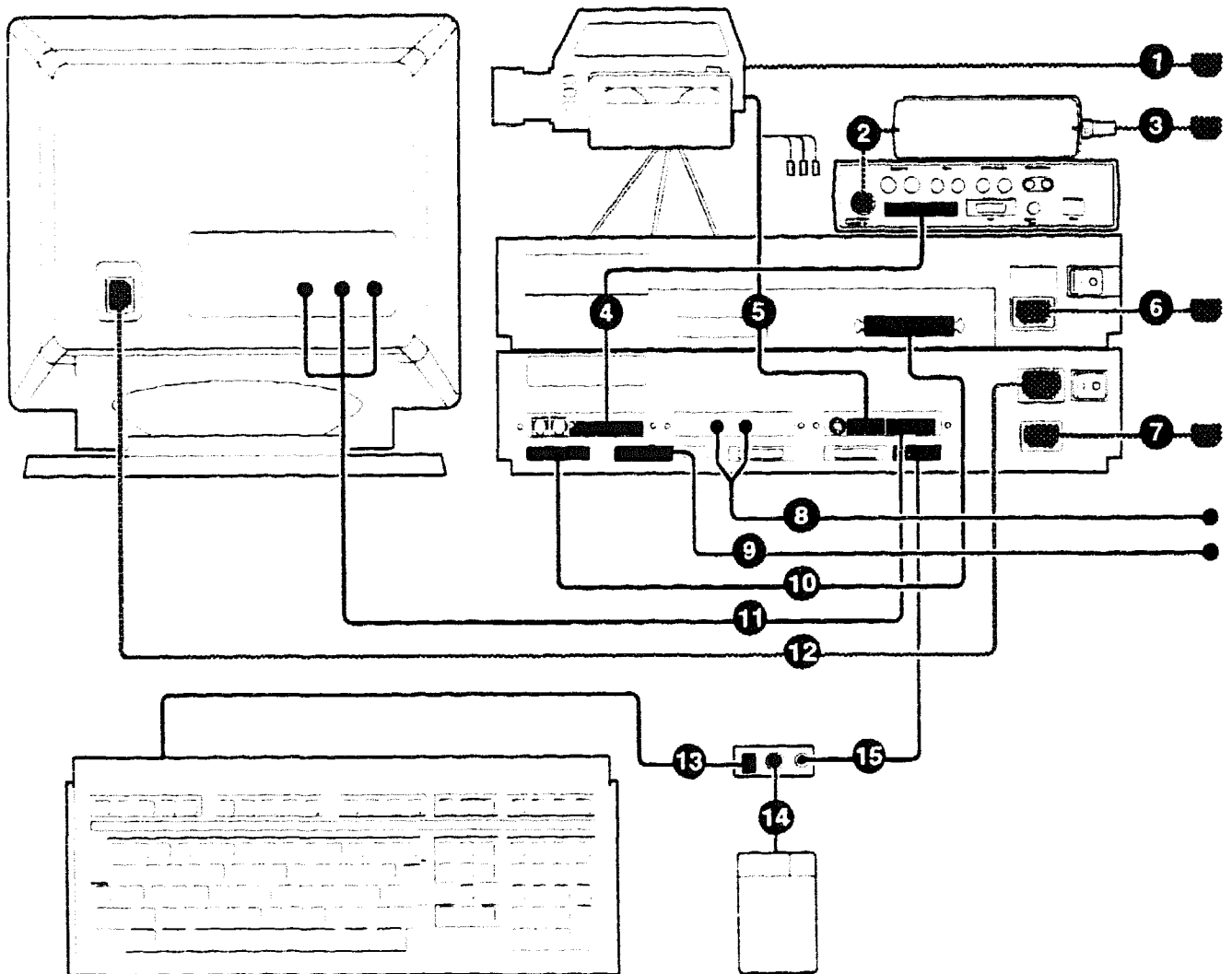
Figure 34 Example Video Conferencing Configuration



The cable connections for the DECspin video conferencing configuration are shown in Figure 35.

1. Connect camera power cord to power source.
2. Connect power cord from DECAudio distribution box to power supply.
3. Connect power cord from power supply to power source.
4. Connect DECAudio distribution cable from DECAudio TURBOchannel module connector to DECAudio distribution box.
5. Connect video input cable to DECvideo/PIP module connector and to camera video output connector. Use BNC connector labeled S, and the BNC-to-phono plug adapter (if needed).
6. Connect expansion box power cord to power source.
7. Connect system unit power cord to power source.
8. Connect DEC FDDI controller 700 module (occupies one TURBOchannel slot) to FDDI DECconcentrator 500 to network.
9. Connect Ethernet module (on system board) to network.
10. Using SCSI port on system unit, connect system unit to expansion box.
11. Connect monitor to TX module using the monitor video input cable.
12. Connect monitor power cable to auxiliary power source on system unit.
13. Connect keyboard cable to connector block.
14. Connect mouse to connector block.
15. Connect keyboard extension cable to the keyboard-mouse connector on the back of the system unit.

Figure 35 Cable Connections for a DECspin Video Conferencing Workstation



Page 66 is a blank page

A

For the Digital Service Representative

This appendix contains information specifically for the Digital service representative.

A Digital service representative uses the same DECAudio and DECvideo ROM-based diagnostics that the customer uses to verify the functionality of the audio and video modules. See Chapter 2 and Chapter 3 for diagnostics.

Use Table 6 to order field replaceable units (FRU) for the customer:

Table 6 DECmedia Hardware Field Replaceable Units

Field Replaceable Unit	Order number
DECAudio TC module	54-21123-01
DECAudio cable	17-03089-01
DECAudio distribution box	70-28758-01
DECAudio power supply	30-35431-01
AC cable for power supply	17-00606-10
DECvideo TX color frame buffer (66 Hz)	30-35790-01
DECvideo TX color frame buffer (72 Hz)	30-35790-02
DECvideo input cable	17-03304-01
DECvideo/PIP module	30-35788-01
VRT19 color monitor cable	17-02906-01

A replacement antistatic wrist strap may be ordered using part number 12-36175-01. The DECAudio distribution box stand is not a field replaceable unit.

Page 68 is a blank page

Hardware Specifications

This appendix provides the hardware specification for DECAudio, TX and DECvideo/PIP products as follows:

- DECAudio system specifications (Table 7)
- DECAudio Non-operating Conditions (Table 8)
- DECAudio Operating Conditions (Table 9)
- DECAudio Power Requirements (Table 10)
- DECAudio Distribution Box Connectors Type and Function (Table 11)
- DECAudio Interface Connector and Cable (Table 12)
- DECvideo Non-operating Conditions (Table 13)
- DECvideo Operating Conditions (Table 14)

Table 7 DECAudio Specifications

Monaural frequency response	+/-0.5 dB relative to the 1020 Hz point from 300 Hz to 3000 Hz
Stereo frequency response	20 Hz to 20 KHz
Total Harmonic Distortion (THD)	All outputs, -38 DB at 1020 Hz with amplitude of full scale sine wave
Audio Inputs	
—Mono Line In	10k ohms
—Mic Input Impedance	20k ohms
—Handset Input Circuit	3.3k in series with equivalent 1.8 V voltage source

(continued on next page)

Table 7 (Cont.) DECAudio Specifications

Amplifier Gain	Adjustable over a +/-18 dB range by means of software control
Microphone Sensitivity ¹	-44 and -71 dBV where dBV is the open-circuit output voltage relative to 1 V at an input pressure of 1 μ bar
Audio Outputs	
—Mono Line Out	510 ohms +/-10%
—Mono Speakers 1 and 2	Output impedance: <2 ohms (load resistance should not be less than 8 ohms, internal speaker is 8 ohms typical)
—Stereo line out (left and right)	Output impedance: 100 ohms, output level: 0.9 V rms, channel separation: 60 dB minimum at 1 kHz
—Stereo headphone output	Output impedance: <2 ohms (load resistance should not be less than 8 ohms for each channel), output power: 200 mW, channel separation: 60 dB minimum at 1 kHz
Signal Levels	
—Mono Line In	1.93 V +/-10% through a 600 ohm source impedance
—Mic Input	Sine wave signal level (+/- 10%) required to produce a full-scale μ -law file is: ga+gx = 0 dB 50.3 mV rms ga+gx = 18 dB 6.3 mV rms ga+gx = 36 dB 0.78 mV rms
—Handset Input	Multiply mic input values by 21 +/-4%
—Mono Line Out Signal produced with a full scale μ -law sine wave file	0.865 V +/-10%
—Mono Speakers 1 and 2 Signal produced with a full scale μ -law sine wave file	0.98 V +/-10%

¹See the section entitled Using Microphones, Chapter 2, for additional information.

Table 8 DEAudio Non-operating Conditions

Temperature range	-40°C (-40°F) to 66°C (151°F)
Relative humidity	95% at 66°C may condense
Maximum wet bulb temperature	28°C (82°F)
Maximum dew point	2°C (36°F)
Altitude	4900 m (16,000 ft)

Table 9 DEAudio Operating Conditions

Temperature range	10°C (50°F) to 40°C (104°F)
Temperature change rate	11°C (20°F) degrees per hour maximum
Relative humidity	10% to 90% noncondensing
Maximum wet bulb temperature	28°C (82°F)
Altitude	2400 m (8000 ft) at 36°C (96°F)

Table 10 DEAudio Power Requirements

DEAudio module	+5 V at 1.2 amps max from TURBOchannel
DEAudio Distribution Box	+5 V (from external modular power supply) +12 V (from external modular power supply) -12 V (from external modular power supply)

Table 11 DECAudio Distribution Box Connectors Type and Function

15 position D female	DSP port
5 position DIN female	DC power input
Miniature phone jack	Mic input (mouth of handset)
RCA phono jacks (2)	Line level codec input/output
RCA phono jacks (2)	Line level stereo outputs (left and right)
Miniature phone jack	Stereo headphone out
Miniature phone jack	Mono Speaker 1
Miniature phone jack	Mono Speaker 2
4 position MJ	Handset
8 position MJ	ISDN "S"

Table 12 DECAudio Interface Connector and Cable

60 position D	DECAudio interface; 2 meters long. 30 twisted pairs of 28 AWG wire with opposing pins comprising a pair
---------------	---

Table 13 TX, DECvideo/PIP Non-operating Conditions

Temperature range	-40°C (-40°F) to 66°C (151°F)
Relative humidity	95% maximum
Altitude	4900 m (16,000 ft)

Table 14 DECvideo/PIP Operating Conditions

Temperature range	10°C (50°F) to 40°C (104°F) Derated 1.8° C/Km 1° F/1,000 ft.
Relative humidity	10% to 90% noncondensing
Maximum wet bulb temperature	28°C (82°F)
Minimum dew point	2°C (36°F)
Altitude	2,400 m (8,000 ft) at 36°C (96°F)

Glossary

This glossary contains concepts, terms, acronyms, and services associated with multimedia.

brightness

The intensity of a color (relative to black) on a monitor. Signals with a high luminance value produce bright colors on the display. Overall system brightness can be modified on the TX color frame buffer through software, as can contrast, hue, and saturation.

chrominance

The color component of a composite signal or S-video signal. Chrominance also refers to the color component of any image, as opposed to its grayscale value or luminance. In terms of the NTSC color standard, chrominance contains the combined I and Q components of the signal.

composite video signal

Composite video signal types combine the YUV and sync signal on one wire. The video output on a VCR is a composite video signal, that can be received as video input by a television monitor.

composite color signal

A color display signal that transmits all necessary information (color, brightness, sync, and other information) together. The device that receives the composite signal must decode the various kinds of information in order to display an image. Mixing color and brightness information together, then separating the information in this way, compromises the quality of the final image because some information is lost. Compare with *S-video signal* and *RGB signal*, both of which produce a higher-quality image than composite signals.

contrast

The ratio between the maximum and minimum luminance (brightness) values of a display.

drawable

A collective term for windows and pixmap, which can both be used as sources and destinations in graphics operations.

frame buffer

Memory used to store an array of graphic image data. Each element of the array corresponds to one or more pixels in a video display. See also *pixel*.

hue

Hue represents the frequency of color and its position in the visible spectrum.

ISDN

Integrated system digital network

luminance

The brightness or grayscale component of an S-video or composite signal. As the chrominance value gives an S-video signal its hue, luminance defines its brightness. In terms of the NTSC color standard, luminance contains the Y signal, while chrominance contains the combined I and Q signals. Also used interchangeably with the term *brightness*.

MIDI

Musical instrument digital interface

multimedia

A set of technologies that allow for the capture, manipulation, presentation, and integration of information involving data types such as text, graphics, and images, as well as animation, full-motion video, and high-quality audio.

NTSC

A color-encoding and decoding system for the transmission of video signals, 640 lines wide by 480 lines high at 30 Hz, adopted by the National Television System Committee in 1953. The NTSC standard was the first monochrome-compatible, simultaneous color system used for public broadcasting. It was adopted by the Federal Communications Commission for use in the United States. The NTSC color-encoding standard is also used in Canada, Japan, and Mexico. Compare with *PAL* and *SECAM*.

Phase Alternation Line (PAL)

A color-encoding and decoding system for the transmission of video signals, 625 lines per frame at 50 Hz, used in most European countries. Compare with *NTSC* and *SECAM*.

Picture in a picture (PIP)

A live video display in a window that occupies a portion of the screen.

pixel

A picture element that is the basic unit of a graphic display. A location on the monitor screen that can be selectively turned on or off. The more pixels to a screen unit, the higher the picture resolution.

PSTN

Public switched telephone network

raster

The electron beam that scans the image onto a picture tube. Raster images are generated with an intensity-controlled, line-by-line sweep of the electron beam across the screen. Television sets use raster displays.

RGB signal

An abbreviation red, green, blue used to indicate the most effective method of transmitting a graphics or video signal so that the information remains pure. RGB is a three-wire system: one wire is used to transmit separately each of three primary colors (red, green, blue). The resulting image is higher in quality than the image from S-video or composite signals. The sync signal for RGB can either be transmitted on a separate wire, or encoded on

one of the R, G, or B wires. On Digital Equipment Corporation video displays, the sync signal is encoded on the green wire.

read-only memory (ROM)

Memory that cannot be modified. The system can use (read) the data in ROM but cannot change it.

saturation

The richness of a color, as determined by the amount of white in the color.

SECAM

See *Systeme Electronique Couleur Avec Memoire*.

Systeme Electronique Couleur Avec Memoire (SECAM)

A color-encoding and decoding system for the transmission of video signals, 625 lines per frame at 50 Hz. The SECAM system is used in France and the USSR. Compare with *NTSC* and *PAL*.

S-video signal

A super-video signal that carries the luminance (brightness) information and chrominance (color) information separately. The S-video signal is the same as the composite video signal, except that the Y signal (intensity) is on a separate wire from the U-V signal. Some high-end VCRs have an S-video output for connection to high-end television monitors. Contrast with *composite* and *RGB*.

Index

A

- Antistatic strap
 - using, 13, 36, 46
- Audio server
 - device independence, 6

C

- Cable
 - attaching monitor cable, 49
 - connect to serial port, 60
 - video input, 52
- cnfg* command, 29, 56
- Color frame buffer
 - removing, 38
- Configuration
 - video conferencing, 63, 65
- Conventions
 - used in this guide, x

D

- DECAudio
 - attaching antistatic strap, 13
 - checking configuration display, 29
 - connecting distribution cable, 19
 - customer return information, 32
 - description of, 9
 - distribution box connectors, 72
 - figure of module, 15, 16, 18
 - hardware specifications, 69
 - installing, 15
 - installing module, 12

DECAudio (Cont.)

- interface connector and cable, 72
 - non-operating conditions, 71
 - operating conditions, 71
 - power requirements, 71
 - pst-q* power-up test, 30
 - pst-t* power-up test, 31
 - removing label over telephone connectors, 19
 - removing the options slot cover, 14
 - secure module to TURBOchannel, 17
 - specifications, 69
 - telephone set and line test, 30
 - unpacking, 10
- DECmedia
 - list of products, 1
 - DECvideo/PIP
 - adding AV10U label, 47
 - adding PIP to TX module, 47
 - attaching strain relief strap, 50
 - connecting monitor cable, 50
 - connecting peripherals, 49
 - connecting S-video cable, 55
 - connecting video input cable, 49, 51, 52
 - customer return information, 57
 - hardware specifications, 69
 - installing, 44
 - installing modules, 35, 45
 - non-operating conditions, 72
 - operating conditions, 72
 - RGBS connectors, 54
 - unpacking, 44
 - unpacking hardware, 44
 - Diagnosing problems
 - pst-q* power-up test, 30

Diagnosing problems (Cont.)

- pst-t* power-up test, 31
- telephone set and line test, 30

Distribution box

- connecting cables, 24
- connecting peripheral equipment to, 22
- speaker, 22

G

Graphics module

- removing, 38

H

Hardware for

- video conferencing, 62, 65

L

Laser disc player

- connecting to a workstation, 60
- protocol parameters need changing, 60

M

Microphone

- specifications, 28

Monitor

- attaching cable, 49

Multimedia

- overview of, 1
- software, 5

P

Problems

- DECAudio diagnostics, 30
- DECvideo diagnostics, 57

R

Removing

- existing module, 38

RGBS connectors

- connecting, 54

RISC workstations

- as multimedia systems, 3

S

Serial port

- connecting a laser disc player, 60

S-Video

- connecting cable, 55

System unit

- removing cover, 12, 35, 45
- replacing cover, 18, 43, 49
- shutting down software, 12, 35
- turning on, 28, 43

T

Television

- cabling TV to workstation, 59

TURBOchannel

- audio module, 9
- module characteristics, 7
- overview of, 7

Turning off the system, 12, 35, 45

Turning on the system, 28, 43, 55

TX

- adding PIP module, 47
- antistatic strap, 36, 46
- checking configuration display, 56
- connecting monitor cable, 49
- inserting module in option slot, 40
- installing TX color frame buffer, 40
- non-operating conditions, 72
- removing old color frame buffer, 38
- removing options slot cover, 37
- replace system unit cover, 43
- securing the module, 42
- slip old color buffer out of option slot opening, 39
- unpacking, 34

U

Unpacking

- DECaudio hardware, 10, 11
- DECvideo/PIP hardware, 44
- TX hardware, 34

V

- Video input cable
 - connecting, 52

X

- XMedia software
 - overview, 5