

# DECmpp 12000/Sx Model 100

---

## Hardware Installation Guide

Part Number: EK-DECAC-IG. C01

**September 1992**

This manual describes the site preparation and installation procedures for the DECMpp 12000/Sx and DECMpp 12000-LC/Sx Series hardware.

**Revision/Update Information:** This document has been revised for DECMpp Version 1.1.

**Operating System and Version:** ULTRIX Version 4.2A.  
Future releases may require higher versions.

**Software Version:** DECMpp 12000/Sx Version 1.1.

**Digital Equipment Corporation  
Maynard, Massachusetts**

---

**First Printing, January 1992**  
**Revised, September 1992**

The information in this document is subject to change without notice and should not be construed as a commitment by Digital Equipment Corporation. Digital Equipment Corporation assumes no responsibility for any errors that may appear in this document.

The software described in this document is furnished under a license and may be used or copied only in accordance with the terms of such license.

**NOTICE—Class A Computing Device:**

This equipment generates, uses, and may emit radio frequency energy. The equipment has been type tested and found to comply with the limits for a Class A computing device pursuant to Subpart J or Part 15 of FCC rules, which are designed to provide reasonable protection against such radio frequency interference when operated in a commercial environment. Operation of this equipment in a residential area may cause interference; in which case, measures taken to correct the interference are at the user's expense.

Restricted Rights: Use, duplication, or disclosure by the U.S. Government is subject to restrictions as set forth in subparagraph (c)(1)(ii) of the Rights in Technical Data and Computer Software clause at DFARS 252.227-7013.

© Digital Equipment Corporation 1992.

All Rights Reserved.

The postpaid Reader's Comments forms at the end of this document request your critical evaluation to assist in preparing future documentation.

The following are trademarks of Digital Equipment Corporation: DECnet, DECstation, DECsupport, DECsystem, DECwindows, Rdb/VMS, ThinWire, TURBOchannel, ULTRIX, VAX, VAX DOCUMENT, VMS, and the DIGITAL logo.

The following are registered trademarks of the MasPar Computer Corporation: MasPar and the MasPar logo. The following are trademarks of the MasPar Computer Corporation: MasPar Data Display Library (MPDDL), MasPar FORTRAN (MPF), MasPar Input/Output Channel, MasPar Parallel Application Language (MPL), MasPar Parallel Disk Array (MPDA), and MasPar Programming Environment (MPPE). UNIX is a registered trademark of UNIX System Laboratories, Inc.

This document was prepared using VAX DOCUMENT, Version 2.0.

---

# Contents

<b>Preface</b> .....	vii
<b>1 Introduction</b>	
<b>2 Site Preparation</b>	
2.1    DECmpp 12000/Sx Site Preparation .....	2-2
2.1.1    Physical Characteristics .....	2-2
2.1.1.1    Size and Service Clearance .....	2-2
2.1.1.2    Weight .....	2-2
2.1.2    Electrical Requirements .....	2-3
2.1.2.1    Cables .....	2-5
2.1.3    Environmental Considerations .....	2-6
2.1.3.1    Cooling .....	2-6
2.1.3.2    Temperature and Humidity .....	2-6
2.1.3.3    Static Electricity .....	2-7
2.1.4    Additional Equipment .....	2-7
2.1.4.1    Modem .....	2-7
2.1.4.2    Ethernet .....	2-7
2.2    DECmpp 12000-LC/Sx Site Preparation .....	2-8
2.2.1    Physical Characteristics .....	2-8
2.2.1.1    Size and Service Clearance .....	2-8
2.2.1.2    Weight .....	2-8
2.2.2    Electrical Requirements .....	2-9
2.2.2.1    Cables .....	2-10
2.2.3    Environmental Considerations .....	2-10
2.2.3.1    Cooling .....	2-10
2.2.3.2    Temperature and Humidity .....	2-11
2.2.3.3    Static Electricity .....	2-11
2.2.4    Additional Equipment .....	2-11
2.2.4.1    Modem .....	2-11
2.2.4.2    Ethernet .....	2-11
2.3    Parallel Disk Array Site Preparation .....	2-12
2.3.1    Physical Characteristics .....	2-12
2.3.1.1    Size and Service Clearance .....	2-12
2.3.1.2    Weight .....	2-12
2.3.2    Power and Cooling Requirements .....	2-13
2.3.3    Power and Environmental Specifications .....	2-13

### 3 System Hardware Installation

3.1	Installation Overview . . . . .	3-1
3.2	Unpacking and Inspection . . . . .	3-2
3.2.1	Unpacking and Positioning the DECmpp 12000/Sx Server . . . . .	3-2
3.2.2	Unpacking and Positioning the DECmpp 12000-LC/Sx Server . . . . .	3-2
3.2.3	Unpacking and Positioning the DECmpp 12000/Sx DPU . . . . .	3-3
3.2.3.1	Assembling the Enclosure Skirts . . . . .	3-5
3.2.4	Unpacking and Positioning the DECmpp 12000-LC/Sx DPU . . . . .	3-7
3.3	Front-End Server Installation . . . . .	3-12
3.3.1	Installing the DECsystem 5900 . . . . .	3-12
3.3.2	Installing the DECstation 5000 . . . . .	3-13
3.4	Data Parallel Unit Installation . . . . .	3-13
3.4.1	Handling PCBs Correctly . . . . .	3-14
3.4.2	Data Parallel Unit PCBs . . . . .	3-15
3.4.2.1	Array Control Unit Jumper Settings . . . . .	3-15
3.4.3	Data Parallel Unit Card Cage Access . . . . .	3-15
3.4.3.1	Data Parallel Unit Card Cage Slots . . . . .	3-16
3.4.3.2	Installing the PCBs . . . . .	3-19
3.4.4	Data Parallel Unit Backplane Jumpers . . . . .	3-19
3.4.5	Connecting the Data Parallel Unit and DECstation Cables . . . . .	3-22
3.4.5.1	Connecting the Internal DPU Cables (DECmpp 12000-LC only) . . . . .	3-23
3.4.5.2	Connecting the External DPU Cables . . . . .	3-23
3.4.6	Preparing the System Modem . . . . .	3-24
3.4.7	Connecting the DPU Power Cable . . . . .	3-25
3.5	DPU Controls and Indicators . . . . .	3-26
3.5.1	Front Controls and Indicator . . . . .	3-26
3.5.2	Rear Controls and Indicators . . . . .	3-27
3.6	Powering Up the DPU for the First Time . . . . .	3-28
3.6.1	Powerup Sequence Summary . . . . .	3-34
3.6.2	Powerdown Sequence Summary . . . . .	3-34

#### A Installation Checklist

A.1	Installation Steps . . . . .	A-1
-----	------------------------------	-----

#### B Power Cable Wiring and Replacement

B.1	Power Cable Wires . . . . .	B-1
B.1.1	Wire Ends . . . . .	B-1
B.1.2	Replacing the Power Cable . . . . .	B-1

#### C DECmpp Variations and Options

#### Index

## Figures

1-1	Typical DECmpp 12000/Sx Installation with DECsystem 5900 Server .....	1-2
1-2	Typical DECmpp 12000/Sx Installation with DECstation 5000/240 Server .....	1-2
1-3	Typical DECmpp 12000-LC Installation .....	1-3
2-1	DECmpp 12000 Enclosure Dimensions .....	2-3
2-2	DECmpp 12000-LC/Sx DPU Enclosure Dimensions .....	2-9
3-1	Removing Enclosure Shipping Bracket .....	3-3
3-2	DECmpp 12000/Sx DPU Enclosure Levelers .....	3-4
3-3	Front and Side Skirts .....	3-5
3-4	Rear Skirt .....	3-6
3-5	Unopened Shipping Container .....	3-8
3-6	Removing the Front Board .....	3-9
3-7	Ramp Ready to Use .....	3-10
3-8	Setting the Levelers .....	3-11
3-9	DECsystem 5900 Power Controller .....	3-12
3-10	DECsystem 5900 System Power Switch .....	3-12
3-11	PCB Ejector Levers .....	3-14
3-12	Array Control Unit Jumpers .....	3-16
3-13	DECmpp 12000/Sx System and Card Cage (Rear View) .....	3-17
3-14	Data Parallel Unit Card Cage Slots .....	3-18
3-15	Data Parallel Unit Backplane Jumper Locations .....	3-20
3-16	ACU/MPVMEbus Backplane Jumpers .....	3-21
3-17	DPU-Server Cables .....	3-22
3-18	DECsystem 5900 CPU Rear Panel Connectors .....	3-24
3-19	DECstation 5000 Rear Panel Connectors .....	3-24
3-20	Data Parallel Unit Front Controls .....	3-26
3-21	Data Parallel Unit Rear Controls and Indicators .....	3-27
3-22	DPU Backplane Voltage Test Points .....	3-29
3-23	DECmpp 12000 Power Supply Voltage Adjustments .....	3-30
3-24	DECmpp 12000-LC/Sx HC Power Supply and Voltage Adjustments .....	3-31
3-25	DECmpp 12000-LC/Sx Powertec Power Supply and Voltage Adjustments .....	3-31

## Tables

1	Related Documents .....	viii
2-1	DECmpp 12000/Sx Power Specifications .....	2-4
2-2	Alternate Cables .....	2-5
2-3	DECmpp 12000/Sx Temperature/Humidity Specifications .....	2-6
2-4	DECmpp 12000-LC/Sx Power Specifications .....	2-10
2-5	DECmpp 12000-LC/Sx Temperature/Humidity Specifications .....	2-11
2-6	PDA Specifications .....	2-13
3-1	ACU Jumper Settings .....	3-15
C-1	DECmpp 12000/Sx Systems .....	C-1

C-2	DECmpp 12000-LC/Sx Series Systems . . . . .	C-3
C-3	DECmpp 12000 Processor Element Array Options . . . . .	C-3
C-4	DECmpp MPVMEbus Options . . . . .	C-3

---

# Preface

This manual provides site preparation and installation procedures for DECmpp 12000/Sx and DECmpp 12000–LC/Sx Series systems.

If you need assistance during the installation, call:

## CUSTOMER SUPPORT CENTER

**1-800-354-9000** (U.S. and Canada)

Ask for DECmpp Support

## Intended Audience

This guide is for use by Digital Services personnel and by self-maintenance customers. Installation begins when site preparation is completed and the DECmpp 12000/Sx system has been delivered on a skid to the computer room.

If necessary, refer to the *DECstation 5000 Site Preparation Guide* or the *DECsystem 5900 Site Preparation Guide*, depending on your configuration.

## Required Tools

The tools required to unpack and install the DECmpp 12000/Sx system are:

- Scissors or knife for opening packages
- Screwdrivers: variety of Phillips and conventional flat blades
- Wrenches: 3/4-inch to remove hold-down brackets and 9/16-inch to bring feet down
- Allen wrench, 1/4-inch, to open cabinet doors
- Pliers: a thin, long-nose to add or remove backplane jumpers

## Document Structure

The *DECmpp 12000/Sx Hardware Installation Guide* includes three chapters and three appendixes.

- Chapter 1 provides introductory information for the DECmpp 12000/Sx Series product.
- Chapter 2 provides site preparation information.
- Chapter 3 describes how to install the cabinet and system components. This chapter also provides the procedures for turning the system on and off and booting.
- Appendix A is an installation checklist.

- Appendix B provides instructions on power cable wiring and cable replacement for the DECmpp 12000/Sx.
- Appendix C provides a list of part numbers for all DECmpp 12000/Sx series system configurations and options associated with the DPU.

For DECmpp 12000/Sx systems, you also need the *DECsystem 5900 Installation Guide* or the *DECstation 5000 Hardware Installation Guide*, depending upon the server ordered. This document is included with the server.

For DECmpp 12000-LC/Sx systems, you also need the *DECstation 5000 Hardware Installation Guide*. This document is included with the DECstation 5000 server.

## Related Documents

Table 1 lists documents that provide additional information about the DECmpp 12000/Sx system:

**Table 1 Related Documents**

Document Title	Order Number
<i>DECmpp 12000/Sx System Overview Manual</i>	AA-PMAPB-TE
<i>DECmpp 12000/Sx System Administration Guide</i>	AA-PKU3C-TE
<i>DECmpp 12000/Sx Architecture Specification</i>	AA-PMASB-TE
<i>DECmpp 12000/Sx Hardware Service Manual</i>	EK-DECAC-SM
<i>DECmpp 12000/Sx Parallel Disk Array Reference Manual</i>	EK-DECAB-RM
<i>DECmpp 12000/Sx Parallel VME Reference Manual</i>	EK-DECAB-PM
<i>DECstation 5000/240 User Documentation Kit</i>	EK-PM380-DK
<i>DECstation 5000/240 Maintenance Guide</i>	EK-PM38C-MG
<i>DECstation 5000/240 Pocket Service Guide</i>	EK-PM38D-PG
<i>DECsystem 5900 Site Preparation Guide</i>	EK-D590A-SP
<i>DECsystem 5900 Installation Guide</i>	EK-D590A-IN
<i>DECsystem 5900 Owner's Guide</i>	EK-D590A-OG
<i>DECsystem 5900 Pocket Service Guide</i>	EK-D590A-PS
<i>DECsystem 5900 Enclosure Maintenance Manual</i>	EK-D590A-EN
<i>DWTVX-Ax VME I/O Subsystem Pocket Service Guide</i>	EK-DWTVX-PS
<i>T6000 Module Installation/Owner's Card</i>	EK-T6000-IN

## Conventions

The following conventions are used throughout the DECmpp 12000/Sx documentation set.

Convention	Meaning
<code>Return</code>	In examples, a key name shown within a box indicates that you press a key on the keyboard. In text, a key name is not enclosed in a box but is printed with an initial capital letter, like Return.
<code>Ctrl/x</code>	A key combination, shown with a slash separating the two key names, indicates that you hold down the first key while you press the second key.
<code>MB1, MB2, MB3</code>	The buttons on a mouse. MB1 is the left button, MB2 is the center button, and MB3 is the right button of a mouse whose button arrangement is right-handed. It is possible to redefine the mouse buttons.
<code>%</code>	A percent sign (%) represents the default user prompt for your system.
<code>#</code>	A number sign (#) represents the default superuser (root) prompt for your system.
<code>...</code>	In examples, a horizontal series of dots, or ellipsis, indicates that additional parameters, values, or other information can be entered.
<code>:</code>	In examples, a vertical series of dots, or vertical ellipsis, indicates that a portion of the example is intentionally omitted.
<code>[]</code>	In syntax descriptions and functional descriptions, brackets indicate optional items.
<code>dpumanager(6)</code>	Cross-references to the <i>ULTRIX Reference Pages</i> , which include the appropriate section number in parentheses.
<i>italicized text</i>	In examples, italicized text denotes parameters, values, or other information that will change from either session to session or user to user. In text, italicized words or phrases are used to add emphasis to important words, concepts, or titles of manuals.
ULTRIX keywords	This typeface is used to indicate system output or the exact name of a command, option, partition, pathname, directory, or file.
Code examples	This typeface is used to display program coding examples.
UPPERCASE and lowercase strings	The ULTRIX system differentiates between lowercase and uppercase characters. Literal strings that appear in text, examples, syntax descriptions, and function descriptions must be entered exactly as shown.

Both the DECmpp 12000/Sx and DECmpp 12000-LC/Sx Series hardware systems are described in this manual. However, because the two systems are very similar, references to the DECmpp 12000 system also apply to the DECmpp 12000-LC system, unless specific differences between the two systems are noted.

Three types of notes are used in this manual:

- **Note**  
Gives additional information or information particularly important to the procedure.
- **Caution**  
Indicates potential damage to equipment or data.
- **Warning**  
Indicates potential injury to a person.

**DECmpp 12000/Sx Introduction**

DECmpp 12000/Sx Series systems are powerful single-instruction, multiple data (SIMD) computers, consisting of a data parallel unit (DPU), which performs the parallel calculations, and a front-end server, running the ULTRIX operating system. A high-speed VMEbus interface carries data between the DPU and the front-end server.

The DPU contains the array control unit (ACU) printed circuit board (PCB) and from 1 to 16 processor element (PE) array PCBs. The ACU controls the PE arrays, which perform the parallel calculations. Each PE array PCB provides 1024 processor elements. The total collection of PE array PCBs in a system comprise the PE array.

DECmpp 12000 systems support 1, 2, 4, 8, or 16 PE array PCBs and have 15 I/O slots for optional I/O PCBs. The DPU is housed within an H9A00 series enclosure. DECmpp 12000 systems can be ordered with either a DECsystem 5900 server or a DECstation 5000/240 server. The DECsystem 5900 is contained within a separate H9A00 series enclosure. This configuration is illustrated in Figure 1-1. The DECstation 5000/240 is contained within two desktop boxes, one for the CPU and one for storage expansion. This configuration is illustrated in Figure 1-2.

DECmpp 12000-LC systems support 1, 2, or 4 PE array PCBs and have 5 I/O slots for optional I/O PCBs. The DPU is contained within a low profile cabinet and connects to a table-top DECstation 5000/240 server (Figure 1-3).

Any of the DECmpp 12000/Sx series system configurations may also contain an optional Parallel Disk Array (PDA). The PDA subsystem is housed in a separate H9A00 series enclosure.

---

**Warning**

---

Turning on power before you are instructed to do so can cause personal injury or damage to equipment.

---

**Figure 1-1 Typical DECmpp 12000/Sx Installation with DECsystem 5900 Server**

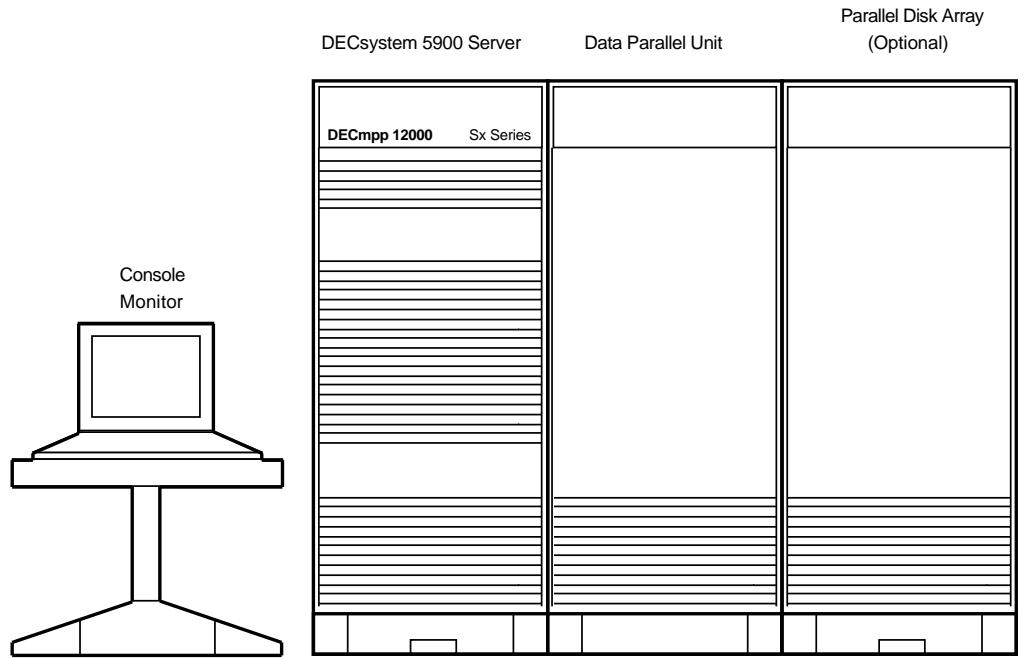

MKV-040000314-19-RAGS

**Figure 1-2 Typical DECmpp 12000/Sx Installation with DECstation 5000/240 Server**

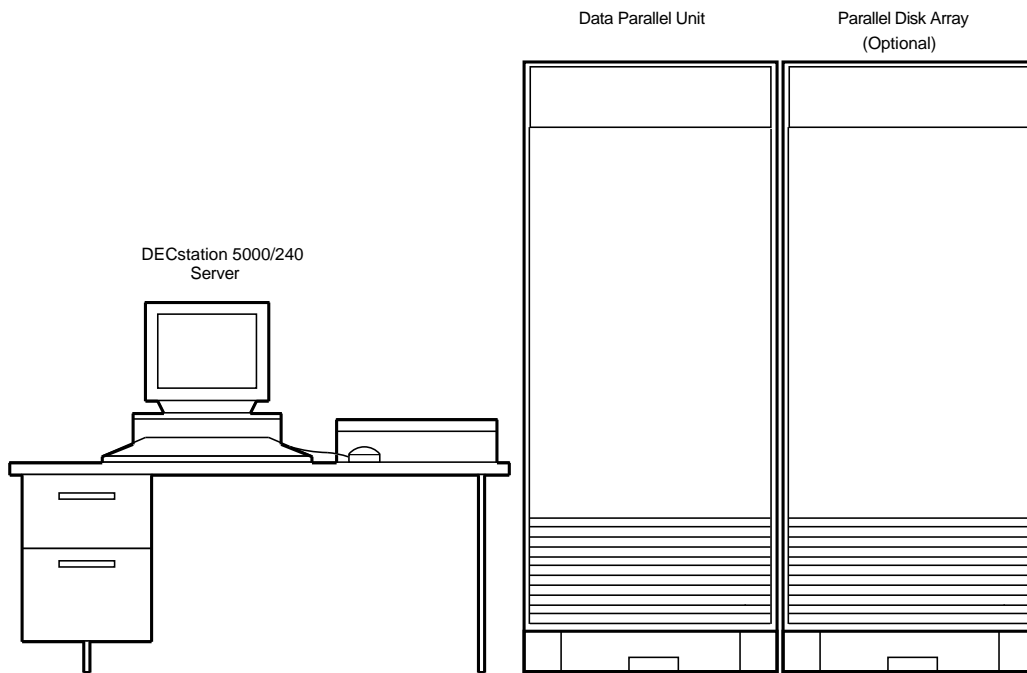

MKV-040000314-46-RAGS

**Figure 1-3 Typical DECmpp 12000-LC Installation**

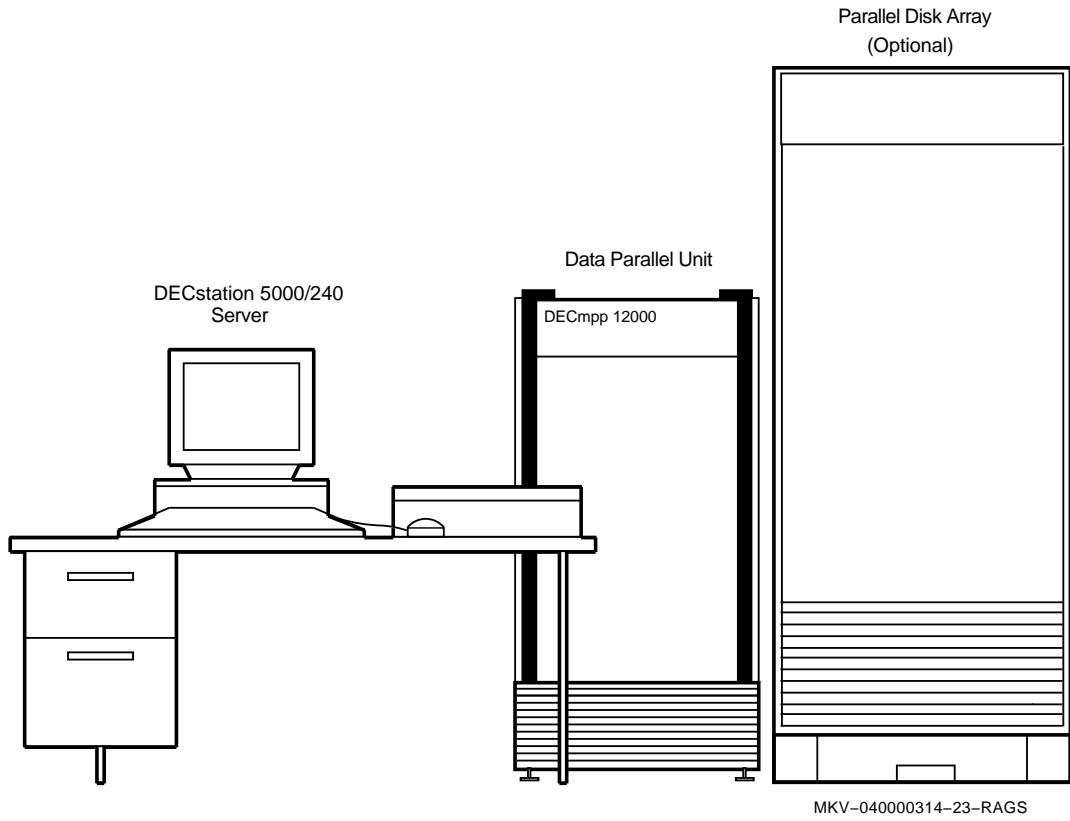



---

## Site Preparation

This chapter provides information about preparing a site for either the DECmpp 12000/Sx or DECmpp 12000-LC/Sx Series systems. It includes specifications and a physical description for all system configurations. Chapter 1 provides introductory material and naming conventions. Appendix C lists all DECmpp system variations and options.

When preparing a site for the DECmpp system, it is best to plan for the future and allow for equipment upgrades. For this reason, unless specifically stated otherwise, the specifications provided here are for fully configured systems with the maximum complement of PE array and I/O PCBs, disk drives, and front-end server options.

Refer to Section 2.1 for DECmpp 12000/Sx Site Preparation.

Refer to Section 2.2 for DECmpp 12000-LC/Sx Site Preparation.

Refer to Section 2.3 for Parallel Disk Array Site Preparation.

## 2.1 DECmpp 12000/Sx Site Preparation

### 2.1 DECmpp 12000/Sx Site Preparation

The following sections provide site preparation information for the DECmpp 12000/Sx system, including the DECsystem 5900 front-end server. If you are preparing a site for a DECmpp 12000/Sx system that uses the DECstation 5000/240 server, refer to Section 2.2 for server information. This section also contains information on the VRT19 high resolution color monitor.

#### 2.1.1 Physical Characteristics

Figure 2–1 shows the dimensions of each enclosure in the DECmpp 12000/Sx configuration.

##### 2.1.1.1 Size and Service Clearance

Space requirements include sufficient area to contain all of the equipment, and to provide service clearance. Leave at least 92 mm (36 inches) of clearance in the front and rear to access the DPU and DECsystem 5900 enclosures and to provide adequate ventilation. No space is required on the sides of the enclosure, though there must be some way to access the rear of all enclosures on a regular basis.

There must also be ample room for the power cables, network and other data cables, including the video cable that connects the video monitor to the DECsystem 5900. These should be out of the way, where they will not be stepped on, tripped over, or otherwise disturbed.

The dimensions of each enclosure are as follows:

- DECmpp 12000/Sx DPU and DECsystem 5900 enclosures (H9A00 series)  
170 cm high, 61 cm wide, 86.4 cm deep (66.9 inches high, 24.0 inches wide, 34.0 inches deep)  
The front door swings out with a 54 cm (22 inch) radius.
- VT420 video terminal dimensions  
31.2 cm high, 31.5 cm wide, 33.0 cm deep (12.3 inches high, 12.4 inches wide, 13.0 inches deep)  
Keyboard—4.5 cm high, 47.8 cm wide, 17.8 cm deep (1.8 inches high, 18.8 inches wide, 7.0 inches deep)

##### 2.1.1.2 Weight

The maximum weight for DECmpp 12000/Sx Series enclosures is:

- DECsystem 5900 enclosure—476 kg (1050 pounds)
- DPU enclosure—315 kg (694 pounds)  
DPU shipping weight—343 kg (756 pounds)
- VT420 video terminal weight including keyboard—9.9 kg (21.7 pounds)

---

#### Warning

---

Due to the weight of the equipment, Digital recommends that at least two people move the enclosures from shipping pallets to the final location.

---

## 2.1 DECmpp 12000/Sx Site Preparation

Figure 2-1 DECmpp 12000 Enclosure Dimensions

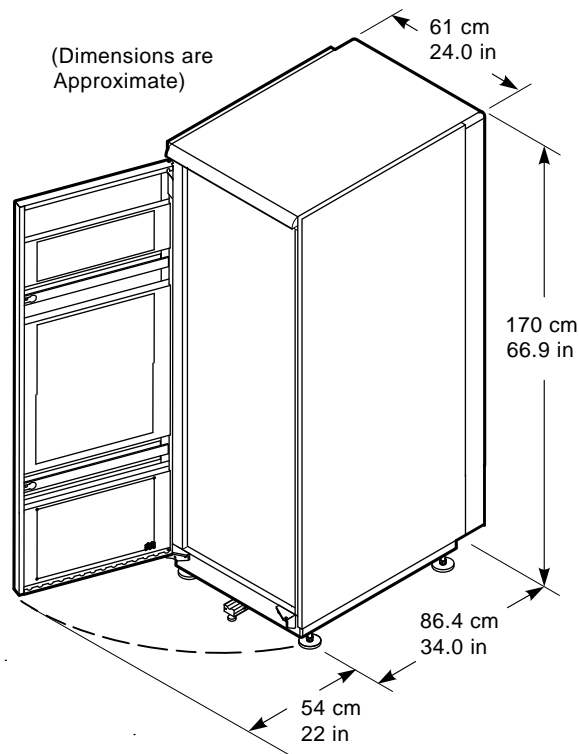

MKV-040000314-24-DG

### 2.1.2 Electrical Requirements

The DECmpp 12000/Sx system should be installed in a dedicated computer room. It requires two separate, dedicated power inputs, one for the DECsystem 5900 and one for the DPU. The power source should be adequate to handle the original system configuration and allow for system expansion. Additional power equipment may be required to avoid power disturbances.

Table 2-1 lists the electrical requirements for both the DECmpp DPU and the DECsystem 5900 server.

## 2.1 DECmpp 12000/Sx Site Preparation

**Table 2–1 DECmpp 12000/Sx Power Specifications**

<b>Item</b>	<b>DPU Power</b>	<b>DECsystem 5900 Power</b>
Nominal line voltage	220 Vac	230 Vac
Voltage range	180 Vac min, 264 Vac max	176 Vac min, 264 Vac max
Nominal frequency	50/60 Hz	50/60 Hz
Frequency range	47 Hz to 63 Hz	47 Hz to 63 Hz
Power source phase	Single	Single
Maximum steady state current at nominal voltage	30 A	12 A
Startup current (20 seconds)		16 A
Maximum inrush current		200 A
Maximum power consumption	5000 W	1630 W
Typical power	2000 W plus I/O	1630 W

## 2.1 DECmpp 12000/Sx Site Preparation

### 2.1.2.1 Cables

Power cables, 3 m (9 feet) long, are shipped attached to each DECsystem 5900 and DECmpp DPU enclosure. Each cable is terminated with a 30 A, 250 V twist lock connecting plug. Table 2–2 lists alternate power cables required by local country codes.

**Table 2–2 Alternate Cables**

<b>Country</b>	<b>Cable Number</b>
Australia	BN18D-4E 17-00198-05
Central Europe	BN18C-4E 17-00199-10
Denmark	BN18P-4E 17-01255-01
Europe	BN18P-4E 17-01255-01
India	BN18H-4E 17-00456-06
Ireland	BN18P-4E 17-01255-01
Israel	BN18F-4E 17-00457-06
Italy	BN18E-4E 17-00364-06
Japan	BN18R-4E 17-01256-01
South Africa	BN18H-4E 17-00456-06
Switzerland	BN18P-4E 17-01255-01
United Kingdom	BN18P-4E 17-01255-01
United States	BN18R-4E 17-01256-01

## 2.1 DECmpp 12000/Sx Site Preparation

### 2.1.3 Environmental Considerations

Computer systems, especially their storage devices, are adversely affected by particulate matter. The area must be free from dirt, dust and other environmental hazards.

#### 2.1.3.1 Cooling

Heat dissipation is measured in British Thermal Units (Btu). Maximum heat dissipation for the DECmpp 12000/Sx system is:

- DECsystem 5900 enclosure—5,325 Btu/h.
- DPU enclosure—17,100 Btu/h.

Cooling air flow for each H9A00 series cabinet is as follows:

- DECsystem 5900—Cool air enters through louvers in the front door, runs horizontally through the equipment and is exhausted out louvers in the rear door.
- DECmpp 12000/Sx DPU—Cool air enters through top louvers in the front door, runs vertically through the equipment and is exhausted out bottom louvers in the front and rear doors.

#### 2.1.3.2 Temperature and Humidity

Table 2–3 lists temperature and relative humidity values for the DECmpp 12000/Sx system.

**Table 2–3 DECmpp 12000/Sx Temperature/Humidity Specifications**

Parameter	Operating—DPU	Operating—DECsystem 5900	Non-operating
Temperature <sup>1</sup>	10°C to 32°C 50°F to 90°F	0°C to 32°C 32°F to 90°F	–40°C to 66°C –40°F to 151°F
Temperature rate of change		11°C per hour max 20°F per hour max	N/A
Relative humidity	20% to 80% (noncondensing)	20% to 80% (noncondensing)	10% to 95%
Maximum Wet Bulb Temperature	28°C 82°F		
Minimum Dew Point Temperature	2°C 36°F		
Maximum Altitude	2400 m (8000 ft) at 36°C 96°F	3000 m 10,000 ft	15,000 m 50,000 ft

<sup>1</sup>For operation above sea level, decrease the operation temperature by 1.8°C per 1000 m (or 1°F per 1000 ft).

## 2.1 DECmpp 12000/Sx Site Preparation

### 2.1.3.3 Static Electricity

Static electricity can cause system failure and loss of data. To minimize static buildup, follow these guidelines:

- Maintain relative humidity of at least 20%.
- Provide a separately fed electrical circuit for each enclosure ordered.
- Provide as many electrical outlets as required for each additional device, including the console video monitor and any other tabletop or network devices.

### 2.1.4 Additional Equipment

Make sure that there is enough space for terminals, monitors, and other peripheral equipment. When you plan cable routing, consider factors such as safety, convenience, future expansion, and cost. Cables for peripherals and networks should be in place and labeled before you install the system.

#### 2.1.4.1 Modem

DECmpp 12000/Sx systems shipped inside the United States have a built-in modem. To support the modem connection, you need a 2500-style (normal analog) telephone circuit and an X11 telephone cable.

#### 2.1.4.2 Ethernet

The DECsystem 5900 requires a standard thick wire Ethernet connection.

## 2.2 DECmpp 12000–LC/Sx Site Preparation

## 2.2 DECmpp 12000–LC/Sx Site Preparation

The following sections provide information about site preparation for the DECmpp 12000–LC/Sx system, including the DECstation 5000/240 front-end workstation.

### 2.2.1 Physical Characteristics

Figure 2–2 shows the dimensions of the DPU enclosure in the DECmpp 12000–LC/Sx configuration.

#### 2.2.1.1 Size and Service Clearance

Space requirements include sufficient area to contain all of the equipment, and to provide service clearance. Leave at least 92mm (36 inches) of clearance in the front and rear of the DPU enclosure for access and to provide adequate ventilation. No space is required on the sides of the enclosure, though there must be some way to access the rear of the enclosure on a regular basis.

Space for the DECstation 5000/240 should be sufficient to contain all of the equipment, including the CPU box, expansion box, monitor, keyboard, and mouse. Dimensions for each of the workstation parts are as follows:

- DECmpp 12000-LC DPU enclosure  
107 cm high, 47 cm wide, 82.5 cm deep (42 inches high, 18.5 inches wide, 32.5 inches deep)  
The front door swings out with a 36 cm (14 inch) radius.
- DECstation 5000/240 CPU or Expansion Box Dimensions  
9.19 cm high, 50.95 cm wide, 43.48 cm deep (3.62 inches high, 20.06 inches wide, 17.12 inches deep)
- VRT19 Video Monitor  
48.3 cm high, 48.3 cm wide, 50.8 cm deep (19.0 inches high, 19.0 inches wide, 20.0 inches deep)  
Keyboard—53.3 cm wide, 17.2 cm deep (21 inches wide, 6.75 inches deep)

There must also be ample room for the power cables and data cables, including the cable that connects the DECstation to the DECmpp 12000–LC enclosure. These should be out of the way, where they will not be stepped on, tripped over, or otherwise disturbed.

#### 2.2.1.2 Weight

The maximum weight for DECmpp 12000–LC/Sx Series enclosures is:

- DPU enclosure—182 kg (400 pounds)
- DECstation 5000/240 CPU box—12.7 kg (28 pounds)
- DECstation 5000 expansion box—21.8 kg (46 pounds)
- VRT19 video monitor weight—32.7 kg (72 pounds)

## 2.2 DECmpp 12000–LC/Sx Site Preparation

Figure 2–2 DECmpp 12000-LC/Sx DPU Enclosure Dimensions

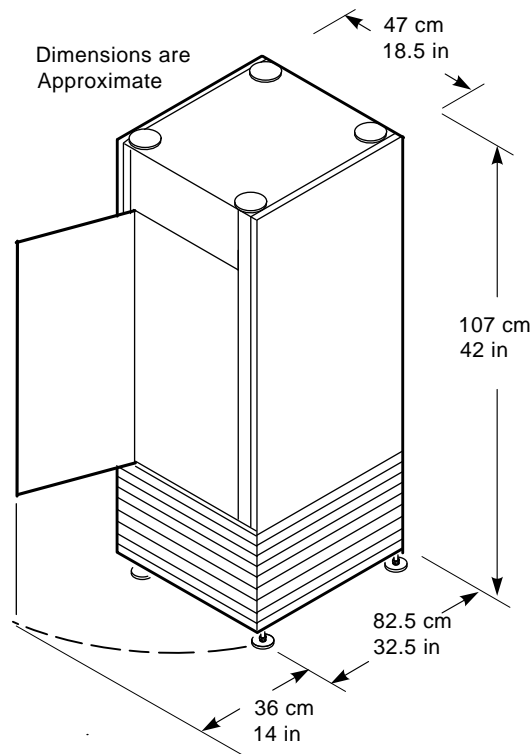

MKV-040000314-25-DG

### 2.2.2 Electrical Requirements

The DECmpp 12000–LC/Sx system requires two separate, dedicated power inputs, one for the DECstation and one for the DPU. The power source should be adequate to handle the original system configuration and allow for system expansion. Additional power equipment may be required to avoid power disturbances.

Table 2–4 lists the electrical requirements for both the DECmpp 12000-LC DPU and the DECstation 5000/240 workstation.

## 2.2 DECmpp 12000–LC/Sx Site Preparation

**Table 2–4 DECmpp 12000-LC/Sx Power Specifications**

Item	DPU Power	DECstation 5000/240 Power
Nominal line voltage	110 Vac/220 Vac	110 Vac/220 Vac
Voltage range	90 Vac min, 132 Vac max 180 Vac min, 264 Vac max	88 Vac min, 132 Vac max 176 Vac min, 264 Vac max
Nominal frequency	50/60 Hz	110 Vac—60 Hz 220 Vac—50/60 Hz
Maximum steady state current at nominal voltage	110 Vac—15 A 220 Vac—10 A	110 Vac—9.5 A 220 Vac—5.3 A
Maximum power consumption	1000 W	1630 W including I/O
Typical power	500 W plus I/O	1630 W including I/O

### 2.2.2.1 Cables

A 3 m (10 ft) long power cable is shipped attached to the DPU enclosure. For 110 Vac systems, the cable is terminated with a NEMA 5-15P connecting plug. For 220 Vac systems, the cable is terminated with a NEMA 6-15P connecting plug.

### 2.2.3 Environmental Considerations

Computer systems, especially their storage devices, are adversely affected by particulate matter. The area must be free from dirt, dust and other environmental hazards.

#### 2.2.3.1 Cooling

The DECmpp 12000–LC/Sx system does not require a special room; it operates in an air-conditioned office environment. However, the parallel disk array (PDA) option requires a Class A computer room environment. Therefore, if a configuration includes the PDA, both enclosures should be kept in the computer room.

Heat dissipation is measured in British Thermal Units (Btu). Maximum heat dissipation for the DECmpp 12000–LC/Sx DPU is 4100 Btu/h.

## 2.2 DECmpp 12000–LC/Sx Site Preparation

### 2.2.3.2 Temperature and Humidity

Table 2–5 lists temperature and relative humidity values for the DECmpp 12000–LC/Sx system.

**Table 2–5 DECmpp 12000-LC/Sx Temperature/Humidity Specifications**

Parameter	Operating—DPU	Operating—DECstation 5000/240	Non-operating
Temperature <sup>1</sup>	10°C to 38°C 50°F to 104°F	0°C to 40°C 32°F to 104°F	
Temperature rate of change			N/A
Relative humidity	20% to 80% (noncondensing)	20% to 80% (noncondensing)	
Maximum Wet Bulb Temperature	28°C 82°F	28°C 82°F	
Minimum Dew Point Temperature	2°C 36°F	2°C 36°F	
Maximum Altitude	2400 m (8000 ft) at 36°C 96°F	2400 m (8000 ft) at 36°C 96°F	15,000 m 50,000 ft

<sup>1</sup>For operation above sea level, decrease the operation temperature by 1.8°C per 1000 m (or 1°F per 1000 ft)

### 2.2.3.3 Static Electricity

Static electricity can cause system failure and loss of data. To minimize static buildup, follow these guidelines:

- Maintain relative humidity of at least 20%.
- Provide a separately fed electrical circuit for each enclosure ordered.
- Provide as many electrical outlets as required for each additional device, including the expansion box, console video monitor, and any other tabletop or network devices.

## 2.2.4 Additional Equipment

Make sure that there is enough space for terminals, monitors and other peripheral equipment. When you plan cable routing, consider factors such as safety, convenience, future expansion, and cost. Cables for peripherals and networks should be in place and labeled before you install the system.

### 2.2.4.1 Modem

DECmpp 12000–LC/Sx systems shipped inside the United States have a built-in modem. To support the modem connection, you need a 2500-style (normal analog) telephone circuit and an X11 telephone cable.

### 2.2.4.2 Ethernet

The DECstation 5000/240 requires a standard thick wire Ethernet connection.

## 2.3 Parallel Disk Array Site Preparation

### 2.3 Parallel Disk Array Site Preparation

The following sections provide information to help you prepare a site for a Parallel Disk Array (PDA). It includes specifications and a physical description of the PDA enclosures.

The DECmpp 12000/Sx Parallel Disk Array (PDA) provides a parallel, multidisk architecture, consisting of a disk array (DA) controller and a parallel disk array providing bulk data storage. The disk array comprises 5-1/4 inch ESDI disk drives, arranged in banks of 4, 8, or 16 data disks, with up to two associated parity disks and one "hot" standby disk. The disk array is a scaleable I/O device for bulk data storage. The integral DA controller provides a high-speed data connection to the disk array. A VME control port allows an external VME agent to perform additional basic control functions. A diagnostic port allows for debugging. Front panel indicators provide status for both system power and individual disk drives.

#### 2.3.1 Physical Characteristics

Physical characteristics include size, service clearance and weight.

##### 2.3.1.1 Size and Service Clearance

The PDA is housed in a separate H9A00 series enclosure which is electrically connected to the data parallel unit (DPU). The PDA enclosure is identical to the enclosures that house the DECsystem 5900 server and the DECmpp 12000/Sx DPU. Refer to Figure 2-1 for the overall dimensions of this enclosure.

As with the DPU enclosure, space requirements include sufficient area to contain all of the equipment, and to provide service clearance. Leave at least 92 mm (36 inches) of clearance in the front and rear to access the PDA enclosure and to provide adequate ventilation. No space is required on the sides of the enclosure, though there must be some way to access the rear of the enclosure on a regular basis. There must also be ample room for the power cable, which should be out of the way, where it will not be stepped on, tripped over, or otherwise disturbed.

##### 2.3.1.2 Weight

The maximum weight for DECmpp PDA enclosure is 378 kg (834 pounds). The PDA shipping weight is 411 kg (906 pounds).

---

#### Warning

---

Due to the weight of the equipment, Digital recommends that at least two people move the enclosure from the shipping pallet to the final location.

---

## 2.3 Parallel Disk Array Site Preparation

### 2.3.2 Power and Cooling Requirements

The PDA enclosure for all DECmpp 12000/Sx series configurations should be installed next to the DPU enclosure; both should be in a controlled computer room environment. The area must be free of dust, and other environmental hazards.

Cooling air flow for PDA H9A00 series cabinet is such that cool air enters through top louvers in the front door, runs vertically through the equipment, and is exhausted out bottom louvers in the front and rear doors.

All DECmpp configurations require that the PDA be tied to a dedicated power input.

Power requirements for all SMP11-Ax models is as follows:

20A, 220 V/240 V outlet (supports up to 19 disks)

All SMP11-Ax PDA enclosures are shipped with an L6-20P three-prong AC plug. If you are not certain about your power source, contact a qualified electrician.

### 2.3.3 Power and Environmental Specifications

Table 2–6 provides the PDA electrical and environmental specifications.

**Table 2–6 PDA Specifications**

Item	Specification
Line Voltage	220/240 VAC, 20A, 50/60 Hz, single phase
Line Voltage Tolerance for 220 V	180 V minimum, 264 V maximum
Maximum Power	2500 W
Operating Temperature	10–40°C (50–104°F)
Humidity	20–80% noncondensing
Maximum Wet Bulb Temperature	28°C (82°F)
Minimum Dew Point Temperature	2°C (36°F)
Maximum Altitude	2400 m (8000 ft) at 36°C (96°F)
Cooling Requirement	4270 Btu/hour (up to 10 disks), 8540 Btu/hour (more than 10 disks)



---

## System Hardware Installation

### 3.1 Installation Overview

As outlined in Chapter 1, all DECmpp 12000/Sx systems consists of a data parallel unit (DPU), an ULTRIX server functioning as a front-end processor, and an optional Parallel Disk Array.

The DECmpp 12000/Sx system employs either the DECsystem 5900 server or the DECstation 5000/240 server. In this configuration, the DPU is contained within an H9A00 series enclosure. The server may also be housed in a separate H9A00 series enclosure (DECsystem 5900) or a pair of tabletop boxes (DECstation 5000/240).

The DECmpp 12000-LC/Sx DPU employs the DECstation 5000/240 server. In this configuration, the DPU is contained within a short enclosure and the server in a pair of tabletop boxes.

Either system configuration can also contain an optional Parallel Disk Array (PDA). The PDA is housed within a separate H9A00 series enclosure.

This chapter provides instructions for physical installation, cabling, and initial powerup of the system. Installation procedures for the ULTRIX server are located in either the *DECsystem 5900 Installation Guide*, or the *DECstation 5000 Hardware Installation Guide*, depending on your configuration. Parallel disk array installation procedures are located in the *DECmpp 12000/Sx Parallel Disk Array Reference Manual*. When all installation procedures are completed, the system can be booted and operated. Appendix A contains a brief installation checklist, without the details provided here.

---

#### Warning

---

Turning on power before you are instructed to do so can cause personal injury or damage to equipment.

---

Remember, if you need assistance during the installation, call:

#### **CUSTOMER SUPPORT CENTER**

**1-800-354-9000** (U.S. and Canada)

Ask for DECmpp support

## 3.2 Unpacking and Inspection

### 3.2 Unpacking and Inspection

The shipment consists of several packages. The content of the packages depends largely upon the system configuration and options ordered. The largest boxes on shipping skids may contain the DECmpp 12000/Sx DPU, DECsystem 5900 and optional PDA. Other smaller boxes may contain the DECstation 5000, video display, accessories (tapes, cables, keyboard, and manuals) and any items packaged separately for special protection (for example, printed circuit boards (PCBs) for the DPU).

If you are installing a DECmpp 12000/Sx system, proceed to Section 3.2.1.

If you are installing a DECmpp 12000-LC/Sx system, proceed to Section 3.2.2.

#### 3.2.1 Unpacking and Positioning the DECmpp 12000/Sx Server

If you are installing a DECmpp 12000/Sx system with a DECsystem 5900 server, refer to the unpacking instructions in the *DECsystem 5900 Installation Guide*. Then position the DECsystem 5900 enclosure as the leftmost enclosure in the configuration as viewed from the front in Figure 1-1 of this manual. Install the DECsystem enclosure side panels as part of the enclosure installation procedure. Do not install the enclosure skirts at this point.

If you are installing a DECmpp 12000/Sx system with a DECstation 5000/240 server, refer to the unpacking instructions in the *DECstation 5000 Hardware Installation Guide*. Figure 1-2 of this manual shows a typical installation.

After unpacking the server, proceed to Section 3.2.3.

#### 3.2.2 Unpacking and Positioning the DECmpp 12000-LC/Sx Server

If you are installing a DECmpp 12000-LC/Sx system, it includes a DECstation 5000 server. Instructions for unpacking the DECstation 5000 are in the *DECstation 5000 Hardware Installation Guide*.

After unpacking the server, proceed to Section 3.2.4.

### 3.2.3 Unpacking and Positioning the DECmpp 12000/Sx DPU

Follow these steps to unpack the DPU:

1. Inspect the container for obvious signs of damage, including dents, scrapes, or water damage. If you find any sign of damage, note this on the bill of lading.
2. Remove the plastic wrap, the corner pads, and any cardboard packaging.

---

**Note**

---

Leave a minimum of 7 ft clearance in front of the shipping skid.

---

3. Insert the skid ramps into the holes in the front of the skid with arrows on skid lined up with arrows on ramp boards.
4. With a 9/16-inch wrench, loosen and remove the shipping bracket bolts ❶ on the enclosure feet (Figure 3-1).
5. Remove the shipping brackets ❷ and save them for use if the enclosure needs to be reshipped.

**Figure 3-1 Removing Enclosure Shipping Bracket**

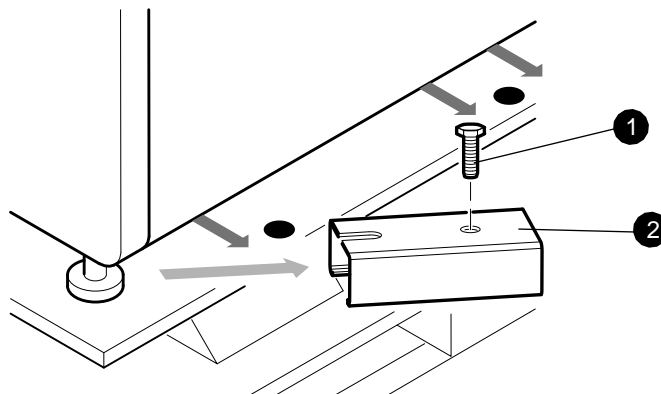

MLO-007680

- ❶ Shipping bracket bolts
- ❷ Shipping bracket

6. While the enclosure is still on the skid, loosen the 3/4-inch upper (lock) nut on each foot by turning clockwise (Figure 3-2). Turn the 9/16-inch bottom nut on each foot counterclockwise to raise the feet for skid clearance.

## 3.2 Unpacking and Inspection

Figure 3–2 DECmpp 12000/Sx DPU Enclosure Levelers

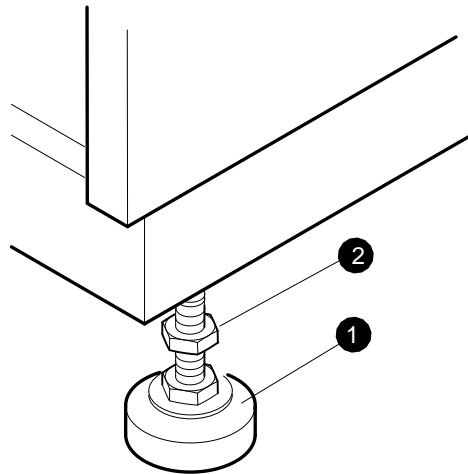

MLO-007745

---

### Warning

---

The DPU enclosure weighs 315 kg (694 pounds). For safety, two people are needed to roll the enclosure down the ramps.

---

7. Roll the enclosure down the ramp boards. The front two wheels are on swivel casters, the rear two are fixed.
8. Ensure that both enclosure side panels are installed and secure.
9. If you are installing the DPU with a DECsystem 5900 server, position the DPU enclosure to the right (facing front) of the server enclosure.  
If you are installing the DPU with a DECstation 5000/240 server, position the DPU enclosure in close proximity to the server boxes.
10. Leave 36-inch clearance at the front and rear of the enclosure for service.

---

### Caution

---

**All enclosure side panels must be installed.** This is important to maintain proper cooling air flow and to reduce radiated emissions.

---

11. Raise the enclosure up on its feet as follows:
  - a. Loosen the 3/4-inch lock nut (clockwise) on each foot.
  - b. Lower each foot into position by turning clockwise on the 9/16-inch nut on the foot.
  - c. Tighten each 3/4-inch locknut counterclockwise to lock the feet in place.
12. Ensure that the DPU and DECsystem 5900 enclosures are leveled such that their side panels butt against each other firmly with no gap. Also, ensure that the height of all enclosures is identical so that horizontal lines are in alignment.

## 3.2 Unpacking and Inspection

### 3.2.3.1 Assembling the Enclosure Skirts

Open the DPU enclosure skirt kit, PN H9C00-UA. The DECsystem 5900 has a similar kit.

The skirts are installed after all enclosures are installed and raised up off their casters by the leveling feet.

A separate skirt is installed on each side of the enclosure except the sides that butt up against another enclosure. Each skirt is attached to the enclosure by two quarter-turn Phillips head captive screws.

#### Front Skirt

The front skirt, shown in Figure 3–3, has three pieces, ❶ (two each) and ❷, that must be fitted together, then attached to the enclosure.

Figure 3–3 Front and Side Skirts

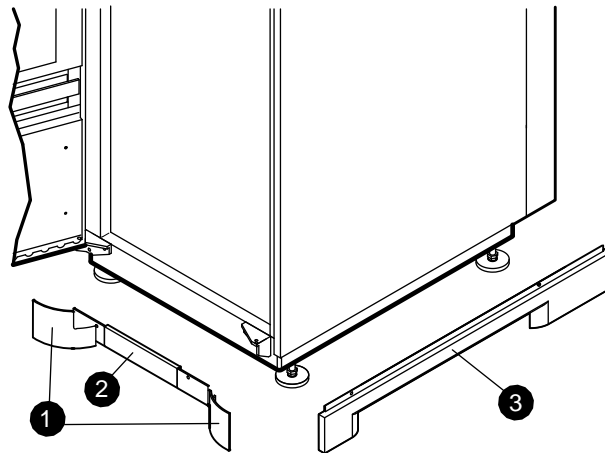

MKV-040000314-32-DG

- ❶ Front curved pieces, PN 70-29318-01, and PN 7-29318-02
- ❷ Front center piece, PN 74-41733-01
- ❸ Right side piece, PN 70-29320-02 (left side piece, PN 70-29320-01)

#### Side Skirts

One side skirt is shown in Figure 3–3, item ❸. Attach the side skirt(s) to the side(s) of the enclosure frame that do not butt up against another enclosure.

## 3.2 Unpacking and Inspection

### Rear Skirt

The center piece of the rear skirt has a rectangular opening through which run all external power and signal cables. The rear skirt panels are shown in Figure 3–4.

The curved pieces, ❶ and ❸, are attached to the center piece ❷ with plastic push-in fasteners, and attached to the frame with the push-in captive screws. The cable cover, PN 74-41660-00, (not shown in Figure 3–4), fits into the notches on the two side pieces.

Figure 3–4 Rear Skirt

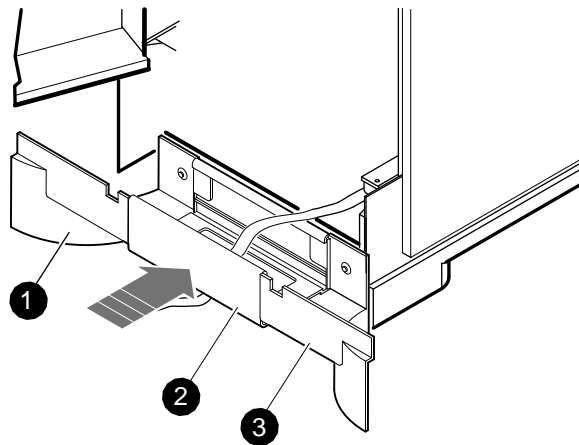

MKV-04000314-33-DG

❶ PN 70-29318-01

❷ PN 74-41733-01

❸ PN 70-29318-02

After installing the skirts, proceed to Section 3.3.

### 3.2.4 Unpacking and Positioning the DECmpp 12000–LC/Sx DPU

Figure 3–5, Figure 3–6, Figure 3–7, and Figure 3–8 show the unpacking procedure. Follow these steps to unpack the DPU:

Inspect the container for obvious signs of damage, including dents, scrapes, or water damage. If you find any sign of damage, note this on the bill of lading.

Warning devices on the shipping container show if it was subjected to shock or tipped over. Another set of indicators is inside the container, on the DPU front panel. Inspect the outside indicators on receipt of the system. If the outside indicators are missing, unpack the system *immediately*, and inspect the inside set. Note any signs of shock or tipping on the bill of lading.

- The Shockwatch indicator is a bright yellow and white square with a small, white vial in the center. If the vial is red instead of white, the container has been subjected to shock. Usually, this means that the box was dropped.
- The Tip-n-Tell is an orange square with an inverted "V" in the center. The bottom half of the "V" contains small blue particles; the top is light brown. If any of the blue particles are in the top of the "V," the shipping container was tipped.

If you find any sign of damage, or if any of the indicators show that the package was shocked or tipped, note this on the bill of lading.

Figure 3–5 shows the bands and the ramp.

---

#### Warning

---

The plastic bands are under tension and can snap or rebound when cut. Also, the ramp can fall when the bands and securing tape are cut.

---

## 3.2 Unpacking and Inspection

Figure 3–5 Unopened Shipping Container

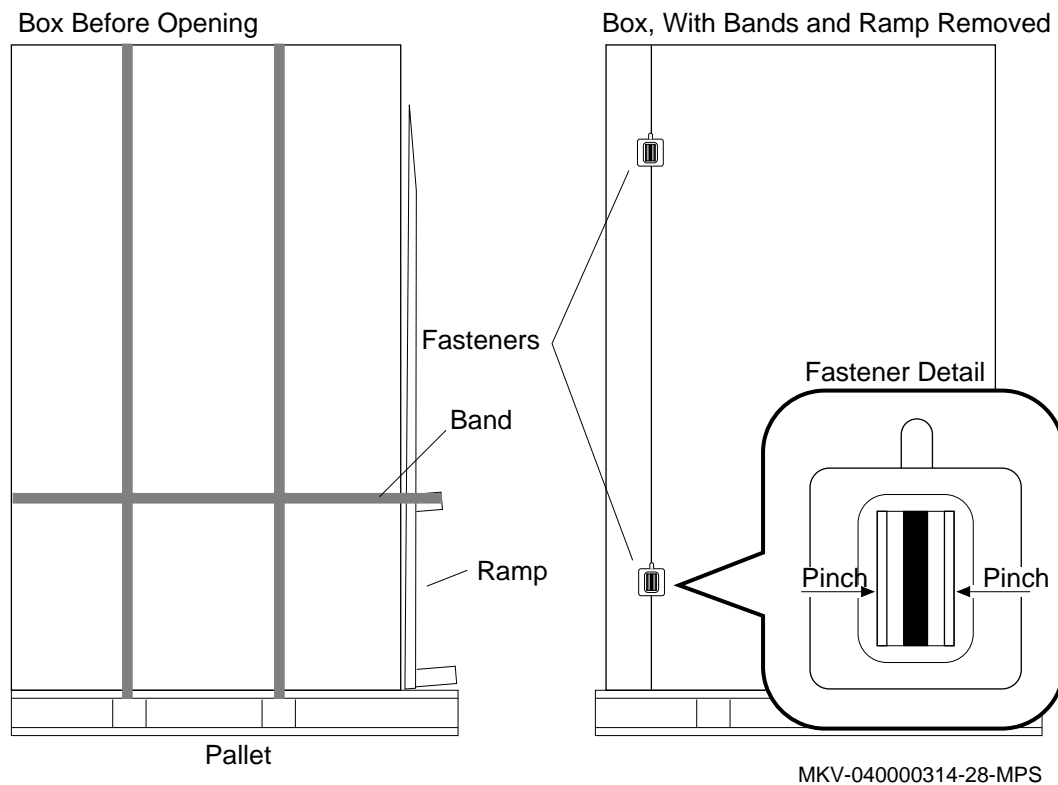

1. Use scissors or a knife to cut the plastic bands around the box.
2. While holding the ramp in place, cut the tape securing it to the side of the box.
3. Remove the ramp from the pallet and put it aside.
4. Remove the cardboard box.

---

### Caution

---

To avoid damage to the DPU, use a knife that does not penetrate more than 1 inch.

---

- a. Cut the tape along the seams on the top of the box.
  - b. Locate the seam running down the side of the shipping carton. There are two fasteners along this seam.  
Release these fasteners by squeezing or pinching the two flaps together until the fastener releases the cardboard. Figure 3–5 shows the fastener locations.
  - c. Once the tape is cut and the fasteners are released, pull the box away from the DPU.
5. The DPU is now sitting on a pallet with boards around its base. Latches hold one of these boards in place, as shown in Figure 3–6.

## 3.2 Unpacking and Inspection

Open each latch by flipping its key, or handle, up so that it stands straight out, then turning it 1/4 turn counterclockwise. This releases the board.

**Figure 3–6 Removing the Front Board**

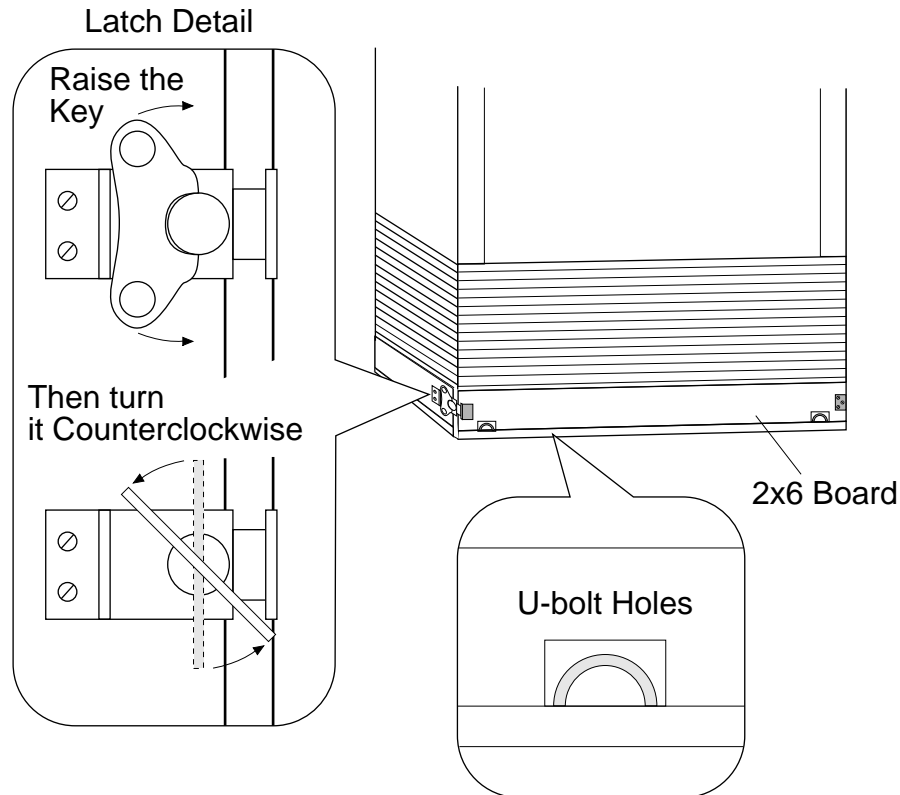

MKV-040000314-29-MPS

6. Remove this board and place it aside, exposing the two U-bolts inserted in the pallet.
7. Lay the ramp against this side of the pallet so that the top of the ramp (wide end) is flush with the surface of the pallet.
8. The two U-bolts in the pallet are used to fasten the ramp to the pallet. Lift out the U-bolts, and locate the matching holes at each side of the ramp and the pallet. Lower one U-bolt into each set of holes, straddling the gap between the ramp and the pallet. This connects the ramp and the pallet. Figure 3–6 shows the U-bolt locations, and Figure 3–7 shows the U-bolts in the ramp. The U-bolts are not bolted into place; their own weight holds them in.
9. The ramp is now ready. Carefully roll the DPU off the pallet and down the ramp.

## 3.2 Unpacking and Inspection

Figure 3-7 Ramp Ready to Use

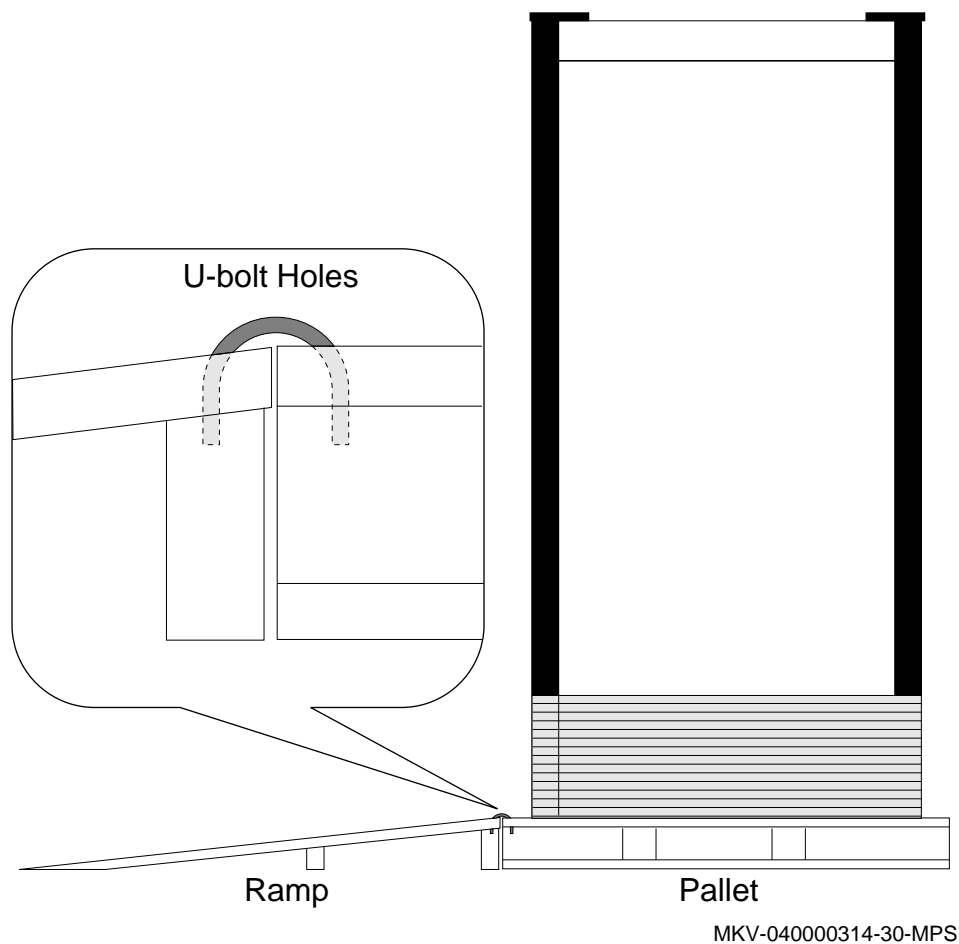

10. Gently push the DPU into position. It should be close to the DECstation 5000 CPU box.
11. Set the levelers at each bottom corner of the enclosure. Spin each leveler down until it sits firmly against the floor, as shown in Figure 3-8.

Figure 3-8 Setting the Levelers

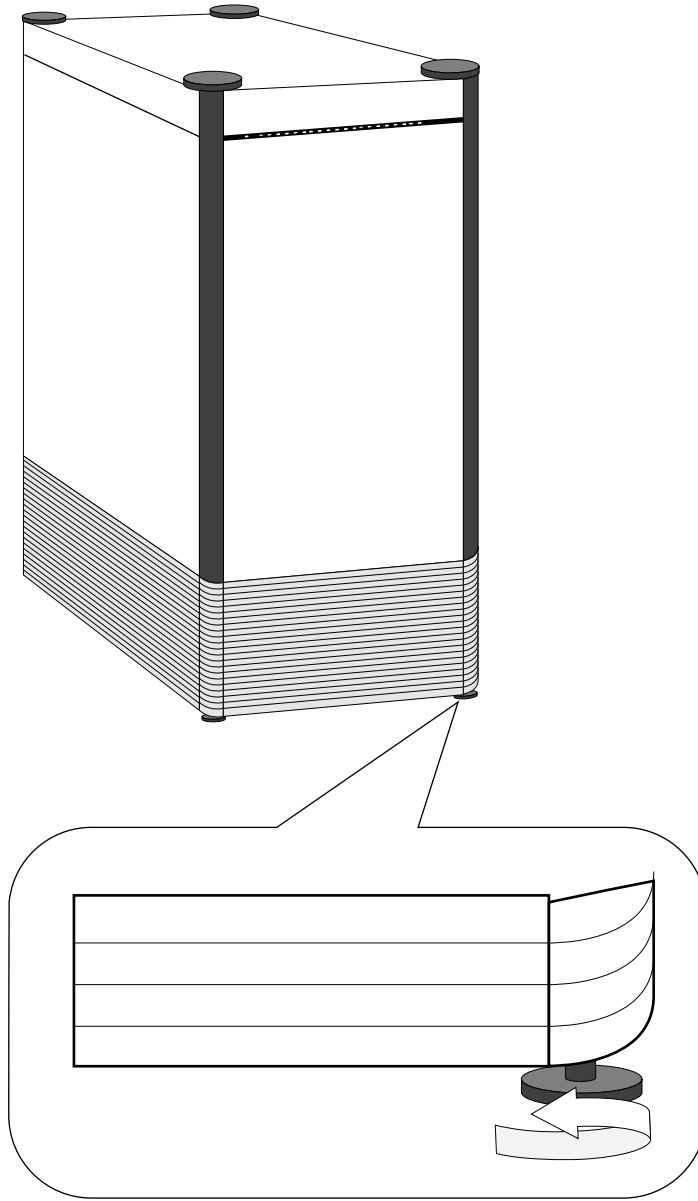

MKV-04000314-31-MPS

### 3.3 Front-End Server Installation

### 3.3 Front-End Server Installation

You should install the front-end server and verify its operation before beginning the DPU installation.

#### 3.3.1 Installing the DECsystem 5900

Follow these steps to install the DECsystem 5900:

1. Install the DECsystem as described in detail in the *DECsystem 5900 Installation Guide*. (You received a copy with the DECsystem.) Installation involves setting up and cabling the video terminal or monitor, keyboard, mouse, and network connection, and applying power.

Refer to Figure 3–9 for a view of the DECsystem 5900 Power Controller.

2. Ensure that the Remote/Local switch **1** is in the Remote position.
3. Turn the circuit breaker **2** on.

Refer to Figure 3–10 for a front view of the DECsystem 5900 CPU drawer.

4. Turn on the DECsystem with the system power switch **1** to verify correct installation. This also initiates the powerup self-test described in the *DECsystem 5900 Installation Guide*.
5. Turn off the DECsystem before beginning the DPU installation procedures.

Figure 3–9 DECsystem 5900 Power Controller

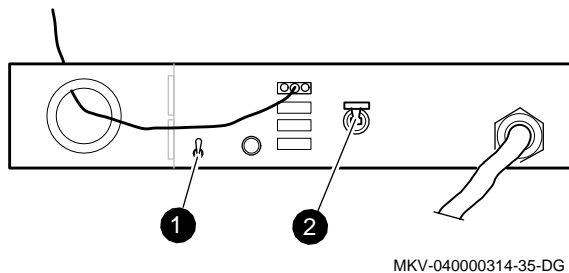
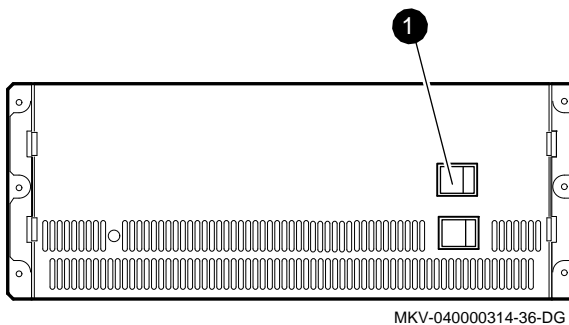

Figure 3–10 DECsystem 5900 System Power Switch



### 3.3.2 Installing the DECstation 5000

Follow these steps to install the DECstation 5000:

1. Install the DECstation, as described in detail in the *DECstation 5000 Hardware Installation Guide*. (You received a copy with the DECstation.) Installation involves setting up and cabling the CPU box, video monitor or terminal, storage expansion box, optical disk reader, keyboard, mouse and network connection, and applying power.
2. Turn on the DECstation to verify correct installation. This also initiates the powerup self-test described in the *DECstation 5000 Hardware Installation Guide*.
3. Turn off the DECstation before beginning the DPU installation procedures.

### 3.4 Data Parallel Unit Installation

---

**Warning**

---

Turning on DPU power before you are instructed to do so can cause injury or damage equipment.

---

Installation consists of the following major steps:

1. Installing PCBs
2. Installing interconnecting cables
3. Installing AC power cables
4. Turning on and booting the system

## 3.4 Data Parallel Unit Installation

### 3.4.1 Handling PCBs Correctly

To avoid damage, always handle a PCB correctly:

- Wear antistatic equipment (wrist or ankle strap) when handling the PCB.
- Use a static-free surface whenever working on a PCB.
- Handle the PCB gently by the edges.
- Never handle a PCB by the component or etched surfaces.
- Always store PCBs in a static-proof envelope.

Each PCB in the DPU card cage has ejector levers on the top and bottom of the PCB faceplate, shown in Figure 3–11. Filler panels are used to aid in cooling flow and do not have ejector levers.

Always use the ejector levers when installing PCBs as follows:

1. To release the PCB, lift up the lower end of the top lever, and press down on the upper end of the bottom lever, moving the PCB partially out of its slot.
2. To secure the PCB in the card cage slot, press in on both the ends of the top and bottom levers.

**Figure 3–11 PCB Ejector Levers**

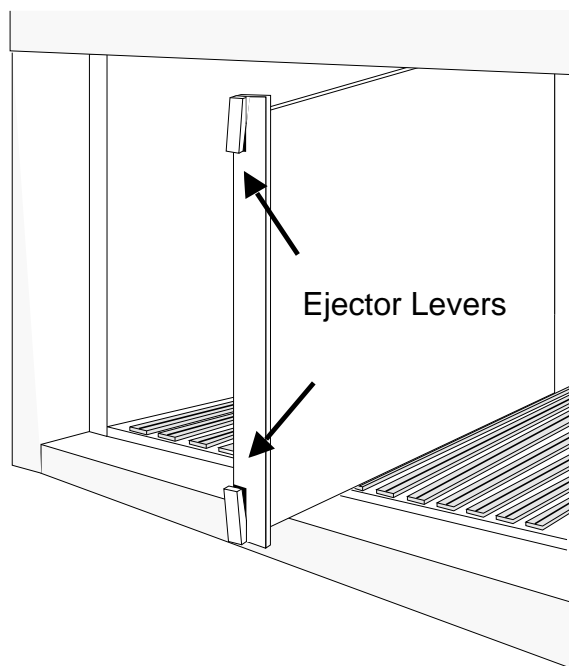

MKV-040000314-37-MPS

### 3.4.2 Data Parallel Unit PCBs

The DECmpp 12000/Sx DPU is shipped with all PCBs installed.

The DECmpp 12000-LC/Sx DPU is shipped with router PCBs installed, but with the following packaged separately:

- ACU PCB
- Parallel VME 6U Adapter with Front-end VME interface PCB (MVIB)
- PE array PCB(s)

The sections below provide installation procedures for these PCBs.

---

**Note**

---

If an optional PDA is to be installed, the Parallel VME 6U Adapter PCB with disk interface controller must be installed independently.

---

#### 3.4.2.1 Array Control Unit Jumper Settings

Before beginning the installation, verify the factory-installed ACU PCB jumper settings, as shown in Figure 3–12; the darkened blocks indicate jumpers that are normally installed.

Table 3–1 shows the function of the ACU jumpers and their factory settings.

**Table 3–1 ACU Jumper Settings**

Jumper Function	Factory Setting
ACU VMEbus address	0xFCC000000
ACU VMEbus interrupt request level	Level 1
ACU VMEbus interrupt acknowledge level	Level 1
Independent scan path selection from the server (for diagnostics only)	Off
Selection of ACU as a VMEbus arbiter	ACU VMEbus arbiter selected
16-bit or 32-bit word selection for ACU instruction DMA	32-bit
Block or pipelined mode for ACU instruction DMA	Pipelined
IMem size	1 MB
ACU PCB clock enable/disable	Enabled

### 3.4.3 Data Parallel Unit Card Cage Access

The ACU, PE array, front end VME interface, and router PCBs are accessed through the DPU rear door. Figure 3–13 shows the DECmpp 12000/Sx card cage access. The DECmpp 12000-LC/Sx DPU has similar access.

### 3.4 Data Parallel Unit Installation

Figure 3–12 Array Control Unit Jumpers

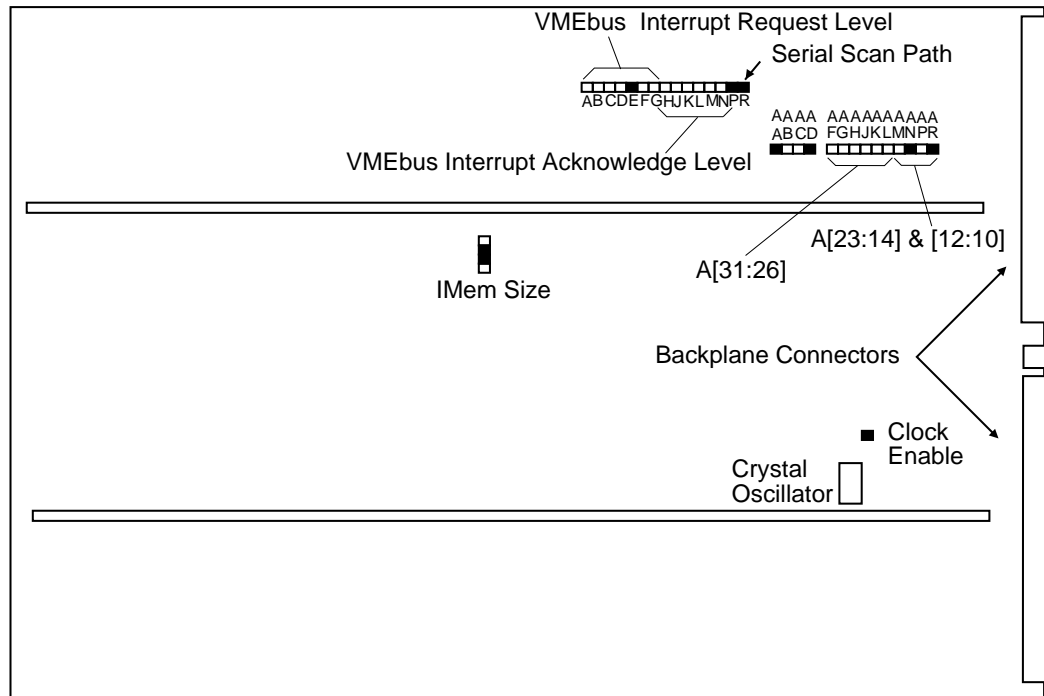

Note: Darkened Jumpers are INSTALLED.

MKV-040000314-38-MPS

To open the DPU rear door, use the 5/16 inch hex wrench supplied with the system.

#### 3.4.3.1 Data Parallel Unit Card Cage Slots

The DPU card cage is divided into two dedicated blocks: one for I/O PCBs and the other for PE array and router PCBs as shown in Figure 3–14.

In the I/O section, the first slot on the left always holds the ACU PCB. The second I/O slot is configured to support the Front-end VME interface (MVIB). The other slots are for I/O or VMEbus PCBs mounted on a Parallel VME 6U Adapter PCB.

The PE array PCBs must be in contiguous slots, starting with the first PE array slot on the left. If the number of PE array PCBs changes, the system must be rejumped, as described in the *DECmpp 12000/Sx Hardware Service Manual*, "Upgrading Processor Element Arrays" chapter.

#### Note

All PE array PCB slots that do not contain a PE array PCB *must* contain a router PCB. The DECmpp 12000/Sx and DECmpp 12000–LC/Sx systems will not work if any PE array slot is empty.

### 3.4 Data Parallel Unit Installation

Figure 3-13 DECmpp 12000/Sx System and Card Cage (Rear View)

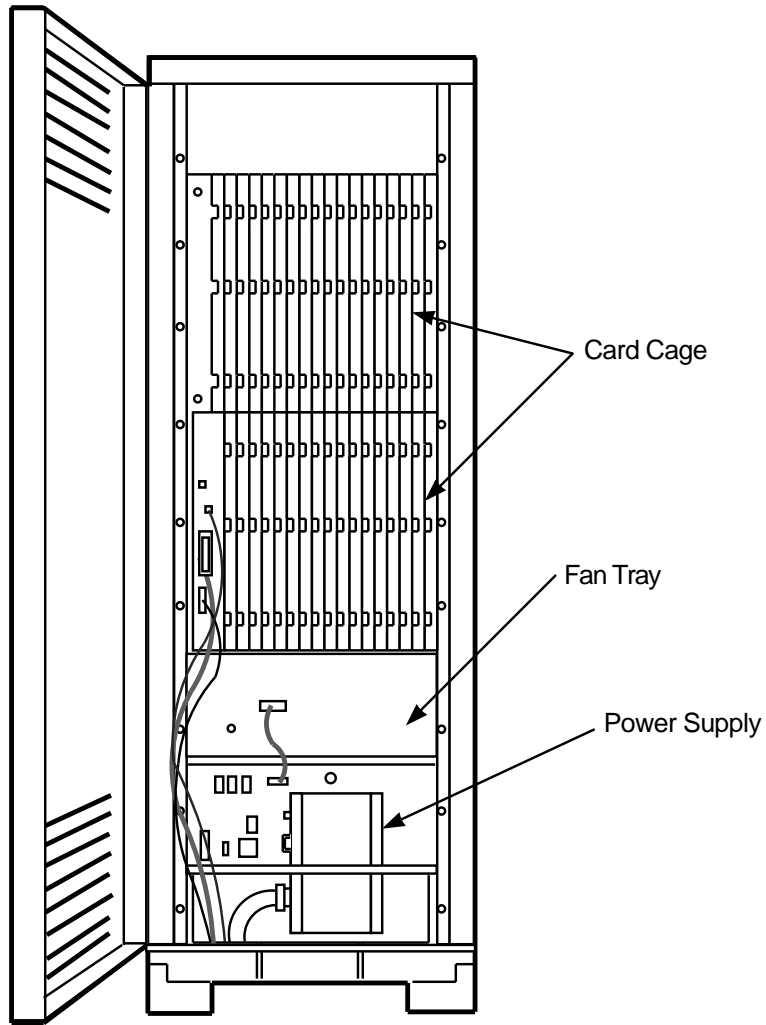

MKV-040000314-59-RAGS

### 3.4 Data Parallel Unit Installation

Figure 3-14 Data Parallel Unit Card Cage Slots

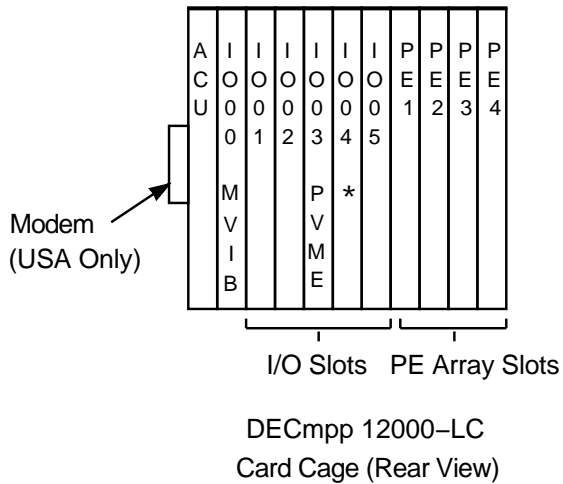
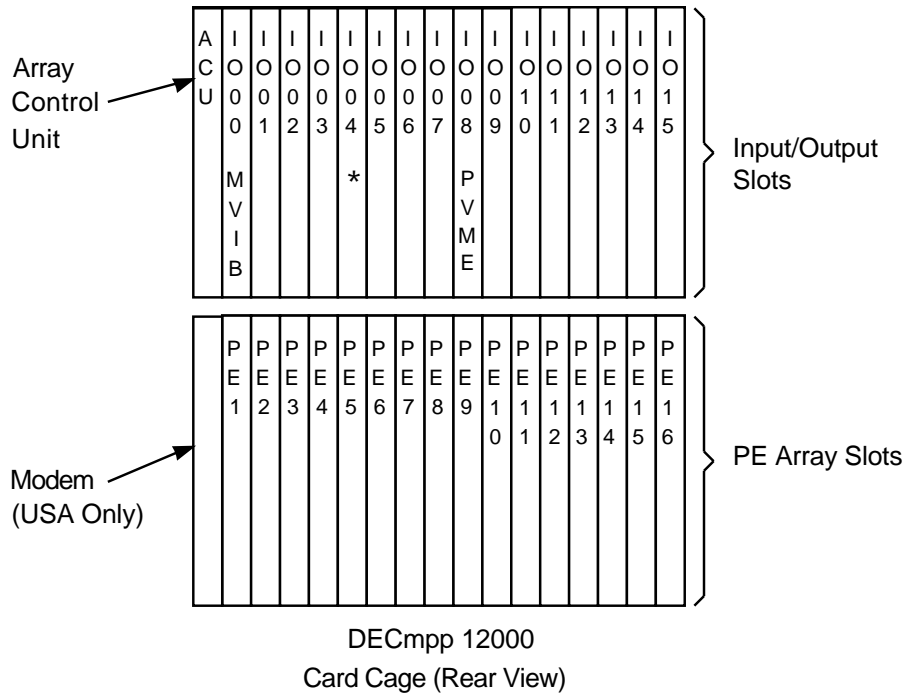

\* Slot IO04 Reserved for Optional PDA Interface

MKV-040000314-03-RAGS

## 3.4 Data Parallel Unit Installation

### 3.4.3.2 Installing the PCBs

Follow these steps to install the DPU PCBs:

---

#### Caution

---

Observe anti-static precautions. ICs may be damaged if anti-static straps are not worn.

---

1. Open the DPU rear door.
2. Strap on the anti-static device (wrist or ankle strap).
3. Remove the upper and lower PCB retainer bars (horizontal bars across PCB face plates). The DECmpp 12000–LC/Sx DPU has only one bar.
4. Before installing the ACU PCB:
  - a. Verify the jumper configuration on the ACU PCB, discussed in Section 3.4.2.1.
  - b. Make sure the ACU crystal oscillator is firmly seated on the PCB as shown in Figure 3–12.
5. The ACU PCB goes in the leftmost slot in the DPU card cage. The Front-end VME interface PCB (MVIB) goes into slot IO00 (the slot next to the ACU PCB). This assembly is actually two PCBs, the T6000 VMEbus controller PCB mounted on a Parallel VME 6U Adapter PCB. All PE array PCBs are installed from left to right. The balance of the PE array slots (not filled with PE array PCBs) must be occupied by router PCBs.

---

#### Caution

---

Although you might have to push firmly to seat a PCB, avoid forcing PCBs when installing them.

---

6. Replace the upper and lower PCB retainer bars.

### 3.4.4 Data Parallel Unit Backplane Jumpers

Jumpers are installed on the DPU backplane for both the I/O and the PE array slots. As MPVMEbus I/O devices are added and removed, corresponding jumpers above each I/O slot must be added and removed. The X-Net jumpers are factory-set for your PE array configuration as shipped. When upgrading to a larger PE array configuration, refer to the *DECmpp 12000/Sx Hardware Service Manual* for upgrade procedures and locations of the PE array X-Net jumpers.

Refer to Figure 3–15 and Figure 3–16. Each I/O slot, IO01 through IO14, has a set of pins above it which allow certain MPVMEbus signals to be jumpered past those slots that are not occupied by PCBs. Going from right to left, ensure that the set of three jumpers have been removed from above all IO01 through IO14 slots that are occupied by MPVMEbus PCBs.

Conversely, ensure that jumpers are installed above *all unoccupied* I/O slots up to, but not including, the slot containing the last I/O PCB. Slots after (to the left of) the last occupied I/O slot may or may not have the jumpers installed. It is of no consequence.

### 3.4 Data Parallel Unit Installation

Figure 3-15 Data Parallel Unit Backplane Jumper Locations

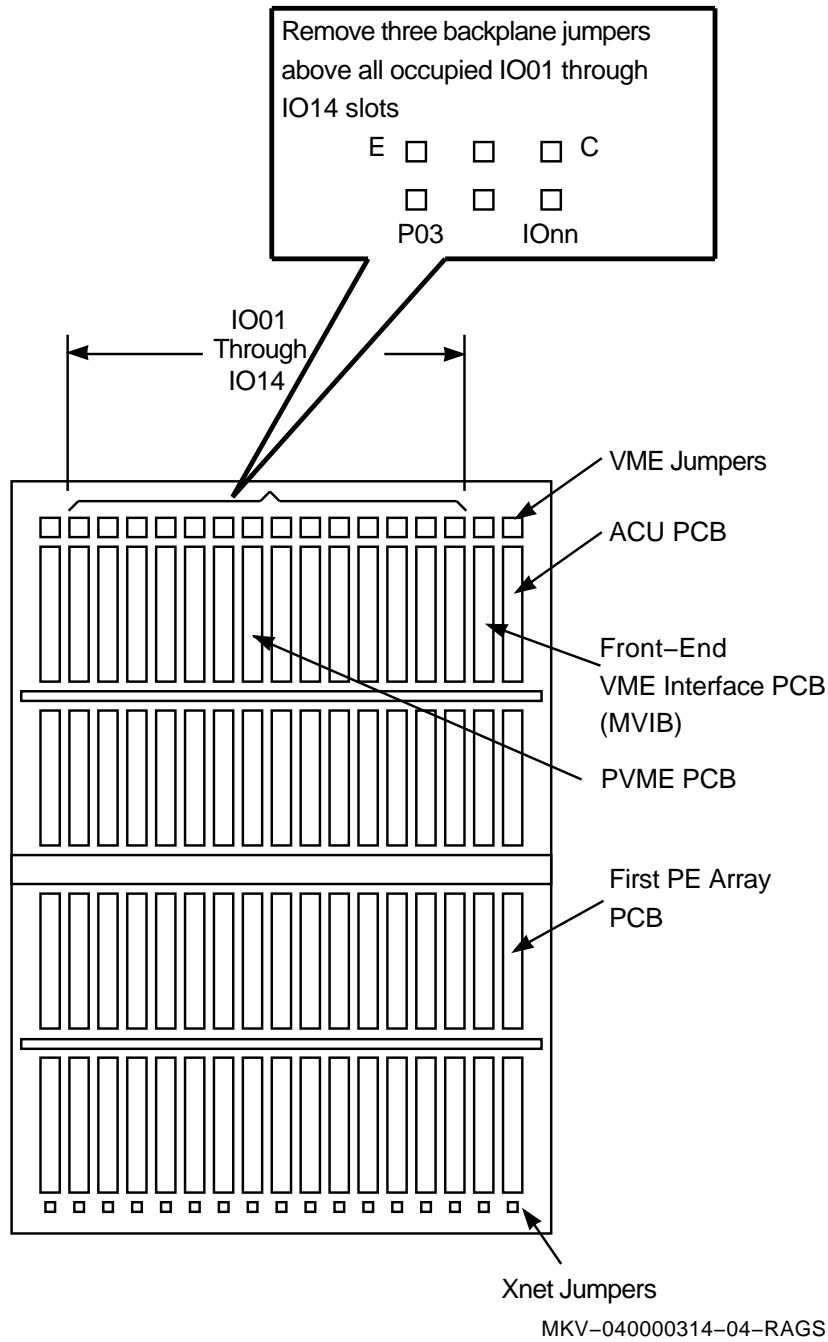

### 3.4 Data Parallel Unit Installation

Referring to Figure 3–16, ensure that backplane jumpers are installed above the ACU and IO00 (MVIB) slots as shown.

Refer to the *DECmpp 12000/Sx Hardware Service Manual*, Section 7.1.3, for a complete listing of all DPU backplane jumpers, including Xnet jumpers.

**Figure 3–16 ACU/MPVMEbus Backplane Jumpers**

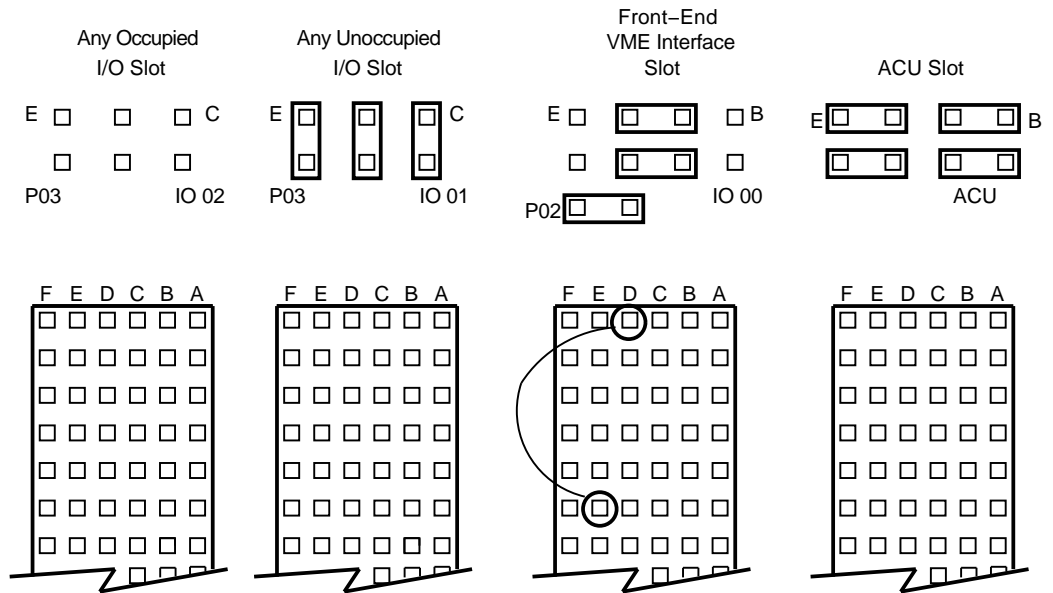

MKV-04000314-21-RAGS

### 3.4 Data Parallel Unit Installation

#### 3.4.5 Connecting the Data Parallel Unit and DECstation Cables

This section provides procedures for connecting the DPU and server cables. Figure 3-17 provides a simplified diagram of the DPU-server cabling.

**Caution**

Inspect all cable connectors to make sure all the pins are straight. If any pin is bent, do not try to install the cable; procure a replacement cable.

**Figure 3-17 DPU-Server Cables**

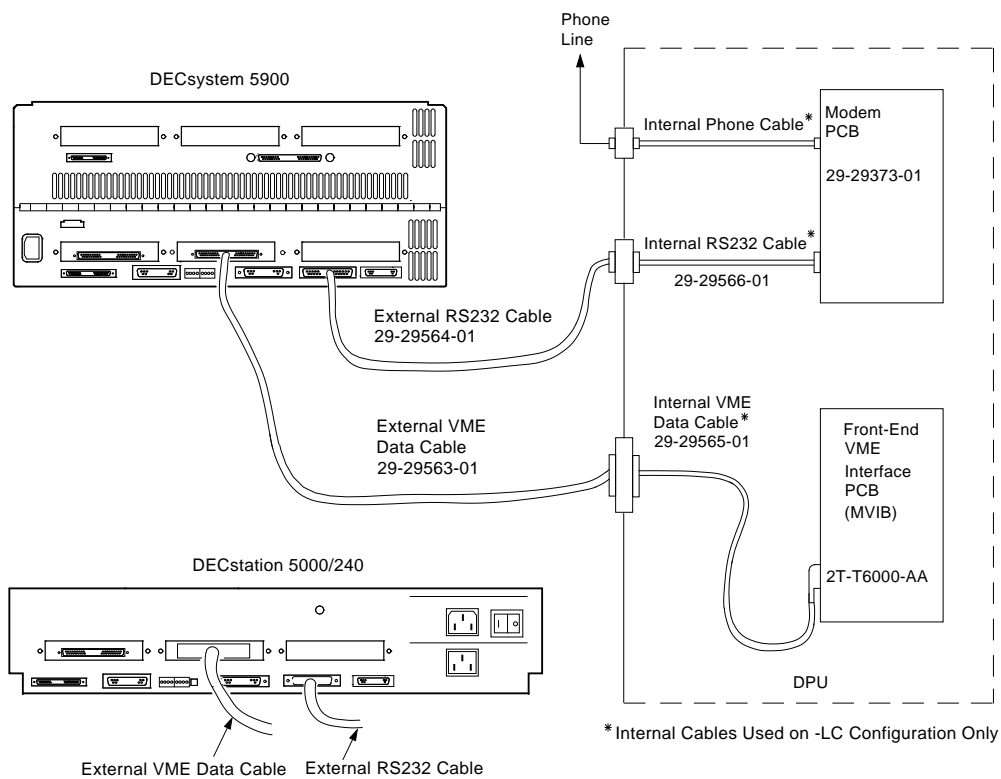

MKV-040000314-40-DG

## 3.4 Data Parallel Unit Installation

### 3.4.5.1 Connecting the Internal DPU Cables (DECmpp 12000–LC only)

After installing the DPU PCBs, follow these steps to connect the internal DPU cables. This procedure applies to the DECMpp 12000–LC only. The DECMpp 12000 configuration (H9A00 series cabinet) does not use these internal cables.

1. Connect the 100-pin AMP connector (labeled J3) of the 4-foot internal data cable (PN 17-03007-01) to the 100-pin connector on the Front-end VME interface PCB (MVIB). This is the T6000 PCB mounted on a Parallel VME 6U Adapter PCB located in DPU backplane, slot IO00.
2. Connect the AMP connector at the cable's opposite end (labeled JB) to the DPU bulkhead interface PCB connector labeled P0B. This connector is located behind the rear cable panel.
3. Connect one end of the 2-foot internal telephone cable to the modem connection in the DPU.
4. Connect the other end of the internal telephone cable to the DPU interface PCB behind the rear cable panel.

### 3.4.5.2 Connecting the External DPU Cables

Two cables connect the DPU and the server.

1. Connect the external data cable.

#### **DECmpp 12000/Sx configuration**

Connect the 100-pin AMP connector (labeled A1) of the 15-foot external data cable to the 100-pin connector on the Front-end VME interface PCB (MVIB). This is the T6000 PCB mounted on a Parallel VME 6U Adapter PCB located in DPU backplane slot I/O00.

#### **DECmpp 12000–LC/Sx configuration**

Connect the 100-pin AMP connector (labeled A1) of the 15-foot external data cable to the other end of the 100-pin connector on the DPU bulkhead interface PCB.

2. Connect the 100-pin AMP connector (labeled P1) of the external data cable to the 100-pin connector on the back of the server.

For the DECsystem 5900, this is connector ③ in Figure 3–18.

For the DECstation 5000, this is connector ③ in Figure 3–19.

3. Connect the external RS-232 cable.

#### **DECmpp 12000 configuration**

Connect one end of the 15-foot external RS-232 cable to the 25-pin connector on the modem cable plate in the DPU card cage.

#### **DECmpp 12000–LC configuration**

Connect one end of the 15-foot external RS-232 cable to the 25-pin connector on the DPU bulkhead interface PCB.

4. Connect the other end of the external RS-232 cable to the 25-pin connector on the back of the server.

For the DECsystem 5900, this is connector ④ in Figure 3–18.

For the DECstation 5000, this is connector ④ in Figure 3–19.

### 3.4 Data Parallel Unit Installation

Figure 3–18 DECsystem 5900 CPU Rear Panel Connectors

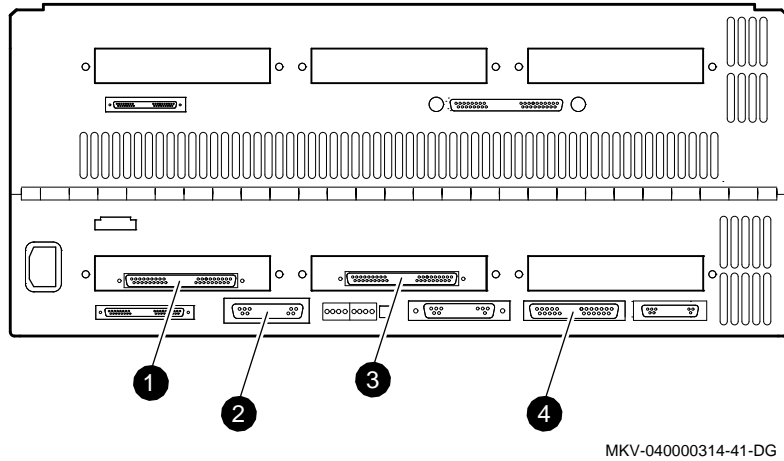
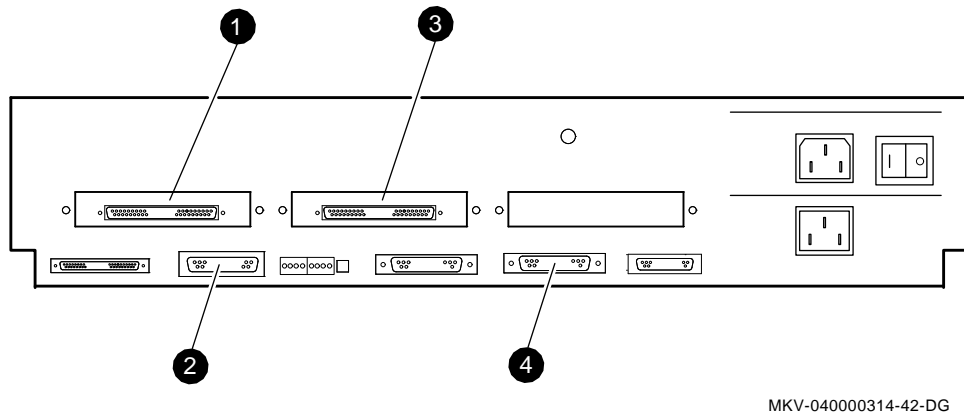

Figure 3–19 DECstation 5000 Rear Panel Connectors



#### 3.4.6 Preparing the System Modem

An X11 telephone jack on the DPU cable panel connects a 2500-style (normal analog) telephone circuit to the modem inside the DPU. This modem is used to access the DECmpp 12000 system when providing customer support remotely.

Systems shipped inside the United States are equipped with internal modems. In DECmpp 12000–LC systems the modem cables are already installed, going from the interface panel to the modem.

Systems shipped outside the United States are equipped with connections for external modems. Modems can be purchased locally and installed by Digital personnel.

The modem requires software configuration in order to work correctly. Instructions are provided in the *DECmpp 12000/Sx System Administration Guide*.

### 3.4.7 Connecting the DPU Power Cable

---

#### Warning

---

Turning on power before you are instructed to do so can cause personal injury or damage to equipment.

---

---

#### Caution

---

The DPU and the server each require *dedicated* power circuits. They cannot share a power circuit with any other device, including each other.

---

#### **For DECmpp 12000/Sx system configurations:**

The DECmpp 12000/Sx DPU requires a *dedicated* 30 A, 220 Vac single phase circuit. In the United States, use a 30 A, 250 V connector such as Hubble #231A.

The DECsystem 5900 server requires a *dedicated* 20 A, 220 Vac single phase circuit. In the United States, use a 310 A, 250 V connector such as Hubble #231A.

The DECstation 5000 requires either a *dedicated* 15 A, 110 V circuit, or a *dedicated* 10 A, 220 V single phase circuit, depending on destination country.

DECmpp 12000/Sx systems shipped in the United States are equipped with a dedicated 30 A, 250 V connector. DECmpp 12000 systems shipped outside the United States are equipped with the same connector, however, depending on local codes, you can choose to do one of the following:

- Connect the DPU power cable to a local adapter.
- Replace the DPU power cable and connector with a local power cable and connector with a power handling rating equal to, or greater than, the original.

Appendix B provides the instructions for replacing the power cable for the DECmpp 12000/Sx DPU. The DECmpp 12000-LC system does not normally require this procedure.

---

#### Warning

---

To avoid personal injury or damage to the equipment, read the instructions in Appendix B carefully. Have all connections inspected by a qualified electrician who is familiar with local codes.

---

#### **For DECmpp 12000-LC/Sx system configurations:**

The DECmpp 12000-LC/Sx DPU requires either a *dedicated* 15 A, 110 V circuit or a *dedicated* 10 A, 220 V single phase circuit, depending on destination country.

The DECstation 5000 requires either a *dedicated* 15 A, 110 V circuit, or a *dedicated* 10 A, 220 V single phase circuit, depending on destination country.

## 3.4 Data Parallel Unit Installation

110 Vac DECmpp 12000–LC/Sx systems are equipped with a standard NEMA L5-15 connector attached to the power cable. 220 Vac DECmpp 12000–LC/Sx systems are equipped with a standard NEMA L6-20P connector attached to the power cable.

Connect one end of the cable to the DECmpp 12000–LC and the other to the power source. The proper power source is one of the following, depending on country of destination:

- A *dedicated* 110 Vac, 15A circuit
- A *dedicated* 220 Vac, 10A single phase circuit

## 3.5 DPU Controls and Indicators

The DPU has several controls, at both the front and rear of the enclosure. The following sections describe the DPU controls and the various status indicators. Figure 3–20 shows the front controls. Figure 3–21 shows the rear controls.

### 3.5.1 Front Controls and Indicator

To access the front controls in the DECmpp 12000 configuration, open the front door. The front controls are located inside, near the top of the enclosure.

To access the front controls in the DECmpp 12000–LC configuration, open the front door. The front controls are located at the top outer surface of the inner front door.

Figure 3–20 Data Parallel Unit Front Controls

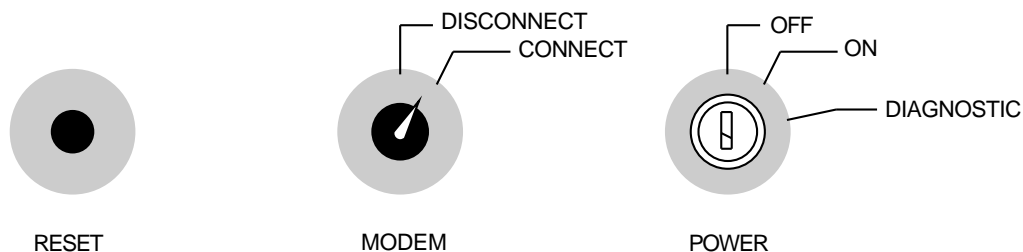

MKV–040000314–43–RAGS

- **POWER** keyswitch—The POWER keyswitch has three settings:
  - OFF (straight up) turns DPU power off.
  - ON (middle position) turns DPU power on when the power selector switch is set to LOCAL.
  - DIAGNOSTIC (lower position) is similar to ON, but also enables the VMEbus RESET button.
- **MODEM** switch—The MODEM switch has two settings:
  - CONNECT enables the internal DPU system modem and allows remote support access.
  - DISCONNECT disables the modem.
- **RESET** pushbutton—Resets the VMEbus if the keyswitch is set to DIAGNOSTIC.

## 3.5 DPU Controls and Indicators

- **POWER** indicator—Located at the top left front of the DPU enclosure, POWER indicates the condition of the power supply. It is amber during the power up sequence, and green when the DPU has powered up correctly.  
When you first turn on the DPU, this indicator is amber for approximately 3 seconds, then it changes to green. Any other behavior indicates a malfunction.

### 3.5.2 Rear Controls and Indicators

Rear controls and indicators are accessed from the rear of the DPU enclosure by opening the rear door (Figure 3–21).

Figure 3–21 Data Parallel Unit Rear Controls and Indicators

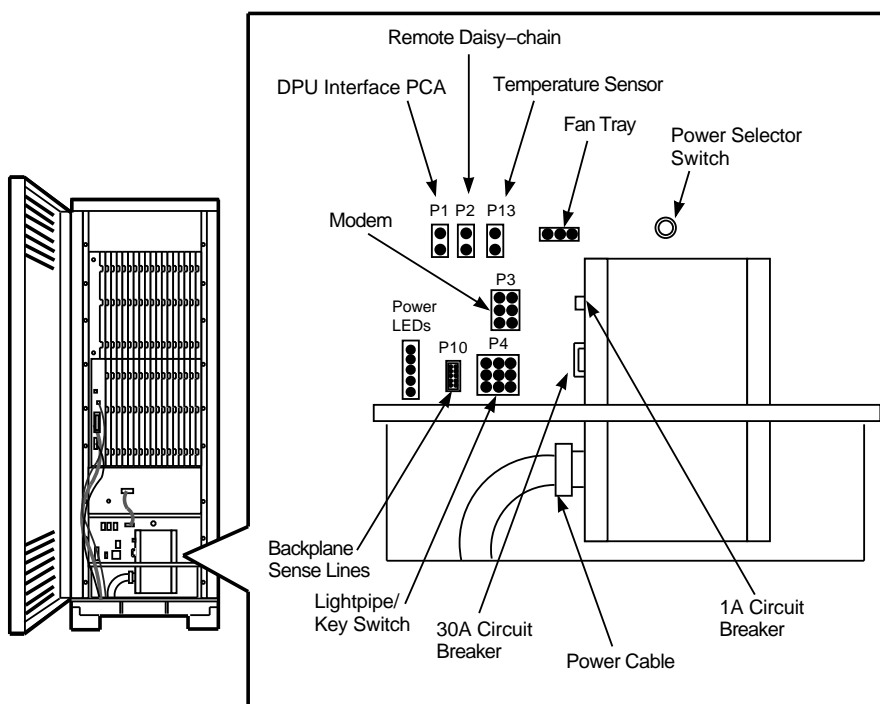

MKV-04000314-81-RAGS

- **POWER SELECTOR** switch—The POWER selector switch is on the power tray rear panel (inside the DPU enclosure at the lower rear), above the rectangular extension connecting the power tray to the DPU lower-rear panel. It is a *toggle switch that must be pulled out slightly* before it can be moved. The POWER selector switch has three positions:
  - LOCAL (middle position): Turns on the DPU independent of the server.
  - OVERRIDE (straight up): Turns on the DPU, regardless of other conditions.

## 3.5 DPU Controls and Indicators

- REMOTE (lower position): Not used.

---

### Warning

---

OVERRIDE is for factory use only. Do not use this setting. It overrides critical safety systems.

---

- Two circuit breakers are at the rear of the DPU.  
The rocker switch next to the power cable is a 30A breaker that is ON when it is UP. The amber lamp above the rocker switch indicates that there is power on both sides of the 30A breaker.  
The small rocker type breaker controls the current to the circuits controlling the power sequencer. The breaker trips when it detects loads of more than 1 A and pops out. To reset it, push it back in.
- The powerup sequencer turns on the –5 V power supply when the DPU is powered on and verifies its correct operation before turning on the +5 V power supply. It also checks the +12 and –12 V power supplies.  
During this period (approximately 3 seconds), the power indicator is amber. When the sequencer turns on the +5 V power supply, the power indicator turns green.  
If the power indicator remains amber, the power-up sequencer did not complete its sequence successfully, indicating there is a problem. You should contact Digital Services for assistance.

## 3.6 Powering Up the DPU for the First Time

---

### Caution

---

When initially installing the DPU, a check of all power supply voltage levels must be made. This can prevent installation problems.

---

1. Open the front and back doors of the DPU.
2. Before proceeding, remove each PCB from the backplane in both the upper and lower card cages. While wearing an anti-static strap, unplug all PCBs from the backplane one inch and allow them to rest in the card cage.
3. Completely remove and replace all blank filler panels. This insures that they are seated properly in their tracks. Filler panels are installed in place of PCBs to aid in proper cooling air flow.
4. Ensure that there are no shorts in the DC voltage supply system. With an ohmmeter, check the +5V, -5V, +12V, and -12V connections at the DPU backplane with respect to ground. Figure 3–22 shows the test points. A zero ohm reading indicates a short and must be investigated before applying power.

## 3.6 Powering Up the DPU for the First Time

Figure 3–22 DPU Backplane Voltage Test Points

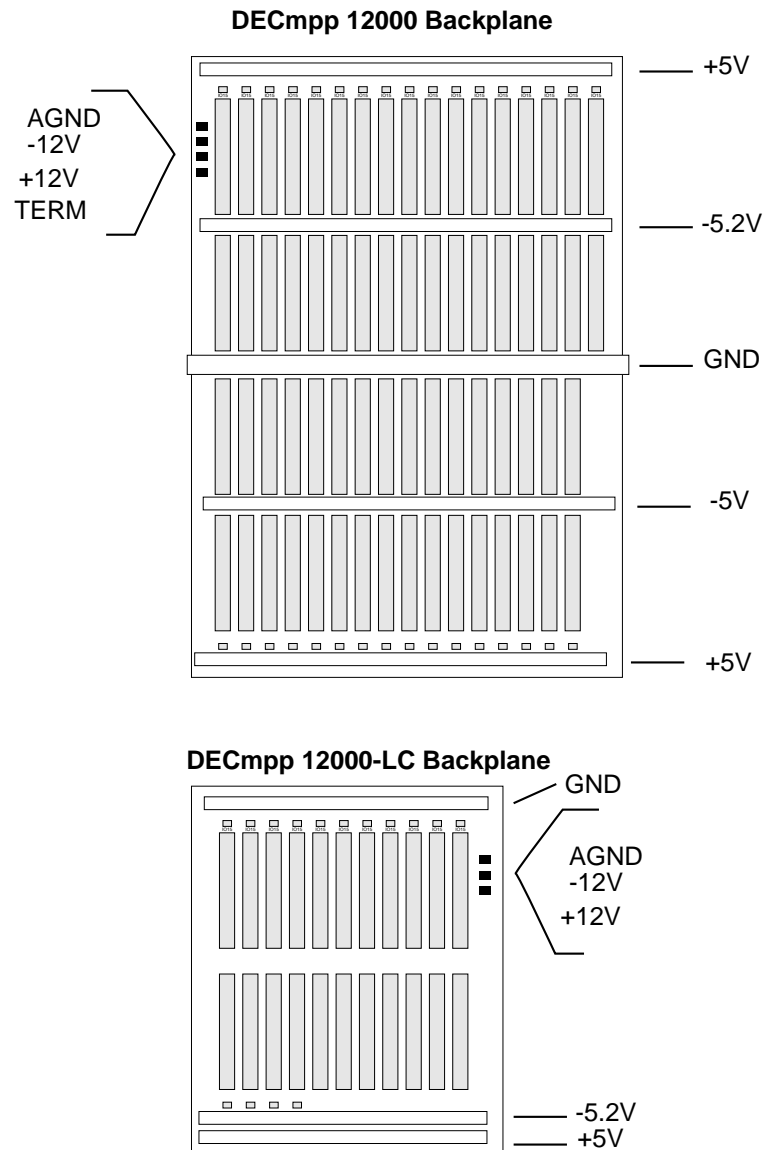

5. Plug the power cable into the source of power.
6. Turn the 30 A circuit breaker ON.
7. Set the power selector switch to LOCAL.
8. Turn power on to the DPU with the keyswitch.
9. Ensure that the front POWER indicator goes from off to yellow, then finally to green.
10. The data parallel unit (DPU) has four power supply voltage output levels: +5 V, -5.2 V, +12 V, and -12 V. Measure these voltages at the DPU backplane, at the test points shown in Figure 3–22 with a digital voltmeter.

### 3.6 Powering Up the DPU for the First Time

For DECmpp 12000/Sx systems adjust the voltage levels at the points shown in Figure 3–23.

For DECmpp 12000–LC systems adjust the voltage levels at the points shown in either Figure 3–24 or Figure 3–25, depending on the power supply used in the system.

---

#### Warning

---

Physical tolerances are very tight at the power supply. 5 V current levels are in the 600 A range.

**Do not short the power supply leads to ground or to other power supply leads.**

**Do not use conductive adjustment tools. Use only insulated tools.**

**When working around the power supply, do not wear loose clothing or jewelry, especially watches or rings.**

Failure to observe these precautions can cause personal injury or damage to the equipment.

---

Figure 3–23 DECmpp 12000 Power Supply Voltage Adjustments

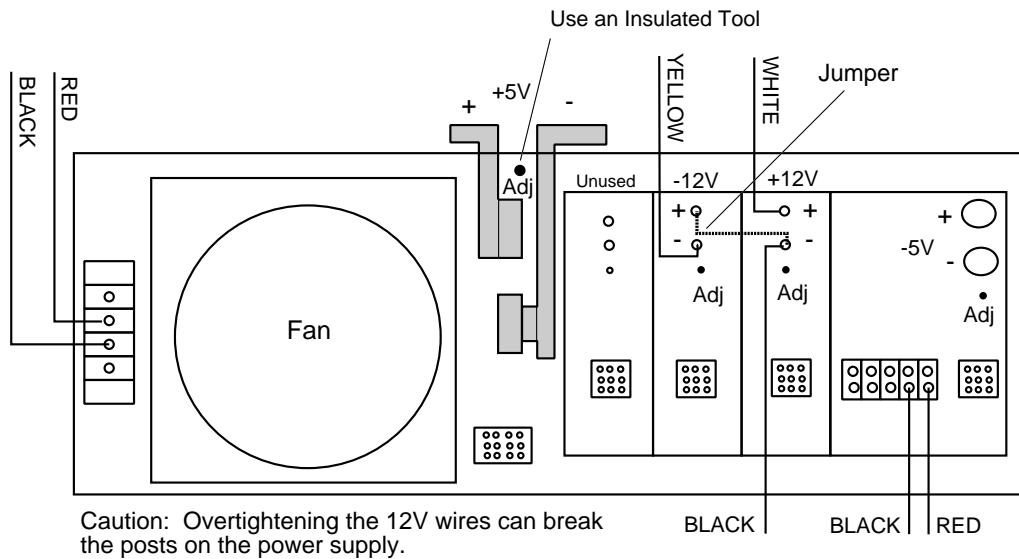

MKV-040000314-58-MPS

### 3.6 Powering Up the DPU for the First Time

Figure 3–24 DECmpp 12000-LC/Sx HC Power Supply and Voltage Adjustments

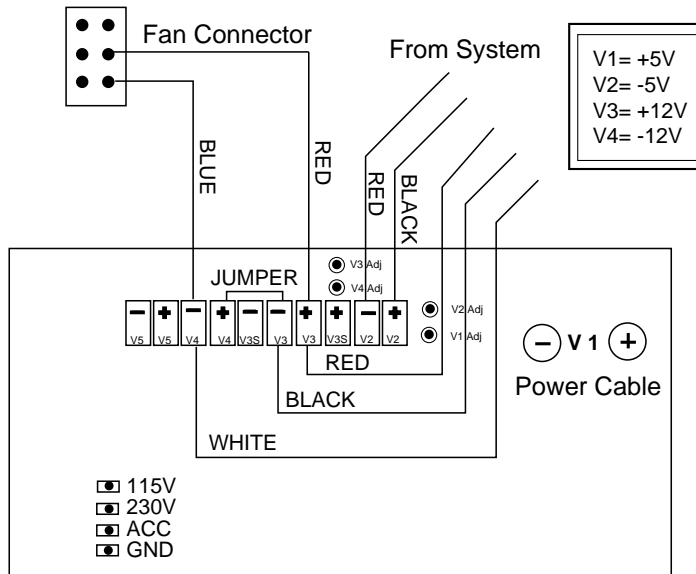
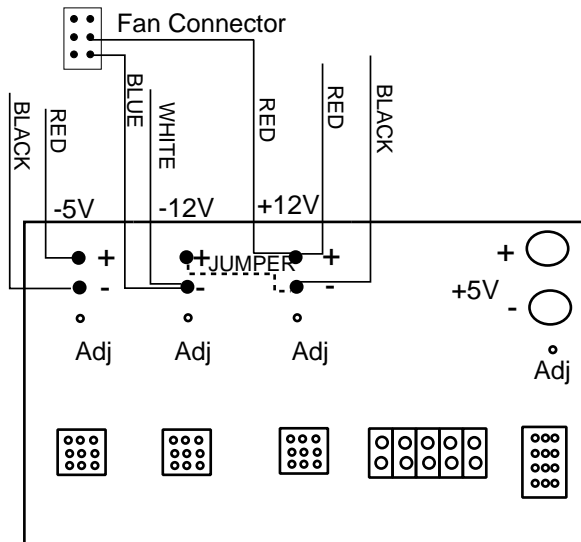

Figure 3–25 DECmpp 12000-LC/Sx Powertec Power Supply and Voltage Adjustments



Caution: Overtightening the 12V wires can break the posts on the power supply.

## 3.6 Powering Up the DPU for the First Time

---

### Note

---

Adjust voltages *only* if they measure outside the tolerances specified in the following lists.

---

- +5 V Supply
    - Adjust only if it is outside the range of +4.95 to +5.05 V.
    - Adjust to exactly 5.0 V.
  - –5.2 V Supply
    - Adjust only if it is outside the range of –5.25 to –5.15 V.
    - Adjust to exactly –5.2 V.
  - –12 V Supply
    - Adjust only if it is outside the range of –12.15 to –11.85 V.
    - Adjust to exactly –12 V.
  - +12 V Supply
    - Adjust only if it is outside the range of +12.15 to +11.85 V.
    - Adjust to exactly +12 V.
11. Turn off power to the DPU.
  12. Reinstall and secure all card cage PCBs using the ejector levers, seating them firmly into the backplane.
  13. Turn DPU power on.
  14. Remeasure the DC voltages and fine tune them if necessary.
  15. Close the front and rear doors.
  16. Power on the server.

## 3.6 Powering Up the DPU for the First Time

17. Boot the server.

18. At the system prompt, enter boot. For example:

```
> boot
```

The system prompts you for a password for root and system accounts.

An example of the startup messages that may appear on the console follows. This example is an approximation and may not be the precise dialog you observe. Individual system configurations dictate differences in device parameters.

```
----- EVENT INFORMATION -----  
  
EVENT CLASS                                OPERATIONAL EVENT  
OS EVENT TYPE                               300.    SYSTEM STARTUP  
SEQUENCE NUMBER                             0.  
OPERATING SYSTEM                           ULTRIX 32  
OCCURRED/LOGGED ON                          Tue Aug 11 08:07:13 1992 EDT  
OCCURRED ON SYSTEM                          mpdemo.mps.m  
SYSTEM ID                                   x82020230  HW REV: x30  
                                              FW REV: x2  
                                              CPU TYPE: R2000A/R3000  
PROCESSOR TYPE                              KN02/R3000  
MESSAGE                                     ULTRIX V4.2A (Rev. 47 MPSG) System #5:  
_Tue May 12 13:33:00 EDT 1992  
real mem = 92274688  
avail mem = 79495168  
using 1228 buffers containing 9224192  
_bytes of memory  
KN02 processor - system rev 48  
cpu0 ( version 3.0, implementation 2 )  
fpu0 ( version 3.0, implementation 3 )  
asc0 at ibus5  
rz0 at asc0 slave 0 (RZ56)  
rz1 at asc0 slave 1 (RZ57)  
rz4 at asc0 slave 4 (RRD42)  
tz5 at asc0 slave 5 (TK50)  
ln0 at ibus6  
ln0: DEC LANCE Ethernet Interface,  
_hardware address: 08:00:2b:1d:31:25  
dc0 at ibus7  
fb0 at ibus0  
fb: Module type PMAG-BA 1024X864  
vba0 at slot 2 (3VIA/MVIB)  
ms0 at vba0 csr 0xfc800000 vmea32d32  
_vec 0xbe priority 1  
da0 at ms0 slave 0  
(DK515-78 - 4 data drives)  
acu0 at vba0 csr 0xfcc00000 vmea32d32  
_vec 0xd0 priority 1  
iqprobe at be889000  
iq0 at vba0 csr 0xdc000000 vmea32d32  
_vec 0xc0 priority 1
```

19. Begin your system administration procedures, as described in *DECmpp 12000 /Sx System Administration Guide*.

After your system administration procedures are done, the system is ready for use. You should also read the *DECmpp 12000/Sx System Overview Manual* to become more familiar with the DECmpp 12000/Sx system.

## 3.6 Powering Up the DPU for the First Time

---

### Caution

---

To avoid damage to the system, always power up or power down the system in the correct sequence.

---

### 3.6.1 Powerup Sequence Summary

1. Turn on the DPU by setting the keyswitch to ON.
2. Turn on the Parallel Disk Array (PDA) if present in your configuration.
3. Turn on the server.
4. Boot the server.

After the system boots, it is ready to operate.

---

### Note

---

If you boot the server before you power up the DPU, you cannot access the DPU. Any time you reconnect or repower the DPU, you must reboot the server.

---

### 3.6.2 Powerdown Sequence Summary

1. Halt the server by performing an orderly ULTRIX shutdown procedure.
2. Turn off the PDA, if present in your configuration.
3. Turn off the DPU by setting the keyswitch to OFF.
4. Turn off the server.

---

## Installation Checklist

This appendix provides a checklist of the basic installation steps. For more detailed instructions, see Chapter 3.

### A.1 Installation Steps

Follow these basic steps to install any of the DECmpp 12000/Sx Series systems.

1. Make sure your site meets the requirements listed in Chapter 2.
2. Install the server, as described in the server's unique documentation (Section 3.2.1, Section 3.2.2, and Section 3.3).
3. Run the server's power-up self test.
4. Install the DPU:
  - a. Make sure the server is powered down (Section 3.3).
  - b. Make sure the DPU keyswitch is OFF and the rear panel circuit breaker is OFF (down) (Section 3.5).
  - c. Install all DPU PCBs (Section 3.4.3.2).
  - d. Verify the DPU backplane I/O jumpers (Section 3.4.4).
  - e. Connect the VMEbus cable to the DPU cable connector panel (Section 3.4.5.2).
  - f. Connect the VMEbus cable to the server rear panel (Section 3.4.5.2).
  - g. Connect the RS-232 cable to the DPU cable connector panel (Section 3.4.5.2).
  - h. Connect the RS-232 cable to the DECstation rear panel (Section 3.4.5.2).
  - i. Connect the external telephone cable to DPU X11 jack (Section 3.4.6).
5. Make sure the DPU power selector switch (inner rear panel) is set to LOCAL (Section 3.5.2).
6. Connect the DPU power cable (Section 3.4.7).
7. Power up the DPU (Section 3.6).
  - a. Turn the rear circuit breaker ON (Section 3.5.2).
  - b. Turn the keyswitch ON (Section 3.5.1).
8. Power up the server (Section 3.3).
9. Boot the server (Section 3.6, Step 17).

You can now proceed with system administration.



---

## Power Cable Wiring and Replacement

Appendix B describes the procedure for replacing the DECmpp 12000/Sx power cable.

### B.1 Power Cable Wires

DECmpp 12000/Sx systems shipped outside of the United States are equipped with a power cable terminated with a NEMA L6-30P connector. To conform to local wiring standards, you may need to do one of the following:

- Connect the DPU power cable to a local adapter.
- Replace the power plug with one that conforms to local codes.
- Replace the DPU power cable and connector with a local power cable and connector with a power handling rating equal to, or greater than, the original.

Table 2–2 lists alternate power cables and connecting plugs required by local country codes.

---

#### Warning

---

To avoid injury and damage to equipment, make sure all equipment is unplugged before working on any power cable. Also, make sure all changes are inspected by a qualified electrician familiar with local codes.

---

#### B.1.1 Wire Ends

When connecting the power cable wire ends to a plug, always connect green to ground, white to neutral, and black to hot (live).

#### B.1.2 Replacing the Power Cable

If necessary, the system power cable can be replaced to conform to local codes. Refer to the following procedure.

---

#### Warning

---

To avoid injury and damage to the equipment, never work on the cable wiring while any part of the system is connected to power.

---

1. Make sure the server, the DPU, and the optional disk array are all powered off.
2. Set the DPU rear panel circuit breaker OFF.
3. Remove the AC plug from the source of power.

## B.1 Power Cable Wires

4. Remove the old cable as follows:
  - a. Remove six screws (four in front and two in rear) that secure the power tray to the frame and lower air plenum.
  - b. Slide the power tray toward the front of the DPU just enough to give yourself enough room to work on the power input box. Do not strain any of the DC power or sense cables.
  - c. Remove the screws that secure the power input box to the rear of the power supply.
  - d. Remove the power cable leads from the ground stud and the terminal block. Loosen the screws that are recessed into the top of the terminal block; this loosens the power leads. Remove the leads from the terminal block but do not retighten the screws yet.
  - e. Loosen the strain relief fitting by turning the locking nut clockwise.
  - f. When the strain relief fitting is loose, feed the cable through the hole and out of the power input box.
5. Feed the new cable in through the strain relief fitting.
6. Connect the power cable ground lead to the ground stud.
7. Connect the hot (live) power cable leads to the connectors of the terminal block you just removed the old wires from as follows.
  - a. Feed the power cable leads into the holes in the right side of the terminal block.
  - b. You are connecting to a 220 Vac circuit with hot and neutral leads. Connect **HOT** to the side of the terminal block with the **RED** corresponding wire on the opposite side. Connect **NEUTRAL** to the side of the terminal block with the **BLACK** corresponding wire on the opposite side. *Do not deviate from these connection instructions.*
  - c. Tighten the screws on top of the terminal block until the power cable leads are fastened securely.

---

**Note**

---

Before you tighten the strain relief fitting, feed a little extra cable into the power input box so there is no strain on the terminal block connections.

---

8. Tighten the strain relief fitting by turning the lock nut.
9. Reattach the power input box to the power tray.
10. Slide the power tray back into place and secure it with the six screws removed earlier.

## DECmpp Variations and Options

The tables in this appendix provide a list of the part numbers for all DECmpp 12000/Sx/Sx Series system configurations and options associated with the DPU. Refer to a corresponding appendix in the *DECmpp 12000/Sx Parallel Disk Array Reference Manual* for disk array options.

- Table C–1 lists all DECmpp 12000/Sx Series Systems and their internal DPU option numbers.
- Table C–2 lists all DECmpp 12000–LC/Sx Series Systems and their internal DPU option numbers.
- Table C–3 lists the DECmpp Processor Element Array Option numbers.
- Table C–4 lists all DECmpp VMEbus interface options.

**Table C–1 DECmpp 12000/Sx Systems**

Part Number	Description
<b>DECmpp 12000/Sx Systems with DECstation 5000/240 Server<sup>1</sup></b>	
MP101-BA	DECmpp Massively Parallel Processor System (Model 1A, 1K PEs, 16MB RAM), PM381-AK, SZ12J-FA, RZ58, RRD42, 120V
MP101-BB	DECmpp Massively Parallel Processor System (Model 1A, 1K PEs, 16MB RAM), PM381-AL, SZ12J-FA, RZ58, RRD42, 240V
MP101-BC <sup>2</sup>	DECmpp Massively Parallel Processor System (Model 1A, 1K PEs, 16MB RAM), PM381-AM, SZ12J-FA, RZ58, RRD42, Southern Hemisphere 240V
MP102-BA	DECmpp Massively Parallel Processor System (Model 1B, 1K PEs, 64MB RAM), PM381-AK, SZ12J-FA, RZ58, RRD42, 120V
MP102-BB	DECmpp Massively Parallel Processor System (Model 1B, 1K PEs, 64MB RAM), PM381-AL, SZ12J-FA, RZ58, RRD42, 240V
MP102-BC <sup>2</sup>	DECmpp Massively Parallel Processor System (Model 1B, 1K PEs, 64MB RAM), PM381-AM, SZ12J-FA, RZ58, RRD42, Southern Hemisphere 240V
<b>DECmpp 12000/Sx Systems with DECsystem 5900 Server</b>	
MP101-CB	DECmpp Massively Parallel Processor System (Model 1A, 1K PEs, 16MB RAM), DU-59BT1-M3, RZ58, RRD42, 240V
MP102-CB	DECmpp Massively Parallel Processor System (Model 1B, 1K PEs, 64MB RAM), DU-59BT1-M3, RZ58, RRD42, 240V

<sup>1</sup>The data parallel unit in all the models requires 220V 50/60 HZ power source. The voltages indicated in the above descriptions are for the ULTRIX server only.

<sup>2</sup>MP10X-AC models include monitors for use in the Southern Hemisphere.

(continued on next page)

**Table C-1 (Cont.) DECmpp 12000/Sx Systems**

<b>Part Number</b>	<b>Description</b>
<b>DECmpp 12000/Sx Systems with DECsystem 5900 Server</b>	
MP103-CB	DECmpp Massively Parallel Processor System (Model 4A, 4K PEs, 64MB RAM), DU-59BT1-M3, RZ58, RRD42, 240V
MP104-CB	DECmpp Massively Parallel Processor System (Model 4B, 4K PEs, 256MB RAM), DU-59BT1-M3, RZ58, RRD42, 240V
MP105-CB	DECmpp Massively Parallel Processor System (Model 8A, 8K PEs, 128MB RAM), DU-59BT1-M3, RZ58, RRD42, 240V
MP106-CB	DECmpp Massively Parallel Processor System (Model 8B, 8K PEs, 512MB RAM), DU-59BT1-M3, RZ58, RRD42, 240V
MP107-CB	DECmpp Massively Parallel Processor System (Model 16A, 16K PEs, 256MB RAM), DU-59BT1-M3, RZ58, RRD42, 240V
MP108-CB	DECmpp Massively Parallel Processor System (Model 16B, 16K PEs, 1GB RAM), DU-59BT1-M3, RZ58, RRD42, 240V
<b>Internal DPU Components<sup>3</sup></b>	
MPD11-AA	DECmpp 1K Processor Element Data Parallel Unit w/16MB ECC RAM used on MP101-Cx, MP103-Cx, MP105-Cx, MP107-Cx
MPD12-AA	DECmpp 1K Processor Element Data Parallel Unit w/64MB ECC RAM used on MP102-Cx, MP104-Cx, MP106-Cx, MP108-Cx
<sup>3</sup> Internal DPU subassemblies are not field orderable.	

**Table C–2 DECmpp 12000-LC/Sx Series Systems**

Part Number	Description
MP001-BA	DECmpp Massively Parallel Processor System (Model 1A, 1K PEs, 16MB RAM), PM381-AK, SZ12J-FA, RZ58, RRD42, 120V
MP001-BB	DECmpp Massively Parallel Processor System (Model 1A, 1K PEs, 16MB RAM), PM381-AL, SZ12J-FA, RZ58, RRD42, 240V
MP001-BC	DECmpp Massively Parallel Processor System (Model 1A, 1K PEs, 16MB RAM), PM381-AM, SZ12J-FA, RZ58, RRD42, Southern Hemisphere, 220V <sup>1</sup>
MP002-BA	DECmpp Massively Parallel Processor System (Model 1B, 1K PEs, 64MB RAM), PM381-AK, SZ12J-FA, RZ58, RRD42, 120V
MP002-BB	DECmpp Massively Parallel Processor System (Model 1B, 1K PEs, 64MB RAM), PM381-AL, SZ12J-FA, RZ58, RRD42, 240V
MP002-BC	DECmpp Massively Parallel Processor System (Model 1B, 1K PEs, 64MB RAM), PM381-AM, SZ12J-FA, RZ58, RRD42, Southern Hemisphere, 220V <sup>1</sup>

**Internal DPU Components<sup>2</sup>**

MPD01-AA	DECmpp 1K Processor Element Data Parallel Unit w/16MB ECC RAM, 110V, used on MP001-BA
MPD01-AB	DECmpp 1K Processor Element Data Parallel Unit w/16MB ECC RAM, 220V, used on MP001-BB/BC
MPD02-AA	DECmpp 1K Processor Element Data Parallel Unit W/64MB ECC RAM, 110V, used on MP002-BA
MPD02-AB	DECmpp 1K Processor Element Data Parallel Unit W/64MB ECC RAM, 220V, used on MP002-BB/BC

<sup>1</sup>MP00X-BC models include monitors for use in the Southern Hemisphere.

<sup>2</sup>Internal DPU subassemblies are not field orderable.

The DECmpp 12000-LC/Sx uses the DECstation 5000/240 plus 16MB RAM, VME Adapter and SZ12J Sidecar with RZ58 hard disk and RRD42 CDROM as an ULTRIX server.

**Table C–3 DECmpp 12000 Processor Element Array Options**

Part Number	Description
KP100-AA	DECmpp 1K Processor Element CPU PCB w/16MB ECC RAM
KP100-AB	DECmpp 1K Processor Element CPU PCB w/64MB ECC RAM
KP100-AC	DECmpp 1K Processor Element CPU PCB Upgrade from 16MB ECC RAM to 64MB ECC RAM

**Table C–4 DECmpp MPVMEbus Options**

Part Number	Description
KF100-AA	DECmpp MPVMEbus I/O Controller w/8MB ECC RAM



## A

---

- Accessing the card cage, 3-15
- ACU crystal oscillator, 3-19
- ACU slot, 3-16
- Array control unit, 1-1
  - installing, 3-19
  - jumpers, 3-15
  - VMEbus address, 3-15
  - VMEbus interrupt level, 3-15

## C

---

- Card cage, accessing, 3-15
- Circuit breakers, 3-28
- Connecting power cable, 3-25
- Controls
  - circuit breakers, 3-28
  - front, 3-26
  - keyswitch, 3-26
  - MODEM, 3-26
  - POWER, 3-26
  - rear, 3-27
  - RESET, 3-26
- Cooling
  - DECmpp 12000-LC/Sx system, 2-10
  - DECmpp 12000/Sx system, 2-6
  - PDA, 2-13

## D

---

- Damage to shipping container, 3-3, 3-7
- Data parallel unit, 1-1
  - connecting power cable, 3-25
  - initial powerup, 3-28
  - installation, 3-13
  - jumpers, 3-19
  - keyswitch, 3-26
  - powerup, 3-34
- Data parallel unit (-LC)
  - connecting power cable, 3-25
- DECmpp 12000, processor element array slots, 1-1
- DECmpp 12000-LC/Sx, 1-1
- DECmpp 12000/Sx
  - power cable, B-1
  - wiring, B-1

- DECmpp 12000/Sx enclosure, 1-1
- DECstation 5000
  - cabling, 3-23
  - self-test messages, 3-13
  - unpacking instructions, 3-2
- DECsystem 5900
  - cabling, 3-23
  - self-test messages, 3-12
  - unpacking instructions, 3-2
- DPU power supply levels, 3-28
- DPU unpacking instructions, 3-3, 3-7

## E

---

- Ejector levers, 3-14
- Electrical requirements
  - DECmpp 12000-LC/Sx, 2-9
  - DECmpp 12000/Sx, 2-3
- Ethernet requirements, 2-7, 2-11

## F

---

- Front controls, 3-26
- Front indicator, 3-26
- Front-end VME interface, 3-16

## I

---

- I/O slots, 3-16
  - DECmpp 12000-LC/Sx, 1-1
  - DECmpp 12000/Sx, 1-1
- Indicators
  - front, 3-26
  - POWER, 3-26
  - rear, 3-27
- Installation
  - DECstation 5000, 3-12
  - DECsystem 5900, 3-12
  - DPU, 3-13
- Installing ACU PCB, 3-19
- Installing PCBs, 3-19
- Interrupt level, ACU, 3-15

## J

---

### Jumpers

- array control unit, 3-15
- DPU, 3-19

## K

---

- Keyswitch, 3-26

## M

---

### Modem, 3-24

- connections, 3-24
- requirements, 2-7, 2-11

### MODEM switch, 3-26

### MVIB slot, 3-16

## P

---

### Parallel Disk Array, 2-12

- cooling requirements, 2-13
- power requirements, 2-13
- space requirements, 2-12
- specifications, 2-13

### PE array

- number, 1-1
- size, 1-1
- slots, 3-16

### Power

- DECmpp 12000-LC/Sx system, 2-9
- DECmpp 12000/Sx, 2-3
- PDA, 2-13

### Power Cable

- DECmpp 12000/Sx, B-1

### Power Cable Replacement, B-1

### Power cables, 2-5, 2-10

### POWER indicator, 3-26

### Power plugs, 2-5

### Power requirements, 3-25

### Power selector, 3-27

### Power up sequencer, 3-28

### Powerdown sequence, 3-34

### Powerup sequence, 3-34

### Precautions

- static discharge, 3-14

### Processor element array slots

- DECmpp 12000-LC/Sx, 1-1
- DECmpp 12000/Sx, 1-1

### Processor elements, 1-1

## R

---

### Rear controls, 3-27

### Rear indicators, 3-27

### Replacing Power Cable, B-1

### RESET switch, 3-26

## S

---

### Self-Test messages, 3-12, 3-13

### Shipping container damage, 3-3, 3-7

### Shipping container inspection, 3-7

### Shockwatch indicator, 3-7

### Single-instruction, multiple data, 1-1

### Site preparation, 2-1

- DECmpp 12000-LC/Sx, 2-8

- DECmpp 12000/Sx, 2-2

- DECstation 5000/240, 2-8

- DECsystem 5900, 2-2

### Space requirements

- DECmpp 12000-LC/Sx system, 2-8

- DECmpp 12000/Sx system, 2-2

- PDA, 2-12

### Specifications

- PDA, 2-13

### Static discharge precautions, 3-14

### System power requirements, 3-25

### System powerdown sequence, 3-34

### System powerup sequence, 3-34

## T

---

### 2500 telephone circuit, 3-24

### Telephone connections, 3-24

### Tip-n-Tell Indicator, 3-7

## U

---

### Unpacking instructions

- DECmpp 12000-LC/Sx, 3-7

- DECmpp 12000/Sx, 3-3

- DECstation 5000, 3-2

- DECsystem 5900, 3-2

## V

---

### VMEbus address

- ACU, 3-15

### Voltage measurement, 3-29

## W

---

### Wiring

- DECmpp 12000/Sx, B-1