

DECsystem 5900/260

CPU Card Installation

Order Number: EK-D5960-IN. A01

First Printing, June 1993

The information in this document is subject to change without notice and should not be construed as a commitment by Digital Equipment Corporation.

Digital Equipment Corporation assumes no responsibility for any errors that may appear in this document.

Any software described in this document is furnished under a license and may be used or copied only in accordance with the terms of such license. No responsibility is assumed for the use or reliability of software or equipment that is not supplied by Digital Equipment Corporation or its affiliated companies.

Restricted Rights: Use, duplication, or disclosure by the U.S. Government is subject to restrictions as set forth in subparagraph (c)(1)(ii) of the Rights in Technical Data and Computer Software clause at DFARS 252.227-7013.

© Digital Equipment Corporation 1993.
All Rights Reserved.
Printed in U.S.A.

The following are trademarks of Digital Equipment Corporation: CI, CompacTape, DEC, DECconnect, DECnet, DECserver, DECsystem 5900, DECwindows, RRD40, RRD50, RX, ThinWire, TK, TS, TU, TURBOchannel, ULTRIX, VAX, VAX DOCUMENT, VMS, VT, and the Digital logo.

All other trademarks and registered trademarks are the property of their respective holders.

FCC NOTICE: This equipment has been tested and found to comply with the limits for a Class A digital device, pursuant to Part 15 of the FCC Rules. These limits are designed to provide reasonable protection against harmful interference when the equipment is operated in a commercial environment. This equipment generates, uses, and can radiate radio frequency energy and, if not installed and used in accordance with the instruction manual, may cause harmful interference to radio communications. Operation of this equipment in a residential area is likely to cause harmful interference, in which case users will be required to correct the interference at their own expense.

This document is available in hard copy only.

S2107

This document was prepared using VAX DOCUMENT, Version 2.1.

Contents

Preface	v
1 Overview	
1.1 Removing and Replacing the CPU/Daughter Card	1-2
1.2 Unpacking the Upgrade Shipment	1-3
1.3 Conversion Kit Contents	1-3
2 Removing and Replacing the CPU/Daughter Card	
2.1 Enclosure Door Access	2-2
2.2 Turning Off the System	2-4
2.3 Stabilizing the Enclosure	2-5
2.4 Pulling Out/Pushing In the Drawer	2-6
2.5 CPU Drawer Compartments and Covers	2-9
2.6 Opening and Closing the CPU Drawer Middle Top Cover	2-10
2.7 Removing and Replacing the CPU/Daughter Card	2-13
2.8 Installing the EMI Grounding Material	2-16
2.9 Installing the Conversion Label	2-17
2.10 Completing the Installation	2-18
3 Diagnostics and Testing	
3.1 Acceptance Testing	3-1
3.1.1 Power-Up Self-Test (POST)	3-1
3.1.2 System Configuration Check	3-1
3.1.3 Extended ROM Tests	3-2
3.1.4 SCSI Test Commands	3-4
3.2 Modifying ULTRIX	3-5

A Mandatory Card Return Procedure and Forms

A.1	Return Procedure	A-1
A.2	Return Forms	A-2
A.3	Customer Administrative Services (CAS) District Offices	A-11

Figures

2-1	Opening the Front Enclosure Door	2-2
2-2	Opening the Rear Enclosure Door	2-3
2-3	CPU Drawer Front Panel	2-4
2-4	Power Controller	2-5
2-5	Stabilizing the Enclosure	2-6
2-6	Pulling Out the CPU Drawer	2-7
2-7	Pushing In the CPU Drawer	2-8
2-8	CPU Drawer Compartments and Covers	2-10
2-9	Opening the Middle Top Cover	2-11
2-10	Latching the Middle Top Cover Upright	2-12
2-11	Removing the R3000A CPU/Daughter Card	2-14
2-12	Installing the R4400 CPU/Daughter Card	2-15
2-13	Installing the EMI Grounding Material	2-17
2-14	Conversion Label Location	2-18
2-15	Medallion Location	2-19

Tables

1-1	Conversion Kit Contents for 5900/260	1-3
2-1	CPU Drawer Covers	2-9
3-1	Individual Module/Device Tests	3-2

Preface

Product Description

The R4400 MIPS chip upgrades the DECsystem 5900 system to a DECsystem 5900/260 system. The DECsystem 5900/260 system is a computer system designed for server applications, including file servers, compute-servers, and network servers. It is a midrange system that uses a modular approach, based on industry standard, 47.5 cm (19-inch) rackmount components.

The DECsystem 5900/260 system CPU drawers use a high-performance single-card computer based on the MIPS R4400 processor. The DECsystem 5900 system comes in a single-cabinet configuration that contains a power controller, one or two CPU drawers, and up to four additional mass storage drawers.

Document Description

This manual describes how to remove an R3000 CPU/daughter card from the DECsystem 5900 system and replace it with an R4400 CPU/daughter card. The resulting new system is a DECsystem 5900/260 system. This manual is meant to be used in conjunction with the *DECsystem 5900 Enclosure Maintenance Manual*, EK-D590A-EN.

This manual will be packaged with an upgrade kit to provide step-by-step instructions for Digital Services engineers.

Any service or upgrades needed inside the DECsystem 5900 cabinet must be done by a Digital Services engineer or an authorized self-maintenance customer.

Audience

The *DECsystem 5900/260 Installation Manual* is for use only by Digital Services engineers or authorized self-maintenance customers who are receiving a MIPS R4400 CPU/daughter card upgrade for installation.

Document Structure

The *DECsystem 5900/260 Installation Manual* contains three chapters and an appendix, as follows:

Chapter 1	Overview This chapter is an introduction to the installation procedures.
Chapter 2	Removing and Replacing the CPU/Daughter Card This chapter contains step-by-step procedures to remove the R3000 CPU/daughter card and install the R4400 CPU/daughter card.
Chapter 3	Diagnostics and Testing This chapter contains information needed to run diagnostics and tests.
Appendix A	Mandatory Card Return Procedure and Forms This appendix contains detailed instructions and forms for use in the return of the used card.

Conventions Used in This Document

The *DECsystem 5900/260 Installation Manual* uses the following conventions:

Convention	Indicates
boldface type	User input.
<i>italic type</i>	Important information, variables, and complete titles of manuals.
Note	General information about the current topic.
Caution	Information to prevent damage to equipment or software. Read these carefully.
WARNING	Information to prevent personal injury. Read these carefully.
Return	Press that key.

1

Overview

This manual describes how to remove an R3000 CPU/daughter card from the DECsystem 5900 system and replace it with an R4400 CPU/daughter card. The resulting new system is a DECsystem 5900/260 system. This manual is meant to be used in conjunction with the *DECsystem 5900 Enclosure Maintenance Manual*, EK-D590A-EN.

WARNING

- **Turn off the system power switch and the main circuit breaker to the power controller before installing a CPU/daughter card.**
 - **Extend the stabilizer bar to balance the system whenever one or more drawers are pulled out from the cabinet.**
-

Caution

- Only qualified service personnel should remove or install a CPU/daughter card.
 - Static electricity can damage integrated circuits. Always use a grounded wrist strap and a grounded work surface (29-26246) when working with the internal parts of a computer system.
 - Shut down ULTRIX in an orderly fashion before you install a CPU/daughter card (or any field-replaceable unit) in the DECsystem 5900; procedures in this document assume that ULTRIX has been shut down (see the *Guide to Installing ULTRIX*, AA-PBL0D-TE).
-

1.1 Removing and Replacing the CPU/Daughter Card

The general steps for removing and installing a CPU/daughter card are listed below. They are explained in detail in the referenced sections of this manual.

1. Unpack the upgrade shipment (Section 1.2).
2. Have the customer back up the system software.
3. Shut down ULTRIX in an orderly manner.
4. Open the enclosure doors (Section 2.1).
5. Turn off the system (Section 2.2).
6. Extend the stabilizer bar to balance the system (Section 2.3).
7. Pull out the CPU drawer (Section 2.4).
8. Open the CPU compartment (Section 2.6).
9. Remove the R3000 CPU/daughter card (Section 2.7).
10. Install the R4400 CPU/daughter card (Section 2.7).
11. Install the EMI grounding material (Section 2.8).
12. Attach and fill in the conversion label (Section 2.9).
13. Push in the drawer (Section 2.4).
14. Retract the stabilizer bar (Section 2.3).
15. Turn on the system (Section 2.2).
16. Close the enclosure doors (Section 2.1).
17. Replace the system medallion (Section 2.10).
18. Run acceptance tests (Section 3.1).
19. Modify ULTRIX (Section 3.2).
20. Have the customer reinstall the system backup data.
21. Fill out the forms in Appendix A and return the used CPU/daughter card as instructed.

1.2 Unpacking the Upgrade Shipment

To begin the installation, unpack the R4400 CPU/daughter card upgrade shipment and check to see that it is complete. Section 1.3 lists the conversion kit contents for an R4400 CPU/daughter card upgrade shipment with no additional options or accessories.

1.3 Conversion Kit Contents

Table 1–1 Conversion Kit Contents for 5900/260

Description	Part Number	Quantity
Plas rivet	12-26763-02	2 (N/A)
Wrist strap, static	12-36175-01	1
Warning label	36-19551-01	1 (N/A)
Pack assembly	37-01256-16	1
R4400 CPU card	54-21872-02	1
Standoff removal tool	74-46254-01	1
ULTRIX upgrade license ¹	QL-VYVA8-B5	1
Conversion label	36-15946-XY	1
Medallion	74-44616-03	1

¹The part number of the ULTRIX upgrade license may be different depending upon the version ordered. The part number for the three to eight user upgrade license is shown.

2

Removing and Replacing the CPU/Daughter Card

This chapter describes the removal of an R3000 CPU/daughter card, and replacement with an R4400 CPU/daughter card.

WARNING

- **Turn off the system power before you remove or install field-replaceable units (see Section 2.2).**
 - **Before accessing either the CPU or the mass storage drawers, the stabilizer bar located at the bottom front of the enclosure must be extended to balance the DECsystem 5900 system (see Figure 2-5).**
 - **Do not pull out more than one drawer at a time.**
-

Caution

- Only qualified service personnel should remove or install field-replaceable units (FRUs).
 - Static electricity can damage integrated circuits. Always use a grounded wrist strap and a grounded work surface (29-26246) when working with the internal parts of a computer system.
 - Shut down ULTRIX in an orderly fashion before you remove or install FRUs; the FRU removal and replacement procedures in this document assume that ULTRIX has been shut down first (see the *Guide to Installing ULTRIX*, AA-PBL0D-TE).
-

2.1 Enclosure Door Access

The enclosure doors are opened and closed with a 1/4-inch hex wrench or key (12-26339-01). See Figure 2-1 and Figure 2-2.

Figure 2-1 Opening the Front Enclosure Door

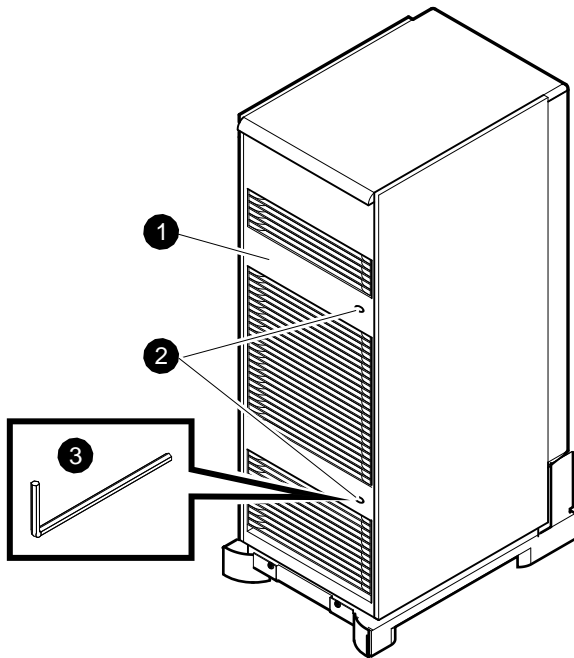

MLO-007705

- ❶ Front door
- ❷ Latches
- ❸ Hex wrench

Figure 2-2 Opening the Rear Enclosure Door

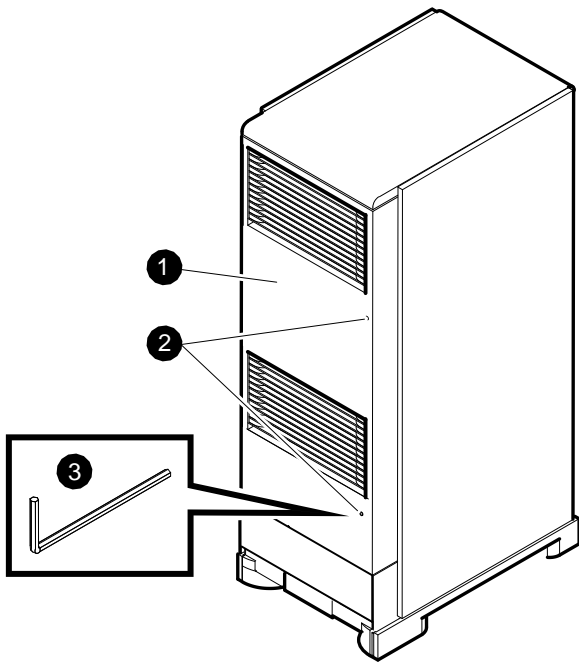

MLO-007744

- ❶ Rear door
- ❷ Latches
- ❸ Hex wrench

2.2 Turning Off the System

Caution

Prior to turning off the DECsystem 5900, ULTRIX must be shut down in an orderly fashion by the customer/system manager.

1. Turn off the system power switch (Enable Power On Switch) on the front of the operational CPU drawer (see Figure 2-3).
2. Turn off the circuit breaker flip switch on the power controller (see Figure 2-4).

The power controller is accessed through the rear door on the bottom of the enclosure.

To turn on the DECsystem 5900/260 system, reverse the above procedures.

Figure 2-3 CPU Drawer Front Panel

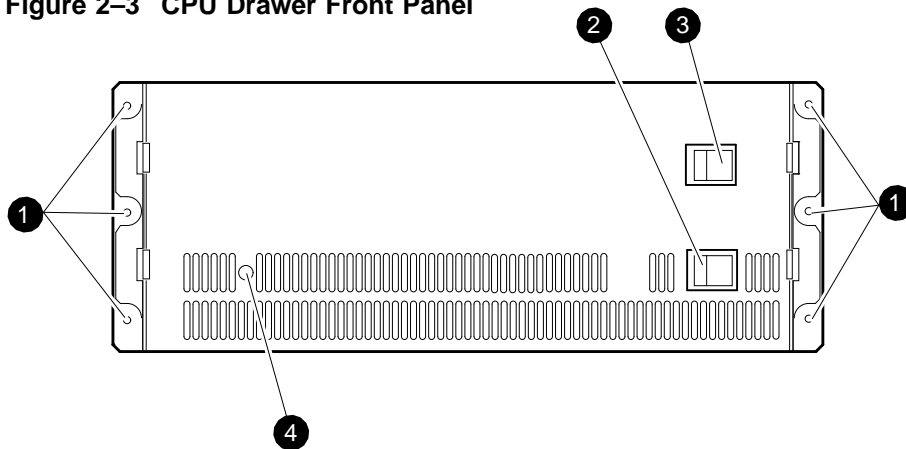

MLO-007651

- 1 5/16-inch hex screws that secure the drawer to the shipping restraint brackets
- 2 CPU drawer power switch (should normally be left on)
- 3 System power switch (Enable Power On Switch)
- 4 LED power indicator

Figure 2-4 Power Controller

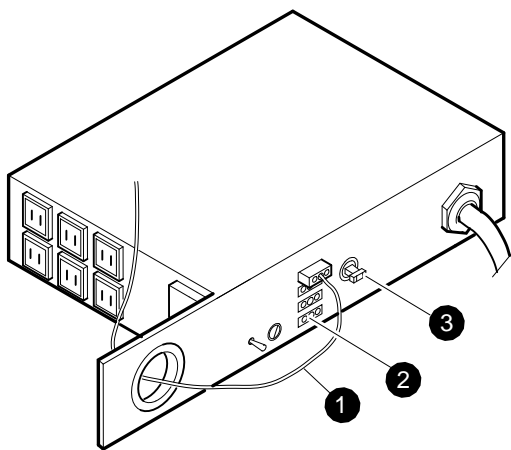

MLO-008353

- ❶ Remote power sequence cable (to CPU drawer)
- ❷ Remote sequence connectors
- ❸ Circuit breaker

2.3 Stabilizing the Enclosure

WARNING

Before accessing either the CPU or the mass storage drawers, the stabilizer bar located at the bottom front of the enclosure must be extended to balance the DECsystem 5900 system (see Figure 2-5).

It is necessary to balance the DECsystem 5900 system before accessing either the CPU or mass storage drawers.

1. Raise the leveler foot if it is tightened down to the floor.
2. Pull the stabilizer bar out until it stops.
3. Screw the leveler foot down firmly by hand.

To retract the arm, reverse these procedures.

Figure 2-5 Stabilizing the Enclosure

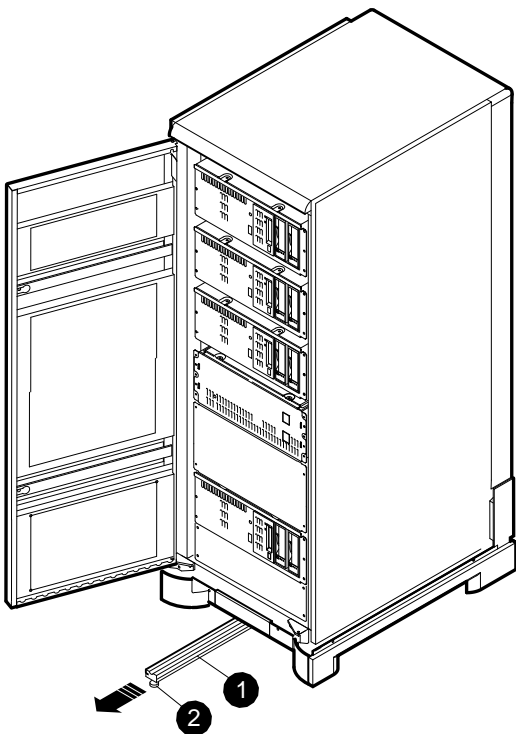

MLO-007752

- ❶ Stabilizer bar
- ❷ Leveler foot

2.4 Pulling Out/Pushing In the Drawer

The CPU drawer is accessed by removing the six hex screws on the front of the drawer with either a screwdriver or a 5/16-inch wrench (see Figure 2-3).

To pull out the CPU drawer, grasp both sides of the drawer's front edge and slide the entire drawer forward from the enclosure until you hear a click. This means that the latches on either of the drawer's slides have sprung out slightly to engage (see Figure 2-6).

Check to see that both latches are engaged; if not, pull the drawer out carefully until the remaining one engages, and the middle cover on the top of the drawer (air plenum compartment, Section 2.5) can be raised and latched in a vertical position.

To push in the CPU drawer after installation, hold the spring tabs in (they should be protruding through the holes) while gently sliding the drawer as depicted in Figure 2-7.

As the CPU drawer is pushed or pulled, the cable arm extends or retracts, keeping the cables organized and out of the way.

Figure 2-6 Pulling Out the CPU Drawer

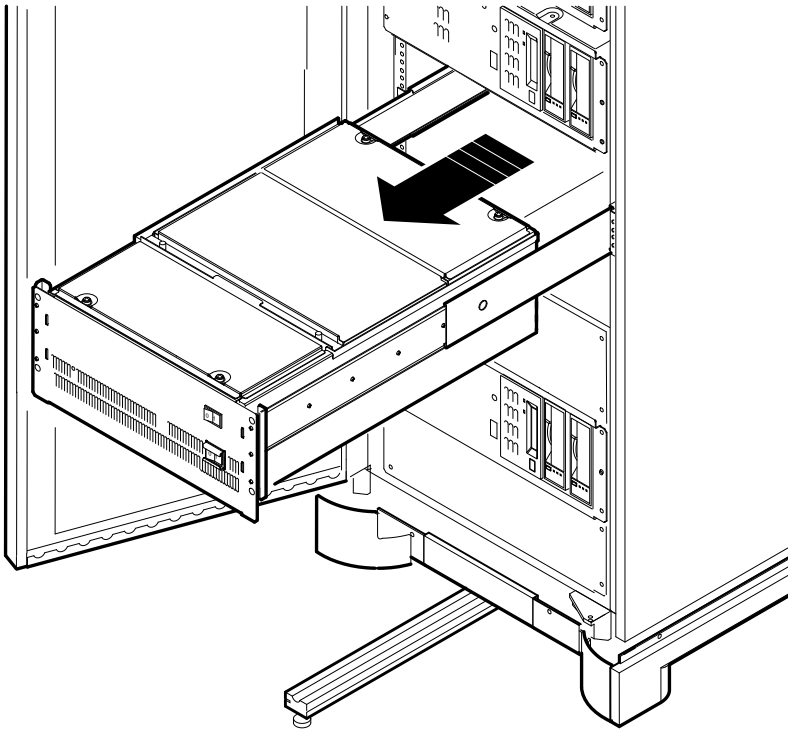

MLO-007753

Figure 2-7 Pushing In the CPU Drawer

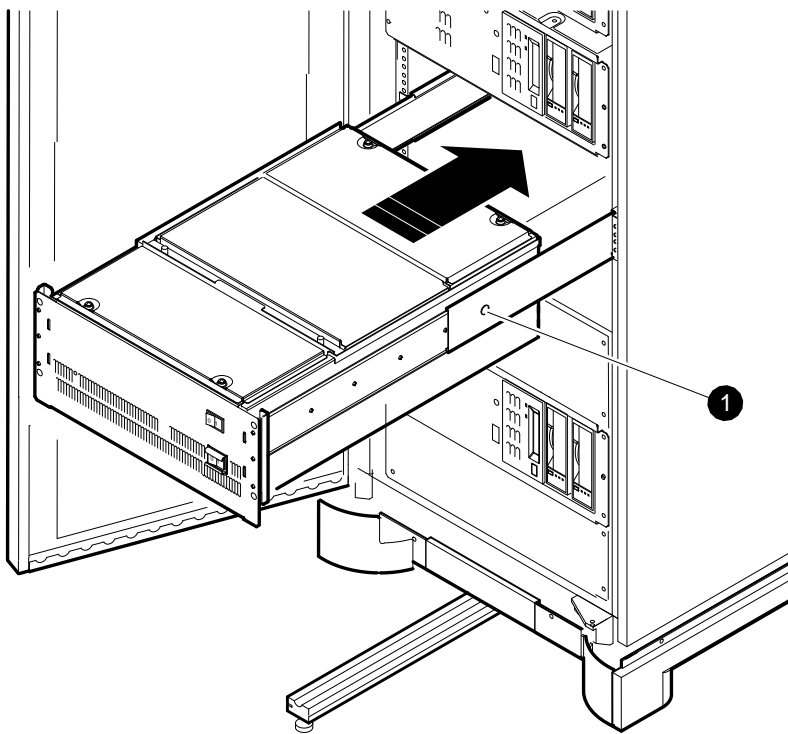

MLO-007754

- ❶ Spring tab in hole

2.5 CPU Drawer Compartments and Covers

The CPU power supply, blower, air plenum, and CPU and TURBOchannel Extender module compartments (identified in Figure 2–8) are accessed by pulling out the CPU drawer on its slides and opening the appropriate cover. To remove the CPU/daughter card, you must open the CPU compartment.

There are three covers on the CPU drawer (shown in Figure 2–8). Use Table 2–1 to determine which cover to raise to access system components.

Table 2–1 CPU Drawer Covers

Cover Location	Accesses
Front	Blower and CPU power supply
Middle	CPU/daughter card, system module, memory, air plenum, TURBOchannel Adapter and options
Rear	TURBOchannel Extender module and options

Note

All FRU services may be accomplished without removing the CPU drawer from the cabinet.

Figure 2-8 CPU Drawer Compartments and Covers

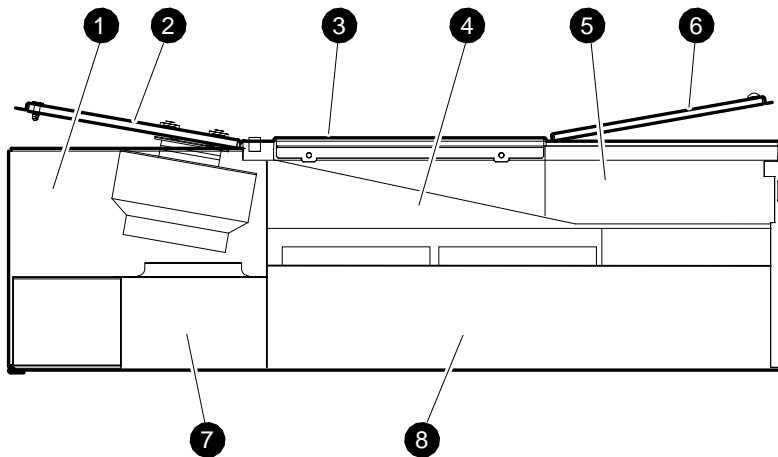

MLO-007707

- ❶ Blower compartment
- ❷ Front top cover
- ❸ Middle top cover (with attached air plenum)
- ❹ Air plenum compartment
- ❺ TURBOchannel Extender compartment
- ❻ Rear top cover
- ❼ Power supply compartment
- ❽ CPU compartment

2.6 Opening and Closing the CPU Drawer Middle Top Cover

To open the middle top cover of the CPU drawer (air plenum compartment), pull out the CPU drawer as described in Section 2.4. Lifting up the middle top cover will also lift the TURBOchannel Extender compartment (see Section 2.5), but will not allow access to it; the rear top cover must be raised to access the TURBOchannel Extender compartment.

1. Using a slotted screwdriver, loosen the two captive screws along the middle edge of the top cover of the drawer (see Figure 2-9).

2. Lift up the middle top cover (air plenum compartment) by grasping the handle on the top and lifting it up and back into an upright position.
 3. Slide the latch to the right to hold the cover in place (see Figure 2–10).
- To close the cover, reverse the above procedures.

Figure 2–9 Opening the Middle Top Cover

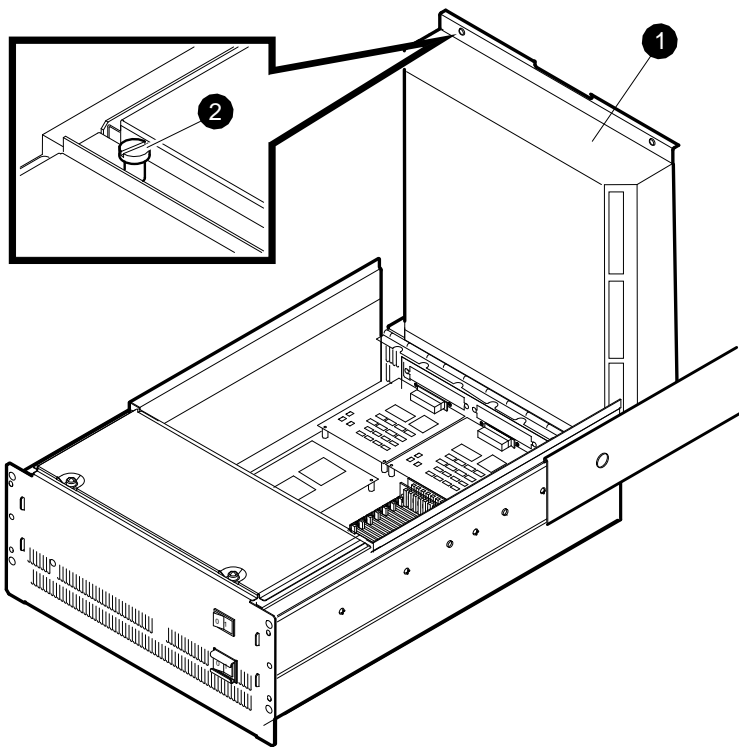

MLO-007756

- ❶ Middle top cover
- ❷ Screws

Figure 2-10 Latching the Middle Top Cover Upright

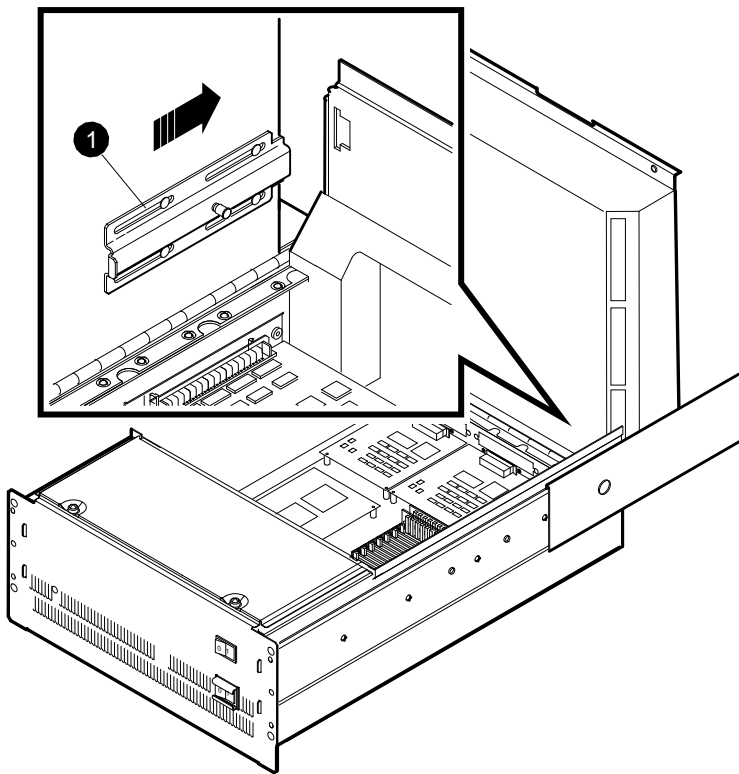

MLO-007757

- 1 Latch

WARNING

Be sure the air plenum compartment is latched in an upright position before proceeding.

2.7 Removing and Replacing the CPU/Daughter Card

Use the standoff removal tool (74-46254-01) to remove the R3000A CPU/daughter card (see Figure 2-11).

1. Compress the standoffs one at a time by placing the tool over them.
2. Gently lift upward on each corner of the card as the corresponding standoff is compressed, leaving the card resting loosely on each standoff until all four corners are lifted.
3. After all corners are resting loosely on the standoffs, grasp the card at each end and lift it up and off the standoffs.
4. Place the R3000A CPU/daughter card on an antistatic mat.

Figure 2–11 Removing the R3000A CPU/Daughter Card

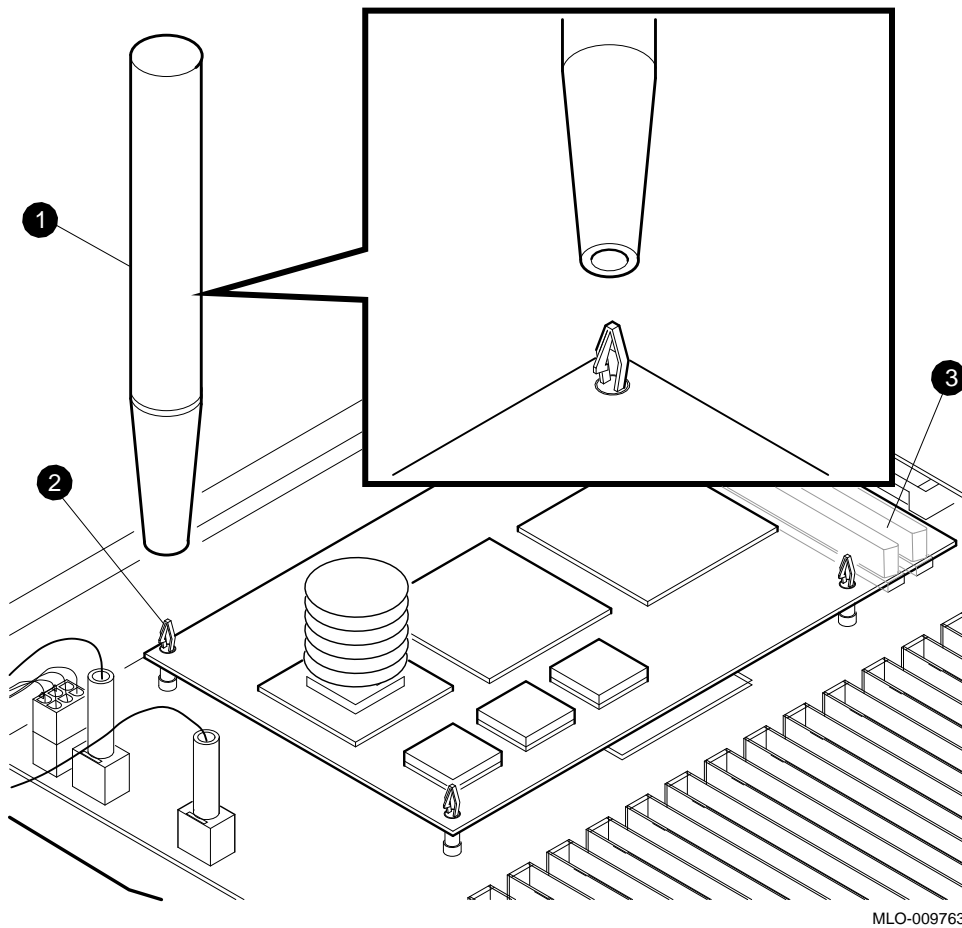

MLO-009763

- ❶ Standoff removal tool
- ❷ Standoff
- ❸ Connectors

5. Place the R4400 CPU/daughter card over the standoffs; do not snap the corners down into place until the connector is positioned to seat properly so as to avoid bending the connector pins. Starting with the connector end of the card, push the card gently straight down onto the connectors and standoffs

until they snap into place, then seat the card onto the standoffs on the other end (see Figure 2–12).

Figure 2–12 Installing the R4400 CPU/Daughter Card

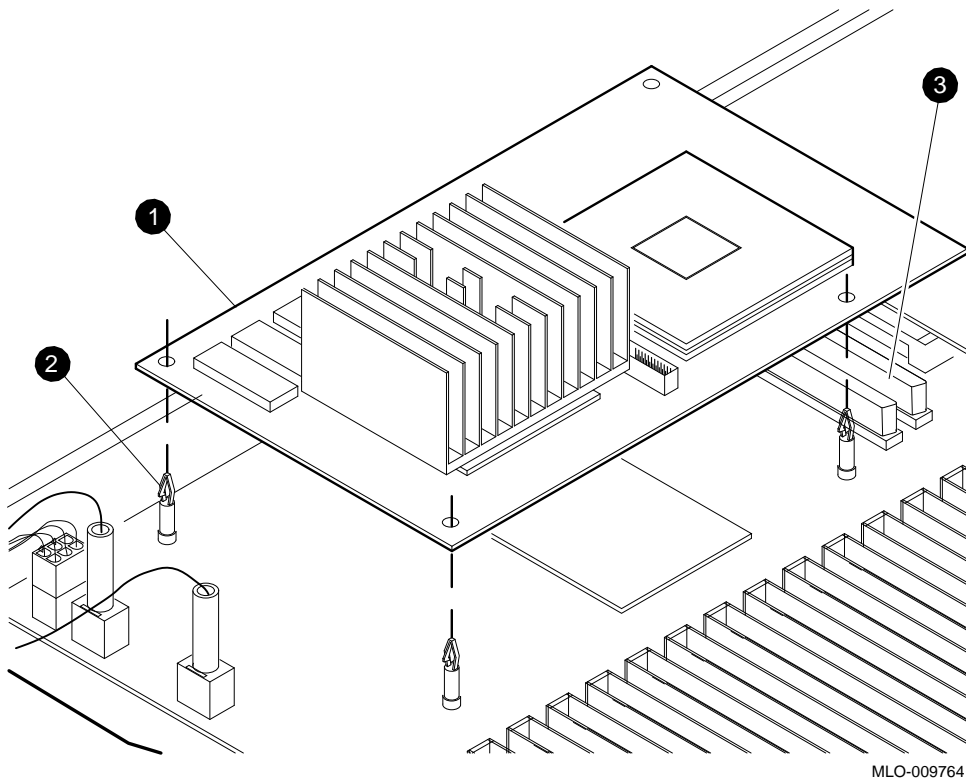

MLO-009764

- ❶ R4400 CPU/daughter card
- ❷ Standoff
- ❸ Connectors

Note

Pack and return the used R3000A CPU/daughter card to Digital Equipment Corporation to avoid the penalty charge. See Appendix A for packaging and shipping instructions.

6. Close the middle top cover of the CPU drawer (see Section 2.6).

2.8 Installing the EMI Grounding Material

Install the EMI grounding material as shown in Figure 2–13:

1. Peel the paper backing strip ❶ off each of the two pieces.
2. Slide both pieces of EMI grounding material firmly down into the front edge of the air plenum compartment cover as shown in ❷.
3. The EMI grounding strip must be in tight contact with both the top front cover of the drawer ❸ and the front of the air plenum compartment cover ❹.

Figure 2-13 Installing the EMI Grounding Material

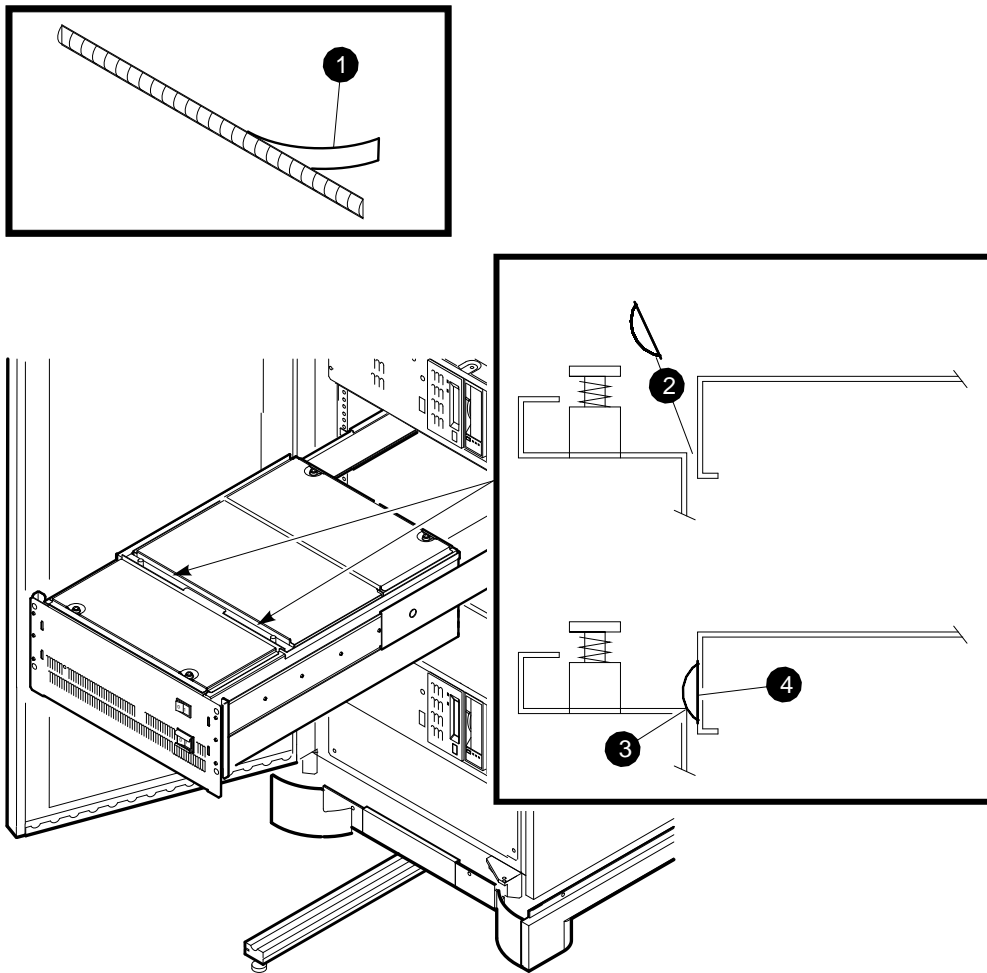

MLO-010174

2.9 Installing the Conversion Label

Fill in the appropriate information on the conversion label 36-15946-XY, (change from "DECsystem 5900 system" to "DECsystem 5900/260 system"), and attach the label on the top front cover of the CPU drawer. See Figure 2-14.

Figure 2-14 Conversion Label Location

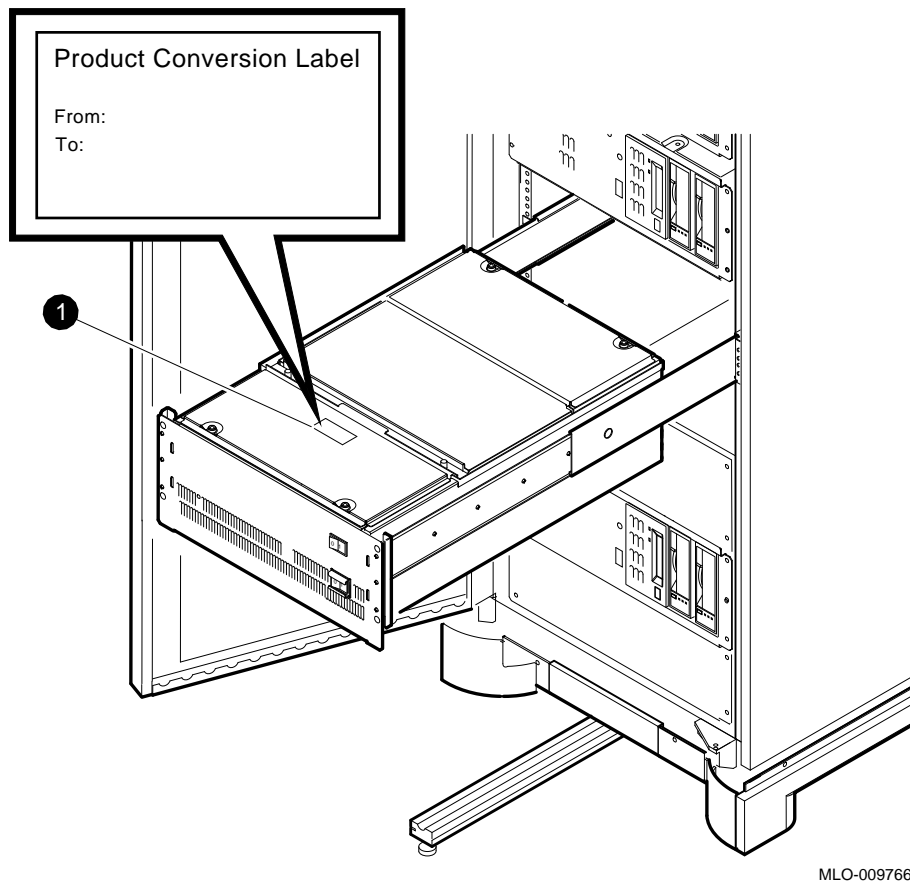

- ❶ Conversion label

2.10 Completing the Installation

Complete the installation by reversing steps from the above procedures and changing the system medallion.

1. Push in the drawer and reinstall all screws (see Section 2.4).
2. Retract the stabilizer bar (see Section 2.3).
3. Turn on the system using the circuit breaker on the power controller and the system power switch (see Section 2.2).
4. Close the enclosure doors (see Section 2.1).

5. Remove the old system medallion and replace it with the new medallion (see Figure 2–15).
 - a. Remove the old medallion by using a flat-bladed screwdriver to lift it off the front panel.
 - b. Attach the new medallion.

Figure 2–15 Medallion Location

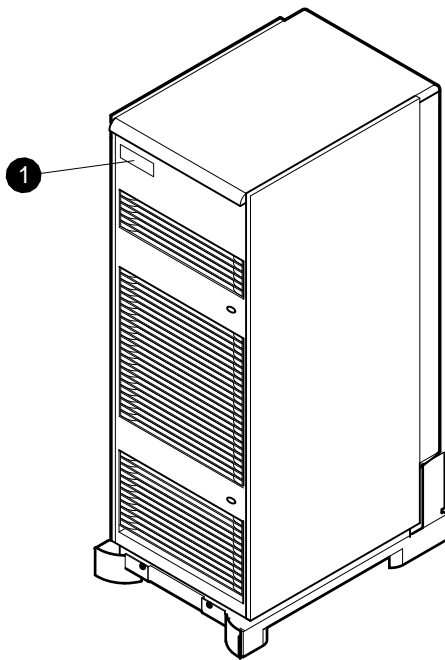

MLO-009765

1 Medallion

6. Run the acceptance tests described in Chapter 3.
7. Modify ULTRIX (see Chapter 3).
8. Have the customer reinstall the system backup data.
9. Fill out the forms in Appendix A and return the R3000 CPU/daughter card as instructed.

3

Diagnosics and Testing

3.1 Acceptance Testing

The following tests ensure that the CPU/daughter card you just installed is in proper operating condition. In addition, problems such as cabling or configuration will be found before the operating system is loaded/booted.

Note

These procedures are an overview of the acceptance testing steps. Detailed information can be found in the *DECsystem 5900 Service Guide*, EK-D590A-PS.

3.1.1 Power-Up Self-Test (POST)

1. Turn on the upgraded CPU drawer.
2. Watch the console terminal for a running display of the POST tests. Most will overwrite the display from previous tests as they are run.
There should be no errors in this 2-minute (approx.) test.
3. If there is no display, look for a green power LED on the front of the drawer, and see if the red LEDs on the rear of the CPU drawer are changing state as the tests run. If the LEDs are not on, check for a power or cabling problem.

3.1.2 System Configuration Check

Use the cnfg utility to assure that the system can "see" all the memory modules, NVRAM, TURBOchannel options and SCSI devices. There can only be *one* SCSI device 0, 1, 2, 3, 4, 5, or 6 on *each* SCSI bus.

Pay particular attention to SCSI IDs on configurations that use split SCSI format or have two CPUs sharing a single mass storage drawer. If the system cannot see all the devices on each SCSI bus or on the system module, check the cable/module connections or the SCSI IDs.

Run config by entering **cnfg x** where x = the TURBOchannel bus ID: 0, 1, 2, or 3; 3 is also used for the system module.

3.1.3 Extended ROM Tests

Run the extended tests on memory, cache, floating point, Ethernet, prcache and TLB. Use of the **-l** command option in the command string (**t -l 3/misc/halt**) will cause the tests to loop until a **^c** is typed. Table 3–1 is provided as a guideline.

Table 3–1 Individual Module/Device Tests

Individual Test	Test Command
System Module	
Halt button	t 3/misc/halt n[0] ¹
Nonvolatile RAM	t 3/rtc/nvr [pattern] ²
Overheat detect	t 3/overtemp
Real-time clock period	t 3/rtc/period
Real-time clock register	t 3/rtc/regs
Real-time	t 3/rtc/time
SCC ³ access	t 3/scc/access
SCC DMA	t 3/scc/dma line[2] int/ext[I] bd[38400] pa[none] bits[8] ⁴
SCC interrupt	t 3/scc/int line[0] ⁴
SCC I/O	t 3/scc/io line[0] int/ext[I] ⁴
SCC pins	t 3/scc/pins line[2] loopback[29-24795-00] ⁴
SCC xmit and receive	t 3/scc/tx-rx line[2] int/ext[I] bd[9600] pa[none] bits[8] ⁴
NVRAM	t 3/prcache
NVRAM clear	t 3/prcache/clear
NVRAM battery enable	t 3/prcache/unarm
NVRAM battery disable	3/prcache/arm

¹[0] = [1-9] = press halt the same number of times (1-9)

²[pattern] 55 is the default pattern

³Serial communications chip

⁴Conventions used in SCC tests. line, serial line to test, 2 is rightmost from back 3 is leftmost. int/ext is internal or external loopback. bd is baud rate. pa is parity. bits is data bits. loopback specifies the type of loopback used in the pins test. The value in [] specifies the default.

(continued on next page)

Table 3–1 (Cont.) Individual Module/Device Tests

Individual Test	Test Command
System Module	
Ethernet Controller	
Collision	t 3/ni/llsn
Cyclic redundancy code	t 3/ni/crc
Display MOP counter	t 3/ni/ctrs
DMA registers	t 3/ni/dma1
DMA transfer	t 3/ni/dma2
ESAR ⁵	t 3/ni/esar
External loopback	t 3/ni/ext-lb
Internal loopback	t 3/ni/int-lb
Interrupt request (IRQ)	t 3/ni/int
Multicast	t 3/ni/m-cst
Promiscuous mode	t 3/ni/promisc
Registers	t 3/ni/regs
SCSI Controller and Drives	
SCSI controller	t 3/scsi/cntl
SCSI send diagn	t 3/scsi/sdiag [scsi_id] [d] [u] [s] ⁶
SCSI target	t 3/scsi/target [scsi_id] [w] [l #] ⁶
CPU Card	
Cache data test	t 3/[cache] [address] ⁷
Secondary cache data test	t 3/scache/data
Cache fill	t 3/cache/fill [cache] [offset] ⁷

⁵Ethernet station address ROM

⁶Replace the scsi_id with the device id # that you want to test. 0 is the default. [d] and [u] are device-specific parameters. Reference the device manuals for more details. Leave to default if unsure. [s] suppresses error messages (not normally set). [w] if specified will perform a write test to the device called out in the SCSI target test. *Caution: This can cause data loss. Run this command only on hard disks that have no data or on tapes with scratch media installed.*

⁷Replace [cache] with I (instruction) or D (data) to specify which cache to test. Data cache is default. Default [offset] is 80500000. You can replace with the address where you want the test to start. [address] is not normally entered.

(continued on next page)

Table 3–1 (Cont.) Individual Module/Device Tests

Individual Test	Test Command
Cache isolate	t 3/cache/isol [cache] ⁷
Cache reload	t 3/cache/reload [cache] [offset] ⁷
Cache segment	t 3/cache/seg [cache] [address] ⁷
CPU-type	t 3/misc/cpu-type
Floating-point unit	t 3/fpu
Translation lookaside buffer probe	t 3/tlb/prb
TLB reg	t 3/tlb/reg [pattern] [pattern] ⁸
Memory Modules	
Floating I/O	t 3/mem/float10 [address] ⁹
Memory module	t 3/mem [module] [threshold] [pattern] ⁹
RAM address select lines	t 3/mem/select
Partial write	t 3/misc/wbpart
Initialize memory	t 3/mem/init

⁷Replace [cache] with I (instruction) or D (data) to specify which cache to test. Data cache is default. Default [offset] is 80500000. You can replace with the address where you want the test to start. [address] is not normally entered.

⁸[pattern] default is 55555555. Pattern can be entered if needed.

⁹You can enter the starting [address]. A0100000 is default. Module # default is 0. You can specify module [module]. A data pattern can be specified [pattern].

3.1.4 SCSI Test Commands

Note

For more detailed information consult the *DECsystem 5900 Service Guide*, EK–D590A–PS.

To test SCSI controllers, configurations, and new devices that were added, run the `scsi/cntl` (SCSI controller), `scsi/sdiag` (send diagnostic), and the `scsi/target` tests (test SCSI devices) on the SCSI controller(s) and newly added SCSI devices.

Caution

The [w] parameter on the scsi/target test may cause data loss; use it only on newly installed disk devices which have no data on them, or use a scratch tape in tape devices.

3.2 Modifying ULTRIX

These steps will vary with the scope of the changes to the system configuration that have been made during the CPU/daughter card upgrade. Depending on the site, you and/or the customer/system manager should consult the *Guide to Installing ULTRIX*, AA-PBL0D-TE, and other ULTRIX documentation for more details on adding devices.

A

Mandatory Card Return Procedure and Forms

The used R3000A CPU/daughter card must be returned to Digital Equipment Corporation. Digital Services personnel must ensure that the instructions to repackage and return used CPU/daughter cards are followed. The instructions apply only to United States area installations.

For installations outside the United States area, contact the local Digital Equipment Corporation office for return destination instructions.

A.1 Return Procedure

Return the CPU/daughter card as follows:

1. Obtain the serial number of the system being converted. Customer Administrative Services (CAS), cannot process the order without this serial number.
2. Ensure that the serial number is on the purchase order.
3. Issue a hardcopy quotation to the customer, referencing the serial number, and state the following:

"Return of the replaced card to Digital is a condition of sale for this conversion. Failure to return the card will result in a penalty charge. Installation of hardware by Digital Services personnel is required."
4. Pack the used card with the packaging material set aside from the carton of the conversion kit, first in the nickel-plated bag, then in the pink plastic wrapping, and finally in the box.
5. Complete the Digital Services Worksheet in Section A.2. It documents the work you performed.

Return the worksheet to your contract administrator at the branch office.

6. Contact your local Digital CAS office to obtain information for the Installation Receipt and the Return Material Checklist in Section A.2. Section A.3 lists the CAS district offices and their phone numbers.

Ask the CAS representative for a return authorization (RA) number. CAS will contact the customer to arrange for carrier pickup and return of the card to Digital Equipment Corporation.

7. Complete both copies of the Installation Receipt.

The first copy is the customer's receipt. It shows that the installation was completed and that Digital Services contacted CAS.

Return the second copy to Digital Services along with the used card to ensure that the customer does not incur a penalty charge.

8. Complete the Returned Material Checklist.

Return the checklist with the used card.

9. Place the self-adhesive mailing label on the box to be returned.

Write the return authorization (RA) number in the space provided on the label.

10. Seal the box for shipment.

Refer questions regarding the return procedure to the local account representative.

Note

Customers who do not return their used CPU cards will be charged a fee.

A.2 Return Forms

This section contains the:

- Digital Services Worksheet
- Installation Receipt: Customer Copy
- Installation Receipt: Digital Services Copy
- Returned Material Checklist

Digital Services Worksheet

This form acts as a verification of the work performed on the system and as a check on the procedures used. Fill out applicable sections of this form and return it to your Contract Administrator for updating the customer's contract.

Customer: _____

Previous System Model Number: _____

Previous System Serial Number: _____

Previous CPU Card Serial Number: _____

New System Name: _____

New System Model Number: _____

New System Serial Number: _____

New CPU Card Serial Number: _____

Comments: _____

Installation Receipt—Customer Copy

For the conversion of a DECsystem 5900 system to a DECsystem 5900/260 system.

This form acts as a customer receipt and as verification for Digital Services that the DECsystem 5900/260 conversion kit was installed.

Digital Services: Complete both copies of this form. Give the Customer Copy to the customer and the Digital Services Copy to the local CAS office for filing with customer documents.

Contact the local CAS office to obtain the RA (return authorization) number. See Section A.3 for the closest CAS office. You should have the Digital order number available. Be sure to note the name of the person with whom you speak.

Customer: Digital Equipment Corporation will contact you within the next several days to arrange for package pickup and return. Keep this copy as your record of installation by Digital Equipment Corporation.

Name of CAS representative: _____

Branch Office: _____, will arrange for package pickup and return.

Return Authorization (RA) Number: _____

Digital Order Number: _____

Previous CPU Card Serial Number: _____

New CPU Card Serial Number: _____

New System Serial Number: _____

Installation was performed on this date: _____

Card Packed for Return:

Customer Name: _____ Phone Number: _____

Customer Signature: _____

Digital Services Representative Signature: _____

Installation Receipt—Digital Services Copy

For the conversion of a DECsystem 5900 system to a DECsystem 5900/260 system.

This form acts as a verification for Digital Services that the DECsystem 5900/260 conversion kit was installed.

Digital Services: Complete both copies of this form. Give the Customer Copy to the customer and the Digital Services Copy to the local CAS office for filing with customer documents.

Contact the local CAS office to obtain the RA (return authorization) number. See Section A.3 for the closest CAS office. You should have the Digital order number available. Be sure to note the name of the person with whom you speak.

Name of CAS representative: _____

Branch Office: _____, will arrange for package pickup and return.

Return Authorization (RA) Number: _____

Digital Order Number: _____

Previous CPU Card Serial Number: _____

New CPU Card Serial Number: _____

New System Serial Number: _____

Installation was performed on this date: _____

Card Packed for Return:

Customer Name: _____ Phone Number: _____

Customer Signature: _____

Digital Services Representative Signature: _____

Returned Material Checklist

For the conversion of a DECsystem 5900 system to a DECsystem 5900/260 system.

This form acts as a customer receipt and as verification for Digital Services that the DECsystem 5900/260 conversion kit was installed.

Return Authorization (RA) Number: _____

Digital Order Number: _____

Customer Name: _____

Customer Address: _____

Customer Contact: _____

******* Include This Form with Your Card Return*******

A.3 Customer Administrative Services (CAS) District Offices

Name, Location	Phone Number
Allegheny District, Pittsburgh, PA	(412) 244-7410
Carolinas District, Columbia, SC	(803) 798-6477
Chicago District, Chicago, IL	(312) 806-2478
Connecticut District, Meriden, CT	(203) 634-5325
CSS District, Nashua, NH	(603) 884-6549
DECdirect District, Nashua, NH	(603) 884-9115
Florida District, Tampa, FL	(813) 882-6822
Greater Boston District, Waltham, MA	(617) 895-5455
Great Lakes District, Detroit, MI	(313) 344-2285
Los Angeles District, Culver City, CA	(213) 417-4232
Midsouth District, Memphis, TN	(901) 761-6712
New England District, Bedford, MA	(603) 472-6061
New Jersey Commercial District, Piscataway, NJ	(201) 562-4728
New Jersey Financial District, New York, NY	(212) 714-2648
New York Financial District, New York, NY	(212) 714-2648
New York Suburban District, Tarrytown, NY	(914) 524-5284
North Central District, Minneapolis, MN	(612) 851-2225
North Texas/Oklahoma District, Dallas, TX	(214) 404-6135
Northwest District, Bellevue, WA	(206) 462-2540
Ohio Valley District, Cincinnati, OH	(513) 984-7739
Philadelphia District, Blue Bell, PA	(215) 834-4115
Rocky Mountain District, Englewood, CO	(303) 649-3073
Santa Clara District, Santa Clara, CA	(408) 496-4274
Southeast District, Atlanta, GA	(404) 257-2282
Southern California District, Costa Mesa, CA	(714) 850-7606
South Texas District, Houston, TX	(713) 953-3918
Southwest District, Tempe, AZ	(602) 894-4747

Name, Location	Phone Number
Upstate New York District, Rochester, NY	(716) 385-7152
U.S. Distribution/Sales District, Marlboro, MA	(508) 480-4259
Virginia District, Landover, MD	(301) 306-2566
Washington DC District, Landover, MD	(301) 459-2890
Washington DC District, FDA Landover, MD	(301) 459-2292

Reader's Comments

DECsystem 5900/260
CPU Card Installation
EK-D5960-IN. A01

Your comments and suggestions help us improve the quality of our publications.

Please rate the manual in the following categories:

	Excellent	Good	Fair	Poor
Accuracy (product works as described)	<input type="checkbox"/>	<input type="checkbox"/>	<input type="checkbox"/>	<input type="checkbox"/>
Completeness (enough information)	<input type="checkbox"/>	<input type="checkbox"/>	<input type="checkbox"/>	<input type="checkbox"/>
Clarity (easy to understand)	<input type="checkbox"/>	<input type="checkbox"/>	<input type="checkbox"/>	<input type="checkbox"/>
Organization (structure of subject matter)	<input type="checkbox"/>	<input type="checkbox"/>	<input type="checkbox"/>	<input type="checkbox"/>
Figures (useful)	<input type="checkbox"/>	<input type="checkbox"/>	<input type="checkbox"/>	<input type="checkbox"/>
Examples (useful)	<input type="checkbox"/>	<input type="checkbox"/>	<input type="checkbox"/>	<input type="checkbox"/>
Table of contents (ability to find topic)	<input type="checkbox"/>	<input type="checkbox"/>	<input type="checkbox"/>	<input type="checkbox"/>
Index (ability to find topic)	<input type="checkbox"/>	<input type="checkbox"/>	<input type="checkbox"/>	<input type="checkbox"/>
Page design (overall appearance)	<input type="checkbox"/>	<input type="checkbox"/>	<input type="checkbox"/>	<input type="checkbox"/>
Print quality	<input type="checkbox"/>	<input type="checkbox"/>	<input type="checkbox"/>	<input type="checkbox"/>

What I like best about this manual: _____

What I like least about this manual: _____

Additional comments or suggestions: _____

I found the following errors in this manual:

Page	Description
------	-------------

For which tasks did you use this manual?

Installation

Maintenance

Marketing

Operation/Use

Programming

System Management

Training

Other (please specify) _____

Name/Title _____

Company _____

Address _____

Do Not Tear - Fold Here and Tape

digital

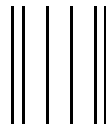

NO POSTAGE
NECESSARY
IF MAILED
IN THE
UNITED STATES

BUSINESS REPLY MAIL

FIRST CLASS PERMIT NO. 33 MAYNARD MASS.

POSTAGE WILL BE PAID BY ADDRESSEE

**DIGITAL EQUIPMENT CORPORATION
INFORMATION DESIGN AND CONSULTING
PKO3-1/D30
129 PARKER STREET
MAYNARD, MA 01754-9975**

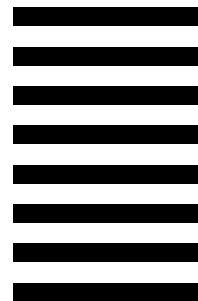

Do Not Tear - Fold Here and Tape