

EK-CMR11-PS-001

**CMR11/CMV11
Distributed
Multiprocess
Controller**

**Pocket
Service
Guide**

digital

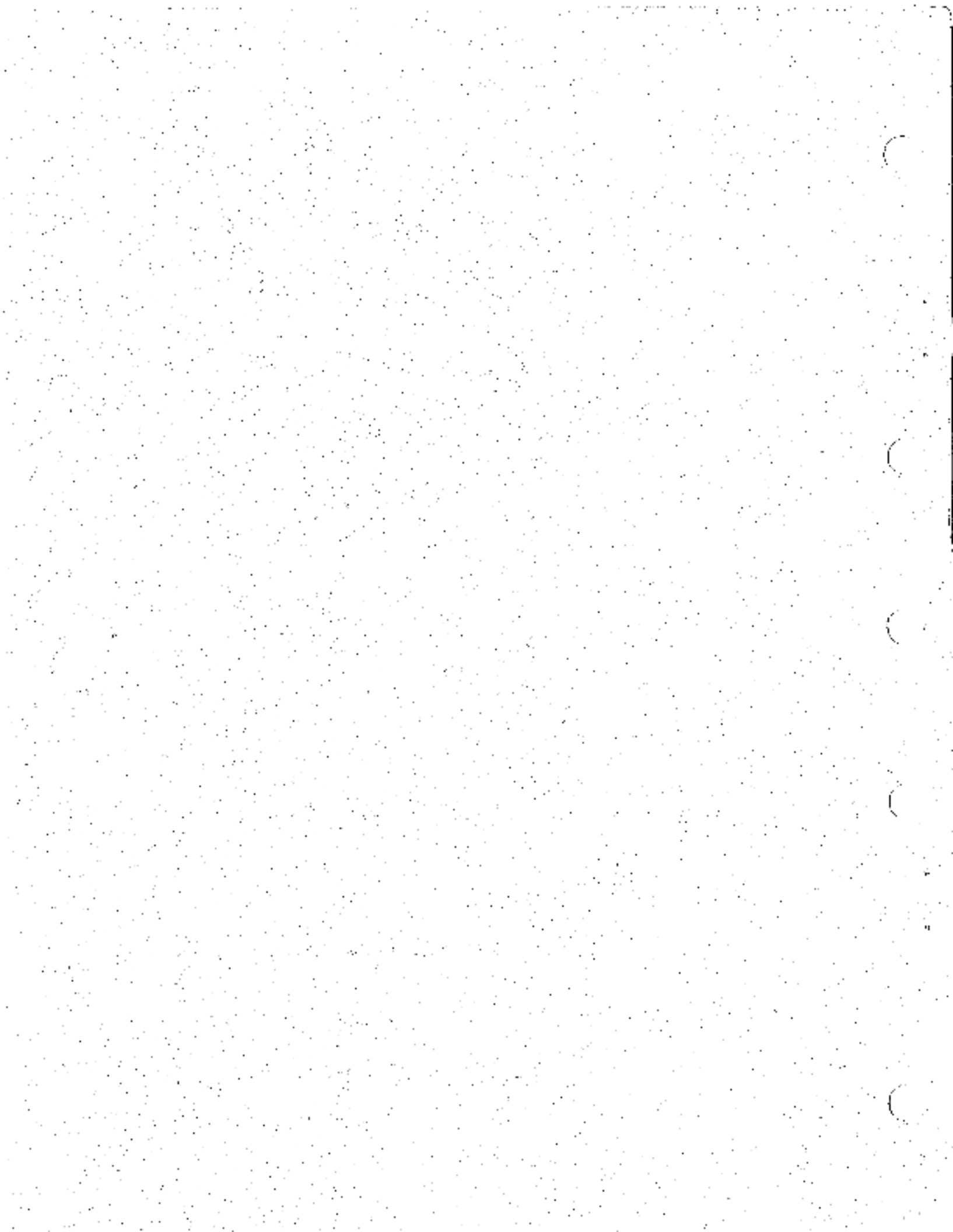

EK-CMR11-PS-001

**CMR11/CMV11
Distributed
Multiprocess
Controller**

**Pocket
Service
Guide**

Prepared by Educational Services
of
Digital Equipment Corporation

1st Edition, July 1982

Copyright © 1982 by Digital Equipment Corporation

The material in this manual is for informational purposes and is subject to change without notice.

Digital Equipment Corporation assumes no responsibility for any errors which may appear in this manual.

Printed in U.S.A.

This document was set on DIGITAL's DECset-8000 computerized typesetting system.

The following are trademarks of Digital Equipment Corporation, Maynard, Massachusetts:

DIGITAL	DECsystem-10	MASSBUS
DEC	DEC SYSTEM-20	OMNIBUS
PDP	DIBOL	OS/8
DECUS	EDUSYSTEM	RSTS
UNIBUS	VAX	RSX
	VMS	

CONTENTS

PREFACE

1 INTRODUCTION

1.1	General	1
1.2	Physical/Functional Description	1
1.2.1	CMR11 Host Controller Component Summary	1
1.2.2	CMR01 Remote Unit Component Summary	4
1.2.3	Specifications	5

2 BOARD CONFIGURATIONS

2.1	General	9
2.2	CMR11/CMV11 Reference Documentation	9
2.3	CMR11/CMV11 Components List	9
2.4	I/O Control Modules/ Terminators	12
2.5	CMR11/CMV11 Power) Bus Loading	12
2.6	Configuration Variables	15
2.6.1	CMR11/CMV11 Host Considerations	15
2.6.2	CMR01 Remote Unit Considerations	17
2.7	Installation Checkout	25
2.8	Cabling and Test Connectors	25

3 TEST AND CALIBRATION

3.1	Introduction	35
3.2	Diagnostic Summary	35
3.3	Test Descriptions	37
3.3.1	Sub Test 1	37
3.3.2	Sub Test 2	37
3.3.3	Sub Test 3	38
3.4	CMR11/CMV11 Host Controller Checkout	40
3.5	CMR01 Remote Checkout Procedures	40
3.5.1	Maintenance Display Panel	40

iv CONTENTS

3.5.2	CMR01 Basic Test Procedure	46
3.5.3	CMR01 Remote I/O Controller Test Procedure	49
3.5.4	CMR01 Communications Line Adjustments.....	77
4 CORRECTIVE MAINTENANCE		
4.1	General.....	83
4.2	Maintenance Features	83
4.3	Register Bit Assignments.....	88
4.4	Teach-Tips/FCO Index.....	88

FIGURES

1-1	CMR11/CMV11 Basic Host Controller Diagram.....	3
1-2	CMR01 Remote Basic Diagram.....	7
2-1	CMR11 (M8990) Device Address/Host Baud Rate Selection.....	18
2-2	CMR11 (M8990) Vector Address Selection.....	19
2-3	CMV11 (M7187) Device Address/Host Baud Rate Selection (Ports 0-1).....	20
2-4	CMV11 (M7187) Vector Address Selection.....	21
2-5	CMV11 Host Baud Rate Selection (Ports 2-3).....	22
2-6	Host LDM (M8996) Modem Variables.....	23
2-7	Remote (M9052) Configuration Variables.....	24
2-8	CMR11/CMV11 Installation Flowchart.....	26
2-9	CMR01 Installation Flowchart.....	29
2-10	CMR11/CMV11 Cabling Diagram/Test Connector Placement.....	31
2-11	CMR11/CMV11 Cables.....	32
2-12	CMR11/CMV11 Test Connectors.....	33

CONTENTS v

3-1	(C)ZCMJ Test 1 Sample Printout	37
3-2	(C)ZCMJ Test 2 Sample Printout	38
3-3	(C)ZCMJ Test 3 Sample Printout (No Status Changes)	39
3-4	(C)ZCMJ Test 3 Sample Printout (with Status Changes)	39
3-5	CMR11/CMV11 Checkout Procedures	41
3-6	CMR01 Maintenance/Display Panel	43
3-7	Basic CMR01 Test Procedure	46
3-8	CMR01 Remote Unit LED Legend	48
3-9	M8995 Switch Locations	49
3-10	G5153 Digital I/O Pulse Count Test Module	50
3-11	CMRT1-1 Signal Conditioning Paddleboard (M9052)	51
3-12	BC08R Test Interconnect	52
3-13	A605 Analog I/O Test Module	53
3-14	A805 Test Configuration	54
3-15	A805 Checkout Procedure	55
3-16	A805 Calibration Procedure	59
3-17	A805 Adjustments	62
3-18	A6005 Test Configuration	63
3-19	A6005 Checkout Procedure	64
3-20	A6005 Calibration Procedures	67
3-21	A6005 Adjustments	68
3-22	A1004/A1005 Checkout Procedure	69
3-23	M8986, M8987, or M8994 Checkout Procedures	73
3-24	M8993 Checkout Procedure	75
3-25	M8997 Checkout Procedure	78
3-28	CMR01 Communications Line Adjustments	80
4-1	CMR11/CMV11 Troubleshooting Flowchart	86
4-2	CMR11/CMV11 Register Bit Assignments	88

vi CONTENTS

TABLES

2-1	CMR11/CMV11 Components List.....	10
2-2	CMR01 Components List	11
2-3	Optional I/O Module List	13
2-4	CMR/CMV11 Module Input Voltage Chart.....	14
2-5	CMR01 Remote Unit Voltage Chart	15
2-6	CMR01 Optional Module Voltage Chart.....	16
3-1	CMR11 Error Codes	44
3-2	Valid Test Results	72
3-3	M8993 Test Results	77

PREFACE

The *CMR11/CMV11 Distributed Multiprocess Controller Pocket Service Guide* provides field service engineers with a quick-reference guide to help troubleshoot and maintain the CMR11/CMV11 controller to a field replaceable unit (FRU).

Additional information may be found in the reference documents listed below:

- *CMR11 System Option Description* (YC C318C-00)
- *CMR11 Product Description* (YC-AB09-00)
- *CMR11 Engineering Drawings* (MP-01287-00)
- *CMV11 Engineering Drawings* (MP-01288-00)



1 INTRODUCTION

1.1 GENERAL

The Compact Micro-Remote (CMR11/CMV11) system is a distributed multiprocess control device that controls and monitors a variety of I/O functions from one PDP-11 host computer system.

The CMR11/CMV11 uses a microprocessor-based controller at the host that is capable of distributed processing over multipoint communications facilities. Up to 252 EIA RS-232-C interface remote units or 64 limited distance modem (LDM) remote units can be controlled by the host controller. The remote units are standalone, firmware-based devices capable of controlling and monitoring 16 different I/O modules.

1.2 PHYSICAL/FUNCTIONAL DESCRIPTION

Hardware for the CMR11/CMV11 system is logically separated into two distinctive sections:

1. The CMR11/CMV11 host controller, and
2. The CMR01 remote unit.

A brief description of each is provided in the following sections.

1.2.1 CMR11 Host Controller Component Summary

The CMR11/CMV11 host controller, physically located at the site of the CPU, consists of the following three basic components:

- Host controller microprocessor

CMR11-AA - A single hex-height module (M8990) that mounts in any SPC UNIBUS slot.

CMV11-AA - Two dual-height modules (M7181 and M7182) that mount in any LSI-11 Q-BUS slot.

2 INTRODUCTION

- Communication panel assembly

CMR11-01 panel assembly - Includes one LDM module (M8996). Has three additional locations for add-on M8996 modules. Also includes 2C-HY38A-06 cable assembly.

- Add-on module

- CMR11-02 - Includes one add-on LDM (M8996) module and 2C-HY38A-06 cable assembly.

The host controller module interfaces the UNIBUS or Q-BUS to the M8996 LDM. The LDM in turn provides the signal conversion necessary for interfacing to the network. Figure 1-1 is a basic diagram of the host controller configuration.

Three communication configurations are possible:

1. EIA RS-232-C using modems,
2. CMR on-board limited distance modems, or
3. A combination of both.

Typical network schemes are:

- Single or multiple CMR remotes with LDMs (located adjacent to the host or distributed throughout a building) operating over 2-wire or 4-wire private lines at rates up to 9600 baud.
- LDMs connected to dedicated leased telephone lines at speeds up to 2400 baud (depending on the number of remotes and the line distances involved).
- EIA RS-232-C modems operating long distance over leased telephone lines.
- EIA RS-232-C modems used to communicate with the first of a cluster of CMR01 remotes after which the remaining remotes of the cluster may use LDM communications.

A variety of communication line speeds are possible because each host unit has four individual communication ports. The total number of remote units may be evenly divided among the four ports. Each port can select either 300, 600, 1200, 2400, 4800, or 9600 baud.

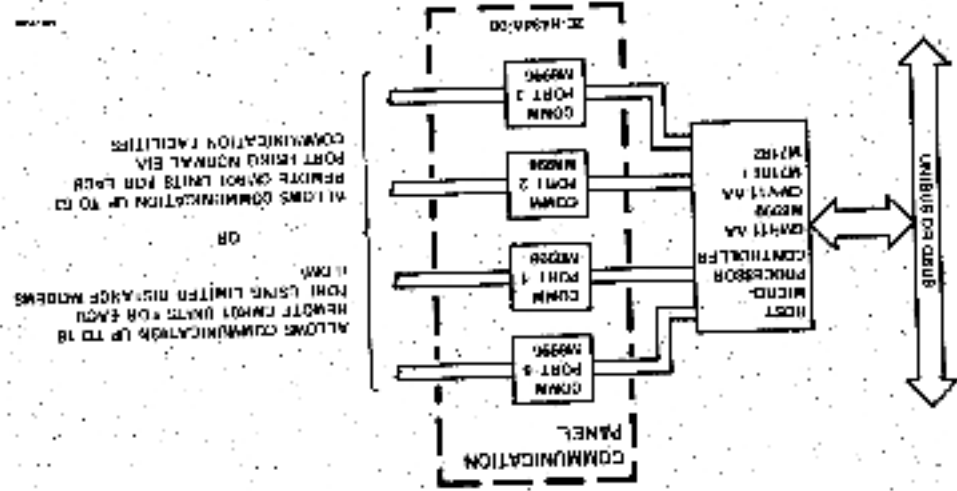

Figure 1-1 CMRA1/CMV11 Based Host Controller Diagram

4. INTRODUCTION

The individual baud-rate selector switches offer a convenient and easy means of providing high-speed communications to short distance remotes, while at the same time, establishing lower baud rates for ports connected to long distance remotes.

1.2.2. CMR01 Remote Unit Component Summary

The CMR01 remote unit is a self-contained, rack mounted unit, consisting of five major component areas. It is physically located at the site where process control is taking place. The five major component areas are:

1. Remote controller microprocessor modules (M8991 and M8992);
2. Limited distance modem (LDM) module (M8995);
3. Remote I/O process control modules (optional):
 - a. 16-point (bit) optically coupled digital input modules.
 - b. 16-point (bit) digital output modules.
 - c. 4-channel optically coupled pulse counter modules.
 - d. Analog to digital (A/D) converter modules.
 - e. 8-channel analog input multiplexer modules, and
 - f. 2-channel analog output modules.
4. Maintenance display panel. Includes the M9053 remote connector module; and
5. AC/DC power supply. DC feature is optional. If selected, unit switches to dc operation if a failure occurs at the ac.

The remote controller modules (M8991 and M8992) interface the remote LDM (M8995) to the I/O process control bus called the R-BUS.

In the normal RUN mode, messages from the host are received through the port, decoded and checked for errors by the remote controller, and then channeled to the correct I/O device.

When not receiving a message or executing a function, the remote controller can be enabled to scan specified channels for alarm conditions. Alarm conditions may be a change in the state of the digital input points or analog

changes beyond specified limits. When an alarm is detected it is stored. When the next interrogation message is received from the host, the CMR01 returns all alarm data.

The remote unit also contains built-in test programs which use the maintenance/display panel to check out the controller or any I/O modules. The panel contains a number of switches and LEDs to facilitate various maintenance functions. These switches and LEDs are discussed in Chapter 2. Figure 1-2 is a basic diagram of the CMR01 remote configuration.

Power for the CMR01 may be either 115 or 230 Vac or optional 12 Vdc (supplied by customer 20 AM battery). When ac power is lost, the unit automatically switches to the optional 12-volt system.

1.2.3 Specifications

• Mechanical

Host Controller

CMR11 - One hex-height module (M8990 - UNIBUS)

CMV11 - Two dual-height modules (M7181 and M7182*) Q-BUS

Remote unit (CMR01)

Height = 30.5 cm (12 in)

Width = 48.3 cm (19 in)

Depth = 27.9 cm (11 in)

Weight = 22.7 kg (50 lbs)

• Electrical

- Normal input power requirements

*The M7182 is a "piggyback" module requiring two adjacent slots. However, it attaches to only one slot for power.

6 INTRODUCTION

CMR01 Option	Max. Current
CMR01-AA 115 Vac	2.5 A
CMR01-AB 230 Vac	1.5 A
CMR01-AC 115 Vac	2.5 A or 12 Vdc* at 30 A
CMR01-AD 230 Vac	1.5 A or 12 Vdc* at 30 A

• Environmental

- Environmental conditions *without* analog circuits:

5° - 50° Celsius

41° - 122° Fahrenheit

Humidity 10 - 95% (Noncondensing)

- Environmental conditions *with* analog circuits:

15° - 32° Celsius

59° - 90° Fahrenheit

Humidity 10 - 90% (Noncondensing)

• Communications

- EIA RS-232-C or limited distance modem
- Baud rates: 300, 600, 1200, 2400, 4800, or 9600 baud
- Baud rate/line length

Voice-grade telephone lines: 2400 baud max.
422 kft (300 miles)

4-wire continuous line: 9600 baud max.
80 km (50 miles)

EIA limitations: 9600 baud max.
No limit to distance

NOTE

Maximum baud rate and maximum distance cannot be achieved together.

*Battery 20 Ampere-hour (Ah)

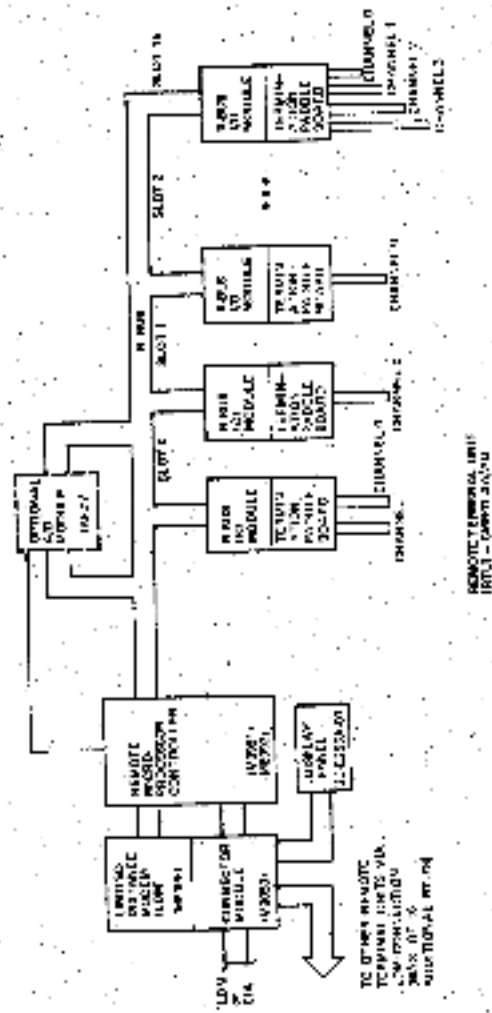

Figure 1-2 CMR01 Remote Basic Diagram



2 BOARD CONFIGURATIONS

2.1 GENERAL

This section provides a summary of key factors concerning certain configuration variables that must be verified during troubleshooting. Board configurations, including jumper and switch selections, and system configurations, including cabling, are included to support the troubleshooting efforts.

2.2 CMR11/CMV11 REFERENCE DOCUMENTATION

Refer to the following documents if the level of content in this section is insufficient.

- *CMR Systems Option Description* VC-C318-C-00
- *CMR11-AA Engineering Drawings* MP-01287
- *CMV11-AA Engineering Drawings* MP-01288
- *CMR11-01/02 Engineering Drawings* MP-01289
- *CMR01 Engineering Drawings* MP-01290

2.3 CMR11/CMV11 COMPONENTS LIST

Tables 2-1 and 2-2 identify the components required to configure the CMR11/CMV11 host and the CMR01 remote unit respectively.

10 BOARD CONFIGURATIONS

Table 2-1 CMR11/CMV11 Components List

Option	Parts List	Description
CMR11-AA	M8990	Basic PDP-11 Host Controller
	YC-4-118C-00	Host Microprocessor Module
	MP-01287-00	Option Description Manual Engineering Print Set for CMR11-AA
	AC-F912B-MC	CZCMJ** Diagnostic Paper Tape
	AK-F913B-MC 2C-HY38A-00	CZCMJ** Diagnostic Listing Host Comm Port Test Connector
CMV11-AA	M7181	Basic VSI-11 Host Controller
	M7182	Host Microprocessor Module #1
	MC05L-1C	Host Microprocessor Module #2
	YC-C218C-00	Module Interconnect Cable
	MP-01288-00	Option Description Manual Engineering Print Set for CMV11-AA
	AC-F912B-MC AK-F913B-MC 2C-HY38A-00	CZCMJ** Diagnostic Paper Tape CZCMJ** Diagnostic Listing Host Comm Port Loopback Test Connector
CMR11-01		Host Communication Panel Assembly
	7C-H444A-00	Communication Panel
	M8996	Host LDM Modem Module
	7C-HY38A-06	CMR LDM Communication Cable
	MP-01289-00	Engineering Print Set for CMR11-01/02
	2C-HY31A-00 2C-HY33A-00	EIA Berg Port Loopback Test Connector LDM Loopback Cable Wire Assembly
CMR11-02		Host LDM Communication Add-on Option for each additional communication port
	M8996	Host LDM Modem Module
	2C-HY38A-06	CMR LDM Communication Cable
	2C-HY31A-00 2C-HY33A-00	EIA Berg Port Loopback Test Connector LDM Loopback Cable Wire Assembly

Table 2-2 CMR01 Components List

Option	Parts List	Description
		CMR01 Basic Components The basic CMR01 without any I/O modules is the foundation for building custom configurations. It is not an orderable item.
	2C-E250A-00	CMR01 Remote Box Chassis Assembly with associated hardware
	M8991	Microprocessor Controller #1 Module
	M8992	Microprocessor Controller #2 Module
	M8995	LDM Modem Module
	M9153	Remote Connector Module
	2C-F250A-00	Display Panel Assembly
	MP-D1290-00	Engineering Print Set for CMR01
	Y1-C318C-00	Option Description Manual
	2C-31Y21A-00	EIA Berg Port Loopback Test Connector
	2C-11Y53A-00	LDM Loopback Cable Wire Assembly
CMR01-AA	Basic CMR01 2C-E250A-01	See Description Above AC Power Supply (115/230 Vac)
	17-00081-07	AC Power Cord for 115 Vac Application
CMR01-AB	Basic CMR01 2C-E250A-01	See Description Above AC Power Supply (115/230 Vac)
	17-00082-08	AC Power Cord for 230 Vac Application
CMR01-AC	Basic CMR01 2C-E250A-E2	See Description Above AC/DC Power Supply (115/230 Vac) without DC battery back-up capabilities
	17-00083-07	AC Power Cord for 115 Vac Application
CMR01-AD	Basic CMR01 2C-E250A-07	See Description Above AC/DC Power Supply (115/230 Vac) without DC battery back-up capabilities
	17-00084-08	AC Power Cord for 230 Vac Application

12. BOARD CONFIGURATIONS

2.4 I/O CONTROL MODULES/TERMINATORS

A wide variety of I/O control modules are optionally available with the CMR01 remote unit. These modules are selected by the customer to perform specific operations. Each I/O module must be equipped with a paddleboard cable terminator.

Module summary:

- I/O module
 - Mounts in R-BUS slots.
 - Contains built-in ID code.
 - Terminated by either M9050 or M9052 paddleboard (see Table 2-3).
 - Available in functional varieties.
- I/O paddleboard terminator

Predrilled for customized configuration.

Mounts in slot below the assigned I/O module.

Table 2-3 lists each of the optional I/O modules in addition to the ID code and associated paddleboard cable terminator.

2.5 CMR11/CMV11 POWER/BUS LOADING

Tables 2-4 through 2-6 list all of the module power requirements for the CMR11/CMV11 host, the CMR01 standard components, and the CMR01 optional I/O control configuration.

Table 2-3 (Optional I/O Module List)

Module	Module ID	Termination**	Description
A1001*	12017	M9050	84 Channel Analog Multiplexer, Dry Reed Relay, 2 wire
A1005*	12017	M9050	5-Channel Analog Multiplexer, Dry Reed Relay, 2 wire
A4005	031093	M9050	2-Channel Analog Output Module
M8986	004433	M9050 or M9052	16-Bit Digital Output Module, Mercury Wetted Reed Relay, Form B
M8987	004421	M9050 or M9052	16-Bit Digital Output Module, Reed Relay, Form A
M8994	004424	M9050 or M9052	16-Bit Digital Output Module, Mercury Wetted Reed Relay, Form A
M8993	104481	M9050 or M9052	16-Bit Digitally Coupled Input Module
M8997	101779	M9050 or M9052	4-Channel Optically Coupled Pulse Counter Module

*A805 Analog-to-Digital Converter (uses with A1004 or A1005 and occupies a dedicated slot)
 **M9050 Attaches 16, 2-wire channels with split lug solder connectors

**M9052 Attaches a 40 pin standard Berg connector cable

Table 2-4 CMR/CMV11 Module Input Voltage Chart

Module(s)	Voltage Rating (Approximate Values)	Maximum Voltage	Minimum Voltage	Test Point	Bus Loading
CMR-11 M8990	+5 Volts @ 5.0 A	+5.25	+5.00	Backplane AA2**	POP-11, 1 DC Load, 4 AC Loads
CMV-11 M7181 & M7182 M8996*	-5 Volts @ 5.0 A +5 Volts @ 1.0 A	+5.25 +5.00	+5.00 +5.00	Backplane AA2** J2-E, J2-F	1.58-F1, 1 DC Load, 3 AC Loads N/A

* DC Power for the M8996 (up to four) is supplied by the host controller via cable 2C-DY18A. Add 1.0 A for each M8996.

** (Ground Pin is AC2)

NOTE

Do Not Exceed Normal Bus Loading:

- 20 DC Loads without bus repeater.
- 20 AC Loads (Q-BUS) without terminated backplane.
- 35 AC Loads (Q-BUS) with terminated backplane.
- Maximum UNIBUS cable without bus repeater — 15.25 m (50 feet).

Table 2-5 CMR01 Remote Unit Voltage Chart

Unit	Voltage	Test Points
CMR01 without I/O Modules	12Vdc @ 1.7 A	CMR01 Backplane Pins AA1, AA2
Includes M8951, M8991, M8992, M8993 and display panel.		Ground Pins AC1, AC2

2.6 CONFIGURATION VARIABLES

This section provides the information needed to implement a wide variety of CMR11/CMV11 system configuration variables. These include device placement, device/vector addressing, port baud rate selection, remote ID addressing, and modem related variables. Section 2.6.1 provides CMR11/CMV11 host requirements while Section 2.6.2 outlines the CMR01 remote unit requirements.

2.6.1 CMR11/CMV11 Host Considerations

- Mounting

CMR11, one low-height small peripheral controller (SPC) backplane slot.

CMV11, three double-height SPC backplane slots: one for M7181 and two for piggybacked M7182.

- Device Placement

Units not require any particular placement on the bus. For CMV11, Q-BUS interrupt priority rules apply. Because the M7182 does not pass on Q-BUS interrupt grant signals, the M7182 must be the last device on the Q-BUS.

- Device Address

Assigned to user-address area beginning at 764070. For switchpack location and address selection refer to Figure 2-1 for CMR11 or 2-3 for CMV11.

- Vector Address

Assigned to user-address area beginning at 170. For switchpack location and address selection refer to Figure 2-2 for CMR11 or 2-4 for CMV11.

Table 2-6 CMR01 Optional Module Voltage Chart

Module (s)	Voltage Rating DC	Maximum Voltage	Minimum Voltage	Test Point
A1004	+12 Volts @ 0.3 A	+17.0 Vdc	-9.0 Vdc	CMR01 Backplane pins A41, A42
A1005	+12 Volts @ 0.3 A	+17.0 Vdc	+9.0 Vdc	
A805	+12 Volts @ 0.9 A	+17.0 Vdc	+9.0 Vdc	Ground Pins are AC1, AC2
A6005	+12 Volts @ 0.9 A	+17.0 Vdc	+9.0 Vdc	
MR996	+12 Volts @ 0.4 A	+17.0 Vdc	+9.0 Vdc	
MR997	+12 Volts @ 0.4 A	+17.0 Vdc	+9.0 Vdc	
MR998	+12 Volts @ 0.2 A	+17.0 Vdc	+9.0 Vdc	
MR994	+12 Volts @ 0.4 A	+17.0 Vdc	+9.0 Vdc	
MR993	+12 Volts @ 0.4 A	+17.0 Vdc	+9.0 Vdc	
MR992	+12 Volts @ 0.4 A	+17.0 Vdc	+9.0 Vdc	

- Interrupt Priority

Normally BR4. For location, refer to Figure 2-1 for CMR11 or Figure 2-3 for CMV11.

- Baud Rate Selection

Switches are provided to select the host baud rate for each port. Refer to Figure 2-1 for CMR11 and Figures 2-4 and 2-5 for CMV11 selections.

- Host LDM (M8996) Modem Variables

Five switches on the M8996 must be correctly positioned to select certain conditions. See Figure 2-6 for switch function and placement.

NOTE

The remote LDM (M8995) is very similar to the M8996. Switch locations on both modules are identical.

2.6.2 CMR01 Remote Unit Considerations

- Port Selection

Switch S1 on the M9053 module must be placed in the correct position to select the host port number to which this remote is connected. See Figure 2-7 for details.

- Baud Rate Selection

Switch S2 on the M9053 module must be placed in the correct position to select the baud rate at which the line will operate. See Figure 2-7 for details.

- Remote ID Address

Each remote unit requires a unique three-digit address. The first digit is the port number selected above. The last two digits are set up by switches S3 and S4 on the M9053. Addresses are in octal. See Figure 2-7 for details.

- Remote LDM (M8995) Modem Variables

Five switches on the M8995 module must be correctly positioned to select certain conditions. The M8995 is very similar to the host M8996. Switch locations and functions are identical. Refer to Figure 2-6.

18 BOARD CONFIGURATIONS

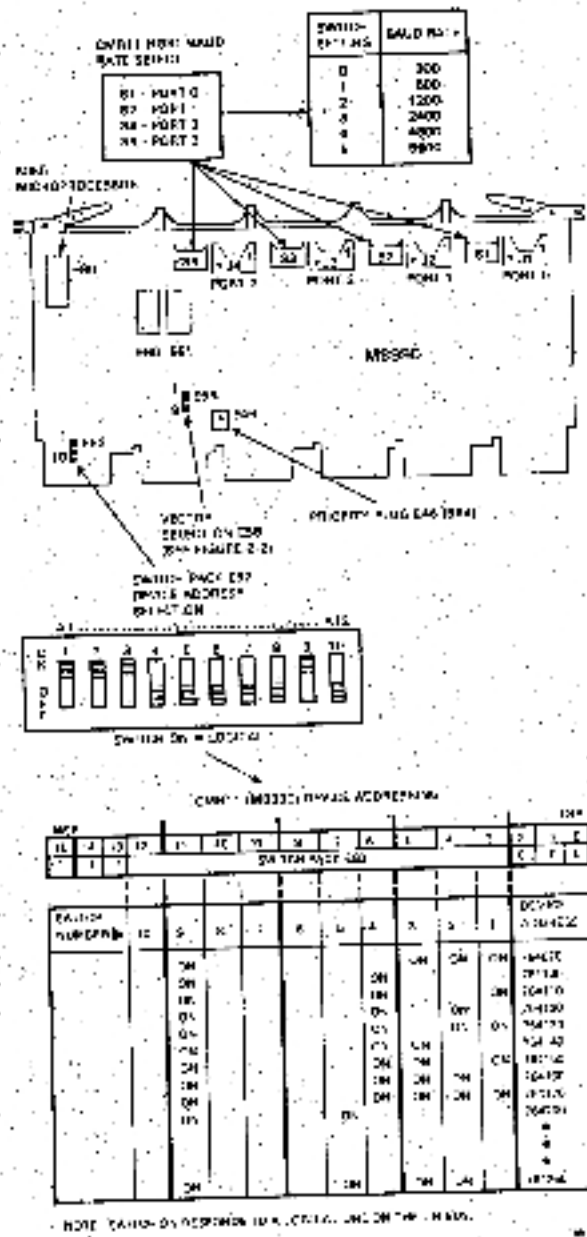

Figure 2-1: CMR21 (M8990) Device Address/Host Baud Rate Selection

BOARD CONFIGURATIONS 19

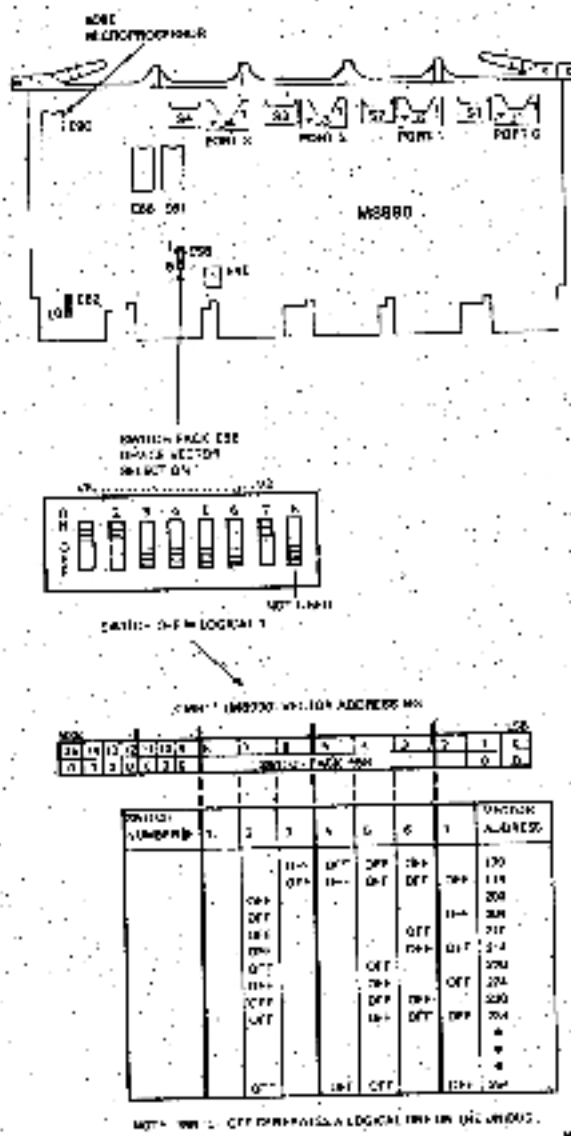

Figure 2-2 CMR II (MR900) Vector Address Selection

20 BOARD CONFIGURATIONS

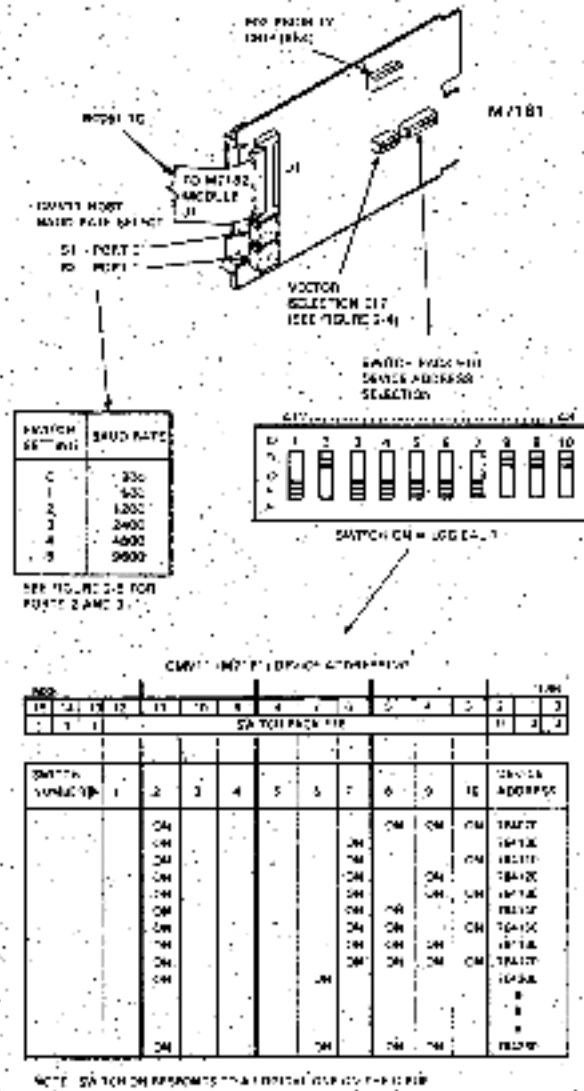

Figure 2-3 CMV11 (M7181) Device Address/Host Baud Rate Selection (Ports 0-3)

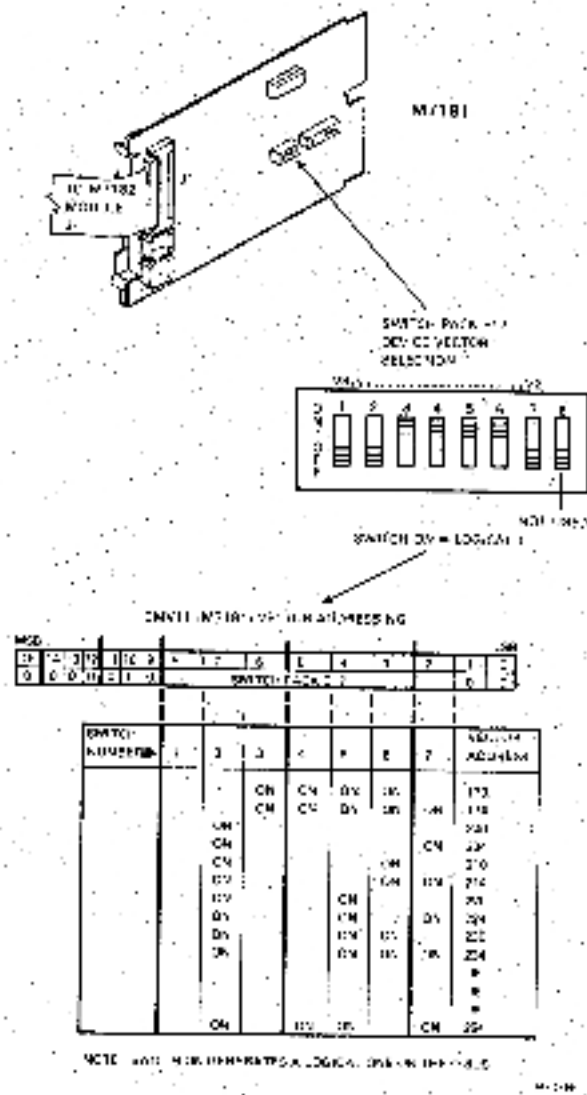

Figure 2-4 CMV11 (M7181) Vector Address Selection

22 BOARD CONFIGURATIONS

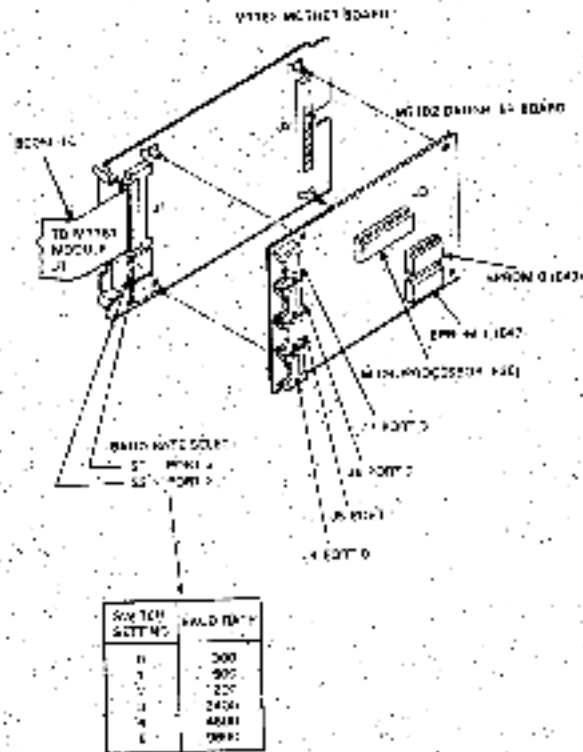

Figure 2-5 CMV11 Host Baud Rate Selection
(Parts 2-3)

BOARD CONFIGURATIONS 23

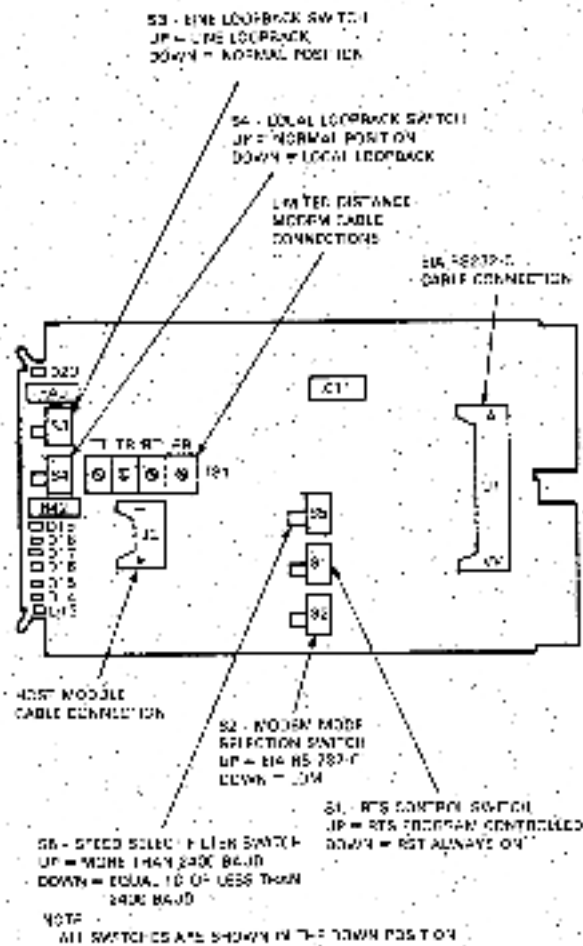

Figure 2-6 HWF LDM (M8996) Modem Variables

24 BOARD CONFIGURATIONS

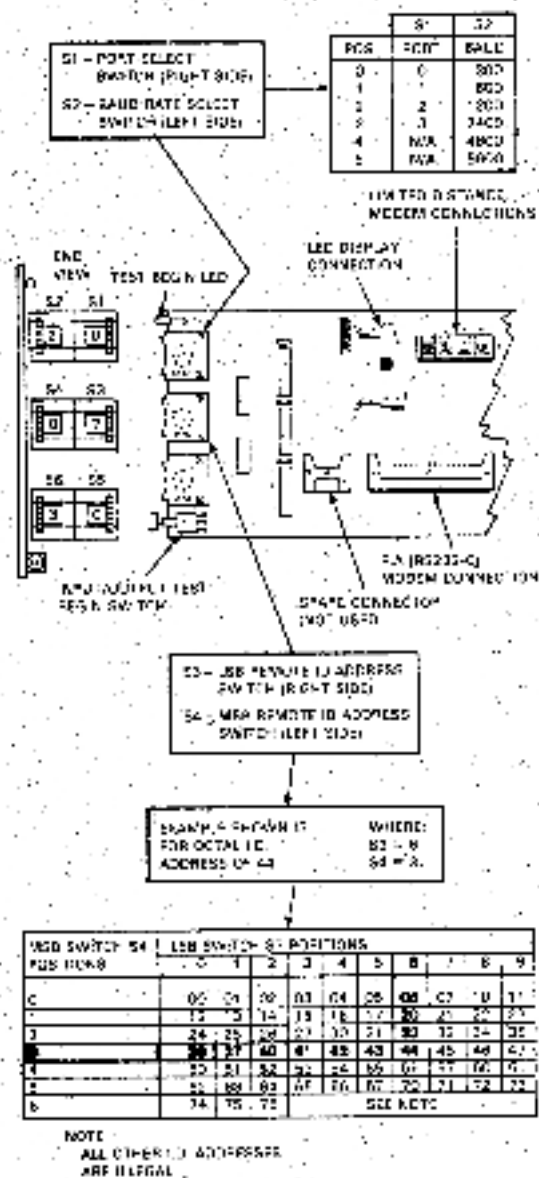

Figure 2-7 Remote (M9053) Configuration Variables

2.7 INSTALLATION CHECKOUT

A number of steps are provided in the installation procedure to verify that the preinstallation considerations have been determined and correctly implemented.

The installation process involves two procedures:

1. Installing the CMR11/CMV11 host controller, and
2. The CRM01 remote unit.

Refer to the installation flowcharts of Figures 2-8 and 2-9 to verify that the CMR11/CMV11 is correctly installed.

2.8 CABLING AND TEST CONNECTORS

Two cabling configurations (shown in Figure 2-10) are possible: EIA and LDM. Outline drawings of each cable are provided in Figure 2-11.

Tandem test connector placement is also shown in Figure 2-10, while Figure 2-12 provides a drawing and signal flow for each test connector.

Cable summary (See Figure 2-11):

- **BC05L-1C**
A 78 cm (15 in), 40-conductor cable that connects M7181 to M7182 (CMV11 only).
- **2C-HY38A-06**
A 1.8 m (6 feet), 10-conductor cable that connects host controller to host LDM (MS996).
- **BC05C-XA**
Cable length variable up to 15.25 m (50 feet) maximum. Connects host LDMs (MS996) to EIA systems.
- **LDM Cable**
Customer supplied 4-wire cable similar to standard telephone cable.

Test connector summary (See Figure 2-12):

- 2C-11Y50A - Host port loopback
- 2C-11Y51A - EIA berg loopback
- 2C-11Y53A - LDM (TS1) loopback
- H325 - EIA cable loopback

28 BOARD CONFIGURATIONS

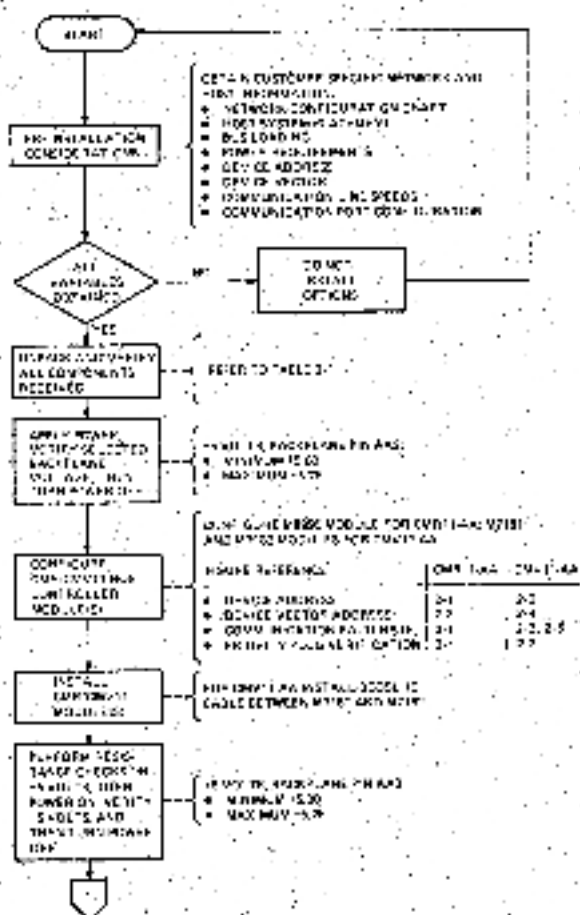

Figure 2-8 CMR11/CMV11 Installation Flowchart (Sheet 1 of 3)

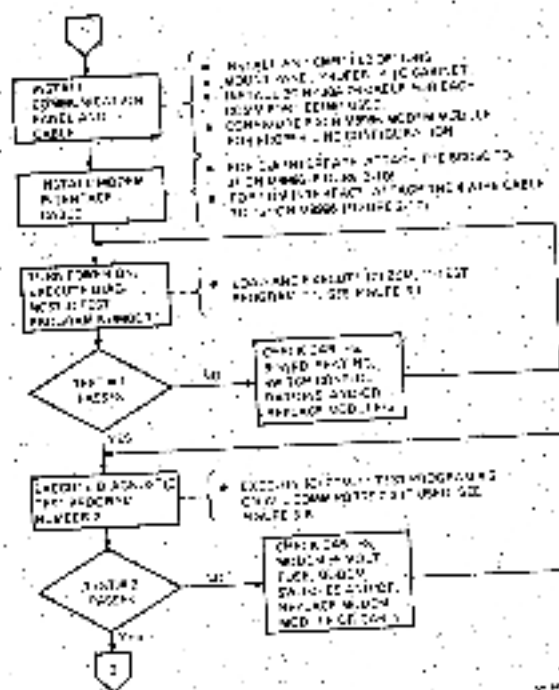

Figure 2-B. CMR11/CMV11 Installation Flowchart (Sheet 2 of 3)

2B BOARD CONFIGURATIONS

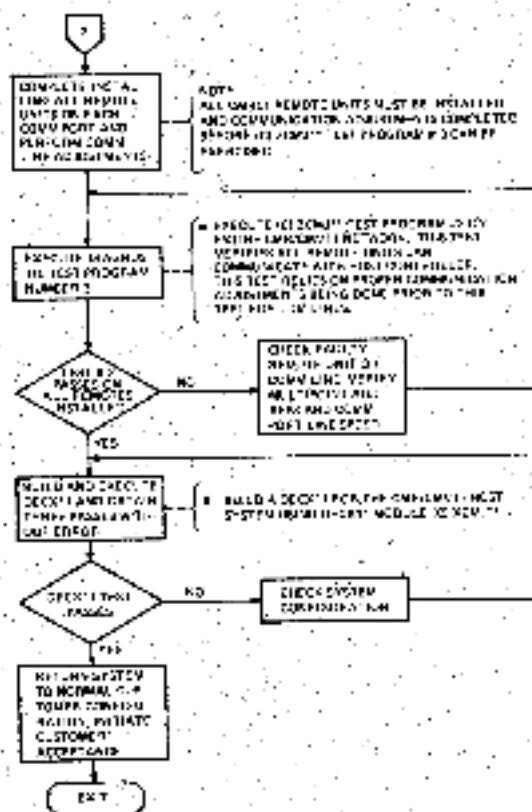

Figure 2-8 CMR11/CMV11 Installation Flowchart (Sheet 3 of 3)

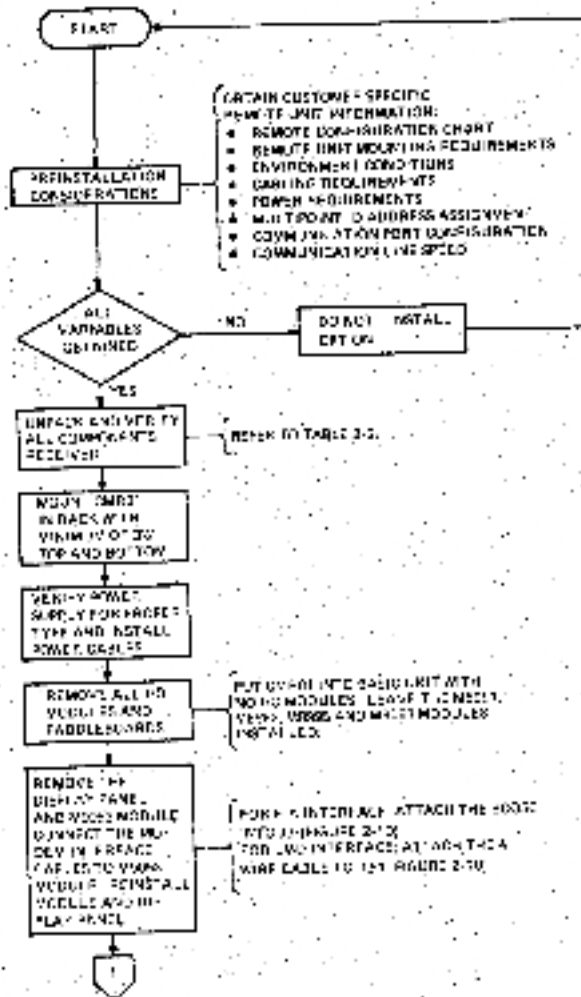

Figure 3-9 CMR01 Installation Flowchart (Sheet 1 of 2)

30 BOARD CONFIGURATIONS

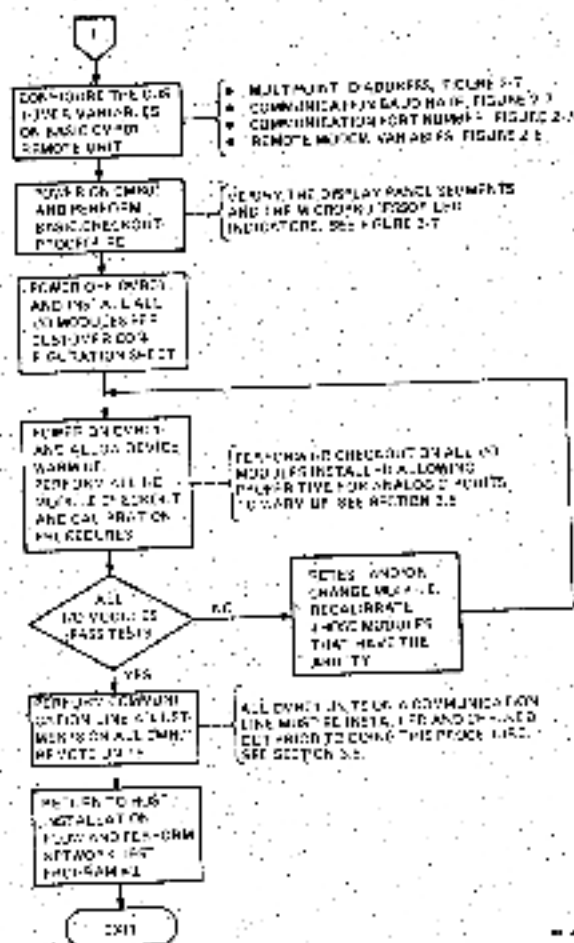

Figure 2-9- CMR01 Installation Flowchart (Sheet 2 of 2)

32 BOARD CONFIGURATIONS

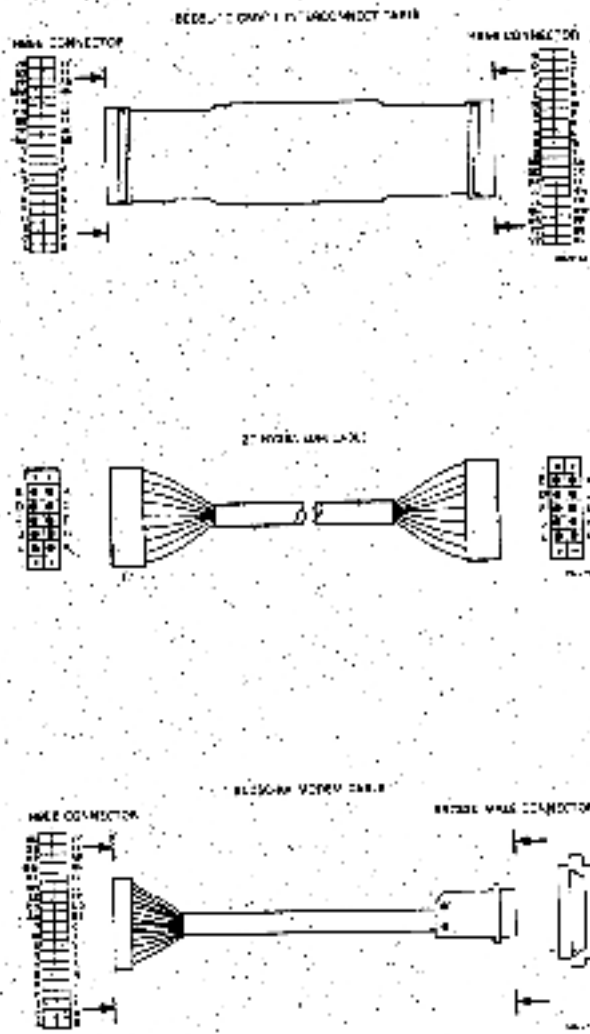

Figure 2-11 CMR11/CMV11 Cables

34 BOARD CONFIGURATIONS

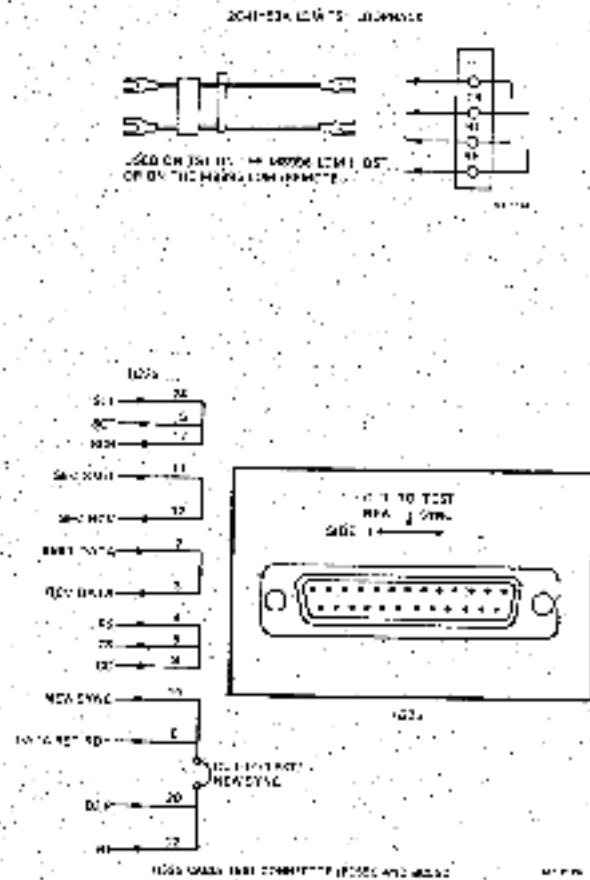

Figure 2-12 CMR11/CMV11 Test Connectors
(Sheet 2 of 2)

3 TEST AND CALIBRATION

3.1. INTRODUCTION

This chapter provides all the information necessary to troubleshoot and maintain the CMR11/CMV11 system.

Because of the complexity of the CMR11/CMV11, and because the network configuration includes remote sites spread over a large geographic area, the system is difficult to adjust and maintain. The traditional symptom/possible cause approach to troubleshooting is next to impossible to generate for the CMR11. As an alternative, checkout and calibration procedures are provided in flowchart format.

The CMR11 is supported by many different testing capabilities from local device testing using internally stored microdiagnostics, to a complete network exerciser diagnostic program.

Maintenance procedures for the CMR11/CMV11 host controller utilize the (C)ZCMJ diagnostic program. The program provides three major subsystems:

CMR11 procedures use internal microdiagnostics and a special maintenance panel to check out the basic remote unit and a special test kit (CMR01-TA) to perform I/O controller checkout.

3.2. DIAGNOSTIC SUMMARY

DIAGNOSTIC NAME:
CMR11/CMV11 FUNCTIONAL DIAGNOSTIC

DESIGNATION:
(C)ZCMJ

36 TEST AND CALIBRATION

ORDER NUMBER:

AK-F913* -M1;
BINARY TAPE

AH-F914* -MC;
LISTING (FICHE)

AH-F912* -M1;
LISTING (HARD COPY)

CONTROL CHARACTERS

CTRL-C Exit test program
CTRL-T Exit test program
CTRL-G Show software switch register values
CTRL-O Enter maintenance debug routine
CTRL-F Show console fill count
CTRL-A Print port configuration table
P Proceed

CAUTION

Before executing any diagnostics, be sure that the functions being controlled by this device (customer's process) are terminated and the I/O cable modules removed.

SWITCH REGISTER OPTIONS

Bit 15 (100000)	Do not halt on errors
Bit 14 (040000)	Do not print errors
Bit 13 (020000)	Loop on erroneous routine
Bit 11 (004000)	Inhibit program iterations
Bit 10 (002000)	Do not print end of pass

TESTS

Sub Test 1	Logic test
Sub Test 2	Port loopback
Sub Test 3	CMR exercise

EXECUTION TIME

Sub Test 1	1 minute
Sub Test 2	Depends on line speed (up to 10 seconds at 300 baud)
Sub Test 3	Depends on line speed (up to 30 minutes at 300 baud)

*R/W level

3.3 TEST DESCRIPTIONS

The (C)ZCMJ diagnostic program is started at address 200 and includes the following four hardware prompts that must be answered by operator interaction. Each entry must be followed by a <CR>. Entering only <CR> causes default values to be used.

Prompt	Default Values
Device address	764070
Vector address	170
Device priority	4
Select test	1

3.3.1 Sub-Test 1

This test is a basic CMR11/CMV11 host-controller logic test. It verifies all device registers, scratch pad memory, interrupt logic, and simple I/O functions. This test also reads hand line switches and prints results. Figure 3-1 is a sample printout.

```

SELECT TEST (4=HELP) 1
LOGIC TEST
HOST FIRMWARE VERSION : 001.02 9-JUL-91
BASE RATE#1
PORT #0 = 9400
PORT #1 = 9400
PORT #2 = 9400
PORT #3 = 9400
END PASS #1 ERR CNT = 0
END PASS #2 ERR CNT = 0
END PASS #4 ERR CNT = 0
END PASS #6 ERR CNT = 0
SELECT TEST (4=HELP)

```

Figure 3-1 (C)ZCMJ Test-1 Sample Printout

3.3.2 Sub-Test 2

This test is a communication loopback test used to troubleshoot line problems and to provide the means to make EDM adjustments. Several methods are available to achieve loopback. This depends on the interface and loopback connector type.

Loopback variations:

- Local loopback switch. Place S4 on M8996 EDM to LOCAL LOOPBACK position.

38 TEST AND CALIBRATION

- Host port loopback – Attach 2C-HY50A-00 test connector to each M8990 port (J1-J4).
- EIA berg loopback – Attach 2C-HY51A-00 test connector to M8996 EIA berg port (11).
- EIA cable loopback – Attach 11325 test connector to the end of the BC05C-XX cable.
- LDM loopback – Place 2C-HY53A-00 test connector to M8995 terminal strip TTS11. Connect TT to RT (lug 1 to lug 3) and ER to RR (lug 2 to lug 4).
- Place S3 on remote M8995 to line loopback position.

Figure 3-2 is a sample printout of Test 2. Notice that one additional prompt is required.

```
SELECT TEST (4-Help) 2
PAGE 1000-DACK TEST
TYPE PAGE 4 (CR=ALL) 9
TYPE (CR) WHEN READY:
END PASS #1 ERR. CNT = 0 EL. TIM.=01011200
END PASS #2 ERR. CNT = 0 EL. TIM.=01011204
END PASS #3 ERR. CNT = 0 EL. TIM.=01011208
END PASS #4 JMW. CNT = 0 EL. TIM.=01011212
END PASS #5 ERR. CNT = 0 EL. TIM.=01011216
END PASS #6 ERR. CNT = 0 EL. TIM.=01011220
END PASS #7 ERR. CNT = 0 EL. TIM.=01011224
END PASS #8 ERR. CNT = 0 EL. TIM.=01011228
END PASS #9 ERR. CNT = 0 EL. TIM.=01011232
END PASS #10 ERR. CNT = 0 EL. TIM.=01011236
END PASS #11 ERR. CNT = 0 EL. TIM.=01011240
END PASS #12 ERR. CNT = 0 EL. TIM.=01011244
END PASS #13 ERR. CNT = 0 EL. TIM.=01011248
SELECT TEST (4-HELP)
```

Figure 3-2 (C)ZCMJ Test 2 Sample Printout

3.3.3 Sub-Test 3

This test is a network exerciser that scans the entire network and reports on all remote units. The report includes the ID numbers of all attached remotes and status changes or errors. Execution time could take as long as 30 minutes depending on the line speed. Loopback connector/switches are not required for this test. Figure 3-3

TEST AND CALIBRATION 33

is a sample printout without any changes, while Figure 3-4 indicates a status change; remote unit ID 14 is activated.

```

SELECT TEST (A-HELP) 3
CHR EXERCISE ROUTINE
(GIVE ME A FEW MINUTES ALONE WITH THE REMDIES:
** PORT CONFIGURATION **
PORT #0      6000      3700      7100
END PASS #1  ERR. CNT = 0 EL. TIM.=012:13:44
END PASS #2  ERR. CNT = 0 EL. TIM.=012:20:55
END PASS #3  ERR. CNT = 0 EL. TIM.=012:28:17
END PASS #4  ERR. CNT = 0 EL. TIM.=012:35:23
END PASS #5  ERR. CNT = 0 EL. TIM.=012:42:13
END PASS #6  ERR. CNT = 0 EL. TIM.=012:50:28
END PASS #7  ERR. CNT = 0 EL. TIM.=012:57:40
END PASS #8  ERR. CNT = 0 EL. TIM.=012:57:40
END PASS #9  ERR. CNT = 0 EL. TIM.=013:12:32
END PASS #10 ERR. CNT = 0 EL. TIM.=013:19:44
END PASS #11 ERR. CNT = 0 EL. TIM.=013:27:14
END PASS #12 ERR. CNT = 0 EL. TIM.=013:34:46
END PASS #13 ERR. CNT = 0 EL. TIM.=013:41:40
END PASS #14 ERR. CNT = 0 EL. TIM.=013:49:27
END PASS #15 ERR. CNT = 0 EL. TIM.=013:56:27

```

Figure 3-3 (C)ZCMI Test 3 Sample Printout (No Status Changes)

```

SELECT TEST (A-HELP) 3
CHR EXERCISE ROUTINE
(GIVE ME A FEW MINUTES ALONE WITH THE REMDIES:
** PORT CONFIGURATION **
PORT #0      3700      7100
*** REMOTE STATUS CHANGE ***
REMOTE #14
REMOTE STATUS NOW REQUIRING
END PASS #1  ERR. CNT = 0 EL. TIM.=012:11:03
END PASS #2  ERR. CNT = 0 EL. TIM.=012:19:13
** PORT CONFIGURATION **
PORT #0      1400      3700      7100
END PASS #3  ERR. CNT = 0 EL. TIM.=012:27:06
END PASS #4  ERR. CNT = 0 EL. TIM.=012:35:12
END PASS #5  ERR. CNT = 0 EL. TIM.=012:43:22
END PASS #6  ERR. CNT = 0 EL. TIM.=012:51:32

```

Figure 3-4 (C)ZCMI Test 3 Sample Printout (with Status Changes)

40 TEST AND CALIBRATION

3.4 CMR11/CMV11 HOST CONTROLLER CHECKOUT

Checkout procedures for the CMR11/CMV11 host controller requires executing (C)ZCMJ diagnostics. The flowchart of Figure 3-5 illustrates the CMR11/CMV11 checkout procedures. Test programs #1 and #2 can be executed on a partially installed system. Test program #3, however, requires that the complete system be installed and properly connected. Test program #3 further requires that the communications line adjustments be made before executing the test.

3.5 CMR01 REMOTE CHECKOUT PROCEDURES

The CMR01 remote unit checkout procedures are performed in three steps. The first step provides a simple checkout of the basic CMR01 without testing any of the I/O modules. The second step tests each of the I/O modules and provides for calibrating two modules; the A805 and the A6005. The final step is to perform communications line adjustments to ensure proper communication between host and remote.

These three procedures must be performed in the order they were explained. All three procedures use the maintenance display panel located on the lower-left front of the remote chassis. The maintenance panel is summarized in the following section.

3.5.1 Maintenance Display Panel

The maintenance panel, shown in Figure 3-6, contains a variety of switches and a six-digit LED display to implement test functions associated with the three CMR01 checkout procedures. Some switches perform dual functions. Table 3-1 lists all of the possible error codes that may appear in the LED display.

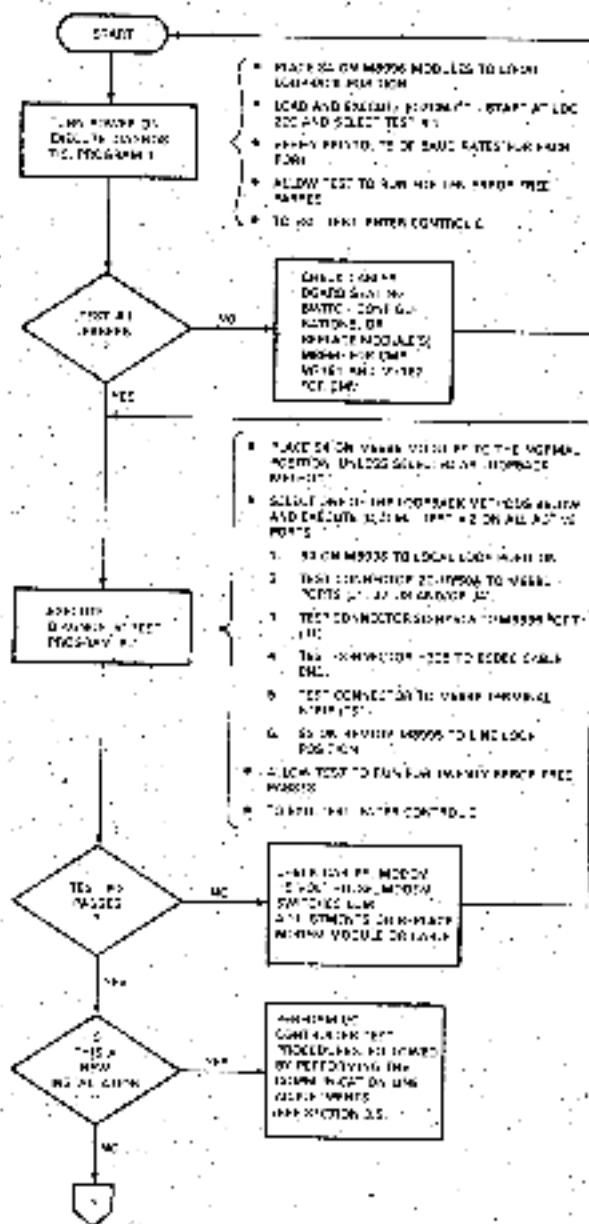

Figure 3-5 CMR 11/CMV 11 Checkout Procedures (Sheet 1 of 2)

42 TEST AND CALIBRATION

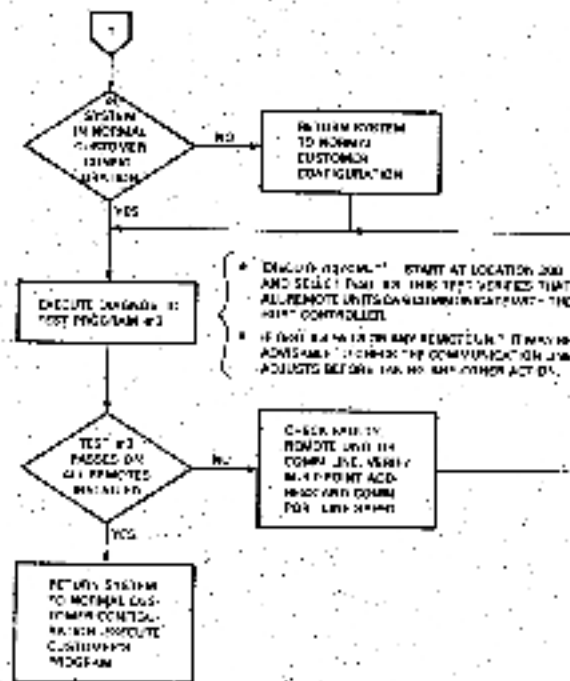
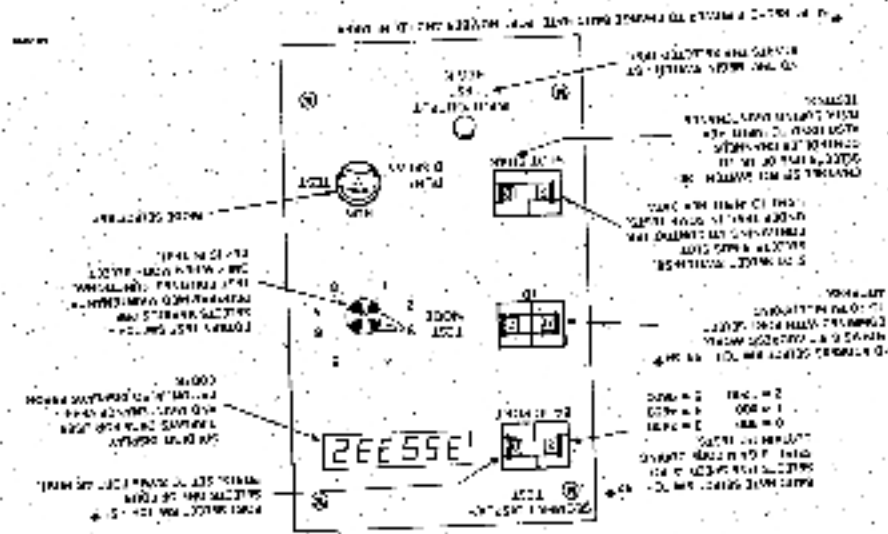

Figure 3-5 CMR11/CMV11 Checkout Procedures
(Sheet 2 of 2)

Figure 3-6 C-1801 Maintenance/Display Panel



44 TEST AND CALIBRATION

Table 3-1 CMR11 Error Codes

Code	Meaning
1	Function or Request Successful
2	Broadcasted Message Was Sent Out Successfully
GENERAL REMOTE ERRORS	
200	No module installed in slot specified
201	Channel requested is not contained in module
202	Module type is not correct for slot specified
203	Module does not respond, was there on power up
205	Too many read registers or Read All Function
206	No store data to return for a Return Broadcast
REMOTE ERRORS ON ADD ALARM ENTRY FUNCTION	
220	Channel not added to alarm table, table full
221	Alarm table empty, no control possible
222	Counts not the same for both HI/LO parameters
223	Alarm type not available in the remote
224	Module type not suitable for alarm type spec'd
ANALOG CONVERSION ERROR	
230	Multiplexer - Hard error
231	Time out on analog conversion
FIRMWARE DIAGNOSTIC ERRORS ONLY AT REMOTE DISPLAY	
240	Input module error on Defined Output Test
241	Data Set Ready not set for Remote Loopback Test
242	Time out on Remote Loopback Test
REMOTE WARNINGS	
250	Warning: Function not necessary in remote
251	Warning: Alarm Channel Overwritten
252	Warning: Output Channel Specified for Alarm Table
REMOTE ERRORS WHICH INDICATE FUNCTION WAS ABORTED	
260	Subj Function not implemented in remote
261	Bad parameters detected at the remote
262	Function could not be executed in present remote state
300	Function could not be executed in host
301	Function not allowed (as spec'd) in host mode
302	Too many requests for this function
303	Bad parameters for this request
304	Invalid mode request
305	Invalid length
310	No Trace data stored
317	No regular remotes on this port
320	Broadcast on interrupt is invalid
321	Broadcast in poll queue is invalid
322	Broadcast on return broadcast/store is invalid

Table 3-1 CMBII Error Codes (Cont)

Code	Meaning
323	No poll queue in mode 1 is illegal
324	Poll queue specified is too large
330	Invalid slot number
332	Invalid Channel number
COMMUNICATION ERRORS	
340	CRC Error on message from remote
341	Timeout on transmission to remote
342	Received a byte count that is too long
343	Received a byte count that is too short
344	Received an erroneous function code
345	Received an erroneous remote ID
346	Wrong function code received on return broadcast
349	Time out on the Transmitter
SUCCESS CODES	
364	Function was executed but some of the requests have errors
360	Function was executed but some of the requests have warnings
372	Latency error on host loopback
373	Receiver timeout on host loopback
374	Transmitter time out on host loopback
375	Illegal request count on maintenance function
376	Illegal port number on host loopback
377	Function failed, refer to USOR

3.5.2 CMR01 Basic Test Procedure

The basic CMR01 test procedure is illustrated in Figure 3-7. The procedure makes many references to various LEDs on each of the modules. Refer to Figure 3-8 for LED identification.

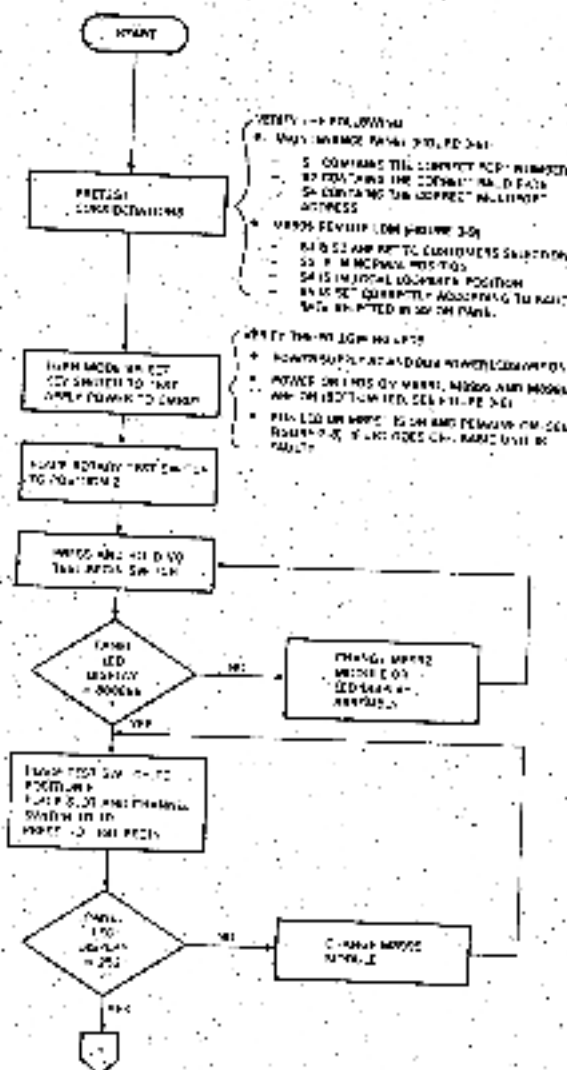

Figure 3-7 Basic CMR01 Test Procedure (Sheet 1 of 2)

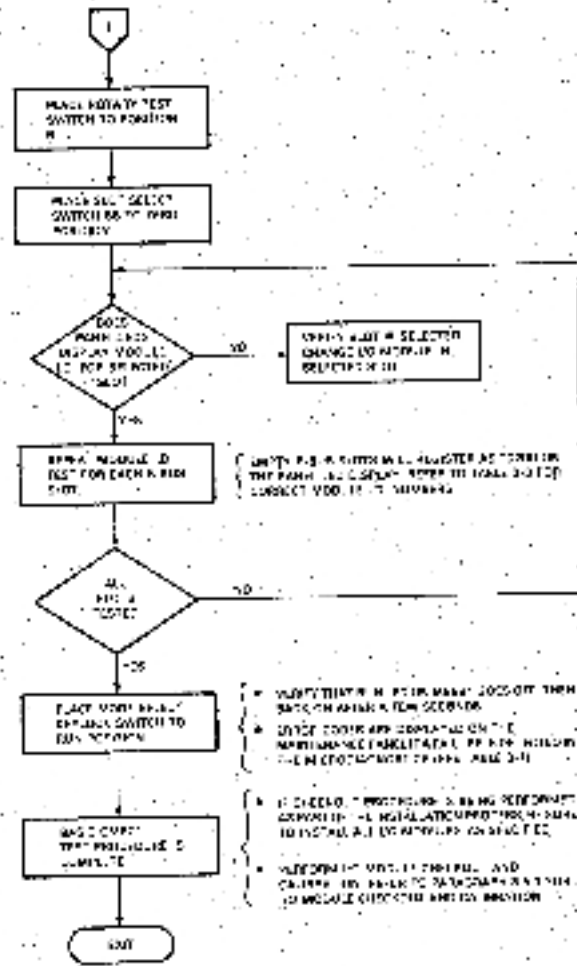

Figure 3-7 Basic CMR01 Test Procedure (Sheet 2 of 2)

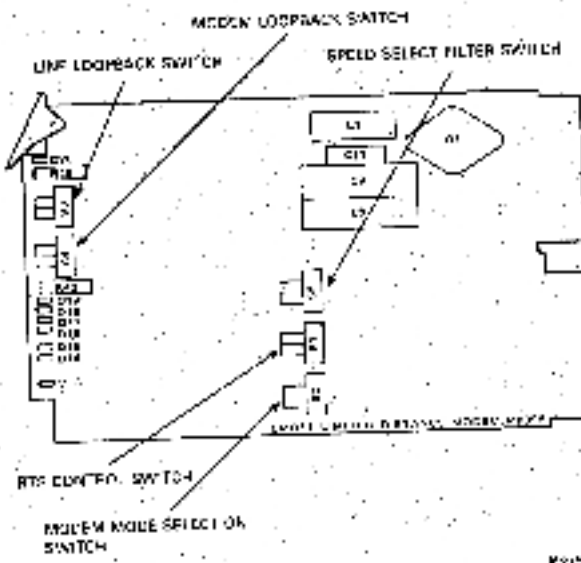

Figure 3-9 M8998 Switch Locations

3.5.3 CMR01 Remote I/O Controller Test Procedure

This procedure is the second part of the three step CMR01 checkout procedure. A special test kit (CMR01-TA), consisting of test modules and interconnecting cable, is required to perform this checkout and calibration procedure. These test modules and associated switches and LEDs are summarized below.

CMR01-TA test kit consists of one each:

- G5153 test module for digital I/O and pulse count testing (see Figure 3-10).
- CMRT1-11 signal conditioning paddleboard for the G5153 (see Figure 3-11).
- BC05B-03 40 conductor flat ribbon cable 0.9 m (3 feet) used to interconnect the G5153 and CMRT1-11 (see Figure 3-12).
- A908 analog I/O test module (see Figure 3-13).

Figure 3-10 COTS3 Digital I/O Pulse Count Test Module

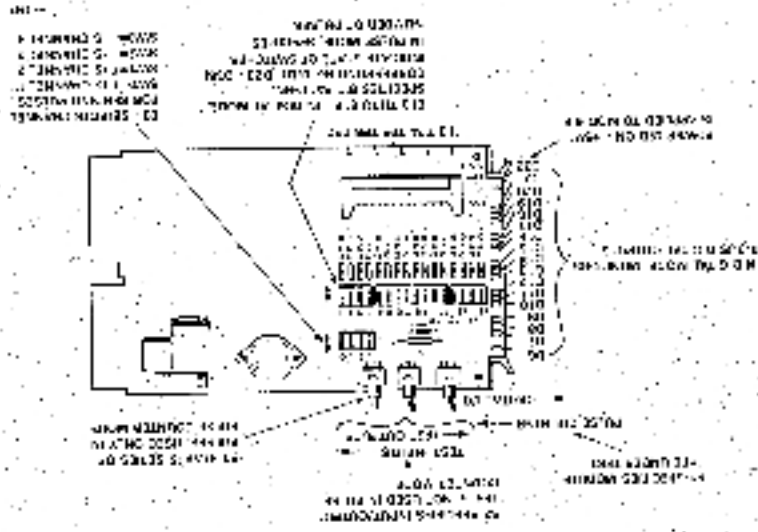

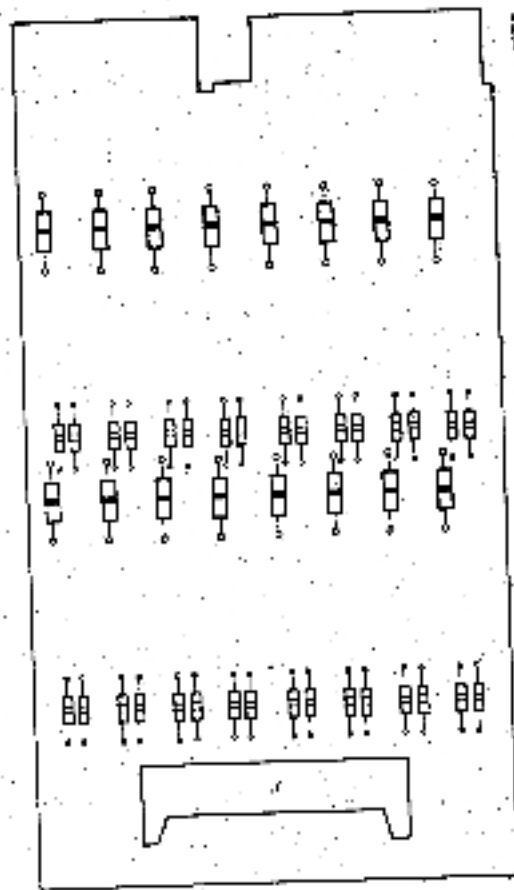

Figure 3-11 C-MRTM-11 Signal Conditioning Paddlebox (M9052)

52 TEST AND CALIBRATION

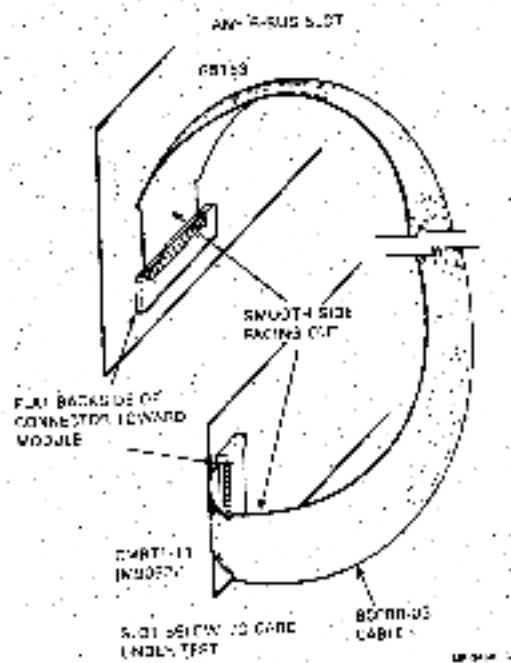

Figure 3-12 BC08R Test Interconnect

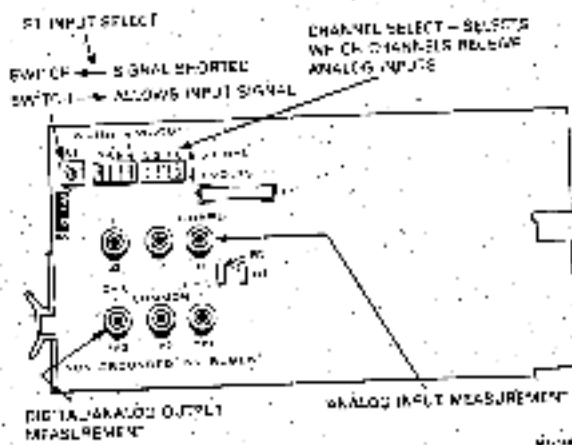

Figure 3-13 A908 Analog I/O Test Module

Figures 3-15, 3-19, and 3-22 through 3-25 outline checkout procedures for the various I/O modules listed below, while Figures 3-16 and 3-20 provide calibration procedures for the A805 and A6005 modules respectively.

Module	Checkout	Calibration
A805	3-15	3-16
A6005	3-19	3-20
A1004 A005	3-22	
M8993	3-23	
M8985 E7 M8994	3-24	
M8997	3-25	

IMPORTANT

- Be sure to allow ample time for modules to warm up and stabilize before testing.
- Test all I/O controllers of the same type before proceeding to the next type.

3.5.3.1. Module A805 Checkout Procedure -

- Test summary
 - Verifies the four gain codes.
 - Verifies automatic gain code conversion.
 - Verifies analog to digital (A/D) conversion for each gain code.
- Equipment required
 - An A1004 or A1005 analog multiplexer input module
 - An A908 analog test module
 - A voltage standard
 - A precision digital voltmeter
- Test configuration
 - See Figure 3-14.

The A805 analog-to-digital converter checkout procedure is presented in Figure 3-15.

54 TEST AND CALIBRATION

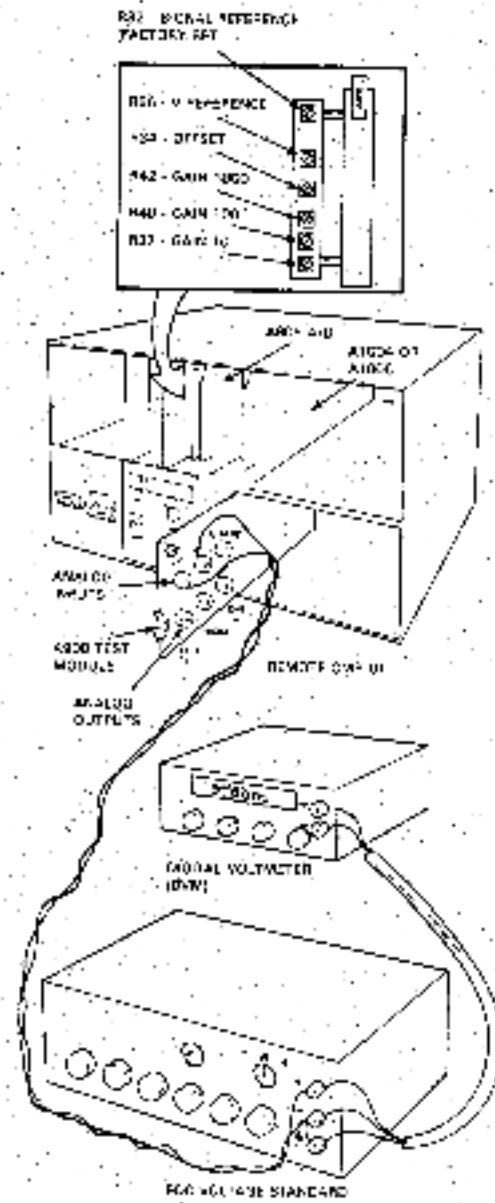

Figure 3-14 A805 Test Configuration

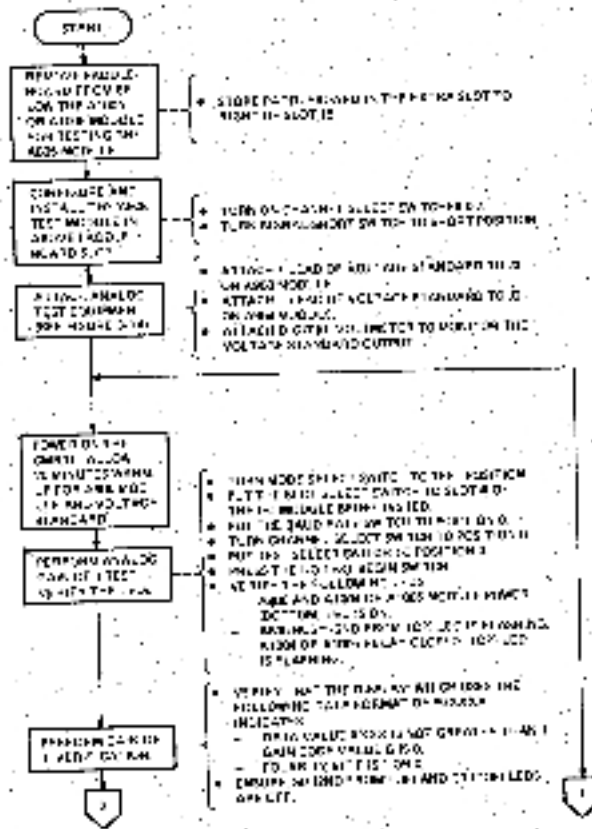

Figure 3-15 A805 Checkout Procedure (Sheet 1 of 4)

56 TEST AND CALIBRATION

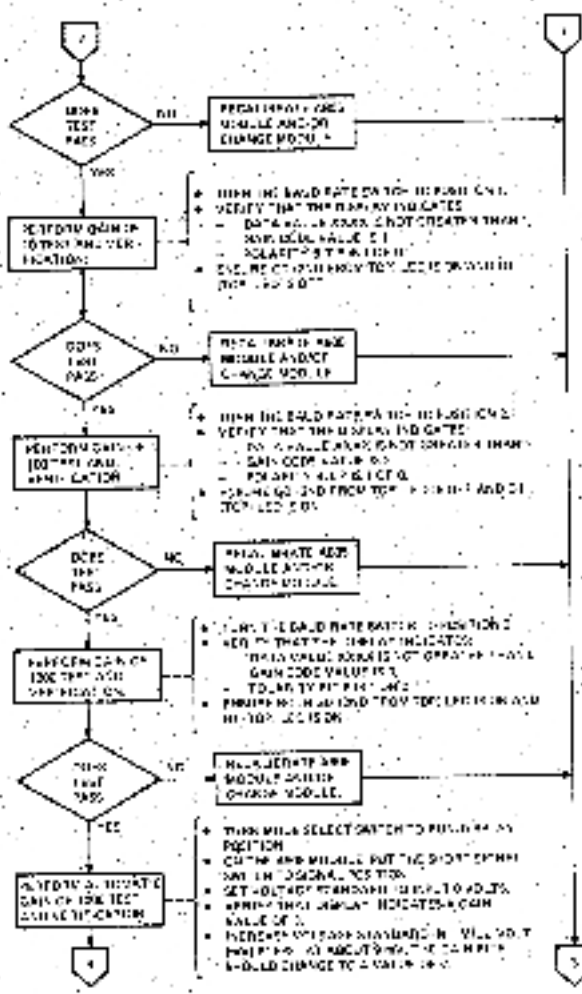

Figure 3-15 A805 Checkout Procedure (Sheet 2 of 4)

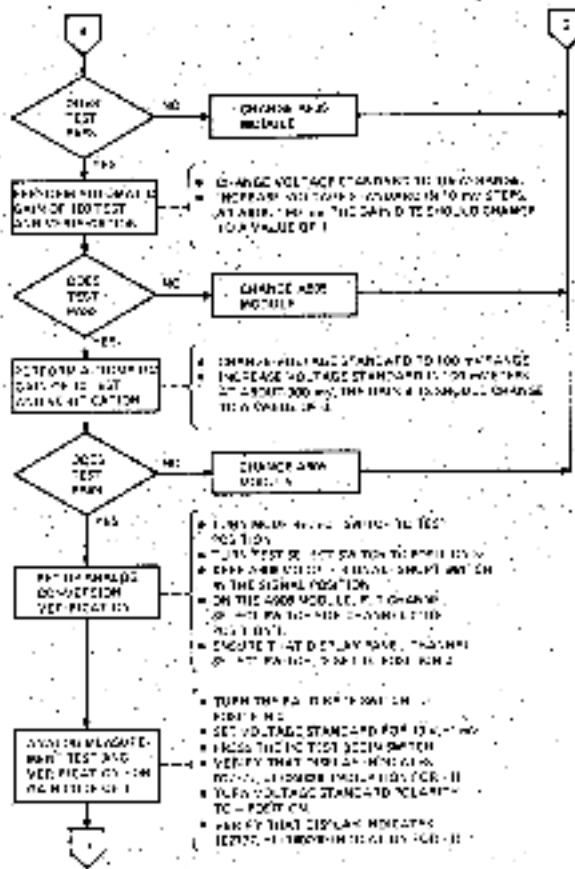

Figure 3-15 A805 Checkout Procedure (Sheet 3 of 4)

58 TEST AND CALIBRATION

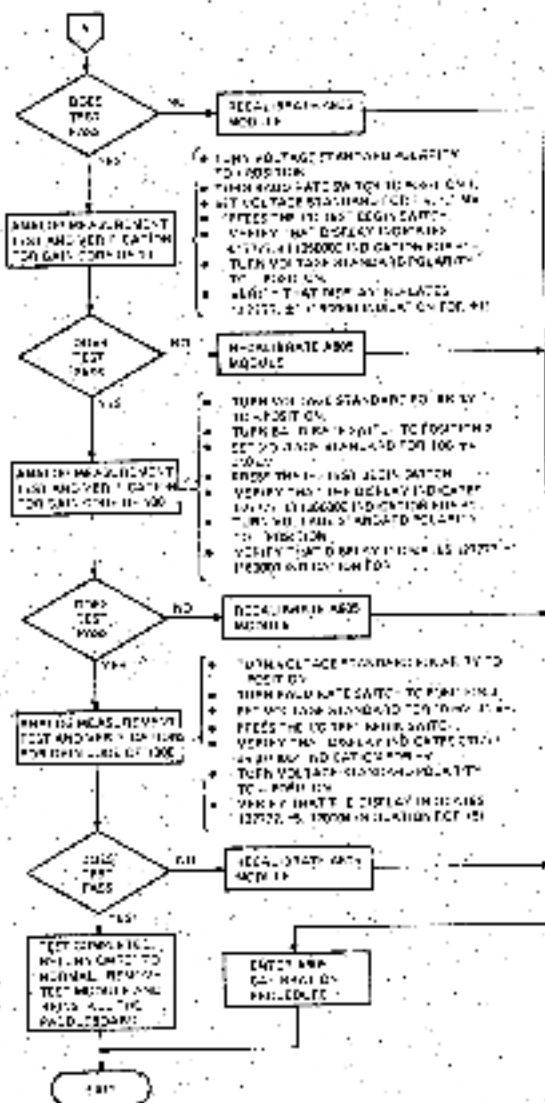

Figure 3-15 A805 Checkout Procedure (Sheet 4 of 4).

60 TEST AND CALIBRATION

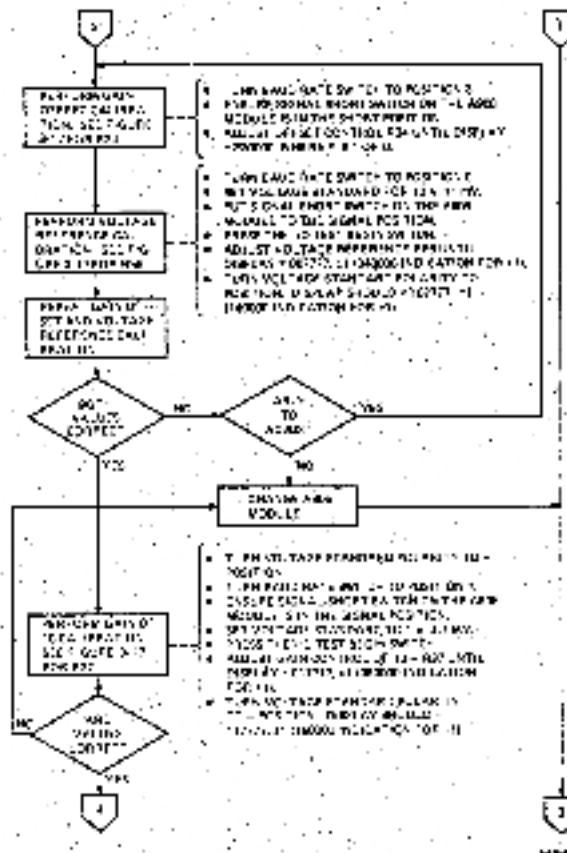

Figure 3-16 ASOS Calibration Procedure (Sheet 2 of 3)

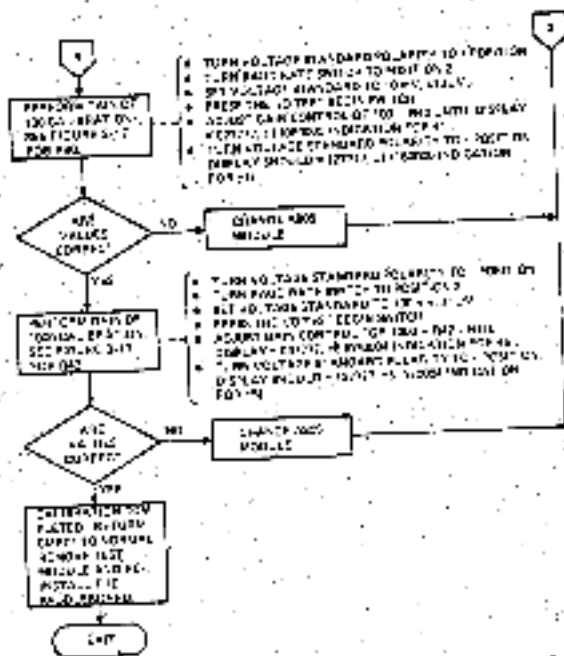

Figure 3-16 A805 Calibration Procedure
(Sheet 3 of 3)

82 TEST AND CALIBRATION

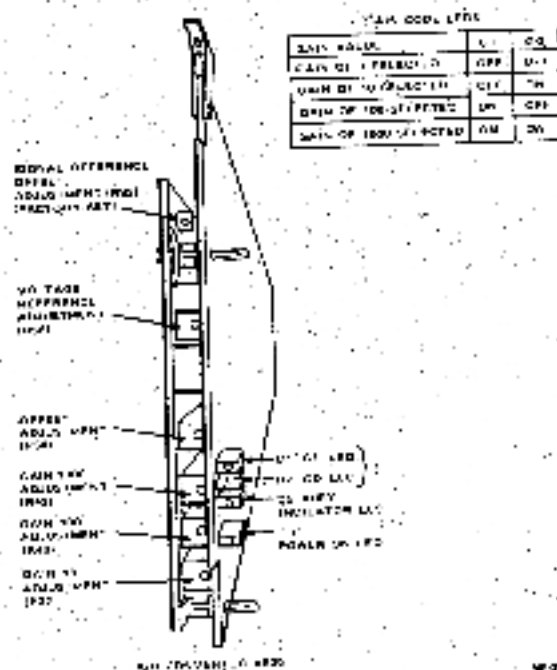

Figure 3-17 A6005 Adjustments

3.5.3.3 Module A6005 Checkout Procedure -

- Test summary
 - Verifies that the output voltage increments of both channels are equal and linear beginning at 2 V up to a maximum of 10 V with no spikes.
- Equipment required
 - An A908 anning test module
 - An oscilloscope.
- Test configuration
 - See Figure 3-18.

The A6005 (two-channel) anning output module checkout procedures are presented in Figure 3-19.

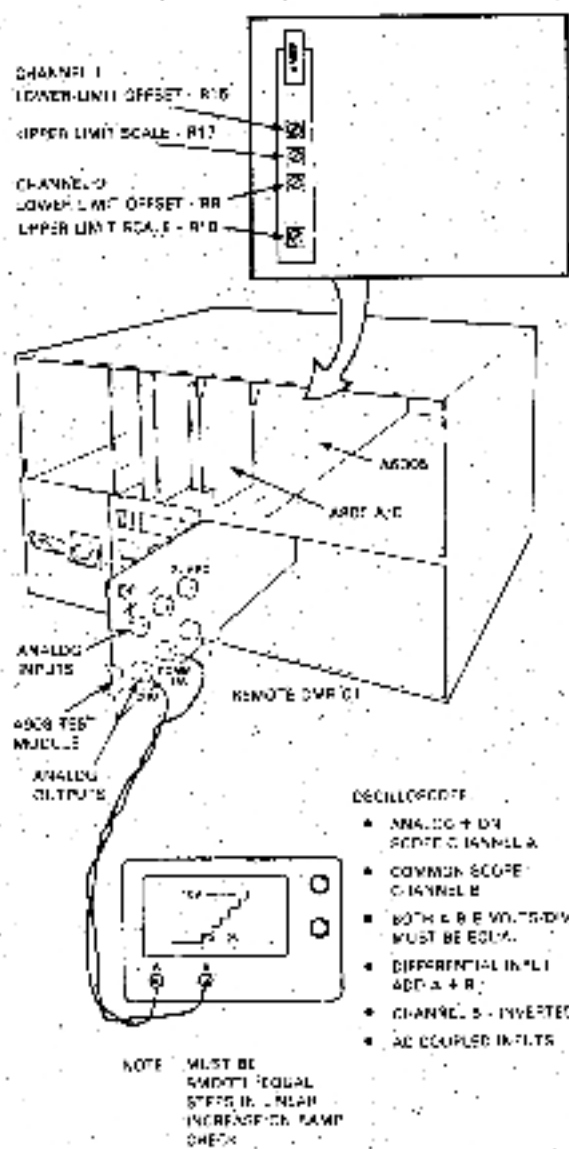

Figure 3-18 A6005 Test Configuration

64 TEST AND CALIBRATION

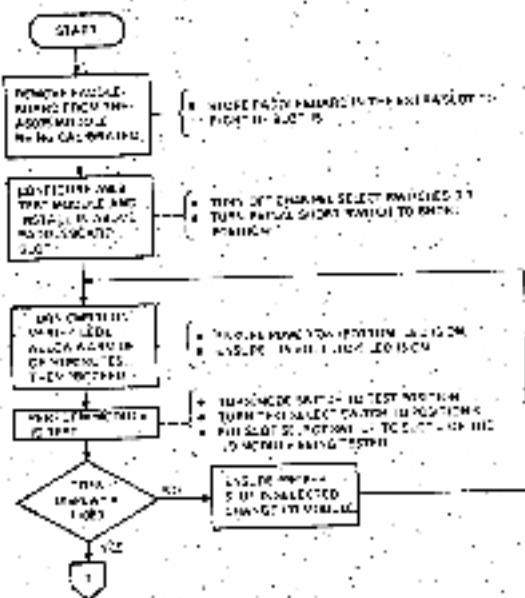

Figure 3-19 A6005 Checkout Procedure (Sheet 1 of 2)

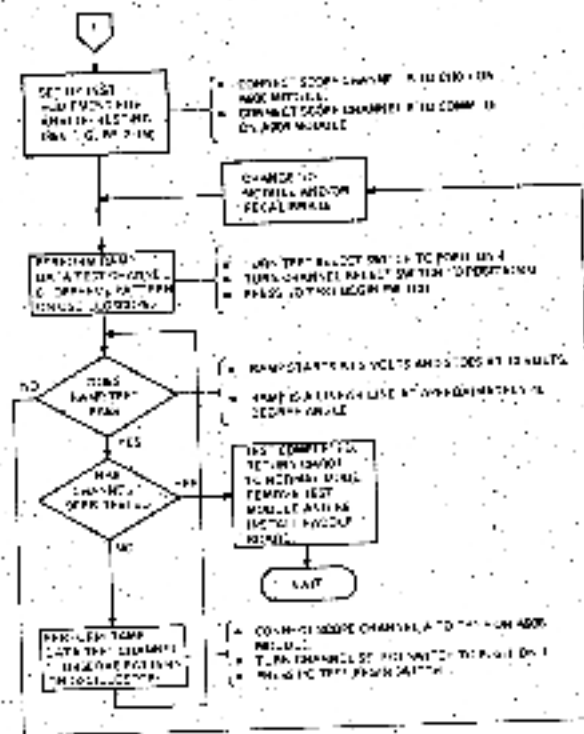

Figure 3-19 A6005 Checkout Procedure (Sheet 2 of 2)

66 TEST AND CALIBRATION

3.5.3.4 Module A6005 Calibration Procedure

- Calibration summary

To adjust the A6005 output; lower limit to $2\text{ V} \pm 10\text{ MV}$ and upper limit to $10\text{ V} \pm 10\text{ MV}$ for both channels.

- Equipment required

- An A908 analog test module.
- A precision digital voltmeter.

- Calibration configuration

Basically the same as the test configuration of Figure 3-18 except that scope is replaced by voltmeter.

The A6005 calibration procedure is presented in Figure 3-20. Also refer to Figure 3-21 for adjustment locations.

3.5.3.5 Modules A1004/A1005 Checkout Procedure

- Test summary

- Verifies that each channel is independent from all other channels.
- Verifies that input analog signal leads are connected to the analog bus.
- Verifies that relays cannot close on an error condition.

- Required equipment

- An A805 A/D converter module.
- An A908 test module.
- A voltage standard.

- Test configuration

See Figure 3-14.

The A1004/A1005 checkout procedure is presented in Figure 3-22. Table 3-2 lists the correct maintenance panel LED display readings for selected test voltage inputs. Test results must comply with these values.

TEST AND CALIBRATION 67

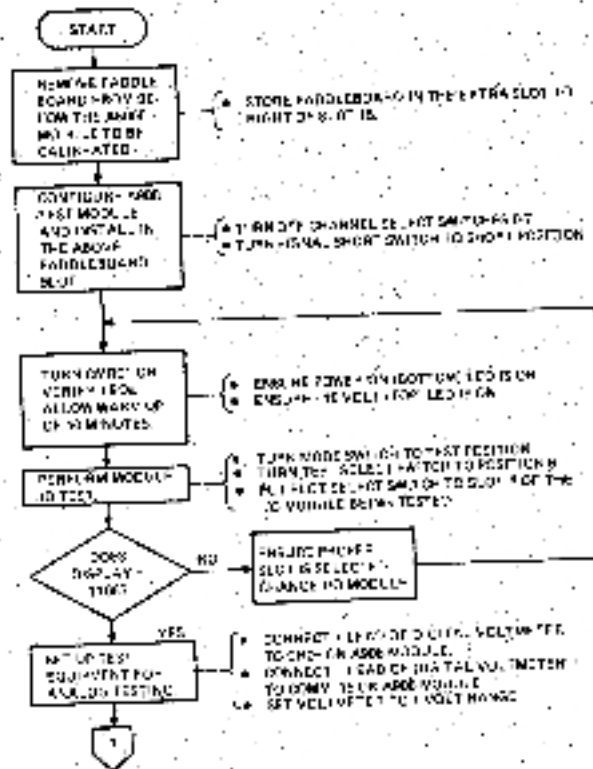

Figure 2-20 A6005 Calibration Procedures (Sheet 1 of 2)

8B TEST AND CALIBRATION

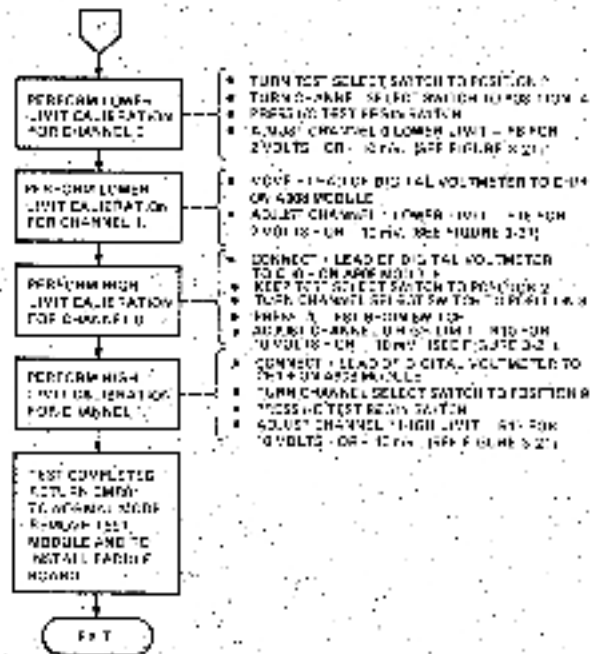

Figure 3-20 A6005 Calibration Procedures (Sheet 2 of 2)

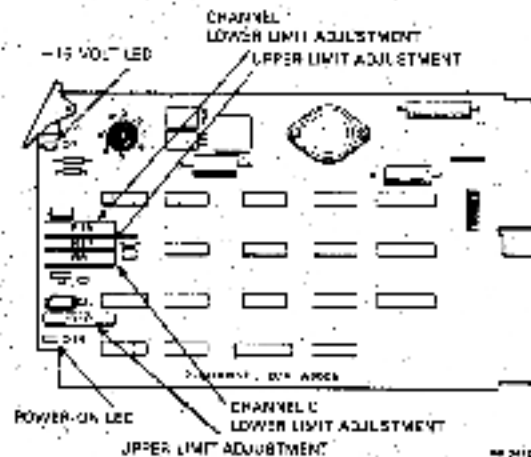

Figure 3-21 A6005 Adjustments

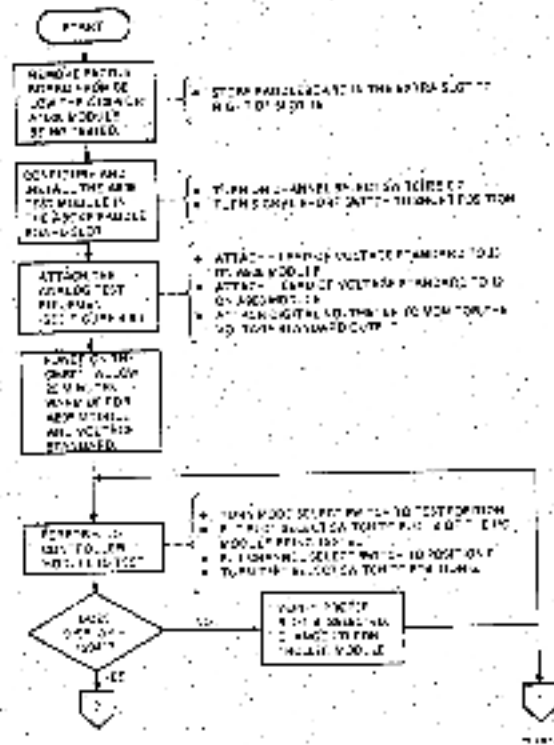

Figure 3-22 A1004/A1005 Checkout Procedure (Sheet 1 of 3)

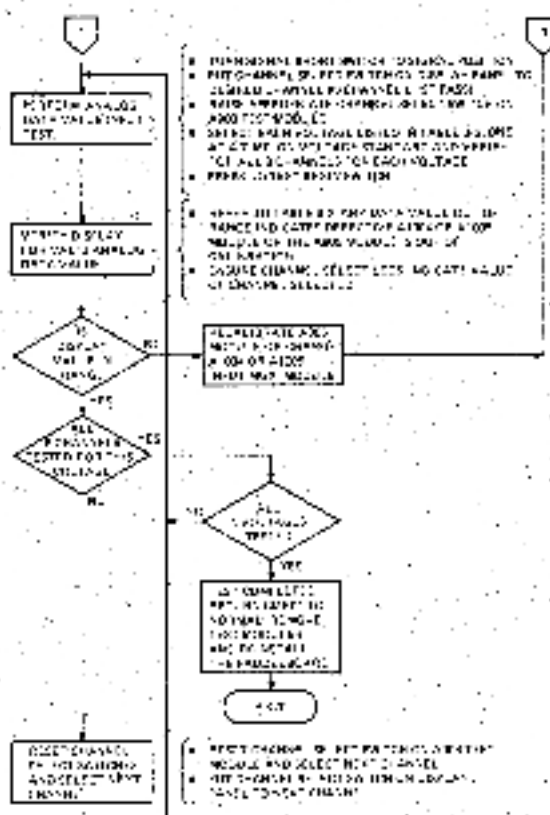

Figure 3-22 A1004/A1005 Checkout Procedure (Sheet 3 of 3)

72 TEST AND CALIBRATION

Table 3-2 Valid Test Results

Input Voltage	Maintenance Panel Display Readings
Short or 0 Volts	130001 to 230006 or 30001 to 30006
2 Volts	1454 to 1470
4 Volts	3140 to 3154
6 Volts	4620 to 4644
8 Volts	6114 to 6113

3.5.3.6 Modules M8986, M8987, or M8994 Checkout Procedures -

- Test summary
 - Verifies that all relays energize and that contacts close or open correctly.
 - Verifies that each relay LED indicator operates correctly.
- Required equipment:
 - A G5153 digital I/O test module.
 - A BC08R-03 interconnect cable.
 - A CMRT1-11 test paddleboard.
- Module configuration:
 - M8986 uses mercury type B relays with normally closed contacts.
 - M8987 uses dry reed relays with normally open contacts.
 - M8994 uses mercury type A relays with normally open contacts.

The checkout procedure for the M8986, M8987, or M8994 digital output modules is presented in Figure 3-23. Also refer to Figure 3-8 for LED locations.

3.5.3.7 Module M8993 Checkout Procedure -

- Test summary
 - Verifies each of 16 process points to ensure that register bits are set correctly and that the LEDs function correctly.

• Required equipment

- A GS153 digital I/O test module.
- A BC08R-03 interconnect cable.
- A CMRT1-31 test paddleboard.

The M8983 checkout procedure is presented in Figure 3-24, while test results are provided in Table 3-3.

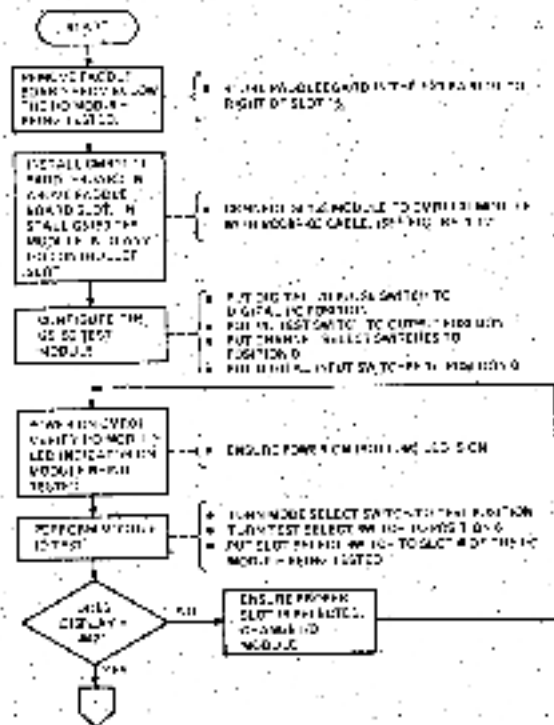

Figure 3-23 M8986, M8987, or M8994 Checkout Procedures (Sheet 1 of 2)

74 TEST AND CALIBRATION

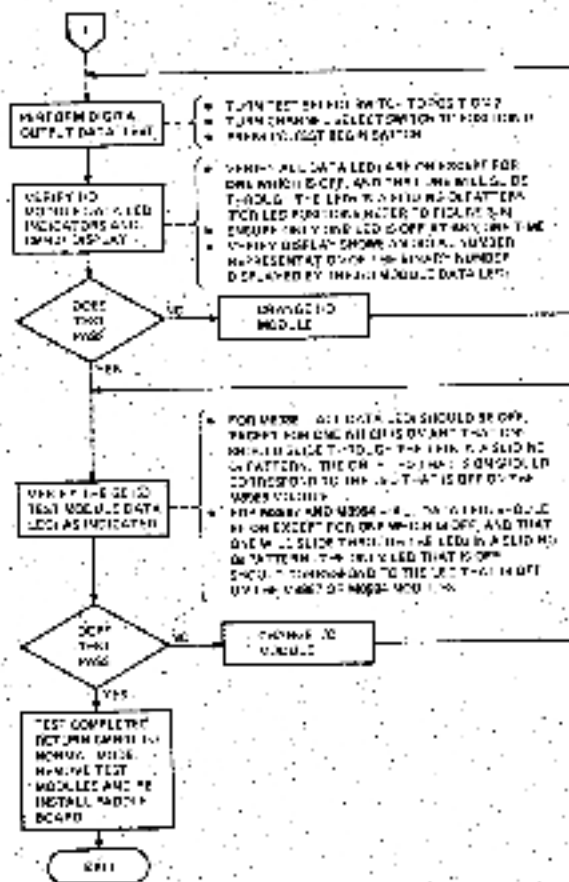

Figure 3-2A. M8986, M8987, or M8994 Checkout Procedures (Sheet 2 of 2)

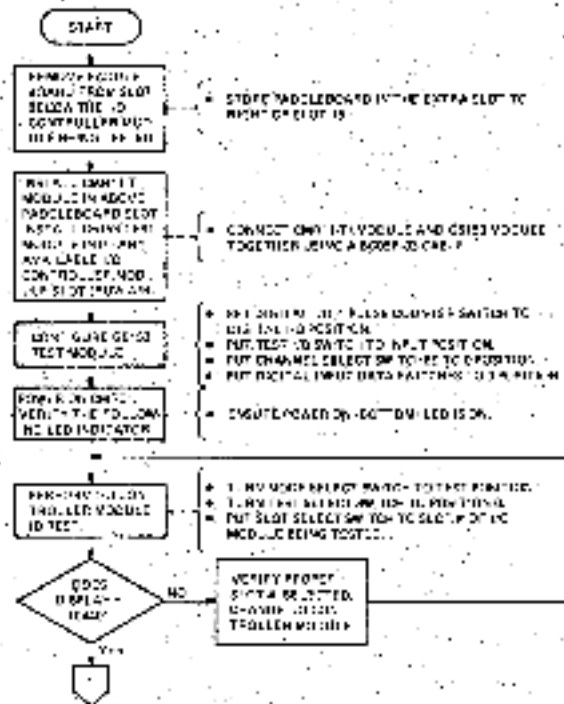

Figure 3-24 MR953 Checkout Procedure (Sheet 1 of 2)

76 TEST AND CALIBRATION

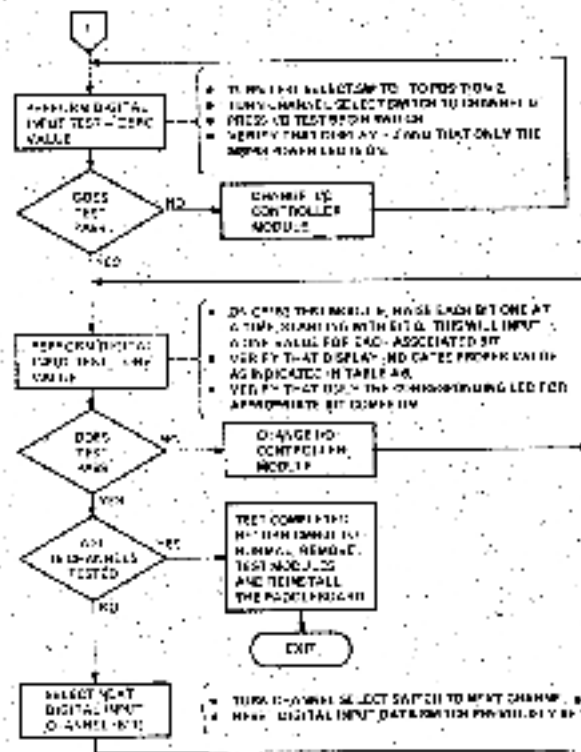

Figure 3-24 M8993 Checkout Procedure (Sheet 2 of 2)

Table 3-3 M8993 Test Results

Bit Set = J	Display Panel LEDs
No Bits Set	0
Bit 0 Set	1
1 Set	2
2 Set	4
3 Set	10
4 Set	20
5 Set	40
6 Set	100
7 Set	200
8 Set	400
9 Set	1000
10 Set	2000
11 Set	4000
12 Set	10000
13 Set	20000
14 Set	40000
15 Set	100000

3.5.3.8 Module M8997 Checkout Procedure

- Test Summary
 - Verifies that all channels correctly accumulate pulses.
 - Verifies that only the channel selected accumulates pulses.
 - Verifies that counter can be reset and begin counting again.
 - Checks the operation of each channel LED.
- Required equipment
 - A G5153 digital I/O test module.
 - A BC058C-03 interconnect cable
 - A CMRT1-11 test paddleboard.

The checkout procedure for the M8997 is presented in Figure 3-25.

3.5.4 CMR01 Communications Line Adjustments

This procedure is the last procedure to be performed prior to testing a complete CMR11/CMV13 system using the network exerciser ((C)ZCME program #3). These adjustments are critical to ensure proper communications between the host and remotes.

78 TEST AND CALIBRATION

These procedures *must* be performed during the installation process and when troubleshooting efforts determine that they are required. However, these procedures *must* also be performed whenever the system configuration is changed by either adding or deleting remote units.

Figure 3-26 outlines the procedure for making these critical adjustments.

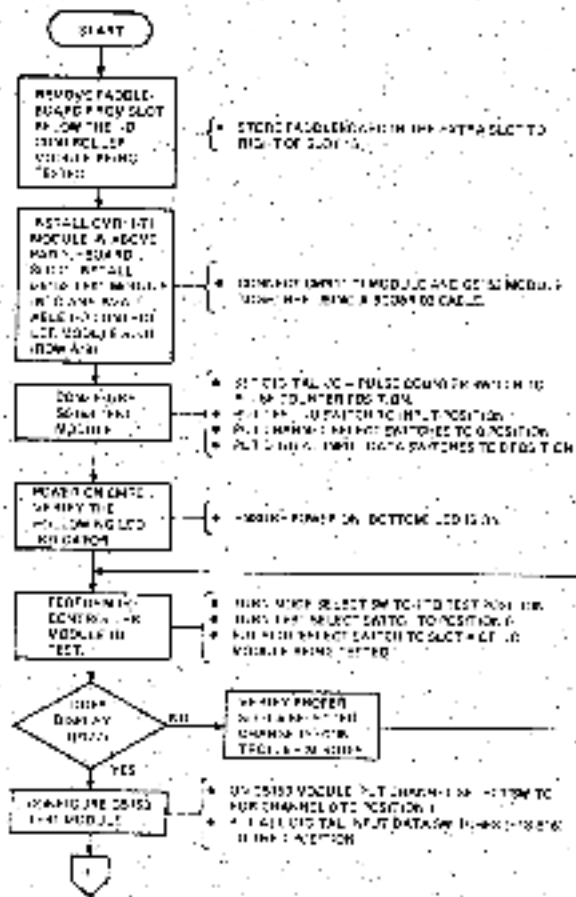

Figure 3-25 M8997 Checkout Procedure (Sheet 1 of 2)

TEST AND CALIBRATION 79

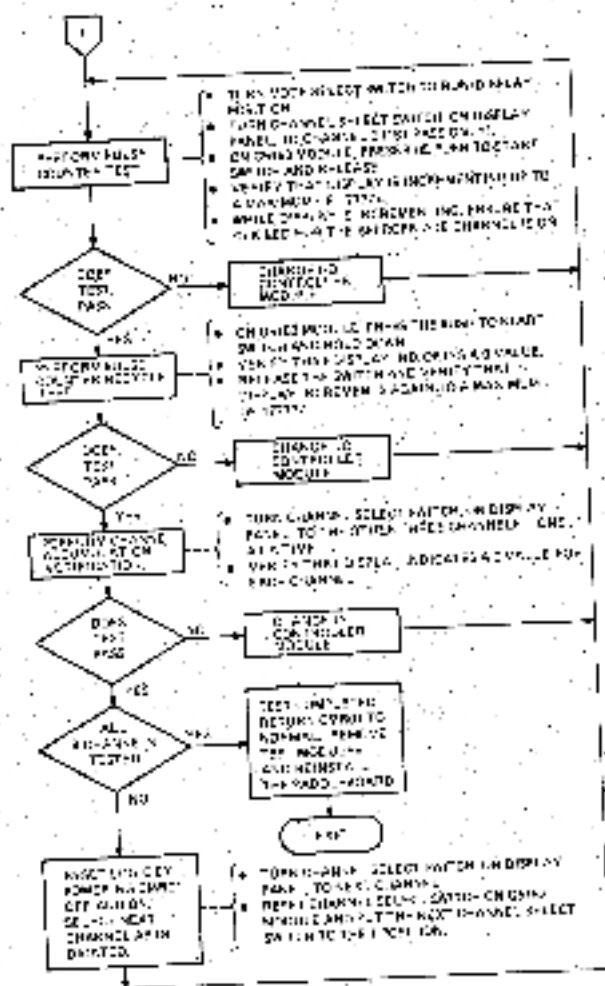

Figure 3-25 MB997 Checkout Procedure (Sheet 1 of 2)

80 TEST AND CALIBRATION

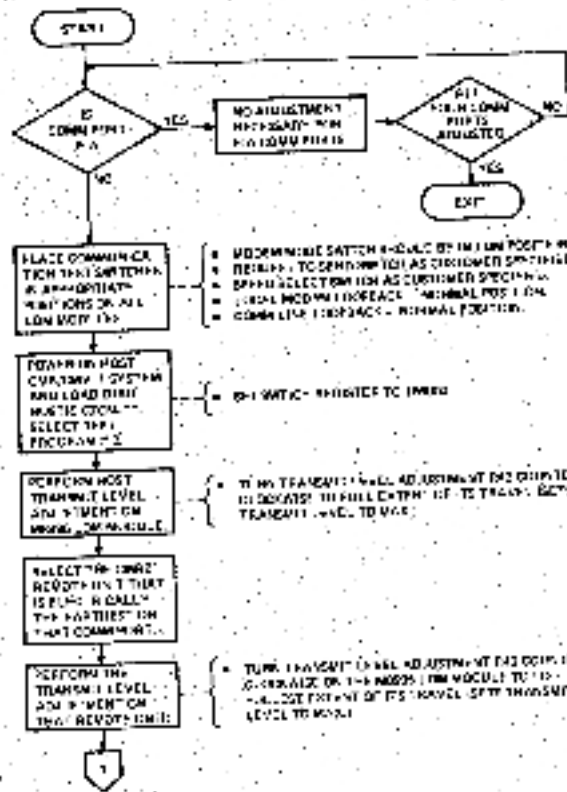

Figure 3-26 CMRD1 Communications Line Adjustments (Sheet 1 of 3)

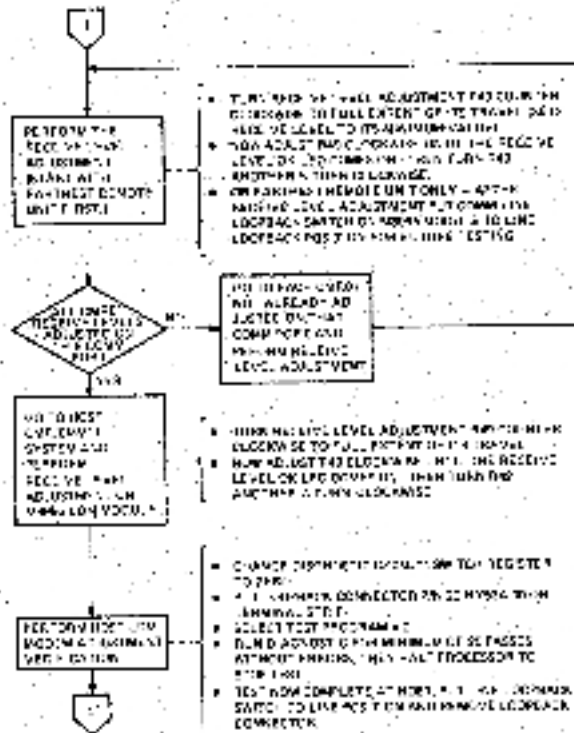

Figure 3-26 CMR01 Communications Line Adjustments (Sheet 2 of 3)

4 CORRECTIVE MAINTENANCE

4.1 GENERAL

This chapter simply reviews the maintenance features available with the CMR11/CMV11 to aid the troubleshooting processes. Also included are some troubleshooting precautions, service limitations, and maintenance aids such as register bit assignments and TECH TIPS/PCD index.

Test and calibration procedures have already been presented in detail in Chapter 3. Although these procedures are started towards installation checkout, they are also used in corrective maintenance; the only difference being the sequence in executing those procedures. For example, as shown in Figure 4-1, the first step for corrective maintenance is to load and execute the system network exerciser [(C)ZCMJ, program #3] to determine if the fault is with the host or one of the remote units.

4.2 MAINTENANCE FEATURES

1. (C)ZCMJ*[†] diagnostic - Used to test host controller and system network level
 - a. Diagnostic media
 - 1) Functional diagnostic - (C)ZCMJ*[†] paper tape, AK-F913*-M1.
 - 2) DEC/X11 diagnostic - (C)XCMJ*[†] paper tape, AK-S331*-MC.
 - b. Precautions
 - 1) When running program #3, make sure that the proper loopback switches or test connector are installed correctly.

[†]Revision level

84 CORRECTIVE MAINTENANCE

- 2) When executing program #3, if the line speed is slow (300 baud) - the run time is considerable (up to 30 minutes)
 - 3) Be sure that the customer's process is terminated and the I/O cable modules removed.
2. Reimage firmware - Used to test the three major sections of the remote unit: controller, I.DM, and R-BC'S options.
- a. Test equipment
 - 1) Standard field service tool kit.
 - 2) An oscilloscope
 - 3) A precision digital voltmeter.
 - 4) EDC MV-105GJ voltage standard.
 - 5) CMR11-TA test kit; includes test modules G5153 and A908, a test paddleboard CMR11-T1, and a BC08R-D3 cable.
 - b. Precautions
 - 1) For safety reasons, terminate customer's operation and remove ALL I/O paddleboards from slots below R-BC'S
 - 2) Any remote that is added to or removed from the system configuration changes the loading characteristics. This makes it necessary to readjust the communications line adjustments (refer to Section 3:5-4)
 - c. Display panel - Provides the means to implement the firmware and to observe test results
 - 1) Keylock switch (three position)
 - RUN mode - normal position
 - RUN/DISPLAY mode
 - TEST mode - selects one of six test conditions

Position	Selects
1	Display RAM (locations 2000 through 27FF)
2	I/O module test (slow speed)
3	Defined output
4	I/O module test (fast speed)
5	Loopback
6	I/O module ID
7 & 8	Not used

- d. Error readout - Normal error codes are displayed in the three right-hand LEDs of the display. This three digit error code is prefixed by the letter e (refer to Table 3-1). Data errors in loopback testing are indicated by the prefix of a backwards letter e. The erroneous character is displayed (in normal) in the right-hand LEDs. Errors prefixed by the letter u indicate that the loopback test is currently passing, but that an error did occur earlier.

CORRECTIVE MAINTENANCE B7

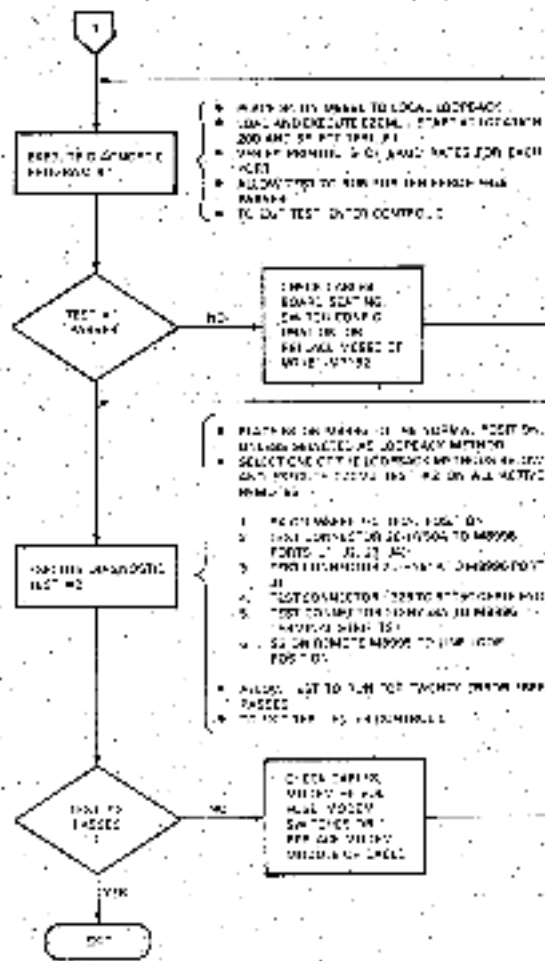

Figure 4-1 CMRT/CMYH Troubleshooting Howchart (Sheet 2 of 2)

88 CORRECTIVE MAINTENANCE

4.3 REGISTER BIT ASSIGNMENTS

Figure 4-2 shows the bit assignments for each of the three registers in the CMR11/CMV11.

4.4 TECH-TIPS/FCO INDEX

As of this printing, there have been no TECH-TIPS or FCOs issued on the CMR11/CMV11.

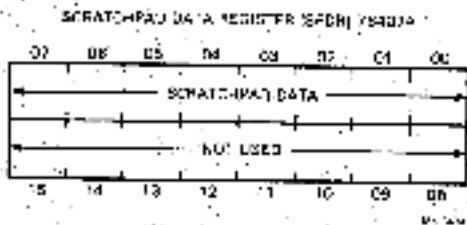
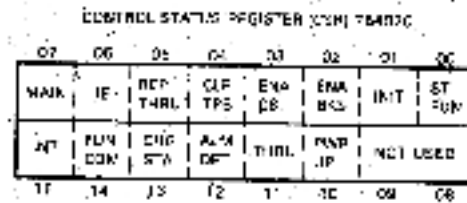

Figure 4-2 CMR11/CMV11 Register Bit Assignments

READER'S COMMENTS

CMR1/CMV11 Distributed Multiprocess Controller
Pocket Service Guide
EX-CMR1 (PS-00)

This Pocket Service Guide is intended for *Field Service Technicians*. Your comments and suggestions will be a valuable and continuous effort to improve its quality and usefulness.

What is your general reaction to this Pocket Service Guide?

	Excellent	Very Good	Good	Fair
Accuracy	<input type="checkbox"/>	<input type="checkbox"/>	<input type="checkbox"/>	<input type="checkbox"/>
Completeness	<input type="checkbox"/>	<input type="checkbox"/>	<input type="checkbox"/>	<input type="checkbox"/>
Organization	<input type="checkbox"/>	<input type="checkbox"/>	<input type="checkbox"/>	<input type="checkbox"/>
Format	<input type="checkbox"/>	<input type="checkbox"/>	<input type="checkbox"/>	<input type="checkbox"/>

What features are most useful?

(Notes, Tables, Illustrations, etc.)

1. _____ 3. _____

2. _____ 4. _____

Does the publication satisfy your needs? Yes No

What errors have you found?

(List page no., table no., and figure no.)

Comments

Name _____

Title _____ Dept. _____

Company _____

Address _____

City _____ State _____ Zip _____

Site Code MK

digital



No Postage,
Necessary
if Mailed in the
United States

BUSINESS REPLY MAIL

FIRST CLASS

PERM. NO. 33

BEDFORD, MA

POSTAGE WILL BE PAID BY ADDRESSEE

Digital Equipment Corporation
Educational Services/Quality Assurance
12 Crosby Drive, BU/E08
Bedford, MA 01730



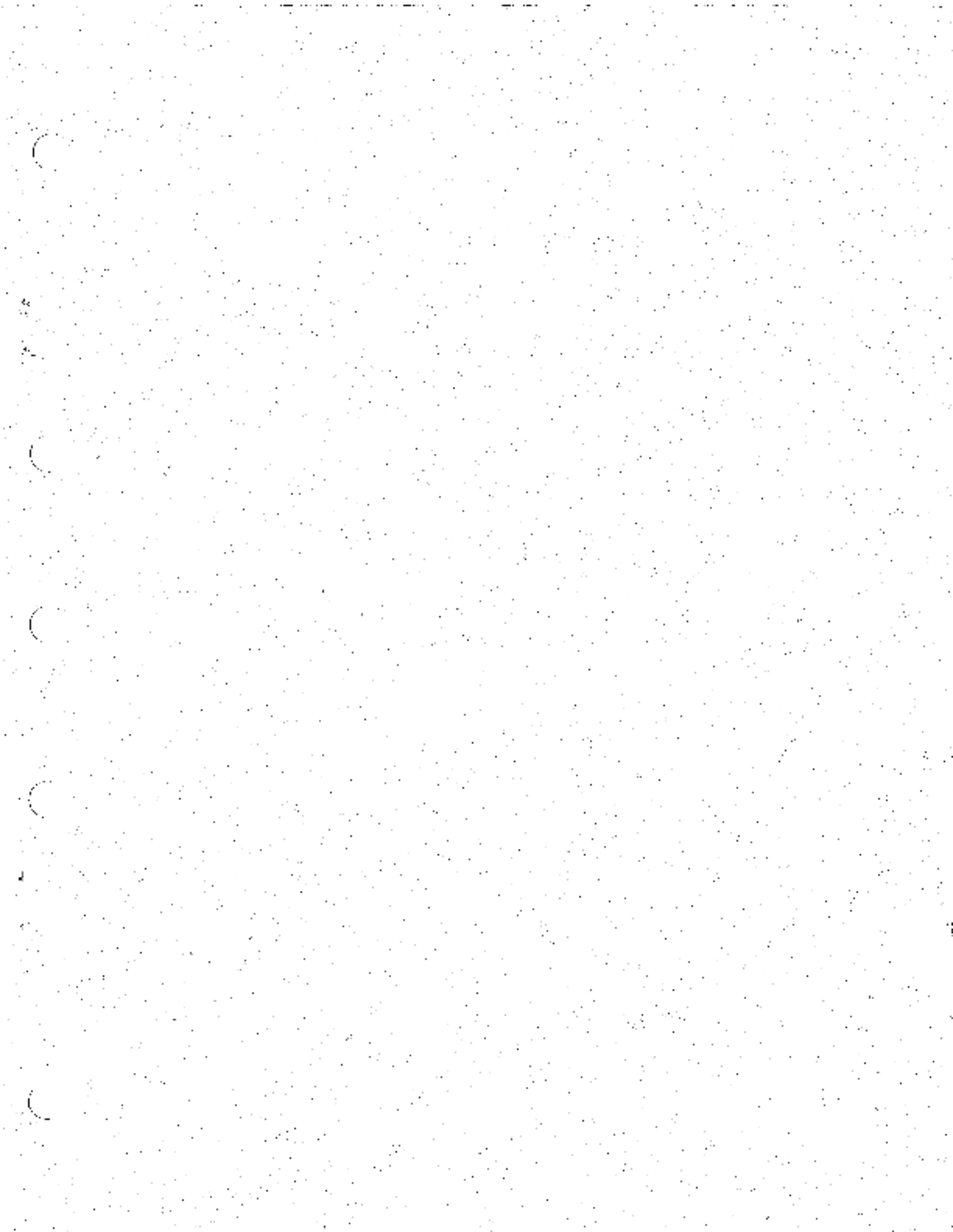

Digital Equipment Corporation • Bedford, MA 01730