

---

# **BA400-Series Chassis Rackmount Installation**

Order Number EK-BA400-IN.001

**Digital Equipment Corporation  
Maynard, Massachusetts**

# Contents

---

Preface	v	
1	Verify Site Preparation	1
2	Check Rackmount Kit	3
3	Remove Enclosure Skins	6
4	Locate Mounting Hardware Positions	8
4.1	Determining Chassis Version (Early or Current)	8
4.2	Restrictions for Early Chassis Versions	9
4.3	Using the Template to Locate the Three Hole Positions	11
5	Locate Shipping Hardware Positions (Shipping Only)	15
6	Mount Isolators	17
7	Mount L-Brackets	18
8	Remove Enclosure Base	22
9	Attach Skis to Bottom of Chassis	25
10	Install Chassis	27

## Appendix A Attaching Shipping Hardware

---

A.1	Installing the Shipping Plates	A-1
A.2	Installing the Shipping Locks	A-3

## Figures

---

1	Two Types of Cabinet Rails and Corresponding Rackmount Kit	2
2	Rackmount Kit Hardware	4
3	Removing Enclosure Skins	7
4	Flanges on BA400-Series Chassis	9
5	Restriction for Upper Isolator (Early Chassis)	10
6	Locating Upper and Lower Isolator Positions	12
7	Locating L-bracket (Top Screw Position)	14
8	Attaching Clip-On U-Nuts to Shipping Hardware Holes	16

9	Mounting Isolators .....	17
10	Mounting L-Brackets on H9646 and H9642 Cabinets .....	19
11	Mounting L-Brackets on H9A00 Cabinets .....	20
12	Securing the L-Bracket Halves .....	21
13	Removing Enclosure Base .....	23
14	Removing the Regulatory Label Plate .....	24
15	Attaching Skis to Chassis .....	26
16	Installing the Chassis .....	28
17	Center Chassis Before Tightening Screws .....	29
A-1	Installing the Shipping Plates .....	A-2
A-2	Shipping Locks .....	A-3
A-3	Installing the Shipping Locks .....	A-4

## Tables

---

1	Contents of Bag of Mounting Hardware .....	5
2	Contents of Bag of Shipping Hardware .....	5

# Preface

---

This manual provides installation procedures for rackmounting BA400-series chassis in H9A00, H9646, and H9642 cabinets using the special mounting hardware contained in the BA400-series rackmount kit. There are two variations of the BA400-series rackmount kit:

- The BA400–CB kit is used with the H9A00 cabinet.
- The BA400–CA kit is used with the H9642 and H9646 cabinet.

**NOTE:** *BA400-series chassis cannot be mounted in SAxxx storage array cabinets.*

## Intended Audience

This document is intended only for Digital service personnel and qualified self-maintenance customers.

## Warnings, Cautions, and Notes

Warnings, cautions, and notes appear throughout this guide. They have the following meanings:

<b>WARNING</b>	Provides information to prevent personal injury.
<b>CAUTION</b>	Provides information to prevent damage to equipment or software.
<b>NOTE</b>	Provides general information about the current topic.

The following symbols appear on the system or expander power supply. Please review their definitions below.



This warning symbol indicates risk of electrical shock.



**Warning.** *To reduce the risk of injury, do not remove modules, Integrated Storage Elements (ISEs), or the power supply. No user-serviceable parts are inside. Refer servicing questions to your Digital service representative or to your qualified self-maintenance personnel.*

*This equipment has not been designed for connection to an IT power system (a power system without a directly grounded neutral conductor).*

*This equipment should be plugged into a properly grounded receptacle only.*

*This system contains an automatic voltage select power supply. Voltage selection is not required prior to installation.*

## Introduction

The BA400–CB rackmount kit allows you to mount a BA400-series chassis in a H9A00 cabinet. The BA400–CA rackmount kit allows you to mount a BA400-series chassis in H9646 or H9642 cabinets.

**NOTE:** *BA400-series chassis cannot be mounted in SAxxx storage array cabinets.*

Installing a BA400-series chassis requires the use of special mounting hardware. Use the procedures in this manual to install the mounting hardware and to rack mount the chassis.



If you are rack mounting a system that is to be shipped, you will be instructed at certain steps in the procedure to refer to Appendix A for additional procedures and hardware necessary to protect the chassis during shipment.

Throughout this manual, the truck symbol is used to indicate procedures or material required for shipping rack-mounted systems.

## 1 Verify Site Preparation

Before installing the rackmount kit:

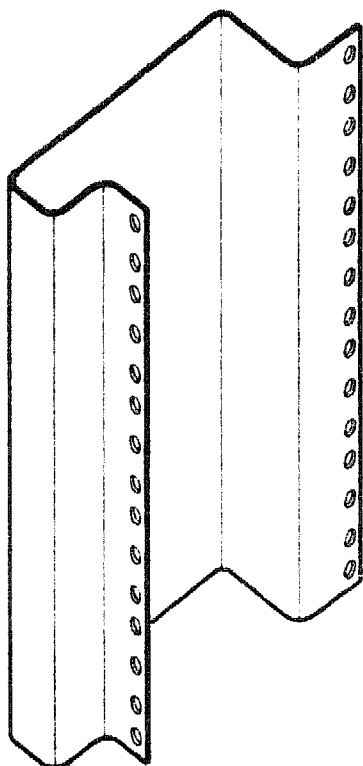
- Be sure the site and cabinet meet all environmental and power requirements for the systems or expanders to be rack mounted. This information is found in the system site preparation manual contained in the *Customer Hardware Information* binder shipped with each system.
- Be sure the cabinet has at least 25.5 inches of vertical space necessary to accommodate the BA400-series chassis, the mounting brackets, and required clearance space.

**NOTE:** *Earlier BA400-series chassis may require more vertical space due to limitations requiring specific rail-hole patterns for mounting hardware. See Section 4.1.*

- Make sure the rackmount kit variation matches the cabinet type. Figure 1 shows the two types of cabinet rails and their corresponding rackmount kit number.
- For previously installed systems, make sure the customer has backed up the software and shut down the operating system.

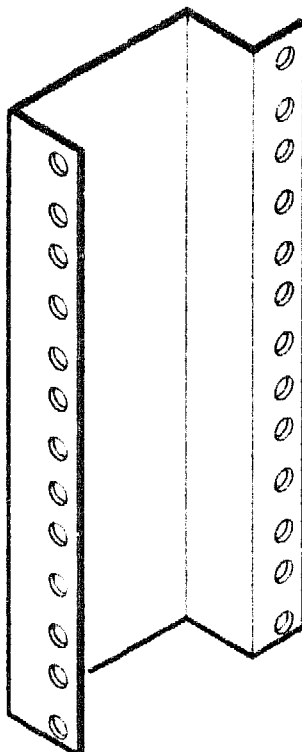
**Figure 1: Two Types of Cabinet Rails and Corresponding Rackmount Kit**

H9A00 Cabinets



Uses  
BA400-CB Rackmount Kit

H9646 And H9642 Cabinets



Uses  
BA400-CA Rackmount Kit

MLO-006700

The following tools are needed to rack mount the chassis:

- Flat-blade screwdriver
- Phillips screwdriver
- Adjustable wrench or ratchet socket set
- Torque wrench

**WARNING:** *Two people are needed to lift and move the BA400-series chassis.*

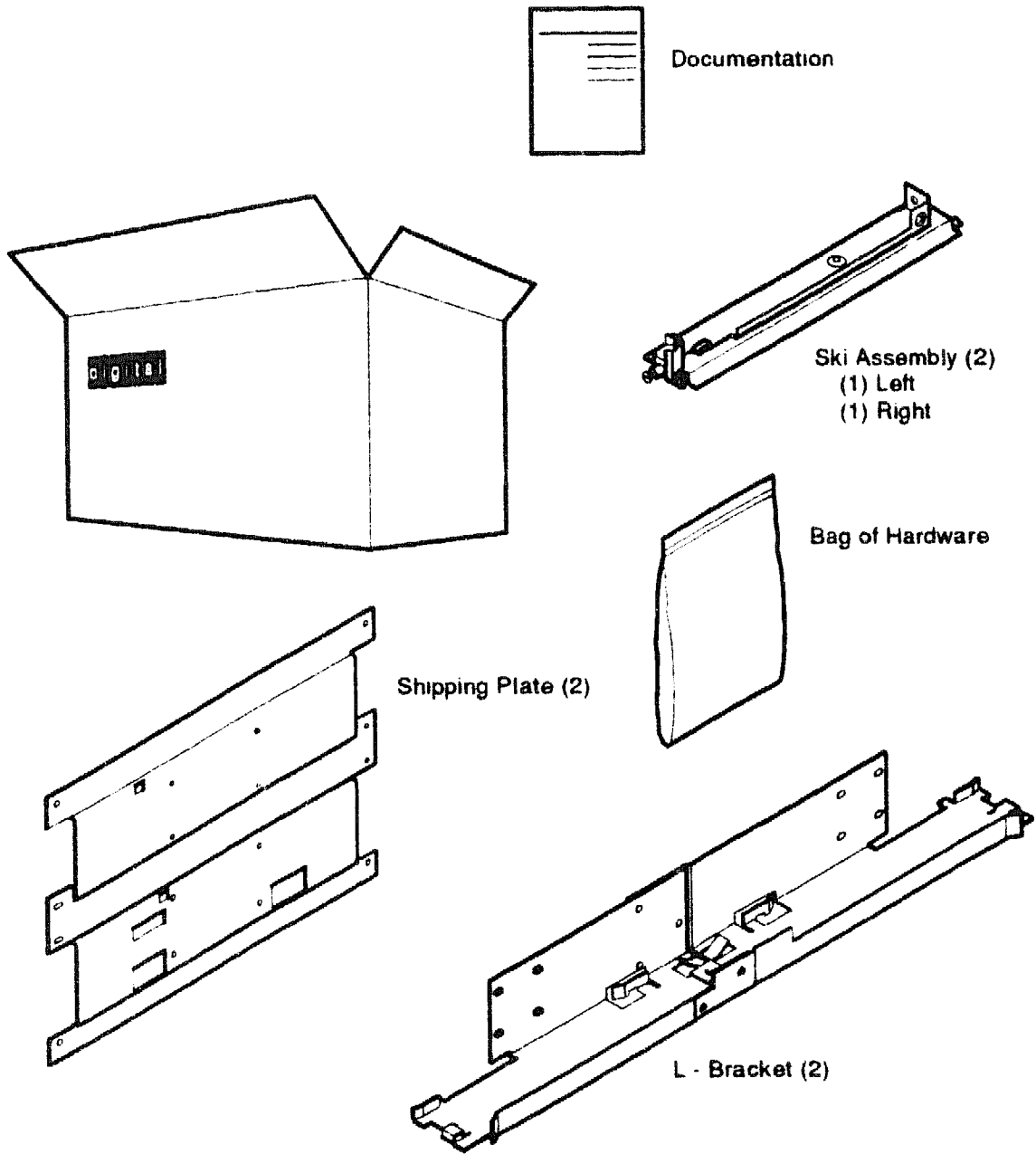
## 2 Check Rackmount Kit

Each rackmount kit contains the following hardware (Figure 2):

- L-brackets (2)
- Ski assembly (2)
- Shipping plates (2, red (for shipping use only))
- Bag of hardware



**Figure 2: Rackmount Kit Hardware**



MLO-006286

The bag of hardware contains the following:

**Table 1: Contents of Bag of Mounting Hardware**

Description	Quantity
Isolators, cylindrical	4
Nuts, kep 1/4-20	12
Screws, hex 1/4-20 x 3/8 long	6
Screws, Phillips flat-head 1/4-20	2
Studs, flush 1/4-20 x 5/8 long	8
Washers, flat	8
Washers, lock	6
Bag of shipping hardware <sup>1</sup>	1

<sup>1</sup>For shipping use only.



If the cabinet will not be shipped, disregard the shipping plates and bag of shipping hardware, as they will not be needed.

The bag of shipping hardware contains the following:

**Table 2: Contents of Bag of Shipping Hardware**

Description	Quantity
Shipping locks (red)	4
Nuts, clip-on, u-nut	20
Screws, hex 10-32 x 1-1/4 long	4
Screws, hex, with captive lock washer 10-32 x 1/2 long	24
Washers, flat	20

### **3 Remove Enclosure Skins**

Before removing the enclosure skins, make sure the power switch is set to off (0) and the ac power cable is unplugged.

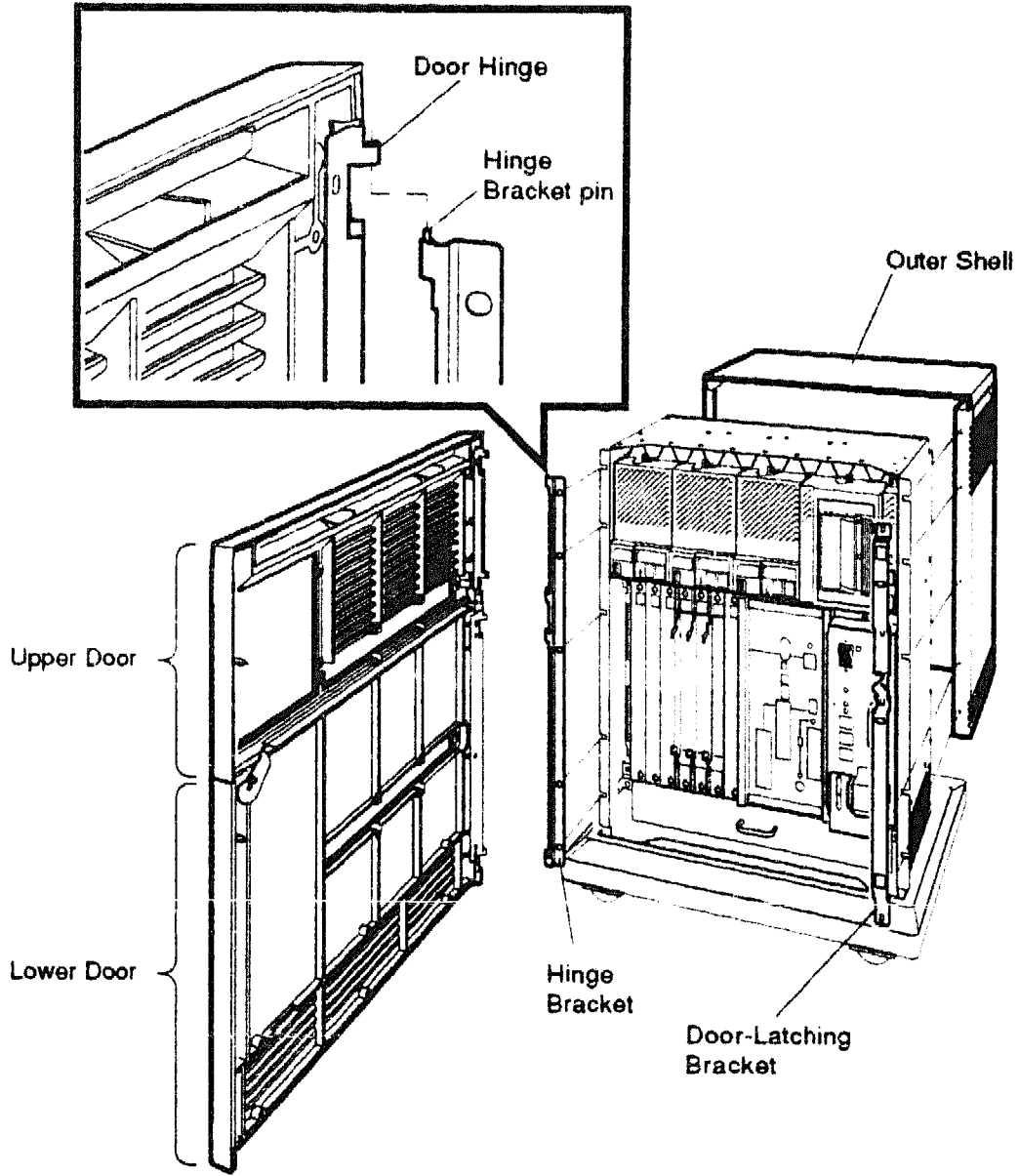
Remove the enclosure skins as follows (refer to Figure 3):

1. Unlock and open the upper and lower doors of the enclosure.
2. Remove the upper door by swinging it out more than 90 degrees and lifting it off its hinges.
3. Remove the bottom door by swinging it out more than 90 degrees and lifting it off its hinges.
4. Remove the door-latching bracket on the right side by removing the three self-tapping screws and one 6–32 screw. Remove the two remaining self-tapping screws that secure the right side of the outer shell to the chassis.

Remove the hinge bracket on the left by removing the five self-tapping screws.

5. Lift the enclosure's outer shell off the chassis.

**Figure 3: Removing Enclosure Skins**



MLO-004222

## **4 Locate Mounting Hardware Positions**

Three hole positions on the left and right vertical rails must be identified before installing mounting hardware:

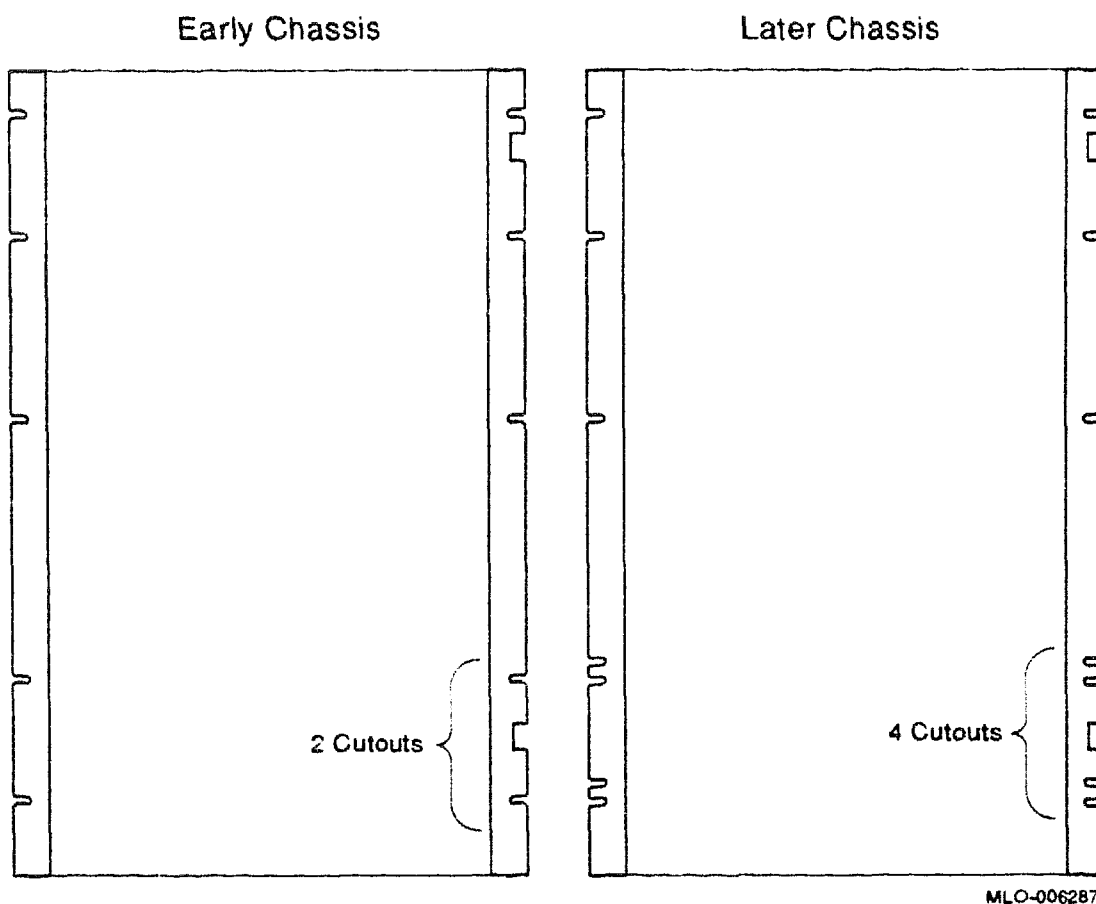
- Upper isolator position
- Lower isolator position
- L-bracket position (top screw)

### **4.1 Determining Chassis Version (Early or Current)**

Before using the foldout template at the back of this manual to locate the three mounting hardware positions, you must check the BA400-series chassis to determine if it is an early or current version.

Early versions of the chassis have only two cutouts at the bottom of the front flanges (Figure 4). The current version has four cutouts at the bottom of the front flanges.

**Figure 4: Flanges on BA400-Series Chassis**

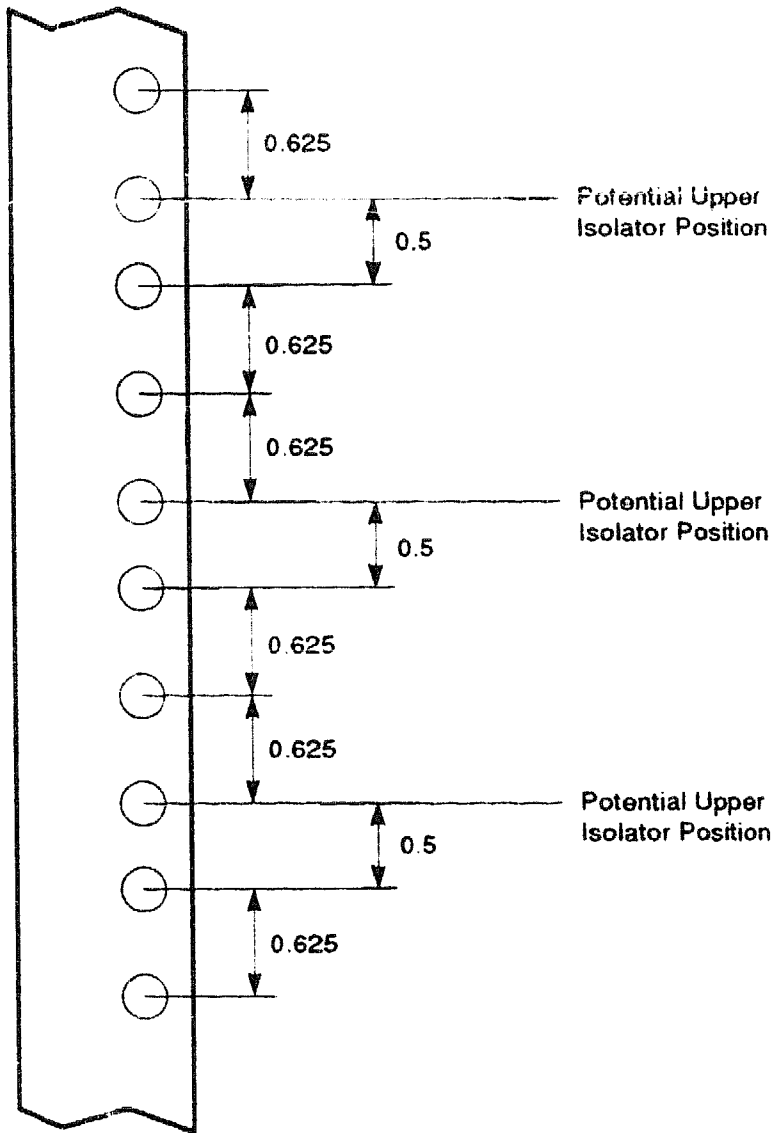


## 4.2 Restrictions for Early Chassis Versions

The early chassis require that the upper-isolator position on the cabinet vertical rails be restricted to those holes with a 1/2-inch space to the next hole below. Figure 5 shows the repeating hole pattern and limited hole positions for the upper isolator.

**NOTE:** *Later versions of the chassis have no such restrictions for the upper isolator position.*

**Figure 5: Restriction for Upper Isolator (Early Chassis)**



MLO-006288

### 4.3 Using the Template to Locate the Three Hole Positions

The foldout template at the back of this manual is a quick and easy tool for locating the three mounting hardware positions. The template includes required clearances at the top and bottom of the chassis.

**NOTE:** *A minimum of 25.5 inches of vertical space is required for the installation (this includes clearances and mounting hardware). Restrictions on positioning early chassis may require additional space.*

Use the template as follows:

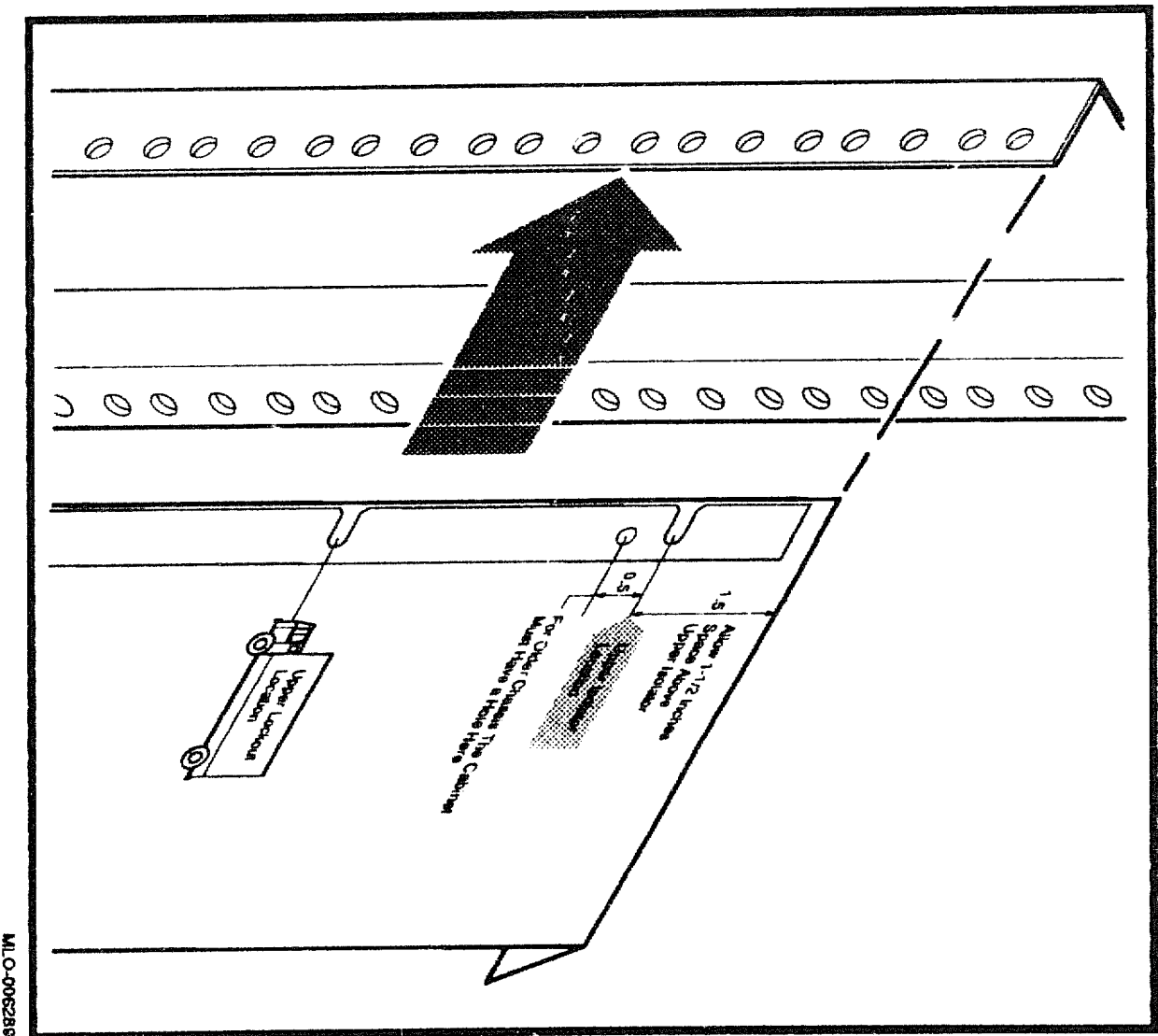
1. Find the foldout template at the back of the manual.
2. Prepare the template by folding it at the top where indicated.
3. Align the template with the holes on the front of the left vertical rail. Mark the holes for the upper and lower isolators (Figure 6).
4. Repeat step 3 for the right vertical rail.

**NOTE:** *Remember that early versions of the chassis restrict upper isolator positions to those holes with a 1/2-inch space to the hole below.*

*Also, early versions of the chassis have only two cutouts at the bottom of the flange.*



**Figure 6: Locating Upper and Lower Isolator Positions**

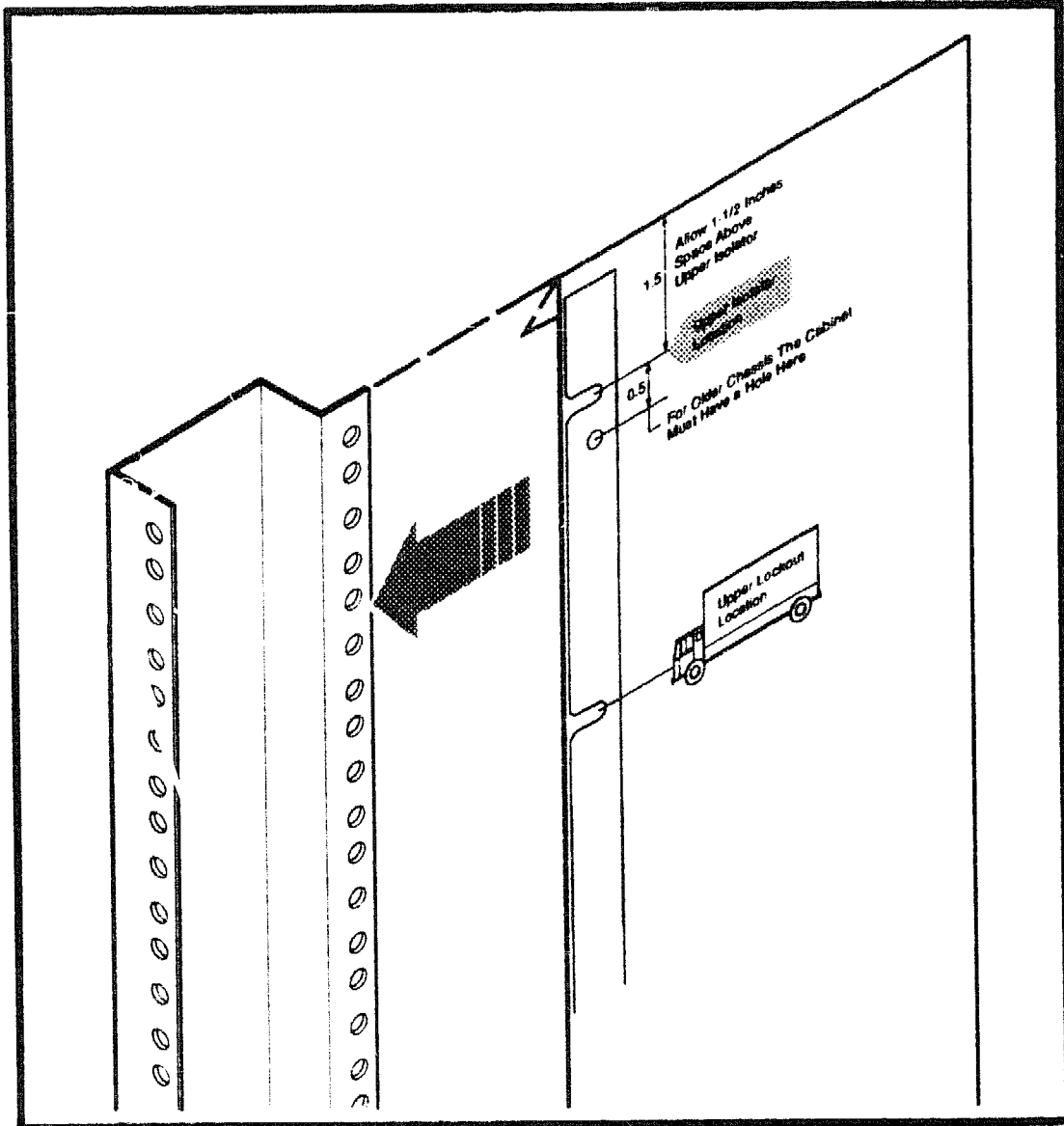


5. Align the template with the holes on the inside of the left vertical rail. Mark the top hole position for the L-bracket. (Figure 7).

**NOTE:** *Be sure that the template is registered according to the upper-isolator-hole position on the front of the vertical rail. Align the template so that the upper-isolator-hole positions correspond.*

6. Repeat step 5 for the right vertical rail.

**Figure 7: Locating L-bracket (Top Screw Position)**



MLO-006290

## 5 Locate Shipping Hardware Positions (Shipping Only)



Special hardware to lock out the shock isolators is needed if the cabinet is to be shipped. If you are rack mounting a system at the customer site—not preparing the cabinet for shipping—skip this step.

**CAUTION:** *Shipping a rackmounted BA400-series chassis without installing the rackmount shipping hardware will destroy the isolators and can seriously damage system components.*

Six hole positions on the left and right vertical rails must be located before mounting the shipping hardware. Use the template as follows to locate the shipping hardware positions:

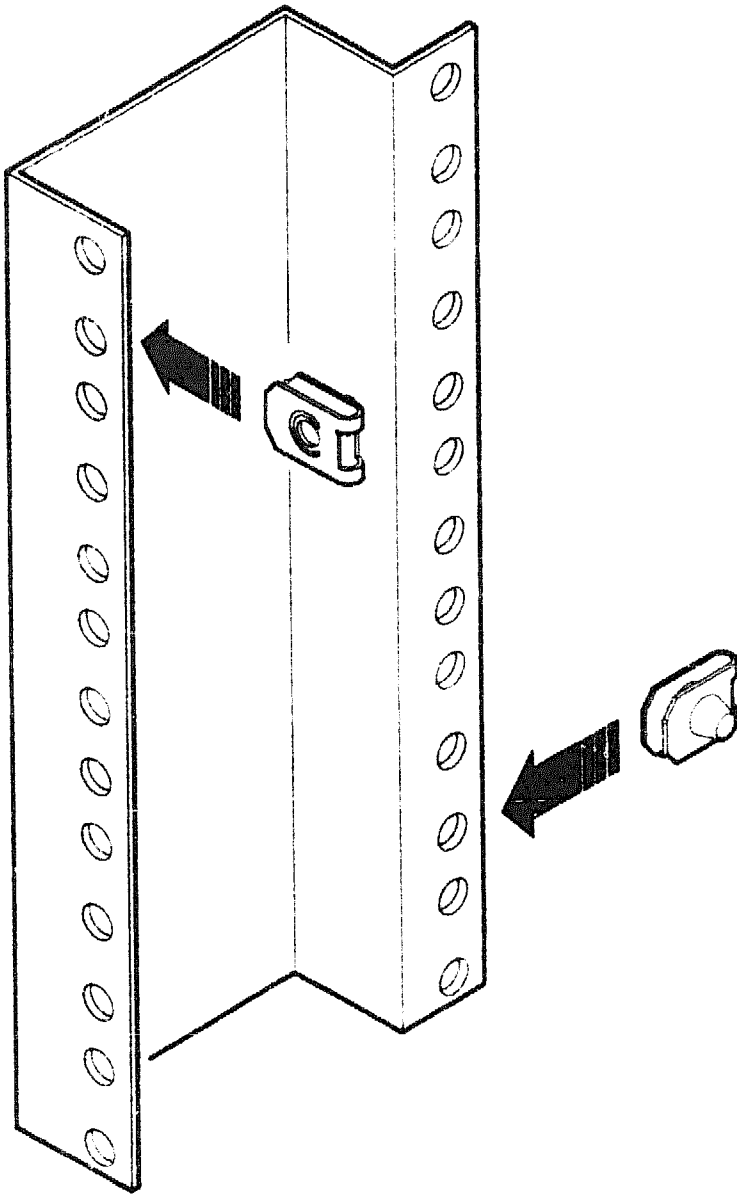
1. Align the template with the holes on the front of the left vertical rail, as in Section 4.3. Mark the holes for the upper and lower shipping locks. Repeat this step for the right vertical rail.
2. Align the template with the holes on the inside of the left vertical rail, as in Section 4.3.

**NOTE:** *Be sure that the template is registered according to the upper-isolator-hole position on the front of the vertical rail. Align the template so that the upper isolator hole positions correspond.*

Mark the four holes for the shipping plate. Repeat this step for the three remaining vertical rails.

3. Attach the clip-on u-nuts to the 20 shipping hardware holes (Figure 8).

**Figure 8: Attaching Clip-On U-Nuts to Shipping Hardware Holes**

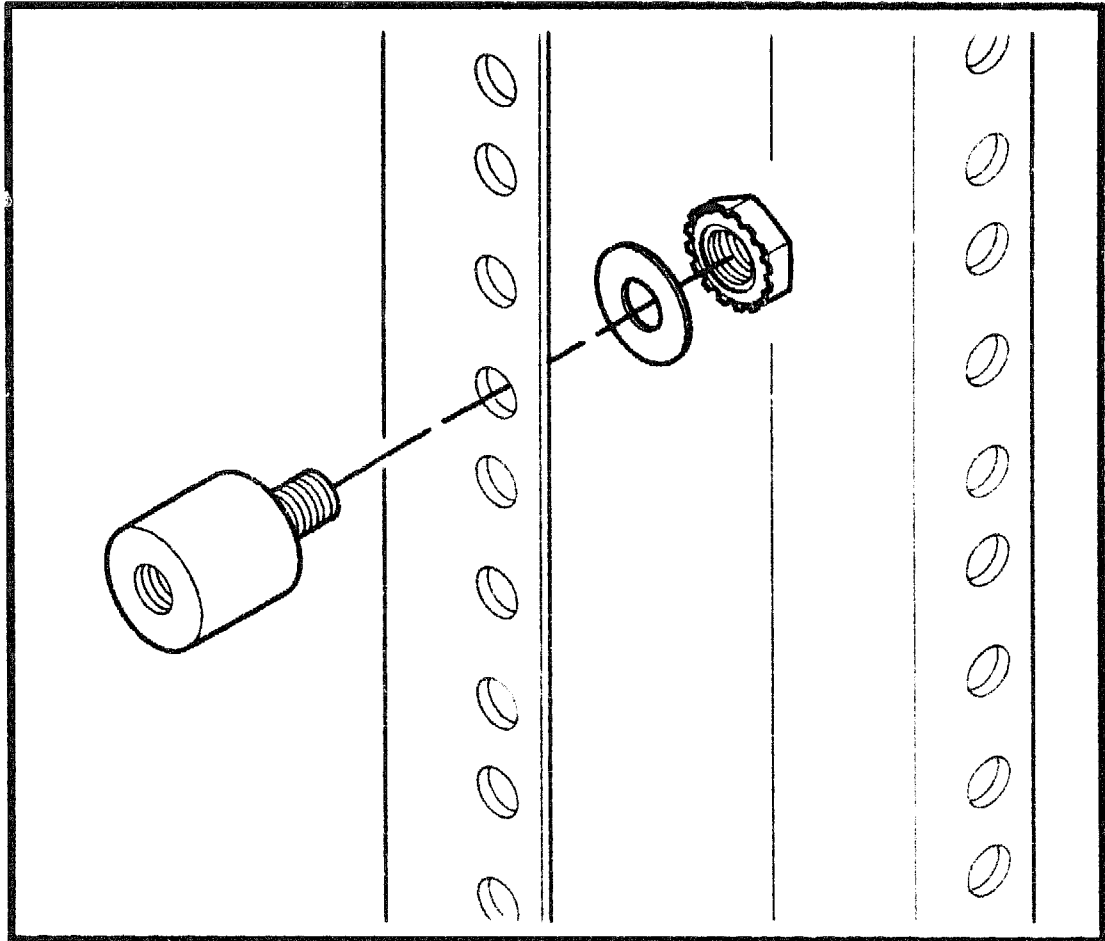


MLO-006291

## 6 Mount Isolators

Mount the upper and lower isolators on the front of the right and left vertical rails using keps nuts and flat washers as shown in Figure 9. (Torque keps nuts to 50 in · lbf (inch · pounds).)

Figure 9: Mounting Isolators



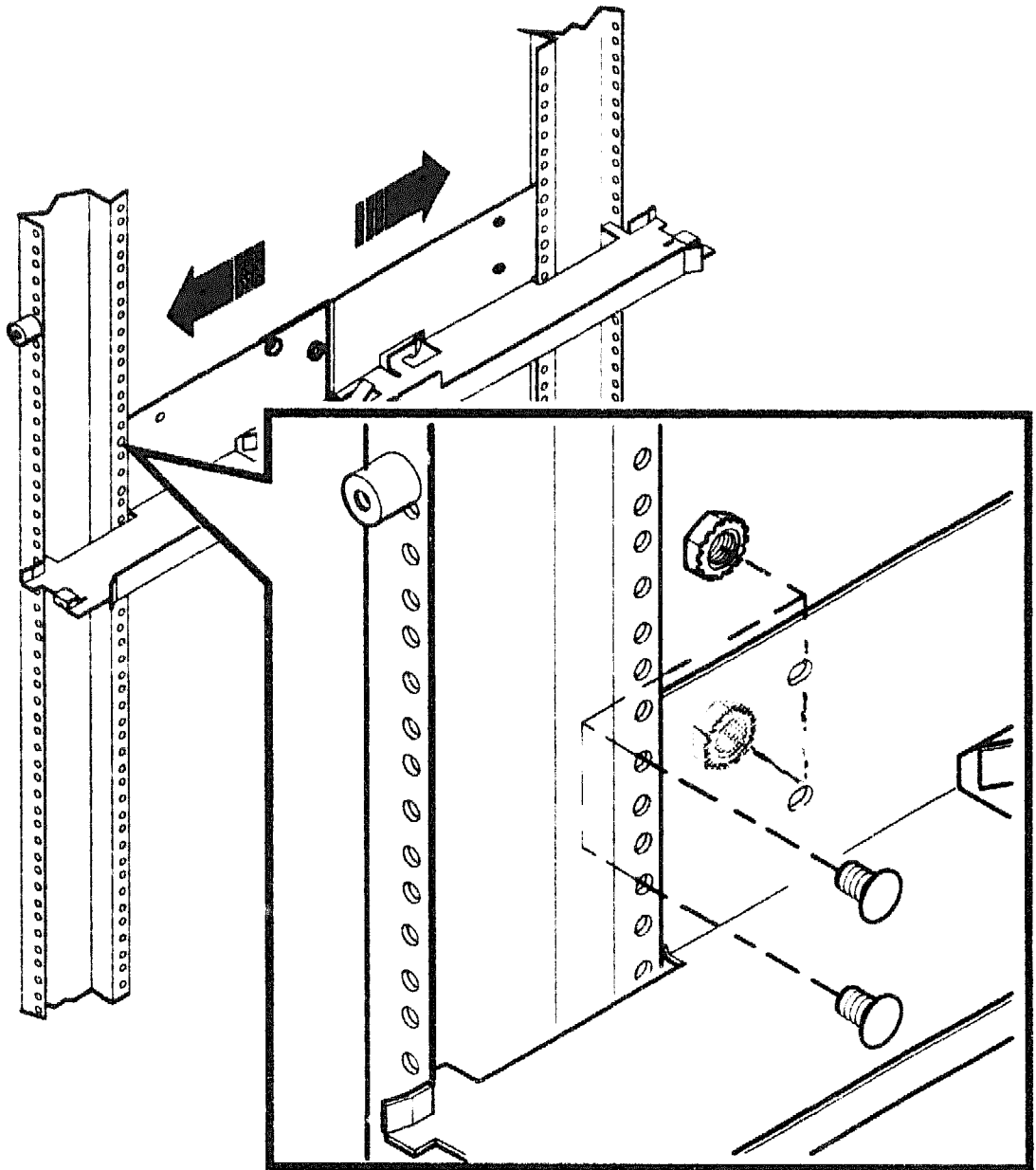
MLO-006292

## 7 Mount L-Brackets

Mount the L-brackets on the inside of the vertical rails on the left and right sides as follows. For H9646 and H9642 cabinets (BA400–CA rackmount kit), refer to Figures 10 and 12; for H9A00 cabinets (BA400–CB rackmount kit), refer to Figures 11 and 12:

1. Mount an L-bracket on the left vertical rails of the cabinet using the top screw hole positions identified in Step 4. Use four 1/4-20 flush studs and kep nuts. Do not tighten the kep nuts.

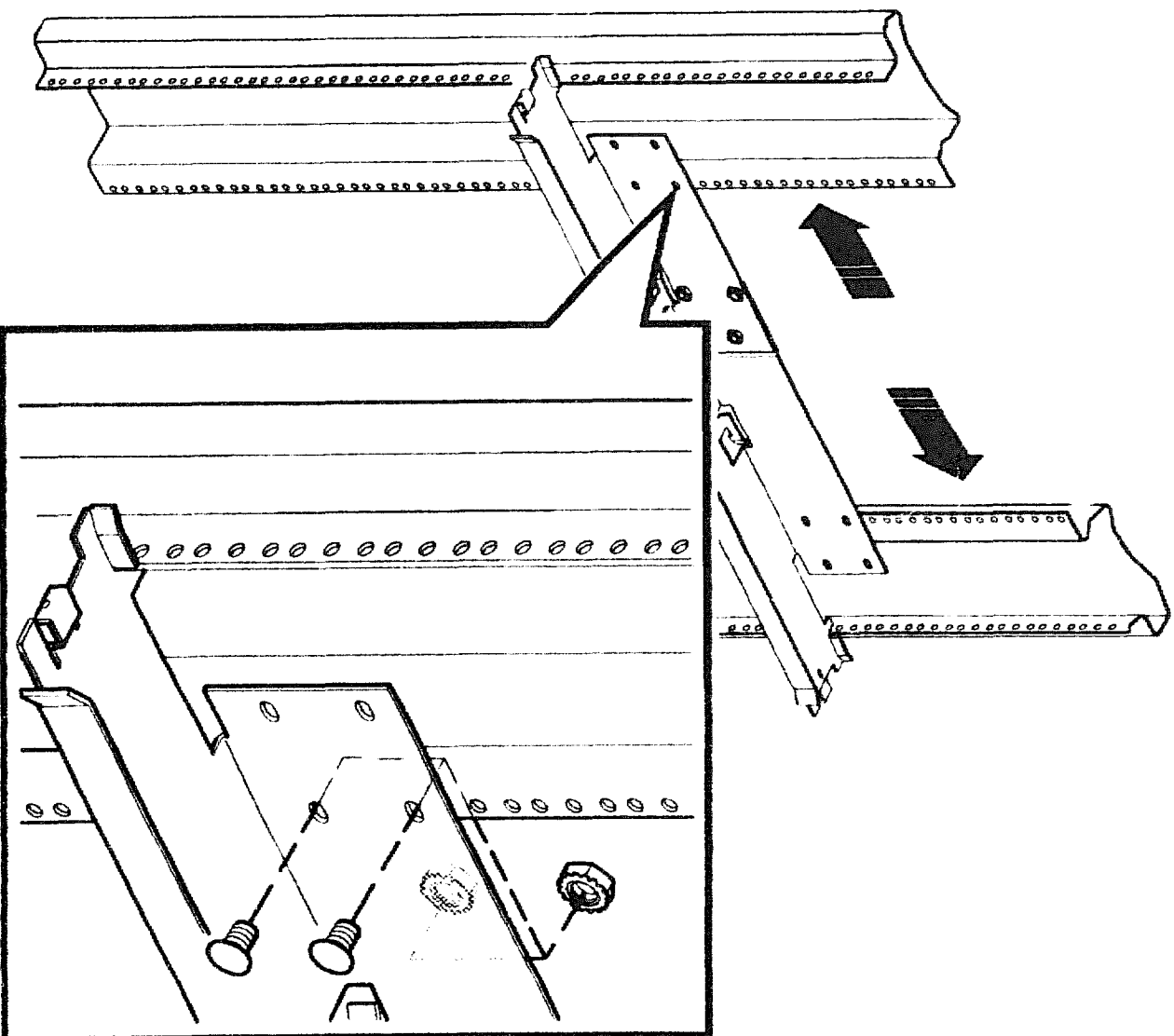
**Figure 10: Mounting L-Brackets on H9646 and H9642 Cabinets**



MLC-006293



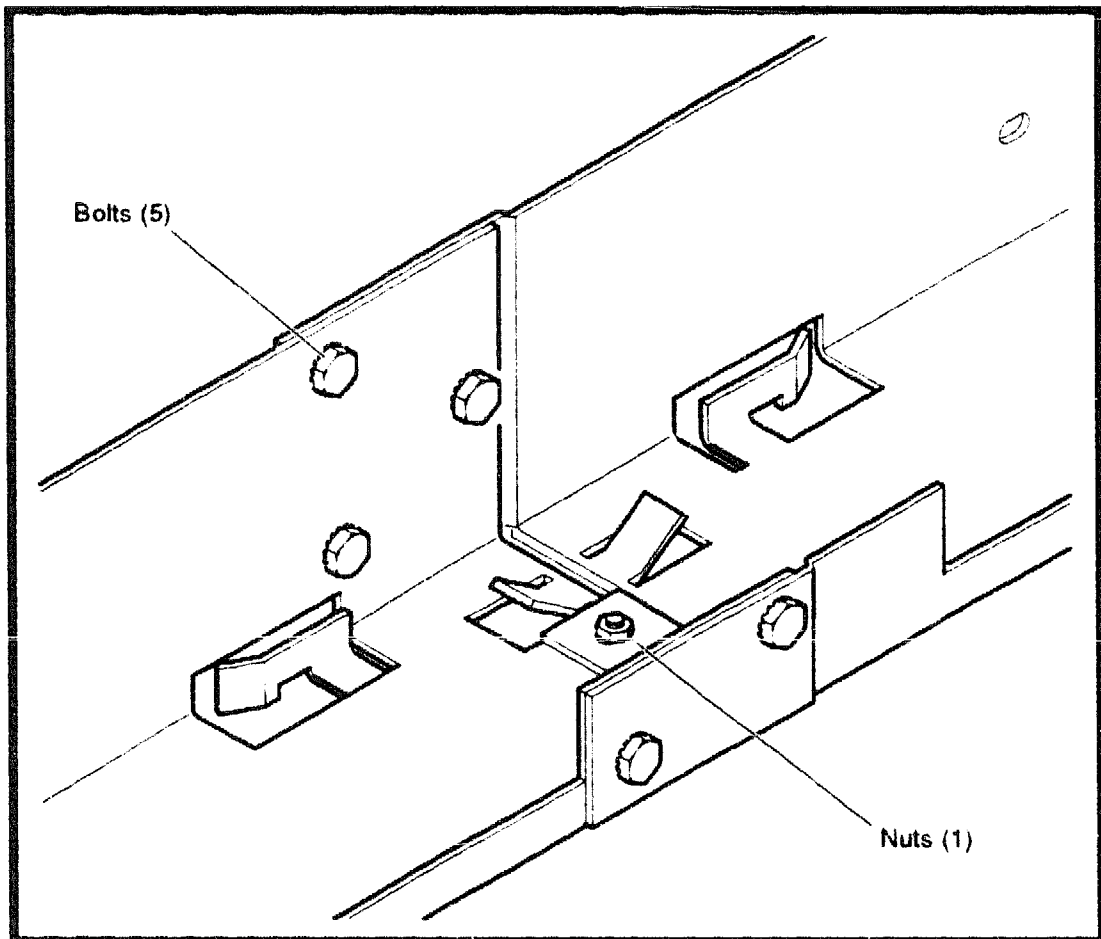
**Figure 11: Mounting L-Brackets on H9A00 Cabinets**



MLC-006701

2. Slide both halves of the L-bracket as far apart as they will go and tighten the five bolts and one nut (Figure 12) to secure the halves (torque to 20 in · lbf).
3. Tighten the keps nuts to the vertical rails (torque to 50 in · lbf).
4. Repeat the procedure to mount an L-bracket on the right side of the cabinet.

**Figure 12: Securing the L-Bracket Halves**



MLO-006294

## 8 Remove Enclosure Base

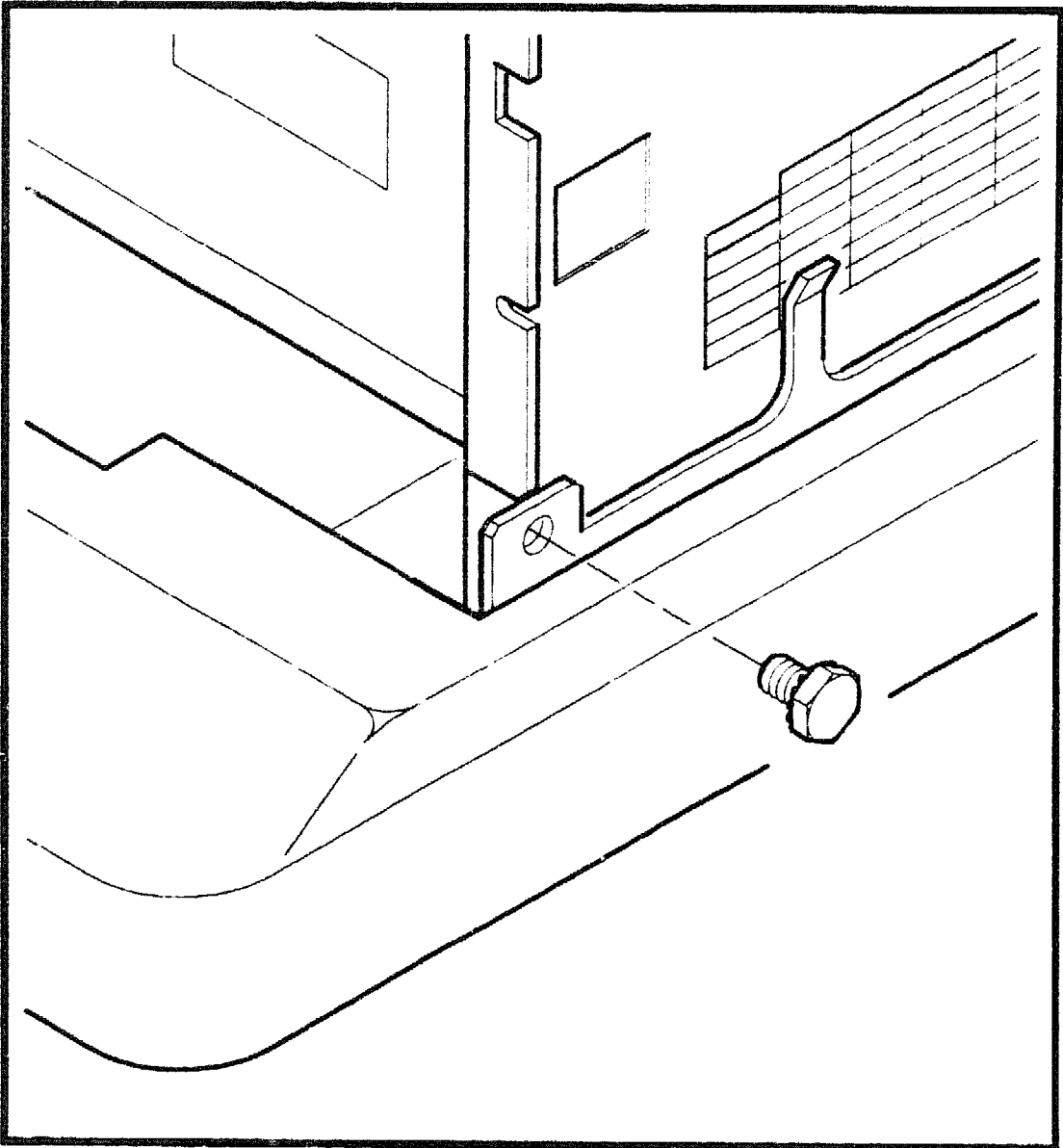
Remove the enclosure base as follows (refer to Figure 13):

1. Remove the four bolts that hold the chassis to the enclosure base.
2. With the aid of an assistant, lift the chassis free of the base.

**WARNING:** *Lifting the chassis requires two people.*

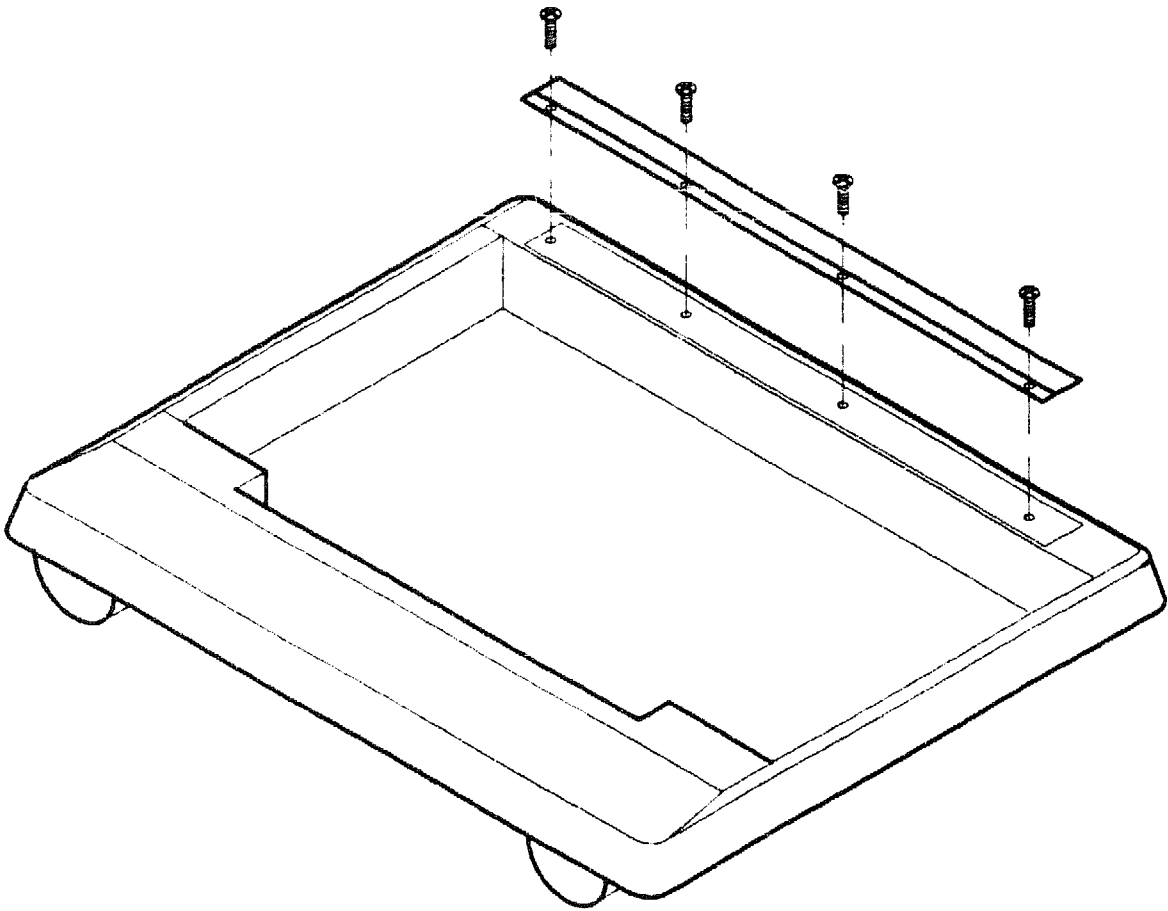
3. Remove the four self-taping screws that hold the regulatory label plate to the base (Figure 14).

**Figure 13: Removing Enclosure Base**



MLO-006295

**Figure 14: Removing the Regulatory Label Plate**



MLC-006702

## 9 Attach Skis to Bottom of Chassis

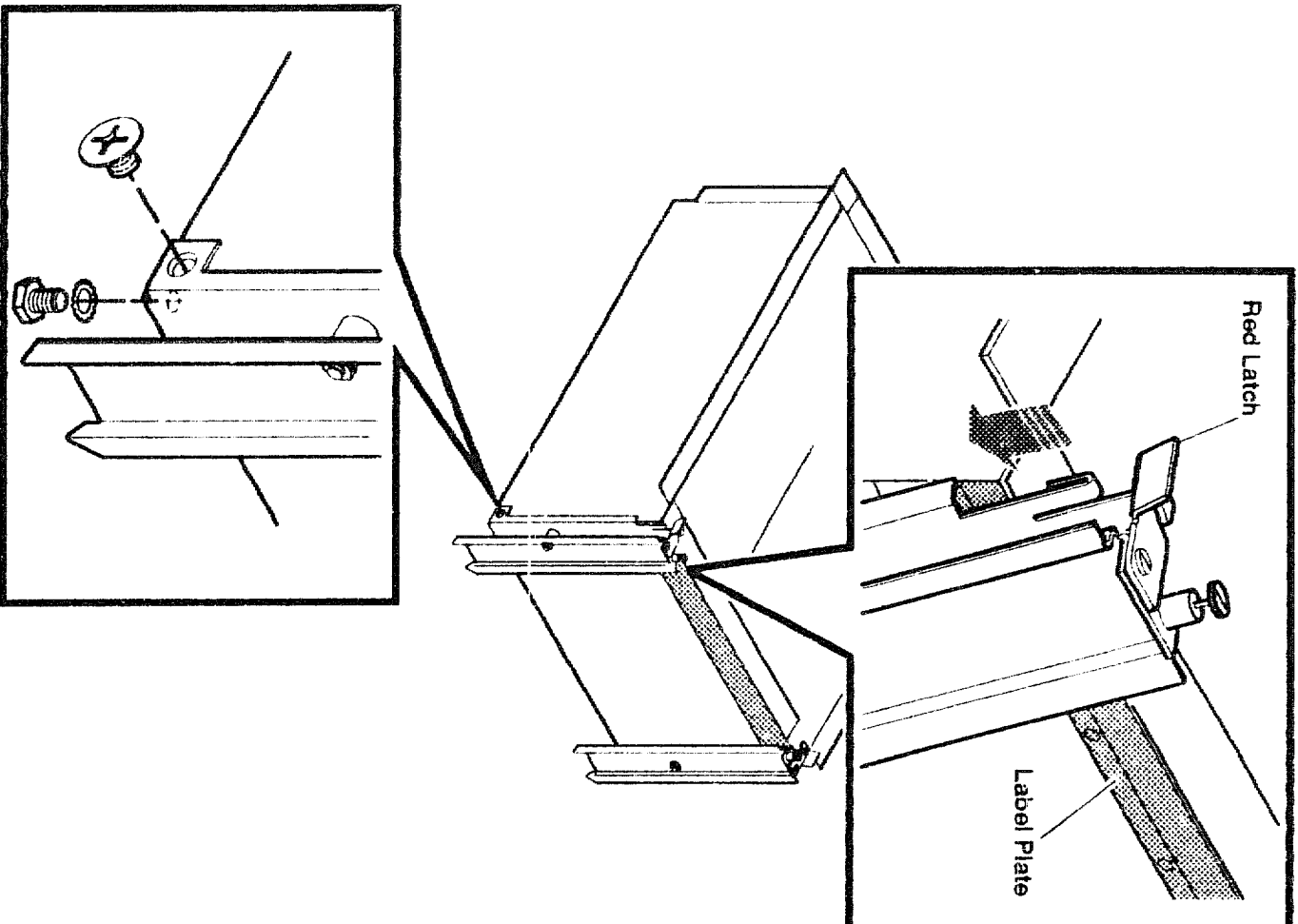
Attach the left and right ski assembly to the bottom of the chassis as follows (refer to Figure 15):

1. Place the chassis, back side down, on a sturdy table. Allow the bottom of the chassis to overhang by an inch or two.

**CAUTION:** *Handle the chassis with care to avoid damaging internal components.*

2. While attaching the left ski assembly to the chassis by clipping the ski onto the front of the enclosure, slide the regulatory label plate between the enclosure and ski assembly as shown in Figure 15.
3. Secure the ski as follows:
  - a. Use the Phillips flat-head screw at the countersunk hole on the side of the ski assembly (torque to 40 in · lbf).
  - b. Use a hex screw and lock washer at the rear of the ski assembly (torque to 40 in · lbf).
4. Ensure that the red latch on the front of the ski assembly is securely in place.
5. Attach the right ski assembly using the same procedure.

**Figure 15: Attaching Skis to Chassis**



MLC-006206

## 10 Install Chassis

Install the chassis as follows (refer to Figure 16):

1. One person should stand to the left of the chassis and one to the right. Both should lift the chassis and slide it into the cabinet. The ski assemblies should slide on top of the L-brackets.

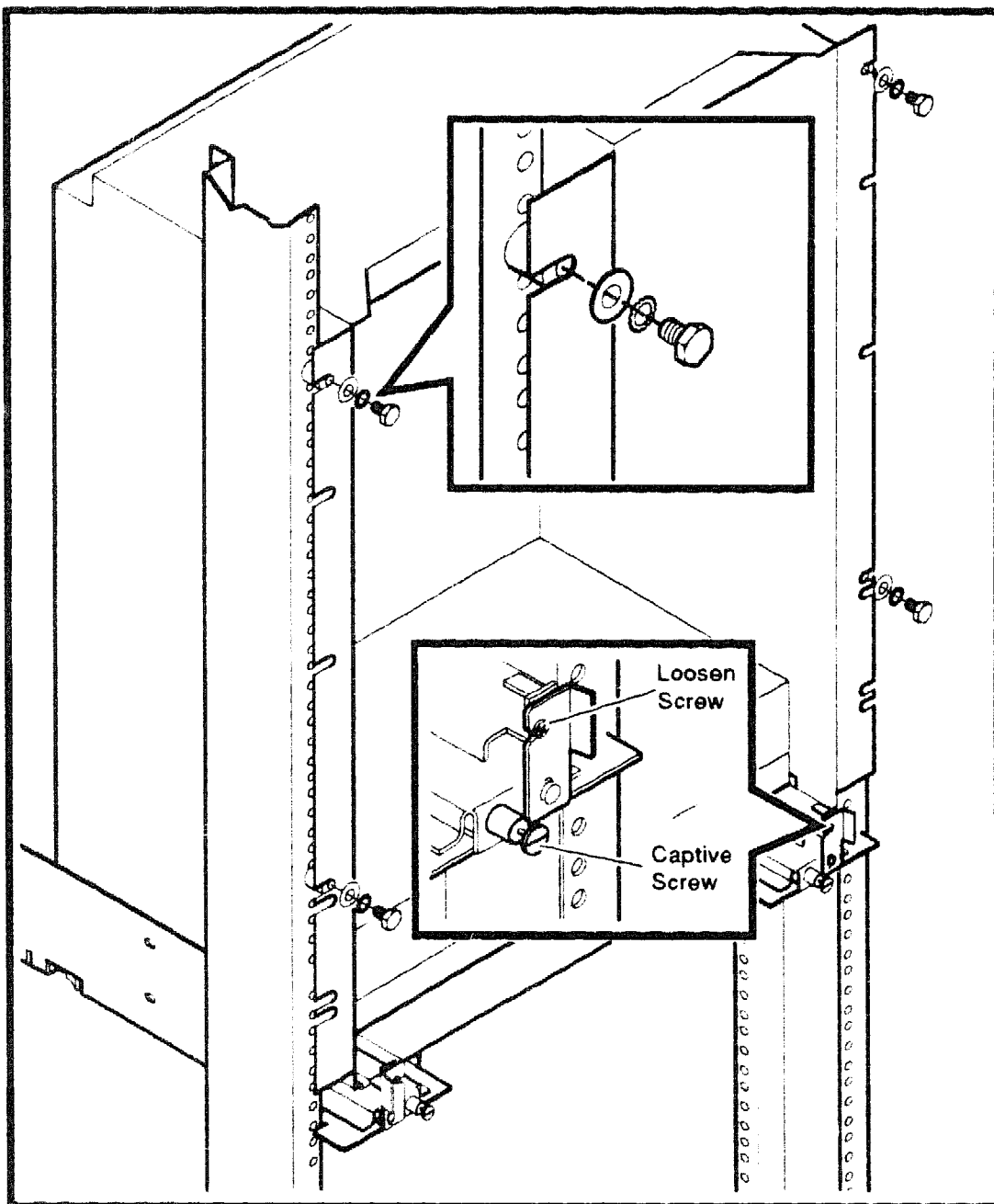
Push the chassis in until the ski assemblies reach their stops on the L-brackets.

**WARNING:** *One person should hold the chassis in place, as it is unstable in this position and will tip forward.*

2. Using hex screws, lock washers, and flat washers, secure the chassis (finger-tightened only) to the upper and lower isolators on the vertical rails.
3. Tighten the captive screw on each ski assembly.
4. Make certain that the chassis is centered between the vertical rails and that neither side of the chassis is touching the rails (Figure 17). You can use a flat-blade screwdriver as a lever between the vertical rails and chassis flange.
5. Tighten the four hex screws (torque the hex screws to 10 in · lbf).
6. Loosen the screw and release the red latch on each ski assembly. Tighten the screw so it will not fall out.

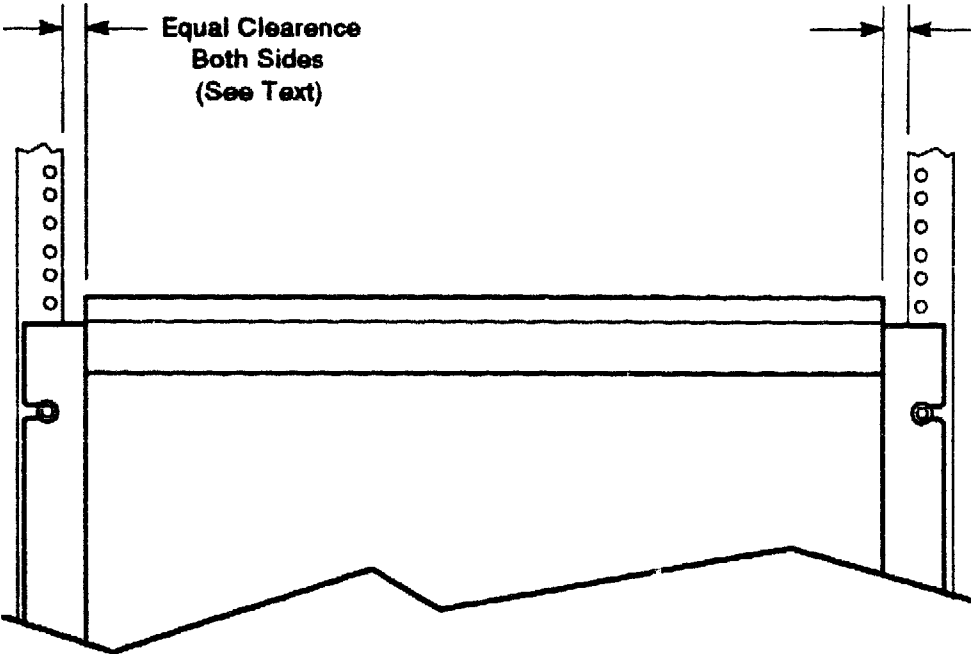


Figure 16: Installing the Chassis



MLO-006297

**Figure 17: Center Chassis Before Tightening Screws**



MLO-006298

**If you are preparing the cabinet for shipping, refer to Appendix A for instructions on mounting the shipping hardware.**

## Appendix A

# Attaching Shipping Hardware

---



The design of the BA400-series rackmount hardware requires the installation of special shipping hardware if the cabinet is to be shipped. The shipping hardware locks out the shock isolators and protects the isolators from the rigors of shipping.

**CAUTION:** *Shipping a rackmounted BA400-series chassis without installing the rackmount shipping hardware will destroy the isolators and can seriously damage system components.*

The shipping hardware consists of the following:

- Upper and lower shipping locks for the left and right vertical rails of the cabinet
- Two shipping plates, for the left and right side of the chassis

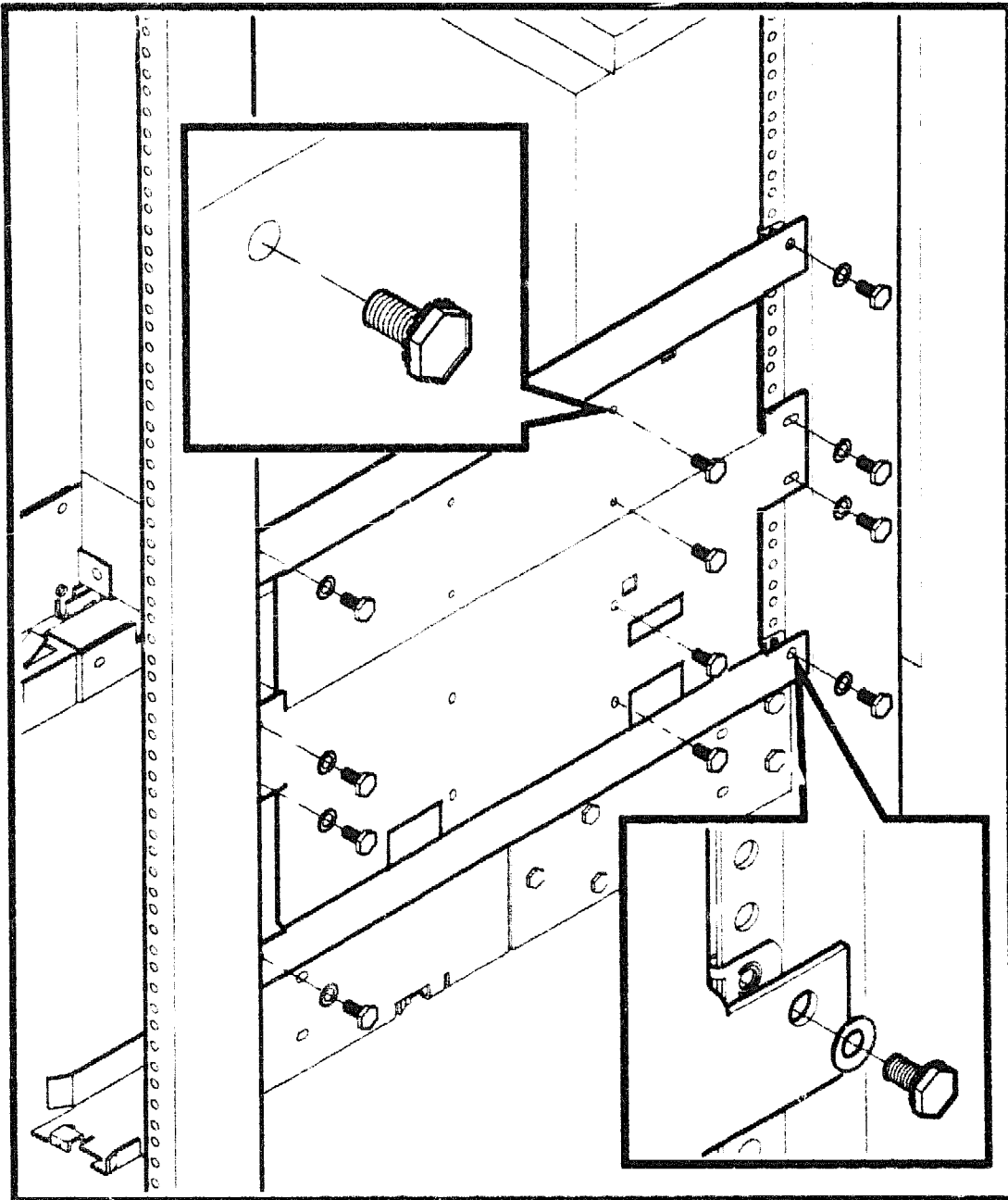
Use the instructions in this appendix for installing the shipping hardware.

### A.1 Installing the Shipping Plates

Install the left and right shipping plates as follows (refer to Figure A-1):

1. Attach one of the shipping plates to the side of the BA400 chassis using four of the 3/8 long hex screws with captive lock washers (finger tight only).
2. Secure the plates to the front and rear vertical rails using four more of the same screws and four flat washers for each rail.
3. Repeat the procedure for the second shipping plate.
4. Torque all 24 shipping plate screws to 20 in · lbf.

**Figure A-1: Installing the Shipping Plates**



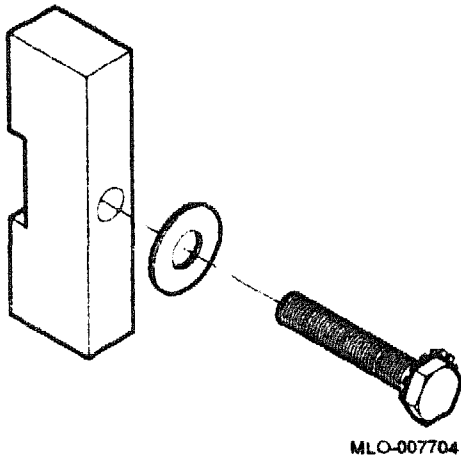
MLC-006299

## A.2 Installing the Shipping Locks

Install the upper and lower shipping locks as follows (refer to Figures A-2 and A-3):

1. Locate the four red shipping locks in the bag of shipping hardware.
2. Using the four 1-1/4 long hex screws, shipping locks, and flat washers, secure the chassis to the vertical rails.

**Figure A-2: Shipping Locks**

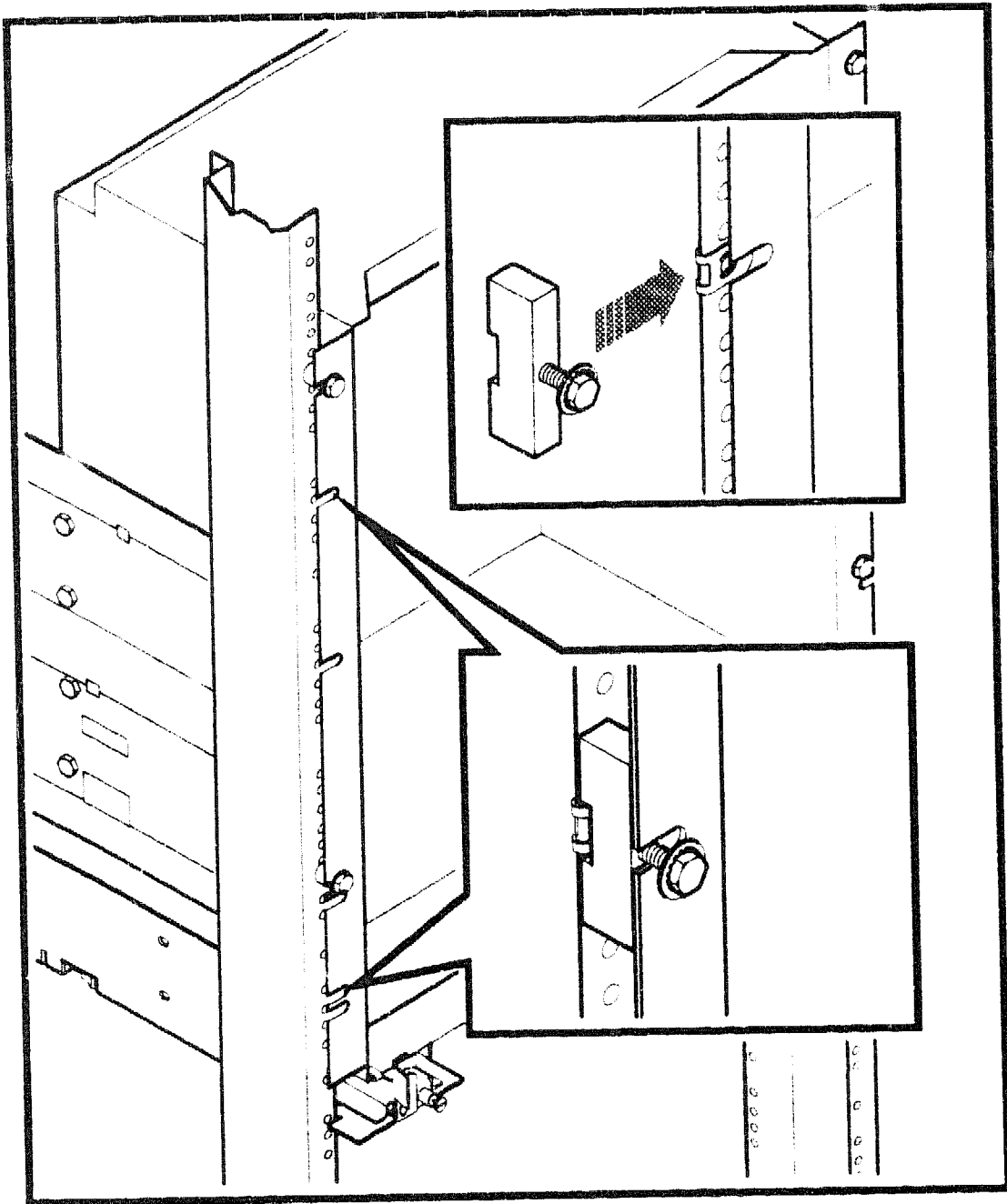


The shipping locks slide between the chassis flange and the vertical rail and attach to the clip-on u-nuts installed in Step 5 of this manual (torque the screws to 20 in · lbf).

The shipping hardware must be removed before operating the system.

**CAUTION:** *Operating a system with shipping hardware installed can damage drives.*

**Figure A-3: Installing the Shipping Locks**



MLO-006300