

AlphaServer 2100 CAB

Installation/Owner's Guide

Order Number: EK-ALCAB-OG. B01

1st Edition, December 1994
2nd Edition, April 1995

The information in this document is subject to change without notice and should not be construed as a commitment by Digital Equipment Corporation. Digital Equipment Corporation assumes no responsibility for any errors that may appear in this document.

Restricted Rights: Use, duplication, or disclosure by the U.S. Government is subject to restrictions set forth in subparagraph (c)(1)(ii) of the Rights in Technical Data and Computer Software Clause at DFARS 252.227-7013.

FCC NOTICE: This equipment has been tested and found to comply with the limits for a Class A digital device, pursuant to Part 15 of the FCC Rules. These limits are designed to provide reasonable protection against harmful interference when the equipment is operated in a commercial environment. This equipment generates, uses, and can radiate radio frequency energy and, if not installed and used in accordance with the instruction manual, may cause harmful interference to radio communications.

Any changes or modifications made to this equipment may void the user's authority to operate this equipment.

Operation of this equipment in a residential area may cause interference in which case the user at his own expense will be required to take whatever measures may be required to correct the interference.

© Digital Equipment Corporation 1994, 1995. All Rights Reserved.

Printed in U.S.A.

The postpaid Reader's Comments form at the end of this document requests your critical evaluation to assist in preparing future documentation.

The following are trademarks of Digital Equipment Corporation: AlphaServer, DEC, DECchip, Digital, OpenVMS, StorageWorks, ThinWire, VAX DOCUMENT, and the DIGITAL logo.

OSF/1 is a registered trademark of Open Software Foundation, Inc.
PostScript is a registered trademark of Adobe Systems Incorporated.
Microsoft is a registered trademark and Windows and Windows NT are trademarks of Microsoft Corporation.

All other trademarks and registered trademarks are the property of their respective owners.

S2847

This document was prepared using VAX DOCUMENT Version 2.1.

EC:

Warning! This is a Class A product. In a domestic environment this product may cause radio interference in which case the user may be required to take adequate measures.

Achtung! Dieses ist ein Gerät der Funkstörgrenzwertklasse A. In Wohnbereichen können bei Betrieb dieses Gerätes Rundfunkstörungen auftreten, in welchen Fällen der Benutzer für entsprechende Gegenmaßnahmen verantwortlich ist.

Attention! Ceci est un produit de Classe A. Dans un environnement domestique, ce produit risque de créer des interférences radioélectriques, il appartiendra alors à l'utilisateur de prendre les mesures spécifiques appropriées.

ACOUSTICS: Preliminary declared values per ISO 9296 and ISO 7779 (March 10, 1994):

	Sound Power Level L_{wAd}, B	Sound Pressure Level L_{pAm}, dBA (Bystander Positions)
Idle	6.4	52
Operating	6.4	52

Current values for specific configurations are available from Digital representatives. 1 B = 10 dBA.

SCHALLEMISSIONSWERTE: Verläufige Werteangaben nach ISO 9296 und ISO 7779/DIN EN27779 (10 March 1994):

	Schalleistungspegel L_{wAd}, B	Schalldruckpegel L_{pAm}, dBA (Zuschauerpositionen)
Leerlauf	6,4	52
Betrieb	6,4	52

Aktuelle Werte für spezielle Ausrüstungsstufen sind über die Digital Equipment Vertretungen erhältlich. 1 B = 10 dBA.

Contents

Preface	xiii
1 System Introduction	
In This Chapter	1-1
System Introduction and Features	1-2
Online Information	1-2
System Packaging	1-3
System Cabinet Specifications	1-5
System Characteristics	1-6
Components and Controls	1-8
Components: Front of System	1-8
Operator Control Panel	1-9
Operator Control Panel Door	1-10
Components: Top of System	1-11
Components: Left Side of System	1-12
Components: Rear of System	1-13
Components: Bottom of System	1-14
2 Site Preparation and Installation	
In This Chapter	2-1
Before Installing the System	2-2
Tools Required	2-2
Site Planning	2-3
Unpacking the System	2-7
Checking the Shipment	2-13
During System Installation	2-14
Removing and Replacing the Rear Door	2-14
Removing and Replacing the Front Door Latch Bracket	2-16
Removing and Replacing the Front Filler Panels	2-18
Adjusting the Stabilizer Bar	2-20
Using the Interlock System	2-22

Removing and Replacing the Front Bezel	2-24
Connecting the Terminal	2-26
Connecting to Networks	2-28
Overview	2-28
Ethernet	2-28
Connecting Peripherals	2-30
Serial/Parallel Connections	2-30
Expanding the System	2-32

3 System Operation

In This Chapter	3-1
Operator Control Panel	3-2
Turning the System On	3-5
Overview	3-5
Before You Begin	3-5
Checking the System Settings	3-6
Applying Power to the System	3-7
Displaying Power-Up Information	3-8
Checking the Diagnostic Indicators	3-8
Multiprocessor Failover	3-12
Preboot Tasks	3-14
Switching Between Operating Systems	3-17
Booting the Operating System	3-18
Autobooting the Operating System	3-19
Turning the System Off	3-20
Before You Begin	3-20
Turning Off the DC Power	3-20
Extended Power-Down (AC Power)	3-22
Invoking Console Mode	3-23
Console Subsystem	3-23
Console Terminal	3-23
Console Mode	3-23
Invoking Console Mode	3-23
Using the Halt Button	3-24
Remote Access	3-24
Operating Storage Devices	3-25
Overview	3-25
For Additional Information	3-25
Before You Operate Mass Storage Devices	3-25
Operating Storage Devices	3-25
Operating a CD-ROM Drive	3-26
CD-ROM Drive Description	3-26

Caddyless Drive	3-26
Drive with Caddy	3-28
Inserting and Removing a Compact Disc	3-30
Operating a DAT Tape Drive	3-34
DAT Description	3-34
Inserting a Tape	3-34
Removing a Tape	3-34
Operating a Diskette Drive	3-36
Diskette Drive Description	3-36
Inserting a Diskette	3-36
Removing a Diskette	3-36
Operating a QIC Drive	3-38
QIC Drive Description	3-38
Inserting a QIC Tape	3-38
Removing a QIC Tape	3-38

4 Options and Upgrades

In This Chapter	4-1
Upgrade Overview	4-2
Planning Your Upgrade	4-2
Supported Options	4-4
Supported Options	4-4
Access from the Internet	4-4
Access from CompuServe	4-4
Digital Systems and Options Catalog	4-4
Verifying System Configuration	4-5
Before You Begin	4-5
Firmware Menu Options for Windows NT	4-5
Firmware Console Commands for DEC OSF/1 and OpenVMS	4-5
System Bus Options	4-7
CPU Modules	4-8
Memory Modules	4-9
Expansion I/O (64-Bit PCI) Module	4-9
Guidelines for Systems with SWXCR-Ex Controller	4-10
Standard I/O Module	4-11
EISA Bus Options	4-12
ISA Bus Options	4-13
Identifying EISA and ISA Options	4-14
Configuring EISA and ISA Options	4-15
EISA Configuration Utility	4-15
System Configuration Diskette	4-15

Before Running the ECU	4-16
Starting the ECU	4-17
Configuring EISA Options	4-19
Configuring EISA/ISA Options	4-21
PCI Bus Options	4-23
SCSI Buses	4-25
Internal SCSI Bus	4-25
Installing Removable Media Storage Devices	4-26
Installing a Hard-Disk Drive	4-28
Power Supply Configurations	4-30
Console Port Configurations	4-32

5 System Troubleshooting

In This Chapter	5-1
Determining the Service Provider	5-2
Determine the Service Provider	5-2
Considerations Before Troubleshooting	5-2
Identifying Problems	5-3
Task Overview	5-4
Identifying and Resolving Problems	5-4
Determining the Type of Problem	5-5
Types of System Problems	5-5
Reporting Problems	5-6
Precall Checklist	5-6
Digital Support Center Contact Numbers	5-6
Power Problems	5-10
Problems Getting to Console Mode	5-11
Interpreting the Operator Control Panel Power-Up/Diagnostic Display	5-12
Failing SIMMs Reported on Power-Up Display	5-13
Console Reported Problems	5-16
show fru	5-17
test	5-19
Mass-Storage Problems Indicated at Power-Up	5-21
EISA Bus Problems Indicated at Power-Up	5-25
Additional EISA Troubleshooting Tips	5-27
PCI Bus Problems Indicated at Power-Up	5-28
Boot Problems	5-29
Operating System Reported Problems	5-30
Fail-Safe Loader	5-31
Fail-Safe Loader Functions	5-32
Activating the Fail-Safe Loader	5-32

Index

Figures

1-1	AlphaServer 2100 CAB system Chassis	1-3
1-2	Full Complement System Cabinet	1-4
1-3	Front Components	1-8
1-4	Operator Control Panel	1-9
1-5	Unlocking the Operator Control Panel Door	1-10
1-6	Top Components	1-11
1-7	Left-Side Components	1-12
1-8	Rear Components	1-13
1-9	Bottom Access Door	1-14
2-1	System Clearance and Service Area	2-6
2-2	Unpacking the System Cabinet	2-8
2-3	Installing the Ramps	2-10
2-4	Removing the Cabinet from the Skid	2-12
2-5	Removing and Replacing the Rear Door	2-15
2-6	Removing and Replacing the Front Door Latch Bracket	2-17
2-7	Removing and Replacing the Front Filler Panels	2-19
2-8	Pulling Out and Adjusting the Stabilizer Bar	2-21
2-9	The Interlock System	2-23
2-10	Removing and Replacing the Front Bezel	2-25
2-11	Connecting the Terminal	2-27
2-12	Ethernet Network Connections	2-29
2-13	Connecting Serial and Parallel Devices	2-31
2-14	SCSI Expansion and Optional RAID and/or DSSI Ports	2-33
3-1	Operator Control Panel	3-2
3-2	Powered-Down System Settings	3-6
3-3	Applying Power to the System	3-7
3-4	Turning Off the System	3-21
3-5	Turning Off the AC Power	3-22
3-6	Caddyless CD-ROM Drive	3-27
3-7	CD-ROM Drive with Caddy	3-29
3-8	Inserting and Removing a Caddyless Compact Disc	3-31
3-9	Inserting and Removing a CD-ROM Caddy	3-33
3-10	Inserting and Removing a Tape: DAT	3-35

3-11	Diskette Drive and Diskette	3-37
3-12	QIC Tape Drive and QIC Tape	3-39
4-1	System Bus Option Locations	4-7
4-2	System Bus Configurations According to the Number of CPUs	4-8
4-3	EISA and ISA Boards	4-14
4-4	PCI Board	4-24
4-5	Installing Removable Media	4-27
4-6	Installing a Hard-Disk Drive	4-29
4-7	Power Supply Configurations	4-31
5-1	Fail-Safe Loader Jumper (J6) on the Standard I/O Module	5-33

Tables

1-1	System Cabinet Specifications	1-5
1-2	System Characteristics	1-6
2-1	System Electrical Specifications (60 Hz)	2-3
2-2	System Electrical Specifications (50 Hz)	2-4
2-3	System Environmental Conditions	2-5
3-1	Interpreting Operator Control Panel Power-Up Display	3-13
3-2	Setting No Autoboot	3-15
4-1	RAID Subsystem Documentation	4-10
4-2	Summary of Procedure for Configuring EISA Bus (EISA Options Only)	4-20
4-3	Summary of Procedure for Configuring EISA Bus with ISA Options	4-22
5-1	How to Identify a Problem	5-3
5-2	Identifying and Resolving Problems	5-4
5-3	Problem Reference	5-5
5-4	Digital Support Centers	5-7
5-5	Diagnostic Flow for Power Problems	5-10
5-6	Diagnostic Flow for Problems Getting to Console Mode	5-11
5-7	Interpreting the Operator Control Panel Power-Up/Diagnostic Display	5-12
5-8	Memory Data Bits in Error and Corresponding SIMM Position	5-14

5-9	Diagnostic Flow for Problems Reported by the Console Program	5-16
5-10	Fixed-Media Mass-Storage Problems	5-22
5-11	Removable-Media Mass-Storage Problems	5-23
5-12	Troubleshooting RAID Problems	5-24
5-13	EISA Troubleshooting	5-26
5-14	PCI Troubleshooting	5-28
5-15	Diagnostic Flow for Boot Problems	5-29
5-16	Diagnostic Flow for Errors Reported by the Operating System	5-30

Preface

Purpose of This Guide

This guide together with the *AlphaServer 2000/2100 Firmware Reference Guide* describe how to install, operate, upgrade, and troubleshoot the AlphaServer 2100 CAB system.

Who Should Use This Guide

This guide is for Digital service personnel or qualified self-maintenance customers who are familiar with computer installation tasks, and for system managers and others who perform system management tasks.

Structure of This Guide

This guide is organized in the following manner:

- Chapter 1, System Introduction—Introduces the system, and its functional characteristics, components, and controls.
- Chapter 2, Site Preparation and Installation—Provides site planning and preparation information, as well as system unpacking and installation procedures.
- Chapter 3, System Operation—Describes the operator control panel and provides procedures for power on and off, checking indicators, switching between consoles, and booting the operating system.
- Chapter 4, Options and Upgrades—Describes the options and upgrades and provides procedures for verifying the system configuration and configuring system options.
- Chapter 5, System Troubleshooting—Provides information and procedures for diagnosing and correcting system and peripheral problems.

Related Documents

Other documents related to the AlphaServer 2100 CAB system include the following:

- *AlphaServer 2100 RM Series Installation / Owner's Guide* (EK-KN450-RM)
- *H9A10 (600 mm) Cabinet Installation / Owner's Guide* (EK-HA910-IN)
- *AlphaServer 2000 / 2100 Firmware Reference Guide* (EK-AXPFW-RM)
- *AlphaServer 2000 / 2100 / 2100R / 2200 Server Windows NT Release Notes* (EK-WNTFS-IN)
- *DSSI VMScluster Installation and Troubleshooting* (EK-D4AXP-TS)
- *AlphaServer 2000 / 2100 / 2100 RM / 2100 CAB Series Service Guide* (EK-KN450-SV)
- *OpenVMS AXP System Dump Analyzer Utility Manual* (AA-PV6UB-TE)
- *Guide to Kernel Debugging* (AA-PS2TA-TE)
- *DEC Verifier and Exerciser Tool User's Guide* (AA-PTTMA-TE)

Conventions Used in This Guide

This guide uses the following conventions:

Convention	Meaning
Note	A note calls the reader's attention to any item of information that may be of special importance.
Caution	A caution contains information essential to avoid damage to the equipment.
Warning	A warning contains information essential to the safety of personnel.

Convention	Meaning
❶ ❷ ❸ . . .	Numbered callouts are used to label and refer to parts of a figure.
MONOSPACE	Text displayed on the screen is shown in monospace type.
MONOSPACE	Bold type denotes user input.
<i>italic type</i>	Italic type emphasizes important information, indicates variables, and indicates complete titles of manuals.
<i>n.nn</i>	A period in numerals signals the decimal point indicator. For example, <i>1.75</i> equals <i>one and three-fourths</i> .
Ctrl/x	Ctrl/x indicates that you hold down the Ctrl key while you press another key or mouse button (indicated here by <i>x</i>).
Return	Specific keys such as the Return key are represented in boxes.
<i>x</i>	A lowercase italic <i>x</i> indicates the generic use of a letter. For example, <i>xxx</i> indicates any combination of three alphabetic characters.
<i>n</i>	A lowercase italic <i>n</i> indicates the generic use of a number. For example, <i>19nn</i> indicates a 4-digit number in which the last 2 digits are unknown.
[]	In command format descriptions, brackets indicate optional elements. You can choose none, one or more, or all of the options.
console command abbreviations	Console command abbreviations must be entered exactly as shown.
boot	Console and operating commands are shown in this special typeface.

Safety Symbols

The following symbols appear on the system. Please review their definitions below:



Warning: For protection against fire, use only modules with current-limiting outputs.



Warning: CPU and memory modules have parts that operate at high temperatures. Wait two minutes after power is removed before handling these modules.



Warning: This area contains electrical energy. Disconnect the AC power cord(s) to the system before accessing this area.



Warning: High voltage shock hazard present inside the power supply.

1

System Introduction

In This Chapter

This chapter covers the following topics:

- System Introduction and Features
- Power Cord Order Numbers
- System Cabinet Specifications
- System Characteristics
- Components and Controls

System Introduction and Features

The AlphaServer 2100 CAB system is a member of the AlphaServer product line. The product line is a family of symmetric multiprocessing, server systems. Supported by multiple operating systems (currently DEC OSF/1, OpenVMS, and Windows NT), they are suitable for several computing environments: general purpose computing, high-performance applications and databases, and PC LAN servers.

The server CPU is based on the DECchip 20164 processor chip. Successive upgradable generations are planned.

The AlphaServer 2100 CAB system is designed for office or satellite equipment room installations where floor space is at a premium, but large disk storage arrays and/or other expansion is required. The system may also be used in laboratory or factory environments where rackmount application-specific equipment must be configured with the system.

Online Information

Your system shipment includes a set of diskettes called the "Fast Track to Information." Fast Track is an easy-to-navigate, electronic version of the user information for the AlphaServer 2100 systems.

You can install Fast Track on any personal computer or laptop computer running Microsoft Windows V3.1 or later or a Windows emulator. You need to have approximately four megabytes available on your designated disk.

Note

Future plans call for Fast Track to Information to be shipped on CD-ROM with new systems.

Figure 1–1 AlphaServer 2100 CAB system Chassis

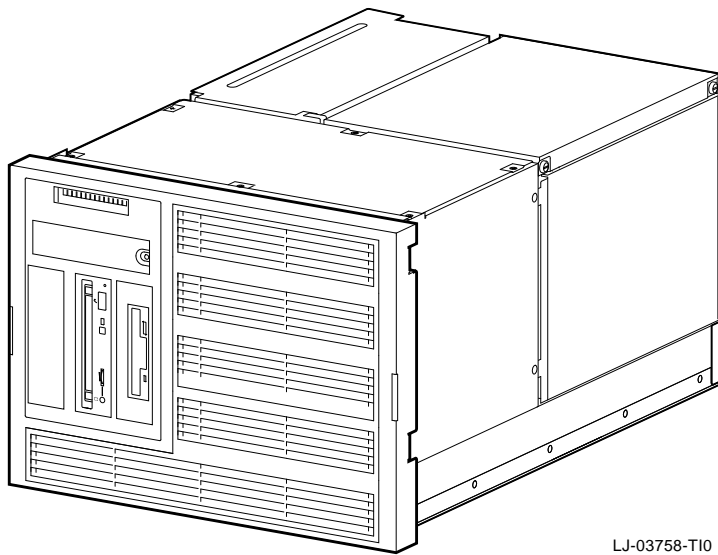

LJ-03758-T10

System Packaging

The system is packaged in a standard slide-mounted chassis (see Figure 1–1), and installed in an H9A10 cabinet (see Figure 1–2). The H9A10 is a low-cost cabinet that meets the Electronic Industries Association (EIA), and the International Electrotechnical Commission (IEC) 297 standards.

Two power controllers or power distribution units and their power cords are shipped with each AlphaServer 2100 CAB system. The power cords have either: 5-30P plugs for 120-Vac operation, or 6-20P (PDU) or 6-30P (power controller) plugs for 240-Vac operation in the U.S.A., Canada, and Japan. If the plugs are not compatible to your power-source receptacle, contact your Digital Customer Service office for assistance.

Note

The equipment installed must have an interlock bracket to work with the interlock kit.

System Introduction and Features

Figure 1–2 Full Complement System Cabinet

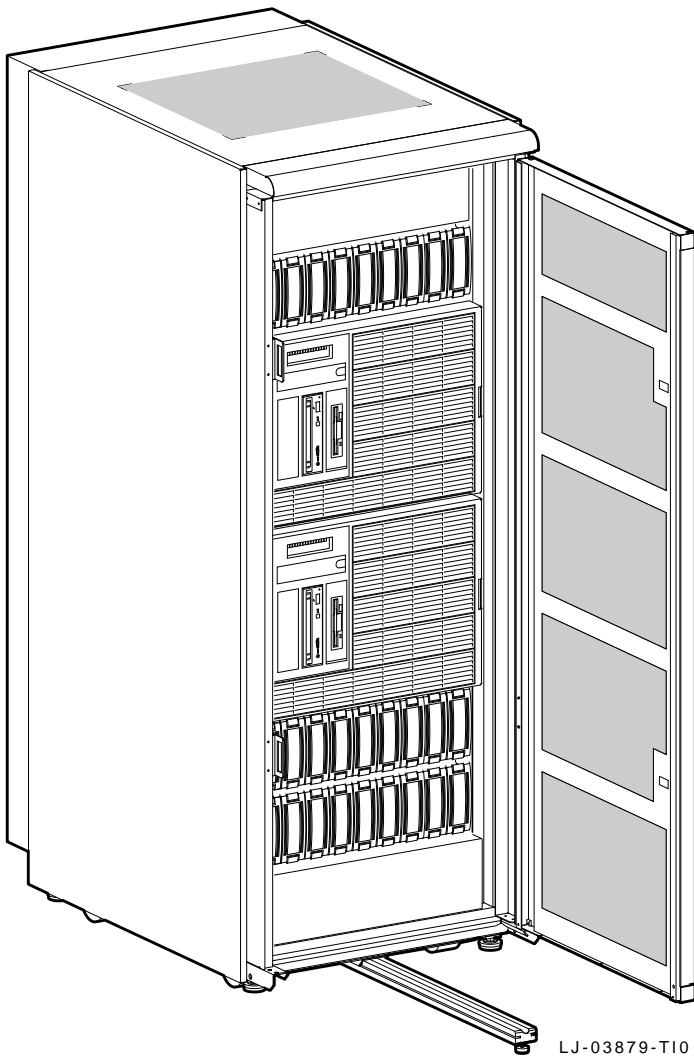

System Cabinet Specifications

The system cabinet specifications are contained in Table 1–1.

Table 1–1 System Cabinet Specifications

Item	Specification
Operating Specifications:	
Height	170.0 cm (66.9 in)
Width	60.0 cm (23.6 in)
Depth	87.5 cm (34.0 in)
Weight	286 kg (630 lb)
Shipping Specifications:	
Height	181.4 cm (71.4 in)
Width	91.4 cm (36.0 in)
Depth	121.6 cm (47.9 in)
Weight	318 kg (700 lb)
Maximum vertical rackmounting space (with power controllers installed)	153.5 cm (metric RETMA) ¹ 54.25 in (English RETMA) ²
Horizontal rack width	Standard 48.26-cm (19-in.) EIA rail spacing ³
Casters, swivel, nonlocking:	
Diameter	7.62 cm (3 in.)
Maximum capacity	225 kg (500 lb)
Casters, fixed, nonlocking:	
Diameter	7.62 cm (3 in.)
Maximum capacity	225 kg (500 lb)

¹Refers to the cabinet version that has the rail-hole pattern compliant with the metric Radio Electronic Television Manufactures Association (RETMA) standard

²Refers to the cabinet version that has the rail-hole pattern compliant with the English RETMA standard

³Depending on the cabinet model ordered, the rail-hole pattern may be compliant with either the English RETMA or the metric RETMA standard.

System Characteristics

Table 1–2 highlights the system characteristics of the AlphaServer 2100 CAB system.

Table 1–2 System Characteristics

Characteristic	Description
Four-processor capability	Systems can be configured as a uniprocessor or with up to four processors.
High-performance PCI I/O subsystem	Peripheral Component Interconnect (PCI) is an industry-standard bus that supports Digital and third-party options. The current PCI implementation on the server has a peak bandwidth of 132 MB/s.
EISA I/O bus	33 MB/s EISA I/O bus supports the industry-standard EISA options, such as: Network adapters Video/audio options Storage adapters
Internal mass storage	Accommodates up to two, 13.3-cm (5.25-in) half-height hard-disk-drive storage devices. One device is standard in all configurations and a second is optional. Up to 2 GB per drive.
External storage devices	Supports external StorageWorks compatible storage devices for low-cost, high-capacity, flexible configurations. This capability allows many independent disks that may be configured in stripe sets, shadow sets, or RAID sets to optimize performance according to customer requirements.

(continued on next page)

Table 1–2 (Cont.) System Characteristics

Characteristic	Description
High availability	Supports disk hot swap in external StorageWorks shelves as well as clustering (currently, only for OpenVMS) with proper software and controllers.
CPU chip technology	The DECchip 21064, 21064A, and 21065, which offer successively higher levels of performance, are manufactured using Digital's CMOS process. This process uses a feature size of 0.75 micron, and the chip contains 1.7 million transistors on one die.
CPU clock rate	200 MHz initially; >300 MHz over lifetime.
CPU chip design features	Superscalar, superpipelined
System bus bandwidth	667 MB/s (128-bit, 24-ns cycle)
Memory	Up to 2 GB of main memory

Components and Controls

Components: Front of System

Figure 1-3 shows the components on the front of the system.

Figure 1-3 Front Components

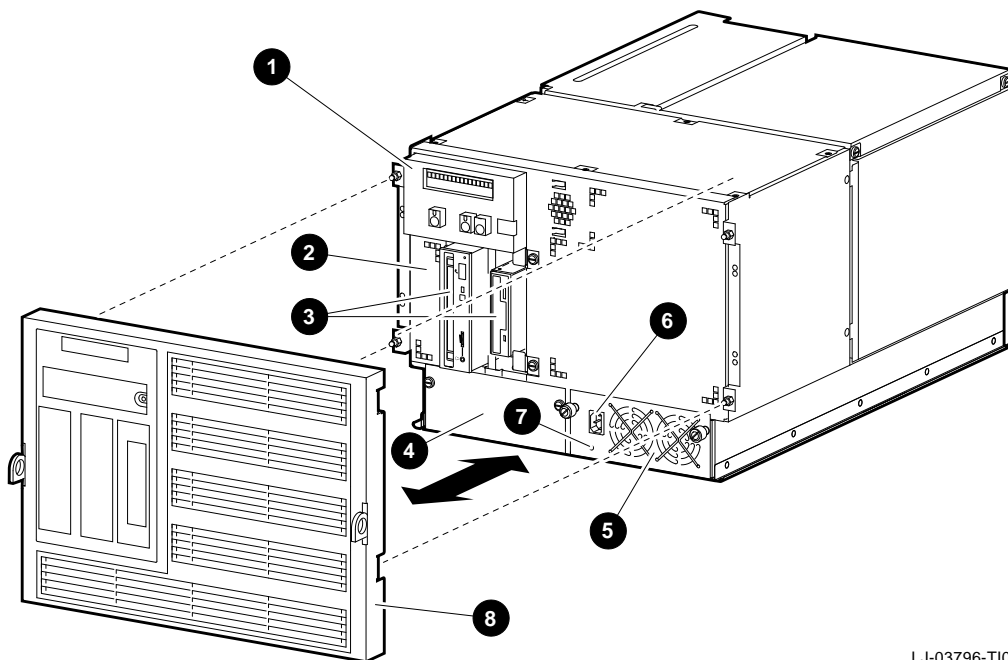

LJ-03796-T10

- | | |
|--|---|
| ① Operator control panel | ④ Location for optional redundant power supply |
| ② Optional slot for removable-media mass-storage devices | ⑤ Power supply |
| ③ Removable-media mass-storage devices | ⑥ Power connector, AC (the system does not have an AC power switch) |
| | ⑦ Power supply DC Okay indicator |
| | ⑧ Front bezel |

For information about mass-storage controls, refer to device-specific information in Chapter 4 of this guide.

Operator Control Panel

Figure 1-4 shows the individual controls and indicators on the operator control panel.

Figure 1-4 Operator Control Panel

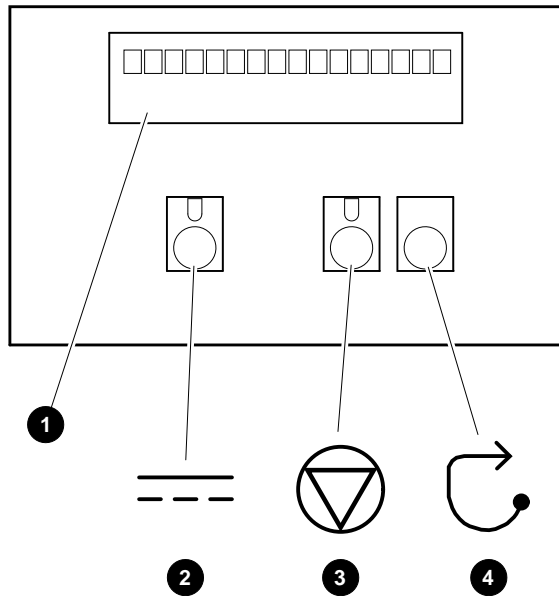

LJ-03778-T10

- ❶ Power-up/diagnostic display
- ❷ DC On/Off button
- ❸ Halt button (DEC OSF/1 and OpenVMS systems only)
- ❹ Reset button

Components and Controls

Operator Control Panel Door

The operator control panel door allows access to the controls without removing the front bezel. To open the door, unlock the door ❶ and pull the upper-right edge ❷ of the door away from the system as shown in Figure 1-5.

Figure 1-5 Unlocking the Operator Control Panel Door

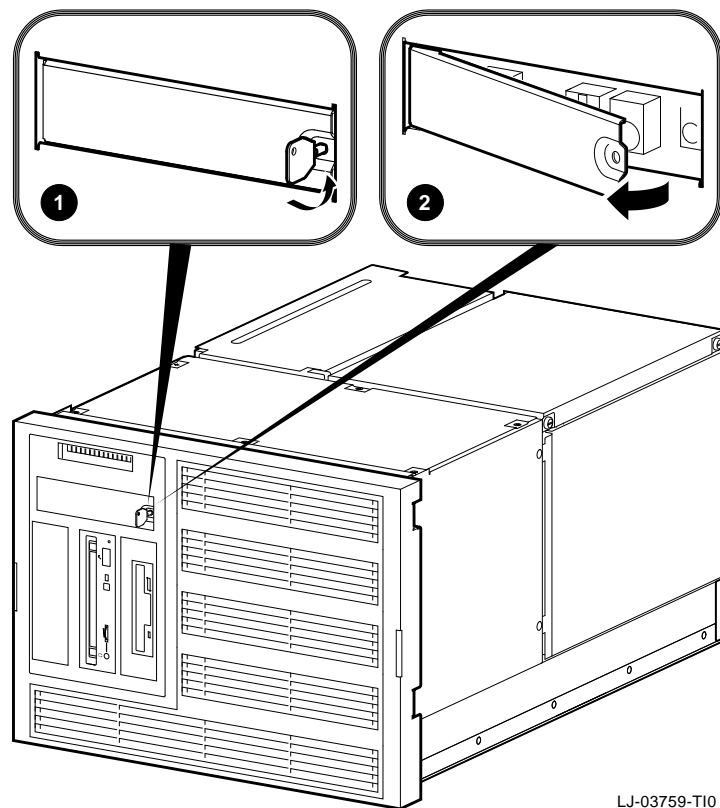

LJ-03759-T10

**Components:
Top of System**

Figure 1–6 shows the location of the top-rear access cover to the module card-cage area and the top-front access cover to the area containing the fan assembly, removable-media mass-storage device, and fixed-media mass-storage device(s).



Warning: CPU and memory modules have parts that operate at high temperatures. Wait two minutes after power is removed before handling these modules.

Figure 1–6 Top Components

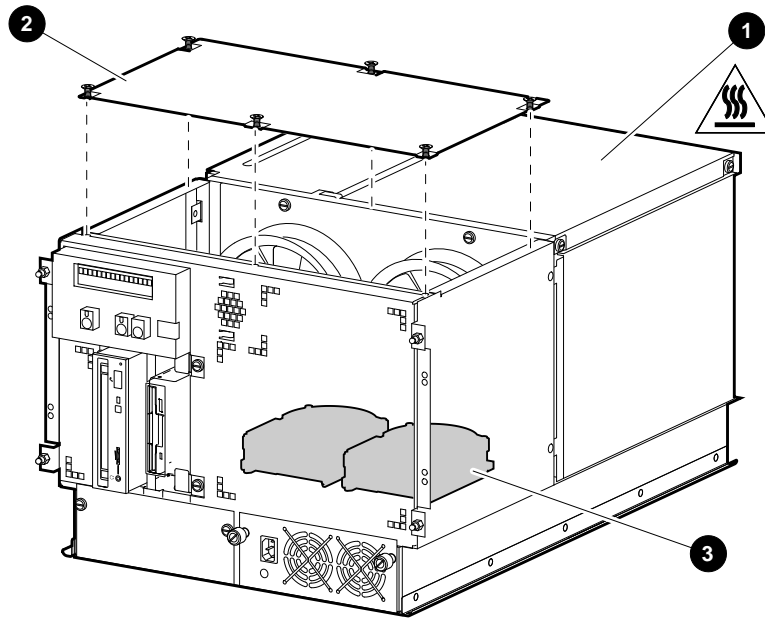

LJ-03797-T10

- ❶ Top-rear access cover
- ❷ Top-front access cover

- ❸ Fixed-media mass-storage device (second device is optional)

Components and Controls

Components: Left Side of System

Figure 1-7 shows how to access the PCI and EISA input/output (I/O) interface boards through the left-side access door.



Warning: For protection against fire, use only modules with current-limited outputs.

Figure 1-7 Left-Side Components

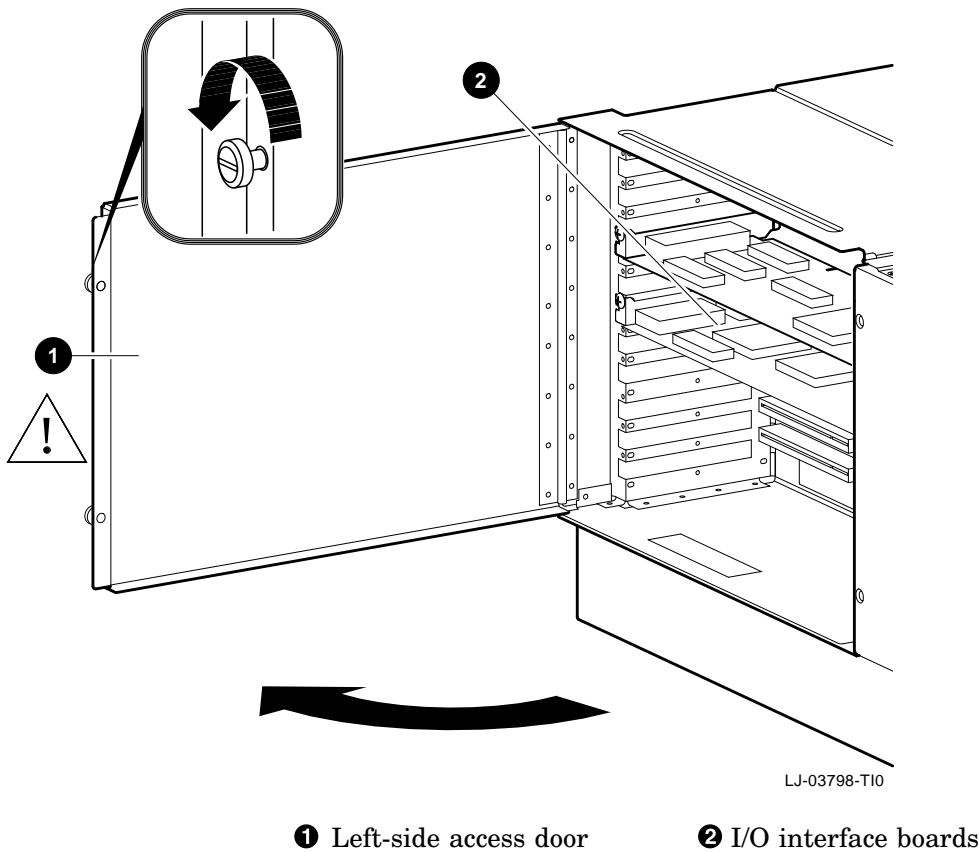

**Components:
Rear of System**

Figure 1-8 shows the major components at the rear of the system.

Figure 1-8 Rear Components

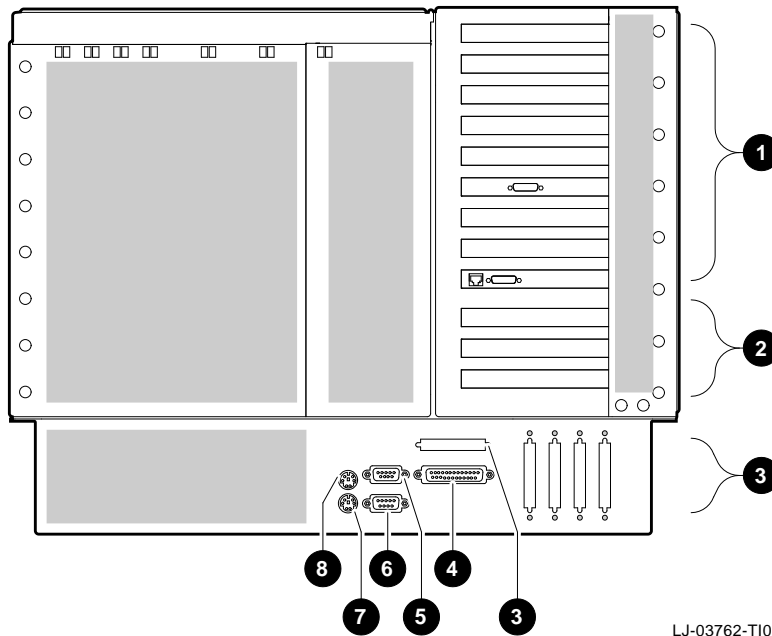

- ❶ EISA board bulkhead
- ❷ PCI board bulkhead
- ❸ SCSI and DSSI expansion ports
- ❹ Parallel port
- ❺ Serial port (COM1)
- ❻ Serial port (COM2)
- ❼ Mouse port
- ❽ Keyboard port

Components and Controls

Components: Bottom of System

Figure 1-9 shows the bottom access door. This door provides service access to the power supply connections and the SCSI, parallel, serial (COM1 and COM2), mouse, and keyboard ports.



Warning: This area contains electrical energy. Disconnect the AC power cord(s) to the system before accessing this area.

Figure 1-9 Bottom Access Door

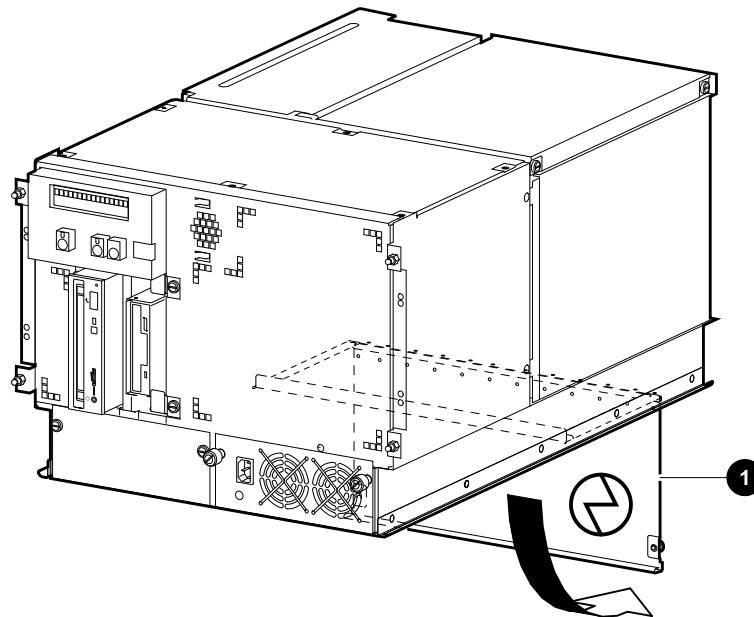

LJ-03799-T10

❶ Bottom access door

2

Site Preparation and Installation

In This Chapter

This chapter covers the following topics:

- Before Installing the System
- Site Planning
- Unpacking the System
- During System Installation
- Connecting to Networks
- Connecting Peripherals

Before Installing the System

Warning

Only qualified service persons should install the system. Qualified service persons need not be Digital Services representatives, but they should have the technical training and experience:

- To be aware of hazards to which they are exposed in performing a task
 - To take measures to minimize danger to themselves or other persons.
-

Tools Required

The tools required to unpack and install the system are:

- Scissors
- Flat-blade screwdriver
- Phillips screwdriver
- Adjustable wrench
- Spirit level

Site Planning

The installation instructions that follow assume that:

- All cables that you plan to connect to your system are in place and clearly labeled. These cables are:
 - Terminal data cables
 - Telephone cables
 - Network cables
- The requirements and conditions listed Table 2–1, Table 2–2, and Table 2–3 have been satisfied
- The system is located in an area that provides sufficient clearance for ventilation and servicing. Figure 2–1 shows the recommended clearance and service area required for the system.

Table 2–1 System Electrical Specifications (60 Hz)

Requirement	Specification
Input voltage	120 Vac nominal
Operational voltage range	90-132 Vac
Phasing	Single-phase
Frequency range	57-63 Hz, 60 Hz nominal
Input current	8 A typical, 16 A maximum, per power cord
Ground current	2.3 mA typical
Power consumption	1400 W typical, 3450 W maximum
U.S.A. power cord plug (3 pole, 3 wire)	NEMA L5-30P (Mates with receptacle NEMA L5-30R)

Two power controllers or power distribution units rated at 24 A for 120 Vac are supplied with the system.

Table 2–2 System Electrical Specifications (50 Hz)

Requirement	Specification
Input voltage	220-240 Vac nominal
Operational voltage range	180-256 Vac
Phasing	Single-phase
Frequency range	47-53 Hz, 50 Hz nominal
Input current	4 A typical, 8 A maximum, per power cord
Ground current	4.4 mA typical
Power consumption	1440 W typical, 3450 W maximum
UK power cord plug (3 pole, 3 wire)	NEMA L6-20P or L6-30P (Mates with receptacle NEMA L6-20R or L6-30R)

Two power controllers or power distribution units rated at 16 A for 220 Vac are supplied with the system.

Warning

High Leakage Current — An insulated earthing conductor that is identical in size, insulation material, and thickness to the earthed and unearthed branch-circuit supply conductors (except that it is green with or without one or more yellow stripes) is to be installed as part of the branch circuit that supplies the system. The earthing conductor described is to be connected to earth at the service equipment or, if supplied by a separately derived system, at the supply transformer or motor-generator set.

The attachment-plug receptacles in the vicinity of the system are all to be of an earthing type, and the earthing conductors serving these receptacles are to be connected to earth at the service equipment.

Table 2–3 System Environmental Conditions

Conditions	Specifications
Temperature range:	
Operating	10°C to 35°C (50°F to 95°F)
Nonoperating	-40°C to 66°C (-40°F to 151°F)
Storage (60 days)	-40°C to 66°C (-40°F to 151°F)
Rate of change	11°C/hr (20°F/hr)
Relative humidity:	
Operating	10-90% noncondensing
Nonoperating	10-90% noncondensing
Storage	10-90% noncondensing
Storage (60 days)	10-90% noncondensing
Rate of change	20%/hr
Maximum heat dissipation	3450 W AC, 11,730 BTU/hr
Air flow:	
Operating	400 CFM
Intake location	Cabinet front
Exhaust location	Cabinet rear top
Altitude:	
Operating	2000 m (6,562 ft)
Nonoperating	3600 m (12,000 ft)

Caution

Do not impede airflow by obstructing the front and rear of the unit. Exceeding internal thermal limits can affect system reliability/availability.

Figure 2-1 System Clearance and Service Area

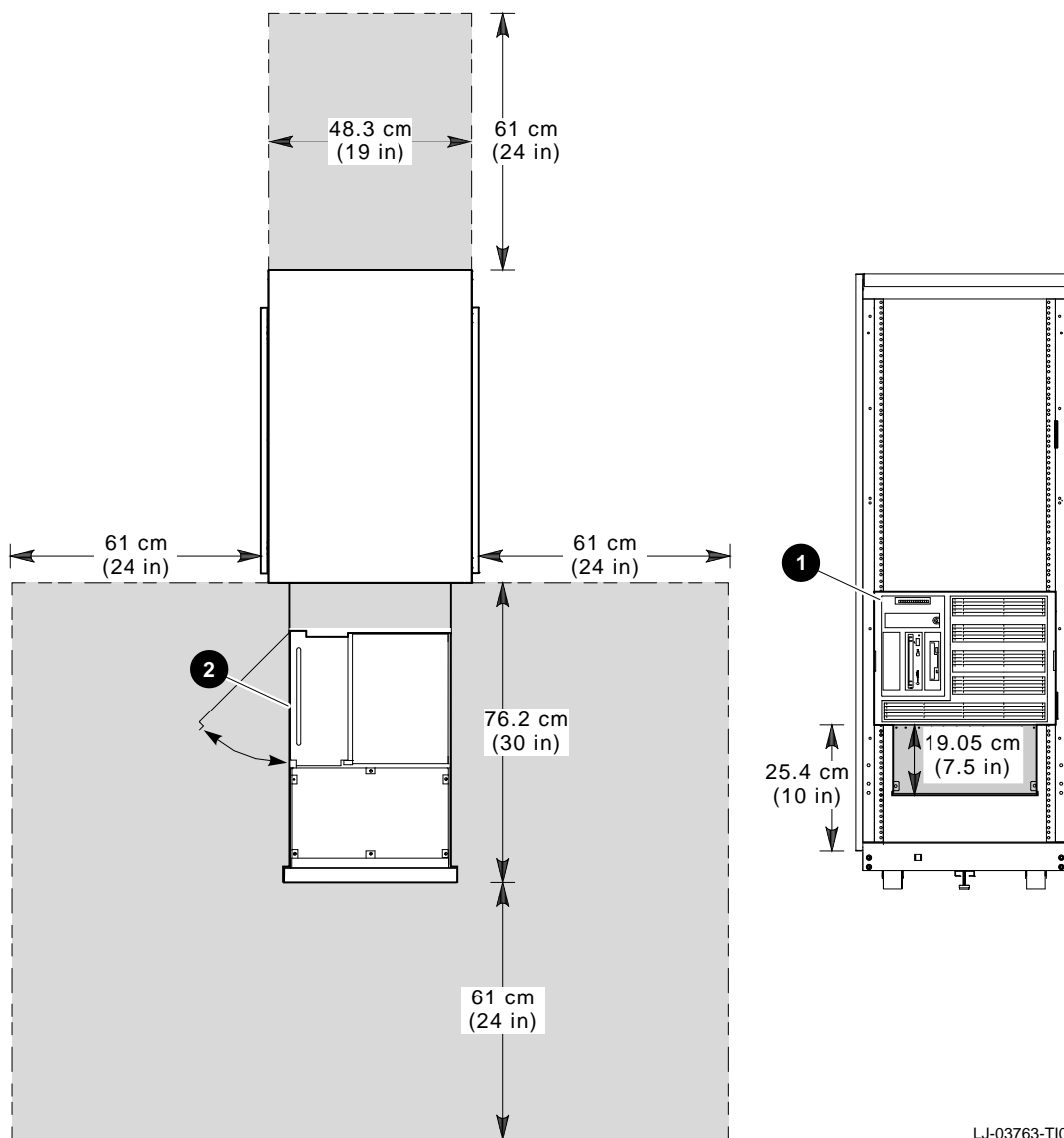

LJ-03763-T10

- ❶ Front bezel
- ❷ AlphaServer 2100 PCI/EISA compartment

Unpacking the System

The cabinet is shipped on a wooden pallet. Use the following procedure to unpack the cabinet.

1. Position the pallet in an area that provides sufficient workspace for unpacking. Ensure that there is sufficient clearance in front of the pallet (marked with a large F) to roll the cabinet down the ramps.
2. Refer to Figure 2–2. Cut and remove the plastic wrapping ❶ that secures the corner posts ❷ and the carton ❸ to the cabinet. The carton contains the two ramps.
3. Remove the corner posts ❷ and the carton ❸ from the pallet ❹.

Caution

In the next step, take care not to damage the cabinet finish when removing the shrinkwrap.

4. Remove the plastic bag ❺ covering the cabinet.
5. Check the cabinet and the associated equipment for any external damage. Report any damage to your service representative or a Digital sales office and to the responsible freight carrier.

Note

Keep all packing material and receipts in the event a damage claim is filed.

Unpacking the System

Figure 2-2 Unpacking the System Cabinet

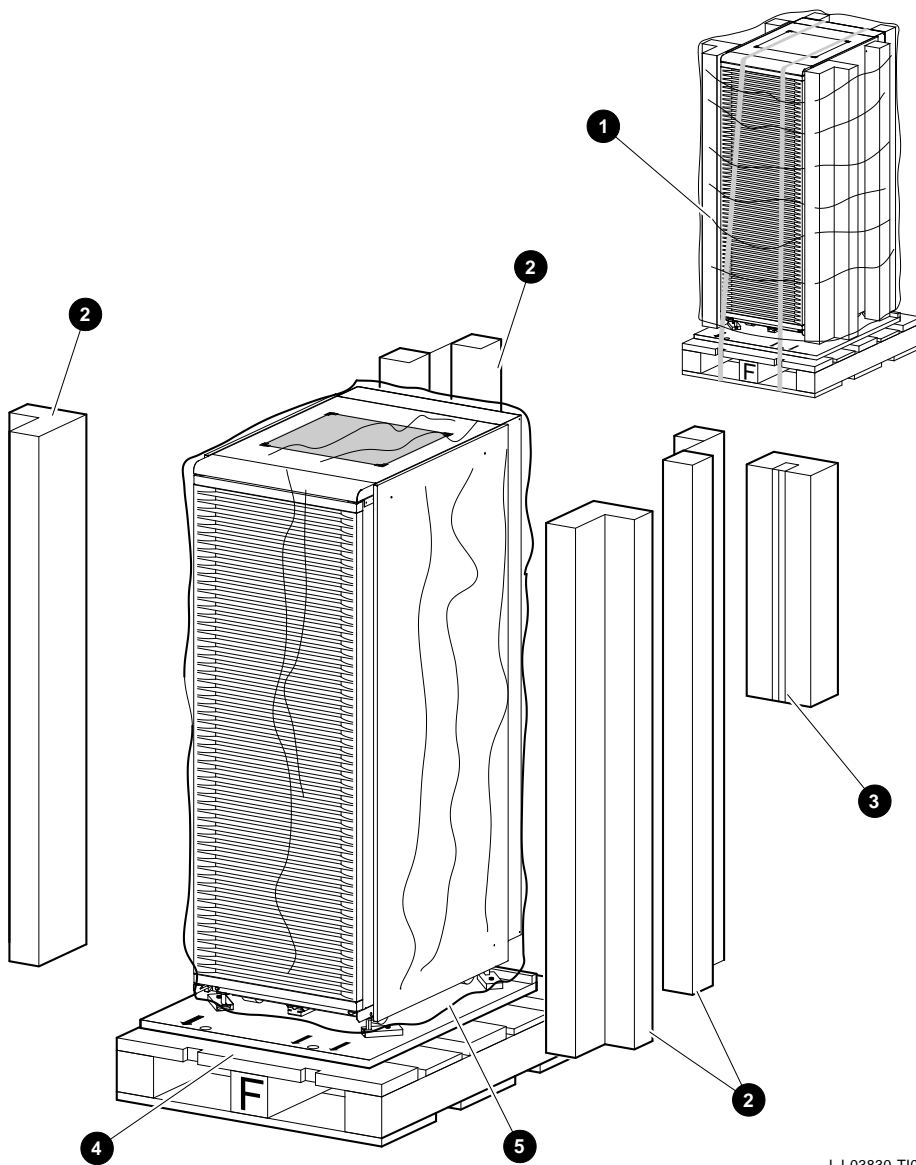

LJ-03830-T10

Unpacking the System

6. Refer to Figure 2–3. Remove the four shipping bolts ⑥ and brackets ⑦ that secure the four cabinet leveler feet ⑧ to the pallet ④.
7. Remove the ramps ⑨ from the shipping carton and set the ramps in the holes ⑩ provided at the front of the pallet ④. Ensure that the arrows ⑪ on the ramps match the pallet arrows ⑫ as shown in Figure 2–3.

Caution

In the next step, the leveler feet must be fully retracted to prevent contact with the ramp or the floor when the cabinet is unloaded from the pallet.

8. Adjust the four cabinet leveler feet ⑧ and the leveler foot on the stabilizer bar ⑬ to the maximum upward position.
Turn the lock nut down on each leveler foot (Figure 2–3) until it makes contact with the leveler hex nut, and then turn the leveler hex nut up until it raises the leveler foot to the maximum upward position. The cabinet should now rest on the casters so that the lever feet will not touch the ramps.

Unpacking the System

Figure 2-3 Installing the Ramps

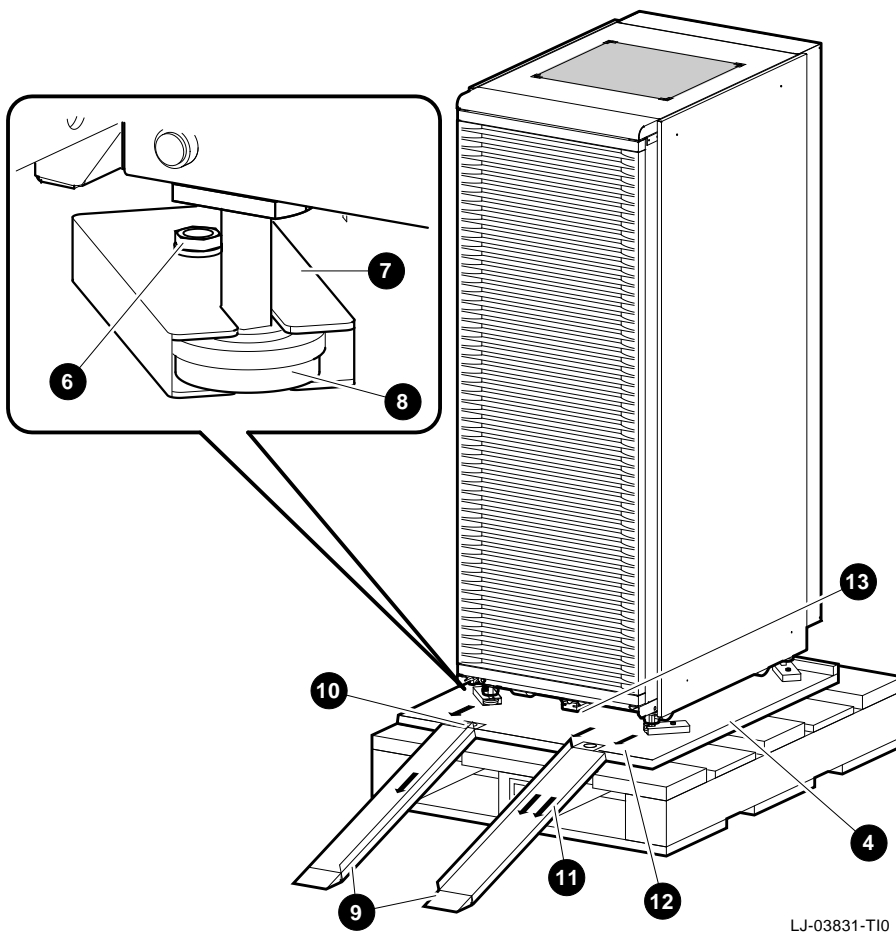

LJ-03831-T10

Unpacking the System

Warning

In the following step, use sufficient personnel to move the cabinet off the pallet. A fully configured cabinet can weigh up to 576 kg (1,280 lb). Equipment installed in the cabinet can make the cabinet top heavy or cause it to accelerate rapidly down the ramps if not restrained. Be prepared to guide and control the motion of the cabinet.)

9. To remove the cabinet from the skid, refer to Figure 2–4 and roll the cabinet down the ramps using sufficient personnel for safety.
10. Wheel the cabinet to the desired location.
11. Adjust the leveler feet downward so that the load is removed from the casters.

Caution

Ensure that the leveler feet extend enough to carry the load of the cabinet so that the casters spin freely. If not, damage to the casters will result over an extended period of time.

12. Using a spirit level, adjust the leveler feet to level the cabinet.

Unpacking the System

Figure 2-4 Removing the Cabinet from the Skid

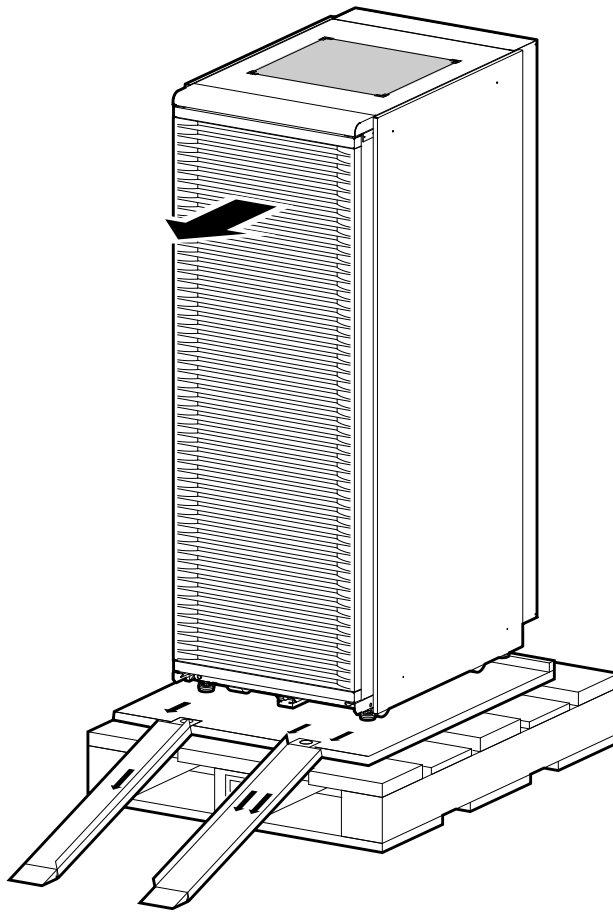

LJ-03832-T10

Unpacking the System

Checking the Shipment

Check the bill of lading to verify that all items have been received.

If the shipment is damaged or if any items are missing, notify the delivery agent, and contact the Digital sales representative.

Save all packing material in case the equipment needs to be moved to a new location, or returned for repairs.

During System Installation

During installation of the cabinet, one or more of the following procedures may be required:

- Removing and replacing the rear door
- Removing and replacing the front door latch bracket
- Removing and replacing the front filler panels
- Adjusting the stabilizer bar
- Using the interlock system
- Removing and replacing the front bezel

Removing and Replacing the Rear Door

To remove the rear door, refer to Figure 2–5 and proceed as follows:

Removal

1. Loosen the two M6 screws ❶ securing the tabs ❷ on the rear door ❸ to the cabinet ❹.
2. Grasp both sides of the rear door ❸ about midway up the door. Then lift the door off and away from the two brackets ❺ and the M6 screws ❶.
3. Place the rear door ❸ outside of the work area.

Replacement

To replace the rear door, reverse the removal procedure, steps 1 through 3.

During System Installation

Figure 2-5 Removing and Replacing the Rear Door

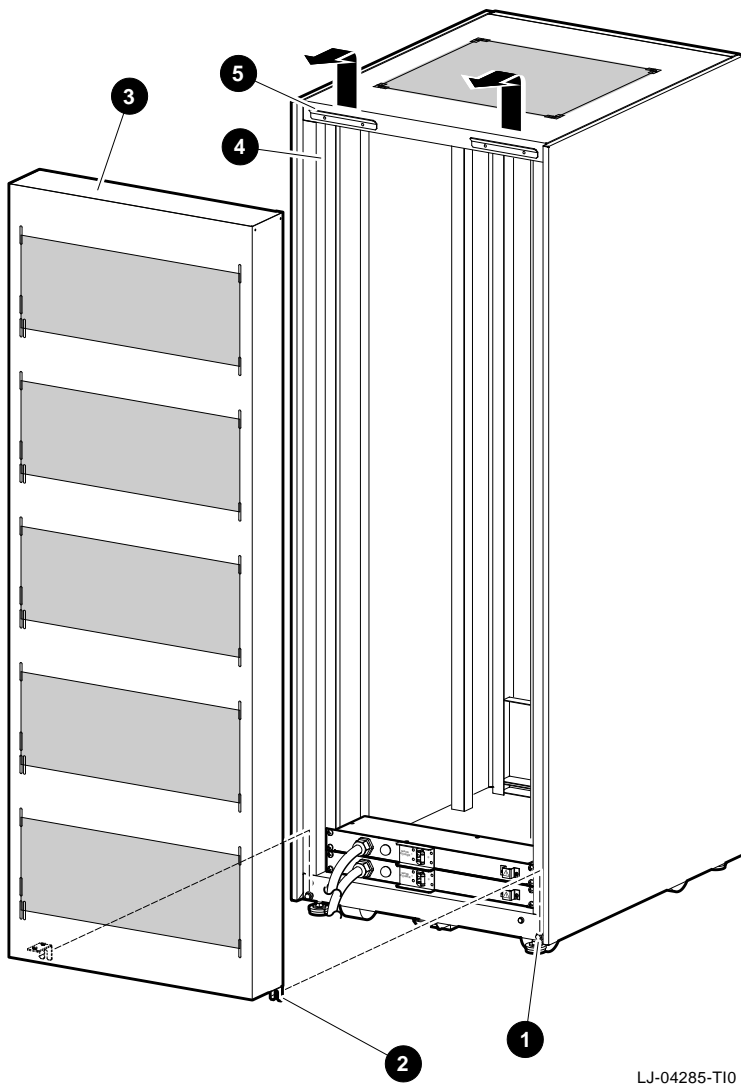

LJ-04285-T10

During System Installation

Removing and Replacing the Front Door Latch Bracket

The front door latch bracket prevents the left-side access door on an AlphaServer 2100 RM series system installed in the top of the H9A10 cabinet from being fully opened, and must be removed to allow access. To remove the front door latch bracket, refer to Figure 2-6 and proceed as follows:

Removal

Remove the two 8-32 screws ❶ and two 8-32 kepnuts ❷ that secure the front door latch bracket to the cabinet frame.

Replacement

To replace the front door latch bracket, align the two holes on the front door latch bracket with the two holes on the cabinet frame, and secure it in place with the two 8-32 screws ❶ and two 8-32 kepnuts ❷.

During System Installation

Figure 2-6 Removing and Replacing the Front Door Latch Bracket

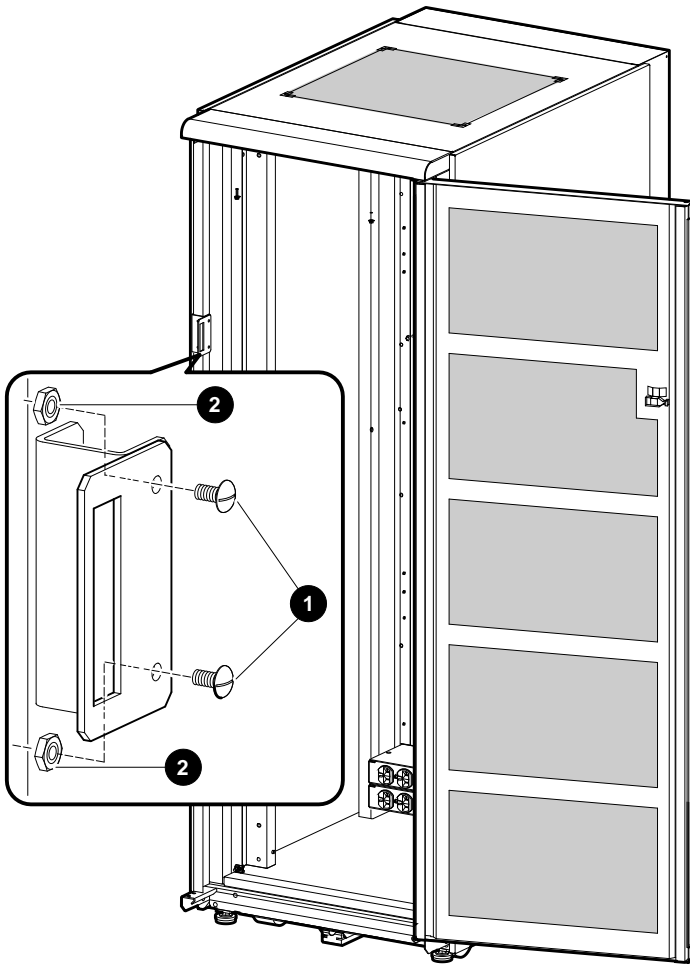

LJ-04290-T10

During System Installation

Removing and Replacing the Front Filler Panels

To remove a front filler panel, refer to Figure 2-7 and proceed as follows:

Removal

Grasp the front filler panel ❶ on both sides and then pull straight back away from the cabinet.

Replacement

To replace a front filler panel ❶, align the sockets ❷ on the front filler panel (refer to the exploded view) with the appropriate ball studs ❸ on the rails ❹ and push the panel into place.

During System Installation

Figure 2-7 Removing and Replacing the Front Filler Panels

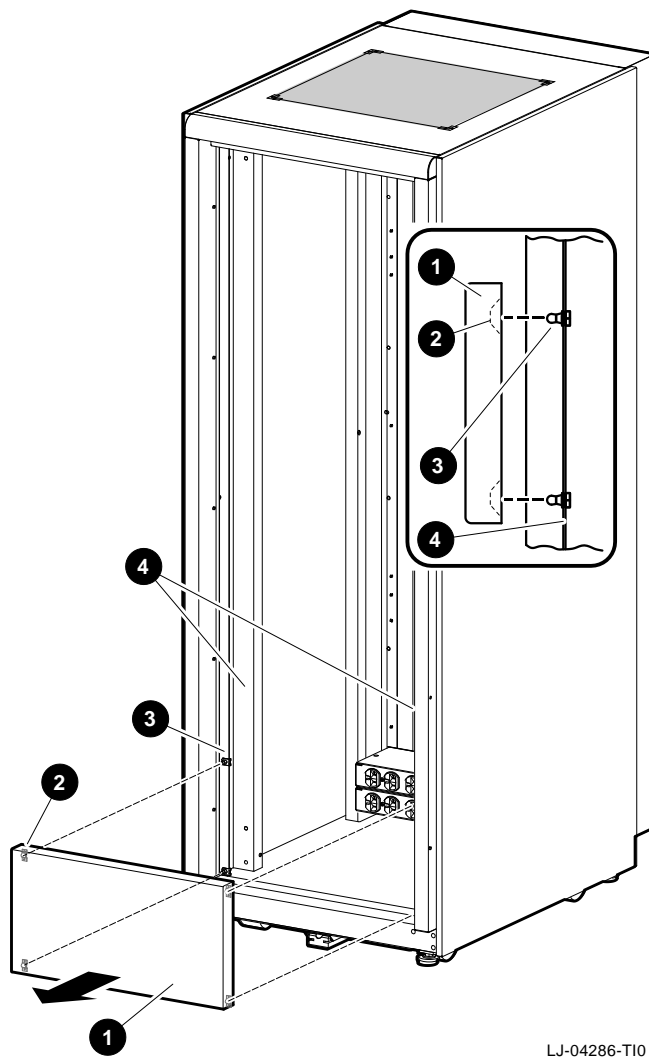

LJ-04286-T10

During System Installation

Adjusting the Stabilizer Bar

As shown in Figure 2–8 the stabilizer bar ❶ pulls straight out from the bottom front of the cabinet ❷. When the stabilizer bar is fully extended, adjust the foot ❸ at the end of the stabilizer bar until it touches the floor.

Warning

The stabilizer bar must be fully extended before any system is extended out of the cabinet on its slides.

The system cabinet can hold several system configurations. The amount of force required to tip or make the cabinet unstable differs with each configuration.

During System Installation

Figure 2-8 Pulling Out and Adjusting the Stabilizer Bar

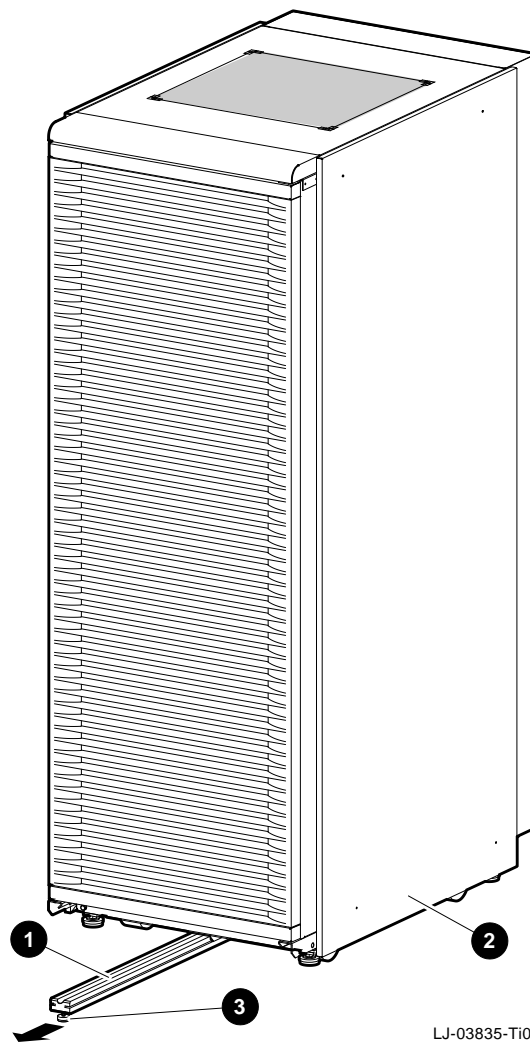

During System Installation

Using the Interlock System

The interlock system helps prevent cabinet instability by allowing only one system at any one time to be pulled out of the cabinet.

As shown in Figure 2–9 the interlock system consists of a vertical bar ❶ on which are mounted actuator latches ❷ for each product installed in the cabinet. These actuator latches engage the interlock actuator bracket ❸ on the rear of rackmount systems.

When a rackmount system is pulled out of the cabinet, the actuator latches ❷ rotate to prevent any other rackmounted system that has an interlock actuator bracket from being pulled out of the cabinet.

The expanded view (A) shows the position of the actuator latches when all systems are pushed into the cabinet. The expanded view (B) shows the position of all actuator latches after one system has been pulled out.

During System Installation

Figure 2-9 The Interlock System

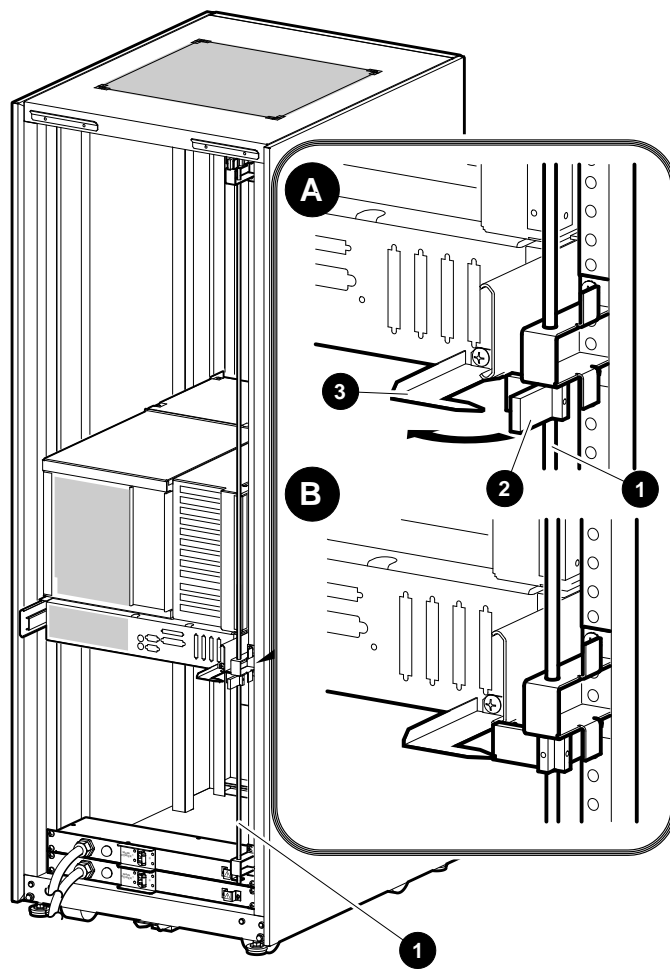

LJ-04293-T10

During System Installation

Removing and Replacing the Front Bezel

To connect or disconnect the power cord to the system AC connector, the front bezel must be removed.

Removal

Refer to Figure 2–10 to remove the front bezel ②. Press in at the bottom of the two pull loops ④ on the bezel to rotate them down and out from the bezel. Then, using the two pull loops, pull the bezel away from the system.

Replacement

Refer to Figure 2–10 to install the front bezel ②. Align the ball-stud receivers ① on the front bezel ② with the ball studs ③ on the front of the system. Press the front bezel ② into place.

Figure 2-10 Removing and Replacing the Front Bezel

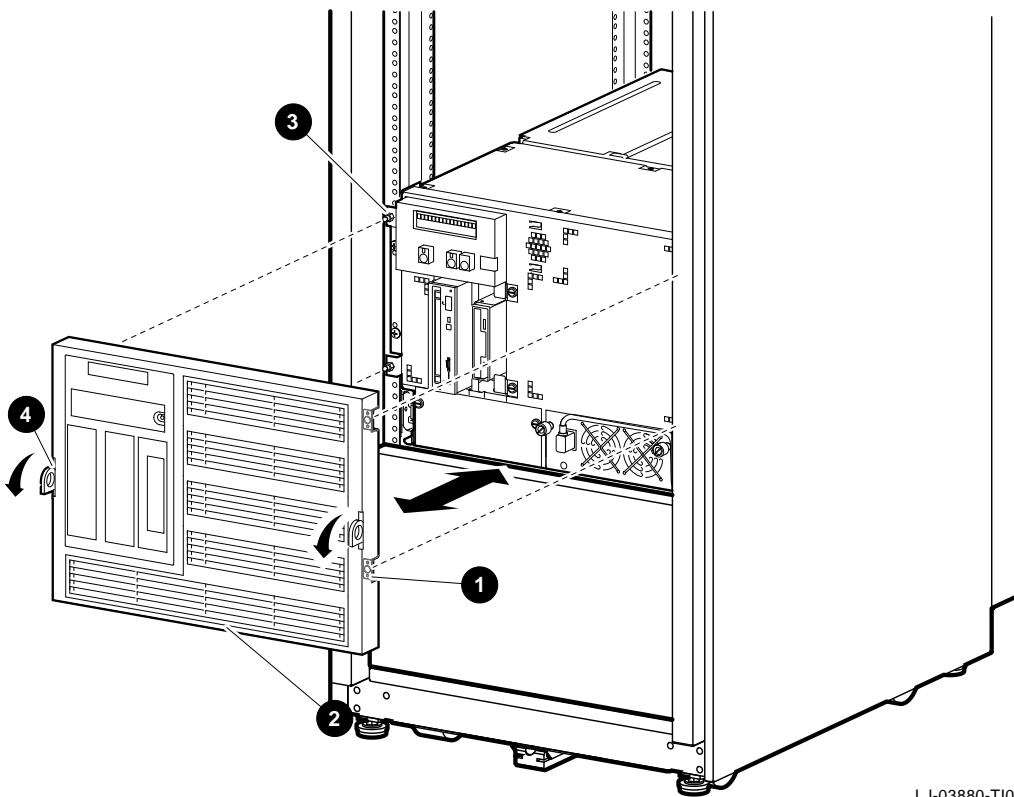

LJ-03880-T10

Connecting the Terminal

Connect either a video graphics array (VGA) monitor or a Digital VT-series terminal (VTxxx) to the system as shown in Figure 2-11. Use the H8571-J adapter that was shipped with your system to connect a VT-series terminal.

Refer to the documentation that is shipped with the terminal for information on how to connect the keyboard and set up the terminal. Ensure that the VT-series terminal is set to 9600 baud.

Connecting the Terminal

Figure 2-11 Connecting the Terminal

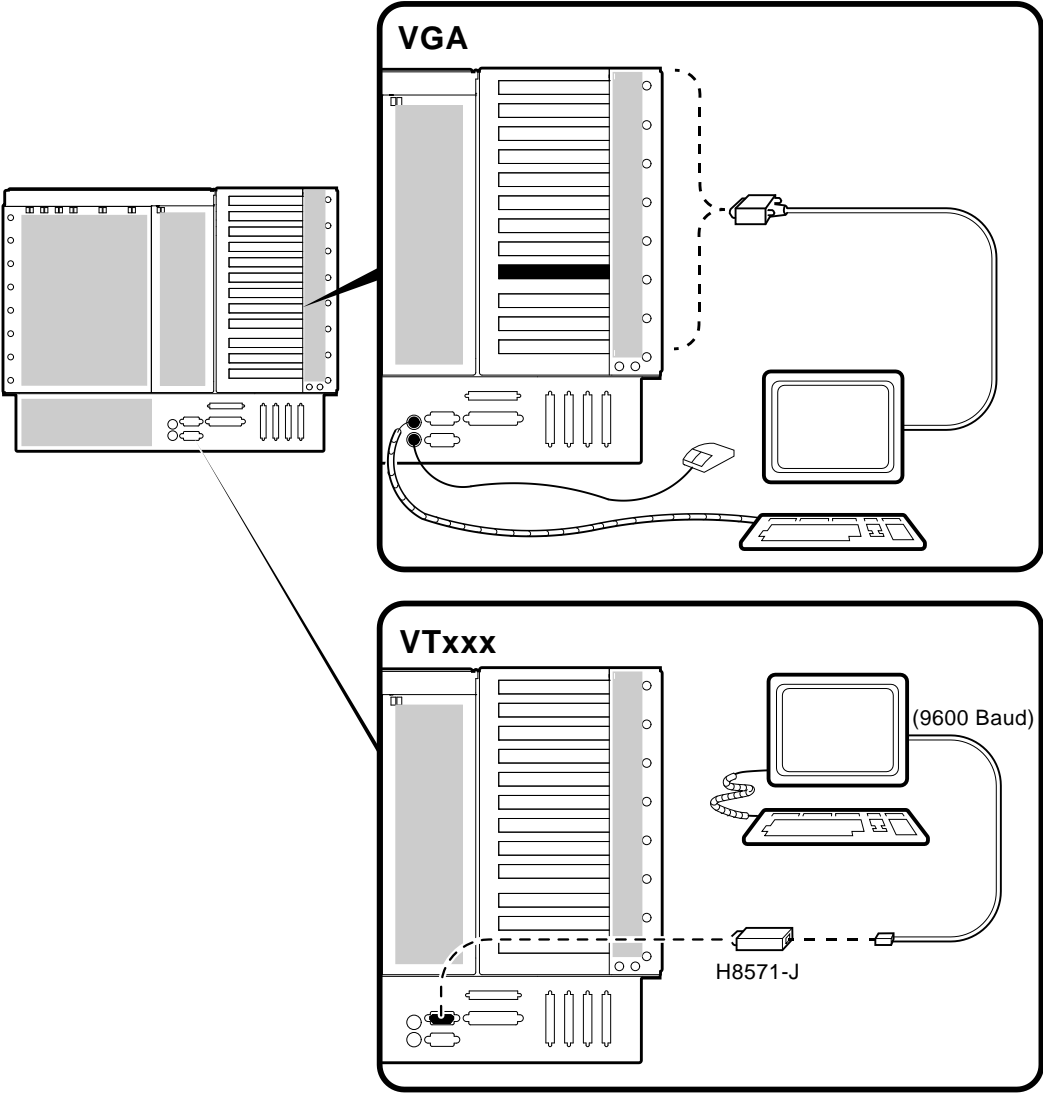

LJ-03783-T10A

Connecting to Networks

Overview

The standard network option for your system is Ethernet. However, your system can support other network options by using network adapters that can be connected to the EISA and PCI buses.

For information about connecting your system to networks other than Ethernet, refer to the documentation that came with the network adapter.

Ethernet

The system can be connected to a ThinWire, AUI, or 10BASE-T Ethernet network as shown in Figure 2-12.

Caution

Before connecting the system to an Ethernet network, turn off the DC power to the system as described in “Turning the System Off” in Chapter 3.

Figure 2-12 Ethernet Network Connections

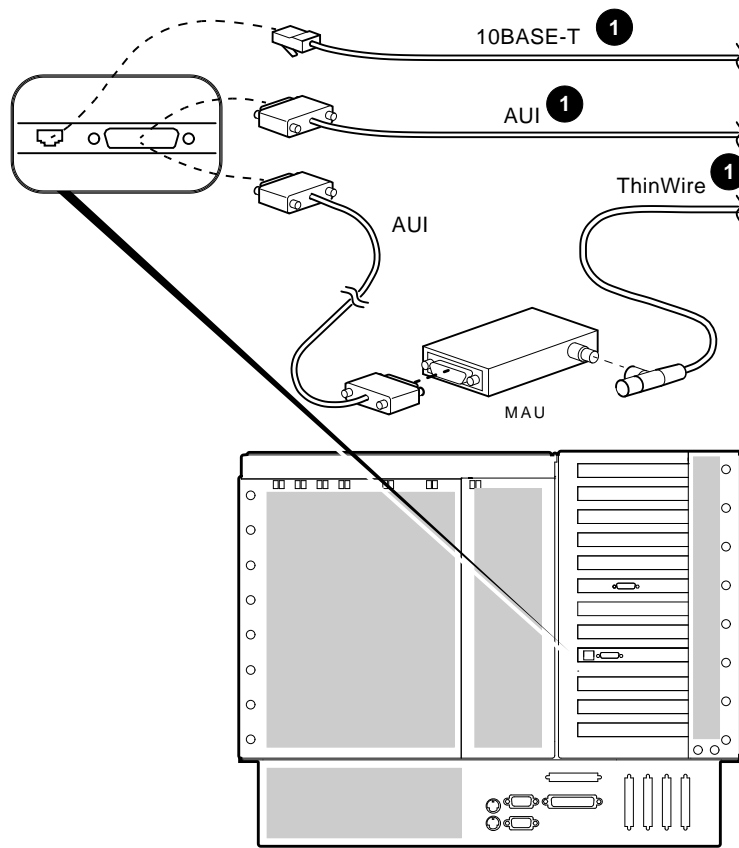

LJ-03779-T10A

❶ Indicates Ethernet options

Connecting Peripherals

Serial/Parallel Connections

Connect a serial or parallel printer, modem, or console terminal to your system through the serial and parallel ports at the rear of the system (refer to Figure 2–13).

Caution

Before connecting serial or parallel devices to the system, turn off the DC power to the system as described in “Turning the System Off” in Chapter 3.

For information about connecting a specific device to your system, refer to the documentation for that device.

Note

The cable that connects to the rear of the VGA terminal has multiple connectors. These connectors are either color-coded or coded by letters that indicate the color. Use the coding on the cable and the corresponding coding on the terminal to determine where to attach each cable connector.

Figure 2-13 Connecting Serial and Parallel Devices

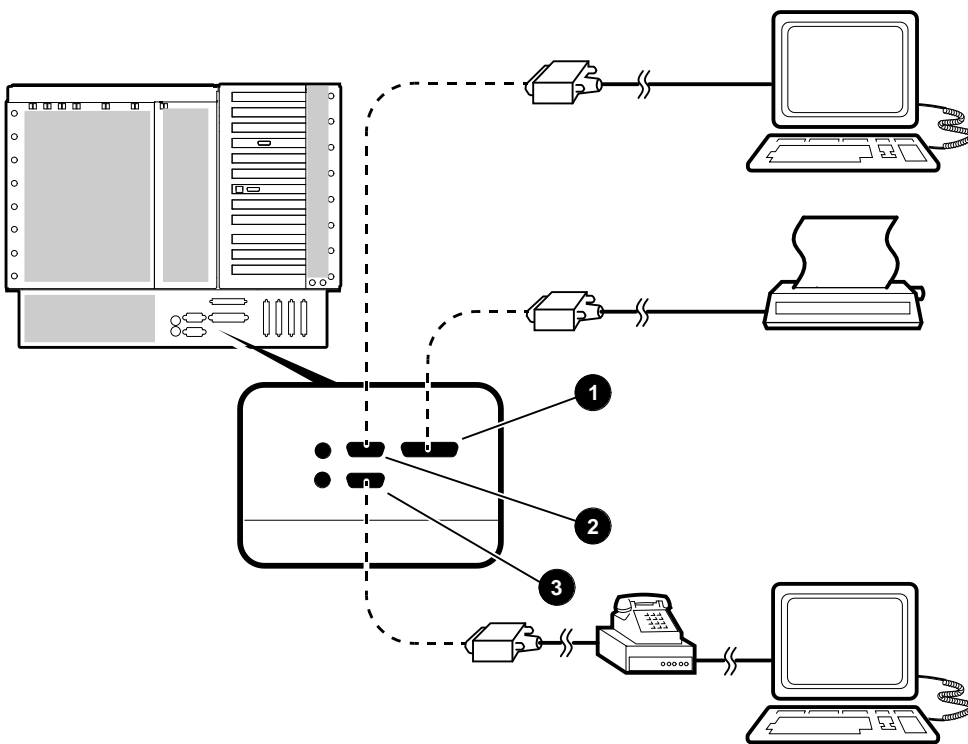

LJ-03782-T10

- ❶ Parallel port
- ❷ Serial port (COM1) (console terminal)
- ❸ Serial port (COM2) (auxiliary console device)

Connecting Peripherals

Expanding the System

As shown in Figure 2-14, the AlphaServer 2100 CAB system can be expanded from SCSI port E ❶ by removing the SCSI terminator (1) and connecting the appropriate cable (2) from the SCSI device connector.

Locations ❷ for optional ports (A through D) are available for the RAID options and the DSSI options.

Figure 2-14 SCSI Expansion and Optional RAID and/or DSSI Ports

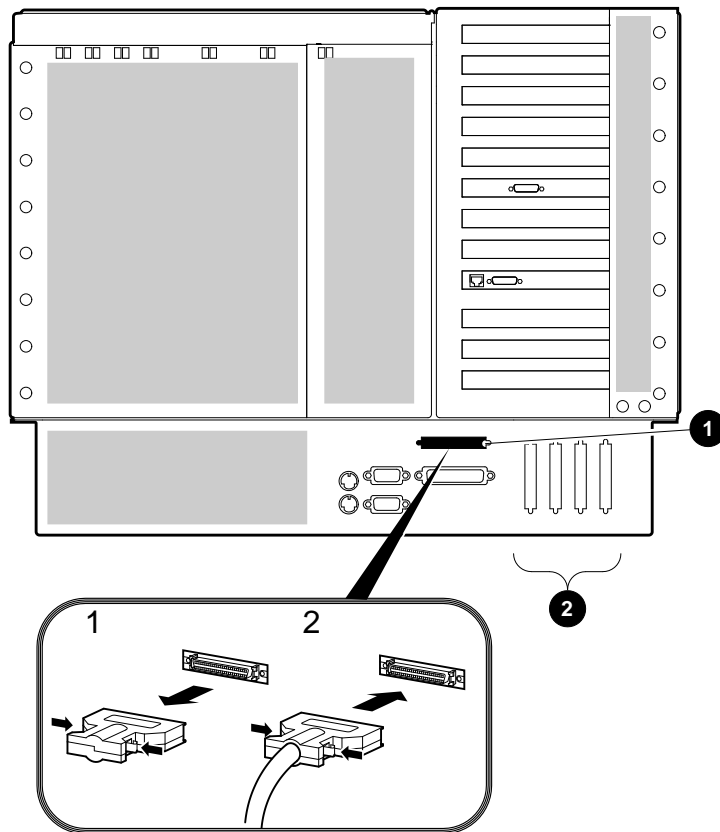

LJ-03765-T10

1 Port E, SCSI expansion port

2 Optional port locations (A through D) for RAID options and DSSI options

3

System Operation

In This Chapter

This chapter covers the following topics:

- Operator Control Panel
- Turning the System On
- Turning the System Off
- Invoking Console Mode
- Operating Storage Devices
- Operating a Compact Disc Drive
- Operating a DAT Tape Drive
- Operating a Floppy Drive
- Operating a QIC Tape Drive

Operator Control Panel

The operator control panel, shown in Figure 3–1, is located on the front of the system. It contains a diagnostic display and buttons that allow the user to power up, halt, and reset the system.

Figure 3–1 Operator Control Panel

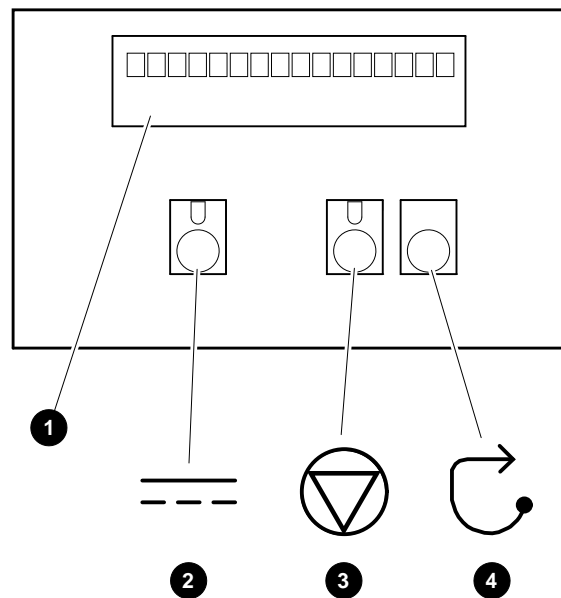

LJ-03778-T10

❶ Power-Up/Diagnostic Display

The power-up/diagnostic display shows system status messages during the power-up and diagnostics sequence. Use the display to check the results of system self-tests.

For information about interpreting specific messages, refer to the section “Interpreting the Operator Control Panel Power-Up/Diagnostic Display” in Chapter 5.

② **DC On/Off**

The DC On/Off button controls the flow of DC power to the system. Use the DC On/Off button and the AC power cord to turn system power on and off. The DC On/Off light, located on the DC On/Off button, is on whenever DC power is present.

③ **Halt (DEC OSF/1 and OpenVMS systems only)**

The Halt light, located on the Halt button, comes on briefly during the system self-tests. Thereafter, the Halt light comes on and remains on whenever DC power is present and the Halt button is set to the “in” position.

Before Power-Up: Pressing the Halt button before you power up the system boots the SRM console (even if your system is set to boot Windows NT) and prevents the system from booting the operating system.

Before booting the operating system, you must press the Halt button to the “out” position, and, if you are booting Windows NT, switch to the ARC console (enter the arc command).

Invoking Console Mode: Pressing the Halt button invokes console mode when DEC OSF/1 and OpenVMS are running. Pressing the Halt button has no effect when Windows NT is running.

Caution

Pressing the Halt button interrupts your operating system session. Before pressing the Halt button, shut down the operating system according to the operating system shutdown procedure described in your operating system documentation.

Returning to Operating System Mode: To return to operating system mode, press the Halt button to the “out” position and reboot the operating system.

Operator Control Panel

Note

If you press the Halt button by mistake and few or no console commands have been entered, it may be possible to resume your operating system session by entering the `continue` command.

④ Reset

Pressing the Reset button resets the system. The system aborts all current processes, initializes, and performs startup self-tests. Use the Reset button to reset the system if it hangs or to initialize the system if you have changed system settings.

Caution

Pressing the Reset button halts all system processes. *Do not* press the Reset button while the operating system is running unless your system is hung and you have exhausted all other ways of terminating the process.

Turning the System On

Overview

Turning on the system involves the following steps:

1. Checking the system settings
2. Applying power to the system
3. Checking the diagnostic indicators
4. Booting the operating system

Before You Begin

To perform some of the instructions in this procedure, you will need to open the operator control panel door. The key used to lock and unlock the door is shipped with the system in the system accessories carton. The keylock on the front of the system is shown in Figure 1-5.

Turning the System On

Checking the System Settings

Before turning the system on, ensure that the system buttons are in the positions shown in Figure 3-2.

Figure 3-2 Powered-Down System Settings

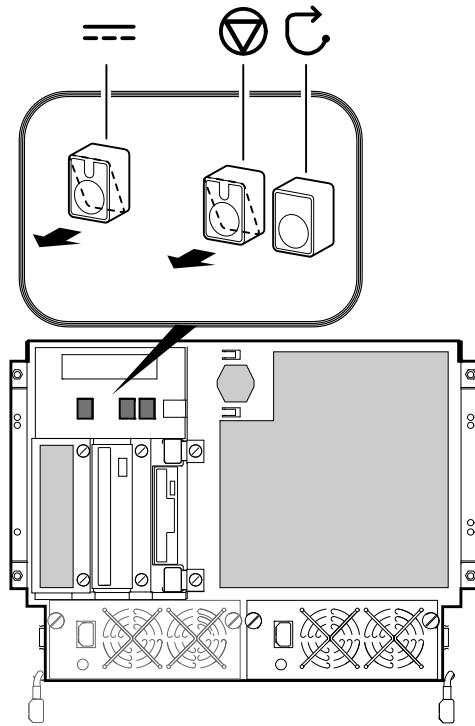

LJ-03773-T10

Applying Power to the System

Note

If there are any external expansion boxes (for example, expansion boxes that house storage devices) connected to the system, turn the power on to those devices first before applying power to the system.

Apply power to the system as shown in callouts 1 through 4 in Figure 3-3.

Figure 3-3 Applying Power to the System

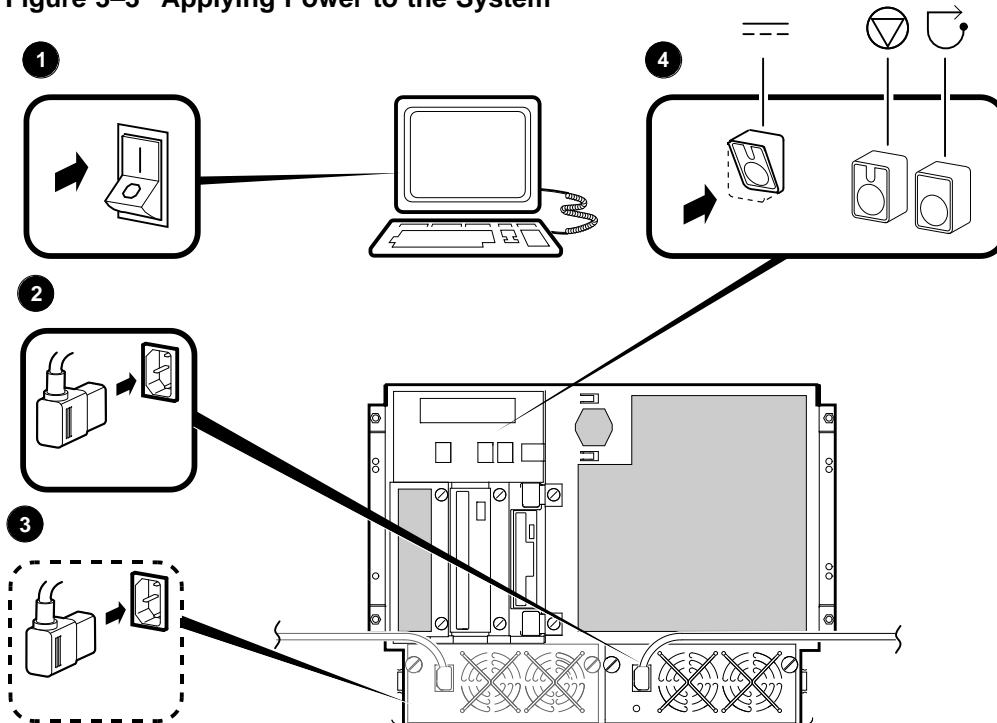

LJ-03775-T10

Turning the System On

Displaying Power-Up Information

Power-up information is typically displayed on the system's console terminal. The console terminal may be either a graphics terminal or a serial terminal (connected through the COM1 serial port). The setting of the console environment variable determines where the system will display power-up output. Set this environment variable according to the console terminal that you are using.

Synopsis:

```
set console output_device
```

Arguments:

graphics	Displays the power-up output to a graphics terminal or device connected to the VGA module at rear of the system.
serial	Displays the power-up output to a device connected to the COM1 port at the rear of the system.

Example:

```
>>> set console serial
>>>
```

Checking the Diagnostic Indicators

After the system is turned on, check the status of the three diagnostic indicators: the power-up/diagnostic display on the operator control panel, the system startup, and the console prompt (DEC OSF/1 or OpenVMS systems) or Boot menu (Windows NT systems).

If any of the diagnostic indicators do not appear as described, refer to Chapter 5 for help.

Power-Up/Diagnostic Display

The power-up/diagnostic display will display the following message for several seconds:

```
starting console
```

Once the system has completed self-tests, the power-up /diagnostic display will display the value of the `ocp_text` environment variable (default value is "Model X/XXX: the CPU variant and system model number"). For information about changing the value of the `ocp_text` environment variable, refer to the "set `ocp_text`" section in Chapter 1 of the *AlphaServer 2000/2100 Firmware Reference Guide*.

Turning the System On

System Startup Screen

The system startup screen will scroll. To stop the screen display from scrolling, enter **[Ctrl/S]**. To resume scrolling, enter **[Ctrl/Q]**.

The screen will look similar to the following example:

```
starting console on CPU 0
Testing Memory bank 0
Testing Memory bank 1
probing hose 0, PCI
slot 0 -- ewa -- DECchip 21040-AA
slot 1 -- pka -- NCR 53C810
slot 2 --      -- Intel 82375EB
probing hose 1, EISA
slot 2 -- pkb -- ADP0001
slot 3 -- era -- DEC4220
slot 4 -- dra -- MLX0070
probing hose 2, PCI
starting console on CPU 1
 2:35:54 March 4, 1994
Memory Testing and Configuration Status
Module  Size  Base Addr  Intlv Mode  Intlv Unit  Status
-----  ----  -
0       64MB  00000000   1-Way      0           Passed
1
2
3
Total Bad Pages 0
Testing the System
No Disks available for testing
Testing the Network
Alpha AXP (TM) Server Console T3.5-12, built on Mar  1 1994 at
18:20:28
```

Console Prompt or Main Menu

The appropriate response on your console terminal depends on the operating system that you plan to boot.

Note

If neither a console system prompt or a Main menu is displayed, press **[Return]** several times.

Turning the System On

DEC OSF/1 or OpenVMS Systems

DEC OSF/1 and OpenVMS systems are supported by the SRM firmware. Refer to Chapter 1 in the *AlphaServer 2000/2100 Firmware Reference Guide*.

If you are booting a DEC OSF/1 or OpenVMS system, the console prompt for the SRM firmware should be displayed. The prompt will vary depending on how many CPUs are in your system:

```
>>> (1 CPU)
P00>>> (multiple CPUs)
```

Note

If CPU0 failed during power-up tests, or has an error logged in its EEPROM, the system will “failover” to another CPU. The number of the CPU serving as the primary CPU is displayed in the SRM prompt; for example, P02>>> or P02>>>, and so on.

Windows NT Systems

Windows NT systems are supported by the ARC firmware. Refer to Chapter 2 in the *AlphaServer 2000/2100 Firmware Reference Guide*. Systems using Windows NT power up to the ARC boot menu show below:

```
ARC Multiboot Alpha AXP Version n.nn
Copyright (c) 1994 Microsoft Corporation
Copyright (c) 1994 Digital Equipment Corporation
```

Boot menu:

```
Boot Windows NT
Boot an alternate operating system
Run a program
Supplementary menu...
```

Use the arrow keys to select, then press Enter.

Turning the System On

Note

If the response on your terminal does not correspond to the operating system that you plan to boot, you are using the wrong console interface for your operating system. Switch to the other console as described in the following information.

Switching from SRM to ARC

To switch from the SRM console interface to the ARC console interface, enter the `arc` command as follows:

```
>>> arc
```

Once the console firmware is loaded and the system is initialized, the first screen of the ARC console interface is displayed.

Switching from ARC to SRM

To switch from the ARC console interface to the SRM console interface, perform the following steps:

1. From the Boot menu, select the Supplementary menu.
2. From the Supplementary menu, select Set up the system.
3. From the Setup menu, select Switch to OpenVMS or OSF console. The operating system console can be selected.
4. Select the operating system and press on Setup menu.
5. When the message Power-cycle the system to implement the change displays, press the Reset button. (Do not press the DC On/Off button.)

Once the console firmware is loaded and the system is initialized, the SRM console interface prompt is displayed.

Turning the System On

Multiprocessor Failover

AlphaServer 2100 systems support multiprocessor failover, which allows the system to power up and boot the operating system even if only one CPU is working.

During power-up or system reset, the serial ROM tests check for a good CPU, starting with CPU0, to serve as the primary CPU. The primary CPU is the only CPU that tests memory and reads the flash ROM code.

If a CPU fails serial ROM tests, or if the CPU has an error logged to its serial control bus EEPROM, that CPU is disabled. The lowest numbered passing CPU serves as the primary CPU. If all CPU modules fail their power-up diagnostics, then CPU0 will serve as the primary CPU.

If any of the CPUs fail during power-up, the halt button LED on the operator control panel lights for a few seconds, and the CPU status message on the power-up/diagnostic display indicates which CPU failed (Table 3-1).

The following firmware commands can also be used to examine the status of CPU tests or to see if errors are logged to a CPU.

- show fru
- show error
- show config

Note

The CPU number of the CPU serving as the primary CPU is displayed in the SRM prompt; for example, P01>>> or P02>>>, and so on.

Table 3–1 Interpreting Operator Control Panel Power-Up Display

Message	Meaning
TEST	Is displayed while system performs diagnostic exercisers. The type of module under test, its slot number, and the currently executing test number are also displayed.
FAIL	<p>If an error is detected, a failure message is displayed and the Halt button LED lights for a few seconds. The error is logged to the appropriate module via the serial control bus. In nearly all cases, the power-up tests continue. The module type and slot number for the field replaceable unit (FRU) that failed, along with the test number that detected the error are also displayed.</p> <p>Module types and/or slot numbers:</p> <ul style="list-style-type: none"> CPU_nn — CPU module (0 or 1) MEM_nn — Memory module (0 or 1) I/O_0 — I/O backplane I/O_1 — Expansion I/O module (PCI) PCInn — PCI modules (0–2) EISAnn — EISA modules (1–7) MBD — System backplane
CPU STATUS	<p>Summary of CPU testing—The status of right to left, starting with CPU0 is displayed:</p> <ul style="list-style-type: none"> “P” — CPU passed “F” — CPU failed “–” — CPU not present
STARTING CPU #	The console is starting the primary CPU.
TEST MEM BANK #	The console is testing memory.
PROBE I/O SUBSYS	The console is checking the PCI.
SYSTEM RESET	The Reset button has been pressed.
Alpha AXP nnnMHz	When the system is under operating system control, the CPU speed is displayed unless you supply your own text using the <code>ocp_text</code> environment variable.

Turning the System On

Preboot Tasks

You may need to perform some of the following tasks before booting your operating system:

- Run the EISA Configuration Utility.
- Check the required environment variable settings.
- Change the way your system powers up or boots.
- Verify your configuration.

The remainder of this section contains more information about each of these tasks.

Run the EISA Configuration Utility

If an EISA or ISA module has been added, removed, or moved, the EISA Configuration Utility must be run before booting the operating system. Refer to the “EISA Bus Options ” section in Chapter 4.

Check the Required Environment Variable Settings—DEC OSF/1 or OpenVMS

If you are running DEC OSF/1 or OpenVMS, check that the settings for the following environment variables match your configuration. The console command to reset the variable is shown in parentheses. Refer to Chapter 1 in the *AlphaServer 2000/2100 Firmware Reference Guide*.

- Operating system (set os_type)
- Ethernet device type (set ew*0_mode)
- Speed for Fast SCSI devices (set pk*0_fast)
- Boot device (set bootdef_dev)
- Boot flags (set boot_osflags)

Reminder

Except for the `set bootdef_dev` and the `set boot_osflags` commands, the environment variables are set by initializing the system before booting the operating system. The system can be initialized either by entering the `init` command at the `>>>` prompt or by pressing the Reset button on the operator control panel.

Change Default Power-Up or Bootstrap

To change the way the system powers up or boots the operating system, change the default values for your system's environment variables. Typical changes would be to set the system to autoboot or to change the default boot device.

- For DEC OSF/1 or OpenVMS systems, review Chapter 1 in the *AlphaServer 2000/2100 Firmware Reference Guide*, particularly Table 1, Task Summary Table.
- Windows NT systems boot automatically. To prevent autoboot follow the steps specified in Table 3–2

Table 3–2 Setting No Autoboot

Step	Action	Result
1	Access the Setup menu.	The system displays the Setup menu.
2	Choose the Setup autoboot menu item and press Enter.	The system displays a prompt asking you whether you want the system to boot automatically.
3	To prevent autoboot, choose No and press Enter.	The system displays the Setup menu.
4	Choose the Supplementary menu, and save changes . . . menu item and press Enter.	The system saves the changes that you have made in the NVRAM and then displays the Supplementary menu.

Turning the System On

Verify Your Configuration

- DEC OSF/1 or OpenVMS systems

The following SRM console commands are used to verify system configuration on systems running either the DEC OSF/1 or OpenVMS operating system:

- show config—Displays the buses on the system and the devices found on those buses.
- show device—Displays the devices and controllers in the system.
- show memory—Displays main memory configuration.
- set and show—Set and display environment variable settings.

For more information about these console commands, refer to Chapter 4.

- Windows NT systems

The following ARC menu options are used to verify system configuration on systems running the Windows NT operating system:

- Available Boot Devices Display—Lists the ARC boot device names for devices installed in the system.
- Set Default Variables—Allows you to select values for Windows NT firmware environment variables.

For more information about these menu options, refer to Chapter 2 in the *AlphaServer 2000/2100 Firmware Reference Guide*.

Switching Between Operating Systems

Because configuration files are different for each operating system, you must perform the following tasks to switch from one operating system to another on your system:

1. Invoke console mode if you are not already in console mode.
For information about invoking console mode, refer to the “Invoking Console Mode” section presented later in this chapter.
2. Insert the ECU diskette containing the configuration files for the operating system that you are going to switch to.
3. Run the EISA Configuration Utility (ECU) from that diskette.
For information about running the ECU, refer to the “Configuring EISA Options ” section in Chapter 4.
4. Remove the ECU diskette.
At this point you are using the ARC console. You can proceed to boot Windows NT at any time.
5. If you are booting DEC OSF/1 or OpenVMS, you must switch from the ARC to the SRM console before booting the operating system. See the “Switching from ARC to SRM” section presented earlier in this chapter.

Turning the System On

Booting the Operating System

One of several operating systems can be booted:

- DEC OSF/1
- OpenVMS
- Windows NT

In the following instructions, it is assumed that the operating system has already been booted at least once.

Condition	Reference
If Factory Installed Software (FIS) has not been booted	See the Factory Installed Software document that came with your system.
If the system was not shipped with Factory Installed Software, and the operating system software has not been loaded or booted	See the installation documentation that came with your operating system.

Booting DEC OSF/1 or OpenVMS Software

When booting either DEC OSF/1 or OpenVMS systems, the console prompt >>> should be displayed. Boot the operating system as follows:

Step	Action
1	Enter boot or b at the console prompt. >>> b The system boots the operating system using the default values for the boot device and boot flags. A booting system software screen is displayed on the console terminal. After several minutes, the operating system login banner is displayed on the console terminal.
2	Log in at the login prompt. Once the operating system prompt is displayed, the system is ready for normal operation.

For additional information about the `boot` command, refer to the `boot` section in Chapter 1 in the *AlphaServer 2000/2100 Firmware Reference Guide*.

Booting Windows NT Software

When booting a Windows NT system, the Windows NT menu should be displayed. Windows NT will automatically begin booting after the Main menu is displayed for several seconds.

Autobooting the Operating System

If the system is set to autoboot, the operating system will automatically boot after you power up the system, press the Reset button, or after recovery from a system crash.

To autoboot DEC OSF/1 or OpenVMS systems:

- Set the `auto_action` environment variable to either `boot` or `restart`. For more information, refer to the `set auto_action` command in Chapter 1 in the *AlphaServer 2000/2100 Firmware Reference Guide*.
- Ensure that the default boot device has been set to the device from which you want the operating system to boot. (Enter `show bootdef_dev` to see whether your default boot device has already been assigned.) For information about setting the default boot device, refer to the `set bootdef_dev` command in Chapter 1 in the *AlphaServer 2000/2100 Firmware Reference Guide*.

Note

The Windows NT operating system autoboots by default. If your system does not autoboot, set the system to autoboot by following the instructions in the *AlphaServer 2000/2100 Firmware Reference Guide*.

Turning the System Off

Before You Begin

It may not be necessary to turn the system off to recover from system problems. First try pressing the Reset button on the operator control panel.

Turning Off the DC Power

If the system needs to be turned off, proceed as follows:

1. Shut down the operating system according to the operating system shutdown procedure described in your operating system documentation.
2. Press the DC On/Off button and the Halt button to the positions shown in Figure 3-4. (If the Halt button is set to the "in" position, the system will not boot the next time the system is turned on.)

Turning the System Off

Figure 3-4 Turning Off the System

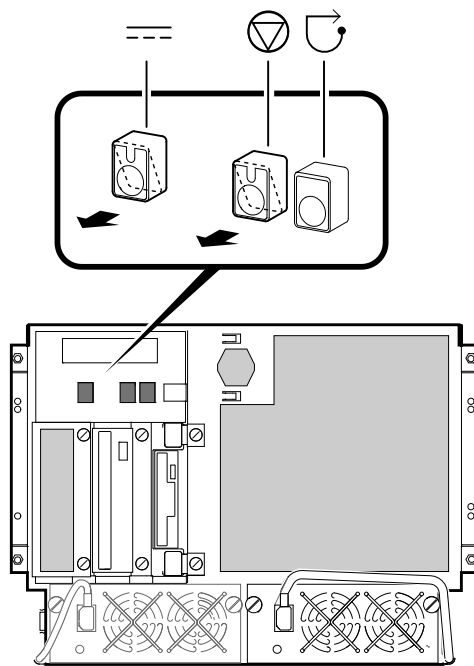

LJ-03777-T10

Turning the System Off

Extended Power-Down (AC Power)

If an extended power-down is required, proceed as follows:

1. Turn off the DC power to the system as described in the previous section.
2. Turn off the AC power to the system by unplugging the AC power cord(s) as shown in Figure 3-5.

Warning

If two power supplies are present, unplug the AC power cords from each power supply.

Figure 3-5 Turning Off the AC Power

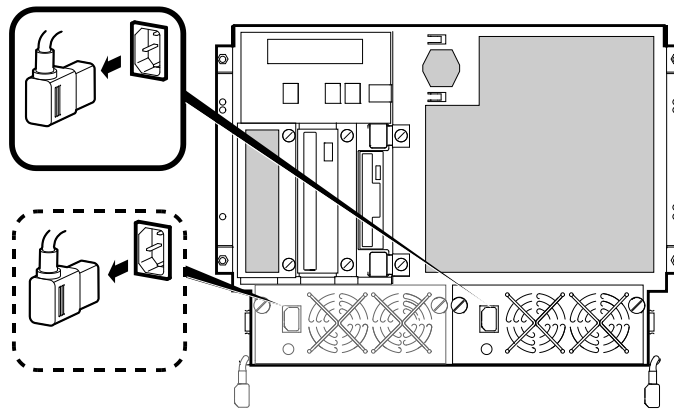

LJ-03780-T10

Invoking Console Mode

Console Subsystem

The console subsystem contains firmware code (software code embedded in the hardware) that offers service functions such as initializing and testing the hardware and bootstrapping the system software. Because the AlphaServer 2100 CAB system supports multiple operating systems, the server has two different versions of console firmware. They are explained in detail in Chapter 1 (for users running DEC OSF/1 or OpenVMS) and Chapter 2 (for users running Windows NT) in the *AlphaServer 2000/2100 Firmware Reference Guide*.

Console Terminal

A console terminal is *required* for your system. It allows the issuing of commands to the system while the operating system is not running.

Console Mode

Console mode is the state in which the system and the console terminal operate under the control of the console firmware. When commands can be issued from the console terminal and firmware is executing, the system is in the console mode.

On DEC OSF/1 and OpenVMS systems, the console mode prompt for a system with one CPU is >>>. The console mode prompt for a system with multiple CPUs is P00>>>. The control characters and supported keys can be used to enter console commands at the console mode prompt.

Invoking Console Mode

Invoke console mode by shutting down the operating system according to the operating system shutdown procedure described in your operating system documentation.

Invoking Console Mode

Using the Halt Button

If you are running DEC OSF/1 or OpenVMS, you can invoke the console mode by pressing the Halt button on the operator control panel. However, ensure that the operating system is shut down first.

Caution

Press the Halt button only after the operating system has been shut down using the proper software shutdown procedure.

Pressing the Halt button has no effect if you are running Windows NT.

For more information about using the Halt button, refer to the  description in the “Operator Control Panel” section in this chapter.

Remote Access

When you are running DEC OSF/1 or OpenVMS systems, you can invoke the console mode from a remote terminal that is connected to the system through the COM2 port at the rear of the system (refer to Figure 2–13).

To invoke console mode perform the following steps:

1. Connect the remote terminal to the system.
2. Shut down the operating system.
3. When the shutdown completes, press .

The console prompt (>>> or P00>>>) is displayed.

Note

If the response on your terminal does not correspond to the operating system that you plan to boot, you are using the wrong console interface for your operating system. Switch to the other console as described in the “Switching from SRM to ARC” section or the “Switching from ARC to SRM” section in this chapter.

Operating Storage Devices

Overview

Mass storage devices are drives that are used to store large amounts of data for extended periods.

For Additional Information

This section describes how to insert and remove media into removable-media drives. For more information about a specific drive, refer to the documentation for that drive.

Before You Operate Mass Storage Devices

Before operating mass storage devices:

- Set up the device.
Typically, you must set up a device before you can begin using it. You set up a device while the operating system is running. Refer to your operating system documentation for information about how to set up a device.
- Familiarize yourself with the care and maintenance required by the device.
Refer to the option documentation for care instructions for each option.

Operating Storage Devices

The remaining sections of this chapter describe how to operate removable-media mass storage devices.

Operating a CD-ROM Drive

CD-ROM Drive Description

CD-ROM drives read information from removable, read-only compact discs.

Your system may have one of two types of CD-ROM drives: a caddyless drive or one that must be used with a disc caddy.

Caution

Handle a disc by its edges. Do not touch the surface of a disc. Fingerprints and dust can cause the disc to malfunction.

Caddyless Drive

Figure 3–6 shows the components of a caddyless drive.

- ❶ Compact disc
- ❷ Headphone port
- ❸ Headphone volume control
- ❹ Busy light
- ❺ Eject button
- ❻ Manual eject hole

Operating a CD-ROM Drive

Figure 3-6 Caddyless CD-ROM Drive

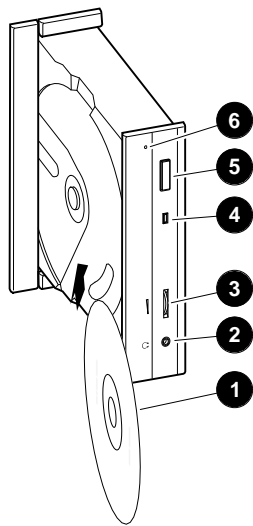

MA070393A

Operating a CD-ROM Drive

Drive with Caddy

Figure 3-7 shows the components of a CD-ROM drive with a disc caddy.

- ❶ Headphone port
- ❷ Headphone volume control
- ❸ Disc caddy slot
- ❹ ID dimple
- ❺ Busy light
- ❻ Eject button
- ❼ Manual eject hole
- ❽ Compact disc caddy
- ❾ Compact disc

Operating a CD-ROM Drive

Figure 3-7 CD-ROM Drive with Caddy

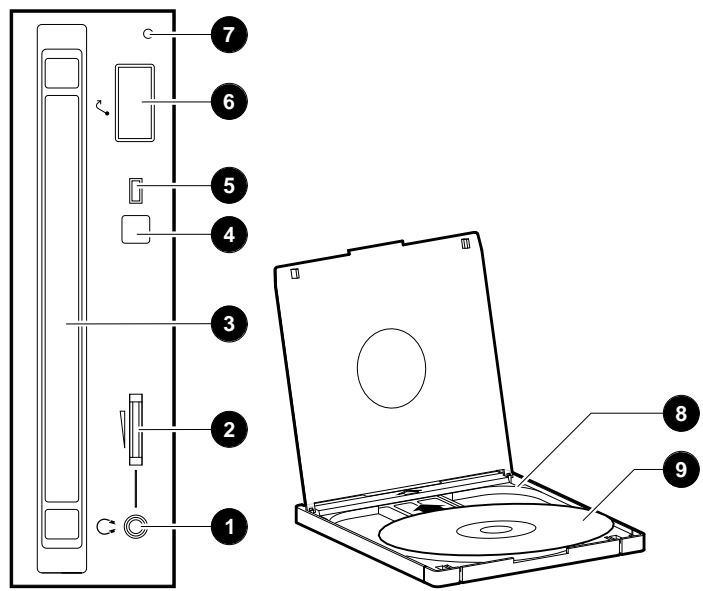

MA068593A

Operating a CD-ROM Drive

Inserting and Removing a Compact Disc

Caddyless Drives

Insertion: (Figure 3-8):

1. Press the drive Eject button (❶) shown in Figure 3-8.
The disc drawer ejects part way as shown in Figure 3-8.
2. Gently pull the disc drawer far enough out so that you can insert the compact disc.
3. Insert the disc into the drawer.
4. Push the drawer back in.

The busy light comes on. When the busy light goes off, the drive is ready to use. To operate the drive, follow the instructions provided with your system software.

Removal: (Figure 3–8):

1. Press the drive Eject button (❶) shown in Figure 3–8.
The disc drawer ejects part way as shown in Figure 3–8.
2. Gently pull the drawer out far enough so that you can remove the compact disc.
3. Remove the compact disc.
4. Push the drawer back into the drive.

Figure 3–8 Inserting and Removing a Caddyless Compact Disc

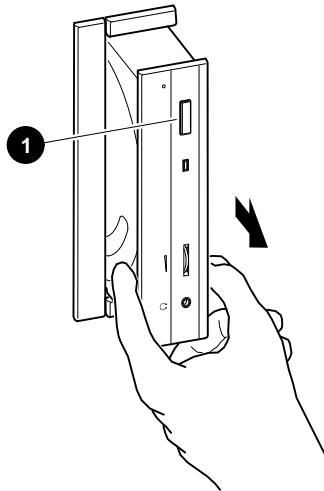

MA070293A

Drives with Caddy

Insertion: (Figure 3–9):

1. Gather both the caddy and the disc you wish to insert.
2. If there is a protective film on the center of the caddy lid, remove the film ❶.
3. Open the caddy by pressing the tabs on both sides of the caddy at the end opposite the shutter ❷.
4. Set the disc, printed side up, into the caddy ❸.
5. Press firmly on both corners to close the caddy lid.
6. Insert the caddy into the drive ❹. Push the caddy gently into the drive as far as it will go. The caddy should be completely inside the drive when properly inserted.
The busy light comes on when the caddy has been inserted correctly.
7. When the busy light goes off, the drive is ready to use. To operate the drive, follow the instructions provided with your system software.

Removal: (Figure 3–9):

1. Press the eject button ❺.
The caddy will automatically eject part way.
2. Remove the caddy from the drive.

Operating a CD-ROM Drive

Figure 3-9 Inserting and Removing a CD-ROM Caddy

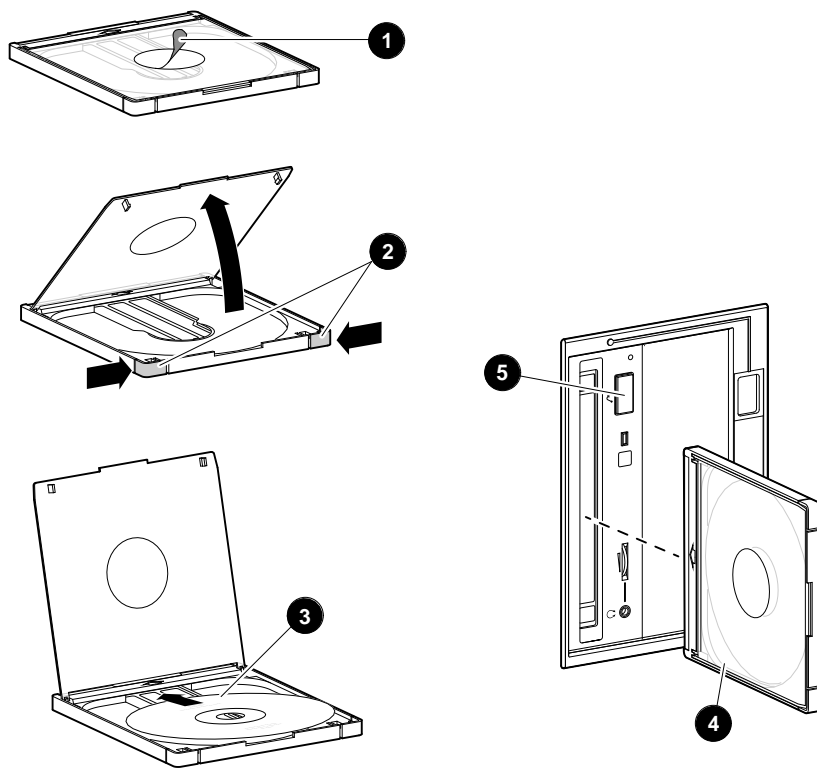

MA068693A

Operating a DAT Tape Drive

DAT Description

A DAT tape drive stores information on removable tape cartridges. Figure 3–10 shows the components of a DAT drive.

- ❶ Tape/activity light
- ❷ Write-protect light
- ❸ Tape cassette slot
- ❹ Tape unload button
- ❺ Tape cassette
- ❻ Write-protect switch (write-protected position)
- ❼ Write-protect switch (write-enabled position)

Inserting a Tape

To insert the tape into a DAT drive (Figure 3–10):

1. Check to see that the tape/activity light ❶ on the drive is off. If it is on, there is already a tape in the drive. Remove the tape from the drive before continuing. (See “Removing a Tape”.)
2. Set the write-protect switch on the tape that you wish to insert to either the write-protected ❻ or write-enabled ❼ position.
3. Insert the tape into the drive, with the tape oriented as shown in ❺.

Removing a Tape

To remove a tape from a DAT drive (Figure 3–10):

1. Check to see that the tape/activity light ❶ is on steady green (not flashing). If the tape/activity light is flashing, the drive has not finished completing a data transfer. Wait until the tape/activity light comes on steady green before proceeding.
2. Press the unload button ❹ to eject the tape.
The tape ejects part way.

Operating a DAT Tape Drive

3. Remove the tape from the drive.

Figure 3-10 Inserting and Removing a Tape: DAT

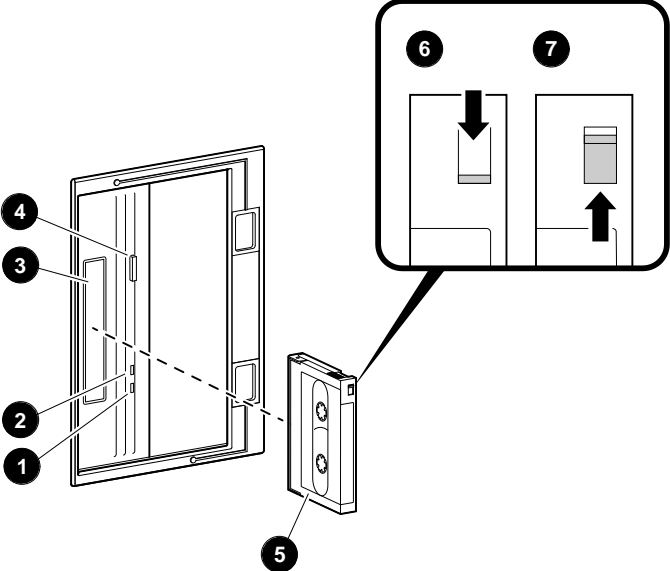

MA068393A

Operating a Diskette Drive

Diskette Drive Description

Diskette drives read information from, or write it to, removable diskettes. Figure 3–11 shows a diskette and the components of a diskette drive.

- ❶ Eject button
- ❷ Busy light
- ❸ Write-protect switch
- ❹ Write-protect switch (write-protected position)
- ❺ Write-protect switch (write-enabled position)

One diskette drive is located to the left of the removable-media mass storage compartment.

Inserting a Diskette

Insert a diskette into a diskette disk drive (Figure 3–11):

1. Set the write-protect switch on the diskette ❸ to either the write-protected ❹ or write-enabled ❺ position.
2. Insert the diskette into the drive as shown.

Removing a Diskette

Remove a diskette by pressing the Eject button on the diskette drive (❶ in Figure 3–11):

Figure 3-11 Diskette Drive and Diskette

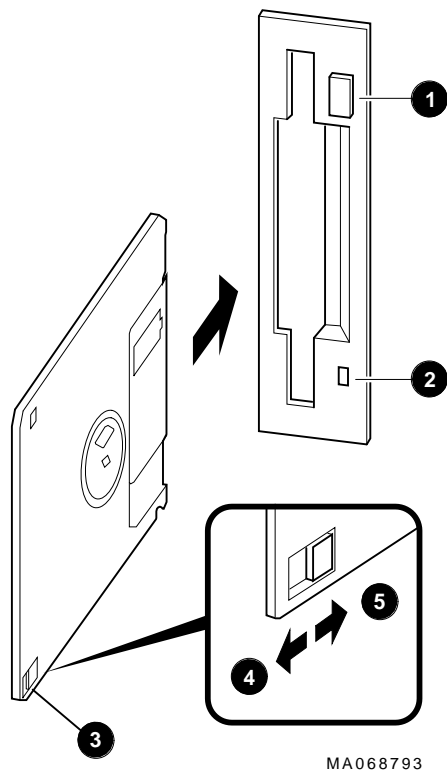

Operating a QIC Drive

QIC Drive Description

QIC tape drives read information from, or write it to, removable tapes. Figure 3–12 shows a QIC tape drive and a compatible tape.

Inserting a QIC Tape

Insert a QIC tape into a QIC tape drive as follows:

1. Set the write-protect switch on the tape to either the write-protected ❶ or write-enabled ❷ position.
2. Insert the tape into the drive ❸.

Removing a QIC Tape

Remove a QIC tape by pressing the Eject button on the QIC tape drive ❹:

Figure 3–12 QIC Tape Drive and QIC Tape

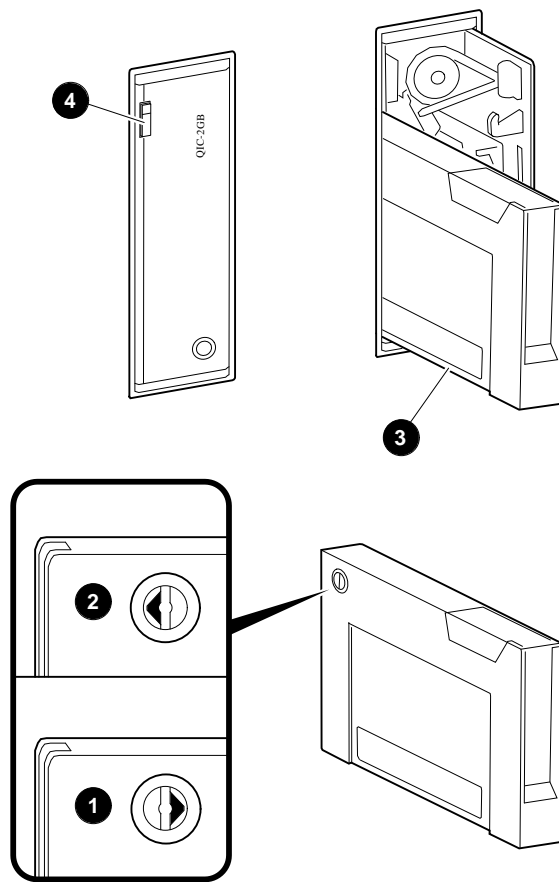

MA069393A

4

Options and Upgrades

In This Chapter

This chapter covers the following topics:

- Upgrade Overview
- Supported Options
- Verifying System Configuration
- System Bus Options
- Configuring System Options
 - System Bus
 - EISA Bus
 - ISA Bus
 - PCI Bus
 - SCSI Buses
- Power Supply Configurations
- Console Port Configurations

Upgrade Overview

Planning Your Upgrade

Plan an upgrade by performing the following tasks:

1. **Obtain an accurate list of the modules and devices in your current configuration.**

Refer to your operating system documentation for information concerning configuration information by using an operating system command.

You can also obtain configuration information in console mode. (Refer to “Invoking Console Mode” in Chapter 3.) Once you are in console mode, find configuration information as follows:

- If you are running DEC OSF/1 or OpenVMS, obtain a list of your system’s modules and devices by entering the show configuration command at the console prompt. (Refer to the “Verifying System Configuration ” section of this chapter for more information.)
- If you are running Windows NT, obtain a list of your system’s modules and devices by accessing the Hardware configuration display menu item.

2. **Decide how you wish to change your system.**

You can obtain a current description of supported options from the *Digital Systems and Options Catalog*.

3. **Determine whether you can install the new option yourself, or whether you need to contact a Digital service representative or other qualified service person.**

Note

The following options should only be installed by a qualified service person:

- Removable-media devices
 - Internal StorageWorks shelves
-

4. **Determine whether the upgrade will require you to add a second power supply to your system.**

If you have only one power supply, determine whether you need to add a second power supply. Refer to the “Power Supply Configurations ” section in this chapter.

5. **Order the options and, if necessary, a second power supply.**

6. **Install and configure the options.**

- To install the option, refer to the documentation shipped with the option.
- To configure the option, refer to the appropriate section in this chapter.

Supported Options

Supported Options

The AlphaServer 2100 CAB system provides support for a number of bus options. You can obtain a current list of supported options from several sources. The list is updated periodically as new options are added. Consult the following sections for the most convenient way for you to obtain the options list.

Access from the Internet

If you are an Internet participant, you can obtain the latest version of the supported options list as follows:

Access the list from the Digital FTP archive:

```
ftp.gatekeeper.dec.com: /pub/Digital/info/misc/2100-options.txt
```

Access the list from the Digital World-Wide Web server:

```
http://www.digital.com/info/misc/2100-options.abs.html
```

Access from CompuServe

CompuServe subscribers can access the list of supported options from the DEC4WNT forum, Library 4, Hardware Support. The file name is OPTS21.TXT.

Digital Systems and Options Catalog

You can obtain information about hardware configurations for the AlphaServer 2100 CAB system from the *Digital Systems and Options Catalog*. The catalog is regularly published to assist customers in ordering and configuring systems and hardware options. Each catalog printing presents all products that are announced, actively marketed, and available for ordering. If necessary, past editions should be retained for reference.

- Call 1-800-DIGITAL to talk to a consultant about your configuration.
- Access printable PostScript files of any section of the catalog from the Digital FTP archive on the Internet:

```
ftp gatekeeper.dec.com  
cd /pub/digital/info/soc
```

Verifying System Configuration

Before You Begin

Several console commands or menu options allow you to examine system configuration and environment variable settings. To use these commands or menu options, you will need to invoke console mode. For information about invoking console mode, refer to the “Invoking Console Mode” section in Chapter 3.

Firmware Menu Options for Windows NT

The following ARC menu options are used to verify the system configuration on systems running the Windows NT operating system.

- Display hardware configuration—Lists the ARC boot device names for devices installed in the system.
- Set Default Variables—Allows you to select values for Windows NT firmware environment variables.

For information about using these menu options, refer to Chapter 2 in the *AlphaServer 2000/2100 Firmware Reference Guide*.

To enter SRM commands, you must switch from the ARC to the SRM console. For information about switching to the SRM console, refer to the “Switching from ARC to SRM” section in Chapter 3. Switch back to the ARC console before booting the Windows NT operating system.

Firmware Console Commands for DEC OSF/1 and OpenVMS

The following SRM console commands are used to verify system configuration on systems running either the DEC OSF/1 or OpenVMS operating system.

- show config—Displays the buses on the system and the devices found on those buses.
- show device—Displays the devices and controllers in the system.
- show memory—Displays main memory configuration.
- set and show—Set and display environment variable settings.

Verifying System Configuration

For information about using the `set` and `show` commands to set and display environment variables, refer to Chapter 1 in the *AlphaServer 2000/2100 Firmware Reference Guide*.

System Bus Options

The system bus interconnects the CPU modules, memory modules, and the optional PCI expansion I/O module. It is the hardware structure through which data processed by the microprocessor is transferred throughout the system.

Figure 4-1 shows the location of the system bus and system bus options in the card cage. Your system supports options for several types of bus architectures; including EISA, ISA, and PCI. The next sections describe the system bus options for your system.

Figure 4-1 System Bus Option Locations

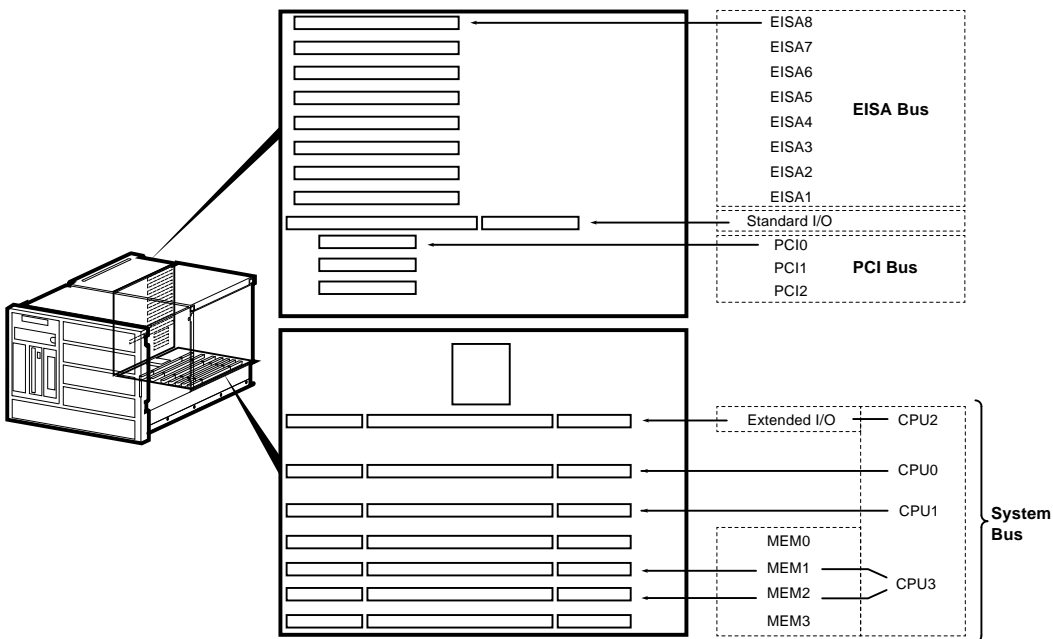

LJ-03787-T10

System Bus Options

CPU Modules

The system can support up to four CPU modules in a symmetric multiprocessing (SMP) configuration. Note the following:

- All systems must have a CPU module installed in system bus slot 2 (CPU 0).
- Systems with more than two CPUs displace the 64-bit PCI expansion or memory module capacity as shown in Figure 4-2.

Warning

Before installing a CPU module, turn off all power to the system (both AC and DC). Refer to the “Turning the System Off” section in Chapter 3.

Figure 4-2 System Bus Configurations According to the Number of CPUs

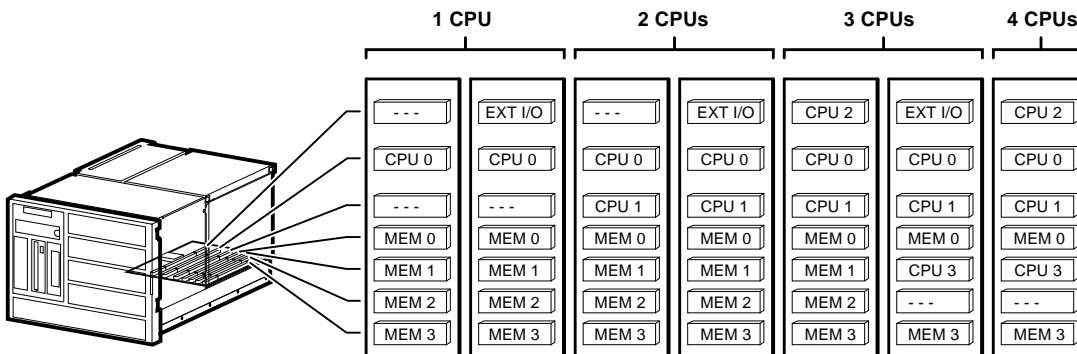

LJ-03788-T10



Warning: CPU and memory modules have parts that operate at high temperatures. Wait two minutes after power is removed before handling these modules.

Memory Modules

The system can support up to four memory modules (for a maximum memory capacity of 2 GB). A minimum of one memory module is required.

Warning

Before installing a memory module, turn off all power to the system (both AC and DC). Refer to the “Turning the System Off” section in Chapter 3.

Memory is available in three variations as follows:

- 80-ns memory modules
 - MS450–BA (B2021–BA) 64-MB 80-ns memory
 - MS450–CA (B2021–CA) 128-MB 80-ns memory
 - MS451–CA (B2022–CA) 512-MB 80-ns memory)

Expansion I/O (64-Bit PCI) Module

A CPU slot (system bus slot 1, CPU 2) can be substituted for additional I/O expansion. An expansion I/O module provides two 64-bit PCI slots.

Guidelines for Systems with SWXCR-Ex Controller

If you purchased a StorageWorks RAID Array 210 Subsystem for your AlphaServer 2100 CAB system, observe the guidelines below when you add, move, or reconfigure RAID devices. The RAID subsystem includes the SWXCR-Ex EISA backplane RAID controller.

- Run the EISA Configuration Utility (ECU) as described in this chapter to configure all modules on the EISA bus.
- Run the RAID Configuration Utility (RCU) as described in *StorageWorks RAID Array 200 Subsystem Family Installation and Configuration Guide* to set up the disk drives and logical units. The RCU is provided on a diskette with the RAID subsystem kit.
- On OpenVMS systems, RAID drives do not autoconfigure. See the *StorageWorks RAID Array 200 Subsystem Family Software User's Guide for OpenVMS AXP* for instructions on configuring your RAID devices on OpenVMS.

RAID Subsystem Documentation

For information about the RAID subsystem and specific operating systems, consult the documents listed in Table 4–1. These documents are included in your RAID subsystem kit. Refer to Table 5–11, Removable-Media Mass-Storage Problems in Chapter 5 for RAID troubleshooting hints related to the AlphaServer 2100 CAB system.

Table 4–1 RAID Subsystem Documentation

Document	Part Number
<i>StorageWorks RAID Array 200 Subsystem Family Installation and Configuration Guide</i>	EK-SWRA2-IG
<i>StorageWorks RAID Array 200 Subsystem Family Software User's Guide for OpenVMS AXP</i>	AA-Q6WVA-TE
<i>StorageWorks RAID Array 200 Subsystem Family Software User's Guide for OSF/1</i>	AA-Q6TGA-TE
<i>StorageWorks RAID Array 200 Subsystem Family Software User's Guide for Microsoft Windows NT</i>	AA-Q6SWA-TE

Standard I/O Module

Warning

Before installing the standard I/O module, turn off all power to the system (both AC and DC). Refer to the “Turning the System Off” section in Chapter 3.

The standard I/O module provides the standard set of I/O functions and is required in all systems. The standard I/O module resides in a dedicated slot (I/O) in the EISA bus card cage (refer to Figure 4–1). It provides:

- A Fast SCSI-2 controller chip that supports up to seven drives
- The firmware console subsystem in 512 KB of Flash ROM
- An Ethernet controller with AUI or twisted-pair connectors
- A floppy drive controller
- Two serial ports with full-modem control and the parallel port
- The keyboard and mouse interface
- The speaker interface
- The EISA-to-PCI bridge set
- The TOY clock

EISA Bus Options

The EISA bus (Extended Industry Standard Architecture bus) is a 32-bit I/O bus. The EISA bus is a superset of the 16-bit ISA bus and has been designed to accept newer 32-bit components while remaining compatible with older 8-bit and 16-bit cards.

EISA offers good performance, up to 33 MB/s for bus masters and direct memory access (DMA) devices. Up to eight EISA or ISA modules can reside in the EISA bus portion of the card cage. All slots are bus master slots. EISA slots can be filled in any order.

Figure 4–1 shows the location of the EISA options in the card cage. Access to the EISA options in the card cage is by way of the left-side access door shown in Figure 1–7. Ensure that the left-side access door is closed and its two retaining screws are tightened before turning the system on.

For information about installing a specific EISA option, refer to the documentation for that option. For information about configuring an EISA option, refer to the “Configuring EISA and ISA Options” section in this chapter.

Warning

Before installing EISA bus options, turn off all power to the system (both AC and DC). Refer to the “Turning the System Off” section in Chapter 3.



Warning: For protection against fire, use only modules with current-limited outputs.

ISA Bus Options

The ISA bus (Industry Standard Architecture bus) is a 16-bit I/O bus. The EISA bus is a superset of the ISA bus and has been designed to be backward compatible with 16-bit and 8-bit architectures. Therefore, ISA modules can be used in your server, provided the operating system supports the device.

Up to eight EISA or ISA modules can reside in the EISA bus portion of the card cage. Figure 4–1 shows the location of the options in the card-cage. Access to the options in the card cage is by way of the left-side access door shown in Figure 1–7. Ensure that the left-side access door is closed and its two retaining screws are tightened before turning the system on.

For information about installing a specific ISA option, refer to the documentation for that option. For information about configuring an ISA option, refer to the “Configuring EISA and ISA Options” section in this chapter.

Warning

Before installing ISA bus options, turn off all power to the system (both AC and DC). Refer to the “Turning the System Off” section in Chapter 3.



Warning: For protection against fire, use only modules with current-limited outputs.

Identifying EISA and ISA Options

An option board can be identified as an EISA or ISA by examining its contacts (refer to Figure 4-3):

- EISA boards have two rows of gold contacts with several gaps.
- ISA boards have one row of gold contacts and no more than one gap.

Figure 4-3 EISA and ISA Boards

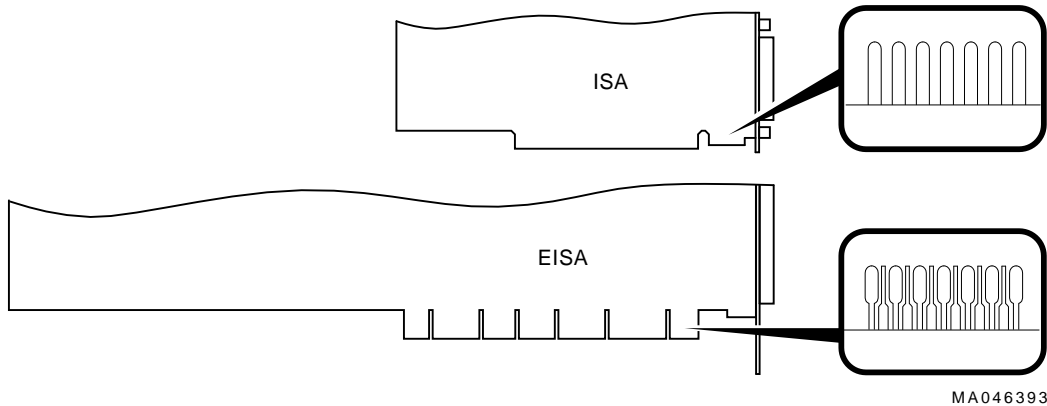

Configuring EISA and ISA Options

EISA Configuration Utility

Whenever you add, remove, or move an EISA or ISA board in your system, run the EISA Configuration Utility (ECU). Each EISA or ISA board has a corresponding configuration (CFG) file, which describes the characteristics and the system resources required for that option. The ECU uses the CFG file to create a conflict-free configuration. The ECU is a menu-based utility that provides online help. It serves as a guide through the configuration process. The ECU is run from the ARC menu interface.

System Configuration Diskette

The ECU is supplied on the System Configuration Diskette that was shipped with your system. Make a copy of the System Configuration Diskette and keep the original in a safe place. Use the backup copy for configuring the system. The System Configuration Diskette must have the volume label SYSTEMCFG.

Note

The CFG files supplied with the option to be installed may not work on this system if the option is *not supported*. Before installing an option, ensure that your system supports the option. The *Digital Systems and Options Catalog* lists the supported options.

Configuring EISA and ISA Options

Before Running the ECU

Before running the ECU, perform the following steps:

1. Install EISA option(s). (Install ISA modules *after* running the ECU.)

For information about installing a specific option, refer to the documentation for that option.

2. Familiarize yourself with the utility.

You can find additional information about the ECU, by reading the ECU online help. To read the online help, start the ECU (refer to the “Starting the ECU” section in this chapter). Online help for the ECU is located under step 1, Important EISA Configuration Information.

3. Familiarize yourself with the configuration procedure for your system:

- If you are configuring an EISA bus that contains only EISA options, refer to Table 4–2.
- If you are configuring an EISA bus that contains both ISA and EISA options, refer to Table 4–3.

4. Locate the ECU diskette for your operating system. Make a copy of the ECU diskette and keep the original in a safe place. Use the backup copy for configuring options.

- ECU Diskette DECpc AXP (AK-PYCJC-CA) for Windows NT systems
- ECU Diskette DECpc AXP (AK-Q2CRB-CA) for DEC OSF/1 and OpenVMS systems

The ECU diskette is shipped in the accessories carton with your system.

Note

The current version of ECU requires a VGA terminal.

Starting the ECU

Complete the following steps to start the ECU:

1. Invoke the console firmware.
 - **For systems running Windows NT**—Shut down the operating system or power up to the console Boot menu.
 - **For systems running DEC OSF/1 or OpenVMS**—Shut down the operating system and press the Halt button, or power up with the Halt button set to the in position. When the console prompt >>> displays, set the Halt button to the out position.
2. Start ECU as follows:
 - **For systems running Windows NT**—Select the following menus:
 - a. From the Boot menu, select the Supplementary menu.
 - b. From the Supplementary menu, select the Setup menu. Insert the ECU diskette for Windows NT systems (AK-PYCJC-CA) into the floppy drive.
 - c. From the Setup menu, select Run EISA configuration utility from floppy. This boots the ECU program.
 - **For systems running DEC OSF/1 or OpenVMS**—Start the ECU program as follows:
 - a. Insert the ECU diskette for DEC OSF/1 or OpenVMS systems (AK-Q2CRB-CA) into the floppy drive.
 - b. Enter the ecu command.

The message loading ARC firmware displays.
Loading the ARC firmware takes approximately two minutes. When the firmware has finished loading, the ECU program is booted.
3. Complete the ECU procedure according to the guidelines provided in the following sections.
 - When configuring an EISA bus that contains only EISA options, refer to Table 4–2 in the “Configuring EISA Options ” section in this chapter.

Configuring EISA and ISA Options

Note

When configuring only EISA options, do not perform step 2 of the ECU, Add or Remove Boards. (EISA modules are recognized and configured automatically.)

- When configuring an EISA bus that contains both ISA and EISA options, refer to Table 4-3 in the “Configuring EISA/ISA Options ” section in this chapter.
4. After you have saved the configuration information and exited from ECU:
 - **For systems running Windows NT**—Remove the ECU diskette from the floppy drive and boot the operating system.
 - **For systems running DEC OSF/1 or OpenVMS**—Remove the ECU diskette from the floppy drive. Return to the SRM console firmware as follows:
 - a. From the Boot menu, select the Supplementary menu.
 - b. From the Supplementary menu, select Set up the system.
 - c. From the Setup menu, select Switch to OpenVMS or OSF console. This allows the operating system console to be selected.
 - d. Select your operating system and then press **Enter** on Setup menu.
 - e. When the message Power-cycle the system to implement the change displays, press the Reset button. (Do not press the DC On/Off button.)Once the console firmware is loaded and the device drivers are initialized, boot the operating system.
 5. Verify that the new options are configured correctly.

Configuring EISA Options

EISA boards are configured automatically. Refer to Table 4–2 for a summary of steps to configure an EISA bus *that contains no* ISA options. Review the “Before Running the ECU” section presented earlier in this chapter. Then run the ECU as described in the “Starting the ECU” section also presented earlier in this chapter.

Note

It is not necessary to run step 2 of the ECU, Add or Remove Boards. (EISA modules are recognized and configured automatically.)

Configuring EISA Options

Table 4–2 Summary of Procedure for Configuring EISA Bus (EISA Options Only)

Step	Explanation
Install the EISA option.	Use the instructions provided with the EISA option.
Power up the system and run the ECU.	If the ECU locates the required CFG files, it displays the Main menu. The CFG file for the option may reside on a configuration diskette packaged with the option or may be included on the System Configuration Diskette.
Note	
It is not necessary to run step 2 of the ECU, Add or Remove Boards. (EISA modules are recognized and configured automatically.)	
View or edit details (optional).	The View or Edit Details ECU option is used to change user-selectable settings or to change the resources allocated for these functions (IRQs, DMA channels, I/O ports, and so on). This step is not required when using the board's default settings.
Save your configuration.	The Save and Exit ECU option saves your configuration information to the system's nonvolatile memory.
Return to the SRM console (DEC OSF/1 and OpenVMS systems only) and restart the system.	Refer to step 4 of the "Starting the ECU" section for operating system instructions.

Configuring EISA/ISA Options

ISA modules are configured manually, whereas EISA modules are configured through the ECU software (automatically). Refer to Table 4–3 for a summary of steps to configure an EISA bus *that contains both* EISA and ISA options. Review the “Before Running the ECU” section presented earlier in this chapter. Then run the ECU as described in the “Starting the ECU” section also presented earlier in this chapter.

Configuring EISA/ISA Options

Table 4–3 Summary of Procedure for Configuring EISA Bus with ISA Options

Step	Explanation
Install or move the EISA option. Do not install the ISA boards.	Use the instructions provided with the EISA option. ISA boards are installed <i>after</i> the configuration process is complete.
Power up and run the ECU.	If you have installed an EISA option, the ECU will need to locate the CFG file for that option. The CFG file for the option may reside on a configuration diskette packaged with the option or may be included on the System Configuration Diskette.
Add the ISA board to the configuration list.	Use the Add or Remove Boards ECU option to add the CFG file for the ISA option and to select an acceptable slot for the option. The CFG file for the option may reside on a configuration diskette packaged with the option or may be included on the System Configuration Diskette. If the CFG file for the ISA option <i>cannot</i> be found, select the generic CFG file for ISA options from the configuration diskette.
View or edit details (optional).	The View or Edit Details ECU option is used to change user-selectable settings or to change the resources allocated for these functions (IRQs, DMA channels, I/O ports, and so on). This step is not required when using the board's default settings.
Examine and set the required switches to match the displayed settings.	The Examine Required Switches ECU option displays the correct switch and jumper settings that must be physically set for each ISA option. Although the ECU cannot detect or change the settings of ISA boards, it uses the information from the previous step to determine the correct switch settings for these options. Physically set the board's jumpers and switches to match the required settings.
Save your configuration.	The Save and Exit ECU option saves your configuration information to the system's nonvolatile memory.
Return to the SRM console (DEC OSF/1 and OpenVMS systems only) and turn off the system.	Refer to step 4 of the "Starting the ECU" section for information about returning to the console.
Install the ISA board and turn on the system.	Use the instructions provided with the ISA option.

PCI Bus Options

PCI (Peripheral Component Interconnect) is an expansion I/O bus and is the preferred bus for high-performance I/O options. Your system supports 32-bit PCI options.

The PCI bus is shown in Figure 4-1. There are currently three slots reserved for 32-bit PCI options. A PCI board is shown in Figure 4-4.

Install PCI boards according to the instructions supplied with the option. PCI boards require no additional configuration procedures; the system automatically recognizes the boards and assigns the appropriate system resources.

Warning

Before installing a PCI option, turn off all power to the system (both ac and dc). Refer to the “Turning the System Off” section in Chapter 3.



Warning: For protection against fire, use only modules with current-limited outputs.

PCI Bus Options

Figure 4-4 PCI Board

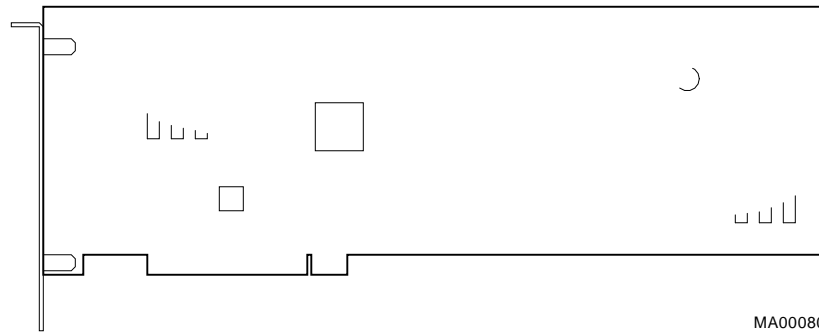

SCSI Buses

A SCSI bus expansion port on the rear of the system allows extension of the bus that runs through the removable-media mass-storage compartment to the outside of the system. As a result, the external mass-storage devices can be connected to the buses inside the system.

A Fast SCSI-2 adapter on the standard I/O module provides a single-ended SCSI bus for the system.

All tabletop or rackmounted SCSI-2 devices are supported through EISA- or PCI-based SCSI adapters. Use the following rules to determine if a device can be used on your system:

- The device must be supported by the operating system. Consult the software product description or hardware vendor.
- No more than seven devices can be on any one SCSI-2 controller, and each must have a unique SCSI ID.
- The entire SCSI bus length, from terminator to terminator, must not exceed 6.0 m (19.8 ft) for single-ended SCSI-2 at 5 MB/s, or 3.0 m (9.9 ft) for single-ended SCSI-2 at 10 MB/s.

For an AlphaServer 2100 CAB system, the internal cabling for the removable-media bus is 2.0 m (6.6 ft); therefore, the maximum length for external expansion is 4.0 m (13.2 ft).

Internal SCSI Bus

The Fast SCSI-2 adapter on the standard I/O module supports the following internal SCSI devices:

- One or two hard-disk drives and up to two 13.3-cm (5.25-in.) half-height devices.

This bus can be extended to a rackmounted StorageWorks shelf or to an external expander to support up to seven drives.

**Installing
Removable
Media Storage
Devices**

Warning

Before installing a storage device, turn off all power to the system (both AC and DC). Refer to the “Turning the System Off” section in Chapter 3.

To install a removable media device, refer to Figure 4–5 and proceed as follows:

1. Remove the front bezel as described in the “Removing and Replacing the Front Bezel” section in Chapter 2.
2. Turn off all power to the system (both AC and DC). Refer to the “Turning the System Off” section in Chapter 3.

Warning

Before performing the next step, fully extend the cabinet stabilizer bar. Adjust the foot at the end of the stabilizer bar until it touches the floor.

3. Remove the four 10-32 screws securing the system to the front cabinet rails and pull the system out of the cabinet.
4. Remove the top-front access cover shown in Figure 1–6.
5. Locate bracket holes A and B. For RRD n n or TLZ0 n , use bracket holes A. For TZK11 drives use bracket holes B.
6. Attach the bracket ❶ to the drive ❷ using four M3 x 6 mm flat-head screws ❸ and the appropriate bracket holes (A or B).
7. Set the device’s node ID so that there are no duplicate node IDs, as each device must have a unique node ID. Nodes 0–6 are available for drives, and node 7 is reserved for the host adapter. Refer to the device documentation on how to set the node ID on the device.
8. Insert the drive ❷ with the attached bracket into the appropriate slot and connect the drive cables ❹.
9. Secure the drive to the front of the system using two captive screws ❺.

10. Push the system back into the cabinet. Replace and tighten the four 10-32 screws.

Figure 4-5 Installing Removable Media

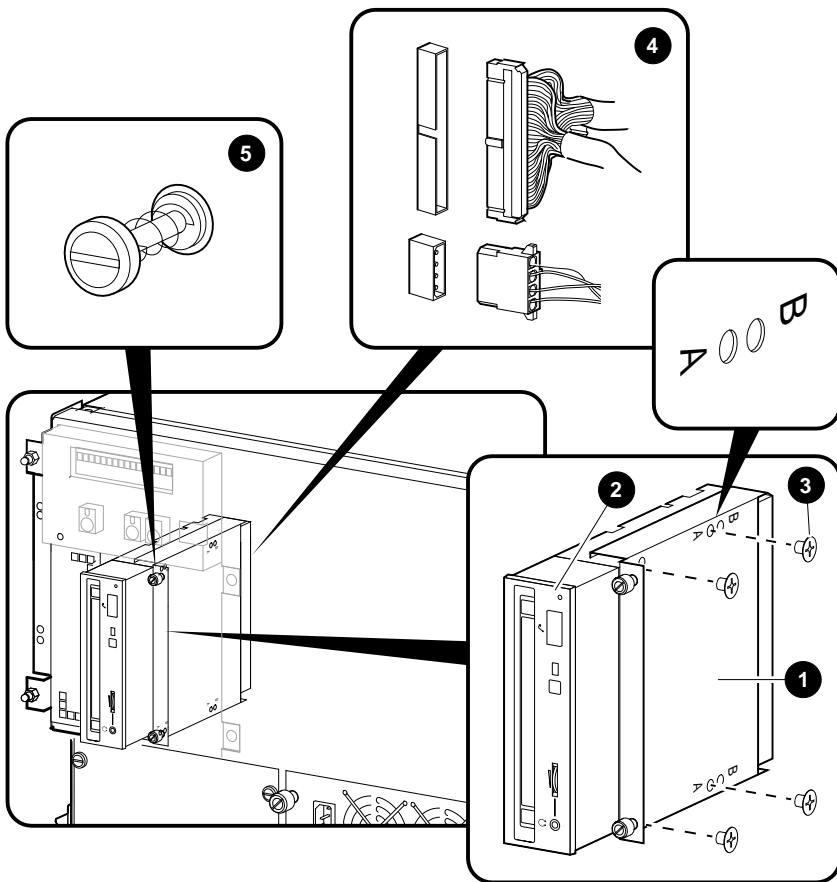

LJ-03844-T10

Installing a Hard-Disk Drive

To install a hard-disk drive, refer to Figure 4–6 and proceed as follows:

1. Remove the front bezel as described in the “Removing and Replacing the Front Bezel” section in Chapter 2.
2. Turn off all power to the system (both AC and DC). Refer to the “Turning the System Off” section in Chapter 3.

Warning

Before performing the next step, fully extend the cabinet stabilizer bar. Adjust the foot at the end of the stabilizer bar until it touches the floor.

3. Remove the four 10-32 screws securing the system to the front cabinet rails and pull the system out of the cabinet.
4. Remove the top-front access cover shown in Figure 1–6.
5. Locate the four rubber grommets ❶ in the accessories kit.
6. Screw the four rubber grommets ❶ into the drive ❷.
7. Push the drive into the appropriate keyhole openings ❸ of the mounting bracket ❹ and push to the left (when facing the system) until the locking tab ❺ snaps into place.
8. Connect the drive cables ❻.
9. Push the system back into the cabinet. Replace and tighten the four 10-32 screws.

Figure 4-6 Installing a Hard-Disk Drive

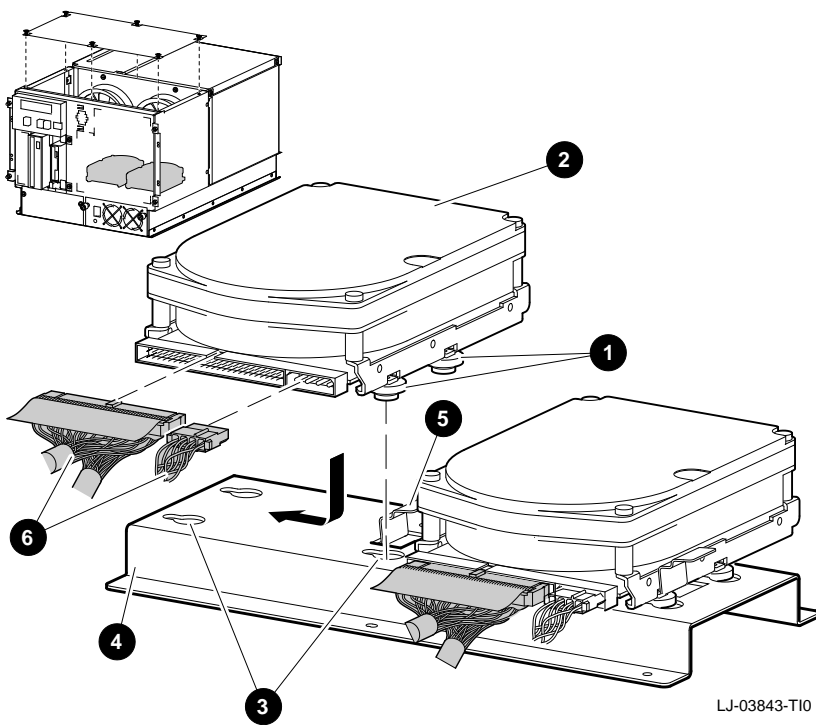

Power Supply Configurations

Warning

Before installing a power supply, turn off all power to the system (both AC and DC). Refer to the “Turning the System Off” section in Chapter 3.

A second power supply can be added to the rackmount system to provide a redundant power supply (refer to Figure 4–7). In most cases with a redundant power supply, the failure of one power supply does not cause the system to shut down. Normal operation continues with no impact on the system.

Figure 4-7 Power Supply Configurations

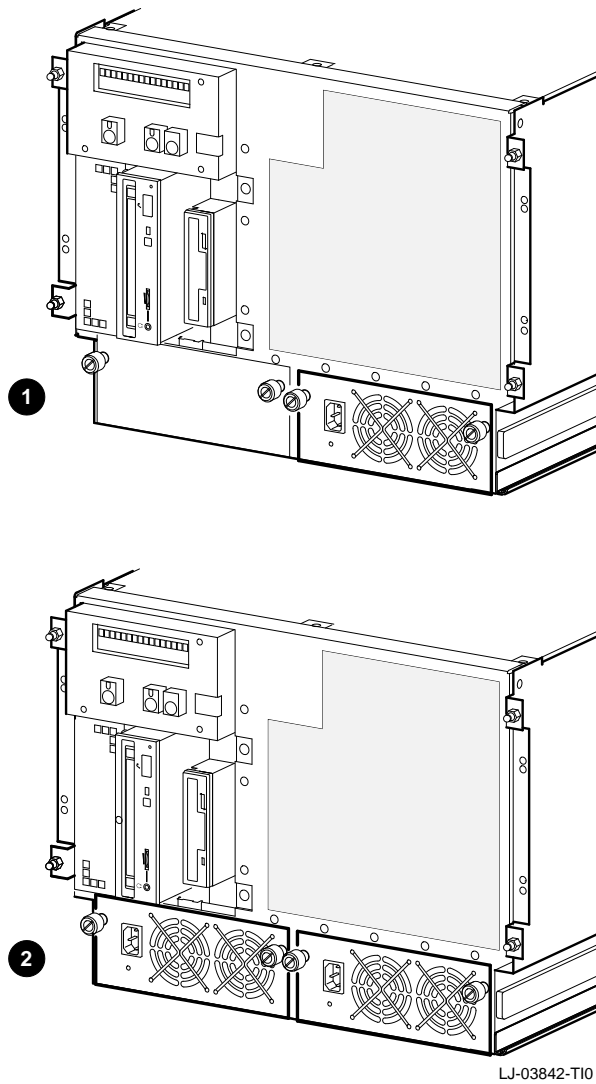

- ❶ System with a single power supply
- ❷ System with a redundant power supply

Console Port Configurations

Power-up information is typically displayed on your console terminal. Your console terminal may be either a graphics terminal or a serial terminal (one that is connected to your system through the COM1 serial communication port). The setting of the `console` environment variable determines where the system displays power-up output. Set this environment variable according to the console terminal that you are using.

Synopsis:

```
set console output_device
```

Arguments:

<code>graphics</code>	Displays the power-up output to a graphics terminal or to a device connected to the VGA module at the rear of the system.
<code>serial</code>	Displays the power-up output to a device connected to the COM1 serial communication port at the rear of the system.

Example:

```
>>> set console serial
>>>
```

5

System Troubleshooting

In This Chapter

This chapter provides troubleshooting information and covers the following topics:

- Determining the Service Provider
- Task Overview
- Determining the Type of Problem
- Reporting Problems
- Power Problems
- Problems Getting to Console Mode
- Interpreting the Operator Control Panel Power-Up /Diagnostic Display
- Console Reported Problems
- Mass-Storage Problems Indicated at Power-Up
- EISA Bus Problems Indicated at Power-Up
- PCI Bus Problems Indicated at Power-Up
- Boot Problems
- Operating System Reported problems
- Fail-Safe Loader

Determining the Service Provider

Determine the Service Provider

Before servicing the system, be aware of any service agreement that exists for your system. The agreement helps determine the level of maintenance for self-maintenance customers.

- For self-maintenance customers, use the information in this chapter to help identify and resolve the problem. Refer to the *AlphaServer 2000/2100/2100 RM/2100 CAB Series Service Guide* for more comprehensive troubleshooting information.
- If there is a service agreement with Digital, contact your Digital service representative for assistance.

Considerations Before Troubleshooting

Before troubleshooting any system problem, check the site maintenance log for the system's service history. Be sure to ask the system manager the following questions:

- Has the system been used before and did it work correctly?
- Have changes to hardware or updates to firmware or software been made to the system recently?
- What is the state of the system—is the operating system running?

If the operating system is down and you are not able to bring it up, use the console environment diagnostic tools, such as the power-up/diagnostic displays and ROM-based diagnostics (RBDs).

If the operating system is running, use the operating system environment diagnostic tools, such as error logs, crash dumps, and exercisers (DEC VET).

Identifying Problems

Table 5–1 lists ways to identify problems and indicates where each method is described.

Table 5–1 How to Identify a Problem

Method	Reference
Using the troubleshooting tables	This chapter
Running diagnostic tests	test command, or show fru command as described in the “Console Reported Problems” section in this chapter.

Note

If you are running Windows NT, you must switch from the ARC to the SRM console before you can run the test command. For information about switching to the SRM console, refer to the “Switching from ARC to SRM” section in Chapter 3.

Task Overview

Identifying and Resolving Problems

Table 5–2 describes the steps required to identify and resolve system problems.

Table 5–2 Identifying and Resolving Problems

Step	Description
1	Determine the type of problem.
2	Locate the problem in the troubleshooting tables.
3	Follow the suggested actions to resolve the problem.
4	If necessary, run the diagnostic tests.
5	Contact your Digital service representative or other maintenance provider.

The next sections describe these steps in detail.

Determining the Type of Problem

Types of System Problems

Determine the type of problem that your system is experiencing from the list in Table 5–3.

Table 5–3 Problem Reference

Problem	Section
The system powers down unexpectedly or does not power up.	Power Problems
The power-up screens are not displayed on the console terminal.	Problems Getting to Console Mode
The power-up screens report an error or do not complete.	Console Reported Problems
The system cannot find the boot device or the device does not boot.	Boot Problems
The operating system startup screen does not appear, software applications do not run, or the operating system reports an error.	Operating System Reported Problems

If the system has a problem that is not listed in Table 5–3 or the corrective actions in the troubleshooting tables do not resolve the problem, refer to the “Reporting Problems” section in this chapter.

Reporting Problems

Precall Checklist

If you are unable to locate the system problem as outlined in Table 5–3, or the corrective actions suggested in the troubleshooting tables in this chapter do not resolve the problem, contact the nearest Digital support center. Before calling to report a problem, complete the following steps:

1. Locate the part and serial numbers printed on the label at the rear of your system. Record these numbers on a copy of the AlphaServer 2100 CAB system Problem Worksheet presented later in this chapter.
The Digital support center will need this information when you call.
2. Fill in the Status of the System information on the worksheet.
3. Note the problem, any known possible causes, and the corrective actions suggested in the troubleshooting tables. Also indicate what corrective actions (if any) have already been taken to try to resolve the problem.
4. Be prepared to read information from the screen and to enter commands at the keyboard while you talk to the Digital support center representative.

Digital Support Center Contact Numbers

Table 5–4 lists the telephone numbers for contacting your Digital support center.

If your Digital support center number is not listed in Table 5–4, contact your local Digital office for assistance.

Table 5-4 Digital Support Centers

Country	Telephone Number
UNITED STATES	1-800-354-9000
Colorado Springs, CO	
From U.S./Canada/Mexico	719-592-7000
Shrewsbury, MA	
From U.S./Canada/Mexico	508-841-3700
Alpharetta, GA	
From U.S./Canada/Mexico	404-343-0000
AUSTRALIA	31-2-5615252
AUSTRIA	0222-86630-555
BELGIUM	02-7297744
CANADA	
English	1-800-267-5251
French	1-800-267-2603
DENMARK	80301005
FINLAND	90 9800 2878
FRANCE	1-69874123
GERMANY	01307702
HONG KONG	852-4149779
ISRAEL	052-592-300
ITALY	2-1678 20062
JAPAN (Tokyo)	
Trouble	0120-113035 (toll-free)
SPS Telephone Support	0120-113036 (toll-free)
Commodity Products Phone	0120-206042 (toll-free)
Special Account Customers	0120-113334 (toll-free)
Windows NT Hot Line	03-3207-2881

(continued on next page)

Reporting Problems

Table 5–4 (Cont.) Digital Support Centers

Country	Telephone Number
KOREA	82-2-7991114
MALAYSIA	60-3-2300111
MEXICO	520140810017
NETHERLANDS	030-832888
NORTHERN IRELAND	0232 381381
NORWAY	02-256300
PHILIPPINES	623-810-5156
PORTUGAL	
LISBON	01-3877051
OPORTO	02-6068805
PUERTO RICO	800-981-4764
REPUBLIC OF IRELAND	01-381216
SINGAPORE	330-6225
SPAIN	
MADRID	34-(9)1-5834257
BARCELONA	34-(9)3-4012222
SWEDEN	08-988835
THAILAND	66-254-8191
UNITED KINGDOM	025 6-59200

AlphaServer 2100 CAB Problem Worksheet

DEC service representative telephone number: _____

Serial Number: _____

Status of the System (check all that apply):

- | | |
|---|--|
| <input type="checkbox"/> DC power light is not on | <input type="checkbox"/> Console program fails to boot |
| <input type="checkbox"/> OCP power/diagnostic display failure message | <input type="checkbox"/> Console error message |
| <input type="checkbox"/> Operating system fails to boot | <input type="checkbox"/> Diagnostic test error message |

OCP powerup/diagnostic display:

Screen error message:

Troubleshooting notes:

LJ-03805-T10C

Power Problems

This section describes how to troubleshoot the system when there is no power at the system enclosure or the power supply subsystem lights indicate power problems.

Table 5–5 describes possible power problems and their corrective actions.

Table 5–5 Diagnostic Flow for Power Problems

Symptom	Corrective Action
The fans do not spin up when the AC power cable is plugged into the power supply.	Check the power source and the power cord. If there are two power supplies, make sure that both are plugged in.
AC power is present, as indicated by the spinning fans, but the system does not power on.	Check the DC On/Off button setting on the OCP. Check that the ambient room temperature is within the environmental specifications (10°C–40°C (50°F–104°F)).
The power supply shuts down after approximately 5 seconds.	Check to see if both 6.75-inch fans are operating. A failure of either 6.75-inch fan causes the system to shut down after approximately 5 seconds.

Problems Getting to Console Mode

This section describes how to troubleshoot when powering up the system, but the console terminal does not display the power-up screen.

Table 5–6 describes possible problems getting to console mode and their corrective actions.

Table 5–6 Diagnostic Flow for Problems Getting to Console Mode

Symptom	Corrective Action
The power-up screen is not displayed.	<p>Check the power-up/diagnostic display on the OCP (refer to Table 3–1) for a failure during self-tests.</p> <p>Check that the keyboard and monitor are properly connected and powered on (refer to the “Connecting the Terminal ” section in Chapter 2).</p> <p>If the power-up screen is not displayed, and the system enters console mode, check that the console environment variable is set correctly. If a VGA console terminal is used, set the variable to graphics. If a serial terminal is used, set the variable to serial.</p> <p>If console is set to serial, the power-up screen is routed to the COM1 serial communication port (refer to the set console command in Chapter 1 of the <i>AlphaServer 2000/2100 Firmware Reference Guide</i>) and cannot be viewed from the VGA monitor.</p> <p>Try connecting a console terminal to the COM1 serial communication port (refer to the “Connecting the Terminal ” section in Chapter 2). If necessary use a 9-pin connector. Check the baud rate setting for the console terminal and system. The system baud rate setting is 9600. When using the COM1 port, set the console environment variable to serial.</p>

Interpreting the Operator Control Panel Power-Up/Diagnostic Display

Table 5–7 describes how to interpret messages that may be displayed on the power-up/diagnostic display located on the operator control panel on the front of the system (shown in Figure 3–1).

Table 5–7 Interpreting the Operator Control Panel Power-Up/Diagnostic Display

Message	Meaning
TEST	This is displayed while the system executes diagnostic tests and exercisers. The type of module under test, its slot number, and the currently executing test number are also displayed.
FAIL	<p>If an error is detected, a failure message is displayed (and the Halt button LED lights) for a few seconds. The error is logged to the appropriate module through the serial control bus. In nearly all cases, the power-up tests continue.</p> <p>The module type and the slot number for the field replaceable unit (FRU) that failed, along with the test number that detected the error, are also displayed.</p> <p>The module types and slot numbers are as follows:</p> <ul style="list-style-type: none"> CPU_{nn} — CPU modules (0–3) MEM_{nn} — Memory modules (0–3) I/O_0 — Standard I/O module I/O_1 — Extended I/O module (PCI) PCI_{nn} — PCI modules (0–2) EISA_{nn} — EISA modules (1–8) MBD — Motherboard
CPU STATUS	<p>Summary of CPU testing—The status of each CPU from right to left, starting with CPU0 is displayed:</p> <ul style="list-style-type: none"> “P” — CPU passed “F” — CPU failed “_” — CPU not present
STARTING CPU #	The console is starting the primary CPU.

(continued on next page)

Table 5–7 (Cont.) Interpreting the Operator Control Panel Power-Up/Diagnostic Display

Message	Meaning
SYSTEM RESET	The Reset button has been pressed.
Model X/XX	When the system is under operating system control, the CPU variant and system model number are displayed unless you supply your own text using the ocp_text environment variable.

Failing SIMMs Reported on Power-Up Display

For the AlphaServer 2100 CAB system, which uses single-inline memory modules (SIMMs), serial ROM power-up tests will terminate if one bank of good memory is not detected and the console firmware cannot be loaded. The first two data bits of bad memory (in hexadecimal) are displayed along with the FAIL MEM_nn display on the operator control panel.

Using Table 5–8 you can find the corresponding SIMM position on the memory carrier module for the failing data bits.

For example; the following operator control panel power-up display message indicates a bad SIMM at position J28.

```
FAIL MEM_00 01
```

The following operator control panel power-up display message indicates two bad SIMMs at positions J33 and J34.

```
FAIL MEM_00 1718
```

After determining the bad SIMMs, refer to the *AlphaServer 2000 /2100/2100 RM/2100 CAB Series Service Guide* for instructions on replacing FRUs for the AlphaServer 2100 CAB system.

Note

Only two bad memory data bits at a time are captured by the system diagnostics. If more than two SIMMs are bad, you must repeat the SIMM isolation and replacement procedures until all bad SIMMs are replaced.

Table 5–8 Memory Data Bits in Error and Corresponding SIMM Position

Bit in Error–Failing SIMM							
00-J28	20-J28	40-J28	60-J32	80-J28	A0-J28	C0-J28	E0-J32
01-J28	21-J28	41-J28	61-J32	81-J28	A1-J28	C1-J28	E1-J32
02-J28	22-J28	42-J29	62-J32	82-J28	A2-J28	C2-J29	E2-J32
03-J28	23-J28	43-J29	63-J32	83-J28	A3-J28	C3-J29	E3-J32
04-J29	24-J29	44-J30	64-J33	84-J29	A4-J29	C4-J30	E4-J33
05-J29	25-J29	45-J30	65-J33	85-J29	A5-J29	C5-J30	E5-J33
06-J29	26-J29	46-J31	66-J33	86-J29	A6-J29	C6-J31	E6-J33
07-J29	27-J29	47-J31	67-J33	87-J29	A7-J29	C7-J31	E7-J33
08-J30	28-J30	48-J32	68-J34	88-J30	A8-J30	C8-J32	E8-J34
09-J30	29-J30	49-J32	69-J34	89-J30	A9-J30	C9-J32	E9-J34
0A-J30	2A-J30	4A-J33	6A-J34	8A-J30	AA-J30	CA-J33	EA-J34
0B-J30	2B-J30	4B-J33	6B-J34	8B-J30	AB-J30	CB-J33	EB-J34
0C-J30	2C-J31	4C-J34	6C-J35	8C-J31	AC-J31	CC-J34	EC-J35
0D-J30	2D-J31	4D-J34	6D-J35	8D-J31	AD-J31	CD-J34	ED-J35
0E-J30	2E-J31	4E-J35	6E-J35	8E-J31	AE-J31	CE-J35	EE-J35
0F-J30	2F-J31	4F-J35	6F-J35	8F-J31	AF-J31	CF-J35	EF-J35
10-J32	30-J32	50-J28	70-J28	90-J32	B0-J32	D0-J28	F0-J28
11-J32	31-J32	51-J28	71-J28	91-J32	B1-J32	D1-J28	F1-J28
12-J32	32-J32	52-J28	72-J28	92-J32	B2-J32	D2-J28	F2-J28
13-J32	33-J32	53-J28	73-J28	93-J32	B3-J32	D3-J28	F3-J28
14-J33	34-J33	54-J29	74-J29	94-J33	B4-J33	D4-J29	F4-J29
15-J33	35-J33	55-J29	75-J29	95-J33	B5-J33	D5-J29	F5-J29
16-J33	36-J33	56-J29	76-J29	96-J33	B6-J33	D6-J29	F6-J29
17-J33	37-J33	57-J29	77-J29	97-J33	B7-J33	D7-J29	F7-J29
18-J34	38-J34	58-J30	78-J30	98-J34	B8-J34	D8-J30	F8-J30
19-J34	39-J34	59-J30	79-J30	99-J34	B9-J34	D9-J30	F9-J30

(continued on next page)

Interpreting the Operator Control Panel Power-Up/Diagnostic Display

Table 5–8 (Cont.) Memory Data Bits in Error and Corresponding SIMM Position

Bit in Error–Failing SIMM							
1A-J34	3A-J34	5A-J30	7A-J30	9A-J34	BA-J34	DA-J30	FA-J30
1B-J34	3B-J34	5B-J30	7B-J30	9B-J34	BB-J34	DB-J30	FB-J30
1C-J35	3C-J35	5C-J31	7C-J31	9C-J35	BC-J35	DC-J31	FC-J31
1D-J35	3D-J35	5D-J31	7D-J31	9D-J35	BD-J35	DD-J31	FD-J31
1E-J35	3E-J35	5E-J31	7E-J31	9E-J35	BE-J35	DE-J31	FE-J31
1F-J35	3F-J35	5F-J31	7F-J31	9F-J35	BF-J35	DF-J31	FF-J31

Console Reported Problems

This section describes how to troubleshoot the system when self-tests do not complete or when error messages are displayed on your console terminal in console mode.

Table 5–9 describes possible problems reported by the console program and their corrective actions.

Table 5–9 Diagnostic Flow for Problems Reported by the Console Program

Symptom	Corrective Action
The power-up tests do not complete.	Use the power-up/diagnostic display on the OCP (refer to Table 3–1).
The system powers up to the ash> prompt.	Reinstall the firmware. Refer to the firmware update documentation for firmware installation instructions. Contact your Digital support center if there is no backup copy of the firmware.
The console program reports an error.	Use the power-up/diagnostic display on the OCP (refer to Table 3–1) to determine the error.
The OCP displays failure message at power-up.	Use the show fru command described in the next section to see if errors have been logged.
The Halt button LED lights during power-up.	Examine the console event log (enter the cat el command) or power-up screens to check for embedded error messages recorded during power-up.
The power-up screen includes error messages.	<p>If the power-up screens or the console event log indicate problems with mass-storage devices, or if the storage devices are missing from the show config display, use Table 5–10 and Table 5–11 to determine the problem.</p> <p>If the power-up screens or the console event log indicate problems with the EISA devices, or if the EISA devices are missing from the show config display, use Table 5–13 to determine the problem.</p> <p>If the power-up screens or the console event log indicate problems with the PCI devices, or if the PCI devices are missing from the show config display, use Table 5–14 to determine the problem.</p>

(continued on next page)

Table 5–9 (Cont.) Diagnostic Flow for Problems Reported by the Console Program

Symptom	Corrective Action
	Run the test command (described later in this chapter) to verify the problem.

show fru

The `show fru` command reports module and error information for the following field replaceable units based on the serial control bus EEPROM data:

- CPU modules
- Memory modules
- I/O modules

For each of the modules, the slot position, option, part, revision, and serial numbers, as well as any reported symptom-directed diagnostics (SDD) and test-directed diagnostics (TDD) event logs are displayed.

In addition, installed PCI and EISA modules are displayed with their respective slot numbers.

Console Reported Problems

Synopsis:

show fru

Example:

P00>>> show fru

① Slot	② Option	③ Part#	④ Rev		⑤ Serial#	⑥ Events logged	
			Hw	Sw		SDD	TDD
0	I/O	B2110-AA	C4	0	KA349EVM30	00	00
1	CPU2	B2020-AA	A3	0	ML33800033	00	00
2	CPU0	B2020-AA	A3	0	ML33900059	00	00
3	CPU1	B2020-AA	A3	0	ML33800035	00	00
5	CPU3	B2020-AA	A3	0	ML33900050	00	00
6	MEM2	B2021-BA	A0	0	GA33602844	00	00

PCI Bus		Option Name
Hose	Slot	
0	8	NCR 53C810

EISA Bus		Option Name
Hose	Slot	
1	1	MLX0075
1	2	DEC2E00
1	3	CPQ3011
1	5	DEC4220
1	6	MLX0072

P00>>>

- ① System bus slot number for module (slots 0–7 top to bottom)
 - Slot 0: Standard I/O module (dedicated EISA/PCI card-cage slot)
 - Slot 1–3, 5: CPU modules
 - Slot 4–7: Memory modules
- ② Option name (I/O, CPU#, or MEM#)
- ③ Part number of option
- ④ Revision numbers (hardware and firmware)
- ⑤ Serial number

Console Reported Problems

⑥ Events logged:

Numbers other than “00” indicate that errors have been logged.

- SDD: Number of symptom-directed diagnostic events logged by the operating system, or in the case of memory, by the operating system and firmware diagnostics.
- TDD: Number of test-directed diagnostic events logged by the firmware diagnostics.

test

The `test` command runs firmware diagnostics for the core system. The tests are run sequentially and the status of each subsystem test is displayed on the console terminal as the tests progress. If a particular device is not available to test, a message is displayed.

Note

By default, no write tests are performed on disk and tape drives. Media must be installed to test the floppy drive and tape drives.

The `test` script tests devices in the following order:

1. Memory tests (one pass)
2. Read-only tests: DK* disks, DR* disks, DU* disks, MK* tapes, DV* floppy
3. Console loopback tests if `lb` argument is specified: COM2 serial port and parallel port

Console Reported Problems

4. VGA console tests—These tests are run only if the VGA terminal is not used as the console terminal; that is, the console environment variable is set to serial.
5. Network external loopback tests for EWA0—This test requires that the Ethernet port be terminated or connected to a live network, otherwise, the test will fail.

Synopsis:

test [lb]

Arguments:

[lb] The loopback option includes console loopback tests for the COM2 serial port and the parallel port during the test sequence.

Example:

```
>>> test
 2:32:12 March 4, 1994
Testing the Memory
Testing the DK* Disks(read only)
dkb600.6.0.2.1 has no media present or is disabled via the
RUN/STOP switch
file open failed for dkb600.6.0.2.1
No DR* Disks available for testing
Testing the MK* Tapes(read only)
Testing the DV* Floppy Disks(read only)
file open failed for dva0.0.0.0.1
Testing the VGA(Alphanumeric Mode only)
Testing the EW* Network
 2:33:15 March 4, 1994
>>>
```

Mass-Storage Problems Indicated at Power-Up

Mass-storage failures at power-up are usually indicated by read fail messages. Other problems can result in storage devices missing from the `show config` display.

Table 5–10 provides information for troubleshooting fixed-media mass-storage problems indicated at power-up.

Table 5–11 provides information for troubleshooting removable-media mass-storage problems indicated at power-up.

Use these tables to diagnose the likely cause of the problem.

Mass-Storage Problems Indicated at Power-Up

Table 5–10 Fixed-Media Mass-Storage Problems

Problem	Symptom	Corrective Action
A drive failure.	The fault LED for the drive is on (steady).	Replace the drive.
There are duplicate SCSI IDs (when removable-media bus is extended to StorageWorks shelf).	The drives with duplicate SCSI IDs are missing from the show config display.	Correct the removable-media SCSI IDs.
The SCSI ID(s) is set to 7 (reserved for host ID).	The valid drives are missing from the show config display. One drive may appear seven times on the show config display.	Correct the SCSI IDs.
There are duplicate host IDs on a shared bus.	The valid drives are missing from the show config display. One drive may appear seven times on the show config display.	Change the host IDs using the set pk*0_host_id command described in Chapter 1 of the <i>AlphaServer 2000/2100 Firmware Reference Guide</i> .
An I/O module failure (if removable-media bus is extended to StorageWorks shelf) or PCI or EISA storage adapter option failure.	Problems persist after eliminating the previous problem sources.	Replace the standard I/O or storage adapter module.

Mass-Storage Problems Indicated at Power-Up

Table 5–11 Removable-Media Mass-Storage Problems

Problem	Symptom	Corrective Action
A drive failure.	The fault LED for the drive is on (steady).	Replace the drive.
There are duplicate SCSI IDs.	The drives with duplicate SCSI IDs are missing from the show config display.	Correct the SCSI IDs.
The SCSI ID(s) is set to 7 (reserved for host ID).	The valid drives are missing from the show config display. One drive may appear seven times on the show config display.	Correct the SCSI IDs.
There are duplicate host IDs on a shared bus.	The valid drives are missing from the show config display. One drive may appear seven times on the show config display.	Change the host IDs using the set pk*0_host_id command described in Chapter 1 in the <i>AlphaServer 2000/2100 Firmware Reference Guide</i> .
There are missing or loose cables.	The activity LEDs do not come on. The drive is missing from the show config display.	Remove the device and inspect the cable connections.
A terminator is missing.	There are read/write errors in the console event log; the storage adapter port may fail.	Attach terminators as needed: internal SCSI terminator (12-41296-01) or external SCSI terminator (12-37004-04).
There is an I/O module failure.	Problems persist after eliminating the previous problem sources.	Replace the standard I/O module.

Mass-Storage Problems Indicated at Power-Up

Table 5–12 Troubleshooting RAID Problems

Symptom	Action
Some RAID drives do not appear on the show device d display.	Valid configured RAID logical drives will appear as DRA0–DRAn, not as DKn. Configure the drives by running the RAID Configuration Utility (RCU), following the instructions in the <i>StorageWorks RAID Array 200 Subsystem Family Installation and Configuration Guide</i> , EK-SWRA2-IG. Reminder: several physical disks can be grouped as a single logical DRAn device.
Drives on the RAID subsystem power up with the amber Fault light on.	Whenever you move drives onto or off of the SWXCR-Ex controller, run the RAID Configuration Utility to set up the drives and logical units. Follow the instructions in the <i>StorageWorks RAID Array 200 Subsystem Family Installation and Configuration Guide</i> .
Image copy of DRA logical drive does not boot (OpenVMS systems).	If you copy the contents of a system disk to your RAID subsystem using the BACKUP/IMAGE command, for example, you need to repeat several steps in the data device installation procedure, as described in the <i>StorageWorks RAID Array 200 Subsystem Family Software User's Guide for OpenVMS AXP</i> , AA-Q6WVA-TE, in order to make the second device a bootable device.
Cannot access disks connected to the RAID subsystem on Windows NT systems.	On Windows NT systems, disks connected to the SWXCR-Ex controller must be spun up before they can be accessed. While running the ECU, verify that the controller is set to spin up two disks every six seconds. This is the default setting if you are using the default configuration files for the controller. If the settings are different, adjust them as needed.

EISA Bus Problems Indicated at Power-Up

EISA bus failures at power-up are usually indicated by the following messages displayed during power-up:

EISA Configuration Error. Run the EISA Configuration Utility.

Run the ECU. Refer to the “Configuring EISA and ISA Options” section in Chapter 4 when such a message is displayed. Other problems are indicated by EISA devices missing from the show config display.

Table 5–13 provides information for troubleshooting EISA bus problems that persist after running the ECU.

EISA Bus Problems Indicated at Power-Up

Table 5–13 EISA Troubleshooting

Step	Corrective Action
1	Confirm that the EISA module and any cabling are properly seated.
2	Run the ECU to: <ul style="list-style-type: none">• Confirm that the system has been configured with the most recently installed controller.• Determine what the hardware jumper and switch setting should be for each ISA controller.• Determine what the software setting should be for each ISA and EISA controller.• Determine if the ECU deactivated (<>) any controllers to prevent a conflict.• Determine if any controllers are locked (!), which limits the ECU's ability to change resource assignments.
3	Confirm that the hardware jumpers and switches on ISA controllers reflect the settings indicated by the ECU. Start with the last ISA module installed.
4	Check for a bad slot by moving the last installed controller to a different slot.
5	Call the option manufacturer or the Digital support center for help.

EISA Bus Problems Indicated at Power-Up

Additional EISA Troubleshooting Tips

The following tips can aid in isolating EISA bus problems:

- Peripheral device controllers need to be seated (inserted) carefully, but firmly, into their slot to make all necessary contacts. Improper seating is a common source of problems for EISA modules.
- The CFG files supplied with the option that you want to install may not work on AlphaServer 2100 systems. Some CFG files call overlay files that are not required on this system or may reference inappropriate system resources, for example, BIOS addresses. Contact the option vendor to obtain the proper CFG file.
- Peripherals cannot share direct memory access (DMA) channels. Assignment of more than one peripheral to the same DMA channel can cause unpredictable results or even loss of function of the EISA module.
- Systems running Windows NT can assign shared interrupt lines (IRQs). DEC OSF/1 and OpenVMS do not allow shared interrupts.
- Not all EISA products work together. EISA is an open standard, and not every EISA product or combination of products can be tested. Violations of specifications may not matter in some configurations, but do matter in others.

Manufacturers of EISA options often test the most common combinations and may have a list of ISA and EISA options that do not function in combination with particular systems. Be sure to check the documentation or contact the option vendor for the most up-to-date information.

- EISA systems will not function unless they are first configured using the ECU.
- The ECU will not notify you if the configuration program diskette is write-protected when it attempts to write the system configuration file (system.sci) to the diskette.

PCI Bus Problems Indicated at Power-Up

PCI bus failures at power-up are usually indicated by the inability of the system to see the device. Use Table 5–14 to diagnose the likely cause of the problem.

Table 5–14 PCI Troubleshooting

Step	Corrective Action
1	Confirm that the PCI module and any cabling are properly seated.
2	Check for a bad slot by moving the last installed controller to a different slot.
3	Call the option manufacturer or the Digital support center for help.

Boot Problems

This section describes how to troubleshoot problems that occur while the system is booting the operating system software.

Table 5–15 describes possible problems during booting and their corrective actions.

Table 5–15 Diagnostic Flow for Boot Problems

Symptom	Corrective Action
System cannot find the boot device.	<p>Verify that your system recognizes the boot device, using the <code>show device</code> command. Refer to the “Verifying System Configuration ” section in Chapter 4.</p> <p>Check that the boot device environment variable correctly identifies the boot device:</p> <ul style="list-style-type: none"> • DEC OSF/1 and OpenVMS: See the <code>boot</code> command in the <i>AlphaServer 2000/2100 Firmware Reference Guide</i> • Windows NT: See the <code>FWSEARCHPATH</code> environment variable in the <i>AlphaServer 2000/2100 Firmware Reference Guide</i>
Device does not boot.	<p>Check that the Halt button is set to the “out” position.</p> <p>Run the <code>test</code> command. See the description in the section “Console Reported Problems”, earlier in this chapter.</p>

Operating System Reported Problems

This section describes how to troubleshoot system problems that occur while the operating system software is up and running.

Table 5–16 describes possible operating system problems and their corrective actions.

Table 5–16 Diagnostic Flow for Errors Reported by the Operating System

Symptom	Corrective Action
The system is hung or has crashed.	Examine the crash dump file. Refer to the <i>OpenVMS AXP Alpha System Dump Analyzer Utility Manual</i> for information on how to interpret OpenVMS crash dump files. Refer to the <i>Guide to Kernel Debugging</i> for information on using the DEC OSF/1 Krash Utility.
The operating system is up.	Have the Digital support center examine the operating system error log files to isolate the problem. Self-maintenance customers can refer to the <i>AlphaServer 2000/2100/2100 RM/2100 CAB Series Service Guide</i> . If the problem occurs intermittently, have the Digital support center run an operating system exerciser, such as the DEC VET, to stress the system. Refer to the <i>DEC Verifier and Exerciser Tool User's Guide</i> for instructions on running DEC VET.

Fail-Safe Loader

The fail-safe loader (FSL) allows you to power up without initializing drivers running power-up diagnostics.

Note

The fail-safe loader should be used only when a failure at power-up prohibits you from getting to the console program. You cannot boot an operating system from the fail-safe loader.

If a checksum error is detected when loading the SRM console at power-up, the fail-safe loader is automatically loaded into memory and the system displays the FSL prompt `ash>`. If the system automatically powers up to the `ash>` prompt, reinstall the firmware according to the instructions provided with the firmware.

Whenever the fail-safe loader console is activated, the power-up/diagnostic display on the OCP displays a `FAIL I/O_00` message.

The FSL permits you to get to a console, with limited functionality, when one of the following is the cause of a problem getting to the console program under normal power-up:

- A power failure or accidental power-down during a firmware upgrade
- An error in the nonvolatile nvram file
- An incorrect environment variable setting
- A driver error

Note

The FSL program, indicated by the `ash>` prompt, has limited functionality (a simple shell is indicated by the letters “ash” contained in the console prompt).

Fail-Safe Loader

Fail-Safe Loader Functions

From the FSL program, you can:

- Edit the nvram file (using the edit command).
- Assign a correct value to an environment variable (using the show and set commands).
- Start individual drivers using the `init -driver ew` command to start the Maintenance Operations Protocol (MOP) driver or `init -driver dv` to start the floppy driver. The `init -driver 6` command in FSL mode starts all available drivers.

Note

The nonvolatile file, nvram, is shipped from the factory with no contents. You can use the edit command to create a customized script or command file that is executed as the last step of every power-up.

Activating the Fail-Safe Loader

To activate the FSL, perform the following steps:

1. Install jumper J6 on the standard I/O module (refer to Figure 5-1). The jumper is stored on one of the pins of the J6 jumper.
2. Turn on the system.
3. Use the FSL program (indicated by the ash> prompt) to make corrections, edit the nvram file, set environment variables, or initialize phase 6 drivers.
4. When you have finished, power down and remove the FSL jumper.

Figure 5-1 Fail-Safe Loader Jumper (J6) on the Standard I/O Module

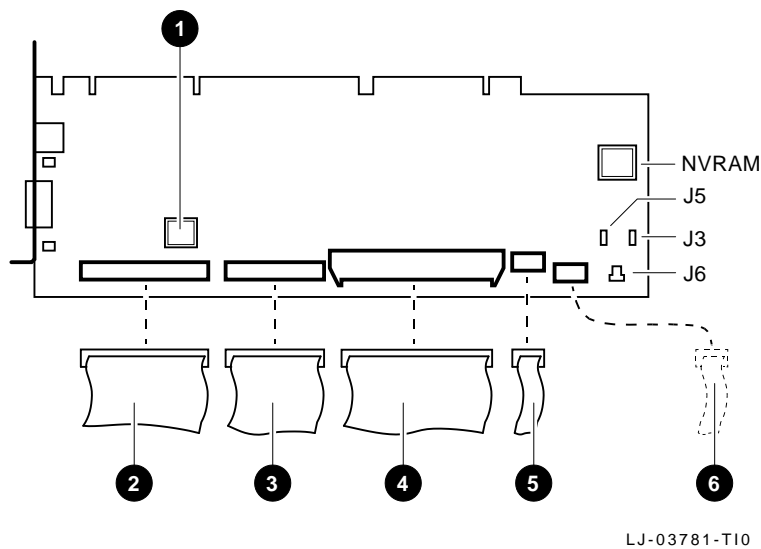

- ❶ Ethernet Address ROM (E72)
- ❷ SCSI (50-pin)
- ❸ Floppy (34-pin)
- ❹ Remote I/O (60-pin)
- ❺ OCP (10-pin)
- ❻ DSM Remote Option (16-pin)

Note

J3–Power supply mode: When installed, dual power supplies operate in redundant mode.

J5–Program voltage: Internal use only.

J6–Fail-safe: When installed, selects the fail-safe loader firmware.

NVRAM–Nonvolatile random-access memory.

Index

64-bit PCI, 4-9

A

AC power connector
location of, 1-8

Access door
left side
location of, 1-12

Adapter
Fast SCSI-2, 4-25

ARC boot selections
managing of, 3-1

ARC firmware
using the, 3-1

ARC interface
switching to SRM from, 3-11

Autoboot
DEC OSF/1, 3-19
OpenVMS, 3-19

B

Boot diagnostic flow, 5-29

Boot menu (ARC), 3-10

Boot problems
troubleshooting, 5-29

Boot procedure, 3-18
booting DEC OSF/1 automatically, 3-19
booting OpenVMS automatically, 3-19

Bus
expansion of, 2-32
system, 4-7

C

Caddy
See CD-ROM caddy

CD
See CD-ROM drive, 3-26

CD-ROM caddy
loading a disc into, 3-32

CD-ROM disc drive
inserting a disc into, 3-32

CD-ROM drive
components, 3-26, 3-28
inserting a disc into, 3-30
operating, 3-26
removing a disc from, 3-31, 3-32

CFG files, 5-27

COM2 and parallel port
loopback tests, 5-19

Commands
to examine system configuration, 4-5

Compact disc drive
operation of, 3-1

Configuration
See ECU
console port, 3-8
EISA boards, 4-19
EISA/ISA boards, 4-21

Configuration file (CFG), EISA and ISA,
4-15

Configuration rules
removable-media, 4-26

- Configuration, verifying
 - for DEC OSF/1, 4-5
 - for OpenVMS, 4-5
 - for Windows NT, 4-5
- Considerations
 - before troubleshooting, 5-2
- Console
 - diagnostic flow, 5-11
- Console commands
 - show fru, 5-17
 - test, 5-19
- Console device, connecting, 2-30
- console environment variable, 3-8
- Console mode
 - defined, 3-23
 - invoking, 3-23
 - invoking remotely, 3-23
 - invoking with Halt button, 3-23
 - problems, troubleshooting, 5-11, 5-16
 - prompt, 3-23
 - troubleshooting, 5-16
- Console output, 3-8, 4-32
- Console port configuration, 4-32
- Console port configurations, 3-8
- Console prompt, 3-23
 - SRM console, 3-9
- console terminal, 2-26
- Console terminal, 3-23
- Console, invoking
 - See Console mode, 3-23
- Consoles
 - switching between ARC and SRM, 3-11
- CPU, 4-8
- CPU failover, 3-12
- CPU module
 - installation requirements, 4-8
 - location of, 4-7
 - SMP configuration and, 4-8
- Customer support, 5-6, 5-7

D

- DAT tape drive
 - operating, 3-34
 - operation of, 3-1
- DC On/Off button, 1-9, 3-3
- DC On/Off light, 3-3
- Diagnostic flow
 - boot problems, 5-29
 - console, 5-11
 - console mode problems, 5-16
 - errors reported by operating system, 5-30
 - power problems, 5-10
 - problems getting to console mode, 5-11
 - problems reported by console, 5-16
- Disk drives
 - mounting, 3-25
- Door, OCP
 - opening of, 1-10
 - unlocking of, 1-10
- Dual power supply (redundant), 4-30

E

- ECU
 - actions after exiting, 4-18
 - defined, 4-15
 - invoking console firmware, 4-16
 - procedure for running, 4-16
 - procedures, 4-19
 - starting up, 4-16
- edit command, 5-32
- EISA, 1-6
- EISA boards
 - configuring, 4-19
- EISA boards, identifying, 4-14
- EISA bus
 - features of, 4-12
 - location of, 4-7
 - problems at power-up, 5-25
 - troubleshooting, 5-25
 - troubleshooting tips, 5-27

EISA configuration procedure, 4–19
EISA Configuration Utility
 See ECU
EISA I/O boards
 location of, 1–12
EISA/ISA boards
 configuring, 4–21
EISA/ISA configuration procedure, 4–21
Enclosure, 1–6
Environment variables
 resetting, 3–14
Errors
 commands to report, 5–17
Ethernet
 external loopback, 5–19
Extended I/O module, 4–9
 location of, 4–7

F

Fail-safe loader, 5–31
 activating, 5–31
 power-up, 5–31
Failover, 3–12
Fast SCSI-2 adapter, 4–25
Fixed-media
 storage problems, 5–21
Floppy drive
 operation of, 3–1
Front bezel
 installation of, 2–24
 removal of, 2–24
FRUs
 commands to report errors, 5–17

H

Halt button
 invoking console mode with, 3–3
 invoking operating system mode with,
 3–3
 location of, 1–9
Hangs
 using Reset button to recover from, 3–4

I

I/O boards
 EISA, location of, 1–12
 PCI, location of, 1–12
I/O bus, EISA features, 4–12
I/O module, 4–11
init -driver command, 5–32
Installation
 front bezel, 2–24
Internal SCSI bus, 4–25
Interrupt lines
 and EISA, 5–27
IRQs
 and EISA, 5–27
ISA boards, identifying, 4–14
ISA bus
 defined, 4–13
ISA/EISA boards
 configuring, 4–21
ISA/EISA configuration procedure, 4–21

L

Loopback tests
 COM2 and parallel ports, 5–19

M

Managing
 ARC boot selections, 3–1
Mass storage
 actions before operating devices, 3–25
 described, 4–25
 problems, troubleshooting, 5–21, 5–23
 supported devices, 3–25
Mass storage devices
 actions before operating, 3–25
 mounting, 3–25
 supported, 3–25
Memory module
 location of, 4–7
 variations of, 4–9

Modem, connecting, 2–30

Modules

CPU, 4–8

Extended I/O, 4–9

N

Networks

connecting to, 2–28

Ethernet, 2–28

nvrAm file, 5–32

O

Operating system

boot failures, reporting, 5–30

preboot tasks, 3–14

Operating system problems

troubleshooting, 5–30

Operating system, booting, 3–18

Operating systems

switching, 3–17

Operation

compact disc drive, 3–1

DAT tape drive, 3–1

floppy drive, 3–1

QIC tape drive, 3–1

storage devices, 3–1

Operator control panel

controls

location of, 1–8

controls on, 1–9

DC On/Off button, 3–2

DC On/Off light, 3–2

display, interpreting, 5–12

Halt button, 3–3

Halt light, 3–3

location of, 1–8

power-up/diagnostic display, 3–2

Reset button, 3–4

Options

adding, 4–2

from non-Digital vendors, 4–2

installing, 4–2

supported, 4–4

P

PCI, 1–6

PCI bus

defined, 4–23

location of, 4–7

troubleshooting, 5–28

PCI I/O boards

location of, 1–12

Peripheral devices, connecting, 2–30

Phone numbers

customer support, 5–7

Power problems

troubleshooting, 5–10

Power supplies

location of, 1–8

Power supply configurations, 4–30

Power-down procedure

turning off dc power, 3–20

Power-up display

interpreting, 5–12

Power-up sequence

mass-storage failures, 5–21

PCI failures, 5–28

Power-up/diagnostic display, 3–8

Printer, connecting, 2–30

Problem reporting, 5–6

Problems

See Troubleshooting

determining type, 5–5

identifying, 5–1, 5–4

Q

QIC tape drive

operating, 3–38

operation of, 3–1

R

RAID subsystem

guidelines, 4–10

problems with, 5–24

- Reboot procedure, 3–18
- Removable-media
 - storage problems, 5–23
- Removable-media compartments
 - configuration rules, 4–26
- Removable-media devices
 - SCSI support for, 4–25
- Reset button
 - for recovering from hangs, 3–4
 - location of, 1–9

S

- SCSI bus
 - expansion of, 2–32
 - internal, 4–25
- Self-test status lights
 - location of, 1–9
- Serial ports, 3–8, 4–32
- show fru command (SRM), 5–17
- SMP configuration
 - CPU modules, 4–8
- SRM firmware
 - using the, 3–1
- Standard I/O module, 4–11
- Startup procedure
 - preboot tasks, 3–14
- Storage devices
 - mounting, 3–25
 - operating, 3–25
 - operation of, 3–1
- Supported options, 4–4
- SWXCR controller
 - guidelines, 4–10
- System
 - before installing the, 2–2
 - configuration, verifying, 4–5
 - expansion of SCSI, 2–32
 - turning off, 3–20
 - turning on, 3–5
- System bus, location of, 4–7
- System components
 - front, 1–8

- System Configuration Diskette, 4–15
- System configuration, verifying
 - for DEC OSF/1, 4–5
 - for OpenVMS, 4–5
 - for Windows NT, 4–5
- System operation
 - boot, 3–18
 - reboot, 3–18
- System software
 - booting, 3–18
- System startup screen, 3–8
- SYSTEMCFG volume label, 4–15

T

- Tape drive
 - See QIC tape drive; DAT tape drive
- Tape drives
 - mounting, 3–25
- Terminal
 - connecting to, 2–26
 - console, 2–26
- test command, 5–19
- Troubleshooting, 5–1
 - boot problems, 5–29
 - considerations before beginning, 5–2
 - console, 5–11
 - console mode problems, 5–16
 - EISA problems, 5–25
 - errors reported by operating system, 5–30
 - for self-maintenance customers, 5–2
 - interpreting the operator control panel
 - power-up display, 5–12
 - mass-storage problems, 5–21
 - operating system problems, 5–30
 - PCI problems, 5–28
 - power problems, 5–10
 - problem reference, 5–5
 - problem worksheet, 5–9
 - problems getting to console mode, 5–11
 - problems reported by the console, 5–16
 - RAID device problems, 5–24
 - reporting problems, 5–6
 - task overview, 5–4

Troubleshooting (cont'd)
test command, 5-2

U

Upgrades
 planning, 4-2
Using firmware
 ARC, 3-1
 SRM, 3-1

How to Order Additional Documentation

Technical Support

If you need help deciding which documentation best meets your needs, call 800-DIGITAL (800-344-4825) and press 2 for technical assistance.

Electronic Orders

If you wish to place an order through your account at the Electronic Store, dial 800-234-1998, using a modem set to 2400- or 9600-baud. You must be using a VT terminal or terminal emulator set at 8 bits, no parity. If you need assistance using the Electronic Store, call 800-DIGITAL (800-344-4825) and ask for an Electronic Store specialist.

Telephone and Direct Mail Orders

From	Call	Write
U.S.A.	DECdirect Phone: 800-DIGITAL (800-344-4825) Fax: (603) 884-5597	Digital Equipment Corporation P.O. Box CS2008 Nashua, NH 03061
Puerto Rico	Phone: (809) 781-0505 Fax: (809) 749-8377	Digital Equipment Caribbean, Inc. 3 Digital Plaza, 1st Street Suite 200 Metro Office Park San Juan, Puerto Rico 00920
Canada	Phone: 800-267-6215 Fax: (613) 592-1946	Digital Equipment of Canada Ltd. 100 Herzberg Road Kanata, Ontario, Canada K2K 2A6 Attn: DECdirect Sales
International	—————	Local Digital subsidiary or approved distributor
Internal Orders ¹ (for software documentation)	DTN: 264-3030 (603) 884-3030 Fax: (603) 884-3960	U.S. Software Supply Business Digital Equipment Corporation 10 Cotton Road Nashua, NH 03063-1260
Internal Orders (for hardware documentation)	DTN: 264-3030 (603) 884-3030 Fax: (603) 884-3960	U.S. Software Supply Business Digital Equipment Corporation 10 Cotton Road Nashua, NH 03063-1260

¹Call to request an Internal Software Order Form (EN-01740-07).

Reader's Comments

AlphaServer 2100 CAB
Installation/Owner's Guide

EK-ALCAB-OG. B01

Your comments and suggestions help us improve the quality of our publications.

Thank you for your assistance.

I rate this manual's:	Excellent	Good	Fair	Poor
Accuracy (product works as manual says)	<input type="checkbox"/>	<input type="checkbox"/>	<input type="checkbox"/>	<input type="checkbox"/>
Completeness (enough information)	<input type="checkbox"/>	<input type="checkbox"/>	<input type="checkbox"/>	<input type="checkbox"/>
Clarity (easy to understand)	<input type="checkbox"/>	<input type="checkbox"/>	<input type="checkbox"/>	<input type="checkbox"/>
Organization (structure of subject matter)	<input type="checkbox"/>	<input type="checkbox"/>	<input type="checkbox"/>	<input type="checkbox"/>
Figures (useful)	<input type="checkbox"/>	<input type="checkbox"/>	<input type="checkbox"/>	<input type="checkbox"/>
Examples (useful)	<input type="checkbox"/>	<input type="checkbox"/>	<input type="checkbox"/>	<input type="checkbox"/>
Index (ability to find topic)	<input type="checkbox"/>	<input type="checkbox"/>	<input type="checkbox"/>	<input type="checkbox"/>
Page layout (easy to find information)	<input type="checkbox"/>	<input type="checkbox"/>	<input type="checkbox"/>	<input type="checkbox"/>

I would like to see more/less _____

What I like best about this manual is _____

What I like least about this manual is _____

I found the following errors in this manual:

Page	Description
_____	_____
_____	_____
_____	_____

Additional comments or suggestions to improve this manual:

For software manuals, please indicate which version of the software you are using: _____

Name/Title _____ Dept. _____

Company _____ Date _____

Mailing Address _____

Phone _____

Do Not Tear - Fold Here and Tape

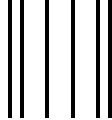

No Postage
Necessary
If Mailed
in the
United States

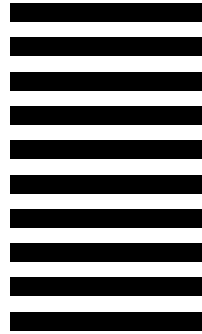

BUSINESS REPLY MAIL
FIRST CLASS PERMIT NO. 33 MAYNARD MASS.

POSTAGE WILL BE PAID BY ADDRESSEE

DIGITAL EQUIPMENT CORPORATION
Shared Engineering Services
DIGITAL DRIVE MK01-2/E12
PO BOX 9501
MERRIMACK, NH 03054-9982



Do Not Tear - Fold Here