

"THE MATERIAL HEREIN IS FOR INFORMATION PURPOSES ONLY AND IS SUBJECT TO CHANGE WITHOUT NOTICE. DIGITAL EQUIPMENT CORPORATION ASSUMES NO RESPONSIBILITY FOR ANY ERRORS WHICH MAY APPEAR HEREIN."

FIELD MAINTENANCE PRINT SET

"THIS DRAWING AND SPECIFICATIONS, HEREIN, ARE THE PROPERTY OF DIGITAL EQUIPMENT CORPORATION AND SHALL NOT BE REPRODUCED OR COPIED OR USED IN WHOLE OR IN PART AS THE BASIS FOR THE MANUFACTURE OR SALE OF ITEMS WITHOUT WRITTEN PERMISSION. COPYRIGHT © 1976 . DIGITAL EQUIPMENT CORPORATION."

TABLE OF CONTENTS

B-TC-1134A-0-1	FIELD MAINTENANCE PRINT SET (1134A)
E-UA-1134A-0-0	UNIT ASSEMBLY (1134A)
C-PL-1134A-0-0	PARTS LIST (1134A)
B-DD-1134A-0-0	DRAWING DIRECTORY (1134A)
MP00192	PRINT SET KD11-EA (COMPLETE SET)
D-CS-M9301-0-1	UNIBUS TERMINATOR/BOOT STRAP
D-CS-M9302-0-1	UNIBUS TERMINATOR
MP00017	PRINT SET KY11-LA (COMPLETE SET)
MP00015	PRINT SET KY11-LB (COMPLETE SET)
MP00106	PRINT SET DL11-W (COMPLETE SET)
B-CS-M7850-0-1	PARITY MODULE
B-CS-G727-0-1	GRANT CONTINUITY
MP00021	PRINT SET MS11-E (COMPLETE SET)
MP00032	PRINT SET MM11-D (COMPLETE SET)
MP000317	PRINT SET MM11-YP (COMPLETE SET)
B-DD-DD11-P	DRAWING DIRECTORY DD11-P (COMPLETE SET)
MP00018	PRINT SET BALL-L (COMPLETE SET)
E-UA-BALL-K-0	UNIT ASSY BALL-K
A-PL-BALL-K-0	UNIT ASSY BALL-K (PL)
B-DD-BALL-K	DRAWING DIRECTORY BALL-K
MP00270	PRINT SET 1134A P.S. (COMPLETE SET)
C-IA-7011413-0-0	EXTERNAL BOOT CABLE
C-IA-7011411-0-0	CONSOLE CABLE
D-IA-7011992-0-0	CONSOLE POWER HARNESS
A-PL-1134A-0-4	SHIPPING LIST (1134A)
D-CS-M9312-0-1	UNIBUS TERM. BOOT STRAP

		115V	230V
		UNIT VARIATIONS COVERED BY THIS PRINT SET	
5.25 Box		1134A-DC	1134A-DD
		1134A-HC	1134A-HD
		1134A-LC	1134A-LD
		1134A-MC	1134A-MD
		1134A-JC	1134A-JD
10.5 Box		1134A-DH	1134A-DJ
		1134A-HH	1134A-HJ
		1134A-LH	1134A-LJ
		1134A-MH	1134A-MJ
		1134A-DE	1134A-DF
		1134A-HE	1134A-HF
		1134A-LE	1134A-LF
		1134A-ME	1134A-MF
		1134A-JH	1134A-JJ
		1134A-JE	1134A-JF

**1134A
Field Maintenance
Print Set**

**Digital Equipment
Corporation**

PRINT SET ORDER NO.
MP00190

DRB EN-01124 16N675-1271

REVISIONS			USED ON OPTION/MODEL		DRN.	DATE	digital			
DATE	CHG. NO.	REV.			D. HEALY	NOV 76				
12-77	1134A-7	A			CHK'D	DATE				
2-78	1134A-8	B			D. HEALY	NOV 76	SIZE B			
					PROJ. ENG.	DATE				
					DAVE MOBERLY	13JAN77	NUMBER 1134A-0-1			
					FIELD SERV.	DATE				
							DIST.			
			SHEET I OF I		ROY M EVANS	13JAN77				

THIS DRAWING AND SPECIFICATIONS HEREIN ARE THE PROPERTY OF SPATIAL EQUIPMENT CORPORATION AND SHALL NOT BE REPRODUCED OR COPIED OR USED IN WHOLE OR IN PART AS THE BASIS FOR THE MANUFACTURE OF SUCH EQUIPMENT WITHOUT WRITTEN PERMISSION.
 COPYRIGHT © 1977, SPATIAL EQUIPMENT CORPORATION

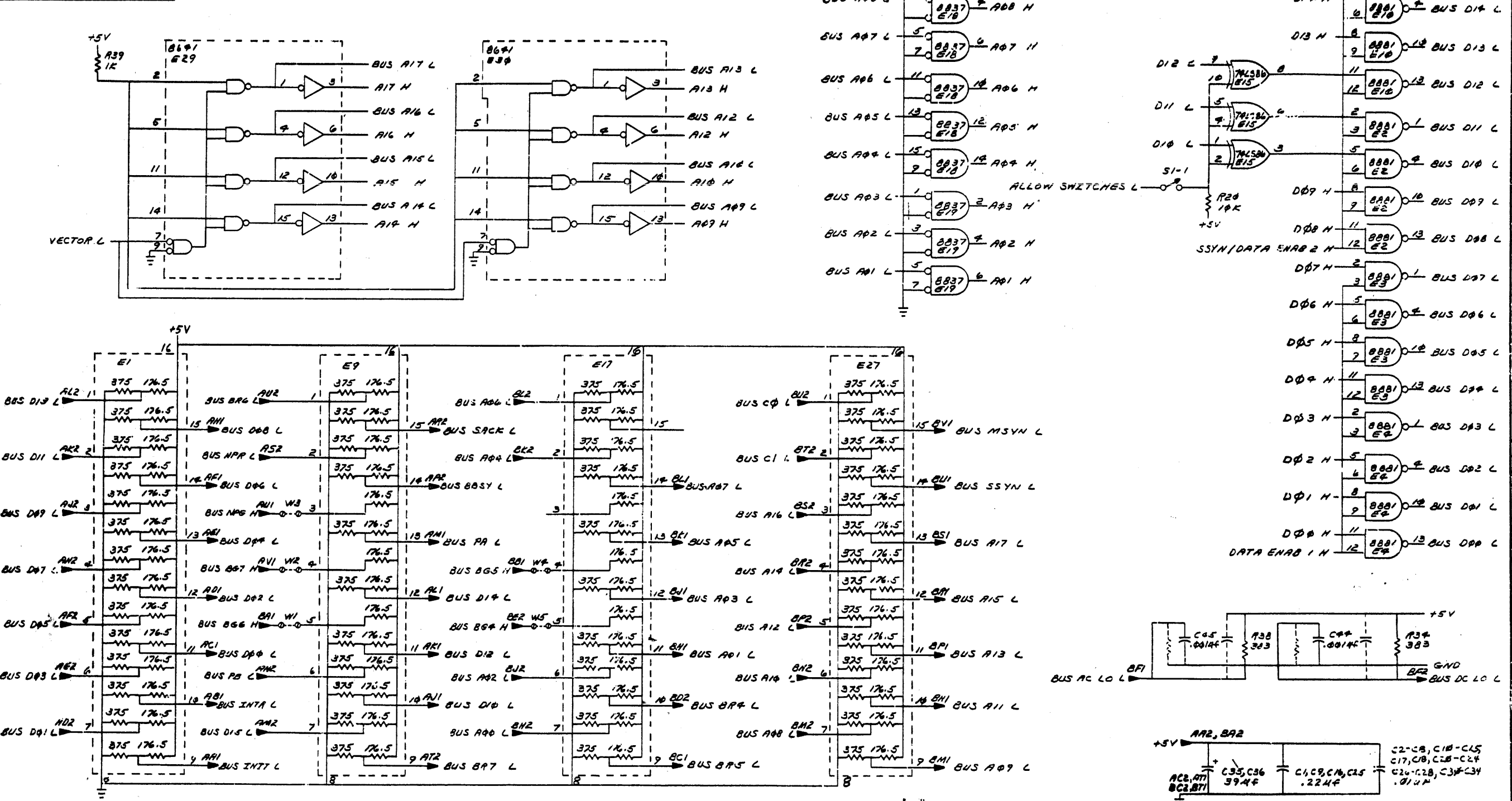

REV.	CHG.	NO.	DATE	BY
1	1	0001	12-28-77	W. J. B.
2	1	0002	12-28-77	W. J. B.

(BUS TERMINATOR, DRIVERS AND RECEIVERS)

DRN. <i>W. J. B.</i>	12-28-77	FIRST USED ON	
CHK'D <i>W. J. B.</i>	12-28-77		
ENG. <i>W. J. B.</i>	12-28-77	TITLE	BOOTSTRAP TERMINATOR
PROJ. ENG. <i>W. J. B.</i>	1-28-78		
PROD. <i>W. J. B.</i>	11-28-78		
NEXT HIGHER ASSY.			
SCALE		SIZE CODE	NUMBER
SHEET 1 OF 4		D CS M9312-0-1	B

"THIS DRAWING AND SPECIFICATIONS, HEREIN, ARE THE PROPERTY OF DIGITAL EQUIPMENT CORPORATION AND SHALL NOT BE REPRODUCED OR COPIED OR USED IN WHOLE OR IN PART AS THE BASIS FOR THE MANUFACTURE OR SALE OF ITEMS WITHOUT WRITTEN PERMISSION. COPYRIGHT © 1977 DIGITAL EQUIPMENT CORPORATION"

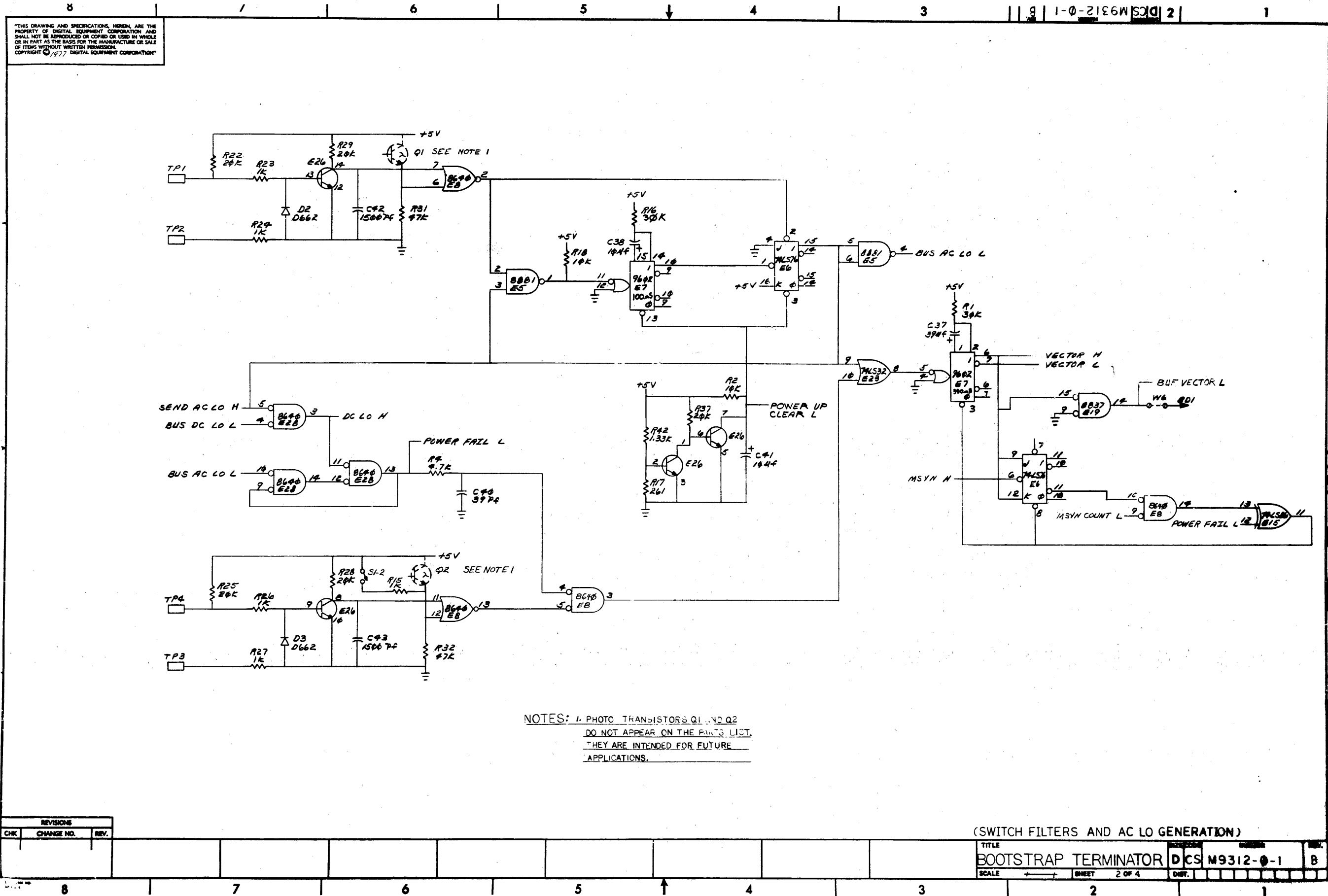

NOTES: 1. PHOTO TRANSISTORS Q1 AND Q2 DO NOT APPEAR ON THE PARTS LIST. THEY ARE INTENDED FOR FUTURE APPLICATIONS.

REVISIONS		
CHK	CHANGE NO.	REV.

(SWITCH FILTERS AND AC LO GENERATION)

TITLE	BOOTSTRAP TERMINATOR	D E S M 9312-0-1	B
SCALE	← →	SHEET 2 OF 4	DWT.

THIS DRAWING AND SPECIFICATIONS HEREIN ARE THE PROPERTY OF DIGITAL EQUIPMENT CORPORATION AND SHALL NOT BE REPRODUCED OR COPIED OR USED IN WHOLE OR IN PART AS THE BASIS FOR THE MANUFACTURE OR SALE OF ITEMS WITHOUT WRITTEN PERMISSION OF DIGITAL EQUIPMENT CORPORATION

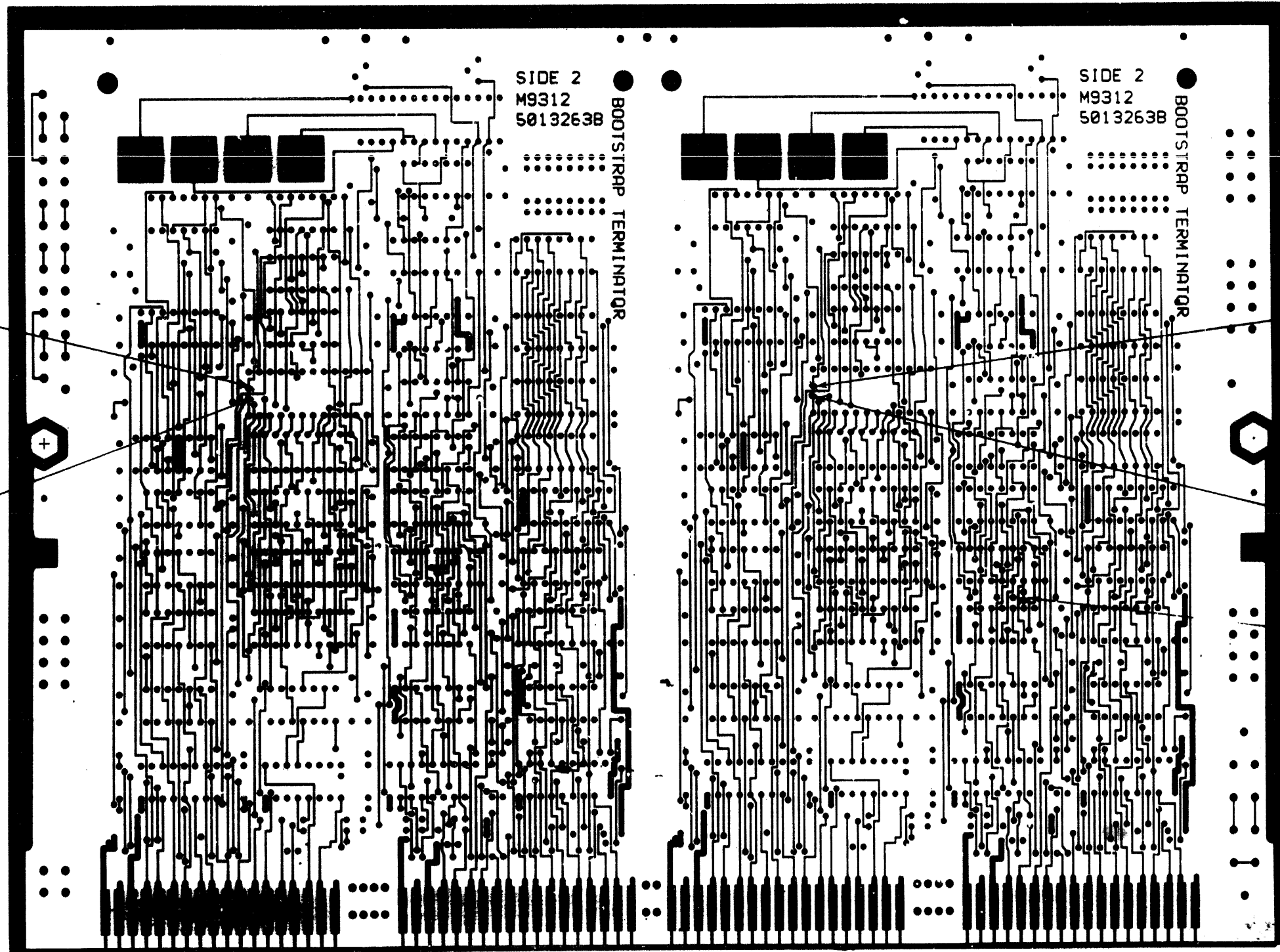

REVISIONS		
HK	CHANGE NO.	REV.

TITLE	SIZE CODE	NUMBER	REV.
BOOTSTRAP TERMINATOR	D UA	M9312-0-0	B
SCALE 2-1	SHEET 3 OF 4	DIST.	

THE DESIGN AND SPECIFICATION HEREIN ARE THE PROPERTY OF CONTROL ELECTRONICS CORPORATION AND SHALL BE KEPT CONFIDENTIAL UNLESS SO ORDERED BY WRITTEN OR PRINTED AS THE APPLICABLE OR SALE OF THIS DRAWING TO OTHER PERSONS. CONTROL ELECTRONICS CORPORATION

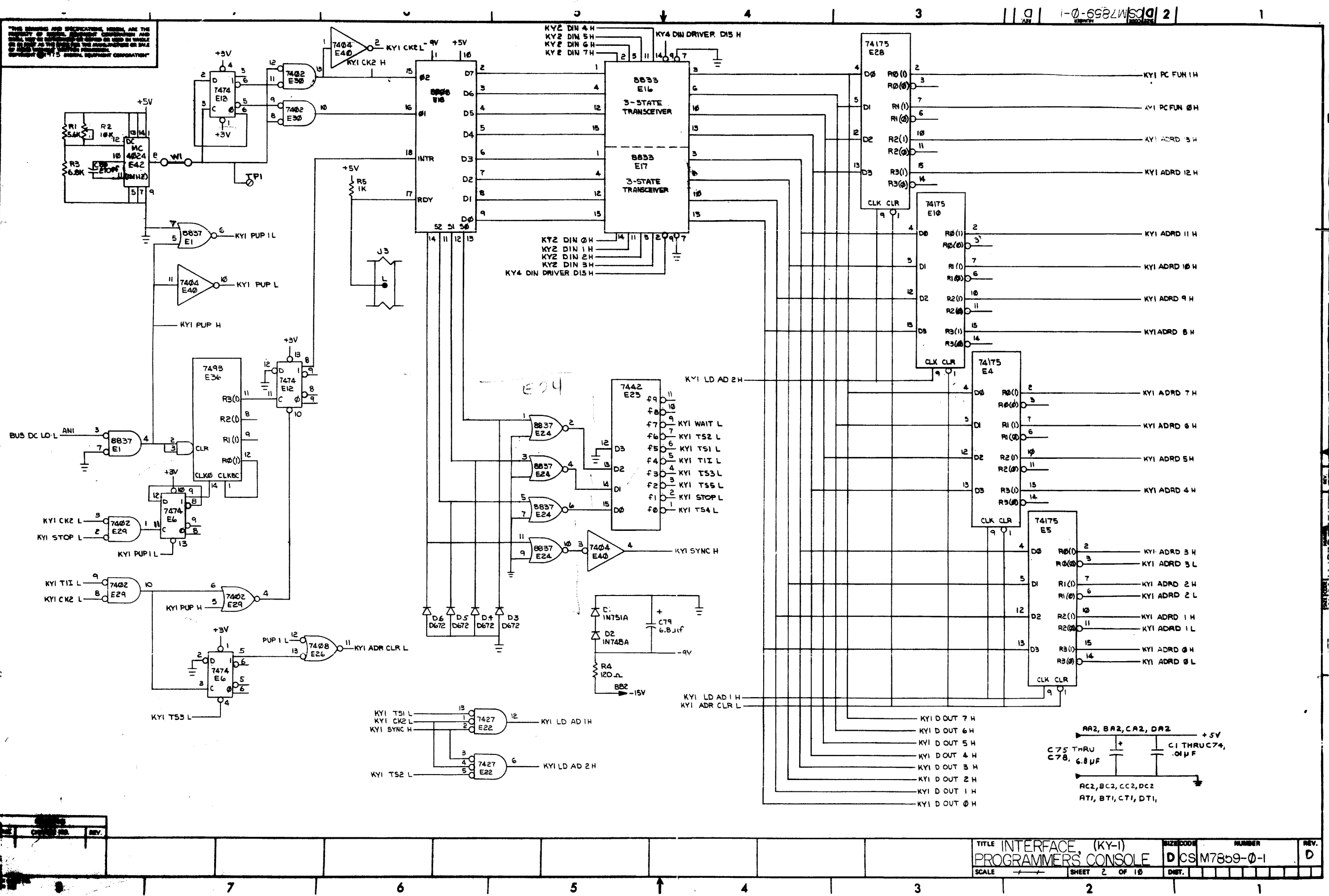

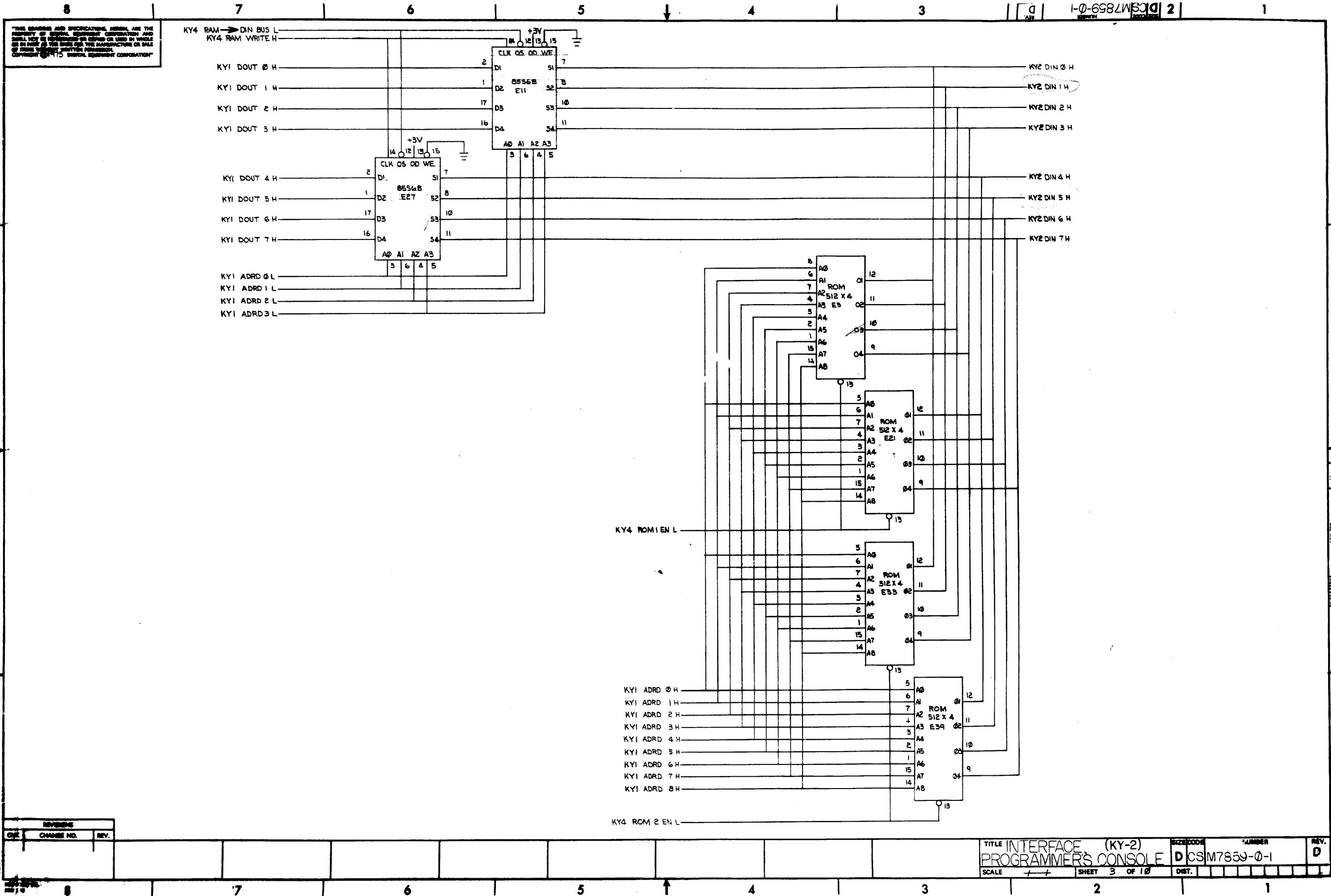

D
C
B
A

D
C
B
A

THIS DRAWING AND SPECIFICATIONS HEREIN ARE THE PROPERTY OF SPERRY GYROSCOPE CORPORATION AND SHALL NOT BE REPRODUCED OR COPIED OR USED IN WHOLE OR IN PART AS THE BASIS FOR THE MANUFACTURE OR SALE OF ITEMS UNLESS A WRITTEN PERMISSION IS OBTAINED FROM SPERRY GYROSCOPE CORPORATION.

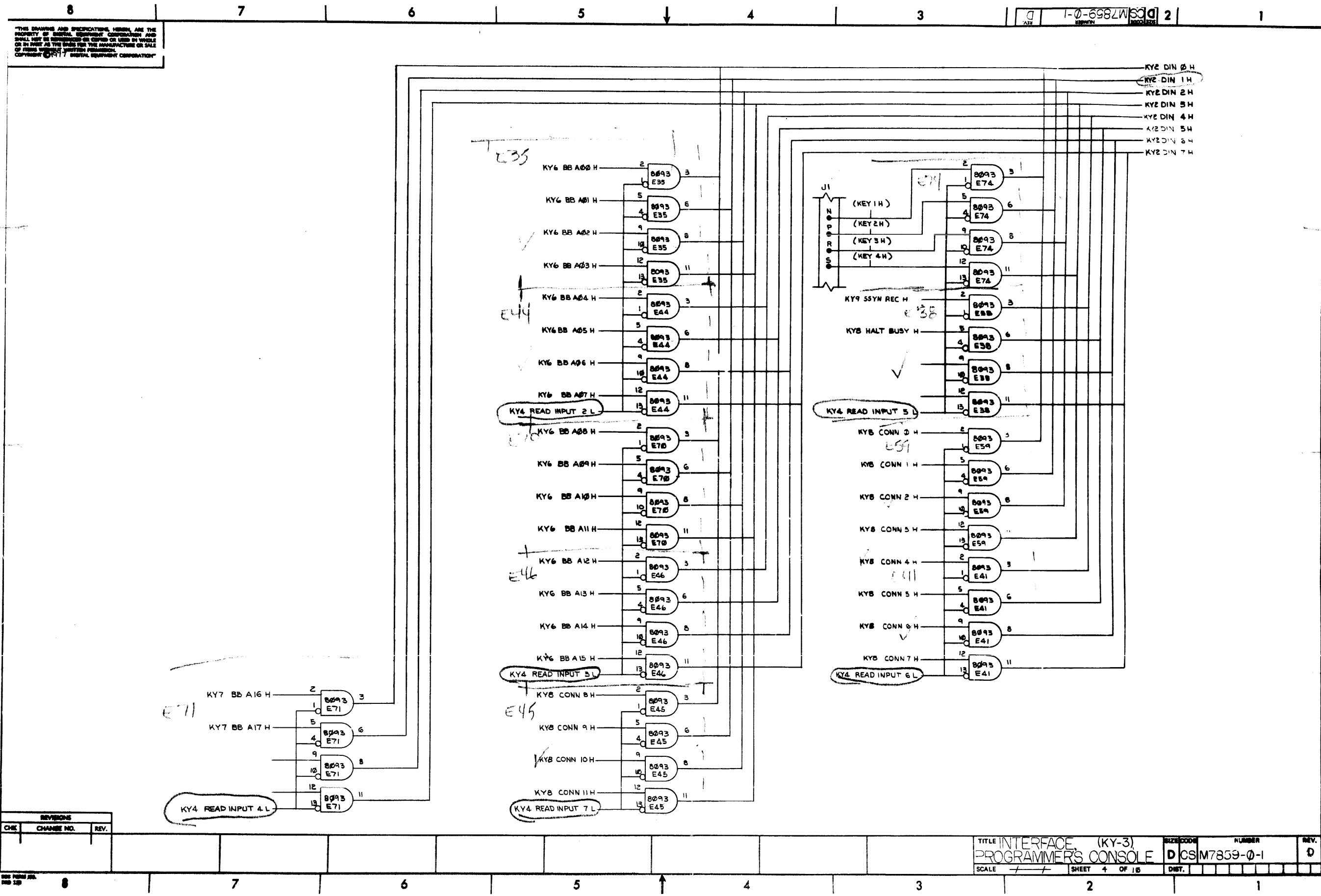

REVISIONS		
CHK	CHANGE NO.	REV.

THE DRAWING AND SPECIFICATIONS HEREIN ARE THE PROPERTY OF SERIAL EQUIPMENT CORPORATION AND SHALL NOT BE REPRODUCED OR USED IN WHOLE OR IN PART AS THE BASIS FOR THE MANUFACTURE OR SALE OF ITEMS WITHOUT WRITTEN PERMISSION. COPYRIGHT © 1975 SERIAL EQUIPMENT CORPORATION

- KY7 BB A17 H 1
- KY7 BB A16 H 2
- KY6 BB A15 H 3
- KY6 BB A14 H 4
- KY6 BB A13 H 5
- KY6 BB A12 H 6
- KY6 BB A11 H 7
- KY6 BB A10 H 8
- KY6 BB A09 H 9
- KY6 BB A08 H 10
- KY6 BB A07 H 11
- KY6 BB A06 H 12
- KY6 BB A05 H 13
- KY6 BB A04 H 14
- KY6 BB A03 H 15

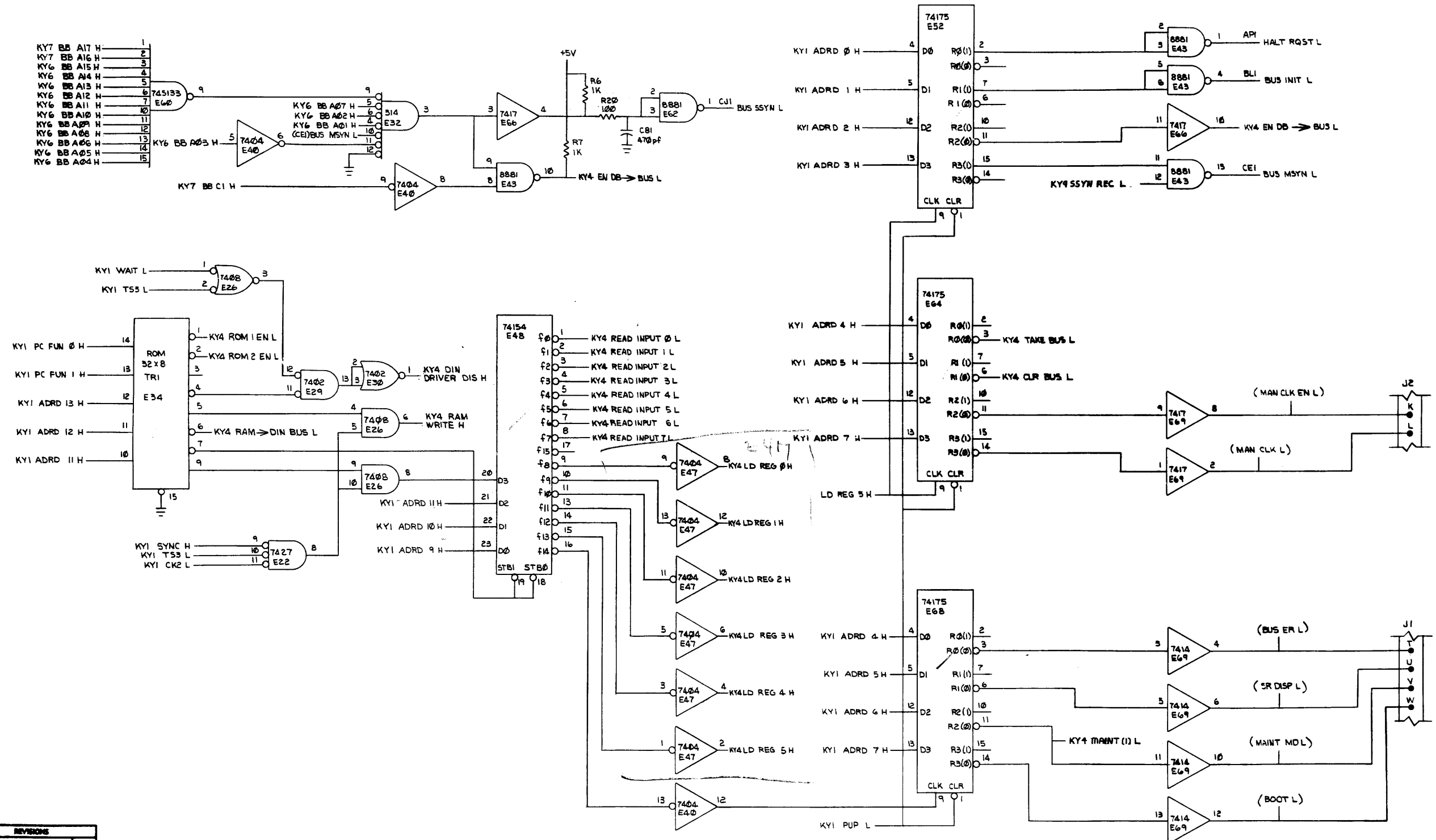

REVISIONS		
CHK	CHANGE NO.	REV.

ALL LOGIC AND MECHANICAL SYMBOLS ARE THE PROPERTY OF THE DESIGNER AND SHOULD NOT BE REPRODUCED OR TRANSMITTED IN ANY FORM OR BY ANY MEANS, ELECTRONIC, MECHANICAL, PHOTOCOPYING, RECORDING, OR BY ANY INFORMATION STORAGE AND RETRIEVAL SYSTEM.

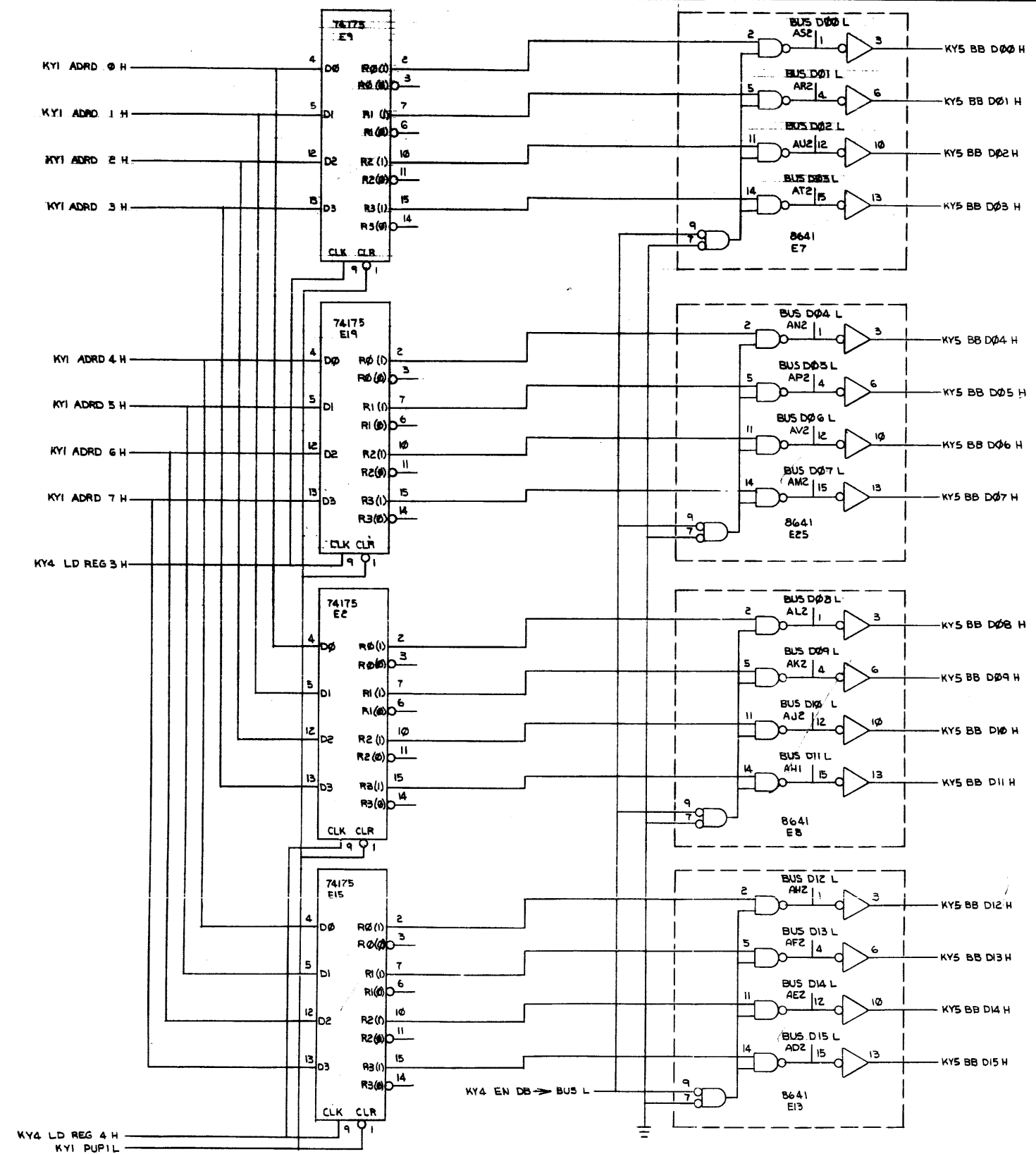

REVISIONS		
CHK	CHANGE NO.	REV.

KY4 LD REG 4 H
KY1 PUPIL

THE DRAWING AND SPECIFICATIONS HEREIN ARE THE PROPERTY OF DIGITAL EQUIPMENT CORPORATION AND SHALL NOT BE REPRODUCED OR COPIED OR USED IN WHOLE OR IN PART AS THE BASIS FOR THE MANUFACTURE OR SALE OF ITEMS WITHOUT WRITTEN PERMISSION. COPYRIGHT © 1975 DIGITAL EQUIPMENT CORPORATION

1-0-8982WSD 2

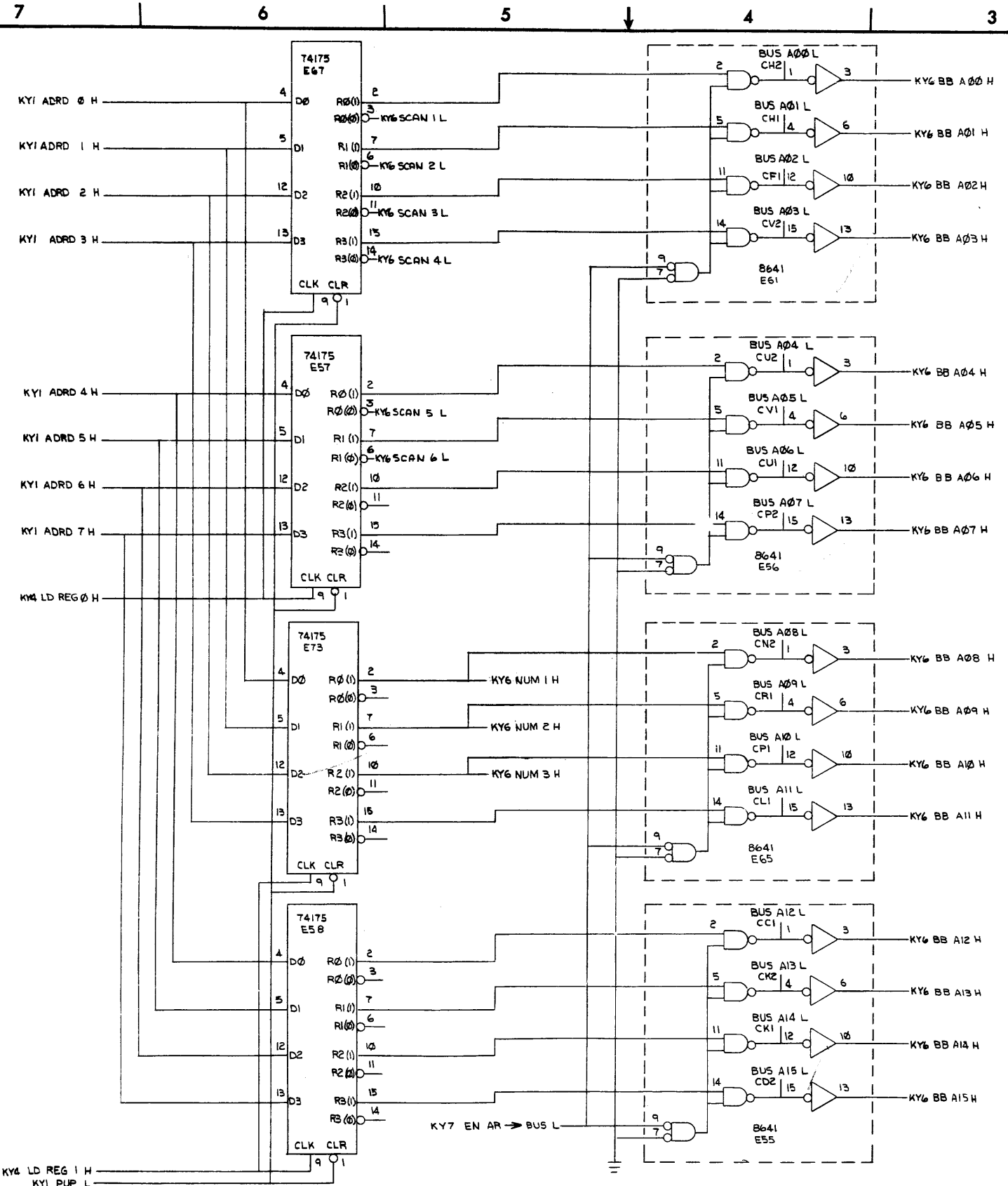

REVISIONS		
CHK	CHANGE NO.	REV.

KY4 LD REG 1 H
KY1 PUP L

TITLE INTERFACE, (KY-6)
PROGRAMMER'S CONSOLE
SCALE 1/8" = 1"

SIZE CODE NUMBER
D CSM7859-0-1

SHEET 7 OF 10

"THIS DRAWING AND SPECIFICATIONS HEREIN ARE THE PROPERTY OF SPITAL EQUIPMENT CORPORATION AND SHALL NOT BE REPRODUCED OR COPIED OR USED IN WHOLE OR IN PART AS THE BASIS FOR THE MANUFACTURE OR SALE OF ITEMS WITHOUT WRITTEN PERMISSION. COPYRIGHT © SPITAL EQUIPMENT CORPORATION"

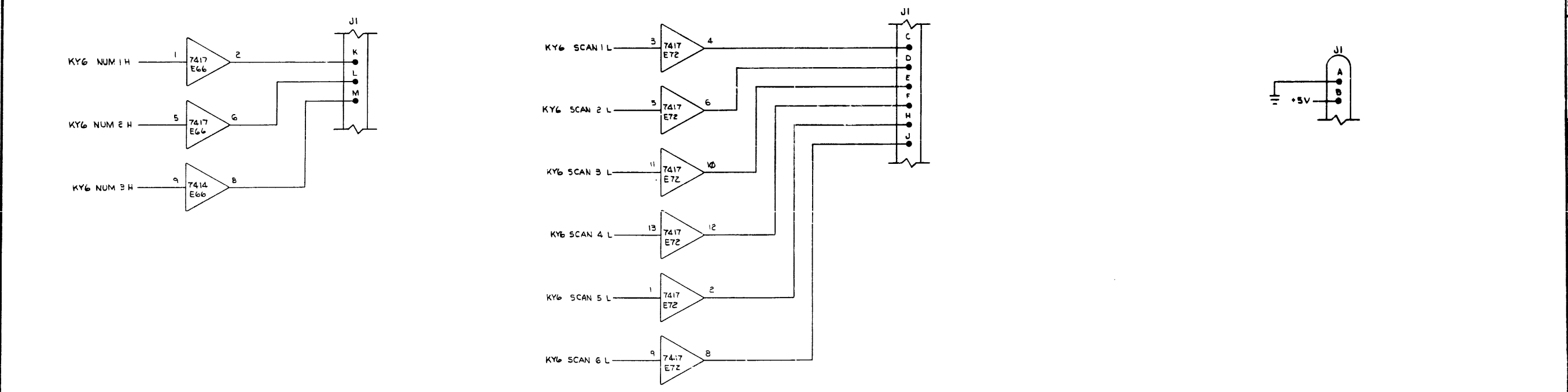
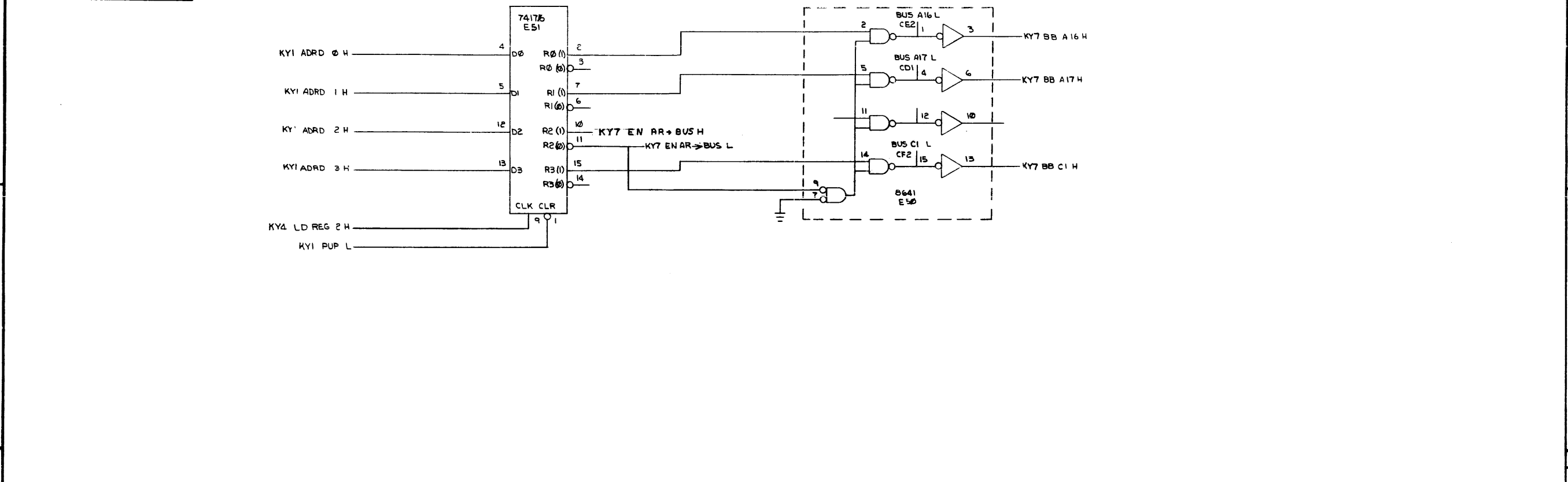

REVISIONS		
CHK	CHANGE NO.	REV.

THIS DRAWING AND SPECIFICATION HEREIN ARE THE PROPERTY OF DIGITAL EQUIPMENT CORPORATION AND SHALL NOT BE REPRODUCED OR COPIED OR USED IN WHOLE OR IN PART AS THE BASIS FOR THE MANUFACTURE OR SALE OF PRODUCTS WITHOUT WRITTEN PERMISSION. COPYRIGHT © 1977 DIGITAL EQUIPMENT CORPORATION

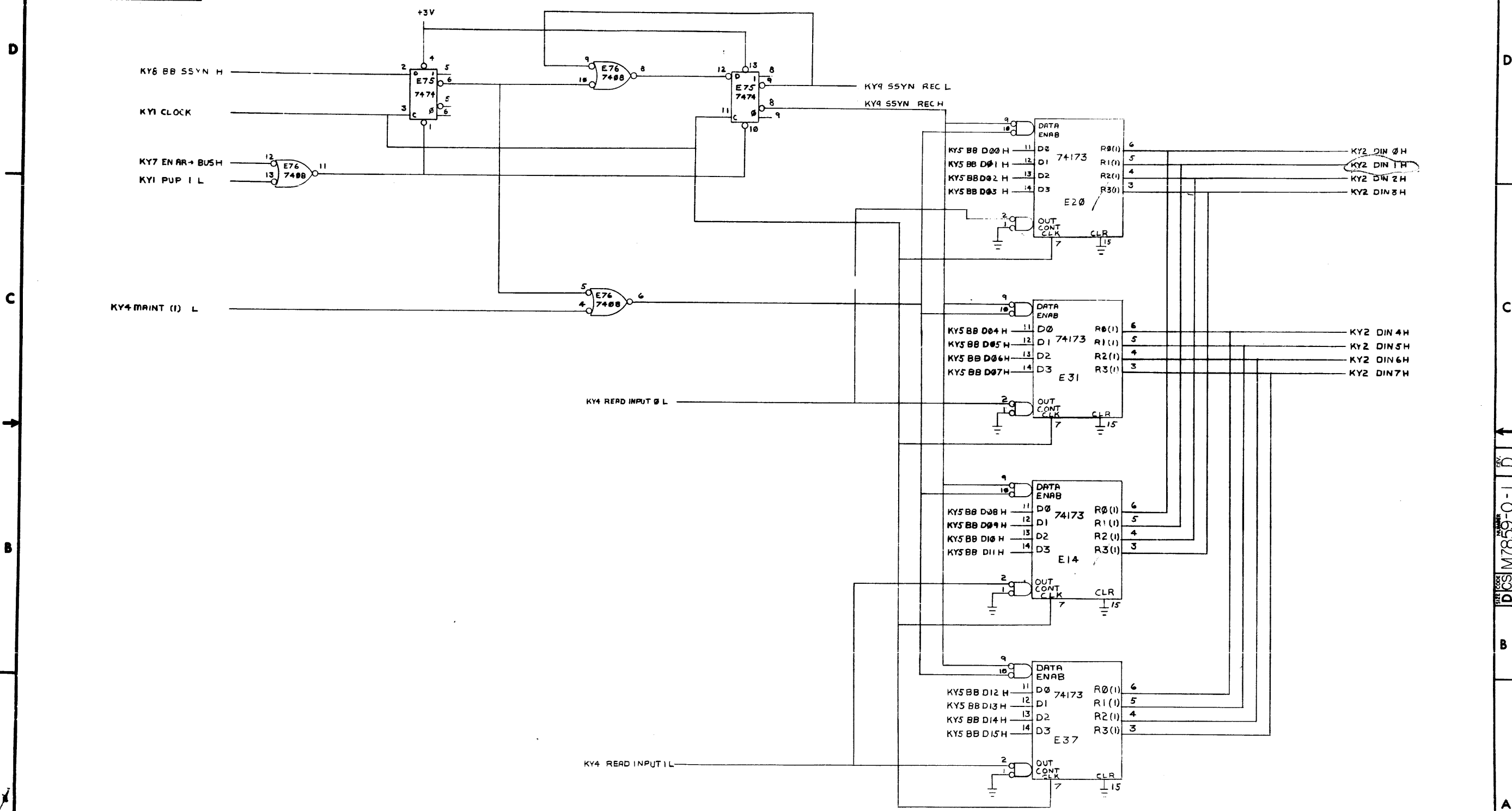

REV.	CHANGE NO.	REV.

COMPONENT SIDE VIEW

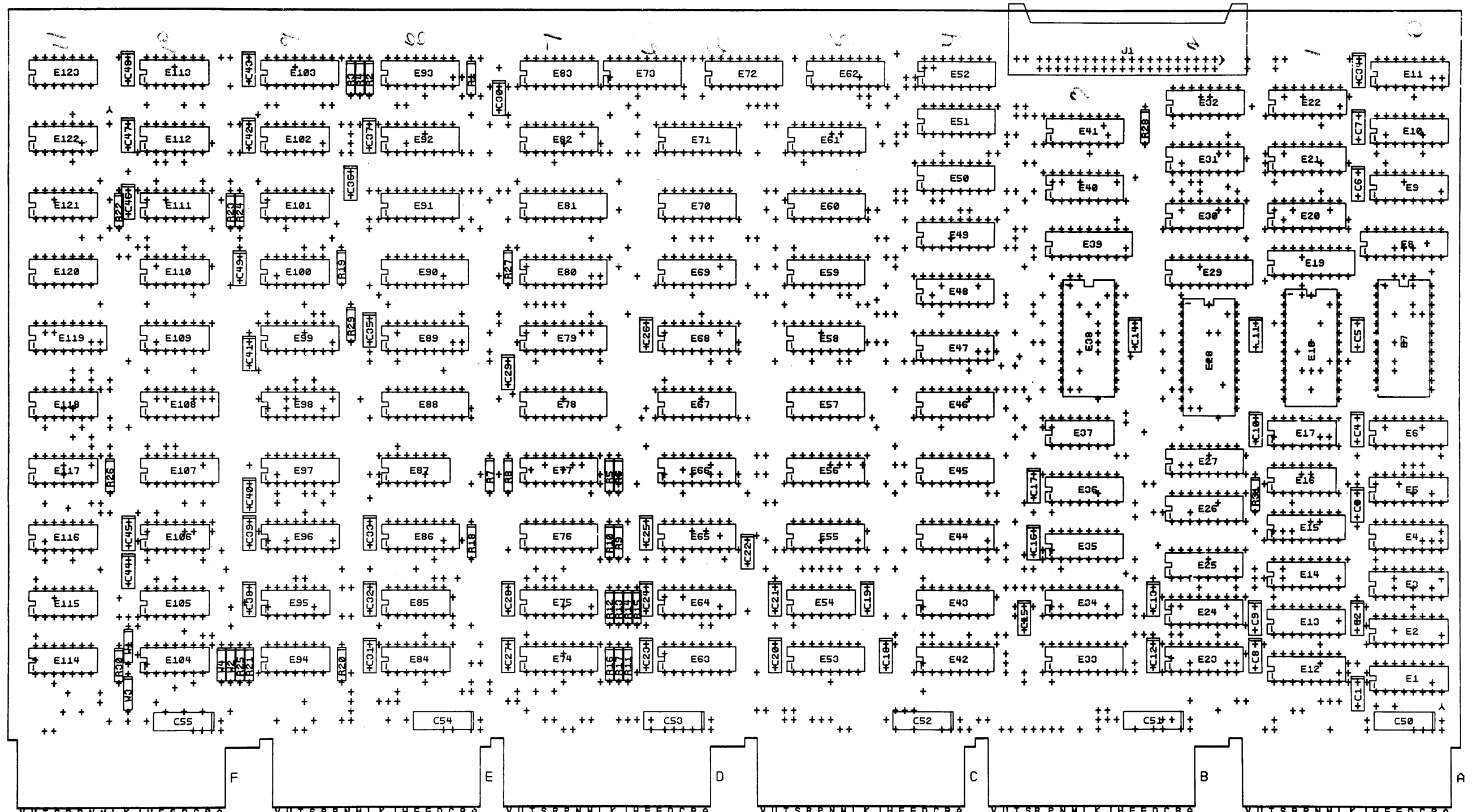

NOTES:

CHANGE NO	REV	DATE	BY	APP
1	1	7-20-72	M. SULLIVAN	
2	1	7-20-72	M. SULLIVAN	
3	1	7-20-72	M. SULLIVAN	
4	1	7-20-72	M. SULLIVAN	
5	1	7-20-72	M. SULLIVAN	
6	1	7-20-72	M. SULLIVAN	
7	1	7-20-72	M. SULLIVAN	
8	1	7-20-72	M. SULLIVAN	
9	1	7-20-72	M. SULLIVAN	
10	1	7-20-72	M. SULLIVAN	

ETCH REV. B-PI
PC DESIGN DATA BRSE REV.

SIGNATURES		DATE
DRN. D. BILODEAU		9-8-76
CHK'D. <i>[Signature]</i>		9-1-72
ENG. <i>[Signature]</i>		7-17-72
PROD. <i>[Signature]</i>		7-17-72
SCALE 2/1		
SHT. 1 OF 3		
NEXT HIGHER ASSY. B DD M8265-0-C		

digital	
TITLE KD11-EA DATA PATH	
SIZE CODE	NUMBER
D UA	M8265-0-C
REV	B

THIS DRAWING AND SPECIFICATIONS HEREIN ARE THE PROPERTY OF DIGITAL EQUIPMENT CORPORATION AND SHALL NOT BE REPRODUCED OR COPIED OR USED IN WHOLE OR IN PART AS THE BASIS FOR THE MANUFACTURE OR SALE OF ANY PRODUCT WITHOUT THE WRITTEN PERMISSION OF DIGITAL EQUIPMENT CORPORATION.

LAYER 1

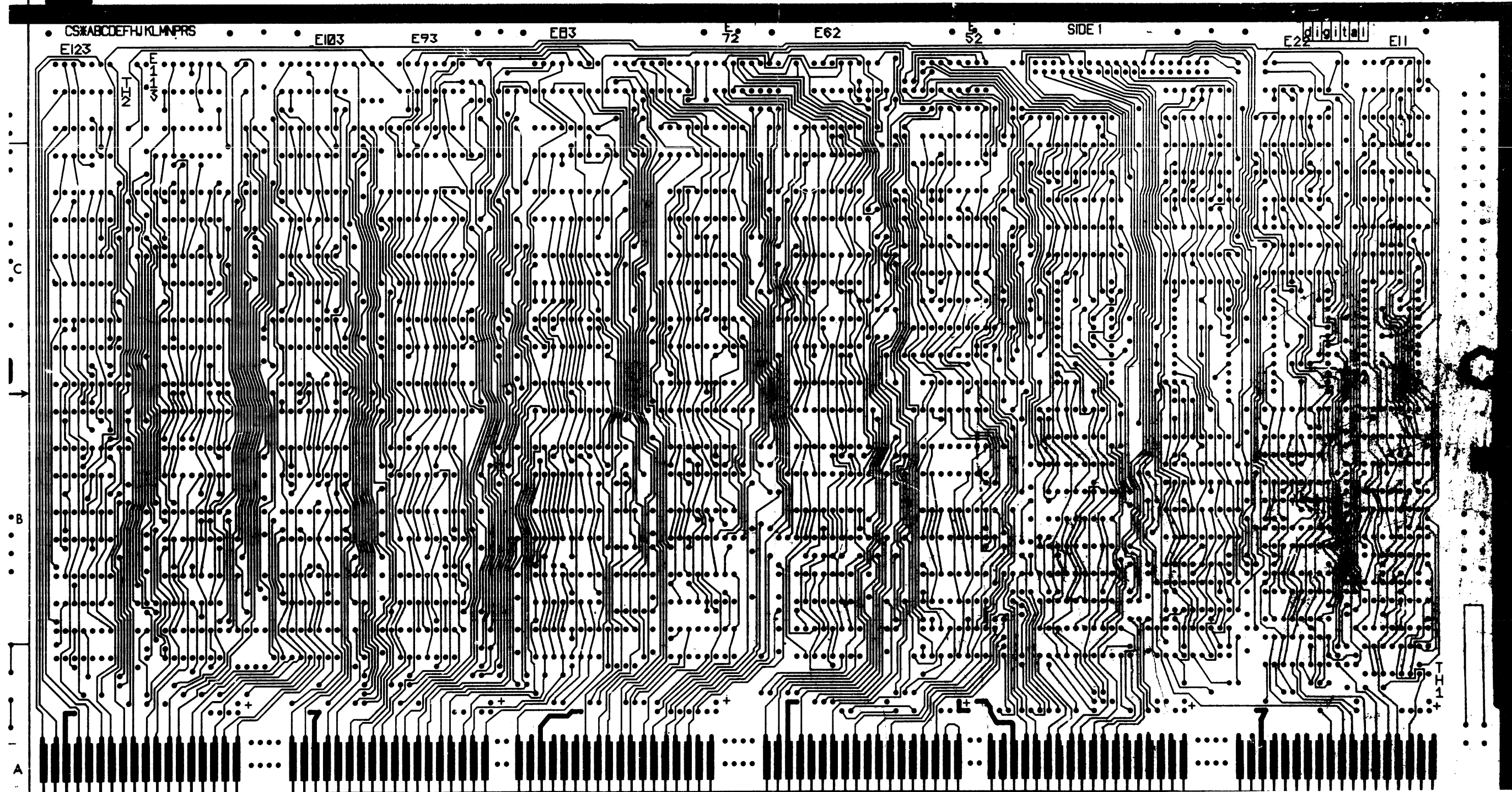

REVISIONS		
CHK	CHANGE NO	REV

TITLE	KD11-EA DATA PATH	SIZE CODE	DUA	NUMBER	M8265-0-0	REV.	
SCALE	2/1	SHEET	2	OF	3	DIS	

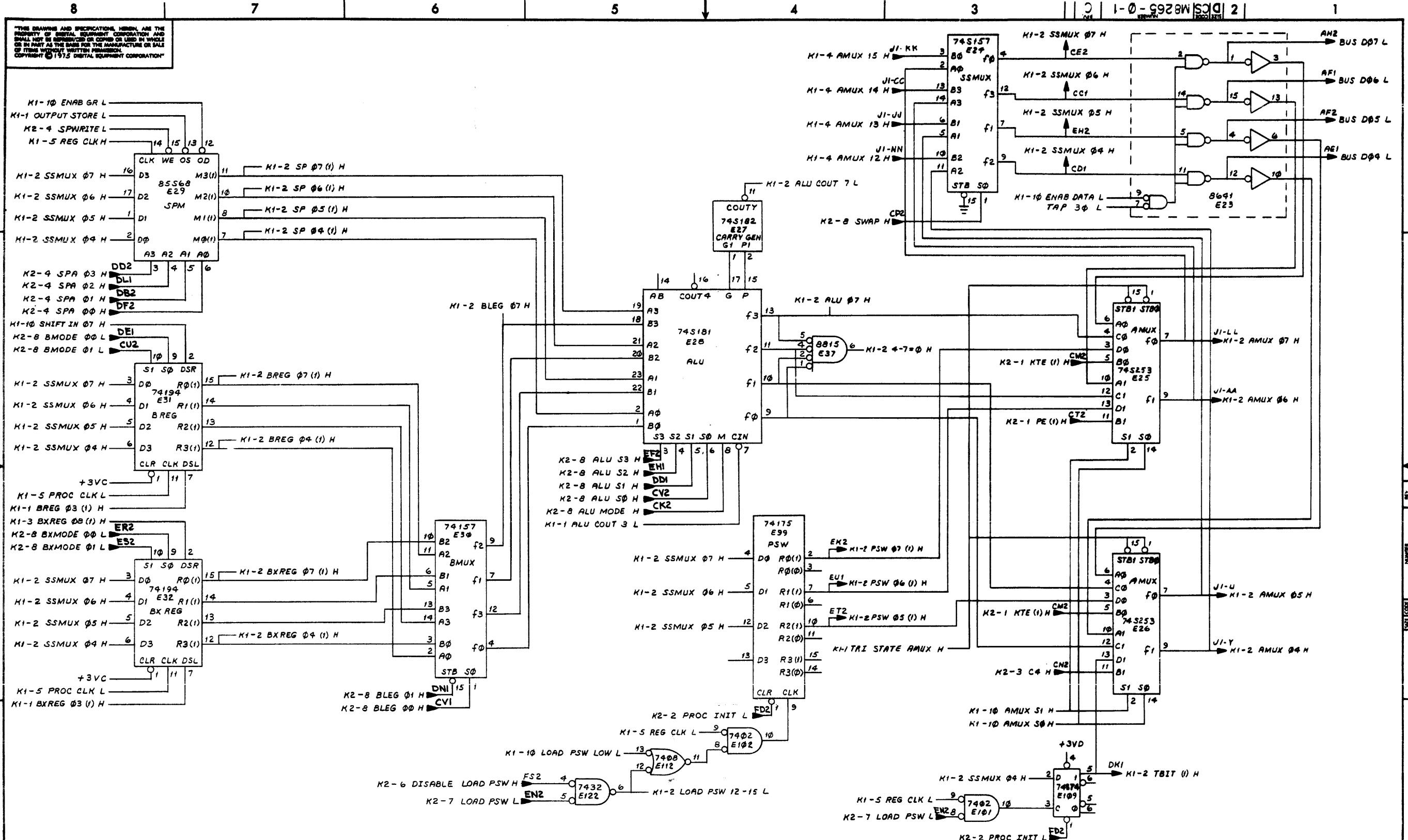

REVISIONS		
CHK	CHANGE NO.	REV.

TITLE	KD11EA DATA PATH (K1-2)	SIZE CODE	DCS M8265-0-1	NUMBER		REV.	C
SCALE	1/1	SHEET	2 OF 10	DIST.			

THE DRAWING AND SPECIFICATIONS HEREIN ARE THE PROPERTY OF GENERAL ELECTRIC CORPORATION AND SHALL NOT BE REPRODUCED OR COPIED IN WHOLE OR IN PART AS THE BASIS FOR THE MANUFACTURE OR SALE OF ITEMS UNLESS WRITTEN PERMISSION IS OBTAINED FROM GENERAL ELECTRIC CORPORATION. COPYRIGHT © 1975 DIGITAL EQUIPMENT CORPORATION

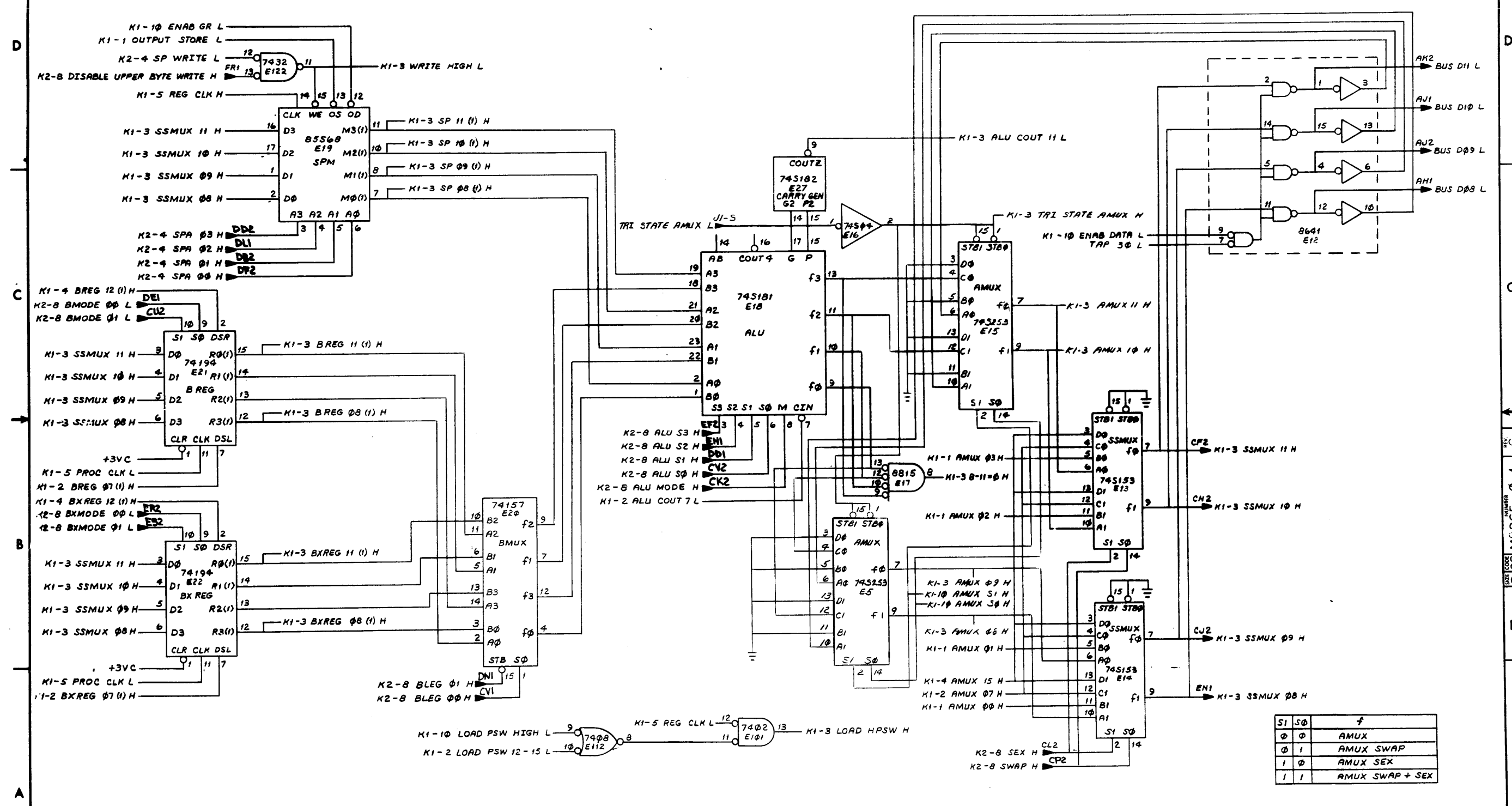

S1 S0	f
0 0	AMUX
0 1	AMUX SWAP
1 0	AMUX SEX
1 1	AMUX SWAP + SEX

(DATA PATH 8-11)

REVISIONS			TITLE	SIZE CODE	NUMBER	REV.
CHK	CHANGE NO.	REV.	KDI IEA DATA PATH (K1-3)	DCS	M8265-0-1	C

THE DRAWING AND SPECIFICATIONS HEREIN ARE THE PROPERTY OF DIGITAL EQUIPMENT CORPORATION AND SHALL NOT BE REPRODUCED OR COPIED OR USED IN WHOLE OR IN PART AS THE BASIS FOR THE MANUFACTURE OR SALE OF ITEMS WITHOUT WRITTEN PERMISSION. COPYRIGHT © 1975 DIGITAL EQUIPMENT CORPORATION

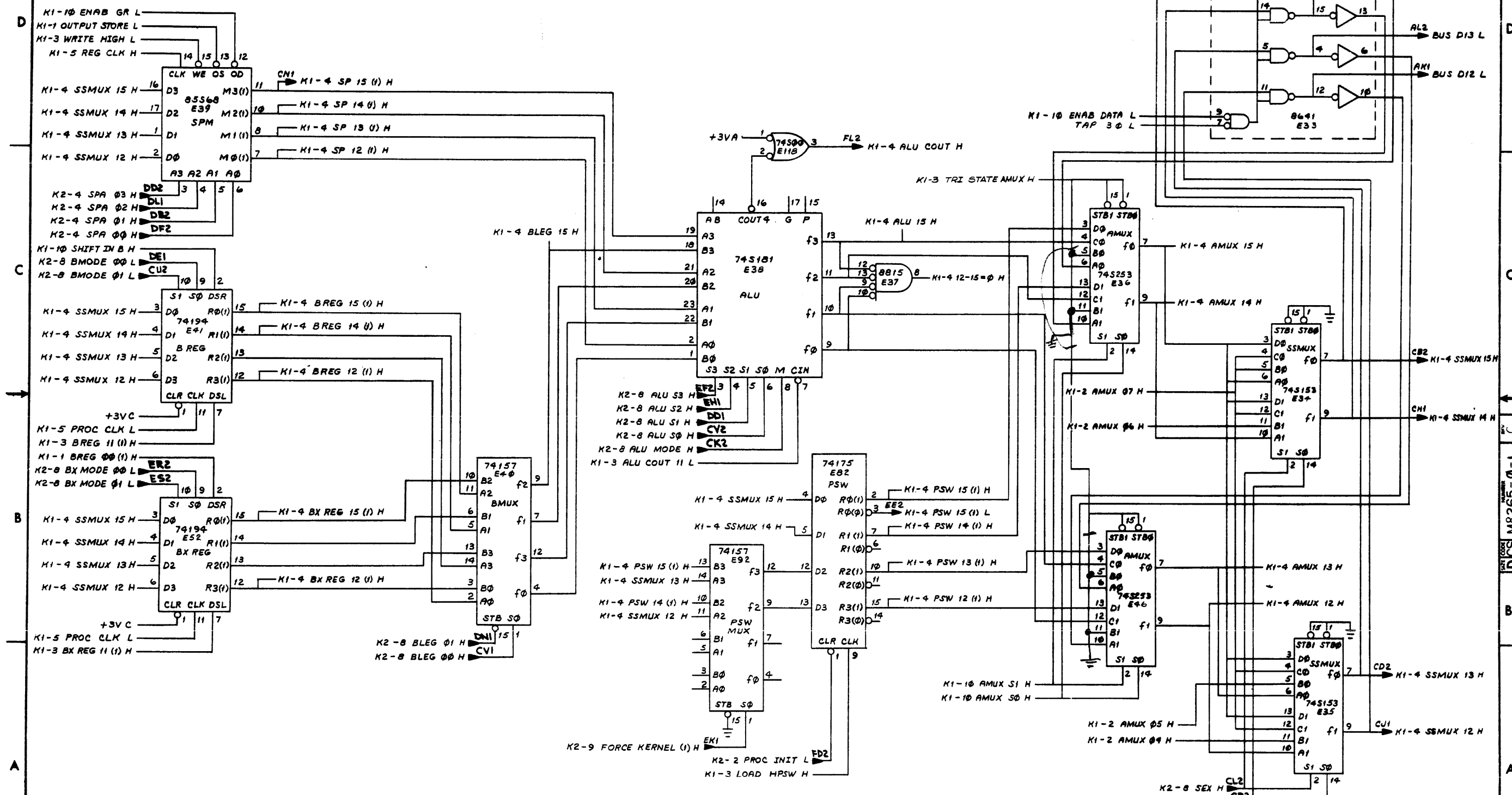

REVISIONS		
CHK	CHANGE NO.	REV.

"D-4 DRAWING AND SPECIFICATIONS HEREBY ARE THE PROPERTY OF DIGITAL EQUIPMENT CORPORATION AND SHALL NOT BE REPRODUCED OR COPIED OR USED IN WHOLE OR IN PART AS THE BASIS FOR THE MANUFACTURE OR SALE OF OTHER EQUIPMENT WITHOUT PERMISSION. COPYRIGHT © 1975 DIGITAL EQUIPMENT CORPORATION"

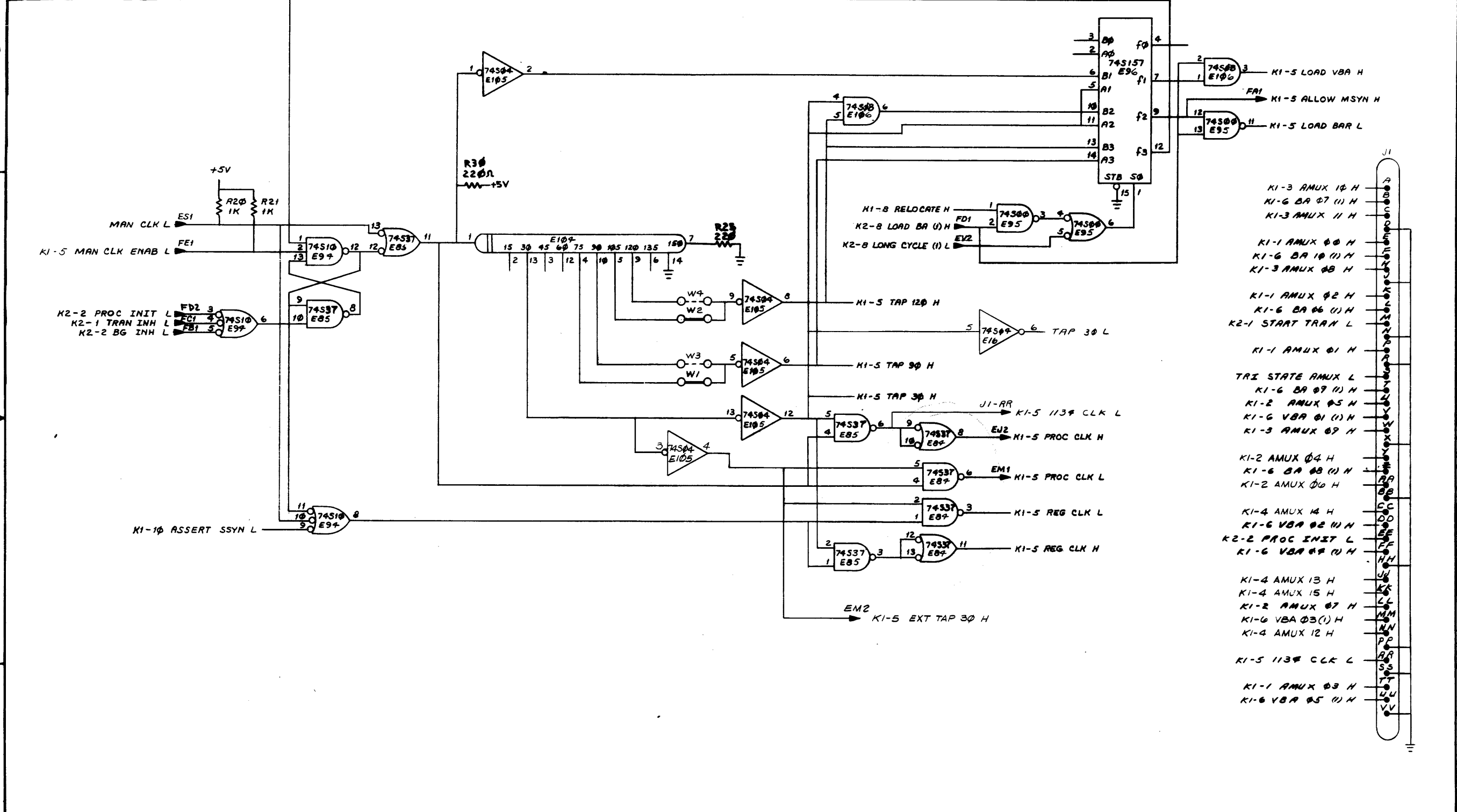

- KI-3 AMUX 10 H
- KI-6 BA 07 (1) H
- KI-3 AMUX 11 H

- KI-1 AMUX 00 H
- KI-6 BA 10 (1) H
- KI-3 AMUX 08 H

- KI-1 AMUX 02 H
- KI-6 BA 06 (1) H
- K2-1 START TRAN L

- KI-1 AMUX 01 H

- TRX STATE AMUX L
- KI-6 BA 09 (1) H
- KI-2 AMUX 05 H
- KI-6 VBA 01 (1) H
- KI-3 AMUX 09 H

- KI-2 AMUX 04 H
- KI-6 BA 08 (1) H
- KI-2 AMUX 00 H

- KI-4 AMUX 14 H
- KI-6 VBA 02 (1) H
- K2-2 PROC INIT L
- KI-6 VBA 04 (1) H

- KI-4 AMUX 13 H
- KI-4 AMUX 15 H
- KI-2 AMUX 07 H
- KI-6 VBA 03 (1) H
- KI-4 AMUX 12 H

- KI-5 113# CLK L

- KI-1 AMUX 03 H
- KI-6 VBA 05 (1) H

(CPU CLK)

REVISIONS		
CR	CHANGE NO.	REV.

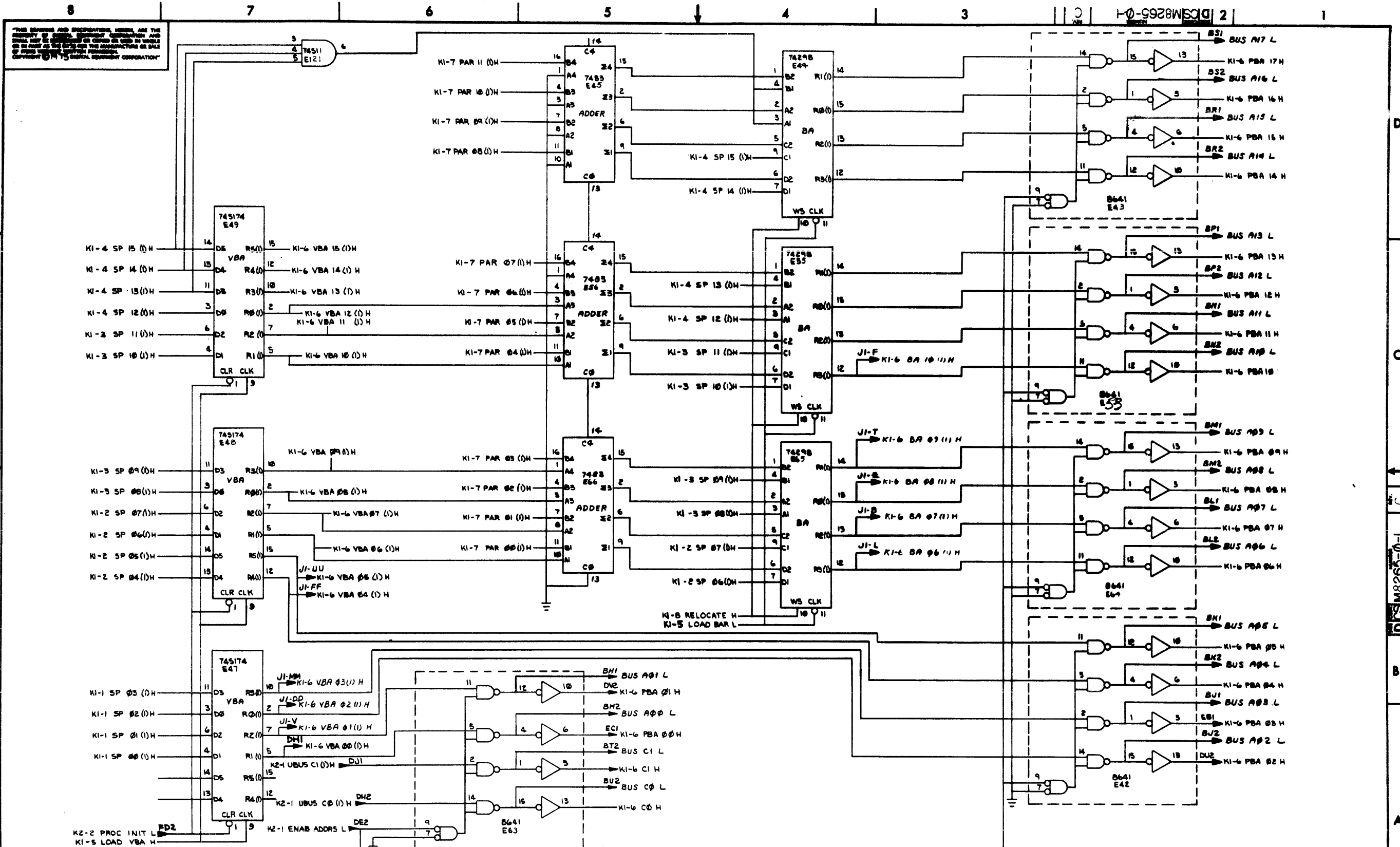

(UNIBUS ADDRESS)

REVISIONS		
CHK	CHANGE NO.	REV.

TITLE	SIZE CODE	NUMBER	REV.
KD11EA DATA PATH (KI-6)	D	CSM8265-0-1	C
SCALE	SHEET	6 OF 10	DIST.

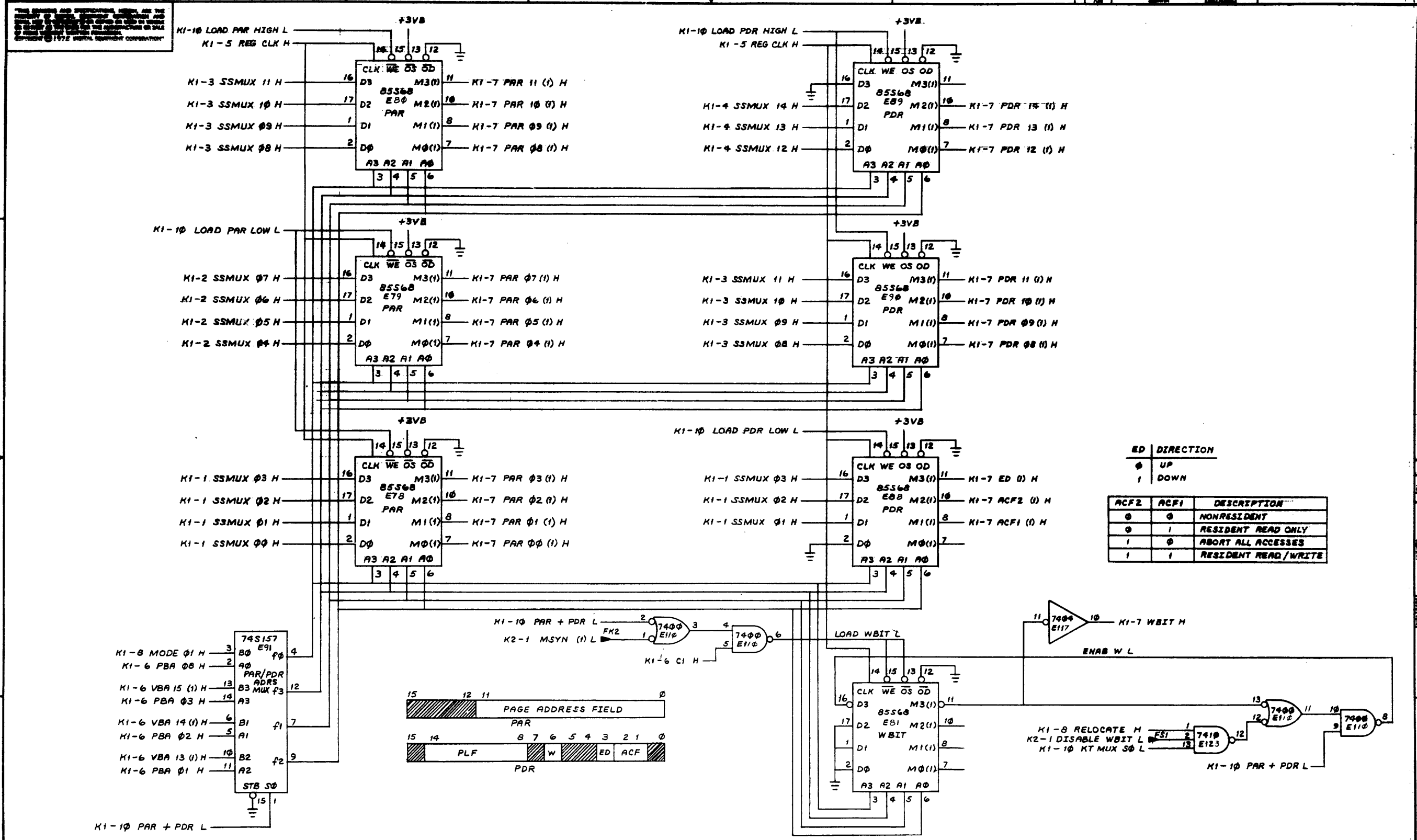

ED	DIRECTION	ACF2	ACF1	DESCRIPTION
0	UP	0	0	NONRESIDENT
0	DOWN	0	1	RESIDENT READ ONLY
1	DOWN	0	0	ABORT ALL ACCESSES
1	DOWN	1	1	RESIDENT READ/WRITE

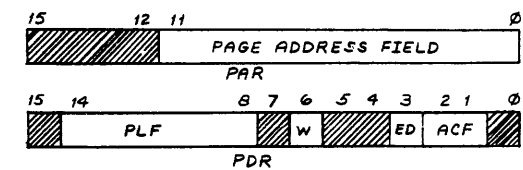

CH	CHANGE NO.	REV.

"THIS DRAWING AND SPECIFICATIONS HEREIN ARE THE PROPERTY OF DIGITAL EQUIPMENT CORPORATION AND SHALL NOT BE REPRODUCED OR COPIED OR USED IN WHOLE OR IN PART AS THE BASIS FOR THE MANUFACTURE OR SALE OF ITEMS WITHOUT WRITTEN PERMISSION. COPYRIGHT © 1975 DIGITAL EQUIPMENT CORPORATION"

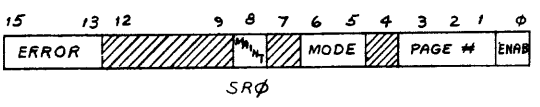
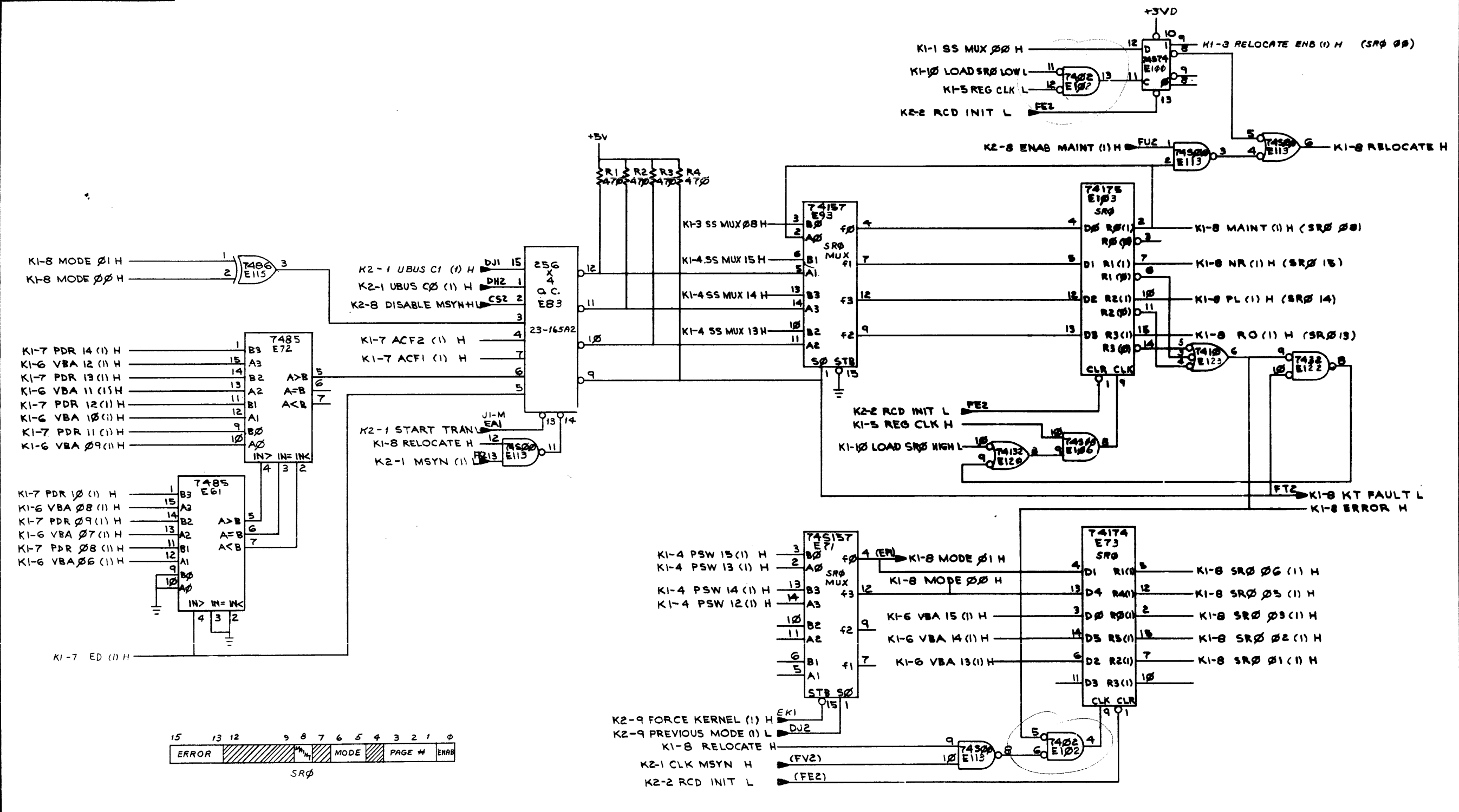

REVISIONS		
CHK	CHANGE NO.	REV.

TITLE	SIZE CODE	NUMBER	REV.
KI-8 DATA PATH (KI-8)	DCS M265-0-1		C
SCALE	SHEET	OF	DIST.
	8	10	

THE DRAWING AND SPECIFICATIONS HEREIN ARE THE PROPERTY OF DIGITAL EQUIPMENT CORPORATION AND SHALL NOT BE REPRODUCED OR COPIED OR USED IN WHOLE OR IN PART AS THE BASIS FOR THE MANUFACTURE OR SALE OF OTHER EQUIPMENT WITHOUT PERMISSION. COPYRIGHT © 1975 DIGITAL EQUIPMENT CORPORATION

SI	SØ	F
H	H	SRØ
H	L	SR2
L	H	PAR
L	L	PDR

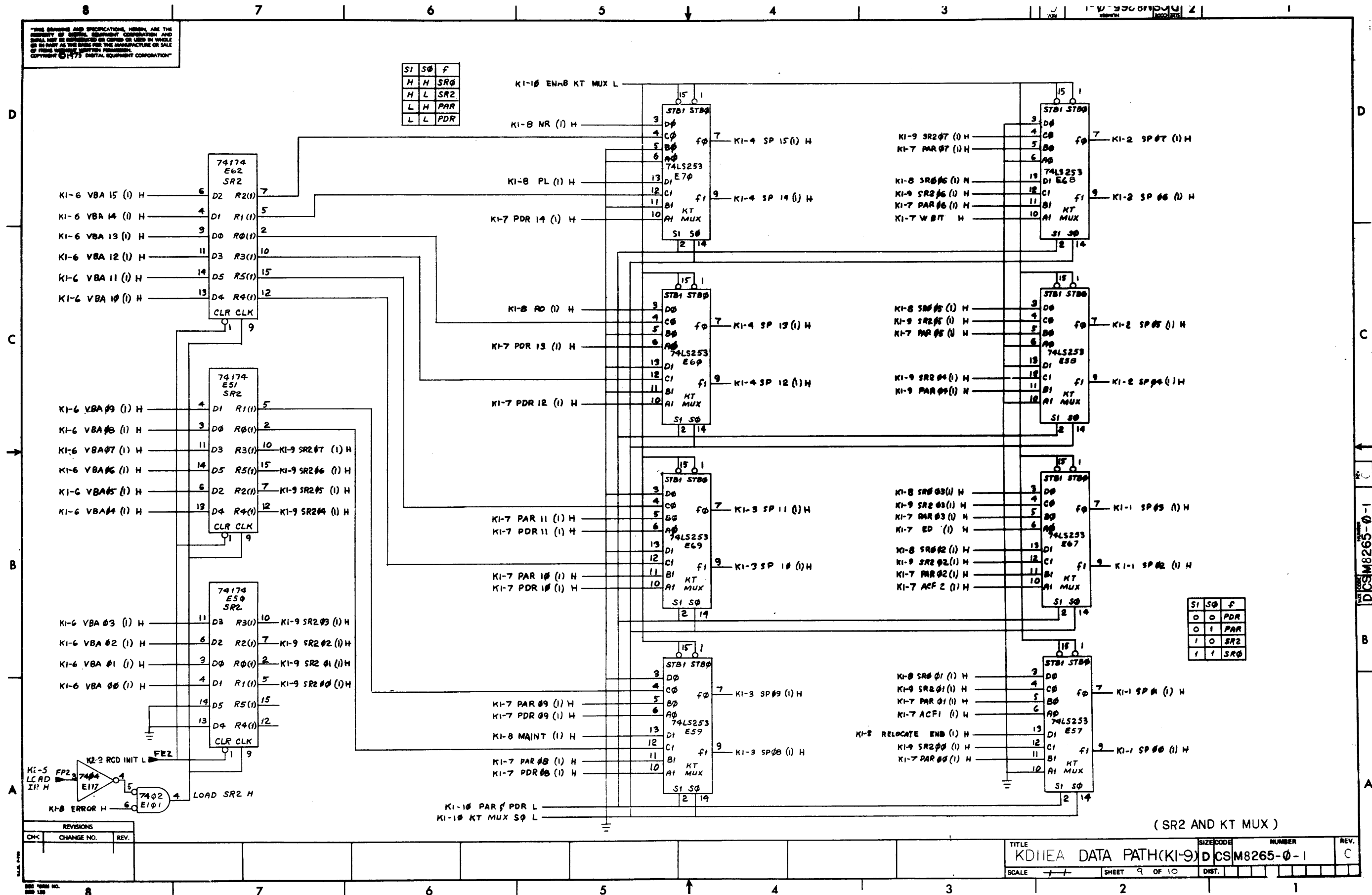

SI	SØ	F
0	0	PDR
0	1	PAR
1	0	SR2
1	1	SRØ

(SR2 AND KT MUX)

TITLE: KD11EA DATA PATH(KI-9) SIZE/SCALE: DIST. SHEET 9 OF 10 NUMBER: DCSM8265-Ø-1 REV. C

THIS DRAWING AND SPECIFICATIONS HEREON ARE THE PROPERTY OF DIGITAL EQUIPMENT CORPORATION AND SHALL NOT BE REPRODUCED OR COPIED OR USED IN WHOLE OR IN PART AS THE BASIS FOR THE MANUFACTURE OR SALE OF ITEMS WITHOUT WRITTEN PERMISSION. COPYRIGHT © 1976 DIGITAL EQUIPMENT CORPORATION

D
C
B
A

D
C
B
A

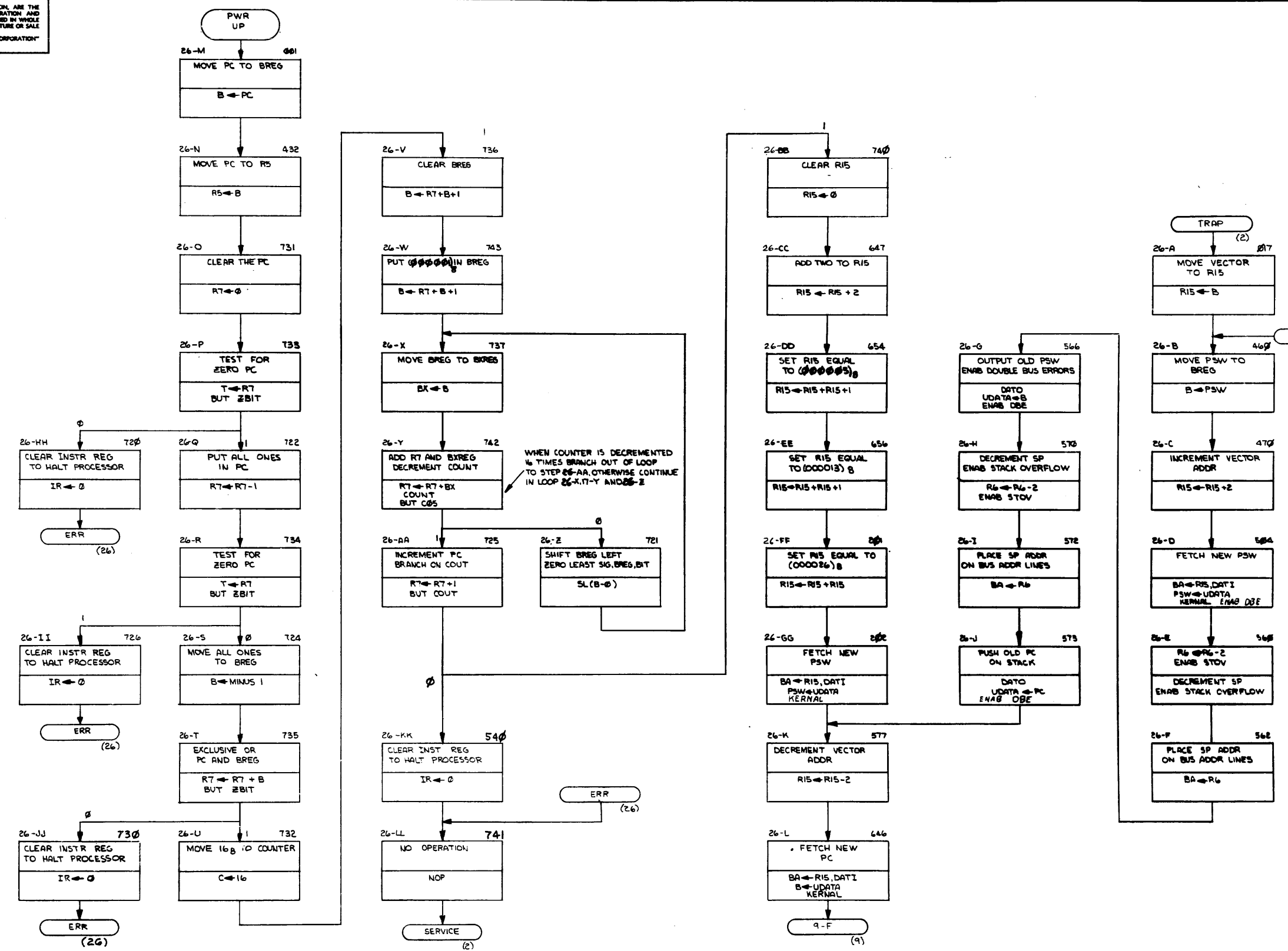

REVISIONS		
CHK	CHANGE NO.	REV.

DEC FORM NO. 138

ALL DIMENSIONS AND SPECIFICATIONS HEREIN ARE THE PROPERTY OF DIGITAL EQUIPMENT CORPORATION AND SHALL NOT BE REPRODUCED OR USED IN WHOLE OR IN PART AS THE BASIS FOR THE MANUFACTURE OR SALE OF ITEMS WITHOUT WRITTEN PERMISSION. COPYRIGHT © DIGITAL EQUIPMENT CORPORATION.

0 0-0-992811 70 2

LAYER 1

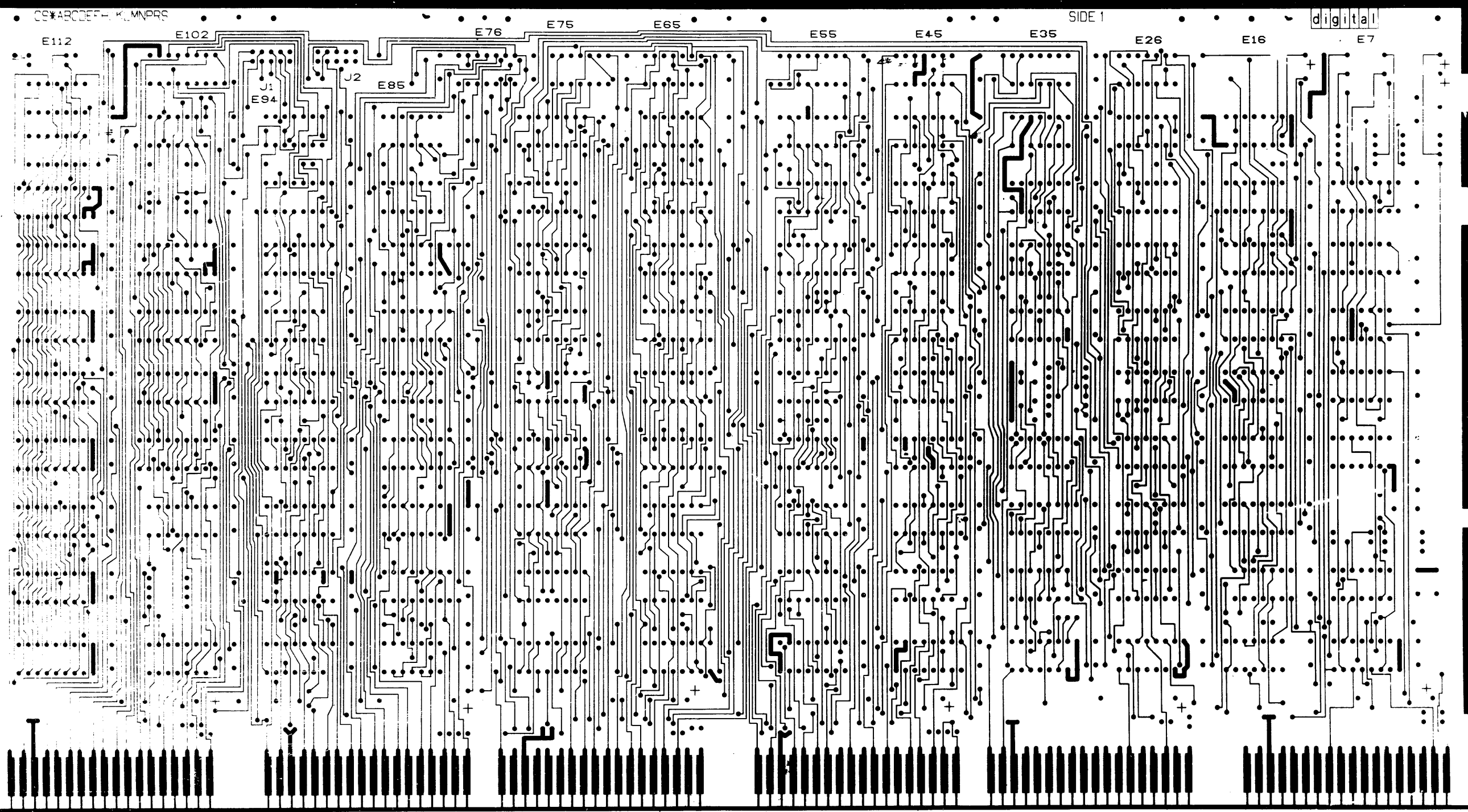

TITLE	KD11E-A CONTROL	SIZE CODE	D UA	NUMBER	M8266-0-0	REV.	D
SCALE	2-1	SHEET	2	OF	4	DIST.	

NO PART OF THIS DRAWING IS TO BE REPRODUCED OR TRANSMITTED IN ANY FORM OR BY ANY MEANS, ELECTRONIC OR MECHANICAL, INCLUDING PHOTOCOPYING, RECORDING, OR BY ANY INFORMATION STORAGE AND RETRIEVAL SYSTEM, WITHOUT THE WRITTEN PERMISSION OF DIGITAL EQUIPMENT CORPORATION.

834AJ

7-0-93261 12 2

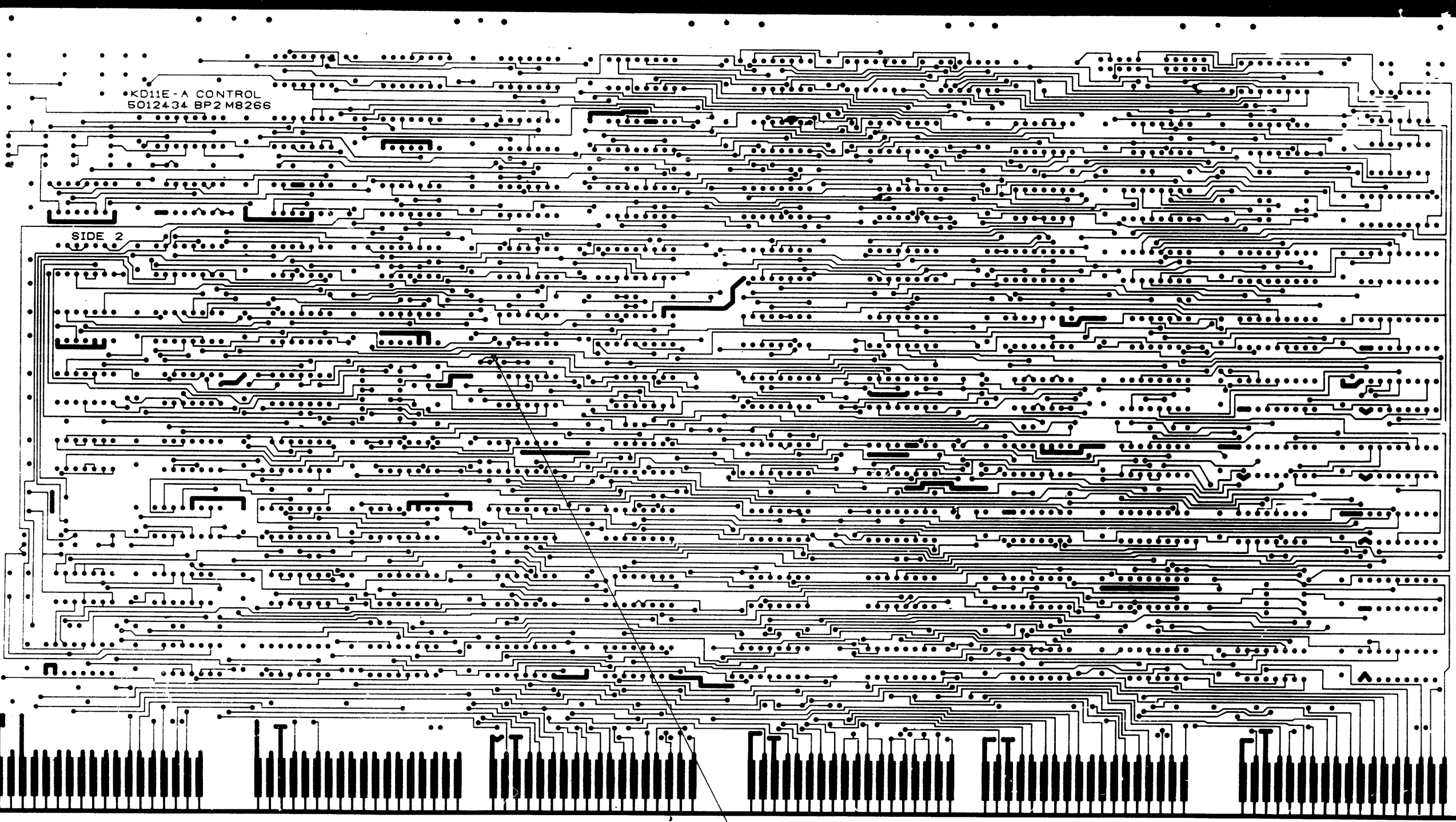

REVISIONS	
NO.	DESCRIPTION

TITLE	KD11E-A CONTROL	SIZE CODE	D JA	NUMBER	M8266-0-0	REV.	D
SCALE	2-1	SHEET	3	OF	4	DIST.	

REV. D
NUMBER M8266-0-0
D JA

8 7 6 5 4 3 2 1

DIGITAL EQUIPMENT CORPORATION PARTS LIST				QUANTITY / VARIATION										NOTES:							
MADE BY R. BARILONE DATE 19 JULY 77		CHECKED <i>A. Giannarino</i> DATE 9-6-77		SECTION																	
ENG DATE		PROD DATE		ISSUED SECTION																	
ITEM NO.	DRAWING NO.	PART NO.	DESCRIPTION	M8266-0-0																	REF DESIGNATION
21		1301401	RESISTOR, 750 OHM, 1/4W, 5%	1																	R6
22		1213506-00	RIGHT ANGLE HEADER, 20 PIN	1																	J1, J2
23		1905547	I.C. DEC 7474	5																	X E5, E12, E31, E32, E34
24		1905575	I.C. DEC 7400	5																	X E3, E15, E18, E28, E86
25		1905587	I.C. DEC 7473	2																	X E24, E45
26		1909004	I.C. DEC 7402	3																	X E22, E23, E43
27		1909705	I.C. DEC 8881	2																	X E8, E77
28		1909713	I.C. DEC 8815	2																	X E4, E30
29		1910533	I.C. DEC 74S03	5																	X E41, E64, E65, E76, E94
30		1909930	I.C. DEC 7405	2																	X E91, E101
31		1910018	I.C. DEC 74193	2																	X E78, E79
32		1911675	I.C. DEC 74S138	1																	X E89
33		1910091	I.C. DEC 7437	1																	X E81
34		1910155	I.C. DEC 7408	2																	X E11, E50
35		1910436	I.C. DEC 74123	3																	X E16, E7, E14
36		1910532	I.C. DEC 74S00	6																	X E25, E37, E47, E84, E6, E35
37		1910534	I.C. DEC 74S04	2																	X E111, E112
38		1910539	I.C. DEC 74S20	2																	X E57, E58
39		1910547	I.C. DEC 74S153	2																	X E46, E36
40		1910548	I.C. DEC S157	2																	X E10, E39

E.C.O. NO.

"THIS DRAWING AND SPECIFICATIONS, HEREIN, ARE THE PROPERTY OF DIGITAL EQUIPMENT CORPORATION AND SHALL NOT BE REPRODUCED OR COPIED OR USED IN WHOLE OR IN PART AS THE BASIS FOR THE MANUFACTURE OR SALE OF ITEMS WITHOUT WRITTEN PERMISSION. COPYRIGHT © 1977 DIGITAL EQUIPMENT CORPORATION"

TITLE
KD11E-A CONTROL

ASSY NO.
D-UA-M8266-0-0

SIZE
B

CODE
PL

NUMBER
M8266-0-0

REV.
C

SHEET 2 OF 5

INSERTION PARTS LIST DATA BASE REV B-P2

DIGITAL EQUIPMENT CORPORATION PARTS LIST				QUANTITY / VARIATION												NOTES:			
MADE BY R. BARILONE DATE 19 JULY 77		CHECKED <i>L. Giannarino</i> DATE 9-6-77																	
ENG _____ DATE _____		PROD _____ DATE _____																	
ITEM NO.	DRAWING NO.	PART NO.	DESCRIPTION	M8266-0-0															REF DESIGNATION
41		1910550	I.C. DEC 74S174	10															E19, E38, E66, E93, E71, E88, E90, E92, E96, E56
42		1910651	I.C. DEC 74175	1															E13
43		1910878	I.C. DEC 7427	1															E75
44		1910957	I.C. DEC 74S175	3															E48, E55, E67
45		1911116	I.C. DEC 8837	2															E1, E17
46		1911324	I.C. DEC 7414	1															E21
47		1911469	I.C. DEC 8640	1															E9
48		1911579	I.C. DEC 8641	1															E27
49		1911637	I.C. DEC 74132	2															E2, E42
50		1912388	I.C. DEC 74S02	3															E20, E73, E95
51		1912746	I.C. DEC 74S37	1															E26
52		1910544	I.C. DEC 74S74	2															E33, E49
53		1910536	I.C. DEC 74S10	2															E40, E85
54		1913340	I.C. DEC 74S32	1														*	E44
55		23106A1	I.C. ROM 32 x 8 TS	1															E51
56		23160A2	I.C. ROM 256 x 4 TS	1															E29
57		23175A2	I.C. ROM 256 x 4 OC	1															E53
58		23162A2	I.C. ROM 256 x 4 OC	1															E54
59		23174A2	I.C. ROM 256 x 4 OC	1															E59
60		23173A2	I.C. ROM 256 x 4 OC	1															E60
61		23161A2	I.C. ROM 256 x 4 TS	1															E61

E.C.O. NO. _____

"THIS DRAWING AND SPECIFICATIONS, HEREIN, ARE THE PROPERTY OF DIGITAL EQUIPMENT CORPORATION AND SHALL NOT BE REPRODUCED OR COPIED OR USED IN WHOLE OR IN PART AS THE BASIS FOR THE MANUFACTURE OR SALE OF ITEMS WITHOUT WRITTEN PERMISSION. COPYRIGHT © 1977 DIGITAL EQUIPMENT CORPORATION"

TITLE
KD11E-A CONTROL

ASSY NO.
D-UA-M8266-0-0

SIZE
B

CODE
PL

NUMBER
M8266-0-0

REV.
C

SHEET 3 OF 5

INSERTION PARTS LIST DATA BASE REV B-P2

DIGITAL EQUIPMENT CORPORATION PARTS LIST

QUANTITY / VARIATION

NOTES:

MADE BY	R. BARILONE	CHECKED	SECTION
DATE	19 JULY 77	DATE	9-6-77
ENG		PROD	
DATE		DATE	
		ISSUED SECTION	

M8266-0-0

ITEM NO.	DRAWING NO.	PART NO.	DESCRIPTION	1	2	3	4	5	6	7	8	9	10	11	12	13	14	15	16	17	18	19	20	21	22	23	24	25	26	27	28	29	30	31	32	33	34	35	36	37	38	39	40	41	42	43	44	45	46	47	48	49	50	51	52	53	54	55	56	57	58	59	60	61	62	63	64	65	66	67	68	69	70	71	72	73	74	75	76	77	78	79	80	81	82	83	84	85	86	87	88	89	90	91	92	93	94	95	96	97	98	99	100	101	102	103	104	105	106	107	108	109	110	111	112	113	114	115	116	117	118	119	120	121	122	123	124	125	126	127	128	129	130	131	132	133	134	135	136	137	138	139	140	141	142	143	144	145	146	147	148	149	150	151	152	153	154	155	156	157	158	159	160	161	162	163	164	165	166	167	168	169	170	171	172	173	174	175	176	177	178	179	180	181	182	183	184	185	186	187	188	189	190	191	192	193	194	195	196	197	198	199	200	201	202	203	204	205	206	207	208	209	210	211	212	213	214	215	216	217	218	219	220	221	222	223	224	225	226	227	228	229	230	231	232	233	234	235	236	237	238	239	240	241	242	243	244	245	246	247	248	249	250	251	252	253	254	255	256	257	258	259	260	261	262	263	264	265	266	267	268	269	270	271	272	273	274	275	276	277	278	279	280	281	282	283	284	285	286	287	288	289	290	291	292	293	294	295	296	297	298	299	300	301	302	303	304	305	306	307	308	309	310	311	312	313	314	315	316	317	318	319	320	321	322	323	324	325	326	327	328	329	330	331	332	333	334	335	336	337	338	339	340	341	342	343	344	345	346	347	348	349	350	351	352	353	354	355	356	357	358	359	360	361	362	363	364	365	366	367	368	369	370	371	372	373	374	375	376	377	378	379	380	381	382	383	384	385	386	387	388	389	390	391	392	393	394	395	396	397	398	399	400	401	402	403	404	405	406	407	408	409	410	411	412	413	414	415	416	417	418	419	420	421	422	423	424	425	426	427	428	429	430	431	432	433	434	435	436	437	438	439	440	441	442	443	444	445	446	447	448	449	450	451	452	453	454	455	456	457	458	459	460	461	462	463	464	465	466	467	468	469	470	471	472	473	474	475	476	477	478	479	480	481	482	483	484	485	486	487	488	489	490	491	492	493	494	495	496	497	498	499	500	501	502	503	504	505	506	507	508	509	510	511	512	513	514	515	516	517	518	519	520	521	522	523	524	525	526	527	528	529	530	531	532	533	534	535	536	537	538	539	540	541	542	543	544	545	546	547	548	549	550	551	552	553	554	555	556	557	558	559	560	561	562	563	564	565	566	567	568	569	570	571	572	573	574	575	576	577	578	579	580	581	582	583	584	585	586	587	588	589	590	591	592	593	594	595	596	597	598	599	600	601	602	603	604	605	606	607	608	609	610	611	612	613	614	615	616	617	618	619	620	621	622	623	624	625	626	627	628	629	630	631	632	633	634	635	636	637	638	639	640	641	642	643	644	645	646	647	648	649	650	651	652	653	654	655	656	657	658	659	660	661	662	663	664	665	666	667	668	669	670	671	672	673	674	675	676	677	678	679	680	681	682	683	684	685	686	687	688	689	690	691	692	693	694	695	696	697	698	699	700	701	702	703	704	705	706	707	708	709	710	711	712	713	714	715	716	717	718	719	720	721	722	723	724	725	726	727	728	729	730	731	732	733	734	735	736	737	738	739	740	741	742	743	744	745	746	747	748	749	750	751	752	753	754	755	756	757	758	759	760	761	762	763	764	765	766	767	768	769	770	771	772	773	774	775	776	777	778	779	780	781	782	783	784	785	786	787	788	789	790	791	792	793	794
----------	-------------	----------	-------------	---	---	---	---	---	---	---	---	---	----	----	----	----	----	----	----	----	----	----	----	----	----	----	----	----	----	----	----	----	----	----	----	----	----	----	----	----	----	----	----	----	----	----	----	----	----	----	----	----	----	----	----	----	----	----	----	----	----	----	----	----	----	----	----	----	----	----	----	----	----	----	----	----	----	----	----	----	----	----	----	----	----	----	----	----	----	----	----	----	----	----	----	----	----	----	----	----	----	----	-----	-----	-----	-----	-----	-----	-----	-----	-----	-----	-----	-----	-----	-----	-----	-----	-----	-----	-----	-----	-----	-----	-----	-----	-----	-----	-----	-----	-----	-----	-----	-----	-----	-----	-----	-----	-----	-----	-----	-----	-----	-----	-----	-----	-----	-----	-----	-----	-----	-----	-----	-----	-----	-----	-----	-----	-----	-----	-----	-----	-----	-----	-----	-----	-----	-----	-----	-----	-----	-----	-----	-----	-----	-----	-----	-----	-----	-----	-----	-----	-----	-----	-----	-----	-----	-----	-----	-----	-----	-----	-----	-----	-----	-----	-----	-----	-----	-----	-----	-----	-----	-----	-----	-----	-----	-----	-----	-----	-----	-----	-----	-----	-----	-----	-----	-----	-----	-----	-----	-----	-----	-----	-----	-----	-----	-----	-----	-----	-----	-----	-----	-----	-----	-----	-----	-----	-----	-----	-----	-----	-----	-----	-----	-----	-----	-----	-----	-----	-----	-----	-----	-----	-----	-----	-----	-----	-----	-----	-----	-----	-----	-----	-----	-----	-----	-----	-----	-----	-----	-----	-----	-----	-----	-----	-----	-----	-----	-----	-----	-----	-----	-----	-----	-----	-----	-----	-----	-----	-----	-----	-----	-----	-----	-----	-----	-----	-----	-----	-----	-----	-----	-----	-----	-----	-----	-----	-----	-----	-----	-----	-----	-----	-----	-----	-----	-----	-----	-----	-----	-----	-----	-----	-----	-----	-----	-----	-----	-----	-----	-----	-----	-----	-----	-----	-----	-----	-----	-----	-----	-----	-----	-----	-----	-----	-----	-----	-----	-----	-----	-----	-----	-----	-----	-----	-----	-----	-----	-----	-----	-----	-----	-----	-----	-----	-----	-----	-----	-----	-----	-----	-----	-----	-----	-----	-----	-----	-----	-----	-----	-----	-----	-----	-----	-----	-----	-----	-----	-----	-----	-----	-----	-----	-----	-----	-----	-----	-----	-----	-----	-----	-----	-----	-----	-----	-----	-----	-----	-----	-----	-----	-----	-----	-----	-----	-----	-----	-----	-----	-----	-----	-----	-----	-----	-----	-----	-----	-----	-----	-----	-----	-----	-----	-----	-----	-----	-----	-----	-----	-----	-----	-----	-----	-----	-----	-----	-----	-----	-----	-----	-----	-----	-----	-----	-----	-----	-----	-----	-----	-----	-----	-----	-----	-----	-----	-----	-----	-----	-----	-----	-----	-----	-----	-----	-----	-----	-----	-----	-----	-----	-----	-----	-----	-----	-----	-----	-----	-----	-----	-----	-----	-----	-----	-----	-----	-----	-----	-----	-----	-----	-----	-----	-----	-----	-----	-----	-----	-----	-----	-----	-----	-----	-----	-----	-----	-----	-----	-----	-----	-----	-----	-----	-----	-----	-----	-----	-----	-----	-----	-----	-----	-----	-----	-----	-----	-----	-----	-----	-----	-----	-----	-----	-----	-----	-----	-----	-----	-----	-----	-----	-----	-----	-----	-----	-----	-----	-----	-----	-----	-----	-----	-----	-----	-----	-----	-----	-----	-----	-----	-----	-----	-----	-----	-----	-----	-----	-----	-----	-----	-----	-----	-----	-----	-----	-----	-----	-----	-----	-----	-----	-----	-----	-----	-----	-----	-----	-----	-----	-----	-----	-----	-----	-----	-----	-----	-----	-----	-----	-----	-----	-----	-----	-----	-----	-----	-----	-----	-----	-----	-----	-----	-----	-----	-----	-----	-----	-----	-----	-----	-----	-----	-----	-----	-----	-----	-----	-----	-----	-----	-----	-----	-----	-----	-----	-----	-----	-----	-----	-----	-----	-----	-----	-----	-----	-----	-----	-----	-----	-----	-----	-----	-----	-----	-----	-----	-----	-----	-----	-----	-----	-----	-----	-----	-----	-----	-----	-----	-----	-----	-----	-----	-----	-----	-----	-----	-----	-----	-----	-----	-----	-----	-----	-----	-----	-----	-----	-----	-----	-----	-----	-----	-----	-----	-----	-----	-----	-----	-----	-----	-----	-----	-----	-----	-----	-----	-----	-----	-----	-----	-----	-----	-----	-----	-----	-----	-----	-----	-----	-----	-----	-----	-----	-----	-----	-----	-----	-----	-----	-----	-----	-----	-----	-----	-----	-----	-----	-----	-----	-----	-----	-----	-----	-----	-----	-----	-----	-----	-----	-----	-----	-----	-----	-----	-----	-----	-----	-----	-----	-----	-----	-----	-----	-----	-----	-----	-----	-----	-----	-----	-----	-----	-----	-----	-----	-----	-----	-----	-----	-----	-----	-----	-----	-----	-----	-----	-----

DIGITAL EQUIPMENT CORPORATION PARTS LIST				QUANTITY / VARIATION										NOTES:
MADE BY DATE		R. BARILONE 19 JULY 77		CHECKED DATE		<i>L. Gianmarino</i> 9-6-77		SECTION						REF DESIGNATION
ENG DATE		PROD DATE		ISSUED SECTION										
ITEM NO.	DRAWING NO.	PART NO.	DESCRIPTION	MB266-0-0										
83		23017F1	I.C. ROM 1024 x 4 TS	1									E109	
84		23016F1	I.C. ROM 1024 x 4 TS	1									E110	
85		23177A1	I.C. ROM 32 x 8 TS	1									E102	
86		23013F1	I.C. ROM 1024 x 4 TS	1							X		E52	
87		9009185	JUMPER, MACHINE INSERT, INSL.	1									W1	
88		9006732	EYELET, HANDLE GS4 - 7	12										
89		7417214	HANDLE ASSY	1										
90		1303114	RESISTOR 1K 1% 1/4W	1									R2	
91														
92														
93														

E.C.O. NO.	"THIS DRAWING AND SPECIFICATIONS, HEREIN, ARE THE PROPERTY OF DIGITAL EQUIPMENT CORPORATION AND SHALL NOT BE REPRODUCED OR COPIED OR USED IN WHOLE OR IN PART AS THE BASIS FOR THE MANUFACTURE OR SALE OF ITEMS WITHOUT WRITTEN PERMISSION. COPYRIGHT © 1977 DIGITAL EQUIPMENT CORPORATION"			TITLE KD11E-A CONTROL	ASSY NO. D-UA-M8266-0-0	SIZE B	CODE PL	NUMBER M8266-0-0	REV. C
	SHEET 5 OF 5		INSERTION PARTS LIST DATA BASE REV B-P2						

THIS DRAWING AND SPECIFICATIONS HEREIN ARE THE PROPERTY OF DIGITAL EQUIPMENT CORPORATION AND SHALL NOT BE REPRODUCED OR COPIED OR USED IN WHOLE OR IN PART AS THE BASIS FOR THE MANUFACTURE OR SALE OF ITEMS WITHOUT WRITTEN PERMISSION. COPYRIGHT © 1975 DIGITAL EQUIPMENT CORPORATION.

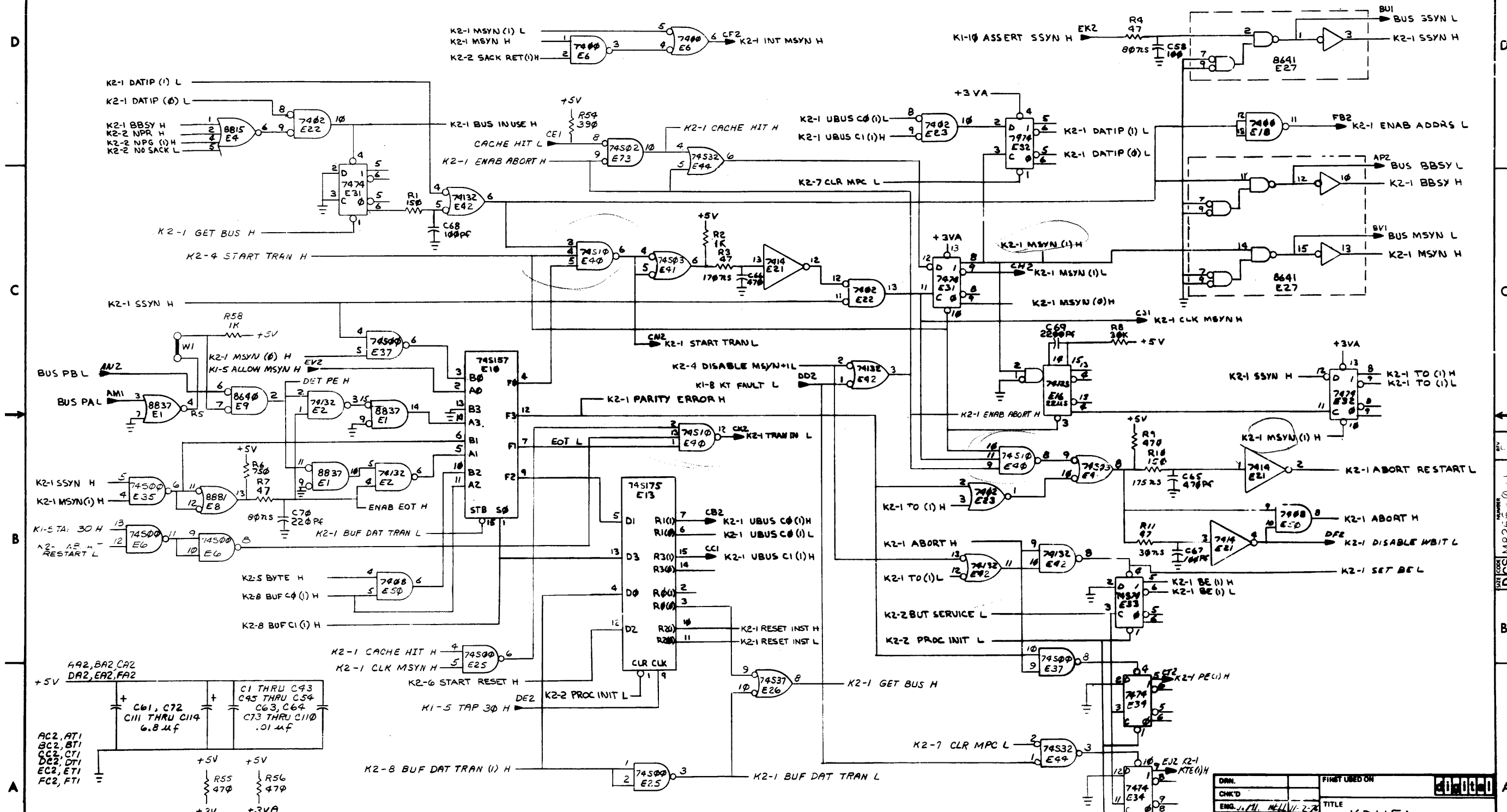

REVISIONS	
CHK	CHANGE NO.
A	1
B	2
C	3
D	4

NO.	REV.	DATE	BY	CHK'D	DESCRIPTION
1	A	11/11/75	R. BARRY	M. SULLIVAN	INITIAL DESIGN
2	B	11/11/75	R. BARRY	M. SULLIVAN	REVISIONS
3	C	11/11/75	R. BARRY	M. SULLIVAN	REVISIONS
4	D	11/11/75	R. BARRY	M. SULLIVAN	REVISIONS

DRN.	FIRST USED ON
CHK'D	TITLE
ENG. J. M. MULLIN 11-2-75	KD11EA CONTROL (K2-1)
PROJ. ENG. J. M. MULLIN 11-2-75	SIZE CODE
PROD. R. K. KANE 11-2-75	NUMBER
NEXT HIGHER ASSY.	DIST.
SCALE	D E S M 8 2 6 6 - 0 - 1
SHEET 1 OF 10	REV. D

A

THIS DRAWING AND SPECIFICATIONS HEREIN ARE THE PROPERTY OF DIGITAL EQUIPMENT CORPORATION AND SHALL NOT BE REPRODUCED OR COPIED OR USED IN WHOLE OR IN PART AS THEY ARE OR FOR THE MANUFACTURE OR SALE OF OTHER EQUIPMENT WITHOUT THE WRITTEN PERMISSION OF DIGITAL EQUIPMENT CORPORATION © 1972

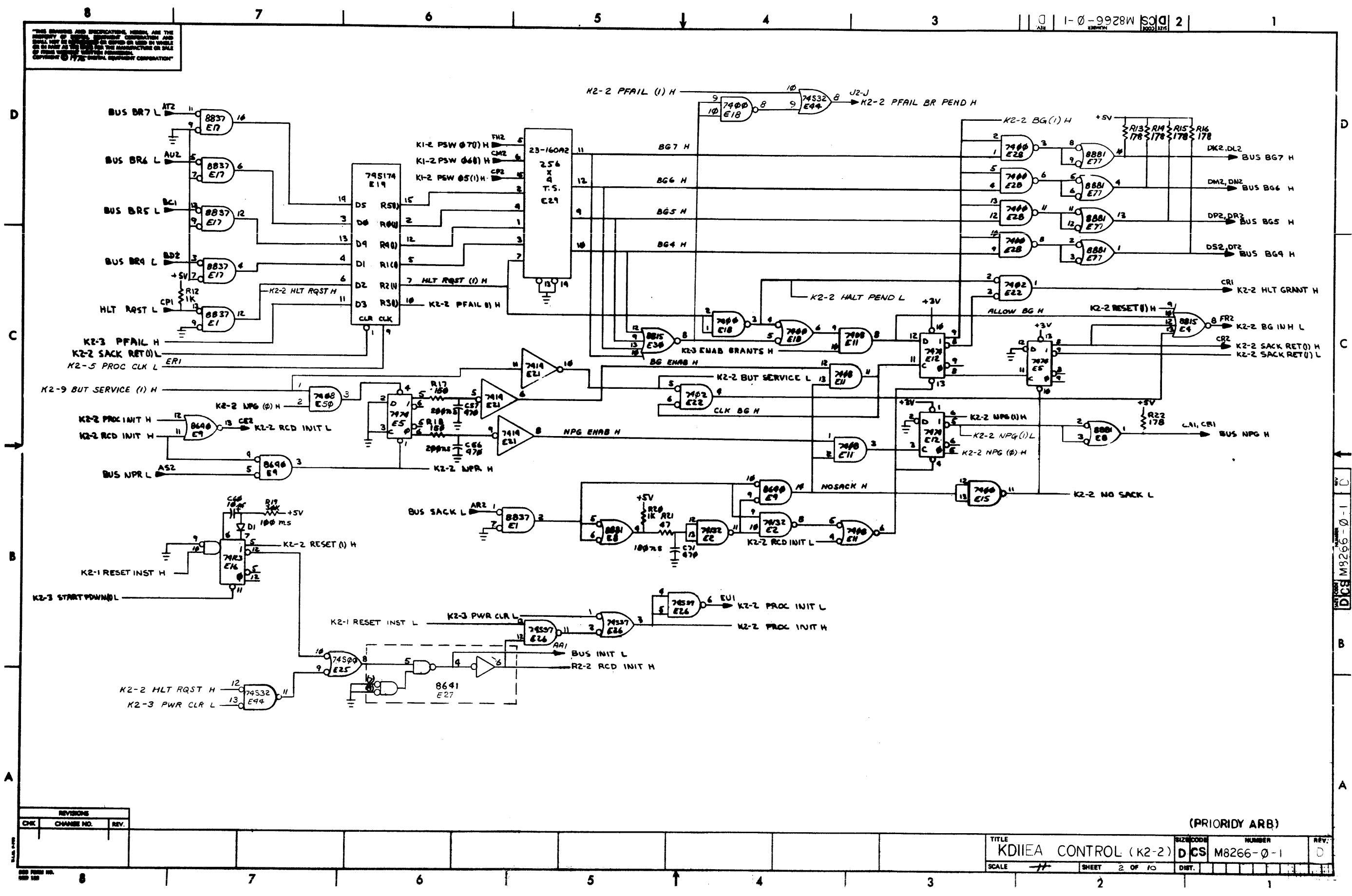

REVISIONS		
CHK	CHANGE NO.	REV.

TITLE		KDIIEA CONTROL (K2-2)		SIZE	CODE	NUMBER	REV.
SCALE		1/1		D CS		M8266-0-1	D
SHEET		2 OF 10		DST.			

(PRIORITY ARB)

D CS M8266-0-1

"THIS DRAWING AND SPECIFICATIONS, HEREIN, ARE THE PROPERTY OF DIGITAL EQUIPMENT CORPORATION AND SHALL NOT BE REPRODUCED OR COPIED OR USED IN WHOLE OR IN PART AS THE BASIS FOR THE MANUFACTURE OR SALE OF ITEMS WITHOUT WRITTEN PERMISSION. COPYRIGHT © 1975 DIGITAL EQUIPMENT CORPORATION"

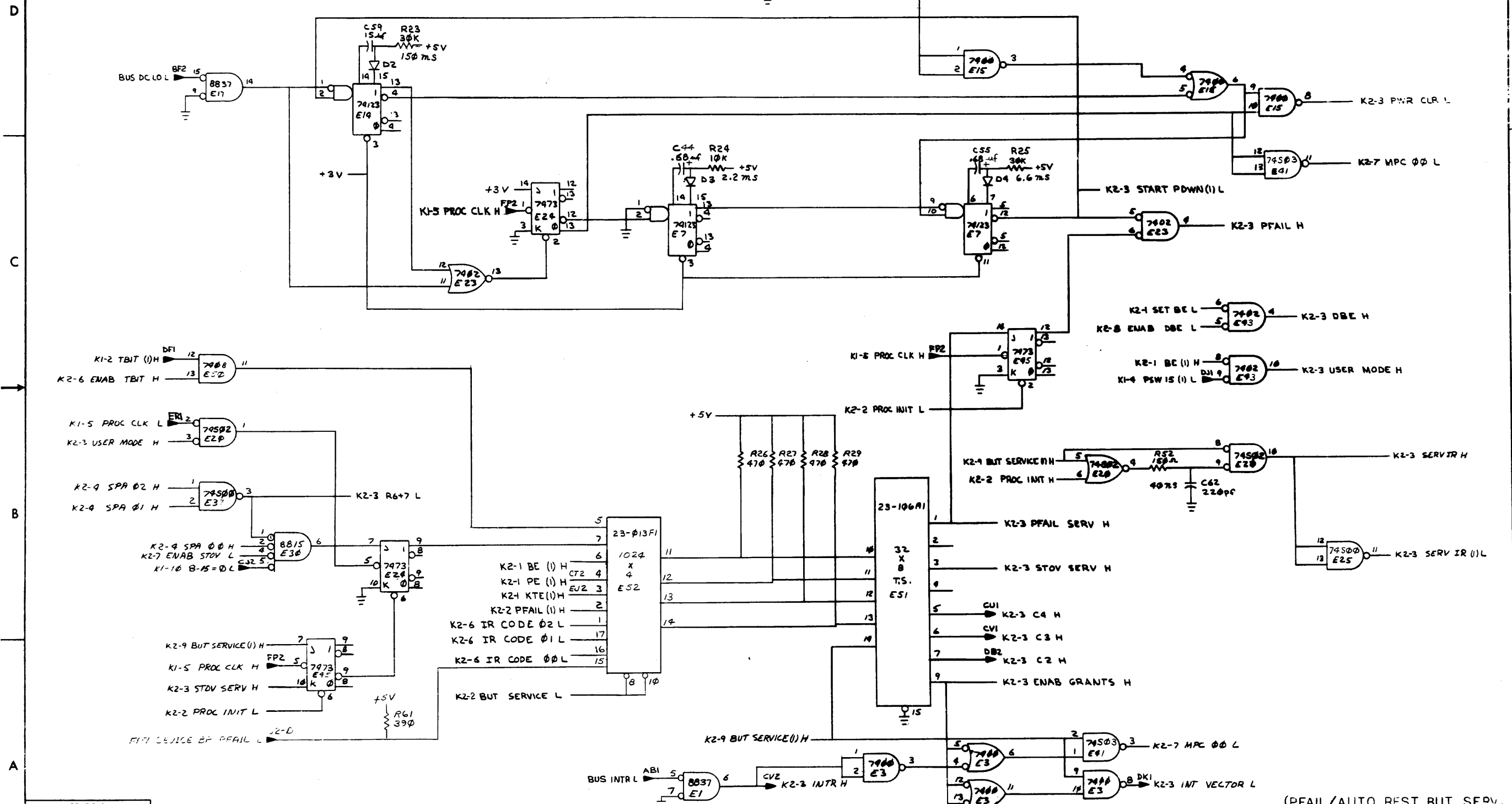
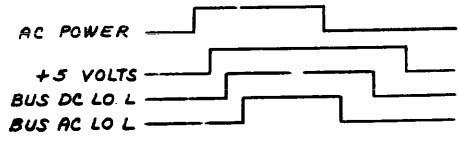

REVISIONS		
CHK	CHANGE NO.	REV

TITLE	KDII EA CONTROL (K2-3)	SIZE CODE	DCS	NUMBER	M8266-0-1	REV.	
SCALE		SHEET	3 OF 10	DIST.			

REV. NUMBER M8266-0-1

THIS DRAWING AND SPECIFICATIONS HEREIN ARE THE PROPERTY OF DIGITAL EQUIPMENT CORPORATION AND SHALL NOT BE REPRODUCED OR COPIED OR USED IN WHOLE OR IN PART AS THE BASIS FOR THE MANUFACTURE OR SALE OF ITEMS WITHOUT WRITTEN PERMISSION. COPYRIGHT © 1975 DIGITAL EQUIPMENT CORPORATION

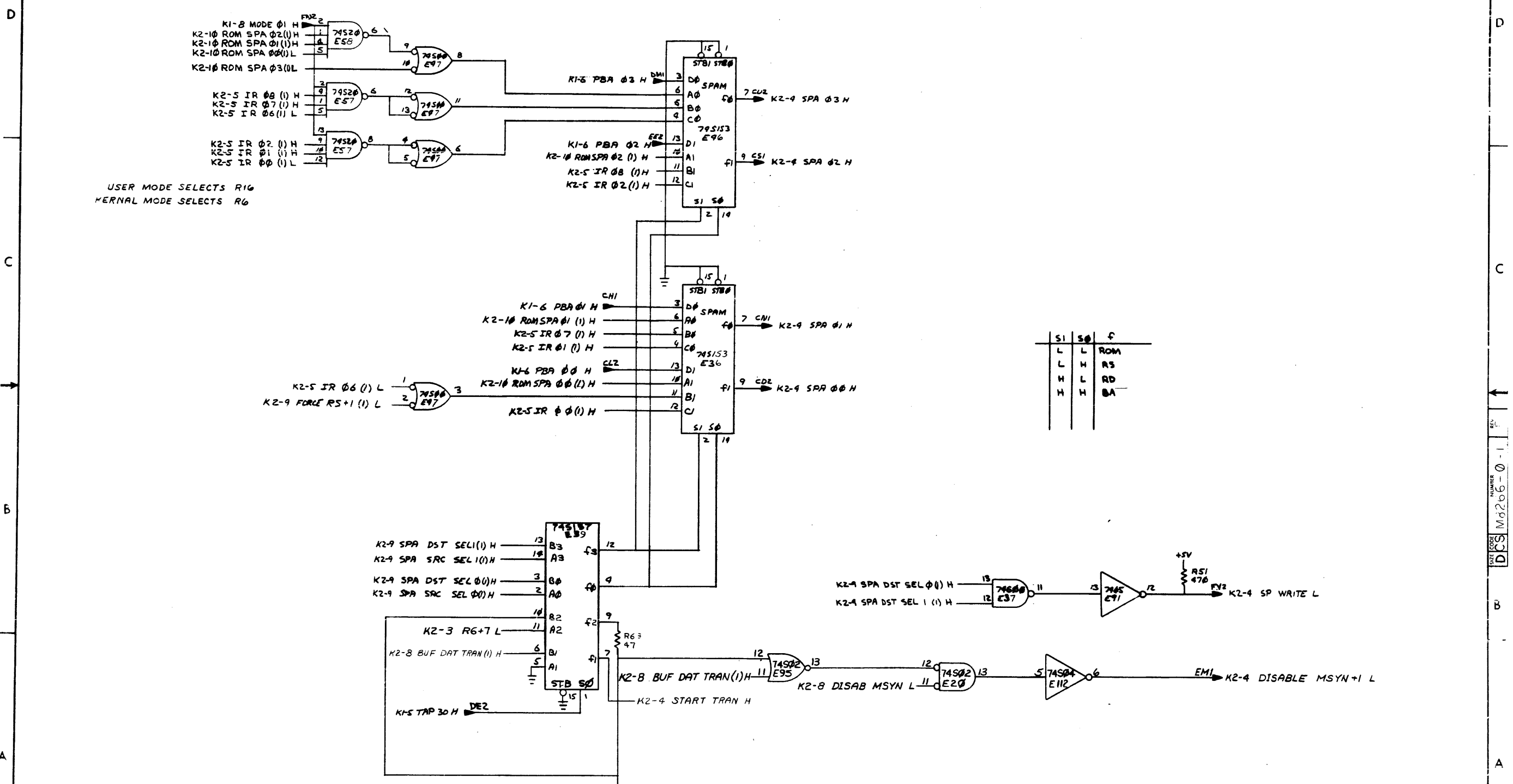

REVISIONS		
CHK	CHANGE NO.	REV

THIS DRAWING AND SPECIFICATIONS HEREIN ARE THE PROPERTY OF DIGITAL EQUIPMENT CORPORATION AND SHALL NOT BE REPRODUCED OR COPIED OR USED IN WHOLE OR IN PART AS THE BASIS FOR THE MANUFACTURE OR SALE OF ITEMS WITHOUT WRITTEN PERMISSION. COPYRIGHT © 1975 DIGITAL EQUIPMENT CORPORATION

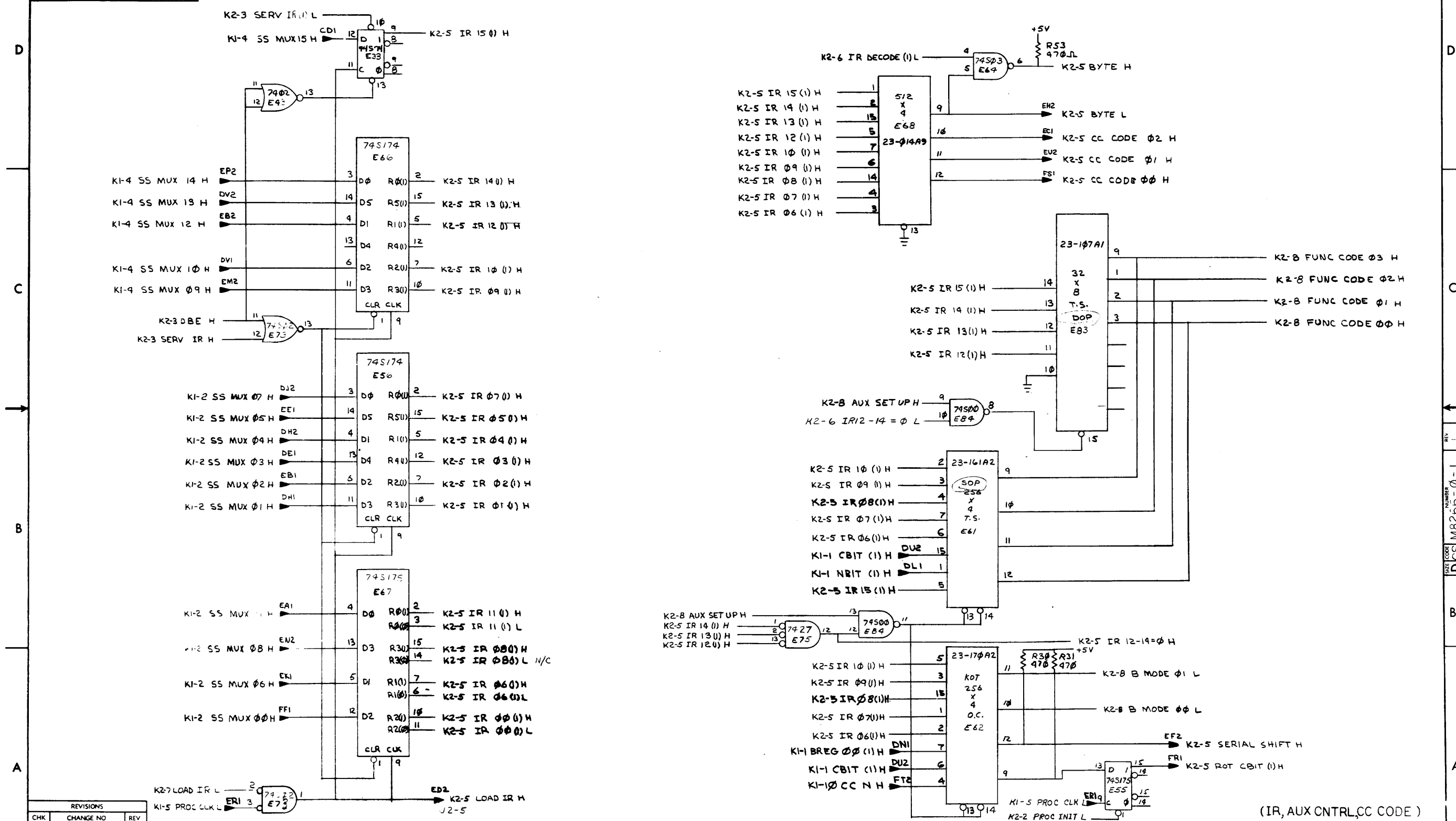

REVISIONS		
CHK	CHANGE NO	REV

TITLE	KDIIEA CONTROL (K2-5)	SIZE/CODE	DCS	NUMBER	M8266-0-1	REV.	
SCALE		SHEET	5	OF	10	DIST.	

THIS DRAWING AND SPECIFICATIONS HEREIN ARE THE PROPERTY OF DIGITAL EQUIPMENT CORPORATION AND SHALL NOT BE REPRODUCED OR COPIED OR USED IN WHOLE OR IN PART AS THE BASIS FOR THE MANUFACTURE OR SALE OF ITEMS WITHOUT WRITTEN PERMISSION. COPYRIGHT © 1973 DIGITAL EQUIPMENT CORPORATION

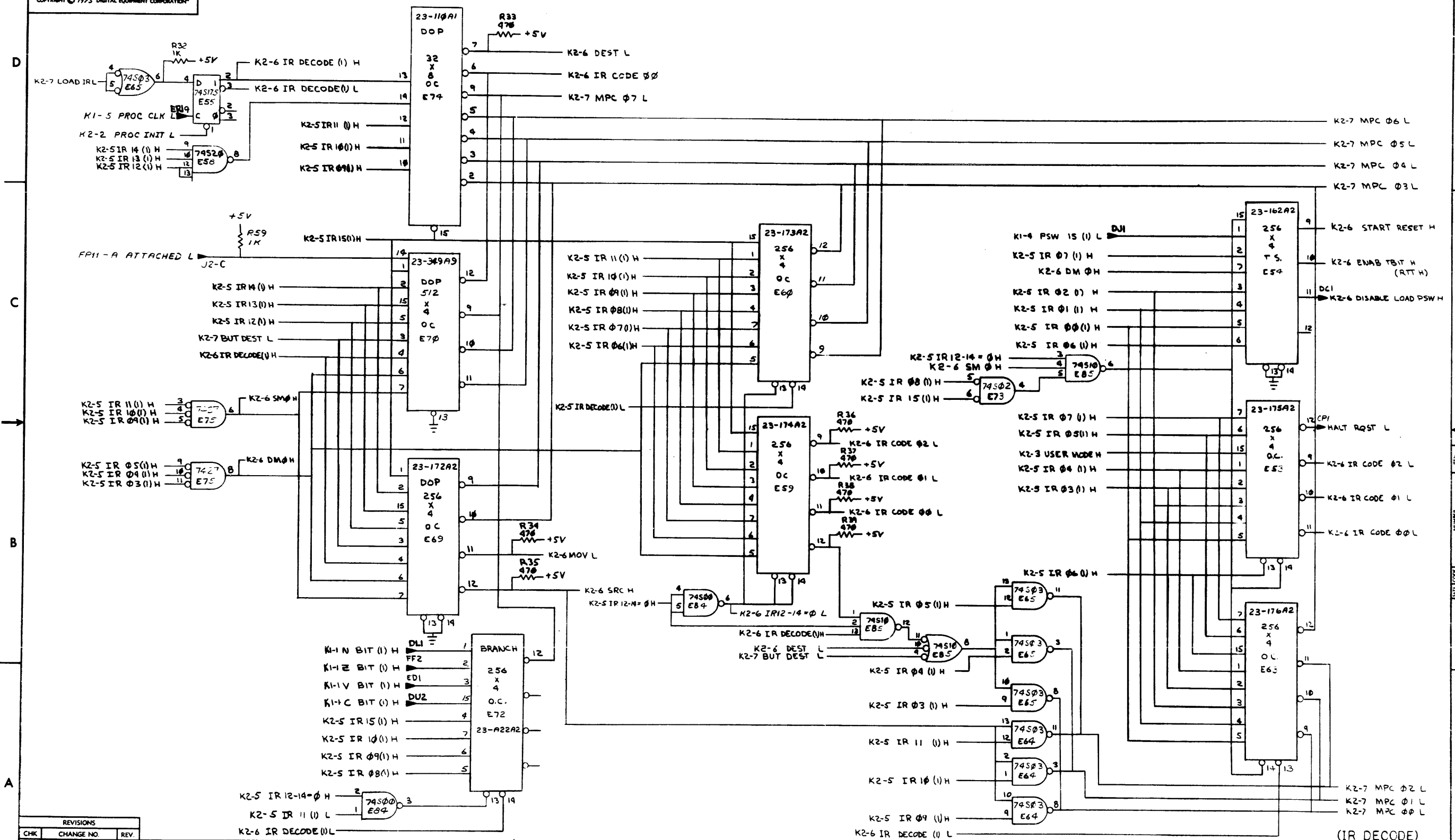

REVISIONS		
CHK	CHANGE NO.	REV.

"THIS DRAWING AND SPECIFICATIONS HEREIN ARE THE PROPERTY OF DIGITAL EQUIPMENT CORPORATION AND SHALL NOT BE REPRODUCED OR COPIED OR USED IN WHOLE OR IN PART AS THE BASIS FOR THE MANUFACTURE OR SALE OF ITEMS WITHOUT WRITTEN PERMISSION. COPYRIGHT © 1975 DIGITAL EQUIPMENT CORPORATION"

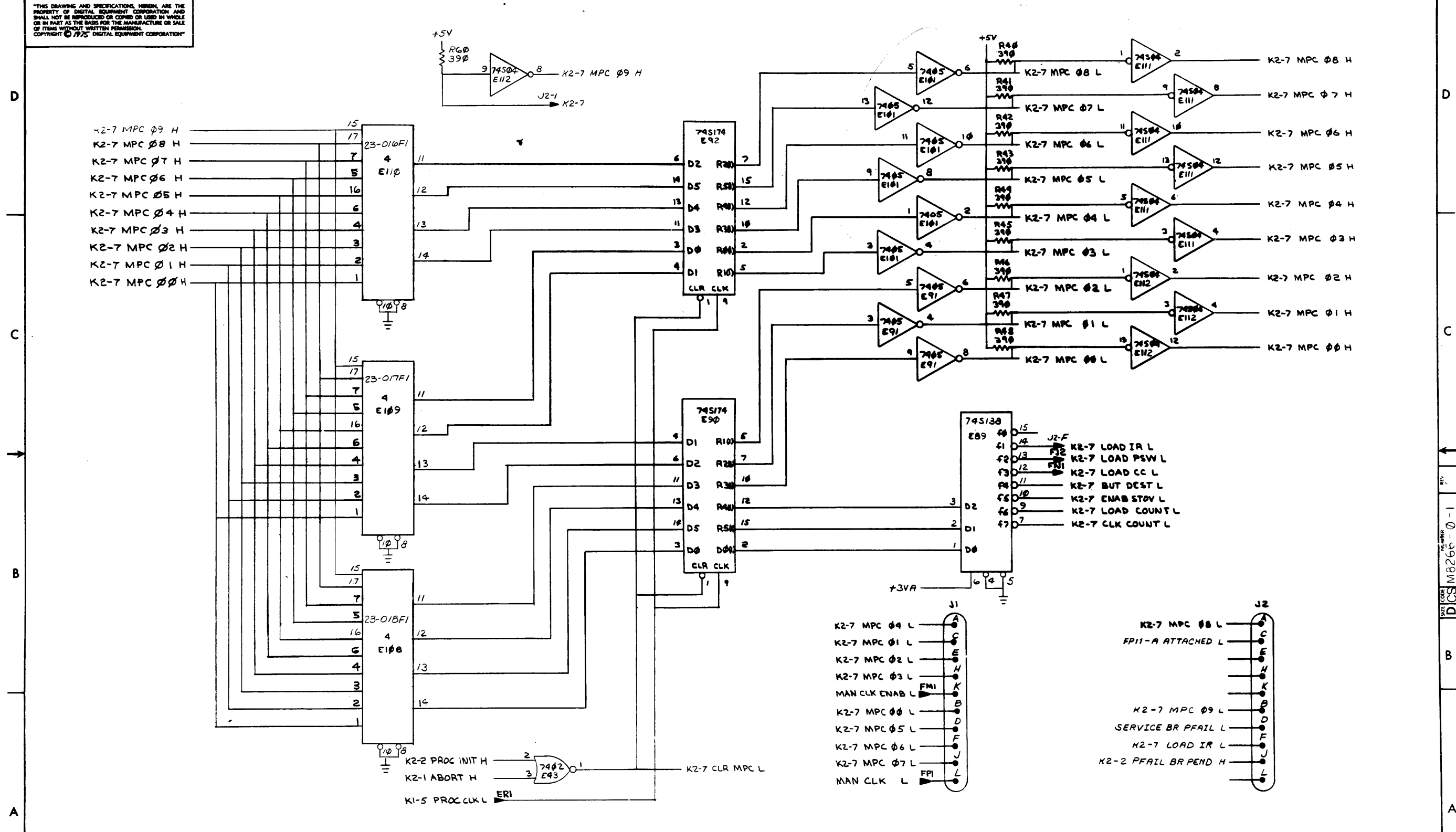

- K2-7 MPC φ4 L
- K2-7 MPC φ1 L
- K2-7 MPC φ2 L
- K2-7 MPC φ3 L
- MAN CLK ENAB L
- K2-7 MPC φ0 L
- K2-7 MPC φ5 L
- K2-7 MPC φ6 L
- K2-7 MPC φ7 L
- MAN CLK L

- K2-7 MPC φ8 L
- FP11-A ATTACHED L
- K2-7 MPC φ9 L
- SERVICE BR PFAIL L
- K2-7 LOAD IR L
- K2-2 PFAIL BR PEND H

REVISIONS		
CHK	CHANGE NO.	REV.

TITLE KDIII A CONTROL (K2-7)		SIZE CODE DCS	NUMBER M8266-0-1	REV.
SCALE	SHEET 7 OF 10	DIST.		

REV. 0-1 M8266-0-1 DCS

THE DRAWING AND SPECIFICATIONS HEREIN ARE THE PROPERTY OF DIGITAL EQUIPMENT CORPORATION AND SHALL NOT BE REPRODUCED OR COPIED IN WHOLE OR IN PART AS THE BASIS FOR THE MANUFACTURE OR SALE OF ITEMS UNLESS WRITTEN PERMISSION IS GRANTED BY DIGITAL EQUIPMENT CORPORATION.

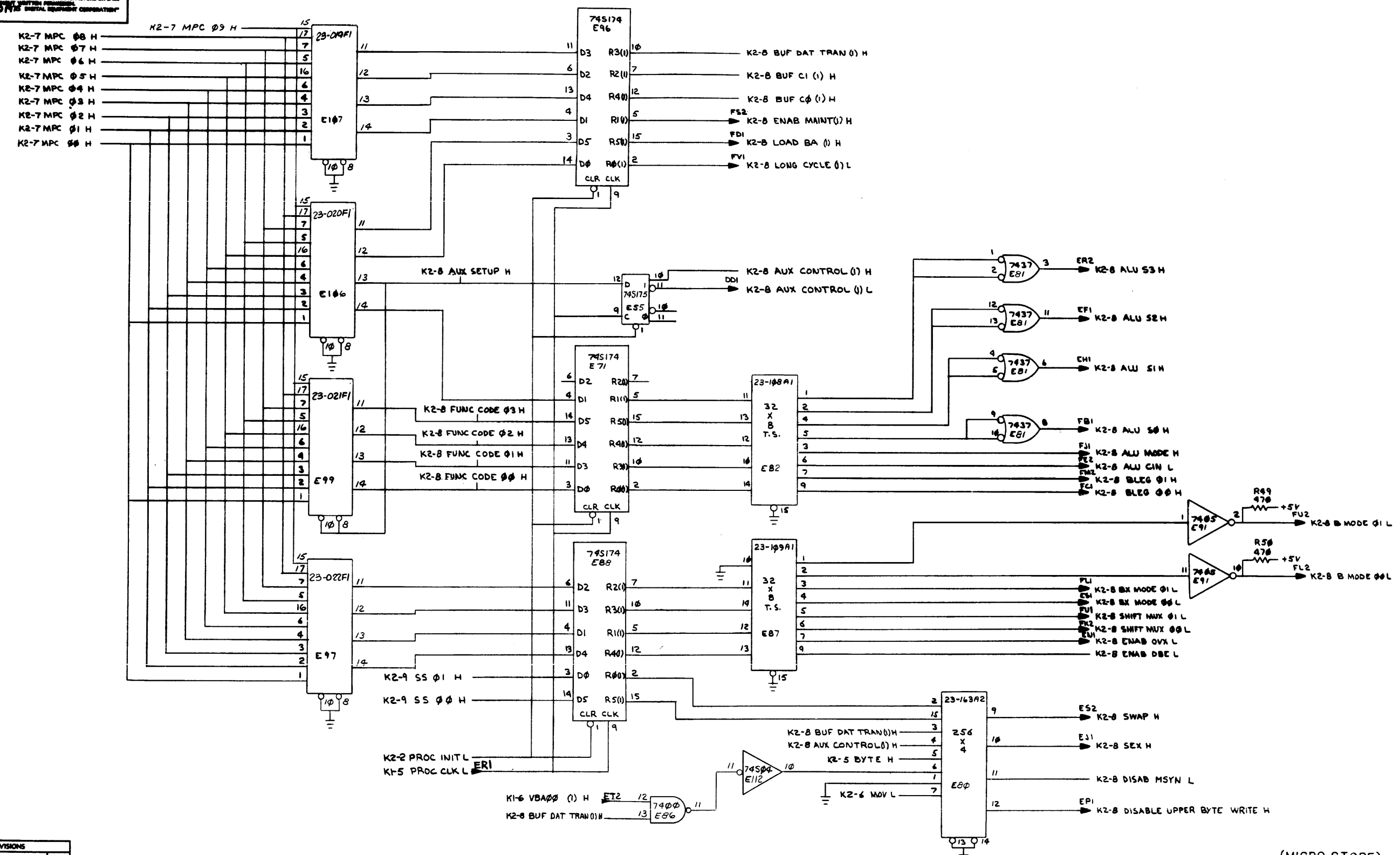

REVISIONS		
CHK	CHANGE NO.	REV.

TITLE	KDII-A CONTROL (K2-8)	SIZE	CODE	NUMBER	REV.
SCALE		SHEET	8	OF 10	D
DISTRIBUTION		D C S M8266-0-1			

(MICRO STORE)

REV. 1
M8266-0-1
D C S

THE SYMBOLS AND SPECIFICATIONS HEREIN ARE THE PROPERTY OF GENERAL ELECTRIC CORPORATION AND SHALL NOT BE REPRODUCED OR COPIED OR USED IN WHOLE OR IN PART AS THE BASIS FOR THE MANUFACTURE OR SALE OF ITEMS WITHOUT WRITTEN PERMISSION. COPYRIGHT © 1975 GENERAL ELECTRIC CORPORATION

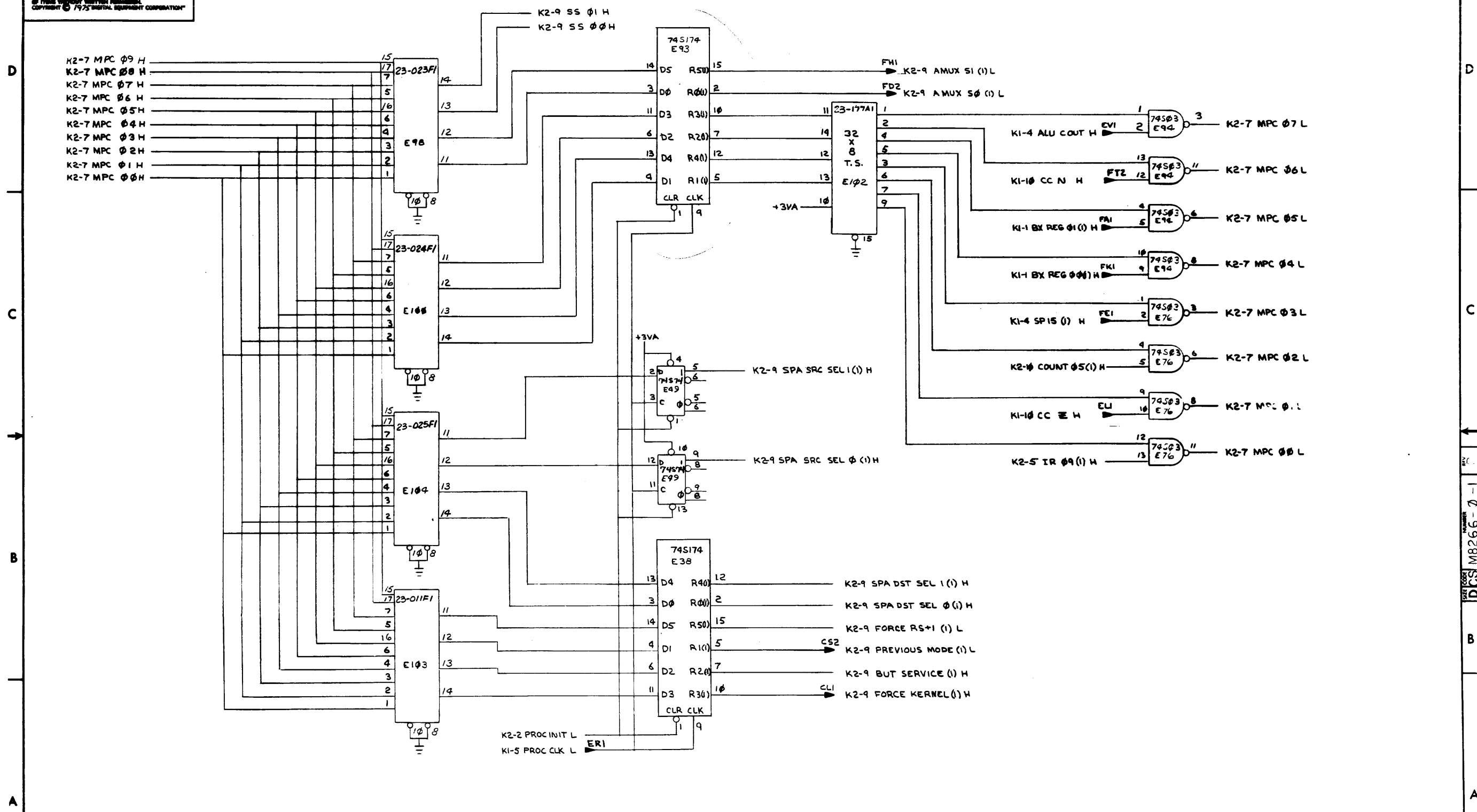

REVISIONS		
CHK	CHANGE NO.	REV.

TITLE		SIZE CODE	NUMBER	REV.
KDIIEA CONTROL (K2-9)		DCS	M8266-0-1	
SCALE	SHEET	DIST.		
	9 OF 10			

DCS M8266-0-1

"THIS DRAWING AND SPECIFICATIONS HEREIN ARE THE PROPERTY OF DIGITAL EQUIPMENT CORPORATION AND SHALL NOT BE REPRODUCED OR COPIED OR USED IN WHOLE OR IN PART AS THE BASIS FOR THE MANUFACTURE OR SALE OF ITEMS WITHOUT WRITTEN PERMISSION. COPYRIGHT © 1972 DIGITAL EQUIPMENT CORPORATION"

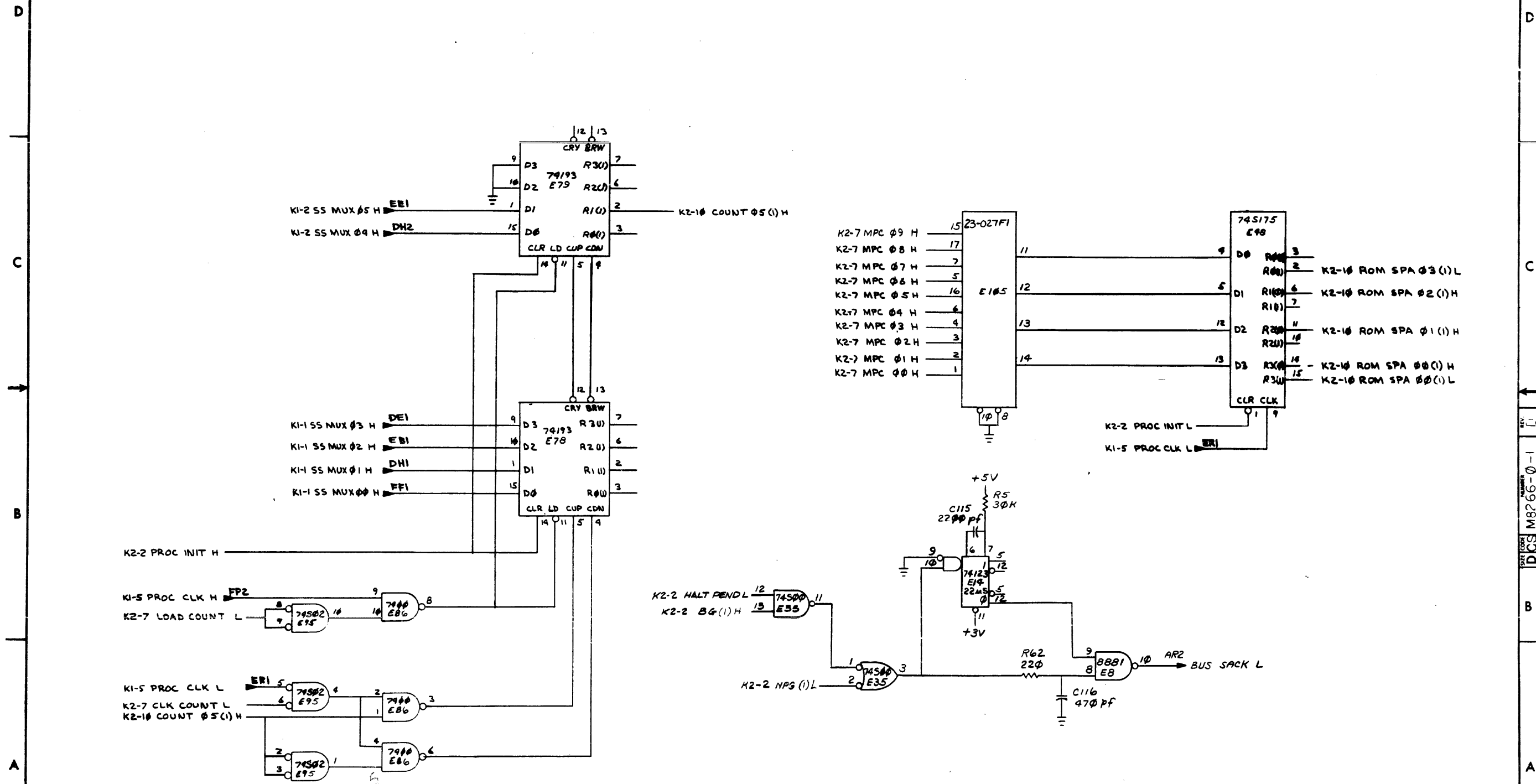

REVISIONS		
CHK	CHANGE NO.	REV.

DWG FORM NO. 000 130

TITLE		NUMBER		REV.
KDI1EA CONTROL (K2-10)		M8266-0-1		D
SCALE	SHEET	10 OF 10	DWT.	

(ROM SPA COUNTER)

REV. 1
D CS M8266-0-1