

**KY11-LB programmer's
console/interface module
operation and maintenance
manual**

Copyright © 1977 by Digital Equipment Corporation

The material in this manual is for informational purposes and is subject to change without notice.

Digital Equipment Corporation assumes no responsibility for any errors which may appear in this manual.

Printed in U.S.A.

This document was set on DIGITAL's DECset-8000 computerized typesetting system.

The following are trademarks of Digital Equipment Corporation, Maynard, Massachusetts:

DEC	DECtape	PDP
DECCOMM	DECUS	RSTS
DECsystem-10	DIGITAL	TYPESET-8
DECSYSTEM-20	MASSBUS	TYPESET-11
		UNIBUS

CONTENTS

	Page	
CHAPTER 1	OPERATING CHARACTERISTICS	
1.1	INTRODUCTION	1-1
1.2	GENERAL DESCRIPTION	1-1
1.3	FUNCTIONAL DESCRIPTION	1-3
1.4	SPECIFICATIONS	1-3
1.4.1	M7859 Interface Module Performance Specifications	1-3
1.4.2	Electrical Specifications	1-4
1.4.3	Mechanical Specifications	1-4
1.4.4	Environmental Specifications	1-4
CHAPTER 2	FUNCTIONAL DESCRIPTION	
2.1	INTRODUCTION	2-1
2.2	PROGRAMMER'S CONSOLE KEYPAD FUNCTIONS/ CONTROLS AND INDICATORS	2-1
2.2.1	Console Mode	2-1
2.2.2	Maintenance Mode	2-6
2.3	HARDWARE ORGANIZATION	2-6
2.4	MICROPROCESSOR INSTRUCTION SET	2-10
CHAPTER 3	INTERFACE MODULE	
3.1	MICROPROCESSOR	3-1
3.1.1	General Organization	3-1
3.1.2	State Control	3-2
3.1.3	Microprocessor Timing	3-2
3.1.4	Transition State Diagram	3-3
3.1.5	System Start-Up	3-4
3.2	INTERFACE MODULE REGISTERS AND CONTROLS	3-4
3.2.1	Address Register	3-4
3.2.2	Bus Address Register	3-4
3.2.3	Switch Register	3-4
3.2.4	Data Bus Control	3-4
3.2.5	Unibus Control	3-4
CHAPTER 4	MICROPROCESSOR INSTRUCTION DESCRIPTION	
4.1	DATA AND INSTRUCTION FORMATS	4-1
4.2	MICROPROCESSOR INSTRUCTIONS	4-2
4.2.1	Index Register Instructions	4-2
4.2.2	Accumulator Group Instructions	4-2
4.2.3	Program Counter and Stack Control Instructions	4-4
4.2.4	Input/Output Instructions	4-5
4.2.5	Machine Instruction	4-5

CONTENTS (Cont)

	Page
CHAPTER 5	INTERFACE MODULE DETAILED LOGIC DESCRIPTION
5.1	INTRODUCTION 5-1
5.2	PROGRAMMER'S CONSOLE KEYPAD FUNCTION SEQUENCES 5-3
5.2.1	Console Mode Key Functions 5-3
5.2.2	Maintenance Mode Key Functions 5-5
5.3	DETAILED LOGIC DESCRIPTION 5-5
5.3.1	Clock Circuitry 5-5
5.3.2	Power-Up Logic/Interrupt 5-5
5.3.3	Microprocessor 5-6
5.3.4	Timing State Decoder 5-6
5.3.5	Address Register 5-6
5.3.6	ROM 5-7
5.3.7	RAM 5-7
5.3.8	Switch Register 5-7
5.3.9	Switch Register Address Decode Logic 5-7
5.3.10	Bus Address Register 5-8
5.3.11	Data Bus Control Logic 5-8
5.3.12	Unibus Control 5-10
5.3.13	Keypad Scan Logic 5-10
5.3.14	Indicator Logic 5-11
5.3.15	Halt Logic 5-11
5.3.16	Buffers 5-11
5.3.16.1	Tristate Buffers (8093) 5-11
5.3.16.2	Tristate Transceivers (8833) 5-11
CHAPTER 6	CONSOLE MODE OPERATION
6.1	INTRODUCTION 6-1
6.2	CONSOLE KEY OPERATIONS 6-1
6.3	NOTES ON OPERATION 6-5
6.4	EXAMPLES OF CONSOLE SEQUENCES 6-6
CHAPTER 7	MAINTENANCE MODE OPERATION
7.1	INTRODUCTION 7-1
7.2	MAINTENANCE MODE KEY OPERATIONS 7-1
7.3	NOTES ON OPERATION 7-2
CHAPTER 8	KY11-LB MAINTENANCE
8.1	PRELIMINARY CONSIDERATIONS 8-1
8.2	M7859 FAILURES 8-2

CONTENTS (Cont)

		Page
CHAPTER 9	KY11-LB INSTALLATION	
9.1	KY11-LB DESCRIPTION	9-1
9.2	CPU BOX TYPE	9-1
9.3	CPU DIFFERENCES	9-1
9.4	BA11-L 13.3 CM (5-1/4 INCH BOX) INSTALLATION	9-1
9.5	BA11-K 26.7 CM (10-1/2 INCH BOX) INSTALLATION	9-3
9.6	MAINTENANCE MODE HOOK-UP	9-6
APPENDIX A	KY11-LB MICRO-CODE LISTINGS	
APPENDIX B	IC DESCRIPTIONS	

FIGURES

Figure No.	Title	Page
1-1	Programmer's Console/Interface – PDP-11/04/34 Configuration	1-1
1-2	Interface Module (M7859)	1-2
2-1	KY11-LB Logical Organization	2-2
2-2	KY11-LB Keypad	2-3
2-3	Interface Module Detailed Block Diagram	2-7
3-1	Microprocessor Signal Interface	3-1
3-2	Timing Diagram – Microprocessor Instruction	3-2
3-3	Transition State Diagram	3-3
5-1	RAM Address Allocations	5-1
5-2	Keypad Image	5-2
8-1	Clock Waveforms	8-2
9-1	M7263	9-2
9-2	M7266	9-2
9-3	Cables	9-3
9-4	BA11-L	9-4
9-5	BA11-K	9-5

TABLES

Table No.	Title	Page
2-1	KY11-LB Controls and Indicators	2-3
3-1	State Control Coding	3-2
3-2	Cycle Coding	3-3
5-1	RAM Function Address Assignments	5-2

KY11-LB PROGRAMMER'S CONSOLE/INTERFACE MODULE OPERATION

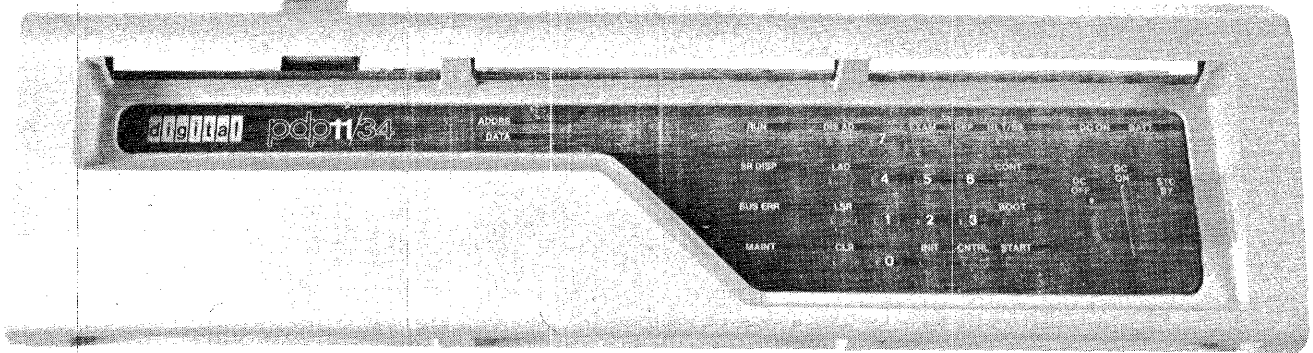
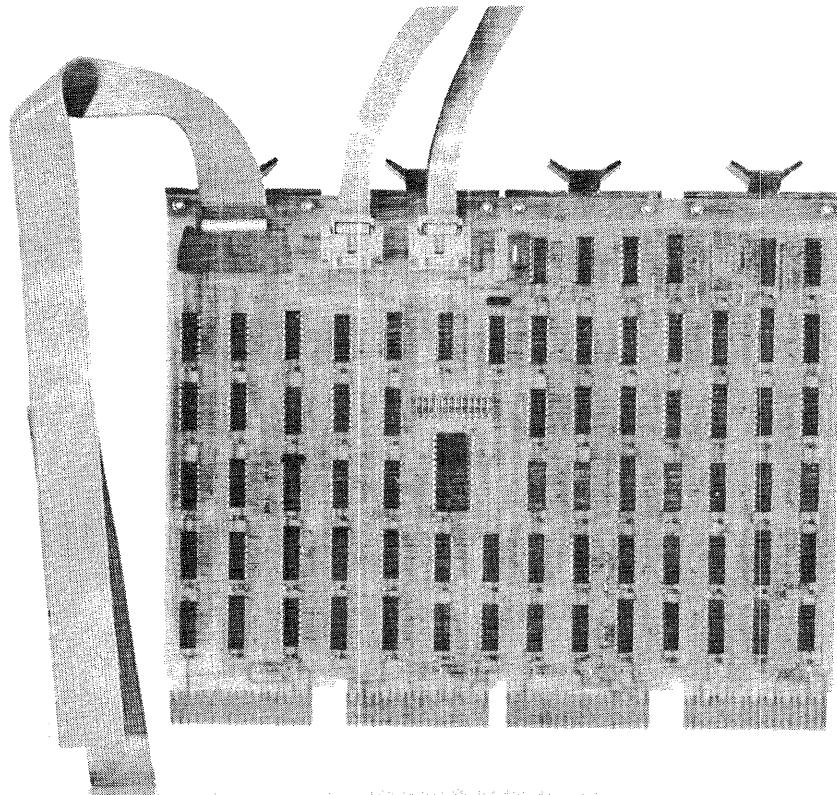

PREFACE

The *KY11-LB Programmer's Console/Interface Module Operation and Maintenance Manual* provides the information required to operate this option in console or maintenance mode. The manual also presents a detailed theory of operation of the interface module hardware and software components, data on the utilization of the programmer's console as a maintenance tool for the PDP-11/04/34 processors, and information on the troubleshooting and maintenance of the interface module itself. The information is presented in nine chapters:

- | | |
|-----------|---|
| Chapter 1 | Provides an introduction, general description, and overview of electrical and mechanical specifications. |
| Chapter 2 | Presents a functional description of the console, operating modes, controls and indicators, and a general discussion of interface module hardware organization and software facilities. |
| Chapter 3 | Describes, on a detailed block diagram level, interface module functions, registers and controls, and the functions of the MOS/LSI microprocessor. |
| Chapter 4 | Describes the microprocessor instruction set. |
| Chapter 5 | Presents a description of the M7859 Interface module to the logic level. |
| Chapter 6 | Provides operating information on console utilization in console mode. |
| Chapter 7 | Contains procedures for using the console in maintenance mode (maintenance of PDP-11/04/34 processor). |
| Chapter 8 | Covers some maintenance techniques for the KY11-LB interface module. |
| Chapter 9 | Describes installation procedures for various options. |

NOTES

In the material presented in this manual, the term "processor" refers to the KD11-D, KD11-E, and KD11-EA PDP-11/04/34 processors.

If the operator is not familiar with console functions, Chapter 6 should be consulted.

CHAPTER 1 OPERATING CHARACTERISTICS

1.1 INTRODUCTION

The PDP-11/04/34 Programmer's Console and Interface module (KY11-LB) provides all the functions now offered with the PDP-11/05. The Programmer's console interfaces to the Unibus (Figure 1-1) through a quad SPC module. To use this option, the normally provided KY11-LA Programmer's Console must be removed and the KY11-LB Console installed in its place. The KY11-LB Console contains a 7-segment LED display and a 20-key keypad for generating the console commands. Several indicators are also provided for additional convenience in monitoring system status.

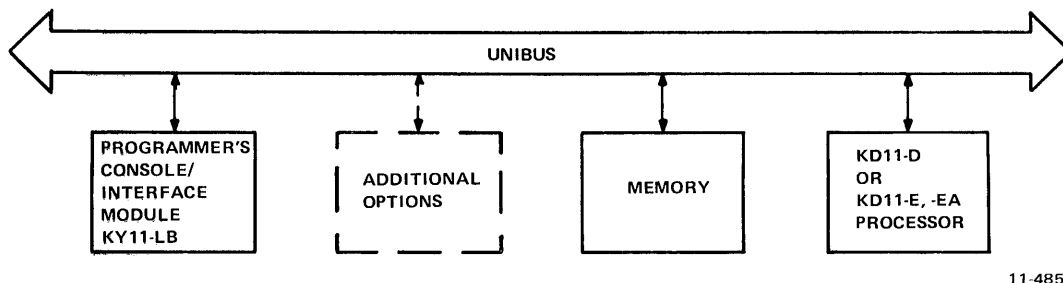

11-4855

Figure 1-1 Programmer's Console/Interface - PDP-11/04/34 Configuration

The KY11-LB Programmer's Console/Interface module comprises an INTEL 8008 single-chip, large scale integration (LSI) microprocessor and associated registers, Unibus control logic, and auxiliary memory. The unit is also provided with a 20-key keypad for operator/programmer interaction with the KD11-D, -E, -EA via the interface module, six indicator LEDs, a 6-digit, 7-segment display for address or data, and a dc power switch. The microprocessor communicates with a read-only memory (ROM) which contains a number of fixed routines for use during normal console and maintenance operation.

1.2 GENERAL DESCRIPTION

The M7859 Interface module (Figure 1-2) functions as the interface between the programmer's console and the KD11-D, KD11-E, or KD11-EA processor, via the Unibus. The unit consists of solid state integrated circuits with TTL-compatible input and output lines. The heart of the interface module is a single-chip, large scale integration (LSI) microprocessor which executes designated keyboard functions via programs stored in ROM memory. Auxiliary logic functions including clock, decoding and timing circuitry, and addressing and Unibus drivers/receivers comprise the remaining logic of the board.

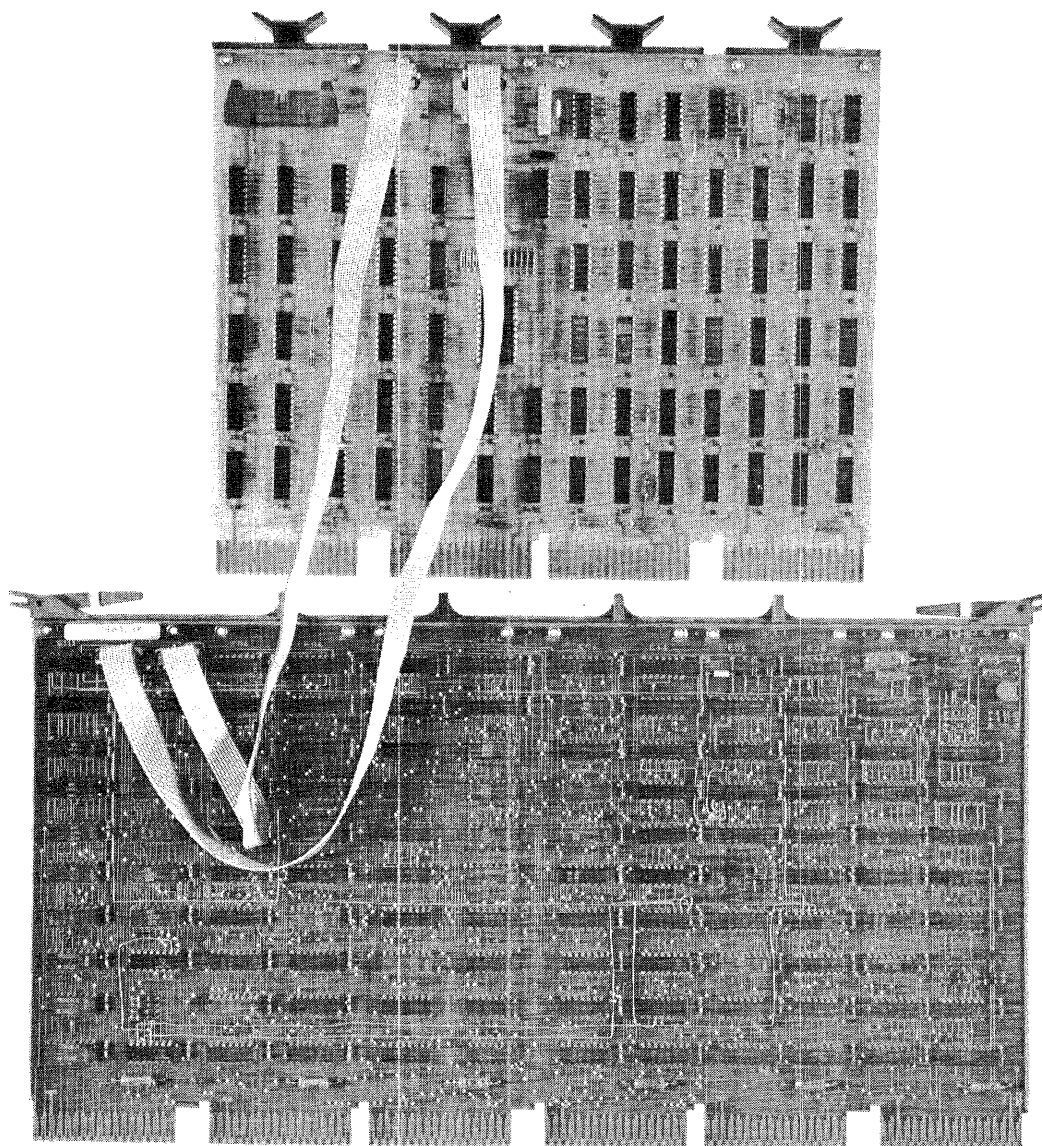

8141-14

Figure 1-2 Interface Module (M7859)

The microprocessor chip is an 8-bit, parallel control element packaged as a single metal oxide silicon circuit in an 18-pin, dual in-line package. With the addition of external clock driving circuitry and decoding elements, plus memory and data bus control, the unit is capable of performing as a powerful, general-purpose, central processing unit. Internal logic of the microprocessor chip is structured around an 8-bit internal data bus and includes instruction decoding, memory control, accumulator and scratchpad memory, arithmetic and logical capability, program stack, and condition code indicators. Data transfer between the microprocessor chip and the remaining logic functions of the interface module is accomplished through an 8-bit, bidirectional data port which is an integral part of the microprocessor. An internal stack (scratchpad memory) contains a 14-bit program counter (PC) and an additional complement of seven 14-bit registers for nesting up to seven levels of subroutines. The 14-bit addressing capacity allows the microprocessor to access up to 16K memory locations which may comprise any mix of ROM or RAM.

1.3 FUNCTIONAL DESCRIPTION

The KY11-LB Programmer's Console permits the implementation of a variety of functions through a 20-key keypad located on the front panel of the programmer's console. Keypad functions are divided into two distinct modes: console mode and maintenance mode. In console mode operation, a number of facilities exist for displaying addresses and data, for depositing data in and examining the content of Unibus addresses including processor registers for entering data into a temporary buffer for use as address or data, and for single instruction stepping the processor. The latter feature is especially useful during program debugging functions.

Normal console keyboard functions are not available during maintenance mode. This mode permits sampling and display of the Unibus address lines and Unibus data lines, and may allow the console to take control of the Unibus to examine and deposit Unibus addresses if a processor is not present in the system or is malfunctioning. Additionally, the maintenance function permits assertion of the manual clock enable and display of the current processor microprogram counter (MPC). Single-clock cycling of the MPC is also possible to facilitate step by step checkout of processor op codes and control logic during maintenance functions. In conjunction with this function, assertion of manual clock enable permits the processor to be stepped through its power-up routine. The manual clock enable may be dropped via the START key at any time with a resulting display of the current MPC. Exit from maintenance mode to console mode may be accomplished at any time by depressing the CLR key on the keypad.

1.4 SPECIFICATIONS

1.4.1 M7859 Interface Module Performance Specifications

Operating Speed at 500 kHz

Two-Phase Clock Period	2 μ s
Time State (SYNC)	4 μ s
Instruction Time (Microprocessor)	12-44 μ s

Word Size

Data	8-bit word
Instruction	1, 2, or 3 8-bit words
Address	14 bits

Memory Size

ROM	4 512 \times 4 organized as 1024 8-bit words
RAM	16 words by 8 bits

Input/Output Lines	
Memory Data	16 bits
Address	18 bits
Control (Address)	2 bits
Unibus Control	5 bits
Microprocessor Instruction Repertoire	
48 Basic Instructions	
Instruction Categories	Register Operation
	Accumulator
	PC and Stack Control
	I/O
	Machine

1.4.2 Electrical Specifications

Power Supply	+5 V at 3.0 A -15 V at 60 mA
Input Logic Levels (all modules)	
TTL Logic Low	0.0 to 0.8 Vdc
TTL Logic High	2.0 to 3.6 Vdc
Output Logic Levels (all modules)	
TTL Logic Low	0.0 to 0.4 Vdc
TTL Logic High	2.4 to 3.6 Vdc
Power Consumption	
Interface Module	14 W
Monitor/Control Panel	1 W

1.4.3 Mechanical Specifications

M7859 Interface Module	
Board Type	Quad SPC
Dimensions	
Height	21.44 cm (8.44 in)
Length	26.08 cm (10.44 in)
Programmer's Console (Overall Panel Dimensions)	
Width	47.63 cm (18.75 in)
Height	13.02 cm (5.125 in)
Depth	6.76 cm (2.66 in)

1.4.4 Environmental Specifications

Ambient Operating Temperature	5° to 50° C (41° to 122° F)
Humidity	10% to 95% maximum, wet bulb 32° C (90° F)

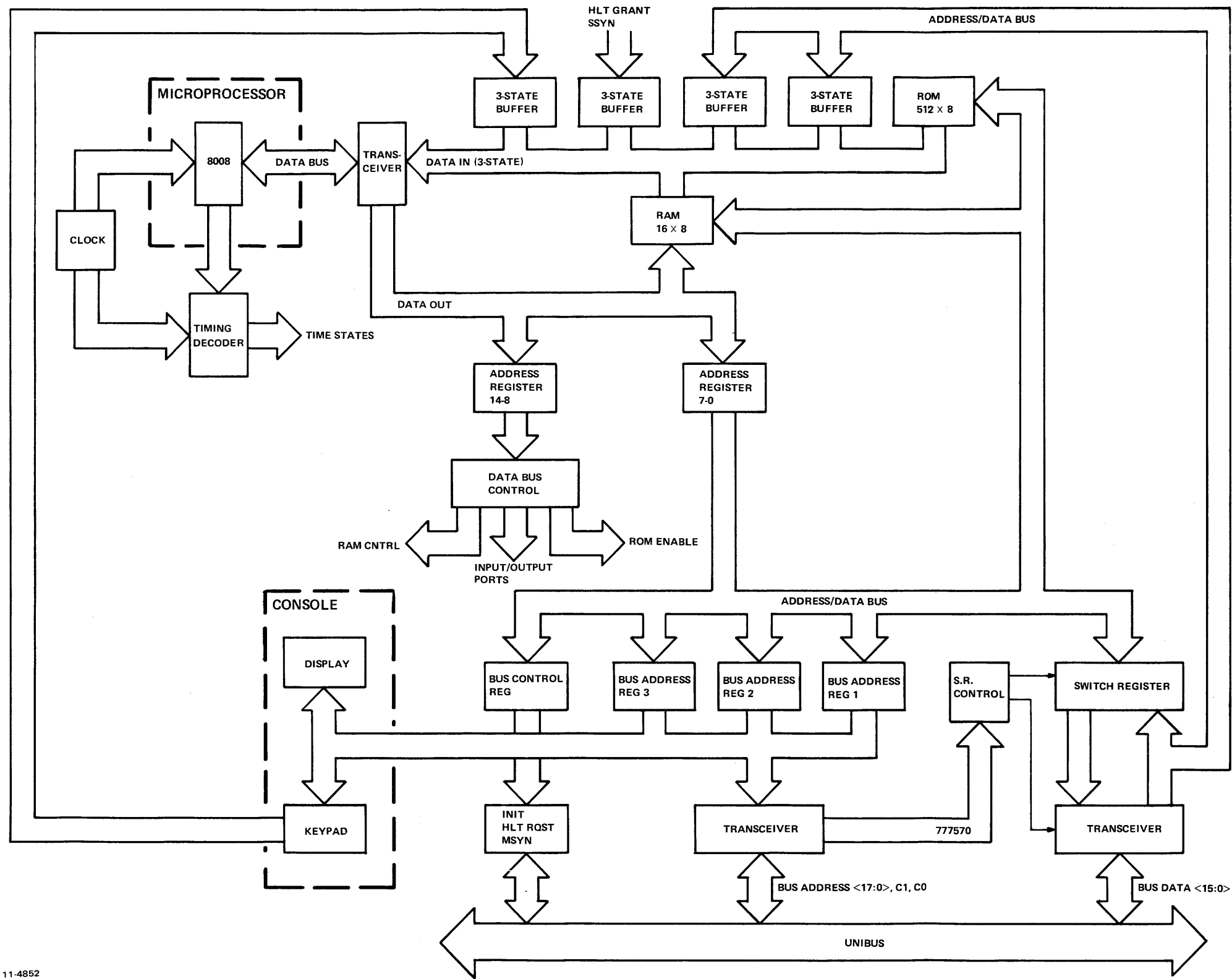

11-4852

Figure 2-1 KY11-LB Logical Organization

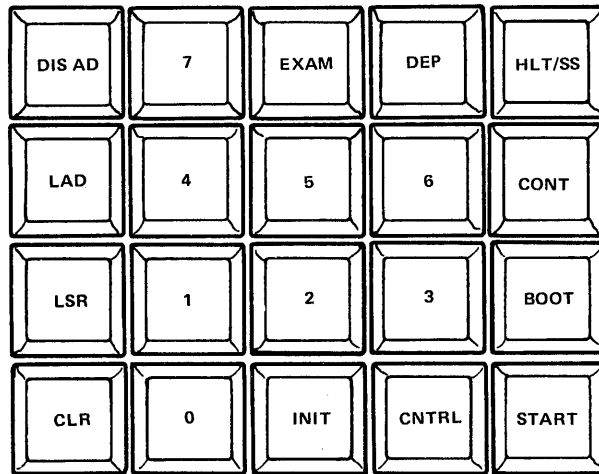

11-4846

Figure 2-2 KY11-LB Keypad

Table 2-1 KY11-LB Controls and Indicators

Control/Indicator	Function
Keyboard - Console Mode	
LAD	Load Address - Moves the 18-bit number in the temporary register into the Unibus address pointer. The temporary register is then cleared and displayed.
LSR	Load Switch Register - Moves the 16 lower bits of the temporary register to a register which can be read via Unibus address 777570. The switch register contents will be displayed.
DEP	Deposit - Causes the console to do a DATO on the bus address pointed to, using the data in the temporary register (two MSBs are truncated). Sequential deposits cause the address pointer to be incremented. This key is operative only if the processor is halted.
0-7	Numerics - These keys are used to enter data into a temporary data buffer prior to use as either address or data. Use of a numeric key forces the console to display the data held in the temporary buffer. A 6-digit number is generated as octal digits are entered from the right and left shifted.
CNTRL	Control - This key is used only in conjunction with other keys either to prevent accidental operation of certain functions or to provide entry into maintenance mode or other features. When used, the CNTRL key must be pressed first and held down while the second key is pressed. Those keys which are interlocked with the CNTRL key are indicated by "CNTRL-second key" (e.g., CNTRL-START).

Table 2-1 KY11-LB Controls and Indicators (Cont)

Control/Indicator	Function
CNTRL-INIT	Initialize – Operative only if the processor is halted. Causes BUS INIT L to be generated for 150 ms.
DIS AD	Display Address – This key causes the current Unibus address pointer to be displayed. The next examine or deposit will occur at the address displayed.
EXAM	Examine – Causes the console to do a DATI on the bus address pointed to and stores the data in the temporary register which is then displayed. Sequential examines cause the address pointer to be incremented by 2 or by 1 if the address is in the range 777700–777717. This key is operative only if the processor is halted.
CLR	Clear Entry – Clears the current contents of the temporary register which is then displayed.
CNTRL-BOOT	Causes M9301 bootstrap terminator to be activated if present in the system. Console will boot only if the processor is halted.
CNRL-HALT/SS	Halt/Single Step – Halts the processor if the processor is running. If the processor is already halted it will single-instruction step the processor. It also retrieves and displays the contents of R7 (program counter). The CNTRL key is not required to Single-Instruction Step the machine.
CNTRL-CONT	Continue – Allows processor to continue using its current program counter from a halted state. The contents of the switch register are displayed.
CNTRL-START	Operative only if halted, this causes the program counter (R7) to be loaded with the contents of the Unibus address pointer. BUS INIT L is then generated and the processor is allowed to run. Switch register contents are then displayed.
CNTRL-7	Causes the Unibus address pointer to be added to the temporary data buffer which is also incremented by 2. This allows the console to calculate the correct offset address when mode 6 or 7, register 7 PIC (Position Independent Code) instructions are encountered.
CNTRL-6	This causes the switch register to be added to the temporary data buffer. This is useful when mode 6 or 7 instructions are encountered not using R7.
CNTRL-1	Maintenance Mode – This combination puts the console into maintenance mode with certain maintenance features available. When the console is in maintenance mode, the normal console mode keypad functions are not available. The CLR key causes the console to exit from maintenance mode into console mode via a processor halt.

Table 2-1 KY11-LB Controls and Indicators (Cont)

Control/Indicator	Function
SR DISP	Indicates that the content of the switch register is being displayed.
MAINT	Indicates that console is in maintenance mode.
BUS ERR	Indicates that an examine or deposit resulted in a SSYN time-out or that HALT REQUEST failed to receive a HALT GRANT.
DC Power Switch	
DC OFF	All dc power to logic is off.
DC ON	All dc power to logic is on.
STNBY	DC power is provided to MOS memory only.*

*Available in all BA11-C machines. Available in BA11-K boxes which have Battery Backup Option only.

Table 2-1 refers to certain registers which are located in the scratchpad RAM. These include the following:

1. Display Data
2. Keypad Image
3. Temporary Data Buffer
4. Unibus Address Pointer
5. Switch Register Image
6. EXAM, DEP, ENB and C1 flags

Detailed discussion of the scratchpad RAM and its registers is set forth in Chapter 5.

2.2.2 Maintenance Mode

Maintenance mode is entered by pressing the CNTRL key and the 1 key simultaneously. Note that the functions performed by the appropriate keys are quite different from console mode. This mode offers the ability to assert the manual clock enable and thus to single-clock cycle the processor while monitoring the contents of the processor microprogram counter.

2.3 HARDWARE ORGANIZATION

A detailed block diagram of the interface module showing data flow and control is indicated in Figure 2-3. The control functions shown include those for the Unibus interface and the internal data bus with the microprocessor. The latter controls include those for reading from and writing into the RAM, enabling ROMs 1 and 2, and reading the Unibus temporary buffer register or loading the bus address and switch registers. All of these functions occur on appropriate control from the stored program and keypad.

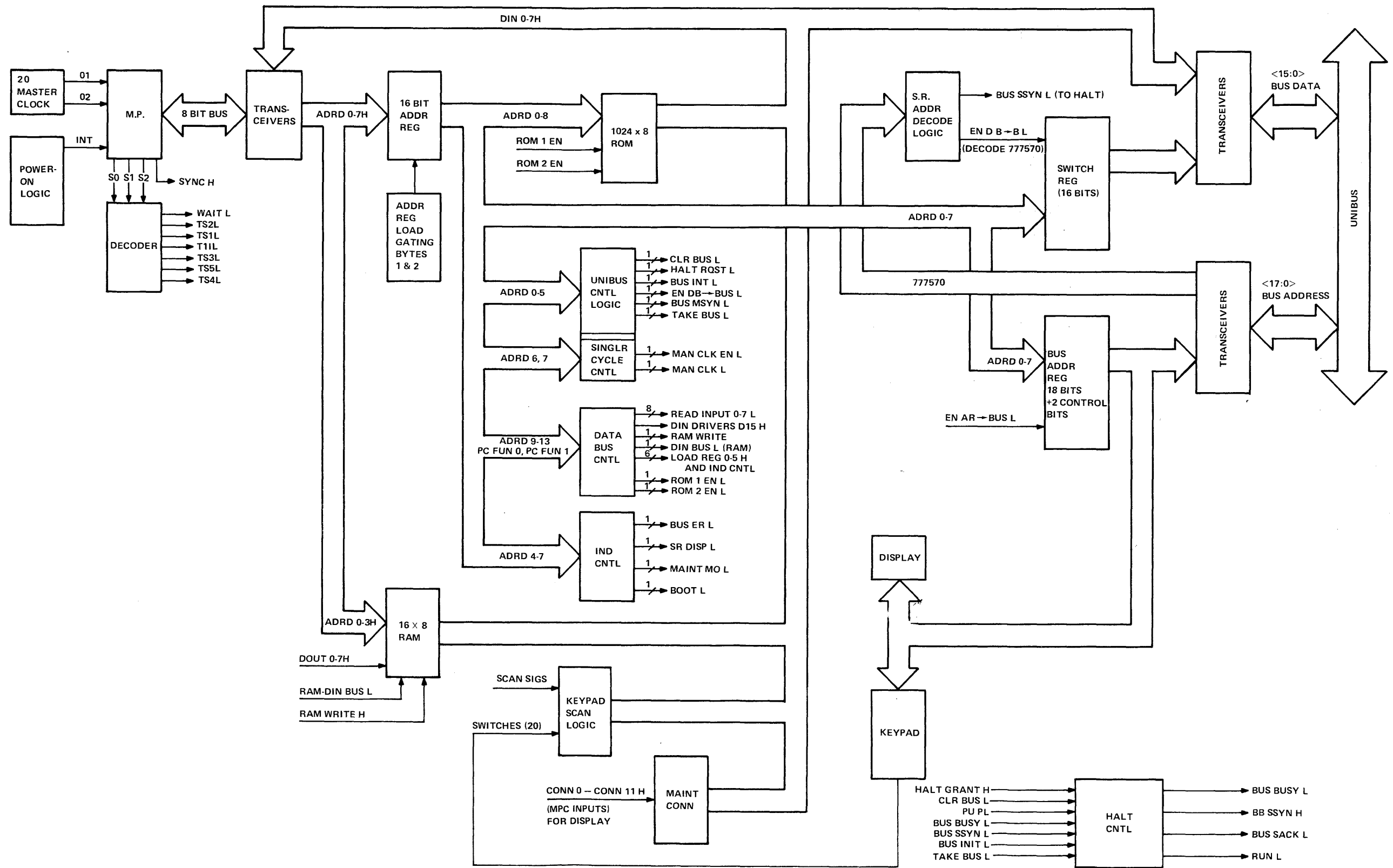

Figure 2-3 Interface Module Detailed Block Diagram

Decoder for Timing States

The decoder element receives the state outputs S0, S1, and S2 from the microprocessor and generates the time states for the operation of the interface module. A sync pulse corresponding to two phase clock periods (1 time state) is also provided by the microprocessor.

Power-up Logic

This circuitry activates the microprocessor, clearing its various registers and generating a clear line to all the registers of the interface module. There are separate clears for the address register and all other registers.

Address Register

This 16-bit register is the principal buffer between the microprocessor and the remainder of the logic of the interface module. Although designated as an address register, the element also handles control data for the Unibus, data bus, and other control functions and outputs to the bus address and switch registers. One of its major functions is to receive the microprocessor program counter contents for fetching new instructions from the ROM or RAM.

RAM

The 16-word by 8-bit RAM gives the interface module a scratchpad memory which may be read or whose contents may be modified under program control.

ROM

The ROM, consisting of four 512×4 -bit ROMs, makes a total of 1024 8-bit bytes available for the stored programs which execute the console functions.

Switch Register Address Decoding

This logic decodes 777570, an 18-bit address defining the switch register and a DATI on the Unibus to cause the switch register to be enabled onto the Unibus.

Switch Register

This 16-bit buffer register handles the data word to the Unibus.

Bus Address Register

This 20-bit register buffers address information between the interface module and the Unibus. Eighteen bits are allocated for the actual address, and two control bits indicate the direction of data flow. Scan signals for the keypad and NUM lines for the display logic are specified by this register.

Tristate Gates

These units are used to gate buffered Unibus data (16 bits) and Unibus address (18 bits) lines onto the tristate data bus by asserting an appropriate read input line. Keypad outputs and those maintenance lines provided for display of the processor microprogram counter are similarly buffered and gated. The outputs are all wire ORed onto the internal data bus and applied as input to the tristate transceivers.

Keypad Scan and Display Logic

This circuitry develops read and drive signals for the keypad and LED display respectively. Five read signals developed from the scan signals are used to scan the keypad switch closures in groups of four. The drive signals are applied to the LED displays whose values are determined by the 3-bit NUM input.

Data Bus Control

This circuitry performs all internal interface module control functions including RAM control, ROM enable, and selection of input/output ports. The logic also determines system operation during instruction, data fetch, or data out (TS3) via a 32×8 -bit ROM.

Unibus Control

The Unibus control register supervises data transfers between the interface module and the Unibus. According to the input bit patterns to the register, data transfer from the interface module to the Unibus, halt request, bus master sync, and other functions may be generated as required for proper interfacing of the two elements. Two other signals generated in the Unibus control register permit single stepping of the processor clock.

Indicator Logic

This 4-bit register drives appropriate console indicators to show certain console states or errors. An indicator is turned on to show the existence of a bus error, when the switch register is being displayed or when in maintenance mode.

Halt Logic

This circuitry halts the processor under various conditions and performs handshaking functions when the console takes complete control of the bus. When a HALT from the console is detected by the processor, the processor recognizes it as an interrupt request. The processor then inhibits its clock and returns a recognition signal to the console causing the console to assert an acknowledge. The console now has complete control of the Unibus and processor and may maintain this condition, with the processor halted, as long as desired.

2.4 MICROPROCESSOR INSTRUCTION SET

The interface module microprocessor has a repertoire of 48 basic instructions. According to the instruction type, these may range from 1 to 3 bytes (8 to 24 bits) in length. The successive bytes of a given instruction must be located in sequential memory locations. Instructions fall into one of five categories:

- Index Register
- Accumulator (Arithmetic/Logical)
- Program Counter and Stack Control
- Input/Output
- Machine

A description of the microprocessor instructions and the number of time states required for their execution is given in Chapter 4.

CHAPTER 3 INTERFACE MODULE

3.1 MICROPROCESSOR

3.1.1 General Organization

The microprocessor sends and receives data over an 8-bit data and address bus (D_0 to D_7) and utilizes four input and four output lines (Figure 3-1). The microprocessor contains six 8-bit data registers, an 8-bit accumulator, two 8-bit temporary registers, four flag bits, and an 8-bit parallel binary arithmetic unit. The arithmetic element is capable of performing addition, subtraction, and logical operations. Additionally, a memory stack containing a 14-bit program counter and seven 14-bit words is used to store program and subroutine addresses. The microprocessor machine cycle usually requires five sequential states: TS1, TS2, TS3, TS4, and TS5. During time states TS1 and TS2, the external memory is addressed by a lower and an upper address byte respectively to form a 14-bit address. Also at TS1 time, the program counter (PC) is incremented for the next instruction fetch cycle. During time state TS3, the instruction addressed during states TS1 and TS2 is fetched and during the final two cycles, TS4 and TS5, it is executed. Figure 3-2 shows the possible number and sequence of the instruction states. Note that for this application of the microprocessor, the interrupt function is utilized only during the power-on sequence.

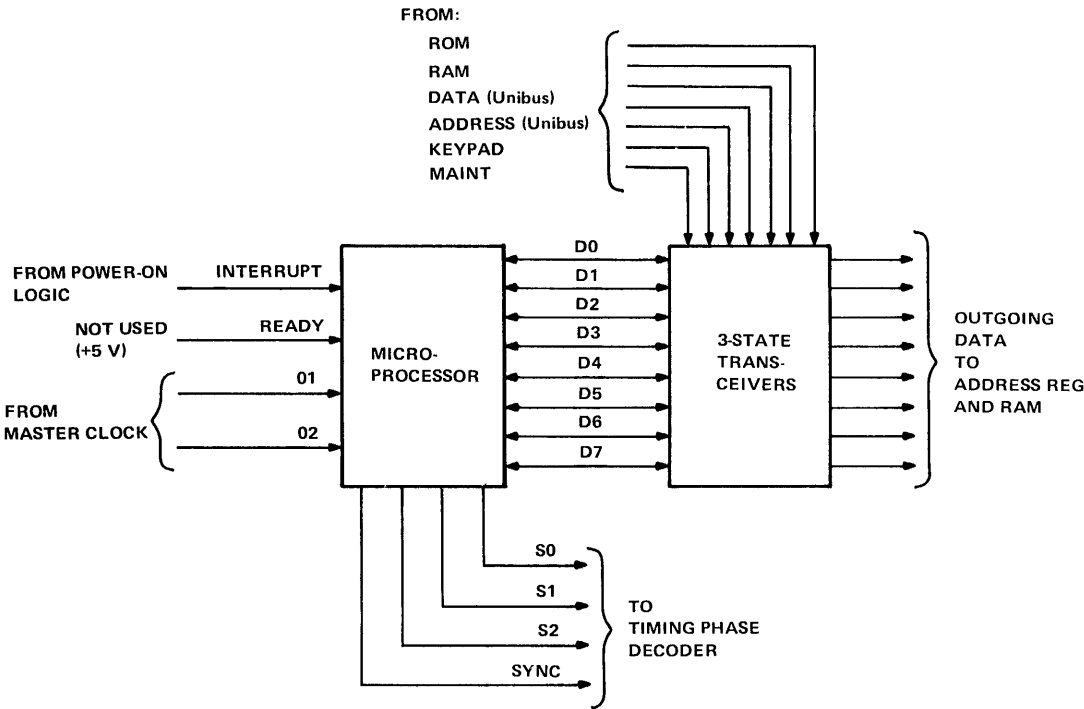
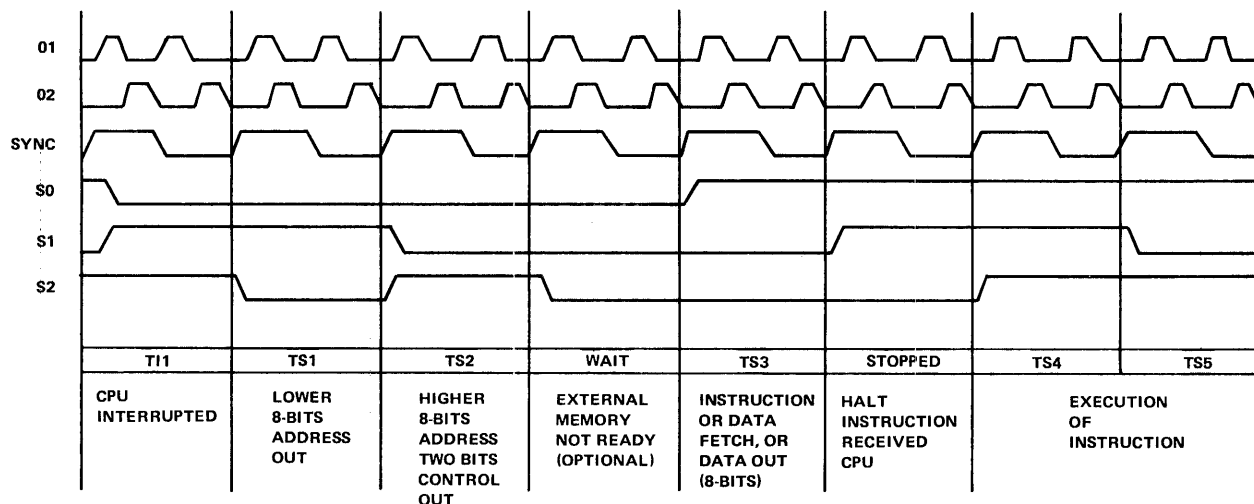

Figure 3-1 Microprocessor Signal Interface

11-4856



11-4859

Figure 3-2 Timing Diagram - Microprocessor Instruction

3.1.2 State Control

The microprocessor operates as a sequential state machine, controls the use of the data bus, and, according to its stored program, determines whether it sends or receives data. Output state signals S0, S1, and S2 are decoded externally and distributed to the peripheral control logic. Table 3-1 shows the coding of the state bits to yield a given phase.

3.1.3 Microprocessor Timing

The microprocessor machine cycle is shown in Figure 3-2. Since machine operation is asynchronous, the exact timing sequences depend on the instruction executed. A typical cycle may consist of five states. During T1 and T2, an address is sent to memory; at T3 time, instruction or data fetch occurs; T4 and T5 provide execution time.

A number of microprocessor instructions may require up to three cycles and do not require the two execution states T4 and T5. As a result, cycle length is variable and the state counter determines whether T4 and T5 are to be executed or omitted. This is accomplished via the cycle control coding (Table 3-2) in bits D6 and D7. Cycle 1 is always an instruction fetch cycle (PCI). The second and third cycles are for data reading (PCR), data writing (PCW), or I/O operations (PCC). The cycle type bits D6 and D7 are present on the data bus during T2 time only.

Table 3-1 State Control Coding

S0	S1	S2	State
0	1	0	T1
0	1	1	T11
0	0	1	T2
0	0	0	WAIT
1	0	0	T3
1	1	0	STOPPED
1	1	1	T4
1	0	1	T5

Table 3-2 Cycle Coding

D ₆	D ₇	Cycle	Function
0	0	PCI	Designates the address is for a memory read (first byte of instruction).
0	1	PCR	Designates the address is for a memory read data (additional bytes of instruction or data).
1	0	PCC	Designates the data is a command I/O operation.
1	1	PCW	Designates the address is for a memory write data.

3.1.4 Transition State Diagram

Possible state transitions within the processor are shown in Figure 3-3. Note that a normal machine cycle would begin at cycle 1, run from T1-T5, and revert back to cycle 1 again. The state counter within the microprocessor operates as a 5-bit feedback shift register with the feedback path controlled by the current instruction. The number of states normally required by each instruction is discussed in Chapter 4.

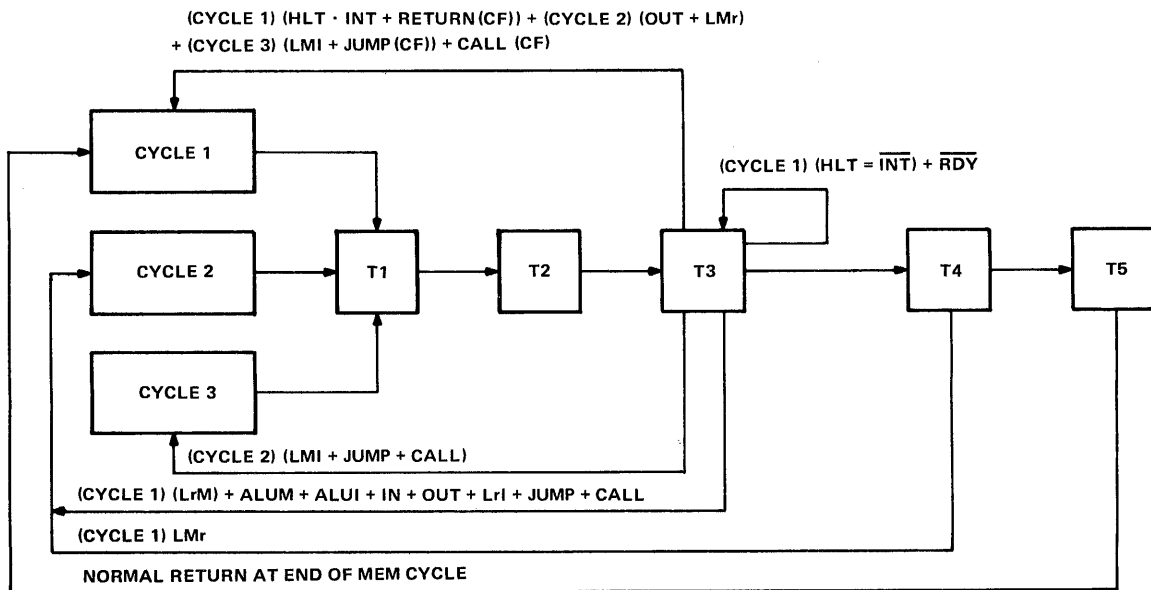

NOTE: CF = Failure Condition

11-4857

Figure 3-3 Transition State Diagram

3.1.5 System Start-Up

The microprocessor of the interface module is running any time power is applied to the system. When power (VDD) and clocks (01, 02) are first turned on, a flip-flop internal to the microprocessor is set by sensing the rise of VDD. This internal signal forces a HALT (00000000) into the instruction register and the microprocessor is then in the stopped state. The next 16 clock periods are required to clear internal chip memories and other external logic and registers. Upon clearing the registers the system is ready for operation. If for any reason during operation, the microprocessor decodes a HALT, the system reverts to the beginning of the program after 16 clock periods.

3.2 INTERFACE MODULE REGISTERS AND CONTROLS (Figure 2-1)

3.2.1 Address Register

This is the principal buffer register between the microprocessor and the rest of the interface module logic. It has a capacity of 16 bits (two 8-bit bytes). The low order byte is loaded by time state TS1 and the high order byte by time state TS2 during each cycle.

3.2.2 Bus Address Register

The bus address register buffers address data between the interface module and the Unibus. Address information may be loaded into this register at time state TS3.

3.2.3 Switch Register

Similar to the bus address register, the switch register buffers outgoing data. This element may also be loaded at TS3.

3.2.4 Data Bus Control

The principal function of the data bus control is to determine interface module operation during TS3 time. It determines, through input bit coding, the type of function to be performed (i.e., RAM control, ROM enable) or programs any of its other I/O in accordance with the stored program.

3.2.5 Unibus Control

This register is also loaded at TS3 and is selected by the data bus control for activation at that time. According to its input coding, U.C.R. may issue a HALT request, BUS INIT, enable-data bus-to-bus, or generate a bus master sync in addition to other functions.

CHAPTER 4 MICROPROCESSOR INSTRUCTION DESCRIPTION

4.1 DATA AND INSTRUCTION FORMATS

Data in the CPU is stored in the form of 8-bit binary integers. All data transfers to the system data bus will be in the same format.

$D_7 D_6 D_5 D_4 D_3 D_2 D_1 D_0$

DATA WORD

The program instructions may be one, two, or three bytes in length. Multiple byte instructions must be stored in successive words in program memory. The instruction formats then depend on the particular operation executed.

One Byte Instructions

$D_7 D_6 D_5 D_4 D_3 D_2 D_1 D_0$	OP CODE	Register to register, memory reference I/O arithmetic or logical, rotate or return instructions.
-----------------------------------	---------	--

Two Byte Instructions

$D_7 D_6 D_5 D_4 D_3 D_2 D_1 D_0$	OP CODE	Immediate mode instructions.
$D_7 D_6 D_5 D_4 D_3 D_2 D_1 D_0$	OPERAND	

Three Byte Instructions

$D_7 D_6 D_5 D_4 D_3 D_2 D_1 D_0$	OP CODE	JUMP or CALL instructions
$D_7 D_6 D_5 D_4 D_3 D_2 D_1 D_0$	LOW ADDRESS	
$X X D_5 D_4 D_3 D_2 D_1 D_0$	HIGH ADDRESS*	

*For the third byte of this instruction, D_6 and D_7 are "don't care" bits.

4.2 MICROPROCESSOR INSTRUCTIONS

4.2.1 Index Register Instructions

The load instructions do not affect the flag flip-flops. The increment and decrement instructions affect all flip-flops except the carry.

Mnemonic	Minimum States Required	Instruction Code						Description of Operation
		D ₇ D ₆	D ₅ D ₄ D ₃	D ₂ D ₁ D ₀				
(1) Lr ₁ r ₂	(5)	1 1	D D D	S S S				Load index register r ₁ with the content of index register r ₂ .
(2) LrM	(8)	1 1	D D D	1 1 1				Load index register r with the content of memory register M.
LMr	(7)	1 1	1 1 1	S S S				Load memory register M with the content of index register r.
(3) LrI	(8)	0 0	D D D	1 1 0	B B	B B B	B B B	Load index register r with data B . . . B.
LMI	(9)	0 0	1 1 1	1 1 0	B B	B B B	B B B	Load memory register M with data B . . . B.
INr	(5)	0 0	D D D	0 0 0				Increment the content of index register r (r ≠ A).
DCr	(5)	0 0	D D D	0 0 1				Decrement the content of index register r (r ≠ A).

4.2.2 Accumulator Group Instructions

The result of the ALU instructions affect all of the flag flip-flops. The rotate instructions affect only the carry flip-flop.

Mnemonic	Minimum States Required	Instruction Code						Description of Operation
		D ₇ D ₆	D ₅ D ₄ D ₃	D ₂ D ₁ D ₀				
ADr	(5)	1 0	0 0 0	S S S				Add the content of index register r, memory register M, or data B . . . B to the accumulator. An overflow (carry) sets the carry flip-flop.
ADM	(8)	1 0	0 0 0	1 1 1				
ADI	(8)	0 0	0 0 0	1 0 0	B B	B B B	B B B	
ACr	(5)	1 0	0 0 1	S S S				Add the content of index register r, memory register M, or data B . . . B to the accumulator with carry. An overflow (carry) sets the carry flip-flop.
ACM	(8)	1 0	0 0 1	1 1 1				
ACI	(8)	0 0	0 0 1	1 0 0	B B	B B B	B B B	

Mnemonic	Minimum States Required	Instruction Code								Description of Operation
		D ₇	D ₆	D ₅	D ₄	D ₃	D ₂	D ₁	D ₀	
SUr	(5)	1	0	0	1	0	S	S	S	Subtract the content of index register r, memory register M, or data B . . . B from the accumulator. An underflow (borrow) sets the carry flip-flop.
SUM	(8)	1	0	0	1	0	1	1	1	
SUI	(8)	0	0	0	1	0	1	0	0	
SBr	(5)	1	0	0	1	1	S	S	S	Subtract the content of index register r, memory register M, or data B . . . B from the accumulator with borrow. An underflow (borrow) sets the carry flip-flop.
SBM	(8)	1	0	0	1	1	1	1	1	
SBI	(8)	0	0	0	1	1	1	0	0	
NDr	(5)	1	0	1	0	0	S	S	S	Compute the logical AND of the content of index register r, memory register M, or data B . . . B with the accumulator.
NDM	(8)	1	0	1	0	0	1	1	1	
NDI	(8)	0	0	1	0	0	1	0	0	
XRr	(5)	1	0	1	0	1	S	S	S	Compute the Exclusive OR of the content of index register r, memory M, or data B . . . B with the accumulator.
XRM	(8)	1	0	1	0	1	1	1	1	
XRI	(8)	0	0	1	0	1	1	0	0	
ORr	(5)	1	0	1	1	0	S	S	S	Compute the Inclusive OR of the content of index register r, memory register M, or data B . . . B with the accumulator.
ORM	(8)	1	0	1	1	0	1	1	1	
ORI	(8)	0	0	1	1	0	1	0	0	
CPr	(5)	1	0	1	1	1	S	S	S	Compare the content of index register r, memory register M, or data B . . . B with the accumulator. The content of the accumulator is unchanged.
CPM	(8)	1	0	1	1	1	1	1	1	
CPI	(8)	0	0	1	1	1	1	0	0	
RLC	(5)	0	0	0	0	0	0	1	0	Rotate the content of the accumulator left.
RRC	(5)	0	0	0	0	1	0	1	0	Rotate the content of the accumulator right.
RAL	(5)	0	0	0	1	0	0	1	0	Rotate the content of the accumulator left through the carry.
RAR	(5)	0	0	0	1	1	0	1	0	Rotate the content of the accumulator right through the carry.

4.2.3 Program Counter and Stack Control Instructions

Mnemonic	Minimum States Required	Instruction Code				Description of Operation
		D ₇ D ₆	D ₅ D ₄ D ₃	D ₂ D ₁ D ₀		
(4) JMP	(11)	0 1	X X X	1 0 0		Unconditionally jump to memory address B ₃ . . . B ₃ B ₂ . . . B ₂ .
		B ₂ B ₂	B ₂ B ₂ B ₂	B ₂ B ₂ B ₂		
		X X	B ₃ B ₃ B ₃	B ₃ B ₃ B ₃		
(5) JFc	(9 or 11)	0 1	0 C ₄ C ₃	0 0 0		Jump to memory address B ₃ . . . B ₃ B ₂ . . . B ₂ if the condition flip-flop c is false. Otherwise, execute the next instruction in sequence.
		B ₂ B ₂	B ₂ B ₂ B ₂	B ₂ B ₂ B ₂		
		X X	B ₃ B ₃ B ₃	B ₃ B ₃ B ₃		
(5) JTc	(9 or 11)	0 1	1 C ₄ C ₃	0 0 0		Jump to memory address B ₃ . . . B ₃ B ₂ . . . B ₂ if the condition flip-flop c is true. Otherwise, execute the next instruction in sequence.
		B ₂ B ₂	B ₂ B ₂ B ₂	B ₂ B ₂ B ₂		
		X X	B ₃ B ₃ B ₃	B ₃ B ₃ B ₃		
(4) CAL	(11)	0 1	X X X	1 1 0		Unconditionally call the subroutine at memory address B ₃ . . . B ₃ B ₂ . . . B ₂ . Save the current address (up one level in the stack).
		B ₂ B ₂	B ₂ B ₂ B ₂	B ₂ B ₂ B ₂		
		X X	B ₃ B ₃ B ₃	B ₃ B ₃ B ₃		
(5) CFc	(9 or 11)	0 1	0 C ₄ C ₃	0 1 0		Call the subroutine at memory address B ₃ . . . B ₃ B ₂ . . . B ₂ if the condition flip-flop c is false, and save the current address (up one level in the stack). Otherwise, execute the next instruction in sequence.
		B ₂ B ₂	B ₂ B ₂ B ₂	B ₂ B ₂ B ₂		
		X X	B ₃ B ₃ B ₃	B ₃ B ₃ B ₃		
(5) CTc	(9 or 11)	0 1	1 C ₄ C ₃	0 1 0		Call the subroutine at memory address B ₃ . . . B ₃ B ₂ . . . B ₂ if the condition flip-flop c is true, and save the current address (up one level in the stack). Otherwise, execute the next instruction in sequence.
		B ₂ B ₂	B ₂ B ₂ B ₂	B ₂ B ₂ B ₂		
		X X	B ₃ B ₃ B ₃	B ₃ B ₃ B ₃		
(4) RET	(5)	0 0	X X X	1 1 1		Unconditionally return (down one level in the stack).
(5) RFc	(3 or 5)	0 0	0 C ₄ C ₃	0 1 1		Return (down one level in the stack) if the condition flip-flop c is false. Otherwise, execute the next instruction in sequence.
(5) RTc	(3 or 5)	0 0	1 C ₄ C ₃	0 1 1		Return (down one level in the stack) if the condition flip-flop c is true. Otherwise, execute the next instruction in sequence.
RST	(5)	0 0	A A A	1 0 1		Call the subroutine at memory address AAA000 (up one level in the stack).

CHAPTER 5 INTERFACE MODULE DETAILED LOGIC DESCRIPTION

5.1 INTRODUCTION

Keypad operation initiates appropriate microprocessor routines which perform certain data transfers within the interface module, between the interface module and the Unibus, and between the interface module and the programmer's console display. Prior to discussing the interface module logic, the sequences (i.e., register transfer, I/O operations, etc.) which occur after pressing a given key are briefly described.

Figure 5-1 shows the 16-word by 8-bit scratchpad RAM and its address allocations. This data is also summarized in Table 5-1. The keypad image within the RAM is shown in Figure 5-2.

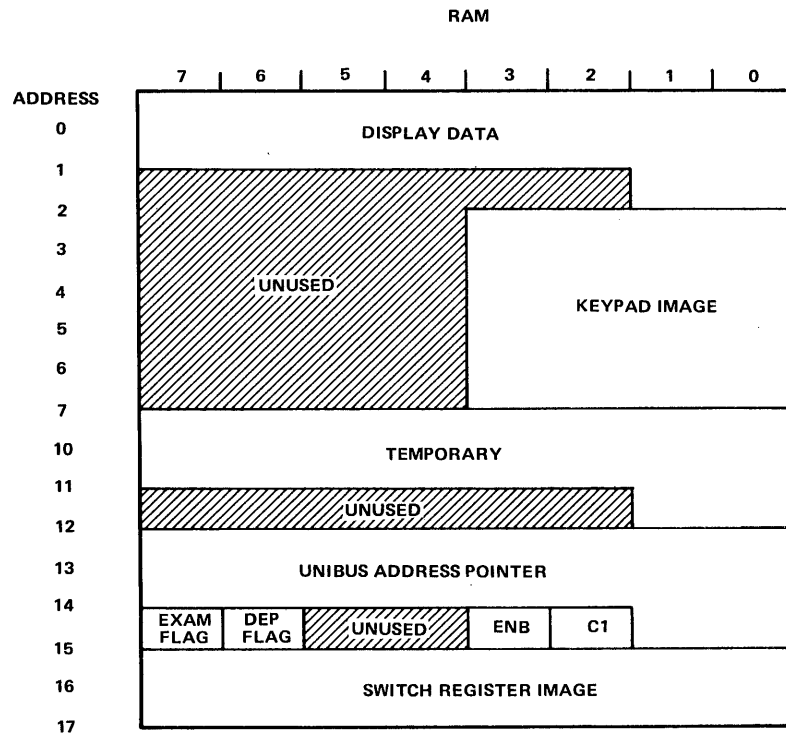

11-4853

Figure 5-1 RAM Address Allocations

KEYPAD IMAGE				
	3	2	1	0
3	CLR	LSR	LAD	DIS AD
4	0	1	4	7
5	INIT	2	5	EXAM
6	CNTRL	3	6	DEP
7	START	BOOT	CONT	HLT/SS

11-4854

Figure 5-2 Keypad Image

Table 5-1 RAM Function Address Assignments

Function	Address (Octal)	Address Bits
Display Data (18 bits)	Word 0	Bits 0-7
	Word 1	Bits 0-7
	Word 2	Bits 0, 1
Keypad Image (20 bits)	Word 3	Bits 0-3
	Word 4	Bits 0-3
	Word 5	Bits 0-3
	Word 6	Bits 0-3
	Word 7	Bits 0-3
Temporary Data Buffer (18 bits)	Word 10	Bits 0-7
	Word 11	Bits 0-7
	Word 12	Bits 0, 1
Unibus Address Pointer (18 bits)	Word 13	Bits 0-7
	Word 14	Bits 0-7
	Word 15	Bits 0, 1
EXAM FLAG	Word 15	Bit 7
DEP FLAG	Word 15	Bit 6
ENB FLAG	Word 15	Bit 3
C1 FLAG	Word 15	Bit 2
Switch Register Image (16 bits)	Word 16	Bits 0-7
	Word 17	Bits 0-7

5.2 PROGRAMMER'S CONSOLE KEYPAD FUNCTION SEQUENCES

5.2.1 Console Mode Key Functions

NUMERICS (0-7)

1. Value of Key (left shifted) → Temporary Data Buffer
2. Temporary → Display
3. Clear indicators.

LAD

1. Temporary → Unibus Address Pointer
2. Zero → Temporary
3. Temporary → Display
4. Clear/Indicators.

LSR

1. Temporary → Switch Register Image
2. Switch Register Image → Switch Register
3. SR DISP indicator is set.

CLR

1. Zero → Temporary
2. Temporary → Display
3. Clear indicators.

EXAM

1. Pre-increment Unibus address pointer if the EXAM flag is set.
2. Unibus Address Pointer → Bus Address Register
3. Bus Address Register → Unibus Address
4. Assert MSYN.

NOTE

Console waits for BUS SSYN to be returned. If SSYN does not occur within 20 μ s, the transfer is aborted and the BUS ERR indicator is set.

5. Unibus Data → Temporary
6. Temporary → Display
7. Set EXAM flag.

DEP

1. Pre-increment Unibus address pointer if the DEP flag is set.
2. Unibus Address Pointer → Bus Address Register with C1 = 1.
3. Bus Address Register → Unibus Address
4. Temporary → Switch Register
5. Switch Register → Unibus Data
6. Assert MSYN.

NOTE

Console waits for BUS SSYN to be returned. If SSYN does not occur within 20 μ s, the transfer is aborted and the BUS ERR indicator is set.

7. Set DEP flag.
8. Switch Register Image → Switch Register

DIS AD

1. Unibus Address Pointer → Display
2. Clear EXAM or DEP flag if set.

CNTRL-INIT

1. Set BUS INIT and HALT REQUEST for 150 ms.

CNTRL-HLT/SS

1. Clears BUS SACK/BUS BUSY if set and sets HALT REQUEST
2. When HALT BUSY is active, sets 777707 → Bus Address Register
3. Bus Address Register → Unibus Address
4. Assert MSYN

NOTE

Console waits for BUS SSYN to be returned. If SSYN does not occur within 20 μ s, the transfer is aborted and the BUS ERR indicator is set.

5. Unibus Data → Temporary
6. Temporary → Display

CNTRL-CONT

1. Clears BUS SACK and BUS BUSY.
2. Switch Register Image → Display
3. Set SR DISP indicator.

CNTRL-BOOT

1. Sets and clears BOOT signal
2. Switch Register Image → Display
3. Set SR DISP indicator.

CNTRL-START

1. 777707 → Bus Address Register with C1 = 1
2. Bus Address Register → Unibus Address
3. Unibus Address Pointer → Switch Register
4. Switch Register → Unibus Data
5. Assert MSYN.

NOTE

Console waits for BUS SSYN to be returned. If SSYN does not occur within 20 μ s, the transfer is aborted and the BUS ERR indicator is set.

6. Switch Register Image → Switch Register
7. Assert BUS INIT for 150 ms.
8. Switch Register Image → Display
9. Set SR DISP indicator.

CNTRL-7

1. Unibus Address Pointer + Temporary +2 → Temporary

CNTRL-6

1. Temporary + Switch Register Image → Temporary

CNTRL-1

1. Set maintenance indicator.
2. MPC Lines (sampled) → Display

5.2.2 Maintenance Mode Key Functions

CLR

1. Clears indicators.
2. Clears manual clock enable, if set.
3. Goes to halt condition.

DIS AD

1. Unibus Address (sampled) → Display

EXAM

1. Unibus Data (sampled) → Display

HLT/ISS

1. Sets manual clock enable.
2. Clears BUS SACK and BUS BUSY.
3. MPC (sampled) → Display

CONT

1. Sets and clears manual clock
2. MPC (sampled) → Display

BOOT

1. Sets and clears BOOT signal.

START

1. Clears manual clock enable, if set.
2. MPC (sampled) → Display

No. 5

1. Sets TAKE BUS signal, forcing console to assert BUS BUSY.

5.3 DETAILED LOGIC DESCRIPTION

5.3.1 Clock Circuitry

The M7859 Interface board is driven by an MC 4024 (E42) 1-MHz clock (drawing CS M7859-0-1, sheet 2). The 1-MHz output at E42-8 is toggled down to two nonoverlapping 500-kHz pulses at E12-5, 6, and E30, and these pulses are applied to the microprocessor (E18) input as 01 and 02. The 02 clock, designated as KY1 CK2 H and KY1 CK2 L, is also used as a control pulse to clear system registers and together with the sync pulse to define the end of a timing cycle.

Figure 5-1 shows the relation between the two clock pulses.

5.3.2 Power-Up Logic/Interrupt (Drawing CS M7859, Sheet 2)

The power-up logic/interrupt circuitry is comprised of E1-6, E40-10, E1-4, E36, E12, E29-1, E6, and E26. These elements sense when the system turns on, generate the interrupt to the microprocessor needed to start it, and clear registers to force program startup at location 0.

BUS DC LO at E1-3 initiates the function by clearing E36 which is configured as an 8-bit counter and generates KY1 PUP 1 L. This signal is routed to the Unibus control, indicator control, switch register, and bus address register as a master clear line. The address register is provided with its own clear line, KY1 ADR CLR L.

BUS DC LO L puts the microprocessor in the STOP state. The counter starts counting in the STOP state (E6, E36). KY1 STOP L and KY1 C2 L at E29-1 clock E6. E6 is a divide by two on the clock, while E36 counts from 0-7. Sixteen clock periods are thus counted. At the transition of E36 from 7 to 0, the interrupt is generated at E12-8 and the microprocessor goes into the T1I state (Interrupt). KY1 T1I L and KY1 CK2 L then reset E12 and clear the address register via E6-6 and the system is initialized.

5.3.3 Microprocessor (Drawing CS M7859, Sheet 2)

The 8008 Microprocessor Chip (E18) was discussed in detail in Chapter 3. According to drawing CS M7859, sheet 2, the unit communicates over an 8-bit bidirectional data bus via 8833 tristate transceivers E16 and E17, with the satellite logic of the interface module. A single interrupt line is received from the power-up logic to initiate microprocessor operations. Driven by a 2-phase, 500-kHz clock (Figure 5-1), the element yields a 3-bit state output code, S0, S1, and S2, plus a sync pulse, to drive a 7442 Timing Phase Decoder. The latter element provides eight separate timing cycles for the sequencing of interface module data transfers and other discrete operations.

5.3.4 Timing State Decoder

The timing state decoder (E23) receives the state outputs S0, S1, and S2 from the microprocessor and generates the timing states for the interface modules (drawing CS M7859, sheet 2). This unit is a 7442 4-line to 10-line decoder, with two unused outputs, that yields an 8-output sequence according to its 3-input state code. State control coding is presented in Chapter 3. State control inputs are determined in the microprocessor and depend on an internal 5-bit feedback shift register with the feedback path controlled by the instruction being executed.

5.3.5 Address Register (Drawing CS M7859, Sheet 2)

The address register, the principal buffer between the microprocessor and the remainder of the interface module logic, consists of four 74175 quad, D-type, double rail output latches. The low order bits are handled by E5 and E4 which generate KY1 ADRD 0 L through KY1 ADRD 3 L (E5) and their complements (for RAM addressing), and KY1 ADRD 4 H through KY1 ADRD 7 H (E4), respectively. This 8-bit byte is the low order unit of the address or data with E10 and E28 containing the high order information ADRD 08-13 and PC FUN 1 and 0.

The data contained in the address register is routed to the following locations according to direction by the stored program:

1. ROM (address of next instruction)(KY1 ADRD 0 L → KY1 ADRD 8 L plus ROM 1 EN L or ROM 2 EN L)
2. RAM (address of data to be read or written) (KY1 ADRD 0 L → KY1 ADRD 3 L)
3. Unibus Control (KY1 ADRD 0 H → KY1 ADRD 3 H)
4. Indicator Control (KY ADRD 4 H → KY1 ADRD 7 H)
5. Data Bus Control (KY1 ADRD 9 H → KY1 ADRD 13 H, KY1 PC FUN 0 H, KY1 PC FUN 1 H)
6. Switch Register (KY1 ADRD 0 H → KY1 ADRD 7 H)
7. Bus Address Register (KY ADRD 0 H → KY1 ADRD 7 H)

The address register is loaded with a low order byte (E4 and E5) by signal KY1 LD AD 1 H, generated by AND E22-12 at time state TS1. The high order byte is gated in E28 and E10 by KY1 LD AD 2 H generated at E22-6 at timing state TS2.

5.3.6 ROM

The interface module ROM consists of E3, E21, E33, and E39 (drawing CS M7859, sheet 3). The four 512-word by 4-bit elements are addressed so that the ensemble looks like two 512- × 8-bit RMs. E3 and E21 are activated by KY4 ROM 1 EN L and E33 and E39 by KY4 ROM 2 EN L. Address bits KY1 ADRD 0 H through KY1 ADRD 8 H are routed to all four ROM elements with the enable 1 or 2 determining the address activated and thus yielding 1024 8-bit locations. Outputs are wire ORed with various inputs to give the KY2 DIN 0 H through KY2 DIN 7 H inputs to the tristate transceivers, E16 and E17.

The ROM 1 or RM 2 enables are generated by the data bus control logic.

5.3.7 RAM

The scratchpad RAM consists of E11 and E27 (drawing CS M7859, sheet 3). These units effectively comprise a 16-word by 8-bit read/write memory, and serve as working storage for the microprocessor programs in storing addresses and data. Data is routed to the RAM (KY1 DOUT 0 H through KY1 DOUT 7 H) directly from the tristate transceivers of the microprocessor bidirectional data bus during RAM write operations. The 4-bit address lines KY1 ADRD 0 L through KY1 ADRD 3 L specify the address to be read from or written into during read/write.

Selection of the RAM for read or write is determined by the stored program via the data bus control. Either KY4 RAM → DIN BUS L or KY4 RAM WRITE H must be true to select the RAM. Output lines are wire ORed with various other microprocessor input ports to be routed to the 8833 tristate transceivers.

5.3.8 Switch Register (Drawing CS M7859, Sheet 6)

The switch register contains the 16-bit data used and consists of four 74175 quad, D-type, double rail output latches. The four elements comprising the register are E9, E19, E2, and E15. These units feed the 8641 bus transceivers E7, E25, E8, and E13 (respectively). Incoming 16-bit data (KY5 BB D00 H through KY5 BB D15 H) is applied to the 8093 tristate buffers and gated by an appropriate read line from the data bus control. Outgoing data (BUS D00 L through BUS D15 L) is gated by KY4 EN DB L, a signal generated in the switch register address decoding logic (sheet 5).

The switch register is addressable from the Unibus as address 777570 as described in Paragraph 5.3.9.

5.3.9 Switch Register Address Decode Logic (Drawing CS M7859, Sheet 5)

The switch register address decoding logic allows the Unibus to address the switch register via a decoding of address 777570. The logic has two outputs:

1. BUS SSYN L
2. KY4 EN DB → BUS L

K44 EN DB → BUS L at E43-10 gates the data lines onto the Unibus (CS M7859, sheet 6) while the assertion of BUS SSYN L designates that the slave device has completed its part of the data transfer. The second stage of the address decode at E32 is gated by assertion of BUS MSYN L at E32-10. Assertion of MSYN requests that the slave defined by the A (address) lines perform the function required by the C lines. In this case, KY7 BB C1 H at inverter E40-9 specifies that the data is to be transferred to the Unibus data lines.

5.3.10 Bus Address Register (Drawing CS M7859, Sheets 7 and 8)

The bus address register consists of five 74175 quad, D-type, double rail output latches. The five elements comprising the register are E67, E57, E73, E58, and E51. Input to the bus address register is from the address register (KY1 ADRD 0 H through KY1 ADRD 7 H). Outputs are routed to the display and keypad logic and to the 8641 Unibus transceivers E61, E56, E65, E55, and E50.

A Unibus address is enabled to the Unibus via the bus address transceivers from the bus address register by KY7 EN AR L generated at E51-11. The switch register is available to the Unibus as address 777570 via the bus address transceivers and the switch register decode logic. The latter function is discussed in Paragraph 5.3.9.

E67 and E57 contain the keypad scan signals (KY6 SCAN 1 L through KY6 SCAN 6 L) while E73 drives the display (KY6 NUM 1 H through KY6 NUM 3 H).

Incoming 18-bit address information (KY6 BB A00 H through KY7 BB A17 H) is applied to the 8093 tristate buffers and gated by an appropriate read line from the data bus control.

5.3.11 Data Bus Control Logic (Drawing CS M7859, Sheet 5)

The data bus control directs the reading and loading of the various interface module registers, the reading of the ROMs, and the reading/writing of the RAM. It also determines the direction of data flow in the interface module and between the interface module and the Unibus, i.e., whether data will be read from or be routed to the Unibus. A list of I/O functions and associated select signals follows:

Select Signal	Function
READ INPUT 0 L	UNIBUS DATA
READ INPUT 1 L	
READ INPUT 2 L	UNIBUS ADDRESS
READ INPUT 3 L	
READ INPUT 4 L	
READ INPUT 5 L	KEYPAD REG
READ INPUT 6 L	MAINTENANCE
READ INPUT 7 L	
LD REG 0 H	BUS ADDR REG
LD REG 1 H	
LD REG 2 H	
LD REG 3 H	SWITCH REG
LD REG 4 H	
LD REG 5 H	UNIBUS CONT LOGIC
EN ROM 1 L	ROM SELECT
EN ROM 2 L	
RAM WRITE H	RAM WRITE
RAM DIN BUS L	ENABLE RAM DATA
DIN DRIVERS DIS H	DISABLE DATA IN

Specifically, the data bus control logic decodes memory references into three areas (ROM 1, ROM 2, and RAM) and determines whether the access is a read or write. The logic also decodes I/O instructions and generates loading or gating signals depending on the direction of data transfer and the port selected.

In order to facilitate understanding of the logic, the following explanation of memory address allocation and I/O instruction operation is included.

ROM 2 (E33 and E39)

Memory addressing space spans locations 0 through 777.

ROM 1 (E3 and E21)

Memory addressing space spans locations 4000 through 4777.

RAM (E11 and E27)

Memory addressing space spans locations 20000 through 20017.

The two bus control signals provided by the microprocessor and latched with the upper byte of the address register, KY1 PC FUN 0 H and KY1 PC FUN 1 H, determine data transfer direction and I/O operations. The following table explains the decoding of these signals.

PC FUN 0	PC FUN 1	
L	L	Memory read of first byte of instruction only (fetch)
L	H	Memory read of additional bytes of instruction or data.
H	H	Memory write (used only to write into RAM).
H	L	I/O operation

Memory reads and writes signify that the address register (KY1 ADRD 0 H through KY1 ADRD 13 H) contains the address of the location in memory to be accessed.

The code for I/O operations, however, signifies a very different situation. This is due to the following occurring after the initial instruction fetch cycle:

1. During TS1 the content of the A register (accumulator) in the microprocessor is available on the data lines and is latched into the low byte of the address register.
2. During TS2 the content of the instruction register (containing the I/O instruction) is available on the data lines and is latched into the high byte of the address register.
3. During TS3 of an INP (input) instruction, data on the data lines is loaded into the A register. On OUT (output) instructions, the data is strobed out of the low byte of the address register.

I/O Instruction Code:

```
INP 01 OOMMM1
OUT 01 RRRMM1
```

Note that the two most significant bits of the instruction will correspond to PC FUN 0 = 1 and PC FUN 1 = 0 when loaded into the high byte of the address register, thus denoting an I/O operation. Therefore, the data bus control logic determines whether to gate data into the microprocessor during TS3 (INP) or to load the data from the low byte of the address register into an output port during TS3 (OUT).

The 32 × 8 PROM (E34) does the initial decoding of the type of transfer (read, write, or I/O) from the signals KY1 PC FUN 0 H and KY1 PC FUN 1 H. If the transfer is a memory read or write, it is decoded into one of the following four signals. KY4 RAM → DIN BUS L (RAM read), KY4 ROM 1 EN L (memory read in address range 4000–4777), KY4 ROM 2 EN L (memory read in address range 000–777), and an enable which is ANDed with KY1 SYNC H, KY1 TS3 L, and KY1 CK2 L to provide a write pulse, KY4 RAM WRITE H, to the RAM.

Another enable from the PROM is ANDed with KY1 TS3 L to provide the signal KY4 DIN DRIVER DIS H. This signal is normally high, disabling the driver portions of the 8833 transceivers (E16 and E17). It will be low only during TS3 and when data transfer is into the microprocessor.

Two other outputs of the PROM are used for I/O operations. One output of the PROM (E34-7), when low, enables the 74154 4-to-16 decoder on all I/O instructions. The second output (E34-9) determines whether the I/O instruction is INP or OUT. If the instruction is OUT, then the signal will be high.

Note that address register bits KY1 ADRD 11, KY1 ADRD 10 H, and KY1 ADRD 9 H, are applied to the low order inputs of the 74154. This selects which of the possible ports will be used. The fourth input, the highest order input, determines if it is an INP or OUT instruction. This input is the ANDed condition of the PROM output (E34-9), KY1 SYNC H, KY1 TS3, and KY1 CK2. Thus, if the instruction is an INP, then the input gating signal will be one of the lower order eight outputs of the 74154 (KY4 READ IN 0 L through KY4 READ IN 7 L).

If the PROM signal (E34-9) is high, signifying an OUT instruction, then initially a low order output is selected (does not substantially affect anything) and then a high order output will be pulsed as the gated clock pulse is applied to the high order input of the 74154. Thus, the high order outputs are pulsed and buffered to provide loading pulses to the selected registers (KY4 LD REG 0 H, etc.).

5.3.12 Unibus Control (Drawing CS M7859, Sheet 5)

Unibus control is accomplished via two 74175 quad, D-type, double rail output latches, E52 and E64. The stored program input bit configurations are read in under control of an appropriate data bus control signal, LD REG 5 H. E64 D2 and D3 latches are utilized for the manual clock enable and manual clock lines while the other six lines are Unibus control signals.

5.3.13 Keypad Scan Logic (Drawing CS 5411800-0-1)

The logic and driving circuitry for the keypad and display elements is located on a circuit board in the rear of the programmer's console panel.

Scan signals for the keypad are generated at the interface module (bus address register). These six lines (KY6 SCAN 1 L through KY6 SCAN 6 L) are then routed through hex 7417 buffer drivers to the console circuit board where they are designated as READ and DRIVE signals. As indicated by CS 5411800-0-1, sheet 2, READ 1 through READ 5 signals continuously scan the keypad in groups of 4. As each READ signal is applied to check for a pressed key, a corresponding DRIVE signal is simultaneously generated and applied to the appropriate transistor in the LED display circuitry (CS 11800-0-1, sheet 3).

A pressed key thus results in activation of 1 to 4 lines. This information is routed out through J1 to the interface module and applied to the data bus for eventual read-in to the microprocessor.

5.3.14 Indicator Logic (Drawing CS M7859, Sheet 5)

The indicator control consists of a single quad, D-type, latch configuration, 74175 (E68) and four 7417 open collector inverters (E69) for driving the panel indicators. Input bit coding KY1 ADRD 4 H through KY1 ADRD 7 H via the stored program determines which of the following panel indicators are turned on:

1. BUS ERR
2. SR DISP
3. MAINT
4. BOOT

5.3.15 Halt Logic (Drawing CS M7859-0-1, Sheet 9)

The halt logic allows the console to obtain control of the Unibus in order to perform Unibus transactions. Control of the Unibus is passed to the KY11-LB from the PDP-11 processor via a HALT REQUEST and HALT GRANT sequence. Use of the HALT/SS key initiates a program sequence within the KY11-LB to issue a HALT REQUEST to the PDP-11 processor. The processor will arbitrate the request and at the appropriate time will respond with HALT GRANT. The reception of HALT GRANT H by the halt logic direct sets the HALT SACK flip-flop on E63-4, causing BUS SACK L to be generated at E62-13. The set output of the HALT SACK flip-flop (E63-5) sets up the data input of the HALT BUSY flip-flop (E63-12).

The reception of BUS SACK L by the PDP-11 processor will cause it to drop HALT GRANT H. When the Unibus becomes free (unasserted BUS BUSY L and BUS SSYN L), the E63-11 will be clocked, setting the HALT BUSY flip-flop. This, in turn, asserts BUS BUSY L through E62-10 and causes the RUN indicator to be turned off via the 7417 buffer (E66-12). This logic operates in the same manner if the HALT GRANT is generated not by a HALT REQUEST from the KY11-LB but by a HALT instruction in the PDP-11 processor. The output of the HALT BUSY flip-flop (KYB HALT BUSY H) can be tested by the microprocessor program to check if the console has control of the Unibus before performing Unibus transactions.

The HALT SACK and HALT BUSY flip-flops are direct cleared by either BUS INIT L from the Unibus or by the signal KY4 CLR BUS L which can be generated by the microprocessor program. Clearing these flip-flops relinquishes control of the Unibus to the PDP-11 processor.

The signal KY4 TAKE BUS L, which can direct set the HALT BUSY flip-flop, allows the microprocessor program to perform Unibus operations without first obtaining the Unibus through a legal request. This signal is only used during maintenance mode operation of the KY11-LB to bypass a failing or hung processor.

5.3.16 Buffers (Drawing CS M7859, Sheet 4)

5.3.16.1 Tristate Buffers (8093) – The following units, which are gated by read input signals from the data bus control, buffer input data from several sources.

1. Unibus Data
2. Unibus Address
3. Keypad Register
4. Maintenance Inputs (from processor microprogram counter).

Outputs from the 8093s are wire ORed and sent to the tristate transceivers with the ROM and RAM data as KY2 DIN 0 H through KY2 DIN 7 H.

5.3.16.2 Tristate Transceivers (8833) – These units buffer data between the microprocessor bidirectional data bus and the satellite logic of the interface module.

CHAPTER 6 CONSOLE MODE OPERATION

6.1 INTRODUCTION

This chapter is a recapitulation of all console key and indicator functions. Operation, use, and examples of the utilization of each key are presented. Key operations are divided into console mode and maintenance mode. Examples of console sequences to demonstrate the proper use of the KY11-LB are presented together with further notes and hints on operation.

6.2 CONSOLE KEY OPERATIONS

This section describes the operation of each key in a step-by-step procedure. The reader is assumed to have read earlier chapters as some descriptions include the use of keys previously described.

A notation for each key will be introduced in each description and is enclosed in angle brackets < >. These notations are used extensively in Paragraph 6.4 to describe various sequences of key operations.

<CLR> - Used to clear an incorrect entry or existing data.

1. Press and release the CLR key.
2. The display (six digits) will be all zeros.
3. Clears the SR DISP, BUS ERR, or MAINT indicators if on.

Numerics 0-7 - Used to key in an octal numeric digit (0 through 7).

1. Press a numeric key (0 through 7).
2. The corresponding digit will be left shifted into the 6-digit octal display with the previously displayed digits also being left shifted.
3. Release the numeric key.

To enter the number <xxxxxx>, e.g., 123456:

1. Press and release the CLR key (000000 will be displayed).
2. Press and release the 1 key (000001 will be displayed).
3. Press and release the 2 key (000012 will be displayed).
4. Press and release the 3 key (000123 will be displayed).
5. Press and release the 4 key (001234 will be displayed).
6. Press and release the 5 key (012345 will be displayed).
7. Press and release the 6 key (123456 will be displayed).

The number has now been entered. Leading zeros do not have to be entered.

<LSR> - Used to load the switch register (accessible as Unibus address 777570).

1. Press and release the LSR key.
2. The display will show the data loaded and the SR DISP indicator will be on.

To load the number 777 i.e., **<LSR 777>**, into the switch register:

1. Press and release the CLR key.
2. Key in the number 777.
3. Press and release the LSR key.
4. 777 will be displayed and the SR DISP indicator will be on.

<LAD> - Used to load the Unibus address pointer prior to performing an EXAMINE, DEPOSIT, or START.

1. Press and release the LAD key.
2. Display will be all zeros.

To load address 200, i.e., **<LAD 200>**:

1. Press and release the CLR key.
2. Key in 200.
3. Press and release the LAD key.
4. Display is all zeros.

<DIS AD> - Displays the current contents of the Unibus address pointer.

1. Press and release the DIS AD key.
2. Display will show the current Unibus address pointer.

To perform the sequence:

LAD 400
DIS AD

1. Press and release the CLR key.
2. Key in 400.
3. Press and release the LAD key (display is all zeros).
4. Press and release the DIS AD key.
5. Display shows the 400 from the Unibus address pointer.

<DEP> - Used to deposit a number into the location pointed to by the Unibus address pointer.

1. Processor must be halted (RUN indicator off); otherwise key is ignored.
2. Press and release the DEP key.
3. Display shows the data deposited.

To deposit <DEP xxxx> (e.g., 5252) into location 1000, the sequence is as follows:

LAD 1000
DEP 5252

1. Press and release the CLR key.
2. Key in 1000.
3. Press and release the LAD key.
4. Key in 5252.
5. Press and release the DEP key.

<EXAM> - Used to examine the contents of a location pointed to by the Unibus address pointer.

1. Machine must be halted.
2. Press and release the EXAM key.
3. Display shows the contents of the location examined.

To examine general-purpose register R7 (program counter) at Unibus address 777707, the following sequence is used:

LAD 777707
EXAM

1. Press and release the CLR key.
2. Key in 777707.
3. Press and release the LAD key.
4. Press and release the EXAM key.
5. The contents of R7 will be displayed.

<CNTRL> - The CNTRL key is always used in conjunction with some other key. When it is used it must be pressed and held down while the second key is pressed and released.

<CNTRL-HLT/SS> - Used to halt the processor.

1. Press and hold down the CNTRL key.
2. Press and release the HLT/SS key.
3. Display will show the current contents of R7 (program counter) and the RUN indicator will be off.
4. Release the CNTRL key.

If the processor is already halted, the use of the HLT/SS key will single-instruction step the processor. (The CNTRL key is not required to single-instruction step the processor once halted.)

1. Press and release the HLT/SS key.
2. Processor will perform one instruction and halt.
3. Display will show the new current contents of R7 (program counter).

<CNTRL-CONT> - Used to allow the processor to begin running from a halt.

1. Press and hold down the CNTRL key.
2. Press and release the CONT key.
3. Processor will run unless a program halt instruction is encountered. The RUN and SR DISP indicators should be on and the contents of the switch register should be displayed. If a halt instruction was encountered, the indicators will be off and the program counter will be displayed.
4. Release the CNTRL key.

NOTE

If the processor is already running, use of <CNTRL-CONT> will result in the switch register being displayed; there will be no other effect on the processor.

<CNTRL-BOOT> - Used to initiate running of M9301 Bootstrap program.

1. Processor must be halted.
2. Press and hold down the CNTRL key.
3. Press and release the BOOT key.
4. Processor should start running (RUN indicator on) the bootstrap program selected on the M9301.

NOTE

For more information concerning the M9301 Bootstrap program, consult the system users guide.

5. Release the CNTRL key.

<CNTRL-START> - Used to start the processor running a program from a given starting address.

1. Processor must be halted; otherwise key is ignored.
2. Press and hold down CNTRL key.
3. Press and release the START key.
4. RUN indicator will be on unless a halt instruction is encountered. The SR DISP indicator should also be on and the contents of the switch register should be displayed.
5. Release the CNTRL key.

To start running a program at location 1000, the following sequence is used:

1. Press and release the CLR key.
2. Key in 1000.
3. Press and release the LAD key.
4. Press and hold down the CNTRL key.
5. Press and release the START key.
6. Release the CNTRL key.

<CNTRL-INIT> - Generates a Bus Initialize without the processor starting.

1. Processor must be halted.
2. Press and hold down the CNTRL key.
3. Press and release the INIT key.
4. Bus Initialize will be generated for 150 ms.
5. Release the CNTRL key.

<CNTRL-7> - Used to calculate the correct address when a mode 6 or 7 register R7 instruction is encountered.

1. Press and hold down the CNTRL key.
2. Press and release the 7 key.
3. Display will show the new temporary register which contains the old temporary register plus the Unibus address point or plus 2.

See Paragraph 6.4 for an example.

<CNTRL-6> - Used to calculate the offset address when mode 6 or 7 instructions other than register R7 are encountered.

1. Press and hold down the CNTRL key.
2. Press and release the 6 key.
3. Display shows the new temporary register, which contains the old temporary plus the switch register.
4. Release the CNTRL key.

See Paragraph 6.4 for an example.

<CNTRL-1> - Used to enter the console into maintenance mode. Maintenance mode should only be used as an aid to troubleshooting hardware problems. Maintenance mode provides no help in debugging software problems.

1. Press and hold down the CNTRL key.
2. Press and release the 1 key.
3. MAINT indicator will be on and the MPC (microprogram counter) will be sampled and displayed.
4. Release the CNTRL key.

6.3 NOTES ON OPERATION

An erroneous display will result if, while the processor is running and the switch register is being displayed, a numeric key is pressed. Although the SR DISP indicator will remain on, the display no longer reflects the actual contents of the switch register. If at any time while the processor is running, it is desired that the switch register contents be displayed, the CNTRL-CONT keys should be used.

As a general practice, prior to entering a new 6-digit number and if the display is nonzero, the CLR key should be used to initially zero the display.

In order to single-instruction step the processor from a given starting address, the program counter (R7) must be loaded with the starting address using the Unibus address of R7 (777707) i.e., to single-instruction step from the beginning of a program starting at location 1000, the following sequence is necessary:

```
LAD 777707
DEP 1000
CNTRL-INIT (if desired)
HLT/SS
HLT/SS
etc.
```

The console requires an 18-bit address. This is especially important to remember when accessing device registers (i.e., 777560 instead of 177560). Otherwise an erroneous access to memory or to a nonexistent address will occur.

The Unibus addresses for the general-purpose registers can only be used by the console. A PDP-11 program using the Unibus addresses for the general-purpose registers will trap as a nonexistent address. Also, internal registers R10 through R17, which are used for various purposes (depending upon processor), may be accessed by the console through Unibus addresses 777710 through 777717.

The BUS ERR indicator on the console reflects a bus error by the console only. The indicator will not reflect bus errors due to other devices such as the processor.

6.4 EXAMPLES OF CONSOLE SEQUENCES

This section combines key operations with example sequences to demonstrate the proper use of the KY11-LB Programmer's Console.

The following sequences use the notations for key operations as described in Paragraph 6.2.

The angle brackets < > will be used in the sequences to identify the display contents after the operation is performed, i.e., LAD 200 <0>

1. Press and release the CLR key.
2. Press and release 2 key.
3. Press and release 0 key.
4. Press and release 0 key.
5. Press and release the LAD key.
6. 000000 will be displayed in the 6-digit readout.

Example 1

This sequence uses the examine function and the switch register Unibus address 777570 to read the contents of the switch register.

LSR 123456	<123456>
LAD 777570	<0>
EXAM	<123456>
DIS AD	<777570>
LSR 777	<777>
EXAM	<777>

Example 2

This sequence demonstrates the use of the following keys: LAD, DIS AD, LSR, EXAM, DEP, CNTRL-START, CNTRL-CONT, and CNTRL-HLT/SS.

This example loads the following program into memory, which is then run to demonstrate various operations.

Program	Memory Location/Contents
1000/13737	;Move the contents of
1002/177570	the switch register to
1004/1014	memory location 1014
1006/0000	;Halt
1010/137	;Jump to location 1000
1012/1000	
1014/0000	

Sequence

LAD 1000	<0>
DEP 13737	<13737>
DEP 177570	<177570>
DEP 1014	<1014>
DEP 0	<0>
DEP 137	<137>
DEP 1000	<1000>
DEP 0	<0>
LAD 1000	<0>
EXAM	<13737>
EXAM	<177570>
EXAM	<1014>
EXAM	<0>
EXAM	<137>
EXAM	<1000>
EXAM	<0>
DIS AD	<1014>
LSR 123456	<123456>
LAD 1000	<0>
CNTRL-START	<1010>
LAD 1014	<0>
EXAM	<123456>
DEP 0	<0>
EXAM	<0>
DIS AD	<1014>
LSR 125252	<125252>
CNTRL-CONT	<1010>
LAD 1014	<0>
EXAM	<125252>
DEP 0	<0>
LAD 1006	<0>
DEP 240	<240>
EXAM	<240>
LAD 1000	<0>
CNTRL-START	<125252>
LSR 70707	<10707>
CNTRL-HLT/SS	
LAD 1014	<0>
EXAM	<10707>
HLT/SS	
HLT/SS	
HLT/SS	
.	
.	
.	
LSR 05252	<052525>
HLT/SS	
LAD 1014	<0>
EXAM	<052525>

Example 3

This sequence demonstrates the use of CNTRL-7 and CNTRL-6. The following data are loaded into memory:

1000/177
1002/100
1004/000
1006/5060
1010/1020

1104/1006

RO = 777760

The sequence to load the data is as follows:

LAD 1000	<0>
DEP 177	<177>
DEP 100	<100>
DEP 0	<0>
DEP 5060	<5060>
DEP 1020	<1020>
LAD 1104	<0>
DEP 1006	<1006>
LAD 777700	<0>
DEP 777760	<777760>

Sequence

LAD 1000	<0>
EXAM	<177>
EXAM	<100>
CNTRL-7	<1104>
LAD	<0>
EXAM	<1006>
LAD	<0>
EXAM	<5060>
EXAM	<1020>
LSR	<1020>
LAD 777700	<0>
EXAM	<777760>
CNTRL-6	<100006>
LAD	<0>
EXAM	<177>

CHAPTER 7

MAINTENANCE MODE OPERATION

7.1 INTRODUCTION

This chapter covers the keypad facilities of the programmer's console available for hardware maintenance of the processor.

7.2 MAINTENANCE MODE KEY OPERATIONS

The following definitions apply to a subset of the same keys used in console mode; however the functions and operations differ from those in console mode. In general, console mode functions are not available while in maintenance mode, and many keys have no function in maintenance mode.

NOTE

**Maintenance mode operation is indicated by the
MAINT indicator being on.**

In order to use the hardware maintenance features available in maintenance mode, the maintenance cable (11/04) or cables (11/34) must be connected between the KY11-LB interface board (M7859) and the corresponding processor board (M7263-11/04, M7266-11/34, M8266-11/34A, or M8267-FP11A). An exception to this is the 5 (maintenance mode) operation which allows the console to examine or deposit into memory or device registers without the processor being either present or functional.

DIS AD (Maintenance Mode) – Used to display Unibus address lines.

1. Press and release the DIS AD key.
2. Unibus address lines will be sampled (read once) and displayed, i.e., display will not be updated as address lines change.

EXAM (Maintenance Mode) – Used to display Unibus data lines.

1. Press and release the EXAM key.
2. Unibus data lines will be sampled and displayed.

HLT/SS (Maintenance Mode) – Asserts manual clock enable and displays MPC (microprogram counter).

1. Press and release the HLT/SS key.
2. Manual clock enable will be asserted.
3. MPC will be sampled and displayed.

CONT (Maintenance Mode) – Single microsteps the processor through one microstate and displays the MPC.

1. Press and release the CONT key.
2. Manual clock will be pulsed.
3. New MPC will be sampled and displayed.

BOOT (Maintenance Mode) – Boots the M9301. If manual clock enable is asserted, the M9301 routine will not be entered but because the M9301 simulates a power fail the processor will power up through location 24.

1. Press and release the BOOT key.
2. The display is not affected. If manual clock enable is asserted, the MPC is now at the beginning of the power-up sequence. To see the new MPC, use the HLT/SS key.

START (Maintenance Mode) – Drops manual clock enable.

1. Press and release the START key.
2. Manual clock enable is released.
3. MPC will be sampled and displayed.

CLR (Maintenance Mode) – Returns console to console mode operation.

1. Press and release the CLR key.
2. MAINT indicator is off.
3. Processor should halt.
4. Program counter should be displayed.

5 (Maintenance Mode) – Allows the console to take control of the Unibus if a processor is not in the system.

1. Press and release the 5 key.
2. The MAINT indicator will be off (console mode operation now).
3. Console attempts to read the program counter which is not present and therefore the BUS ERR indicator will be on.

7.3 NOTES ON OPERATION

If the single-microstep feature in maintenance mode is to be used, it is preferable that the processor be halted prior to entering maintenance mode, if it is possible. This is because the assertion of manual clock enable, which turns off the processor clock if it is running, cannot be synchronized with the processor clock. Therefore, if the processor is not halted, the clock may be running and the assertion of manual clock enable may cause an erroneous condition to occur.

In order to single-microstep the processor from the beginning of the power-up sequence, the following steps may be used:

1. Halt the processor if possible.
2. Use CNTRL 1 to enter maintenance mode.
3. Use HLT/SS to assert manual clock enable (RUN indicator should come on).
4. Use BOOT to generate a simulated power-fail (will not work if M9301 is not present in the system).

5. Use HLT/SS to display the MPC (microprogram counter) for the first microstep in the power-up routine.
6. Use CONT to single-microstep the processor through the power-up routine. (The new MPC will be displayed at each step.)
7. Unibus address lines and Unibus data (see NOTE below) lines may be examined at any microstep by using DIS AD and EXAM, respectively. Use of these keys does not advance the microprogram. To redisplay the current MPC without advancing the microprogram, use the HLT/SS key.
8. To return from maintenance mode, use the CLR key.
9. To single-microstep through a program, the program counter (R7) must first be loaded with the starting address of the program as in single-instruction stepping the processor prior to entering maintenance mode.

NOTE

Because the data transfer occurs asynchronously with the processor clock, Unibus data will not be displayed on DATI in maintenance mode when using the console with an 11/04 processor. Unibus data on DATO on the 11/04 and both DATI and DATO on the 11/34 will be displayed.

Due to hardware changes, the M8266 module will gate the AMUX lines onto the Unibus when manual clock enable is asserted and a Unibus transaction is not occurring.

CHAPTER 8 KY11-LB MAINTENANCE

8.1 PRELIMINARY CONSIDERATIONS

The following is a guide to locating possible problems on the KY11-LB.

1. Power Switch Failure – If the power switch fails to control the power supply, check cable 7011414-2-2 (BA11-L) at J2 or cable 7011992-0-0 (BA11-K) at Faston tabs TB4 and TB5 on the bezel-mounted board to ensure that cable(s) are securely and correctly installed.
2. If the power switch does turn on the power supply (fans turn) but the DC ON indicator does not come on, check cable 7011992-0-0 (BA11-K) at tabs TB6 and TB7 on the bezel-mounted board.
3. If the four indicators on the left side of the keypad are all on, then the cable 7012214-0-0 connecting the bezel-mounted board to the interface board (M7859) is probably plugged in backward on one end.
4. If no display and none of the four indicators are on, then check cable 7012214-0-0 at J1 on the bezel-mounted board and M7859 board to ensure that it is correctly and securely installed.
5. Note that there should be no cables from either the bezel-mounted board or the M7859 board attached to the backplane. The connection at the backplane is for use by the KY11-LA Operator Console only.
6. If the RUN indicator is on but there is no display and no response from the keypad, the problem is probably at the M7859 Interface module. Check the module to ensure that the microprocessor chip (E18) is securely installed in its socket.
7. If the display works and the console responds to the keypad except for the BOOT key, check that cable 7011413-0-0 is properly connected to the M9301 and to the bezel-mounted board at tabs TB1 and TB2.
8. If the display MPC, single microstep, etc. functions in maintenance mode do not work correctly, check that the cable(s) from J2 and J3 of the M7859 are properly installed.

NOTE

These cables should be installed only for maintenance of the processor. By disconnecting these cables for normal operation, the effect is that the maintenance functions are nonoperative except for the TAKE BUS function.

8.2 M7859 FAILURES

In general, there are two levels of possible failures on the M7859 module. The first level and most difficult to fix is the microprocessor and its support logic which constitutes about 1/3 of the logic. The second level is failures which occur in the peripheral logic constituting the Unibus interface and the display/keypad interface. These are generally easier to troubleshoot.

Generally, a first level failure is readily apparent and will usually be indicated when no display is on and the only indicators on are DC ON and RUN.

A second level failure, although easier to troubleshoot, is not always readily apparent as it may only occur on certain key functions or may be data dependent. A failure on the display/keypad interface would be indicated by odd displays, row, or column failures on the keypad. The Unibus interface can be tested with a good confidence level by loading the switch register with a 123456 data pattern and then reading it back over the Unibus by examining location 777570.

The following is a guide to troubleshooting a failing M7859 module. Generally, the minimum equipment needed is a dual-trace oscilloscope with delayed sweep.

1. Check that 9 V is available at pin 1 of the microprocessor, E18.
2. Check that the clock frequency is $1.0 \text{ MHz} \pm 2\%$ at the test point, TP1. The frequency can be corrected if needed by adjusting the variable resistor at the top of the module.
3. Check that the two clock signals are at E18-15 and E18-16. These clocks should be 500 kHz frequency with nonoverlapping positive pulses of 0.5 ms duration (Figure 8-1).

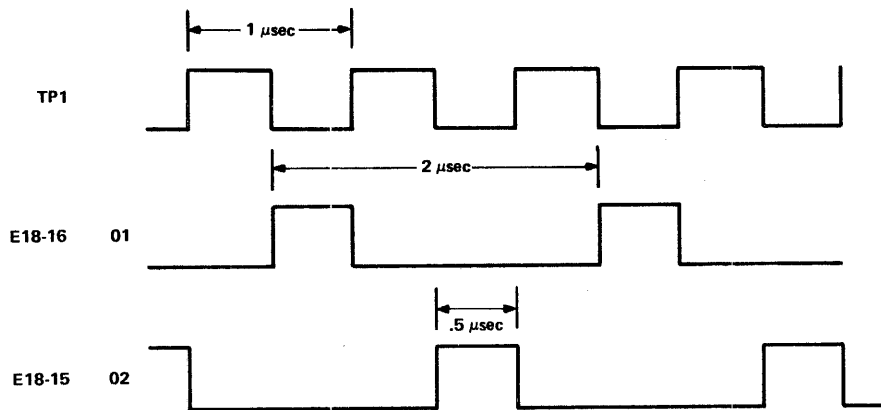

FIG X

11-4858

Figure 8-1 Clock Waveforms

4. Check the signal at E18-18 which should be at logic low. If the signal is high the microprocessor may not have responded to the interrupt request on power-up. If the signal is toggling, this may be indicative of a different class of problems discussed in the following paragraphs.
5. The M7859 logic is such that if the microprocessor encounters a HALT instruction and goes to the STOP state, peripheral logic will automatically try to restart the microprocessor from location 0. Hence, if there are problems in the microprocessor support logic, such as address or data failures, time state decoding failures, etc., the microprocessor will not follow the program and generally encounters a HALT instruction.

The general technique to solve this class of problems is to sync off of the signal STOP L and to use delayed sweep to track addresses backward to find the specific failing address. A quick check of the number of times TS1 L is true between the times that STOP L is true will give an idea of how far into the program the failure occurs. In general the easiest technique is to use the TS3 L signal as a visual key on one channel while using the other channel to probe addresses, data, timing signals, etc.

CHAPTER 9

KY11-LB INSTALLATION

9.1 KY11-LB DESCRIPTION

The KY11-LB is a programmer's console option for both the 11/04 and 11/34 CPUs. It replaces the KY11-LA (operator's console) which is the standard console on 11/04s and 11/34s. The hardware in the KY11-LB option is exactly the same for both the 11/04 and 11/34. The KY11-LB contains a bezel assembly (consisting of a keypad, 7-segment display, indicator lamps, and ON/OFF switch) and a separate SPC quad interface module (M7859). Also, three loose piece cables: two 10-conductor, 45.7 cm (18 inch) long cables and one 20-conductor cable. The two 10-conductor cables are not required for normal console functions and should only be installed when using the console in maintenance mode.

9.2 CPU BOX TYPE

PDP-11/04s and 11/34s are available in both the BA11-L 13.4 cm (5-1/4 inch) box and BA11-K 26.7 cm (10-1/2 inch) box. The difference between these two boxes creates the only difference in installing the KY11-LB. In all cases, the 10-conductor cable, running from the operator's console to the CPU backplane, is not used and must be removed when the KY11-LB is installed. It is extremely important not to connect this cable to the KY11-LB as a short circuit may result.

9.3 CPU DIFFERENCES

The 11/04 is a single-module CPU (M7263). The 11/34 is a 2-module CPU (M7265 and M7266). Maintenance mode connections between KY11-LB and 11/04 are made on the M7263. Maintenance mode connections between KY11-LB and 11/34 are made on the M7266 (Figures 9-1 and 9-2). Note that all figures in this procedure show the M7266 module (11/34). This is done because the hook-up for normal KY11-LB operation is the same for both CPUs.

To identify cables and part numbers for cables, refer to Figure 9-3.

9.4 BA11-L 13.3 CM (5-1/4 INCH BOX) INSTALLATION

1. Remove the operator's console (KY11-LA), noting to which Faston tabs the M9301 is connected. The connections will be to the same tabs on the KY11-LB. The cable from H777 Power Supply plugged into J2 on the KY11-LA will plug into J2 on the KY11-LB. The cable from the CPU backplane to J1 on the KY11-LA must be removed. No connection is made from the backplane to the KY11-LB.

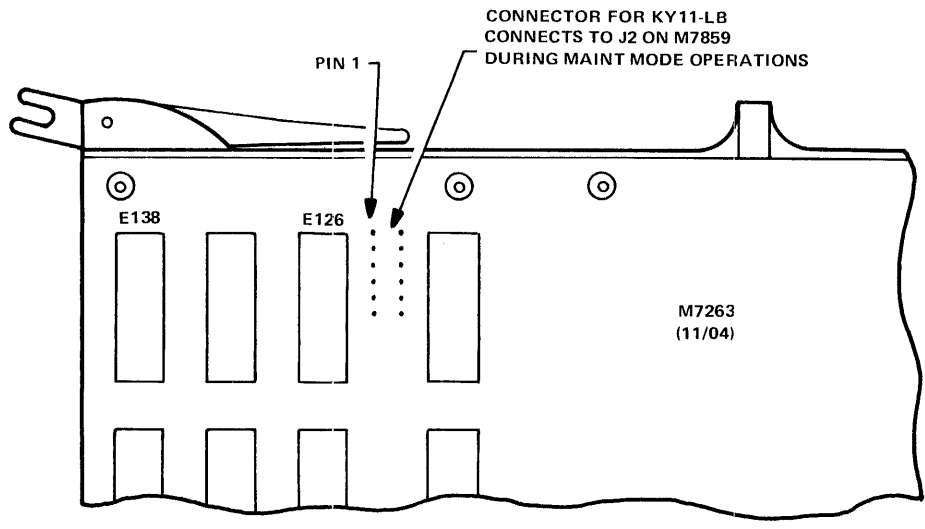

11-4849

Figure 9-1 M7263

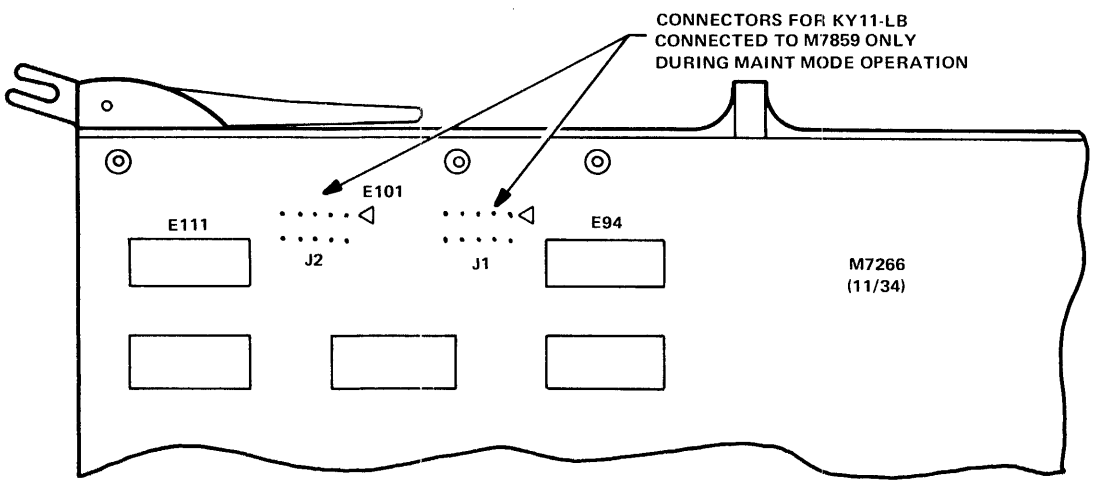

11-4850

Figure 9-2 M7266

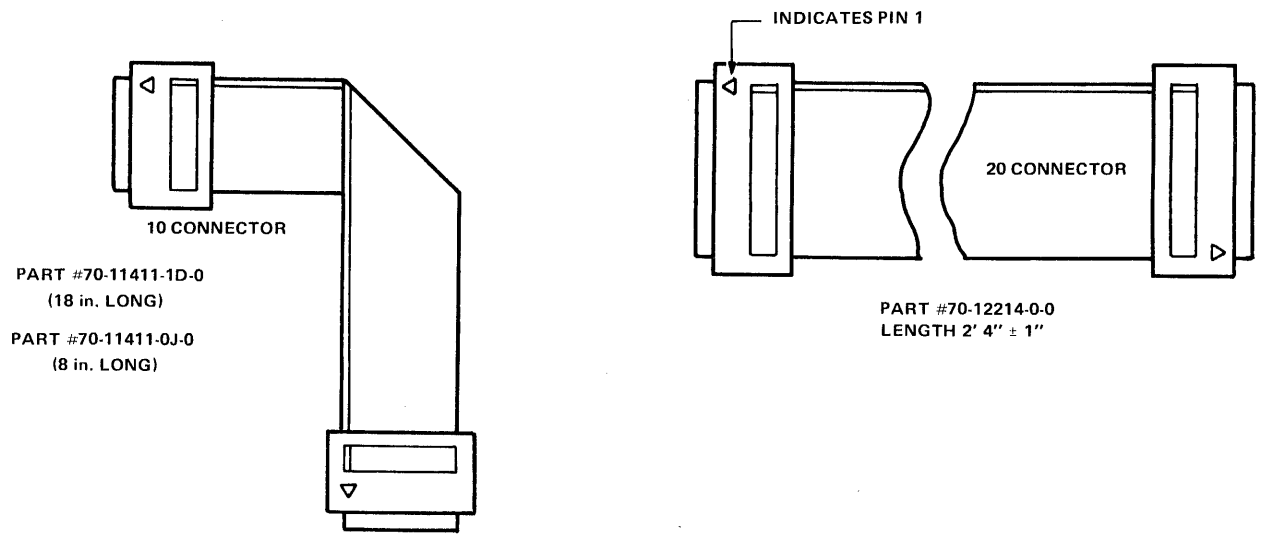

11-4851

Figure 9-3 Cables

2. Install M7859 (KY11-LB interface) in any SPC slot (within CPU backplane) and connect it to the KY11-LB bezel as shown in Figure 9-4.

CONFIGURATION NOTE

The M7859 consumes 2A at +5 V and can only be plugged into the CPU backplane.

WARNING

When doing any reconfiguring of the CPU backplane that might be necessary to make room for the M7859, be sure that the M9302 is never installed in a modified Unibus slot (which results in short circuits).

9.5 BA11-K 26.7 CM (10-1/2 INCH BOX) INSTALLATION

1. Remove the operator's console (KY11-LA), noting to which Faston tabs the M9301 is connected. The connection will be the same tabs on the KY11-LB (Figure 9-5). You will notice that J2 on the operator's console is not used on the BA11-K box. The signals and voltages that come in on this jack in the BA11-L box come in on Faston tabs in the BA11-K box. The cable connecting the CPU backplane to J1 on the operator's console must be removed and no connection from the backplane to the KY11-LB is made.
2. Install M7859 (KY11-LB interface) in any SPC slot (with CPU backplane) and connect to KY11-LB bezel as shown in Figure 9-5.

WARNING

When doing any reconfiguring of the CPU backplane that might be necessary to make room for the M7859, be sure that the M9302 is never installed in a modified Unibus slot (which results in short circuits).

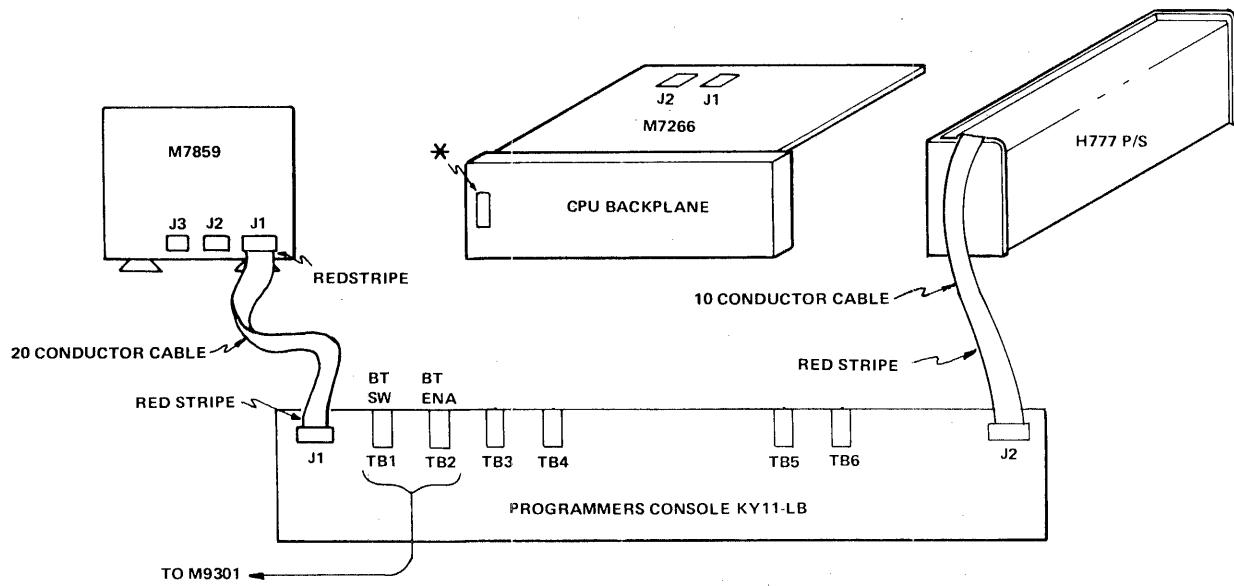
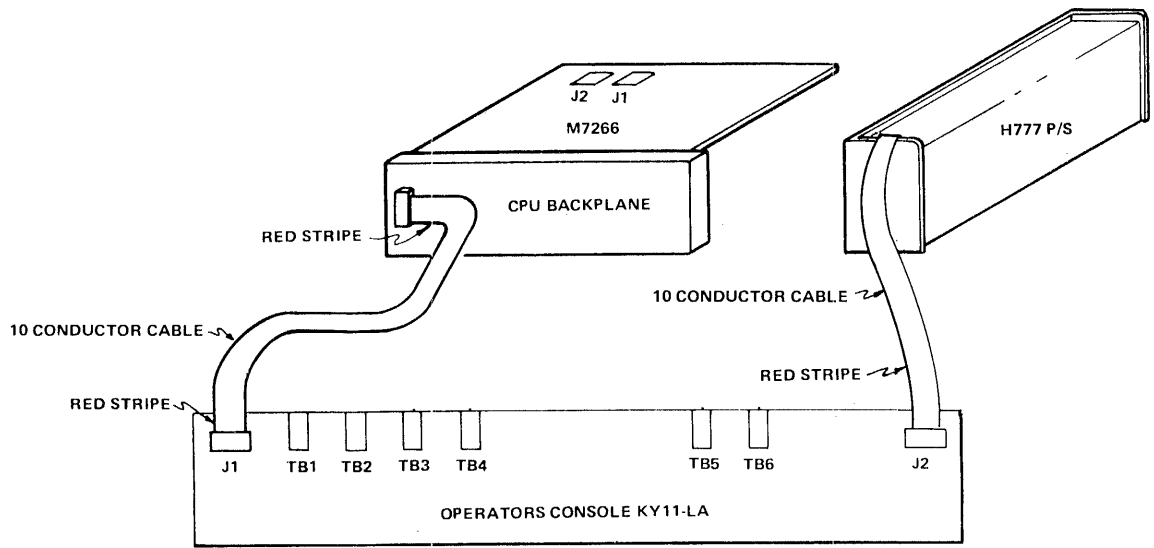

* THIS CONNECTOR NOT USED

11-4847

Figure 9-4 BA11-L

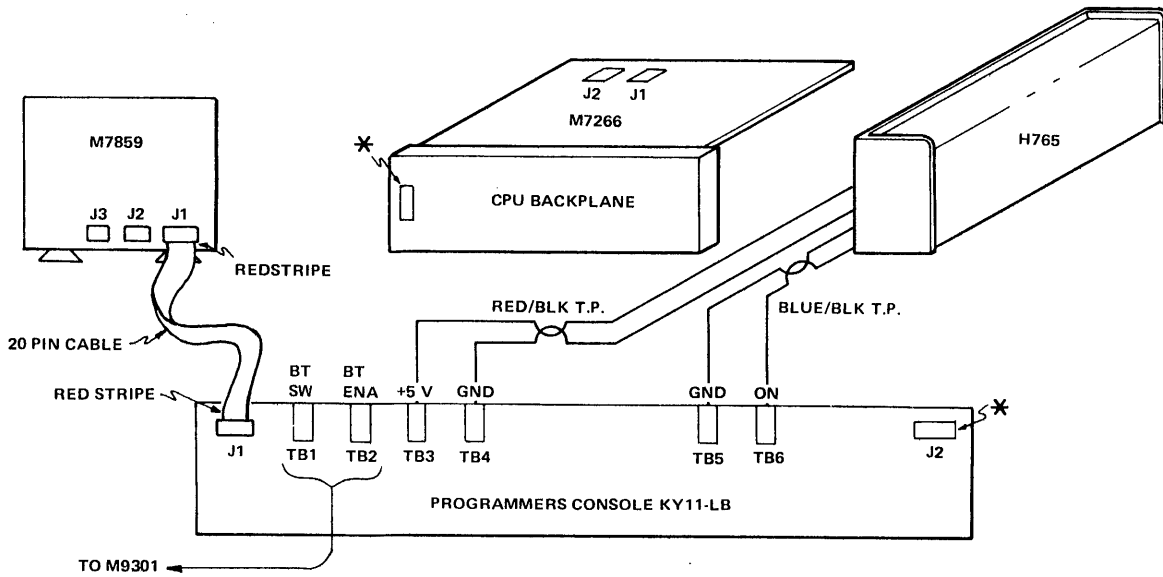
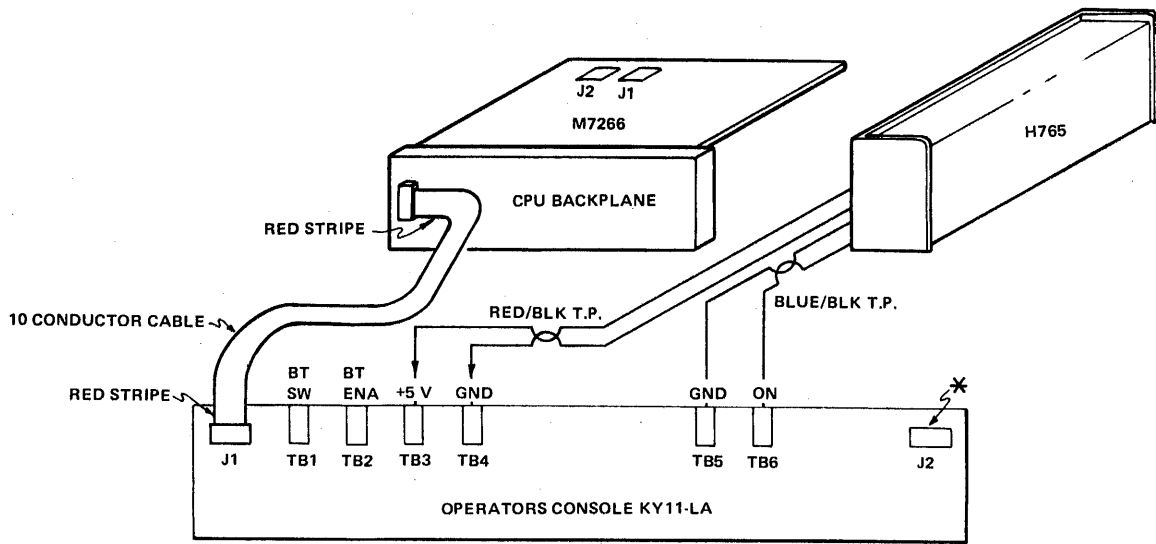

* H775C

11-4848

Figure 9-5 BA11-K

9.6 MAINTENANCE MODE HOOK-UP

To utilize the KY11-LB as a maintenance tool for troubleshooting the CPU or system, additional cable(s) must be installed. The 11/04 requires one additional cable and the 11/34 requires two additional cables.

PDP-11/04 (Maintenance Mode Cabling)

The 11/04 requires only one additional cable for maintenance mode operation. This 10-conductor cable (Part No. 70-11411-1D-0) connects J2 of the M7859 to the unmarked male connector on the M7263 (11/04 CPU). The cable (70-11411-1D-0) has a pointer on each end to indicate pin 1 as shown in Figure 9-3. Install the cable with the pointer on the end of the cable lined up with pin 1 on the CPU module (M7263). Pin 1 on M7263 is called out on Figure 9-1. Points on J2 (M7859) and the cable should also be lined up.

PDP-11/34 (Maintenance Mode Cabling)

The 11/34 requires two additional cables for maintenance mode operation. Both cables are the same and are the same part as is used on the 11/04. See Figure 9-3 for part number.

NOTE

**Maintenance cables for both 11/04 and 11/34 are all
45.7 cm (18 inch) long, 10-conductor cables.**

When installing maintenance cables connect J2 (M7859) to J1 (M7266) and J3 (M7859) to J2 (M7266). The pointers on the cable and board must be matched at both ends of the cables.

APPENDIX A
KY11-LB MICRO-CODE LISTINGS

KY11LB PROGRAM RT-11 MACRO VM02-10 00:13:25 PAGE 1

1 ;MACROS FOR 8008 9/9/74 PAGE 1

2 KY11LB PROGRAM RT-11 MACRO VM02-10 00:13:25 PAGE 7

5 KY11LB PROGRAM RT-11 MACRO VM02-10 00:13:25 PAGE 8

```
1
3      000000      .ASECT
4      000000      .=0
5      .TITLE KY11LB PROGRAM
6      000000      REG0=0
7      000001      REG1=1
8      000002      REG2=2
9      000003      REG3=3
10     000004      REG4=4
11     000005      REG5=5
12     000006      REG6=6
13     000007      REG7=7
14     000003      SRLB=3
15     000004      SRHB=4
16     000405      NUM0=NUM0X
17     000403      NUM2=NUM2X
18     000402      NUM3=NUM3X
19     000401      NUM4=NUM4X
20     000400      NUM5=NUM5X
21     000005      KEYS=5
22     000001      DBHB=1
23     000000      DBLB=0
24 00000 00000 START: RST 10      ;INITIALIZE PC TO 10.
      00000 015
25 00001 00001 BEGIN: LHI 240     ;PRESET H REGISTER TO POINT TO RAM (40) AND TO SET
      00001 056
      00002 240
26
27                                     ;A FLAG (200) TO ENABLE ADDRESS 777570 TO BE DISPLAYED
28 00003                                     ;ON PROGRAMMED HALT.
      00003 066 LLI 20          ;PRESET L REGISTER TO POINT TO RAM.
      00004 020
29 00005 JMP OVER
      00005 104
      00006 013
      00007 000
30 00010 JMP BEGIN
      00010 104
      00011 001
      00012 000
31 00013 OVER: LEI 0             ;ZERO REGISTER E.
      00013 046
      00014 000
32 00015 LA E                   ;ZERO REGISTER A.
      00015 304
33 00016 BEG1: LM A             ;ZERO MEMORY LOCATION (RAM) POINTED TO BY REGISTERS H & L.
      00016 370
34 00017 DC L                   ;DECREMENT REGISTER L.
      00017 061
35 00020 JFS BEG1              ;JUMP BACK UNTIL RAM IS ALL ZEROED.
      00020 120
      00021 016
      00022 000
36 00023 DISP1: CAL DISP15     ;CALL DISPLAY SUBROUTINE,STAYS IN DISPLAY SUBROUTINE
      00023 106
      00024 031
      00025 000
KY11LB PROGRAM RT-11 MACRO VM02-10 00:13:25 PAGE 8+
```

```

37
38 00026          JMP KEYSEV          ;UNTIL A KEY IS DEPRESSED OR A PROGRAM HALT OCCURS.
                                ;RETURNS FROM DISPLAY SUBROUTINE TO
                                00026      104
                                00027      175
                                00030      000
39
40
41
42 00031          DISP15: LA H          ;DISPLAY SUBROUTINE.
                                00031      305
43
44
45 00032          NDI 200              ;LOAD H REGISTER INTO REGISTER A AND MASK
                                ;FOR PROGRAMMED HALT FLAG BIT.
                                ;IF BIT IS NOT SET DO NOT TEST FOR PROGRAM
                                00032      044
                                00033      200
46 00034          JTZ NXT              ;HALT.
                                00034      150
                                00035      052
                                00036      000
47 00037          INP REG5            ;OTHERWISE CHECK FOR HALT BUSY BEING SET.(KY11-LB
                                ;IS ASSERTING BUS BUSY).
                                00037      113
48 00040          NDI 40              ;
                                00040      044
                                00041      040
49 00042          JTZ NXT              ;
                                00042      150
                                00043      052
                                00044      000
50 00045          LHI 40              ;CLEAR FLAG BIT TO PREVENT FURTHER SERVICING
                                00045      056
                                00046      040
51
52 00047          JMP HLT3            ;OF THE HALT BUSY FLAG.
                                ;JUMP TO THE HALT SERVICE ROUTINE.
                                00047      104
                                00050      067
                                00051      010
53 00052          NXT: LCI 6          ;OTHERWISE CONTINUE THE DISPLAY ROUTINE.
                                00052      026
                                00053      006
54
55 00054          LA E                ;LOAD REGISTER C WITH A 6 AS A DISPLAY DIGIT COUNTER.
                                ;MASK OFF THE KEYSERVICE FLAG STORED IN REGISTER
                                00054      304
56 00055          NDI 200            ;E. THIS BIT WHEN SET INDICATES THAT A KEY HAS
                                ;BEEN SERVICED BUT IS STILL DEPRESSED.
                                00055      044
                                00056      200
57 00057          LE A              ;
                                ;PRESET REGISTER D WITH A 1 TO BE USED AS A STROBE BIT.
                                00057      340
58 00060          LDI 1              ;
                                00060      036
                                00061      001
59 00062          DISP2: LAI 0        ;PRESET REGISTER A WITH A ZERO.
                                00062      006
                                00063      000
60 00064          OUT REG0           ;OUTPUTS THE ZERO TO TURN OFF THE DISPLAY.
                                00064      121
61 00065          LLI 0              ;PRESET MEMORY POINTER REGISTER L TO ZERO
                                00065      066
KY11LB PROGRAM RT-11 MACRO VM02-10 00:13:25 PAGE 8+

```

00066	000		
62			;TO PICK UP THE CONTENTS OF THE FIRST LOCATION IN RAM.
63	00067	LA M	;GET THE CONTENTS OF THE FIRST LOCATION IN RAM.
	00067	307	
64	00070	NDI 7	;MASK OFF THE LOWEST 3 BITS AND
	00070	044	
	00071	007	
65	00072	OUT REG1	;OUTPUT TO THE DISPLAY.
	00072	123	
66	00073	LA D	;LOAD THE D REGISTER INTO A REGISTER AND OUTPUT IT
	00073	303	
67	00074	OUT REG0	;TO TURN ON THE PROPER DIGIT OF THE DISPLAY,THIS
	00074	121	
68			;WILL ALSO SELECT A PARTICULAR COLUMN OF THE KEYPAD
69			;TO BE READ BACK LATER.
70	00075	LA D	;GET THE CONTENTS OF REGISTER D AND ROTATE LEFT
	00075	303	
71	00076	RLC	;TO SET UP TO TURN ON THE NEXT DIGIT.
	00076	002	
72	00077	LD A	
	00077	330	
73	00100	LBI 3	;LOAD REGISTER B WITH A 3 TO PASS TO THE SHIFT
	00100	016	
	00101	003	
74	00102	CAL SHFT1	;SUBROUTINE WHICH WILL SHIFT THE DIPLAY DATA 3
	00102	106	
	00103	335	
	00104	000	
75			;POSITIONS.
76	00105	LA C	;ON RETURN FROM SHIFT SUBROUTINE, LOAD REGISTER
	00105	302	
77	00106	CPI 1	;A WITH REGISTER C AND CHECK FOR A 1 TO SEE IF LAST
	00106	074	
	00107	001	
78			;DIGIT IS BEING DISPLAYED.
79	00110	JTZ DISP45	;IF LAST DIGIT IS BEING DISPLAYED JUMP OVER KEYPAD
	00110	150	
	00111	137	
	00112	000	
80			;INPUT ROUTINE .
81	00113	ADI 1	;OTHERWISE ADD A 1 TO REGISTER A (CONTAINING REGISTER C)
	00113	004	
	00114	001	
82	00115	LL A	;AND LOAD MEMORY POINTER TO POINT TO KEYPAD IMAGE
	00115	360	
83			;AREA OF THE RAM.
84	00116	INP KEYS	;INPUT A COLUMN FROM THE KEYPAD AND
	00116	113	
85	00117	NDI 17	;MASK FOR SIGNIFIGANT BITS.
	00117	044	
	00120	017	
86	00121	JTZ DISP4	;CHECK FOR NO KEYS DEPRESSED,OTEHERWISE
	00121	150	
	00122	136	
	00123	000	
87	00124	XR M	;COMPARE AGAINST THE CONTENTS OR THE RAM(KEYPAD IMAGE)
	00124	257	

KY11LB PROGRAM RT-11 MACRO VM02-10 00:13:25 PAGE 84

```

88 00125          JTZ DISP3      ;TO CHECK THAT THE KEYPAD IS STABLE.
    00125      150
    00126      132
    00127      000
89 00130          IN E           ;INCREMENT REGISTER E BY THREE IF THE KEY IS DEPRESSED.
    00130      040
90 00131          IN E           ;DOES NOT MATCH THE RAM CONTENTS. REGISTER E WILL
    00131      040
91 00132          DISP3: IN E     ;BE INCREMENTED BY ONE IF THERE IS A MATCH.
    00132      040
92 00133          INF KEYS       ;INPUT THE COLUMN OF KEYPAD AGAIN AND
    00133      113
93 00134          NDI 17        ;MASK FOR SIGNIFICANT BITS.
    00134      044
    00135      017
94 00136          DISP4: LM A     ;STORE IN KEYPAD IMAGE AREA OF RAM FOR NEXT TIME.
    00136      370
95 00137          DISP45: DC C   ;DECREMENT THE DISPLAY COUNTER AND
    00137      021
96 00140          JFZ DISP2      ;IF NOT DONE JUMP BACK AND DISPLAY NEXT DIGIT.
    00140      110
    00141      062
    00142      000
97 00143          LAI 0         ;IF ALL DIGITS HAVE BEEN DISPLAYED AND KEYPAD HAS
    00143      006
    00144      000
98 00145          OUT REGO      ;BEEN READ, LOAD REGISTER A WITH A ZERO AND OUTPUT
    00145      121
99                                     ;TO TURN DISPLAY OFF.
100 0146          LBI 6         ;LOAD REGISTER B WITH A 6 TO BE PASSED TO THE SHIFT
    0146      016
    0147      006
101 0150          CAL SHFT1     ;SUBROUTINE. SIX MORE SHIFTS ARE NECESSARY TO
    0150      106
    0151      335
    0152      000
102                                     ;FINISH SHIFTING AN 18 BIT NUMBER (SIX DIGITS)
103                                     ;THROUGH 24 BITS OF MEMORY IN THE RAM (3 WORDS).
104 0153          LA E         ;GET THE CONTENTS OF REGISTER E AND CHECK
    0153      304
105 0154          CPI 200
    0154      074
    0155      200
106 0156          JFZ DISP5     ;IF ONLY KEYSERVICE FLAG IS SET (KEY NO LONGER DEPRESSED)
    0156      110
    0157      163
    0160      000
107 0161          LEI 0         ;IF NO KEYS ARE DEPRESSED KEYSERVICE FLAG IS CLEARED.
    0161      046
    0162      000
108 0163          DISP5: LA E   ; OTHERWISE, CHECK REGISTER E FOR A 1 OR A 2
    0163      304
109 0164          CPI 1        ;(1 OR 2 KEYS ARE DEPRESSED AND ARE STABLE)
    0164      074
    0165      001
110 0166          RTZ          ;AND IF TRUE RETURN FROM DISPLAY SUBROUTINE TO SERVICE
    0166      053
KY111LB PROGRAM RT-11 MACRO VM02-10 00:13:25 PAGE 8+

```

```

111 0167          CPI 2          ;THE KEY BEING DEPRESSED.
      0167      074
      0170      002
112 0171          RTZ
      0171      053
113 0172          JMP DISP15     ;STAY IN DISPLAY SUBROUTINE.
      0172      104
      0173      031
      0174      000
114
115              ;KEY SERVICE ROUTINE.
116              ;THIS ROUTINE DECODES THE CONSOLE MODE KEYS
117              ;TO JUMP TO THE PROPER ROUTINE TO PERFORM
118              ;THE PARTICULAR FUNCTION ASSOCIATED
119              ;WITH EACH KEY.
120 0175          KEYSEV: LBI 0    ;RESET REGISTER B TO ZERO.
      0175      016
      0176      000
121 0177          LEI 200        ;SET KEYSERVICE FLAG TO INDICATE THAT KEY HAS BEEN SERVICED.
      0177      046
      0200      200
122 0201          LLI 3         ;SET UP MEMORY POINTER TO THE KEYPAD IMAGE AREA.
      0201      066
      0202      003
123 0203          LA M          ;GET THE FIRST COLUMN OF KEYS FROM THE KEYPAD IMAGE
      0203      307
124 0204          RAR           ;AREA OF RAM. ROTATE THE VALUE OF THE FIRST KEY IN THAT
125 0205          JTC DISPAD    ;COLUMN INTO THE CARRY BIT AND JUMP TO THE SERVICE
      0205      140
      0206      344
      0207      010
126 0210          RAR           ;ROUTINE FOR THAT KEY IF THE C BIT IS SET. OTHERWISE
      0210      032
127 0211          JTC LAD1     ;ROTATE IN THE VALUE OF THE NEXT KEY AND SO ON UNTIL
      0211      140
      0212      305
      0213      010
128 0214          RAR           ;THE WHOLE COLUMN HAS BEEN CHECKED.
      0214      032
129 0215          JTC LSR1
      0215      140
      0216      230
      0217      010
130 0220          RAR
      0220      032
131 0221          JTC CLR1
      0221      140
      0222      327
      0223      010
132 0224          IN L         ;AFTER WHOLE COLUMN HAS BEEN CHECKED INCREMENT THE
      0224      060
133 0225          LA M          ;MEMORY POINTER AND GET THE VALUES OF THE NEXT COLUMN
      0225      307
134 0226          RAR           ;OF KEYS FROM THE KEYPAD IMAGE AREA. DECODE THESE
      0226      032
135 0227          JTC NUM7     ;KEYS IN THE SAME MANNER.
KY11LB PROGRAM RT-11 MACRO VM02-10 00:13:25 PAGE 8+

```

	0227	140	
	0230	220	
	0231	011	
136	0232		RAR
	0232	032	
137	0233		JTC NUM4
	0233	140	
	0234	001	
	0235	001	
138	0236		RAR
	0236	032	
139	0237		JTC NUM1
	0237	140	
	0240	371	
	0241	010	
140	0242		RAR
	0242	032	
141	0243		JTC NUM0
	0243	140	
	0244	005	
	0245	001	
142	0246		IN L
	0246	060	
143	0247		LA M
	0247	307	
144	0250		RAR
	0250	032	
145	0251		JTC EXAM1
	0251	140	
	0252	107	
	0253	001	
146	0254		RAR
	0254	032	
147	0255		JTC NUM5
	0255	140	
	0256	000	
	0257	001	
148	0260		RAR
	0260	032	
149	0261		JTC NUM2
	0261	140	
	0262	003	
	0263	001	
150	0264		RAR
	0264	032	
151	0265		JTC INIT1
	0265	140	
	0266	111	
	0267	010	
152	0270		IN L
	0270	060	
153	0271		LA M
	0271	307	
154	0272		RAR
	0272	032	
155	0273		JTC DEP1
	0273	140	

KY111LB PROGRAM RT-11 MACRO VM02-10 00:13:25 PAGE 8+

0274	271		
0275	001		
156 0276		RAR	
0276	032		
157 0277		JTC NUM6	
0277	140		
0300	253		
0301	011		
158 0302		RAR	
0302	032		
159 0303		JTC NUM3	
0303	140		
0304	002		
0305	001		
160 0306		IN L	‡NOTE THAT THE CNTRL KEY IS NOT DECODED HERE
0306	060		
161 0307		LA M	‡BECAUSE IT IS USED IN CONJUNCTION WITH KEYS YET TO
0307	307		
162 0310		RAR	‡BE DECODED.
0310	032		
163 0311		JTC HLT1	
0311	140		
0312	023		
0313	010		
164 0314		RAR	
0314	032		
165 0315		JTC CONT1	
0315	140		
0316	212		
0317	010		
166 0320		RAR	
0320	032		
167 0321		JTC BOOT1	
0321	140		
0322	063		
0323	001		
168 0324		RAR	
0324	032		
169 0325		JTC STRT1	
0325	140		
0326	150		
0327	010		
170 0330		LEI 0	‡IT IS ASSUMED THAT THE CNTRL KEY HAS BEEN DEPRESSED
0330	046		
0331	000		
171 0332		JMP DISP1	‡SINCE ALL OTHER KEYS HAVE BEEN DECODED. KEYSERVICE
0332	104		
0333	023		
0334	000		
172			‡FLAG IS CLEARED SO THAT A SECOND KEY MAY BE
173			‡DECODED IN CONJUNCTION WITH THE CNTRL KEY.
174			
175			
176			‡SHIFT SUBROUTINE.
177			‡THIS SUBROUTINE IS USED TO SHIFT THE DISPLAY
178			‡DATA AREA OF THE RAM (FIRST 3 LOCATIONS)
179			‡THE NUMBER OF BIT POSITIONS PASSED THROUGH
KY111LB PROGRAM RT-11 MACRO VM02-10			00:13:25 PAGE 8+

```

180                                     ;REGISTER B.
181 0335          SHFT1: LLI 3
      0335          066
      0336          003
182 0337          LAI 0          ;SET UP MEMORY POINTER TO THE MOST SIGNIFICANT WORD
      0337          006
      0340          000
183 0341          RAR          ;PLUS ONE. ZERO REGISTER A AND ROTATE TO CLEAR THE
      0341          032
184 0342          DC L          ;CARRY BIT.
      0342          061
185 0343          SHFT2: LA M          ;DECREMENT THE MEMORY POINTER AND GET THE FIRST
      0343          307
186 0344          RAR          ;WORD TO BE SHIFTED.
      0344          032
187 0345          LM A          ;ROTATE TO THE RIGHT SAVING THE LSB IN THE C BIT.
      0345          370
188 0346          DC L          ;RESTORE TO MEMORY THE SHIFTED VALUE.
      0346          061
189 0347          JFS SHFT2          ;DECREMENT MEMORY POINTER TO NEXT WORD AND
      0347          120
      0350          343
      0351          000
190 0352          LLI 2          ;IF NOT DONE JUMP BACK.
      0352          066
      0353          002
191 0354          LA M          ;THE LSB OF THE LEAST SIGNIFICANT WORD IS NOW IN THE
      0354          307
192 0355          RAL          ;C BIT BUT SHOULD BE IN MSB OF MOST SIGNIFICANT WORD.
      0355          022
193 0356          RRC          ;MEMORY POINTER IS RESET TO MOST SIGNIFICANT WORD
      0356          012
194 0357          LM A          ;AND C BIT SHIFTED INTO LSB. THE WORD
      0357          370
195 0360          DC B          ;IS THEN ROTATED TO PUT LSB INTO MSB POSITION.
      0360          011
196 0361          JFZ SHFT1          ;SHIFT COUNTER IS DECREMENTED AND IF DONE RETURN
      0361          110
      0362          335
      0363          000
197 0364          RET          ;FROM SUBROUTINE.
      0364          007
198
199
200                                     ;MODE TEST SUBROUTINE.
201                                     ;THIS SUBROUTINE IS USED BY VARIOUS KEY
202                                     ;SERVICE ROUTINES TO CHECK IF THE CNTRL KEY
203                                     ;HAS BEEN DEPRESSED PRIOR TO SERVICING THOSE
204                                     ;KEYS WHICH REQUIRE THE CNTRL TO
205                                     ;BE USED.
206 0365          MDTST: LLI 6          ;SET MEMORY POINTER TO KEYPAD IMAGE AREA AND
      0365          066
      0366          006
207 0367          LA M          ;GET WORD CONTAINING THE VALUE OF THE CNTRL KEY.
      0367          307
208 0370          NDI 10          ;TEST FOR THE CNTRL KEY AND IF NOT DEPRESSED
      0370          044
KY111LB PROGRAM RT-11 MACRO VM02-10 00:13:25 PAGE 84

```

```

0371 010
209 0372 JTZ DISPI ;RETURN TO DISPLAY ROUTINE, OTHERWISE RETURN TO SERVICE
0372 150
0373 023
0374 000
210 0375 RET ;ROUTINE WHICH CALLED.
0375 007
211
212
213 ;NUMERIC ROUTINE.
214 ;THIS ROUTINE GENERATES THE PROPER 3 BIT
215 ;DIGIT WHEN A NUMERIC KEY IS DEPRESSED AND
216 ;LEFT SHIFTS IT INTO THE TEMPORARY AREA
217 ;OF THE RAM.
218 0376 NUM7X: IN B ;INCREMENT THE B REGISTER THE CORRECT NUMBER
0376 010
219 0377 NUM6X: IN B ;OF TIMES DEPENDING UPON THE NUMERIC KEY DEPRESSED.
0377 010
220 0400 NUM5X: IN B ;NOTE THE B REGISTER WAS CLEARED AT THE BEGINNING
0400 010
221 0401 NUM4X: IN B ;OF THE KEY SERVICE ROUTINE.
0401 010
222 0402 NUM3X: IN B
0402 010
223 0403 NUM2X: IN B
0403 010
224 0404 NUM1X: IN B
0404 010
225 0405 NUM0X: LCI 3 ;PRESET REGISTER C WITH A 3 AS A SHIFT COUNTER.
0405 024
0406 003
226 0407 NUMX: LLI 10 ;SET THE MEMORY POINTER TO THE TEMPORARY AREA IN THE RAM.
0407 066
0410 010
227 0411 LA M ;ROTATE THE THREE WORDS OF THE TEMPORARY AREA ONE
0411 307
228 0412 RAL ;BIT AT A TIME, THREE TIMES AROUND SO THAT ALL THREE WORDS
0412 022
229 0413 LM A ;HAVE BEEN SHIFTED THREE TIMES.
0413 370
230 0414 IN L
0414 060
231 0415 LA M
0415 307
232 0416 RAL
0416 022
233 0417 LM A
0417 370
234 0420 IN L
0420 060
235 0421 LA M
0421 307
236 0422 RAL
0422 022
237 0423 LM A
0423 370
238 0424 DC C
KY11LB PROGRAM RT-11 MACRO VM02-10 00:13:25 PAGE 8+

```

```

0424 021
239 0425 JFZ NUMX
0425 110
0426 007
0427 001
240 0430 LLI 10 ;RESET MEMORY POINTER TO LEAST SIGNIFICANT WORD.
0430 066
0431 010
241 0432 LA M ;GET THE WORD AND ZERO THE LEAST THREE SIGNIFICANT
0432 307 ;BITS.
242 0433 NDI 370
0433 044
0434 370
243 0435 AD B ;ADD IN THE THREE BIT DIGIT FROM REGISTER B AND
0435 201 ;RESTORE IN MEMORY.
244 0436 LM A
0436 370
245 0437 LAI 0 ;CLEAR DISPLAY INDICATORS.
0437 006
0440 000
246 0441 OUT REG6
0441 135
247
248
249 ;MOVE ROUTINE.
250 ;THIS ROUTINE IS USED TO MOVE THE TEMPORARY
251 ;AREA OR THE SWITCH REGISTER IMAGE AREA OF
252 ;THE RAM TO THE DISPLAY AREA OF THE RAM.
253 0442 MOV1: LLI 10 ;SET UP MEMORY POINTER TO TEMPORARY AREA OF RAM.
0442 066
0443 010
254 0444 MOV2: LB M ;LOAD THE NEXT THREE WORDS FROM RAM INTO REGISTERS
0444 317 ;B, C, AND D.
255 0445 IN L
0445 060
256 0446 LC M
0446 327
257 0447 IN L
0447 060
258 0450 LD M
0450 337
259 0451 LLI 0 ;RESET MEMORY POINTER TO THE DISPLAY AREA OF THE
0451 066 ;RAM AND LOAD REGISTERS B, C, AND D BACK INTO MEMORY.
0452 000
260 0453 LM B
0453 371
261 0454 IN L
0454 060
262 0455 LM C
0455 372
263 0456 IN L
0456 060
264 0457 LM D
0457 373
265 0460 JMP DISP1 ;GO BACK TO DISPLAY ROUTINE.
0460 104
0461 023

```

```

0462 000
266
267
268
269
270
271 0463          BOOT1: CAL MDTST
      0463      106
      0464      365
      0465      000
272 0466          CAL HLTST
      0466      106
      0467      362
      0470      010
273 0471          LHI 240
      0471      056
      0472      240
274
275 0473          LAI 200
      0473      006
      0474      200
276 0475          OUT REG6
      0475      135
277 0476          LAI 0
      0476      006
      0477      000
278 0500          OUT REG6
      0500      135
279 0501          CAL TIMER
      0501      106
      0502      133
      0503      010
280 0504          JMP SRDISP
      0504      104
      0505      261
      0506      010
281
282
283
284
285
286 0507          EXAM1: CAL HLTST
      0507      106
      0510      362
      0511      010
287 0512          LLI 15
      0512      066
      0513      015
288 0514          LA M
      0514      307
289 0515          NDI 200
      0515      044
      0516      200
290 0517          JTZ EXAM2
      0517      150
      0520      130
      0521      001
KY11LB PROGRAM RT-11 MACRO VM02-10 00:13:25 PAGE 8+

```

```

291 0522          CAL GPRT1      #BEING USED, CHECK TO SEE IF IT SHOULD BE INCREMENTED
    0522      106
    0523      174
    0524      001
292 0525          CAL INCAD      #BY ONE (GENERAL REGISTER) OR BY TWO.
    0525      106
    0526      151
    0527      001
293 0530          EXAM2: CAL BADLD #LOADS BUS ADDRESS POINTER (RAM) INTO THE UNIBUS
    0530      106
    0531      344
    0532      001
294 0533          LLI 15        #ADDRESS REGISTER.
    0533      066
    0534      015
295 0535          LA M          #MASK OFF THE TWO DATA BITS AND SET THE EXAM FLAG
    0535      307
296 0536          NDI 3         #(200 IN LOCATION 15).
    0536      044
    0537      003
297 0540          ORI 200
    0540      064
    0541      200
298 0542          LM A
    0542      370
299 0543          CAL DATI1     #CALL THE DATI ROUTINE AND JUMP TO THE MOVE ROUTINE
    0543      106
    0544      230
    0545      001
300 0546          JMP MOV1      #TO DISPLAY THE NEW DATA.
    0546      104
    0547      042
    0550      001
301
302
303
304
305
306 0551          INCAD: LLI 13  #INCREMENT ADDRESS SUBROUTINE.
    0551      066                #THIS SUBROUTINE INCREMENTS THE UNIBUS ADDRESS
    0552      013                #POINTER IN THE RAM BY 1.
    #ADDS A 1 TO THE LEAST SIGNIFIANT WORD
307 0553          LA M          #OF THE UNIBUS ADDRESS POINTER (LOCATION 13)
    0553      307
308 0554          ADI 1         #AND THEN ADDS THE CARRY BIT INTO THE NEXT TWO
    0554      004                #WORDS. THE TWO LSB'S IN THE LAST WORD ARE MASKED
    0555      001                #AS SIGNIFIANT (18 BIT ADDRESS).
309 0556          LM A          #WORDS. THE TWO LSB'S IN THE LAST WORD ARE MASKED
    0556      370
310 0557          IN L         #AS SIGNIFIANT (18 BIT ADDRESS).
    0557      060
311 0560          LAI 0
    0560      006
    0561      000
312 0562          AC M
    0562      217
313 0563          LM A
    0563      370
KY11LB PROGRAM RT-11 MACRO VM02-10 00:13:25 PAGE 8+

```

```

314 0564          IN L
      0564      060
315 0565          LAI 0
      0565      006
      0566      000
316 0567          AC M
      0567      217
317 0570          NDI 3
      0570      044
      0571      003
318 0572          LM A
      0572      370
319 0573          RET
      0573      007
320
321
322
323
324
325
326
327
328
329
330 0574          GPRT1: LA M
      0574      307
331 0575          NDI 3
      0575      044
      0576      003
332 0577          CPI 3          ;ARE ADDRESS BITS 17 AND 16 ONES?
      0577      074
      0600      003
333 0601          JFZ GPRT2      ;NO.
      0601      110
      0602      224
      0603      001
334 0604          DC L          ;YES.
      0604      061
335 0605          LA M
      0605      307
336 0606          CPI 377      ;ARE ADDRESS BITS 15 THRU 8 ONES?
      0606      074
      0607      377
337 0610          JFZ GPRT2      ;NO.
      0610      110
      0611      224
      0612      001
338 0613          DC L          ;YES.
      0613      061
339 0614          LA M
      0614      307
340 0615          NDI 360      ;ARE ADDRESS BITS 7 AND 6 ONES AND
      0615      044
      0616      360
341 0617          CPI 300      ;BITS 5 AND 4 ZEROES?
      0617      074
      0620      300
KY11LB PROGRAM RT-11 MACRO VM02-10 00:13:25 PAGE 8+

```

```

342 0621          JTZ GPRT3      #YES.
      0621      150
      0622      227
      0623      001
343 0624          GPRT2: CAL INCD #NO. INCREMENT ADDRESS BY ONE.
      0624      106
      0625      151
      0626      001
344 0627          GPRT3: RET
      0627      007
345
346
347
348
349
350
351
352 0630          DATI1: LLI 10   #DATI SUBROUTINE.
      0630      066              #THIS SUBROUTINE PERFORMS A DATI ON THE
      0631      010              #UNIBUS ADDRESS POINTED TO BY THE UNIBUS ADDRESS
      0632      006              #REGISTER. THE RECEIVED DATA IS LOADED INTO
      0633      010              #THE TEMPORARY AREA IN RAM.
      0634      133              #SET UP MEMORY POINTER TO TEMPORARY.
353 0632          LAI 10         #SET BUS MSYN BIT.
      0632      006
      0633      010
354 0634          OUT REG5
      0634      133
355 0635          INP REG5      #HAS BUS SSSYN BEEN RETURNED?
      0635      113
356 0636          NDI 20
      0636      044
      0637      020
357 0640          JTZ BUSERR    #NO, REPORT BUS ERROR.
      0640      150
      0641      257
      0642      001
358 0643          DATI2: INP DBLB #YES, PROCEED.  GET LOW BYTE OF UNIBUS
      0643      101
      0644      370
359 0644          LM A          #DATA AND STORE IN MEMORY.
      0644      370
360 0645          IN L
      0645      060
361 0646          INP DBHB     #GET HIGH BYTE OF UNIBUS DATA AND
      0646      103              #STORE IN MEMORY.
362 0647          LM A
      0647      370
363 0650          IN L
      0650      060
364 0651          LAI 0
      0651      006
      0652      000
365 0653          LM A          #ZERO LAST WORD OF TEMPORARY.
      0653      370
366 0654          OUT REG5     #CLEAR BUS MSYN BIT.
      0654      133
367 0655          OUT REG2     #DROP UNIBUS ADDRESS LINES.
      0655      125
368 0656          RET
      0656      007
KY111LB PROGRAM RT-11 MACRO VM02-10 00:13:25 PAGE 8+

```

```

369
370
371
372
373
374 0657      BUSERR: LAI 20
      0657      006
      0660      020
375 0661      OUT REG6      ;SET BUS ERROR INDICTOR.
      0661      135
376 0662      LAI 0
      0662      006
      0663      000
377 0664      OUT REG5      ;DROP BUS MSYN.
      0664      133
378 0665      OUT REG2      ;DROP UNIBUS ADDRESS LINES.
      0665      125
379 0666      JMP CLR2      ;GO CLEAR THE DISPLAY.
      0666      104
      0667      332
      0670      010
380
381
382
383
384 0671      DEF1:  CAL HLTST
      0671      106
      0672      362
      0673      010
385 0674      LAI 0
      0674      006
      0675      000
386 0676      OUT REG6      ;CLEAR THE INDICATORS.
      0676      135
387 0677      LLI 15      ;SET UP MEMORY POINTER AND CHECK DEPOSIT FLAG.
      0677      066
      0700      015
388 0701      LA M
      0701      307
389 0702      NDI 100      ;FIRST DEPOSIT?
      0702      044
      0703      100
390 0704      JTZ DEP2      ;YES.
      0704      150
      0705      315
      0706      001
391 0707      CAL GPRT1      ;NO. CHECK FOR GENERAL REGISTER.
      0707      106
      0710      174
      0711      001
392 0712      CAL INCAD      ;INCREMENT UNIBUS ADDRESS POINTER.
      0712      106
      0713      151
      0714      001
393 0715      DEF2:  LA M
      0715      307
394 0716      ORI 10      ;SET THE BUS C1 BIT (IN RAM) TO DO A DATO.
KY11LB PROGRAM RT-11 MACRO VM02-10 00:13:25 PAGE 8+

```

0716	064		
0717	010		
395 0720		LM A	
0720	370		
396 0721		CAL BADLD	‡LOAD THE UNIBUS ADDRESS REGISTER.
0721	106		
0722	344		
0723	001		
397 0724		LLI 15	
0724	066		
0725	015		
398 0726		LA M	
0726	307		
399 0727		NDI 3	
0727	044		
0730	003		
400 0731		ORI 100	‡SET THE DEPOSIT FLAG.
0731	064		
0732	100		
401 0733		LM A	
0733	370		
402 0734		LLI 10	‡RESET MEMORY POINTER TO TEMPORARY AREA OF RAM.
0734	066		
0735	010		
403 0736		CAL DATD1	‡CALL THE DATO SUBROUTINE USING THE TEMPORARY AREA
0736	106		
0737	361		
0740	001		
404 0741		JMP MOV1	‡AS DATA. DISPLAY TEMPORARY AREA.
0741	104		
0742	042		
0743	001		
405			
406			
407			‡UNIBUS ADDRESS REGISTER LOAD SUBROUTINE.
408			‡THIS SUBROUTINE LOADS THE UNIBUS ADDRESS
409			‡POINTER FROM RAM INTO THE UNIBUS ADDRESS
410			‡REGISTER AND ENABLES THE REGISTER ONTO
411			‡THE UNIBUS.
412 0744		BADLD: LLI 13	‡SET UP MEMORY POINTER TO UNIBUS ADDRESS POINTER.
0744	066		
0745	013		
413 0746		LA M	
0746	307		
414 0747		OUT REG0	‡MOVE FIRST WORD TO UNIBUS ADDRESS REGISTER.
0747	121		
415 0750		IN L	
0750	060		
416 0751		LA M	
0751	307		
417 0752		OUT REG1	‡MOVE NEXT WORD TO REGISTER.
0752	123		
418 0753		IN L	
0753	060		
419 0754		LA M	
0754	307		
420 0755		ORI 4	‡SET THE ENABLE BIT.

KY11LB PROGRAM RT-11 MACRO VM02-10 00:13:25 PAGE 8+

	0755	064		
	0756	004		
421	0757		OUT REG2	‡LOAD LAST PART OF REGISTER.
	0757	125		
422	0760		RET	
	0760	007		
423				
424				
425				‡DATO SUBROUTINE.
426				‡THIS SUBROUTINE PERFORMS THE DATO
427				‡SEQUENCE FOR DEPOSIT AND START KEY FUNCTIONS.
428	0761		DAT01: LA M	‡GET FIRST WORD FROM MEMORY(FROM TEMPORARY ON DEPOSITS
	0761	307		
429	0762		OUT SRLB	‡AND UNIBUS ADDRESS POINTER ON STARTS) AND LOAD
	0762	127		
430	0763		IN L	‡LOW BYTE OF SWITCH REGISTER.
	0763	060		
431	0764		LA M	‡GET SECOND WORD OF DATA AND LOAD INTO
	0764	307		
432	0765		OUT SRHB	‡HIGH BYTE OF SWITCH REGISTER.
	0765	131		
433	0766		LAI 4	‡SET BIT TO ENABLE SWITCH REGISTER ONTO
	0766	006		
	0767	004		
434	0770		OUT REG5	‡THE UNIBUS.
	0770	133		
435	0771		LAI 14	
	0771	006		
	0772	014		
436	0773		OUT REG5	‡ASSERT BUS MSYN.
	0773	133		
437	0774		INP REG5	‡BUS SSYN RETURNED?
	0774	113		
438	0775		JMP MEM2	‡JUMP OVER ROM MEMORY BOUNDARY.
	0775	104		
	0776	001		
	0777	010		
439	1000		NOF	
	1000	300		
440	1001		MEM2: NDI 20	
	1001	044		
	1002	020		
441	1003		JTZ BUSERR	‡NO.
	1003	150		
	1004	257		
	1005	001		
442	1006		LAI 4	‡YES.
	1006	006		
	1007	004		
443	1010		OUT REG5	‡DROP BUS MSYN.
	1010	133		
444	1011		LAI 0	
	1011	006		
	1012	000		
445	1013		OUT REG5	‡DROP THE SWITCH REGISTER ENABLE.
	1013	133		
446	1014		OUT REG2	‡CLEAR THE UNIBUS ADDRESS REGISTER AND REMOVE
KY11LB PROGRAM	RT-11	MACRO	VM02-10	00:13:25 PAGE 8+

```

1014 125
447 1015 OUT REG1 ;FROM THE UNIBUS.
1015 123
448 1016 OUT REG0
1016 121
449 1017 CAL SRLD ;CALL ROUTINE TO REPLACE THE CONTENTS OF SWITCH REGISTER.
1017 106
1020 250
1021 010
450 1022 RET
1022 007
451
452
453 ;HALT ROUTINE.
454 ;THIS ROUTINE SERVICES THE HALT/SINGLE STEP
455 ;KEY FUNCTION AND ALSO SERVICES A PROGRAM
456 ;HALT BY THE PROCESSOR.
457 1023 HLT1: INP REG5
1023 113
458 1024 NDI 40 ;IS PROCESSOR ALREADY HALTED?
1024 044
1025 040
459 1026 JFZ SS1 ;YES. DO SINGLE STEP FUNCTION.
1026 110
1027 034
1030 010
460 1031 CAL MDTST ;NO. IS CNTRL KEY DEPRESSED?
1031 106
1032 365
1033 000
461 1034 SS1: LAI 41 ;YES.SET HALT REQUEST AND CLEAR BUS BITS.IF PROCESSOR
1034 006
1035 041
462 1036 OUT REG5 ;IS HALTED IT WILL PROCEED ONE INSTRUCTION.
1036 133
463 1037 HLT15: LAI 1 ;DROP THE CLEAR BUS BIT.
1037 006
1040 001
464 1041 OUT REG5
1041 133
465 1042 HLT2: LCI 0 ;SET UP A TIMING LOOP TO WAIT FOR HALT
1042 026
1043 000
466 1044 LBI 12 ;GRANTS IN CASE PROCESSOR IS DOING A RESET .
1044 016
1045 012
467 1046 HLT25: INP REG5
1046 113
468 1047 NDI 40 ;HALT GRANT RECEIVED?
1047 044
1050 040
469 1051 JFZ HLT3 ;YES.
1051 110
1052 067
1053 010
470 1054 DC C ;NO,DECREMENT COUNTER.
1054 021
KY111LB PROGRAM RT-11 MACRO UM02-10 00:13:25 PAGE 84

```

```

471 1055          JFZ HLT25      ‡DONE COUNT?NO.
      1055      110
      1056      046
      1057      010
472 1060          DC B          ‡DECREMENT COUNTER.
      1060      011
473 1061          JFZ HLT25      ‡TIMED OUT? NO.
      1061      110
      1062      046
      1063      010
474 1064          JMP BUSERR     ‡YES. GO TO BUS ERROR ROUTINE.
      1064      104
      1065      257
      1066      001
475 1067          HLT3: LAI 0      ‡RECEIVED GRANT,NOW CLEAR INDICATORS.
      1067      006
      1070      000
476 1071          OUT REG6
      1071      135
477 1072          LAI 307        ‡LOAD UNIBUS ADDRESS OF PC (R7) (777707)
      1072      006
      1073      307
478 1074          OUT REG0      ‡INTO THE UNIBUS ADDRESS REGISTER AND
      1074      121
479 1075          LAI 377        ‡ENABLE ONTO THE UNIBUS.
      1075      006
      1076      377
480 1077          OUT REG1
      1077      123
481 1100          LAI 7
      1100      006
      1101      007
482 1102          OUT REG2
      1102      125
483 1103          CAL DATI1     ‡CALL THE DATI SUBROUTINE.
      1103      106
      1104      230
      1105      001
484 1106          JMP MOV1      ‡DISPLAY THE PC.
      1106      104
      1107      042
      1110      001
485
486
487              ‡INIT KEY SERVICE ROUTINE.
488              ‡THIS ROUTINE SERVICES THE INIT KEY
489              ‡FUNCTION.
490 1111          INIT1: CAL MDTST ‡CHECK THAT CNTRL KEY HAS BEEN DEPRESSED AND
      1111      106
      1112      365
      1113      000
491 1114          CAL HLTST     ‡THAT THE PROCESSOR IS HALTED.
      1114      106
      1115      362
      1116      010
492 1117          CAL INITX     ‡CALL THE INITIALIZE SUBROUTINE.
      1117      106
KY11LB PROGRAM RT-11 MACRO VM02-10 00:13:25 PAGE 8+

```

```

1120 130
1121 010
493 1122 LAI 1 ;DROP THE BUS INIT BIT LEAVING THE HALT REQUEST
1122 006
1123 001
494 1124 OUT REG5 ;BIT SET.
1124 133
495 1125 JMP DISP1
1125 104
1126 023
1127 000
496
497
498 ;INITIALIZE SUBROUTINE.
499 ;THIS SUBROUTINE SETS THE BUS INIT
500 ;BIT FOR 150 MILLISECONDS. THIS IS USED
501 ;BY THE START AND INIT KEY FUNCTIONS.
502 1130 INITX: LAI 3
1130 006
1131 003
503 1132 OUT REG5 ;SET BOTH BUS INIT AND HALT REQUEST BITS.
1132 133
504 1133 TIMER: LBI 12 ;PRESET COUNTERS FOR A 150 MILLISECOND DELAY.
1133 016
1134 012
505 1135 LCI 0
1135 026
1136 000
506 1137 INITX2: DC C ;DECREMENT COUNTERS AND RETURN WHEN DONE.
1137 021
507 1140 JFZ INITX2
1140 110
1141 137
1142 010
508 1143 DC B
1143 011
509 1144 JFZ INITX2
1144 110
1145 137
1146 010
510 1147 RET
1147 007
511
512
513 ;START ROUTINE.
514 ;THIS ROUTINE SERVICES THE START KEY FUNCTION
515 ;BY LOADING THE PC (R7) WITH THE UNIBUS
516 ;ADDRESS POINTER,GENERATING BUS INIT, AND
517 ;ALLOWING THE PROCESSOR TO CONTINUE.
518 1150 STRT1: CAL MDTST ;CHECK THAT CNTRL KEY IS DEPRESSED AND
1150 106
1151 365
1152 000
519 1153 CAL HLTST ;THAT PROCESSOR IS HALTED.
1153 106
1154 362
1155 010
KY111LB PROGRAM RT-11 MACRO VM02-10 00:13:25 PAGE 8+

```

520	1156		LHI 240	‡RESET PROGRAMMED HALT FLAG (200).
	1156	056		
	1157	240		
521	1160		LAI 307	‡LOAD ADDRESS OF PC (777707) INTO THE
	1160	006		
	1161	307		
522	1162		OUT REG0	‡UNIBUS ADDRESS POINTER.
	1162	121		
523	1163		LAI 377	
	1163	006		
	1164	377		
524	1165		OUT REG1	
	1165	123		
525	1166		LAI 17	‡SET THE ENABLE BIT (4) AND THE
	1166	006		
	1167	017		
526	1170		OUT REG2	‡BUS C1 BIT (10).
	1170	125		
527	1171		LLI 13	‡SET THE MEMORY POINTER TO UNIBUS ADDRESS POINTER
	1171	066		
	1172	013		
528	1173		CAL DAT01	‡AND CALL THE DAT0 SUBROUTINE.
	1173	106		
	1174	361		
	1175	001		
529	1176		CAL INITX	‡CALL THE INITIALIZE SUBROUTINE TO GENERATE
	1176	106		
	1177	130		
	1200	010		
530	1201		LAI 2	‡BUS INITIALIZE.
	1201	006		
	1202	002		
531	1203		OUT REG5	‡DROP BUS INIT AND HALT REQUEST BITS AND SET BUS
	1203	133		
532	1204		LAI 0	‡CLEAR BIT. THEN DROP BUS CLEAR BIT.
	1204	006		
	1205	000		
533	1206		OUT REG5	
	1206	133		
534	1207		JMP SRDISP	‡JUMP TO SWITCH REGISTER DISPLAY ROUTINE.
	1207	104		
	1210	261		
	1211	010		
535				
536				
537				‡CONTINUE ROUTINE.
538				‡THIS ROUTINE SERVICES THE CONT KEY FUNCTION.
539	1212		CONT1: CAL MDTST	‡CHECK IF THE CNTRL KEY IS DEPRESSED.
	1212	106		
	1213	365		
	1214	000		
540	1215		LHI 240	‡RESET PROGRAMMED HALT FLAG.
	1215	056		
	1216	240		
541	1217		LAI 40	‡SET THE BUS CLEAR BIT TO ALLOW PROCESSOR
	1217	006		
	1220	040		

KY111LB PROGRAM RT-11 MACRO VM02-10 00:13:25 PAGE 8+

```

542 1221          OUT REG5          ;TO CONTINUE. IF THE PROCESSOR IS ALREADY
    1221          133
543 1222          LAI 0              ;RUNNING THIS WILL HAVE NO EFFECT.
    1222          006
    1223          000
544 1224          OUT REG5
    1224          133
545 1225          JMP SRDISP        ;JUMP TO SWITCH REGISTER DISPLAY ROUTINE.
    1225          104
    1226          261
    1227          010
546
547
548
549
550
551
552
553 1230          LSR1: LLI 10
    1230          066
    1231          010
554 1232          LA M              ;MOVE TWO WORDS TO REGISTERS A AND B.
    1232          307
555 1233          IN L
    1233          060
556 1234          LB M
    1234          317
557 1235          LLI 16           ;RESET MEMORY POINTER TO SWITCH REGISTER
    1235          066
    1236          016
558 1237          LM A              ;IMAGE AREA AND LOAD MEMORY FROM REGISTERS
    1237          370
559 1240          IN L              ;A AND B.
    1240          060
560 1241          LM B
    1241          371
561 1242          CAL SRLD         ;CALL THE SR LOAD SUBROUTINE AND
    1242          106
    1243          250
    1244          010
562 1245          JMP SRDISP        ;JUMP TO SWITCH REGISTER DISPLAY ROUTINE.
    1245          104
    1246          261
    1247          010
563
564
565
566
567
568
569
570
571 1250          SRLD: LLI 16
    1250          066
    1251          016
572 1252          LB M              ;AND LOAD THE LOW BYTE OF THE SWITCH REGISTER
    1252          317
KY11LB PROGRAM RT-11 MACRO VM02-10 00:13:25 PAGE 8+

```

573	1253		LA B	#WITH THE FIRST WORD.
	1253	301		
574	1254		OUT SRLB	
	1254	127		
575	1255		IN L	
	1255	060		
576	1256		LA M	#LOAD THE HIGH BYTE OF THE SWITCH REGISTER
	1256	307		
577	1257		OUT SRHB	#WITH THE NEXT WORD FROM MEMORY.
	1257	131		
578	1260		RET	
	1260	007		
579				
580				
581				#SWITCH REGISTER DISPLAY ROUTINE.
582				#THIS ROUTINE MOVES THE CONTENTS OF THE
583				#SWITCH REGISTER IMAGE AREA OF RAM TO THE
584				#DISPLAY AREA OF RAM AND SETS THE SWITCH
585				#REGISTER DISPLAYED (SR DISP) INDICATOR.
586	1261		SRRDISP: LLI 16	
	1261	066		
	1262	016		
587	1263		LCI 0	
	1263	026		
	1264	000		
588	1265		LA M	
	1265	307		
589	1266		IN L	
	1266	060		
590	1267		LB M	
	1267	317		
591	1270		LLI 0	
	1270	066		
	1271	000		
592	1272		LM A	
	1272	370		
593	1273		IN L	
	1273	060		
594	1274		LM B	
	1274	371		
595	1275		IN L	
	1275	060		
596	1276		LM C	
	1276	372		
597	1277		LAI 40	
	1277	006		
	1300	040		
598	1301		OUT REG6	
	1301	135		
599	1302		JMP DISP1	
	1302	104		
	1303	023		
	1304	000		
600				
601				
602				#LOAD ADDRESS ROUTINE.
603				#THIS ROUTINE SERVICES THE LAD KEY FUNCTION

KY11LB PROGRAM RT-11 MACRO VM02-10

00:13:25 PAGE 8+

```

604
605
606
607
608 1305      LAD1:  LAI 0
      1305      006
      1306      000
609 1307      OUT REG6
      1307      135
610 1310      LLI 10      ;MOVE TEMPORARY TO UNIBUS ADDRESS POINTER.
      1310      066
      1311      010
611 1312      LC M
      1312      327
612 1313      IN L
      1313      060
613 1314      LB M
      1314      317
614 1315      IN L
      1315      060
615 1316      LA M
      1316      307
616 1317      NDI 3
      1317      044
      1320      003
617 1321      IN L
      1321      060
618 1322      LM C
      1322      372
619 1323      IN L
      1323      060
620 1324      LM B
      1324      371
621 1325      IN L
      1325      060
622 1326      LM A
      1326      370
623 1327      CLR1: LAI 0
      1327      006
      1330      000
624 1331      OUT REG6
      1331      135
625 1332      CLR2: LLI 10      ;CLEAR THE TEMPORARY AREA.
      1332      066
      1333      010
626 1334      LM A
      1334      370
627 1335      IN L
      1335      060
628 1336      LM A
      1336      370
629 1337      IN L
      1337      060
630 1340      LM A
      1340      370
631 1341      JMP MOV1
      1341      104
KY11LB PROGRAM RT-11 MACRO VM02-10 00:13:25 PAGE B+
```

1342	042		
1343	001		
632			
633			
634			
635			‡DISPLAY ADDRESS ROUTINE.
636			‡THIS ROUTINE SERVICES THE DIS AD KEY
637			‡FUNCTION. IT MOVES THE UNIBUS ADDRESS POINTER
638	1344	DISPAD: LAI 0	‡TO THE DISPLAY AREA OF RAM.
	1344	006	
	1345	000	
639	1346	OUT REG6	‡CLEAR INDICATORS.
	1346	135	
640	1347	LLI 15	
	1347	066	
	1350	015	
641	1351	LA M	
	1351	307	
642	1352	NDI 3	‡CLEAR EXAMINE AND DEPOSIT FLAGS.
	1352	044	
	1353	003	
643	1354	LM A	
	1354	370	
644	1355	LLI 13	‡SET MEMORY POINTER TO UNIBUS ADDRESS POINTER AND
	1355	066	
	1356	013	
645	1357	JMP MOV2	‡JUMP TO MOVE ROUTINE TO MOVE THE DATA INTO DISPLAY.
	1357	104	
	1360	044	
	1361	001	
646			
647			
648			‡HALT TEST SUBROUTINE.
649			‡THIS ROUTINE TESTS TO SEE IF THE
650			‡PROCESSOR IS HALTED.
651	1362	HLTST: INP REG5	
	1362	113	
652	1363	NDI 40	‡IS HALT BUSY SET?
	1363	044	
	1364	040	
653	1365	JTZ DISP1	‡NO. GO TO DISPLAY.
	1365	150	
	1366	023	
	1367	000	
654	1370	RET	‡YES. RETURN.
	1370	007	
655	1371	NUM1: LLI 6	
	1371	066	
	1372	006	
656	1373	LA M	
	1373	307	
657	1374	NDI 10	‡CNTRL KEY DEPRESSED?
	1374	044	
	1375	010	
658	1376	JTZ NUM1X	‡NO. GO TO DIGIT 1 ROUTINE.
	1376	150	
	1377	004	

	1400	001		
659	1401	056	MAINT1: LHI 40	#YES. MAINTENANACE MODE!!!
	1401	040		
	1402	040		
660	1403	006	LAI 100	#DO NOT LOOK FOR PROGRAMMED HALTS AND
	1403	100		
	1404	100		
661	1405	135	OUT REG6	#SET THE MAINTENANCE MODE INDICATOR.
	1405	066		
662	1406	000	LLI 0	#READ IN 12 BITS OF MPC AND DISPLAY.
	1406	000		
	1407	000		
663	1410	115	INP REG6	
	1410	370		
664	1411	060	LM A	
	1411	060		
665	1412	117	IN L	
	1412	060		
666	1413	044	INP REG7	
	1413	017		
667	1414	017	NDI 17	
	1414	044		
	1415	017		
668	1416	370	LM A	
	1416	060		
669	1417	060	IN L	
	1417	060		
670	1420	076	LMI 0	
	1420	000		
	1421	000		
671	1422	106	MAINT2: CAL DISP15	#CALL THE DISPLAY SUBROUTINE.
	1422	031		
	1423	000		
	1424	000		
672	1425	016	LBI 0	#THE FOLLOWING IS THE KEYSERVICE ROUTINE
	1425	000		
	1426	000		
673	1427	046	LEI 200	#FOR THOSE KEY FUNCTIONS AVAILABLE IN
	1427	200		
	1430	200		
674	1431	066	LLI 3	#MAINTENANCE MODE.
	1431	003		
	1432	003		
675	1433	307	LA M	
	1433	032		
676	1434	032	RAR	
	1434	032		
677	1435	140	JTC MDISAD	
	1435	107		
	1436	011		
	1437	011		
678	1440	032	RAR	
	1440	032		
679	1441	032	RAR	
	1441	032		
680	1442	032	RAR	
	1442	032		

KY11LB PROGRAM RT-11 MACRO VM02-10 00:13:25 PAGE 84

681	1443		JTC MCLR
	1443	140	
	1444	154	
	1445	011	
682	1446		IN L
	1446	060	
683	1447		IN L
	1447	060	
684	1450		LA M
	1450	307	
685	1451		RAR
	1451	032	
686	1452		JTC MDSIAT
	1452	140	
	1453	126	
	1454	011	
687	1455		RAR
	1455	032	
688	1456		JTC TAKBUS
	1456	140	
	1457	201	
	1460	011	
689	1461		IN L
	1461	060	
690	1462		IN L
	1462	060	
691	1463		LA M
	1463	307	
692	1464		RAR
	1464	032	
693	1465		JTC MHLT
	1465	140	
	1466	162	
	1467	011	
694	1470		RAR
	1470	032	
695	1471		JTC MCONT1
	1471	140	
	1472	143	
	1473	011	
696	1474		RAR
	1474	032	
697	1475		JTC MBOOT
	1475	140	
	1476	207	
	1477	011	
698	1500		RAR
	1500	032	
699	1501		JTC MSTR11
	1501	140	
	1502	173	
	1503	011	
700	1504		JMP MAINT2
	1504	104	
	1505	022	
	1506	011	

701 1507
 KY11LB PROGRAM RT-11 MACRO VM02-10

MDISAD: LLI 0

*READ IN UNIBUS ADDRESS LINES AND DISPLAY.
 00:13:25 PAGE 8*

1507	066		
1510	000		
702 1511		INP REG2	
1511	105		
703 1512		LM A	
1512	370		
704 1513		IN L	
1513	060		
705 1514		INP REG3	
1514	107		
706 1515		LM A	
1515	370		
707 1516		IN L	
1516	060		
708 1517		INP REG4	
1517	111		
709 1520		NDI 3	
1520	044		
1521	003		
710 1522		LM A	
1522	370		
711 1523		JMP MAINT2	
1523	104		
1524	022		
1525	011		
712 1526		MDSDAT: LLI 0	*READ IN UNIBUS DATA LINES AND DISPLAY.
1526	066		
1527	000		
713 1530		INP DBLB	
1530	101		
714 1531		LM A	
1531	370		
715 1532		IN L	
1532	060		
716 1533		INP DBHB	
1533	103		
717 1534		LM A	
1534	370		
718 1535		IN L	
1535	060		
719 1536		LMI 0	
1536	076		
1537	000		
720 1540		JMP MAINT2	
1540	104		
1541	022		
1542	011		
721 1543		MCONT1: LAI 300	*ASSERT MANUAL CLOCK ENABLE AND MANUAL
1543	006		
1544	300		
722 1545		OUT REG5	*CLOCK BITS.
1545	133		
723 1546		LAI 100	*CLEAR MANUAL CLOCK BIT.
1546	006		
1547	100		
724 1550		OUT REG5	
1550	133		

KY111LB PROGRAM RT-11 MACRO VM02-10 00:13:25 PAGE 8+

```

725 1551          JMP MAINT1
      1551      104
      1552      001
      1553      011
726 1554      MCLR: LAI 0          #CLEAR THE MAINTENANCE MODE INDICATOR AND
      1554      006
      1555      000
727 1556          OUT REG6          #JUMP OUT OF MAINTENANCE MODE VIA THE HALT ROUTINE.
      1556      135
728 1557          JMP HLT15
      1557      104
      1560      037
      1561      010
729 1562      MHLT: LAI 140        #ASSERT MANUAL CLOCK ENABLE AND CLEAR BUS BITS.
      1562      006
      1563      140
730 1564          OUT REG5
      1564      133
731 1565          LAI 100          #DROP CLEAR BUS BIT.
      1565      006
      1566      100
732 1567          OUT REG5
      1567      133
733 1570          JMP MAINT1
      1570      104
      1571      001
      1572      011
734 1573      MSTRT1: LAI 0        #DROP MANUAL CLOCK ENABLE.
      1573      006
      1574      000
735 1575          OUT REG5
      1575      133
736 1576          JMP MAINT1
      1576      104
      1577      001
      1600      011
737 1601      TAKBUS: LAI 20       #SET TAKE BUS BIT AND
      1601      006
      1602      020
738 1603          OUT REG5          #JUMP OUT OF MAINTENANCE MODE.
      1603      133
739 1604          JMP MCLR
      1604      104
      1605      154
      1606      011
740 1607      MBOOT: LAI 200       #SET AND CLEAR THE BOOT BIT.
      1607      006
      1610      200
741 1611          OUT REG6
      1611      135
742 1612          LAI 0
      1612      006
      1613      000
743 1614          OUT REG6
      1614      135
744 1615          JMP MAINT1
      1615      104
KY11LB PROGRAM RT-11 MACRO VM02-10 00:13:25 PAGE 8+

```

1616	001			
1617	011			
745 1620		NUM7:	LLI 6	
1620	066			
1621	006			
746 1622			LA M	
1622	307			
747 1623			NDI 10	‡CNTRL KEY DEPRESSED?
1623	044			
1624	010			
748 1625			JTZ NUM7X	‡NO. GO TO DIGIT 7 ROUTINE.
1625	150			
1626	376			
1627	000			
749 1630			LCI 2	‡OFFSET ADDRESS CALCULATED BY ADDING THE
1630	026			
1631	002			
750 1632			LLI 14	‡UNIBUS ADDRESS POINTER TO TEMPORARY PLUS
1632	066			
1633	014			
751 1634		ADD:	LB M	‡TWO.
1634	317			
752 1635			DC L	
1635	061			
753 1636			LA M	
1636	307			
754 1637			LLI 10	
1637	066			
1640	010			
755 1641			AD C	
1641	202			
756 1642			AD M	
1642	207			
757 1643			LM A	
1643	370			
758 1644			IN L	
1644	060			
759 1645			LA B	
1645	301			
760 1646			AC M	
1646	217			
761 1647			LM A	
1647	370			
762 1650			JMP MOV1	‡DISPLAY ANSWER IN TEMPORARY.
1650	104			
1651	042			
1652	001			
763 1653		NUM6:	LLI 6	
1653	066			
1654	006			
764 1655			LA M	
1655	307			
765 1656			NDI 10	‡CNTRL KEY DEPRESSED?
1656	044			
1657	010			
766 1660			JTZ NUM6X	‡NO. GO TO DIGIT 6 ROUTINE.
1660	150			

KY11LB PROGRAM RT-11 MACRO VM02-10 00:13:25 PAGE 8+

```

1661 377
1662 000
767 1663 LCI 0 ;YES. SET UP MEMORY POINTER TO ADD
1663 026
1664 000
768 1665 LLI 17 ;THE SWITCH REGISTER IMAGE TO TEMPORARY
1665 066
1666 017
769 1667 JMP ADD ;PLUS ZERO.
1667 104
1670 234
1671 011
770 ;THATS IT FOLKS!!!!
771 000001 .END
KY11LB PROGRAM RT-11 MACRO VM02-10 00:13:25 PAGE 8+
SYMBOL TABLE

```

A	=	000000	ADD	001634	B	=	000001	
BADLD	000744	BEGIN	000001	BEG1	000016			
BOOT1	000463	BUSERR	000657	C	=	000002		
CLR1	001327	CLR2	001332	CONT1	001212			
D	=	000003	DAT11	000630	DAT12	000643		
DAT01	000761	DBHB	=	000001	DBLB	=	000000	
DEF1	000671	DEF2	000715	DISPAD	001344			
DISP1	000023	DISP15	000031	DISP2	000062			
DISP3	000132	DISP4	000136	DISP45	000137			
DISP5	000163	E	=	000004	EXAM1	000507		
EXAM2	000530	GPRT1	000574	GPRT2	000624			
GPRT3	000627	H	=	000005	HLTST	001362		
HLT1	001023	HLT15	001037	HLT2	001042			
HLT25	001046	HLT3	001067	INCAD	000551			
INITX	001130	INITX2	001137	INIT1	001111			
KEYS	=	000005	KEYSEV	000175	L	=	000006	
LAD1	001305	LSR1	001230	M	=	000007		
MAINT1	001401	MAINT2	001422	MBOOT	001607			
MCLR	001554	MCONT1	001543	MDISAD	001507			
MSDAT	001526	MDTST	000365	MEM2	001001			
MHLT	001562	MOV1	000442	MOV2	000444			
MSTRT1	001573	NUMX	000407	NUM0	=	000405		
NUM0X	000405	NUM1	001371	NUM1X	000404			
NUM2	=	000403	NUM2X	000403	NUM3	=	000402	
NUM3X	000402	NUM4	=	000401	NUM4X	000401		
NUM5	=	000400	NUM5X	000400	NUM6	001653		
NUM6X	000377	NUM7	001620	NUM7X	000376			
NXT	000052	OVER	000013	REG0	=	000000		
REG1	=	000001	REG2	=	000002	REG3	=	000003
REG4	=	000004	REG5	=	000005	REG6	=	000006
REG7	=	000007	SHFT1	000335	SHFT2	000343		
SRDISP	001261	SRHB	=	000004	SRLB	=	000003	
SRLD	001250	SS1	001034	START	000000			
STRT1	001150	TAKBUS	001601	TIMER	001133			

```

. ABS. 001672 000
000000 001
ERRORS DETECTED: 0
FREE CORE: 15380. WORDS

```

```
TEXT,TEXT=MBOO8E,TEXT
```

```
*
```

**APPENDIX B
IC DESCRIPTIONS**

7493 BINARY COUNTER

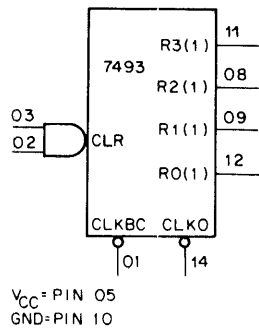
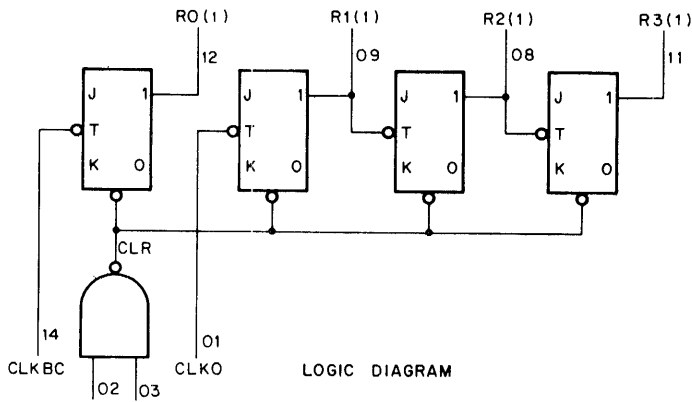

7493 TRUTH TABLE
(SEE NOTES)

CLKBC INPUT	PULSE	OUTPUT			
		R0 (1)	R1 (1)	R2 (1)	R3 (1)
0	0	0	0	0	0
1	1	0	0	0	0
2	0	1	0	0	0
3	1	1	0	0	0
4	0	0	1	0	0
5	1	0	1	0	0
6	0	1	1	0	0
7	1	1	1	0	0
8	0	0	0	1	0
9	1	0	0	1	0
10	0	1	0	1	0
11	1	1	0	1	0
12	0	0	1	1	0
13	1	0	1	1	0
14	0	1	1	1	0
15	1	1	1	1	0

0 = LOW 1 = HIGH

Notes:

1. Truth table applies when 7493 is used as 4-bit ripple – through counter.
2. Output RO(1) connected to input CLK0.
3. To reset all outputs to logical 0 both pins 02 and 03 inputs must be high.
4. Either (or both) reset inputs R0(1) (pins 02 and 03) must be low to count.

8641 QUAD BUS TRANSCEIVER

The 8641 consists of four identical receiver/drivers and a single enabling gate in one package for interfacing with the PDP-11 Unibus. The transceiver drivers are enabled when ENABLE A and ENABLE B are both low. The other input of each driver is connected to the data to be sent to the Unibus. For example, when enabled, DATA IN 1 (pin 2) is read to the Unibus via BUS 1 (pin 1). During a write operation, data comes from the Unibus as BUS 1 (pin 1) and is passed through the receiver to the device as DATA OUT 1 (pin 3).

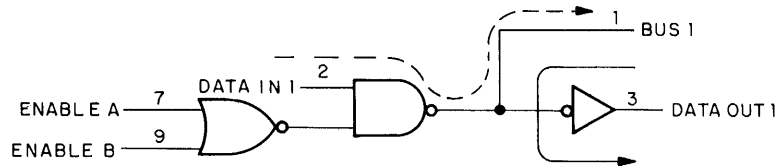
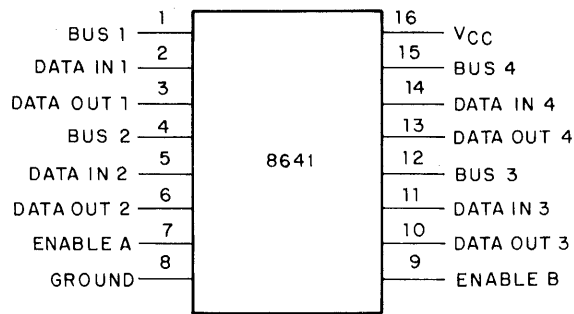

IC - 8641

74154 4-LINE TO 16-LINE DECODER

The 74154 4-Line to 16-Line Decoder decodes four binary-coded inputs into one of 16 mutually-exclusive outputs when both strobe inputs (G1 and G2) are low. The decoding function is performed by using the four input lines to address the output line, passing data from one of the strobe inputs with the other strobe input low. When either strobe input is high, all outputs are high.

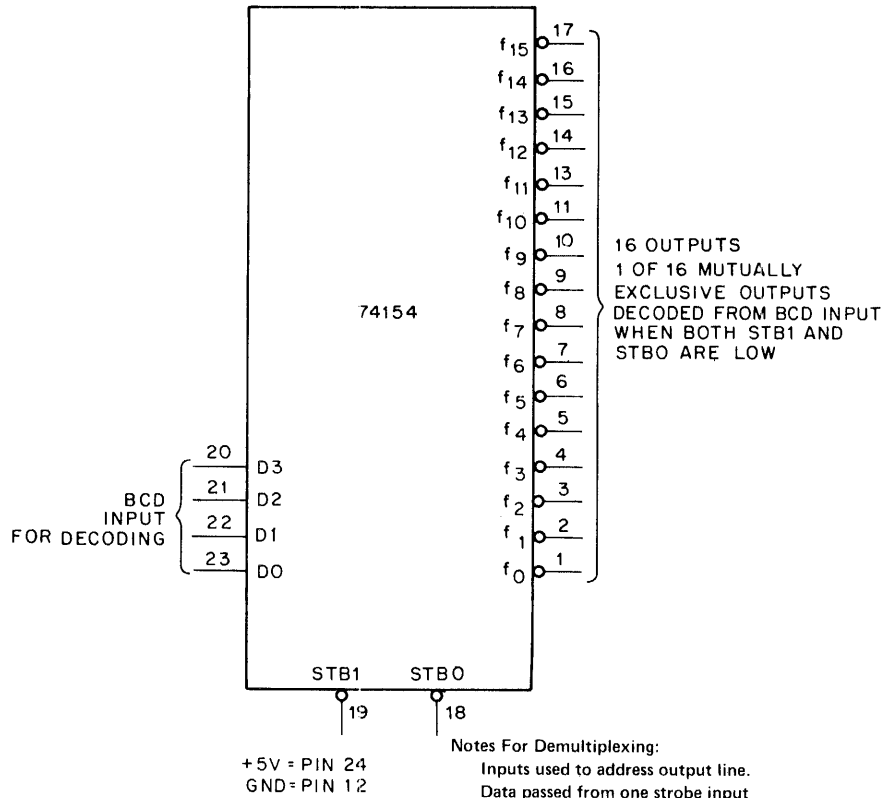

Notes For Demultiplexing:
Inputs used to address output line.
Data passed from one strobe input with other strobe held low. Either strobe high gives all high outputs.

1C - 74154

74175 QUAD STORAGE REGISTER

TRUTH TABLE

INPUT t_n	OUTPUTS t_{n+1}	
D	R(1)R(0)	
H	H	L
L	L	H

t_n = Bit time before clock pulse.

t_{n+1} = Bit time after clock pulse.

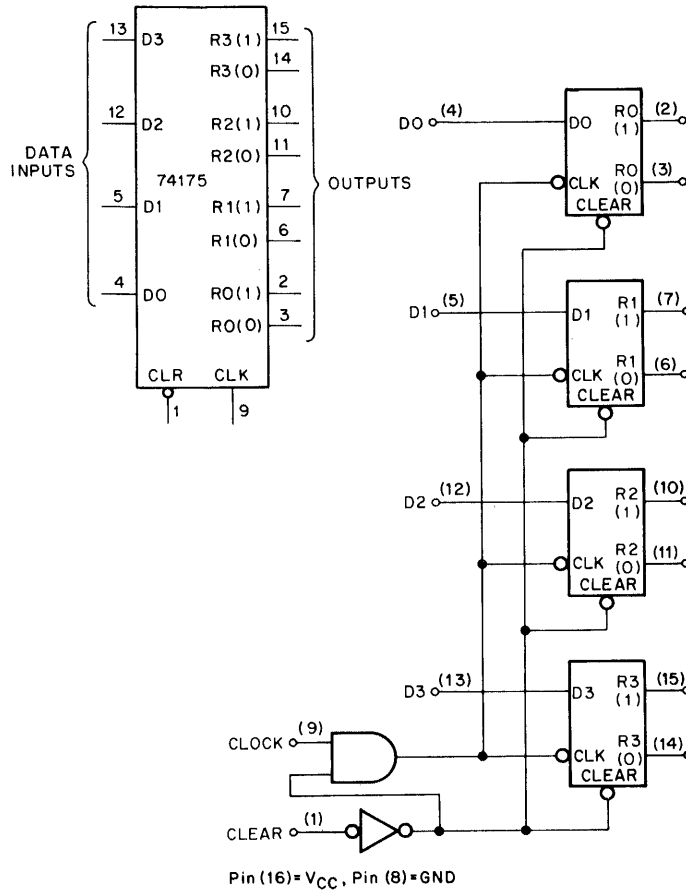

IC - 74175

Reader's Comments

KY11-LB Programmer's Console/Interface
Module Operation and Maintenance Manual
EK-KY1LB-MM-001

Your comments and suggestions will help us in our continuous effort to improve the quality and usefulness of our publications.

What is your general reaction to this manual? In your judgment is it complete, accurate, well organized, well written, etc.? Is it easy to use? _____

What features are most useful? _____

What faults do you find with the manual? _____

Does this manual satisfy the need you think it was intended to satisfy? _____

Does it satisfy *your* needs? _____ Why? _____

Would you please indicate any factual errors you have found. _____

Please describe your position. _____

Name _____ Organization _____

Street _____ Department _____

City _____ State _____ Zip or Country _____

Fold Here

Do Not Tear - Fold Here and Staple

FIRST CLASS
PERMIT NO. 33
MAYNARD, MASS.

BUSINESS REPLY MAIL
NO POSTAGE STAMP NECESSARY IF MAILED IN THE UNITED STATES

Postage will be paid by:

Digital Equipment Corporation
Technical Documentation Department
Maynard, Massachusetts 01754

