

DEC WANserver 150 Installation/Owner's Guide

Order No. EK-A0497-IN.001

Update Information:

This is a new manual.

First Printing: May 1991

The information in this document is subject to change without notice and should not be construed as a commitment by Digital Equipment Corporation. Digital Equipment Corporation assumes no responsibility for any errors that may appear in this document.

The software described in this document is furnished under a license and may be used or copied only in accordance with the terms of such license.

No responsibility is assumed for the use or reliability of software on equipment that is not supplied by Digital Equipment Corporation or its affiliated companies.

Restricted Rights: Use, duplication, or disclosure by the U.S. Government is subject to restrictions as set forth in subparagraph (c)(1)(ii) of the Rights in Technical Data and Computer Software clause at DFARS 252.227-7013.

Copyright ©1991 by Digital Equipment Corporation
All Rights Reserved
Printed in UK

The READER'S COMMENTS form on the last page of this document requests the user's critical evaluation to assist in preparing future documentation.

The following are trademarks of Digital Equipment Corporation:

DDCMP	Packetnet	UNIBUS
DEC	PDP	VAX
DECnet	Q-bus	VAXcluster
DECrouter	Q22-bus	VMS
DECUS	RSTS	VT
DECwriter	RSX	
MASSBUS	ULTRIX	
MicroVAX	ULTRIX-32	

(Notice: Class A Computing Device)

This equipment generates, uses, and may emit radio frequency energy. The equipment has been type tested and found to comply with the limits for a Class A Computing Device pursuant to Subpart J of Part 15 of FCC Rules, which are designed to provide reasonable protection against such radio frequency interference when operated in a commercial environment. Operation of this equipment in a residential area may cause interference; in which case, measures taken to correct the interference are at the user's expense.

This manual was produced by the Corporate Backbone Networks group in Reading, UK.

Contents

How to Use This Manual

Part I: Basic Installation

1 Preinstallation Tasks

1.1	Introduction	1-1
1.1.1	System Installation	1-1
1.1.2	Hardware Overview	1-2
1.2	Preinstallation Checks	1-4
1.3	Unpack the DEC WANserver 150 Hardware	1-6
1.4	Complete the Server ID Card	1-7

2 Installing the DEC WANserver 150

2.1	Overview	2-6
2.2	Put the Server in Place	2-6
2.3	Check the Voltage Switch Setting	2-6
2.4	Connect to a Power Source	2-9
2.5	Basic Installation Troubleshooting	2-13

3 Connecting to Networks

3.1	Connect Serial Ports	3-2
3.1.1	Connecting to the 25-Pin Device Port	3-3
3.1.2	Connecting to the 50-Pin Device Port	3-5
3.2	Connect Ethernet	3-7
3.2.1	Standard Ethernet Connection	3-8
3.2.2	ThinWire Ethernet Connection	3-10

4 Configuring the DEC WANserver 150

4.1	Attaching a Console	4-1
4.2	Configuring the Server	4-5

Part II: Advanced Installation

5 Rack Mounting

6 Making Connections to Networks and Fitting Adapters

6.1	Connecting to the Local Area Network	6-1
6.1.1	Connecting to a Standard Ethernet	6-2
6.1.2	Connecting to ThinWire Ethernet	6-4
6.2	Adapters	6-8
6.2.1	Fitting to the 25-Pin Port	6-9
6.2.2	Fitting Between the 50-Pin Cables	6-10

7 Dealing with Problems

7.1	Software Requirements	7-1
7.2	Reinitialize the DEC WANserver 150	7-2
7.3	Running Diagnostics	7-2
7.3.1	Interpreting the Diagnostic Dot	7-5

7.3.2	Down-Line Loading Problems	7-7
7.4	Loopback Tests	7-9

Part III: Appendixes

A Standards Supported, and Physical, Environmental, Electrical and Cabling Specifications

A.1	Functions and Standards	A-1
A.2	Physical Considerations	A-2
A.3	Environmental Considerations	A-3
A.4	Electrical Considerations	A-4
A.5	Cabling Requirements	A-5
A.6	Notes on Cable Configuration	A-6

B Server Controls and Indicators, and Connector and Cable Pin Descriptions

B.1	Server Controls and Indicators	B-1
B.2	Connectors	B-3
B.2.1	Ethernet Transceiver Interface	B-3
B.2.2	Device Port Connectors	B-4
B.2.2.1	25-Pin D-Connectors	B-4
B.2.2.2	50-Pin D-Connectors	B-6
B.2.3	Console Port Connector	B-10
B.2.4	H3103 MMJ Loopback Connector	B-11
B.2.5	H4080 Turnaround Connector	B-12
B.2.6	Other Loopback Connectors	B-13
B.3	Cable Structure	B-14
B.3.1	Device Cables and Loopback Connectors for Serial Communication 25-Pin D-Connectors	B-14
B.3.1.1	BC17D Shielded Null-Modem Cable	B-15
B.3.1.2	BC22D Shielded Null-Modem Cable	B-16
B.3.1.3	BC22F Shielded Straight-Through Modem Cable	B-17
B.3.1.4	H3266 Loopback Connector	B-18
B.3.1.5	V.24/RS-232-C Adapter (12-27591-01)	B-19

B.3.2	Device Cables and Loopback Connectors for Serial Communication 50-Pin D-Connectors	B-20
B.3.2.1	BC19B-02 Synchronous Line Adapter Cable	B-20
B.3.2.2	BC19E-02 Synchronous Line Adapter Cable	B-22
B.3.2.3	BC19F-02 Synchronous Line Adapter Cable	B-24
B.3.2.4	BC23V-02 Synchronous Line Adapter Cable	B-26
B.3.2.5	BC22X-02 BT Kilostream Adapter Cable (U.K. Only)	B-28
B.3.2.6	H3199 Universal Loopback Connector	B-30
B.3.2.7	H3198 Loopback Connector	B-32
B.3.2.8	H3250 Loopback Connector	B-34
B.3.3	Synchronous Line Extension Cables for Serial Communication	B-35
B.3.4	BC16E-xx 6-Conductor DEC Office Cable	B-35

C The Bootline Configuration Program

C.1	BCP Commands	C-1
C.1.1	CONFIGURE	C-1
C.1.2	SHOW	C-2
C.1.3	TEST	C-2
C.1.4	CONTINUE	C-2
C.2	BCP Messages	C-3
C.2.1	CONFIGURE Command Messages	C-3
C.2.2	TEST Command Messages	C-3
C.2.3	General	C-3

D Ordering Information

D.1	How to Order Hardware	D-1
D.1.1	Devices and Accessories	D-1
D.1.2	Cables and Adapters	D-3
D.2	How to Order Software	D-5
D.3	Other Services	D-5
D.3.1	Software Product Service Agreements	D-5
D.3.2	Training	D-6
D.3.3	Digital On-Site Service	D-6
D.3.4	DECmailer	D-6
D.3.5	Installation Service	D-6

Index

Figures

1-1	DEC WANserver 150 (DSRVJ)	1-3
1-2	Contents of DEC WANserver 150 Hardware Shipment	1-6
2-1	DEC WANserver 150 Back Panel	2-13
6-1	Standard Ethernet Configuration	6-3
6-2	ThinWire Ethernet Standalone Segment	6-5
6-3	DEMPR ThinWire Connection	6-6
6-4	Connections on the DempR	6-7
7-1	The Seven-Segment Display	7-3
B-1	Pin Numbers for Standard Ethernet Transceiver	B-3
B-2	Pin Numbers for 25-Pin D-Connector	B-5
B-3	Pin Numbers for 50-Pin D-Connector	B-6
B-4	Pin Numbers for the Console Port Connector	B-10
B-5	H3103 Loopback Connector—Wiring Diagram	B-11
B-6	H4080 Turnaround Connector	B-12
B-7	Wiring Diagram for BC17D Null-Modem Cable	B-15
B-8	Wiring Diagram for BC22D Null-Modem Cable	B-16
B-9	Wiring Diagram for BC22F Straight-Through Cable	B-17
B-10	H3266 Loopback Connector	B-18
B-11	Wiring Diagram for V.24/RS-232-C Adapter	B-19
B-12	Wiring Diagram for BC19B-02 Synchronous Line Adapter Cable	B-21
B-13	Wiring Diagram for BC19E-02 Synchronous Line Adapter Cable	B-23
B-14	Wiring Diagram for BC19F-02 Synchronous Line Adapter Cable	B-25
B-15	Wiring Diagram for BC23V-02 Synchronous Line Adapter Cable	B-27
B-16	Wiring Diagram for BC22X-02 BT Kilostream Adapter Cable	B-29
B-17	Wiring Diagram for H3199 Universal Loopback Connector	B-31
B-18	H3198 Loopback Connector	B-33
B-19	Wiring Diagram for 34-Pin Loopback Connector	B-34
B-20	Wiring Diagram for BC16E-xx Cable	B-35

Tables

7-1	Interpreting the Diagnostic Display	7-4
A-1	Physical Specifications of the DEC WANserver 150	A-2
A-2	Environmental Requirements of the DEC WANserver 150	A-3
A-3	Electrical Requirements	A-4
A-4	Leakage Current	A-4
A-5	Maximum Cable Lengths	A-5
A-6	Maximum Communications Distances	A-5
B-1	Server Controls	B-1
B-2	Server Indicators	B-2
B-3	Server Connectors	B-2
B-4	Pin Descriptions for Standard Ethernet Transceiver Interface	B-4
B-5	Pin Descriptions for 25-Pin D-Connector	B-5
B-6	Pin Descriptions for 50-Pin D-Connector	B-7
B-7	Pin Descriptions for Serial Communication Interface	B-10
B-8	Synchronous Line Extension Cables	B-35
C-1	Line and Node Parameters	C-1
C-2	Loopback Parameters	C-2
D-1	Country Codes	D-2
D-2	Accessories	D-2
D-3	Device Cables and Adapters	D-3

How to Use This Manual

The first two parts of this book are aimed at different sorts of reader. Read Part I if you are an ordinary user, with experience of installing hardware equipment such as PCs and printers. If you follow the instructions in Part I, and if the line speeds and protocols in the network or networks you connect to are the ones already set in your DEC WANserver 150, you will have a system that works in a simple office environment.

(Note that occasionally the text in Part I refers to Part II. This is *for information only*, as users of Part II must work through Part I initially.)

In addition to Part I, read Part II if you have experience of handling communications equipment and need instructions for:

- Rack mounting
- Cabling and fitting adapters
- Solving problems

Part III contains reference information.

Note that this book does not give details of connection to individual devices. For more information, see Part II and the *DECconnect System Planning and Configuration Guide*.

Part I

Basic Installation

Part I gives instructions for getting your DEC WANserver 150 working in an office. If you have little or no experience of installing communications equipment, you can use Part I on its own.

There are four chapters in Part I:

- Chapter 1 describes preinstallation tasks.
- Chapter 2 explains how to instal the DEC WANserver 150 and lists the basic procedures for solving problems with the installation.
- Chapter 3 describes how to make connections to networks.
- Chapter 4 explains how to configure the DEC WANserver 150.

Preinstallation Tasks

This chapter provides an overview of the system installation and of the DEC WANserver 150, and explains the things you must do before you set about installing the DEC WANserver 150.

1.1 Introduction

1.1.1 System Installation

To install the DEC WANserver 150 and get it running, you must do the following:

1. Check you are ready to install the DEC WANserver 150 (see Section 1.2).
2. Unpack the DEC WANserver 150 (see Section 1.3).
3. Complete the server ID card (see Section 1.4).
4. Put the server in place (see Chapter 2).
5. Check/adjust the voltage switch setting (see Chapter 2).
6. Connect to the power source (see Chapter 2).
7. Check that the server runs (see Chapter 2).
8. Connect the server to a network or networks (see Chapter 3.)

There is no strict order you must follow for installing the hardware and the software. You may both install and test the hardware without using the software. You can install software on a load host before you install the hardware. However, the hardware and software must both be installed to verify the system installation.

The procedures for installing the software and for verifying the system installation are contained in the installation documentation for the software.

1.1.2 Hardware Overview

The DEC WANserver 150 is a high-performance, low-cost server that connects synchronous and/or asynchronous devices (PCs, workstations, modems, for example) to each other and to an Ethernet or IEEE 802.3 local area network.

What the Server Looks Like

Figure 1-1 shows front and back views of the DEC WANserver 150.

There is only one model of the DEC WANserver 150 (DSRVJ) but this model is available with two different voltages preset. Refer to Appendix A for details.

Positions for the Server

You can install the DEC WANserver 150 in a variety of environments, including offices and computer rooms. You can place the server on a sturdy horizontal surface, such as a desk or table, or in a standard rack cabinet. Digital Equipment Corporation can also provide you with a wall/partition mounting bracket to mount the server onto an office wall directly or to suspend the server from partitioned office walls. See Appendix D for ordering information.

Figure 1-1 DEC WANserver 150 (DSRVJ)

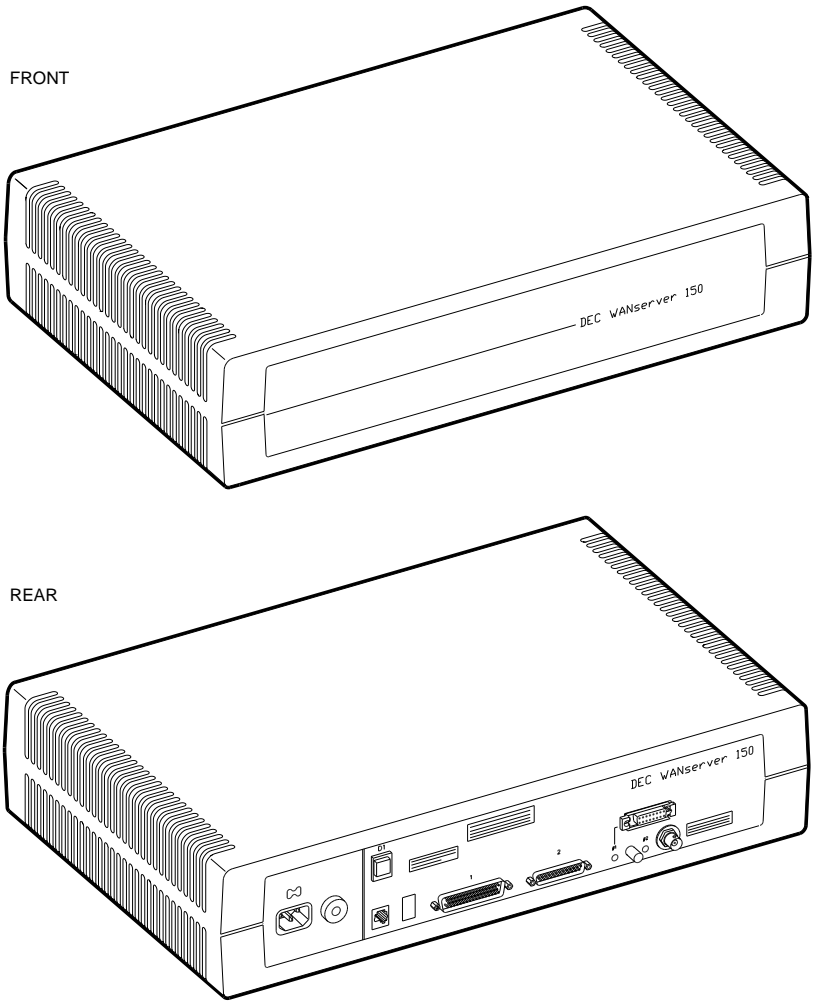

RE_EN06170C_91

1.2 Preinstallation Checks

Before installing the DEC WANserver 150, make sure of the following:

- You have identified a suitable position for the DEC WANserver 150.

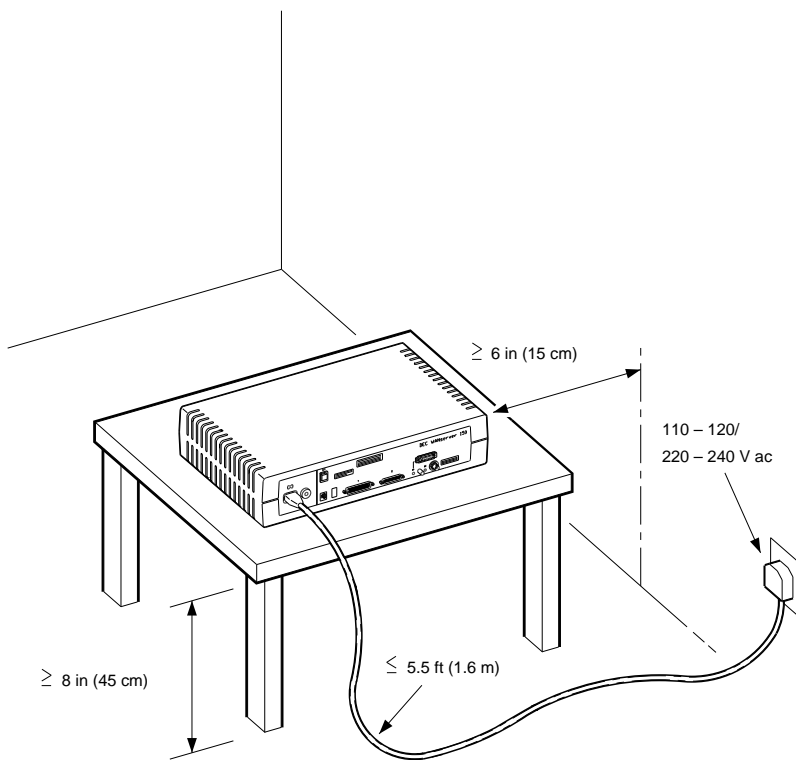

RE_EN06317C_91

- Arrangements have been made to connect the server Ethernet port to the Local Area Network (LAN), if appropriate.
- The required cabling is in place, tested, and tagged. Appendix B gives details of cables and connectors.
- The devices (modems, personal computers, hosts) are ready to be connected.

If you need to do any of the following, you must also have an asynchronous terminal (either DEC423 or EIA-232-D compatible):

- Configuring your DEC WANserver 150¹
- Hardware testing
- System verification

¹ Your software may do this. See the software manual.

1.3 Unpack the DEC WANserver 150 Hardware

Check the shipment for the items shown in Figure 1-2.

Figure 1-2 Contents of DEC WANserver 150 Hardware Shipment

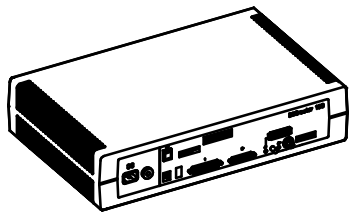

- Country-specific power cord

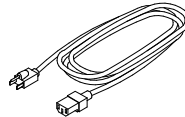

- H3199 (50-pin) Loopback Connector



- DEC WANserver 150 Installation/Owner's Guide*

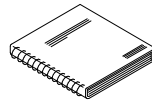

- H3266 (25-pin) Loopback Connector



- DEC WANserver 150 Identification Card*

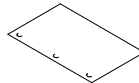

- BNC T-piece and terminators

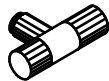

- FTZ card (Austria/Germany only)

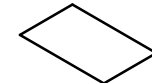

- Country-specific cable kit (V.35 or V.11/EIA-422/V.36)

- Rack-mount kit

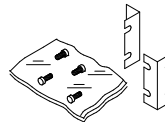

While unpacking the DEC WANserver 150, note the following:

- In case of damage:
 - Stop unpacking.
 - Contact your Digital Equipment Corporation sales representative.
- If parts are missing:
 - Identify the missing parts.
 - Contact your Digital Equipment Corporation sales representative.

In both cases, save the box and packing material in case you need to return the unit.

1.4 Complete the Server ID Card

Locate the DEC WANserver 150 Identification Card included in the server box and copy the following information in the spaces provided.

- The server's serial number. The serial number is located on the back of the server.
- The server's Ethernet address. The Ethernet address is located on the back of the server.
- The location of the server, such as an office location, building number, or floor.
- Your name and the date of installation.

Give the ID Card to the system manager.

Installing the DEC WANserver 150

WARNING

Ethernet installations may extend to thousands of meters and couple hundreds of separate items of equipment. To prevent hazardous voltages appearing on the installation, it is important that all the equipment be part of a common equipotential system as defined in IEC publications 364-4-41, clauses 413.1.2 and 413.1.6. Where it is necessary to couple equipment outside the main equipotential bonded area via Ethernet, then optical repeaters or other such galvanically isolated measures must be employed. If in doubt, please refer to Digital Equipment Corporation for advice.

ADVARSEL

Ethernet-installationer kan strække sig over tusindvis af meter og forbinde hundredevis af separate dele af udstyr. For at undgå farlig spænding i installationerne er det vigtigt, at alt udstyret er del af et fælles jordingspunkt som defineret i IEC publikation 364-4-41, klausulerne 413.1.2 og 413.1.6. Hvor det er nødvendigt at forbinde udstyr udenfor det større fælles jordingspunkt via Ethernet, skal der anvendes optisk kobling eller anden form for galvanisk isolering af udstyret. For yderligere oplysninger henvises til den lokale Digital afdeling.

VAROITUS

Ethernet-verkot voivat olla tuhansia metrejä pitkiä ja niihin voidaan liittää satoja erilaisia laitteita. Jotta verkkoon ei pääsisi syntymään vaarallisia jännitteitä, kaikkien laitteiden on ehdottomasti kuuluttava samaan potentiaalintasausjärjestelmään, jonka ominaisuudet on määritetty IEC:n julkaisussa 364-4-41, kohdissa 413.1.2 ja 413.1.6. Mikäli Ethernetiin halutaan liittää laite, joka ei kuulu potentiaalintasausjärjestelmään, on käytettävä optisia toistimia tai vastaavia galvanisesti eristettyjä menetelmiä. Jos et ole varma käytettävästä menetelmästä, ota yhteys Digitaliin.

DANGER

Une installation Ethernet peut s'étendre sur des kilomètres et relier des centaines d'éléments. Afin d'éviter tout problème électrique, vérifiez la présence d'une mise à la terre commune ainsi qu'elle est définie par l'IEC (364.4.41, clauses 413.1.2 et 413.1.6). S'il s'avère nécessaire de relier par Ethernet des équipements non rattachés à une même terre, utilisez des répéteurs optiques ou autres matériels offrant la même qualité d'isolation. En cas de doute, prenez contact avec les Services techniques Digital.

VORSICHT

Ethernet-Netzwerke können sich über mehrere tausend Meter erstrecken und mehrere hundert einzelne Geräte miteinander verbinden. Zur Vermeidung von gefährlichen Spannungen im Netzwerk ist es unbedingt erforderlich, daß alle Geräte Teil einer gemeinsamen Erdungsschleife sind, wie in den IEC-Richtlinien 364-4-41, Abschnitte 413.1.2 und 413.1.6 angegeben. Wenn Geräte außerhalb der Erdungsschleife über Ethernet miteinander verbunden werden müssen, müssen optische Repeater oder andere galvanisch getrennte Mittel verwendet werden. Falls Sie Fragen haben, wenden Sie sich an Digital Equipment.

WAARSCHUWING

Ethernet-configuraties kunnen een afstand van verschillende kilometers overbruggen en honderden afzonderlijke apparaten met elkaar verbinden. Om te vermijden dat er zich gevaarlijke spanningen zouden voordoen op de configuratie, is het belangrijk dat alle apparatuur gebruik maakt van dezelfde voeding en dezelfde aarde, zoals gedefinieerd in de IEC-publicatie 364-4-41, bepalingen 413.1.2. en 413.1.6. Wanneer apparatuur die niet op eenzelfde equipotentiaal spanningsnet is aangesloten via Ethernet gekoppeld moet worden, moet men gebruik maken van optische repeaters of van andere galvanisch isolerende technieken. Bij twijfel gelieve u contact op te nemen met Digital.

ADVARSEL

Ethernettinstallasjoner kan strekke seg over flere tusen meter og ha tilkoblet flere hundre forskjellige utstyrsenheter. For å forhindre at det skal oppstå farlige spenninger på installasjonen, er det viktig at alt utstyret tilhører et felles ekvipotensialt forbindelsessystem, slik det er definert i IEC-publikasjon 364-4-41, paragrafene 413.1.2 og 413.1.6. Der hvor det er påkrevet å koble utstyr via Ethernet utenfor det ekvipotensiale hovedområdet, er det påbudt å benytte optiske linjeforsterkere (repeatere) eller tilsvarende galvanisk isolert materiale. Kontakt Digital hvis du er i tvil.

ATTENZIONE

Le installazioni Ethernet possono estendersi per migliaia di metri e collegare diverse centinaia di elementi separati di apparecchiature. Per evitare il rischio di scariche elettriche al momento dell'installazione, è importante che tutte le apparecchiature siano collegate ad un comune sistema di massa come definito nella pubblicazione IEC 364-4-41, clausole 413.1.2 e 413.1.6. Laddove si richieda di collegare l'apparecchiatura fuori dalla principale area di

massa via Ethernet, si devono utilizzare ripetitori su fibra ottica o qualsiasi altro strumento isolato galvanicamente. Per qualsiasi informazione rivolgersi alla sede Digital più vicina.

AVISO

A instalação da Ethernet pode estender-se por milhares de metros e agrupar centenas de itens de equipamento. Para evitar que voltagens perigosas surjam na instalação, é importante que todo o equipamento faça parte de um sistema eléctrico equipotencial comum, tal como definido na publicação 364-4-41 do IEC, cláusulas 413.1.2 e 413.1.6. Onde fôr necessário ligar equipamento fora da área principal de ligação eléctrica equipotencial, através da Ethernet, deverão ser empregues repetidores ópticos ou outras soluções galvanicamente isoladas. Em caso de dúvida, contacte a Digital.

¡PRECAUCIÓN!

Las instalaciones de Ethernet pueden extenderse hasta cientos de metros y a un gran número de equipos. Para evitar tensiones peligrosas en la instalación, es importante que todos los equipos formen parte de un sistema equipotencial común, tal y como se define en las publicaciones del IEC 364-4-41, cláusulas 413.1.2 y 413.1.6. Cuando sea necesario conectar equipos a través de Ethernet fuera del área equipotencial principal, deben emplearse repetidores ópticos u otros elementos aislados galvánicamente del mismo tipo. En caso de duda, le rogamos se ponga en contacto con Digital Equipment Corporation.

VARNING

Ethernet installationer kan vara tusentals meter och koppla ihop hundratals enheter. För att undvika spänningsfara, är det viktigt att alla delar ingår i ett ekvipotentiellt system enligt definitionen i IEC publikationen 364-4-41, klausulerna 413.1.2 och 413.1.6. Då det krävs att utrustning kopplas via Ethernet

utanför det ekvipotentiella systemet, måste optiska förstärkare eller annan galvaniserad isolering användas. Vid eventuella oklarheter, kontakta Digital Equipment AB för rådgivning.

注 意

イーサネットの設置は数千メートルに及んだり、二、三百の設置項目（機器）に及ぶことがあります。

設置に際する危険な電圧の発生を防ぐためには、IEC公報364-4-41の条項413.1.2、および413.1.6に定められているように、すべての機器が共通接地システムに接続されていることが重要です。

共通接地システムに接続できない場所にイーサネットを介して機器を設置する必要がある場合、オプティカルリピータ、または電氣的に分離された手段を講じることが必要です。

ご不明な点は当社にお問い合わせ下さい。

א ת ה ר ה

התקנות ה-ETHERNET משתרעות לפעמים על פני אלפי מטרים, והן עלולות לכלול כמה מאות פריטי ציוד נפרדים. כדי למנוע מתחים חשמליים שעלולים להוות סכנה במתקן, מאד חשוב להקפיד שכל הציוד יהווה חלק ממערכת חשמל משותפת הנמצאת באותו מבנה והמחברת בין מרכיביה, השווים בכח ובפוטנציאל, כפי שהוגדר ב-IEC, דבר דפוס 41-364-4-41 סעיפים 413.1.2 ו-413.1.6. במקומות שבהם נדרש לחבר בין פריטי ציוד מחוץ למבנה הכולל את מערכת החשמל הראשית המשותפת, באמצעות ETHERNET, אזי חייבים להשתמש בציוד אופטי (OPTICAL REPEATERS, BRIDGES) או באמצעים אחרים המבודדים רצף מתכתי. במידה ויתעוררו ספקות, נא לפנות למשרד דיגיטל הקרוב.

2.1 Overview

To install the DEC WANserver 150, you must:

1. Put the server in place (Section 2.2)
2. Check and, if necessary, adjust the voltage setting (Section 2.3)
3. Connect to a power source (Section 2.4)

The rest of this chapter deals with this. When you have worked through this chapter, go on to making connections to networks (see Chapter 3).

To place the DEC WANserver 150 in a rack mounting cabinet, follow the instructions in Chapter 5 and then continue from (Section 2.3).

2.2 Put the Server in Place

Place the server on a desk or table. Digital can also provide you with a wall/partition mounting bracket to mount the server directly onto an office wall or to suspend the server from partitioned office walls. This bracket must be ordered separately. See Appendix D for ordering information.

For office use, place the DEC WANserver 150 hardware in the place you identified in Chapter 1.

2.3 Check the Voltage Switch Setting

1. Make sure the plug on the power cable matches your wall socket. (**Do not** insert the plug into the socket yet.)
2. Select the correct voltage switch setting by following the steps given below. A setting of **240** is correct for voltages in the range 220–240 V ac. A setting of **120** is correct for voltages in the range 100–120 V ac. Make sure that the setting is the same as the one shown on the label.

CAUTION

Using the DEC WANserver 150 with an incorrect voltage switch setting may damage the server.

Step 1: Locate the removable voltage label.

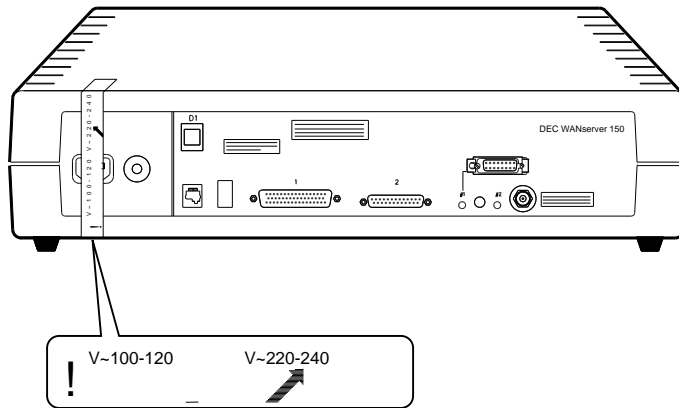

RE_EN06174C_91

Step 2: Remove the voltage label.

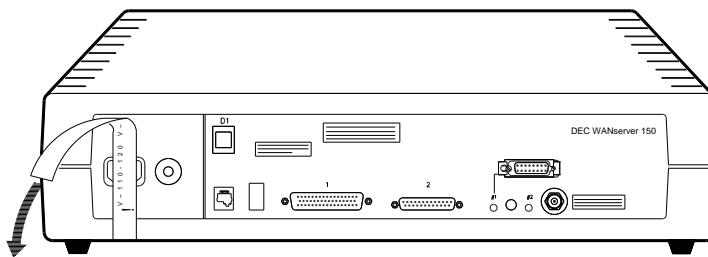

RE_EN06175C_91

Step 3: Check the voltage select switch.

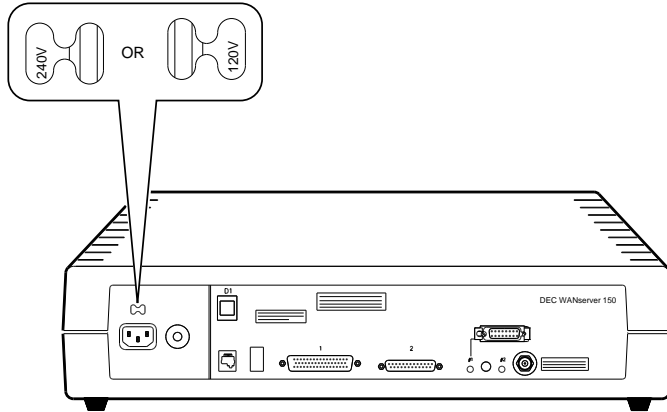

RE_EN06176C_91

Step 4: If necessary, adjust the voltage select switch.

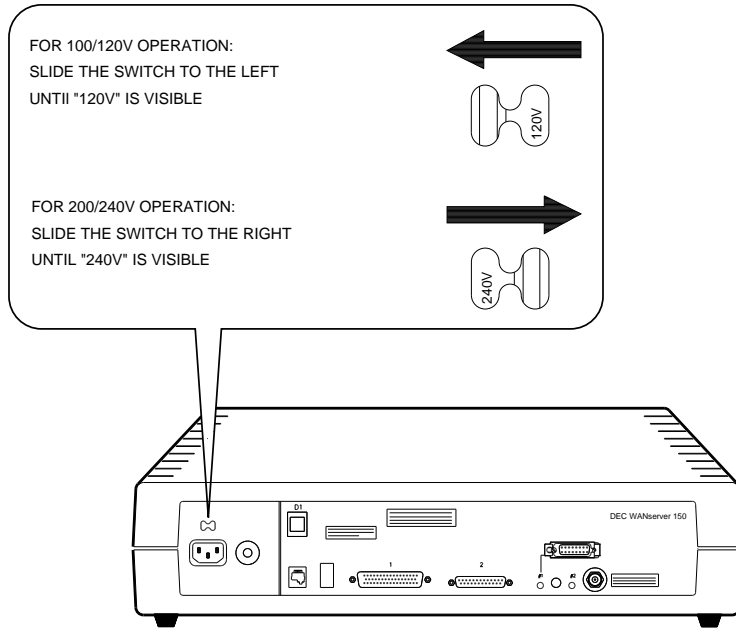

RE_EN06177C_91

2.4 Connect to a Power Source

Test the server hardware before connecting it to the LAN. When the server is first connected to a power source, it does internal checks and sends signals to the Ethernet socket. If you select ThinWire and attach a T-connector with two 50-ohm terminators, as detailed in the following steps, there is no error indicated.

Step 1: Select ThinWire Ethernet.

To select ThinWire Ethernet, press the selector switch. The switch will remain in, and the ThinWire Ethernet LED will light when power is supplied to the server.

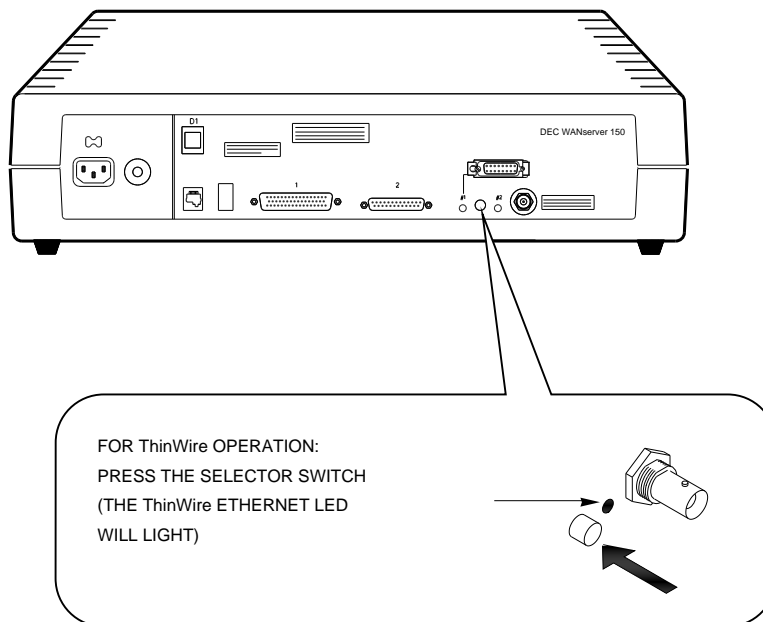

RE_EN06178C_91

Step 2: Connect the ThinWire T-Connector and Terminators.

Insert both of the 50-ohm terminators into the T-connector and insert the T-connector into the BNC connector at the rear of the server. Lock the connector in position by turning the barrel clockwise.

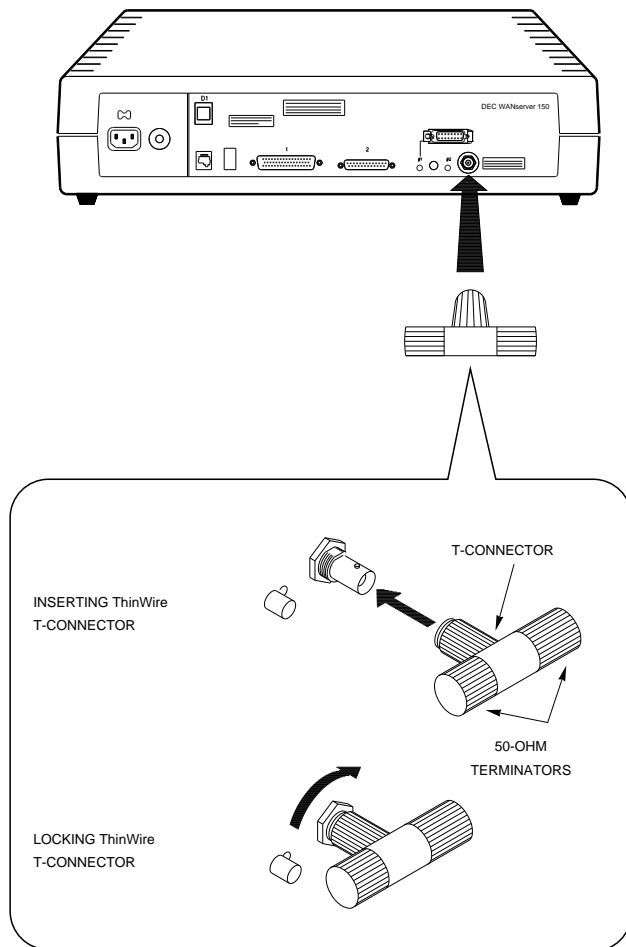

RE_EN06179C_91

Step 3: Connect the Server to a Power Source.

To connect the server to a power source, insert the power cord into the power cord socket and insert the power plug into a power outlet:

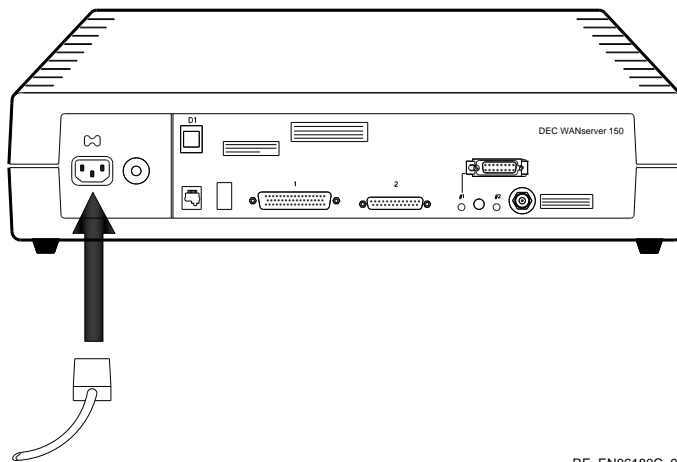

RE_EN06180C_91

Plugging in the server power cord applies power directly to the server and starts the server self-test. The ThinWire LED and the seven-segment display should light up (see the next step).

Step 4: Unplug the power cord and continue.

Watch the seven-segment display:

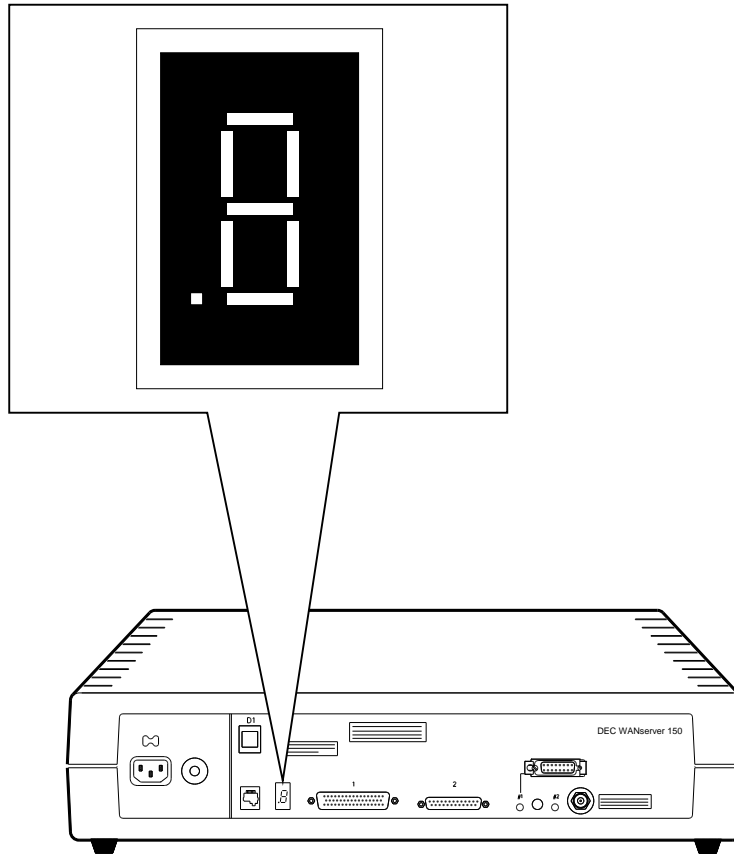

RE_EN06316C_91

When you connect the DEC WANserver 150 to a power source, the server goes through internal checks. The seven-segment display counts down from F to 3 while the server is running these checks. If the count-down stops before reaching 3, or if you have other problems with the installation, see Section 2.5.

When the seven-segment display has counted down to 3 the internal checks are complete. Disconnect the power cord and the T-connector and continue with the installation.

2.5 Basic Installation Troubleshooting

In order to recognize the basic problems that this section deals with, you will need to refer to Figure 2–1, which shows the server controls, indicators, and connectors used by the DEC WANserver 150. They are all on the rear of the server.

Figure 2–1 DEC WANserver 150 Back Panel

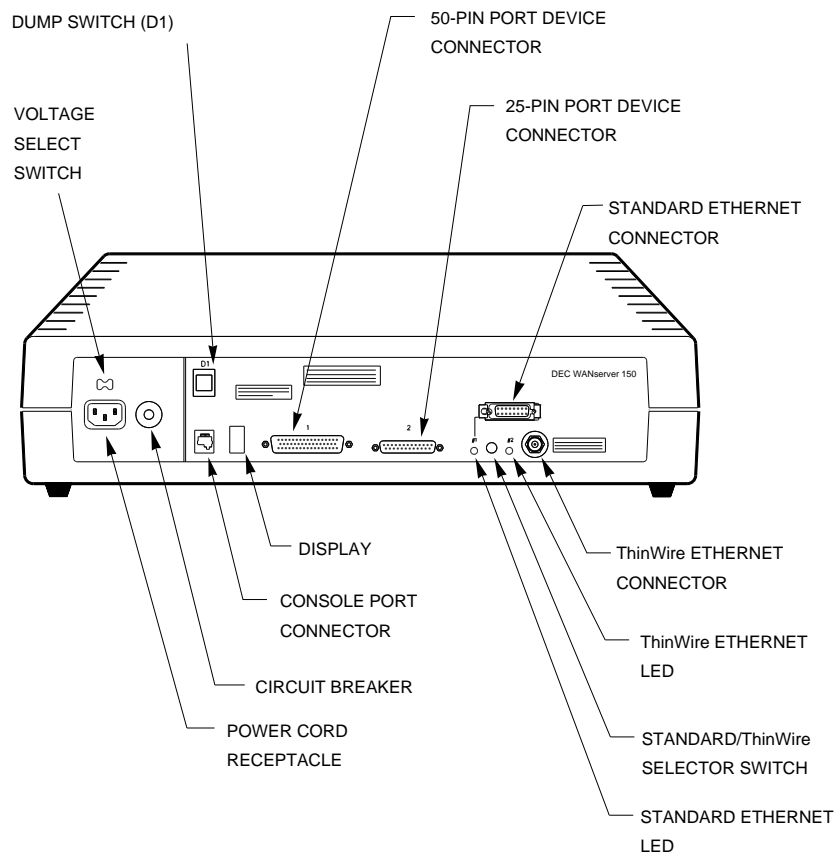

RE_EN06171C_91

If no lights show when you connect power, make these checks:

1. Make sure that the voltage select switch is set to the correct voltage for your country.
2. Secure the power cable at the server and at the wall outlet, and check the fuse in the power cable plug.
3. Check the wall outlet using another appliance or plug the server into another outlet. If power is not available at the wall outlet, check the wall outlet's circuit breaker.
4. Check if the server's circuit breaker (Figure 2-1) has tripped. If it has, press the white button to reset the breaker, and reconnect the power. If the circuit breaker trips more than once, tell the system manager. The server must be returned to Digital for repair or replacement.
5. Check the power cord by substituting another one. If the first is defective, replace it.
6. Ask a competent engineer to run the checks given in Chapter 7.
7. If the DEC WANserver 150 is defective, tell the system manager. The server must be returned to Digital for repair or replacement.

Connecting to Networks

The DEC WANserver 150 connects computers and servers on a Local Area Network (LAN) to all the services that a Wide Area Network (WAN) provides, either through the 25-pin serial port or through the 50-pin serial port or through both. If you use both serial ports your LAN has access to two WANs, at the line speeds noted in Appendix A.

This chapter explains how to connect your DEC WANserver 150 to a network. Section 3.1 explains how to connect your DEC WANserver 150 to a WAN. Section 3.2 explains how to connect your DEC WANserver 150 to a LAN.

When you have made the network connections, your DEC WANserver 150 is already configured with the default values listed in Table C-1. If you want to change these values, you need to attach a console terminal and reconfigure the DEC WANserver 150. Part II describes how to do this.

3.1 Connect Serial Ports

There are two serial ports at the back of the DEC WANserver 150, one that uses a 50-pin D-connector and one that uses a 25-pin D-connector. Both D-connectors are secured using jack screws. Section 3.1.1 shows how to connect to the 25-pin device port. Section 3.1.2 shows how to connect to the 50-pin device port. For cables attached to either port, an adapter must be fitted if the modem or modem eliminator is wired in a certain way. Seek advice from a competent engineer if you are unsure. Part II deals with this.

Safety Warning for UK Installations only

The DEC WANserver 150 has a label regarding the safety requirements of communications modules installed in the United Kingdom. The safety label states:

SAFETY WARNING. See instructions for use.

The following warnings and conditions apply in the UK only:

WARNING

The port indicated by the safety label is not intended to provide electrical and mechanical isolation to satisfy the requirements of BS6301. Connect only apparatus conforming with BS6301 to the device ports¹, or apparatus that has previously been evaluated against British Telecom [Post Office] Technical Guides 2 or 26 and given permission to attach. Other usage will invalidate any approval given to this apparatus.

Connecting apparatus to which this warning applies, whether the ports are so marked or not so marked, may produce hazardous conditions on the network. Seek advice from a competent engineer before making any such connection.

¹ Products complying with OfTel's General Approval NS/G/23/J/100003 may be connected to the DEC WANserver 150 and need not carry the BS6301 warning text or label. **All products supplied by Digital comply with this General Approval.**

3.1.1 Connecting to the 25-Pin Device Port

Step 1: Connect the female connector of the cable to the male connector on the server.

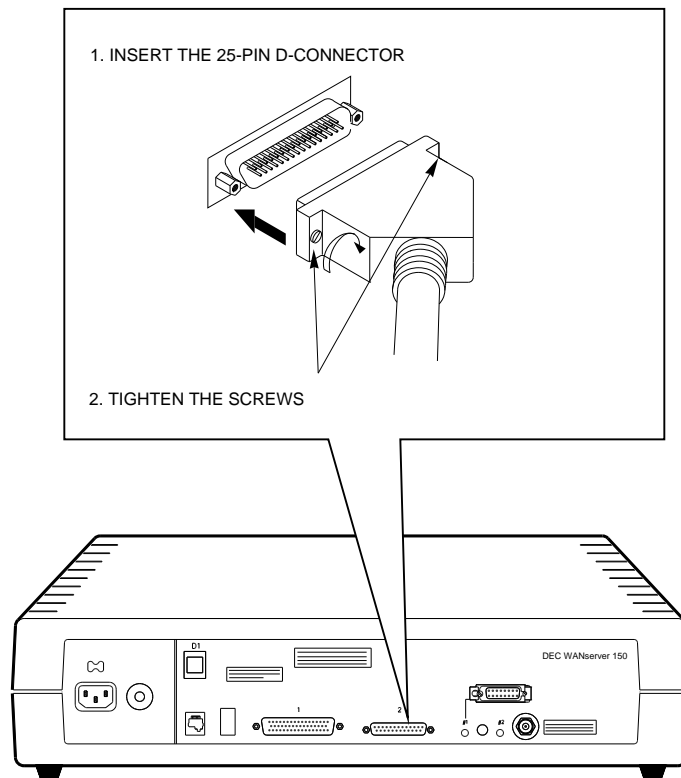

RE_EN06189C_91

Step 2: Connect the male connector of the cable to the female connector on the modem.

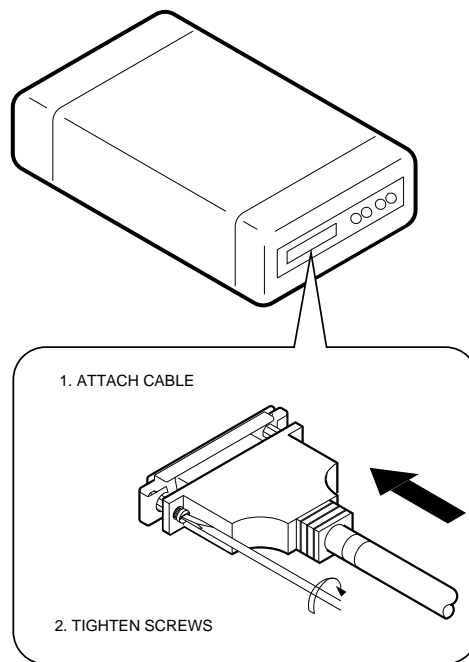

3.1.2 Connecting to the 50-Pin Device Port

To make connections between the 50-pin device port and a modem, you need an adapter cable and an extension cable. Follow these steps:

Step 1: Connect the female connector of the cable to the male connector on the server.

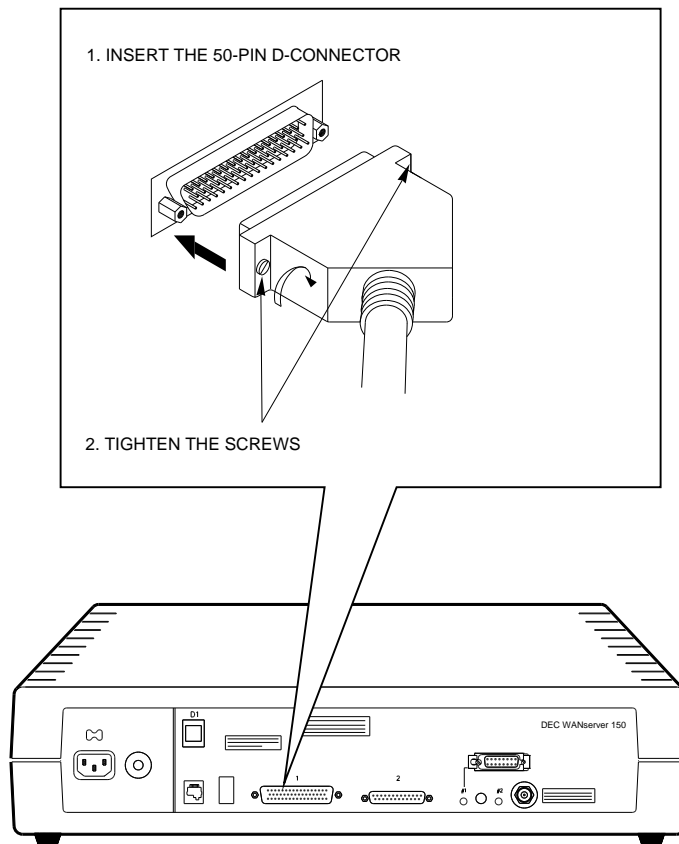

RE_EN06192C_91

Step 2: Connect the adapter cable to an extension cable.

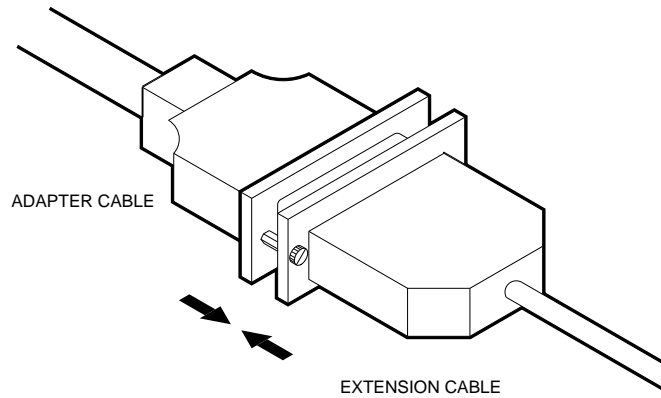

LKG- 3159-89A

Step 3: Connect the male connector of the cable to the female connector on the modem.

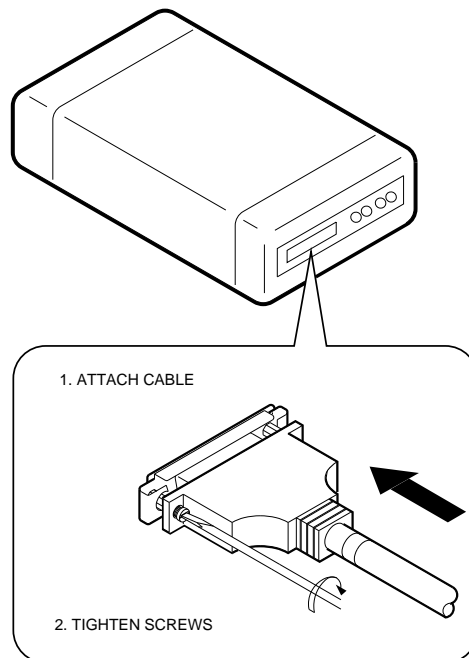

3.2 Connect Ethernet

Whether you are going to connect to Standard or to ThinWire Ethernet, you must use the selector switch as shown in the following diagram. (You will recognize this button—it is the one you used before you first connected the DEC WANserver 150 to a power source. The end of Chapter 2 dealt with this.)

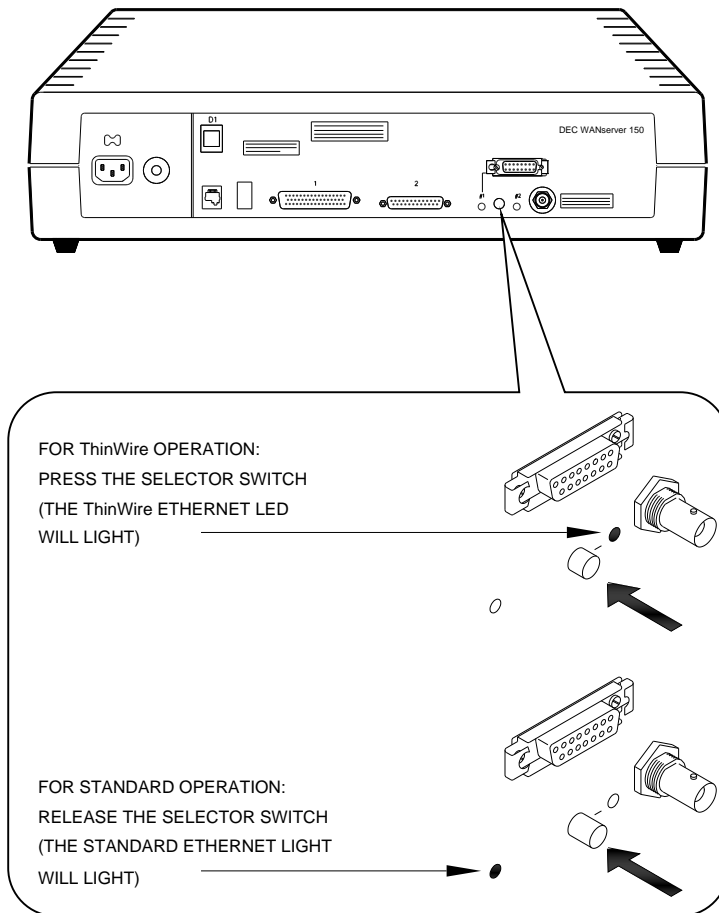

RE_EN06181C_91

To connect to Standard Ethernet, see Section 3.2.1. To connect to a ThinWire Ethernet, see Section 3.2.2.

CAUTION

Do not press the Standard/ThinWire selector switch when the server software is operating as this will cause the system to crash.

3.2.1 Standard Ethernet Connection

Step 1: Verify the Standard/ThinWire switch is in the Out position and the Standard Ethernet LED is on.

Step 2: Power down the server.

Step 3: Unlock the slide latch on the server's Standard Ethernet connector.

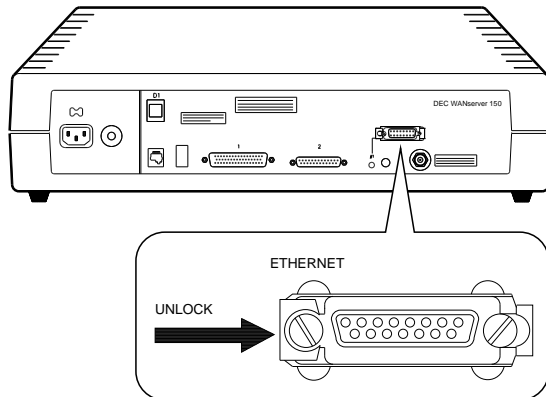

RE_EN06182C_91

Step 4: Connect the transceiver cable.

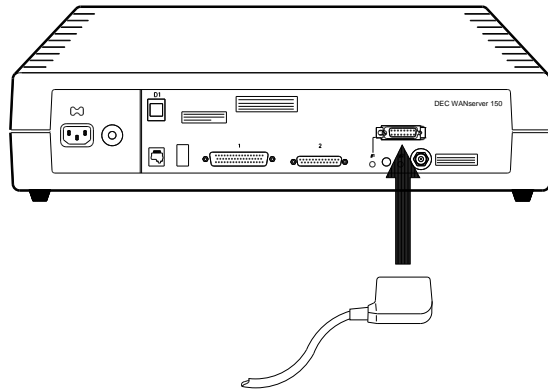

RE_EN06183C_91

Step 5: Lock the slide latch on the Standard Ethernet connector.

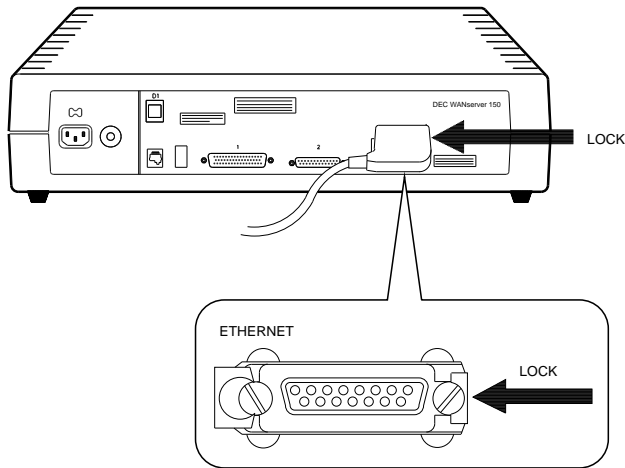

RE_EN06184C_91

Step 6: Power up the server.

3.2.2 ThinWire Ethernet Connection

Step 1: Verify the Standard/ThinWire switch is in the In position.

(Note that you selected ThinWire Ethernet before connecting the server to a power source, so if you have not changed the setting since then the switch will be in the correct position.)

Step 2: Insert the T-connector into the BNC connector at the rear of the server.

Step 3: Turn the barrel of the connector clockwise to lock it.

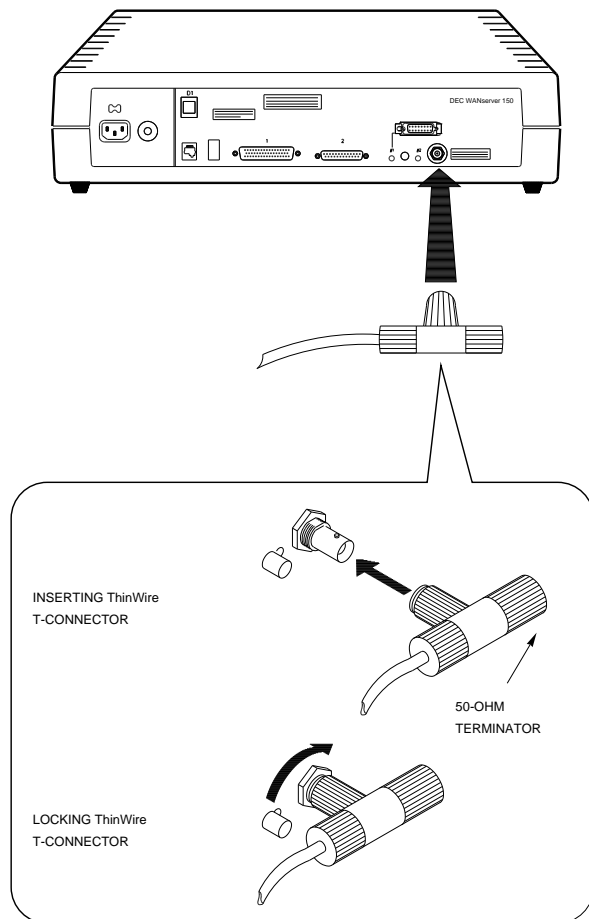

RE_EN06185C_91

Configuring the DEC WANserver 150

The DEC WANserver 150 comes with the default parameter settings listed in Table C-1. If you need to change any of these settings, you must first attach a console. Section 4.1 explains how to do this. Section 4.2 explains how to reconfigure the server.

4.1 Attaching a Console

To attach a console you need a communications lead with a modified modular plug (MMP) fitted at each end. If the console has a 25-pin D-connector, you also need an H8571 adapter. Appendix D contains ordering information.

If the console you want to attach is fitted with a 25-pin male D-connector, follow steps 1 and 2a. If the console you want to attach has a modified modular jack (MMJ) connector, follow steps 1 and 2b.

Step 1: Insert one modified modular plug (MMP) on the cable into the modified modular jack (MMJ) connector.

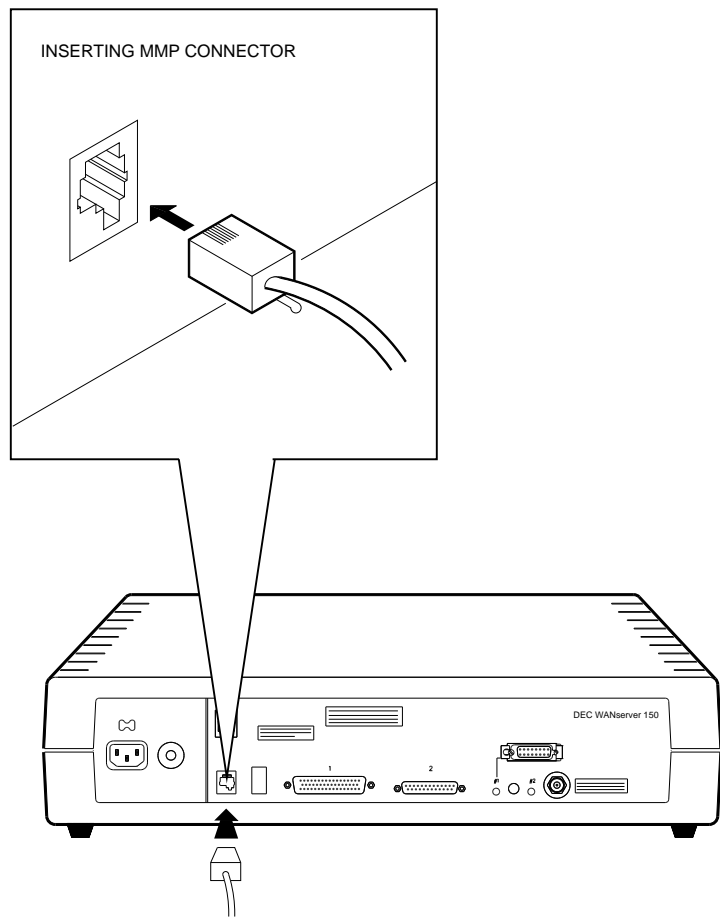

RE_EN06193C_91

Step 2a: Fit the H8571 adapter, and connect the modified modular plug (MMP) on the other end of the cable to the MMJ on the adapter.

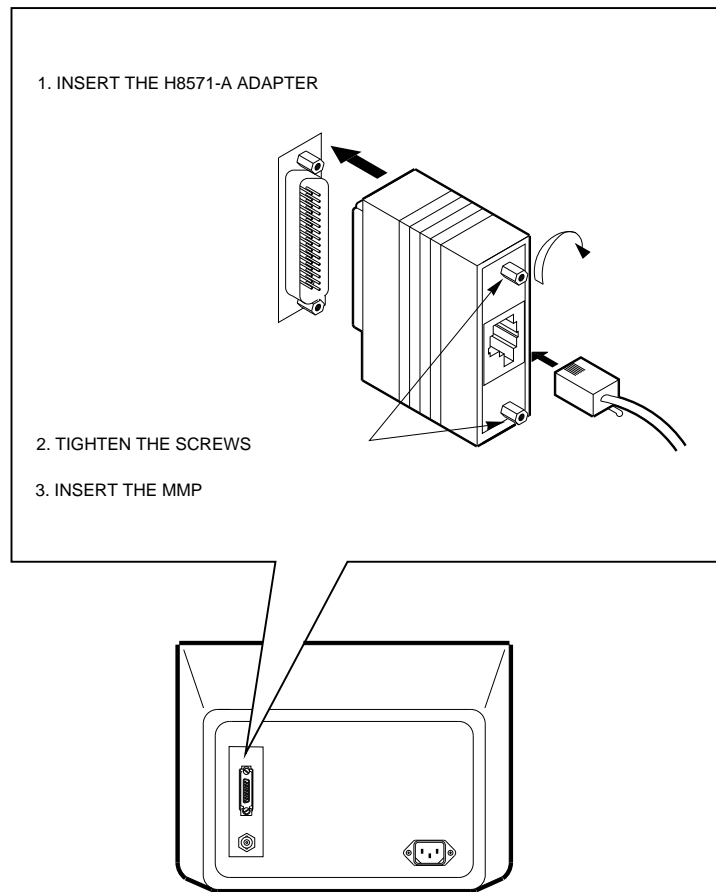

LKG- 3679-89A

Step 2b: Insert the MMP on the other end of the cable into the MMJ connector on the terminal.

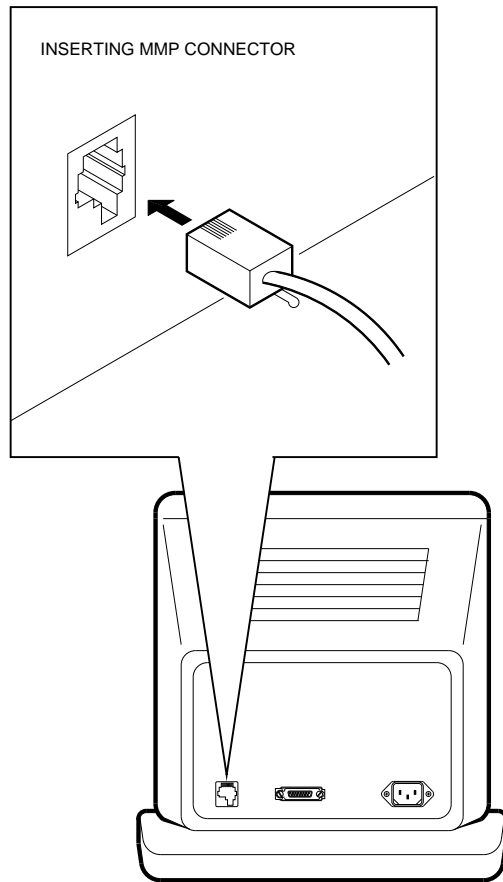

LKG- 3678-89A

Step 3: Configure the terminal.

Following the instructions in the hardware documentation for the terminal, make sure that it has the following setup:

- 9600 baud
- 8 bits
- No parity

4.2 Configuring the Server

Line Speed

You may configure the server to have any one of the following line speed configurations, or lower speeds:

- Port 1 configured for 64 Kbits/s and port 2 disabled.
- Port 1 configured for 64 Kbits/s and port 2 configured for 9.6 Kbits/s.
- Port 2 configured for 19.2 Kbits/s and port 1 disabled.
- Both ports configured for 19.2 Kbits/s.

CAUTION

Do not configure the DEC WANserver 150 to exceed these line speeds.

Configuring Device Ports

To configure the device ports, you use the Bootline Configuration Program (BCP). The BCP has four commands:

- CONFIGURE
- SHOW
- TEST
- CONTINUE

This section deals with the CONFIGURE command. Details of other BCP commands are given in Appendix C. When you have finished using the BCP, you return the server to normal use by issuing the CONTINUE command.

To configure the device ports:

1. Run the BCP by typing `Ctrl/B` in any of these cases:
 - The server passes self-test and is attempting to load (3 or 4 shows on the diagnostic display).
 - You see this prompt:

```
Init -1004- Enter ^B to enter BCP
```
 - You see this prompt:

```
Init -1003- Enter ^P to repeat self-test or ^B to enter BCP
```

For more information on these messages and on the self-test, see Chapter 7.

2. Enter the CONFIGURE command:

```
BCP> CONFIGURE 
```

3. The terminal displays:

```
LINE, NODE [LINE]
```

Indicate you wish to configure a line by pressing

4. The screen shows:

```
(1 2 ) [1]:
```

Select the line you want to configure.

5. The screen shows:

```
(ENABLE, DISABLE ) [ENABLE]:
```

Accept the default by pressing . This enables the port for down-line loading.

6. The screen shows:

```
(MODEM_CONTROL, DATA_LEADS_ONLY) [MODEM_CONTROL]:
```

Select the one you want.

7. The screen shows:

```
(Line Protocol) [DDCMP]:
```

Select the protocol you want.

If you choose HDLC, there are no further prompts.

8. If you choose DDCMP, the procedure continues:

```
(SYNC, ASYNC) [SYNC]:
```

Select the type of communication you want.

If you select SYNC, there are no further prompts.

9. If you select ASYNC, the procedure continues:

```
(300, 600, 1200, 2400  
9600, 4800, 19200) [19200]:
```

Select the line speed you require.

The port is now configured. You can issue any other BCP command. For example, you might want to configure the other port, or return the server to normal service by issuing the BCP command CONTINUE.

Configuring Node Parameters

To configure the node parameters, you also use the Bootline Configuration Program (BCP).

There are two node parameters that you can set with BCP:

- The server password
- Ethernet down-line load enabled or disabled

To configure the node parameters:

1. Run the BCP by typing `Ctrl/B` in any of these cases:
 - The server passes self-test and is attempting to load (3 or 4 shows on the diagnostic display).
 - You see this prompt:

```
Init -1004- Enter ^B to enter BCP
```

- You see this prompt:

```
Init -1003- Enter ^P to repeat self-test or ^B to enter BCP
```

For more information on these messages and on the self-test, see Chapter 7.

2. Enter the CONFIGURE command:

```
BCP> CONFIGURE Return
```

3. The screen shows:

```
LINE, NODE [LINE]
```

Indicate you wish to configure the node by typing NODE and pressing `Return`.

4. When the screen shows:

```
(NI, SERVICE PASSWORD) [NI]:
```

Select the parameter you want to configure.

The procedure continues in one of two ways.

5. If at step 4 you choose NI, the terminal displays:

```
(NI_ENABLED, NI_DISABLED) [NI_ENABLED]:
```

Select the one you want.

If at step 4 you choose to set the password, the terminal displays:

Enter new service password:

Type the password you want to use and press .

The node parameters are now configured. You can issue any other BCP command. Return the server to normal service by issuing the BCP command CONTINUE.

Appendix C contains further reference material about the Bootline Configuration Program (BCP).

Part II

Advanced Installation

Part II gives instructions for rack-mounting, choosing cables, and solving problems.

There are three chapters in Part II:

- Chapter 5 shows how to rack mount the DEC WANserver 150.
- Chapter 6 explains how to make connections to networks and how to fit adapters.
- Chapter 7 describes steps to take in problem solving.

Rack Mounting

WARNING

The following procedure involves the removal of the system covers, and should be performed only by trained service personnel.

ADVARSEL

Følgende procedure involverer fjernelse af kabinetet og bør kun udføres af uddannet servicepersonale.

VAROITUS

Seuraava toimenpide edellyttää laitteiston kansien avaamista, ja sen suoritus on jätettävä koulutetun ylläpitohenkilökunnan huoleksi.

ATTENTION

Faites appel à du personnel qualifié pour effectuer l'opération décrite ci-après.

WARNUNG

Für das folgende Verfahren müssen erst die Abdeckungen des Systems entfernt werden. Dies sollte nur von Servicespezialisten durchgeführt werden.

WAARSCHUWING

De volgende procedure omvat het verwijderen van de systeempanelen en moet alleen door getraind service-personeel worden uitgevoerd.

ADVARSEL

Fremgangsmåten nedenfor medfører at systemdekslene må fjernes. Dette må bare utføres av kvalifiserte fagfolk.

ATTENZIONE

La seguente procedura si riferisce alla rimozione degli involucri, e deve essere attuata esclusivamente da personale qualificato.

AVISO

O procedimento seguinte envolve a remoção das coberturas do sistema, a qual só deve ser efectuada por pessoal devidamente qualificado.

PRECAUCIÓN

El siguiente procedimiento conlleva la retirada de las cubiertas del sistema, y debe llevarlo únicamente a cabo personal del servicio técnico.

VARNING

I nedanstående anvisningar ingår borttagning av systemkåpor, vilket endast får utföras av utbildad servicepersonal.

注意

この章で述べる手順にはシステム・カバーの取り外しも含まれていますが、これはトレーニングを受けたサービス員のみが当たる作業です。

אזהרה

הפרוצדורות המתוארות בפרק זה עוסקות בהסרת פנלים מהמערכת. פעולה זו חייבת להתבצע אך ורק על ידי טכנאי מחלקת השרות.

To mount the server in a rack, follow these steps:

Step 1: Turn the server upside down.

Step 2: Remove the covers.

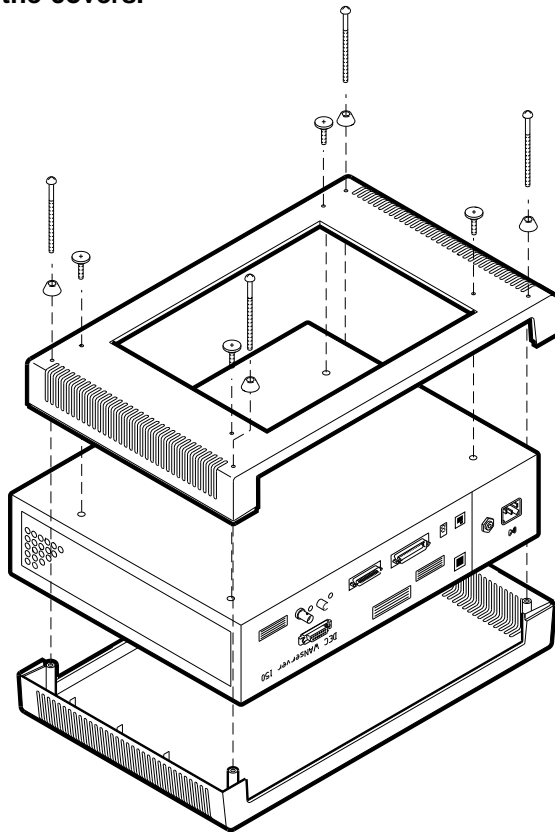

RE_EN06172C_91

NOTE

After you have removed the covers, do not screw the four cover screws back into the (metal) body of the server.

Step 3: Rack mount the server.

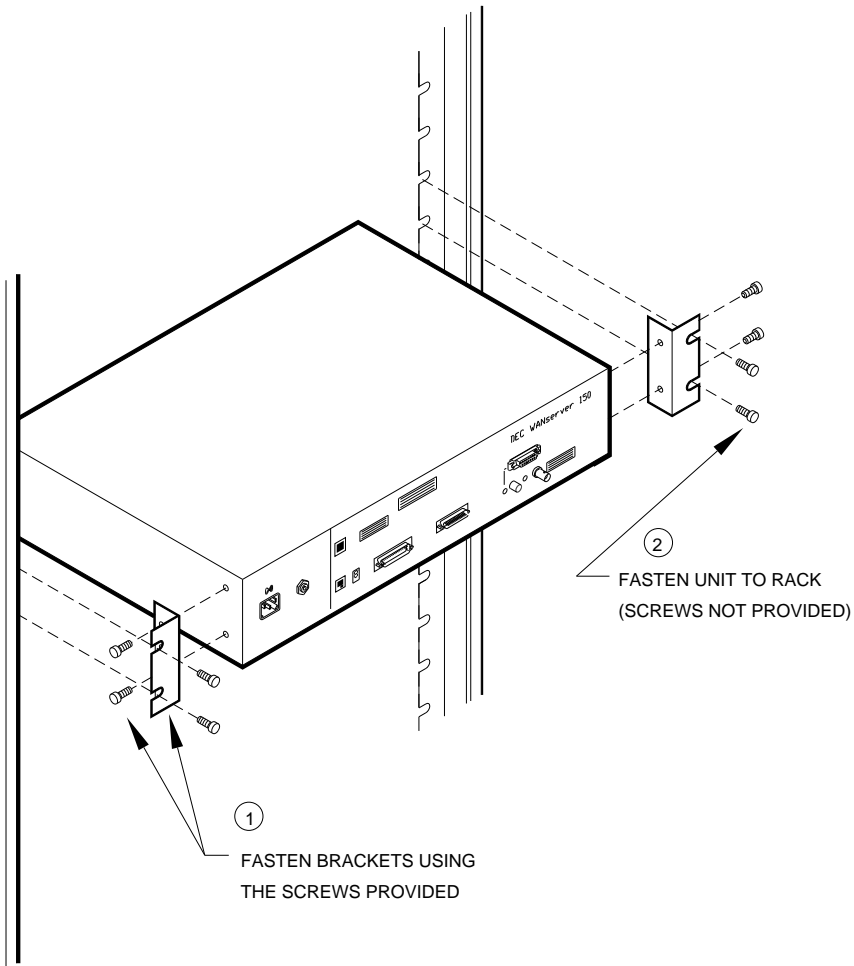

RE_EN06173C_91

Making Connections to Networks and Fitting Adapters

6.1 Connecting to the Local Area Network

You can connect the DEC WANserver 150 hardware unit to either a Standard Ethernet local area network (Section 6.1.1) or a ThinWire Ethernet local area network (Section 6.1.2).

6.1.1 Connecting to a Standard Ethernet

Use a transceiver cable to connect the server to the Standard Ethernet network as shown in Figure 6-1.

Connect the transceiver cable to any of the following:

- A DELNI local area interconnect.
- Another transceiver cable section. This cable can be secured in an Etherjack junction box.
- A transceiver on either a Standard Ethernet coaxial cable for Digital Equipment Corporation baseband networks or a DECOM for Digital Equipment Corporation broadband networks.

Note that the DEC WANserver 150 is compatible with Digital baseband and broadband Ethernet products and with Ethernet and IEEE 802.3 specifications.

Figure 6-1 Standard Ethernet Configuration

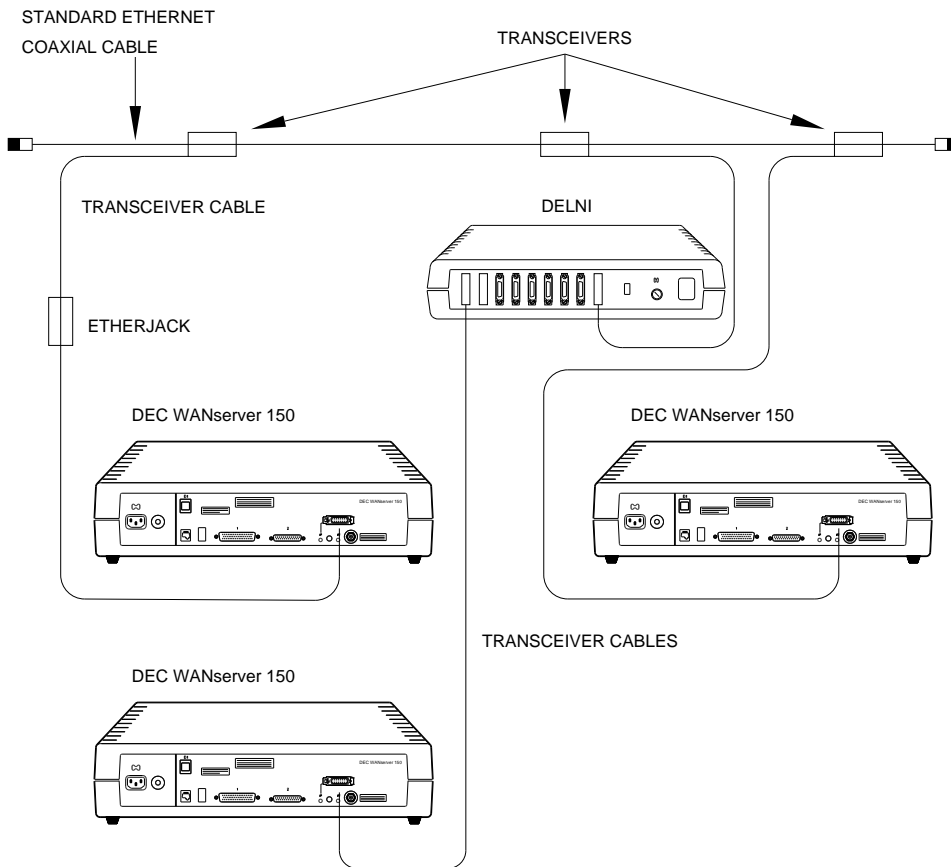

RE_EN06186C_91

6.1.2 Connecting to ThinWire Ethernet

Use a ThinWire coaxial cable to connect the server to the system in either of two ways:

- As part of a standalone ThinWire Ethernet coaxial cable segment
- As part of a DEMPR or DESPR ThinWire Ethernet coaxial cable segment

Figure 6-2 shows servers connected as part of a standalone ThinWire Ethernet segment, and Figure 6-3 shows servers connected as part of a DEMPR ThinWire Ethernet segment.

NOTE

A ThinWire segment must begin and end in a 50-ohm terminator as shown in Figure 6-2.

Figure 6–2 ThinWire Ethernet Standalone Segment

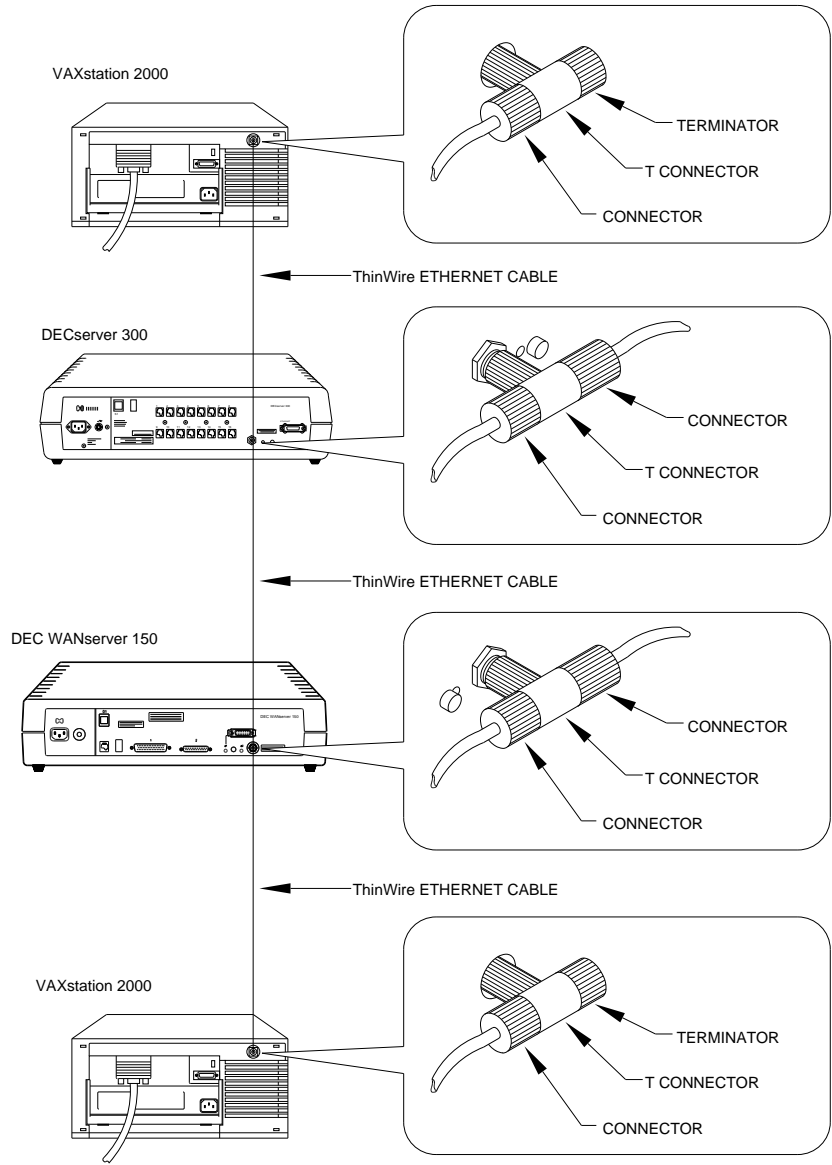

RE_EN06187C_91

Figure 6-3 DEMPR ThinWire Connection

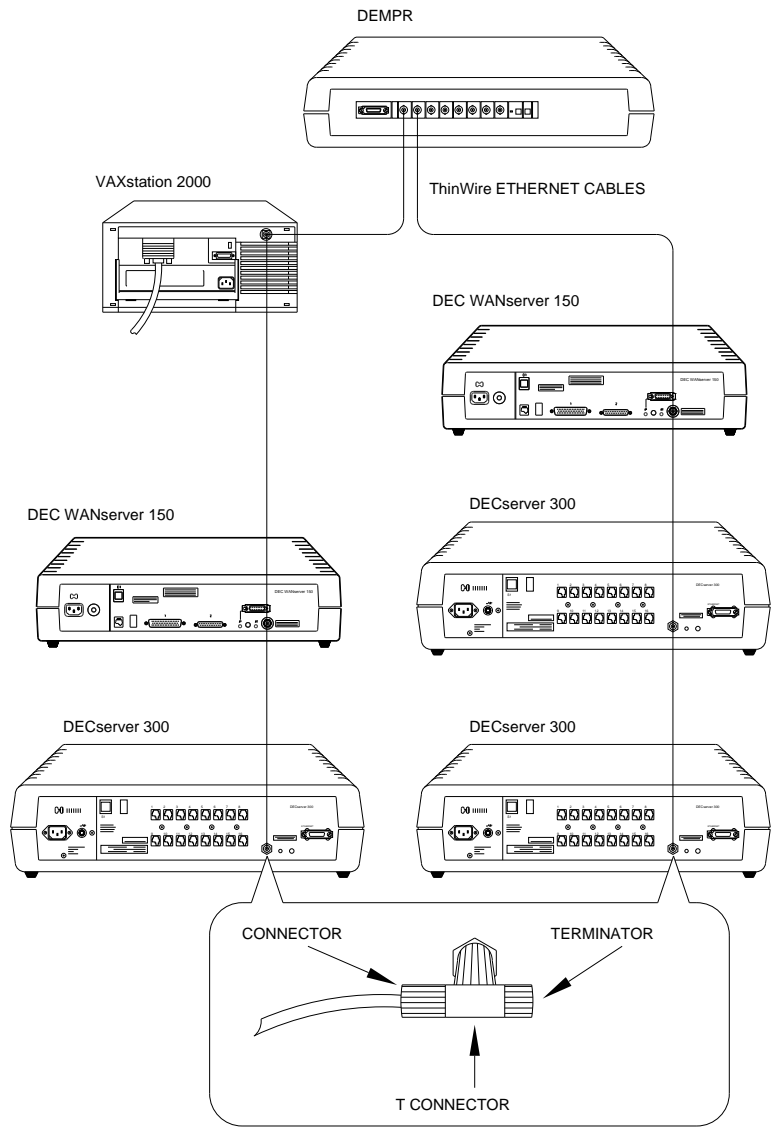

RE_EN06188C_91

NOTE

The DEMPR and DESPR terminate the line internally in 50 ohms so that it is not necessary to use a 50-ohm terminator. However, all unused lines on the DEMPR must have a 50-ohm terminator installed as shown in Figure 6-4.

Figure 6-4 Connections on the DEMPR

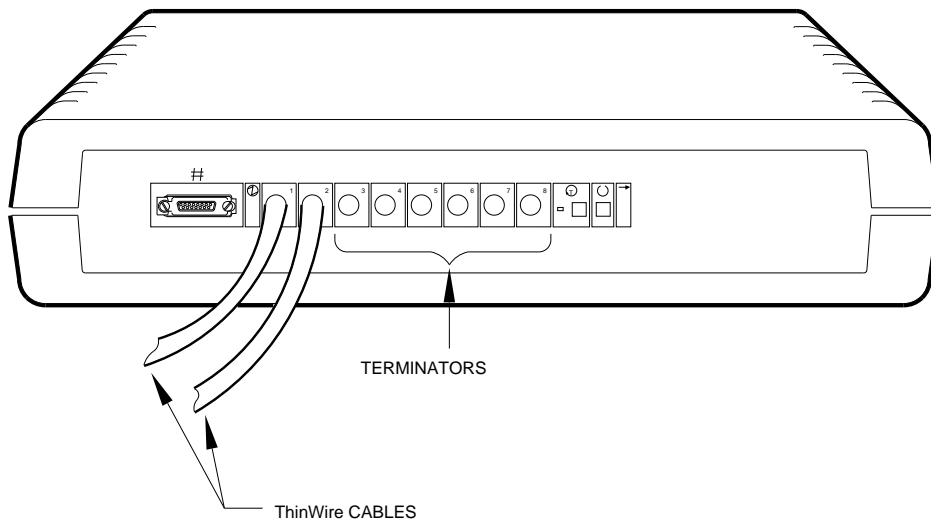

LKG- 2596 -89

For further information on ThinWire Ethernet installation, see the *DECconnect System Planning and Configuration Guide*.

6.2 Adapters

You use a separate adapter cable for each protocol standard with the exception of V.36, which uses the same cable as RS-422-A.

The V.24/RS-232-C adapter (part number 12-27591-01) must be fitted between the device cable and the server if the modem (or modem eliminator) has any of the following:

- A DCE-sourced signal on pin 18
- Signal quality implemented on pin 21
- Data Signal Rate Selector (DCE) on pin 23

WARNING

Failure to fit an adapter could result in damage to the interface module and modem or modem eliminator. If you are not sure what signals the modem or modem eliminator provides, contact Digital Field Service or fit the adapter as a matter of course.

Section 6.2.1 explains how to fit an adapter to the 25-pin port. Section 6.2.2 explains how to fit an adapter between the 50-pin adapter cable and its extension cable.

For further information on cables, refer to Section B.3.

6.2.1 Fitting to the 25-Pin Port

Step 1: Push the adapter into the 25-pin port.

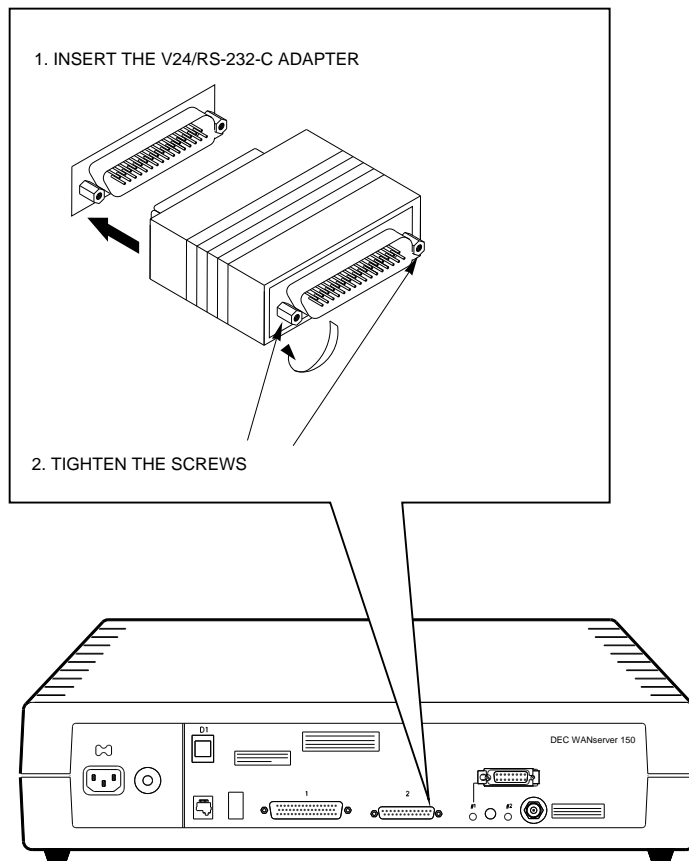

RE_EN06190C_91

Step 2: Plug the cable into the adapter.

1. INSERT THE CABLE

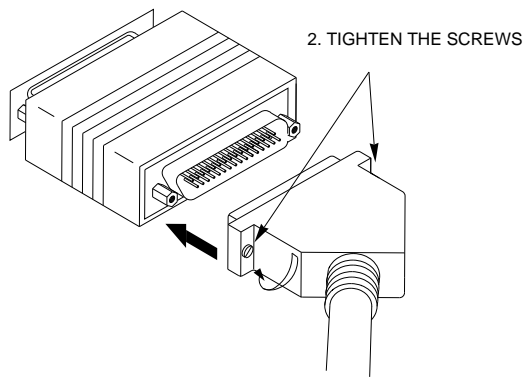

RE_EN06191C_91

6.2.2 Fitting Between the 50-Pin Cables

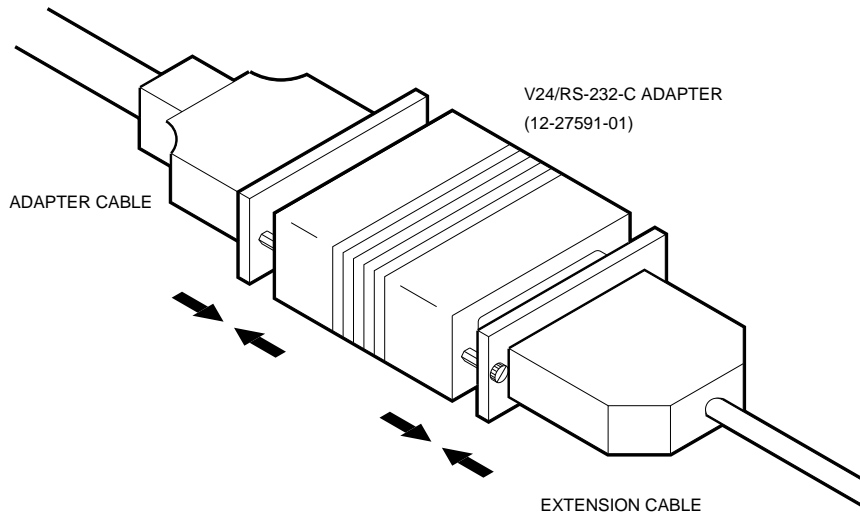

LKG- 3160-89A

Dealing with Problems

This chapter details checks and tests you can make if you have difficulties installing or configuring the DEC WANserver 150. Work through these checks:

1. Check the server hardware meets the specifications listed in Appendix A.
2. Check the correct software is properly installed (Section 7.1).
3. Reinitialize the server as described in Section 7.2.
4. Run the diagnostics procedures as described in Section 7.3.
5. Run the loopback tests described in Section 7.4.

7.1 Software Requirements

Check that the following software requirements are met:

- The distribution software is installed on each load host.
- DECnet Phase IV or Phase IV Plus software is installed on each load host (not required for ULTRIX systems).

The distribution software includes a server image file that is down-line loaded to a DEC WANserver 150. The load host down-line loads the server image to any servers that require it. The image running on the DEC WANserver 150 constitutes the server software that enables the server to perform its functions.

All software must be installed and verified before you can operate the server.

For more information, see the Software Product Description (SPD).

7.2 Reinitialize the DEC WANserver 150

To reinitialize the server with the default values set at the factory:

1. Disconnect power from the server.
2. Hold in the button marked D1, located on the back panel of the server.
3. Reconnect power.
4. When the seven-segment display (Figure 7-1) shows E, release D1.

Table C-1 lists the parameter values set at the factory.

7.3 Running Diagnostics

In order to run diagnostics, you will need a console connected to the DEC WANserver 150. Refer to Section 4.1 for instructions on connecting a console, if one is not already in place.

In all problem solving you will need to refer to the seven-segment display. Figure 7-1 shows the seven-segment display. The diagnostic dot on the display also provides diagnostic information and so does the console.

When you connect the server power cord, the seven-segment display shows the digit 8 for approximately six seconds, followed by a blank display for approximately one-and-a-half seconds.

When self-test runs the display counts down from F through 5 as each block of tests is executed. If a fatal error is detected, the count will stop and the code of the test which has failed will flash. If a nonfatal error is detected, the count will continue and the diagnostic dot will blink. Table 7-1 describes the displays and suggests problem solving steps.

Figure 7-1 The Seven-Segment Display

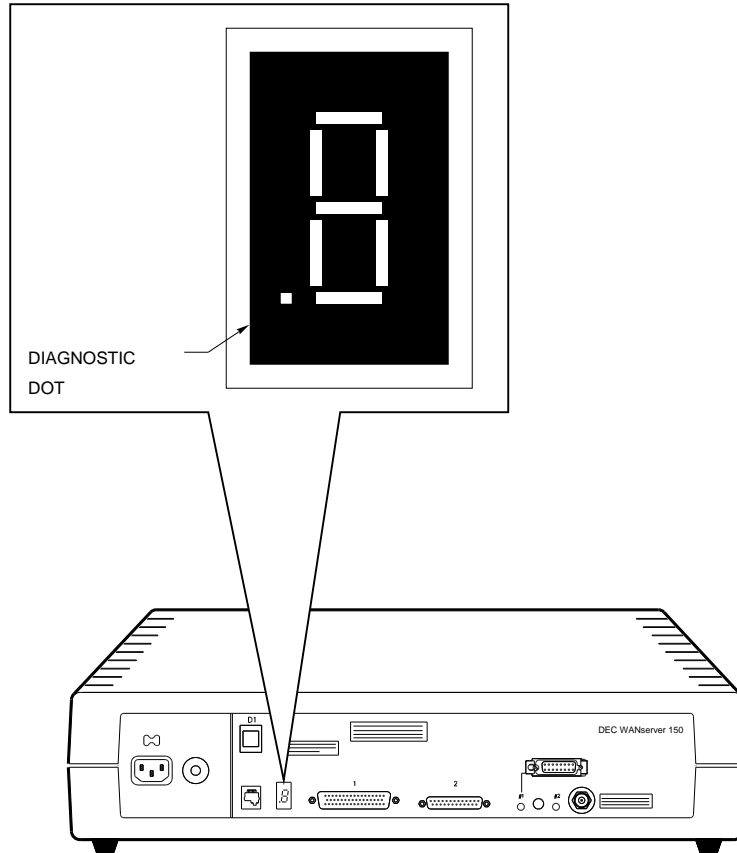

RE_EN06169C_91

Table 7–1 Interpreting the Diagnostic Display

Device	Definition	State	Indication	Action
Diagnostic dot	Diagnostic	On	Self-test passed	—
		Off	Fatal error	See Section 2.5
		Blinking	Error that is not fatal	See Section 7.3.1
Seven-segment display	Status/diagnostic	Off	No power or display broken	See Section 2.5
		Flashing	Fatal error	No corrective action possible. Arrange for return and repair or replacement of the server.
		3	Load request back-off	See Section 7.3.2
		Rotating segment pattern	Server software executing	—

NOTE

On power-up, the seven-segment display will show an 8 and the diagnostic dot will be on for about half a second. Allow about 2 minutes to elapse before determining the state of the display.

When the server passes self-test, it attempts to load the server software from the host and displays 4 on the seven-segment display. The server keeps attempting to load the server software indefinitely. If the attempts are unsuccessful, the display alternates between 4 and 3, with the times between attempted loads getting longer (up to a maximum of five minutes).

7.3.1 Interpreting the Diagnostic Dot

If the diagnostic dot is blinking, an error message appears on the terminal attached to the server. If no terminal is connected, disconnect the server and follow the instructions in Section 4.1. Connect power again, and read the error message that appears on the terminal screen.

If the server passes the self-test with the BNC T-piece fitted and the two terminators connected (with the Standard Ethernet/ThinWire switch set In), then the problem is likely to be in the cables or equipment connected to the server.

The rest of this section lists the error messages, their meaning, and what action to take.

1003

Init -1003- Enter ^P to repeat self-test or ^B to enter BCP

Problem	Solution
None of the ports that are enabled to down-line load the server software has passed self-test.	The server displays this error message with error message 1007 or error message 1008. Refer to those error messages for the correct action.

1004

Init -1004- Enter ^B to enter BCP

Problem	Solution
No port is enabled to down-line load the server software.	Use the Bootline Configuration Program (BCP) to configure a suitable port (see Chapter 4).

1007

Init -1007- Line x, Error detected by self-test

Problem	Solution
The specified port has failed self-test.	There is no corrective procedure. Arrange for return and repair or replacement of the server.

1008

Init -1008- NI External Loopback error detected by self-test

Problem	Solution
The Ethernet port has failed self-test.	Check the Ethernet connections and the setting of the Standard/ThinWire selector switch, as described in Chapter 3. If this does not correct the problem, arrange for return and repair or replacement of the server.

NOTE

If you are not connecting to Ethernet, leave the ThinWire terminators in place and the selector switch set to ThinWire (In). This stops the server from generating error message 1008.

1010

Init -1010- Parameter checksum error detected in NVRAM

Problem	Solution
Self-test has detected a checksum error in NVRAM parameters.	Reinitialize the server, as described in Section 7.2. If this does not correct the problem, notify the system manager (who must arrange for return and repair or replacement of the server).

1012

Init -1012- Modem signal error detected by self-test

Problem	Solution
The specified line has failed the modem signal test routine in self-test.	There is no corrective procedure. Notify the system manager (who must arrange for return and repair or replacement of the server).

7.3.2 Down-Line Loading Problems

If the server has a problem down-line loading, the seven-segment display shows a 3. If no terminal is connected to the server, disconnect the server and follow the instructions in Section 4.1. Connect power again, and read the error messages that appear on the terminal screen.

This section lists the error messages, their meaning, and what action to take.

Down-Line Loading Starts and Fails

The following sequence of messages appears on the console terminal:

```
Init -1101- attempting to locate load host , [format]
Init -1100- Requesting load from host xx-xx-xx-xx-xx-xx [format]
Init -1102- Load failure, timeout
```

Problem	Solution
The host system failed to complete the down-line load to the server.	Copy the message exactly as it appears and notify the network manager.

Down-Line Loading Does Not Start

The following sequence of messages appears on the console terminal:

```
Init -1101- Attempting to locate load host [ISO8802]  
Init -1102- Attempting to locate load host [Ethernet]  
Init -1103- Server will retry operation in x seconds
```

Problem	Solution
Load host or hosts not responding to the server's down-line load request within the allotted timeout period.	Copy the message exactly as it appears and notify the network manager.

7.4 Loopback Tests

If a WAN link fails, you can use the Bootline Configuration Program (BCP) to test the serial ports, using the BCP command LOOP and the appropriate loopback connector attached to the port. Appendix B gives details of loopback connectors, and Appendix D gives ordering information.

To test a device port with a loopback connector, connect the loopback connector to the required port (for example, port 2) and work through the following steps:

1. Run the BCP by typing `Ctrl/B` in any of these cases:
 - The server passes self-test and is attempting to load (3 or 4 shows on the diagnostic display).
 - You see this prompt:

```
Init -1004- Enter ^B to enter BCP
```

- You see this prompt:

```
Init -1003- Enter ^P to repeat self-test or ^B to enter BCP
```

2. Enter the TEST command:

```
BCP> TEST Return
```

3. The terminal displays:

```
(1,2) [1]:
```

Select port 2 by typing 2 `Return`.

4. The terminal displays:

```
(LOCAL_LOOP REMOTE_LOOP EXTERNAL_LOOP INTERNAL_LOOP) [LOCAL_LOOP]:
```

Test the port using a loopback connector by typing EXTERNAL_LOOP `Return`.

An external loopback test is now run on port 2. If the test is passed, the terminal displays:

```
Init -1208- test passed
```

Part III

Appendixes

Part III contains reference material that you may find useful during and after the installation.

There are four appendixes in Part III:

- Appendix A lists standards supported, and gives Physical, Environmental, Electrical and Cabling Specifications.
- Appendix B describes the server's controls and indicators, and gives connector and cable pin descriptions.
- Appendix C gives reference details about the Bootline Configuration Program (BCP).
- Appendix D gives ordering information for related Digital products and services.

A

Standards Supported, and Physical, Environmental, Electrical and Cabling Specifications

A.1 Functions and Standards

Using the DEC WANserver 150 system, you can connect synchronous or asynchronous devices to each other through 25-pin and 50-pin D-connectors, and to a local area network (optional). The DEC WANserver 150 supports these standards:

- EIA-232-D/V.24/V.28
- RS-449, RS-423-A/V.10
- RS-449, RS-422-A/V.11
- V.35
- V.36

Devices that connect to the DEC WANserver 150 system, by means of synchronous or asynchronous ports, include modems, personal computers running DECnet, and larger computers running DECnet. For a list of devices supported by your software, see the Software Product Description.

The DEC WANserver 150 system offers the following features:

- Connections to the Ethernet Local Area Network (LAN) and to a wide area DECnet network for DECnet nodes with synchronous or asynchronous, full-duplex, DDCMP devices, that use any of the standards listed above.
- DECnet routing (for example, message switching and best path analysis) which allows processors more time for applications tasks.
- Reduced and simplified cabling requirements for connecting nodes to the DECnet network.
- Support for dial-in and dial-out modems.
- Support for dial-back security.

A.2 Physical Considerations

Table A-1 shows the physical specifications for the DEC WANserver 150.

Table A-1 Physical Specifications of the DEC WANserver 150

Width	49.3 cm (19.4 in)
Height	11.5 cm (4.5 in)
Depth	31.2 cm (12.3 in)
Weight	4.6 kg (10.1 lb)

A.3 Environmental Considerations

Table A–2 shows the environmental specifications of the DEC WANserver 150.

Table A–2 Environmental Requirements of the DEC WANserver 150

Parameter	Minimum	Maximum
Temperature †		
Operating	5°C (41°F)	50°C (122°F)
Not operating	–40°C (–40°F)	66°C (151°F)
Temperature change per hour		20°C (36°F)
Altitude		
Operating		2438 m (8000 ft)
Not operating	4876 m	(16,000 ft)
Relative Humidity		
Operating (noncondensing)	10%	95%
Not operating (noncondensing)	0%	95%

†If you are using the server above 2.4 kilometers (8000 feet), the temperature specifications decrease by 1.8°C for each 1000 meters (1°F for each 1000 feet).

In addition, the DEC WANserver 150 must be at least 45 centimeters (18 inches) above the floor with 15 centimeters (6 inches) of airspace around the server's air vents and a suitable power source within 1.6 meters (5.5 feet).

A.4 Electrical Considerations

Tables A-3 and A-4 give electrical data for the DEC WANserver 150.

Table A-3 Electrical Requirements

Parameter	DSRVJ-AA	DSRVJ-AB
Voltage range	100-120 V ac (3-wire, single phase)	220-240 V ac
Frequency	50-60 Hz	50-60 Hz
Power	59 W	59 W
Line current	0.8 A	0.45 A

Table A-4 Leakage Current

Parameter	DSRVJ-AA	DSRVJ-AB
Voltage range	100-120 V ac (3-wire, single phase)	220-240 V ac
Frequency	50-60 Hz	50-60 Hz
Leakage Current	0.65 mA	0.95 mA

NOTE

The data in Tables A-3 and A-4 are not specifications, but may be used as a guide to configuration.

A.5 Cabling Requirements

Table A-5 shows the maximum distances for different types of cable used between the server and transceiver, and the maximum length of power cable. Table A-6 shows the maximum cable lengths for asynchronous and synchronous protocols supported by the DEC WANserver 150 at various data rates.

Table A-5 Maximum Cable Lengths

Server to ???	Distance	Cable Type
Transceiver	50 m (164 ft)	BNE3X-XX standard transceiver cable
	12.5 m (41 ft)	BNE4X-XX office transceiver cable
Power outlet	1.8 m (6 ft)	Server power cable
DESPR/DEMPR	185 m (606 ft)	H8243-A cable

Table A-6 Maximum Communications Distances

Line Protocol	Data Rate (Kbits/s)	Cable Length
EIA-232-D/V24	Up to 20	15 m (50 ft)
RS-423-A	Below 1	1200 m (3900 ft)
	20	400 m (1300 ft)
	48	150 m (500 ft)
	64	130 m (400 ft)
	100 (Max.)	85 m (270 ft)
RS-422-A	Below 90	1200 m (3900 ft)
	128	800 m (2600 ft)
	256	400 m (1300 ft)
V.35	48	60 m (200 ft)

Table A-6 assumes the following:

- The V.24 cable capacitance is 50 pF/ft.
- The RS-423-A cable capacitance is 15 pF/ft.
- The RS-422-A cable capacitance is 15 pF/ft terminated with 100 ohm.

A.6 Notes on Cable Configuration

- The maximum length for the extension cable is 25 feet.
- The maximum cable length for V.35 is a recommended figure only.
- ThinWire configurations have the following restrictions:
 - The maximum cable segment length must not exceed 185 meters (606 feet).
 - There must be a 50-ohm terminator at each end of the cable segment unless the cable ends in a DEMPR or DESPR (both these devices have inbuilt 50-ohm terminators).
 - There must be only one ground per cable segment.
 - There must be at least 0.5 meter (19 inches) between T-connectors.
 - The maximum number of stations between terminators must not exceed 30.
 - ThinWire cable segments must not be configured in a loop.
 - ThinWire cable segments must not have any branch segments.

Further information on cabling and configuring of local area networks, and using DECconnect system products, is provided in the *DECconnect System Planning and Configuration Guide*.

B

Server Controls and Indicators, and Connector and Cable Pin Descriptions

In this appendix, Section B.1 gives details of the DEC WANserver 150's controls and indicators. Section B.2 gives details of connectors to use with the DEC WANserver 150, and Section B.3 contains wiring diagrams of the individual cables to help you in problem solving and cable building.

B.1 Server Controls and Indicators

Table B-1 describes the server controls. Table B-2 describes the indicators. Table B-3 gives a brief description of the connectors.

Table B-1 Server Controls

Control	Description
Dump switch (D1)	When the server software is running, press this switch to force the server to dump the contents of its memory to a load host.
Voltage select switch	This switch sets the input voltage to the range required (100–120 V ac or 220–240 V ac).
Circuit breaker	A circuit breaker (press to reset) protects the power supply against excessive current.
Standard/ThinWire selector switch	This switch selects either ThinWire or Standard Ethernet.

Table B–2 Server Indicators

Indicator	Display
ThinWire Ethernet LED	Lights (green) to indicate that the ThinWire Ethernet connector is selected.
Standard Ethernet LED	Lights (green) to indicate that the Standard Ethernet connector is selected.
Display	This is a seven-segment display that provides error and status information. Part II provides further details.

Table B–3 Server Connectors

Connector	Description
25-way — Port device connector	This 25-pin male D-connector connects an EIA-232-D device to the server.
50-way — Port device connector	This 50-pin male D-connector connects a device to the server. The device must support one of the following standards: <ul style="list-style-type: none"> ▪ EIA-232-D/V.24/V.28 ▪ RS-449, RS-423-A/V.10 ▪ RS-449, RS-422-A/V.11 ▪ V.35 ▪ V.36 The device is connected to the port by an adapter cable.
Standard Ethernet connector	This single 15-pin female D-connector connects to a Standard Ethernet local area network using a transceiver cable.
ThinWire Ethernet connector	This single female BNC connector connects to a ThinWire Ethernet local area network using ThinWire cable and a T-connector.
Power cord socket	The server power cord plugs into this socket.
Console connector	This 6-pin Modified Modular Jack (MMJ) connects a console to the server. Part II deals with connecting and using a console.

B.2 Connectors

This section describes the pins for the following DEC WANserver 150 connectors:

- Ethernet transceiver interface
- Device port connectors
- Console port connector

B.2.1 Ethernet Transceiver Interface

The DEC WANserver 150 unit has a ThinWire Ethernet connector and a standard Ethernet connector. The ThinWire Ethernet connector is a 50-ohm, RG58 type, BNC connector with one pin and a shield.

Figure B-1 shows how the pins are numbered on a standard Ethernet transceiver interface connector. Table B-4 lists the signals for the standard Ethernet connector pins.

Figure B-1 Pin Numbers for Standard Ethernet Transceiver

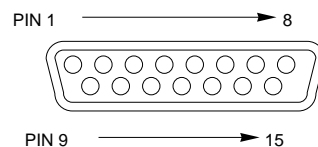

LKG- 2582-89

Table B-4 Pin Descriptions for Standard Ethernet Transceiver Interface

Pin Number	Signal Name
1	Shield
2	Collision presence +
3	Transmit +
4	Reserved
5	Receive +
6	+12 volt power return
7	Reserved
8	Reserved
9	Collision presence -
10	Transmit -
11	Reserved
12	Receive -
13	+12 volt power
14	Reserved
15	Reserved

B.2.2 Device Port Connectors

The following sections describe the two types of connector you use for connecting devices (such as modems and personal computers) to the server.

B.2.2.1 25-Pin D-Connectors

Use the 25-pin D-connector (port 2) to connect devices that support EIA-232-D/V.24/V.28. Figure B-2 shows how the connector pins are numbered and Table B-5 describes the signals on each pin.

Figure B–2 Pin Numbers for 25-Pin D-Connector

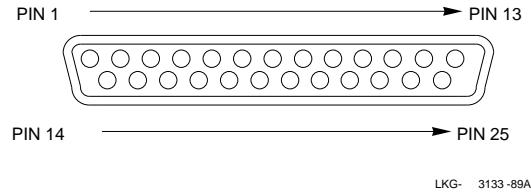

Table B–5 Pin Descriptions for 25-Pin D-Connector

Pin	Signal Description	Signal Name	EIA-232-D	V.24
2	Transmitted data	TXD	BA	103
3	Received data	RXD	BB	104
4	Request to send	RTS	CA	105
5	Ready for sending	CTS	CB	106
6	Data set ready	DSR	CC	107
7	Signal ground	GND	AB	102
8	Data channel received line signal detector	CD	CF	109
12	Data signal rate selector (DCE)	SMI	CI	112
15	Transmitter signal element timing (DCE)	TXCLK	DB	114
17	Receiver signal element timing (DCE)	RXCLK	DD	115
18	Local loopback	LOC LPBK	LL	141
20	Data terminal ready	DTR	CD	108/2
21	Remote loopback	REM LPBK	RL	140
22	Ring indicator	RI	CE	125
23	Data signal rate selector (DTE)	DSRS	CH	111
24	Transmitter signal element timing (DTE)	CLK	DA	113
25	Test indicate	TEST IND	TM	142

Table B–6 Pin Descriptions for 50-Pin D-Connector

Pin	Signal Description	Signal Name	EIA-232-D	V.24	RS-423	RS-422 /V.36	V.35
1	Code Gnd						
2	Code 0 †						
3	Code 1 †						
4	Code 2 †						
5	Code 3 †						
6	Transmitted data A	TXD A				SD	
7	Transmitted data B	TXD B				SD	
8	Transmitted data	TXD	BA	103	SD		
9	Request to send A	RTS A				RS	
10	Request to send B	RTS B				RS	
11	Received data A	RXD A	BB	104	RD	RD	
12	Received data B	RXD B	Earth	Earth	RD	RD	
13	Local loop	LOC LPBK	LL	141	LL	LL	
14	Data signal rate selector (DCE)	SMI	CI	112			
15	Test Indicator	TEST IND	TM	142	TM	TM	
16	Remote loopback	REM LPBK	RL	140	RL	RL	
17	Ring indicator	RI	CE	125	IC	IC	
18	Receiver signal element timing (DCE) A	RXCLK A	DD	115	RT	RT	
19	Receiver signal element timing (DCE) B	RXCLK B	Earth	Earth	RT	RT	
20	Transmit signal element timing (DCE) A	TXCLK A	DB	114	ST	ST	
21	Transmit signal element timing (DCE) B	TXCLK B	Earth	Earth	ST	ST	
22	Transmit signal element timing (DTE)	CLK	DA	113	TT		

†This code is used to identify the adapter cable that is attached.

Table B–6 (Cont.) Pin Descriptions for 50-Pin D-Connector

Pin	Signal Description	Signal Name	EIA-232-D	V.24	RS-423	RS-422 /V.36	V.35
23	V.35 Transmit signal element timing (DCE) A	V35 TXCLK A					114
24	V.35 Transmit signal element timing (DCE) B	V35 TXCLK B					114
25	V.35 Transmit signal element timing (DTE) A	V35 CLK A					113
26	V.35 Transmit signal element timing (DTE) B	V35 CLK B					113
27	V.35 RXD A	V35 RXD A					104
28	V.35 RXD B	V35 RXD B					104
29	V.35 TXD A	V35 TXD A					103
30	V.35 TXD B	V35 TXD B					103
31	V.35 Receiver signal element timing (DCE) A	V35 RXCLK A					115
32	V.35 Receiver signal element timing (DCE) B	V35 RXCLK B					115
33	Data terminal ready	DTR	CD	108/2	TR		
34	Data set ready A	DSR A	CC	107	DM	DM	107
35	Data set ready B	DSR B	Earth	Earth	DM	DM	Earth
36	Ready to send	RTS	CA	105	RS		105
37	Data channel received line signal detector A	DCD A	CF	109	RR	RR	109
38	Data channel received line signal detector B	DCD B	Earth	Earth	RR	RR	Earth
39	Ready for sending A	CTS A	CB	106	CS	CS	106
40	Ready for sending B	CTS B	Earth	Earth	CS	CS	Earth
41	DCE ground	DCE GND	Earth	Earth	RC	RC	Earth

Table B–6 (Cont.) Pin Descriptions for 50-Pin D-Connector

Pin	Signal Description	Signal Name	EIA-232-D	V.24	RS-423	RS-422 /V.36	V.35
42	Test transmit data	TEST TXD	‡	‡			Earth
43	Test RTS	TEST RTS	‡	‡			Earth
44	DTE ground	DTE GND	AB	102	SC	SC	102
45	Data terminal ready A	DTR A				TR	
46	Data terminal ready B	DTR B				TR	
47	Terminal timing A	CLOCK A				TT	
48	Terminal timing B	CLOCK B				TT	
49	Test transmit clock	TEST TXCLK	‡	‡			
50	Data signal rate selector	DSRS	CH	111	SR	SR	

‡This pin is used for testing.

B.2.3 Console Port Connector

The console port connector on the DEC WANserver 150 hardware is a modified modular jack (MMJ). Figure B-4 shows how the pins are numbered on an MMJ connector and Table B-7 lists the signals on the pins.

Figure B-4 Pin Numbers for the Console Port Connector

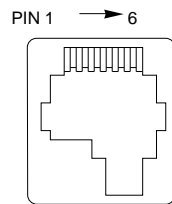

LKG- 2583-89

Table B-7 Pin Descriptions for Serial Communication Interface

Pin Number	Signal Name
1	(Tied to VCC by way of 150 ohm resistor)
2	Txdata
3	Txcommon
4	Rxcommon
5	Rxdata
6	(Tied to GND by way of 3000 ohm resistor)

B.2.4 H3103 MMJ Loopback Connector

Use the H3103 MMJ loopback connector to loop back signals on the configuration port. Figure B-5 is a wiring diagram for the H3103 loopback connector.

Figure B-5 H3103 Loopback Connector—Wiring Diagram

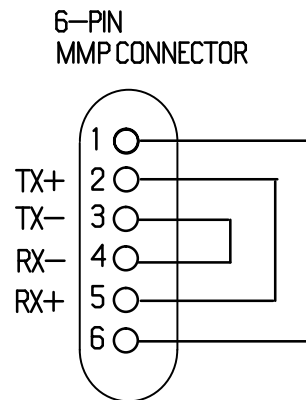

LKG-2589-891

B.2.5 H4080 Turnaround Connector

Use the H4080 turnaround connector in conjunction with a standard Ethernet transceiver cable to loop back the Ethernet signals. Figure B-6 shows an H4080 turnaround connector.

Figure B-6 H4080 Turnaround Connector

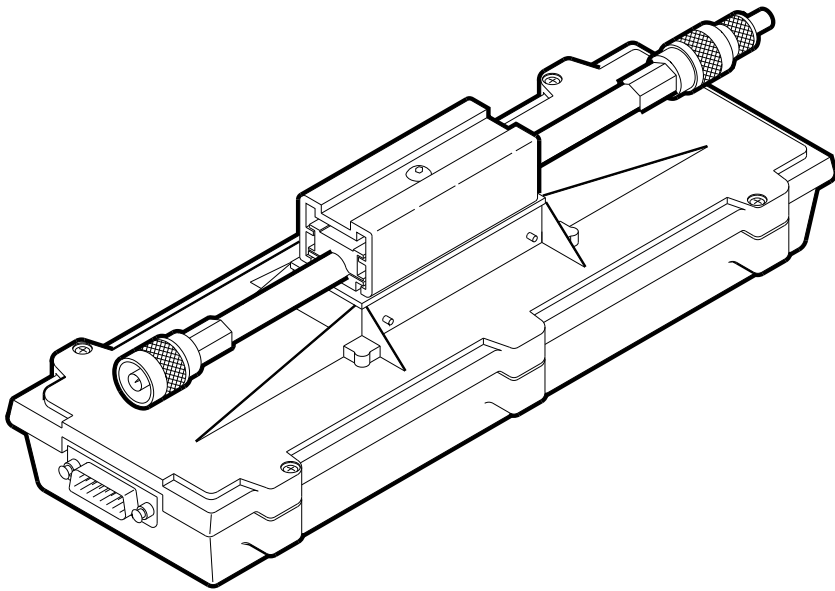

LKG- 2591 -89

B.2.6 Other Loopback Connectors

Use any of four loopback connectors, from the following list, that match your adapter cable combination:

- H3199 — Universal 50-pin
- H3198 — Synchronous line loopback (RS-423-A and RS-422-A)
- H3250 — Synchronous line loopback (V.35)
- H3266 — Synchronous line loopback (EIA-232-D)

B.3 Cable Structure

This section describes the cable structures that are compatible with the DEC WANserver 150 device ports and with the serial configuration port. Wiring diagrams of individual cables are provided for use in troubleshooting and cable building.

B.3.1 Device Cables and Loopback Connectors for Serial Communication 25-Pin D-Connectors

Use the following cables to connect EIA-232-D devices to the DEC WANserver 150 25-pin D-connectors:

- BC17D shielded null-modem cable
This cable is used to directly connect asynchronous devices that use modem signals. See Section B.3.1.1.
- BC22D shielded null-modem cable
This cable is used to directly connect asynchronous devices that use data leads only. See Section B.3.1.2.
- BC22F shielded straight-through modem cable
This cable is used to connect synchronous or asynchronous modems. See Section B.3.1.3.

Use the following loopback connector on the DEC WANserver 150 25-pin D-connector and BC22F cable:

- H3266 loopback connector

See Section B.3.1.4.

Use the following adapter to connect RS-232-C devices to the DEC WANserver 150 25-pin D-connector:

- 12-27591-01, V.24 to RS-232-C adapter

This adapter converts from V.24 to RS-232-C by eliminating the extra signals that exist in V.24. See Section B.3.1.5.

EIA-232-D has the same signals as V.24 so no adapter is necessary.

The following sections contain more information on these adapters and connectors.

B.3.1.1 BC17D Shielded Null-Modem Cable

Use the BC17D shielded null-modem cable to connect asynchronous devices directly to the 25-pin D-connector. The BC17D is a 10-wire cable with a 25-pin D-connector on each end (Figure B-7).

Figure B-7 Wiring Diagram for BC17D Null-Modem Cable

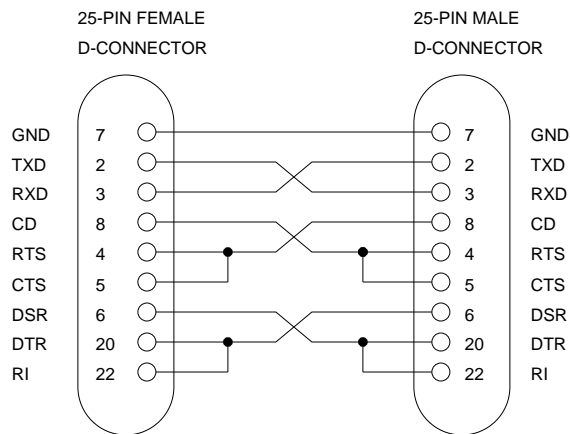

RE_EN06194C_91

B.3.1.2 BC22D Shielded Null-Modem Cable

Use the BC22D shielded null-modem cable to connect asynchronous devices, which use data leads only, to the 25-pin D-connector. The BC22D is a 6-wire cable with a 25-pin D-connector on each end (Figure B-8).

Figure B-8 Wiring Diagram for BC22D Null-Modem Cable

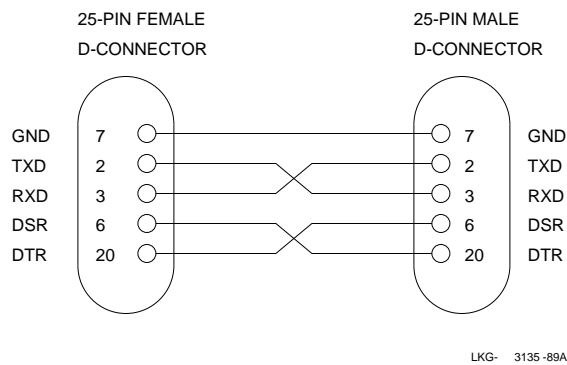

B.3.1.3 BC22F Shielded Straight-Through Modem Cable

Use the BC22F shielded straight-through cable to connect synchronous or asynchronous modems to the 25-pin D-connector. The BC22F is a 25-wire cable with a male, 25-pin D-connector on one end and a female, 25-pin D-connector on the other end (Figure B-9).

Figure B-9 Wiring Diagram for BC22F Straight-Through Cable

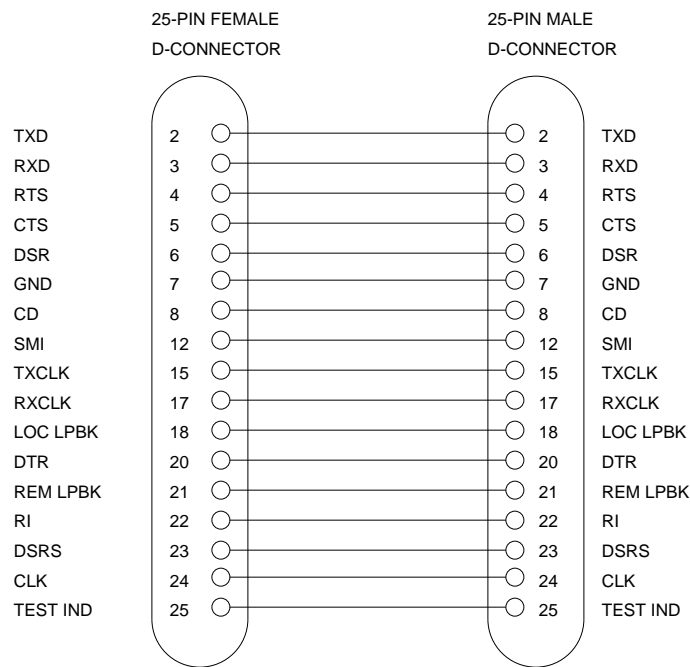

LKG- 3136-89A

B.3.1.4 H3266 Loopback Connector

Use the H3266 loopback connector to test the 25-pin D-connector and the BC22F cable (Figure B-10).

Figure B-10 H3266 Loopback Connector

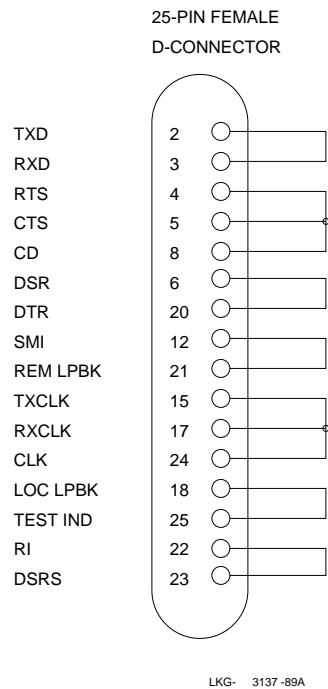

B.3.1.5 V.24/RS-232-C Adapter (12-27591-01)

Use the V.24/RS-232-C adapter (12-27591-01) to convert the 25-pin D-connectors to RS-232-C format. The adapter works by passing through the RS-232-C signals and blocking the others (Figure B–11).

Figure B–11 Wiring Diagram for V.24/RS-232-C Adapter

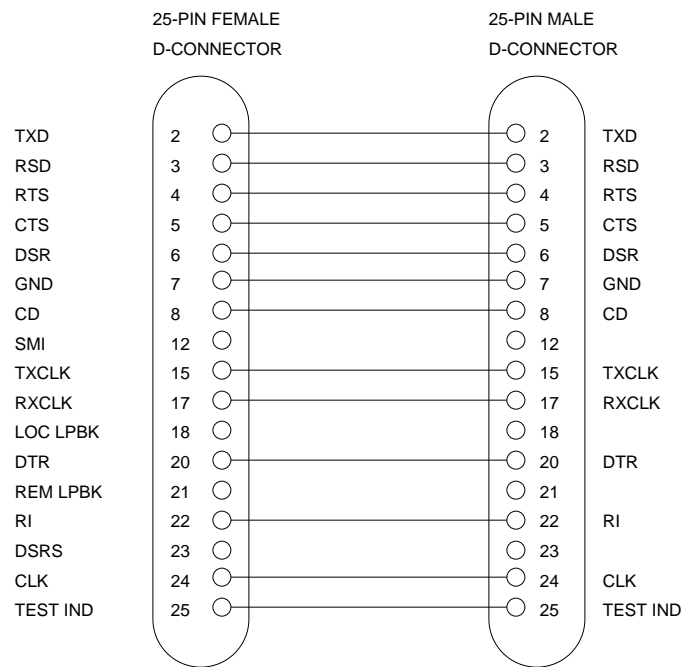

LKG- 3138-89A

B.3.2 Device Cables and Loopback Connectors for Serial Communication 50-Pin D-Connectors

You use an adapter cable and extension cable (see Section B.3.3 for information on extension cables) to connect a device to the 50-pin D-connectors. Choose the adapter cable that matches the standard of the device you wish to connect, from the following list:

- BC19B-02 — Connects DEC WANserver 150 to RS-422-A and V.36 devices
- BC19E-02 — Connects DEC WANserver 150 to RS-423-A devices
- BC19F-02 — Connects DEC WANserver 150 to V.35 devices
- BC23V-02 — Connects DEC WANserver 150 to V.24 devices

B.3.2.1 BC19B-02 Synchronous Line Adapter Cable

Use the BC19B-02 synchronous line adapter cable to connect the DEC WANserver 150 50-pin D-connector to RS-422-A devices. The BC19B-02 is 28-wire cable with a 50-pin, female, D-connector on one end and a 37-pin, male, D-connector on the other end. Figure B-12 shows the wiring diagram.

Figure B-12 Wiring Diagram for BC19B-02 Synchronous Line Adapter Cable

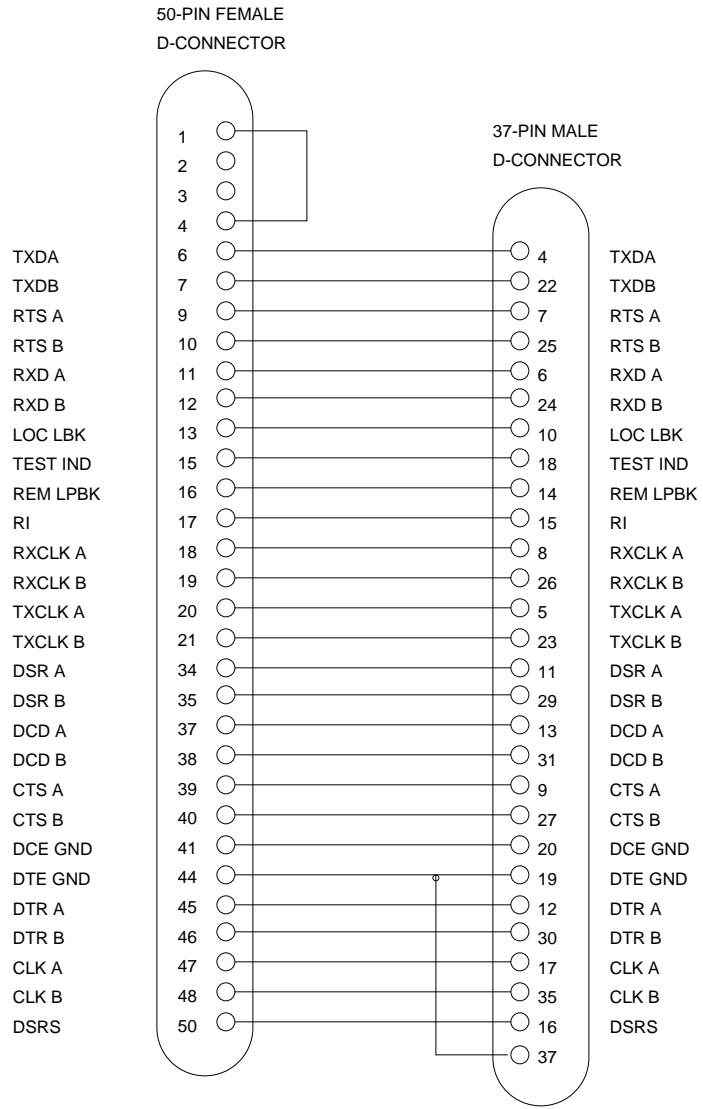

LKG- 3139-89A

B.3.2.2 BC19E-02 Synchronous Line Adapter Cable

Use the BC19E-02 synchronous line adapter cable to connect the DEC WANserver 150 50-pin D-connector to RS-423-A devices. The BC19E-02 is 24-wire cable with a 50-pin, female, D-connector on one end and a 37-pin, male, D-connector on the other end. Figure B-13 shows the wiring diagram.

Figure B-13 Wiring Diagram for BC19E-02 Synchronous Line Adapter Cable

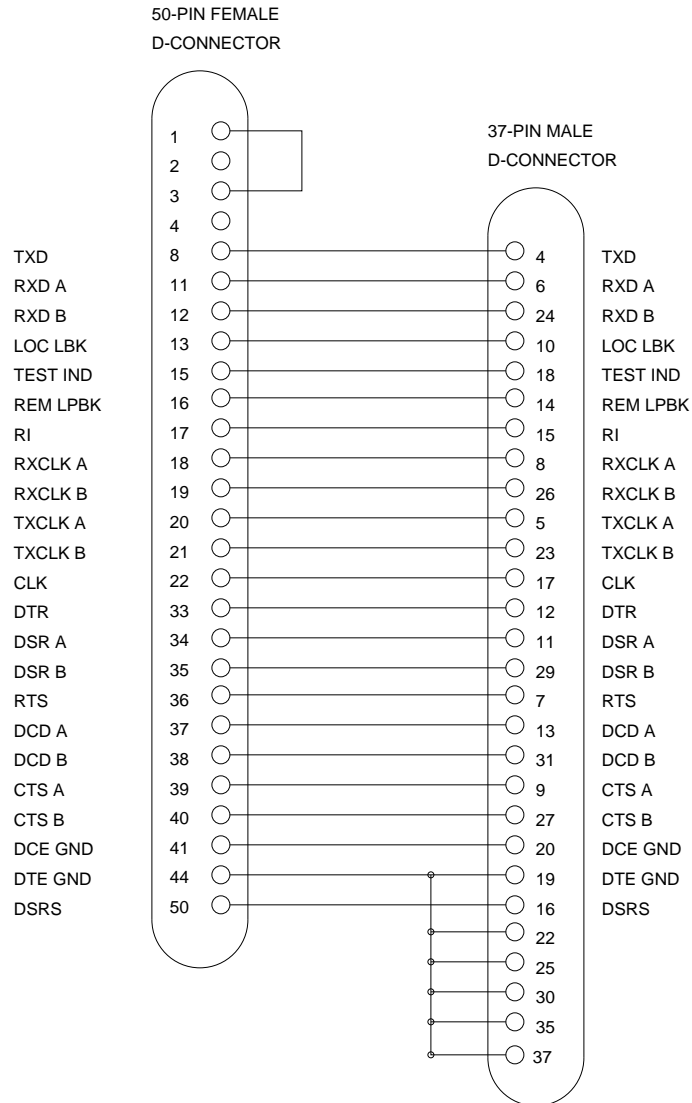

LKG- 3140-89A

B.3.2.3 BC19F-02 Synchronous Line Adapter Cable

Use the BC19F-02 synchronous line adapter cable to connect the DEC WANserver 150 50-pin D-connector to V.35 devices. The BC19F-02 is 16-wire cable with a 50-pin, female, D-connector on one end and a 34-pin, male, square connector on the other end. Figure B-14 shows the wiring diagram.

Figure B-14 Wiring Diagram for BC19F-02 Synchronous Line Adapter Cable

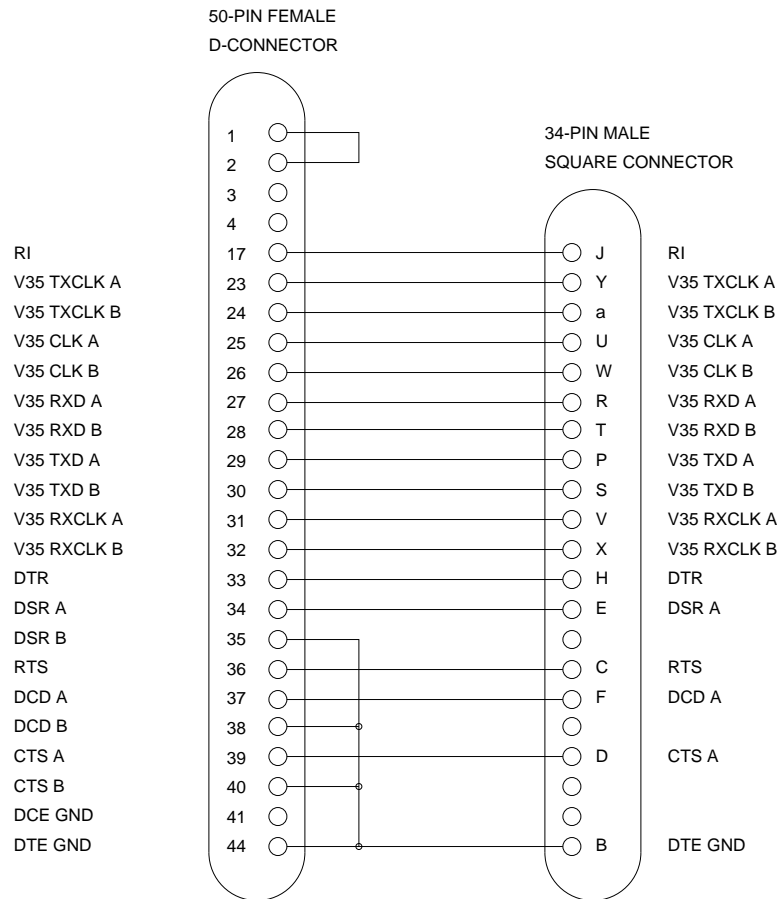

LKG- 3142-89A

B.3.2.4 BC23V-02 Synchronous Line Adapter Cable

Use the BC23V-02 synchronous line adapter cable to connect the DEC WANserver 150 50-pin D-connector to V.24 devices. The BC23V-02 is 16-wire cable with a 50-pin, female, D-connector on one end and a 25-pin, male, D-connector on the other end. Figure B-15 shows the wiring diagram.

Figure B-15 Wiring Diagram for BC23V-02 Synchronous Line Adapter Cable

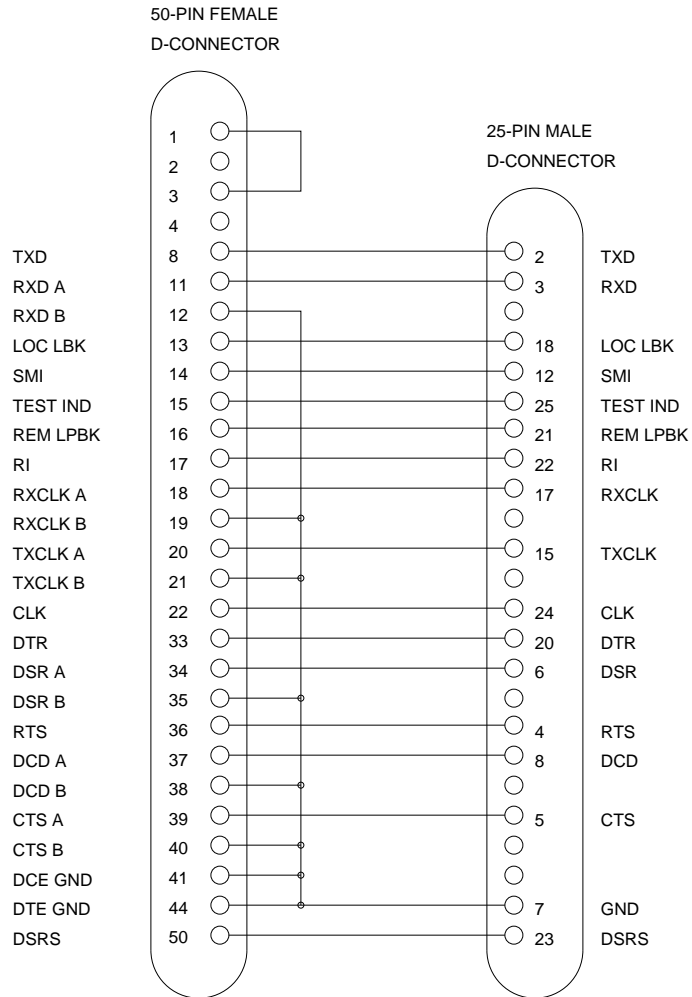

LKG- 3141-89A

B.3.2.5 BC22X-02 BT Kilostream Adapter Cable (U.K. Only)

Use the BC22X-02 BT Kilostream adapter cable to connect the DEC WANserver 150 50-pin D-connector to British Telecom's Kilostream service (through the BC22Z-xx extension cable and the 64 Kbit/s, X.21 interface). The BC22X-02 is 7-wire cable with a 50-pin, female, D-connector on one end and a 15-pin, male, D-connector on the other end. Figure B-16 shows the wiring diagram.

Figure B-16 Wiring Diagram for BC22X-02 BT Kilostream Adapter Cable

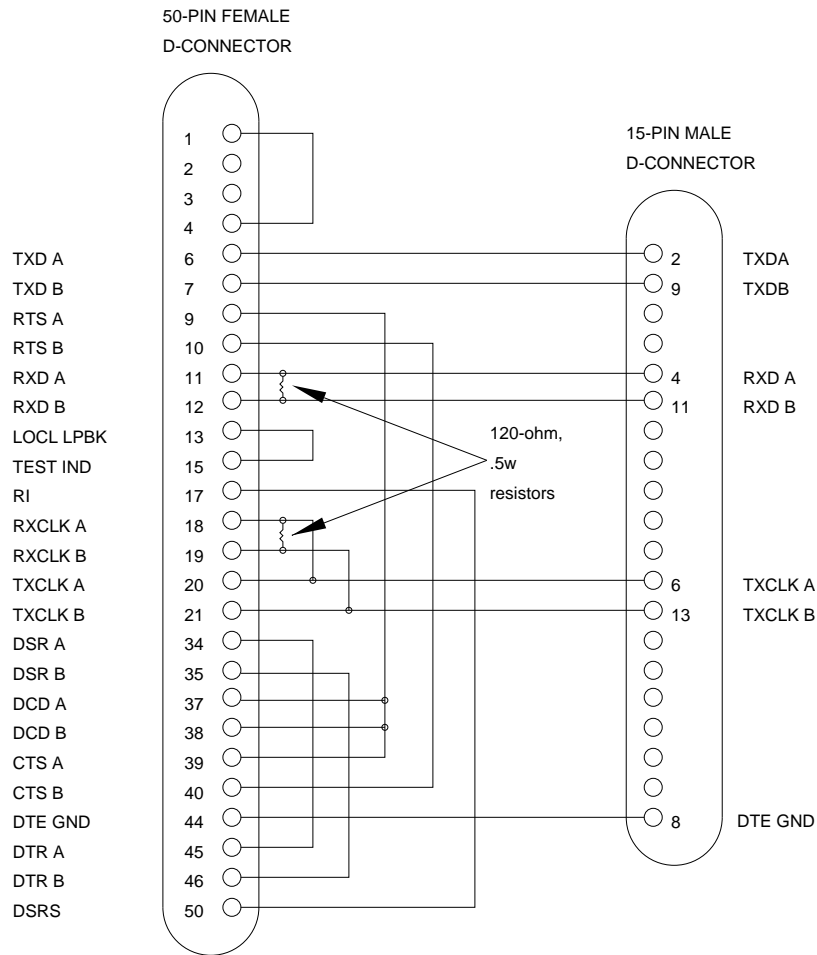

LKG- 3676-89A

B.3.2.6 H3199 Universal Loopback Connector

Use the H3199 universal (50-pin) loopback connector to test the 50-pin D-connector driver and receiver circuits. Figure B-17 shows the wiring diagram.

Figure B-17 Wiring Diagram for H3199 Universal Loopback Connector

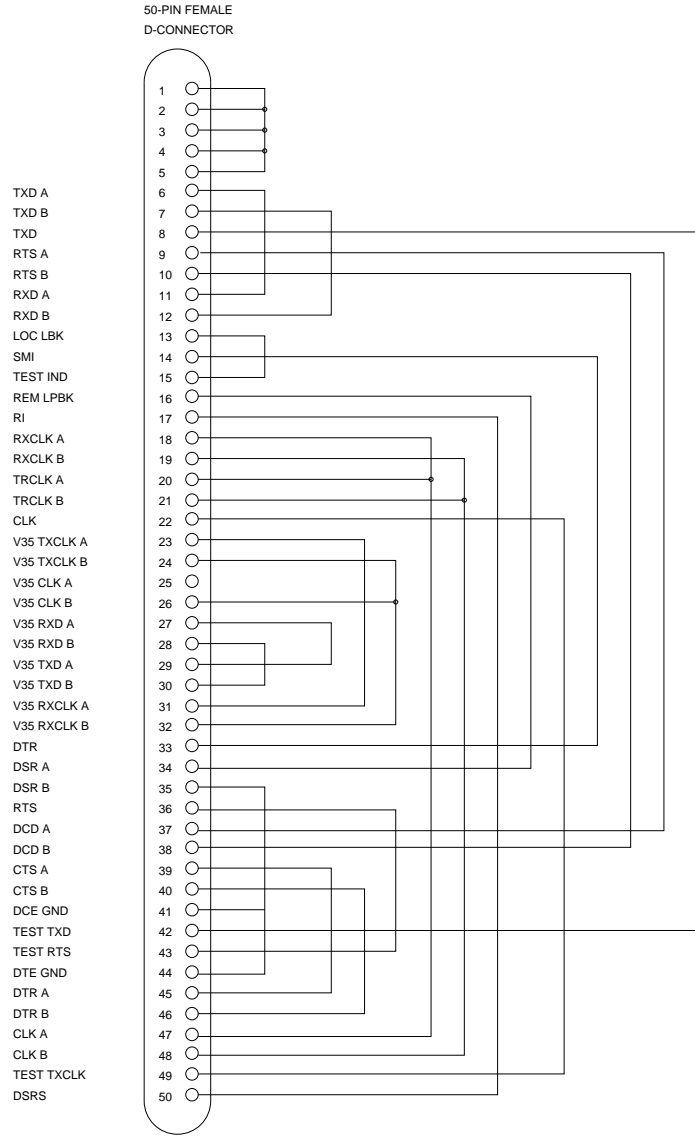

LKG- 3143-89A

B.3.2.7 H3198 Loopback Connector

Use the H3198 (37-pin) loopback connector to test the RS-422-A and the RS-423-A interfaces on the 50-pin D-connector and the RS-422-A and RS-423-A adapter cables. Figure B-18 shows the wiring diagram for the H3198 loopback connector.

Figure B-18 H3198 Loopback Connector

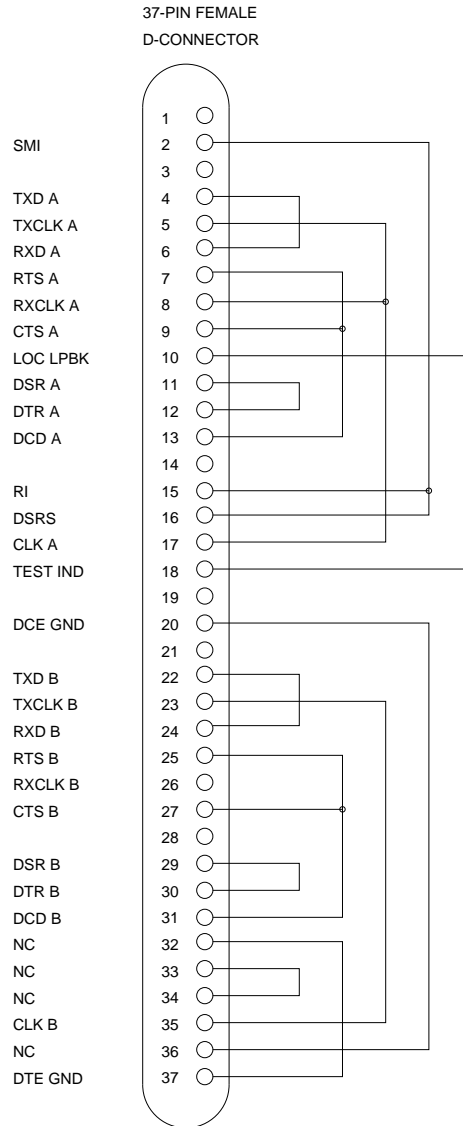

LKG- 3144-89A

B.3.2.8 H3250 Loopback Connector

Use the H3250 (34-pin) loopback connector to test the V.35 interface on the 50-pin D-connector and the BC19F-02 adapter cable. Figure B-19 shows the wiring diagram of the H3250 34-pin loopback connector.

Figure B-19 Wiring Diagram for 34-Pin Loopback Connector

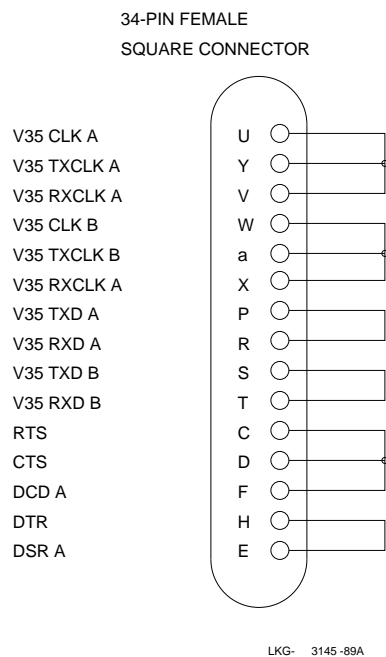

B.3.3 Synchronous Line Extension Cables for Serial Communication

Use the cables in Table B-8 with the line adapter cables.

Table B-8 Synchronous Line Extension Cables

Type	Description
BC55D-XX	Extends BC19B-02 adapter cable (RS-422/V.36)
BC22F-YY	Extends BC19D-02 adapter cable (V.24)
BC55D-XX	Extends BC19E-02 adapter cable (RS-423-A)
BC19L-XX	Extends BC19F-02 adapter cable (V.35)
BC22Z-XX	Extends BC22X-02 BT Kilostream adapter cable

B.3.4 BC16E-xx 6-Conductor DEC Office Cable

Use the BC16E cable to connect a terminal to the configuration port. The BC16E is an unshielded 6-conductor flat cable. This cable is terminated at both ends with an MMP. Figure B-20 shows a wiring diagram of the BC16E-xx.

Figure B-20 Wiring Diagram for BC16E-xx Cable

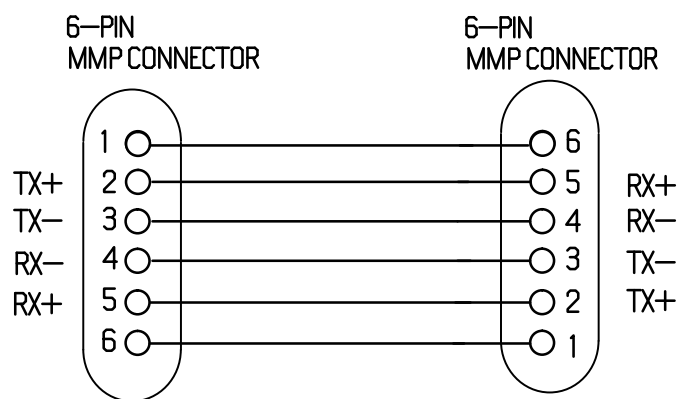

LKG-2586-89I

The Bootline Configuration Program

C.1 BCP Commands

C.1.1 CONFIGURE

Table C–1 lists the line and node parameters for the DEC WANserver 150. Default settings are shown in **bold type**. To change any of these settings, use the BCP.

Table C–1 Line and Node Parameters

Selection	Parameter
LINE ¹ [1 or 2]	ENABLE DISABLE MODEM_CONTROL DATA_LEADS_ONLY DDCMP HDLC SYNC ASYNC ² 300 600 1200 2400 9600 4800 19200 ³
NODE [<i>node_name</i>]	NI SERVICE_PASSWORD ⁴ NI_ENABLED NI_DISABLED ⁵ Ethernet address ⁶

¹BCP refers to ports as lines.

²Only for DDCMP.

³Asynchronous lines are supported at speeds up to 19,200 bits/s. Synchronous lines can run at speeds up to 64 Kbits/s.

⁴Default password: 0.

⁵Only if NI specified.

⁶Cannot be set with BCP. No default value.

C.1.2 SHOW

The format of the SHOW command is:

```
SHOW LINE | NODE
```

C.1.3 TEST

Table C-2 Loopback Parameters

Parameter	Meaning
INTERNAL_LOOP	Runs the self-test loopback tests (not the port connector or its internal wiring).
EXTERNAL_LOOP	Checks either: <ul style="list-style-type: none">▪ A port connector and its internal wiring. For this test, fit a loopback connector to the port.▪ The port connector, its internal wiring, and associated cables. For this test, fit a loopback connector to the cables.
LOCAL_LOOP	Tests as far as the local modem. This test assumes that the local modem recognizes the Local Loop modem signal.
REMOTE_LOOP	Tests as far as the remote modem. This test assumes that the remote modem recognizes the Remote Loop modem signal.

C.1.4 CONTINUE

To return control of the server to the routing firmware issue the CONTINUE command at the BCP prompt:

```
BCP> CONTINUE
```

C.2 BCP Messages

This section lists the messages that are shown on the console.

C.2.1 CONFIGURE Command Messages

If you make an error configuring the node password:

```
Init -1200- Password too long - enter an 8 byte password
Init -1201- Invalid password - enter hexadecimal number
```

If BCP finds a checksum error when you configure or show the node password:

```
Init -1206- Checksum error found in maintenance section
Init -1207- Factory defaults applied to this section
```

If BCP finds a checksum error when you configure or show the node password:

```
Init -1204- Checksum error found in line parameters section
Init -1207- Factory defaults applied to this section
```

If BCP finds a checksum error when you issue an ENABLE, DISABLE or SHOW command for the Ethernet ports:

```
Init -1204- Checksum error found in NI parameters section
Init -1207- Factory defaults applied to this section
```

C.2.2 TEST Command Messages

If the server passes a specified loopback test:

```
Init -1202- Test Passed
```

If the server fails a specified loopback test:

```
Init -1202- Test failed
```

C.2.3 General

If you make a mistake entering command keywords:

```
Init -1203- Unrecognised or ambiguous keyword
```

Ordering Information

D.1 How to Order Hardware

This section lists order codes for products related to the DEC WANserver 150 hardware. See your Digital sales representative to purchase equipment.

D.1.1 Devices and Accessories

The DEC WANserver 150 shipment consists of the following:

- DEC WANserver 150
- *DEC WANserver 150 Installation and Owner's Guide*
- *DEC WANserver 150 Hardware Identification Card*
- BNC T-connector
- BNC 50-ohm terminators (2)
- Country-specific power cord
- Country-specific synchronous cable/adaptor kit
- FTZ Card (Austria and Germany only)
- H3199 loopback connector
- H3266 loopback connector
- Rack mounting kit

Table D-1 Country Codes

Country	Order Code
Australia	DSRVJ-DZ
Austria	DSRVJ-DX
Belgium	DSRVJ-DX
Canada (English and French)	DSRVJ-DA
Denmark	DSRVJ-DD
Finland	DSRVJ-DX
France	DSRVJ-DP
Germany	DSRVJ-DX
Netherlands	DSRVJ-DX
Italy	DSRVJ-DI
Israel	DSRVJ-DT
Japan	DSRVJ-DA
Mexico	DSRVJ-DA
New Zealand	DSRVJ-DZ
Norway	DSRVJ-DX
Portugal	DSRVJ-DX
Spain	DSRVJ-DX
Sweden	DSRVJ-DX
Switzerland (French and German)	DSRVJ-DK
United Kingdom and Eire	DSRVJ-DE
United States	DSRVJ-DA

Table D-2 Accessories

Accessory	Use	Order Code
Ethernet turnaround connector	Testing transceiver and transceiver cable	H4080
Ethernet loopback connector	Looping back signals at the Standard Ethernet port	12-22196-01

Table D–2 (Cont.) Accessories

Accessory	Use	Order Code
Etherjack kit	Covering and securing transceiver cable connections	DEXJK
Wall/partition mounting bracket kit	Mounting the DEC WANserver 150 to walls or office partitions	H039
Rack mounting kit	Mounting the DEC WANserver 150 in standard rack cabinets	H041-AC

D.1.2 Cables and Adapters

Overview

Table D–3 shows the cables and adapters available for connecting devices to the DEC WANserver 150.

Table D–3 Device Cables and Adapters

Description	Order Code
Null modem, 6-wire, fully shielded EIA-232-C/V.28	BC22D-YY ¹
Null modem, 10-wire, fully shielded EIA-232-C/V.28	BC17D-YY ¹
Full EIA-232-C/V.28 modem cable, 25-wire, fully shielded	BC22F-YY ¹
Synchronous line adapter cable, DEC WANserver 150 to RS-422/V.36	BC19B-02
Synchronous line adapter cable, DEC WANserver 150 to V.24	BS23V-02 ²
Synchronous line adapter cable, DEC WANserver 150 to RS-423	BC19E-02
Synchronous line adapter cable, DEC WANserver 150 to V.35	BC19F-02

¹YY represents one of:

- 10: 10 ft (3.1 m)
- 25: 25 ft (7.6 m)
- 35: 35 ft (10.7 m)
- 50: 50 ft (15.2 m)

²Includes BC23V-02 and 12-27591-01 adapter

Table D-3 (Cont.) Device Cables and Adapters

Description	Order Code
BT Kilostream adapter cable, DEC WANserver 150 to BT Kilostream	BC22X-02
Synchronous line extension cable, RS-422/RS-423/V.36	BC55D-XX ³
Synchronous line extension cable, V.35	BC19L-XX ³
X.21 modem extension cable, BT Kilostream service	BC22Z-XX ³
Loopback connector for 25-pin D-connector	H3266
Universal 50-pin loopback connector	H3199
Synchronous line loopback connector (RS-423/RS-422)	H3198
Synchronous line loopback connector (V.35)	H3250
25-pin male to MMJ (modified modular jack) adapter	H8571-A
25-pin female to MMJ (modified modular jack) adapter	H8571-B

³XX represents one of:

- 25: 25 ft (7.6 m)
- 50: 50 ft (15.2 m)
- 75: 75 ft (22.9 m)
- A0: 100 ft (30.5 m)

NOTE

The RS-232-C/EIA-232-D adapter, Digital part number 12-27591-01, is available through your local Digital service office.

Transceiver Cables

Use BNE3x-xx transceiver cable—available in FEP versions—in return air conduits; the same cable is also available in PVC versions, for use in non-environmental airspaces. The large diameter of this cable results in a lower signal cable loss than the smaller diameter office transceiver cable. Two styles of connector are available: a straight connector and a right-angle connector.

The following cables are available:

- BNE3A-xx PVC, straight-connector transceiver cable
- BNE3B-xx PVC, right-angle connector transceiver cable
- BNE3C-xx FEP, straight-connector transceiver cable
- BNE3D-xx FEP, right-angle connector transceiver cable

- BNE3H-xx PVC, straight-connector, 802.3-compliant transceiver cable
- BNE3K-xx PVC, right-angle connector, 802.3-compliant transceiver cable
- BNE3L-xx FEP, straight-connector, 802.3-compliant transceiver cable
- BNE3M-xx FEP, right-angle connector, 802.3-compliant transceiver cable

These cables are available in 5 meters (16.4 feet), 10 meters (32.8 feet), 20 meters (65.6 feet), and 40 meters (131.2 feet) lengths.

Use BNE4x-xx office transceiver cable—available in PVC versions—in non-environmental airspaces. The smaller diameter of this cable makes it ideal for use in office environments; however, the smaller diameter results in a cable signal loss that is four times greater than that of BNE3x-xx transceiver cables. Two styles of connector are available: a straight connector and a right-angle connector.

The following cables are available:

- BNE4A-xx PVC, straight-connector transceiver cable
- BNE4B-xx PVC, right-angle connector transceiver cable
- BNE4C-xx PVC, straight-connector, 802.3-compliant transceiver cable
- BNE4D-xx PVC, right-angle connector, 802.3-compliant transceiver cable

These cables are available in 2 meters (6.6 feet) and 5 meters (16.4 feet) lengths.

D.2 How to Order Software

For a list of software options, see the Software Product Description.

D.3 Other Services

The following sections describe briefly the Digital Equipment Corporation hardware and software options that are available for the DEC WANserver 150 system. For more information, contact your Digital sales representative.

D.3.1 Software Product Service Agreements

Digital offers software product service agreements to support your software.

D.3.2 Training

Digital Educational Services sells training for installation, maintenance, and management of Digital software. Course formats are either seminars or packaged training materials.

D.3.3 Digital On-Site Service

Digital provides on-site service under a service agreement or on a per-call basis. Trained service specialists perform hardware maintenance at your site.

D.3.4 DECmailer

DECmailer allows you to ship the server to a Customer Return Center for repair.

D.3.5 Installation Service

Installation service includes services provided by trained service specialists for successful installation of your DEC WANserver 150 system.

Index

12-27591-01, B-19

A

Adapter, 6-8 to 6-10
different cables for different protocols, 6-8
fitting between 50-pin cable and 25-pin cable, **6-10**
fitting cable to 25-pin adapter, **6-10**
fitting to 25-pin port, 6-9 to 6-10
fitting to 50-pin port, 6-10
needed if Data Signal Rate Selector (DCE) on pin 23, 6-8
needed if DCE-sourced signal on pin 18, 6-8
needed if signal quality implemented on pin 18, 6-8
possibility of damage if not fitted, 6-8
pushing into 25-pin port, **6-9**

B

BC178D, B-15
BC19B, B-20
BC19E, B-22
BC19F, B-24
BC22D, B-16
BC22F, B-17
BC22X, B-28
BC23V, B-26
Bootline Configuration Program, C-1 to C-3
 commands, C-1 to C-2
 messages, C-3
Bootline Configuration Program (BCP)
 See also Configuration
 CONFIGURE command, 4-5 to 4-8
BS6301
 See Serial ports, BS 6301

C

Cable structure, B-14 to B-35
Cabling requirements, A-5 to A-6
Configuration, 4-5 to 4-8
 default values (preset), 3-1, 4-1
 device ports, 4-5 to 4-6
 line speed, 4-5
 need for console, 4-1
 node parameters, 4-7 to 4-8
Configuring the server, 4-1 to 4-8
Connectors, B-3 to B-13
 console port, B-10 to B-11
 Device port, B-4 to B-9
 Ethernet, B-3 to B-4
 loopback for synchronous lines, B-13
 25-pin, B-4 to B-5
 50-pin, B-6 to B-9
Console
 and D-connector, 4-1
 and MMJ, 4-1
 attaching, 4-1 to 4-4
 DEC423 or EIA-232-D compatible, 1-5
 fitting cable into MMJ on terminal, **4-4**
 fitting H8571, **4-3**
 fitting office cable to MMJ in terminal, **4-2**
 set-up parameters, 4-4

D

DEC WANserver 150
 contents of shipment, 1-6
DELNI
 See LAN connection
Diagnostic dot, 7-5 to 7-8
 interpretation table, 7-2

Down-line loading
load host, 7-1
problems, 7-7 to 7-8
seven-segment display shows '4', 7-4

E

Electrical considerations, A-4
Environmental considerations, A-3
Error messages, 7-5 to 7-7
1003, 7-5
1004, 7-5
1007, 7-6
1008, 7-6
1010, 7-6
1012, 7-7
Ethernet, 3-7 to 3-10
Standard, 3-8 to 3-9
ThinWire, 3-10

H

H3103, B-11
H3198, B-32
H3199, B-30
H3250, B-34
H3266, B-18
H4080, B-12
Hardware and software
order of installing, 1-1
Hardware overview, 1-2 to 1-3

I

Installation
preinstallation checks, 1-4 to 1-5
Installation overview, 1-1 to 1-2, 2-6

L

LAN
See Ethernet
LAN connection
See also Network
compatibility with baseband networks, 6-2
compatibility with broadband networks, 6-2
connecting to DELNI, 6-2
connecting to Etherjack, 6-2
DEMPR configuration, 6-6
DEMPR connections, 6-7
DEMPR segment, 6-4

LAN connection (Cont.)
DESPR segment, 6-4
internal terminators in DempR, 6-7
standalone ThinWire segment, 6-5
Standard Ethernet, 6-2
Standard Ethernet configuration, 6-2
terminators, 6-4
ThinWire Ethernet, 6-4 to 6-7
Loopback test
example, 7-9
Loopback tests, 7-9
and BCP, 7-9
and loopback connector, 7-9

N

Network
LAN connection, 6-1 to 6-7

O

Ordering hardware, D-1 to D-5
Ordering services
DECmailer, D-6
Digital On-Site Service, D-6
Installation Service, D-6
Software Product Service Agreements, D-5
Training, D-6
Ordering software, D-5

P

Physical considerations, A-2
Placing server, 2-6
Power, 2-9 to 2-12
connecting to a source, 2-11
disconnecting, 2-12
Preinstallation
identification card, 1-7
unpacking, 1-6 to 1-7

R

Rack mounting
and not reinserting screws, 5-3
putting in rack, 5-4
removing covers, 5-3
Reinitializing server, 7-2
Running diagnostics, 7-2 to 7-8
blinking diagnostic dot, 7-2
errors in self-test, 7-2
seven-segment display, 7-2 to 7-4

S

Serial ports

- BS6301 warning, 3–2
- connecting, 3–2 to 3–6
- connecting 25-pin port to modem, 3–4
- connecting 50-pin adapter cable to extension cable, 3–6
- connecting 50-pin port to modem, 3–6
- connecting to 25-pin D-connector, 3–3
- connecting to 50-pin D-connector, 3–5
- need for 50-pin adapter cable, 3–5
- need for adapter

See also Adapter, 3–2

Server controls and indicators, B–1 to B–2

Seven-segment display, 2–12

Software requirements, 7–1

Standard Ethernet

- connecting transceiver cable, **3–9**
- locking slide latch, **3–9**
- unlocking slide latch, **3–8**

Standards supported, A–1 to A–2

- EIA-232-D/V.24/V.28, A–1, B–2
- RS-449, RS-422-A/V.11, A–1, B–2
- RS-449, RS-423-A/V.10, A–1

RS-449, RS-423-A/V.10, B–2

V.35, A–1, B–2

V.36, A–1, B–2

Support

- DDCMP, A–2
- DECnet routing, A–2
- dial-back, A–2
- modems, A–2
- simplified cabling requirements, A–2

T

ThinWire

- connecting terminators, **2–10**
- selecting, **2–9**

ThinWire Ethernet, **3–10**

- Troubleshooting, 7–1 to 7–9
- power only, 2–12 to 2–14

V

Voltage label, **2–7**

Voltage select switch, **2–8**

Voltage setting, 2–6 to 2–8

