

DECstation 2100/3100

Hardware Installation Guide

September 1989

The information in this document is subject to change without notice and should not be construed as a commitment by Digital Equipment Corporation. Digital Equipment Corporation assumes no responsibility for any errors that may appear in this document.

The software described in this document is furnished under a license and may be used or copied only in accordance with the terms of such license.

Digital Equipment Corporation assumes no responsibility for the use or reliability of its software on equipment that is not supplied by Digital or its affiliated companies.

© Digital Equipment Corporation 1989.
All Rights Reserved
Printed in U.S.A.

USA

This equipment generates, uses, and may emit radio frequency energy. The equipment has been type tested and found to comply with the limits for a Class A computing device pursuant to Subpart J of Part 15 of FCC Rules, which are designed to provide reasonable protection against such radio frequency interference. Operation of this equipment in a residential area may cause interference in which case the user at his own expense will be required to take whatever measures may be required to correct the interference.

The following are trademarks of Digital Equipment Corporation:

DEC	ULTRIX	VMS
DECnet	ULTRIX-32	VT
DECstation	UNIBUS	
DECUS	VAX	
MicroVAX	VAXBI	
MicroVMS	VAXcluster	
PDP	VAXstation	

Contents

Using This Guide	ix
-------------------------------	----

1 Getting Started

Review Site Requirements	1-1
Temperature	1-1
Humidity	1-2
Cleanliness	1-2
Power	1-2
Supplies	1-2
Unpack and Check Your Equipment	1-3

2 Installing the Basic DECstation 2100/3100 Hardware

Set Up the System Unit	2-2
Connect the Keyboard to the System Unit	2-3
Connect the Mouse to the System Unit	2-4
Connect the Ethernet Loopback Connector and Terminators	2-5
To Install the ThickWire Ethernet Loopback Connector	2-6
To Terminate ThinWire Ethernet	2-7
Terminate the SCSI Connector on the System Unit	2-9
Connect the Video Cable to the System Unit	2-11
Set Up the Monitor	2-13
Connect the Video Cable to the Monitor	2-15
To Connect a Video Cable to a Monochrome Monitor ...	2-16
To Connect a Video Cable to a Color Monitor	2-18
Connect the Power Cable and Power Cord	2-20

To Connect the Monitor–System Unit Power Cable	2-21
To Connect the System Unit Power Cord	2-22

3 Starting and Testing the Workstation

Turn On the Monitor	3-2
To Turn On a 15-Inch Monochrome Monitor	3-3
To Turn On a 19-Inch Monochrome Monitor	3-3
To Turn On a 15-Inch Color Monitor	3-4
To Turn On a 19-Inch Color Monitor	3-4
Turn On the System Unit	3-5
If Your System Fails to Turn On	3-6
If Your Monitor Fails to Turn On	3-6
Check the Results of the Power-Up Self-Test	3-7
If a Subtest Is Unsuccessful	3-7
If subtest 7, 6, 5, or 4 fails	3-8
If test 3 fails	3-8
If subtest 2 fails	3-8
If subtest 1 fails	3-8
Arrange for Your Ethernet Connection	3-9
To Find Your Ethernet Station Address	3-9

4 Installing Optional Peripheral Devices

Installing External Storage Devices	4-2
Connecting Expansion Boxes	4-3
To attach only one box	4-12
To attach boxes after the first	4-16
Reading the configuration table	4-16
Setting the SCSI switches	4-18
Connecting boxes	4-19
Installing a Printer	4-24
Installing a <i>Communications Device</i>	4-26

5 Completing the Hardware Installation

Using Ethernet to Access Your Worksystem Software	5-1
Installing Your Worksystem Software on a Hard Disk	5-2
Using a Tape Drive	5-2
To find the unit number of your tape drive	5-3
Using Ethernet	5-4
Where to Go from Here	5-5
To Perform Basic Worksystem Software Installation	5-5

To Tailor Your Worksystem Software to Meet Special Needs	5-5
To Install Application Software Products	5-5

6 Installation Notes for Experienced Installers

Installing the Basic DECstation 2100/3100	6-1
Installing Optional Peripheral Devices	6-3
To Install External Storage Devices	6-3
Connecting an expansion box to the system unit	6-3
Connecting boxes after the first	6-3
To Install a Printer	6-4
To Install a Communications Device	6-4

A Ethernet Hardware Connections

Connecting to a ThickWire Network	A-2
Connecting to a ThinWire Network	A-4
To Connect to the End of a ThinWire Segment	A-5
To Connect Within a ThinWire Segment	A-8

Figures

1-1	The basic DECstation 2100/3100 shipment	1-4
2-1	The on/off switch on the system unit	2-2
2-2	Connecting a keyboard to the system unit	2-3
2-3	Connecting a mouse to the system unit	2-4
2-4	Ethernet loopback connector and terminators	2-5
2-5	Attaching a ThickWire loopback connector to the system unit	2-6
2-6	Attaching terminators to the T-connector	2-7
2-7	Attaching a terminated T-connector to the system unit	2-8
2-8	Removing the plastic cover that protects the SCSI connector	2-9
2-9	Installing a SCSI terminator	2-10
2-10	Video cables	2-11
2-11	Connecting a video cable to the system unit	2-12
2-12	The on/off switch on the monitor	2-14
2-13	Connecting a video cable connector	2-16

2-14	Connecting a video cable to a monochrome monitor	2-17
2-15	Connecting a video cable connector	2-18
2-16	Connecting a video cable to a color monitor	2-19
2-17	Power cable, power cord, and voltage labels	2-20
2-18	Connecting a power cable to a system unit power outlet	2-21
2-19	Connecting the system unit power cord	2-22
3-1	Contrast and brightness icons	3-2
3-2	Turning on monochrome monitors	3-3
3-3	Turning on color monitors	3-4
3-4	Turning on the system unit	3-5
4-1	Expansion boxes	4-2
4-2	Expansion box cables, cord, and terminator	4-3
4-3	Expansion box on/off switch	4-4
4-4	Removing the SCSI terminator	4-5
4-5	ID switch setting for the tape drive	4-6
4-6	ID switch setting for the hard disk drive	4-7
4-7	ID switch setting for the optical compact disc drive	4-8
4-8	Attaching a system unit-expansion box cable to the SCSI connector on the system unit	4-9
4-9	Attaching a system unit-expansion box cable to the SCSI connector on an expansion box	4-10
4-10	Closing the wire brackets	4-11
4-11	Terminating an expansion box	4-12
4-12	Connecting an expansion box power cord	4-13
4-13	Turning on an expansion box	4-14
4-14	Sample configuration display	4-16
4-15	Connecting an expansion box to another expansion box	4-19
4-16	Terminating the final expansion box	4-21
4-17	Connecting the power cord	4-22
4-18	Connecting a printer to the system unit	4-25
4-19	Connecting a communications device to the system unit	4-27
5-1	Sample configuration display	5-3
A-1	Connecting the ThickWire ethernet cable	A-3
A-2	Removing a Terminator from the T-Connector	A-5
A-3	Connecting the ThinWire Cable to the T-Connector.....	A-5
A-4	Connecting one ThinWire cable.....	A-6
A-5	Removing the Terminators from the T-Connector	A-8
A-6	Connecting the ThinWire Cables to the T-Connector.....	A-8
A-7	Connecting two ThinWire cables.....	A-9

Tables

1	Conventions Used in This Guide	ix
4-1	SCSI ID Switch Settings	4-18

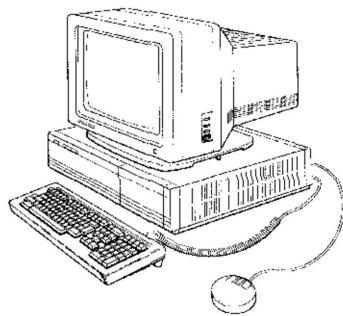

Using This Guide

To install your new DECstation 2100/3100 workstation, follow the instructions in this guide.

If you are a novice installer, read Chapters 1 through 6.

If you are an experienced installer, turn to Chapter 6. For more detailed information about any procedure, refer to the table of contents.

Table 1. Conventions Used in This Guide

Convention	Use
Monospace type	Anything that appears on your monitor screen is set in monospace, like this.
Boldface type	Anything you are asked to type is set in boldface, like this.
	<i>Note:</i> All commands typed at the console level are case sensitive. The workstation does not recognize uppercase and lowercase letters as the same input.

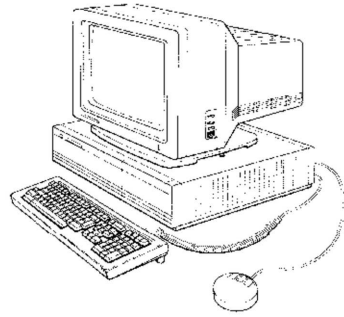

Getting Started

This chapter tells you

- How to prepare your site so your workstation can operate efficiently and safely
- How to make sure your shipment contains everything you need and what to do if something is missing or broken

Review Site Requirements

For your DECstation 2100/3100 workstation to work efficiently, your work environment must meet the requirements listed here.

Caution: *Failure to meet these requirements can cause damage to equipment.*

Temperature

- Keep the temperature around the workstation between 50° and 104° Fahrenheit (10° and 40° Celsius).
 - Set up your workstation away from heaters, photocopiers, and other sources of heat.
 - Protect your workstation from sunlight.

- Allow air to flow freely around your workstation to keep heat from building up and damaging your equipment.
 - Leave 4 inches (10 cm) of space between system unit vents and other objects.
 - Leave 3 inches (8 cm) of space between monitor vents and other objects.

Humidity

- Keep relative humidity within the range of 10 to 95 percent, unless you have an RZ55 disk drive, in which case the range should be 8 to 95 percent.

Cleanliness

- Keep your work area as dust-free as possible.

Power

- Set up your workstation at least 30 inches (90 cm) from other terminals or monitors or other sources of electrical interference.
- Limit exposure to static electricity by setting up your workstation away from busy corridors and other high-traffic areas.
- Provide a 6.5-ampere branch circuit for the exclusive use of your workstation.
- Be sure your electrical circuit is properly grounded and free from electrical noise.

Supplies

- Store supplies, such as tape cartridges, at the same temperature and humidity levels as your workstation.

Unpack and Check Your Equipment

As you unpack your shipment, check its contents against the packing list. Save the packing materials in case you ever need to store or ship your workstation.

Warning: *It takes two people to unpack the system unit and monitor safely.*

Your shipment should include all the items that appear in Figure 1-1, plus your software and any options you have ordered.

Note: *You do not need to use the power cord that comes with your monitor. In the DECstation 2100/3100 workstation, the monitor receives its power through the system unit, not from a wall outlet. To provide power to the monitor, you use the power cable that comes with your system unit.*

Inform the delivery agent and your Digital sales representative if any items are missing or damaged.

For a detailed list of items, with part numbers, available for your workstation, see Appendix B.

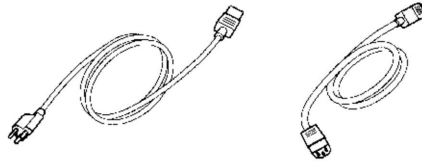
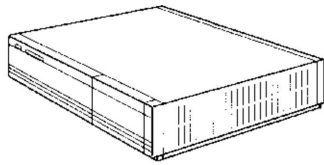

System unit, system power cord, and monitor-system unit power cable

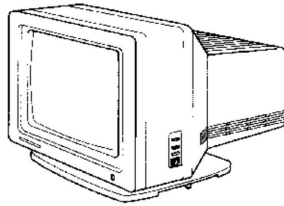

Monitor

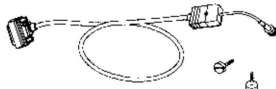

Video cable for monochrome monitor



Video cable for color monitor



Keyboard with cable



One ThinWire T-connector and two terminators

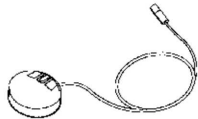

Mouse with cable



ThickWire loopback connector

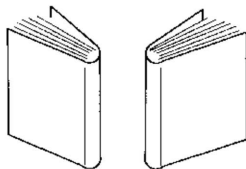

Documentation

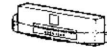

Small computer system interface (SCSI) terminator (may already be installed)

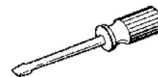

Screwdriver

DEPI002

Figure 1-1. The basic DECstation 2100/3100 shipment

2

Installing the Basic DECstation 2100/3100 Hardware

This chapter tells you how to install the basic DECstation 2100/3100 hardware.

Warning: *Plugging in power cords or turning on power before you are instructed to do so can cause injury and damage equipment.*

Set Up the System Unit

Caution: *Placing the system unit on its side blocks air vents and causes the unit to overheat.*

Place the system unit on a flat surface as near as possible to where you will use it.

- Leave enough space so you can connect the cables to the back of the unit.
- Be sure the on/off switch on the back of the system unit is set to the off (0) position.

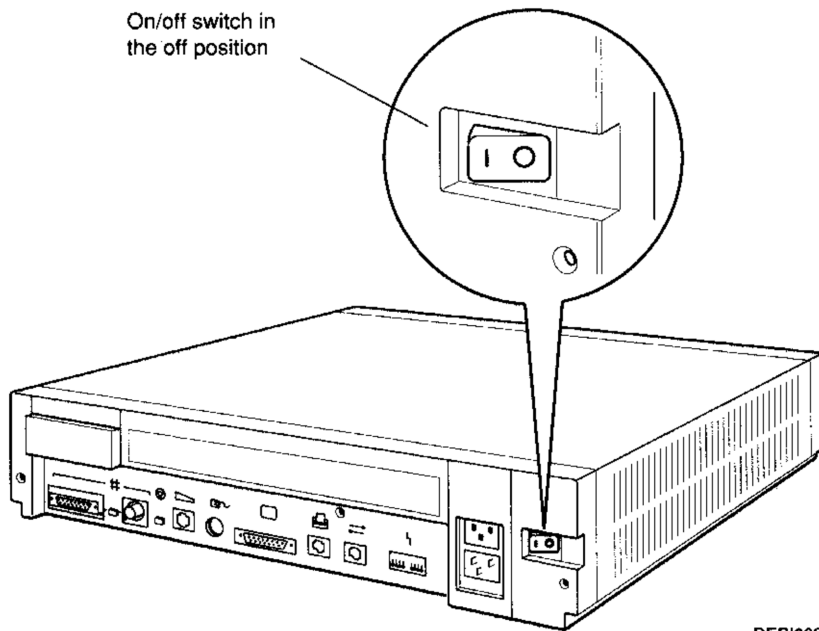

DEPI003

Figure 2-1. The on/off switch on the system unit

Connect the Keyboard to the System Unit

1. Position the keyboard cable connector so the clip is on the bottom.
2. Push the keyboard connector into the connector below the keyboard icon on the back of the system unit until it snaps into place.

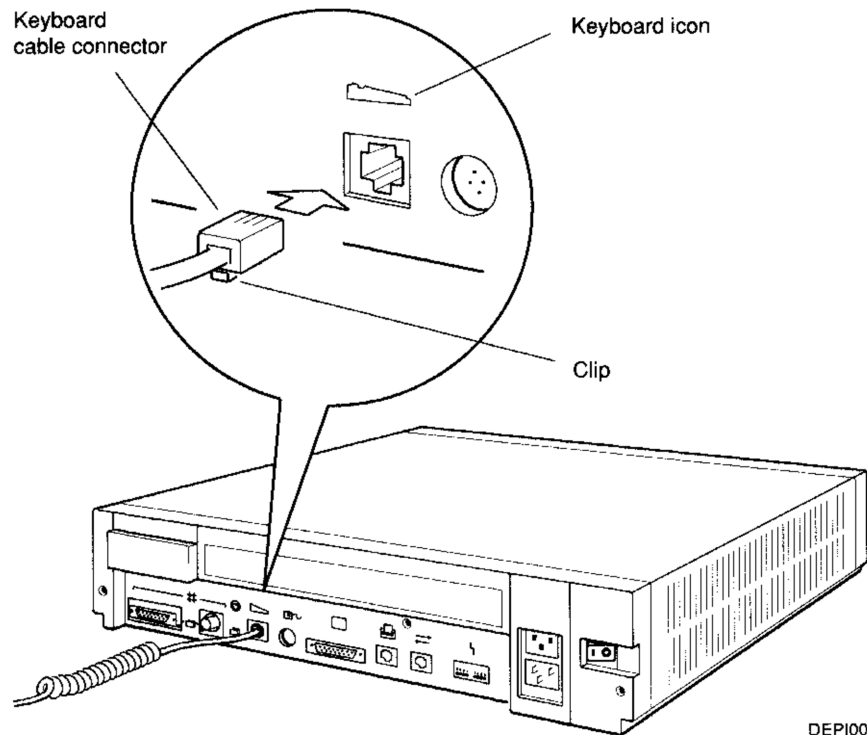

DEPI009

Figure 2-2. Connecting a keyboard to the system unit

Connect the Mouse to the System Unit

1. Carefully align the icon on the top of the mouse cable connector with the mouse icon on the back of the system unit.
2. Push the cable connector all the way into the connector on the back of the system unit.

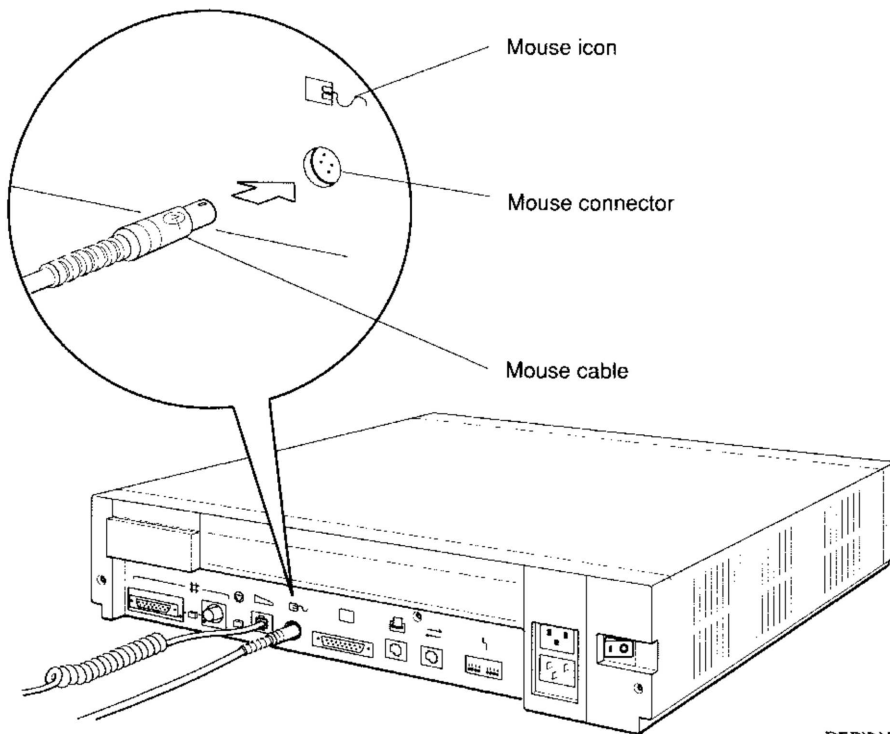

Figure 2-3. Connecting a mouse to the system unit

Connect the Ethernet Loopback Connector and Terminators

A ThickWire loopback connector and a ThinWire T-connector and two ThinWire Ethernet terminators came with your shipment.

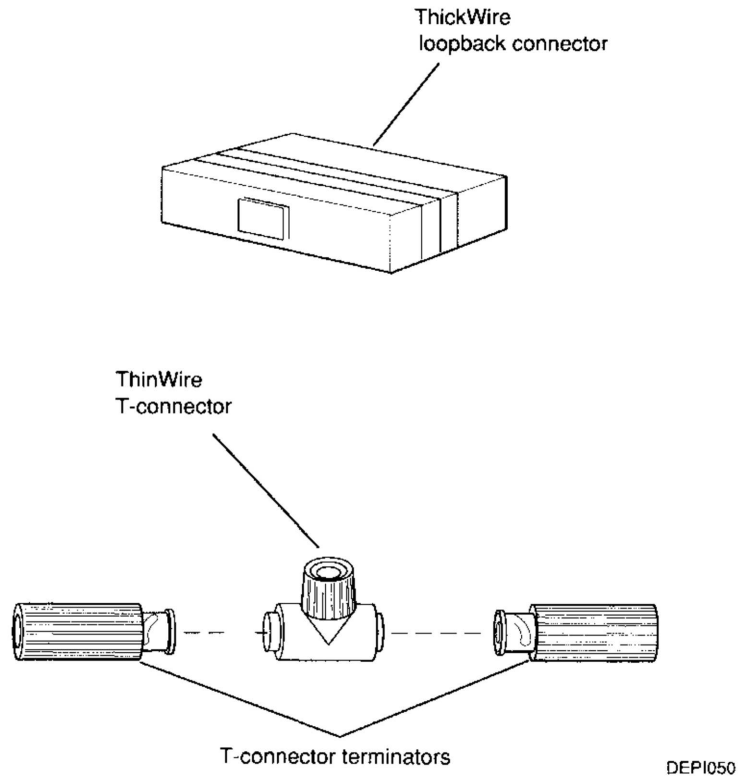
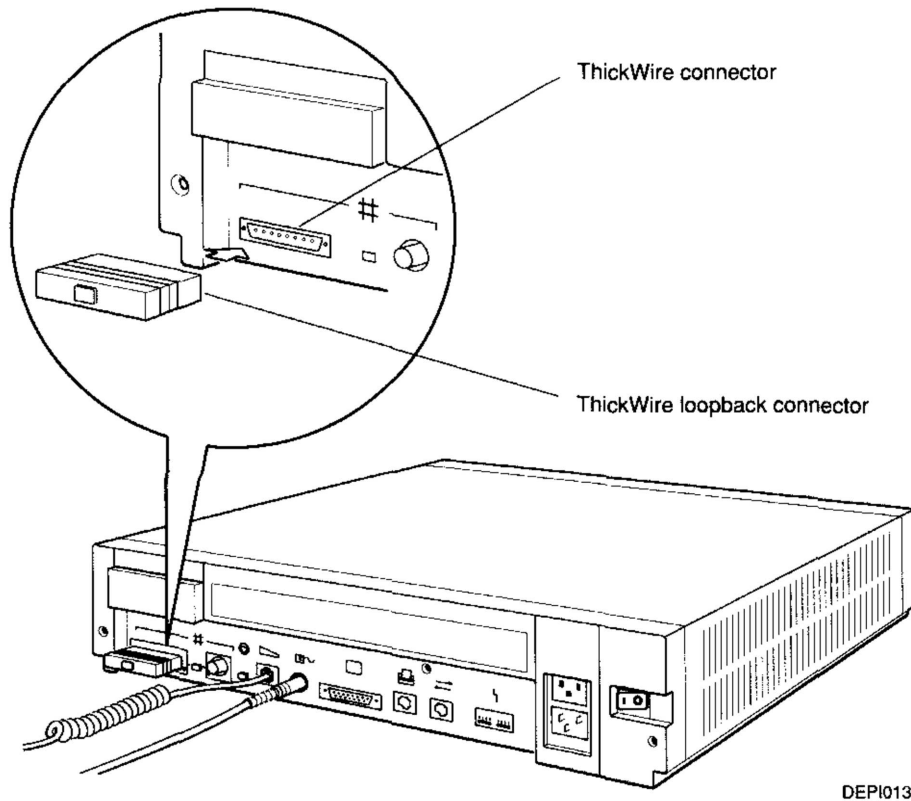

Figure 2-4. Ethernet loopback connector and terminators

To Install the ThickWire Ethernet Loopback Connector

1. Find the square ThickWire loopback connector that came with your shipment.
2. Position the loopback connector so its widest part aligns with the widest part of the ThickWire connector located in the lower-left corner of the back of the system unit.
3. Firmly press the loopback connector into the connector on the system unit.



DEPI013

Figure 2-5. Attaching a ThickWire loopback connector to the system unit

To Terminate ThinWire Ethernet

1. Find the T-connector and two terminators that came with your shipment.
2. Notice how the ribbed portion of the T-connector can be twisted from side to side.
3. Attach the terminators to the T-connector.
 - a. Firmly push each terminator connector onto the T-connector.
 - b. Twist the left-hand terminator toward you and the right-hand terminator away from you until they slide toward the T-connector and lock into place.

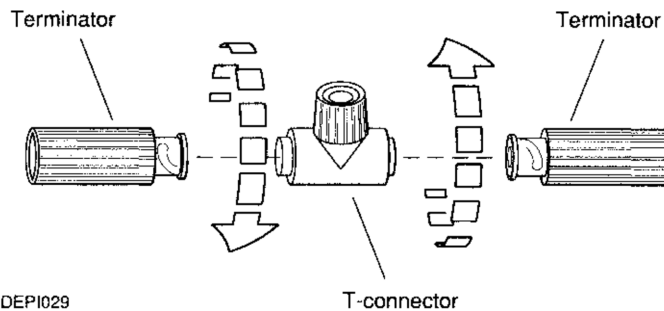
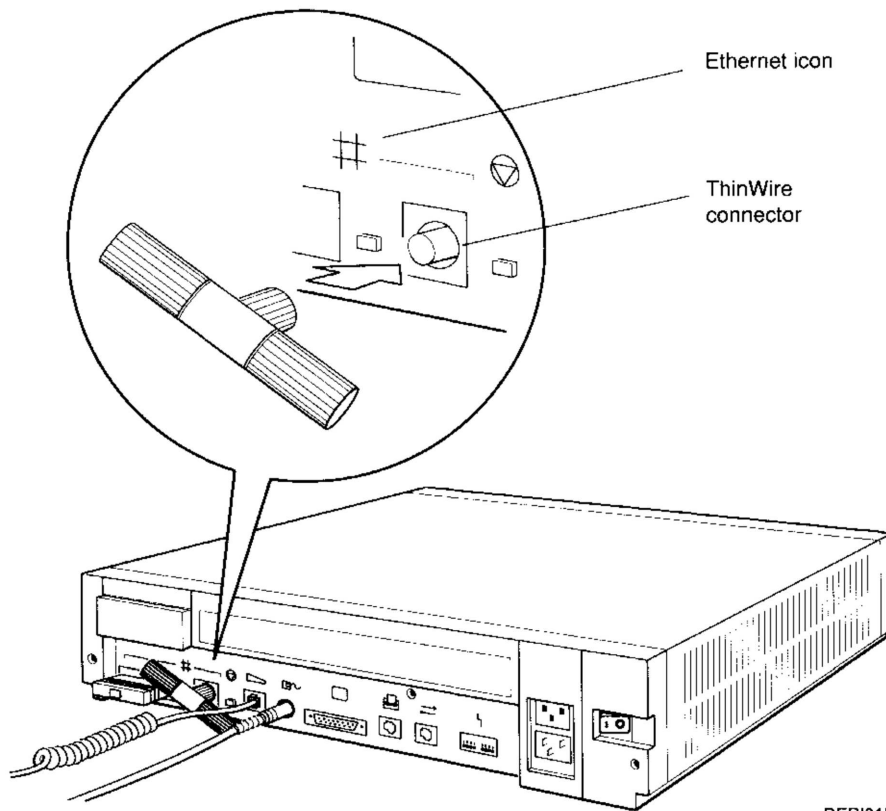

Figure 2-6. Attaching terminators to the T-connector

4. Push the ribbed portion of the terminated T-connector into the ThinWire Ethernet connector below the Ethernet icon on the back of the system unit.
- Note:* You have to tilt the terminated T-connector slightly to fit it between the ThickWire loopback connector and the keyboard cable.
5. Twist the T-connector from side to side until it slips into place and you can push it onto the connector on the system unit.
 6. Twist the ribbed portion of the connector to the right until it locks into place.



DEPI015

Figure 2-7. Attaching a terminated T-connector to the system unit

Terminate the SCSI Connector on the System Unit

1. Remove the plastic cover that protects the SCSI connector located in the upper-left corner of the back of the system unit.
 - a. Run your finger along the bottom of the cover until you feel the latch that lies between the two holes in the bottom of the cover.
 - b. Push up on the latch until it releases from the back cover of the system unit.

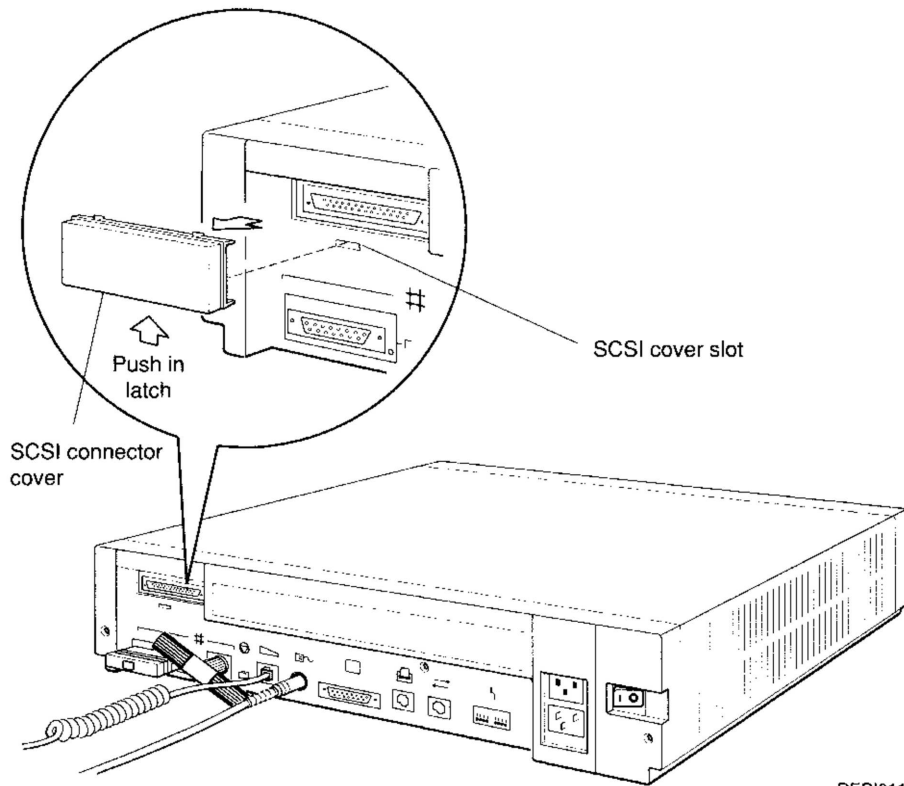

DEPI011

Figure 2-8. Removing the plastic cover that protects the SCSI connector

2. If the SCSI terminator is not already installed, install it by turning it so the widest part of its connector aligns with the widest part of the SCSI connector on the system unit.
3. Push the terminator into the SCSI connector.

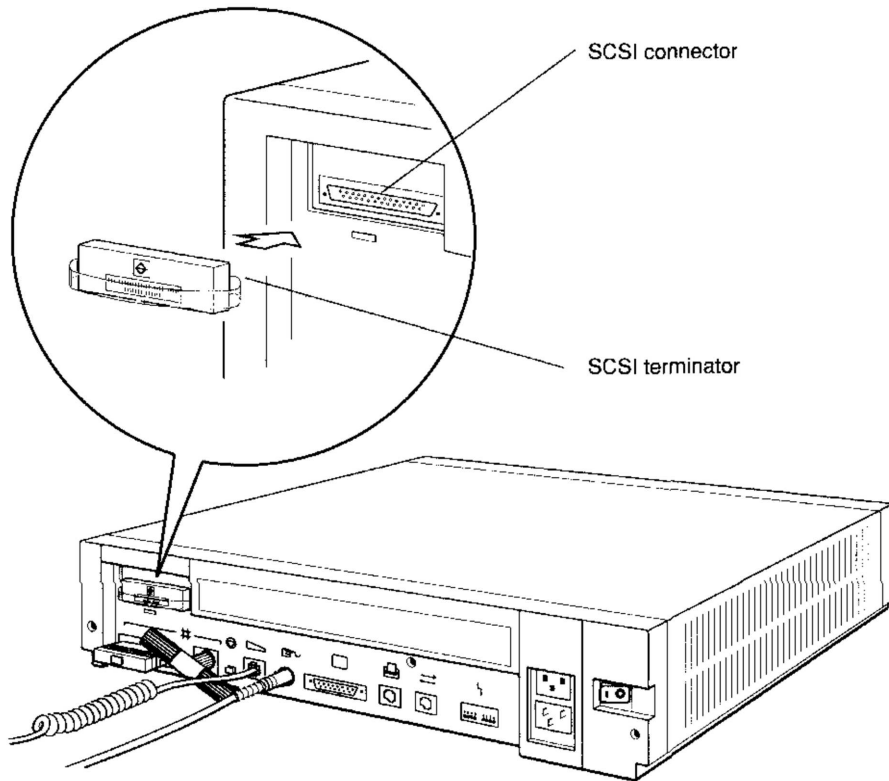

DEPI012

Figure 2-9. Installing a SCSI terminator

Connect the Video Cable to the System Unit

Your system unit comes with either a monochrome or a color video cable.

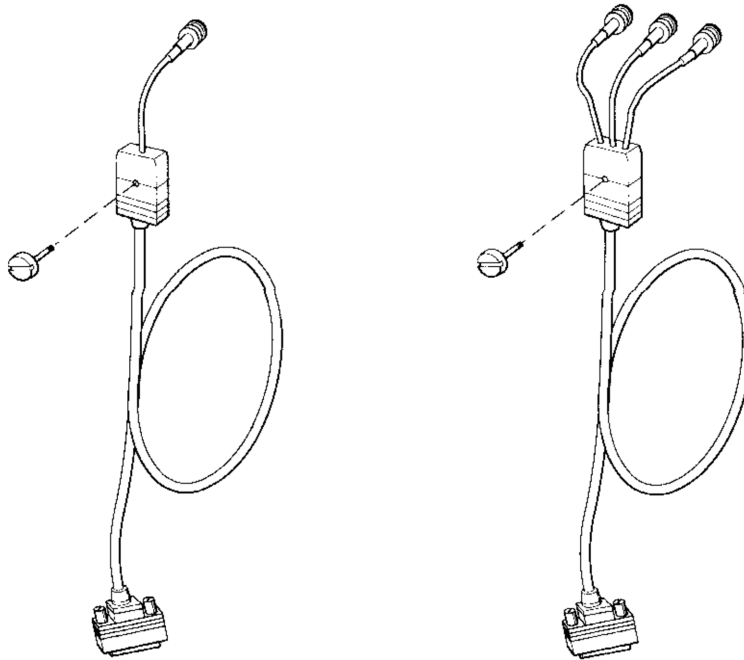

Monochrome cable

Color cable

DEPI005

Figure 2-10. Video cables

1. Find your video cable and the two knobs that came with it.
 - a. For both 15-inch monitors and for the 19-inch monochrome monitor, select the knob with the shortest screw.
 - b. For the 19-inch color monitor, select the knob with the longest screw.
2. Find the end of the video cable that has a square connector on it.

3. Position the cable connector so the longest side of the connector aligns with the widest part of the video connector on the system unit.
4. Push the cable connector into the connector on the system unit and turn both screws to the right until they are tight. If necessary, use the screwdriver that came with your system to tighten the screws.

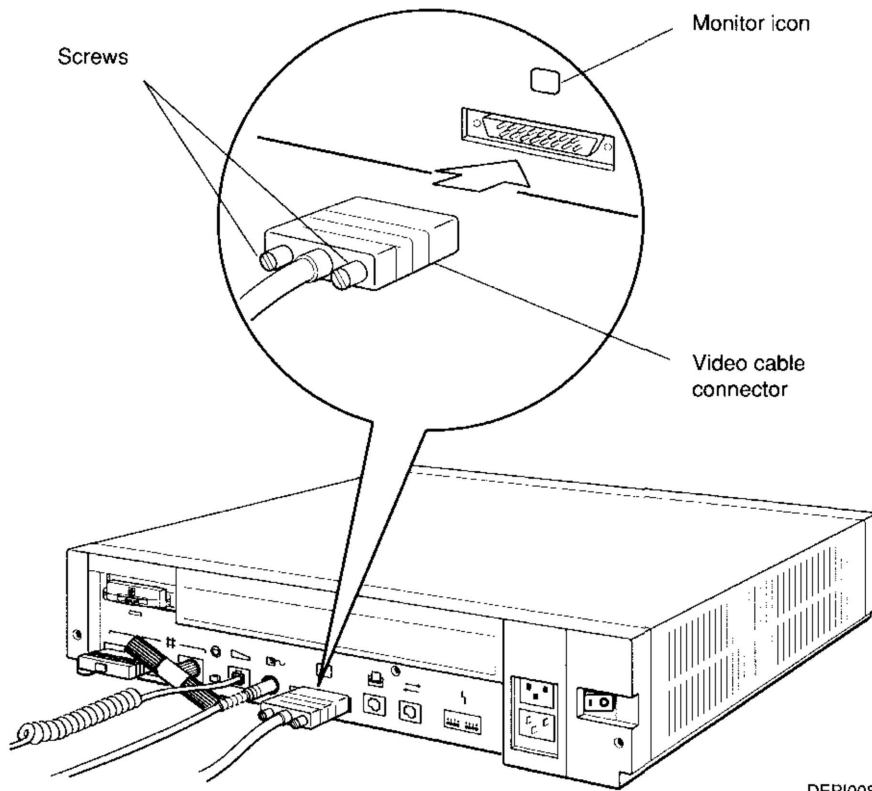
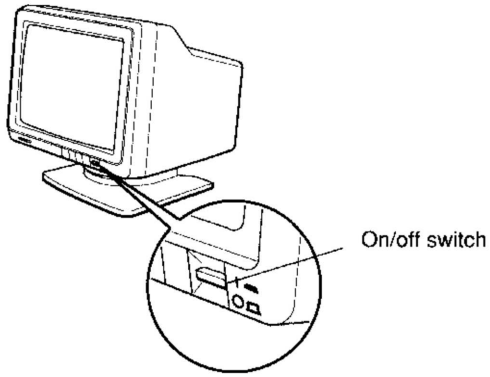

Figure 2-11. Connecting a video cable to the system unit

Set Up the Monitor

Warning: *It takes two people to lift the monitor safely.*

1. Place the monitor on top of, or next to, the system unit.
 - If you have a 19-inch color monitor, place it so the tilt-lock lever is on the right side of the monitor as you face the screen.
 - If you have a 19-inch monochrome monitor and you have ordered the optional tilt-swivel stand, set the monitor on it according to the instructions that came with the stand.
 - Both 15-inch monitors come with built-in tilt-swivel stands that do not lock into place and have no visible controls.
2. Be sure the on/off switch on the monitor is set to the off (0) position, as shown in Figure 2-12.



15-inch monochrome monitor

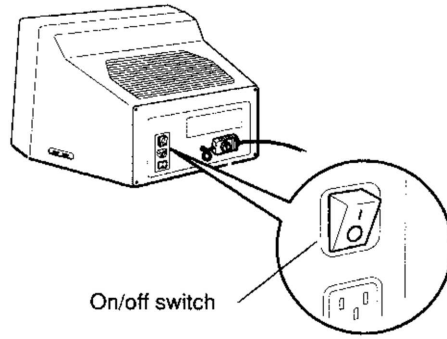

19-inch monochrome monitor

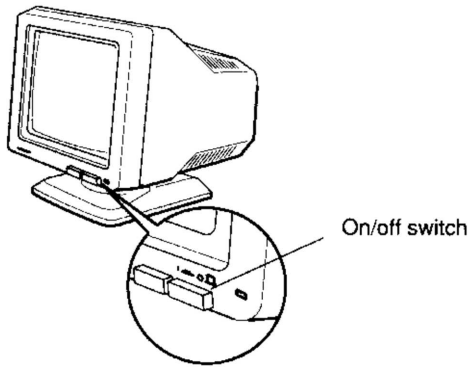

15-inch color monitor

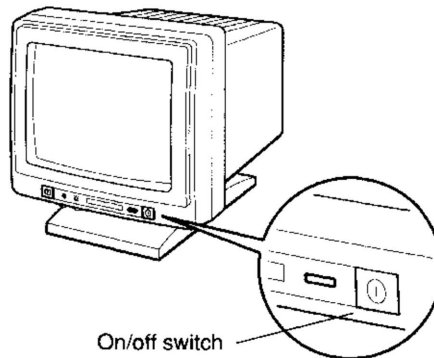

19-inch color monitor

DEPI004

Figure 2-12. The on/off switch on the monitor

Connect the Video Cable to the Monitor

The video cable for a monochrome monitor has one round connector on its free end. The video cable for a color monitor has three round connectors on its free end.

- To connect a video cable to a monochrome monitor, turn to page 2-16.
- To connect a video cable to a color monitor, turn to page 2-18.

To Connect a Video Cable to a Monochrome Monitor

1. Firmly push the round connector on the free end of the video cable onto its connector on the monitor and twist it to the right until it slides forward and locks into place.

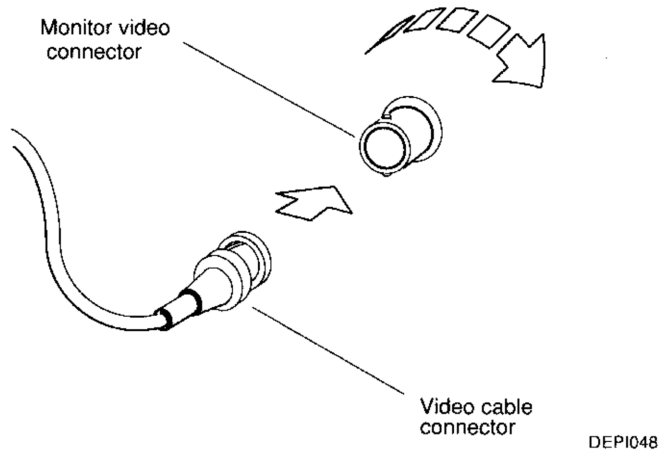

Figure 2-13. Connecting a video cable connector

2. Place the cable's connector block on the cable mounting plate or against the mounting detail on the monitor, as shown in Figure 2-14.
3. Find the knob with the short screw on it.
4. Insert the screw on the knob into the hole on the connector block and turn the knob to the right to tighten it.

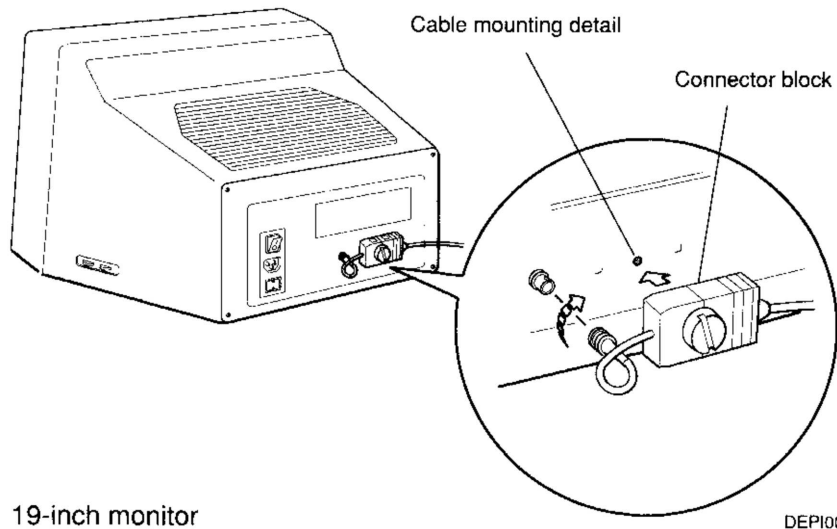
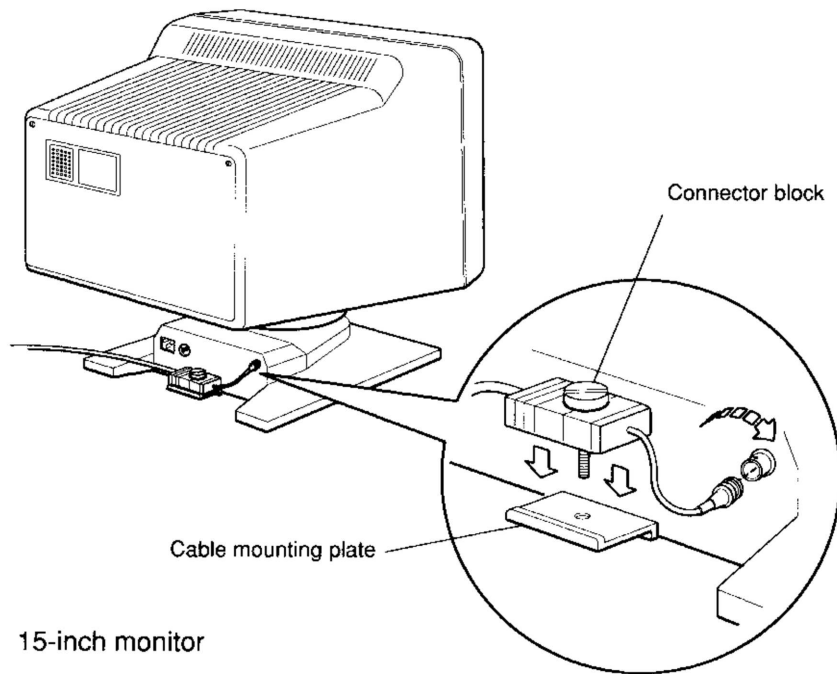

Figure 2-14. Connecting a video cable to a monochrome monitor

To Connect a Video Cable to a Color Monitor

The free end of the video cable has a set of red, green, and blue (RGB) signal cables. These three cables connect with the three connectors on the back of the monitor in the following order, from left to right: red, green, blue.

1. Firmly push each cable connector onto its connector on the monitor and twist it to the right until it slides forward and locks into place.

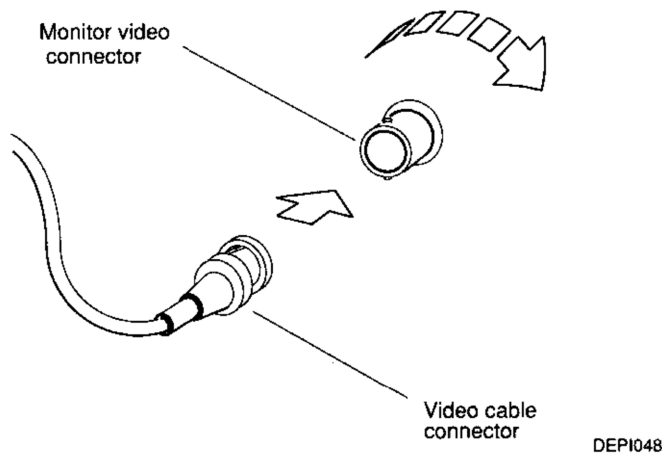

Figure 2-15. Connecting a video cable connector

2. Place the cable's connector block on the cable mounting plate or against the cable mounting detail on the monitor, as shown in Figure 2-16.
3. Insert the screw on the knob into the hole on the connector block and turn the knob to the right to tighten it.
 - For the 15-inch color monitor, use the knob with the short screw.
 - For the 19-inch color monitor, use the knob with the long screw.

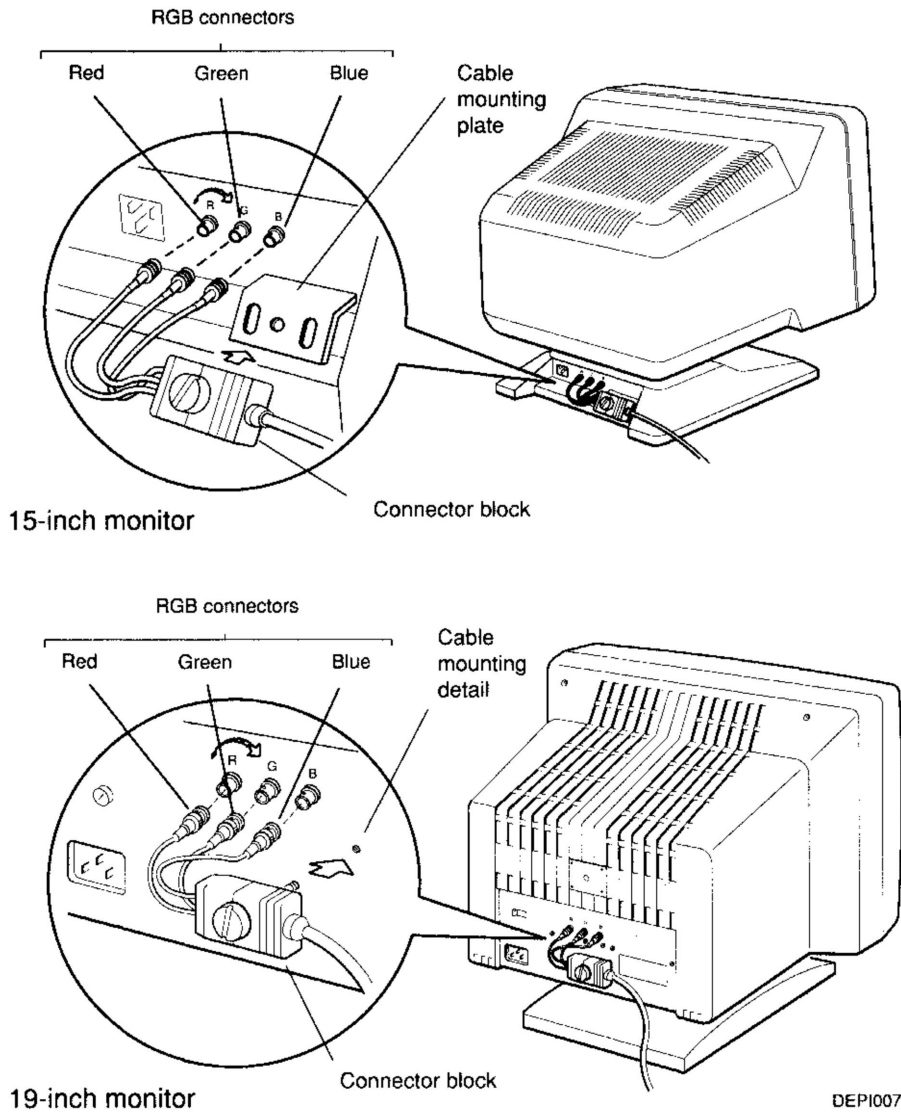

Figure 2-16. Connecting a video cable to a color monitor

Connect the Power Cable and Power Cord

With your shipment, you received a monitor–system unit power cable that allows power to flow from the power source through the system unit and to the monitor. You use this cable instead of the power cord that came in your monitor carton.

Power cords for optional devices come with those devices. After you have connected the system unit power cord and the power cable, set up your optional devices and connect their power cords according to the instructions that came with them.

The voltage for many devices, including most monitors, must match that of your power source. It is either 110/120 or 220/240 volts. Where necessary, a yellow voltage label that covers the power connector tells you what you have.

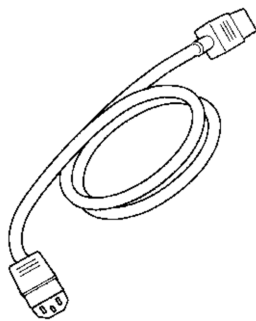

Monitor-system unit power cable

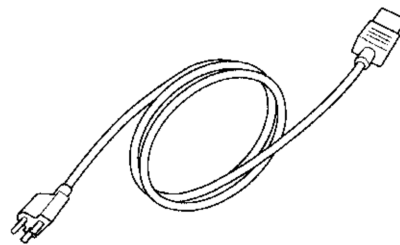

System unit power cord

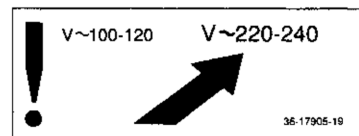
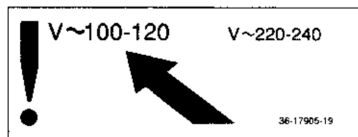

Voltage labels

DEPI016

Figure 2-17. Power cable, power cord, and voltage labels

To Connect the Monitor-System Unit Power Cable

Caution: Connecting the monitor to a system unit that receives its power from a source that does not meet the voltage requirements of the monitor can damage the monitor.

1. Read and remove any yellow voltage label that covers the power connector on the back of the monitor.
2. Plug the prongless end of the power cable into the power connector on the monitor.
3. Plug the pronged end of the cable into the power outlet on the back of the system unit.

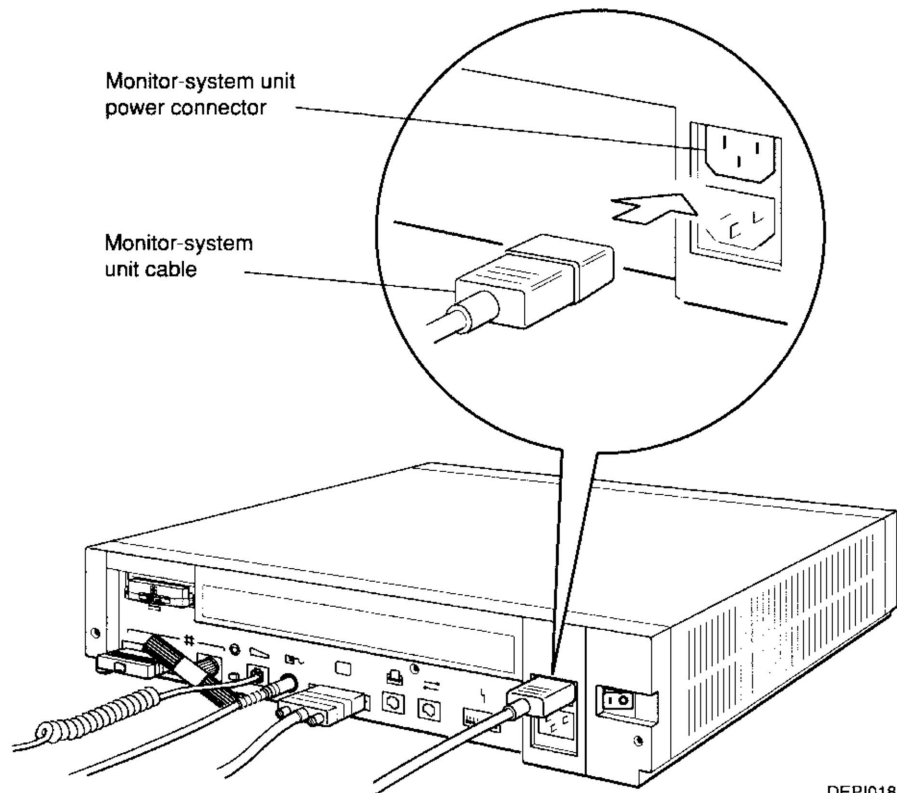

DEPI018

Figure 2-18. Connecting a power cable to a system unit power outlet

To Connect the System Unit Power Cord

1. Plug the prongless end of the power cord into the power connector on the back of the system unit.
2. Plug the pronged end of the cord into the power source.

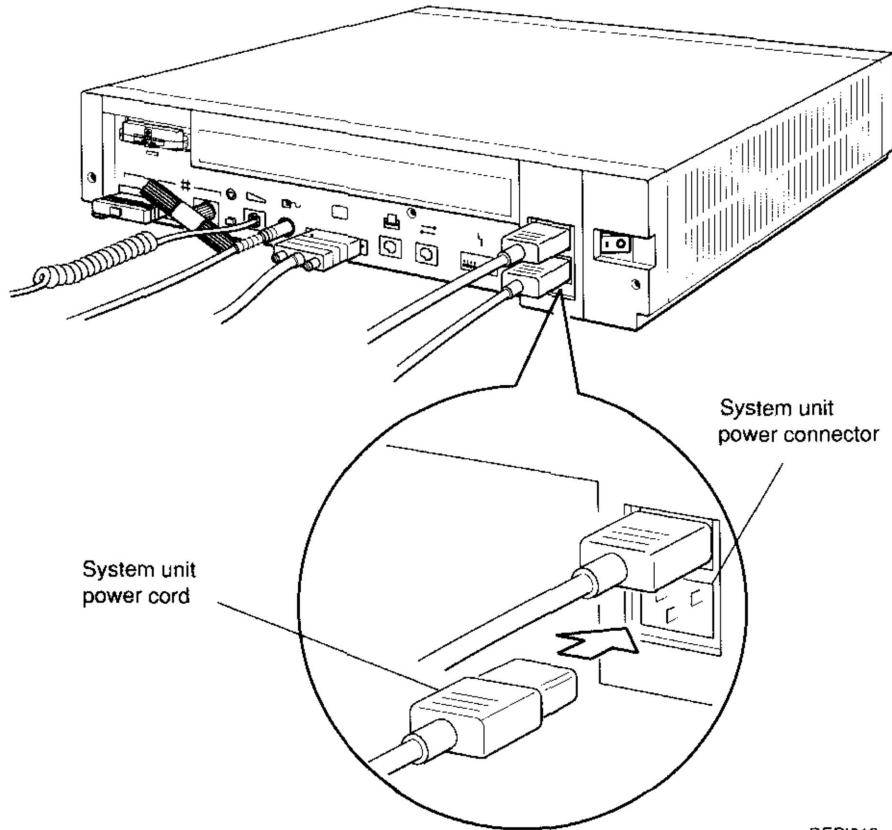

Figure 2-19. Connecting the system unit power cord

DEPI019

Starting and Testing the Workstation

This chapter tells you

- How to turn on your monitor and system unit
- How the power-up self-test operates and how to use the results
- How to get your workstation connected to a network

Turn On the Monitor

The procedure for turning on the monitor varies according to the monitor. In all cases, a green light glows on the front of the monitor and a display appears on the screen after you turn on the system unit.

1. Find the brightness and contrast controls located by their icons on the monitor.
2. Turn both controls all the way on.



Contrast icon

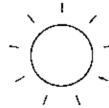

Brightness icon

DEPI052

Figure 3-1. Contrast and brightness icons

To Turn On a 15-Inch Monochrome Monitor

Set the on/off switch on the front of the monitor to the on (in) position by pressing it until it locks into place.

The indicator light glows green and the display appears after you turn on your system unit.

To Turn On a 19-Inch Monochrome Monitor

Set the on/off switch on the back of the monitor to the on (1) position by pressing the 1 on the switch.

The indicator light glows green and the display appears after you turn on your system unit.

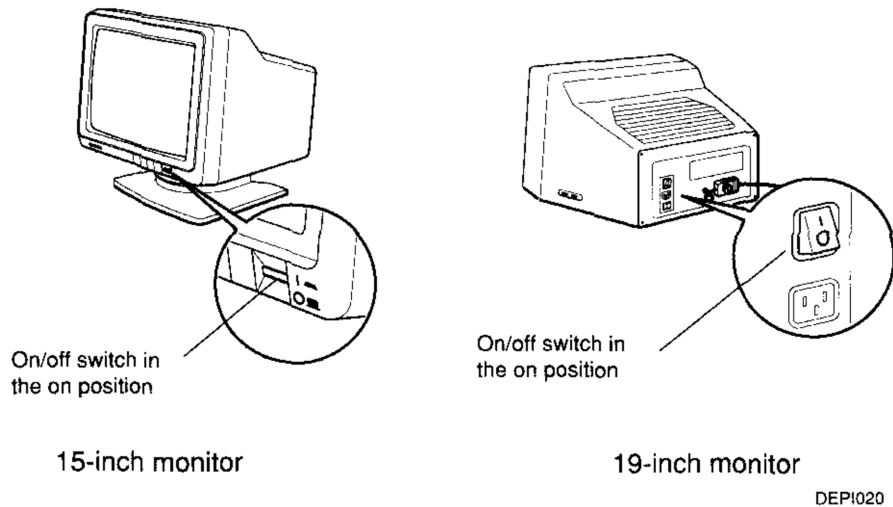

Figure 3-2. Turning on monochrome monitors

To Turn On a 15-Inch Color Monitor

Set the on/off switch on the front of the monitor to the on (in) position by pressing it until it locks into place.

The indicator light glows green and the display appears after you turn on your system unit.

To Turn On a 19-Inch Color Monitor

Set the on/off switch on the side of the monitor to the on (1) position by pressing the 1 on the switch.

The indicator light glows green and the display appears after you turn on your system unit.

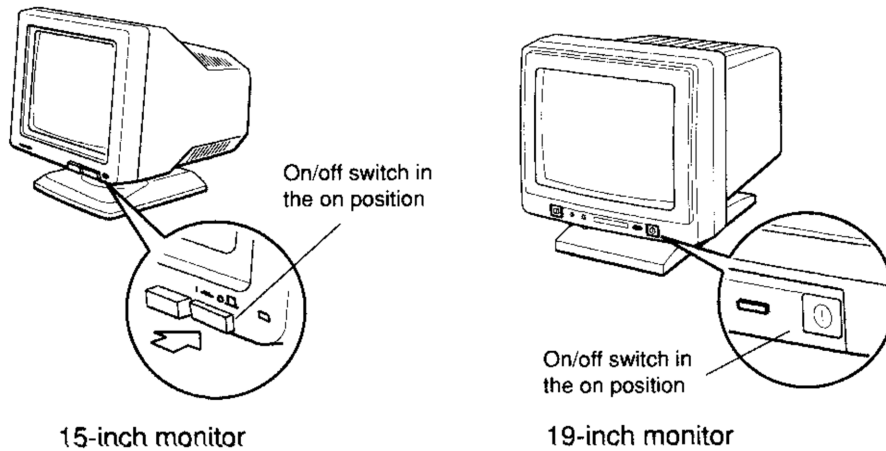

DEPI021

Figure 3-3. Turning on color monitors

Turn On the System Unit

Caution: To avoid damaging equipment that has been moved inside from a cold environment, let it warm to room temperature before turning it on.

Set the on/off switch on the back of the system unit to the on (1) position by pressing the 1 on the switch.

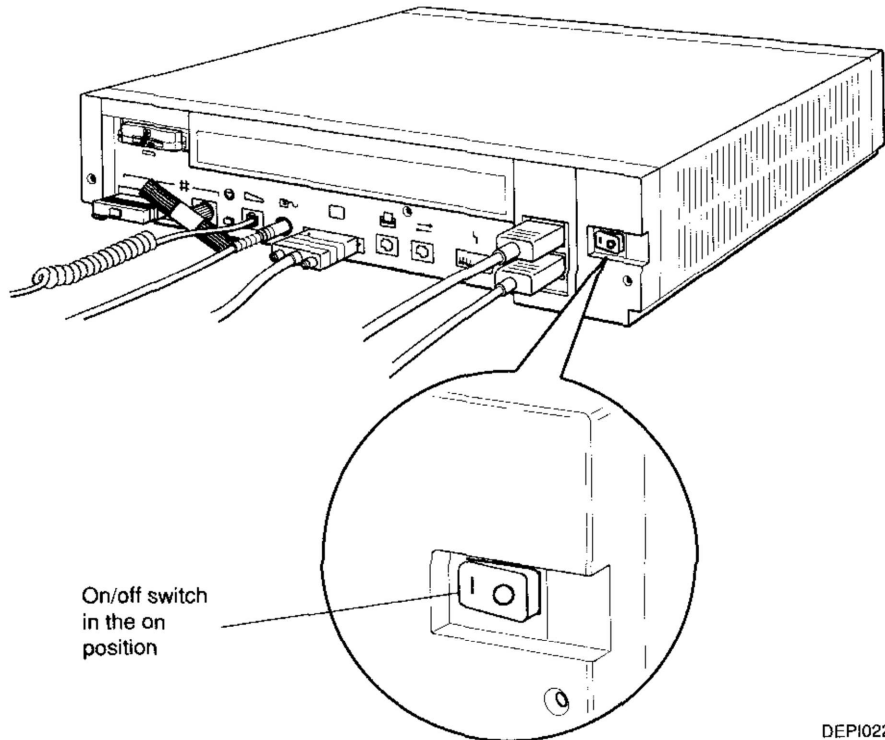

DEPI022

Figure 3-4. Turning on the system unit

When the system unit turns on, the following things happen:

- The system unit begins its power-up self-test.
- The power indicator light on the front of the system unit glows green.
- The power-up self-test messages gradually appear at the bottom of the monitor screen.
 1. Turn down the brightness until the screen just becomes dark.
 2. Adjust the contrast until the display on the screen is comfortable for you to read.

If Your System Fails to Turn On

If nothing happens when you turn on the system unit, check to be sure that

- All power cords are connected properly
- There is power at the power outlet
- Monitor and system unit power switches are set to the on position

If the system still fails to work, contact your system manager or your Digital service representative.

If Your Monitor Fails to Turn On

If the green light on the monitor turns on but the screen stays dark, be sure the contrast and brightness controls located by their icons on the monitor are turned all the way on.

If the screen remains dark, contact your system manager or your Digital service representative.

Check the Results of the Power-Up Self-Test

After you turn on your system unit and monitor, your workstation tests itself. This process takes about a minute. The numbers that identify the subtests that make up the self-test appear on your screen as your workstation runs them.

Because some subtests take longer than others, there are times when nothing happens on your screen. For example, the following display remains on your screen for several seconds:

```
KN01 V6.71
7..6..5..4..
```

During testing, a display similar to the following gradually appears on your screen:

```
KN01 V6.71
7..6..5..4..3..2..1..0
16Mb.....0
```

When testing has been completed successfully, a display similar to the following appears at the bottom of the screen:

```
KN01 V6.71
08-00-2b-0d-f7-6a
0x01000000
>>
```

If a Subtest Is Unsuccessful

If your workstation fails a subtest, self-testing stops and the following message flashes on the screen:

```
FAILURE - RESET TO CONTINUE
```

The number of the subtest that failed is the last number displayed on your screen. In the following example, subtest 4 was unsuccessful.

```
KN01 V6.71
7..6..5..4..
FAILURE - RESET TO CONTINUE
```

If subtest 7, 6, 5, or 4 fails

Record the number of the failed subtest and report it to your system manager or your Digital service representative.

If test 3 fails

1. Turn off the system unit and check the connections for your keyboard and mouse.

Be sure to inspect the connectors on the system unit and the cable connectors for damaged pins.

2. Turn on the system unit to rerun the self-test.

If the subtest fails again, contact your system manager or your Digital service representative.

If subtest 2 fails

1. Turn off the system unit and be sure your ThickWire loopback connector and ThinWire Ethernet terminators are connected properly.

Inspect the ThickWire loopback connector and the ThickWire connector on the system unit for damaged pins.

2. Turn on the system unit to rerun the self-test.

If the subtest fails again, contact your system manager or your Digital service representative.

If subtest 1 fails

1. Turn off the system unit and be sure your SCSI terminator is securely connected.

Inspect the SCSI connector on the system unit and the connector on the terminator for damaged pins.

2. Turn on the system unit to rerun the self-test.

If the subtest fails again, contact your system manager or your Digital service representative.

Arrange for Your Ethernet Connection

If your workstation will be connected to a network, you need to find your Ethernet station address and report it to your system manager. Then ask your system manager to connect you to the network.

To Find Your Ethernet Station Address

Type **test -c** at the console prompt. A display similar to the following should appear on the screen. The third line of the display is your Ethernet station address.

```
MEM: 16Mbytes
VIDEO: MONO
ETHERNET STA ADDR: 08-00-2b-0d-f7-6a
SCSI DEVS:
U[7]
U[6]KN01--SII
U[5]
U[4]
U[3] Dev typ 0 RZ
      RMB                0x0
      Vrs                 1
      Format              1 CCS
      Add len            31
      Vndr               DEC
      PID                RZ23      (C) DEC
      Frevlvl           0618
U[2]
U[1]
U[0]
>>
```

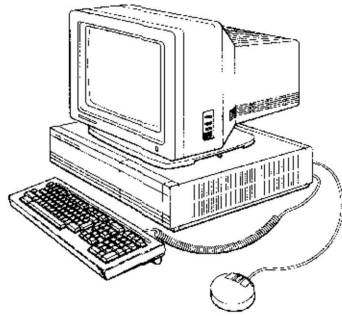

Installing Optional Peripheral Devices

This chapter tells you how to install the optional peripheral devices for your workstation.

External optional devices include up to four small computer system interface (SCSI) storage devices, a printer, and a modem. SCSI storage devices include tape drives and hard disk drives.

Warning: *Turning on power before you are instructed to do so can cause injury and damage equipment.*

Installing External Storage Devices

The types of external storage devices available for your DECstation 2100/3100 workstation include the following:

- 332-megabyte RZ55 hard disk drive
- 95-megabyte TK50Z tape drive
- 635-megabyte RRD40 optical compact disc drive

These come preinstalled in expansion boxes.

Note: *The system unit and all external storage devices must receive power from a common power source. If you have more than one expansion box, use a power strip as your power source.*

Caution: *Using different power sources can damage your equipment.*

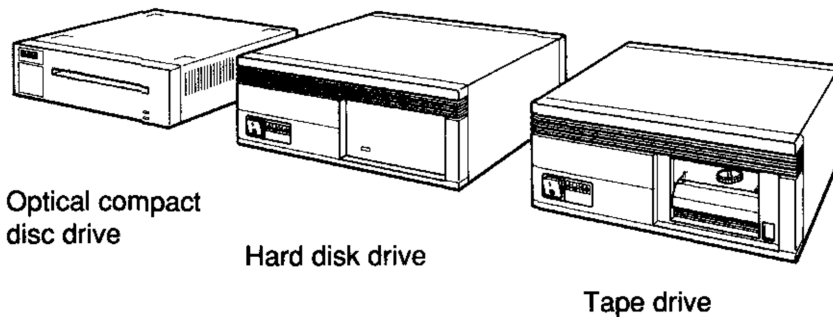

DEPI063

Figure 4-1. Expansion boxes

You can connect as many as four expansion boxes to your system.

The first box connects directly to the system unit. Each additional box connects to the box connected before it.

Connecting Expansion Boxes

Find the following items for each box you plan to install:

- One system unit-expansion box cable with a different connector at each end

You use this cable for only the first box you install. If you have more than one of these cables, set the others aside.

- One 18-inch-long expansion box cable with identical connectors at each end

Caution: *Using cables other than the Digital-supplied 18-inch cable between expansion boxes and the Digital-supplied system-unit expansion box connector cable can cause the boxes to malfunction.*

- One expansion box terminator

You need only one terminator. Set any others aside.

- One expansion box power cord

Other items may have been supplied and should be used where appropriate.

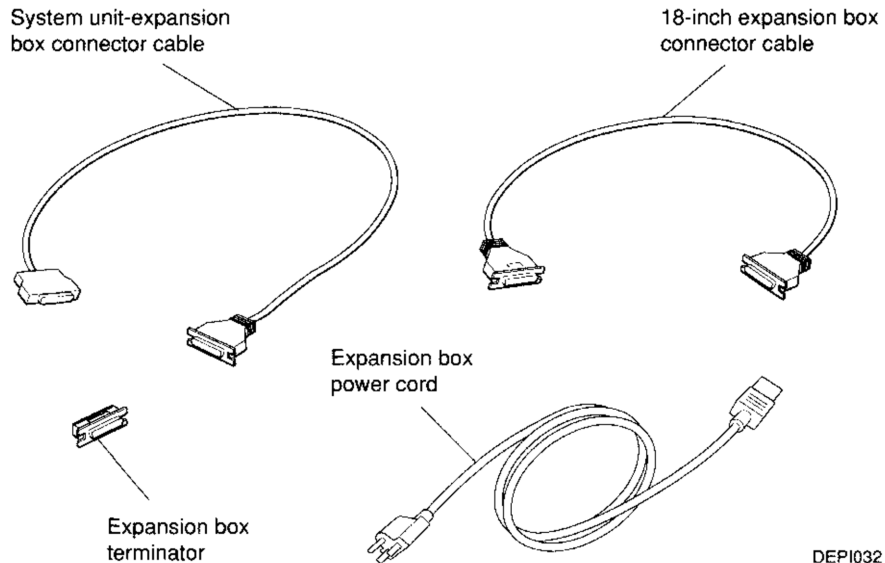

Figure 4-2. Expansion box cables, cord, and terminator

1. Turn off the system unit and any expansion boxes.
 - If you receive your power from a power strip, turn off the power strip.
 - If you have only one expansion box and do not use a power strip, turn off the expansion box by pressing the 0 on the on/off switch on the box. Then turn off the system unit.

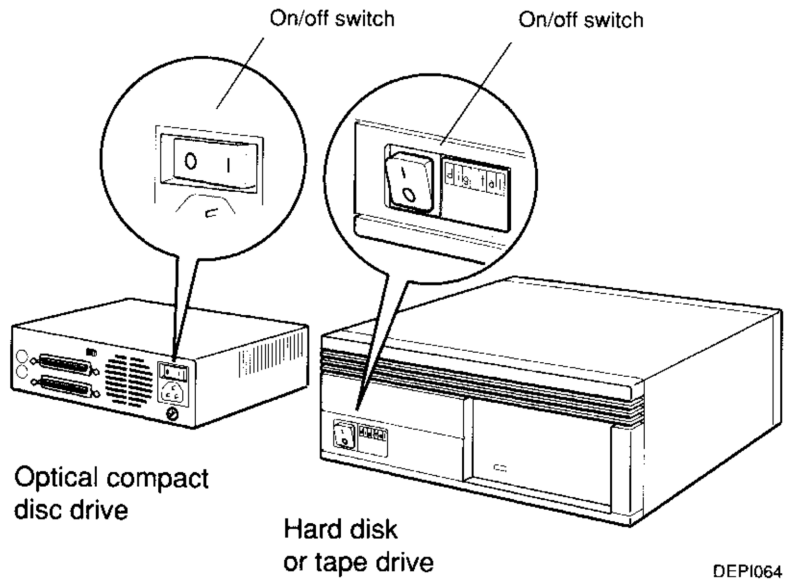
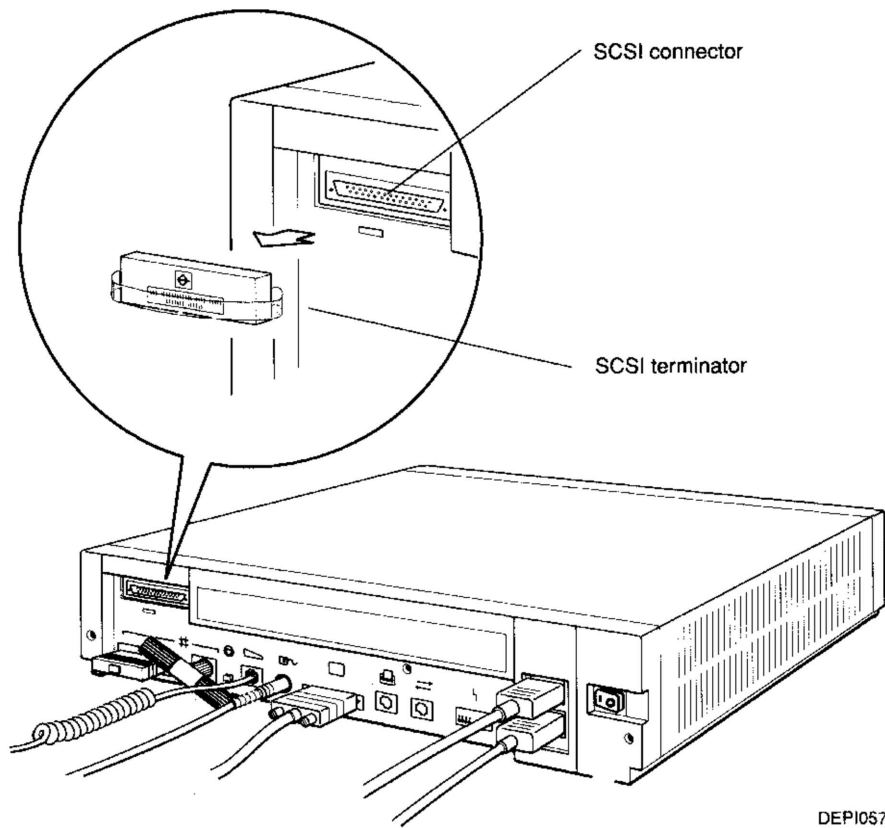

Figure 4-3. Expansion box on/off switch

2. Remove the terminator from the SCSI connector on the back of the system unit, as shown in Figure 4-4.
Be sure to save the terminator.



DEPI057

Figure 4-4. Removing the SCSI terminator

3. If you have only one box, or if this is the first box you are connecting, be sure the SCSI switches on the back of the box are set correctly.

- If your first box is a tape drive (you can see TK SCSI on the label by the switches), the settings are
Down Up Down

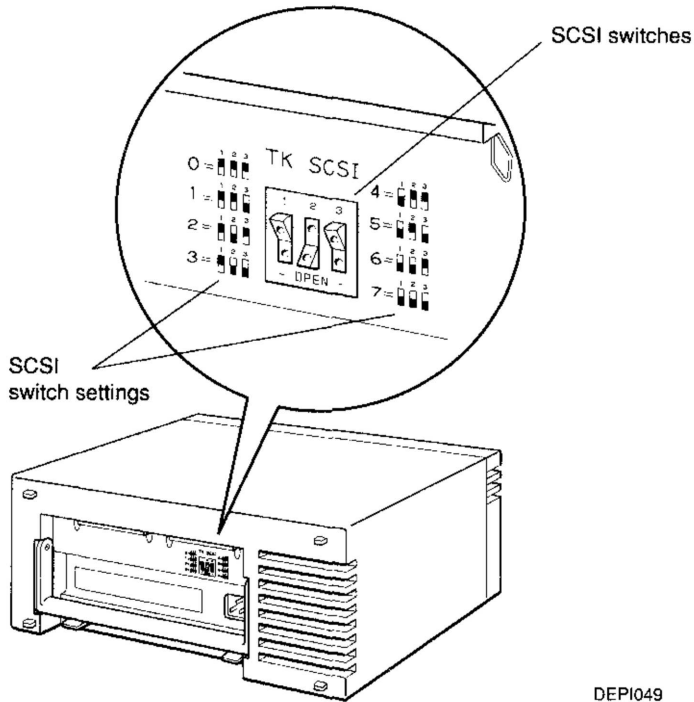

DEPI049

Figure 4-5. ID switch setting for the tape drive

- If your first box is a hard disk drive (you can see RZ SCSI on the label by the switches), the settings are
Down Down Down

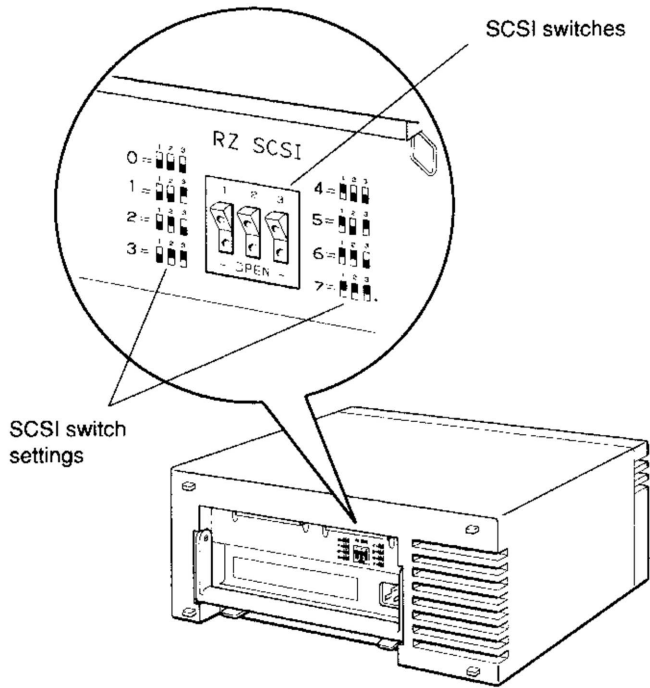

DEPI039

Figure 4-6. ID switch setting for the hard disk drive

- If your first box is an optical compact disc drive (there is no label by the switches), the settings are

Up Down Down Down

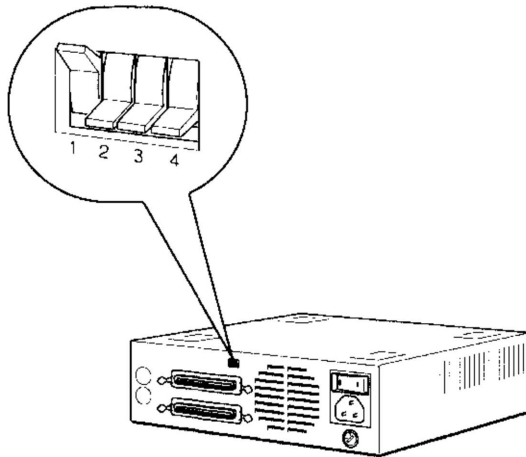

DEFM081

Figure 4-7. ID switch setting for the optical compact disc drive

4. Position the smallest of the two connectors on your system unit-expansion box cable so the widest part of the connector aligns with the widest part of the connector on the system unit.
5. Push the cable connector into the SCSI connector on the back of the system unit.

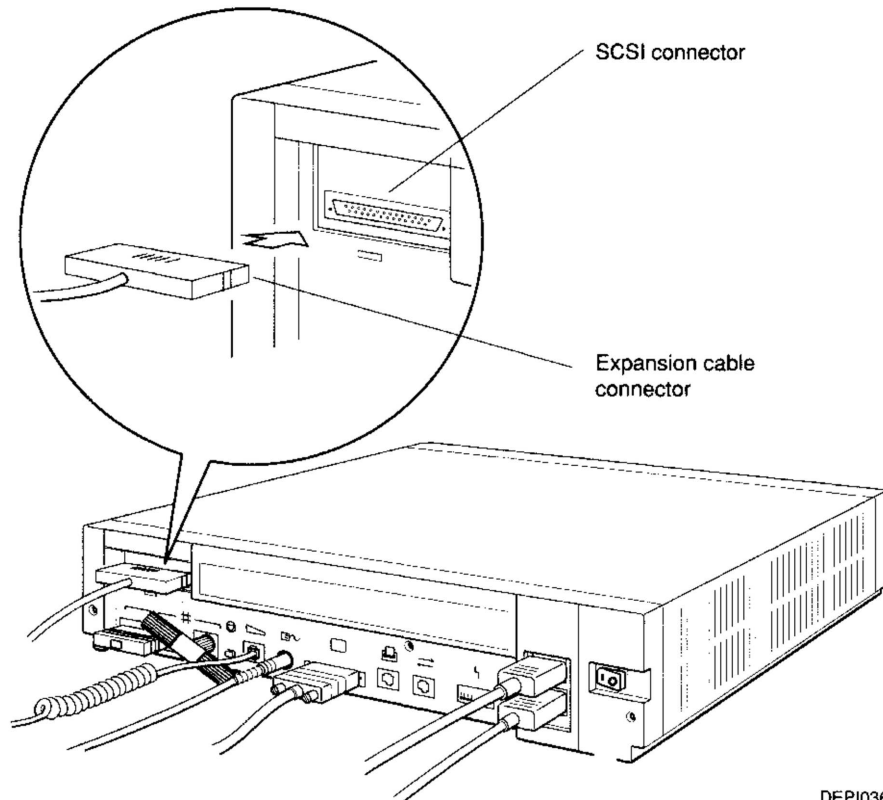

DEPI036

Figure 4-8. Attaching a system unit-expansion box cable to the SCSI connector on the system unit

6. Attach the free end of the system unit-expansion box cable to one of the connectors on the back of the expansion box.
 - a. Press the two wire brackets on the expansion box connector away from the connector.

If you are using a hard disk drive or a tape drive, slide the cable connector up between the expansion box and its handle.
 - b. Position the cable connector so its widest part aligns with the widest part of the expansion box connector.
 - c. Push the cable connector into the expansion box connector as far as it will go.

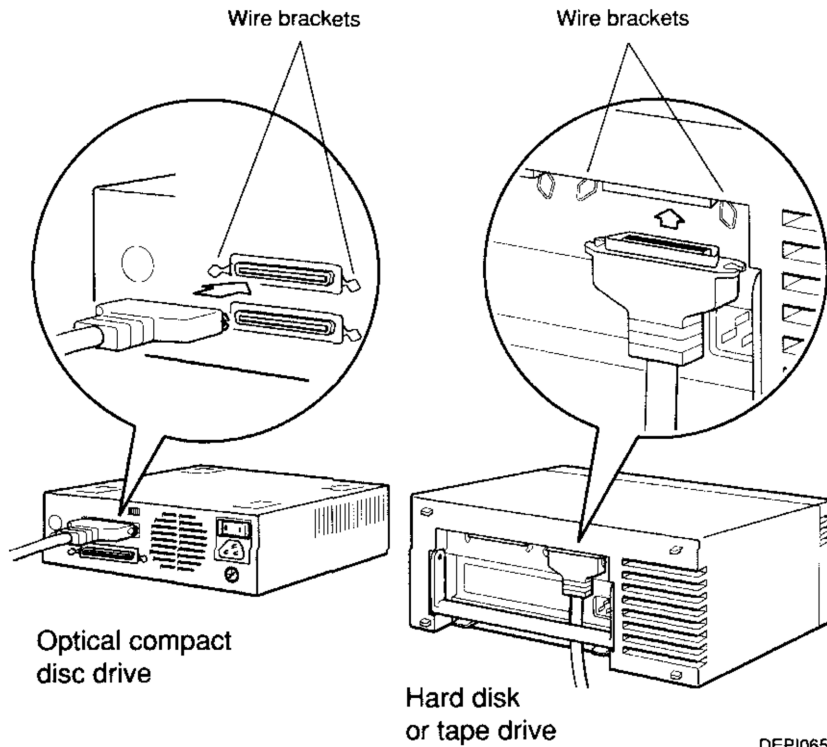
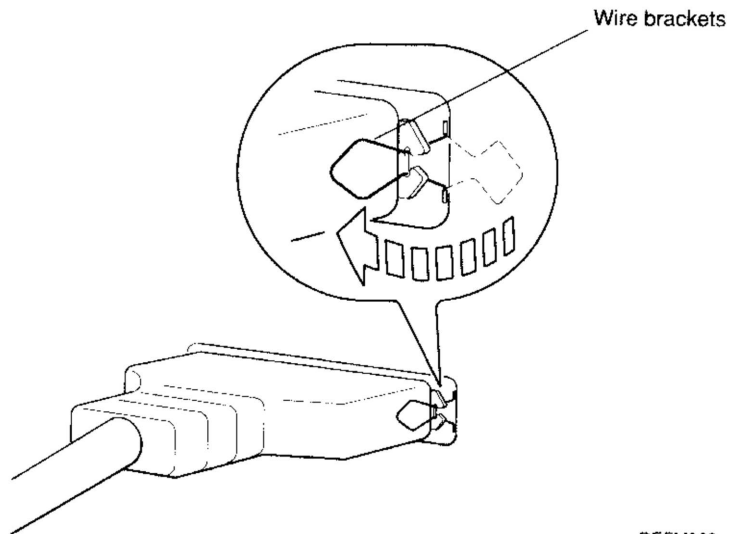

Figure 4-9. Attaching a system unit-expansion box cable to the SCSI connector on an expansion box

- d. Press the two wire brackets firmly against the sides of the connector until they click into the grooves on the connector.



DEFM068

Figure 4-10. Closing the wire brackets

If you are attaching more than one expansion box, turn to step 2 on page 4-13.

To attach only one box

1. Attach the terminator that came with your expansion box to the empty connector on the box.
 - a. Press the two wire brackets on the empty connector away from the connector.
 - b. Position the terminator so the widest part of its connector aligns with the widest part of the connector on the box.
 - c. Push the terminator into the expansion box connector as far as it will go.
 - d. Press the two wire brackets firmly against the sides of the terminator until they click into the grooves on the terminator.

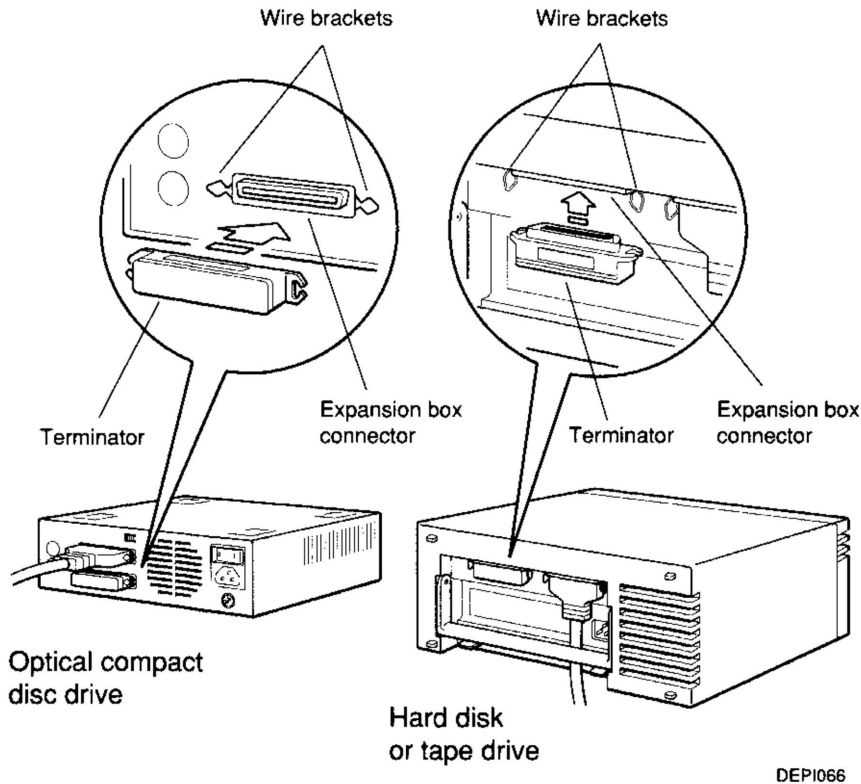
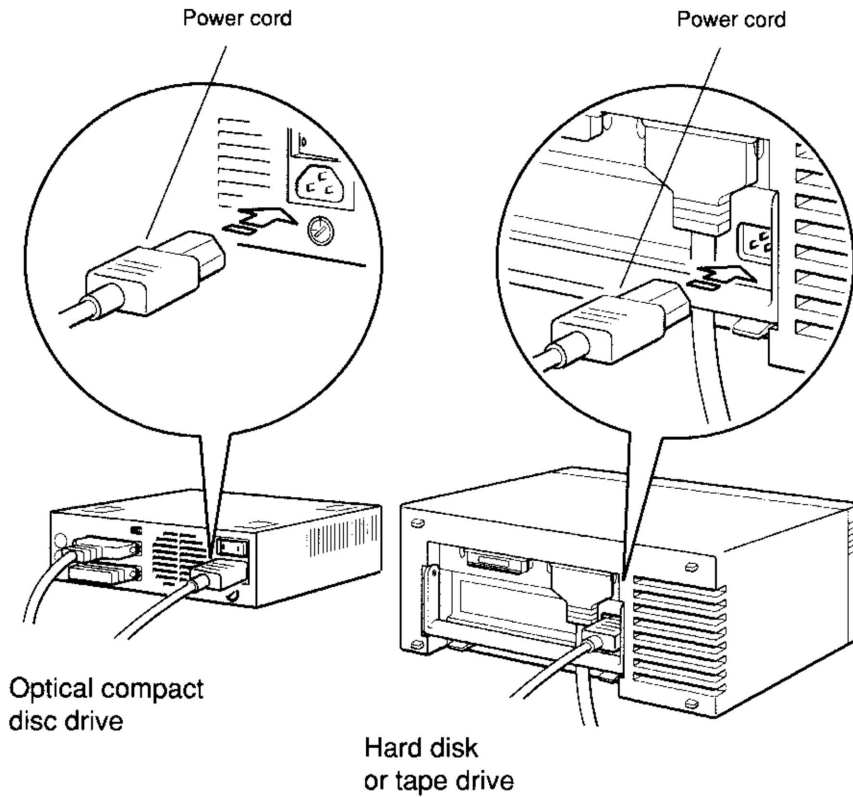

Figure 4-11. Terminating an expansion box

2. Plug the prongless end of the power cord into the power connector on your expansion box.
3. Plug the pronged end of the cord into the same power source as the one used by your system unit.



DEPI067

Figure 4-12. Connecting an expansion box power cord

4. Turn on the expansion box by pressing the 1 on the on/off switch on the box.

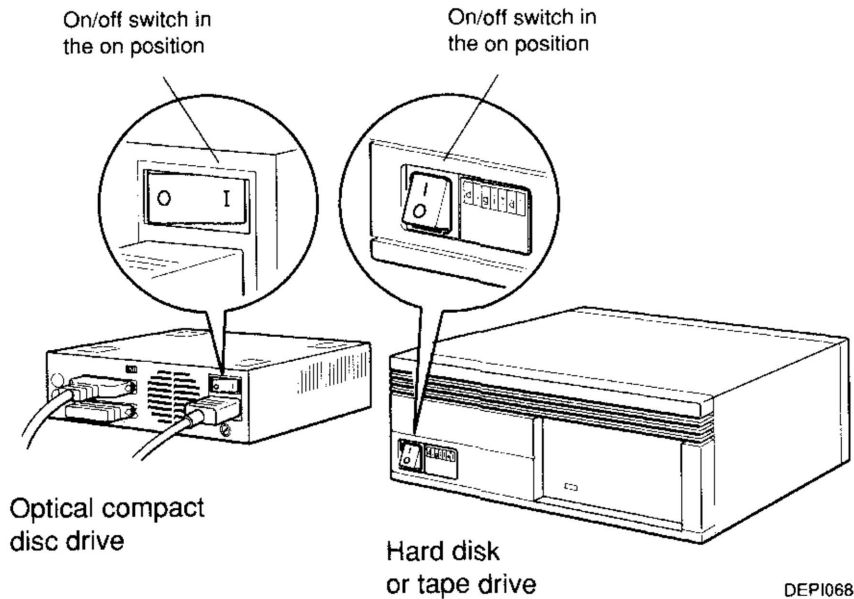

Figure 4-13. Turning on an expansion box

5. Turn on the system unit by pressing the 1 on the on/off switch on the back of the unit.

Your system runs through its self-tests and displays the console prompt (>>) when all the tests are completed successfully.

If a subtest fails,

- a. Turn off your expansion box and system unit.
- b. Check your expansion box connections. Be sure to inspect your connectors for damaged pins.
- c. Turn on the expansion box and system unit again.

If the subtest still fails, contact your Digital service representative.

6. Type **test -c** at the console prompt (>>) and check the configuration display to be sure the system recognizes the device.

To attach boxes after the first

Before you connect any boxes after the first, stack them together, and set the SCSI switches for each box.

To know how to set your SCSI switches, you need to display your configuration table. This table tells you what storage devices your system has and where your storage devices are located.

Reading the configuration table

Type **test -c** at the console prompt (>>) and press Return to display your configuration table.

A display similar to that in Figure 4-14 should appear on your screen. This display is described in detail on the next page.

```
MEM: 16Mbytes
VIDEO: MONO
ETHERNET STA ADDR: 08-00-2b-0d-f7-6a
SCSI DEVS:
U[7]
U[6]KN01--SII
U[5]
U[4]
U[3] Dev typ 0 RZ
      RMB                0x0
      Vrs                 1
      Format               1   CCS
      Add len              31
      Vndr                 DEC
      PID                  RZ23   (C) DEC
      Frevlvl              0618
U[2]
U[1]
U[0]
>>
```

Figure 4-14. Sample configuration display

From the configuration display, you learn the following:

Line 1 — Tells you how much memory you have. The system described in the figure has 16 megabytes of memory. You could add one or two 4-megabyte memory modules to this system.

Line 2 — Tells you what kind of monitor you have. For a monochrome monitor, this line reads VIDEO: MONO. For a color monitor, this line reads VIDEO: COLOR.

Line 3 — Tells you your Ethernet station address. The address for the system described in the figure is 08-00-2b-0d-f7-6a. You need to know your Ethernet address to connect your workstation to a network.

Line 4 — Introduces the list of storage-device locations available in your system. These storage devices are called small computer system interface (SCSI) devices. The remaining lines of this display describe any SCSI devices assigned to units 7 through 0.

Line 5 — Tells you that the system described in the figure has nothing assigned to unit 7. Leave this unit empty. Assigning a storage device to unit 7 can cause the system to malfunction.

Line 6 — Tells you that unit 6 contains the controller that directs the operation of your SCSI devices.

Lines 7, 8 — Tell you that the system described in the figure has nothing assigned to units 5 and 4. You could add storage devices here.

Line 9 — The system in the figure has a hard disk drive assigned to unit 3. The words Device type 0 DISK appear on the unit-number line for any unit that contains a hard disk. If unit 3 contained a tape drive, the words Device type 1 TAPE would appear on the unit-number line. If unit 3 contained an optical compact disc drive, the words Device type 5 ROM DISK would appear on the unit-number line.

Lines 10–16 — Describe the SCSI device assigned to that unit in more detail.

- If you have a hard disk drive, line 6 in column 2 shows the type of drive you have.
 - For an internal disk drive, that line reads RZ23.
 - For an external disk drive, that line reads RZ55.
- If you have a diskette drive, line 6 in column 2 reads RX23.

Lines 17, 18, 19 — The system described in the figure has no devices assigned to units 2, 1, and 0. You could add storage devices here.

Setting the SCSI switches

Now that you know where you can add your storage devices, you can set your SCSI switches.

- If you have a tape drive it should be your first box. Set its switches

Down Up Down

- If you have no tape drive and your first box is a hard disk drive, the settings for that box are

Down Down Down

- If you have no tape drive and your first box is an optical compact disc drive, the settings for that box are

Up Down Down Down

You can decide which ID number to assign to each box after the first.

Set the SCSI ID switches on the back of your expansion boxes according to Table 4-1.

Table 4-1. SCSI ID Switch Settings

Location	TK Tape Drive	RZ Hard Disk or RRD40 Compact Disc ¹
Unit 7	Not available	Not available
Unit 6	Not available	Not available
Unit 5	<i>Down Up Down</i>	<i>Up Down Up</i>
Unit 4	Down Up Up	Up Down Down
Unit 3	Up Down Down	Down Up Up
Unit 2	Up Down Up	Down Up Down
Unit 1	Up Up Down	Down Down Up
Unit 0	Up Up Up	Down Down Down

¹Because switch 4 on the optical compact disc is not used, its position has no effect on the ID number.

Connecting boxes

Caution: *Using cables other than the Digital-supplied 18-inch cable between expansion boxes can cause the boxes to malfunction.*

1. Plug one end of the 18-inch expansion box cable into the free connector on the back of the first expansion box.

If your expansion box is a disk or tape drive, slide the free end of the cable up between the next expansion box and its handle.

2. Plug the free end of the cable into one of the connectors on the next box, as shown in Figure 4-15.

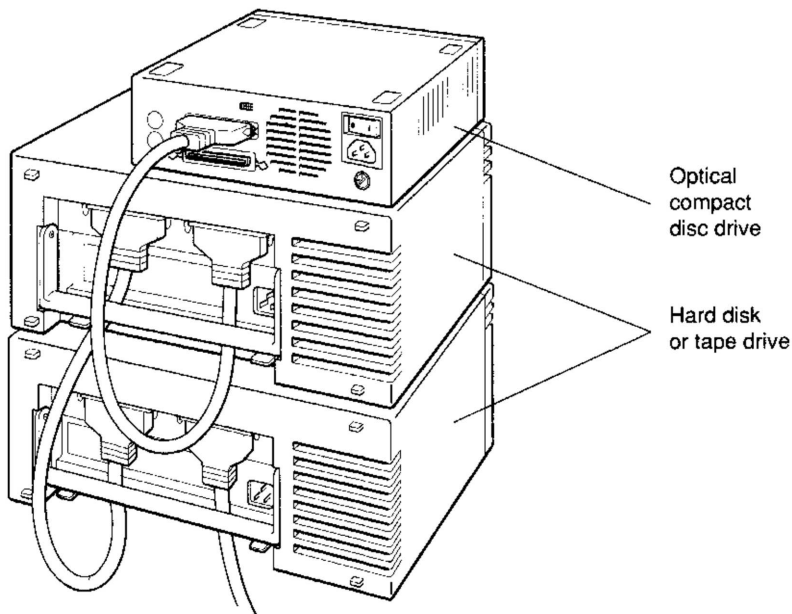

DEPI069

Figure 4-15. Connecting an expansion box to another expansion box

3. Repeat steps 2, 3, and 4 for each additional box.
4. Attach the terminator that came with your expansion boxes to the empty connector on your final box, as shown in Figure 4-16.
 - a. Press the two wire brackets on the empty connector away from the connector.
 - b. Position the terminator so the widest part of its connector aligns with the widest part of the connector on the box.
 - c. Push the terminator into the expansion box connector as far as it will go.
 - d. Press the two wire brackets firmly against the sides of the terminator until they click into the grooves on the terminator.

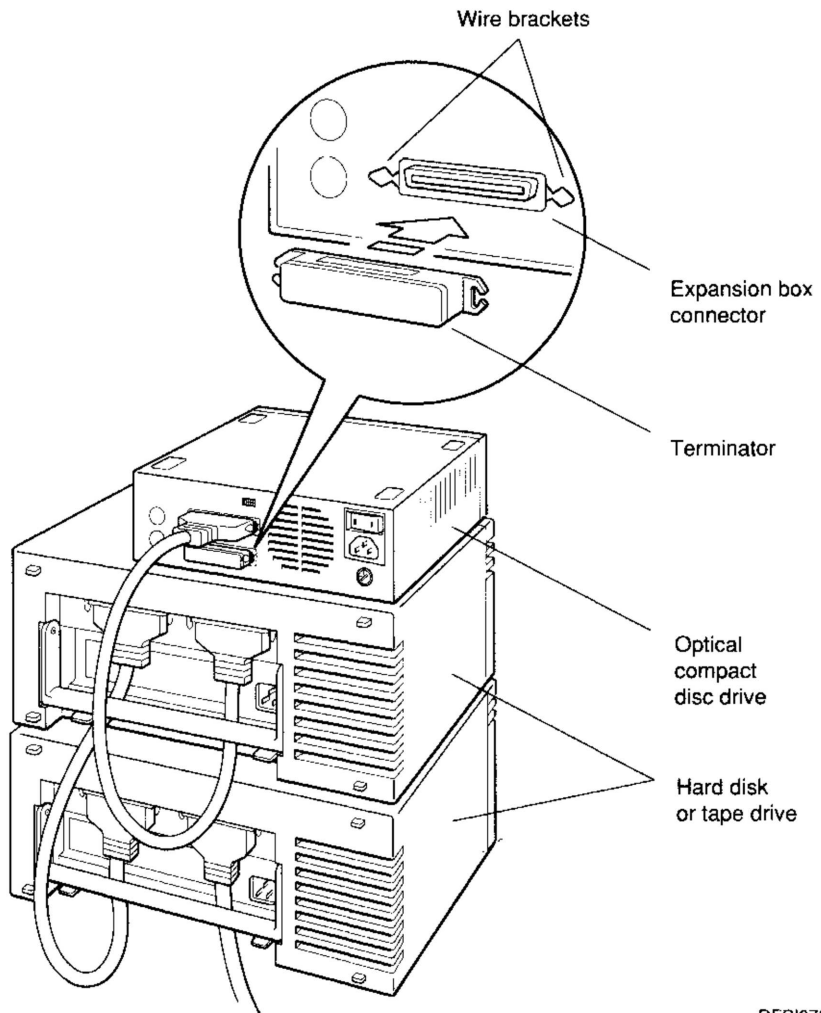

DEPI070

Figure 4-16. Terminating the final expansion box

5. Plug the prongless end of the power cord into the power connector on each expansion box.

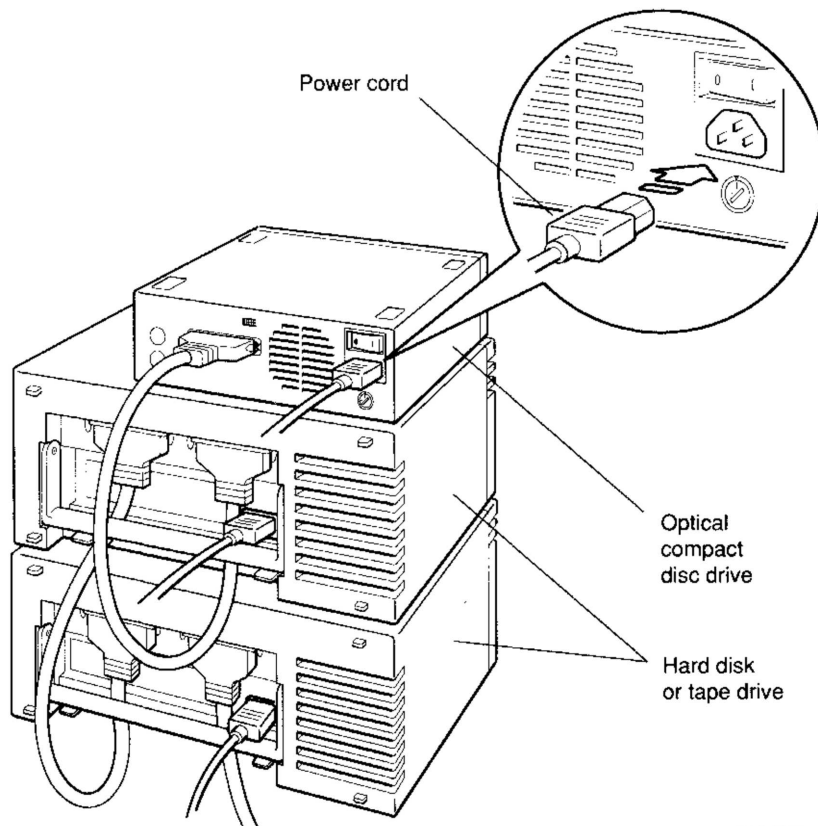

DEPI071

Figure 4-17. Connecting the power cord

6. Plug the pronged end of the cord into the power source.

Note: *Because you are installing more than one box, the power source for your system unit and expansion boxes should be one common power strip.*

7. Be sure the voltage-selection switch on your optical compact disc drive is set for the same voltage as that of your power source.

Caution: Connecting an expansion box to a power source that does not meet the voltage requirements of the box can damage the device inside that box.

8. Turn on each expansion box by pressing the 1 on the on/off switch on the box.

After this first time, turn your expansion boxes on and off by using the on/off switch on your power strip.

9. Turn on the system unit by pressing the 1 on the on/off switch on the back of the unit.

After this, turn your system unit on and off by using the on/off switch on your power strip.

Your system performs its self-test and displays the console prompt (>>) when all the subtests are completed successfully.

If a subtest fails,

- a. Turn off your system by using the on/off switch on your power strip.
- b. Check your expansion box connections. Be sure to inspect your connectors for damaged pins.
- c. Use the on/off switch on your power strip to turn your system on again.

If the subtest still fails, contact your Digital service representative.

10. Type **test -c** at the console prompt (>>) and check your configuration display to be sure your system recognizes each device.

Installing a Printer

When you ordered your printer, you may also have ordered a serial line cable. If you have one, you connect one end of this cable to your printer cable and the other end to your system unit.

1. Find your serial line cable if one came with your shipment.
2. Follow the instructions that came with your printer to perform these tasks:
 - Be sure the printer is turned off.
 - Set up the printer and attach the cable that came with it.
 - Set the proper baud rate and control settings.
3. Turn off the system unit by pressing the 0 on the on/off switch on the back of the system unit or, if you have a power strip, by turning off the power strip.
4. If you have a serial line cable, attach one end of it to the free end of the printer cable.
5. Position the connector on your printer cable, or on the free end of the serial line cable, so the clip is down.
6. Push the cable connector into the connector under the printer icon on the back of the system unit, as shown on Figure 4-18.

The connector clicks into place.

7. Plug the power cord into the power source.
8. Turn on the printer.
9. Turn on the system unit by pressing the 1 on the on/off switch or by turning on the power strip.

Your system performs its self-test and displays the console prompt (>>) when all the subtests are completed successfully.

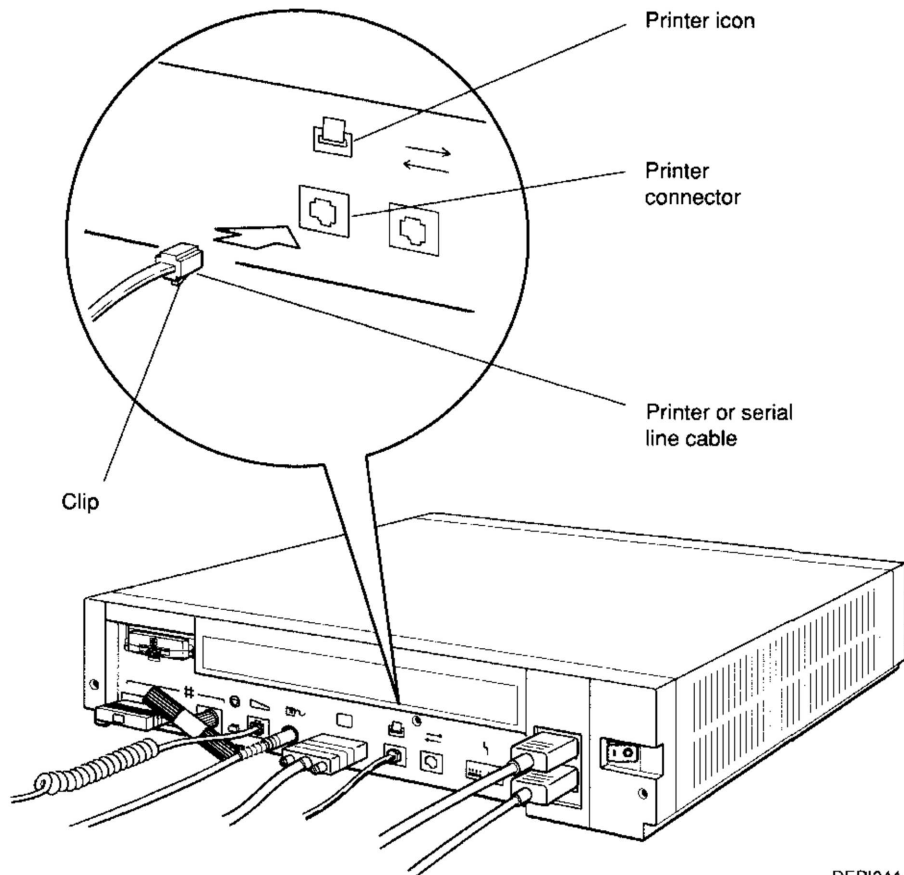

DEPI044

Figure 4-18. Connecting a printer to the system unit

If a subtest fails,

- a. Turn off your printer and system unit.
- b. Check your printer connections.
- c. Turn your printer and system unit on again.

If the subtest still fails, contact your Digital service representative.

See the documentation that came with your operating system for instructions on setting the correct baud rate in the DECstation 2100/3100 environment variables.

Installing a Communications Device

When you ordered your communications device, you may also have ordered a serial line cable with which to connect the device to your system unit.

1. If you ordered one, find the serial line cable that came with your shipment.
2. Follow the instructions that came with your device to perform these tasks:
 - Be sure the device is turned off.
 - Set up and attach the device to the cable that came with it.
 - Set the proper baud rate and control settings.
3. Turn off the system unit by pressing the 0 on the on/off switch on the back of the system unit or, if you have a power strip, by turning off the power strip.
4. If you have a serial line cable, attach one end of it to the free end of the device cable.
5. Position the connector on your device cable, or on the free end of your serial line cable, so the clip is down.
6. Push the cable connector into the connector under the communications icon on the back of the system unit as shown in Figure 4-19.
7. Plug the power cord into the power source.
8. Turn on the device by pressing the 1 on the on/off switch.
9. Turn on the system unit by pressing the 1 on the on/off switch or by turning on the power strip.

Your system performs its self-test and displays the console prompt (>>) when all the subtests are completed successfully.

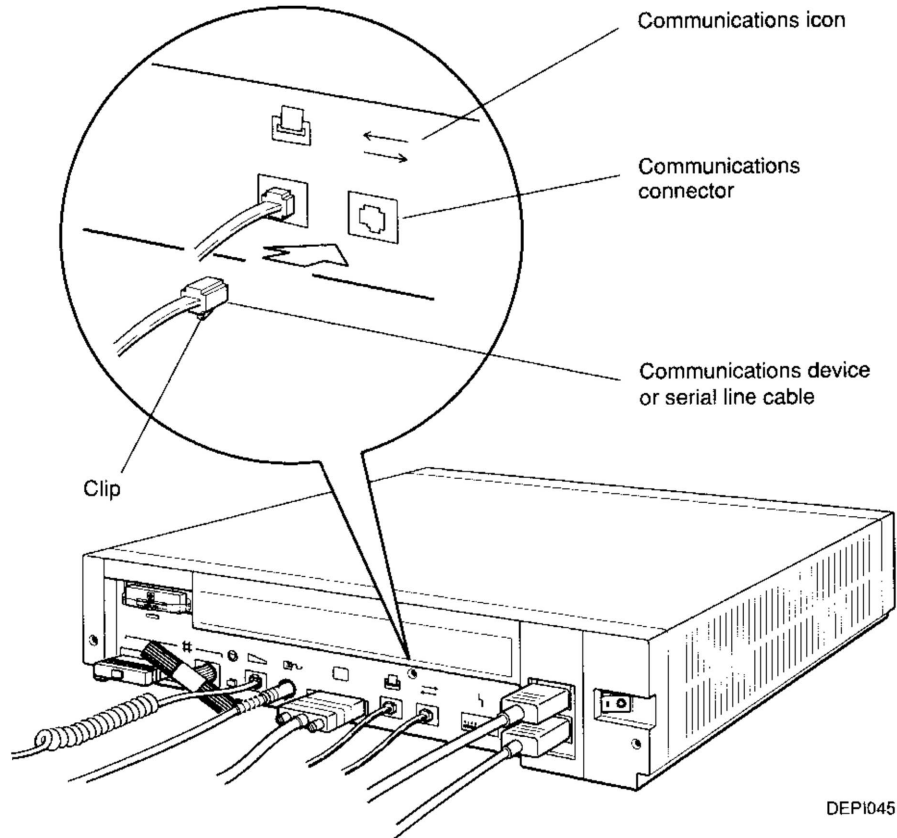

Figure 4-19. Connecting a communications device to the system unit

If a subtest fails,

- a. Turn off your device and system unit.
- b. Check your device connections.
- c. Turn your device and system unit on again.

If the subtest still fails, contact your Digital service representative.

See the documentation that came with your operating system for instructions on setting the correct baud rate in the DECstation 2100/3100 environment variables.

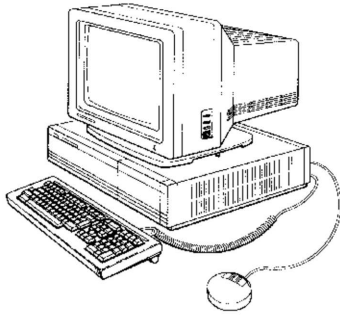

Completing the Hardware Installation

This chapter tells you

- How to gather the information you need to begin installing your worksystem software
- Where to learn how to install your applications software

***Important:** If line 1 of your power-up screen displays KN01 V6.5 or a lower version number, and any diagnostic command is issued, issue a hardware reset or an init command before attempting a boot or an auto command.*

Using Ethernet to Access Your Worksystem Software

If you want to use Ethernet to access your worksystem software, make sure your system manager has your Ethernet station address to register you to do so. Ask your system manager for instructions on how to boot your worksystem software.

Installing Your Worksystem Software on a Hard Disk

Using a Tape Drive

When using a tape drive to install an operating system on a hard disk, you need the following:

- A TK50Z tape drive
- The ULTRIX TK50Z tape cartridge kit
- An RZ55 hard disk drive

***Note:** Your hard disk drive is formatted (ready to receive information) when you receive it from the factory.*

In addition, you need to know

- The unit number of your tape drive
- How to use tape cartridges

See Chapter 4 of the *DECstation 2100/3100 Operator's Guide* or the documentation that came with your tape drive for instructions on using tape cartridges.

To find the unit number of your tape drive

Type **test -c** at the console prompt (>>) and press Return.

A display similar to the one in Figure 5-1 appears on the screen.

```
MEM: 16Mbytes .
VIDEO: MONO
ETHERNET STA ADDR: 08-00-2b-0d-f7-6a
SCSI DEVS:
U[7]
U[6]KN01--SII
U[5] Dev typ 1 TZ
          RMB                      0xd0 rmv mda TZK50
          Vrs                      1
          Format                    0
          Add len                   0
U[4]
U[3]
U[2]
U[1]
U[0]
>>
```

Figure 5-1. Sample configuration display

Line 4 of this display introduces the list of hard disk and tape drives installed as part of your system.

- For hard disk drives or diskette drives, the following appears on the line that contains the unit number:

```
Dev typ 0 RZ
```

To determine whether the device is a hard disk or a diskette drive, look at the right-hand column under the unit-number line. If you have a diskette drive, the second-to-last line reads

```
RX23
```

- For tape drives, the following appears on the line that contains the unit number:

```
Dev typ 1 TZ
```

In the sample display in Figure 5-1, you can see that unit 5 contains a tape drive.

To install your worksystem software, turn to “Where to Go from Here” later in this chapter.

Using Ethernet

When using Ethernet to install an operating system on a hard disk, you need the following:

- A connection to Ethernet
- An RZ55 hard disk drive

***Note:** Your hard disk drive is formatted (ready to receive information) when you receive it from the factory.*

Ask your system manager to tell you when the remote installation service on the Ethernet server is ready so you can install your operating system.

Where to Go from Here

To Perform Basic Worksystem Software Installation

1. Read the release notes.
2. Follow the instructions provided in the *ULTRIX Basic Installation Guide*.

Note: *If you plan to use a tape drive to perform the basic installation you need to use the external RZ55 hard disk drive.*

To Tailor Your Worksystem Software to Meet Special Needs

1. Read the release notes.
2. Perform the basic operating system installation as described in the *ULTRIX Basic Installation Guide*, until the guide asks you to choose the type of installation.
3. Then follow the instructions provided in the *ULTRIX Advanced Installation Guide*.

To Install Application Software Products

Follow the instructions in the installation guides that came with your software.

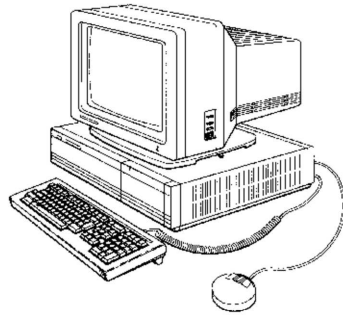

Installation Notes for Experienced Installers

The instructions given here assume that all power cords remain unplugged until step 10 and that power switches remain in the off (0) position until step 12.

***Warning:** Turning on power before you are instructed to do so can cause injury and damage equipment.*

Installing the Basic DECstation 2100/3100

1. Review site requirements.
2. Unpack and check your shipment.
3. Set up the system unit.
4. Connect the video cable.
5. Attach the keyboard cable to the back of the system unit at the keyboard icon.
6. Attach the mouse cable to the back of the system unit at the mouse icon.
7. Connect the SCSI terminator to the SCSI connector on the system unit.
8. Install the ThickWire Ethernet loopback connector and terminate ThinWire Ethernet.

9. Set up the monitor.

Use the knob with the short screw for both 15-inch monitors and for the 19-inch monochrome monitor. Use the knob with the long screw for the 19-inch color monitor.

10. Connect the monitor-system unit power cable.

Caution: *Connecting the monitor to a system unit that is receiving power from a source that does not meet the voltage requirements of the monitor can damage the monitor.*

11. Connect the system unit power cord.

12. Turn on the DECstation by first turning on the monitor and then the system unit.

13. Check the results of the power-up self-test.

- If the testing is successful, the monitor shows a display similar to the following:

```
KN01 V6.71  
08-00-2b-0d-f7-6a  
0x01000000  
>>
```

- If the monitor screen remains blank, contact your system manager or refer to the troubleshooting chapter in the *DECstation 2100/3100 Operator's Guide*.

14. Give your Ethernet station address to your system manager.

Type **test -c** at the console prompt.

15. Install any optional peripheral devices according to the instructions given in "Installing Optional Peripheral Devices," the next section of this chapter.

16. Install your software.

Installing Optional Peripheral Devices

Caution: *Attaching a peripheral device to the wrong connector on the system unit can damage the system unit and peripheral device.*

To Install External Storage Devices

If you connect more than one external storage device to your workstation, use one common power strip as your power source.

Caution: *Using different power sources for different storage devices can damage your equipment.*

Connecting an expansion box to the system unit

1. Set up the device and be sure the SCSI switches on the back of the box are set correctly.
 - If your first box is a tape drive, the settings are
Down Up Down
 - If your first box is a hard disk drive, the settings are
Down Down Down
 - If your first box is an optical compact disc drive, the settings are
Up Down Down Down
2. Attach the cable with two different connectors on it to the SCSI connector on the system unit and to one of the connectors on the back of the box.
3. If you are not attaching another expansion box, plug the SCSI terminator into the empty connector on the expansion box.

Connecting boxes after the first

1. Stack the boxes on top of the first box.

Note: *If you use an optical compact disc drive, always connect it last.*

2. Set the SCSI switches for each box
 - a. Type **test -c** to display the configuration table.

- b. Use the SCSI ID switch settings listed in Table 4-1 earlier in this guide.
3. Use the 18-inch expansion box cable with identical connectors at each end to connect the new expansion box to the installed box.

Caution: Using a cable other than the Digital-supplied 18-inch cable between expansion boxes can cause the boxes to malfunction.

Repeat this step for each additional box.

4. Plug the expansion box terminator into the empty connector on your final box.

To Install a Printer

1. Set up the printer and its cable according to the instructions that came with it.
2. Attach the printer cable to the back of the system unit at the printer icon.

See the documentation that came with your operating system for instructions on setting the baud rate in the DECstation 2100/3100 environment variables.

To Install a Communications Device

1. Set up the device and its cable according to the instructions that came with it.
2. Attach the communications device connector to the back of the system unit at the communications icon.

See the documentation that came with your operating system for instructions on setting the baud rate in the DECstation 2100/3100 environment variables.

A

Ethernet Hardware Connections

This appendix tells you how to prepare your workstation for connection to ThinWire or ThickWire Ethernet.

If you have a ThickWire network, follow the instructions on page A-2. If you have a ThinWire network, turn to page A-4.

Connecting to a ThickWire Network

When connecting your workstation to a ThickWire network, you must have a 15-pin Ethernet cable.

To connect to a ThickWire network,

1. Turn off the system unit by pressing the 0 on the on/off switch on the back of the unit.
2. Position the cable connector so the widest part of the connector aligns with the widest part of the connector on the system unit.
3. Push the cable connector into the ThickWire connector, as shown in Figure A-1.
4. Find the slide latch, located at the right of the ThickWire connector.
5. Push it all the way to the left to lock the ThickWire cable connector in place.
6. Turn on the system unit by pressing the 1 on the on/off switch.

A light between the ThickWire Ethernet connector and the Ethernet button should glow green.

- If the light fails to glow, use the point of a ballpoint pen, or some similar tool, to press and release the Ethernet button, located to the right of the ThickWire connector.

Caution: *The graphite in pencil lead can damage the system unit.*

- If the light still fails to glow, contact your Digital service representative.
7. Complete the network installation according to the instructions provided in the networking guide for your operating system.

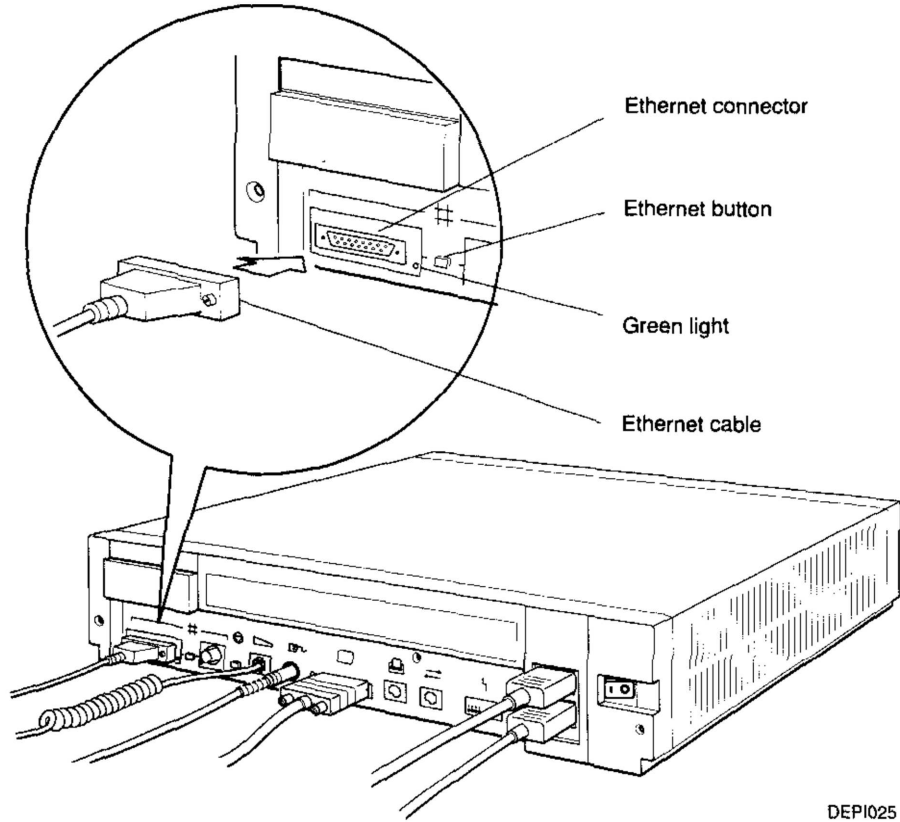

DEPI025

Figure A-1. Connecting the ThickWire ethernet cable

Connecting to a ThinWire Network

When connecting your workstation to the end of a ThinWire cable segment, you need one ThinWire cable. When connecting within a ThinWire cable segment, you need two ThinWire cables.

To connect to the end of a ThinWire segment, follow the instructions on page A-5.

To connect within a ThinWire segment, follow the instructions on page A-8.

To Connect to the End of a ThinWire Segment

1. Turn off the system unit by pressing the 0 on the on/off switch on the back of the system unit.
2. Remove one terminator from the T-connector.

Turn the left-hand terminator away from you or the right-hand terminator toward you until you can pull it away from the T-connector.

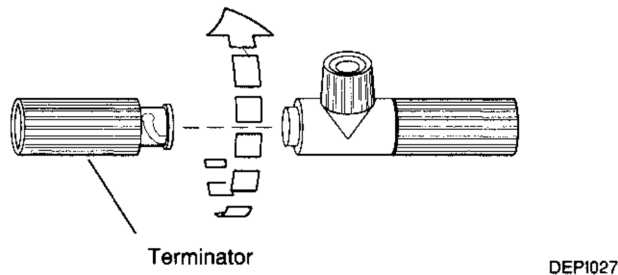

Figure A-2. Removing a Terminator from the T-Connector

3. Attach the cable connector to the free end of the T-connector.

Firmly push the cable connector into the T-connector and twist the cable connector until it slides forward and locks into place.

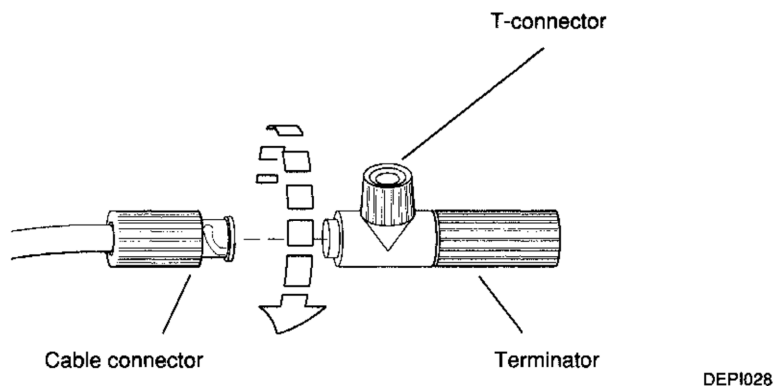

Figure A-3. Connecting the ThinWire Cable to the T-Connector

4. Push the ribbed portion of the T-connector into the ThinWire Ethernet connector below the Ethernet icon on the back of the system unit.
5. Twist the T-connector from side to side until it slips into place and you can push it onto the connector on the system unit.
6. Twist the ribbed portion of the connector to the right until it locks into place.

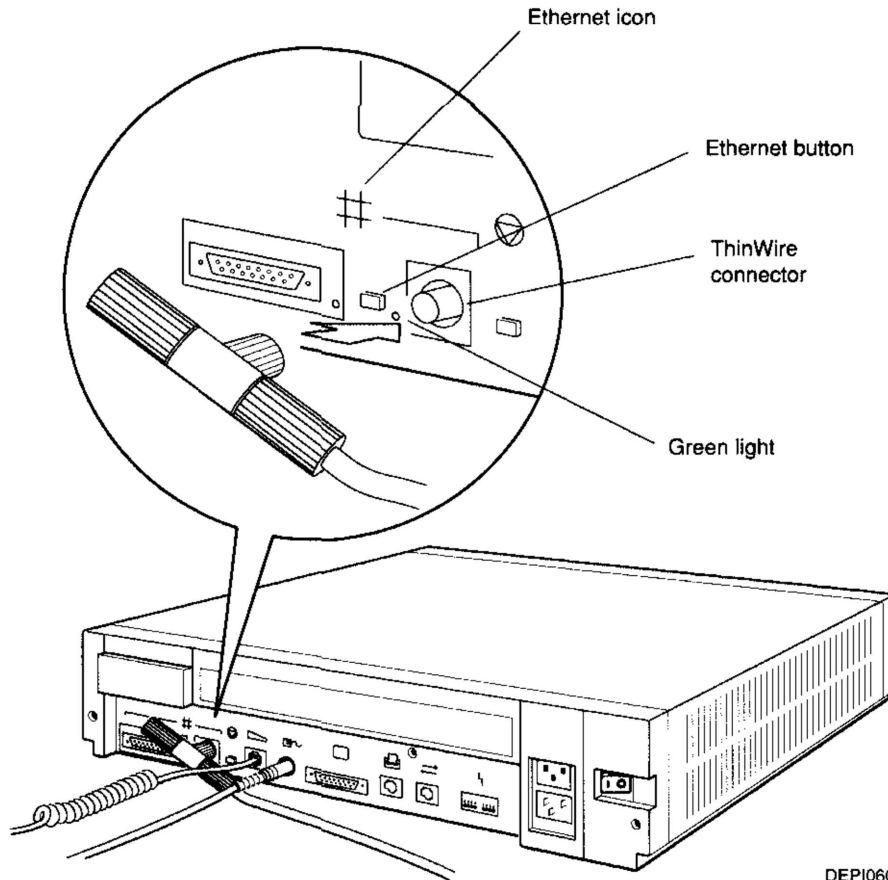

Figure A-4. Connecting one ThinWire cable

DEPI060

7. Turn on the system unit by pressing the 1 on the on/off switch.

A light should glow green to the left of the T-connector.

- If the light fails to glow, use the point of a ballpoint pen, or some similar tool, to press and release the Ethernet button, located to the left of the ThinWire connector.

Caution: *The graphite in pencil lead can damage the system unit.*

- If the light still fails to glow, contact your Digital service representative.
8. Complete the network installation according to the instructions provided in the networking guide for your operating system.

To Connect Within a ThinWire Segment

1. Turn off the system unit by pressing the 0 on the on/off switch on the back of the unit.
2. Remove both terminators from the T-connector.

Turn the right-hand terminator toward you and the left-hand terminator away from you until you can pull them away from the T-connector.

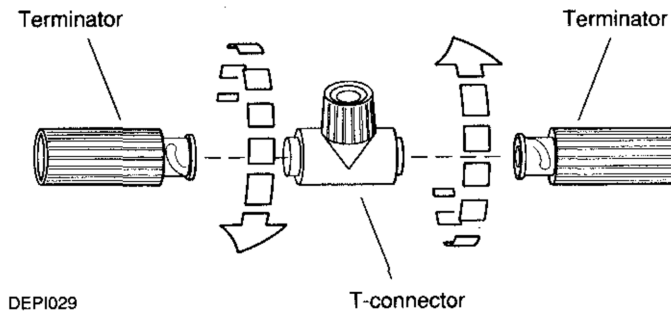

Figure A-5. Removing the Terminators from the T-Connector

3. Attach the cable connectors to the T-connector.

Firmly push each cable connector into the T-connector and twist the cable connector until they slide forward and lock into place.

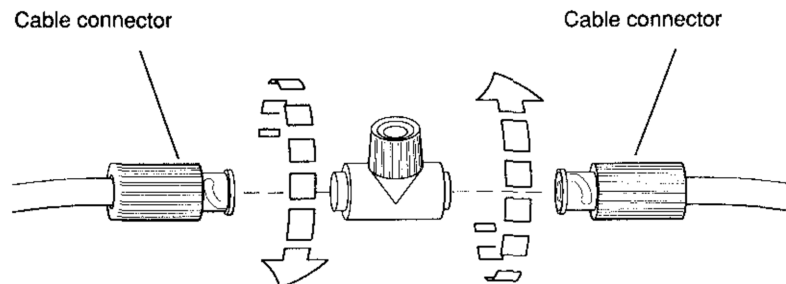
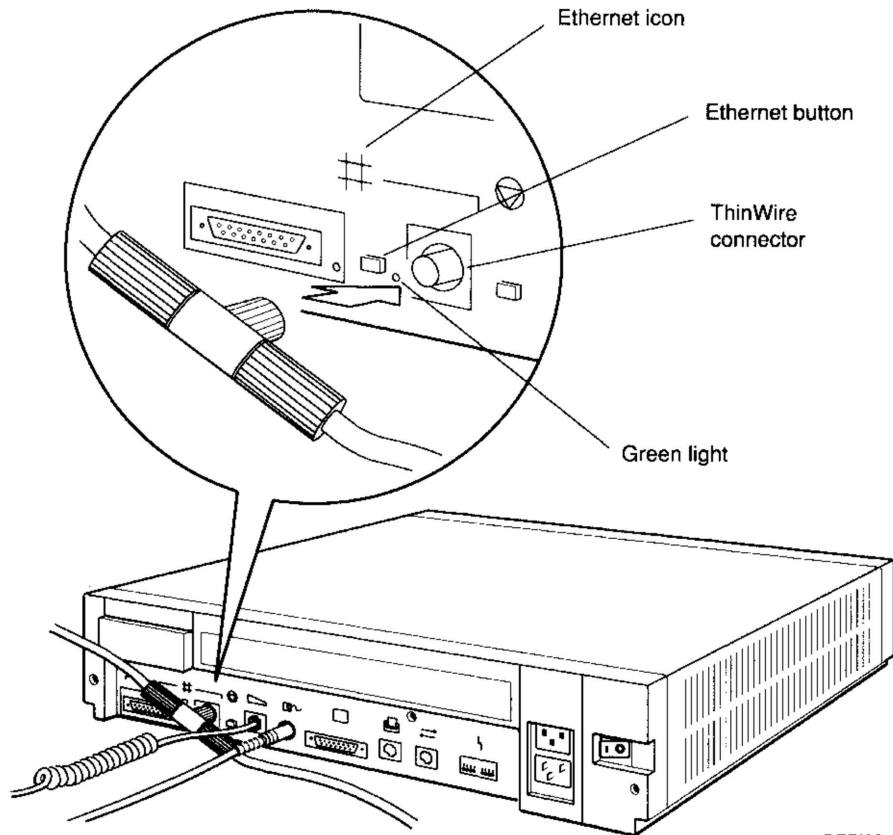

Figure A-6. Connecting the ThinWire Cables to the T-Connector

4. Push the ribbed portion of the T-connector into the ThinWire Ethernet connector below the Ethernet icon on the back of the system unit.
5. Twist the T-connector from side to side until it slips into place and you can push it onto the connector on the system unit.
6. Twist the ribbed portion of the connector to the right until it locks into place.



DEPI061

Figure A-7. Connecting two ThinWire cables

7. Turn on the system unit by pressing the 1 on the on/off switch.

A light should glow green to the left of the T-connector.

- If the light fails to glow, use the point of a ballpoint pen, or some similar tool, to press and release the Ethernet button, located to the left of the ThinWire connector.

Caution: The graphite in pencil lead can damage the system unit.

- If the light still fails to glow, contact your Digital service representative.
8. Complete network installation according to the instructions provided in the networking guide for your operating system.

Reader's Comments

DECstation 2100/3100 Hardware Installation Guide

Order No: EK-290AB-IN-002

Your comments and suggestions will help us in our continuous effort to improve the quality and usefulness of our publications.

What is your general reaction to this manual?

	Excellent	Very Good	Good	Fair	Poor
Accuracy					
Completeness					
Organization					
Format					

Does the publication satisfy your needs? Yes No

How or How not?

What errors have you found? (Reference page number, table number, figure number.)

Please write additional comments on the back of this form.

Name _____ Title _____
Department _____ Company _____
Street _____ City _____
State-Country _____ Zip _____

Return with your comments and suggestions to:

Digital Equipment Corporation
Workstation Systems Engineering
Documentation Department
100 Hamilton Avenue (UCO-2)
Palo Alto, CA 94301