

# **VAX 8820/8830/8840 System Hardware User's Guide**

Order Number: EK-8840H-UG-001

**Prepared by Educational Services  
of  
Digital Equipment Corporation**

---

**March, 1988**

---

The information in this document is subject to change without notice and should not be construed as a commitment by Digital Equipment Corporation. Digital Equipment Corporation assumes no responsibility for any errors that may appear in this document.

The software described in this document is furnished under a license and may be used or copied only in accordance with the terms of such license.

No responsibility is assumed for the use or reliability of software on equipment that is not supplied by Digital Equipment Corporation or its affiliated companies.

---

Copyright ©1988 by Digital Equipment Corporation

All Rights Reserved.  
Printed in U.S.A.

---

The following are trademarks of Digital Equipment Corporation:

|           |              |                   |
|-----------|--------------|-------------------|
| BASEWAY   | MASSBUS      | RSX               |
| BI Bus    | Micro/RSTS   | RT                |
| DEC       | MicroPDP-11  | UNIBUS            |
| DEC/MAP   | Micro/R SX   | VAX               |
| DECmate   | MicroVAX II  | VAXcluster        |
| DECnet    | PDP          | VAXstation II     |
| DECUS     | P/OS         | VAXstation II/GPX |
| DECwriter | Professional | VMS               |
| DIBOL     | Q-bus        | VT                |
| EDCS      | Rainbow      |                   |
| FMS       | RSTS         |                   |

**digital**™

# CONTENTS

## CHAPTER 1 INTRODUCTION

|     |  |     |
|-----|--|-----|
| 1.1 | VAX 8820/8830/8840 SYSTEM OVERVIEW . . . . . | 1-1 |
| 1.2 | SCOPE . . . . .                              | 1-1 |
| 1.3 | INTRODUCTION . . . . .                       | 1-5 |
| 1.4 | PHYSICAL DESCRIPTION . . . . .               | 1-5 |
| 1.5 | ENCLOSURES . . . . .                         | 1-9 |

## CHAPTER 2 VAX 8820/8830/8840 SYSTEM OPERATION

|         |  |      |
|---------|--|------|
| 2.1     | INTRODUCTION . . . . .                             | 2-1  |
| 2.2     | SYSTEM SETUP AND PREPARATION FOR USE . . . . .     | 2-1  |
| 2.2.1   | Input Power . . . . .                              | 2-1  |
| 2.2.2   | Primary System Power . . . . .                     | 2-2  |
| 2.2.2.1 | Power Breakers . . . . .                           | 2-3  |
| 2.2.2.2 | Starting the Console Subsystem . . . . .           | 2-3  |
| 2.2.3   | Turning System Power On/Off . . . . .              | 2-6  |
| 2.2.3.1 | Power On . . . . .                                 | 2-6  |
| 2.2.3.2 | System Initialization . . . . .                    | 2-9  |
| 2.2.3.3 | System Boot . . . . .                              | 2-12 |
| 2.2.3.4 | System Initialization and Autoboot . . . . .       | 2-15 |
| 2.2.3.5 | System Power Down . . . . .                        | 2-18 |
| 2.2.3.6 | Powerfail and Standby Modes . . . . .              | 2-19 |
| 2.2.3.7 | Warm Restart . . . . .                             | 2-20 |
| 2.3     | OPERATOR/CONSOLE INTERACTION . . . . .             | 2-22 |
| 2.3.1   | Console Command Language Display Prompts . . . . . | 2-22 |
| 2.3.2   | Console Commands . . . . .                         | 2-22 |
| 2.4     | CONSOLE DISPLAYS AND LOG FILES . . . . .           | 2-27 |
| 2.4.1   | System Log File . . . . .                          | 2-27 |
| 2.4.1.1 | Starting the log file . . . . .                    | 2-28 |
| 2.4.1.2 | Size and Number of Log Files . . . . .             | 2-28 |
| 2.4.1.3 | Examining the Log File . . . . .                   | 2-28 |
| 2.5     | THE STAR PROCESS . . . . .                         | 2-28 |

**CHAPTER 3 FUNCTIONAL DESCRIPTION**

|         |   |      |
|---------|---|------|
| 3.1     | OVERVIEW . . . . .                                  | 3-1  |
| 3.2     | CONSOLE SUBSYSTEM . . . . .                         | 3-3  |
| 3.2.1   | Console Subsystem Hardware . . . . .                | 3-5  |
| 3.2.1.1 | The MicroVAX II System . . . . .                    | 3-5  |
| 3.2.1.2 | The Q-bus Control Module (QC, M7553) . . . . .      | 3-6  |
| 3.2.1.3 | The Console Interface Module (CIM, F1032) . . . . . | 3-6  |
| 3.2.2   | Console Subsystem Software . . . . .                | 3-6  |
| 3.2.2.1 | Power-up and Boot . . . . .                         | 3-6  |
| 3.2.2.2 | Console I/O Mode . . . . .                          | 3-6  |
| 3.2.2.3 | Program I/O Mode . . . . .                          | 3-6  |
| 3.3     | CENTRAL PROCESSING UNIT . . . . .                   | 3-7  |
| 3.4     | CLOCK MODULE (PCLK) . . . . .                       | 3-9  |
| 3.5     | MEMORY (MBOX) . . . . .                             | 3-10 |
| 3.5.1   | Memory Control Logic . . . . .                      | 3-12 |
| 3.6     | SYSTEM BUSES . . . . .                              | 3-12 |
| 3.6.1   | Memory Interconnect (NMI) . . . . .                 | 3-14 |
| 3.6.2   | VAXBI Interconnect . . . . .                        | 3-16 |
| 3.6.3   | Visibility Bus (VBus) . . . . .                     | 3-18 |
| 3.6.4   | VAXBI Interconnect and I/O Adapters . . . . .       | 3-20 |
| 3.7     | POWER SYSTEM . . . . .                              | 3-23 |
| 3.7.1   | 880A/B Power Controller . . . . .                   | 3-24 |
| 3.7.2   | Solid-State Transformer Box (SST) . . . . .         | 3-26 |
| 3.7.3   | PBox Port Conditioner . . . . .                     | 3-27 |
| 3.7.4   | Module Power Supplies . . . . .                     | 3-27 |
| 3.7.5   | Environmental Monitoring Module . . . . .           | 3-27 |
| 3.7.6   | Battery Backup Unit . . . . .                       | 3-27 |

**CHAPTER 4 VAX 8820/8830/8840 SYSTEM MAINTENANCE**

|       |  |     |
|-------|--|-----|
| 4.1   | INTRODUCTION . . . . .                               | 4-1 |
| 4.2   | PREVENTATIVE MAINTENANCE . . . . .                   | 4-1 |
| 4.3   | CONSOLE SUBSYSTEM HARDWARE SELF-TESTS . . . . .      | 4-1 |
| 4.4   | CORRECTING SIMPLE PROBLEMS . . . . .                 | 4-2 |
| 4.5   | WHAT TO DO IF YOU HAVE TO CALL FOR SERVICE . . . . . | 4-3 |
| 4.6   | REMOTE DIAGNOSIS . . . . .                           | 4-4 |
| 4.6.1 | Remote Diagnosis Configurations . . . . .            | 4-4 |
| 4.6.2 | Setting Up for a Remote Diagnosis Session . . . . .  | 4-6 |

**Appendix A DF112 MODEM INFORMATION**

|         |   |     |
|---------|---|-----|
| A.1     | Installing the DF112 Modem . . . . .          | A-1 |
| A.1.1   | DF112 Modem Characteristics . . . . .         | A-3 |
| A.1.1.1 | DF112 Modem General Characteristics . . . . . | A-3 |
| A.1.1.2 | Major Features . . . . .                      | A-3 |

## EXAMPLES

|     |  |      |
|-----|--|------|
| 2-1 | Console Display of Console Subsystem Startup . . . . . | 2-5  |
| 2-2 | SYSINIT.CMD Command File . . . . .                     | 2-9  |
| 2-3 | DEFBOO.CMD Command File . . . . .                      | 2-12 |
| 2-4 | BCIBOO.CMD Command File . . . . .                      | 2-13 |
| 2-5 | BDABOO.CMD Command File . . . . .                      | 2-14 |
| 2-6 | AUTO_SYSINIT Command File . . . . .                    | 2-16 |
| 2-7 | RESTAR.CMD Command File . . . . .                      | 2-21 |
| 2-8 | Console Display Showing a Local Operation . . . . .    | 2-27 |

## FIGURES

|      |  |      |
|------|--|------|
| 1-1  | Typical VAX 8820/8830/8840 System . . . . .                    | 1-2  |
| 1-2  | VAX 8820/8830/8840 System Cabinet Layout (Front) . . . . .     | 1-6  |
| 1-3  | VAX 8820/8830/8840 System Cabinet Layout (Back) . . . . .      | 1-7  |
| 2-1  | 880 A/B Power Controller Panel . . . . .                       | 2-2  |
| 2-2  | Location of the Console Power-On Switch . . . . .              | 2-4  |
| 2-3  | MPS Unit Letter Identification . . . . .                       | 2-7  |
| 2-4  | MicroVAX II User Terminal State Flowchart . . . . .            | 2-29 |
| 3-1  | VAX 8820/8830/8840 System Configuration . . . . .              | 3-2  |
| 3-2  | Console Subsystem Block Diagram . . . . .                      | 3-4  |
| 3-3  | VAX 8820/8830/8840 System Processor Block Diagram . . . . .    | 3-7  |
| 3-4  | Clock Generation Block Diagram . . . . .                       | 3-9  |
| 3-5  | Memory Subsystem Block Diagram . . . . .                       | 3-11 |
| 3-6  | System Buses . . . . .   | 3-13 |
| 3-7  | NMI Block Diagram . . . . .                                    | 3-15 |
| 3-8  | VAXBI Block Diagram . . . . .                                  | 3-17 |
| 3-9  | VAX 8820/8830/8840 System Visibility Bus (VBus) . . . . .      | 3-19 |
| 3-10 | VAXBI Optional Adapters . . . . .                              | 3-21 |
| 3-11 | NMI to VAXBI Interconnect Adapter (NBI) . . . . .              | 3-22 |
| 3-12 | Power System Block Diagram . . . . .                           | 3-25 |
| 3-13 | Physical Location of the Power System Components . . . . .     | 3-26 |
| 4-1  | Remote Console Configurations . . . . .                        | 4-5  |
| 4-2  | Remote Services Console Front Panel Switch Locations . . . . . | 4-6  |
| A-1  | DF112 Modem . . . . .  | A-2  |

## TABLES

|     |  |      |
|-----|--|------|
| 1-1 | VAX 8820/8830/8840 System Hardware Manuals . . . . .         | 1-1  |
| 1-2 | VAX 8820/8830/8840 System Related Hardware Manuals . . . . . | 1-1  |
| 1-3 | VAX 8820/8830/8840 System Software Documentation . . . . .   | 1-3  |
| 1-4 | VAX 8820/8830/8840 System Physical Characteristics . . . . . | 1-8  |
| 2-1 | VAX 8820/8830/8840 System Circuit Breakers . . . . .         | 2-3  |
| 2-2 | Module Power Supply Turn on Sequence . . . . .               | 2-8  |
| 2-3 | Module Power Supply Turn off Sequence . . . . .              | 2-19 |
| 2-4 | Power Fail and Standby Modes MPS Turn Off Sequence . . . . . | 2-19 |

## CONTENTS

|     |  |      |
|-----|--|------|
| 2-5 | Console Command Language Prompts . . . . .                 | 2-22 |
| 2-6 | Frequently Used Console Commands . . . . .                 | 2-23 |
| 3-1 | Functional Units and Data Buses . . . . .                  | 3-8  |
| 3-2 | Clock Signals . . . . .                                    | 3-10 |
| 3-3 | PMCL Command Operations . . . . .                          | 3-12 |
| 3-4 | NMI Primary Functions . . . . .                            | 3-16 |
| 3-5 | VAXBI Functions . . . . .                                  | 3-18 |
| 3-6 | Optional VAX Bus Interconnect Adapters . . . . .           | 3-20 |
| 3-7 | PBIA Registers . . . . .                                   | 3-22 |
| 3-8 | NBIB Registers . . . . .                                   | 3-23 |
| 3-9 | Power Distribution by the 880/B Power Controller . . . . . | 3-24 |
| 4-1 | Correcting Simple Problems . . . . .                       | 4-2  |
| A-1 | DF112 Specifications . . . . .                             | A-3  |

# CHAPTER 1 INTRODUCTION

## 1.1 VAX 8820/8830/8840 SYSTEM OVERVIEW

The basic VAX 8820/8830/8840 system is contained in two physical units: a MicroVAX II system, used as the console, and a cabinet arrangement. A typical VAX 8820/8830/8840 system shown in Figure 1-1.

## 1.2 SCOPE

This guide contains basic hardware operating information and customer care and use instructions. Detailed information pertaining to specific areas of hardware, software, or diagnostics can be found in the documentation referenced in Table 1-1, Table 1-2, and Table 1-3.

**Table 1-1 VAX 8820/8830/8840 System Hardware Manuals**

| <b>Document Title</b>  | <b>Document Number</b> |
|--|------------------------|
| <i>VAX 8820/8830/8840 System Installation Guide</i>                          | EK-8840I-IN            |
| <i>VAX 8530/8550/8700/8800/8820/8830/8840 System Diagnostic User's Guide</i> | EK-KA88D-UG            |
| <i>VAX 8820/8830/8840 System Site Planning and Preparation Guide</i>         | EK-8840P-SP            |
| <i>VAX 8820/8830/8840 System Hardware User's Guide</i>                       | EK-8840H-UG            |

**Table 1-2 VAX 8820/8830/8840 System Related Hardware Manuals**

| <b>Document Title</b>                                    | <b>Document Number</b> |
|--|------------------------|
| <i>Installing &amp; Using the LA75 Companion Printer</i> | EK-OLA75-UG            |
| <i>MicroVAX II Owner's Manual</i>                        | AZ-GL1AA-MN            |
| <i>MicroVAX II Technical Manual</i>                      | AZ-GL0AA-MN            |
| <i>TK50 Tape Drive Subsystem User's Guide</i>            | EK-OTK50-UG            |
| <i>DF112 Modem User's Guide</i>                          | EK-DF112-UG            |
| <i>Remote Services Console Field Service Manual</i>      | EK-KCRSC-FS            |
| <i>Remote Services Console User's Guide</i>              | EK-KCRSC-UG            |

**INTRODUCTION**

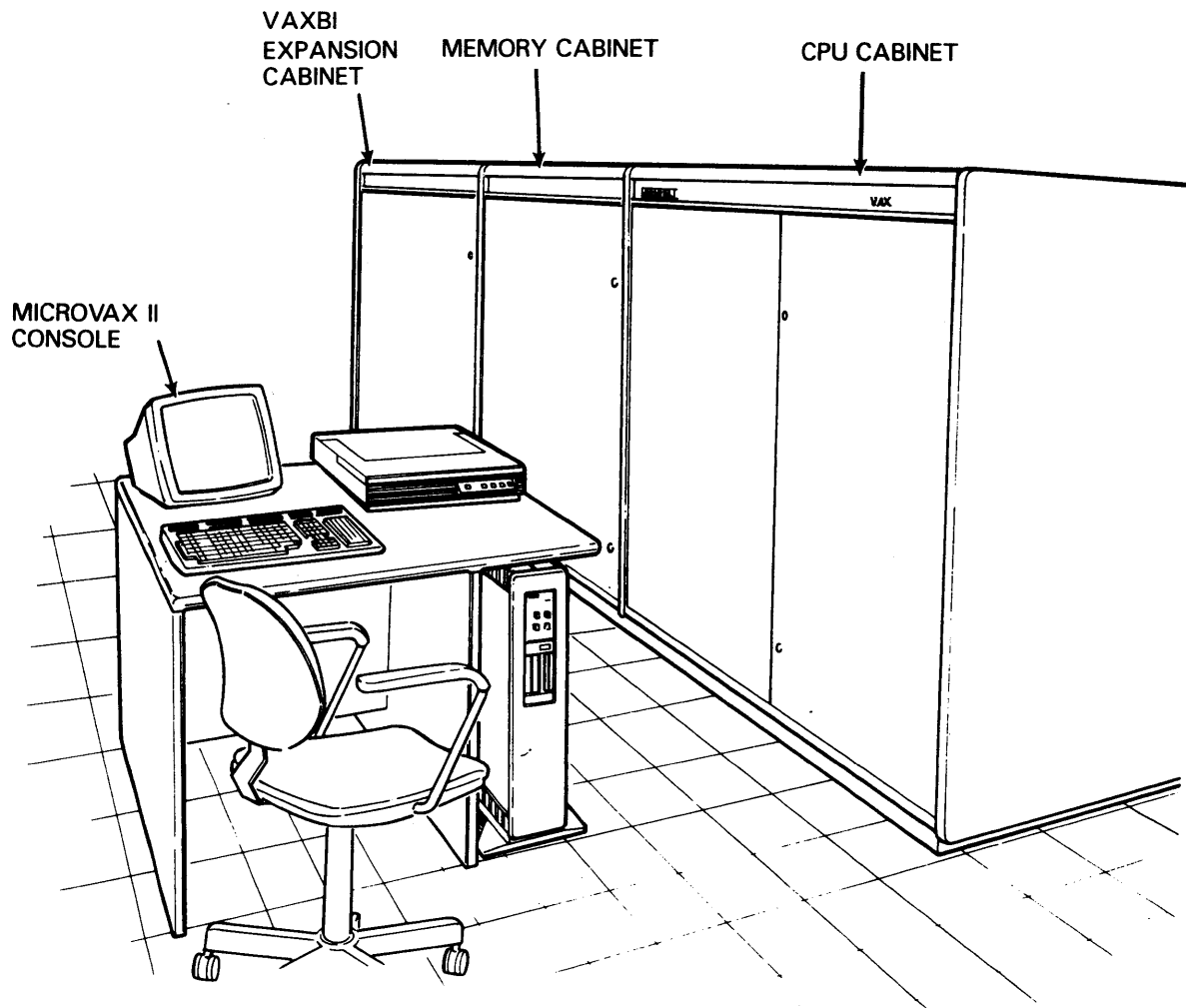

TTB-0257

**Figure 1-1 Typical VAX 8820/8830/8840 System**

Table 1-3 VAX 8820/8830/8840 System Software Documentation

|                                    | Document Title   | Document Number |
|------------------------------------|--|-----------------|
|                                    | <i>VAX 8820/8830/8840 Console User's Guide</i>                   | AA-FJ84A-ME     |
| <b>Volume 1A System Reference</b>  | <i>VAX/VMS Primer</i>  | AA-D030A-TE     |
|                                    | <i>VAX/VMS Summary Description</i>                               | AA-D022A-TE     |
|                                    | <i>VAX/VMS Information Directory</i>                             | AA-D016A-TE     |
|                                    | <i>VAX/VMS Release Notes</i>                                     | AA-D015A-TE     |
|                                    | <i>VAX-11 Software Installation Guide</i>                        | AA-D021A-TE     |
|                                    | <i>VAX/VMS System Services Reference Manual</i>                  | AA-D018A-TE     |
| <b>Volume 1B System Reference</b>  | <i>VAX/VMS Command Language User's Guide</i>                     | AA-D023A-TE     |
|                                    | <i>VAX/VMS Linker Reference Manual</i>                           | AA-D019A-TE     |
|                                    | <i>VAX-11 Symbolic Debugger Reference Manual</i>                 | AA-D026A-TE     |
| <b>Volume 1C System Reference</b>  | <i>VAX-11/RSX-11M Programmer's Reference Manual</i>              | AA-D020A-TE     |
|                                    | <i>VAX-11 MACRO Language Reference Manual</i>                    | AA-D032A-TE     |
|                                    | <i>VAX-11 MACRO User's Guide</i>                                 | AA-D033A-TE     |
| <b>Volume 2A System Procedures</b> | <i>VAX-11 Common Run-Time Procedure Library Reference Manual</i> | AA-D036A-TE     |
|                                    | <i>VAX-11 Text Editing Reference Manual</i>                      | AA-D029A-TE     |
| <b>Volume 2B System Procedures</b> | <i>VAX/VMS Operator's Guide</i>                                  | AA-D025A-TE3    |
|                                    | <i>VAX/VMS System Manager's Guide</i>                            | AA-D927A-TE     |
|                                    | <i>VAX/VMS System Messages and Recovery Procedures Manual</i>    | AA-D017A-TE     |

**INTRODUCTION**

**Table 1-3 (Cont.) VAX 8820/8830/8840 System Software Documentation**

|  | <b>Document Title</b>   | <b>Document Number</b> |
|--|---|------------------------|
|  | <i>VAX/VMS UETP User's Guide</i>                              | AA-D643A-TE            |
|  | <i>VAX-11 Disk Save and Compress User's Guide</i>             | AA-D739A-TE            |
| <b>Volume 3<br/>VAX/VMS<br/>I/O</b>        | <i>VAX/VMS I/O User's Guide</i>                               | AA-D028A-TE            |
|  | <i>Introduction to VAX-11 Record Management Services</i>      | AA-D028A-TE            |
|  | <i>VAX-11 Record Management Services Reference Manual</i>     | AA-D031A-TE            |
|  | <i>VAX-11 Record Management Services User's Guide</i>         | AA-D781A-TE            |
| <b>Volume 4</b>                            | <i>IAS/RSX-11M RMS-11 Macro Programmer's Reference Manual</i> | AA-0002A-TC            |
|  | <i>Introduction to RMS-11</i>                                 | AA-0001A-TC            |
|  | <i>RSX-11 RMS-11 Utilities User's Guide</i>                   | AA-D083A-TC            |
|  | <i>PDP-11 SORT Reference Manual</i>                           | AA-3341C-TC            |
| <b>Volume 5A<br/>Optional<br/>Software</b> | <i>VAX-11 FORTRAN IV-PLUS Language Reference Manual</i>       | AA-D034A-TE            |
|  | <i>VAX-11 FORTRAN IV-PLUS Language User's Guide</i>           | AA-D035A-TE            |

**1.3 INTRODUCTION**

The VAX 8820, VAX 8830, and VAX 8840 systems are LSI-based, high-performance systems compatible with all of the VAX family of 32-bit machines. They combine 32-bit architecture with a virtual memory operating system and memory management (typically using the VAX/VMS Operating System).

The VAX 8820 system uses two CPUs; it can be upgraded to a VAX 8830 system (three CPUs) or a VAX 8840 system (four CPUs) by installing the appropriate upgrade kits. The VAX 8830 system may be upgraded to a VAX 8840 system by installing the appropriate upgrade kit.

VAX 8820/8830/8840 systems support symmetric multiprocessing (SMP), which allows all CPUs to execute most code paths with no restrictions on processor mode. Symmetric multiprocessing makes more efficient use of multiprocessor hardware than asymmetric multiprocessing, increasing the throughput of the multiprocessor system. The term "primary CPU" designates the CPU responsible for controlling synchronization among the CPUs.

The VAX 8820/8830/8840 system hardware contains a native instruction set (microcode) that provides built-in floating-point, packed decimal arithmetic, and character and string manipulation instructions.

**1.4 PHYSICAL DESCRIPTION**

Figure 1-2 and Figure 1-3 show the cabinet layout of the VAX 8820/8830/8840 system and the location of the major components. Table 1-4 provides a list of the physical characteristics.

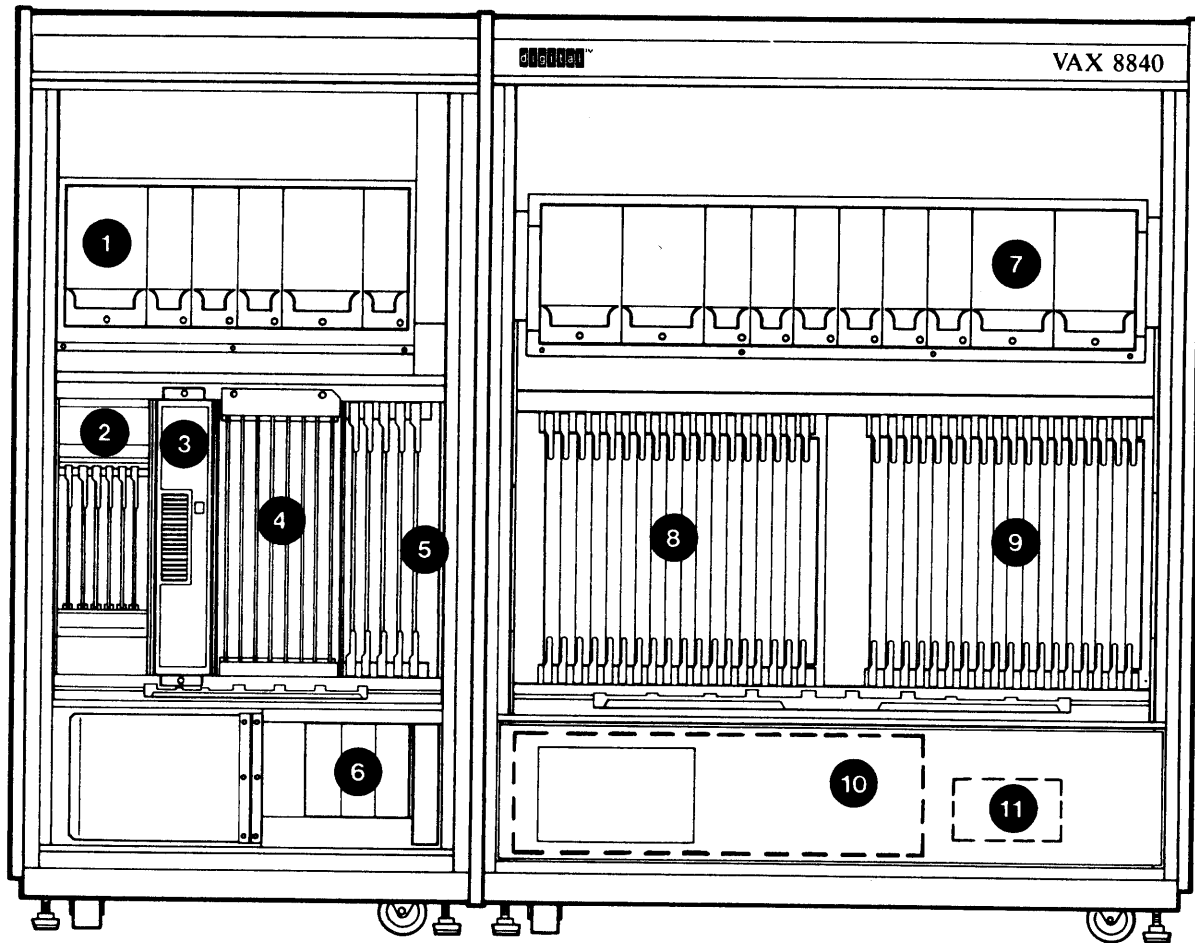

MEMORY CABINET

CPU CABINET

FRONT VIEW

- |   |  |
|---|--|
| <ul style="list-style-type: none"> <li>1. MPS POWER REGULATORS.</li> <li>2. VAXBI</li> <li>3. BATTERY BACKUP UNIT</li> <li>4. MEMORY ARRAY MODULES</li> <li>5. NMI BUS WINDOW (NBW), MEMORY CONTROLLER (PMCL), AND VAXBI INTERFACE (UP TO 3 PBI MODULES).</li> <li>6. PBOX (3 CSP MODULES AND 1 ILM MODULE).</li> </ul> | <ul style="list-style-type: none"> <li>7. MPS POWER REGULATORS</li> <li>8. CPU 2, CPU 3, AND NMI BUS WINDOW (NBW).</li> <li>9. CPU 0, CPU 1, CONSOLE INTERFACE (CIM) AND CLOCK (PCLK).</li> <li>10. 880 POWER CONTROLLER</li> <li>11. SST BOX</li> </ul> |
|---|--|

TTB-0258

Figure 1-2 VAX 8820/8830/8840 System Cabinet Layout (Front)

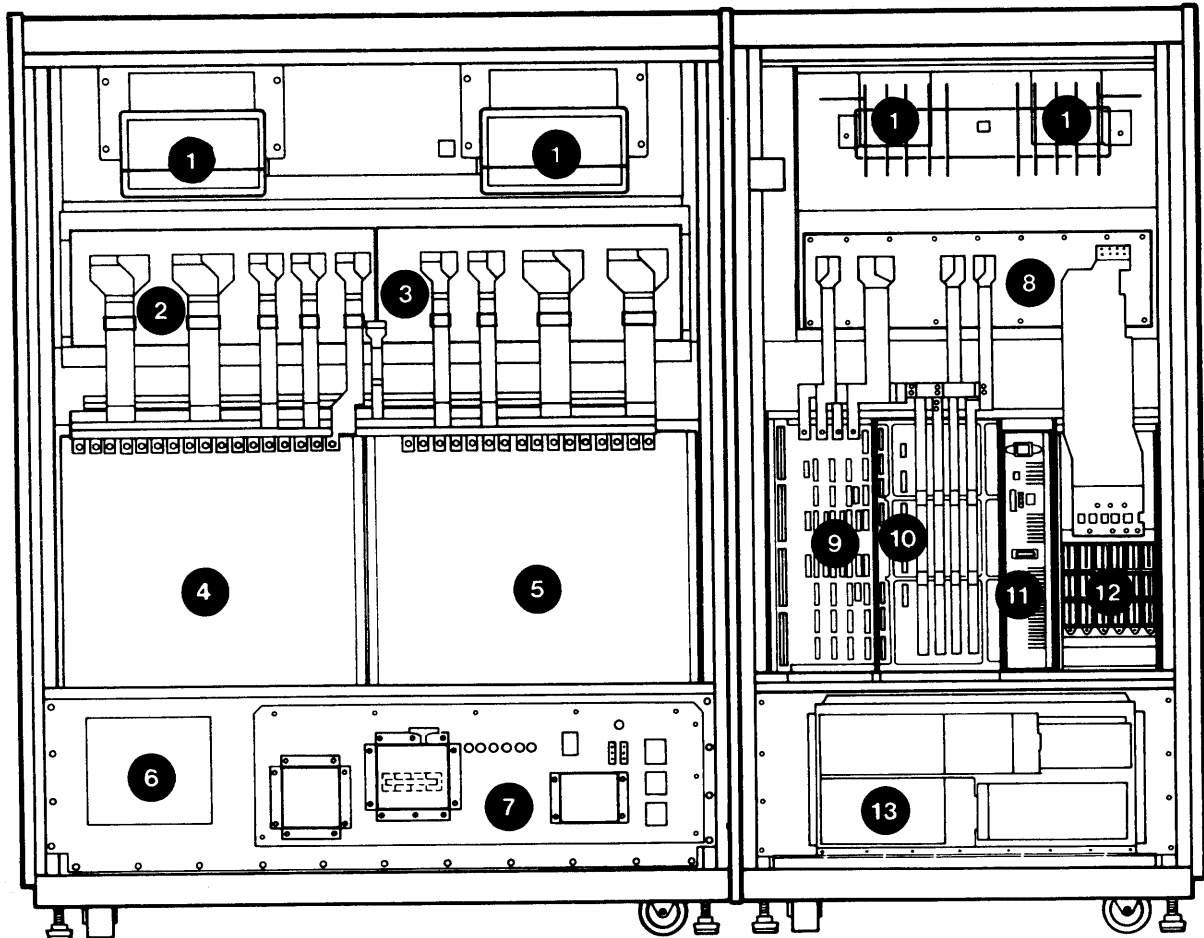

CPU CABINET

MEMORY CABINET

REAR VIEW

- |  |   |
|--|---|
| 1. AIR MOVER DEVICE (BLOWER)                                     | 8. MPS BACKPLANE 3  |
| 2. MPS BACKPLANE 1   | 9. NMI BUS WINDOW (NBW),<br>MEMORY CONTROLLER (PMCL),<br>AND VAXBI INTERFACE (UP TO<br>3 PBIA MODULES). |
| 3. MPS BACKPLANE 2   | 10. MEMORY ARRAY MODULES  |
| 4. CPU 0, CPU 1, CONSOLE<br>INTERFACE (CIM) AND<br>CLOCK (PCLK). | 11. BATTERY BACKUP UNIT   |
| 5. CPU 2, CPU 3, AND NMI<br>BUS WINDOW (NBW).                    | 12. VAXBI   |
| 6. SST BOX   | 13. PBOX (3 CSP MODULES AND<br>1 ILM MODULE).   |
| 7. 880 POWER CONTROLLER  |   |

TTB-0259

Figure 1-3 VAX 8820/8830/8840 System Cabinet Layout (Back)

## INTRODUCTION

**Table 1-4 VAX 8820/8830/8840 System Physical Characteristics**

| Characteristic               | Parameters  |                                    |  |
|------------------------------|---|------------------------------------|--|
| <b>Dimensions</b>            | <b>CPU Cabinet<br/>H9650 DWHB (4<br/>CPUs)</b>  | <b>Memory Cabinet<br/>H9654-EA</b> | <b>VAXBI Expansion Cabinet<br/>H9654-EC/ED</b> |
| Height                       | 152 cm (60 in)  | 152 cm (60 in)                     | 152 cm (60 in)                                 |
| Width                        | 118 cm (46.5 in)  | 76 cm (30 in)                      | 76 cm (30 in)                                  |
| Depth                        | 76 cm (30 in)   | 76 cm (30 in)                      | 76 cm (30 in)                                  |
| <b>Weight</b>                |   |                                    |  |
| 50 Hz                        | 487 kg (1074 lb)  | 305 kg (673 lb)                    | 308 kg (680 lb)                                |
| 60 Hz                        | 487 kg (1074 lb)  | 305 kg (673 lb)                    | 245 kg (540 lb)                                |
| <b>Environmental</b>         |   |                                    |  |
| Heat Dissipation:            | VAX 8840 system - 37.3k BTU/hr<br>VAX 8830 system - 31.9k BTU/hr<br>VAX 8820 system - 26.6k BTU/hr<br>VAXBI Expander cab. - 6.5K BTU/hr   |                                    |  |
| Maximum<br>Temperature Rise: | 3°C/hr (5.5°F/hr)   |                                    |  |
| Temperature<br>Range:        | Operational - 15°-32°C (59°-90°F)<br>Non-operational - -40°-66°C (-40°-151°F)   |                                    |  |
| Humidity:                    | Operational - 20-80 % RH (non-condensing)<br>Non-operational - 10-95 % RH (non-condensing)  |                                    |  |
| Cooling system:              | Type - Air-moving device<br>Air Source - Filtered ambient air<br>Drive - Three-phase, 208 V ac, 60Hz; 460 V ac, 50Hz; induction motor<br>Air Mover - Quad-inlet, dual-outlet centrifugal blower |                                    |  |

**Table 1-4 (Cont.) VAX 8820/8830/8840 System Physical Characteristics**

| Characteristic             | Parameters   |
|----------------------------|--|
| <b>Electrical</b>          |  |
| Maximum Power Consumption: | 12.6 kW  |
| Input Requirements:        | Voltage:<br>60 Hz - Three-phase 208 V ac (180-222 V rms)<br>50 Hz - Three-phase 380 V ac (331-407 V rms)<br>50 Hz - Three-phase 416 V ac (360-443 V rms)<br>Frequency Tolerance:<br>60 Hz +/- 3 Hz<br>50 Hz +/- 3 Hz |

**1.4.1 Enclosures**

The VAX 8820/8830/8840 system is housed in a MicroVAX II pedestal enclosure, an H9650 cabinet, and an H9657 cabinet.

The MicroVAX II pedestal enclosure (system console) contains:

- MicroVAX II processor with 5 Mbyte of memory
- VT320 console (terminal and keyboard)
- Winchester disk with controller
- Removable streamer tape drive and controller
- DZQ11 asynchronous multiplexer (remote console and printer)
- QC module which connects by cable to the H9650 cabinet

The H9650 cabinet, usually called the CPU cabinet, contains:

- Power controller and solid-state transformer box
- Modular power system
- Cooling system
- Module card cage (NMI backplane for 4 CPUs)

The H9657 cabinet, usually called the memory cabinet, contains:

- PBox and modular power system
- Battery Backup Unit
- Module card cage (memory controller, I/O)
- Module card cage (memory arrays)
- Module card cage (6 VAXBI slots)
- Cooling system

Two VAXBI expansion cabinets can be added to the system to house devices and device controllers on up to six VAXBIs.



## CHAPTER 2

# VAX 8820/8830/8840 SYSTEM OPERATION

### 2.1 INTRODUCTION

This chapter covers the VAX 8820/8830/8840 system console and system operation and provides a brief summary of the console commands.

### 2.2 SYSTEM SETUP AND PREPARATION FOR USE

Check that the VAX 8820/8830/8840 system is set up and configured properly. Refer to the following documents:

- *VAX 8820/8830/8840 System Site Planning and Preparation Guide (EK-8840P-SP)*
- *VAX 8820/8830/8840 System Installation Guide (EK-8840I-IN)*
- *VAX 8820/8830/8840 Console User's Guide (AA-FJ84A-ME)*

#### 2.2.1 Input Power

Three amber LEDs on the 880A/B Power Controller panel will be lit when input power is available to the system. There is one LED for each phase: L1, L2, and L3. The location of these LEDs on the panel is indicated in Figure 2-1. Before turning the system power on, check that these three LEDs are lit, indicating that three-phase power is available to the system.

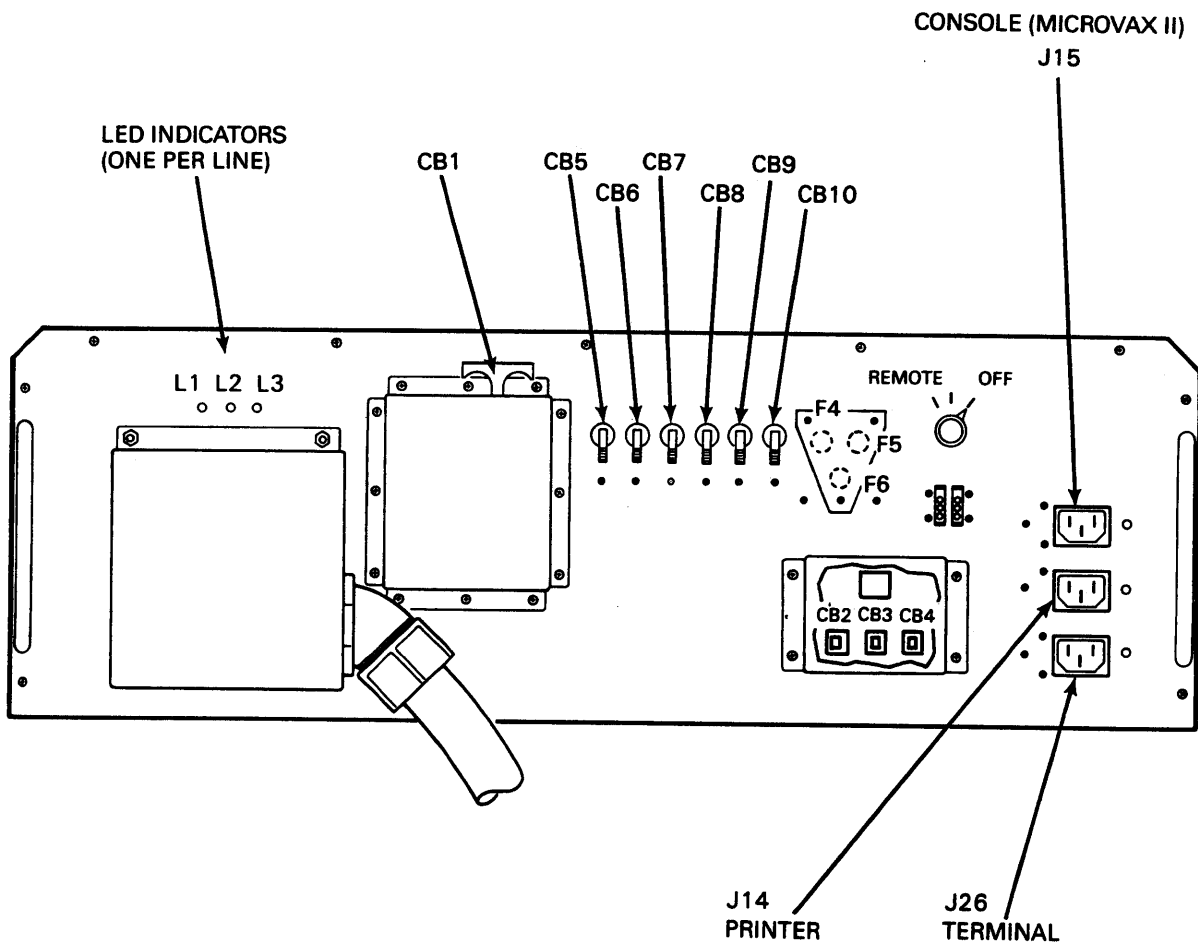

TTB-0260

Figure 2-1 880 A/B Power Controller Panel

### 2.2.2 Primary System Power

Primary power is applied to the VAX 8820/8830/8840 system in three steps:

1. Turn on peripheral power breakers
2. Turn on main power breaker (CB1)
3. Turn on console power

**2.2.2.1 Power Breakers**

The VAX 8820/8830/8840 system has ten circuit breakers as listed in Table 2-1.

**Table 2-1 VAX 8820/8830/8840 System Circuit Breakers**

| <b>Breaker</b> | <b>Voltage</b>        | <b>Unit(s) powered</b>       |
|----------------|-----------------------|------------------------------|
| 1              | 3-phase ac            | L1,L2,L3 to SST box.         |
| 2,3,4          | 1-phase ac (L1,L2,L3) | Dranetz Power Monitor port   |
| 5              | 1-phase ac (L1)       | Console (MicroVAX II )       |
| 6              | 1-phase ac (L2)       | Printer                      |
| 7              | 1-phase ac (L2)       | Local Console Terminal       |
| 8              | 1-phase ac (L1)       | Spare                        |
| 9              | 1-phase ac (L1)       | Spare                        |
| 10             | 1-phase ac (L1)       | PBox and Battery Backup Unit |

The circuit breakers are located on the 880A/B Power Controller panel which is at the lower right side of the rear of the CPU cabinet. The panel is illustrated in Figure 2-1.

Turn the circuit breakers on in two steps:

1. With CB1 in the OFF position, turn circuit breakers 5 through 10 to the ON position. Circuit breakers 2 through 4 are used by qualified field service personnel to connect the Dranetz power monitor to the main system input power; circuit breakers 2 through 4 should be in the OFF position during normal operation.
2. Turn CB1 to the ON position.

**2.2.2.2 Starting the Console Subsystem**

The console subsystem is started in two steps:

1. Turn the power on.
2. Run the console subsystem software.

The console subsystem receives power from the VAX 8820/8830/8840 system cabinet when the main and console circuit breakers (CB1 and CB5) are in the ON position. The console power-on switch shown in Figure 2-2 must be placed in the ON or "1" position to turn on console power.

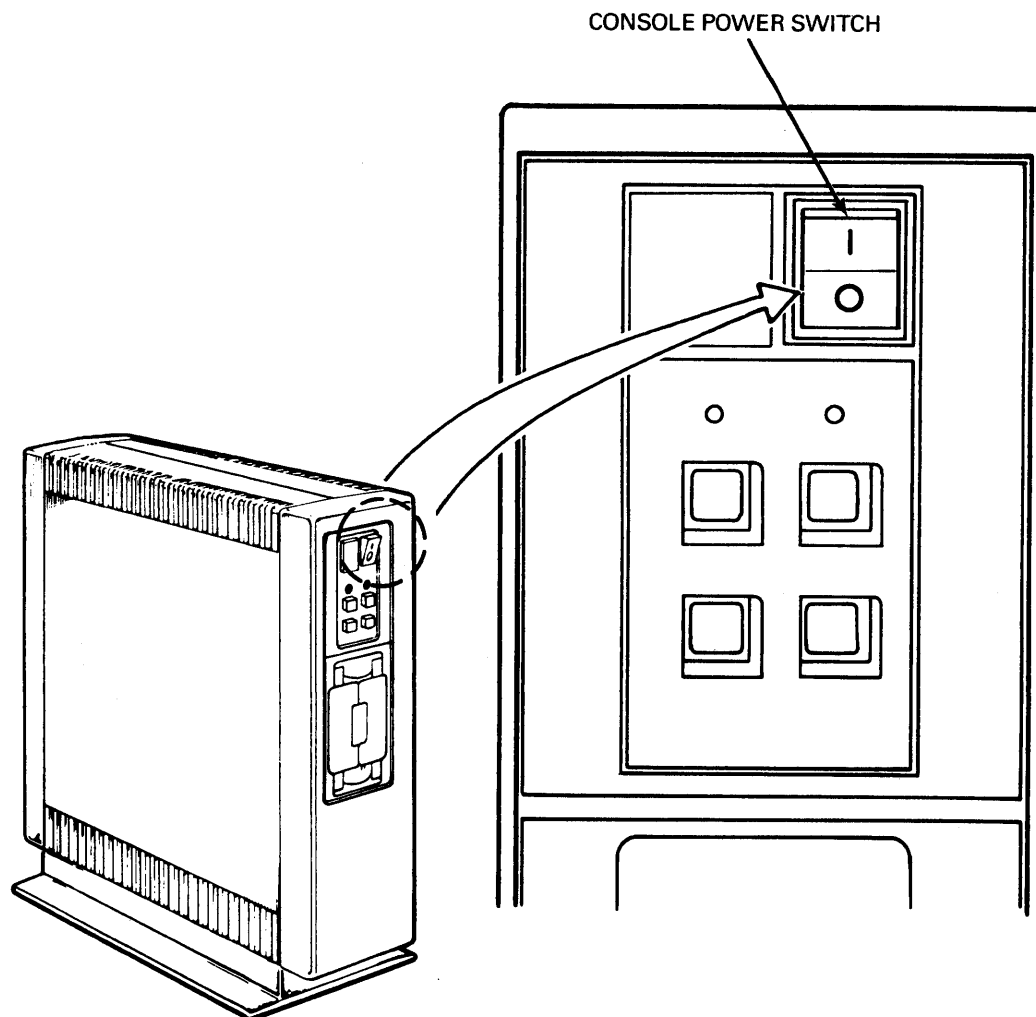

TTB-0261

**Figure 2-2 Location of the Console Power-On Switch**

The console subsystem software is started by the following steps (see Example 2-1):

1. MicroVAX II automatically boots when power is turned on.
2. Operator is logged into VAX/VMS Operating System on MicroVAX II.
3. The POLARIS program runs @VERIFY to check power status.
4. The POLARIS program displays the local console prompt: PS-OFF>.

KA630-A.V1.3

Performing normal system tests.

7..6..5..4..3..

Tests completed.

Loading system software.

2..1..0..

MicroVMS Version V4.5 3-Sep-1986 20:00

The Console system is now executing the startup procedure.

Define System Logical Names...

Starting DECnet...

%RUN-S-PROC\_ID, identification of created process is 00000025

%RUN-S-PROC\_ID, identification of created process is 00000027

Starting QFueue Manager...

Starting Batch Queue...

Misc Installs...

Job START\_CONSOLE (queue SYS\$BATCH, entry 13) started on SYS\$BATCH

%SET-I-INTSET, login interactive limit = 64, current interactive value=0

VAX-xxxx

Copyright 1987 Digital Equipment Corporation

POLARIS — VAX-xxxx Console Program — Version 0.1240

Sunday 4-JAN-1987 15:34:24.72 OPA0

VAX-xxx Console EMM Subprocess — Version 0.155

VAX-xxx Console Printer Subprocess — Version 0.31

%Console Auto Startup Enabled

\*\*\*\*\*

<Remote Console enabled>

\*\*\*\*\*

%EMM-I-POWER\_OFF, System Power is Off

The Current Date and Time is Sunday 4-JAN-1987 15:34:42.67

%EMM-I-POWER\_OFF, System Power is Off

% Command file aborted at line 20

PS-OFF>

TTB-0367

**Example 2-1 Console Display of Console Subsystem Startup**

**WARNING**

**High voltage and power is present in the VAX 8820/8830/8840 system. If for any reason there is a need to open the cabinets, be sure to remove power from the system. Only qualified field service personnel should open or enter the system cabinets. Consult with the system manager before powering down the system.**

**2.2.3.1 Power On**

The power-on sequence is initiated by entering the POWER ON command at the console terminal. This command turns on the solid-state transformer (generates 300 V dc) and air movers 1 and 2:

**PS-OFF>POWER ON**

The power-on sequence can also be initiated by a VAX 8820/8830/8840 system powerfail recovery. The console software determines if the software is recovering from a "console only" power failure. It determines this by examining the VAX power status via the environmental monitoring module in the power system.

The power-up procedure requires that the console send commands to the EMM units to apply system power in a particular sequence. Table 2-2 shows the sequence in which the power supply modules are activated. Figure 2-3 illustrates the MPS unit letter identification code.

EMM CONTROL LETTER DESIGNATION

| MOD<br>E1 | MOD<br>E1 | MOD<br>D1 | MOD<br>D1 | EMM<br>1 | MOD<br>C1 | MOD<br>D1 | MOD<br>D1 | MOD<br>E1 | MOD<br>E1 |
|-----------|-----------|-----------|-----------|----------|-----------|-----------|-----------|-----------|-----------|
| H7180     | H7180     | H7187     | H7187     | H7188    | H7186     | H7187     | H7187     | H7180     | H7180     |
| -5.2 V    | -5.2 V    | -2.0 V    | -2.0 V    | EMM      | +5.0 V    | -2.0 V    | -2.0 V    | -5.2 V    | -5.2 V    |

CPU CARD CAGE (FRONT VIEW)

EMM CONTROL LETTER DESIGNATION

| MOD<br>F2 | EMM<br>2 | MOD<br>B2 | MOD<br>C2 | MOD<br>E2 | MOD<br>D2 |
|-----------|----------|-----------|-----------|-----------|-----------|
| H7189     | H7188    | H7186     | H7186     | H7180     | H7187     |
| BI        | EMM      | +5.0 V    | +5.0 V    | -5.2 V    | -2.0 V    |

MEMORY/IO CARD CAGE (FRONT VIEW)

TTB-0262

Figure 2-3 MPS Unit Letter Identification

**Table 2-2 Module Power Supply Turn on Sequence**

| <b>Order</b> | <b>Module</b> | <b>Power Application</b>                      |
|--------------|---------------|---|
| 1            | J             | +300 V to 4 MPS cardcage 300 V buses          |
| 2            | B2            | +5.0 V to memory                              |
| 3            | C2,C1         | +5.0 V to NMI devices (CPU & memory)          |
| 4            | F2            | +5.0 V, +12 V, -12 V, -5.2 V, -2.0 V to VAXBI |
| 5            | E1,E2         | -5.2 V to NMI devices (CPU & memory)          |
| 6            | D1,D2         | -2.0 V to NMI devices (CPU & memory)          |

**2.2.3.2 System Initialization**

After secondary power has been turned on, the system may be initialized by entering @SYSINIT on the console:

```
PS-HW-0>@SYSINIT
```

This verifies and initializes the system, and loads the VAX 8820/8830/8840 system microcode. The SYSINIT.COMD command file is shown in Example 2-2.

```
!+
! SYSINIT.COMD - For a VAX xxxx system
! REV 1.0
!
! This SYSINIT.COMD has been specifically tailored
! for interactive command use.
! We suggest that you do not edit this file unless
! you wish to load USER WCS.
!-
!-----
DISABLE ERROR                ! If error, abort
CLEAR RESTART__FLAGS        ! Always allow booting
CONSOLE                      ! Set command level
SET DEFAULT HEX              ! Set up logging
SET TERMINAL LOCAL
SHOW TIME                    ! Put time stamp in logfile
!
POWER STATUS                 ! Display current power state
!
IF NOT POWER__ON THEN ABORT

                                ! If power is not on exit
                                ! system initialization procedure.

!
INITIALIZE/HARDWARE          ! Init to base hardware level
SET CLOCK NORMAL             ! Set clock period
!
VERIFY MODULE__PLACEMENT    ! See if any CPUs are there
    IF NOT STATUS THEN ABORT ! If no CPUs, quit.
!
SELECT CPU ALL               ! For whatever CPUs are there, ...
!
SENSE REVISION CPU          ! Read CPU board revisions
!+
! Power up diagnostics are in the command file POWERUP.COMD
! located in directory [PSTAR]. To inhibit power up diagnostics
! ENABLE QUICK__BOOT.
IF NOT QUICK__BOOT THEN @[PSTAR]POWERUP.COMD
```

TTB-0263

**Example 2-2 (Cont.) SYSINIT.COMD Command File**

```

!-
CONSOLE
SET CLOCK ON
INITIALIZE/KNOWN-STATE           ! Put all cpus in known state
SELECT CPU ALL                    ! Reset CPU selection
LOAD WCS/CPU ALL UCODE.BIN       ! Load ISP microcode,
    IF NOT STATUS THEN ABORT     ! Exit if any error is encountered
LOAD CACHECONROL/CPU ALL CCODE.BIN ! Cache microcode,
    IF NOT STATUS THEN ABORT     ! Exit if any error is encountered
LOAD IBDECODER/CPU ALL DRAM.BIN  ! IBOX decoder tables.
    IF NOT STATUS THEN ABORT     ! Exit if any error is encountered
SET CLOCK OFF                    ! Stop clocks to start microcode
START/WCS/CPU ALL CSM-INIT       ! Start the CPUs!
    IF NOT STATUS THEN ABORT     ! Exit if something went wrong
!
LOAD SDF/CPU ALL SDFDEF.BIN      ! Load microcode constants
    IF NOT STATUS THEN ABORT     !
!+
! Remove the comment flags on the following lines
! if you are loading user WCS
!
! LOAD UWCS/CPU ALL USERWCS.BIN  ! Must come after SDF is loaded
! SET CLOCK OFF                  ! Clocks off to start microcode
! START/WCS/CPU ALL CSM-INIT     ! Restart microcode with user WCS
!     IF NOT STATUS THEN ABORT   !
!
!-
INITIALIZE/CPU/CPU ALL           ! Initialize hardware states & VAX regs
    IF NOT STATUS THEN ABORT
disable error
INITIALIZE/IO                    ! Reset I/O devices
INITIALIZE/NBI                   ! Initialize NBIs
SENSE REVISION MCL               ! Read memory controller revision
SENSE REVISION NBI              ! Read NBI adapter revision
REVISION/COMPARE                 ! Verify revisions
REVISION/SAVE                    ! Save present revisions
write nbw1fsr 2000               ! clear interlock busy
read nbw1clr                     ! clear interrupts
write nbw0fsr 2000               ! clear interlock busy
read nbw0clr                     ! clear interrupts
read memcsr5                     ! clear nmi fault
!
INITIALIZE/CPU/CPU ALL           ! Load SID and rev IPRs
    IF NOT STATUS THEN ABORT

```

TTB-0264

**Example 2-2 (Cont.) SYSINIT.COMD Command File**

```

!+
! Before memory can be initialized, a memory configuration file
! must have been created.
! This command will create the file memconfig.dat if it doesn't exist.
!-
INITIALIZE/MEMORY/CLEAR           ! Write 0's to all of memory
!+
! Initialize halt code on each CPU
!-
SET CPU 0
if cpu__available then DEPOSIT SDF OCA 3   ! Powerfailure halt code
SET CPU 1
if cpu__available then DEPOSIT SDF OCA 3   ! Powerfailure halt code
SET CPU 2
if cpu__available then DEPOSIT SDF OCA 3   ! Powerfailure halt code
SET CPU 3
if cpu__available then DEPOSIT SDF OCA 3   ! Powerfailure halt code
!+
! Attempt to restart or boot the primary
!-
SET CPU PRIMARY                   ! Single-cpu operations from here on
CONSOLE/SAVE                       ! Save console status
CLEAR RESTART-FLAGS               ! Clears WARM and COLD restart flags
!
!End of SYSINIT.CMD
show el 1
disable echo

```

TTB-0265

**Example 2-2 (Cont.) SYSINIT.CMD Command File**

### 2.2.3.3 System Boot

After secondary power has been applied, the system may be booted (VAX/VMS Operating System loaded and started). The boot sequence can be initiated using the default file DEFBOO.CMD or from a particular command file such as BCIBOO.CMD or BDABOO.CMD. Samples of these three files are shown in Example 2-3, Example 2-4, and Example 2-5.

The command file DEFBOO.CMD, used to boot the VAX/VMS operating system from the console storage device, is shown in Example 2-3. Use the command:

PS-CIO-0>BOOT

```
! DEFBOO.CMD - Default Boot Command file
! Rev Num 1.0
!
! This command procedure will be executed automatically during system
! initialization or following a power failure or an error halt if you
! have enabled the AUTO__BOOT keyswitch. It will also be executed when
! the command BOOT is entered.
!
! Boot DDDnnn/R5+##
!
! Replace DDDnnn with the name of the boot command procedure that you
! wish to execute.
!   DDD  device name: BCI, BDA
!   nnn  boot device unit number

BOOT BCI/R5=1
```

TTB-0266

### Example 2-3 DEFBOO.CMD Command File

```

BCIBOO.CMD
! REV 1.0
!
! Command procedure to BOOT the VAX/VMS Operating System from
! an HSC over the BCI.
!
! The following register deposits must be done before executing
! this command procedure or must be edited to correspond to the
! hardware configuration:
! R1 - Bus address information
! R2 - CI port # of HSC(s) to which drive is ported
! R3 - device unit number
CLEAR DEBUG
SET TERMINAL LOCAL                !Set up logging
SET DEFAULT HEXADECIMAL
SET CPU PRIMARY                    !Select CPU that will be the primary
IF NOT HALTED THEN HALT           !Halt it and avoid warning messages
EXAMINE SDF OCA                    !Retrieve halt code
DEPOSIT AP @                       !Move halt code to AP
INITIALIZE/CPU/cpu=all            !Initialize CPU
INITIALIZE/MEMORY/clear          !Init memory
INITIALIZE/IO                     !Clear BI errors, NMI and BI node state info
DEPOSIT PHY/L 3E000000 020F00F0   !Clear interlock timeout in mem CSRO
EXAMINE PHY/L 3E000010            !Read mem CSR4 (clears interrupts)
EXAMINE PHY/L 3E000014            !Read mem CSR5 (clears NMI fault)
DEPOSIT PHY/L 3E000008 F0000000   !Clear RDS error bits in mem CSRO
DEPOSIT PHY/L 3A000000 2000       !Clear interlock busy in NBW1FSR
EXAMINE PHY/L 3A000808            !Read NBW1CLR (clears interrupts)
DEPOSIT PHY/L 38000000 2000       !Clear interlock busy in NBW0FSR
EXAMINE PHY/L 38000808            !Read NBW0CLR (clears interrupts)
EXAMINE PHY/L 3E000014            !Read mem CSR5 (clears NMI fault)
DEPOSIT R0 %x20                   !CI boot device type code
DEPOSIT R1 %x02                   !Boot dev bus adr: <3:0>=BI node #,<5:4>=BI
#
DEPOSIT R2 %x03                   !CI port # of HSC: <7:0>=CI port # of HSC,
!<15:8>=CI port # of 2nd HSC if dual ported
DEPOSIT R3 %d193                  !Unit # of drive, decimal radix
DEPOSIT R4 0                      !Not applicable
DEPOSIT R5 %x01                   !Software boot control flags and
!root directory # in <31:28>. Defaults
!to SYS0 or unrooted directory
!Override above if given in boot cmd
!Display disk number

IF P1 THEN DEPOSIT R3 %P1
IF P2 THEN DEPOSIT R5 %P2
EXAMINE R3
EXAMINE R5
FIND/MEM                          !Display R5 parameter
IF NOT STATUS THEN ABORT          !Find 64kb of memory, set cold start bit
EXAMINE SP                         !Boot if find was successful
LOAD/START @ VMB.EXE              !Show address of working memory + %X200
EXAMINE SP                         !Load VMB into good mem + %X200
START @                            !patch vmb
                                    !Start executing VMB

```

TTB-0267

**Example 2-4 BCIBOO.CMD Command File**

```

!ENABLE ECHO
! BDABOO.CMD
! REV 1.0
!
! Command procedure to BOOT VMS from a BDA disk.
!
! NEXT_PRIMARY is expected to point to the CPU that is to be used
! as the primary CPU.
!
! The following register deposits must be done before executing this
! command procedure or must be edited to correspond to the hardware
! configuration:
! R1 - Bus address information
! R2 - <31:24> = optional controller letter specifier, remaining bits
!       depend on device type in R0
! R3 - device unit number
!
CLEAR DEBUG
SET TERMINAL LOCAL                ! Set up logging
SET DEFAULT HEXADECIMAL
SET CPU PRIMARY                    ! Select CPU that will be the primary
IF NOT HALTED THEN HALT           ! Halt it and avoid unnecessary warning messages
EXAMINE SDF OCA                    ! Retrieve halt code
DEPOSIT AP @                       ! Move halt code to AP
INITIALIZE/CPU/CPU=ALL            ! Init CPUs, copy next_primary to current
INITIALIZE/MEMORY/clear          ! Init Memory
INIT/IO                            ! Clear BI errors and nmi and BI node state info
DEPOSIT PHY/I 3E000000 020F00F0   ! Clear interlock timeout in mem CSRO
EXAMINE PHY/I 3E000010            ! Read mem CSR4 (clears interrupts)
EXAMINE PHY/I 3E000014            ! Read mem CSR5 (clears nmi fault)
DEPOSIT PHY/I 3E000008 F0000000   ! Clear RDS error bits in mem CSRO
DEPOSIT PHY/L 3A000000 2000       ! Clear interlock busy in NBW1FSR
EXAMINE PHY/L 3A000808            ! Read NBW1CLR (clears interrupts)
DEPOSIT PHY/L 38000000 2000       ! Clear interlock busy in NBW0FSR
EXAMINE PHY/L 38000808            ! Read NBW0CLR (clears interrupts)
EXAMINE PHY/L 3E000014            ! Read mem CSR5 (clears NMI fault)
DEPOSIT R0 %x21                   ! BDA boot device type code
DEPOSIT R1 %x15                   ! Boot dev bus adr:<3:0>=BI node #,<6:4>=BI
!DEPOSIT R1 %x44                  ! Boot dev bus adr:<3:0>=BI node #,<6:4>=BI #
DEPOSIT R2 0                       ! <31:24>=optional controller letter specifier
DEPOSIT R3 %d100                   ! Unit # of drive, decimal radix
DEPOSIT R4 0                       ! Not applicable
DEPOSIT R5 %x81                   ! Software boot control flags and
! root directory @ in <31:28>. Defaults
! to sys0 or unrooted directory
! R5: %x81 - don't test mem,sysboot
! R5: %x87 - don't test mem,sysboot,breakpoints
! R5: %xA7 - don't test mem,sysboot,all break
! R5: %x1 - sysboot
! R5: %x0 - normal

```

TTB-0268

**Example 2-5 BDABOO.CMD Command File**

```

IF P1 THEN DEPOSIT R3 %P1
IF P2 THEN DEPOSIT R5 %P2
EXAMINE R3
EXAMINE R5
FIND/MEM
IF NOT STATUS THEN ABORT
EXAMINE SP
LOAD /START=@ VMB.EXE
!
!examine phy/1 3e94
!deposit . 00400011
EXAMINE SP
!
START @
! override above if given in boot cmd
! "
! Display disk number
! Display R5 parameter
! Find 64kb of memory; set cold start bit
! Boot if find was successful
! Show address of working memory + %X200
! Load VMB into good mem + %X200
!patch vmb
!patch vmb
!patch vmb
! Start executing VMB

```

TTB-0289

**Example 2-5 (Cont.) BDABOO.CMD Command File**

**2.2.3.4 System Initialization and Autoboot**

The automatic startup procedures initialize the system and then automatically boot the system using the command file AUTO\_SYSINIT.CMD. The command file is shown in Example 2-6.

```

!+
! AUTO__SYSINIT.CMD - For a VAX xxxx system
! REV 1.0
!
! This SYSINIT.CMD has been specifically tailored
! for automatic startup operation.
! We suggest that you do not edit this file unless
! you wish to load USER WCS.
!-
!-----
DISABLE ERROR                ! If error, abort
CONSOLE                      ! Set command level
SET TERMINAL LOCAL          ! Set up logging
SHOW TIME                   ! Put time stamp in logfile
!                           ! Display current power state
POWER STATUS
!
IF POWER__ON THEN GOTO 100
IF NOT AUTO__POWERON THEN ABORT

! If power is not on and
! AUTO__POWERON keyswitch not enabled
! exit system initialization procedure.

!
DTEXT "**** Turning ON System Power ****"
POWER ON                    ! keyswitch is enabled, turn on power.
    IF NOT STATUS THEN ABORT ! Abort if POWER ON failed
                                ! If power is not on and AUTO__POWERON

100:
!
SET DEFAULT HEX
INITIALIZE/HARDWARE        ! Init to base hardware level
SET CLOCK NORMAL          ! Set clock period
!
VERIFY MODULE-PLACEMENT   ! See if any CPUs are there
    IF NOT STATUS THEN ABORT ! If no CPUs, quit.
!
SELECT CPU ALL            ! For whatever CPUs are there, ...
set primary 0
set next_primary 0
set cpu 0
if cpu_available then goto 100
set primary 1
set next_primary 1
set cpu 1
if cpu_available then goto 100
set primary 2
set next_primary 2
set cpu 2
if cpu_available then goto 100
set primary 3
set next_primary 3
set cpu 2
if cpu_available then goto 100
set primary 3
set next_primary 3
set cpu 2
if cpu_available then goto 100
dtext "**** No CPUs Available ****"
abort
100:
!
SENSE REVISION CPU        ! Read CPU board revisions

```

TTB-0270

**Example 2-6 AUTO\_SYSINIT Command File**

```

!+
! Power up diagnostics are in the command file POWERUP.CMD
! located in directory [PSTAR]. To inhibit power up diagnostics
! ENABLE QUICK-BOOT.
IF NOT QUICK-BOOT THEN @[PSTAR]POWERUP.CMD
!-
CONSOLE
SET CLOCK ON
INITIALIZE/KNOWN-STATE           ! Put all cpus in known state
SELECT CPU ALL                   ! Reset CPU selection
LOAD WCS/CPU=ALL UCODE.BIN       ! Load ISP microcode,
    IF NOT STATUS THEN ABORT     ! Exit if any error is encountered
LOAD CACHECONTROL/CPU=ALL CCODE.BIN ! Cache microcode,
    IF NOT STATUS THEN ABORT     ! Exit if any error is encountered
LOAD IBDECODER/CPU=ALL DRAM.BIN  ! IBOX decoder tables.
    IF NOT STATUS THEN ABORT     ! Exit if any error is encountered
SET CLOCK OFF                   ! Stop clocks to start microcode
START/WCS/CPU=ALL CSM-INIT       ! Start the CPUs!
    IF NOT STATUS THEN ABORT     ! Exit if something went wrong
WAIT/HALT/CPU=ALL               ! Wait for CPUs to HALT
LOAD SDF/CPU=ALL SDFDEF.BIN     ! Load microcode constants
    IF NOT STATUS THEN ABORT     !

!+
! Remove the comment flags on the following lines
! if you are loading user WCS
!
! LOAD UWCS/CPU=ALL USERWCS.BIN  ! Must come after SDF is loaded
! SET CLOCK OFF                  ! Clocks off to start microcode
! START/WCS/CPU=ALL CSM-INIT     ! Restart microcode with user WCS
!     IF NOT STATUS THEN ABORT   !
!
!-
INITIALIZE/CPU/CPU=ALL          ! Initialize hardware states & VAX regs
    IF NOT STATUS THEN ABORT    !
disable error
INITIALIZE/IO                   ! Reset I/O devices
INITIALIZE/NBI                   ! Initialize NBIs
REVISION/COMPARE                 ! Compare revisions
REVISION/SAVE                    ! Save revisions
SENSE REVISION MCL               ! Read memory controller revision
SENSE REVISION NBI              ! Read NBI adapter revision
disable error
write nbw1fsr 2000               ! clear interlock busy
read nbw1clr                     ! clear interrupts
write nbw0fsr 2000               ! clear interlock busy
read nbw0clr                     ! clear interrupts
read memcsr5                     ! clear nmi fault
!
INITIALIZE/CPU/CPU=ALL          ! Load SID and rev IPRs
    IF NOT STATUS THEN ABORT

```

TTB-0271

**Example 2-6 (Cont.) AUTO\_SYSINIT Command File**

```

!+
! Before memory can be initialized, a memory configuration file
! must have been created.
! This command will create the file memconfig.dat if it doesn't exist.
!-
INITIALIZE/MEMORY                                ! Write 0's to all of memory
                                                ! if memory were not backed up

!ç
! Initialize halt code on each CPU
!-
SET CPU 0
if cpu__available then DEPOSIT SDF OCA 3        ! Powerfailure halt code
SET CPU 1                                        ! Powerfailure halt code
if cpu__available then DEPOSIT SDF OCA 3
SET CPU 2                                        ! Powerfailure halt code
if cpu__available then DEPOSIT SDF OCA 3
SET CPU 3                                        ! Powerfailure halt code
if cpu__available then DEPOSIT SDF OCA 3
!ç
! Attempt to restart or boot the primary
!-
SET CPU PRIMARY                                ! single-cpu operations from here on
CONSOLE/SAVE                                   ! Save console status
IF AUTO__RESTART THEN @[PSTAR]RESTAR.CMD      ! Attempt to restart if AUTO__RESTART
                                                ! enabled
IF AUTO__BOOT THEN @[PSTAR]DEFB0000.CMD       ! If AUTO__RESTART disabled, and
                                                ! AUTO__BOOT enabled attempt to boot
                                                ! Otherwise, EXIT.

CLEAR RESTART-FLAGS                            ! Clears WARM and COLD restart flags
!
!End of SYSINIT.CMD
show el 1
disable echo

```

TTB-0272

### Example 2-6 (Cont.) AUTO\_SYSINIT Command File

#### 2.2.3.5 System Power Down

An intentional powerdown is initiated at the console by entering:

```
PS-CIO-0> POWER OFF
```

The MPS power regulators are turned off in the sequence indicated in Table 2-3.

#### WARNING

**The POWER OFF command *does not* eliminate all power from the VAX 8820/8830/8840 system. Primary ac power and some dc power are still present within the system.**

**Table 2-3 Module Power Supply Turn off Sequence**

| Order | Module | Power Application                          |
|-------|--------|--|
| 1     | D1,D2  | -2.0 V to NMI devices (CPU & memory)       |
| 2     | E1,E2  | -5.2 V to NMI devices (CPU & memory)       |
| 3     | F2     | +5.0 V, +12 V, -12 V, -5.2 V, -2.0 V to BI |
| 4     | C2,C1  | +5.0 V to NMI devices (CPU & memory)       |
| 5     | B2     | +5.0 V to memory                           |
| 6     | J      | +300 V to 4 MPS cardcage 300 V buses       |

**2.2.3.6 Powerfail and Standby Modes**

Power failure recognition by the environmental monitoring modules in the power system will result in an interrupt to the VAX 8820/8830/8840 system via the console interface. The EMM units will be directed to shut off the MPS power units in the sequence indicated in Table 2-4. This action can also be initiated by the operator at the system console by entering:

```
PS-CIO-0>POWER STANDBY
```

**Table 2-4 Power Fail and Standby Modes MPS Turn Off Sequence**

| Order | Module | Power Application                          |
|-------|--------|--|
| 1     | D1,D2  | -2.0 V to NMI devices (CPU & memory)       |
| 2     | E1,E2  | -5.2 V to NMI devices (CPU & memory)       |
| 3     | F2     | +5.0 V, +12 V, -12 V, -5.2 V, -2.0 V to BI |
| 4     | C2,C1  | +5.0 V to NMI devices (CPU & memory)       |

**WARNING**

**The POWER STANDBY and powerfail modes do not eliminate all power from the VAX 8820/8830/8840 system. Primary ac power and some dc power are still present within the system, as well as backup power in backup mode and standby power in standby mode.**

When the system is in STANDBY or powerfail mode, power is present within the system. In STANDBY mode the J regulator is active and supplies 300 V dc to the four MPS 300 V dc buses, and the B2 regulator module (+5.0 Vdc) is active. In powerfail mode the system BBU unit is active and supplies 300 V dc to the four MPS 300 V dc buses, and the B2 regulator module (+5.0 V dc) is active.

### 2.2.3.7 Warm Restart

A warm restart uses the same procedures as the power-on sequence for turning on the system power. The SYSINIT.CMD file exits to the restart command file RESTAR.CMD. A restart parameter block (RPB) must be available for a warm restart, since an intact RPB indicates that memory data is valid. If a warm restart is not possible, the VAX 8820/8830/8840 system executes the default boot command file DEFBOO.CMD. Example 2-7 shows the RESTAR.CMD file.

```

! RESTAR.CMD - For a VAX xxxx System
! REV 1.0
!
!This command file is invoked after a HALT, if a reboot has not been
!requested by the VAX, and after power failure recovery if AUTO__RESTART
!is enabled.
!
!The following tests are required:
!
IF NOT AUTO__RESTART THEN IF AUTO__BOOT THEN @ETAR°FBOO
! Execute defboo if
! auto__restart is not enabled but auto__boot is.
IF NOT AUTO__RESTART THEN abort
! if neither auto__restart nor auto__boot are
! enabled then remain halted
! Set up logging
!
SET TERMINAL local
SET DEFAULT HEXADECIMAL
!
!
EXAMINE SDF OCA ! Retrieve HALT code
DEPOSIT AP @ ! Put halt code into the AP
EXAMINE PC ! Retrieve old PC
DEPOSIT R10 @ ! Put old PC into R10
EXAMINE PSL ! Retrieve old PSL
DEPOSIT R11 @ ! Put old PSL into R11
INITIALIZE/cpu ! Initialize processor.
EXAMINE AP
DEPOSIT SDF OCA @
DEPOSIT R0 0 ! Clear unused register.
DEPOSIT R1 0 ! Clear unused register.
DEPOSIT R2 0 ! Clear unused register.
DEPOSIT R3 0 ! Clear unused register.
DEPOSIT R4 0
! Clear unused register. DEPOSIT
R5 0 ! Clear unused register.
enable error
FIND/RPB ! Locate restart parameter block and put addr + 200
! in SP and contents of RPB+4 into PC
IF NOT STATUS THEN IF AUTO__BOOT THEN @[PSTAR]DEFBOO
! If an RPB was not found and
! auto__boot is enabled go try to reboot
IF NOT STATUS THEN abort
! If an RPB was not found and auto__boot is
! Disabled then remain halted
! Get start address
disable error
EXAMINE PC
START @ ! go

```

TTB-0273

**Example 2-7 RESTAR.CMD Command File**

### 2.3 OPERATOR/CONSOLE INTERACTION

The console, a MicroVAX II system (in the pedestal configuration), is used to initialize, operate, and shut down the VAX 8820/8830/8840 system. The console prompts and commonly used command language statements are described in this section.

#### 2.3.1 Console Command Language Display Prompts

Table 2-5 describes Console Command Language prompts that may appear on the local and remote display screens.

**Table 2-5 Console Command Language Prompts**

| Prompt    | Description  |
|-----------|--|
| >>>       | MicroVAX II power is on and MicroVAX II self-tests have been completed. The MicroVAX II system is booted from this prompt.                     |
| PS>       | Indicates that access to the VAX 8820/8830/8840 system hardware has not been attempted yet.  |
| PS-OFF>   | Indicates that the EMM and the QC module have been verified, but that system power is turned off.  |
| PS-HW-n>  | Indicates that system power is on and that the console connected CPU is number n.  |
| PS-CIO-n> | The system console is in console I/O mode with Console Support Microcode (CSM) loaded into the connected CPU which is number n.                |
| PS-OS-n>  | The console has returned to console I/O mode from console program mode because a CTRL P was typed at the terminal. CPU n is the connected CPU. |

#### 2.3.2 Console Commands

The Console Command Language (CCL) is the interface between the operator and the control and monitoring capabilities of the console subsystem. Table 2-6 provides a short list of frequently-used console commands. Refer to the *VAX 8820/8830/8840 Console User's Guide (AA-FJ84A-ME)* for a detailed description of all console commands.

Table 2-6 Frequently Used Console Commands

| Command              | Description  |             |               |              |              |              |      |       |     |         |             |
|----------------------|--|-------------|---------------|--------------|--------------|--------------|------|-------|-----|---------|-------------|
| @file_spec           | Opens a specified file and processes the records within the file as commands. (The default file extension is .CMD.)  |             |               |              |              |              |      |       |     |         |             |
| BOOT [ device_name ] | Executes the command file device_nameBOO.CMD. If no device name is specified, the file DEFBOO.CMD is used.   |             |               |              |              |              |      |       |     |         |             |
| CLEAR item           | <p>item can be any one of the following:</p> <table> <tr> <td>ACCUMULATOR</td> <td>RESTART_FLAGS</td> </tr> <tr> <td>SCREEN</td> <td>SOMM</td> </tr> <tr> <td>SWITCHES</td> <td>TOMM</td> </tr> </table>   | ACCUMULATOR | RESTART_FLAGS | SCREEN       | SOMM         | SWITCHES     | TOMM |       |     |         |             |
| ACCUMULATOR          | RESTART_FLAGS  |             |               |              |              |              |      |       |     |         |             |
| SCREEN               | SOMM   |             |               |              |              |              |      |       |     |         |             |
| SWITCHES             | TOMM   |             |               |              |              |              |      |       |     |         |             |
| CONSOLE              | Returns the console to top command level from a subcommand level such as DIAG or EMM. This command always returns to or stays at the top command level to avoid an inadvertent exit from the console program.  |             |               |              |              |              |      |       |     |         |             |
| CONTINUE             | <p>In console mode, CONTINUE starts macrocode execution at the address currently present in the macro program counter (PC). Processor initialization is not performed. The processor state is changed from HALTED to RUNNING.</p> <p>In diagnostic mode, CONTINUE continues the execution of the diagnostic that just halted on error, or was interrupted by CTRL/C. Execution will resume at the point at which it was stopped.</p>                           |             |               |              |              |              |      |       |     |         |             |
| DEPOSIT location     | Replaces the contents of a specified location. If no data size or address space qualifiers are specified, the defaults will be those used in the most recent EXAMINE, DEPOSIT or SET DEFAULT command. Initially the defaults are PHYSICAL, LONGWORD, and address 0. If no address is specified, "+" is assumed.  |             |               |              |              |              |      |       |     |         |             |
| DIAGNOSE             | Causes the console to enter the Diagnostic Support mode. The CONSOLE or EXIT commands will return to console mode.   |             |               |              |              |              |      |       |     |         |             |
| DISABLE item         | <p>Establishes console parameters that are retained across power failures, restarts, and reboots. The parameters established by DISABLE are changed by the ENABLE command. Item can be:</p> <table> <tr> <td>AUTO BOOT</td> <td>AUTO POWERON</td> </tr> <tr> <td>AUTO RESTART</td> <td>CONFIRMATION</td> </tr> <tr> <td>CPU cpu_list</td> <td>ECHO</td> </tr> <tr> <td>ERROR</td> <td>LOG</td> </tr> <tr> <td>PRINTER</td> <td>TEXT_OUTPUT</td> </tr> </table> | AUTO BOOT   | AUTO POWERON  | AUTO RESTART | CONFIRMATION | CPU cpu_list | ECHO | ERROR | LOG | PRINTER | TEXT_OUTPUT |
| AUTO BOOT            | AUTO POWERON   |             |               |              |              |              |      |       |     |         |             |
| AUTO RESTART         | CONFIRMATION   |             |               |              |              |              |      |       |     |         |             |
| CPU cpu_list         | ECHO   |             |               |              |              |              |      |       |     |         |             |
| ERROR                | LOG  |             |               |              |              |              |      |       |     |         |             |
| PRINTER              | TEXT_OUTPUT  |             |               |              |              |              |      |       |     |         |             |
| ENABLE item          | Establishes console parameters that are retained across power failures, restarts, and reboots. The parameters established by ENABLE are changed by DISABLE.  |             |               |              |              |              |      |       |     |         |             |

Table 2-6 (Cont.) Frequently Used Console Commands

| Command  | Description  |
|--|--|
| EXAMINE location   | Examines the contents of a specified location. If no data size or address space qualifiers are specified, the defaults will be those used in the most recent EXAMINE, DEPOSIT, or SET DEFAULT command. Initially the defaults are PHYSICAL, LONGWORD, and address 0. If no address is specified, "+" is assumed.   |
| EXIT   | Terminates the current subprogram and returns control to the console program. In EMM or diagnostic mode, returns to CONSOLE mode.  |
| FIND [/CPU:cpu] [/MEMORY] [/RPB]   | The console will look for good memory or a restart parameter block for the indicated CPU. The defaults items are the connected processor and the restart parameter block.  |
| FIND /MEMORY   | Requests Console Microcode (CSM) to search main memory starting at address 0 for a page-aligned 64-kbyte block of good memory.   |
| FIND /RPB  | Requests CSM to search physical memory for a valid restart parameter block. The search leaves the contents of memory unchanged.  |
| HALT [CPU:cpu_list]  | Attempts to stop macrocode execution in all of the specified processors, beginning at the next macro instruction boundary. The state of each of these processors changes from RUNNING to HALTED. If a processor is malfunctioning, it may never try to execute the next macro instruction and therefore never halt. The HALT command produces a message reporting which processors are successfully halted and the contents of the PC for each one of them. If a processor is already halted when the HALT command is issued, a warning message is returned. |
| HELP [help_topic]  | Help_topic is a keyword about which to provide help information. This command allows you to display the function, format, arguments, and switches of any console command.  |
| IF   | Allows a command to be conditionally performed. If the condition specified is met, the remainder of the line is performed. If the condition specified is not met the remainder of the line is ignored.   |
| INITIALIZE [/CONSOLE] [/CPU:cpu_list] [/IO] [/MEMORY] [/CREATE_CONFIGURATION_FILE] | Sets the appropriate part of the system to a defined initial state.  |
| LOAD [ filename ]  | In console mode, LOAD loads data into the specified space. The data comes from the file specified. If no optional qualifiers are specified, the command defaults to loading memory starting at physical address 0.<br><br>In diagnostic mode, the specified diagnostic program is loaded into console memory.  |

Table 2-6 (Cont.) Frequently Used Console Commands

| Command   | Description   |
|---|---|
| <b>MICROSTEP</b> [/CPU:cpu_list]<br>[count]                 | Bursts the clock for the specified number of microcycles (one by default), displays the micro-PCs for all affected CPUs, and enters space bar step mode. Pressing the space bar at this prompt causes another single-cycle micro-cycle to be executed and the new micro-PCs to be displayed. Any non-space character exits the space bar step mode and becomes the first character of a new console command line.   |
| <b>NEXT</b> [/CPU:cpu_list] [count]                         | Executes macroinstructions for the specified count (one by default), displays the PC for all affected CPUs, and enters space bar step mode. Pressing the space bar at this prompt causes another macroinstruction to be executed and the new PCs to be displayed. Any non-space character exits the space bar step mode and becomes the first character of a new console command line.  |
| <b>POWER</b> (ON   OFF   STANDBY<br>  INITIALIZE   STATUS ) | <p>Changes the state of the power system by issuing commands to the EMM. The power may be in one of four states:</p> <ol style="list-style-type: none"> <li>1. OFF – All CPU regulators and memory power are turned off.</li> <li>2. ON – All CPU regulators and memory power are turned on. The system can function.</li> <li>3. STANDBY – CPU power is turned off, memory power remains on.</li> <li>4. INITIALIZE – Communication with the power system is established and default parameters loaded.</li> </ol> <p>See Tables 2-2, 2-3, and 2-4 for the sequence in which power goes to the on, off, standby, or powerfail states.</p> <p>STATUS – Report on the current power state.</p> |
| <b>QUIT</b>   | Terminates the console program and returns to the MicroVMS prompt.  |
| <b>REPEAT</b> command                                       | Sets an internal flag indicating that the command line be continuously executed. REPEAT mode is terminated by typing CTL/C.   |
| <b>RUN</b>  | In diagnostic mode, the specified diagnostic program is loaded into Console memory and started.   |
| <b>SET</b>  | <p>Sets parameters for clocks, CPU defaults, EMM power margins, etc.</p> <p>CLOCK – ON, OFF, SLOW, FAST, NORMAL</p> <p>CPU:cpu</p> <p>MARGINS (regulator) [ NORMAL   HIGH   LOW ]</p> <p>SOMM upc_address – loads the micro-pc into the micromatch register.</p> <p>TERMINAL (LOCAL, NOLOG)</p> <p>TOMM upc_address – Loads the micro-pc into the micromatch register.</p>  |

**Table 2-6 (Cont.) Frequently Used Console Commands**

| <b>Command</b>                 | <b>Description</b>  |       |         |     |          |         |         |         |        |       |        |                |                |                |                |                |                |                |                |          |      |
|--------------------------------|---|-------|---------|-----|----------|---------|---------|---------|--------|-------|--------|----------------|----------------|----------------|----------------|----------------|----------------|----------------|----------------|----------|------|
| <b>SHOW</b>                    | <p>Displays information about certain console and system parameters such as:</p> <table border="0"> <tr> <td>CLOCK</td> <td>CONSOLE</td> </tr> <tr> <td>CPU</td> <td>DEFAULTS</td> </tr> <tr> <td>ENABLES</td> <td>LOGGING</td> </tr> <tr> <td>MARGINS</td> <td>MEMORY</td> </tr> <tr> <td>POWER</td> <td>STATUS</td> </tr> <tr> <td>T1_TEMPERATURE</td> <td>T2_TEMPERATURE</td> </tr> <tr> <td>T4_TEMPERATURE</td> <td>T4_TEMPERATURE</td> </tr> <tr> <td>T5_TEMPERATURE</td> <td>T6_TEMPERATURE</td> </tr> <tr> <td>T7_TEMPERATURE</td> <td>T8_TEMPERATURE</td> </tr> <tr> <td>TERMINAL</td> <td>TIME</td> </tr> </table> | CLOCK | CONSOLE | CPU | DEFAULTS | ENABLES | LOGGING | MARGINS | MEMORY | POWER | STATUS | T1_TEMPERATURE | T2_TEMPERATURE | T4_TEMPERATURE | T4_TEMPERATURE | T5_TEMPERATURE | T6_TEMPERATURE | T7_TEMPERATURE | T8_TEMPERATURE | TERMINAL | TIME |
| CLOCK                          | CONSOLE   |       |         |     |          |         |         |         |        |       |        |                |                |                |                |                |                |                |                |          |      |
| CPU                            | DEFAULTS  |       |         |     |          |         |         |         |        |       |        |                |                |                |                |                |                |                |                |          |      |
| ENABLES                        | LOGGING   |       |         |     |          |         |         |         |        |       |        |                |                |                |                |                |                |                |                |          |      |
| MARGINS                        | MEMORY  |       |         |     |          |         |         |         |        |       |        |                |                |                |                |                |                |                |                |          |      |
| POWER                          | STATUS  |       |         |     |          |         |         |         |        |       |        |                |                |                |                |                |                |                |                |          |      |
| T1_TEMPERATURE                 | T2_TEMPERATURE  |       |         |     |          |         |         |         |        |       |        |                |                |                |                |                |                |                |                |          |      |
| T4_TEMPERATURE                 | T4_TEMPERATURE  |       |         |     |          |         |         |         |        |       |        |                |                |                |                |                |                |                |                |          |      |
| T5_TEMPERATURE                 | T6_TEMPERATURE  |       |         |     |          |         |         |         |        |       |        |                |                |                |                |                |                |                |                |          |      |
| T7_TEMPERATURE                 | T8_TEMPERATURE  |       |         |     |          |         |         |         |        |       |        |                |                |                |                |                |                |                |                |          |      |
| TERMINAL                       | TIME  |       |         |     |          |         |         |         |        |       |        |                |                |                |                |                |                |                |                |          |      |
| <b>START</b>                   | <p>Operates differently depending upon the mode in which the console is running.</p> <p>Console mode:</p> <p><b>START/MEMORY [address]</b> Starts execution of a program on the specified processor at the specified address.</p> <p><b>START/WCS [address]</b> Starts execution of microcode in the WCS at the WCS address specified (between 0 and 3FFF hex).</p> <p>Diagnostic mode:</p> <p><b>START</b> Starts a diagnostic program which is already loaded.</p> <p>[PASSES=passcount] [/SECTION=section_name]</p> <p>[TEST=first_test[:last_test]] [/WCS address]</p>  |       |         |     |          |         |         |         |        |       |        |                |                |                |                |                |                |                |                |          |      |
| <b>VERIFY MODULE_PLACEMENT</b> | <p>Checks that each CPU module is in the correct slot. If all the modules for a CPU are correctly placed, the CPU is marked present. If not, the CPU is marked not present and the missing or misplaced modules are reported.</p>   |       |         |     |          |         |         |         |        |       |        |                |                |                |                |                |                |                |                |          |      |

## 2.4 CONSOLE DISPLAYS AND LOG FILES

The console display for the VAX 8820/8830/8840 system is the console subsystem's VT320 video terminal and/or the remote console terminal. Console sessions at both display terminals are recorded in the console log file. The console log file is maintained on the console storage device.

The console display is composed of console subsystem prompts, operator commands, and console subsystem responses. The text which is echoed back from the system while the user is in program I/O mode is also shown (some entered information, such as passwords, is not echoed by the system and is therefore not displayed). Example 2-8 shows an example of character flow during a local operation.

```
PS-HW-0>VERIFY MODULE_PLACEMENT
PS-HW-0>SHOW CPU
  Current CPU = 0, Current Primary = 0, Next Primary = 0
  Auto — Poweron:disabled, Boot:disabled, Reboot:disabled,
  Restart:disabled
  CPU 0 = Enabled, Present, Available
PS-HW-0>SHOW STATUS
  Power is On, BBU is Disabled
  Clock is Off, Clock period = 70 ns

  CPU   0   1   2   3
Enabled = Y   Y   Y   N
Present = Y   Y   Y   Y
Select  =
Avail   =
Status  =
  Current CPU = 0
  Current Primary = 0
  Next Primary = 0
PS-HW-0>SEL CPU 0
PS-HW-0>@SYSINIT
PS-HW@> SET EL 1
PS-HW@> !+
PS-HW@> ! SYSINIT.COMD — For a VAX xxxx system
PS-HW@> ! REV 1.0
PS-HW@> !
~~~~~
                          (runs the SYSINIT.COMD file)
~~~~~
PS-CIO-0>
```

TTB-0368

### Example 2-8 Console Display Showing a Local Operation

#### 2.4.1 System Log File

The console can maintain a log file of console display activity on the console subsystem storage device (disk). The log file is kept so that activity may be reviewed at a later time. All of the data that appears on the display screen during console-mode operations, as well as the output from the VAX 8820/8830/8840 system, is saved in the log file.

Console entries made during program mode are echoed from the system and are saved in the log file. Entries that are not echoed are not saved.

#### 2.4.1.1 Starting the log file

When starting to log console activity, the operator may specify either system format (compact and comprehensive), or ASCII format (less compact and abbreviated). The default format is system format. The ASCII-format log file is PCON.LOG while the system-format log file is PCONLOG.SYS. The operator may also enable or disable logging. The commands to select the format and to enable/disable logging are:

```
PS-CIO-0> ENABLE LOG/SYSTEM
PS-CIO-0> ENABLE LOG/ASCII
PS-CIO-0> DISABLE LOG/SYSTEM
PS-CIO-0> DISABLE LOG/ASCII
```

#### 2.4.1.2 Size and Number of Log Files

The size and versions of log files which are kept can be specified. The size is specified in blocks with the default size being 1000 blocks. The number of versions to be kept can vary from 1 to 99; the default number of versions is 5. The commands used to specify the size and number of log files are:

```
PS-CIO-0> SET LOG/SIZE=100
PS-CIO-0> SET LOG/KEEP=10
```

The operator may examine the status of logging with the following console command:

```
PS-CIO-0> SHOW LOG
```

#### 2.4.1.3 Examining the Log File

The operator may examine any of the ASCII format log files by entering "TYPE log\_file" or by editing the file with the EDT editor. The system-format log files may not be examined directly, but may be converted to ASCII format files and then examined. The CONVERT command is used to convert a log file to an ASCII-file. The default condition is the current log file. Use:

```
PS-CIO-0> CONVERT log_file
PS-CIO-0> CONVERT/CURRENT
```

## 2.5 THE STAR PROCESS

The STAR process allows a MicroVAX II user terminal to display graphic representations of system status, become the local console, or become a system user terminal.

The STAR process becomes active and handles a user terminal when the person at the user terminal logs into the VAX/VMS Operating System on the MicroVAX II and issues the command "\$STAR". The local console terminal must be logged in and running the POLARIS program.

When the user terminal runs the STAR process it has the ability to cause special graphic system status displays such as module utilization and power subsystem component locations to appear on the terminal. The user terminal must be a VT3xx, a VT2xx, or a VT1xx with the advanced video option (up to 132 characters per line). The following commands can be issued when the user terminal is running the STAR process:

- SET TERMINAL USER
- SET TERMINAL CONSOLE
- SET TERMINAL NOCONSOLE
- EXIT

The user terminal may become a remote console terminal by issuing the command "SET TERMINAL CONSOLE". The prompt for the remote terminal is PS-CC-HW-n> or PS-CC-CIO-n>. PS-CC-HW-n> indicates that the power is on but that the console support microcode (CSM has not yet been loaded into the CPU control store. PS-CC-CIO-n indicates that CSM has been loaded, and the CPU is ready to perform operations such as examining memory locations. All local console terminal commands may be given from the remote terminal except for commands which change power state.

The flowchart shown in Figure 2-4 shows the user terminal states.

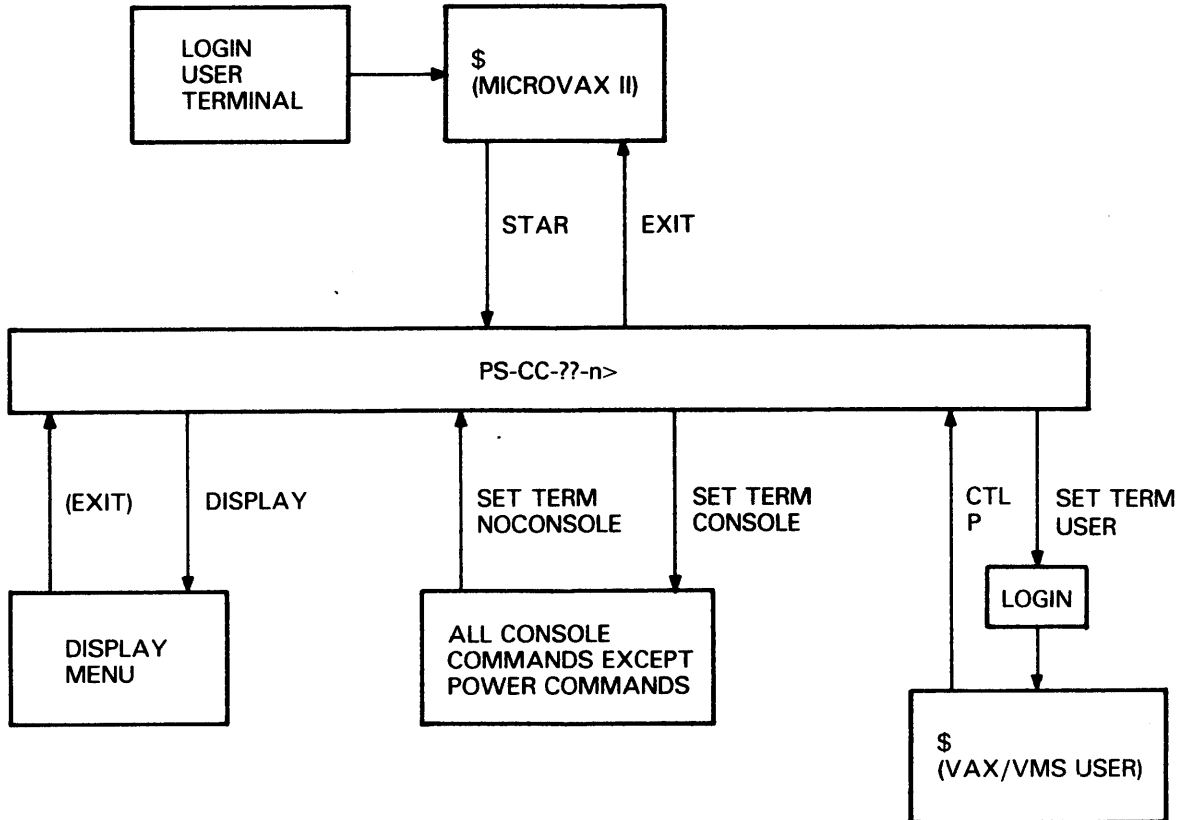

TTB-0315

Figure 2-4 MicroVAX II User Terminal State Flowchart



## CHAPTER 3 FUNCTIONAL DESCRIPTION

### 3.1 OVERVIEW

The VAX 8820/8830/8840 system configuration, shown in Figure 3-1 consists of:

- The console subsystem
- Two CPUs for the VAX 8820 system, three CPUs for the VAX 8830 system, and four CPUs for the VAX 8840 system
- The memory subsystem with one to eight 64-Mbyte arrays
- The power system
- One, two, or three VAXBI interconnect adapters

The VAX 8820/8830/8840 system is interconnected through a synchronous backplane bus called the memory interconnect (NMI). The NMI provides the system with a communications path between the CPU(s), memory, and adapters that connect to the VAXBI interconnects. The NMI is physically separated into two parts: one part in the CPU cabinet connected via a cable and two NMI Bus Window (NBW) modules to the second part in the memory cabinet.

#### NOTE

**The VAX 8820/8830/8840 system must contain at least one VAXBI channel. It can be expanded to contain up to six VAXBI channels (using expansion cabinets).**

**FUNCTIONAL DESCRIPTION**

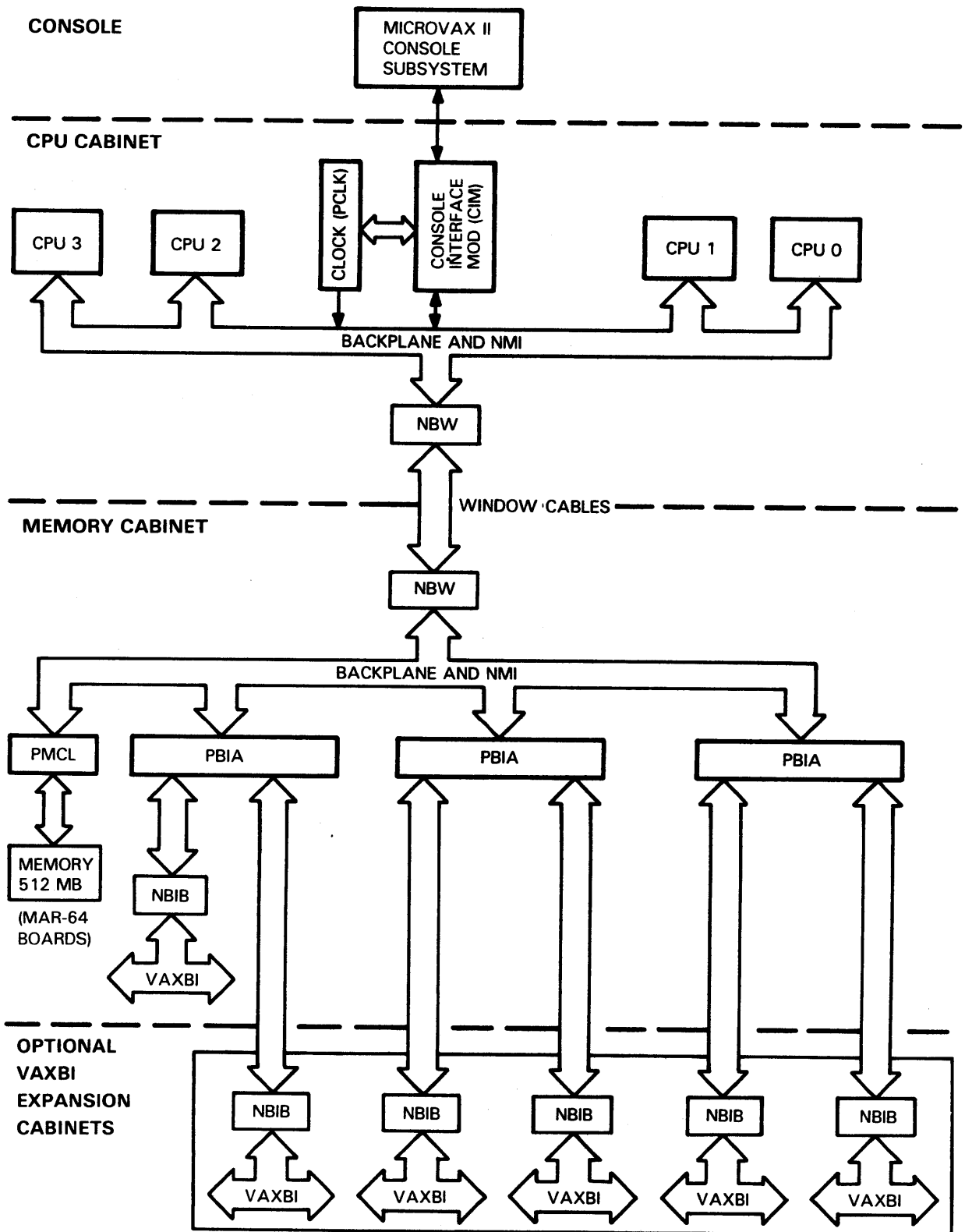

TTB-0274

**Figure 3-1 VAX 8820/8830/8840 System Configuration**

### **3.2 CONSOLE SUBSYSTEM**

The console subsystem, shown in the simplified block diagram in Figure 3-2, controls the power sequencing, loading of control stores, and general operation of the VAX 8820/8830/8840 system. The console subsystem is composed of hardware and software: The hardware part of the subsystem is grouped around the MicroVAX II, which is the "brains" of the subsystem. The software part is made up of the MicroVMS operating system and the console applications procedures which implement the console commands.

**FUNCTIONAL DESCRIPTION**

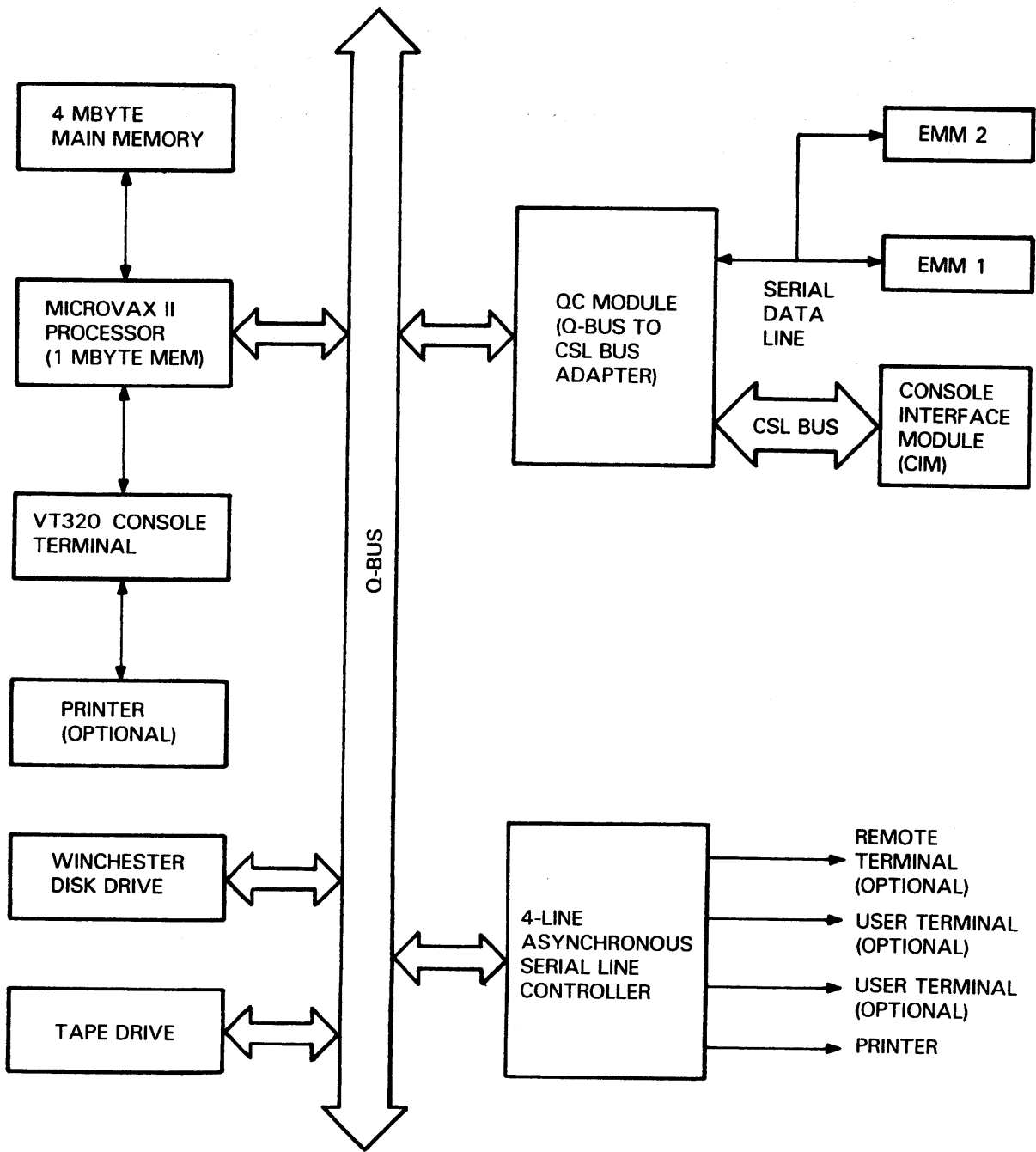

TTB-0275

**Figure 3-2 Console Subsystem Block Diagram**

### 3.2.1 Console Subsystem Hardware

The console subsystem hardware consists of a MicroVAX II system, a QC module, a cable, and a CIM module. The MicroVAX II system communicates with the QC module via the Q-bus. The QC module then communicates with the CM module and the EMM module (one in the CPU cabinet and one in the memory cabinet) over a 4.5-meter (15-foot) cable. The CIM module communicates with the IBox in each of the four CPUs, the VBus, and the PCLK module.

#### 3.2.1.1 The MicroVAX II System

The MicroVAX II system, used in its pedestal configuration, has a 32-bit VAX processor, 5 Mbyte of main memory, a VT320 terminal, a Winchester fixed disk, a removable tape drive, and a communications interface to a printer and optional user terminals (up to three). Refer to the *MicroVAX II Owner's Manual* (AZ-GL1AA-MN) and the *MicroVAX II Technical Manual* (AZ-GL0AA-MN) for further information.

The MicroVAX II processor is contained on a single quad-height board which resides on the MicroVAX Q-bus. It includes the MicroVAX 32-bit central processor, memory management, floating point, one Mbyte of onboard memory, a Q-bus interface, a Q-bus map for DMA transfers, an interval timer, boot and diagnostic facilities, a console serial line, and a time-of-year clock with battery backup.

The console has one Mbyte of memory on the processor module and four Mbytes of memory on a separate memory board.

The VT320 terminal consists of a detachable, low-profile keyboard and a monochromatic video monitor. It includes 15 programmable function keys, multi-national character set support, and plain-language setup menus. The monitor includes a built-in bidirectional printer port. Characters are displayed as a 15-by-12 cell (80-column) matrix or a 9-by-12 (132 column) matrix. The 14-inch non-glare flat screen CRT is available with white, green, or amber phosphor. A terminal/host programmable 25th status line can be optionally used to display system or host status. Advanced video features include double-width and double-height characters, blinking, bold, underline, and normal or reverse video.

The fixed disk drive is an RD53 5-1/4 inch, 71 Mbyte, Winchester drive. It is mounted in the MicroVAX II pedestal cabinet and is controlled by the RQDX3 controller. It holds console subsystem software, system diagnostic test programs, system boot software, and a system message log.

The TK50 removable tape drive, a 95 Mbyte removable-media streaming tape, is suitable for distribution of console software updates and archiving data. A single TK50 tape is capable of holding the contents of an entire RD53 disk. The TK50 is mounted in the MicroVAX II cabinet; its interface requires a half-slot of Q-bus space. Refer to the *TK50 Tape Drive Subsystem User's Guide* (EK-OTK50-UG) for further information.

The optional remote console uses a VT2xx or VT3xx terminal and keyboard, controlled via the DZQ11 asynchronous line controller. This console allows remote diagnosis and control of the VAX 8820/8830/8840 system .

The DZQ11 asynchronous serial line controller is a four-line, asynchronous multiplexer that provides local or remote interconnect to EIA RS-232/423 devices. The DZQ11 operates at program-selectable speeds up to 9600 baud in full-duplex, with limited modem control on each line. The DZQ11 is used in the VAX 8820/8830/8840 system to support an LA75 printer and three user ports (optional). Any one of the three user ports can be used by a terminal (remote or local) which can be logged in as a local or remote (via a modem) operator's console.

An optional printer may be connected to the console subsystem through a serial printer port on the back of the MicroVAX II processor. The printer is not a standard part of the console subsystem.

## **FUNCTIONAL DESCRIPTION**

### **3.2.1.2 The Q-bus Control Module (QC, M7553)**

The Q-bus control module, commonly called the QC module, is a quad-height Q-bus module which interfaces the MicroVAX II Q-bus to the VAX 8820/8830/8840 system EMM and to the CSL bus. The QC module represents a nexus on the Q-bus bus corresponding to 2 kbyte of I/O addresses beginning at 764000 (octal).

The system side of the QC module has two interfaces: an RS-422 serial line and the CSL bus. The RS-422 serial line is used to communicate with the two EMM modules, one in the CPU cabinet and another in the memory cabinet. The CSL bus is used to communicate with the CIM module on the CPU cabinet backplane.

A 4.5-meter (15-foot) cable is used to carry both the CSL bus and the RS-422 serial line from the console to the VAX 8820/8830/8840 system.

### **3.2.1.3 The Console Interface Module (CIM, F1032)**

The console interface module, commonly called the CIM module, is located near the physical center of the CPU logic backplane. Its principal function is to enable the CPUs and the console to communicate via the CSL bus.

There are data paths to the instruction decoder modules of each CPU on the system side of the CIM module. These paths are used by the console to load system microcode, access system registers, and perform file transfers between the system and the console.

The CIM module provides the console access to the clock module (PCLK) so that the console may exercise some control over the system clock. The console may cause the clock to be stopped, started, stepped any number of A-clock cycles, or stopped at preselected program breakpoints.

The CIM module has access to the 32 channels of the system visibility bus (VBus). The VBus is designed to provide the console with access to selected latches within the CPUs for diagnostic purposes. Each channel is a serial path from one of the 32 modules of the four CPUs.

The CIM module can also access backplane revision information and the system serial number.

## **3.2.2 Console Subsystem Software**

The console subsystem software operates in two modes: operator mode, where the console operator may control and monitor the CPU, and program I/O mode, where the console is used like a user terminal. The transient power-up and boot state may be considered to be a third mode of operation.

### **3.2.2.1 Power-up and Boot**

When the machine is first turned on, power is first applied to the system power supply control logic (ILM) and the environmental monitor module (EMM), and then to the console subsystem. The EMM and the console subsystem perform self-test routines to verify their own proper operation.

### **3.2.2.2 Console I/O Mode**

The console operator may use the console in console I/O mode to control and monitor the halted VAX 8820/8830/8840 system. The console I/O mode prompts are listed and described in Table 2-5.

### **3.2.2.3 Program I/O Mode**

Program I/O mode can only be used under the VAX/VMS operating system, ULTRIX operating system, VAX Diagnostic Supervisor (VDS), etc. The console terminal emulates a user terminal while in this mode: The terminal passes all input to the CPU software and displays output from the CPU. The prompt for the program I/O mode is the prompt of the software running at the time, such as the DCL "\$" prompt.

3.3 CENTRAL PROCESSING UNIT

The VAX 8820/8830/8840 system processor, shown in the block diagram in Figure 3-3, consists of three functional units and associated data transfer buses. The functional units and data buses are listed and described in Table 3-1.

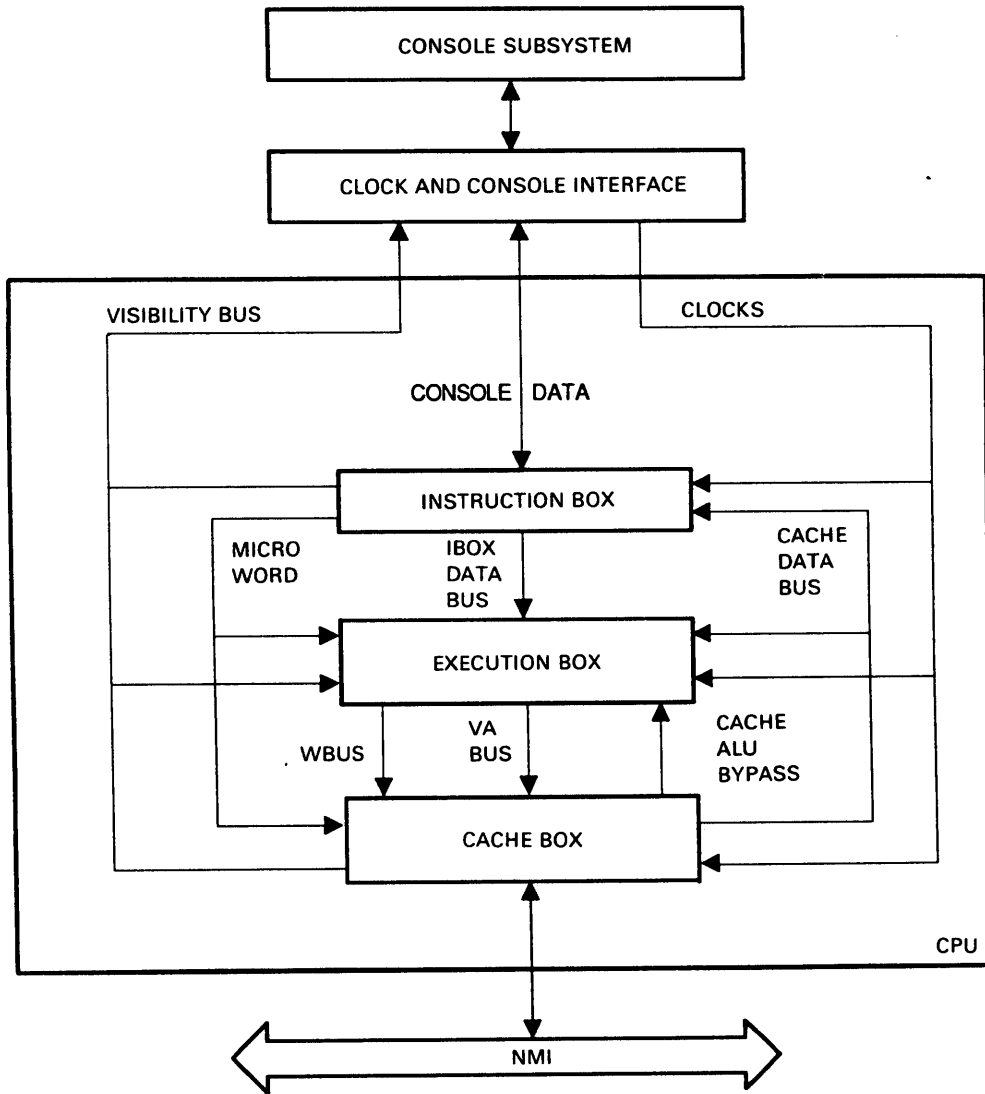

SCLD-78

Figure 3-3 VAX 8820/8830/8840 System Processor Block Diagram

## FUNCTIONAL DESCRIPTION

**Table 3-1 Functional Units and Data Buses**

| <b>Functional Unit/Bus</b>         | <b>Description</b>   |
|------------------------------------|--|
| <b>Instruction Box (IBox)</b>      | CPU microcode store and control. Consists of the writable control store (WCS), the decoder (DEC), and the sequencer (SEQ) modules.   |
| <b>Execution Box (EBox)</b>        | Processes data received from the cache and instruction boxes. Performs arithmetic, logical, and bit-shift operations. The EBox consists of the data slice modules (SLC0 and SLC1) and the shifter (SHR) module.  |
| <b>Cache Box (CBox)</b>            | Contains the cache, translation buffer, and the interface to memory and I/O. The cache is a 64-kbyte physical index, direct mapped and buffered write-through cache. The translation buffer is a 1K direct mapped cache of virtual-to-physical address translations. The CBox consists of the address data path (ADP) and cache control sequencer (CCS) modules. |
| <b>Virtual Address Bus</b>         | Data path for transferring virtual addresses from the execution box to the cache.  |
| <b>Cache Data Bus</b>              | Data path from the cache to the execution box and instruction parser.  |
| <b>Write Data Bus</b>              | Data path for write data from the execution box to the cache.  |
| <b>Cache/ALU Bypass Bus</b>        | Bypass register data that is scheduled to be written into a register. The register does not have valid data yet.   |
| <b>Visibility Bus (VBus)</b>       | Slow-speed data bus that allows the console to access internally-latched data in the CPU modules.  |
| <b>Instruction Buffer Data Bus</b> | Data path for transfer to the execution box. The data consists of byte, word, and longword address displacements, absolute addresses, and immediate data. Branch displacements and literals are also transferred over the instruction buffer data bus.   |

**3.4 CLOCK MODULE (PCLK)**

The clock module contains all of the hardware necessary to generate, control, and distribute the system timing to all system modules. Figure 3-4 shows a simplified block diagram of the clock generation logic on the clock module.

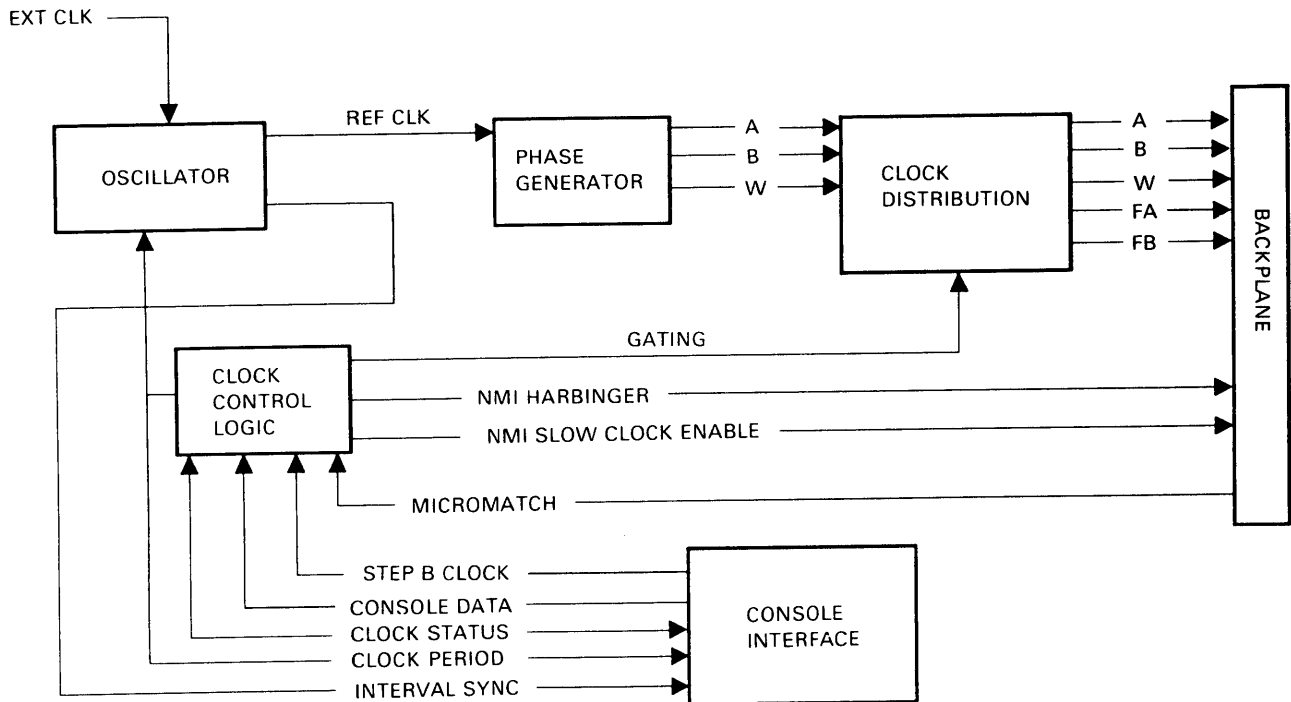

SCLD-83

**Figure 3-4 Clock Generation Block Diagram**

The basic timing source of the clock module is a 250-kHz oscillator and a phase-locked loop used by the phase generator to produce two non-overlapping clock phases.

The phase generator output consists of phases A, B, and W. The W phase signal is similar to the A phase, but longer in duration. The A and B clock phases are gated in the distribution logic by signals from the clock control logic to produce gated system clocks that can be started, stopped, or burst by the clock control logic.

The distribution logic also produces free-running (ungated) clocks. Table 3-2 lists and identifies the clock signals generated and distributed by the clock module.

## FUNCTIONAL DESCRIPTION

Table 3-2 Clock Signals

| Signal Name   | Characteristics   |
|---------------|---|
| A and B CLK   | Main system clocks used by the CPU modules and the I/O adapters to sequence and synchronize operations.   |
| W CLK         | Free-running system clock used in RAM write operations of CPU modules SLC0 and SLC1.  |
| FA and FB CLK | Free-running system clocks used by the memory controller and I/O adapters to sequence and synchronize operations; also used by the console interface to control and monitor the CPUs when clocks are stopped. |

The console subsystem controls the clock generation logic with operator-initiated commands by means of the console interface. Three registers within the clock logic are used for control of the system clocks by the console; a fourth register provides status information for the console operator. The following registers are used:

- Clock control
- Clock period
- Burst count
- Timeout and status

Console control of the clocks allows the system operator to:

- Start and stop the clocks
- Burst the clocks
- Single-step the clocks
- Enable a clock stop on a micromatch
- Change the clock period
- Disable clock stalls
- Control the NMI timeout clock (NMI Slow Clock Enable)

### 3.5 MEMORY (MBOX)

System memory system (MBox) consists of a memory control logic (PMCL) module and one to eight MAR64 64-Mbyte memory array boards. Figure 3-5 shows a simplified block diagram of the MBox with one MAR64 array board.

#### NOTE

The standard VAX 8820/8830/8840 system main memory can be expanded to 512 Mbytes by installing MAR64 64-Mbyte memory array boards. This memory expansion upgrade can be effected by adding up to eight (total) MAR64 memory arrays.

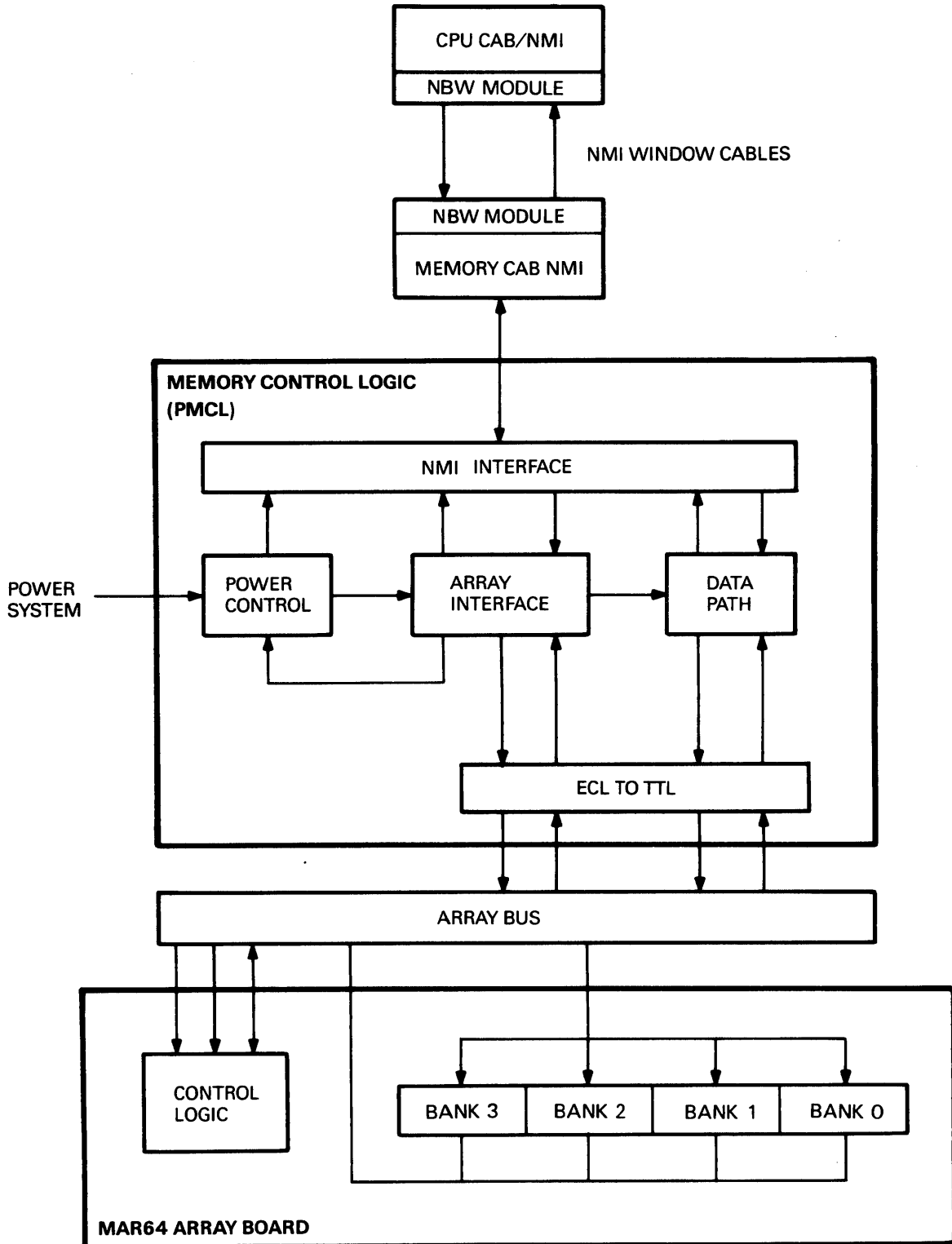

TTB-0276

Figure 3-5 Memory Subsystem Block Diagram

## FUNCTIONAL DESCRIPTION

### 3.5.1 Memory Control Logic

The PMCL provides control and a communications interface between the NMI and the memory array boards. The single PMCL has the capability of controlling a maximum of eight array boards, and can monitor operations on three arrays simultaneously. Table 3-3 describes the operations that the PMCL performs on the MAR64 array.

**Table 3-3 PMCL Command Operations**

| <b>Operation</b> | <b>Description</b>   |
|------------------|--|
| Longword Write   | Writes a data longword and seven ECC check bits into one of the MAR64 array banks. |
| Longword Read    | Reads a data longword and seven ECC check bits from one of the MAR64 array banks.  |
| Octaword Read    | Reads four data longwords and associated check bits from a MAR64 array.            |

### 3.6 SYSTEM BUSES

The VAX 8820/8830/8840 system has three system-level buses that provide a path for data transfers and status information.

- VAX 8820/8830/8840 system memory interconnect (NMI)
- VAX backplane interconnect (VAXBI)
- Visibility bus (VBus)

The system memory interconnect (NMI) is a backplane bus that interconnects the major system components and allows transfer of data between the connected units. The NMI is separated into two physical parts: the CPU NMI and the memory NMI. The two NMIs are connected by two NBW modules and a cable. During normal operation it is not obvious to the CPUs that the NMI is in two parts.

The VAXBI interconnect is the I/O bus that provides a connection point between the system and external device adapters.

The visibility bus provides the console operator with diagnostic access to internal latch contents. The VBus is also used to perform error checks during initialization.

Figure 3-6 shows the major system buses.

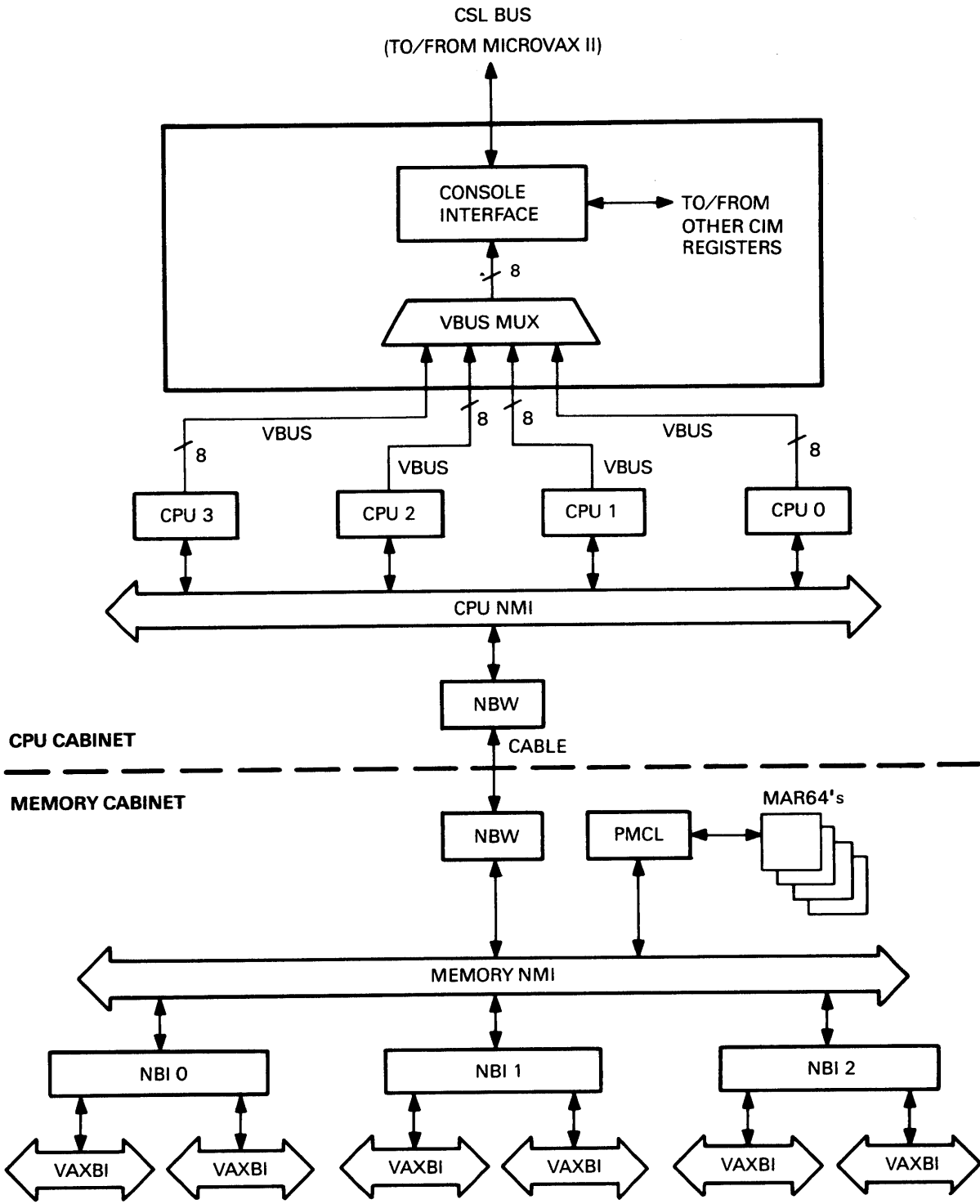

TTB-0277

Figure 3-6 System Buses

## **FUNCTIONAL DESCRIPTION**

### **3.6.1 Memory Interconnect (NMI)**

The NMI, shown in Figure 3-7, is a synchronous backplane bus that interconnects the following major components of the VAX 8840/8830/8820 systems:

- 2, 3, or 4 CPUs (VAX 8820, 8830, or 8840 system)
- 2 NMI bus window modules (NBWs)
- Memory system controller (PMCL)
- NMI-to-VAXBI adapters (PBIA, up to 3)

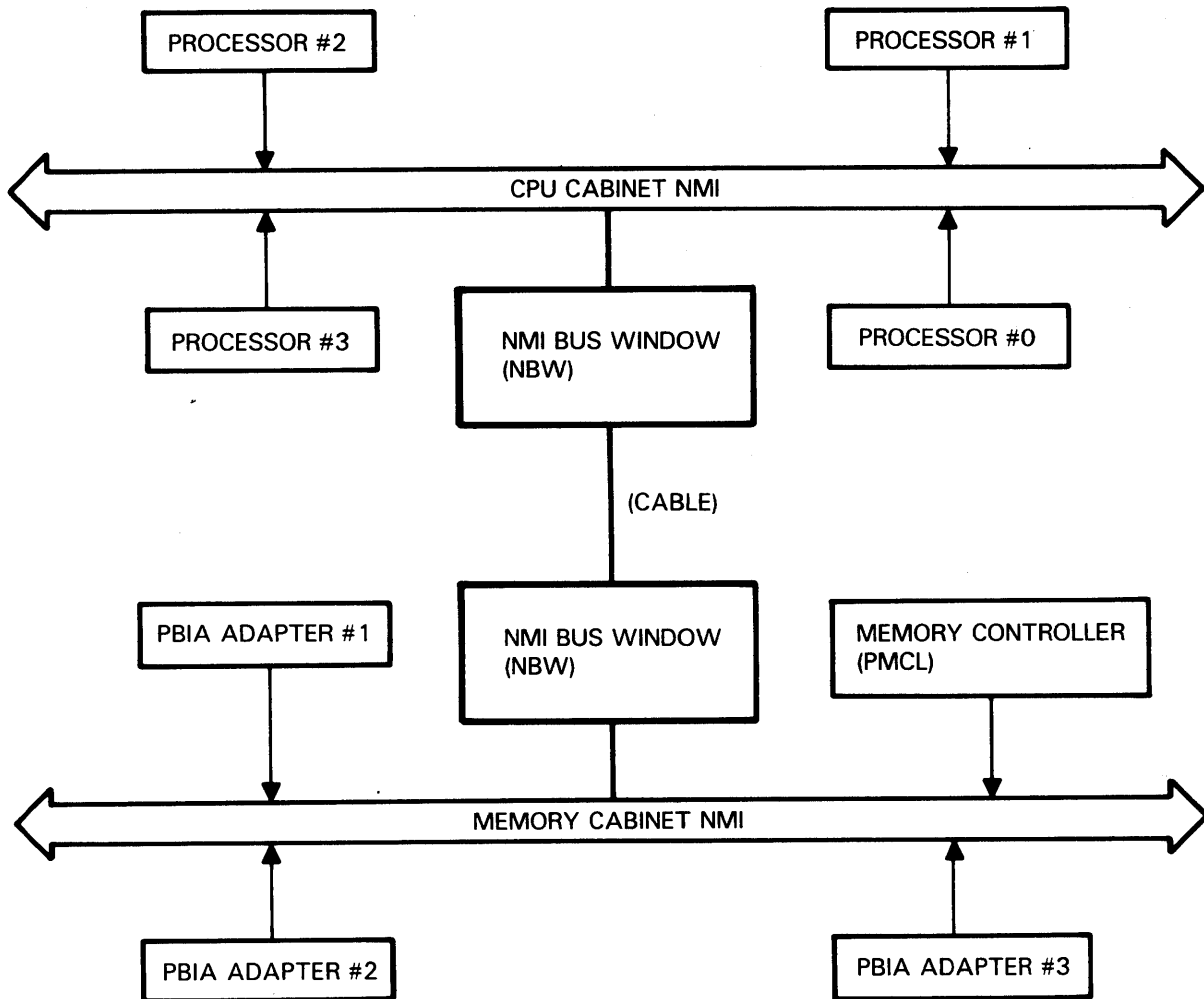

TTB-0278

Figure 3-7 NMI Block Diagram

Table 3-4 lists the primary functions performed by the NMI, and provides a brief description of each of the functions.

## FUNCTIONAL DESCRIPTION

**Table 3-4 NMI Primary Functions**

| <b>Function</b>                    | <b>Description</b>  |
|------------------------------------|---|
| Write Transaction                  | Supports longword, quadword, and octaword write.  |
| Read Transactions                  | Supports longword, octaword, and hexword read.  |
| Memory Read/Write Operations       | Allows the CPUs and I/O adapters to access memory through bus read/write transactions.                                    |
| I/O Register Read/Write Operations | Allows the CPUs to access I/O registers in the memory, I/O adapters, and I/O devices through bus read/write transactions. |
| Interrupt Handling                 | Transmits interrupt requests generated by the memory and I/O adapters to the CPUs.  |
| System Synchronization             | Provides system clocks to all nexus (hardware blocks physically connected to the NMI).                                    |
| System Initialization              | Allows the console to initialize all nexus.   |
| Power-Fail Warning                 | Provides ACLO and DCLO signals to all nexus.  |

### **3.6.2 VAXBI Interconnect**

The VAXBI interconnect is the I/O bus for the system and is connected to the system through the NMI-to-VAXBI (NBI) adapter, as shown in Figure 3-8. Each NBI adapter can interface a maximum of two VAXBI interconnects and provides for a maximum of six VAXBI interconnects to the system when three NBI adapters are installed.

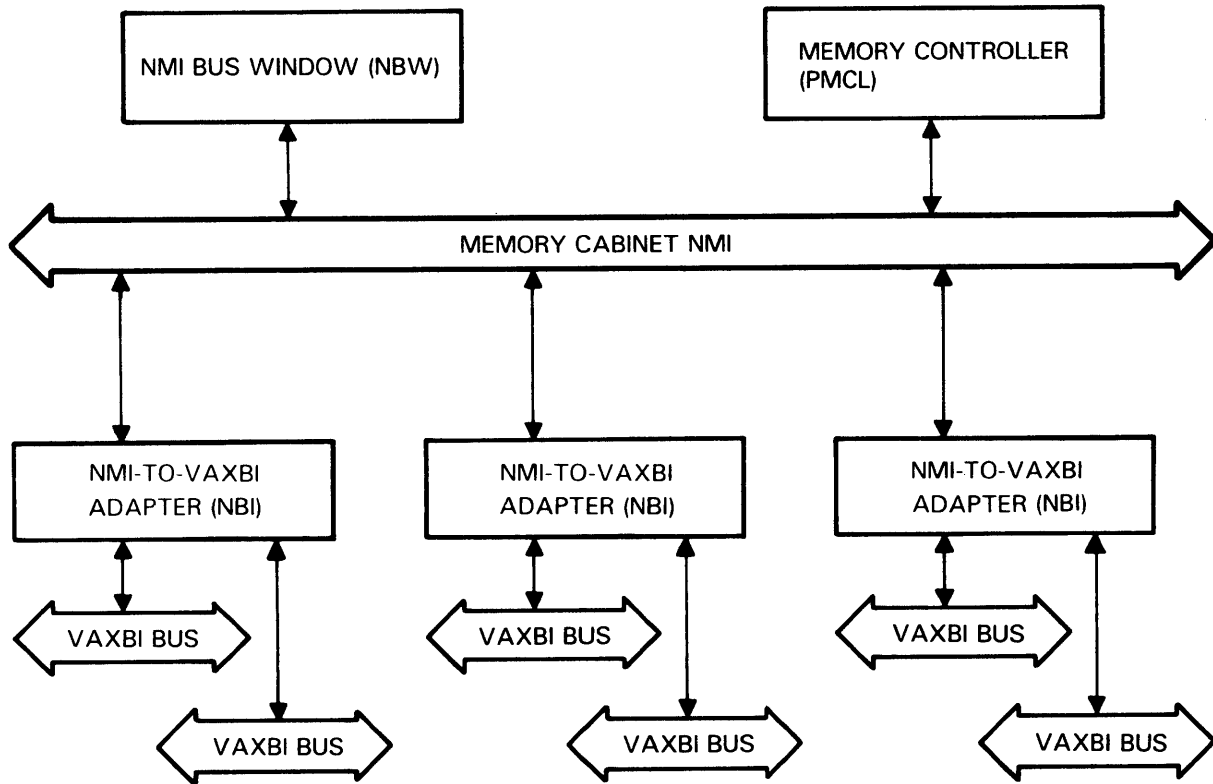

TTB-0279

Figure 3-8 VAXBI Block Diagram

The VAXBI is a 32-bit wide synchronous bus that interconnects a maximum of 16 VAXBI interfaces (VAXBI nodes) with logical addresses of 0 through F (hex). The address of a node is determined by an ID plug inserted on the backplane.

**NOTE**

**Address 0 usually is reserved for the NBI node.**

The remaining nodes consist of I/O device controllers and bus adapters interfacing the system's I/O devices to the VAXBI interconnect.

Table 3-5 identifies and describes the basic functions performed by the VAXBI interconnect.

## FUNCTIONAL DESCRIPTION

**Table 3-5 VAXBI Functions**

| <b>Function</b>                    | <b>Description</b>  |
|------------------------------------|---|
| Memory Read/Write Operations       | Allow DMA transfers between an I/O device on the VAXBI and main memory through bus read/write transactions.                         |
| I/O Register Read/Write Operations | Allows the CPUs to access I/O registers in the I/O devices on the VAXBI through bus read/write transactions originating on the NBI. |
| Interrupt Handling                 | Enables I/O devices on the VAXBI to interrupt a CPU through bus INTR transactions directed to the NBI node.                         |
| System                             | Allows nodes to assert a reset line and initialize a simulated VAXBI powerfail sequence generated by the NBI.                       |
| Powerfail Warning                  | Provides ACLO and DCLO signals to all nodes.  |

### 3.6.3 Visibility Bus (VBus)

The visibility bus, shown in Figure 3-9, is a slow-speed bus consisting of sixteen data lines and two control lines. The VBus allows the console operator to read internally latched data in the CPU modules during the execution of microdiagnostics and system initialization. The VBus is used when the system clocks are stopped. Major functions performed by the VBus include:

- Monitoring the state of the CPUs during the execution of microdiagnostics or in response to commands entered at the console during system debugging
- Verifying CPU module installation and revision during system initialization
- Ensuring that control store parity errors do not occur when loading microcode during system initialization

The console controls and reads the VBus by means of two registers located on the clock module's console interface. The VBus control and access registers perform the following functions:

- Select the VBus input channel
- Step the clocks that operate the VBus
- Send serial VBus addresses to the CPU modules
- Halt the operation of the VBus address shift register

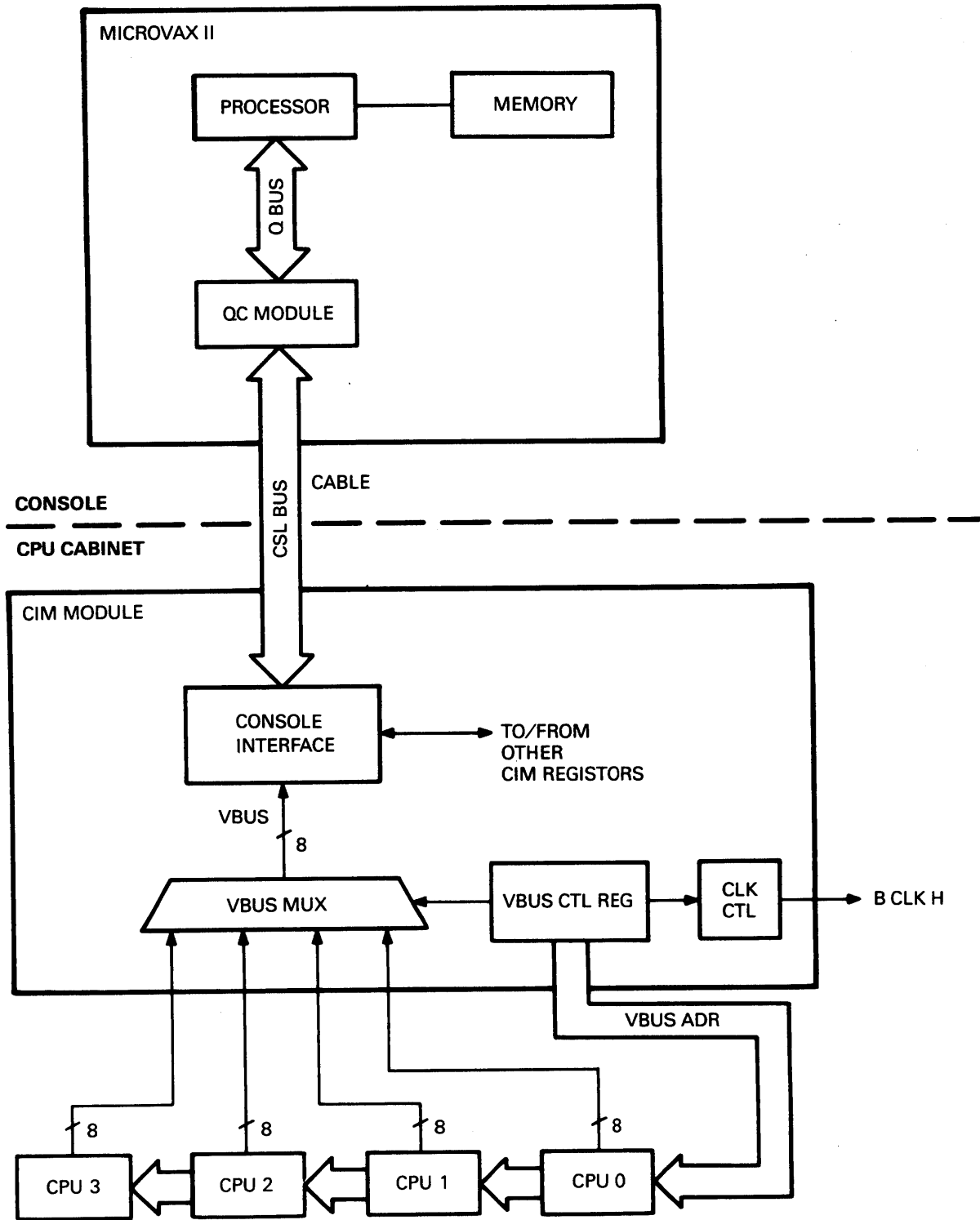

TTB-0280

Figure 3-9 VAX 8820/8830/8840 System Visibility Bus (VBus)

**3.6.4 VAXBI Interconnect and I/O Adapters**

The system memory interconnect-to-VAXBI interconnect (NBI) adapters provide a connection point for the VAX 8820/8830/8840 system to the VAXBI interconnect. Additional optional adapters can be connected to the VAXBI interconnect (see Figure 3-10) to allow connection of the CPUs to other I/O devices. Table 3-6 lists and identifies some of the optional adapters that can be connected to the VAXBI interconnect.

The NMI-to-VAXBI (NBI) adapter, shown in Figure 3-11, consists of a PBIA module that interfaces to the NMI, and one or two NBIB modules. The NBIB modules interface to the VAXBI interconnect through the use of a VAXBI interface chip (BIIC).

The PBIA module contains the NMI nexus registers, and the NBIB module contains the VAXBI connecting registers. Table 3-7 and Table 3-8 list and identify the registers on each module.

**Table 3-6 Optional VAX Bus Interconnect Adapters**

| <b>Adapter</b> | <b>Function</b>   |
|----------------|---|
| KDB50-BA       | VAXBI Bus-to-Storage Interconnect disk controller.                                  |
| DEBNA          | VAXBI Bus-to-Network Interconnect controller. Uses Ethernet.                        |
| CIBCA-A        | VAXBI Bus-to-Computer Interconnect controller.                                      |
| CIBCA-B        | VAXBI Bus-to-Computer Interconnect controller.                                      |
| KLESI          | VAXBI Bus-to-Native tape controller.  |
| DMB32          | VAXBI Bus-to-Native asynchronous communications controller.                         |
| DRB32-M        | VAXBI parallel interface.   |
| DRB32-W        | VAXBI DR11-W Emulator module plus DRB32-M.  |
| DRB32-E        | "Long-line" module plus DRB32-M.  |
| DWBUA          | VAXBI Bus-to-UNIBUS Controller. UNIBUS support limited to: LP11, DR11-W, and DUP11. |

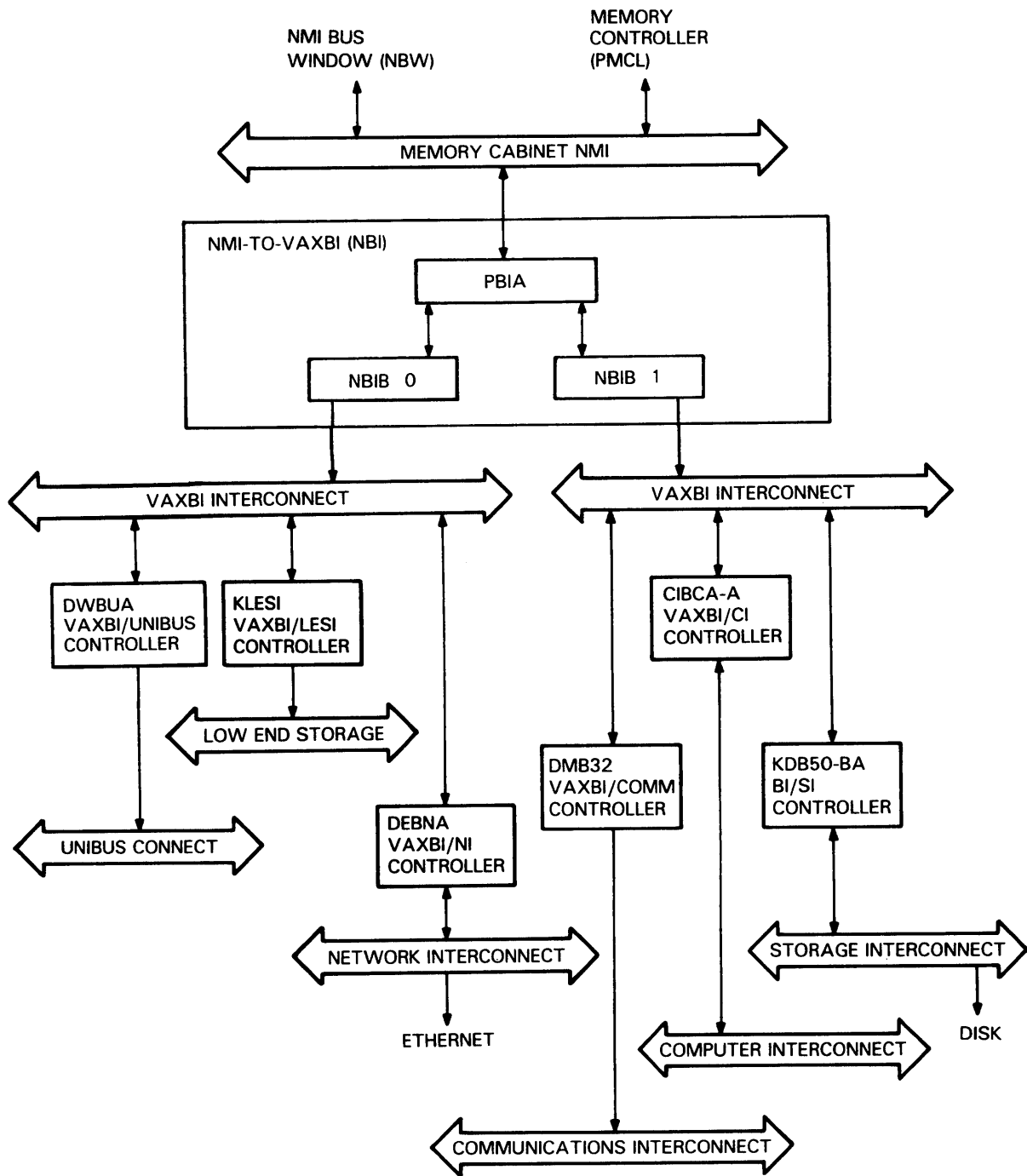

TTB-0281

Figure 3-10 VAXBI Optional Adapters

**FUNCTIONAL DESCRIPTION**

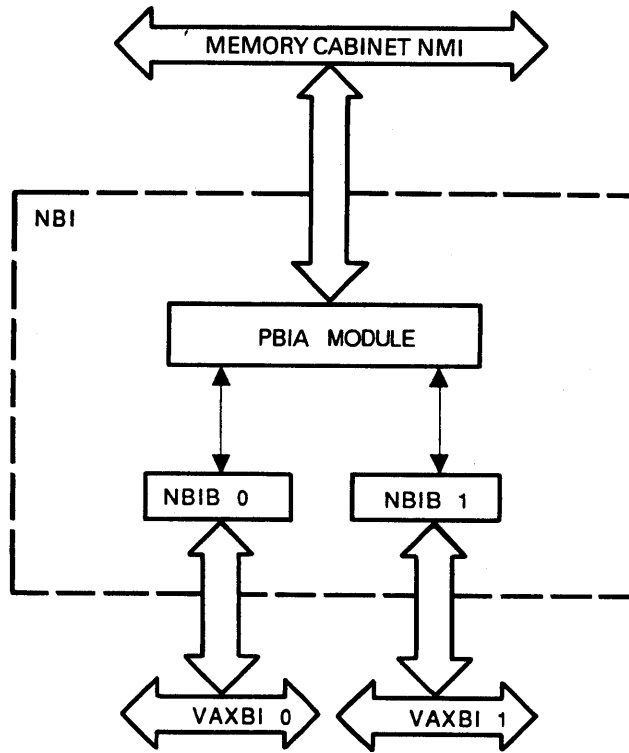

TTB-0282

**Figure 3-11 NMI to VAXBI Interconnect Adapter (NBI)**

**Table 3-7 PBI A Registers**

| Address  | Register                     |
|----------|------------------------------|
| 2X080000 | Control/Status 0 (CSR0)      |
| 2X080004 | Control/Status 1 (CSR1)      |
| 2X080008 | VAXBI 0 Stop Register (BIOI) |

X = 0 = PBI A 0  
 = 4 = PBI A 1  
 = 8 = PBI A 2

**Table 3-8 NBIB Registers**

| Address  | Register                 |
|----------|--------------------------|
| 2X080000 | Device Type              |
| 2X080004 | VAXBI Control/Status     |
| 2X080008 | Bus Error                |
| 2X08000C | Error Interrupt Control  |
| 2X080010 | Interrupt Destination    |
| 2X080014 | IP Interrupt Mask        |
| 2X080018 | IP Interrupt Destination |
| 2X08001C | IP Interrupt Source      |
| 2X080020 | Starting Address         |
| 2X080024 | Ending Address           |
| 2X080028 | BCI Control              |
| 2X08002C | Write Status             |
| 2X080040 | User Interrupt Control   |

X = 0 = PBIA 0/BI 0  
 = 2 = PBIA 0/BI 1  
 = 4 = PBIA 1/BI 0  
 = 6 = PBIA 1/BI 1  
 = 8 = PBIA 2/BI 0  
 = A = PBIA 2/BI 1

### 3.7 POWER SYSTEM

The power system provides the voltages necessary to operate the CPUs, memory, and the VAXBI interconnect. Three-phase ac utility power is used as the primary source for the system. The required ac and dc voltages are developed using the power modules and voltage regulators located within the VAX 8820/8830/8840 system cabinet. Figure 3-12 shows a simplified block diagram of the power system, and Figure 3-13 indicates the physical location of the power system components.

## FUNCTIONAL DESCRIPTION

### 3.7.1 880A/B Power Controller

The 880A/B controller is the main ac input module for the power system. Power is received from the main circuit breaker and is distributed to the other system components by the 880A/B controller. The power controller distributes the power as shown in Table 3-9.

**Table 3-9 Power Distribution by the 880/B Power Controller**

| <b>Unit</b>           | <b>Power</b>            |
|-----------------------|-------------------------|
| <b>CPU cabinet</b>    |                         |
| SST Box               | Switched three-phase    |
| Console               | Unswitched single-phase |
| Air mover             | Switched three-phase    |
| <b>Memory cabinet</b> |                         |
| PBox                  | Unswitched single phase |
| BBU                   | Unswitched single-phase |
| Air Mover             | Switched three-phase    |

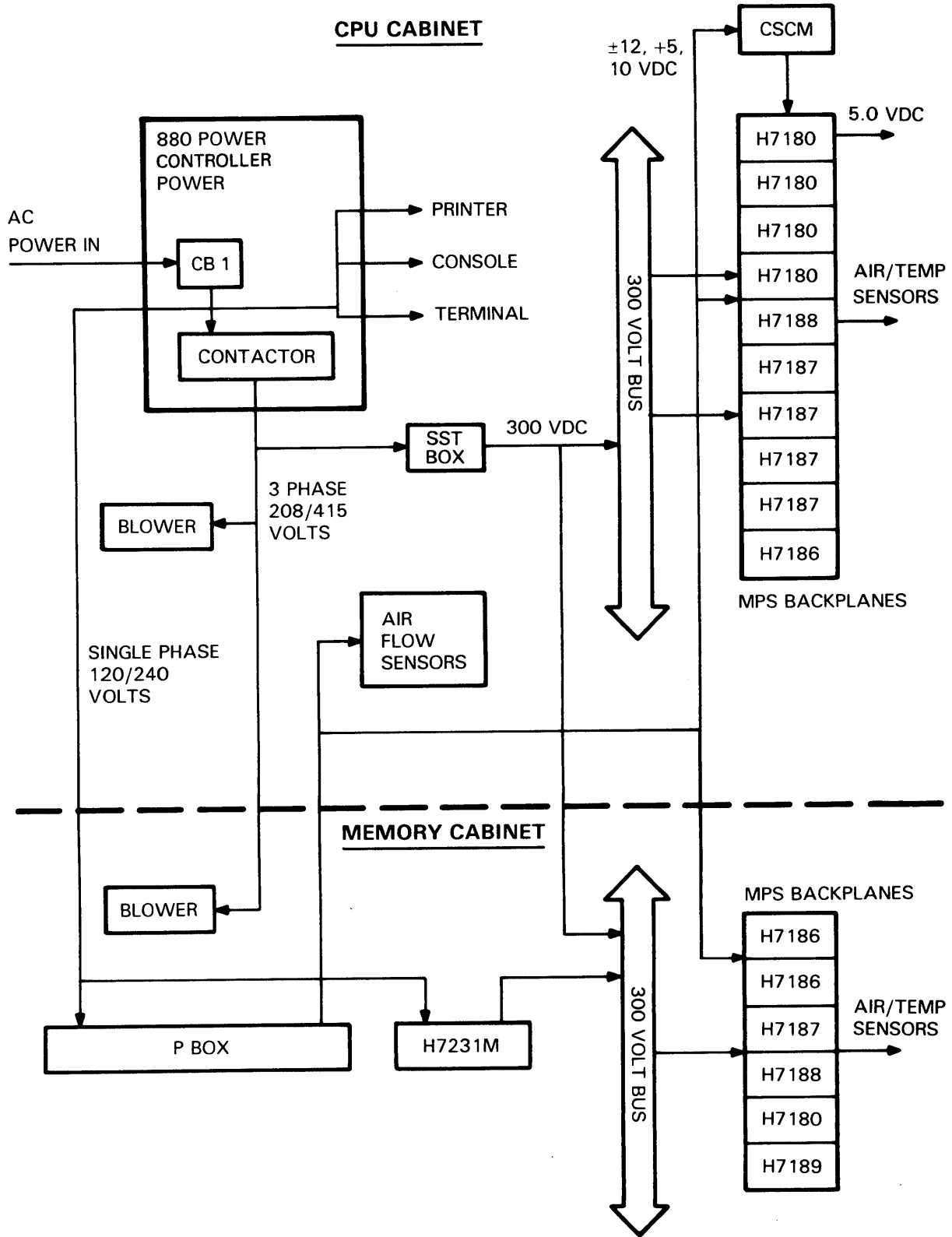

TTB-0283

Figure 3-12 Power System Block Diagram

**FUNCTIONAL DESCRIPTION**

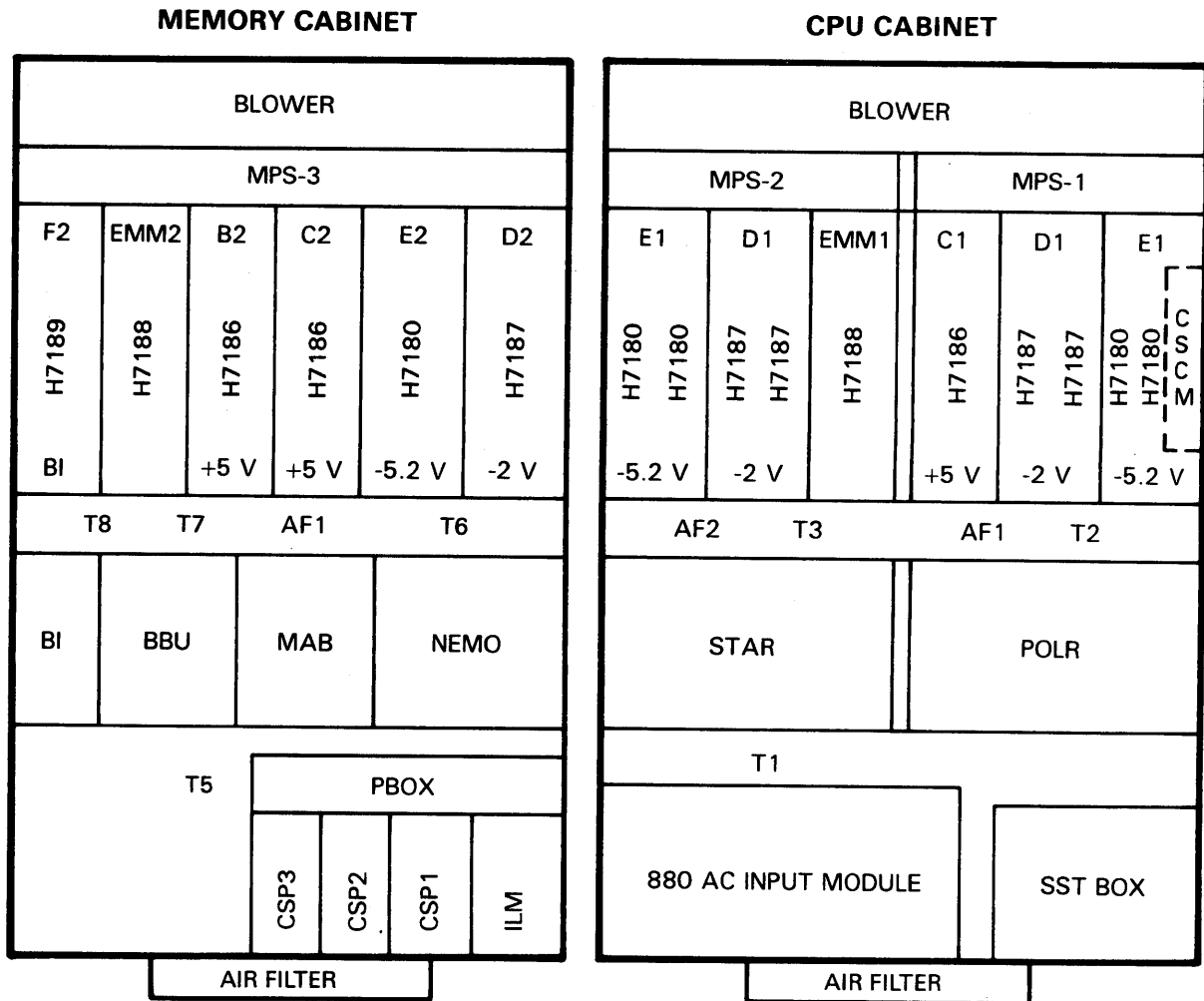

TTB-0284

**Figure 3-13 Physical Location of the Power System Components**

- T1, T5 = Ambient Air Temperature Sensors
- T2, T3, T6, T7, T8 = Exhaust Air Temperature Sensors
- T4 not connected
- AFn = Air Flow Sensors

**3.7.2 Solid-State Transformer Box (SST)**

The solid-state transformer box converts three-phase ac power to 300-V dc power and sends the 300 V dc power to the four 300 V dc MPS buses. Systems designed for 50-Hz operation require a buck converter, which takes the output of the SST (600 V dc for the 50-Hz, 416/380-V ac configuration) and changes it to 300 V dc.

**3.7.3 PBox Port Conditioner**

The PBox is a multifunction power assembly containing four modules: three CSP modules and one ILM module.

The primary purpose of the CSP modules (Control and Startup Power, H7060A) is to provide basic power to the control modules of the power subsystem. Upon receiving startup power, these modules begin controlling operation of the power subsystem.

The primary purpose of the ILM module (H7061A) is to provide an interface and to condition signals passing between the various modules of the power subsystem.

**3.7.4 Module Power Supplies**

The module power supplies (MPS) are a group of dc power modules and three backplanes. Two MPS backplanes are located above the CPU card cage in the CPU cabinet; the third is located above the logic card cages in the memory cabinet. The MPS backplanes contain the regulated dc power supplies that provide the operating power for the CPUs, NBWs, memory, and VAXBI(s).

**3.7.5 Environmental Monitoring Module**

The environmental monitoring module (EMM) is a microprocessor-based unit that monitors the power and environmental conditions within the system. The EMM responds to console control commands during power-up and power-down sequencing, initialization, and battery backup operations. The console controls the power system through the EMM.

**3.7.6 Battery Backup Unit**

The battery backup unit (BBU) gives the power system a method of providing backup power to the CPU memory during an ac power failure. The BBU contains a 48-V dc rechargeable battery pack, charging circuit, and a dc-to-dc converter. The converter provides 300 V dc for up to ten minutes during the backup mode.



## CHAPTER 4

# VAX 8820/8830/8840 SYSTEM MAINTENANCE

### 4.1 INTRODUCTION

This chapter contains console troubleshooting procedures that will provide you with assistance before calling Field Service. A procedure for setting up a remote diagnostic session also is included.

### 4.2 PREVENTATIVE MAINTENANCE

The only preventative maintenance required on the VAX 8820/8830/8840 System is to clean the filters. The system has two metallic filters located in the bottom of the system cabinet. Both filters should be removed and cleaned at 60-day intervals. Filter service should only be performed by trained and qualified personnel. If the system is under warranty, or is covered by a standard Digital service contract, preventative and corrective maintenance can be performed only by authorized DIGITAL service personnel.

#### WARNING

**The system cabinets contain potentially dangerous voltages as well as static-sensitive components. Access to the interior of the cabinets using the cabinet opening tool (DEC PN 12-26339) for any type of maintenance should be restricted to trained and qualified service personnel.**

### 4.3 CONSOLE SUBSYSTEM HARDWARE SELF-TESTS

The console subsystem contains a complete set of hardware self-test programs that check all of the major console system functions. If a problem is found, the self-test program identifies the nature of the problem. The self-test is completely automatic and runs each time the console is powered up. The console terminal will appear as shown in Example 2-1 when the tests complete without failure.

The MicroVAX II powerup self-test sequence consists of 16 ROM based tests, which are run when MicroVAX II power is turned on. They are numbered from 0 to F (hex). The tests are run starting at test F and ending with test 0. Tests F through A cause no display at the console terminal. When test 9 (Identifying Console Terminal) runs successfully, a heading which reports the version of the CPU in the MicroVAX II (KA630) is displayed on the terminal. Test number 8 does not cause a display but successful completion of each test from 7 down to 0 causes the number of the successful test to be displayed on the console terminal. The self-tests, in order of their execution, are:

- F. Waiting for DC OK
- E. Waiting for P OK
- D. Running CHECKSUM Test on CPU ROM
- C. Searching for RAM Memory Required for CPU ROM Programs
- B. Reading KA630-A IPCR Register (accesses Q22-Bus)
- A. Testing VCB01 Video Console Display (if present)
9. Identifying Console Terminal
8. Language Inquiry or CPU Halted
7. Running Data Tests on RAM Memory
6. Running Address Tests on RAM Memory
5. Running Tests That Use Q22-Bus Map to Access Local Memory

4. CPU Instruction and Register Tests
3. Running Interrupt Tests
2. Searching for Bootstrap Device
1. Bootstrap Device Found
0. Testing Completed

#### 4.4 CORRECTING SIMPLE PROBLEMS

Table 4-1 is a quick reference source for correcting simple problems.

**Table 4-1 Correcting Simple Problems**

| Symptom  | Possible Condition  | Corrective Action  |
|--|---|--|
| Nothing happens when the console power switch is turned on.                    | The power cord is not connected.  | Reconnect the power cord to the VAX 8820/8830/8840 system cabinet.   |
|  | The MicroVAX II circuit breaker has tripped.                            | Turn MicroVAX II power off and reset the circuit breaker.  |
|  | Power is not received from the system CPU cabinet.                      | Verify that circuit breaker 5 is in the ON position.   |
|  | The VAX 8820/8830/8840 system has entered the automatic shutdown phase. | Attempt a power up of the VAX 8820/8830/8840 system.<br><br>If the power up attempt is unsuccessful, contact a Digital Field Service technician. |
| Nothing appears to happen when the power switch is ON, but the fan is running. |   | Refer to the <i>Console User's Guide</i> for power-up procedures.  |
|  |   | Call Field Service.  |

**4.5 WHAT TO DO IF YOU HAVE TO CALL FOR SERVICE**

Digital Equipment Corporation has a central service point in your area to help you get your system running with a minimum of trouble. Before calling for service, please do the following:

1. Write down the serial number of your system.
2. Summarize the problem and make a note of what you were doing when the system failed.
3. If at all possible, place the service call in close proximity to the system. The service person may ask you to reproduce some of the failing procedures in order to obtain additional information.
4. Be prepared to set up a remote diagnostic session if necessary. See section 4.6 for remote diagnosis procedures.

Call Digital Equipment Corporation at one of the following telephone numbers:

| Location                   | Telephone Number                   |
|----------------------------|------------------------------------|
| Belgie/Belgique            | 02-24 26 790                       |
| Bundesrepublik Deutschland | 089-95 91 66 44                    |
| Canada                     | (800)-267-5251                     |
| Danmark                    | 04-30 10 05                        |
| Espana                     | 1-73 34 307                        |
| France                     | 1-687 31 52                        |
| Italia                     | 02-61 75 381<br>or<br>02-61 75 382 |
| Japan                      | (03)-989-7161                      |
| Nederland                  | 1820-31 100                        |
| Osterreich                 | 222-67 76 41 App. 444              |
| Suisse/Schweiz             | 01-81 69 270                       |
| Suomi                      | 90-42 33 32                        |
| Sverige                    | 08-98 88 35                        |
| United Kingdom             | 0256-59 200                        |
| United States              | 1-(800)-DEC-8000                   |

## 4.6 REMOTE DIAGNOSIS

Remote diagnosis provides a method for troubleshooting the VAX 8820/8830/8840 system from the Digital Service Center. Remote troubleshooting requires connecting the system to the Remote Services Console (RSC) and connecting the RSC to a telephone line by means of a DF112 modem (or equivalent). Further information on the RSC is available in the *RSC Field Service Manual* (EK-KCRSC-FS). Additional information on the DF112 modem is available in Appendix A of this manual and in the *DF112 Modem User's Guide* (EK-DF112-UG).

### 4.6.1 Remote Diagnosis Configurations

The RSC may be connected in one of two configurations. The first configuration allows the DIGITAL Service Center to have full local console control, while the second configuration allows the Service Center to have limited local console control. The first configuration is recommended as it allows the Service Center to exercise the system more fully and gain more diagnostic information.

For full console control, the RSC connects the local console terminal to OPA0, and the remote console terminal to OPA0 or TTA0. When the RSC keyswitch is at REMOTE, the Service Center (via modem) has control of OPA0. When the RSC keyswitch is at REMOTE USER, the DIGITAL Service Center (via modem) is connected to TTA0. With the RSC keyswitch in LOCKOUT, all remote activity is terminated and the local console terminal has a direct connection to the MicroVAX II.

For limited console control, the RSC connects the remote console terminal to TTA0. When the RSC keyswitch is at REMOTE USER, the Service Center (via modem) is connected to TTA0. When the RSC keyswitch is at LOCKOUT, all remote activity is terminated and the local console has a direct connection to the MicroVAX II. There is always a direct connection from the local console terminal to OPA0. In this mode, commands specific to OPA0 will not be allowed through the remote console. Commands not allowed are:

- QUIT
- ENABLE/DISABLE PRINTER
- ENABLE/DISABLE REMOTE\_USER
- ENABLE/DISABLE HARDWARE
- ENABLE/DISABLE FUNCTIONAL\_SIMULATION
- ENABLE/DISABLE DECSIM
- ENABLE/DISABLE DUAL
- ENABLE/DISABLE REMOTE\_CONSOLE
- POWER ON/OFF/STANDBY
- EMM

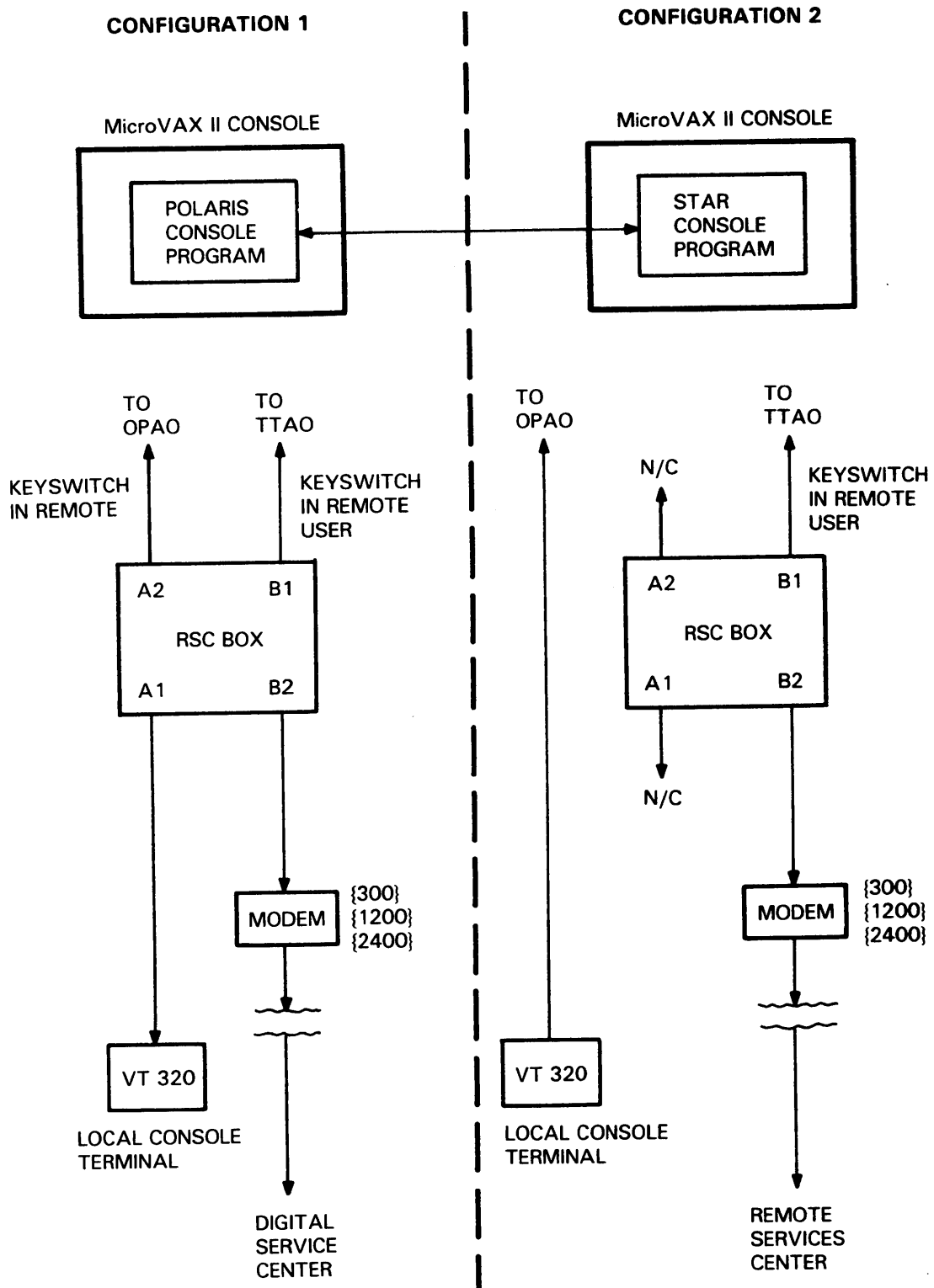

TTB-0369

Figure 4-1 Remote Console Configurations

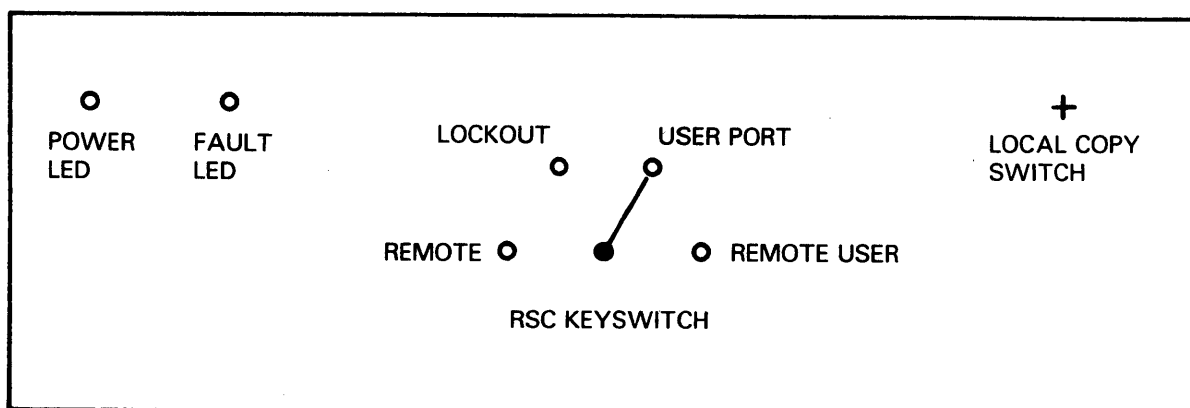

TTB-0370

**Figure 4-2 Remote Services Console Front Panel Switch Locations**

#### 4.6.2 Setting Up for a Remote Diagnosis Session

VAX 8820/8830/8840 systems with a DIGITAL maintenance contract will have a remote diagnosis configuration installed. This section explains how to initiate a diagnosis session through the DIGITAL Remote Diagnosis Center (RDC) when a system performance problem is suspected.

The system manager (or her/his agent) should use the following steps to initiate a remote diagnosis session when the system does not appear to be performing properly:

1. Prepare for the call by gathering information as suggested in section 4.5.
2. If the system is set for limited remote console control, enter these two commands on the local console:
  - ENABLE REMOTE USER
  - ENABLE REMOTE CONSOLE
3. Make sure that the console is in local console mode.
4. Place the Remote Services Console front panel switch in the REMOTE position.
5. Call the Remote Diagnosis Center (RDC) and tell them that you want them to perform a remote diagnosis session on your system.

## **APPENDIX A**

### **DF112 MODEM INFORMATION**

#### **A.1 INSTALLING THE DF112 MODEM.**

The following procedures are used to unpack and install the DF112 Modem. Refer to the *DF112 Modem User's Guide*, (EK-DF112-UG) for additional information.

1. Unpack, inspect, and set up the DF112 modem. (Install the stand-alone modules if required.)
2. Connect the modem to the public telephone network using either the handset connection or the direct telephone line connection on the rear of the DF112 modem (see Figure A-1).
3. Connect one end of a null-modem cable to the Data Terminal Equipment (DTE) connector on the rear of the DF112 modem (refer to Figure A-1); connect the other end of the cable to the chosen user port on the MicroVAX II console.
4. Set the DF112 front panel controls to the desired operating positions (refer to the *DF112 Modem User's Guide*).

**DF112 MODEM INFORMATION**

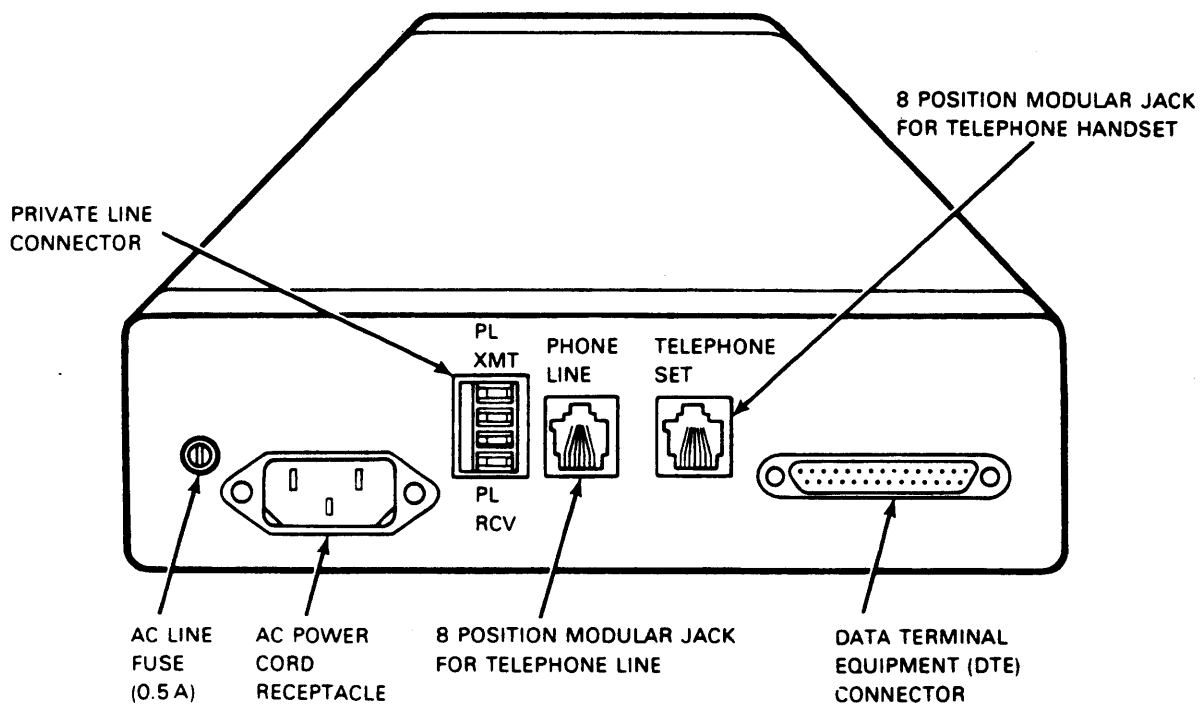
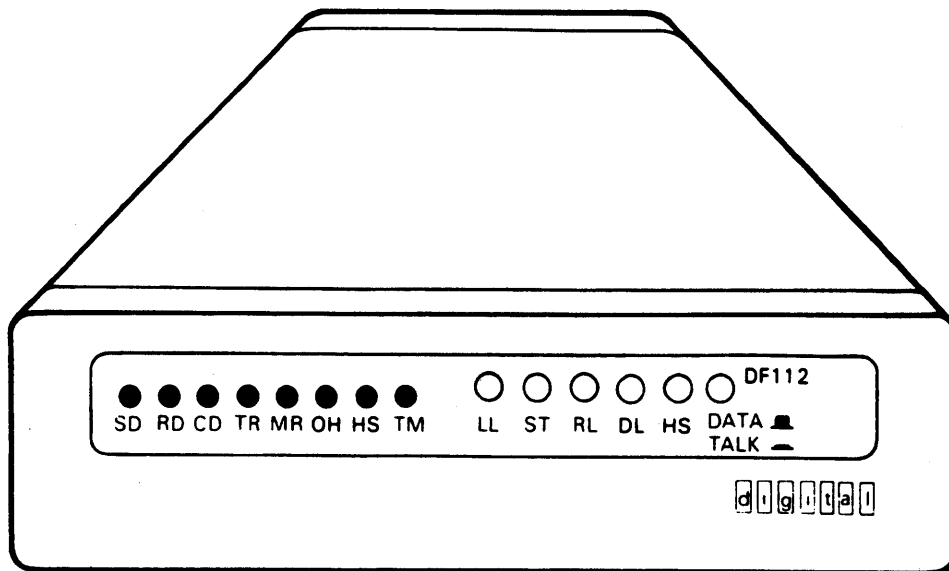

TTB-0376

**Figure A-1 DF112 Modem**

**A.1.1 DF112 Modem Characteristics**

The DF112 modem is the recommended modem to be used with the remote port of the VAX 8820/8830/8840 system (Table A-1). Equivalent modems may be substituted as required.

**A.1.1.1 DF112 Modem General Characteristics**

The DF112 is a 300/1200 bits/s full-duplex, asynchronous/synchronous modem that allows terminals, personal computers, and processors to communicate over dial-up or private/leased telephone lines. The DF112 modem is compatible with Bell 103J/212A™ modems.

The modem can operate at data rates between 0 and 300 bits/s or 1200 bits/s for asynchronous communications and 1200 bits/s for synchronous applications.

**A.1.1.2 Major Features**

Major feature of the DF112 modem include:

- Microprocessor-Controlled Autodialer: Stores up to five 26-digit telephone numbers; compatible with both rotary and tone dialing.
- Extensive Built-In Diagnostics: Help to locate network problems and reduce downtime.
- DATA/TALK Switch: Allows alternate voice/data capability with a standard telephone set.

**Table A-1 DF112 Specifications**

| Characteristic                        | Parameter  |
|---------------------------------------|--|
| Functional Compatibility              | Bell 212A; Bell 103J   |
| Data Format                           | Serial, binary, asynchronous/synchronous data  |
| Operating Mode                        | Auto originate, auto answer, manual originate, manual answer   |
| Communication Mode                    | Full-duplex at all data rates  |
| Data Rate                             | Low-speed: 0-300 bits/s asynchronous<br>High-speed: 1200 bits/s asynchronous/synchronous   |
| Telephone Line Requirement            | Dialup (PSTN)<br>RJ11C (US)/CA11A (Canada)<br>RJ41S (US)/CA41A (Canada)<br>RJ45S (US)/CA45A (Canada)<br>Leased line (P/LTN)<br>625 connection block RJ14 to RJ11 line connection |
| Certified for FCC Part 15 (Subpart J) | For use in home or office environment  |
| Interface Compatibility               | EIA RS-232-C/CCITT V.24 and V.28 compatible voltages   |
| Power Requirements                    | 120 V ac, 60 Hz<br>0.15 A at 5 V dc<br>0.015 A at 12 V dc<br>0.045 A at 12 V dc  |

™ Bell 103J and 212A are registered trademarks of Western Electric

DF112 MODEM INFORMATION

Table A-1 (Cont.) DF112 Specifications

| Characteristic           | Parameter   |
|--------------------------|---|
| Power Requirements       | 120 V ac, 60 Hz<br>0.15 A at 5 V dc<br>0.015 A at 12 V dc<br>0.045 A at 12 V dc |
| Operating Environment    |   |
| Temperature              | 10–40°C (50–104°F)  |
| Relative Humidity        | 0–90% noncondensing, noncaustic   |
| Physical Characteristics |   |
| Height                   | 25.4 mm (1.0 in)  |
| Width                    | 203 mm (8.0 in)   |
| Depth                    | 264 mm (10.4 in)  |
| Weight                   | 0.68 kg (1.5 lb)  |