

THE DRAWING AND SPECIFICATIONS HEREIN ARE THE PROPERTY OF DIGITAL EQUIPMENT CORPORATION AND SHALL NOT BE REPRODUCED OR COPIED OR USED IN WHOLE OR IN PART AS THE BASIS FOR THE MANUFACTURE OR SALE OF ITEMS WITHOUT WRITTEN PERMISSION. COPYRIGHT © 1977 DIGITAL EQUIPMENT CORPORATION.

1-0-77217 M7744-0-1 2

8 7 6 5 4 3 2 1

D
C
B
A

D
C
B
A

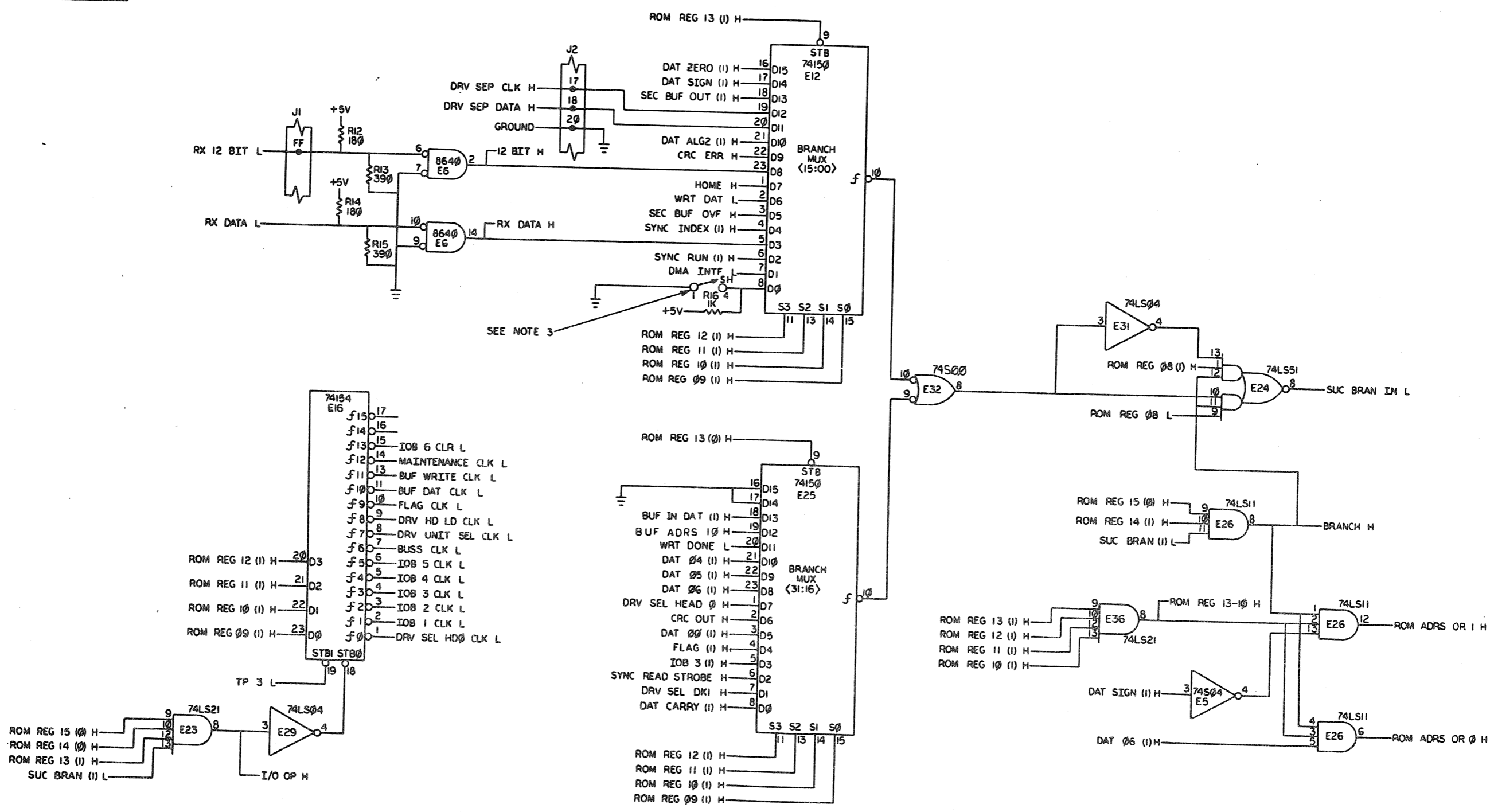

REVISIONS		
CHK	CHANGE NO.	REV.

8	7	6	5	4	3	2	1	
TITLE RX02 FLOPPY DISK CONTROLLER						SIZE CODE DCS	NUMBER M7744-0-1	REV. J
SCALE						SHEET 5 OF 10	DIST.	

21

11C

THE DRAWING AND SPECIFICATIONS HEREIN ARE THE PROPERTY OF METAL EQUIPMENT CORPORATION AND SHALL NOT BE REPRODUCED OR COPIED OR USED IN WHOLE OR IN PART AS THE BASIS FOR THE MANUFACTURE OR SALE OF ITEMS WITHOUT WRITTEN PERMISSION. COPYRIGHT © 1977 METAL EQUIPMENT CORPORATION

C 1-0-bb22W 2

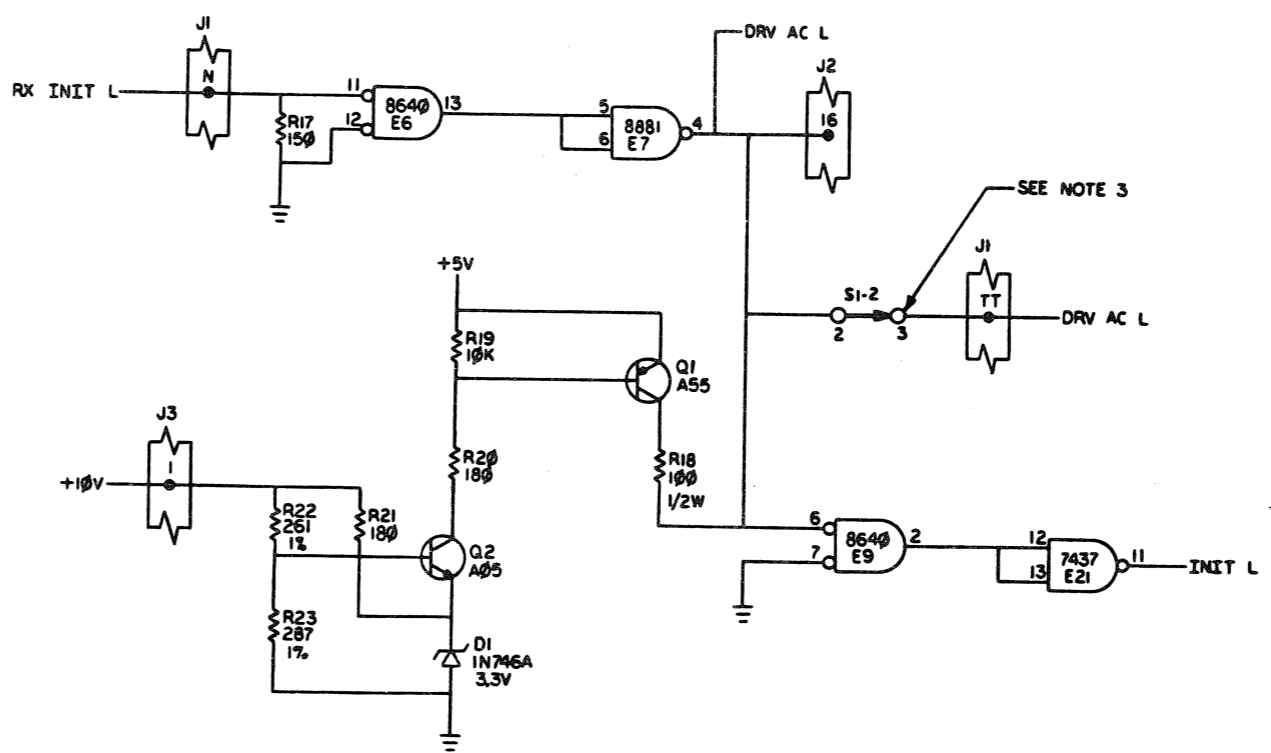
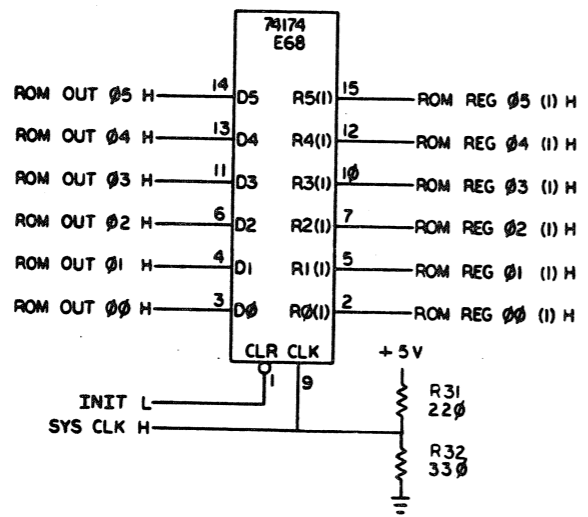
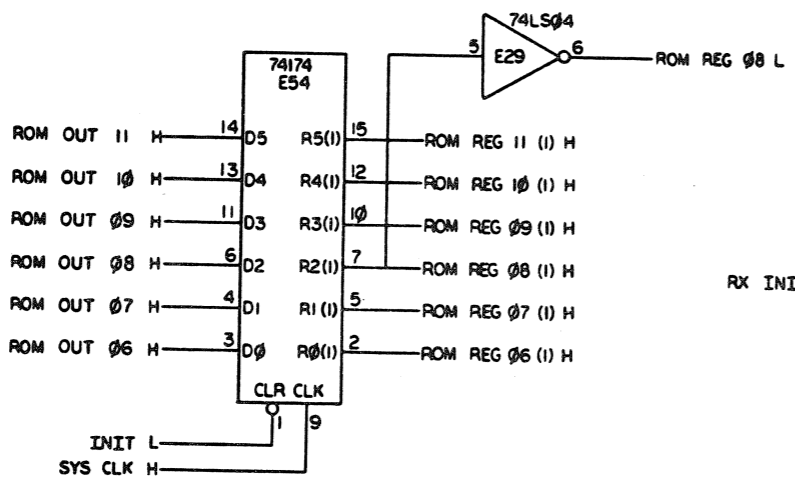
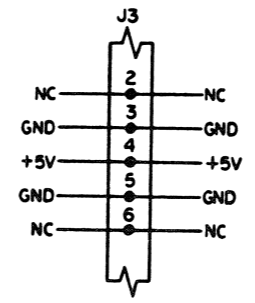
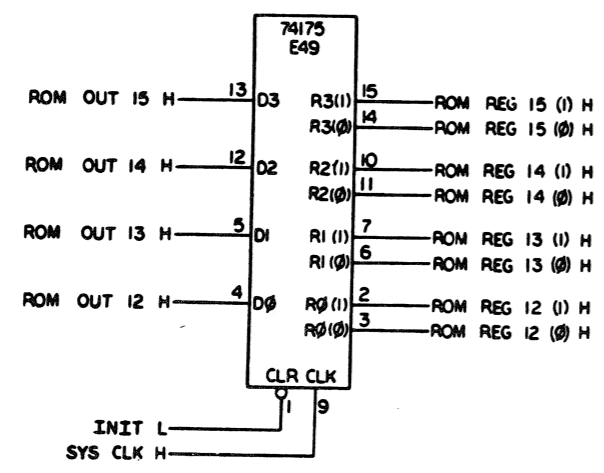

REVISIONS		
CHK	CHANGE NO.	REV.

TITLE RX02 FLOPPY DISK CONTROLLER
 SCALE 1/1 SHEET 6 OF 10
 NUMBER DCS M7744-01
 REV. J

"THE DRAWING AND SPECIFICATIONS HEREIN ARE THE PROPERTY OF DIGITAL EQUIPMENT CORPORATION AND SHALL NOT BE REPRODUCED OR COPIED OR USED IN WHOLE OR IN PART AS THE BASIS FOR THE MANUFACTURE OR SALE OF ITEMS WITHOUT WRITTEN PERMISSION. COPYRIGHT © 1977 DIGITAL EQUIPMENT CORPORATION"

10-07211W DCS 2

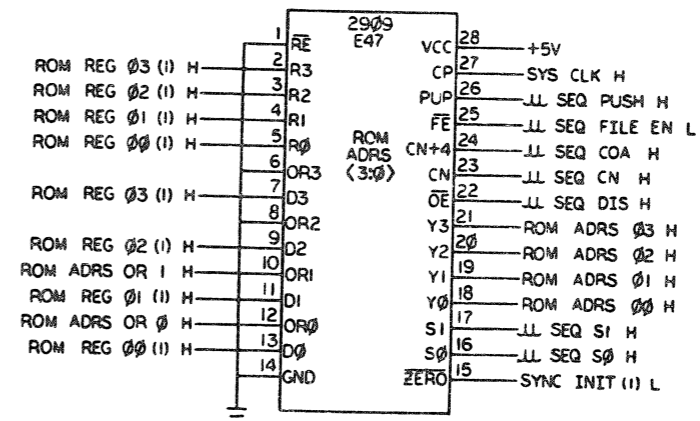
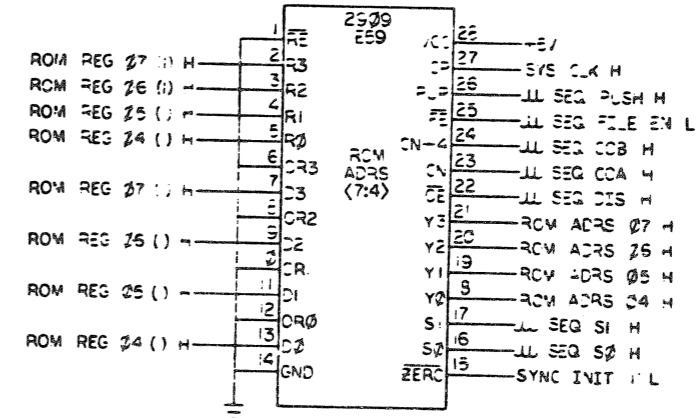
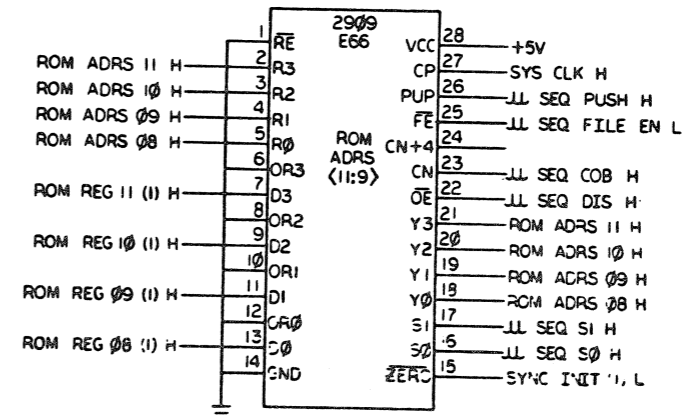
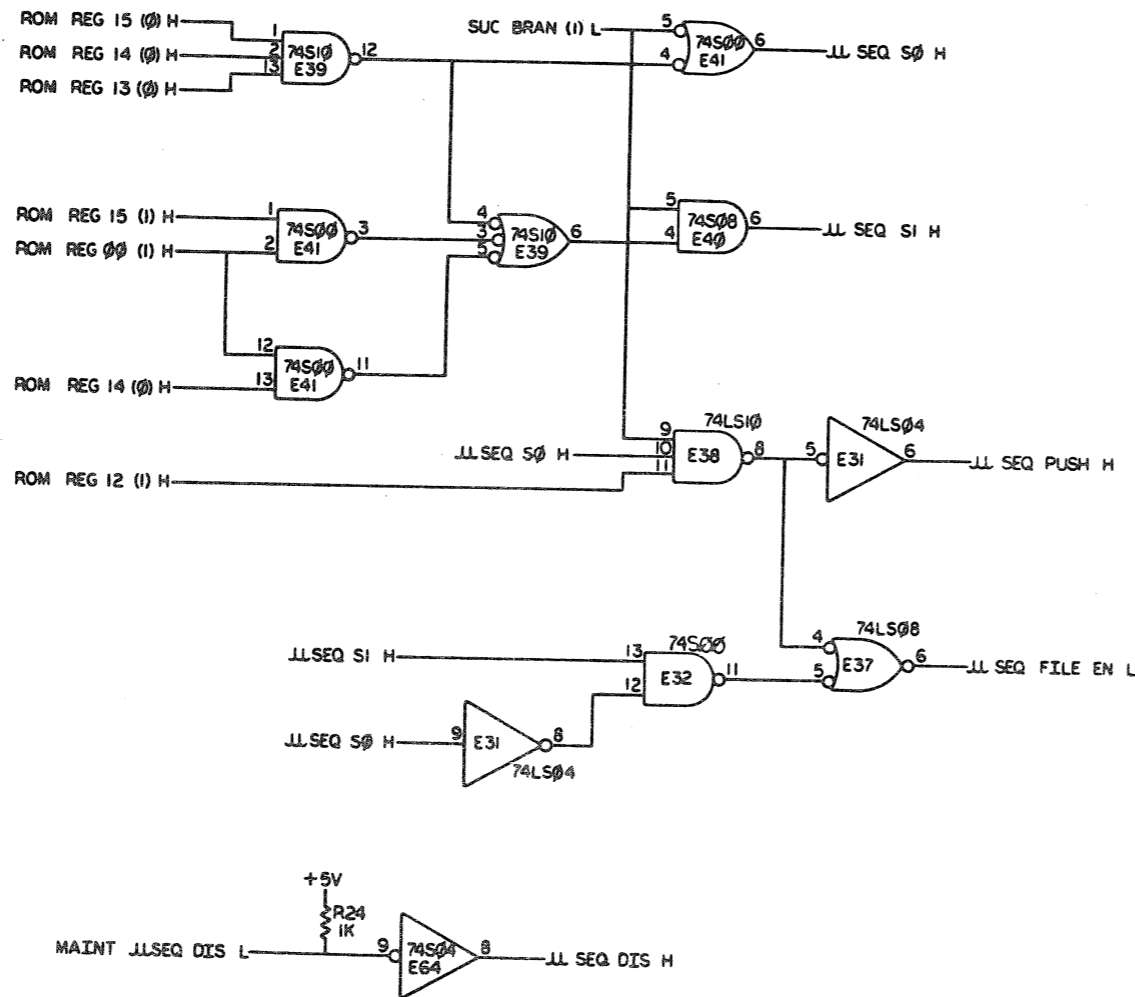

REVISIONS		
CHK	CHANGE NO.	REV.

TITLE RX02 FLOPPY DISK CONTROLLER
 SIZE CODE DCS NUMBER M7744-01 REV. J
 SCALE 1/16" = 1" SHEET 7 OF 10 DIST.

23

REV. J NUMBER M7744-01

THE DRAWING AND SPECIFICATIONS HEREIN ARE THE PROPERTY OF DIGITAL EQUIPMENT CORPORATION AND SHALL NOT BE REPRODUCED OR COPIED OR USED IN WHOLE OR IN PART AS THE BASIS FOR THE MANUFACTURE OR SALE OF ITEMS WITHOUT WRITTEN PERMISSION. COPYRIGHT © 1977 DIGITAL EQUIPMENT CORPORATION

CS M7744-01 2

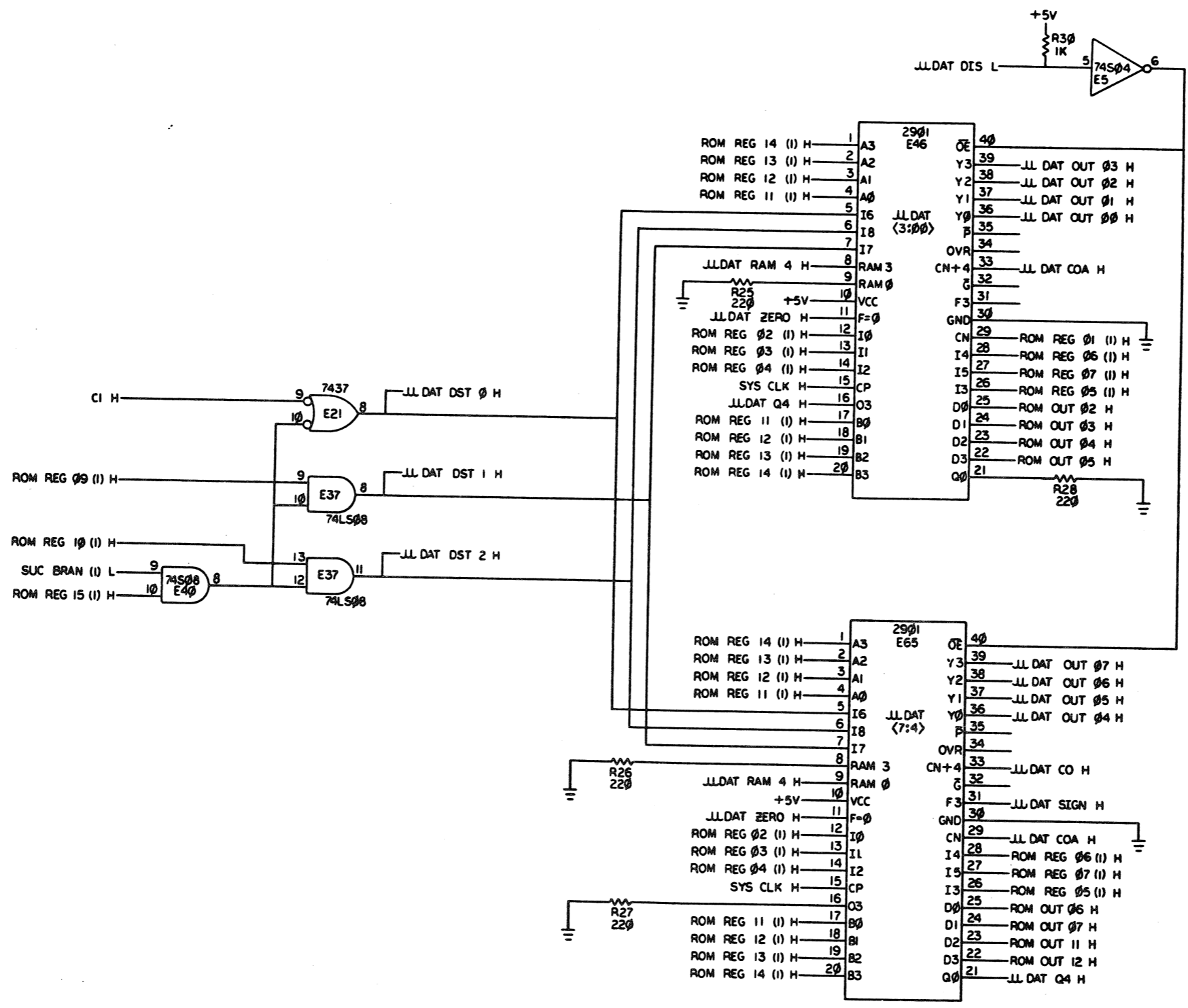

REVISIONS		
CHK	CHANGE NO.	REV.

TITLE RX02 FLOPPY DISK CONTROLLER
 SIZE CODE U CS
 NUMBER M7744-01
 REV. J
 SCALE 1/16
 SHEET 8 OF 10
 DATE

CS M7744-01 J

"THIS DRAWING AND SPECIFICATIONS HEREIN ARE THE PROPERTY OF DIGITAL EQUIPMENT CORPORATION AND SHALL NOT BE REPRODUCED OR COPIED OR USED IN WHOLE OR IN PART AS THE BASIS FOR THE MANUFACTURE OR SALE OF ITEMS WITHOUT WRITTEN PERMISSION. COPYRIGHT © 1977 DIGITAL EQUIPMENT CORPORATION"

CS M7744-01 2

D
C
B
A

D
C
B
A

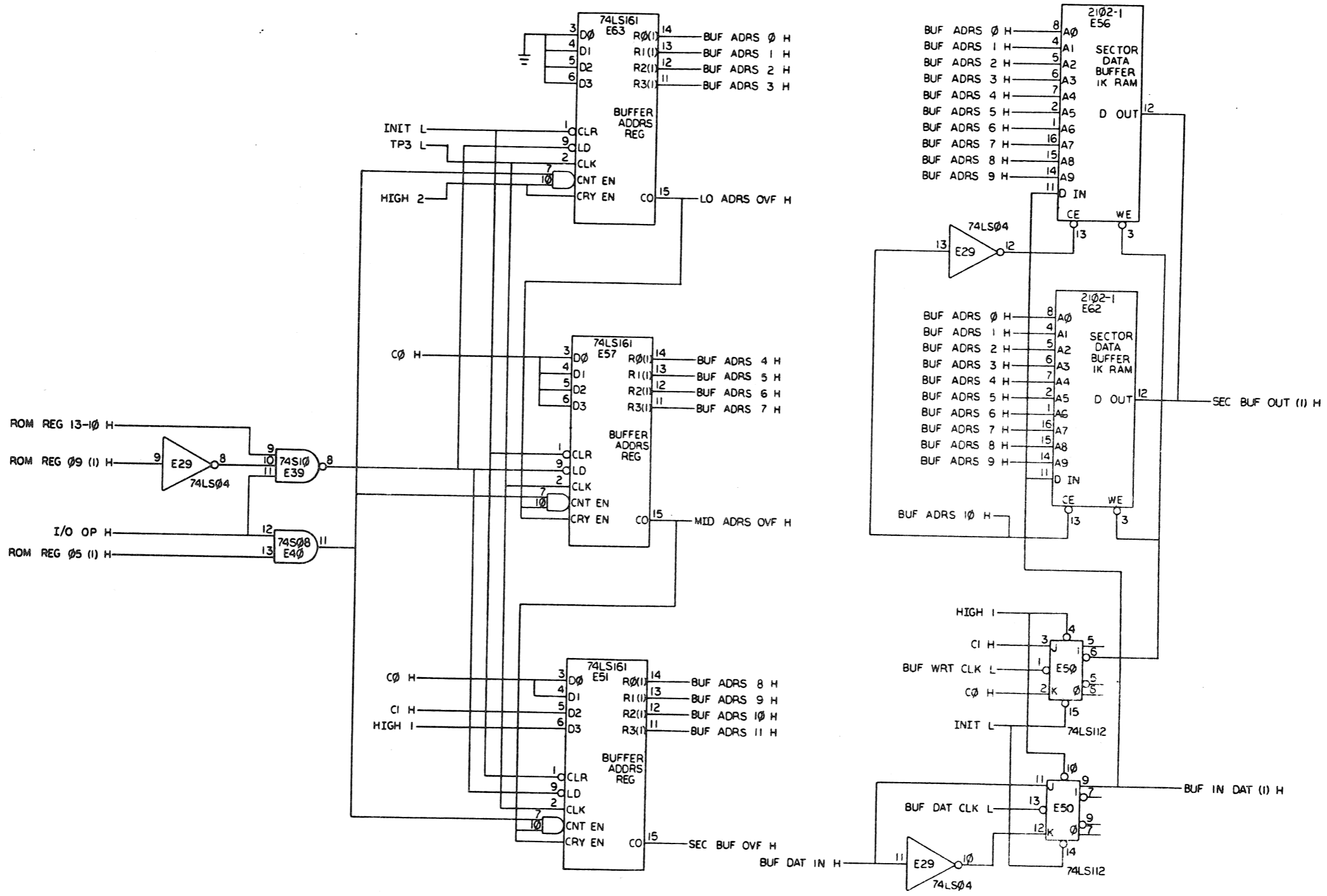

REVISIONS		
CHK	CHANGE NO.	REV.

DEC FORM NO. 110 120

TITLE RX02 FLOPPY DISK CONTROLLER
 SIZE CODE DCS
 NUMBER M7744-01
 REV. J
 SCALE 1/16" = 1" SHEET 9 OF 10 DIST.

THIS DRAWING AND SPECIFICATIONS HEREIN ARE THE PROPERTY OF DIGITAL EQUIPMENT CORPORATION AND SHALL NOT BE REPRODUCED OR COPIED OR USED IN WHOLE OR IN PART AS THE BASIS FOR THE MANUFACTURE OR SALE OF ITEMS WITHOUT WRITTEN PERMISSION. COPYRIGHT © 1977 DIGITAL EQUIPMENT CORPORATION

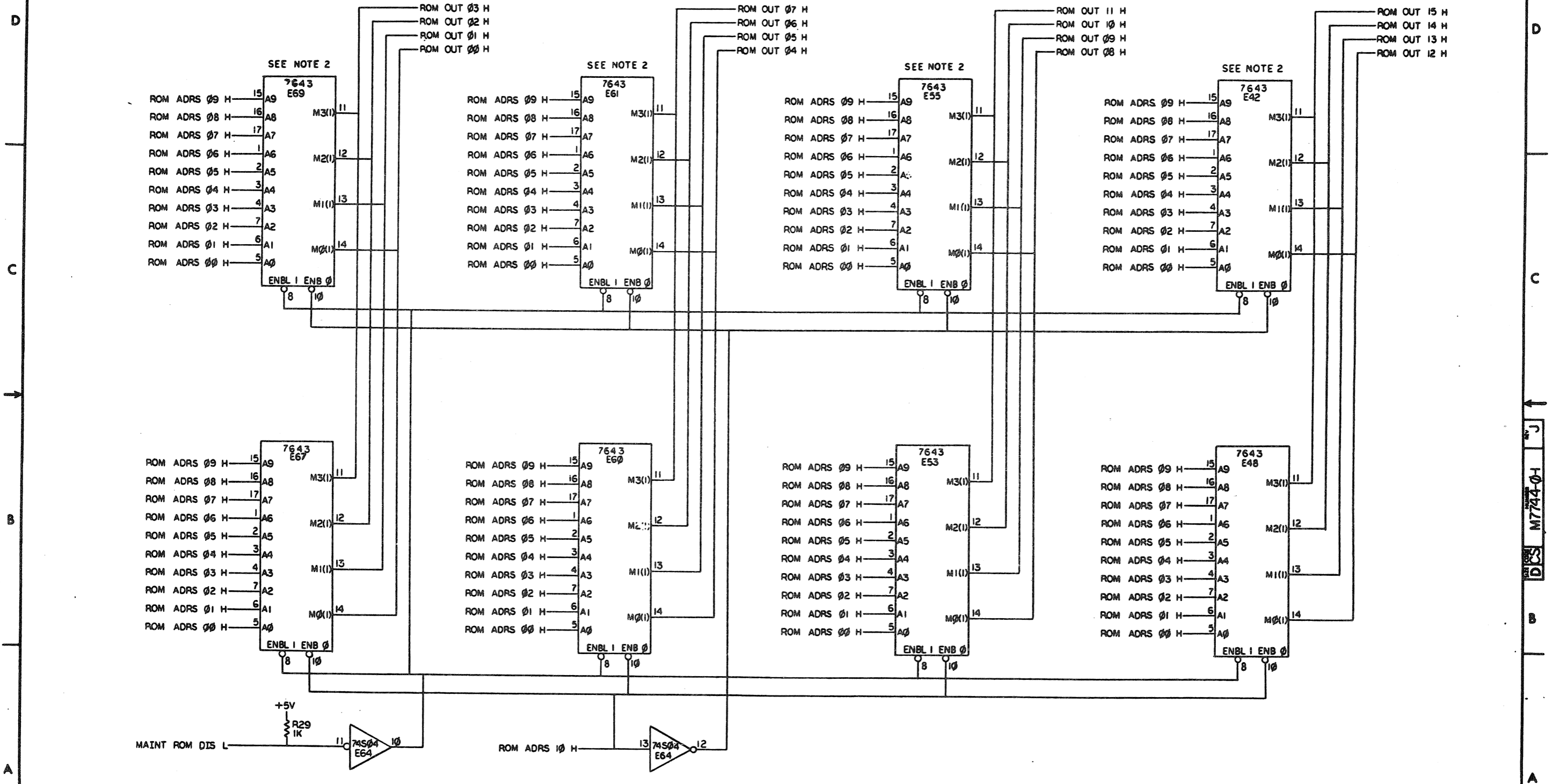

REVISIONS		
CHK	CHANGE NO.	REV.

TITLE	RX02 FLOPPY DISK CONTROLLER	SIZE/COOR	DCS	NUMBER	M7744-01	REV.	J
SCALE	1/1	SHEET	10	OF	10	DIST.	

DCS M7744-01

THIS DRAWING AND SPECIFICATIONS, HEREIN, ARE THE PROPERTY OF DIGITAL EQUIPMENT CORPORATION AND SHALL NOT BE REPRODUCED OR COPIED IN WHOLE OR IN PART OR IN ANY MANNER FOR THE PERFORMANCE OR SALE OF ITEMS WITHOUT WRITTEN PERMISSION.
COPYRIGHT © 1970 DIGITAL EQUIPMENT CORPORATION

0-0-S-77W 2 1

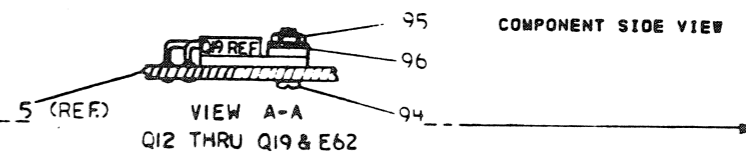

15.69 REF

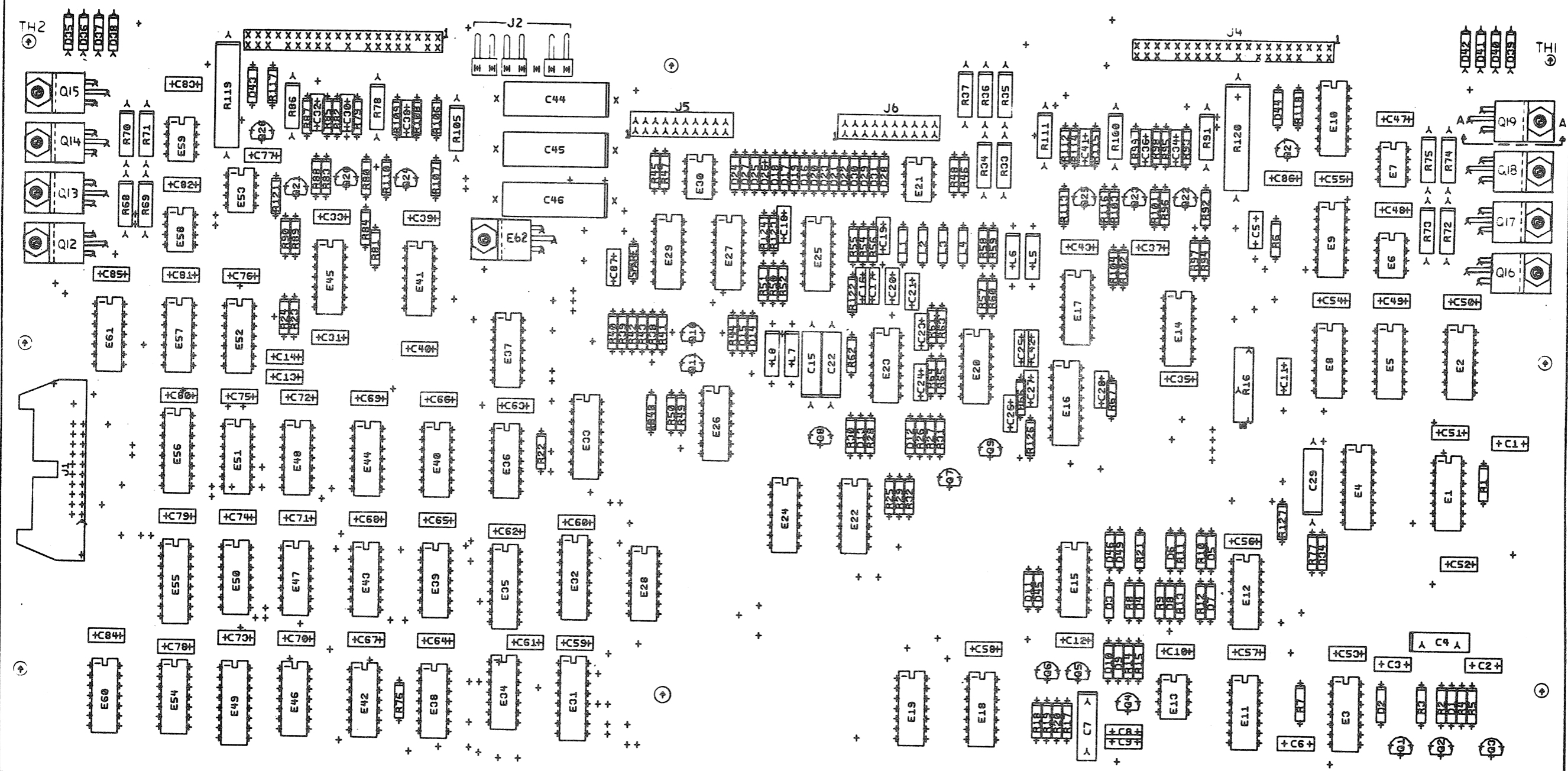

7.95 REF

NOTES:

STEP 2	→ Y AXIS	STEP	TIMES
REPEAT	→ X AXIS	STEP	TIMES

CHG	CHANGE NO	REV
REDAWN	J	
M7745-		
ML007		

ETCH REV. F-P2

SIGNATURES	DATE
DRN. <i>[Signature]</i>	4-24-70
CHK'D. <i>[Signature]</i>	5-28-70
MECH. ENG. <i>[Signature]</i>	7-24-70
PROJ. ENG. <i>[Signature]</i>	7-24-70
SCALE 2/1	
SHT. OF	
NEXT HIGHER ASSY. B-DD-M7745-0	

digital	
TITLE RX02 R/W CONTROL	
SIZE CODE	NUMBER
0 UA	M7745-0-0
REV	J

1 MS# 264592

LINE ITEM	DOCUMENT NUMBER	PART NUMBER	DESCRIPTION	QTY PER VARIATION	REFERENCE DESIGNATOR
				00	
1	5	D-MD-5012956-0-0	5012956-00	RX02	1
2	6		1005820-00	22.0 MMF 100V 5%200PFM MICA	2
3	7		1000016-00	100.0 MMF 100V 5%200PFM MICA	1
4	8		1000020-00	180.0 MMF 100V 5%200PFM MICA	8
5	9		1001383-00	4700.0 MMF 100V 3%200PFM MICA	1
6	10		1000042-00	1000.0 MMF 100V 5%200PFM MICA	1
7	11		1000026-00	680.0 MMF 100V 5%200PFM MICA	1
8	12		1012084-01	8 MFD 25V +75-10% AL EL	1
9	13		1009433-00	190 MFD 12V +75-10% AL EL	2
10	14		1000080-00	50 MFD 50V +75-10% AL EL	1
11	15		1001610-00	.01 MFD 50V +80-20% 25U CER	52
12	16		1010978-32	.047 MFD 50V 10% CER	4
13	17		1001765-00	.005 MFD 100V 20% Z5T DISC	6
14	18		1000050-00	.033 MFD 100V 10% MYLR	2
15	19		1010274-02	1 MFD 50V +80-20% CER	1
16	21		1000015-00	82.0 MMF 100V 5%200PFM MICA	1
17	22		1103309-00	D 671 TR= 6NS PIV= 50V SI	8
18	23		1105275-00	D 672 TR= 15NS PIV= 60V SI	24
19	24		1105796-00	1N 4004 PIV=400 I= 1A D041 SP	10
20	25		1110713-00	SZ710910 VZ= 5.1 2% M	3
21	26		1101938-00	1N 4370A VZ= 2.4 3% .40W	1
22	27		1610033-00	DELAY= 10-100NS,10TAPS	1
23	28		1602723-00	1000 UH 10% 125MA	4
24	29		1612946-02	22 UH 10%	2
25	30		1610661-00	56 UH 10% #DD56	2
26	31		1510705-00	XA 05 NPN 500MW SI 60 50 P	8
27	32		1510706-00	XA 55 PNP 500MW SI 60 50 P	5

REVISION HISTORY		BASIC PART NO:	M7745		DRN:	P. KENDRICK	DATE:	06-JAN-78				DIGITAL			
ENG	ECD NUMBER	REV	SECTION A	OF A	CHK'D:	A. ANDERSON	DATE:	06-JAN-78				TITLE PARTS LIST			
---	INIT	A	SECTION VARIATION INDEX		CHK'D:	A. ANDERSON	DATE:	06-JAN-78				TITLE PARTS LIST			
GM	00001	B	[A]	00								RX02 R/W CONTROL			
ER	ML002	C	[B]												
C.Y.	M7745-ML003	D	[C]		DES.ENG:	A. ANDERSON	DATE:	05-APR-78							
C.Y.	M7745-ML004	E	[D]												
JG	M7745-ML005	F	[E]									DOCUMENT NUMBER			
AA	M7745-ML006	H	[F]		RESP.ENG.:	J. GLAVIN	DATE:	05-APR-78							
D.P.	M7745-ML007	J	[G]									SIZE CODE NUMBER REV			
			[H]		MFG.ENG.:	J. MONCHELLI	DATE:	05-APR-78				K	PL	M7745-0-DBP	J
			[I]		ASSEMBLY NUMBER:		TOP DOCUMENT NUMBER:					FILE NAME: EDIT #			
			[J]		D-LA-M7745-0-0		#B-DD-M7745-0					Z0192J.PLS 56			

* THIS DRAWING AND SPECIFICATIONS HEREIN, ARE THE PROPERTY OF DIGITAL EQUIPMENT CORPORATION AND SHALL NOT BE REPRODUCED OR COPIED OR USED IN WHOLE OR IN PART AS THE BASIS FOR THE MANUFACTURE OR SALE OF ITEMS WITHOUT WRITTEN PERMISSION. COPYRIGHT (C) 1981. DIGITAL EQUIPMENT CORPORATION *

LINE	ITEM	DOCUMENT NUMBER	PART NUMBER	DESCRIPTION	QTY	PER VARIATION	REFERENCE DESIGNATOR
					00		
28	33		1503409-00	DEC6534D PNP 310MW SI 40 90	4		Q1,Q2,Q5,Q6
29	34		1501999-00	DEC3009A NPN 300MW SI 20 25 M	1		Q3
30	35		1510233-00	2N 5460 FET 310MW SIP CHNNL	1		Q4
31	36		1510421-00	D 44CB NPN 30WT SI 60 20	8		Q12-Q19
32	37		1912799-00	LS00 NAND-GATE-QUAD 2IN,P	2		E19,E39
33	38		1912801-00	LS02 NOR-GATE-QUAD 2IN	2		E9,E60
34	39		1912803-00	6SD4 INVERTER GATE,HFL	3		E3,E26,E52
35	40		1910741-00	7406 INVERTER GATE-HEX 1I	1		E22
36	41		1912805-00	LS08 AND GATE-QUAD 2IN,PO	7		E5,E10,E24,E29,E38,E46,E57
37	42		1909929-00	7417 BUFFER GATE-HEX 1INP	2		E18,E34
38	43		1912816-00	LS32 OR GATE-QUAD 2IN,FOS	4		E1,E36,E47,E54
39	44		1905580-00	DEC 7450 A-0-I XPNDBLE GATE-D	1		E8
40	45		1912823-00	LS73 FF-JK DUAL W/CLEAR	2		E2,E61
41	46		1912824-00	LS74 FF-D DUAL,EDGE TRIGG	8		E11,E12,E40,E42-E44,E48,E50
42	47		1912837-00	LS123 ONE SHOT-DUAL,RETRIG	1		E16
43	48		1912697-00	LS174 FF-D HEX W/CLEAR	1		E55
44	49		1912854-00	LS193 COUNTER,SYNCHR,4BIT,	4		E31,E32,E35,E49
45	50		1910268-00	DEC 75107B RECEIVER,LINE,DUAL,	1		E15
46	51		1910406-00	75451 DRIVER,PERIPH,DUAL,	5		E6,E7,E53,E58,E59
47	52		1910645-00	75452 DRIVER,PERIPH,DUAL,	2		E21,E30
48	53		1910735-02	318 OP AMP	1		E13
49	54		1910337-00	DEC 1414L VOLT COMPARATOR,DUAL	5		E14,E17,E20,E41,E45
50	55		1910644-00	733 DIFFERENTIAL AMP,WID	2		E23,E25
51	56		2113632-00	4066B BILATERAL SWITCH-QUA	1		E27
52	57		1912845-00	LS153 MUX 1 OF 4 (DUAL)	1		E56
53	58		1912048-02	DEC 7812 VOLT REG,FIX +12V	1		E62
54	59		1309405-00	68.0 .50 W 5.0 % CC	6		R78,R86,R91,R100,R105,R111
55	60		1304837-00	24.0 K .25 W 5.0 % CC	4		R49,R52,R8,R13
56	61		1301425-00	300.0 .25 W 5.0 % CC	1		R76
57	62		1312931-00	6.20 K .25 W 5.0 % CC	2		R9,R11
58	63		1300271-00	220.0 .25 W 5.0 % CC	1		R22
59	65		1313590-00	1.50 K .25 W 1.0 % RN55D-F10	2		R57,R60
60	66		1302874-00	147.0 .25 W 1.0 % RN55D-F10	4		R54,R56,R58,R59
61	67		1302377-00	39.0 .25 W 5.0 % CC	1		R55
62	68		1301890-00	560.0 .25 W 5.0 % CC	1		R21
63	69		1300316-00	470.0 .25 W 5.0 % CC	5		R1,R6,R7,R23,R24
64	70		1300365-00	1.0 K .25 W 5.0 % CC	11		R2,R5,R10,R42,R43,R61,R63,R117, CONT R118,R31,R127
65	71		1302871-00	1.21 K .25 W 1.0 % RN55D-F10	5		R106,R110,R112,R116,R27
66	72		1300391-00	1.50 K .25 W 5.0 % CC	9		R38,R41,R83,R88,R96,R101,R109, CONT R115,R62
67	73		1302388-00	2.0 K .25 W 5.0 % CC	3		R19,R20,R50
68	74		1304868-00	2.74 K .25 W 1.0 % RN55D-F10	1		R30
69	75		1302389-00	4.30 K .25 W 5.0 % CC	2		R3,R4
70	76		1304856-00	4.64 K .25 W 1.0 % RN55D-F10	6		R80,R92,R103,R107,R113,R121
71	78		1300479-00	10.0 K .25 W 5.0 % CC	12		R12,R14,R26,R28,R45-R48,R79,R87, CONT R93,R99
72	79		1302941-00	14.70 K .25 W 1.0 % RN55D-F10	8		R81,R84,R89,R90,R94,R97,R102,

D	I	G	I	T	A	L	TITLE	SECTION A OF A	SIZE	CODE	DOCUMENT NUMBER	REV
							RX02 R/W CONTROL		K	PL	M7745-0-DBP	J