

THIS SHEET AND SPECIFICATIONS, DRAWING AND THE PROPERTY OF ALLIED SIGNAL COMPANY AND SHALL NOT BE REPRODUCED OR COPIED IN WHOLE OR IN PART ON THE BASIS OF THE INFORMATION ON THIS SHEET WITHOUT WRITTEN PERMISSION.

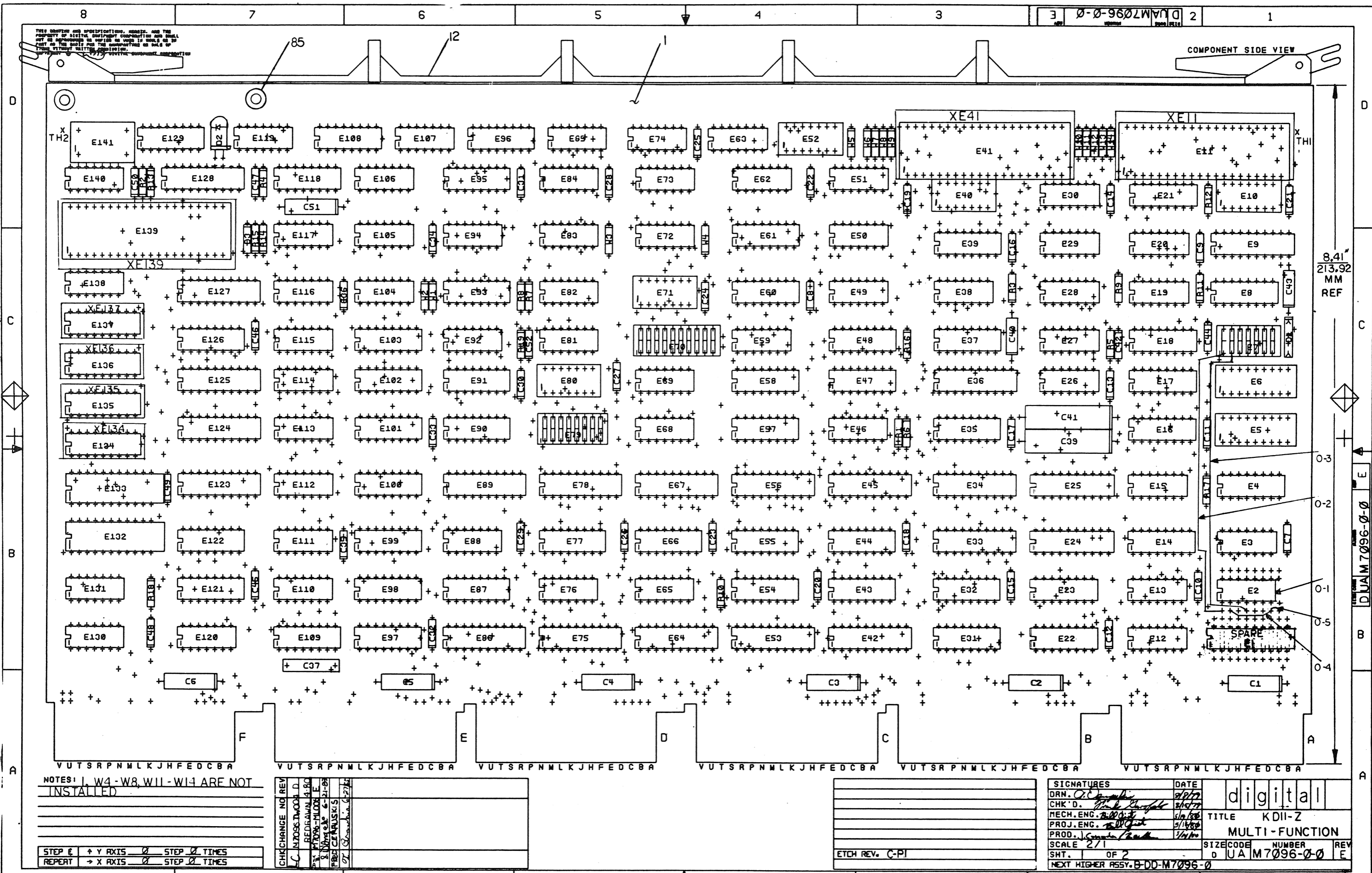

8.41" 213.92 MM REF

D U A M 7 0 9 6 - 0 - 0

NOTES: 1. W4 - W8, W11 - W14 ARE NOT INSTALLED

STEP E + Y AXIS 0 STEP 0 TIMES  
 REPEAT -> X AXIS 0 STEP 0 TIMES

CHK	CHANGE NO	REV	DATE	BY	REASON
C	1	1	1/17/77	...	...

ETCH REV. C-PI
----------------

SIGNATURES	DATE	digital
DRN. C.C. ...	1/17/77	
CHK'D. ...	1/17/77	TITLE KDI-Z
MECH. ENG. ...	1/17/77	MULTI-FUNCTION
PROJ. ENG. ...	1/17/77	SCALE 2/1
PROD. J. ...	1/17/77	SHT. OF 2
		SIZE CODE NUMBER
		0 U A M 7 0 9 6 - 0 - 0
		REV E
		NEXT HIGHER ASSY. B-DD-M7096-0

THIS DRAWING AND SPECIFICATIONS HEREIN ARE THE PROPERTY OF DIGITAL EQUIPMENT CORPORATION AND SHALL NOT BE REPRODUCED OR COPIED OR USED IN WHOLE OR IN PART AS THE BASIS FOR THE MANUFACTURE OR SALE OF ITEMS WITHOUT WRITTEN PERMISSION.  
 COPYRIGHT © 1980 DIGITAL EQUIPMENT CORPORATION

REV. 2-0-8607W 2

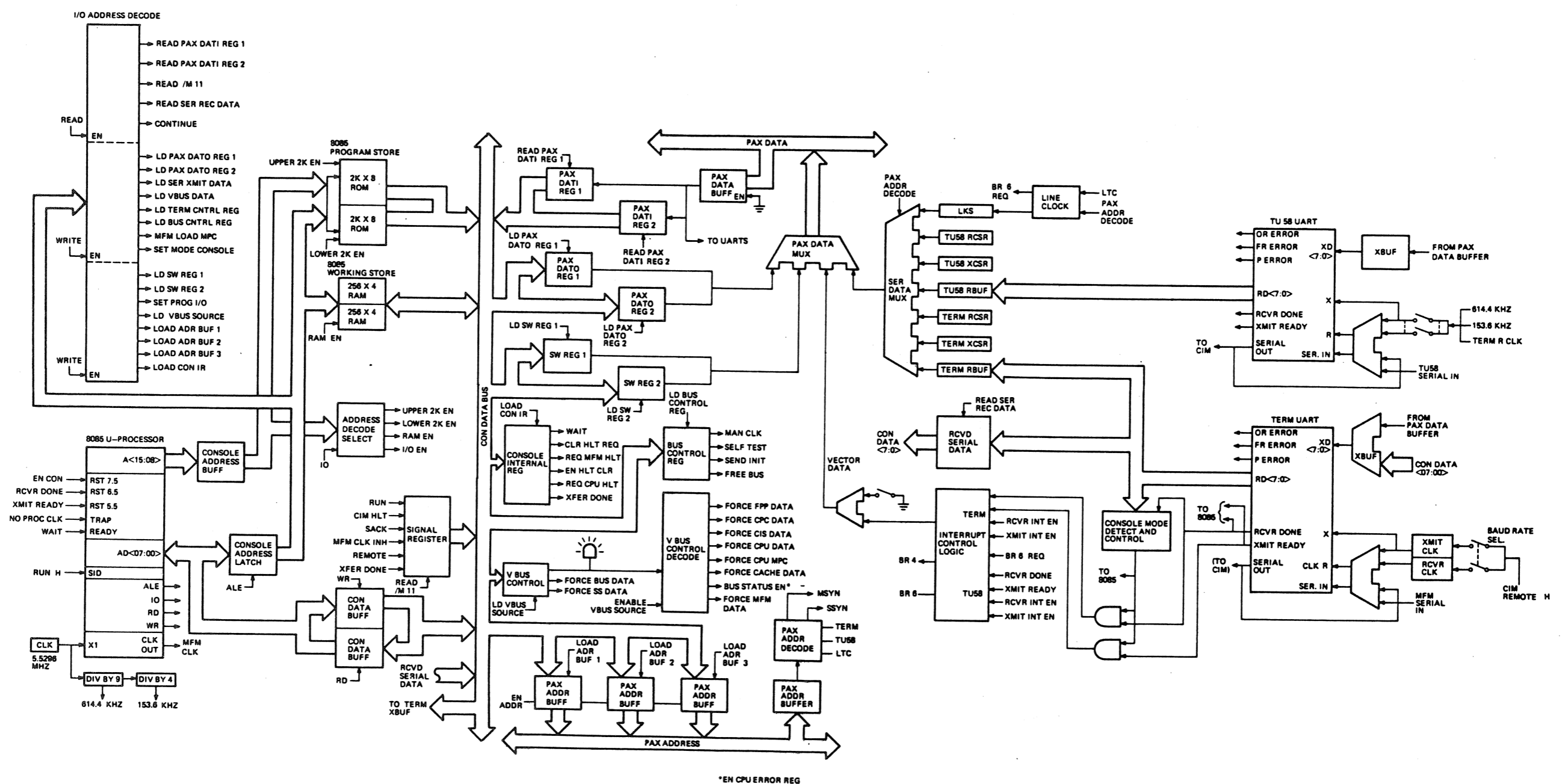

REV. A	ORIG.
CHK	CHG
REV. A	CHG

DRN. S. Sharp	17-APR-80	FIRST USED ON	PDP-11/44	digital
CHK'D B. Galt	7-APR-80	TITLE	MULTI-FUNCTION MODULE	
ENG. B. Galt	7-APR-80	PROJ. ENG. B. Galt	PROD. B. Galt	7-APR-80
NEXT HIGHER ASSY.				
B-DD-KD11-2-0	SIZE	CODE	NUMBER	REV.
SCALE NONE	D	BD	M7096-0-2	A
SHEET 1	OF 1	DIST.		

REV. E	SIZE D	CODE CS	NUMBER 1-8-96/1	REV. 3	3	4	5	6	7	8	
TITLE: (K3-1) MULTI-FUNCTION MODULE				FIRST USED ON OPTION/MODEL: 11/44				REV. 4			
B-DD-W7096-0				NEXT HIGHER ASSEMBLY: 17-OCT-79 18:28				REV. 5			
DATE: 11-MAR-88				CHK. D. [Signature]				REV. 6			
DATE: 23-OCT-79				CHK. D. [Signature]				REV. 7			
DATE: 08-SEP-87				CHK. D. [Signature]				REV. 8			
DATE: 08-SEP-87				CHK. D. [Signature]				REV. 9			
DATE: 08-SEP-87				CHK. D. [Signature]				REV. 10			

NOTE: SEE PAGES K3-5, K3-8, AND K3-10 FOR JUMPER AND SWITCH DEFINITIONS

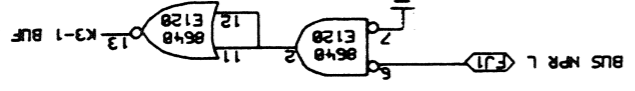
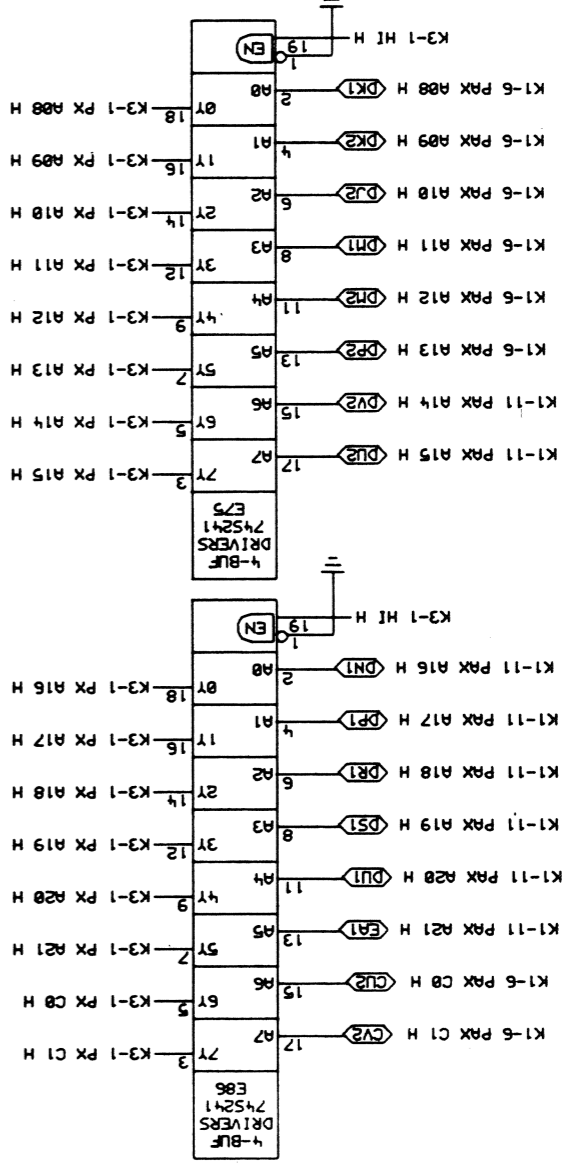
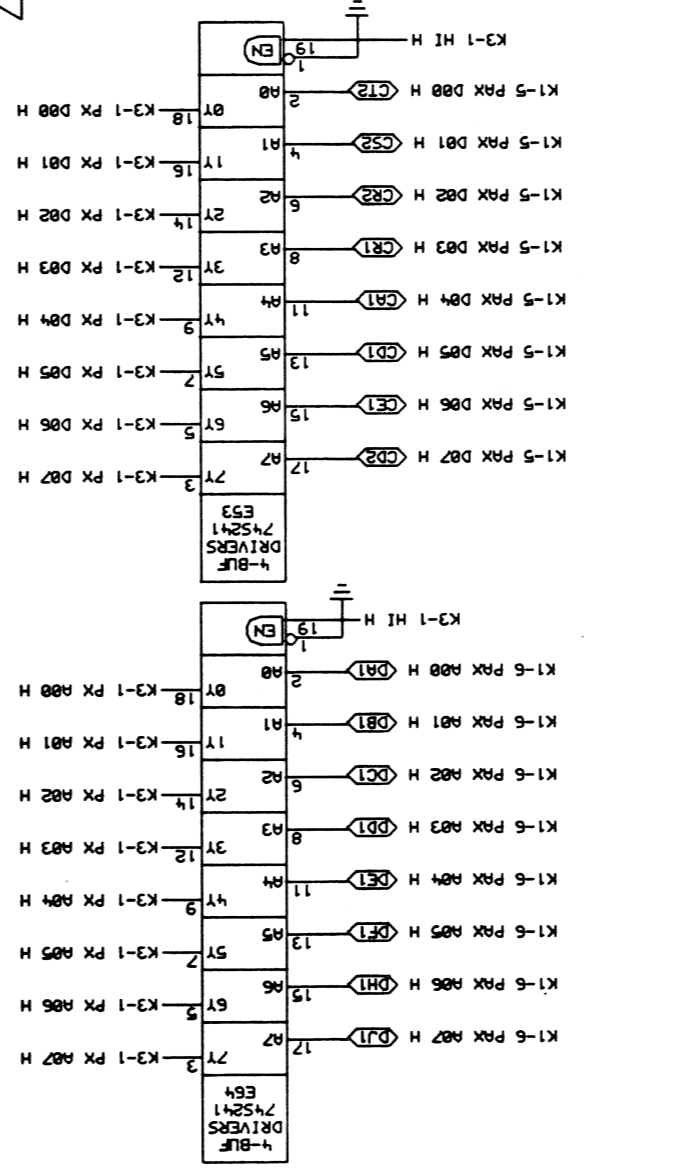
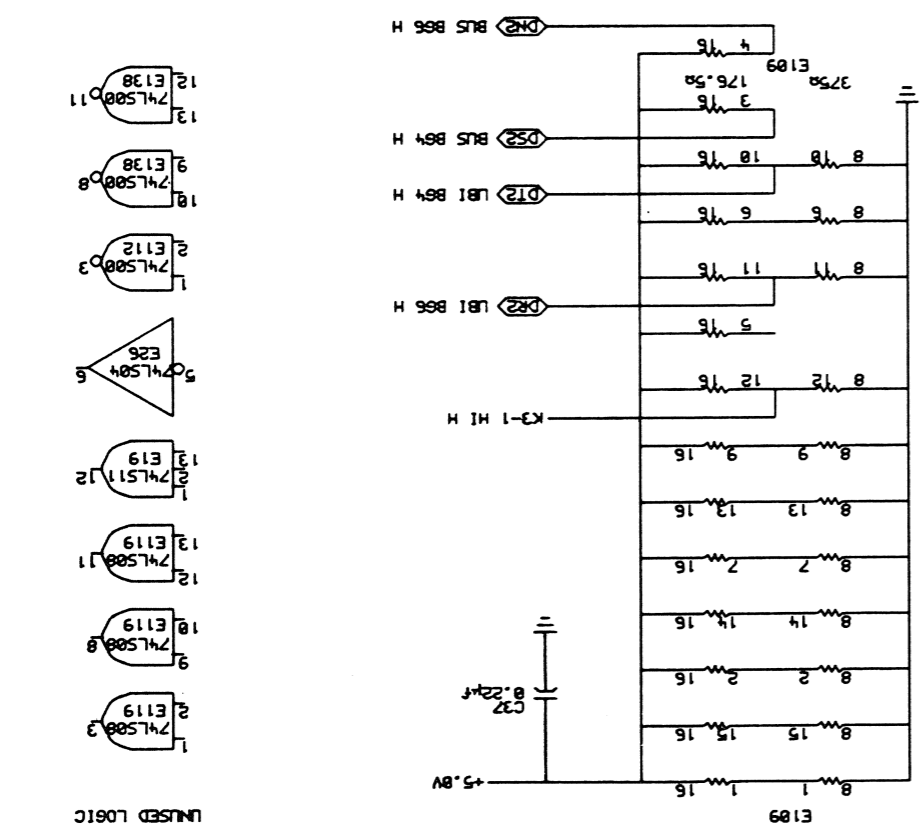
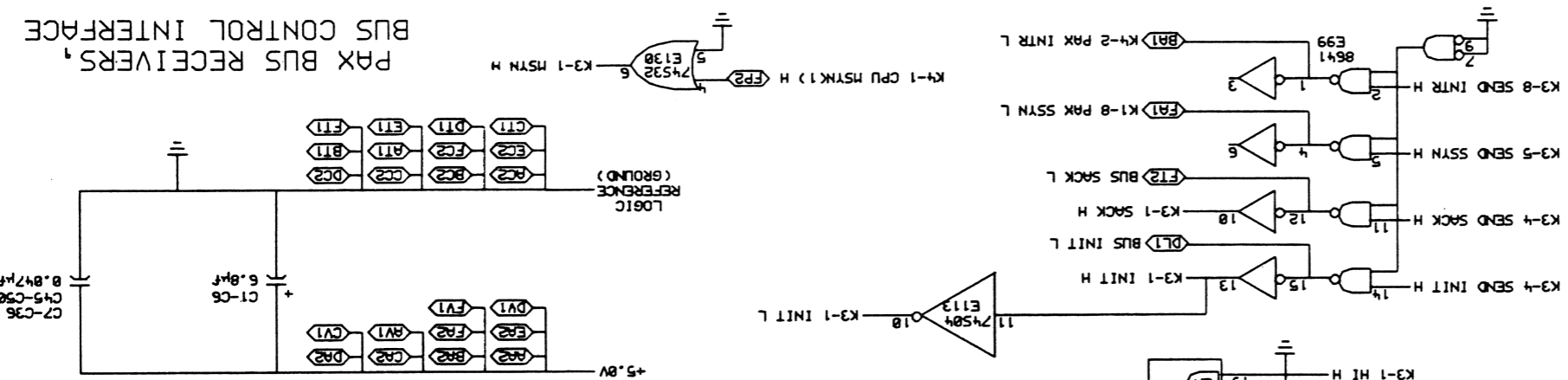

REV. 3	SIZE D	CODE CS	NUMBER 1-8-96/1	REV. 3	3	4	5	6	7	8
--------	--------	---------	-----------------	--------	---	---	---	---	---	---







REV.	CHK	CHANGE NO.	REV.

THIS DRAWING HAS 2-1/2 CONNECTIONS  
 DIGITAL EQUIPMENT COMPANY  
 DIGITAL EQUIPMENT COMPANY  
 SHALL NOT BE REPRODUCED OR COPIED  
 IN ANY MANNER WITHOUT THE WRITTEN  
 PERMISSION OF THE MANUFACTURER  
 THE PARTS FOR THE MANUFACTURE OF  
 THIS EQUIPMENT MUST BE ORDERED FROM  
 THE MANUFACTURER OR ITS AUTHORIZED  
 DISTRIBUTOR

# PAX ADDRESS DECODE

NOTE: ADDRESS BITS 0 THROUGH 2 ARE "0" IN THE BASE ADDRESS.  
 ADDRESS BITS 13 THROUGH 21 ARE ALL "1" IN THE BASE ADDRESS.  
 THESE BITS HAVE NO CORRESPONDING SWITCH.

BUS ADDRESS BIT #	21	20	19	18	17	16	15	14	13	12	11	10	9	8	7	6	5	4	3	2	1	0
SWITCH SETTING	1	1	1	1	1	1	1	1	1	1	1	1	1	1	1	1	1	1	1	1	1	1
OCTAL ADDRESS	1	1	1	1	1	1	1	1	1	1	1	1	1	1	1	1	1	1	1	1	1	1

EXAMPLE: SET TUS8 ADDRESS TO 1776900K8:  
 BUS ADDRESS BIT # 12 11 10 9 8 7 6 5 4 3  
 SWITCH #E70- 1 2 3 4 5 6 7 8 9 10

E70-1 THROUGH E70-10 SELECT THE BASE ADDRESS FOR THE TUS8 FROM 1776000K8) TO 1777777K8). IN SETTING E70, NOTE THAT A SWITCH IS CLOSED (ON) FOR A "1", AND OPEN (OFF) FOR A "0". THE FOLLOWING CHART SHOWS EACH SWITCH NUMBER AND ITS CORRESPONDING BUS ADDRESS BIT NUMBER.

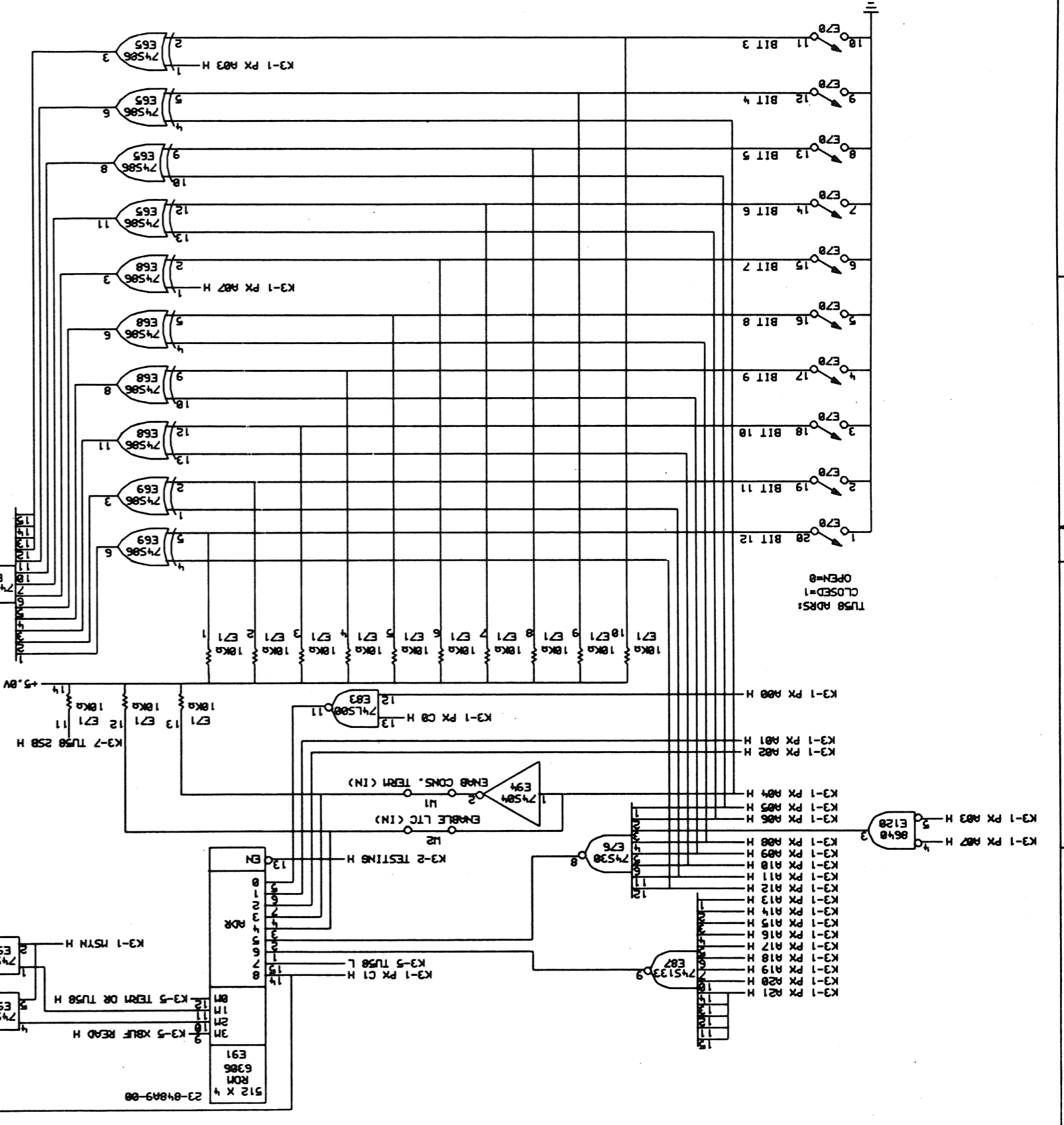
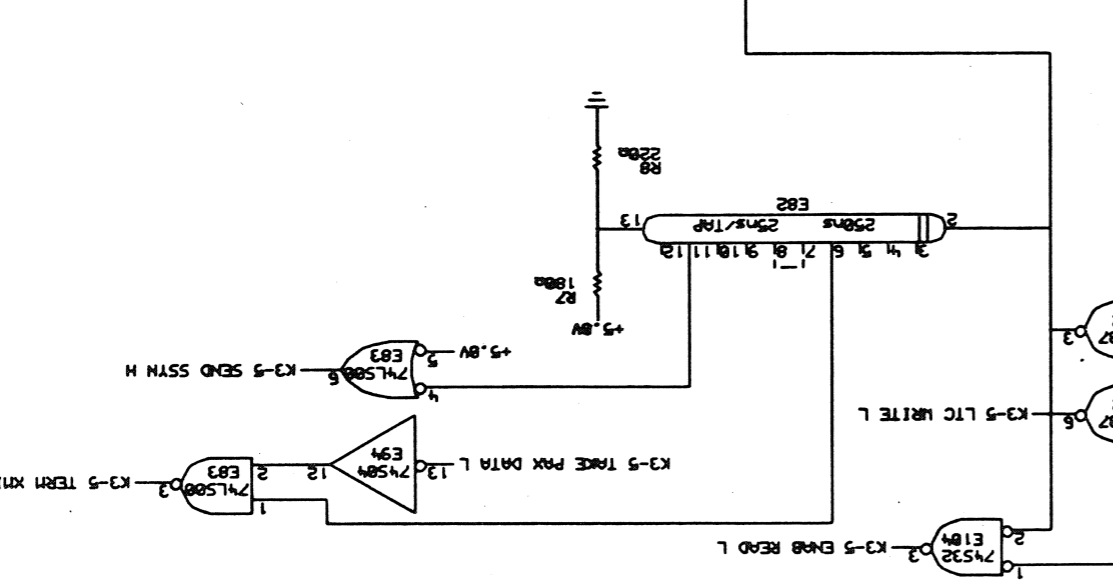
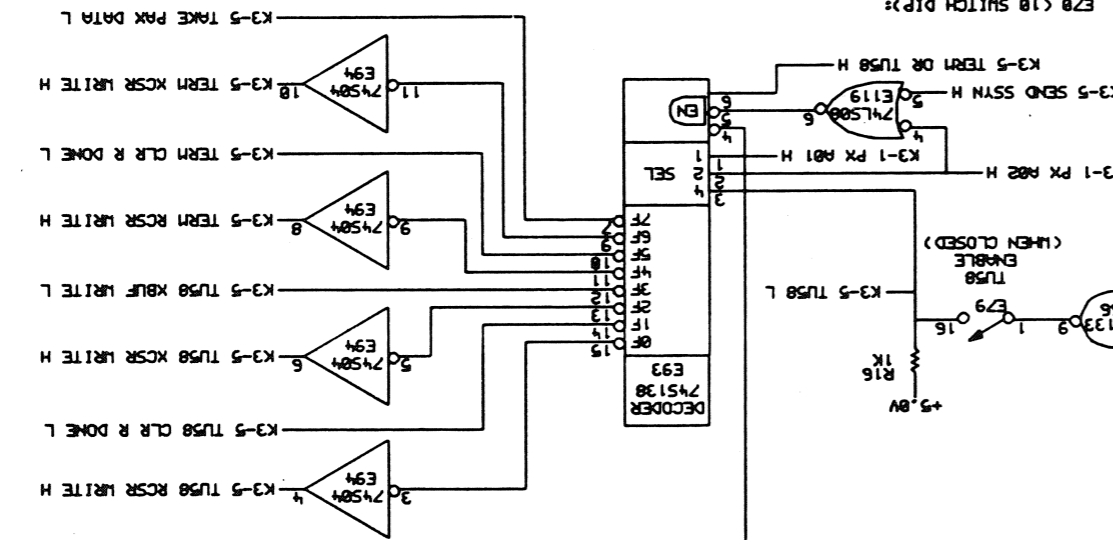

REV.	NUMBER	CS	SIZE	REV.

REV.	NUMBER	CS	SIZE	REV.

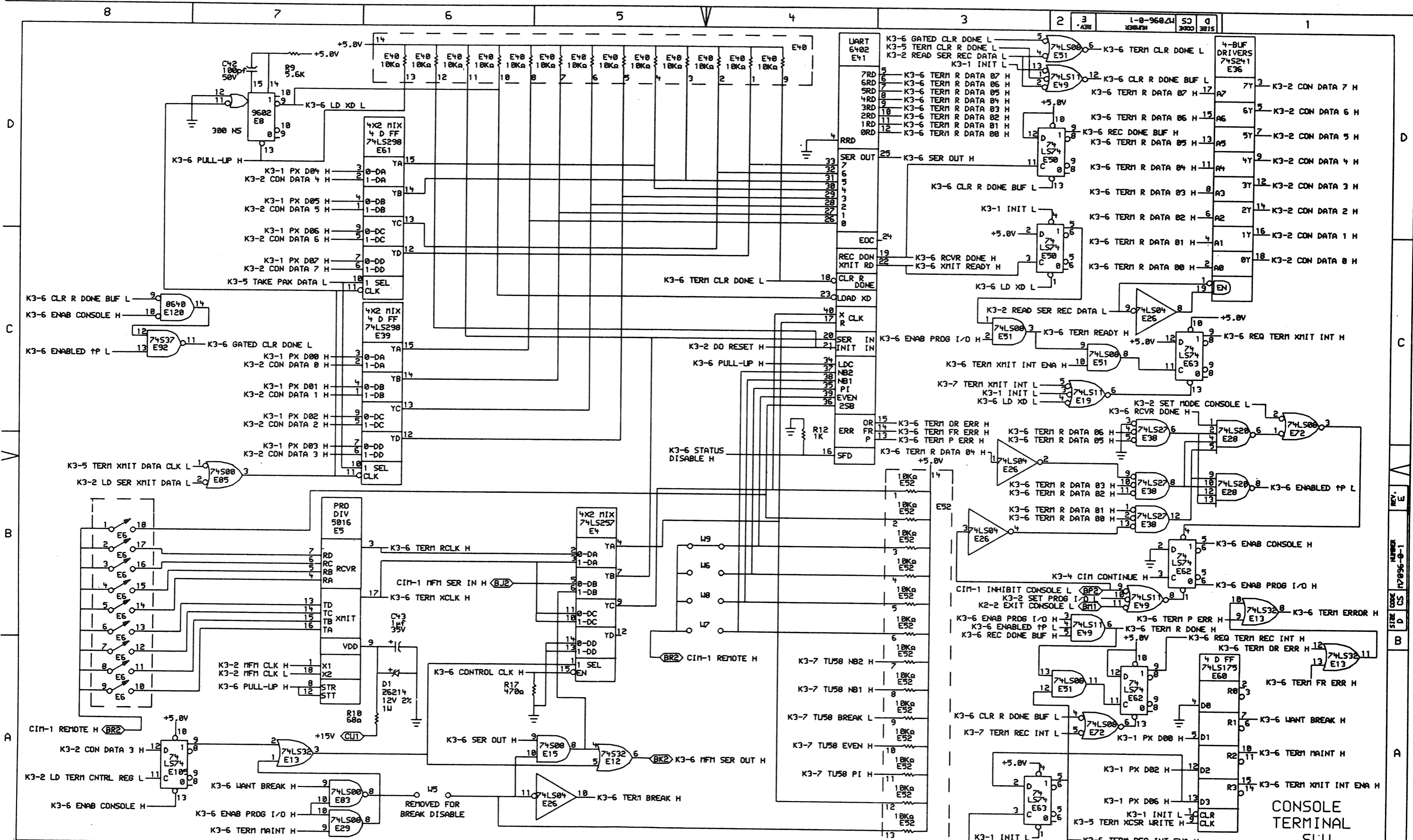

THIS DRAWING AND SPECIFICATIONS ARE THE PROPERTY OF DIGITAL EQUIPMENT CORPORATION AND SHALL NOT BE REPRODUCED OR COPIED OR USED IN WHOLE OR IN PART AS THE BASIS FOR THE MANUFACTURE OR SALE OF ITEMS WITHOUT WRITTEN PERMISSION. COPYRIGHT © 1979, DIGITAL EQUIPMENT CORPORATION.

REVISIONS	CHK	CHANGE NO.	REV

<b>digital</b>	DATE: 30-OCT-79	ENG: J. J. J.	DATE: 17-OCT-79	TITLE: (K3-6) MULTI-FUNCTION MODULE
17-OCT-79 10:33	DATE: 17-OCT-79	RECORD LOCATION: B-DD-17096-0	SHEET: 10	SIZE CODE: D
FIRST USED ON OPTION/MODEL: 11/44	DATE: 11/44	RECORD LOCATION: B-DD-17096-0	SIZE CODE: CS	NUMBER: M7096-0-1
			REV.:	

CONSOLE  
TERMINAL  
SLU





REV.	NO.	DESCRIPTION
1	1	INITIAL RELEASED FOR PRODUCTION
2	1	REVISIONS
3	1	REVISIONS
4	1	REVISIONS
5	1	REVISIONS
6	1	REVISIONS
7	1	REVISIONS
8	1	REVISIONS

REV.	NO.	DESCRIPTION
1	1	INITIAL RELEASED FOR PRODUCTION
2	1	REVISIONS
3	1	REVISIONS
4	1	REVISIONS
5	1	REVISIONS
6	1	REVISIONS
7	1	REVISIONS
8	1	REVISIONS

PAX DATA MUX / DRIVERS

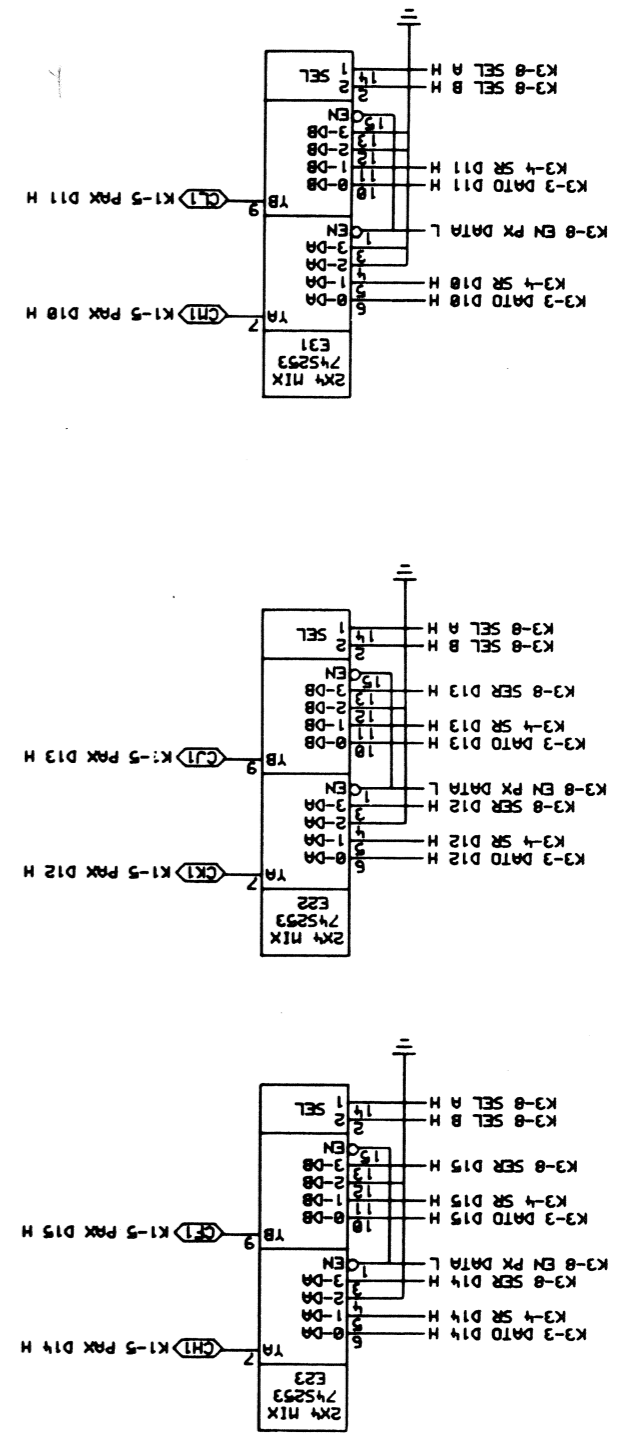
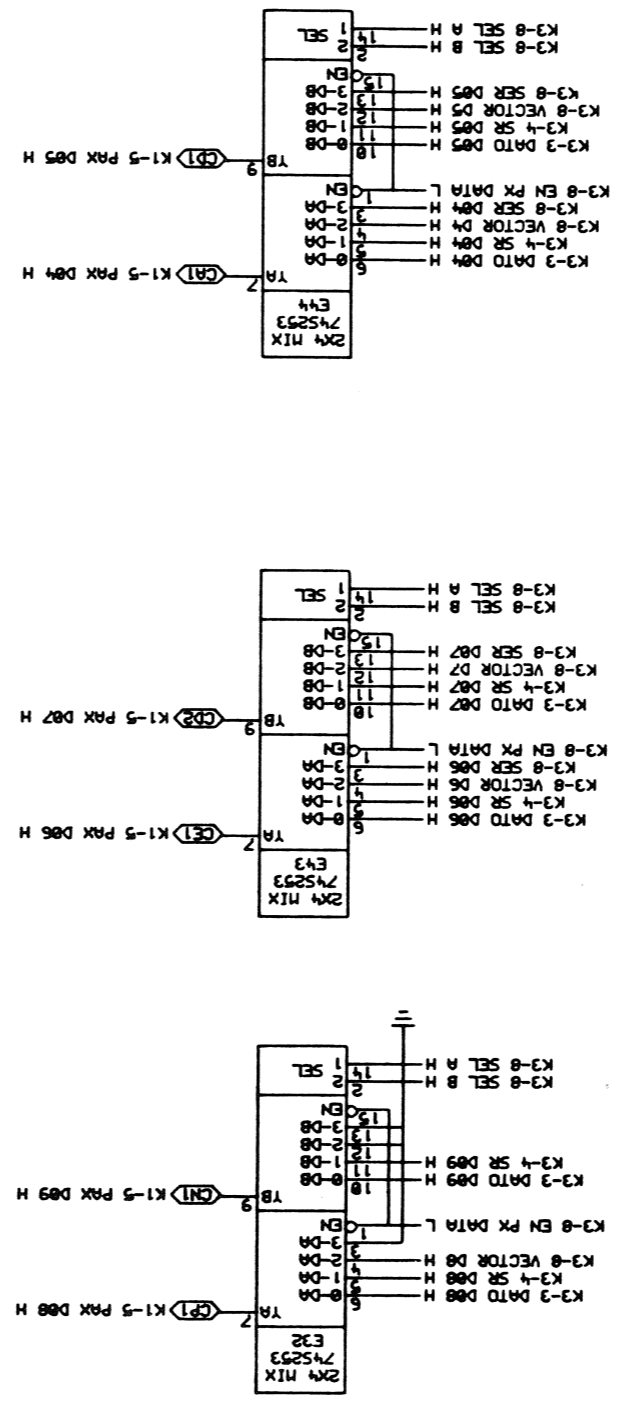
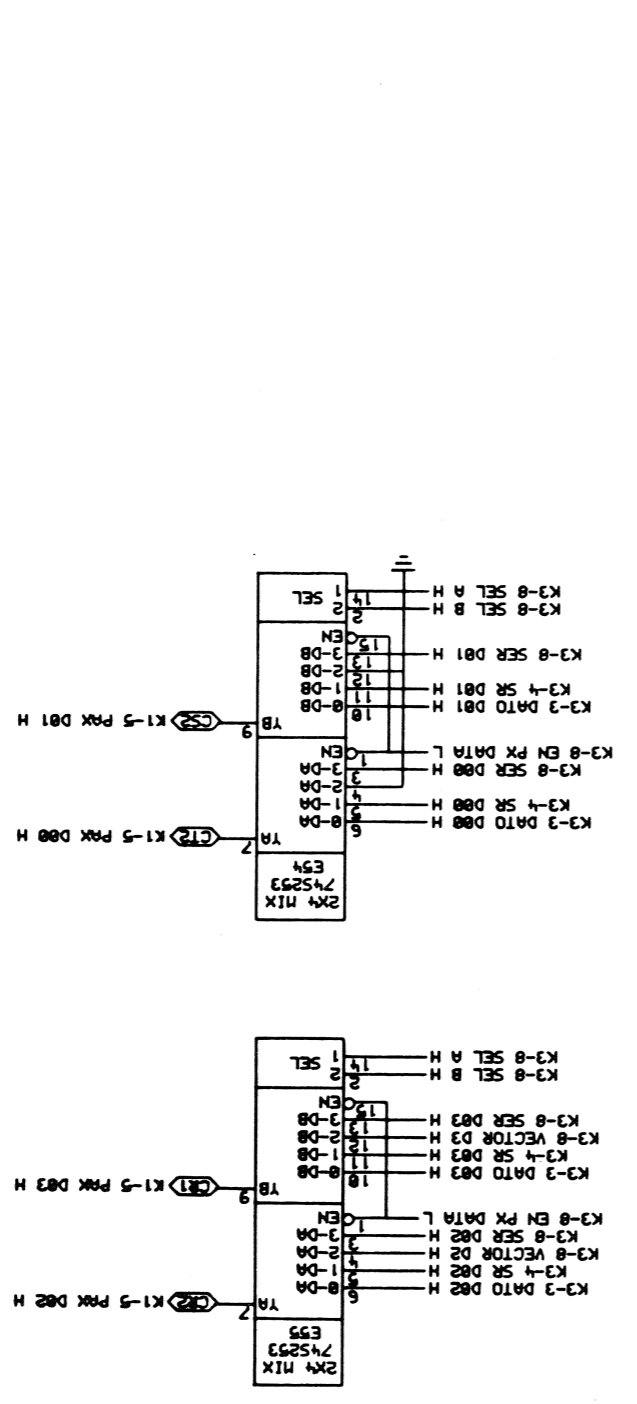
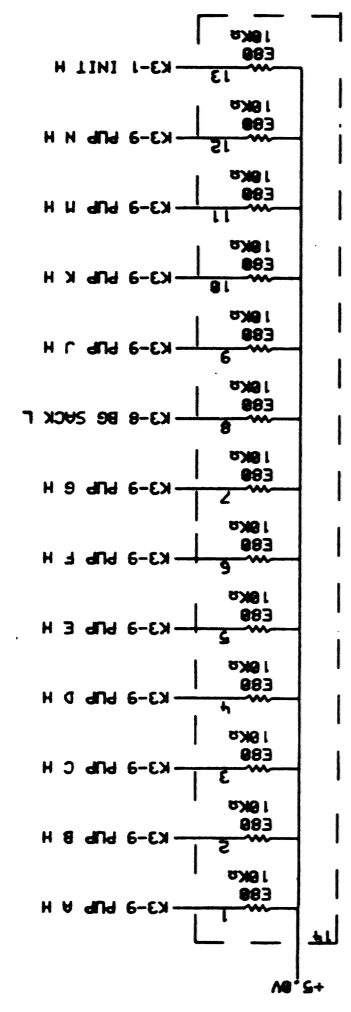

REV. E  
 NUMBER W7096-0-1  
 SIZE D  
 CODE CS

REV.	NO.	DESCRIPTION
1	1	INITIAL RELEASED FOR PRODUCTION
2	1	REVISIONS
3	1	REVISIONS
4	1	REVISIONS
5	1	REVISIONS
6	1	REVISIONS
7	1	REVISIONS
8	1	REVISIONS

REV.	NO.	DESCRIPTION
1	1	INITIAL RELEASED FOR PRODUCTION
2	1	REVISIONS
3	1	REVISIONS
4	1	REVISIONS
5	1	REVISIONS
6	1	REVISIONS
7	1	REVISIONS
8	1	REVISIONS

JUMPER DESCRIPTIONS (W1-W14, IN ORDER):

- W1 IN: CONSOLE TERMINAL ADDRESS DECODE IS ENABLED.  
 OUT: CONSOLE TERMINAL ADDRESS DECODE IS DISABLED.
- W2 IN: LINE CLOCK (LTC) ADDRESS DECODE IS ENABLED.  
 OUT: LINE CLOCK ADDRESS DECODE IS DISABLED.
- W3 IN: TU50 RECEIVER ERROR BITS ARE ENABLED IN THE TU50 RECEIVER BUFFER REGISTER (RBUF), BITS 12-15.  
 OUT: TU50 RECEIVER ERROR BITS ARE DISABLED. RBUF BITS 12-15 ARE ZERO.
- W4 IN: CONSOLE TERMINAL RECEIVER ERROR BITS ARE ENABLED IN THE CONSOLE TERMINAL RECEIVER BUFFER REGISTER (RBUF), BITS 12-15.  
 OUT: CONSOLE TERMINAL RECEIVER ERROR BITS ARE DISABLED. RBUF BITS 12-15 ARE ZERO.
- W5 IN: CONSOLE TERMINAL TRANSMITTER STATUS REGISTER (XCSR) BREAK BIT (BIT 0) IS ENABLED TO BE SET OR CLEARED.  
 OUT: CONSOLE TERMINAL XCSR BREAK BIT IS DISABLED AND WILL REMAIN CLEARED.
- W6 IN: CONSOLE TERMINAL RECEIVER PARITY DETECTION IS ENABLED, AND PARITY WILL BE GENERATED. IF W4 IS IN, THE PARITY ERROR BIT (BIT 12 IN RBUF) WILL BE SET ON A PARITY ERROR.  
 OUT: CONSOLE TERMINAL RECEIVER PARITY DETECTION AND GENERATION IS DISABLED. THE PARITY ERROR BIT WILL REMAIN CLEARED.
- W7 AND W8: THESE JUMPERS PROGRAM THE CHARACTER LENGTH FOR THE CONSOLE TERMINAL UART (E4) AS FOLLOWS:  

	5 BITS	6 BITS	7 BITS	8 BITS
W7	IN	IN	OUT	OUT
W8	IN	OUT	IN	OUT
- W9 IN: CONSOLE TERMINAL PARITY ODD/EVEN SELECT. IF W6 IS IN, ODD PARITY WILL BE GENERATED AND CHECKED.  
 OUT: CONSOLE TERMINAL PARITY ODD/EVEN SELECT. IF W6 IS IN, EVEN PARITY WILL BE GENERATED AND CHECKED.
- W10 IN: TU50 TRANSMITTER STATUS REGISTER (XCSR) BREAK BIT (BIT 0) IS ENABLED TO BE SET OR CLEARED.  
 OUT: TU50 XCSR BREAK BIT IS DISABLED AND WILL REMAIN CLEARED.
- W11 IN: TU50 RECEIVER PARITY DETECTION IS ENABLED, AND PARITY WILL BE GENERATED. IF W3 IS IN, THE PARITY ERROR BIT (BIT 12 IN RBUF) WILL BE SET ON A PARITY ERROR.  
 OUT: TU50 RECEIVER PARITY DETECTION AND GENERATION IS DISABLED. THE PARITY ERROR BIT WILL REMAIN CLEARED.
- W12 AND W13: THESE JUMPERS PROGRAM THE CHARACTER LENGTH FOR THE TU50 UART (E11) AS FOLLOWS:  

	5 BITS	6 BITS	7 BITS	8 BITS
W12	IN	IN	OUT	OUT
W13	IN	OUT	IN	OUT
- W14 IN: TU50 PARITY ODD/EVEN SELECT. IF W11 IS IN, ODD PARITY WILL BE GENERATED AND CHECKED.  
 OUT: TU50 PARITY ODD/EVEN SELECT. IF W11 IS IN, EVEN PARITY WILL BE GENERATED AND CHECKED.

SWITCH DESCRIPTIONS (E6,7, AND 79): CLOSED = ON; OPEN = OFF

- E6 (9 SWITCH DIP):
- E6-1: STOP BIT SELECT FOR CONSOLE TERMINAL. ON FOR 1 STOP BIT. OFF FOR 2 STOP BITS (OR 1.5 STOP BITS FOR 5 BIT CHARACTER LENGTH).
  - E6-2,3,4,5: CONSOLE TERMINAL RECEIVER BAUD RATE SELECT (SEE CHART BELOW). SYSTEM REMOTE MODE: 19.2 K BAUD.
  - E6-6,7,8,9: CONSOLE TERMINAL TRANSMITTER BAUD RATE SELECT. (SEE CHART BELOW). SYSTEM REMOTE MODE: 19.2 K BAUD.
- |                    |       |             |     |     |     |
|--------------------|-------|-------------|-----|-----|-----|
| RECEIVER SW.       | E6- 2 | 3           | 4   | 5   |     |
| TRANSMITTER SW.    | E6- 6 | 7           | 8   | 9   |     |
| BAUD RATE:         | 50    | ON          | ON  | ON  | ON  |
|                    | 75    | ON          | ON  | ON  | OFF |
|                    | 110   | ON          | ON  | OFF | ON  |
|                    | 134.5 | ON          | ON  | OFF | OFF |
|                    | 150   | ON          | OFF | ON  | ON  |
|                    | 200   | ON          | OFF | ON  | OFF |
|                    | 300   | ON          | OFF | OFF | ON  |
|                    | 600   | ON          | OFF | OFF | OFF |
|                    | 1200  | OFF         | ON  | ON  | ON  |
|                    | 1800  | OFF         | ON  | ON  | OFF |
|                    | 2000  | OFF         | ON  | OFF | ON  |
|                    | 2400  | OFF         | ON  | OFF | OFF |
|                    | 3600  | OFF         | OFF | ON  | ON  |
|                    | 4800  | OFF         | OFF | ON  | OFF |
|                    | 9600  | OFF         | OFF | OFF | ON  |
|                    | 19200 | OFF         | OFF | OFF | OFF |
| SYSTEM REMOTE MODE | 19200 | ANY SETTING |     |     |     |

- E79 (8 SWITCH DIP):
- E79-1: WHEN ON, TU50 ADDRESS DECODE IS ENABLED. WHEN OFF, TU50 ADDRESS DECODE IS DISABLED.
  - E79-2: WHEN ON, THE REMOTE DIAGNOSIS STATUS BITS ARE ENABLED IN BITS 3 THROUGH 5 OF THE CONSOLE TERMINAL TRANSMITTER STATUS REGISTER (XCSR). BIT 3 = "1" (E79-2 IS ON); BIT 4 = "1" WHEN IN CONSOLE MODE; BIT 5 = "1" WHEN SYSTEM IS IN REMOTE MODE. WHEN OFF, THE REMOTE DIAGNOSIS STATUS BITS ARE DISABLED, AND BITS 3 THROUGH 5 OF THE CONSOLE TERMINAL XCSR ARE ZERO.
- NOTE: E79-3 THROUGH E79-8 (TU50 VECTOR SELECT) ARE DESCRIBED ON PAGE K3-8.  
 E79-1 THROUGH E79-10 (TU50 ADDRESS SELECT) ARE DESCRIBED ON PAGE K3-5.

- E7 (7 SWITCH DIP):
- E7-1,2,3: TU50 TRANSMITTER BAUD RATE SOURCE SELECT. (SEE CHART BELOW.)
  - E7-4,5,6: TU50 RECEIVER BAUD RATE SOURCE SELECT. (SEE CHART BELOW.)
  - E7-7: STOP BIT SELECT FOR TU50. ON FOR 1 STOP BIT. OFF FOR 2 STOP BITS (OR 1.5 STOP BITS FOR 5 BIT CHARACTER LENGTH).
- |                                       |       |     |     |
|---------------------------------------|-------|-----|-----|
| TRANSMITTER SWITCH                    | E7- 1 | 2   | 3   |
| RECEIVER SWITCH                       | E7- 4 | 5   | 6   |
| BAUD RATE 38,400                      | ON    | OFF | OFF |
| BAUD RATE 9,600                       | OFF   | ON  | OFF |
| CONSOLE TERMINAL RECEIVER BAUD RATE * | OFF   | OFF | ON  |
- NOTE: NO COMBINATION OF SWITCHES E7-1 THROUGH E7-6 SHOULD BE MADE OTHER THAN AS SHOWN IN ABOVE CHART. THE BAUD RATE SOURCE FOR THE TRANSMITTER DOES NOT HAVE TO BE THE SAME AS THE BAUD RATE SOURCE FOR THE RECEIVER.
- \* : WHEN SYSTEM IS IN REMOTE MODE, THE BAUD RATE OF THE CONSOLE TERMINAL SLU IS UNCONDITIONALLY SWITCHED TO 19.2 K BAUD.

THIS DRAWING AND SPECIFICATIONS, HEREIN, ARE THE PROPERTY OF DIGITAL EQUIPMENT CORPORATION AND SHALL NOT BE REPRODUCED OR COPIED OR USED IN WHOLE OR IN PART AS THE BASIS FOR THE MANUFACTURE OR SALE OF ITEMS WITHOUT WRITTEN PERMISSION. COPYRIGHT © 1980, DIGITAL EQUIPMENT CORPORATION.

REVISIONS	
CHK	CHANGE NO. REV

digital	DATE	ENG.	DATE	TITLE:
	19-DEC-79 14:25	J. Jambly	15-FEB-80	(K3-10) MULTI-FUNCTION MODULE
(160,257)MFM100.DRW	FIRST USED ON OPTION/MODEL:	11/44	NEXT HIGHER ASSEMBLY:	B-DD-M7096-0
SIZE	CODE	NUMBER	REV.	
D	CS	M7096-0-1	E	

LINE ITEM DOCUMENT NUMBER PART NUMBER DESCRIPTION QTY PER VARIATION REFERENCE DESIGNATOR

1	5013556-00	ETCHED CIRCUIT BOARD	1	C43
2	1001776-00	1 MFD 35V 10%	1	C41
3	1002433-00	22 MFD 35V 20%	1	C41
4	1005306-00	6.8MFD 35V 10%	6	C1-C6
5	1005335-00	39 MFD 20V 10%	1	C39
6	1011895-00	15 MFD 35V 10%	1	C40
7	1012784-00	.047 MFD 50V +80-20%	37	C7-C36, C45-C50, C52
8	1013466-06	100.0 MMF 50V 5%	2	C42, C44
9	1013466-11	.22 MFD 50V +80-20% Z5U CER	1	C37
10	1109502-01	VZ= 12.0 2% 1 W 1N4742	1	D1
11	1110864-00	LED 2MCD@10MA	1	D2
12	1210711-02	/REPLACED BY 12-16988-02	1	E7
13	1211164-03	SW,DIP 7POS/1PST 5VDC100MA F	1	E79
14	1211164-04	SW,DIP 08POS/1PST 5VDC100MA F	1	E79
15	1211164-05	SW,DIP 09POS/1PST 5VDC100MA FL	1	E6
16	1211164-06	SW,DIP 10POS/1PST 5VDC100MA F	1	E70
17	1215006-03	SKT,IC 18PIN DIP TIN SLD	4	XE134, XE135, XE136, XE137
18	1215006-08	SKT,IC 40PIN DIP TIN SLD	3	XE11, XE41, XE139
19	1300019-03	R NETWORK 13-10K 5.0 % 14PIN	5	E10, E40, E52, E71, E80
20	1300219-00	68.0 25 W 5.0 % CF	2	R10, R19
21	1300271-00	220.0 25 W 5.0 % CF	2	R8, R18
22	1300316-00	470.0 25 W 5.0 % CF	1	R17
23	1300365-00	1.0 K 25 W 5.0 % CF	5	R2, R12, R13, R14, R16
24	1300479-00	10.0 K 25 W 5.0 % CF	1	R5
25	1301322-00	180.0 25 W 5.0 % CF	1	R7
26	1301874-00	5.60 K 25 W 5.0 % CF	3	R9, R11, R15
27	1302391-00	20.0 K 25 W 5.0 % CF	1	R3
28	1302394-00	30.0 K 25 W 5.0 % CF	2	R1, R6
29	1312628-01	R NETWORK 14-176.5 11-375 16PIN	1	E109
30	1611243-00	DELAY=25-250NS, 10TAPS RCL#L-183	1	E82

ENG:	ECO NUMBER	REV	SECTION A OF A	DRN:	K. FRIEDGEN	DATE:	22-MAR-79	TITLE	D I G I T A L
INITIAL			SECTION VARIATION INDEX	CHK'D:	E. T. GERRY	DATE:	22-MAR-79		
BG TW001				DES. ENG.:	B. GIST	DATE:	22-MAR-79		
BG TW003				RESP. ENG.:	B. GIST	DATE:	22-MAR-79	DOCUMENT NUMBER	
BG TW004				MFG. ENG.:	J. COMELLA	DATE:	10-MAY-79	SIZE: CODE NUMBER	REV
F. C. M7096-ML006				ASSEMBLY NUMBER:	D-UA-M7096-0-0	TOP DOCUMENT NUMBER:		FILE NAME:	Z0622E.PLS
								EDIT #	15

"THIS DRAWING AND SPECIFICATIONS HEREIN, ARE THE PROPERTY OF DIGITAL EQUIPMENT CORPORATION AND SHALL NOT BE REPRODUCED OR COPIED OR USED IN WHOLE OR IN PART AS THE BASIS FOR THE MANUFACTURE OR SALE OF ITEMS WITHOUT WRITTEN PERMISSION. COPYRIGHT (C) 1983. DIGITAL EQUIPMENT CORPORATION"

LINE ITEM	DOCUMENT NUMBER	PART NUMBER	DESCRIPTION	QTY PER VARIATION 00	REFERENCE DESIGNATOR
31	31	1811660-23	OSCILLATOR, XTAL 5.5296 MHZ	1	E141
32	32	1909705-00	DEC 8881 NAND GATE-QUAD 2IN 0	1	E111
33	33	1910532-00	74S00 NAND GATE-QUAD 2IN	2	E85,E88
34	34	1910534-00	74S04 INVERTER GATE-HEX 1I	3	E94,E113,E116
35	35	1910537-00	74S11 AND GATE-TRIPLE 3INP	1	E74
36	36	1910544-00	74S74 FF-D DUAL,EDGE TRIGG	1	E110
37	37	1910545-00	74S112 FF-JK DUAL,EDGE TRIG	1	E118
38	38	1910549-00	74S158 MUX 1 OF 2 (QUAD)	2	E57,E77
39	39	1910550-00	74S174 FF-D HEX	1	E96
40	40	1910951-00	9602 ONE SHOT-DUAL	3	E8,E35,E37
41	41	1911324-00	7414 INVERTER,HEX 1IN SCH	1	E81
42	42	1911469-00	DEC 8640 RECEIVER,BUS,QUAD,U	3	E107,E120,E140
43	43	1911579-00	8641 TRANSCEIVER,BUS,QUA	1	E99
44	44	1911675-00	74S138 DECODER/DEMUX 3-8 LI	4	E93,E100,E103,E121
45	45	1911983-00	74S133 NAND GATE-POSITIVE 1	2	E66,E87
46	46	1912096-00	DEC 74S86 XOR GATE,QUAD 2IN	3	E65,E68,E69
47	47	1912389-00	74S08 AND GATE-QUAD 2IN,PO	1	E15
48	48	1912647-00	LS257 MUX 1 OF 2 (QUAD)	2	E4,E18
49	49	1912660-00	74S253 MUX 1 OF 4 (DUAL)	8	E22,E23,E31,E32,E43,E44,E54,E55
50	50	1912697-00	LS174 FF-D HEX W/CLEAR	1	E90
51	51	1912746-00	DEC 74S37 NAND GATE-QUAD 2IN	1	E92
52	52	1912799-00	LS00 NAND-GATE-QUAD 2IN,P	3	E83,E112,E138
53	53	1912803-00	LS04 INVERTER GATE,HEX	1	E26
54	54	1912805-00	LS08 AND GATE-QUAD 2IN,PO	7	E29,E30,E46,E51,E72,E115,E119
55	55	1912808-00	LS11 AND GATE-TRIPLE 3IN	2	E49,E19
56	56	1912810-00	LS20 NAND GATE-DUAL 4IN	1	E28
57	57	1912813-00	LS27 NOR GATE-TRIPLE 3IN	1	E38
58	58	1912816-00	LS32 OR GATE-QUAD 2IN,POS	4	E3,E13,E84,E106
59	59	1912824-00	LS74 FF-D DUAL,EDGE TRIGG	8	E20,E27,E50,E59,E62,E63,E105, CONT E114
60	60	1912834-00	LS112 FF-JK,DUAL,EDGE TRIG	1	E108
61	61	1912842-00	LS138 DECODER-THREE INPUT,	1	E102
62	62	1912844-00	LS151 MUX 1 OF 8 & DATA	2	E47,E48
63	63	1912845-00	LS153 MUX 1 OF 4 (DUAL)	3	E16,E17,E58
64	64	1912847-00	LS157 MUX 1 OF 2(QUAD)	1	E14
65	65	1912851-00	LS169 COUNTER,SYNCH. UP/DO	1	E129
66	66	1912853-00	LS175 FF-D QUAD	4	E21,E60,E101,E122
67	67	1912863-00	LS273 FF-D OCTAL W/CLEAR	5	E9,E24,E25,E33,E34
68	68	1912867-00	LS298 MUX 1 OF 4,2IN W/S	2	E39,E61
69	69	1913340-00	74S32 OR GATE-QUAD 2IN	5	E12,E73,E104,E130,E131
70	70	1913493-00	74S241 OCTAL BUFFER,TRI-STA	10	E36,E45,E53,E64,E75,E86,E124, CONT E125,E127,E128
71	71	1913670-00	74S373 LATCH,8BIT TRANS TRI	1	E123
72	72	1913671-00	74S374 FF-D,OCTAL,TR1 STATE	5	E42,E56,E67,E78,E89
73	73	1914086-00	74S30 NAND GATE-POS 8IN	2	E76,E117
74	74	1914438-00	DC 013 UNIBUS INTERRUPT-BIP	2	E97,E98
75	75	1915697-00	RAM 256X4 TRI-STATE	2	E132,E133
76	76	2112623-02	DUAL BAUD RATE GEN/PROG DIVIDER	1	E5

D	I	G	I	T	A	L	TITLE	SECTION A	OF A	SIZE	CODE	DOCUMENT NUMBER	REV
							KD11-Z MULTI-FUNCTION			K	PL	M7096-0-DBP	E

P A R T S L I S T

QTY PER VARIATION REFERENCE DESIGNATOR

LINE ITEM	DOCUMENT NUMBER	PART NUMBER	DESCRIPTION	QTY	REFERENCE DESIGNATOR
77		2113937-00	UART 125K BUAD	2	E11,E41
78		2114963-00	UP,8-BIT NMOS	1	E139
79		23017F2-00	*** THIS ITEM IS NOT USED ***	-	
80		23018F2-00	*** THIS ITEM IS NOT USED ***	-	
81		23019F2-00	*** THIS ITEM IS NOT USED ***	-	
82		23261A1-00	A1-07	1	E95
83		23847A9-00	A9-01	1	E126
84		23848A9-00	A9-01	1	E91
85		9000024-01	EYELET,ROLLED	12	
86		9009157-00	ADH,LIG,RM,TEMP CURING COLORLESS	A/R	
87		9009185-00	JUMPER, WIRE, INSULATED, BLACK B	S	W1-W3,W9,W10
88		9105740-55	WIRE(WRAP) 30AWG KYNAR UL14	1	
89		1914451-00	LS393 COUNTER,BINARY,4BIT	1	E2
90		23020F2-00	*** THIS ITEM IS NOT USED ***	-	
91		1004813-00	10 MFD 20V 10% S.TANT	1	CS1
92		1105275-00	PIV= 60 IO=300 MA -15NS	1	D3
93		1302466-00	100.0 K .25 W 5.0 % CF	1	R4
94		23099F2-00	F2-01	1	E134
95		23100F2-00	F2-01	1	E135
96		23101F2-00	F2-01	1	E136
97		23102F2-00	F2-01	1	E137

YEAR	RR	RR	83
D	I	G	I
T	A	L	
TITLE			
KD11-Z MULTI-FUNCTION			
SECTION A OF A			
SIZE	CODE	DOCUMENT NUMBER	REV
K	PL	M7096-0-DBP	E