

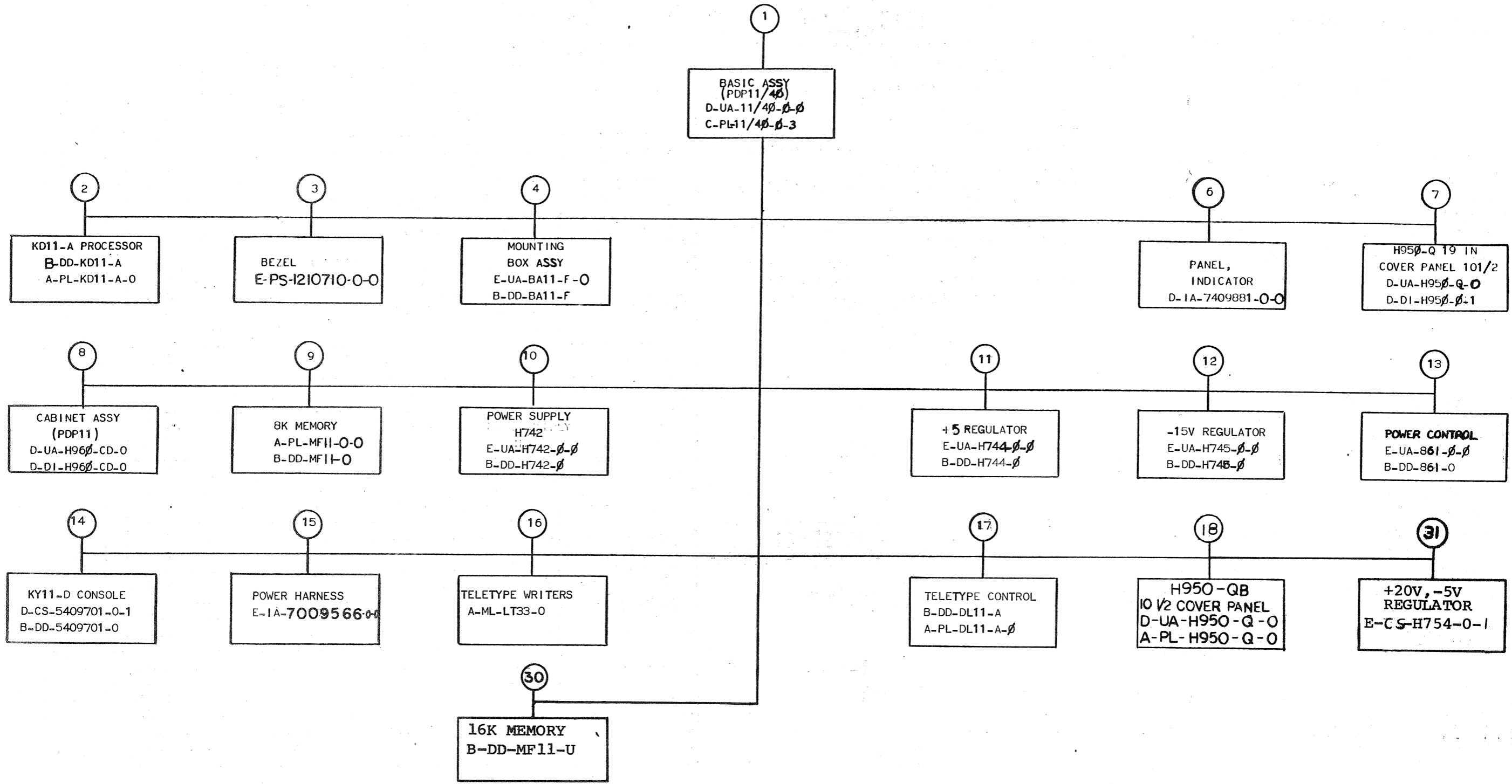

**PDP-11/40 system  
engineering drawings**





CENTER LINE

TITLE	SIZE	CODE	NUMBER	REV
BASIC ASSY (PDP 11/40)	B	DD	11/40-0	P

SHEET 2 OF 6

Center Line

Used for 11/40-<sup>CS</sup>/<sub>CT</sub> Only

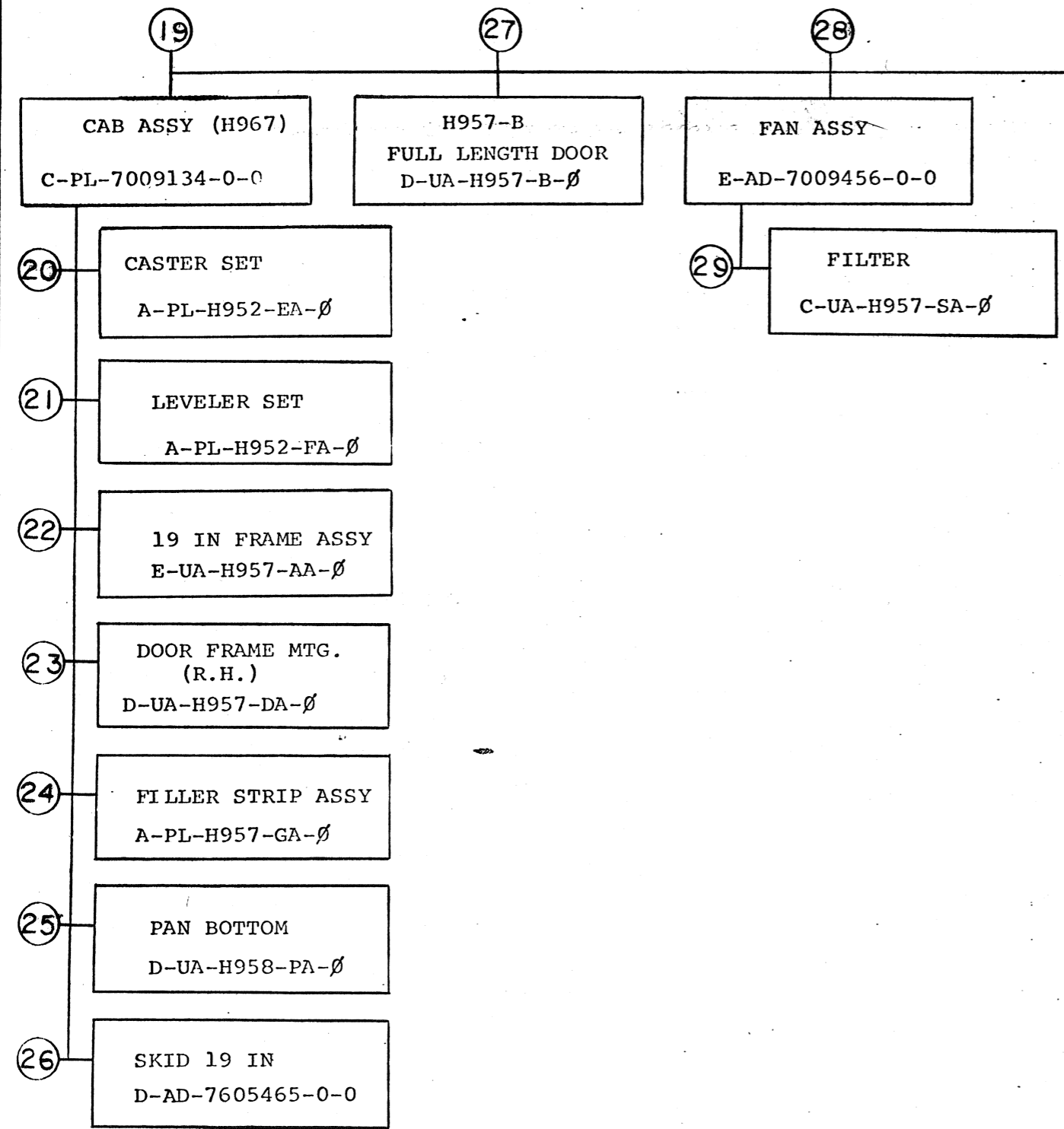

TITLE	BASIC ASSY (PDP 11/40)	SIZE CODE	NUMBER	REV
	SHEET 3 of 6	B DD	11/40-Ø	B

CUSTOMER PRINT SET				ELECTRICAL					CUSTOMER PRINT SET				ELECTRICAL								
11/40-1				MFG. SET	FIND NO.	REV	NO OF SHT	DESCRIPTION	OPTION NO.	11/40-1				MFG. SET	FIND NO.	REV	NO OF SHT	DESCRIPTION	OPTION NO.		
X					1		6	BASIC ASSY (11/40)		C					12	B-DD-H745-0	#	3	-15V REGULATOR DRAWING DIRECTORY		
X							4	BASIC ASSY (11/40) P.L.													
X							1	A.C. DISTRIBUTION (11/40)													
X							2	ASSY CONFIGURATION (11/40)													
X							1	ACCESSORY LIST (11/40)		C					13	B-DD-861-0	#	2	POWER CONTROL DRAWING DIRECTORY		
X							1	SOFTWARE LIST (11/40)													
X							1	861 CONSOLE TO PWR CONTROL HARNESS													
				X			23	PDP11/35E11/40 BASIC BUILD AND ACCEPTANCE PROCEDURE		C					14	B-DD-KY11-D	#	2	DRAWING DIRECTORY		
				X			49	PDP11/35E11/40 SYSTEM BUILD AND ACCEPTANCE PROCEDURE					X		D-CS-5409701-0-1	#	3	KY11-D CONSOLE			
X							1	EXPANDER BOX POWER HARNESS													
X							1	POWER HARNESS													
X							1	KD11-A POWER HARNESS													
X							1	6-PIN JUMPER HARNESS		X					15	E-IA-7009566-0-0	#	1	EXPANDER POWER HARNESS		
C							#	KD11-A PROCESSOR DRAWING DIRECTORY		C											
							#														
				X	4		#	MOUNTING BOX ASSY DRAWING DIRECTORY		C					16	A-ML-LT33-0	#	2	TELETYPE WRITERS		
X							#	MOUNTING BOX ASSY													
X							#	POWER DISTRIBUTION CABLE													
										C					17	B-DD-DL11-A	#	3	ASYNCHRONOUS LINE INTERFACE		
										C					30	B-DD-MF11-U			16K MEMORY DRAWING DIRECTORY		
C					9		#	8K MEMORY DRAWING DIRECTORY		X					31	E-CS-H754-0-1	#		+20V, -5V REGULATOR		
X								MF11-L/LP FIRST MEMORY POWER HARNESS													
C					10		#	H742 POWER SUPPLY DRAWING DIRECTORY													
C					11		#	+5 REGULATOR DRAWING DIRECTORY													
TITLE										BASIC ASSY (11/40)					SHEET 4 OF 6		SIZE CODE		NUMBER		REV
															B DD		11/40-0		P		

DRB 108

DEC - 16 - (325)-1062-2A-R272



CUSTOMER PRINT SET		MACHANICAL					CUSTOMER PRINT SET		MACHANICAL						
	MFG. SET	FIND NO.	DRAWING NO.	REV	NO OF SHT	DESCRIPTION	OPTION NO./FILE DATE		MFG. SET	FIND NO.	DRAWING NO.	REV	NO OF SHT	DESCRIPTION	OPTION NO./FILE DATE
		19	C-PL-7009134-0-0		1	CAB ASSY (H967)									
			A-PS-1211442-0-0		1	COUNTER-WEIGHT									
			B-DD-MF11-U			16K MEMORY DRAWING DIRECTORY									
		20	A-PL-H952-EA-Ø		1	CASTER SET									
			B-DD-H754-0			+20V; -5V REGULATOR DRAWING DIRECTORY									
		21	A-PL-H952-FA-Ø		1	LEVELER SET									
		22	E-UA-H957-AA-Ø		4	19 IN FRAME ASSY									
		23	D-UA-H957-DA-Ø		1	DOOR FRAME MTG (R.H.)									
		24	A-PL-H957-CA-Ø		1	FILLER STRIP ASSY									
		25	D-UA-H958-PA-Ø		1	PAN BOTTOM									
		26	D-AD-7605465-0-0		1	SKID 19 IN									
		27	D-UA-H957-B-Ø		1	FULL LENGTH DOOR									
		28	D-AD-7009456-0-0		1	FAN ASSY									
			D-IA-7409126-0-0		1	PANEL FAN									
			A-PS-1210165-0-0		1	FAN (115V)									
			A-PS-1209175-0-0		1	FINGER GUARD									
			A-PS-1209798-0-0		1	FAN CARAVEL (230V)									
		29	C-UA-H957-SA-Ø		1	FILTER									
		#30	B-DD-MF11-U			16K MEMORY DRAWING DIRECTORY									
		#31	E-CS-H754-0-1			+20V, -5V REGULATOR									

CUSTOMER PRINT SET CODES  
X = PRINT OF DOCUMENT INCLUDED IN PRINT SET  
C = INCLUDES ALL PRINTS INDICATED ON DOCUMENT  
S = CONFIDENTIAL AUTHORIZED SIGNATURE REQUIRED

TITLE  
BASIC ASSY (11/4Ø)  
SHEET 6 OF 6  
SIZE CODE B DD  
NUMBER 11/4Ø-Ø  
REV P



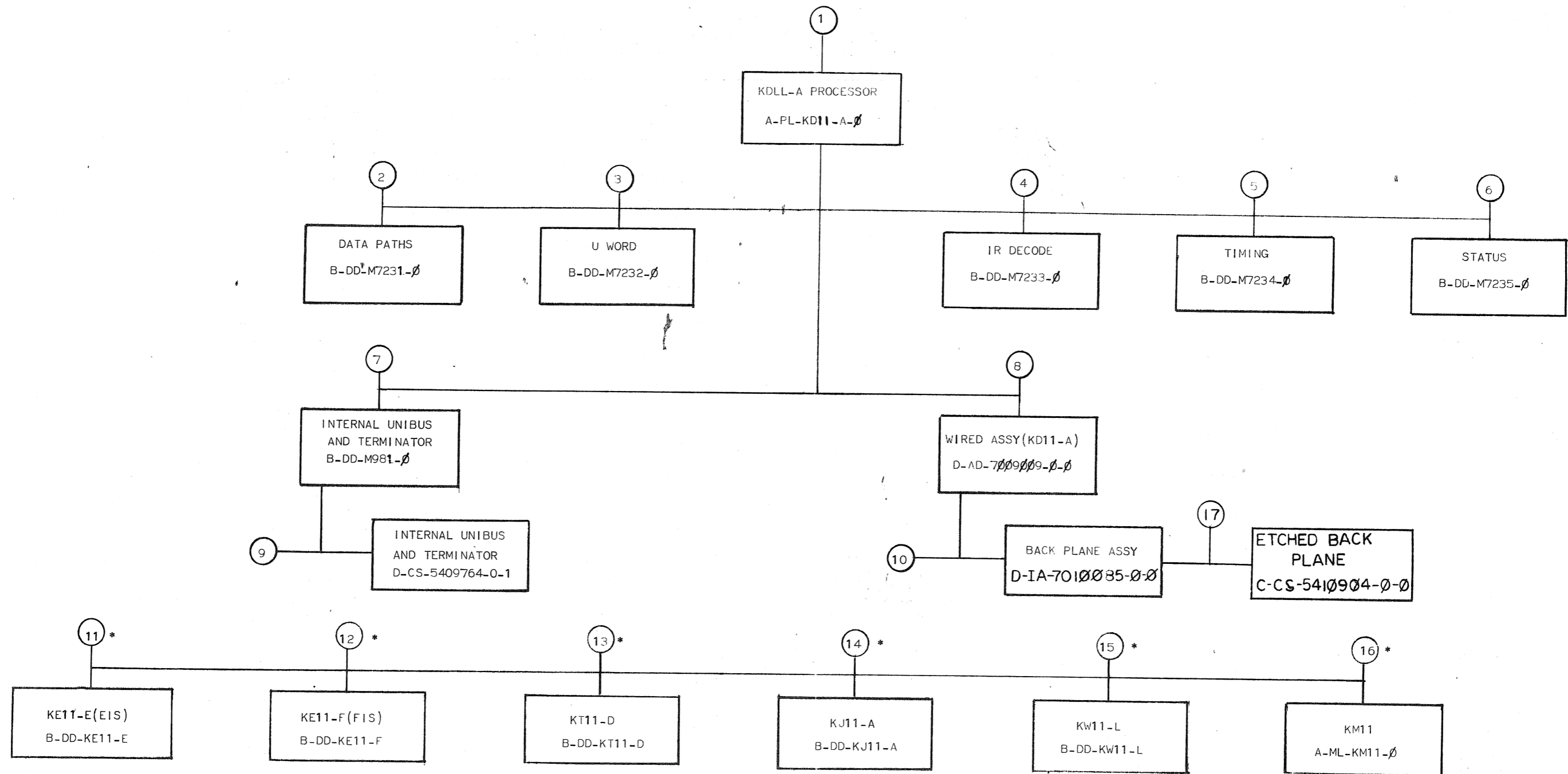

\* OPTIONS TO KD11-A PROCESSOR

TITLE	SHEET 2 OF 3	SIZE CODE	NUMBER	REV
KD11-A PROCESSOR		B DD	KD11-A	F



This drawing and specifications herein are the property of Digital Equipment Corporation and shall not be reproduced or copied in whole or in part as the basis for the manufacture or sale of items without written permission.

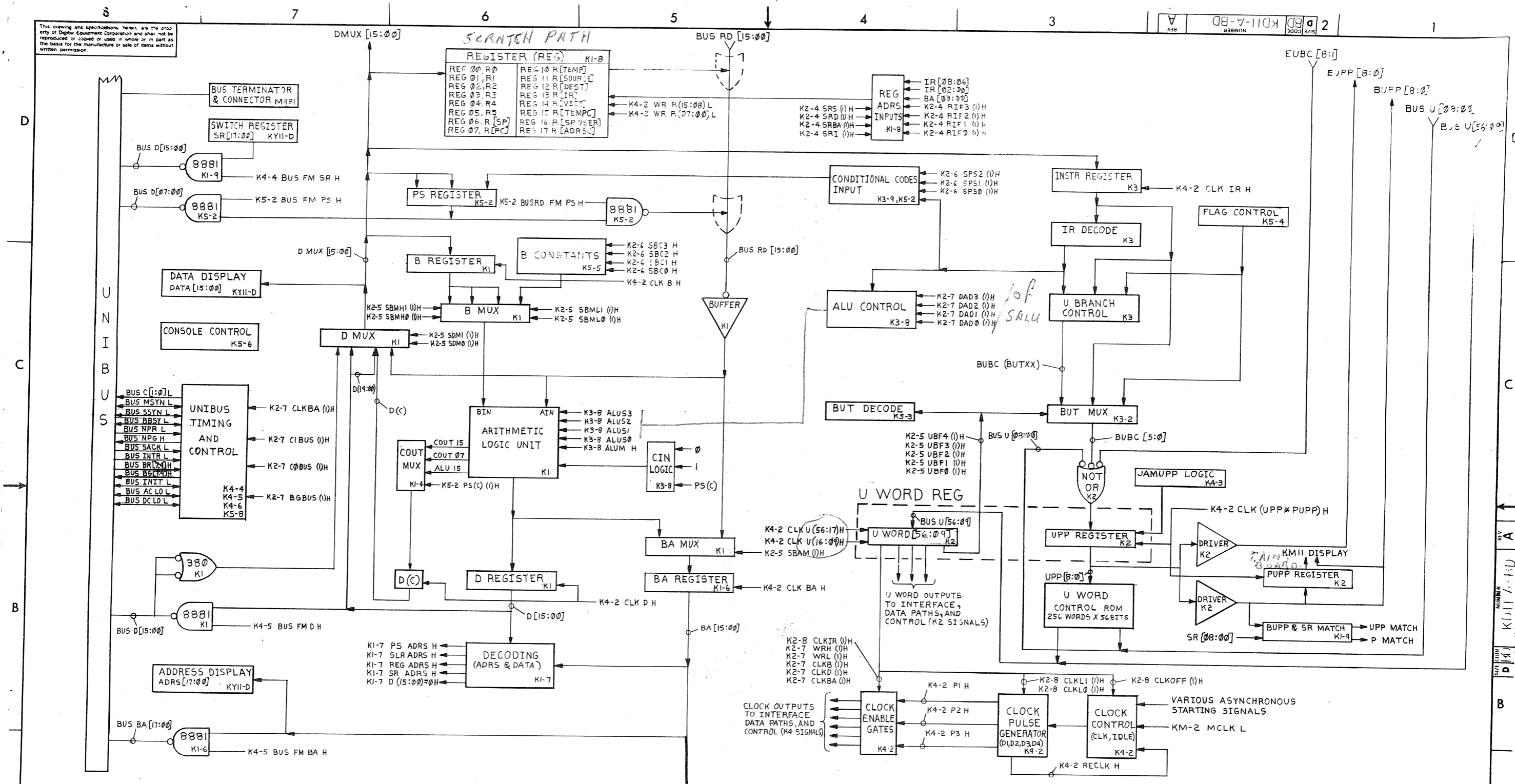

INTERFACE DATA PATHS MICROCONTROL TO KTIID

BRUNING 40-522 15840

REV	CHANGE NO.	DATE
A	0005	7-21-72
B	0006	8-25-72
C	0007	9-25-72
D	0008	9-25-72

DESIGNED BY: O. LOUGHLIN  
 CHECKED BY: J. CHANG  
 DATE: 2-14-73

FIRST USED ON OPTION/MODEL	QTY.	DESCRIPTION	PART NO.	ITEM NO.
POPPII				
UNLESS OTHERWISE SPECIFIED DIMENSION IN INCHES. TOLERANCES				
DECIMALS		ANGLES		
XXX = .005		±0° 30'		
XX = .02				
X = .1				
REMOVE BURRS AND BREAK SHARP CORNERS SURFACE QUALITY				
MATERIAL				
NEXT HIGHER ASSY.				
FINISH				

DRN	DATE	CHK'D	DATE	ENGR	DATE	PROJ. ENGR	DATE	REVISION	DATE
J. Sullivan	7-21-72	J. Sullivan	8-25-72	J. Sullivan	9-25-72	J. Sullivan	9-25-72		
J. Sullivan		J. Sullivan		J. Sullivan		J. Sullivan			
J. Sullivan		J. Sullivan		J. Sullivan		J. Sullivan			

TITLE: KDI1A PROCESSOR (BLOCK DIAGRAM)

SCALE: 1" = 1" OF ACTUAL

SHEET 7 OF 8

DIST. DBD KDI1A-BD

