

VAX 6000 CI/Embedded Storage Installation Manual

Order Number EK-62X34-IN-003

This manual describes for Digital Customer Service engineers the installation of the 62X34-SA/-SB and 62X34-RA/-RB CI/Embedded Storage Kits and the routing/configuration of cables necessary to connect and/or dual port VAX 6000 CI/Embedded Storage Options to HSCs.

**Digital Equipment Corporation
Maynard, Massachusetts**

The information in this document is subject to change without notice and should not be construed as a commitment by Digital Equipment Corporation. Digital Equipment Corporation assumes no responsibility for any errors that may appear in this document.

Restricted Rights: Use, duplication, or disclosure by the U.S. Government is subject to restrictions as set forth in subparagraph (c)(1)(ii) of the Rights in Technical Data and Computer Software clause at DFARS 252.227-7013.

FCC Notice: The equipment described in this manual generates, uses, and may emit radio frequency energy. The equipment has been type tested and found to comply with the limits for a Class A computing device pursuant to Subpart J of Part 15 of FCC Rules, which are designed to provide reasonable protection against such radio frequency interference when operated in a commercial environment. Operation of this equipment in a residential area may cause interference, in which case the user at his own expense may be required to take measures to correct the interference.

© Digital Equipment Corporation 1991.

All Rights Reserved.
Printed in U.S.A.

The postpaid Reader's Comments forms at the end of this document request your critical evaluation to assist in preparing future documentation.

The following are trademarks of Digital Equipment Corporation:

DEC	PDP11	VAXft
DECUS	TMSCP	VAXserver
DSSI	VAX	VMS
KFMSA	VAX 4000	XMI
KFQSA	VAX 6000	
MicroVAX	VAX 9000	
MSCP	VAXcluster	

This document was prepared using VAX DOCUMENT, Version 2.1.

Contents

About this manual	v
-------------------	---

Chapter 1 Safety Precautions

1.1 Introduction	1-1
1.2 Hazards and Safety Precautions	1-1
1.3 ESD Precautions	1-1

Chapter 2 VAX 6000 CI/Embedded Storage Kits

2.1 Introduction	2-1
2.2 62X34-SA/-SB Kit Contents	2-2
2.3 62X34-RA/-RB Kit Contents	2-2
2.4 BC26V Cables	2-3

Chapter 3 Installing the 62X34-SA/-SB and 62X34-RA/-RB Kit Hardware

3.1 Introduction	3-1
3.2 Powering Down the VAX 6000 Series Cabinet	3-1
3.3 Installing 62X34-SA/-SB and 62X34-RA/-RB Kit Hardware	3-2
3.4 Preparing the VAX 6000 System Cabinet for 62X34 Kit Installation	3-2
3.5 Installing Mounting Brackets and Cable Tray	3-2
3.5.1 Installing the Left Mounting Bracket	3-2
3.5.2 Installing the Right Mounting Bracket	3-3
3.5.3 Installing the Cable Tray	3-3
3.6 Installing Cable Routing Hardware	3-5
3.6.1 Installing 62X34-SA/SB Kit Cable Routing Hardware	3-5
3.6.2 Installing 62X34-RA/RB Kit Cable Routing Hardware	3-8

Chapter 4 Cable Routing

4.1	Introduction	4-1
4.2	Routing and Connecting SA7x and RA9x I/O Cables	4-1
4.3	Routing and Connecting BC26V SDI Cables	4-3
4.3.1	SA7x Configurations	4-4
4.3.1.1	Single SA7x/single port configurations to an HSC	4-4
4.3.1.2	Dual SA7x/single port configurations	4-4
4.3.1.3	Single SA7x/dual port configurations	4-4
4.3.1.4	Dual SA7x/dual port configurations	4-5
4.3.1.5	RA9x Configurations	4-5
4.3.1.6	Mixed SA7x/RA9x Configurations	4-5
4.3.2	Preparing the VAX 6000 System Cabinet for Powering Up	4-6
4.3.3	Powering Up the VAX 6000 System Cabinet	4-6
4.3.4	Verification of Drive Operation and HSC Connections	4-6

Chapter 5 VAX 6000 Embedded Storage Documentation

5.1	Introduction	5-1
5.2	6000 Embedded Storage and Related HSC Manuals	5-1

Index

Figures

3-1	Bracketry Installation for the CI Embedded Storage kit	3-4
3-2	SA7x Cable Routing Hardware Installation for CI Embedded Storage Kit.	3-7
3-3	RA9x Cable Routing Hardware Installation for CI Embedded Storage Kit.	3-9
4-1	SA7x (17-01699-01) or RA9x (17-01482-01) Cable Configurations	4-2
4-2	Single SA7x...A Ported to KDB50...B Ported to a HSC	4-7
4-3	Dual SA7xs...A Ported to KDB50...B Ported to a HSC	4-8
4-4	Single SA7x...A and B Ported to a HSC	4-9
4-5	Dual SA7xs...A and B Ported to a HSC	4-10
4-6	Single RA9x...A Ported to KDB50...B Ported to a HSC	4-11
4-7	Dual RA9xs...A Ported to KDB50...B Ported to a HSC	4-12
4-8	Single RA9x...A and B Ported to a HSC	4-13
4-9	Dual RA9xs...A and B Ported to a HSC	4-14

Tables

2-1	62X34-SA/-SB Kit Parts List	2-2
2-2	62X34-RA/-RB Kit Parts List	2-3
4-1	Cable Configurations	4-3
5-1	Related Documentation	5-1

About this manual

This manual describes:

- Safety precautions for Digital Customer Service engineers working with the VAX 6000 Series System Cabinet
- How to install 62X34-SA/-SB and 62X34-RA/-RB CI/Embedded Storage Kits into a VAX 6000 Series System Cabinet
- Cable configuration and cable management of cables connecting and dual porting VAX 6000 CI/Embedded Storage options to HSCs

Intended Audience

All Digital Customer Service Engineers installing 62X34 CI/Embedded Storage Kits into a VAX 6000 Series Cabinet should read this manual. Without the information in this manual, proper installation cannot be done.

Document structure

This document is divided into the following chapters:

chapter	describes
1	Safety and ESD precautions for Digital Customer Service Engineers
2	The contents of the 62X34-SA/-SB and 62X34-RA/-RB Kits
3	How to install the 62X34-SA/SB and 62X34-RA/-RB Kit hardware
4	Cable routing and configurations
5	VAX 6000 Embedded Storage Documentation List

Scope

The purpose of this manual is to describe the installation of the 62X34-SA/-SB and 62X34-RA/-RB CI/Embedded Storage Kits and the routing/configuration of cables necessary to connect and/or dual port VAX 6000 CI/Embedded Storage Options to HSCs.

General information about the VAX 6000 Series System and field acceptance procedures are not contained in this manual. Refer to documentation for the 6000 series cabinets for that information.

Information about installing SA7x and RA9x Embedded Storage Options or Embedded Storage Upgrade Kits is also not included in this manual. Refer to manuals EK-SA7CK-IN and EK-RA9CK-IN and document EK-62X34-CL for this information.

Chapter 1

Safety Precautions

1.1 Introduction

This chapter discusses hazards and safety precautions that the Digital Customer Service engineer should be aware of before installing a 62X34-SA/-SB or 62X34-RA/-RB CI/Embedded Storage Kit.

WARNING

Installation of and all maintenance related to 62X34-SA/-SB and 62X34-RA/-RB Kits can only be performed by qualified Digital Customer Service engineers. Digital customer access to VAX 6000 Embedded Storage Options is limited to access of RA9x and SA7x operator control panels (OCPs) through the access slot in the system cabinet front door. Digital Customer Access to VAX 6000 Embedded RA9xs, SA7xs, or associated hardware or cables through system cabinet front or rear doors is prohibited.

1.2 Hazards and Safety Precautions

The front and rear doors of a VAX 6000 series processor cabinets are considered safety barriers. High voltages, as well as the blower assembly, are accessible once the front door is opened and high voltages are accessible once the rear door is opened. Both cabinet doors are locked and cannot be opened without a 5/32 hex key. Only Digital Customer Service engineers can open the front or rear door without violating Digital safety measures.

1.3 ESD Precautions

Only Digital Customer Service engineers with training in electrostatic discharge (ESD) procedures should install any VAX 6000 Embedded Storage options or kits or work with the processor cabinet.

Digital Customer Service engineers must wear proper ESD protective ground straps connected to a good ground when accessing, installing, or repairing Embedded Storage options or VAX 6000 series processor cabinets. ESD kits, containing protective ground straps, are behind the front and rear doors of the processor cabinets. Use the ground strap when working with the processor cabinets. When working with a VAX 6000 Embedded Storage Option, use a separate ground strap connected to the option being worked on.

Chapter 2

VAX 6000 CI/Embedded Storage Kits

2.1 Introduction

This chapter describes the 62X34-SA/-SB and 62X34-RA/-RB VAX 6000 CI/Embedded Storage Kits parts lists. These kits are required for connecting or Dual Porting VAX 6000 Embedded SA7x and RA9x options to HSCs.

There are four VAX 6000 CI/Embedded Storage Kits:

Kit	Description
62X34-SA	If the customer wants to connect a first embedded storage option in the VAX 6000 cabinet to an HSC and the option is an SA7x, the 62X34-SA kit is required because it contains the required hardware brackets and cable tray.
62X34-SB	If the customer already has one embedded storage option (SA7x or RA9x) in the VAX 6000 cabinet connected to an HSC, wants to connect a second option, and the second option is an SA7x, the 62X34-SB kit is required. The 62X34-SB kit does not contain the hardware brackets and cable tray needed only for connecting the first embedded storage option to an HSC.
62X34-RA	If the customer wants to connect a first embedded storage option in the VAX 6000 cabinet to an HSC and the option is an RA9x, the 62X34-RA kit is required because it contains the required hardware brackets and cable tray.
62X34-RB	If the customer already has one embedded storage option (RA9x or SA7x) in the VAX 6000 cabinet connected to an HSC, wants to connect a second option, and the second option is an RA9x, the 62X34-RB kit is required. The 62X34-RB kit does not contain the hardware brackets and cable tray needed only for connecting the first embedded storage option to an HSC.

WARNING

Installation of and all maintenance related to 62X34-SA/-SB and 62X34-RA/-RB Kits must be performed by qualified Digital Customer Service Engineers.

Digital customer access to VAX 6000 Embedded Storage Options is limited to access of RA9x and SA7x operator control panels (OCPs) through the access slot in the system cabinet front door. Access to VAX 6000 Embedded RA9xs, SA7xs, or associated hardware or cables through system cabinet front or rear doors is prohibited.

2.2 62X34-SA/-SB Kit Contents

The 62X34-SA/-SB Kit is required for connecting and dual porting VAX 6000 Embedded SA7x-LKs and SA7x-MKs to HSCs. 62X34-SA/-SB contents are listed in Table 1-1. Ensure that all contents of the kit are present before starting installation procedure.

Table 2–1: 62X34-SA/-SB Kit Parts List

Part Number	Description	-SA Qty	-SB Qty
70-28506-01	New cable tray	1	-
74-41166-01	Bracket, left	1	-
70-27841-01	Bracket weldment, right	1	-
17-01699-01	SA7x I/O cable assembly	2	2
90-00001-21	10-32 male/female hex standoff, 1"	6	6
90-07091-00	Cable clamp, 1" round	8	8
90-07082-00	Cable clamp, 5/16" round	2	2
90-06662-00	Flat washer	5	5
12-15843-03	3/4" X 3" cable clamp, rect.	1	1
90-06565-00	10-32 nut, hex, external tooth	3	3
90-07651-00	External tooth star washer	10	10
90-00063-41	10-32 x 5/8" posidrive scr.	7	7
90-07880-00	Tie, cable, bundle	10	10
90-09984-00	6-32 cone head screw	32	32
EK-62X34-IN	VAX 6000 CI/Embedded Storage Inst. Manual	1	1

2.3 62X34-RA/-RB Kit Contents

The 62X34-RA/-RB Kit is required for connecting and dual porting VAX 6000 Embedded RA9x-PAs to HSCs. 62X34-RA/-RB contents are listed in Table 1-2. Ensure that all contents of the kit are present before starting installation procedure.

Table 2–2: 62X34-RA/-RB Kit Parts List

Part Number	Description	-RA Qty	-RB Qty
70-28506-01	New cable tray	1	-
74-41166-01	Bracket, left	1	-
70-27841-01	Bracket weldment, right	1	-
17-01482-01	RA9x I/O cable assembly	2	2
90-00001-21	10-32 male/female hex standoff, 1"	6	6
90-07091-00	Cable clamp, 1" round	8	8
90-07082-00	Cable clamp, 5/16" round	2	2
90-06662-00	Flat washer	5	5
12-15843-03	3/4" X 3" cable clamp, rect.	1	1
90-06565-00	10-32 nut, hex, external tooth	3	3
90-07651-00	External tooth star washer	10	10
90-00063-41	10-32 x 5/8" posidrive scr.	7	7
90-07880-00	Tie, cable, bundle	10	10
90-09984-00	6-32 cone head screw	32	32
EK-62X34-IN	VAX 6000 CI/Embedded Storage Inst. Manual	1	1

2.4 BC26V Cables

The installation of BC26V SDI Cables is also described in this manual but the BC26V SDI Cables are not provided as part of either kit and must be ordered separately by the customer. BC26V SDI cables must be no less than 12ft. (3.7m) long.

WARNING

BC26V Cable installation must be performed by qualified Digital Customer Service engineers.

Chapter 3

Installing the 62X34-SA/-SB and 62X34-RA/-RB Kit Hardware

3.1 Introduction

This chapter describes how to perform the following:

- Power down the VAX 6000 series processor cabinet
- Install the 62X34-SA/-SB (or 62X34-RA/-RB) Kit hardware including the cable tray/bulkhead left bracket, right bracket, and loose piece hardware required for effective cable management.

WARNING

These procedures must be performed by qualified Digital Customer Service engineers only. Digital customers must not open the VAX 6000 series cabinet front or rear doors or access the enclosures, power supplies, controllers, or fans. All maintenance and repair actions must be performed by a qualified Digital Customer Service engineer.

3.2 Powering Down the VAX 6000 Series Cabinet

The VAX 6000 series processor cabinets use H405 power controllers. To remove power from the cabinet, use the following procedure:

1. Locate the cabinet control panel in the upper-left corner of the front door.
2. With the console key, turn the Standby/Enable/Secure control switch to 0.
3. Turn the Update/Halt/Auto Start control switch to Halt.

It is important to understand that at this point in time power has NOT been removed from the VAX 6000 cabinet - the H405 power controller must be turned off as described in steps 4 through 7 before power is removed from the VAX 6000 cabinet.

4. Go to the rear of the cabinet.

5. Locate the H405 power controller in the lower right hand rear corner of the VAX 6000 cabinet.
6. Remove power from the cabinet by pulling the power controller main circuit breaker T-handle located on the H405 power controller.
7. Unplug the cabinet power cord from the ac receptacle.

3.3 Installing 62X34-SA/-SB and 62X34-RA/-RB Kit Hardware

62X34-SA/-SB and 62X34-RA/-RB VAX 6000 CI/Embedded Storage Kits contain different I/O cables.

- The 62X34-SA/-SB Kits each include two 17-01699-01 SA7x I/O cables required for connecting and/or dual porting VAX 6000 Embedded SA7xs to HSC(s).
- The 62X34-RA/-RB Kits each include two 17-01482-01 RA9x I/O cables required for connecting and/or dual porting VAX 6000 Embedded RA9xs to HSC(s).

Installing the hardware common to both kits is described in this chapter.

3.4 Preparing the VAX 6000 System Cabinet for 62X34 Kit Installation

To prepare the VAX 6000 series System Cabinet for 62X34 Kit installation:

1. Unlock the rear cabinet door with a 5/32 hex door key.
2. Remove the rear door to cabinet frame ground strap.
3. Pull up and lock top door key pin in the upper position.
4. Swing door away from the cabinet and lift it out of the bottom hinge.
5. Remove the door and set aside.

3.5 Installing Mounting Brackets and Cable Tray

The 62X34-SA and 62X34-RA Kits contains a left mounting bracket (74-41166-01), right mounting bracket (70-27841-01), and cable tray (70-28506-01) that must be mounted in the rear of the VAX 6000 cabinet. The embedded storage IO cables and BC26V cables are connected at the cable tray.

3.5.1 Installing the Left Mounting Bracket

To install the left mounting bracket, use the following procedure and refer to Figure 3.1.

1. Remove the two lower 1/2 inch screws (90-00063-39) securing the I/O blower panel at the left rear of the VAX 6000 cabinet.
2. Carefully set the two 1/2 inch screws aside. They must be used for installing the cable tray (3.5.3).
3. Secure the left mounting bracket (74-41166-01) to the VAX 6000 cabinet using two 10/32 x 5/8 screws (90-00063-41).

4. Torque screws to 30 in/lbs.

3.5.2 Installing the Right Mounting Bracket

To install the right mounting bracket, use the following procedure and refer to Figure 3.1.

1. Remove the four screws (90-00063-39) securing the cable guide on the right rear of the VAX 6000 cabinet.
2. Using the same four screws, secure the new right mounting bracket (70-27841-01) to the same location the cable guide was removed from.
3. Torque screws to 30 in/lbs.

3.5.3 Installing the Cable Tray

To install the cable tray, use the following procedure and refer to Figure 3.1.

1. Align the cable tray (70-28506-01) into the tabs on the previously installed left and right mounting brackets.
2. Secure the cable tray to the left and right mounting brackets using the two 1/2 inch screws that were set aside when the left mounting bracket was installed (reference procedure 3.5.1, step 1).

Figure 3-1: Bracketry Installation for the CI Embedded Storage kit

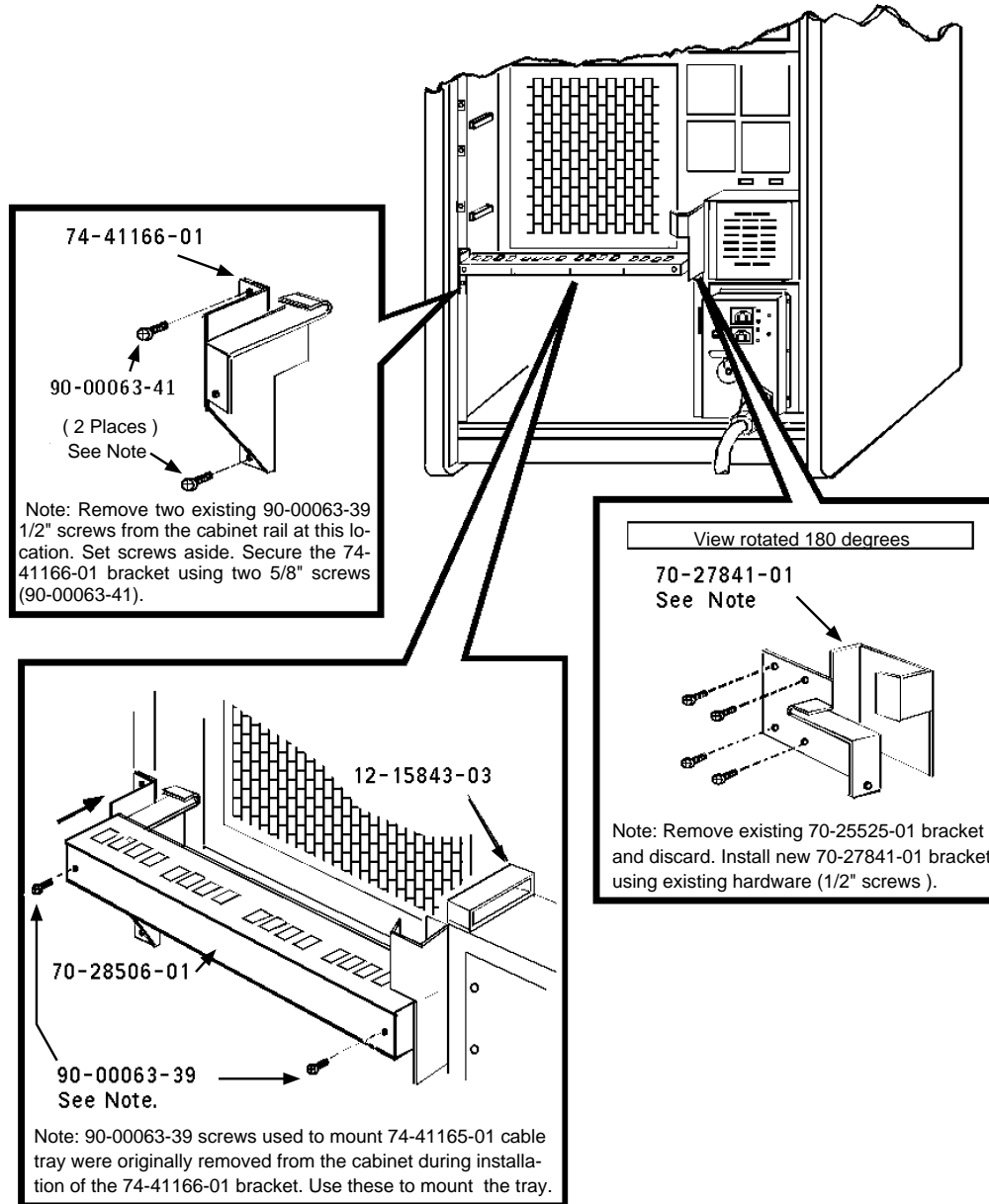

TWO-00001-92.PS

3.6 Installing Cable Routing Hardware

Note:

A number of cable clamps, standoffs, and associated loose screws and washers needed for routing BC26V cables to the cable tray must be installed in the rear of the VAX 6000 cabinet. If this hardware is not properly installed, effective cable connection and management will be next to impossible.

Procedures for installing hardware for embedded SA7xs is contained in 3.6.1 and procedures for installing hardware for embedded RA9xs is contained in 3.6.2.

Note: More loose piece mounting hardware is required for SA7x (62X34-SA/SB kits) cable management because up to a maximum of 16 BC26V cables can be connected in a configuration that includes 2 embedded SA7xs with all 16 ports connected to HSCs; a maximum of only 4 BC26V HSC connections is possible with 2 embedded RA9xs (62X34-RA/RB kits).

The same amount of cable routing hardware is included in all four 62X34 CI embedded storage kits, actual hardware used depends on what configuration is installed.

3.6.1 Installing 62X34-SA/SB Kit Cable Routing Hardware

To install the 62X34-SA/SB kit cable routing hardware required for embedded SA7xs, use the following procedure and refer to Figure 3.2.

1. Mount one 1 inch male/female hex standoff (90-00001-21) and one external star washer (90-07651-00) each to holes #5 and #14 on the left/rear/vertical cabinet rail as shown in Figure 3.2.

Note:

With an SA7x installed in the left/rear side of the VAX 6000 cabinet, Holes #5 and #14 are the only available access holes to the threaded barnuts on the SA7x mounting rail assembly.

If an SA7x is not installed in the left/rear side of the VAX 6000 cabinet, two (2) 10-32 hex nuts (90-06565-00) must be used to secure the two (2) standoffs to the left/rear vertical cabinet rail.

2. Assemble and secure the following parts in order (as shown in the Figure 3.2 upper right call-out) to the standoffs mounted in holes #5 and #14 on the left/rear/vertical cabinet rail.
 - external star washer (90-07651-00)
 - 1 inch cable clamp (90-07091-00)
 - male/female hex standoff (90-00001-21)
 - external star washer (90-07651-00)
 - two 1 inch cable clamps (90-07091-00) mounted back to back
 - flat washer (90-06662-00)

- 10-32 x 5/8 inch posidrive screw (90-00063-41)
3. Mount one 1 inch male/female hex standoff (90-00001-21) and one external star washer (90-07651-00) each to holes #5 and #14 on the right/rear/inside vertical cabinet rail (adjacent to the H405 power controller as shown in Figure 3.2).

Note:

With an SA7x installed adjacent to the H405, holes #5 and #14 are the only available access holes to the threaded bar nuts on the SA7x mounting rail assembly.

If an SA7x is not installed adjacent to the H405, two 10-32 hex nuts (90-06565-00) must be used to secure the two standoffs to the right/rear vertical cabinet rail.

4. Assemble and secure the following parts in order (as shown in the Figure 3.2 lower left call-out) to the standoffs mounted in holes #5 and #14 on the right/rear vertical cabinet rail.
 - external star washer (90-07651-00)
 - 1 inch cable clamp (90-07091-00)
 - flat washer (90-06662-00)
 - 10-32 x 5/8 inch posidrive screw (90-00063-41)
5. Remove the 10-32 x 1 1/4 inch pan head screw holding the lower rear retainer bracket (locking bracket) on the rear of the SA7x.
6. Position two 5/16 inch cable clamps (90-07082-00) on the plastic wedge part of the retainer bracket and mount them with the 10-32 x 1 1/4 inch pan head screw (removed in step 5) and a flat washer (90-06662-00) to hole #2 of the right/rear vertical cabinet as shown in the right call-out in Figure 3.2.

Note: More loose piece mounting hardware is required for SA7x (62X34-SA/SB kits) cable management because up to a maximum of 16 BC26V cables can be connected in a configuration that includes 2 embedded SA7xs with all 16 ports connected to HSCs; a maximum of only 4 BC26V HSC connections is possible with 2 embedded RA9xs (62X34-RA/RB kits).

The same amount of cable routing hardware is included in all four 62X34 CI embedded storage kits, actual hardware used depends on what configuration is installed.

Figure 3-2: SA7x Cable Routing Hardware Installation for CI Embedded Storage Kit.

NOTE 1: SA7x cabling hardware shown mounts at holes 5 and 14 in the 2 unused 10-32 holes of the existing barnut (barnut is part of the SA7x chassis rail assembly).

If no option (SA7x) is mounted at either location, hex nuts (90-06565-00) must be used to secure the hardware to the cabinet (shown in this illustration).

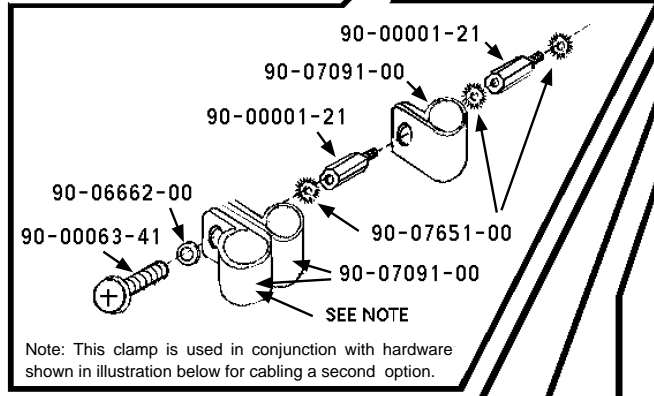
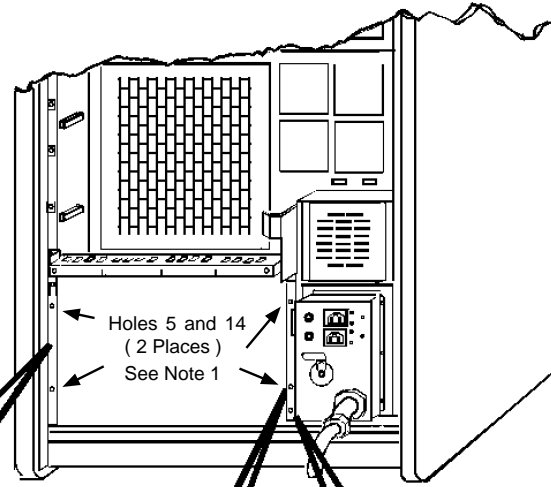

Note: This clamp is used in conjunction with hardware shown in illustration below for cabling a second option.

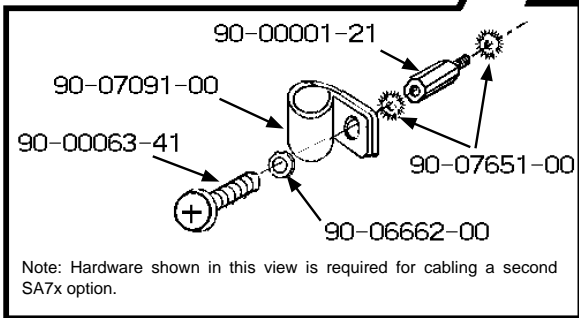

Note: Hardware shown in this view is required for cabling a second SA7x option.

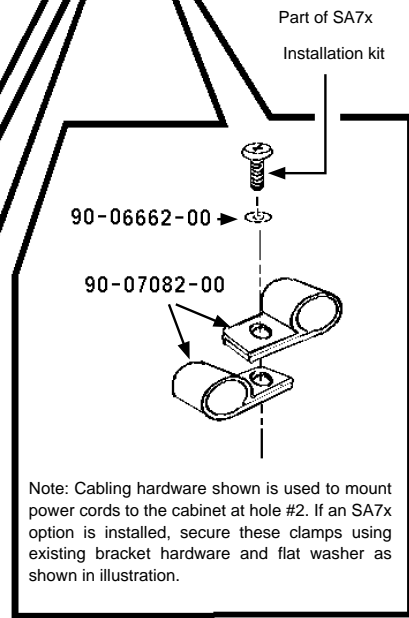

Note: Cabling hardware shown is used to mount power cords to the cabinet at hole #2. If an SA7x option is installed, secure these clamps using existing bracket hardware and flat washer as shown in illustration.

TWO-00002-92.PS

3.6.2 Installing 62X34-RA/RB Kit Cable Routing Hardware

To install the 62X34-RA/RB kit cable routing hardware required for embedded RA9xs, use the following procedure and refer to Figure 3.3.

1. Mount one 1 inch male/female hex standoff (90-00001-21) and one external star washer (90-07651-00) each to holes #5 and #14 on the left/rear/vertical cabinet rail as shown in Figure 3.3.

Figure 3-3: RA9x Cable Routing Hardware Installation for CI Embedded Storage Kit.

NOTE: RA9x cabling hardware shown mounts at holes 5 and 14 in the unused 10-32 holes of the existing barnut (barnut is part of the RA9x chassis assembly).

If no option (RA9x) is mounted at either location, hex nuts (90-06565-00) must be used to secure the hardware so the cabinet (shown in this illustration).

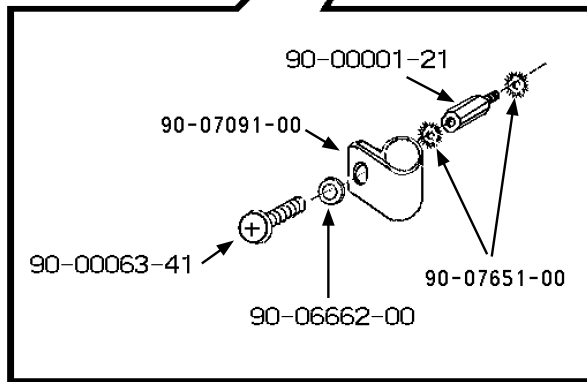
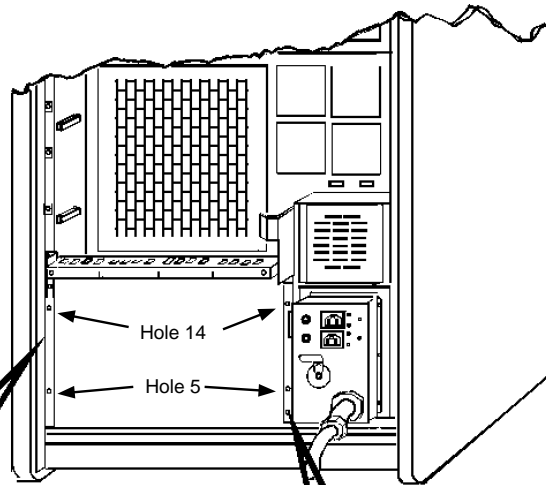

Note: Hardware orientation is illustrated from the left side of the cabinet as viewed from the rear. When installing hardware on the right side (nearest to the H405 Power Controller), position the cable clamp (90-07091-00) inward toward the center of the cabinet.

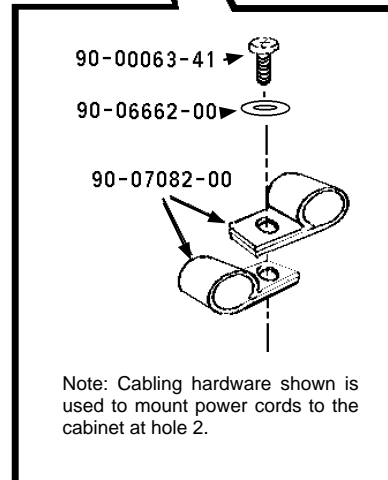

Note: Cabling hardware shown is used to mount power cords to the cabinet at hole 2.

TWO-00003-92.PS

Note:

With an RA9x installed in the left/rear side of the VAX 6000 cabinet, Holes #5 and #14 are the only available access holes to the threaded barnuts on the SA7x mounting rail assembly.

If an RA9x is not installed in the left/rear side of the VAX 6000 cabinet, two (2) 10-32 hex nuts (90-06565-00) must be used to secure the two (2) standoffs to the left/rear vertical cabinet rail.

2. Assemble and secure the following parts in order (as shown in the Figure 3.3 left call-out) to the standoffs mounted in holes #5 and #14 on the left/rear/vertical cabinet rail.
 - external star washer (90-07651-00)
 - 1 inch cable clamp (90-07091-00)
 - flat washer (90-06662-00)
 - 10-31 x 5/8 inch posidrive screw (90-00063-41)
3. Position two 5/16 inch cable clamps (90-07082-00) as shown in the Figure 3.3 right call-out and mount them with a 10-32 x 5/8 inch posidrive screw (90-00063-41) and flat washer (90-06662-00) to hole #2 of the right/rear vertical cabinet as shown in the right call-out in Figure 3.3.

Chapter 4

Cable Routing

4.1 Introduction

This chapter describes the following:

- Routing and connecting SA7x and RA9x I/O cables
- Routing and connecting BC26V SDI cables
- Powering up the VAX 6000 series cabinet

4.2 Routing and Connecting SA7x and RA9x I/O Cables

The following cables are the only embedded storage I/O cables that can be used to connected embedded storage options to BC26V SDI cables at the cable tray.

- 17-01699-01 - for connecting SA7xs
- 17-01482-01 - for connecting RA9xs

Directions for routing SA7x and RA9x I/O cables are described in detail in manuals EK-SA7CK-IN-001 (for the SA7x-MK and SA7x-LK) and EK-RA9CK-IN-001 (for the RA9x-PA).

In both manuals, directions are given to route I/O cables to VAX 6000 system KDB50 bulkhead ports. For connections to the cable tray, the cables are mounted the same way except for the final connection as shown in figures 4.2 through 4.9.

The I/O connections at the cable tray are determined by very strict cable configuration rules that are illustrated in figure 4.1 and described below. The cable tray also has a label that describes the appropriate cable connections.

Figure 4-1: SA7x (17-01699-01) or RA9x (17-01482-01) Cable Configurations

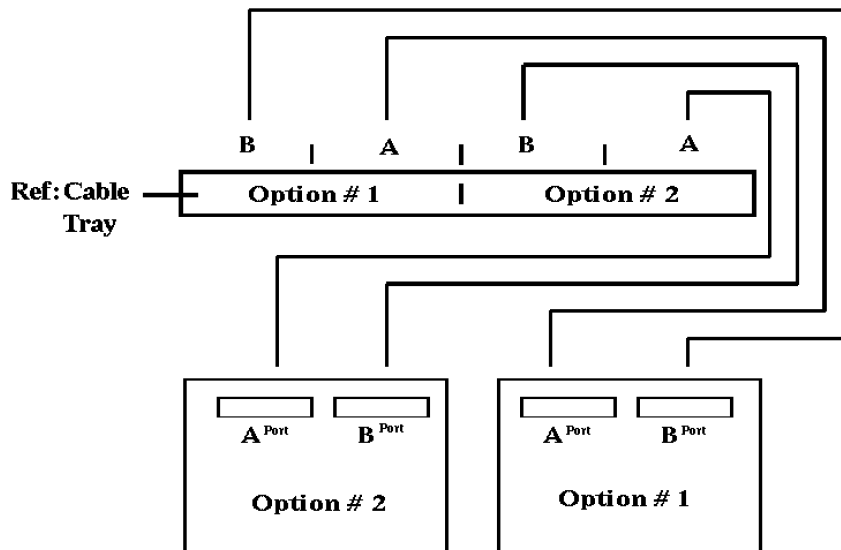

NOTE: This illustration is as viewed from the rear of a 6000 series cabinet.

RR SA70	LR SA70	RF SA70	LF SA70	RR SA70	LR SA70	RF SA70	LF SA70	RR SA70	LR SA70	RF SA70	LF SA70	RR SA70	LR SA70	RF SA70	LF SA70				
RA30				RA30				RA30				RA30							
		B	B Port Option 1				A	A Port Option 1				B	B Port Option 2				A	A Port Option 2	
		1								2							2		

— Ref: Illustration of graphics reflected on the Cable Tray. —

1. Embedded Storage Option #1 (SA7x or RA9x) is located in the space adjacent to the H405 power controller; "A" port cables are routed to the 5th, 6th, 7th, and 8th positions from the left on the top of the cable tray. Option #1/Port "A" SA7x cables are connected according to physical RA70 drive location. The Option #1/port "A" RA9x cable is connected at the 8th position from the left. Refer to Figure 4.1.

Option #1 "B" port cables are routed to the 1st, 2nd, 3rd, and 4th positions from the left on the top of the cable tray. Option #1/Port "B" SA7x cables are connected according to physical RA70 drive location. The Option #1/Port "B" RA9x I/O cable is connected at the 4th position from the left. Refer to Figure 4.1

2. Embedded Storage Option #2 (SA7x or RA9x) is located in the left/ rear/outside space. "A" port cables are routed to the 13th, 14th, 15th, and 16th positions from the left on the top of the cable tray. Option #2/Port "A" SA7x cables are connected according to physical RA70 drive location. The Option #2/Port "A" RA9x is connected at the 16th position from the left. Refer to figure 4.1.

Option #2 "B" port cables are routed to the 9th, 10th, 11th, and 12th positions from the left on the top of the cable tray. Option #2/Port "B" SA7x cables are connected according to physical RA70 drive location. The Option #2/Port "B" RA9x I/O cable is connected at the 12th position from the left. Refer to figure 4.1.

4.3 Routing and Connecting BC26V SDI Cables

BC26V SDI cables must be at least 12 feet long to connect to the cable tray and are connected underneath the cable tray. Refer to Figures 4.2 through 4.9 installation directions on how to mount BC26V cables.

Table 4–1: Cable Configurations

Figure	Drive	Configuration	Page
4.2	Single SA7x	"A" Ported to KDB50	4-7
4.2	Single Sa70	"B" Ported to HSC	"
4.3	Dual SA7xs	"A" Ported to KDB50	4-8
4.3	Dual SA7xs	"B" Ported to HSC	"
4.4	Single SA7x	Dual Ported to HSC(s)	4-9
4.5	Dual SA7xs	Dual Ported to HSC(s)	4-10
4.6	Single RA9x	"A" Ported to KDB50	4-11
4.6	Single RA9x	"B" Ported to HSC	"
4.7	Dual RA9xs	"A" Ported to KDB50	4-12
4.7	Dual RA9xs	"B" Ported to HSC	"
4.8	Single RA9x	Dual Ported to HSC(s)	4-13
4.9	Dual RA9xs	Dual Ported to HSC(s)	4-14

4.3.1 SA7x Configurations

To route BC26V cables to the cable tray (70-28506-01), use the following procedures/configuration rules.

Note: Embedded Storage Option #1 is always mounted adjacent to the H405 Power Controller as illustrated in Figure 4.2. Embedded Storage Option #2 is always mounted along the left/rear/vertical cabinet rail.

4.3.1.1 Single SA7x/single port configurations to an HSC

1. Route the BC26V cables through the lower and upper 1 inch cable clamps (90-07091-00 - Figure 3.2) mounted closest to the left/rear /vertical cabinet rail (Figure 4.2).
2. Connect SA7x Option #1 "A" port connections at the 5th, 6th, 7th, and 8th positions from the left on the underside of the cable tray (Figures 4.1 and 4.2).
3. Connect SA7x Option #1 "B" port connections at the 1st, 2nd, 3rd, and 4th positions from the left on the underside of the cable tray (Figures 4.1 and 4.2).

4.3.1.2 Dual SA7x/single port configurations

1. Route the BC26V cables that will be connected to SA7x Option #2 through the lower and upper 1 inch cable clamps (90-07091-00 - Figure 3.2) mounted closest to the left/rear/vertical cabinet rail (Figure 4.3).
2. Route the BC26V cables that will be connected to SA7x Option #1 through the lower and upper 1 inch cable clamps (90-07091-00 - Figure 3.2) piggy-backed in the middle on the left/rear/vertical cabinet rail (Figure 4.3).
3. Connect the BC26V cables on the underside of the cable tray at the appropriate port/position (Figures 4.1 and 4.3).

4.3.1.3 Single SA7x/dual port configurations

1. Route the BC26V cables that will be connected to the SA7x "B" ports through the lower and upper 1 inch cable clamps (90-07091-00 - Figure 3.2) mounted closest to the left/rear/vertical cabinet rail (Figure 4.4).
2. Route the BC26V cables that will be connected to the SA7x "A" ports through the lower and upper 1 inch cable clamps (90-07091-00 - Figure 3.2) piggy-backed in the middle on the left/rear/vertical cabinet rail (Figure 4.4).
3. Connect the BC26V cables on the underside of the cable tray at the appropriate port/position (Figures 4.1 and 4.4).

4.3.1.4 Dual SA7x/dual port configurations

1. Route the BC26V cables that will be connected to SA7x Option #1 "B" ports through the lower and upper 1 inch cable clamps (90-07091-00 - Figure 3.2) mounted closest to the left/rear/ vertical cabinet rail (Figure 4.5).
2. Route the BC26V cables that will be connected to SA7x Option #1 "A" ports through the lower and upper 1 inch cable clamps (90-07091-00 - Figure 3.2) piggy-backed in the middle on the left/rear/vertical cabinet rail (Figure 4.5).
3. Route the BC26V cables that will be connected to SA7x Option #2 "B" ports through the lower and upper 1 inch cable clamps (90-07091-00 - Figure 3.2) piggy-backed on the outside on the left/rear/vertical cabinet rail (Figure 4.5).
4. Route the BC26V cables that will be connected to SA7x Option #2 "A" ports through the lower and upper 1 inch cable clamps (90-07091-00 - Figure 3.2) mounted adjacent to the H405 power controller (Figure 4.5).
5. Connect the BC26V cables on the underside of the cable tray at the appropriate port/position (Figures 4.1 and 4.5).

4.3.1.5 RA9x Configurations

To route BC26V cables to the cable tray (70-28506-01) for RA9x embedded storage configurations, use the following procedures/configuration rules.

1. For all RA9x only configurations (1 or 2 RA9xs), route the BC26V cable(s) through the lower and upper 1 inch cable clamps (90-07091-00 - Figure 3.3) mounted to the left/rear/vertical cabinet rail (Figures 4.6 - 4.9).
2. Connect the BC26V cable(s) on the underside of the cable tray at the appropriate port/position (Figures 4.1 and 4.6 - 4.9).

4.3.1.6 Mixed SA7x/RA9x Configurations

The following configuration rules should be followed when routing and connecting BC26V cables for mixed SA7x/RA9x embedded storage configurations.

1. Route the BC26V cable(s) that will be connected to Option #1 "B" port(s) through the lower and upper 1 inch cable clamps mounted closest to the left/rear/vertical cabinet rail (Figure 3.2).
2. Route the BC26V cable(s) that will be connected to Option #1 "A" port(s) through the lower and upper 1 inch cable clamps piggy-backed in the middle on the left/rear/vertical cabinet rail (Figure 3.2).
3. Route the BC26V cable(s) that will be connected to Option #2 "B" port(s) through the lower and upper 1 inch cable clamps piggy-backed on the outside on the left/rear/vertical cabinet rail (Figure 3.2).
4. Route the BC26V cable(s) that will be connected to Option #2 "A" port(s) through the lower and upper 1 inch cable clamps mounted adjacent to the H405 power controller (Figure 3.2).

5. Connect the BCV26V cables on the underside of the cable tray (70-28506-01) at the appropriate port/position (Figures 4.1 and 4.5).

4.3.2 Preparing the VAX 6000 System Cabinet for Powering Up

To prepare the VAX 6000 System Cabinet for powering up:

1. Position the rear cabinet door on the rear cabinet hinges.
2. Push and lock both hinge pins down into the hinges.
3. Swing the rear cabinet door into the closed position.
4. Lock the rear cabinet door with a 5/32 hex door key.

4.3.3 Powering Up the VAX 6000 System Cabinet

To apply power to the system cabinet after installation, use the following procedures.

1. Plug the system cabinet power controller into an ac wall receptacle.
2. Push in the main circuit breaker T-handle (ON position) located on the H405 power controller.
3. Locate the system cabinet control panel in the upper-left corner of the system cabinet front door.
4. Turn the Standby/Enable/Secure control switch to Enable.
5. Turn the Update/halt/Auto Start control switch to Auto Start.

4.3.4 Verification of Drive Operation and HSC Connections

To verify VAX 6000 embedded storage option operation and connections to the HSC(s), use the following procedures.

1. Verify operation of the VAX 6000 embedded storage options by following the procedures included in the SA7x/VAX 6000 Cabinet Series Upgrade Installation Guide (EK-SA7CK-IN-001) and the RA9x/VAX 6000 Cabinet Series Upgrade Installation Guide (EK-RA9CK-IN-001).
2. Verify physical connection of the BC26V cables at the HSC(s). Reference the HSC Installation Manual (EK-HSCMN-IN-001) for any necessary information related to BC26V cable connections at the HSC.
3. Verify proper operation of the CI/Embedded Storage configuration by running diagnostic ILDISK from the HSC. Reference the HSC Service Manual (EK-HSCMA-SV-002) for any information related to running this or other diagnostics.

Figure 4-2: Single SA7x...A Ported to KDB50...B Ported to a HSC

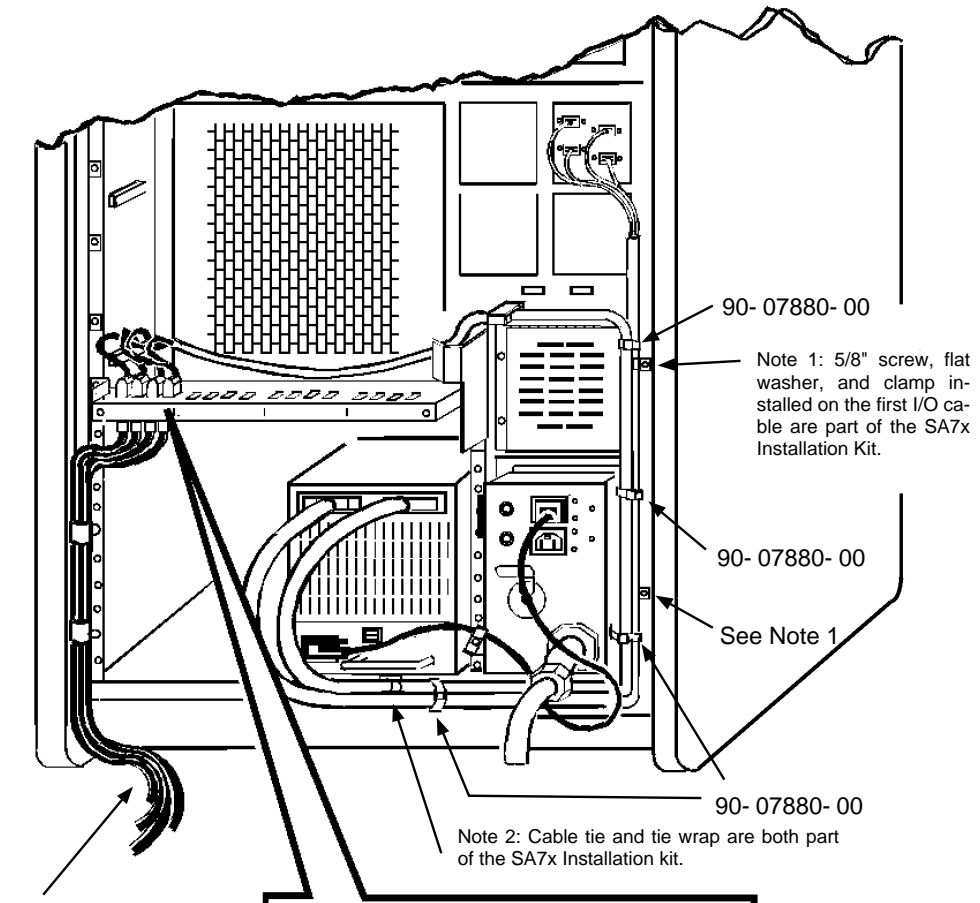

Note 3: BC26V cables are shown here for illustration purposes only. Cables are Field Installed.

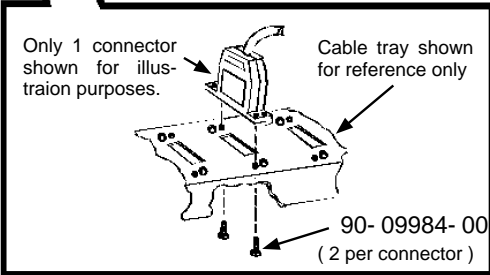

TWO-00004-92.PS

Figure 4-3: Dual SA7xs...A Ported to KDB50...B Ported to a HSC

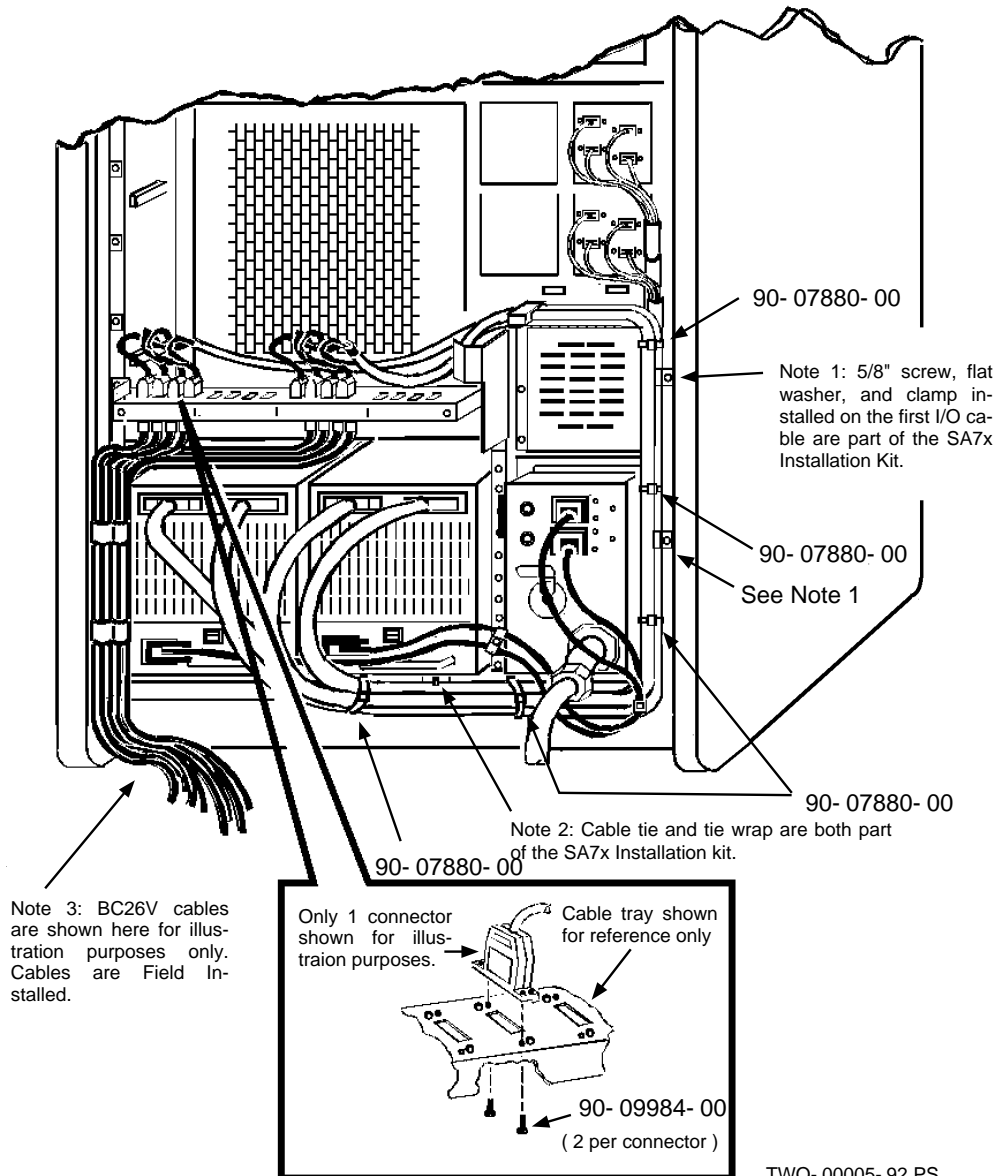

Figure 4-4: Single SA7x...A and B Ported to a HSC

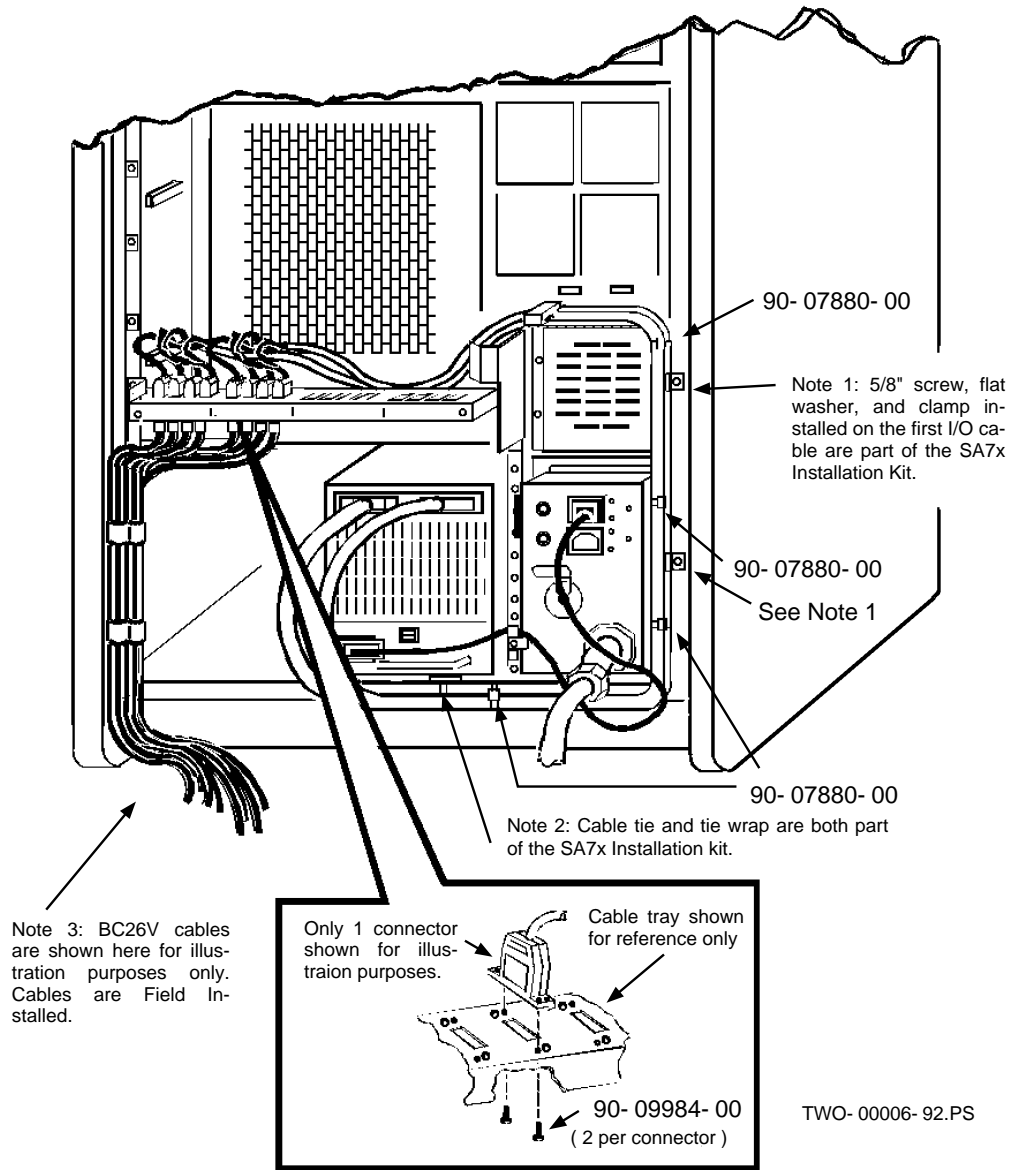
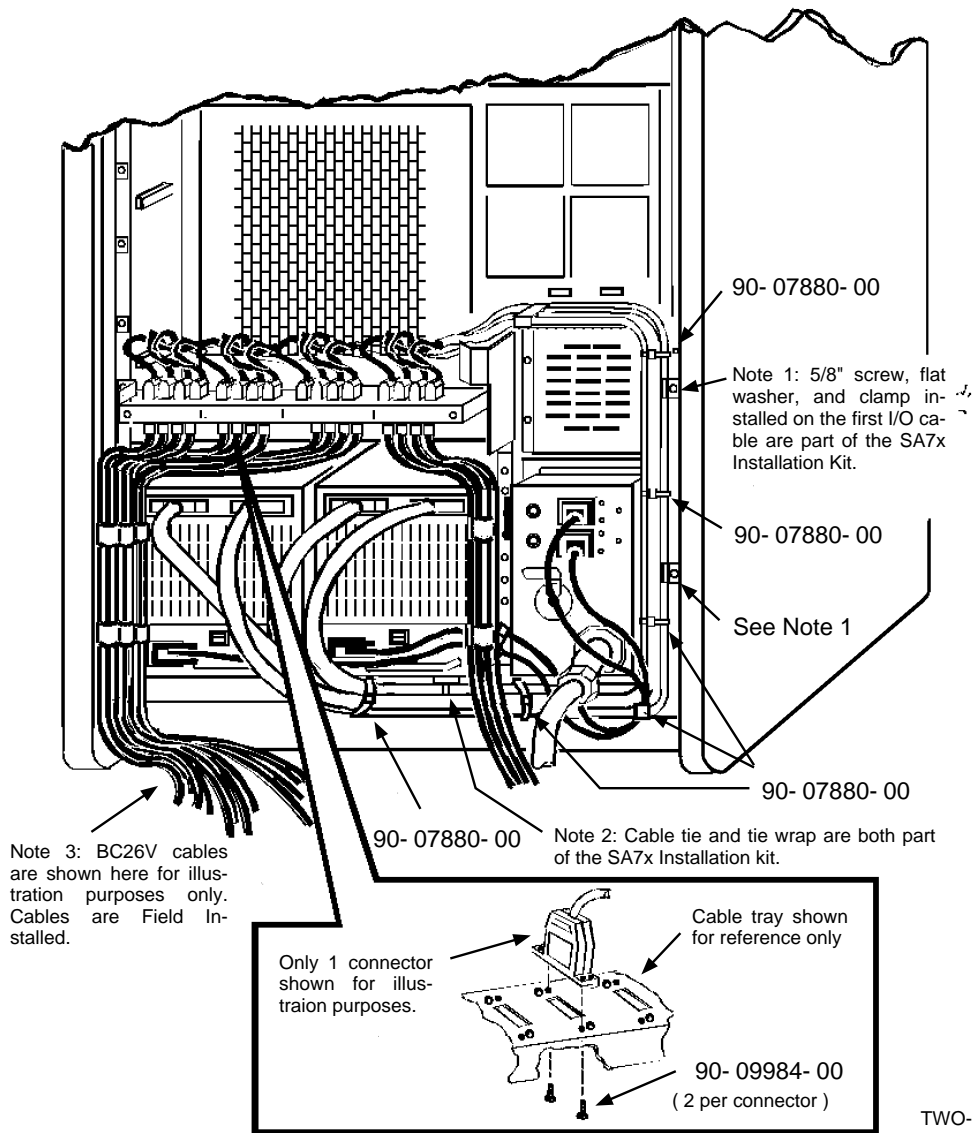

Figure 4-5: Dual SA7xs...A and B Ported to a HSC



TWO-00007-92.PS

Figure 4-6: Single RA9x...A Ported to KDB50...B Ported to a HSC

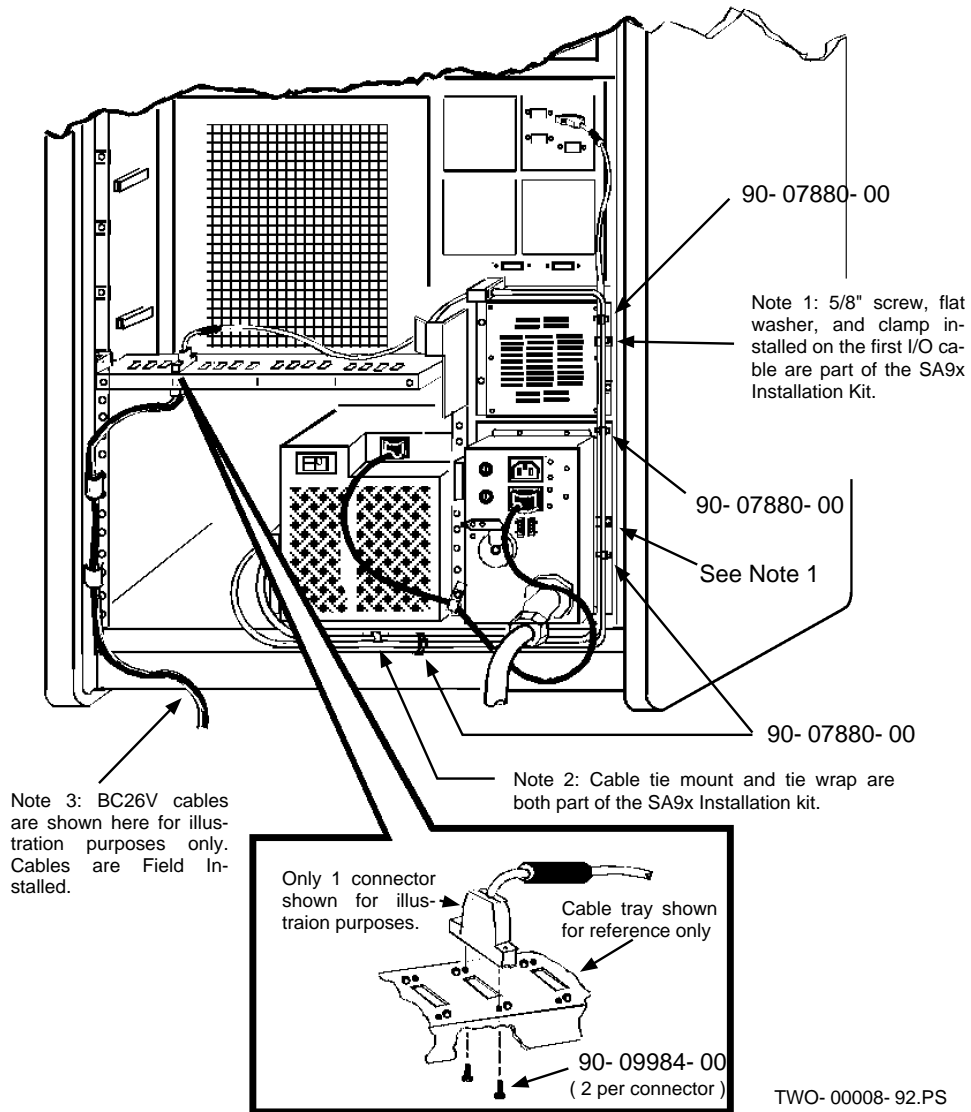

Figure 4-7: Dual RA9xs...A Ported to KDB50...B Ported to a HSC

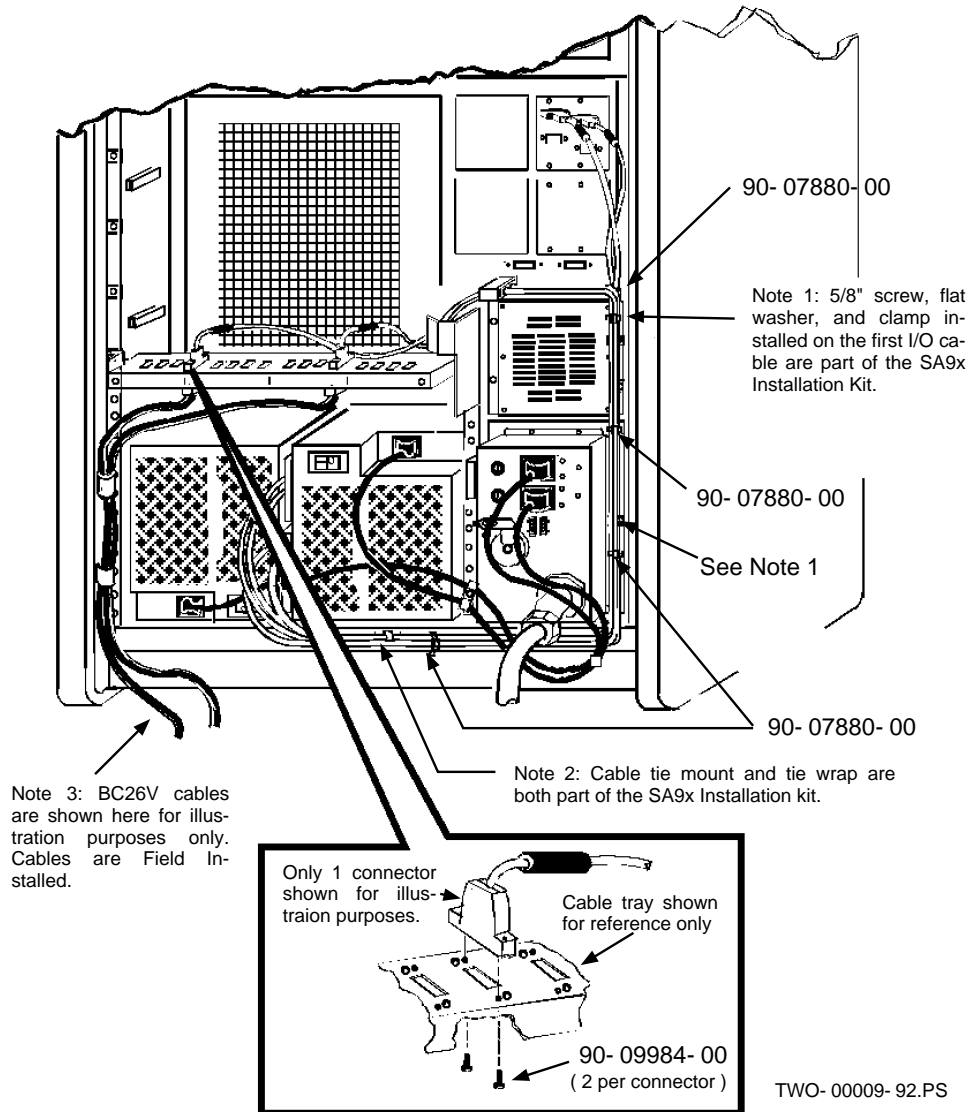

Figure 4-8: Single RA9x...A and B Ported to a HSC

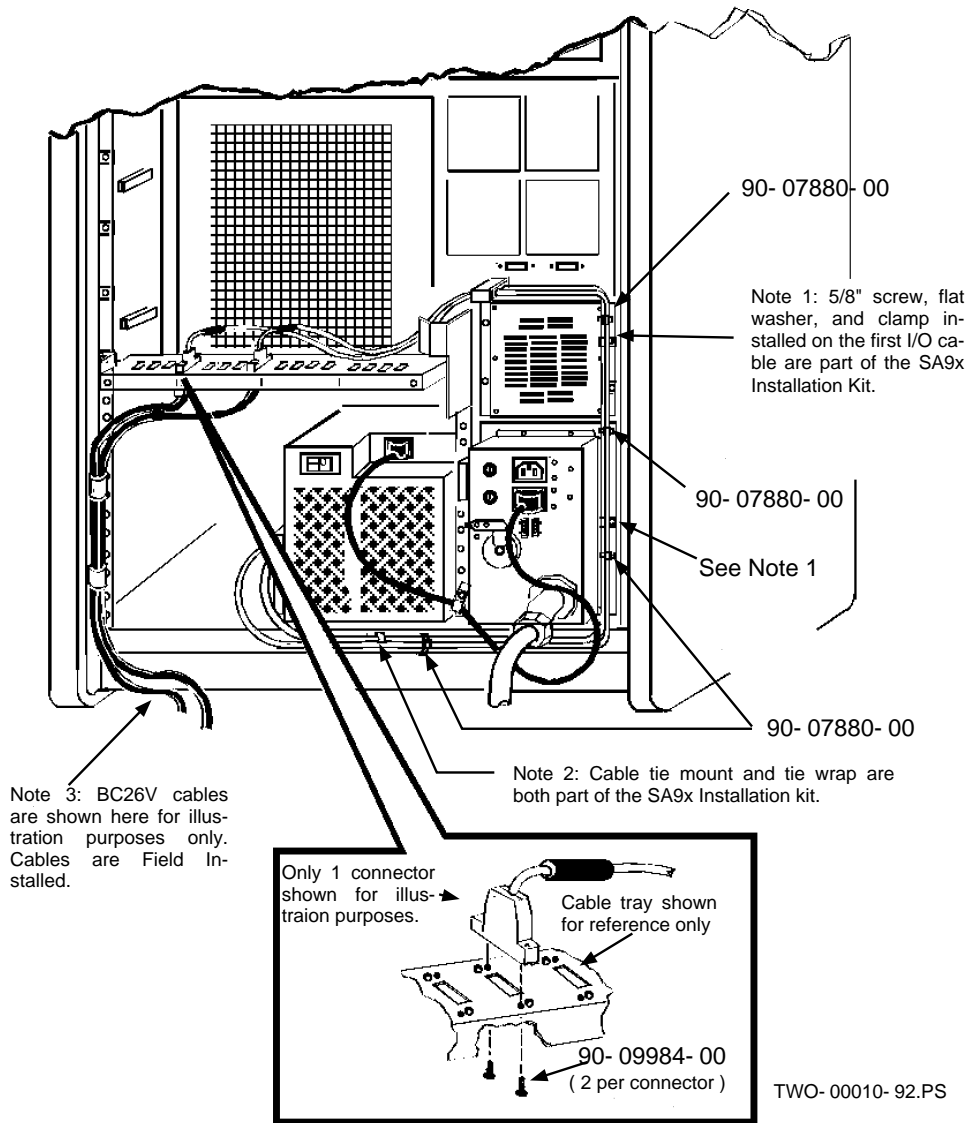
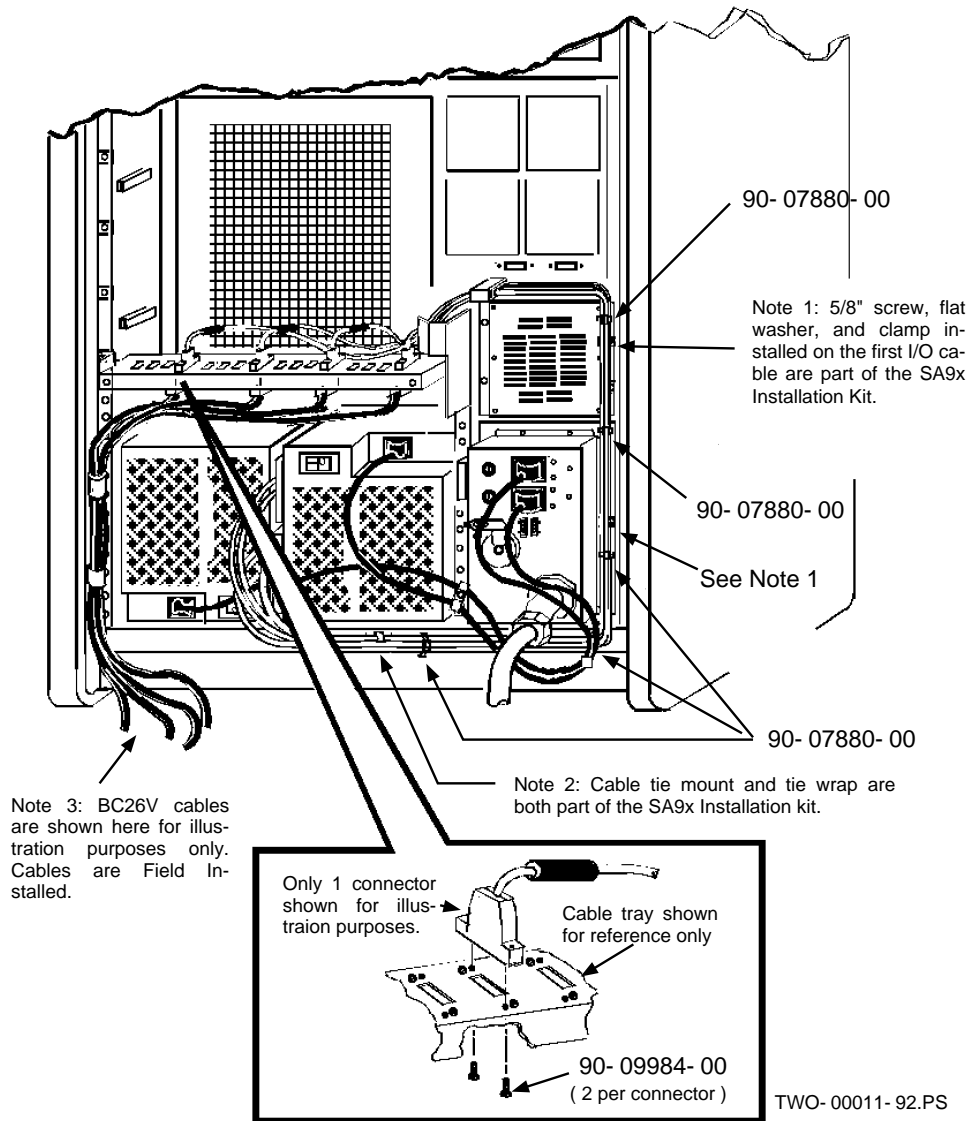

Figure 4–9: Dual RA9xs...A and B Ported to a HSC



Chapter 5

VAX 6000 Embedded Storage Documentation

5.1 Introduction

This chapter describes documentation related to connecting 6000 embedded storage options to HSCs.

5.2 6000 Embedded Storage and Related HSC Manuals

The following table includes all 6000 embedded storage manuals (including one document) and two HSC Manuals that contain information related to connecting 6000 embedded storage options to HSCs.

Table 5–1: Related Documentation

Manual	Description
<i>EK-SA7CK-IN-001</i>	SA7x/6000 Cabinet Series Upgrade Installation Guide included with SA7x-MK and SA7x-LK options. Describes installation of SA7x-MK and SA7x-LK embedded storage options into 6000 System cabinet and operation of the options.
<i>EK-RA9CK-IN-001</i>	RA9x/6000 Cabinet Series Upgrade Installation Guide included with RA9x-PA options. Describes installation of RA9x-PA embedded storage option into 6000 System cabinet and operation of the option.
<i>EK-62X34-IN</i>	VAX 6000 CI/Embedded Storage Manual included with 62X34-SA, SB, RA, and RB 6000 CI/Embedded Storage kits. Describes installation of hardware and cabling necessary to support 6000 embedded storage option(s) connection to HSC(s).
<i>EK-62X34-CL-001</i>	VAX 6000 Series Embedded Storage Cover Letter included with 62X34-UA and 62X34-UB Upgrade kits. Includes information necessary for any embedded storage upgrade that includes installation of unswitched H405 power controllers and 70-26931-01 doors.

Table 5–1 (Cont.): Related Documentation

Manual	Description
<i>EK-HSCMN-IN-001</i>	HSC Installation Manual Describes installation of HSCs including information related to connecting BC26V cables to HSCs.
<i>EK-HSCMA-SV-002</i>	HSC Service Manual Describes servicing HSCs including information on the ILDISK diagnostic necessary to verify HSC/6000 embedded storage connection and operation.

Index

C

Cable Routing

- BC26V SDI Cables, 4-3
- Dual SA7x, Dual Port, 4-4
- Dual SA7x, Single Port, 4-4
- RA9x, 4-1
- RA9x Configurations, 4-5
- SA7x, 4-1
- Single SA7x, Dual Port, 4-4
- Single SA7x, Single Port, 4-4

Cable Routing Hardware, 3-5

Cables, SDI, 2-3

Cable Tray, 3-2

Configuration

- Mixed SA7x/RA9x, 4-5

E

ESD Precautions, 1-1

H

Hazards and Safety Precautions, 1-1

I

Installation

- Cable Routing Hardware, 3-5
- Cable Tray, 3-2
- Mounting Brackets, 3-2
- RA9x Cable Routing, 3-8
- SA7x Cable Routing, 3-5

K

Kit Installation, 3-2

M

Mounting Brackets, 3-2

P

Power Down Procedure, 3-1

R

-RA/-RB Kit Contents, 2-2

Related Documentation, 5-1

S

-SA/-SB Kit Contents, 2-2

SA7x/SA9x Kits, 2-1

SA7x Kits, 2-1

Safety Precautions and Hazards, 1-1

SDI Cables, 2-3

V

VAX 6000 Cab Preparation, 3-2

VAX 6000 Power Up, 4-6

Verification

- Drive Operation, 4-6
- HSC Connections, 4-6