

# VAX 4000 Model 105A/106A

---

## Customer Technical Information

Order Number: EK-514AA-TI. B01

**May 1995**

This manual provides technical information for VAX 4000 Model 105A/106A systems. It also gives a list of the console commands, and specifications for the system unit, the CPU, the internal SCSI and DSSI devices.

---

**April 1995**

Digital Equipment Corporation makes no representations that the use of its products in the manner described in this publication will not infringe on existing or future patent rights, nor do the descriptions contained in this publication imply the granting of licenses to make, use, or sell equipment or software in accordance with the description.

Possession, use, or copying of the software described in this publication is authorized only pursuant to a valid written license from Digital or an authorized sublicensor.

© Digital Equipment Corporation 1995. All Rights Reserved.

The postpaid Reader's Comments forms at the end of this document request your critical evaluation to assist in preparing future documentation.

The following are trademarks of Digital Equipment Corporation: DECnet, Digital, OpenVMS, RRD42, RRD43, RX, ThinWire, TK, VAX, VAXcluster, VAX DOCUMENT, VT, and the DIGITAL logo.

All other trademarks and registered trademarks are the property of their respective holders.

S2851

This document was prepared using VAX DOCUMENT Version 2.1.

---

# Contents

<b>Preface</b> .....	vii
<b>1 System Description</b>	
1.1 The VAX 4000 Model 105A/106A System Unit .....	1-1
1.1.1 Model 105A/106A VAX Architecture Support .....	1-3
1.2 Internal Mass Storage Devices .....	1-5
1.3 Communications Devices .....	1-6
1.3.1 Asynchronous Communications Devices .....	1-6
1.3.2 Synchronous Communications Devices .....	1-6
<b>2 Console Security Feature and System Defaults</b>	
2.1 Entering Console Mode .....	2-2
2.2 Using the Console Port MMJ 3 .....	2-4
2.3 Console Security Feature .....	2-5
2.3.1 Setting the Security Password .....	2-6
2.3.2 Enabling the Console Security Feature .....	2-7
2.3.3 Logging in to Privileged Console Mode .....	2-7
2.3.4 Changing the Security Password .....	2-8
2.3.5 Disabling the Console Security Feature .....	2-9
2.3.6 Exiting from Privileged Console Mode .....	2-9
2.4 Setting the Default Boot Device .....	2-10
2.5 Setting the Default Recovery Action .....	2-11
<b>3 Console Commands</b>	
3.1 BOOT .....	3-1
3.2 CONTINUE .....	3-3
3.3 DEPOSIT .....	3-3
3.4 EXAMINE .....	3-4
3.5 FIND .....	3-6
3.6 HALT .....	3-6

3.7	HELP .....	3-7
3.8	INITIALIZE .....	3-9
3.9	LOGIN .....	3-10
3.10	MOVE .....	3-11
3.11	NEXT .....	3-12
3.12	REPEAT .....	3-14
3.13	SEARCH .....	3-15
3.14	SET .....	3-17
3.15	SHOW .....	3-18
3.16	START .....	3-21
3.17	TEST .....	3-22
3.18	UNJAM .....	3-26
3.19	X—Binary Load and Unload .....	3-26
3.20	! (Comment) .....	3-28

## 4 Hardware Specifications

4.1	System Unit Specifications .....	4-1
4.2	Internal DSSI Device Specifications .....	4-5
4.3	KA53—AA CPU Specifications .....	4-10
4.4	KA54—AA CPU Specifications .....	4-13

## Index

## Figures

1-1	Block Diagram of the VAX 4000 Model 105A/106A System .....	1-2
2-1	Returning to Console Mode .....	2-3
2-2	Console Port .....	2-4

## Tables

1-1	Supported Internal Mass Storage Devices .....	1-5
1-2	Supported Asynchronous Devices .....	1-6
1-3	Supported Synchronous Devices .....	1-6
1-4	Synchronous Communications Option Cable Part Numbers .....	1-6
2-1	Alternative Default Boot Devices .....	2-10
2-2	Default Recovery Actions and Associated Values .....	2-11

4-1	System Specifications: VAX 4000 Model 105A/106A .....	4-2
4-2	System Unit Metrics .....	4-3
4-3	System Storage Conditions .....	4-3
4-4	System Operating Conditions and Nonoperating Conditions .....	4-3
4-5	DSSI Hard Disk Drive Specifications .....	4-5
4-6	TZ30 Tape Drive Specifications .....	4-6
4-7	TZK10 QIC Tape Drive Specifications .....	4-6
4-8	TZK11 QIC Tape Drive Specifications .....	4-7
4-9	TLZ06 Cassette Tape Drive Specifications .....	4-7
4-10	TLZ07 Cassette Tape Drive Specifications .....	4-8
4-11	RRD42 Compact Disc Drive Specifications .....	4-8
4-12	RRD43 Compact Disc Drive Specifications .....	4-9



---

# Preface

This manual provides technical information for VAX 4000 Model 105A and Model 106A systems. It also gives a list of the console commands, and specifications for the system unit, the CPU, and the SCSI and DSSI devices.

## Audience

This manual is intended for experienced users such as system programmers or system managers.

## Structure of This Manual

This manual has four chapters and an index:

- Chapter 1 describes technical information about the Model 105A/106A systems.
- Chapter 2 describes the console security feature and how to set system defaults.
- Chapter 3 describes the console commands.
- Chapter 4 gives specifications for the system unit and for internal DSSI devices.

## Additional Information

See *VAX 4000 Model 105A/106A Operator Information*, EK-513AA-OP, for the list of associated and related documents.

## Conventions

The following conventions are used in this manual:

Convention	Description
MONOSPACE	Text displayed on the screen is shown in monospace type.
<b>boldface type</b>	Boldface type in examples indicates user input. Boldface type in text indicates the first instance of terms defined either in the text, in the glossary, or both.
<i>italic type</i>	Italic type emphasizes important information, indicates variables, and indicates complete titles of manuals.
<i>nn nnn .nnn nn</i>	A space character separates digits in numerals with 5 or more digits. For example, <i>10 000</i> equals <i>ten thousand</i> .
<i>n .nn</i>	A period in numerals signals the decimal point indicator. For example, <i>1.75</i> equals <i>one and three-fourths</i> .
UPPERCASE	Words in uppercase indicate a command.
lowercase	In format descriptions, words in lowercase indicate parameters or arguments to be specified by the user.
	In command syntax descriptions, a vertical bar   separates similar options, one of which you can choose.
<b>Note</b>	A note contains information of special importance to the reader.
Ctrl/ <i>x</i>	Ctrl/ <i>x</i> indicates that you hold down the Ctrl key while you press another key or mouse button (indicated here by <i>x</i> ).
<i>x</i>	A lowercase italic <i>x</i> indicates the generic use of a letter. For example, <i>xxx</i> indicates any combination of three alphabetic characters.
<i>n</i>	A lowercase italic <i>n</i> indicates the generic use of a number. For example, <i>19nn</i> indicates a 4-digit number in which the last 2 digits are unknown.
{ }	In format descriptions, braces indicate required elements. You must choose one of the elements.
[ ]	In format descriptions, brackets indicate optional elements. You can choose none, one, or all of the options.

# 1

---

## System Description

This chapter gives a technical description of VAX 4000 Model 105A and Model 106A systems, including information on the following subjects:

- Model 105A/106 system unit
- Internal mass storage devices
- Communications devices
- Digital Storage Systems Interconnect (DSSI)
- KA53-AA/KA54-AA CPU specifications

### 1.1 The VAX 4000 Model 105A/106A System Unit

The VAX 4000 Model 105A system uses the KA53 CPU module, while the VAX 4000 Model 106A system uses the KA54 CPU module . These modules contain the following integrated circuit components:

- NVAX: processor chip, with a 333 MHz clock
- NMC: NVAX memory controller
- NCA: NVAX CP bus adapter
- SHAC: DSSI support (KFDDA daughter card)
- CQBIC: Q-bus support
- SCSI controller
- SQWF buffer
- SSC: Time-of-year (TOY) clock
- SGEC: Ethernet controller (DC541)
- QUART: Serial line controller (DC7085)
- Support for up to 128 Mbytes of SIMMs (single-inline memory modules)

- Support for optional asynchronous communications devices, which provide either 8 or 16 additional DEC423 ports, or 8 additional asynchronous modem control ports
- Support for optional synchronous communications devices, using DSW42 and DHW42 options which provide two synchronous ports

Figure 1-1 is a block diagram of the VAX 4000 Model 105A/106A systems.

**Figure 1-1 Block Diagram of the VAX 4000 Model 105A/106A System**

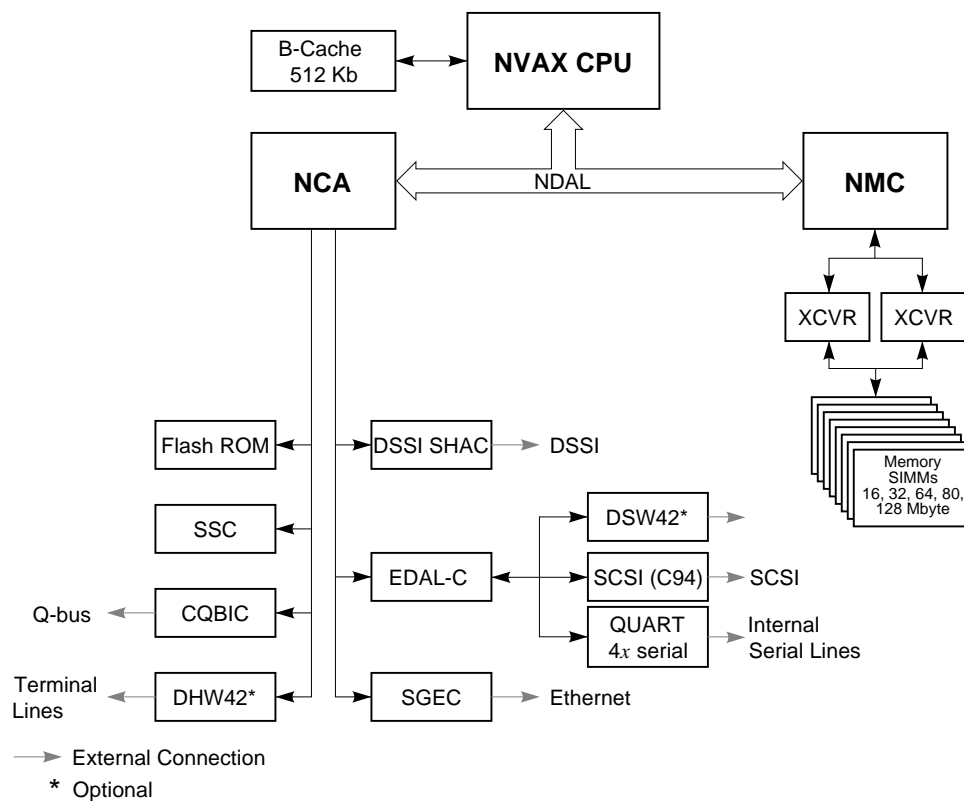

MLO-009354

### 1.1.1 Model 105A/106A VAX Architecture Support

The KA53/KA54 CPU modules support the following VAX data types:

- byte, word, longword, quadword
- character string
- variable-length bit field
- absolute queues
- self-relative queues
- f\_floating point, d\_floating point, and g\_floating point

The operating system uses software emulation to support other VAX data types.

The KA53/KA54 CPU modules support the following VAX instructions:

- integer, arithmetic, and logical
- address
- variable-length bit field
- control
- procedure call
- miscellaneous
- queue
- character string instructions:

- MOVC3/MOVC5
  - CMPC3/CMPC5
  - LOCC
  - SCANC
  - SKPC
  - SPANC

- operating system support
- f\_floating point, d\_floating point, and g\_floating point

The NVAX processor chip provides special microcode assistance to aid the macrocode emulation of the following instruction groups:

- Character string (other than those mentioned previously)
- Decimal string
- CRC
- EDITPC

The operating system uses software emulation to support other VAX instructions.

## 1.2 Internal Mass Storage Devices

Table 1–1 shows the internal mass storage devices that are supported by VAX 4000 Model 105A/106A systems.

**Table 1–1 Supported Internal Mass Storage Devices**

Device	Size (inches)	Capacity (bytes)	Description
RF31T	3.5	381M	Hard disk drive
RF35	3.5	852M	Hard disk drive
RF36	3.5	1.6G	Hard disk drive
TZ30	5.25	95M	Tape drive
TZK10	5.25	320M or 525M	Tape drive
TZK11	5.25	Up to 2.0G	Tape drive
TLZ06	3.5	Up to 4.0G	Tape drive
TLZ07	3.5	Up to 8.0G	Tape drive
RRD42	5.25	600M	CD-ROM drive
RRD43	5.25	600M	CD-ROM drive

The Model 105A/106A systems support a maximum of three internal DSSI devices, and two removable SCSI devices. One of the RF-series disks contains factory installed software (FIS). Chapter 4 gives the specifications for each internal DSSI device.

## 1.3 Communications Devices

The Model 105A/106A systems support asynchronous and synchronous communications devices.

### 1.3.1 Asynchronous Communications Devices

Table 1–2 lists the asynchronous devices supported by Model 105A/106A systems.

**Table 1–2 Supported Asynchronous Devices**

Device	Description
DHW42-AA	Eight-line DEC423 asynchronous option
DHW42-BA	Sixteen-line DEC423 asynchronous option
DHW42-CA	Eight-line EIA-232 modem asynchronous option
DHW42-UP	Eight-line to 16-line upgrade of the DEC423 asynchronous option

### 1.3.2 Synchronous Communications Devices

Table 1–3 lists the synchronous devices supported by Model 105A/106A systems.

**Table 1–3 Supported Synchronous Devices**

Device	Description
DSW42-AA	Two-line EIA-232/V.24 synchronous module

If you order a different synchronous option cable, you can use different interface standards with the synchronous communications module. Table 1–4 lists each standard and the part number of the corresponding option cable.

**Table 1–4 Synchronous Communications Option Cable Part Numbers**

Standard	Option Cable Part Number
EIA-232/V.24	BC19D-02
EIA-423/V.10	BC19E-02
EIA-422/V.11	BC19B-02

# 2

---

## Console Security Feature and System Defaults

This chapter describes how to set system defaults and how to use the console security feature. It includes information on the following subjects:

- Entering console mode
- Using the console port
- Using the console security feature
- Setting the default boot device
- Setting the default recovery action

## 2.1 Entering Console Mode

To use the procedures described in this chapter, the system must be in console mode. To enter console mode, you must shut down the operating system software if it is running. To enter the console mode, follow these steps:

1. Shut down the operating system software if it is running. See the operating system documentation for information on the shutdown procedures.
2. Press the halt button on the back of the system, as shown in Figure 2-1 ❶. The system responds with the console prompt (>>>) on port 3 when it is in console mode.

**Figure 2-1 Returning to Console Mode**

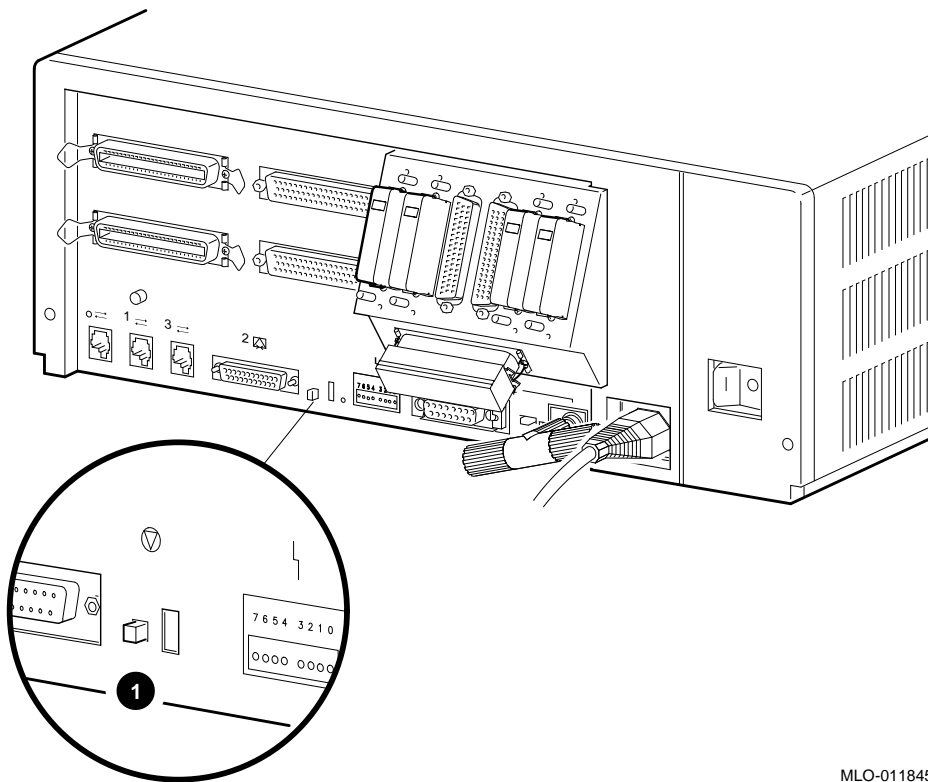

MLO-011845

**1** Halt Button

## 2.2 Using the Console Port MMJ 3

The VAX 4000 Model 105A/106A systems provide a console port through MMJ port 3. Follow these steps:

1. Set the on/off switch on the system unit to the off (O) position.
2. Connect the console terminal to MMJ port 3 (Figure 2-2 ❶).
3. Set the break enable switch (Figure 2-2 ❷) to the up position (break enable).

The break enable LED lights when you set the switch to the up position.

4. Set the on/off switch on the system unit to the on ( | ) position.
5. The system will stop at the console prompt (>>>).

Figure 2-2 Console Port

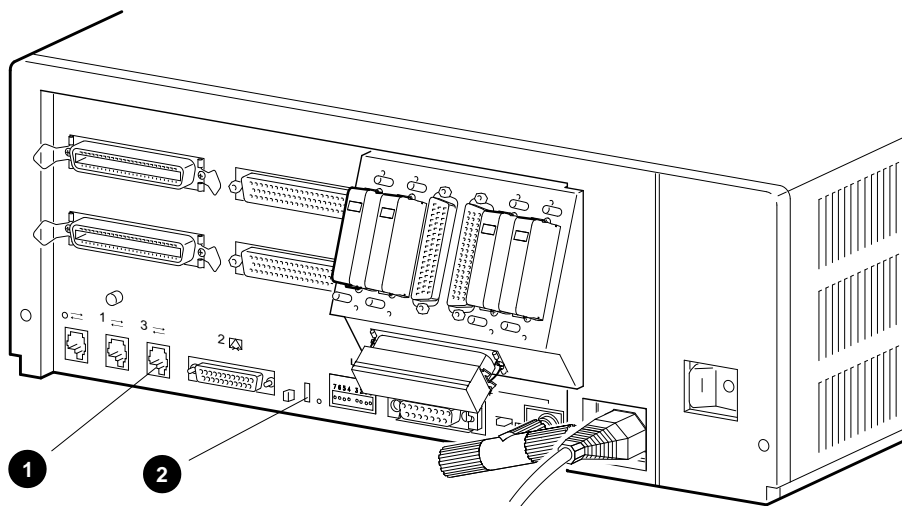

MLO-011846

- ❶ MMJ Port 3, Console Port
- ❷ Break/Enable Switch

## 2.3 Console Security Feature

When the security password is set, there are two types of users: privileged users and unprivileged users. Privileged users know the security password and can use the full range of console commands; unprivileged users can use only the following commands:

- LOGIN—Use this command with the security password to become a privileged user.
- BOOT—Use this command without parameters to boot the operating system when the boot device has been set.

The following subsections describe how to do the following tasks:

- Set the security password
- Enable the console security feature
- Log in to privileged console mode
- Change the security password
- Disable the security password
- Exit from privileged console mode

Chapter 3 describes the console commands.

### 2.3.1 Setting the Security Password

The console security feature is disabled when you receive the system. To set the security password on the system, follow these steps:

1. Enter the following command at the console prompt (>>>):

```
>>> SET PSWD
```

The system responds with the following prompt:

```
>>> PSWD1 :
```

---

**Note**

---

The security password must be a string of **EXACTLY** 16 hexadecimal characters (0 through 9 and A through F).

Write down the security password and store it in a safe place. If you forget the security password, you must call your Digital Services representative to disable the console security feature.

---

2. Enter the security password and press .

The system does not display the security password as you type it. The system responds with the following prompt:

```
>>> PSWD2 :
```

3. Verify the security password by entering it a second time.

Again the system does not display the security password as you type it. If you enter the same security password at each prompt, the system saves the security password in nonvolatile memory. The system does not lose the security password when you turn off the system.

If the second security password does not match the first, the system responds with the following error message:

```
?80 ILLEGAL PASSWORD
```

```
>>>
```

4. Repeat steps 1 to 3 if you see this error message.

## 2.3.2 Enabling the Console Security Feature

When you have set the security password, you must enable the console security feature. To enable the console security feature, enter the following command at the console prompt:

```
>>> SET PSE 1
```

## 2.3.3 Logging in to Privileged Console Mode

When the console security feature is enabled, you must enter the security password to log in to privileged console mode. In privileged console mode you can use the full range of console commands. To log in to privileged console mode, follow these steps:

---

### Note

---

You must set the security password before following these steps (see Section 2.3.1).

---

1. Enter the following command:

```
>>> LOGIN
```

The system responds with the following prompt:

```
>>> Password:
```

2. Enter the security password and press `[Return]`.

The system does not display the security password as you type it. If you enter the correct security password, the system returns you to the console prompt and you become a privileged user. You can now use the full range of console commands.

If you enter an incorrect security password, the system responds with the following error message:

```
?81 INCORRECT PASSWORD
```

```
>>>
```

3. Repeat steps 1 and 2 if an error message displays.

## 2.3.4 Changing the Security Password

You must be a privileged user to change the security password. To change the security password, follow these steps:

1. Follow the procedure in Section 2.3.3 using the current security password to log in to the system.
2. Enter the following command:

```
>>> SET PSWD
```

The system responds with the following prompt:

```
PSWD1 :
```

3. Enter a new security password and press Return.

The system does not display the security password as you type it. The system then responds with the following prompt:

```
PSWD2 :
```

4. Verify the new security password by entering it a second time.

The system does not display the security password as you type it. If you enter the correct, current security password at the >>> prompt, and correctly enter the new security password a second time, the system saves the new security password in nonvolatile memory. The system does not lose the new security password when you turn off the system.

If you incorrectly enter the new security password a second time, the system responds with the following error message:

```
?80 ILLEGAL PASSWORD
```

```
>>>
```

5. Repeat steps 1 to 4 if this error message displays.

### 2.3.5 Disabling the Console Security Feature

When you disable the console security feature, all users can use the full range of console commands. To disable the console security feature, follow these steps:

1. Follow the procedure in Section 2.3.3 using the current security password to log in to the system.
2. Enter the following command:

```
>>> SET PSE 0
```

### 2.3.6 Exiting from Privileged Console Mode

When you exit from privileged console mode, privileged users must enter the LOGIN command with the correct password before they can use the full range of console commands. To exit from privileged console mode, enter one of the following commands:

- BOOT (with any supplied parameters)
- CONTINUE
- HALT
- START

Chapter 3 describes each of these commands.

## 2.4 Setting the Default Boot Device

When the system is shipped, it is set to boot from the system disk, DIA0. This RF-series disk holds the factory installed software (FIS).

If the TOY battery has discharged, the default boot device may have to be set. Use **SHOW BOOT** to verify.

You can set the system to boot from a different default boot device that holds the operating system software. Table 2–1 shows the alternative default boot devices and their associated OpenVMS device names.

**Table 2–1 Alternative Default Boot Devices**

Device	OpenVMS Device Name
Hard disk (DSSI ID 0 to 6)	DIA <u>u</u> <sup>1</sup>
Network (the system boots from a remote system)	EZA0
Tape drive (SCSI ID 0 to 7) <sup>3</sup>	MKAx00 <sup>2</sup>
Compact disc (SCSI ID 0 to 7) <sup>3</sup>	DKAx00 <sup>2</sup>

<sup>1</sup>*u* represents the device unit number.

<sup>2</sup>*x* represents the SCSI ID of that device.

<sup>3</sup>This excludes ID number 6 which is the default controller ID.

To set an alternative default boot device, enter the SET BOOT command using the OpenVMS device name of the alternative default boot device. For example, to set the system to boot over the network, enter the following command:

```
>>> SET BOOT EZA0
```

## 2.5 Setting the Default Recovery Action

There are five default recovery actions. You can change the default recovery action by entering the SET HALT command and the value or keyword associated with the action you want to set. Table 2–2 shows the five default recovery actions and their associated values. When the system is shipped, the default recovery action is set to halt.

**Table 2–2 Default Recovery Actions and Associated Values**

Recovery Action Keyword	Associated Value	Result
DEFAULT	0	The system halts and displays the console prompt. (Same as HALT.)
RESTART	1	The system tries to restart the operating system. If it fails to restart the operating system, it halts.
REBOOT	2	The system tries to boot. If it fails to boot, it halts.
HALT	3	The system halts and displays the console prompt.
restart_reboot	4	The system tries to restart the operating system. If it fails to restart the operating system, it tries to boot. If it fails to boot, it halts.

To set an alternative default recovery action, enter the SET HALT command using the value or keyword associated with the recovery action you want to set. For example, to set the system to halt, enter one of the following commands:

```
>>> SET HALT 3
>>> SET HALT HALT
```



# 3

---

## Console Commands

This chapter describes the console commands that a privileged user can enter when the system is in console mode. The system displays the console prompt (>>>) when it is in console mode. If the system is running the operating system software, see Section 2.1 for information on returning the system to console mode.

If the console security feature is enabled and a security password is set, you must log in to privileged console mode before using most of these commands. See Section 2.3 for information on the console security feature.

The following sections describe all the console commands, give the command format, and describe the significance of each parameter.

### 3.1 BOOT

The BOOT command initializes the processor and transfers execution to VMB. VMB attempts to boot the operating system from the specified device or list of devices, or from the default boot device if none is specified. The console qualifies the bootstrap operation by passing a boot flag's bitmap to VMB in R5.

*Format:*

**BOOT [qualifier-list] [{boot\_device},{boot\_device},...]**

If you do not enter either the qualifier or the device name, the default value is used. Explicitly stating the boot flag or the boot device overrides, but does not permanently change, the corresponding default value.

When specifying a list of boot devices (up to 32 characters, with devices separated by commas and no spaces), the system checks the devices in the order specified and boots from the first one that contains bootable software.

---

**Note**

---

If included in a string of boot devices, the Ethernet device, EZA0, should be placed only as the last device of the string. The system will continuously attempt to boot from EZA0.

---

Set the default boot device and boot flags with the SET BOOT and SET BFLAG commands. If you do not set a default boot device, the processor times out after 30 seconds and attempts to boot from the Ethernet device, EZA0.

*Qualifiers:*

*Command specific:*

/R5:{boot_flags}	A 32-bit hex value passed to VMB in R5. The console does not interpret this value. Use the SET BFLAG command to specify a default boot flag's longword. Use the SHOW BFLAG command to display the longword.
{boot_flags}	Same as /R5:{boot_flags}
[device_name]	A character string of up to 32 characters. When specifying a list of boot devices, the device names should be separated by commas and no spaces. Apart from checking the length, the console does not interpret or validate the device name. The console converts the string to uppercase, then passes VMB a string descriptor to this device name in R0. Use the SET BOOT command to specify a default boot device or list of devices. Use the SHOW BOOT command to display the default boot device. The factory default device is the Ethernet device, EZA0. Table 2-1 lists the boot devices supported by the Model 105A/106A systems.

*Examples:*

```
>>>SHOW BOOT
DKA300
>>>SHOW BFLAG
00000000
>>>B !Boot using default boot flags and device.
(BOOT/R5:0 DKA300)

2..
-DKA300
```

## 3.2 CONTINUE

The CONTINUE command causes the processor to begin instruction execution at the address currently contained in the program counter (PC). This address is the address stored in the PC when the system entered console mode or an address that the user specifies using the DEPOSIT command. The CONTINUE command does not perform a processor initialization. The console enters program I/O mode.

*Format:*

**CONTINUE**

*Example:*

```
>>>CONTINUE
$      !VMS DCL prompt
```

## 3.3 DEPOSIT

The DEPOSIT command deposits data into the address specified. If you do not specify an address space or data size qualifier, the console uses the last address space and data size used in a DEPOSIT, EXAMINE, MOVE, or SEARCH command. After processor initialization, the default address space is physical memory and the default data size is longword. If you specify conflicting address space or data sizes, the console ignores the command and issues an error message.

*Format:*

**DEPOSIT [qualifier-list] {address} {data} [data...]**

*Qualifiers:*

*Data control:* /B, /W, /L, /Q, /N:{count}, /STEP:{size}, /WRONG

*Address space control:* /G, /I, /M, /P, /V, /U

*Arguments:*

- {address} A longword address that specifies the first location into which data is deposited. The address can be an actual address or a symbolic address.
- {data} The data to be deposited. If the specified data is larger than the deposit data size, the firmware ignores the command and issues an error response. If the specified data is smaller than the deposit data size, it is extended on the left with zeros.

[[data]] Additional data to be deposited (as many as can fit on the command line).

*Examples:*

```
>>>D/P/B/N:1FF 0 0          ! Clear first 512 bytes of
                             ! physical memory.

>>>D/V/L/N:3 1234 5        ! Deposit 5 into four longwords
                             ! starting at virtual memory address
                             ! 1234.

>>>D/N:8 R0 FFFFFFFF       ! Loads GPRs R0 through R8 with -1.

>>>D/L/P/N:10/ST:200 0 8   ! Deposit 8 in the first longword of
                             ! the first 17 pages in physical
                             ! memory.

>>>D/N:200 - 0             ! Starting at previous address, clear
                             ! 513 longwords or 2052 bytes.
```

## 3.4 EXAMINE

The EXAMINE command examines the contents of the memory location or register specified by the address. If no address is specified, + is assumed. The display line consists of a single character address specifier, the physical address to be examined, and the examined data.

EXAMINE uses the same qualifiers as DEPOSIT. However, the /WRONG qualifier causes EXAMINE to ignore ECC errors on reads from physical memory. The EXAMINE command also supports an /INSTRUCTION qualifier, which will disassemble the instructions at the current address.

*Format:*

**EXAMINE [qualifier-list] [address]**

*Qualifiers:*

*Data control:* /B, /W, /L, /Q, /N:{count}, /STEP:{size}, /WRONG

*Address space control:* /G, /I, /M, /P, /V, /U

*Command specific:*

/INSTRUCTION Disassembles and displays the VAX MACRO-32 instruction at the specified address.

*Arguments:*

[[address]] A longword address that specifies the first location to be examined. The address can be an actual or a symbolic address. If no address is specified, + is assumed.

*Examples:*

```
>>>EX PC                ! Examine the PC.
    G 0000000F FFFFFFFC
>>>EX SP                ! Examine the SP.
    G 0000000E 00000200
>>>EX PSL               ! Examine the PSL.
    M 00000000 041F0000
>>>E/M                 ! Examine PSL another way.
    M 00000000 041F0000
>>>E R4/N:5            ! Examine R4 through R9.
    G 00000004 00000000
    G 00000005 00000000
    G 00000006 00000000
    G 00000007 00000000
    G 00000008 00000000
    G 00000009 801D9000

>>>EX PR$_SCBB        !Examine the SCBB, IPR 17
    I 00000011 2004A000 ! (decimal).

>>>E/P 0              ! Examine local memory 0.
    P 00000000 00000000

>>>EX /INS 20040000    ! Examine 1st byte of ROM.
    P 20040000  11 BRB  20040019

>>>EX /INS/N:5 20040019 ! Disassemble from branch.
    P 20040019  D0 MOVL  I^#20140000,@#20140000
    P 20040024  D2 MCOML @#20140030,@#20140502
    P 2004002F  D2 MCOML S^#0E,@#20140030
    P 20040036  7D MOVQ  R0,@#201404B2
    P 2004003D  D0 MOVL  I^#201404B2,R1
    P 20040044  DB MFPR  S^#2A,B^44(R1)

>>>E/INS              ! Look at next instruction.
    P 20040048  DB MFPR  S^#2B,B^48(R1)

>>>
```

## 3.5 FIND

The FIND command searches main memory, starting at address zero for a page-aligned 128-KByte segment of good memory, or a restart parameter block (RPB). If the command finds the segment or RPB, its address plus 512 is left in SP (R14). If it does not find the segment or RPB, the console issues an error message and preserves the contents of SP. If you do not specify a qualifier, /RPB is assumed.

*Format:*

**FIND [qualifier-list]**

*Qualifiers:*

*Command specific:*

/MEMORY Searches memory for a page-aligned block of good memory, 128 KBytes in length. The search looks only at memory that is deemed usable by the bitmap. This command leaves the contents of memory unchanged.

/RPB Searches all physical memory for an RPB. The search does not use the bitmap to qualify which pages are looked at. The command leaves the contents of memory unchanged.

*Examples:*

```
>>>EX SP                ! Check the SP.
   G 0000000E 00000000
>>>FIND /MEM            ! Look for a valid 128 KBytes.
>>>EX SP                ! Note where it was found.
   G 0000000E 00000200
>>>FIND /RPB           ! Check for valid RPB.
?2C FND ERR 00C00004    ! None to be found here.
>>>
```

## 3.6 HALT

The HALT command has no effect. It is included for compatibility with other VAX consoles.

*Format:*

**HALT**

*Example:*

```
>>>HALT                ! Pretend to halt.
>>>
```

## 3.7 HELP

The HELP command provides information about command syntax and usage.

*Format:*

### HELP

*Example:*

>>>HELP

Following is a brief summary of all the commands supported by the console:

UPPERCASE denotes a keyword that you must type in  
| denotes an OR condition  
[] denotes optional parameters  
<> denotes a field specifying a syntactically correct value  
.. denotes one of an inclusive range of integers  
... denotes that the previous item may be repeated

Valid qualifiers:

/B /W /L /Q /INSTRUCTION  
/G /I /V /P /M  
/STEP: /N: /NOT  
/WRONG /U

Valid commands:

BOOT [[/R5:]<boot\_flags>] [<boot\_device>]  
CONFIGURE  
CONTINUE  
DEPOSIT [<qualifiers>] <address> <datum> [<datum>...]  
EXAMINE [<qualifiers>] [<address>]  
FIND [/MEMORY | /RPB]  
HALT  
HELP  
INITIALIZE  
LOGIN  
MOVE [<qualifiers>] <address> <address>  
NEXT [<count>]  
REPEAT <command>  
SEARCH [<qualifiers>] <address> <pattern> [<mask>]  
SET BFLG <boot\_flags>  
SET BOOT <boot\_device>  
  
SET HALT <0..4 |DEFAULT|RESTART|REBOOT|HALT|RESTART\_REBOOT>  
SET HOST/DUP/DSSI/BUS:<0..1> <node\_number> [<task>]  
SET HOST/DUP/UQSSP </DISK|/TAPE> <controller\_number>[<task>]  
SET HOST/DUP/UQSSP <physical\_CSR\_address> [<task>]  
SET HOST/MAINTENANCE/UQSSP/SERVICE <controller\_number>  
SET HOST/MAINTENANCE/UQSSP <physical\_CSR\_address>  
SET LANGUAGE <1..15>

```
SET PSE <0..1 | DISABLED | ENABLED>
SET PSWD <password>
SET RECALL <0..1 | DISABLED | ENABLED>
SET SCSI <0..7>
SET SCSI_ID

SHOW BFLG
SHOW BOOT
SHOW CONFIG

SHOW DEVICE
SHOW DSSI
SHOW ETHERNET
SHOW HALT
SHOW LANGUAGE
SHOW MEMORY [/FULL]

SHOW PSE
SHOW QBUS
SHOW RECALL
SHOW RLV12
SHOW SCSI
SHOW SCSI_ID
SHOW TRANSLATION <physical_address>
SHOW UQSSP
SHOW VERSION
START <address>
TEST [<test_code> [<parameters>]]
UNJAM
X <address> <count>

>>>
```

## 3.8 INITIALIZE

The INITIALIZE command performs a processor initialization.

*Format:*

### INITIALIZE

The following registers are initialized:

Register	State at Initialization
PSL	041F0000
IPL	1F
ASTLVL	4
SISR	0
ICCS	Bits <6> and <0> clear; the rest are unpredictable
RXCS	0
TXCS	80
MAPEN	0
Caches	Flushed
Instruction buffer	Unaffected
Console previous reference	Longword, physical, address 0
TODR	Unaffected
Main memory	Unaffected
General registers	Unaffected
Halt code	Unaffected
Bootstrap-in-progress flag	Unaffected
Internal restart-in-progress flag	Unaffected

The firmware clears all error status bits and initializes the following:

- CDAL bus timer
- Address decode and match registers
- Programmable timer interrupt vectors
- The QUART LPR register is set to 9600 baud
- All error status bits are cleared

*Example:*

```
>>>INIT  
>>>
```

## 3.9 LOGIN

Allows you to put the system in privileged console mode. When the console security feature is enabled and when you put the system in console mode, the system operates in unprivileged console mode. You can access only a subset of the console commands. To access the full range of console commands, you must use this command. This command may only be executed in secure console mode. The format of this command is as follows:

### **LO[GIN]**

When you enter the command, the system prompts you for a password as follows:

Password:

You must enter the current console security password. If you do not enter the correct password, the system displays the error message, **INCORRECT PASSWORD**. When you enter the console security password, the system operates in privileged console mode. In this mode, you can use all the console commands. The system exits from privileged console mode when you enter one of the following console commands:

- **BOOT**
- **CONTINUE**
- **HALT**
- **START**

## 3.10 MOVE

The MOVE command copies the block of memory starting at the source address to a block beginning at the destination address. Typically, this command has an /N qualifier so that more than one datum is transferred. The destination correctly reflects the contents of the source, regardless of the overlap between the source and the data.

The MOVE command actually performs byte, word, longword, and quadword reads and writes as needed in the process of moving the data. Moves are supported only for the physical and virtual address spaces.

*Format:*

**MOVE [qualifier-list] {src\_address} {dest\_address}**

*Qualifiers:*

*Data control:* /B, /W, /L, /Q, /N:{count}, /STEP:{size}, /WRONG

*Address space control:* /V, /U, /P

*Arguments:*

{src\_address}      A longword address that specifies the first location of the source data to be copied.

{dest\_address}    A longword address that specifies the destination of the first byte of data. These addresses may be an actual address or a symbolic address. If no address is specified, + is assumed.

*Examples:*

```
>>>EX/N:4 0                   ! Observe destination.
P 00000000 00000000
P 00000004 00000000
P 00000008 00000000
P 0000000C 00000000
P 00000010 00000000

>>>EX/N:4 200                 ! Observe source data.
P 00000200 58DD0520
P 00000204 585E04C1
P 00000208 00FF8FB8
P 0000020C 5208A8D0
P 00000210 540CA8DE

>>>MOV/N:4 200 0              ! Move the data.
```

```
>>>EX/N:4 0          ! Observe moved data.
P 00000000 58DD0520
P 00000004 585E04C1
P 00000008 00FF8FBB
P 0000000C 5208A8D0
P 00000010 540CA8DE
>>>
```

### 3.11 NEXT

The NEXT command executes the specified number of macro instructions. If no count is specified, 1 is assumed.

After the last macro instruction is executed, the console reenters console I/O mode.

*Format:*

**NEXT {count}**

The console implements the NEXT command, using the trace trap enable and trace pending bits in the PSL and the trace pending vector in the SCB.

The console enters the “Spacebar Step Mode”. In this mode, subsequent spacebar strokes initiate single steps and a carriage return forces a return to the console prompt.

The following restrictions apply:

- If memory management is enabled, the NEXT command works only if the first page in SSC RAM is mapped in S0 (system) space.
- Overhead associated with the NEXT command affects execution time of an instruction.
- The NEXT command elevates the IPL to 31 for long periods of time (milliseconds) while single-stepping over several commands.
- Unpredictable results occur if the macro instruction being stepped over modifies either the SCBB or the trace trap entry. This means that you cannot use the NEXT command in conjunction with other debuggers.

### Arguments:

{count}      A value representing the number of macro instructions to execute.

### Examples:

```
>>>DEP 1000 50D650D4                   ! Create a simple program.
>>>DEP 1004 125005D1
>>>DEP 1008 00FE11F9
>>>EX /INSTRUCTION /N:5 1000         ! List it.
P 00001000   D4 CLRL    R0
P 00001002   D6 INCL    R0
P 00001004   D1 CMPL    S^#05,R0
P 00001007   12 BNEQ    00001002
P 00001009   11 BRB     00001009
P 0000100B   00 HALT
>>>DEP PR$ SCBB 200                   ! Set up a user SCBB...
>>>DEP PC 1000                         ! ...and the PC.
>>>
>>>N                                   ! Single step...
P 00001002   D6 INCL    R0            ! SPACEBAR
P 00001004   D1 CMPL    S^#05,R0     ! SPACEBAR
P 00001007   12 BNEQ    00001002     ! SPACEBAR
P 00001002   D6 INCL    R0            ! CR
>>>N 5                                 ! ...or multiple step the program.
P 00001004   D1 CMPL    S^#05,R0
P 00001007   12 BNEQ    00001002
P 00001002   D6 INCL    R0
P 00001004   D1 CMPL    S^#05,R0
P 00001007   12 BNEQ    00001002
>>>N 7
P 00001002   D6 INCL    R0
P 00001004   D1 CMPL    S^#05,R0
P 00001007   12 BNEQ    00001002
P 00001002   D6 INCL    R0
P 00001004   D1 CMPL    S^#05,R0
P 00001007   12 BNEQ    00001002
P 00001009   11 BRB     00001009
>>>N
P 00001009   11 BRB     00001009
>>>
```

## 3.12 REPEAT

The REPEAT command repeatedly displays and executes the specified command. Press `CTRL/C` to stop the command. You can specify any valid console command except the REPEAT command.

*Format:*

**REPEAT {command}**

*Arguments:*

{command} A valid console command other than REPEAT.

*Examples:*

```
>>>REPEAT EX PR$ TODR !Watch the clock.
I 0000001B 5AFE78CE
I 0000001B 5AFE78D1
I 0000001B 5AFE78FD
I 0000001B 5AFE7900
I 0000001B 5AFE7903
I 0000001B 5AFE7907
I 0000001B 5AFE790A
I 0000001B 5AFE790D
I 0000001B 5AFE7910
I 0000001B 5AFE793C
I 0000001B 5AFE793F
I 0000001B 5AFE7942
I 0000001B 5AFE7946
I 0000001B 5AFE7949
I 0000001B 5AFE794C
I 0000001B 5AFE794F
I 0000001B 5^C
>>>
```

### 3.13 SEARCH

The SEARCH command finds all occurrences of a pattern and reports the addresses where the pattern was found. If the /NOT qualifier is present, the command reports all addresses in which the pattern did not match.

*Format:*

**SEARCH [qualifier-list] {address} {pattern} [{mask}]**

SEARCH accepts an optional mask that indicates bits to be ignored (*don't care* bits). For example, to ignore bit 0 in the comparison, specify a mask of 1. The mask, if not present, defaults to 0.

A match occurs if (pattern and not mask) = (data and not mask), where:

Pattern is the target data

Mask is the optional don't care bitmask (which defaults to 0)

Data is the data at the current address

SEARCH reports the address under the following conditions:

<b>/NOT Qualifier</b>	<b>Match Condition</b>	<b>Action</b>
Absent	True	Report address
Absent	False	No report
Present	True	No report
Present	False	Report address

The address is advanced by the size of the pattern (byte, word, longword, or quadword), unless overridden by the /STEP qualifier.

*Qualifiers:*

*Data control:* /B, /W, /L, /Q, /N:{count}, /STEP:{size}, /WRONG

*Address space control:* /P, /V, /U

*Command specific:*

/NOT           Inverts the sense of the match.

### Arguments:

{start\_  
address} A longword address that specifies the first location subject to the search. This address can be an actual address or a symbolic address. If no address is specified, + is assumed.

{pattern} The target data.

[{mask}] A mask of the bits desired in the comparison.

### Examples:

```
>>>DEP /P/L/N:1000 0 0          ! Clear some memory.
>>>
>>>DEP 300 12345678             ! Deposit some search data.
>>>DEP 401 12345678
>>>DEP 502 87654321
>>>
>>>SEARCH /N:1000 /ST:1 0 12345678 ! Search for all occurrences
P 00000300 12345678             ! of 12345678 on any byte
P 00000401 12345678             ! boundary. Then try on
>>>SEARCH /N:1000 0 12345678      ! longword boundaries.
P 00000300 12345678             ! Search for all non-zero
>>>SEARCH /N:1000 /NOT 0 0        ! longwords.
P 00000300 12345678
P 00000400 34567800
P 00000404 00000012
P 00000500 43210000
P 00000504 00008765
>>>SEARCH /N:1000 /ST:1 0 1 FFFFFFFE ! Search for odd-numbered
! longwords on any boundary.
P 00000502 87654321
P 00000503 00876543
P 00000504 00008765
P 00000505 00000087
>>>SEARCH /N:1000 /B 0 12        ! Search for all occurrences
P 00000303 12                   ! of the byte 12.
P 00000404 12
>>>SEARCH /N:1000 /ST:1 /w 0 FE11 ! Search for all words that
>>>                               ! could be interpreted as
>>>                               ! a spin (10$: brb 10$).
>>>                               ! Note that none were found.
```

## 3.14 SET

The SET command sets the parameter to the value you specify.

*Format:*

**SET {parameter} {value}**

*Parameters:*

BFLAG	Sets the default R5 boot flags. The value must be a hex number of up to eight digits.
BOOT	Sets the default boot device. The value must be a valid device name or list of device names as specified in the BOOT command description in Section 3.1.
DSSI_ID	Sets the bus number to 0 or 1, and the DSSI ID to a number in the range from 0 to 7.
HALT	Sets the user-defined halt action. Acceptable values are the keywords "default", "restart", "reboot", "halt", "restart_reboot", or a number in the range 0 to 4 inclusive.
HOST	Makes a DUP connection to a DSSI device.
LANGUAGE	Sets console language and keyboard type. If the current console terminal does not support the multinational character set (MCS), then this command has no effect and the console message appears in English. Values are 1 through 15.
PSWD	Allows you to enable or disable the console security feature or password of the system. The SET PSE command accepts the following values:  0—Console security disabled 1—Console security enabled  When the console security feature is enabled, only a subset of the console commands are available to the user. These commands are listed in Section 2.3. To enable the complete set of console commands once the console security feature is enabled, you must use the LOGIN command (see Section 3.9).
RECALL	Sets command recall state to either ENABLED (1) or DISABLED (0).
SCSI_ID	Sets the SCSI ID of the SCSI controller, to a number in the range 0 to 7. The SCSI ID of the SCSI controller is set to 6 by default.

*Qualifiers:* Listed in the parameter descriptions above.

*Examples:*

```
>>>
>>>SET BFLAG 220
>>>
>>>SET BOOT DUA0
>>>
>>>SET LANGUAGE 5
>>>
>>>SET HALT RESTART
>>>
```

### 3.15 SHOW

The SHOW command displays the console parameter you specify.

*Format:*

**SHOW {parameter}**

*Parameters:*

BFLAG	Displays the default R5 boot flags.
BOOT	Displays the default boot device.
CONFIG	Displays the system configuration. The command displays information about the devices that the firmware has tested. It also displays the device errors that the most recent device test detected.
DEVICE	Displays all devices in the system.
HALT	Shows the user-defined halt action.
DSSI	Shows the status of all nodes that are on the DSSI bus. For each node on the DSSI bus, the console displays the node number, the node name, and the boot name and type of the device, if available. The command does not indicate the "bootability" of the device.  The node that issues the command reports a node name of "*".  The device information is obtained from the media type field of the MSCP command GET UNIT STATUS. In the case where the node is not running or is not capable of running an MSCP server, then no device information is displayed.
DSSI_ID	Shows the values of the DSSI ID(s)

ETHERNET	Displays hardware Ethernet address for all Ethernet adapters that can be found. Displays as blank if no Ethernet adapter is present.
LANGUAGE	Displays console language and keyboard type. Refer to the corresponding SET LANGUAGE command for the meaning.
MEMORY	Displays main memory configuration.
MEMORY/FULL	Additionally, displays the normally inaccessible areas of memory, such as the PFN bitmap pages, the console scratch memory pages, the Q22-bus scatter-gather map pages. Also reports the addresses of bad pages, as defined by the bitmap.
PSE	Displays the condition of the console security feature of the system.
QBUS	<p>Displays all Q22-bus I/O addresses that respond to an aligned word read, and speculative device name information. For each address, the console displays the address in the VAX I/O space in hex, the address as it would appear in the Q22-bus I/O space in octal, and the word data that was read in hex.</p> <p>This command may take several minutes to complete. Press <b>CTRL/C</b> to terminate the command. During execution, the command disables the scatter-gather map.</p>
SAVED_STATE	<p>Shows the saved values of the following SET commands:</p> <ul style="list-style-type: none"> <li>BFLAG</li> <li>BOOT</li> <li>DSSI_ID</li> <li>HALT</li> <li>LANGUAGE</li> <li>SCSI_ID</li> </ul>
SCSI_ID	Shows the value of the CPU SCSI ID.
RECALL	Shows the current state of command recall, either ENABLED or DISABLED.
RLV12	Displays all RL01 and RL02 disks that appear on the Q22-bus.
UQSSP	<p>Displays the status of all disks and tapes that can be found on the Q22-bus that support the UQSSP protocol. For each such disk or tape on the Q22-bus, the firmware displays the controller number, the controller CSR address, and the boot name and type of each device connected to the controller. The command does not indicate whether the device contains a bootable image.</p> <p>This information is obtained from the media type field of the MSCP command GET UNIT STATUS. The console does not display device information if a node is not running (or cannot run) an MSCP server.</p>

SCSI Shows any SCSI devices in the system.

TRANSLATION Shows any virtual addresses that map to the specified physical address. The firmware uses the current values of page table base and length registers to perform its search; it is assumed that page tables have been properly built.

VERSION Displays the current firmware version.

*Qualifiers:* Listed in the parameter descriptions above.

*Examples:*

```
>>>
>>>SHOW BFLAG
00000220
>>>
>>>SHOW BOOT
DUA0
>>>SHOW CONTROLP
>>>
>>>SHOW ETHERNET
Ethernet Adapter
-EZA0 (08-00-2B-0B-29-14)
>>>
>>>SHOW HALT
restart
>>>
>>>SHOW LANGUAGE
English (United States/Canada)
>>>

>>>SHOW MEMORY

16 MB RAM, SIMM Set (0A,0B,0C,0D) present
Memory Set 0: 04000000 to 04FFFFFF, 16MB, 32768 good pages, 0 bad pages

64 MB RAM, SIMM Set (1E,1F,1G,1H) present
Memory Set 1: 00000000 to 03FFFFFF, 64MB, 131072 good pages, 0 bad pages

Total of 80MB, 163840 good pages, 0 bad pages, 136 reserved pages
>>>

>>>SHOW MEM/FULL

16 MB RAM, SIMM Set (0A,0B,0C,0D) present
Memory Set 0: 00000000 to 00FFFFFF, 16MB, 32768 good pages, 0 bad pages

Total of 16MB, 32768 good pages, 0 bad pages, 104 reserved pages

Memory Bitmap
-00FF3000 to 00FF3FFF, 8 pages

Console Scratch Area
-00FF4000 to 00FF7FFF, 32 pages
```

```
Scan of Bad Pages
>>>

>>>SHOW SCSI
SCSI Adapter 0 (761300), SCSI ID 7
-DKA100 (DEC TLZ04)
>>>
>>>SHOW TRANSLATION 1000
V 80001000
>>>
>>>SHOW VERSION
KA53 Vn.n VMBn.n
>>>

>>>SHOW DSSI
DSSI Bus 0 Node 1 (R5WBAA)
-DIA1 (RF35)

DSSI Bus 0 Node 7 (*)
```

## 3.16 START

The **START** command starts instruction execution at the address you specify. If no address is given, the current PC is used. If memory mapping is enabled, macro instructions are executed from virtual memory, and the address is treated as a virtual address. The **START** command is equivalent to a **DEPOSIT** to PC, followed by a **CONTINUE**. It does not perform a processor initialization.

*Format:*

**START** [{address}]

*Arguments:*

[address]      The address at which to begin execution. This address is loaded into the user's PC.

*Example:*

```
>>>START 1000
```

## 3.17 TEST

The TEST command invokes a diagnostic test program specified by the test number. If you enter a test number of 0 (zero), the powerup diagnostics are executed. The console accepts an optional list of up to five additional hexadecimal arguments.

*Format:*

**TEST** [{test\_number} [{test\_arguments}]]

*Arguments:*

{test_number}	A two-digit hex number specifying the test to be executed.
{test_arguments}	Up to five additional test arguments. These arguments are accepted, but they have no meaning to the console.

*Example:*

```
>>>TEST 0
KA53-A Vn.n, VMB 2.14
Performing normal system tests.
74..73..72..71..70..69..68..67..66..65..64..63..62..61..60..59..
58..57..56..55..54..53..52..51..50..49..48..47..46..45..44..43..
42..41..40..39..38..37..36..35..34..33..32..31..30..29..28..27..
26..25..24..23..22..21..20..19..18..17..16..15..14..13..12..11..
10..09..08..07..06..05..04..03..
Tests completed.
>>>
```

*Example:*

```
>>>
>>>          ! Display the CPU registers.
>>>
>>>T 9C

savpc=20048C68 savpsl=20048C68   sbr=03FA0000   slr=00003040
p0br=80000000  p0lr=00182000   plbr=00000000   pllr=00000000
sid=13001401   sie=03020801   mapen=00000000
tcr0=00000000  tir0=00000000   tnir0=00000000  tivr0=00000078
tcr1=00000001  tirl=02AF768E   tnir1=0000000F  tivrl=0000007C
bdr=3FFB08FF  sscrr=00D05070   scbb=20053400
DZ  csr=0020    tcr=0008        msr=0F75
scr=0000D000  dser=00000000   qbear=0000000F  dear=00000000
qbr=03FF8000  ipcr=0000
nicsr0=1FFF0003  3=00004030   4=00004050   5=8039FF00   6=83E0F000   7=00000000
nicsr9=04E204E2  10=00040000  11=00000000  12=00000000  13=00000000  15=0000FFFF
NISA=08-00-2B-29-1C-7A  intmsk=00  intreq=00  scdadr=00000000  scddir=0
SCSI_CSRS 0=00 1=00 2=00 3=00 4=00 6=05 5=05 7=00 8=16 9=5B A=5B B=00 C=04
VIC.....icsr=00000001  vmar=000007E0   ecr=000000CA
PC.....pcctl=FFFFFFC13  pcsts=FFFFFF800  pcadr=FFFFFFF8
BC_128K..cctl=00000007  bcetsts=000003E0  bcetidx=FFFFFFE0  bcetag=FFFFFFE0
.....bcedsts=00000F00  bcedidx=001FFF8  bcedecc=00000000
.....nests=00000000  neoadr=E0055F70  neocmd=8000FF04  neicmd=000003FF
.....nedathi=FFFFFFF  nedatlo=FF7F9FFF  cefsts=00019200  cefadr=E00002C0
MEMORY...mesr=00006000  mear=08406010  Add=21018040  mmcdsr=01111000
.....memcon0=80000005  memcon1=00000007  moamr=00000000  sssr=C0CE
NCA.....cesr=00000000  cmcdsr=0000C108  cnear=00000000
.....csear1=00000000  csear2=00000000  cioear1=00000000  cioear2=000002C0
.....iccs=00000000  nicr=FFFFD8F0  icr=FFFFD8F0  todr=00000000
>>>
```

*Example:*

```
>>>
>>> ; list diagnostics and scripts
>>>T 9E
Test
# Address Name Parameters
-----
20053800 SCB
20054590 De_executive
30 200637BC Memory_Init_Bitmap *** mark_Hard_SBEs *****
31 20064094 Memory_Setup_CSRS *****
32 20064464 NMC_registers *****
33 20064600 NMC_powerup **
34 2005D0A4 SSC_ROM ***
35 20067394 B_Cache_diag_mode bypass_test_mask *****
37 200681C4 Cache_w_Memory bypass_test_mask *****
40 2006242C Memory_count_pages SIMM_set0 SIMM_set1 Soft_errs_allowed *****
41 200579C0 Board_Reset *
42 2005B56C Chk_for_Interrupts *****
46 200670D4 P_Cache_diag_mode bypass_test_mask *****
47 20063D7C Memory_Refresh start_a end incr cont_on_err time_seconds *****
48 20061558 Memory_Addr_shorts start_add end_add * cont_on_err pat2 pat3 ****
4A 200634E0 Memory_ECC_SBEs start_add end_add add_incr cont_on_err *****
4B 20061D78 Memory_Byte_Errors start_add end_add add_incr cont_on_err *****
4C 20062E90 Memory_ECC_Logic start_add end_add add_incr cont_on_err *****
4D 200613BC Memory_Address start_add end_add add_incr cont_on_err *****
4E 20061AF8 Memory_Byte start_add end_add add_incr cont_on_err *****
4F 20062628 Memory_Data start_add end_add add_incr cont_on_err *****
51 2005BA5C FPA *****
52 2005BED8 SSC_Prog_timers which_timer wait_time_us ***
53 2005C1A8 SSC_TOY_Clock repeat_test_250ms_ea Tolerance ***
54 2005B670 Virtual_Mode *****
55 2005C360 Interval_Timer *****
58 200602F0 SHAC_RESET port_number time_secs not_pres
59 2005F584 SGEC_LPBACK_ASSIST time_secs **
5C 2005FAEC SHAC bypass_test_mask *****
5F 2005E870 SGEC loopback_type no_ram_tests *****
63 2005CF48 QDSS_any input_csr selftest_r0 selftest_r1 *****
80 200649FC CQBIC_memory bypass_test_mask *****
81 2005CBA8 Qbus_MSCP IP_csr *****
82 2005CD70 Qbus_DELQA device_num_addr ****
83 20058C70 QZA_Intlpbck1 controller_number *****
84 2005A328 QZA_Intlpbck2 controller_number *****
85 20057EE4 QZA_memory incr test_pattern controller_number *****
86 200583A0 QZA_DMA Controller_number main_mem_buf *****
90 2005BE54 CQBIC_registers *
91 2005BDE8 CQBIC_powerup **
99 200647D0 Flush_Ena_Caches dis_flush_VIC dis_flush_BC dis_flush_PC
```

```

9A 2005D1DC INTERACTION      pass_count disable_device ****
9B 20064680 Init_memory          ***
9C 2005D1A8 List_CPU_registers      *
9D 2005DEC4 Utility            Modify_CPU_type *****
9E 2005C518 List_diagnostics     script_number *
9F 20060888 Create_A0_Script        *****
C1 20057B90 SSC_RAM_Data          *
C2 20057D68 SSC_RAM_Data_Addr  *
C5 2005E770 SSC_registers        *
C6 20057AD4 SSC_powerup          *****
D0 20066C98 V_Cache_diag_mode     bypass_test_mask *****
D2 20065220 O_Bit_diag_mode       bypass_test_mask *****
DA 20067FE8 PB_Flush_Cache        *****
DB 20065A18 Speed              print_speed *****
DC 200642BC NO_Memory_present   *
DD 200661FC B_Cache_Data_debug     start_add end_add add_incr *****
DE 20065DB4 B_Cache_Tag_Debug     start_add end_add add_incr *****
DF 20065614 O_BIT_DEBUG           start_add end_add add_incr seg_incr *****
E0 20068498 SCSI              environment reset_bus time_s *****
E1 20068578 SCSI_Utility      environment util_nbr target_ID lun *****
E2 20068630 SCSI_MAP         bypass_test addr_incr_data_tst *****
E4 200689D4 DZ              environment *****
E8 20068B4C SYNC            environment *****
E9 20068BF4 SYNC_Utility     environment *****
EC 20068CAC ASYNC          environment *****

```

Scripts

```

# Description
A0 User defined scripts
A1 Powerup tests, Functional Verify, continue on error, numeric countdown
A3 Functional Verify, stop on error, test # announcements
A4 Loop on A3 Functional Verify
A6 Memory tests, mark only multiple bit errors
A7 Memory tests
A8 Memory acceptance tests, mark single and multi-bit errors, call A7
A9 Memory tests, stop on error
B2 Extended tests plus BF
B5 Extended tests, then loop
BF DZ, SYNC, ASYNC with loopbacks
>>>
>>>

```

### 3.18 UNJAM

The UNJAM command performs an I/O bus reset, by writing a 1 (one) to IPR 55 (decimal). SHAC and SGEC are explicitly reset, EDAL\_INTREQ register error bits are cleared and SCST\_DMA map registers are cleared.

*Format:*

**UNJAM**

*Example:*

```
>>>UNJAM  
>>>
```

### 3.19 X—Binary Load and Unload

The X command is for use by automatic systems communicating with the console.

The X command loads or unloads (that is, writes to memory, or reads from memory) the specified number of data bytes through the console serial line (regardless of console type) starting at the specified address.

*Format:*

**X {address} {count} CR {line\_checksum} {data} {data\_checksum}**

If bit 31 of the count is clear, data is received by the console and deposited into memory. If bit 31 is set, data is read from memory and sent by the console. The remaining bits in the count are a positive number indicating the number of bytes to load or unload.

The console accepts the command upon receiving the carriage return. The next byte the console receives is the command checksum, which is not echoed. The command checksum is verified by adding all command characters, including the checksum and separating space (but not including the terminating carriage return, rubouts, or characters deleted by rubout), into an 8-bit register initially set to zero. If no errors occur, the result is zero. If the command checksum is correct, the console responds with the input prompt and either sends data to the requester or prepares to receive data. If the command checksum is in error, the console responds with an error message. The intent is to prevent inadvertent operator entry into a mode where the console is accepting characters from the keyboard as data, with no escape mechanism possible.

If the command is a load (bit 31 of the count is clear), the console responds with the input prompt (>>>), then accepts the specified number of bytes of data for depositing to memory, and an additional byte of received data checksum. The data is verified by adding all data characters and the checksum character into an 8-bit register initially set to zero. If the final content of the register is nonzero, the data or checksum are in error, and the console responds with an error message.

If the command is a binary unload (bit 31 of the count is set), the console responds with the input prompt (>>>), followed by the specified number of bytes of binary data. As each byte is sent, it is added to a checksum register initially set to zero. At the end of the transmission, the two's complement of the low byte of the register is sent.

If the data checksum is incorrect on a load, or if memory or line errors occur during the transmission of data, the entire transmission is completed, then the console issues an error message. If an error occurs during loading, the contents of the memory being loaded are unpredictable.

The console represses echo while it is receiving the data string and checksums.

The console terminates all flow control when it receives the carriage return at the end of the command line in order to avoid treating flow control characters from the terminal as valid command line checksums.

You can control the console serial line during a binary unload using control characters (CTRL/C, CTRL/S, CTRL/O, and so on). You cannot control the console serial line during a binary load, since all received characters are valid binary data.

The console has the following timing requirements:

- It must receive data being loaded with a binary load command at a rate of at least one byte every 60 seconds.
- It must receive the command checksum that precedes the data within 60 seconds of the carriage return that terminates the command line.
- It must receive the data checksum within 60 seconds of the last data byte.

If any of these timing requirements are not met, then the console aborts the transmission by issuing an error message and returning to the console prompt.

The entire command, including the checksum, can be sent to the console as a single burst of characters at the specified character rate of the console serial line. The console is able to receive at least 4 Kbytes of data in a single X command.

### 3.20 ! (Comment)

The comment character (an exclamation point) is used to document command sequences. It can appear anywhere on the command line. All characters following the comment character are ignored.

*Format:* !

*Example:*

```
>>>! The console ignores this line.  
>>>
```

# 4

---

## Hardware Specifications

This chapter lists the hardware specifications of the following devices:

- System unit
- Internal SCSI device
- KA53-AA/KA54-AA CPU
- Internal DSSI device

### 4.1 System Unit Specifications

The following tables list the specifications for the VAX 4000 Model 105A and Model 106A systems.

**Table 4–1 System Specifications: VAX 4000 Model 105A/106A**

<b>Subject</b>	<b>Description</b>
Processor	Model 105A = KA53 (NVAX), Model 106A = KA54 (NVAX).
Boot and diagnostic firmware ROM	512KB.
DRAM memory	Expandable from 16MB using one set of four 4MB SIMMs to a maximum of 128MB using two sets of four 16MB SIMMs. These are MS44L–BC and MS44–DC memory options.
Hard disk	RF35, RF36, and RF31T (the system supports a maximum of three disk devices in the enclosure).
Tape drive	TZ30, TZK10, TZK11, TLZ06, TLZ07.
Compact disc drive	RRD42, RRD43
Terminals	Supports the VT series.
Interfaces	One or two DSSI buses, one synchronous SCSI bus, one ThinWire Ethernet port <sup>1</sup> , one standard Ethernet port <sup>1</sup> (thickwire), three MMJ ports, one modem port. Optional: 8 or 16 additional asynchronous DEC423 MMJ ports or 8 additional asynchronous modem ports, 2 synchronous ports.
Input voltage	Automatically adjusting ac input. Range: 100 V ac to 120 V ac or 220 V ac to 240 V ac.
Maximum inrush current	2.0 amperes (A) at 220 V ac.
Maximum running current	2.2 A at 110 V ac, 1.1 A at 220 V ac.
Steady state current	2.2 A at 110 V ac, 1.1 A at 220 V ac.
Maximum power consumption	200 watts (W).
Frequency	49 Hz to 61 Hz.

<sup>1</sup>Both Ethernet types cannot be used simultaneously.

**Table 4–2 System Unit Metrics**

System Unit	Weight <sup>1</sup> kg (lb)	Height cm (in)	Width cm (in)	Depth cm (in)
Model 105A/106A	18.18 (40)	14.99 (5.90)	46.38 (18.26)	40.00 (15.75)

<sup>1</sup>Depends on configuration

**Table 4–3 System Storage Conditions**

Storage Condition	Range or Value
Temperature range	5°C to 50°C (41°F to 122°F )
Relative humidity	10% to 95% at 66°C (noncondensing)
Altitude	0 m to 2400 m (0 ft to 8000 ft)
Maximum wet bulb temperature	32°C (90°F)
Minimum dew point	2°C (36°F)

**Table 4–4 System Operating Conditions and Nonoperating Conditions**

Operating Conditions	Range or Value
Temperature range	10°C (50°F) to 32°C (90°F) with TZ30 tape drive; otherwise, 10°C (50°F) to 40°C (104°F)
Temperature change rate	11°C (20°F) per hour maximum
Relative humidity	10% to 90% noncondensing (20% to 80% if tape device installed)
Maximum wet bulb temperature	28°C (82°F)
Minimum dew point	2°C (36°F)
Altitude	2400 m (8000 ft) at 36°C (96°F)

(continued on next page)

**Table 4–4 (Cont.) System Operating Conditions and Nonoperating Conditions**

<b>Nonoperating Conditions</b>	<b>Range or Value</b>
Temperature range	–40°C (–40°F) to 66°C (151°F)
Relative humidity	10% to 95% at 66°C (151°F)
Altitude	4900 m (16 000 ft)
Maximum wet bulb temperature	28°C (82°F)
Minimum dew point	2°C (36°F)

## 4.2 Internal DSSI Device Specifications

The following tables list the specifications for the internal DSSI devices.

**Table 4–5 DSSI Hard Disk Drive Specifications**

<b>Formatted Storage Capacity</b>	<b>RF31T</b>	<b>RF35</b>	<b>RF36</b>
Per drive (MB )	381	852	1600
Blocks per track	57	57	54-108
Blocks per drive	744,534	1,664,628	3,125,408
Buffer size (Kbytes)	512	512	512

<b>Performance</b>	<b>RF31T</b>	<b>RF35</b>	<b>RF36</b>
Transfer rate to or from media (MB/second)	3.3	3.3	3.3
Data transfer rate (MB/second)	4.0	4.0	5.0
Average seek time (milliseconds)	5.5	9.5	9.7
Maximum seek time, full stroke (milliseconds)	–	19	19
Average latency (milliseconds)	5.6	5.6	5.6
Average access (milliseconds)	11.1	15.1	15.3

**Table 4–6 TZ30 Tape Drive Specifications**

<b>Subject</b>	<b>Description</b>
Mode of operation	Streaming
Media	12.77 mm (0.5 in) unformatted magnetic tape
Bit density	2624 bits/cm (6667 bits/in)
Number of tracks	22
Transfer rate (at host)	62.5Kb/s
Tape speed	190 cm/s (75 in/s)
Track format	Multiple track serpentine recording
Cartridge capacity	95MB, formatted (approx)

**Table 4–7 TZK10 QIC Tape Drive Specifications**

<b>Subject</b>	<b>Description</b>
Mode of operation	Streaming.
Media	DC6320, DC6525, or Digital approved equivalent. See the <i>VAX 4000 Model 105A/106A Operator Information</i> manual.
Track width: write	0.1778 mm +0.0000, -0.0127 mm (0.0070 in +0.0000, -0.0005 in).
Track width: read	0.1270 mm +0.0127, -0.0000 mm (0.0050 in +0.0005, -0.0000 in).
Bit density	16Kbyte/in.
Number of tracks	26.
Transfer rate	200Kbyte/s at average streaming mode, 1.5MB/s at SCSI maximum.
Tape speed	305 cm/s (120 in/s).
Track format	Multiple track serpentine recording.
Cartridge capacity	320MB or 525MB, formatted (approx), depending on the QIC tape used.

**Table 4–8 TZK11 QIC Tape Drive Specifications**

<b>Subject</b>	<b>Description</b>
Mode of operation	Streaming.
Media	DC9200, DC9200XL, or Digital approved equivalent. See the <i>VAX 4000 Model 105A/106A Operator Information</i> manual.
Track width: write	0.1778 mm $\pm$ 0.00038 mm (0.0070 in) $\pm$ 0.00015 in
Track width: read	0.0762 mm $\pm$ 0.00038 mm (0.0030 in) $\pm$ 0.00015 in
Bit density	40,640 bits/in.
Number of tracks	42.
Transfer rate	300K bytes/s at average streaming mode, 3 M bytes/s burst transfer rate.
Tape speed	70.9 inches/sec with QIC-2GB cartridge.
Track format	Multiple track serpentine recording.
Cartridge capacity	2 G or 2.5 Gbytes, formatted (approx), depending on the QIC tape used.

**Table 4–9 TLZ06 Cassette Tape Drive Specifications**

<b>Subject</b>	<b>Description</b>
Mode of operation	Streaming and start/stop.
Media	TLZ04-CA, TLZ06-CA, or Digital approved equivalent. See the <i>VAX 4000 Model 105A/106A Operator Information</i> manual.
Bit density	114Mb/in.
Transfer rate (sustained)	400KB/s noncompression
Recording format	Digital Data Storage (DDS, DC)

**Table 4–10 TLZ07 Cassette Tape Drive Specifications**

<b>Subject</b>	<b>Description</b>
Mode of operation	Streaming and start/stop.
Media	TLZ04-CA, TLZ06-CA, TLZ07-CA or Digital approved equivalent. See the <i>VAX 4000 Model 105A/106A Operator Information</i> manual.
Bit density	114Mb/in.
Transfer rate (sustained)	400KB/s noncompression
Recording format	Digital Data Storage (DDS, DC)

**Table 4–11 RRD42 Compact Disc Drive Specifications**

<b>Subject</b>	<b>Description</b>
Acceptable discs	CD-ROM mode-1 data discs CD-ROM mode-2 data discs
Disc capacity	600MB
Rotation speed: innermost track	530 r/min at CLV = 1.4 m/s
Rotation speed: outermost track	200 r/min at CLV = 1.2 m/s
Sustained data transfer rate	150KB/s
Burst data transfer rate	1.5MB/s
Access time: full stroke	650 ms
Access time: average	380 ms

**Table 4–12 RRD43 Compact Disc Drive Specifications**

<b>Subject</b>	<b>Description</b>
Acceptable discs	CD-ROM mode-1 data discs (Audio) CD-ROM mode-2 data discs (Data)
Disc capacity	600MB
Rotation speed: innermost track	530 r/min at CLV = 1.4 m/s (Audio) 1060 r/min at CLV = 1.4 m/s (Data)
Rotation speed: outermost track	200 r/min at CLV = 1.2 m/s (Audio) 400 r/min at CLV = 1.2 m/s (Data)
Sustained data transfer rate	150KB/s (Audio) 300KB/s (Data)
Burst data transfer rate	1.5MB/s (Asynch) 4.2MB/s (Synch)
Access time: full stroke	650 ms (Audio) 1000 ms (Data)
Access time: average	385 ms (Audio) 250 ms (Data)

### 4.3 KA53-AA CPU Specifications

The Model 105A system uses the timesharing KA53-AA CPU (54-21797-02).

---

#### Central Processing Unit

---

Addressing modes	General register: 8 Program counter: 4 Index: 9
Clock rate	333 MHz (12 ns cycle)
Data path width	64 bits
Number of data types	Hardware: 9 Software emulated: 7
Number of instructions	Hardware: 242 Microcode assisted: 21 Software emulated: 41
General purpose registers	16 (32-bit wide) Interval timer: 1 (programmable) Programmable timers: 2
I/O bus interface	One Q22-bus interface with 8192 entry scatter/gather map
Q-bus backplane termination	123 $\Omega$

---

#### Memory Management and Control

---

Page size	512 bytes
Virtual address space	4GB
Physical memory space	128MB
Number of memory sets	2 sets

---

#### Architecture

---

Instruction prefetch buffer size	16 bytes
Primary Cache	
Data stored	Instruction and data
Write algorithm	Write-through
Size	8KB

---

**Architecture**

---

Speed	12 nanoseconds (READ)
Associativity	Two-way
Back-up Cache	
Data stored	Instruction stream and data
Write algorithm	Write-back
Size	512 Kbytes
Speed	42 nanoseconds
Associativity	Direct mapped
Translation buffer	
Size	96 entry
Associativity	Fully associative
Q22-bus address translation	
Q22-bus map cache	
Size	16 entry
Associativity	Fully associative
Q22-bus I/O bus buffer size	
Input	32 bytes
Output	4 bytes
Q22-bus Maximum I/O bandwidth	
Block mode DMA read	2.4MB/second
Block mode DMA write	3.3MB/second

---

**Ethernet Port**

---

Supported protocols	Ethernet V2.0 (IEEE 802.3)
Supported media types	Standard or ThinWire
Data path width	1 bit
Data rate	10Mb/second
Buffer size	
Transmit buffer	128 bytes
Receiver buffer	128 bytes

---

**Digital Storage System Interconnect (DSSI)**

---

Number of DSSI interfaces	1 (or 2 with KFDDA option)
Maximum number of supported devices	7 (or 14 with KFDDA option)
Data path width	8 bits
Maximum bandwidth	4MB/second
Maximum queue I/O rate	1200/second
Buffer size	
Transmit buffer	256 bytes
Receiver buffer	256 bytes

---

**Console Serial Lines**

---

Interface standards	EIA RS-423-A/CCITT V.10 X.26 EIA RS-232-C/CCITT V.28 DEC-423
Data format	1 start bit, 8 data bits, 0 parity bits, 1 stop bit
Baud rates	300; 600; 1200; 2400; 4800; 9600; 19,200; 38,400

---

**Ordering Information**

---

Included as part of base system

---

**Operating System Support**

---

OpenVMS	Version 5.5-2H4 or higher
---------	---------------------------

---

**Diagnostic Support**

---

Self-tests	Yes
------------	-----

---

**Related Documentation**

---

EK-473AB-MG	<i>KA53/KA54 CPU System Maintenance</i>
EK-513AA-OP	<i>VAX 4000 Model 105A/106A Operator Information</i> (see Appendix A, Associated and Related Documents)

---

## 4.4 KA54-AA CPU Specifications

The Model 106A system uses the timesharing KA54-AA CPU (54-21797-03).

---

### Central Processing Unit

---

Addressing modes	General register: 8 Program counter: 4 Index: 9
Clock rate	400 MHz (10 ns cycle)
Data path width	64 bits
Number of data types	Hardware: 9 Software emulated: 7
Number of instructions	Hardware: 242 Microcode assisted: 21 Software emulated: 41
General purpose registers	16 (32-bit wide) Interval timer: 1 (programmable) Programmable timers: 2
I/O bus interface	One Q22-bus interface with 8192 entry scatter/gather map
Q-bus backplane termination	123 $\Omega$

---

### Memory Management and Control

---

Page size	512 bytes
Virtual address space	4GB
Physical memory space	128MB
Number of memory sets	2 sets

---

### Architecture

---

Instruction prefetch buffer size	16 bytes
Primary Cache	
Data stored	Instruction and data
Write algorithm	Write-through
Size	8KB

---

**Architecture**

---

Speed	10 nanoseconds (READ)
Associativity	Two-way
Back-up Cache	
Data stored	Instruction stream and data
Write algorithm	Write-back
Size	512 Kbytes
Speed	42 nanoseconds
Associativity	Direct mapped
Translation buffer	
Size	96 entry
Associativity	Fully associative
Q22-bus address translation	
Q22-bus map cache	
Size	16 entry
Associativity	Fully associative
Q22-bus I/O bus buffer size	
Input	32 bytes
Output	4 bytes
Q22-bus Maximum I/O bandwidth	
Block mode DMA read	2.4MB/second
Block mode DMA write	3.3MB/second

---

**Ethernet Port**

---

Supported protocols	Ethernet V2.0 (IEEE 802.3)
Supported media types	Standard or ThinWire
Data path width	1 bit
Data rate	10Mb/second
Buffer size	
Transmit buffer	128 bytes
Receiver buffer	128 bytes

---

**Digital Storage System Interconnect (DSSI)**

---

Number of DSSI interfaces	1 or 2 (with KFDDA option)
Maximum number of supported devices	7 or 14
Data path width	8 bits
Maximum bandwidth	4MB/second
Maximum queue I/O rate	1200/second
Buffer size	
Transmit buffer	256 bytes
Receiver buffer	256 bytes

---

**Console Serial Lines**

---

Interface standards	EIA RS-423-A/CCITT V.10 X.26 EIA RS-232-C/CCITT V.28 DEC-423
Data format	1 start bit, 8 data bits, 0 parity bits, 1 stop bit
Baud rates	300; 600; 1200; 2400; 4800; 9600; 19,200; 38,400

---

**Ordering Information**

---

Included as part of base system

---

**Operating System Support**

---

OpenVMS	Version 5.5-2H4 or higher
---------	---------------------------

---

**Diagnostic Support**

---

Self-tests	Yes
------------	-----

---

**Related Documentation**

---

EK-473AB-MG	<i>KA53/KA54 CPU System Maintenance</i>
EK-513AA-OP	<i>VAX 4000 Model 105A/106A Operator Information (see Appendix A, Associated and Related Documents)</i>

---



---

# Index

## A

---

- Alternative boot devices, 2–10
- Asynchronous communications devices
  - DHW42-AA, 1–6
  - DHW42-BA, 1–6
  - DHW42-CA, 1–6
  - DHW42-UP, 1–6

## B

---

- Binary load and unload (X command), 3–26
- Boot
  - device, 2–10
    - recovery action, 2–11
- BOOT command, 2–5, 3–1
  - use of, 2–9
- Boot device
  - alternatives, 2–10
  - default, 2–10
  - device names, 2–10
  - resetting default, 2–10
- Break enable switch
  - use of, 2–4
- Break enable switch LED
  - meaning, 2–4
- Break key
  - halting the system, 2–4

## C

---

- Cables
  - synchronous option, 1–6
- Commands
  - for unprivileged users, 2–5
- Comment command (!), 3–28
- ! (comment command), 3–28
- Communications devices
  - asynchronous, 1–6
  - synchronous, 1–6
- Compact disc drives
  - RRD42, 1–5
  - RRD43, 1–5
- Console command
  - LOGIN, 3–10
- Console commands
  - binary load and unload (X), 3–26
  - BOOT, 3–1
  - ! (comment), 3–28
  - CONTINUE, 3–3
  - DEPOSIT, 3–3
  - EXAMINE, 3–4
  - FIND, 3–6
  - HALT, 3–6
  - HELP, 3–7
  - INITIALIZE, 3–9
  - MOVE, 3–11
  - NEXT, 3–12
  - REPEAT, 3–14
  - SEARCH, 3–15
  - SET, 3–17
  - SHOW, 3–18
  - START, 3–21

## Console commands (cont'd)

TEST, 3-22

UNJAM, 3-26

X (binary load and unload), 3-26

## Console mode

entering, 2-2

privileged, 2-7

## console port

MMJ port 3, 2-4

use of, 2-4

## Console port, 2-4

## Console prompt, 2-2

## Console security feature

description, 2-5

disabling, 2-9

enabling, 2-7

values, 3-17

## CONTINUE command, 3-3

use of, 2-9

## CPU

KA53, 1-1

KA54, 1-1

## D

---

### Defaults

boot device, 2-10

recovery action, 2-11

### DEPOSIT command, 3-3

### Device names

boot device, 2-10

### Dimensions

system unit, 4-3

### Disk drives

RF31T, 1-5

RF35, 1-5

RF36, 1-5

## E

---

### EXAMINE command, 3-4

## F

---

### Factory installed software, 1-5, 2-10

### Features

Model 105A, 1-1

Model 106A, 1-1

### FIND command, 3-6

FIS, 1-5, 2-10

## H

---

### Halt

recovery action, 2-11

### Halt button

use of, 2-2, 2-4

### HALT command, 3-6

use of, 2-9

### Halting

system, 2-4

### Hardware specifications

RF31T hard disk drive, 4-5

RF35 hard disk drive, 4-5

RRD42 compact disc drive, 4-8

RRD43 compact disc drive, 4-8

system unit, 4-1

TLZK06 cassette tape drive, 4-7

TLZK07 cassette tape drive, 4-8

TZ30 tape drive, 4-6

TZK10 QIC tape drive, 4-6

TZK11 QIC tape drive, 4-7

### HELP command, 3-7

## I

---

### INITIALIZE command, 3-9

## K

---

### KA53-AA modules

system names, 4-10

### KA54-AA modules

system names, 4-13

## L

---

LOGIN command, 2-5, 3-10  
use of, 2-7, 2-9

## M

---

Mass storage devices  
internal, 1-5  
MMJ port 0  
as console port, 2-4  
MMJ port 3  
alternative console port, 2-4  
Model 105A  
features, 1-1  
KA53 CPU, 1-1  
system description, 1-1  
VAX architecture support, 1-3  
Model 106A  
features, 1-1  
KA54 CPU, 1-1  
system description, 1-1  
VAX architecture support, 1-3  
MOVE command, 3-11

## N

---

NEXT command, 3-12  
Nonoperating conditions  
system specifications, 4-4  
NVAX processor, 1-1

## O

---

Operating conditions  
system specifications, 4-3  
Operating system  
shutting down, 2-2

## P

---

Password  
security password, 2-6  
Privileged console mode  
exiting, 2-9  
logging in to, 2-7  
use of, 2-7  
Privileged user  
definition, 2-5

## R

---

Recovery action  
actions, 2-11  
default, 2-11  
resetting default, 2-11  
REPEAT command, 3-14  
Restart  
recovery action, 2-11  
RF31T  
hardware specifications, 4-5  
RF35  
hardware specifications, 4-5  
RRD42 compact disc drive  
hardware specifications, 4-8  
RRD43 compact disc drive  
hardware specifications, 4-8

## S

---

SEARCH command, 3-15  
Security password  
changing, 2-8  
entering, 2-6, 2-7  
setting, 2-6  
verifying, 2-6  
SET BOOT command  
use of, 2-10  
SET command, 3-17  
SET HALT command  
boot, 2-11  
halt, 2-11  
restart, 2-11  
use of, 2-11

SET HOST/DUP command, 3-17  
SET PASSWORD command  
  use of, 2-6  
SET PSE command  
  use of, 2-7, 2-9  
SET PSWD command  
  use of, 2-8  
SHOW command, 3-18  
START command, 3-21  
  use of, 2-9  
Storage conditions  
  system unit, 4-3  
Storage devices  
  compact disc drives, 1-5  
  disk drives, 1-5  
  diskette drives, 1-5  
  tape drives, 1-5  
Support  
  VAX architecture, 1-3  
Synchronous communications devices  
  DSW42-AA, 1-6  
Synchronous option cables, 1-6  
System description  
  Model 105A, 1-1  
  Model 106A, 1-1  
System disk, 1-5, 2-10  
System specifications  
  nonoperating conditions, 4-4  
  operating conditions, 4-3  
System unit  
  dimensions, 4-3  
  hardware specifications, 4-1  
  storage conditions, 4-3

## T

---

Tape drives  
  TLZ06/TLZ07, 1-5  
  TZ30, 1-5  
  TZK10/TZK11, 1-5  
TEST command, 3-22  
TLZ06 cassette tape drive  
  hardware specifications, 4-7

TLZ07 cassette tape drive  
  hardware specifications, 4-8  
TZ30 tape drive  
  hardware specifications, 4-6  
TZK10 QIC tape drive  
  hardware specifications, 4-6  
TZK11 QIC tape drive  
  hardware specifications, 4-7

## U

---

UNJAM command, 3-26  
Unprivileged user  
  definition, 2-5

## V

---

VAX  
  architecture support, 1-3  
VAX architecture support  
  Model 105A, 1-3  
  Model 106A, 1-3  
VAX instructions  
  support of, 1-3

## X

---

X command (binary load and unload), 3-26

## Reader's Comments

VAX 4000 Model 105A/106A  
Customer Technical Information  
EK-514AA-TI. B01

---

Your comments and suggestions help us improve the quality of our publications.

Thank you for your assistance.

<b>I rate this manual's:</b>	<b>Excellent</b>	<b>Good</b>	<b>Fair</b>	<b>Poor</b>
Accuracy (product works as manual says)	<input type="checkbox"/>	<input type="checkbox"/>	<input type="checkbox"/>	<input type="checkbox"/>
Completeness (enough information)	<input type="checkbox"/>	<input type="checkbox"/>	<input type="checkbox"/>	<input type="checkbox"/>
Clarity (easy to understand)	<input type="checkbox"/>	<input type="checkbox"/>	<input type="checkbox"/>	<input type="checkbox"/>
Organization (structure of subject matter)	<input type="checkbox"/>	<input type="checkbox"/>	<input type="checkbox"/>	<input type="checkbox"/>
Figures (useful)	<input type="checkbox"/>	<input type="checkbox"/>	<input type="checkbox"/>	<input type="checkbox"/>
Examples (useful)	<input type="checkbox"/>	<input type="checkbox"/>	<input type="checkbox"/>	<input type="checkbox"/>
Index (ability to find topic)	<input type="checkbox"/>	<input type="checkbox"/>	<input type="checkbox"/>	<input type="checkbox"/>
Page layout (easy to find information)	<input type="checkbox"/>	<input type="checkbox"/>	<input type="checkbox"/>	<input type="checkbox"/>

I would like to see more/less \_\_\_\_\_

What I like best about this manual is \_\_\_\_\_

What I like least about this manual is \_\_\_\_\_

I found the following errors in this manual:

Page	Description
_____	_____
_____	_____
_____	_____

Additional comments or suggestions to improve this manual:

For software manuals, please indicate which version of the software you are using: \_\_\_\_\_

Name/Title \_\_\_\_\_ Dept. \_\_\_\_\_

Company \_\_\_\_\_ Date \_\_\_\_\_

Mailing Address \_\_\_\_\_

Phone \_\_\_\_\_

Do Not Tear - Fold Here and Tape

**digital**™

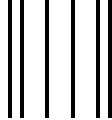

No Postage  
Necessary  
If Mailed  
in the  
United States

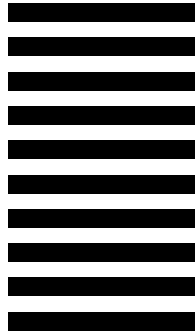

**BUSINESS REPLY MAIL**  
FIRST CLASS PERMIT NO. 33 MAYNARD MASS.

POSTAGE WILL BE PAID BY ADDRESSEE

DIGITAL EQUIPMENT CORPORATION  
Shared Engineering Services  
MLO5-5/E76  
2 THOMPSON STREET  
MAYNARD, MA 01754-1716



Do Not Tear - Fold Here