

**ILLUSTRATED
PARTS
BREAKDOWN**

**VAX 4000
Models 5xxA/6xxA/7xxA
Series Systems**

ILLUSTRATED PARTS BREAKDOWN (IPB)

The IPB is used to identify a part and its location in a hardware product. The document references specific item numbers in the associated parts list.

HOW TO USE THE IPB

1. Locate the figure containing the item of interest.
2. Locate the number (callout) of the item of interest.
3. Locate that item number in the associated parts list.

FORMAT

Each IPB is generally organized based on its first figure. All other assemblies and subassemblies are referenced from this figure. Each figure contains numeric callouts of all major parts (items).

PARTS LIST

Each parts list contains the following:

Figure and Item No. – Lists the figure number and its referenced numeric callout

Description – Presents the name and a brief description of the item. A single asterisk (*) preceding the description denotes item is a

subassembly to its referenced figure. A double asterisk (**) preceding the description indicates that this item is subordinate to the preceding single asterisk item.

DEC Part No. – Lists the Digital/Vendor part number. The letter in the column heading indicates the current revision level of the Engineering Drawing for the referenced figure.

ECO Cut-In – Lists the top assembly drawing number and revision level at first printing. All additional revisions to an item are listed in this column.

Used On Code – Lists letters referring to the product variation assigned in Figure 1. When this column is blank, the item is used in all variations.

Ref Fig No. – Lists a cross reference between figures within the IPB.

PART NUMBER/PART DESCRIPTION INDEX SECTION

Lists items by part number numerically, and description alphabetically. Items are also referenced to a location within the IPB by figure and item number.

ECO/REVISION HISTORY

**OTHER IPB
MANUALS
REFERENCED**

FIGURE NO.	ASSEMBLY	INITIAL LEVEL	CURRENT LEVEL	PRINTING DATE	OTHER IPB MANUALS REFERENCED
1	681QJ	00000	00000	28-JUN-94	EK-440AB-IP
2	691QJ	00000	00001		
3	692QJ	00000	00000		
4	694QJ	00000	00000		
5	70-27400	00002	00002		

Digital Equipment Corporation reserves the right, without notice, to make substitutions and modifications in the specifications of products documented in this manual and further reserves the right to withdraw any of these products from the market without notice.

Digital Equipment Corporation is not responsible for errors which may appear in the technical description (including illustrations and photographs) of the products covered by this manual.

None of the descriptions contained in this manual imply the granting of any license whatsoever to make, use or sell equipment constructed in accordance therewith.

Restricted Rights: Use, duplication or disclosure by the U.S. Government is subject to restrictions as set forth in subparagraph (c) (1) (ii) of the Rights in Technical Data and Computer Software clause at DFARS 252.227-2713.

Copyright © 1993, 1994 by Digital Equipment Corporation. All rights reserved.
Printed in U.S.A.

The postage-paid READER'S COMMENTS form on the last page of this document requests your critical evaluation to assist us in preparing future documentation.

The following are trademarks of Digital Equipment Corporation :

DECdirect, Q-bus, ThinWire, VAX and the DIGITAL logo.

VAX 4000
Model 500A

THIS PAGE INTENTIONALLY LEFT BLANK

 INDICATES FRU LEVEL PARTS.

PARTS LIST 

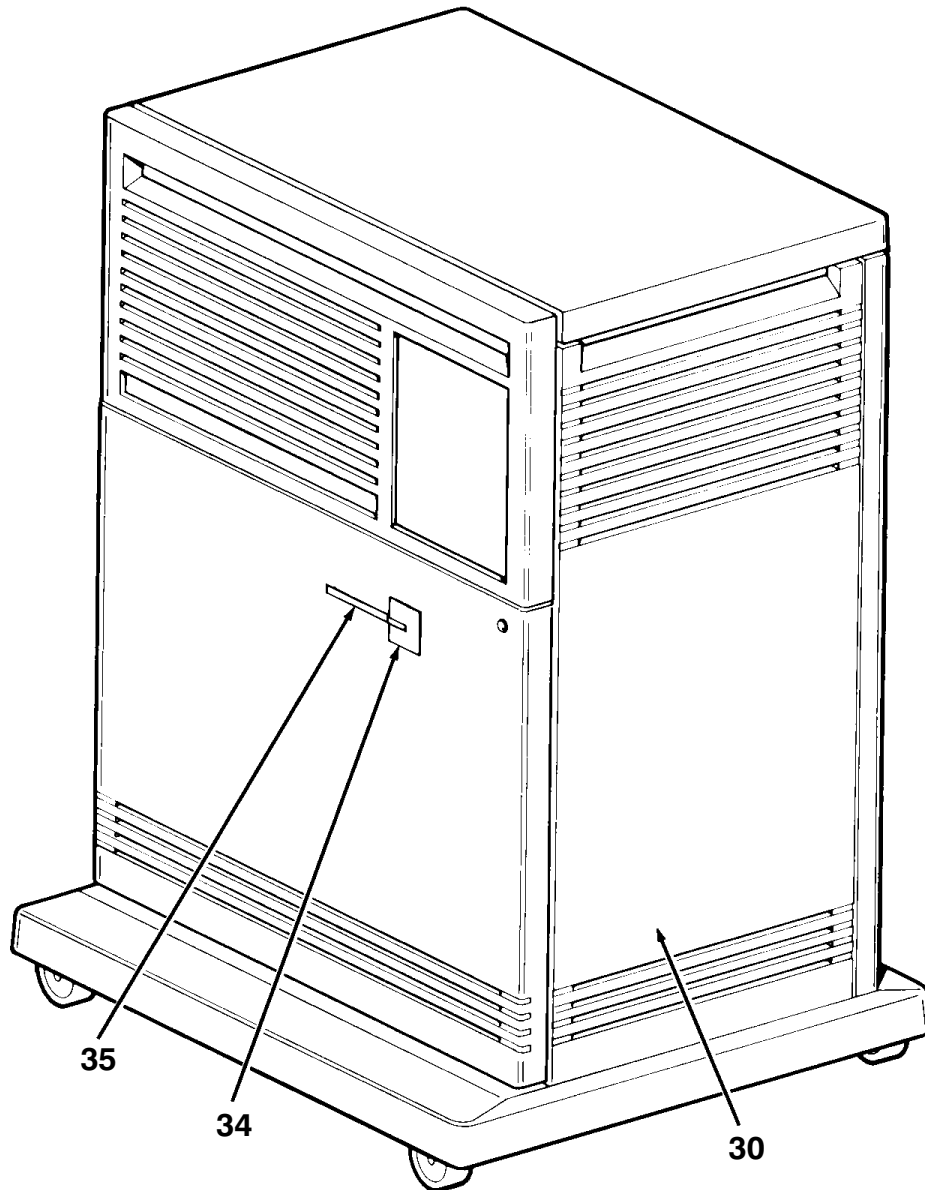

M567A-01-SC

Figure 1. 681QJ Pedestal System (Sheet 1 of 2)

 INDICATES FRU LEVEL PARTS.

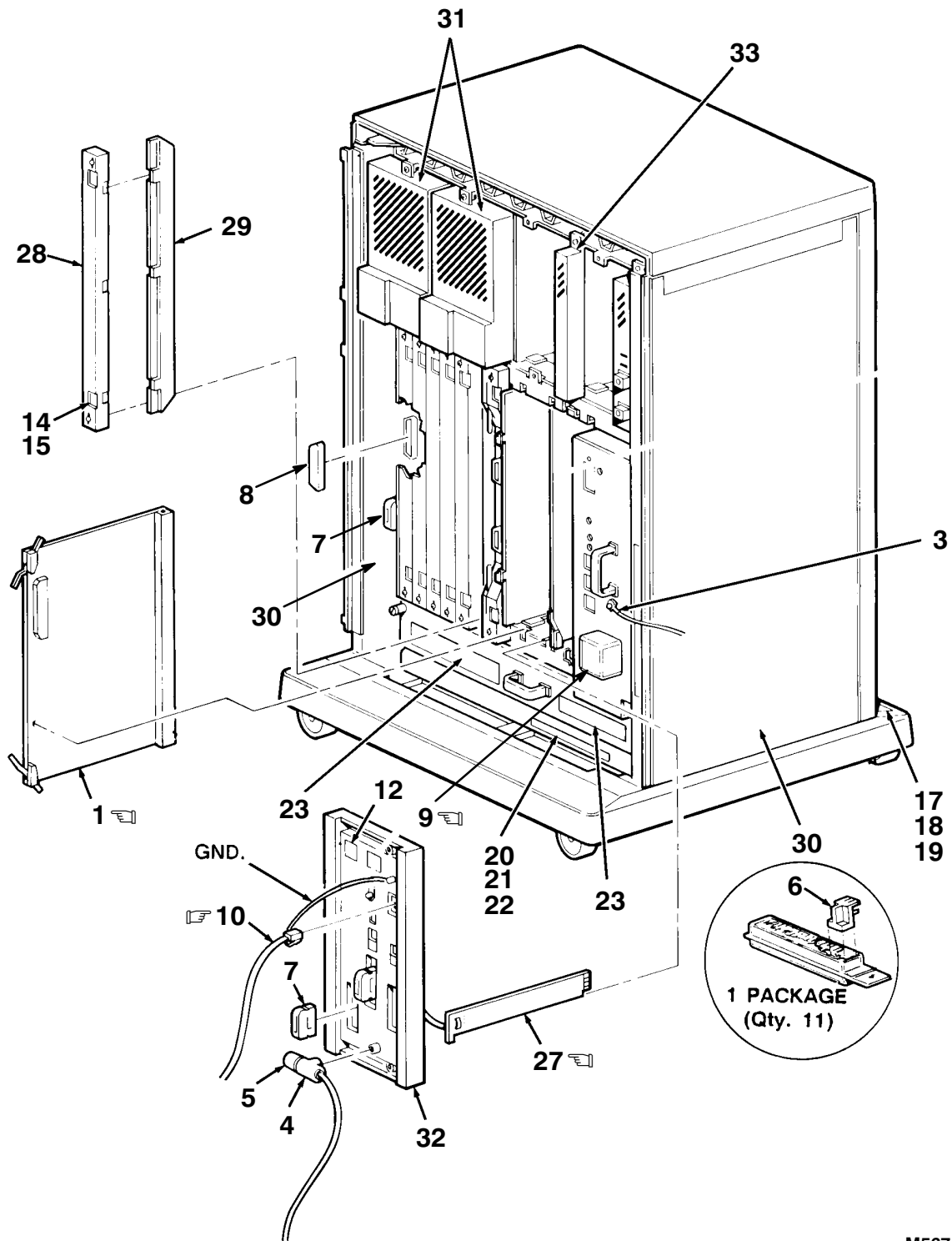

M567A-01A-SC

Figure 1. 681QJ Pedestal System (Sheet 2 of 2)

FIG. & ITEM NO.	DESCRIPTION	DIGITAL PART NO. ^A	ECO CUT-IN 681QJ 00000	USED ON CODE	REF FIG NO.
1-	681QJ PEDESTAL SYSTEM	681QJ-B9			
☞ 1	*Module, NVAX CPU, 14NS, 128 KB CACHE	L4005-BA			
2	*Kit, Q-bus Grant Continuity (See Note 1)	M9047-SA			
3	*Strap, Ground w/Label	12-13756-A8			
4	*Tee, BNC Coaxial	12-25869-01			
5	*Connector, BNC Coaxial	12-26318-01			
6	*Encoder Set, Lens (DSSI Unit ID Plug)	12-28766-19			
7	*Connector, Terminator	12-29258-01			
8	*Cover, 50-Pin IDC Connector	12-33377-01			
☞ 9	*Power Cord, 120V 10A (2.5M) (BN20A-2E) (See Note 2)	17-00083-43			
☞ 10	*Cable Assembly, 06 Conductor	17-01364-02			
11	*Label, "Switch Marker F/RA70" (Not Shown)	36-18940-02			
12	*Label, "Module Number, S-Box L4005-BA"	36-26883-D2			
13	*Label, "Pre-Installed Software" (Not Shown)	36-28979-01			
14	*Label, "BA2XX Rev" (Rolled)	36-29163-07			
15	*Label, "BA2XX Rev" (Sheeted)	36-29164-07			
16	*Label, "Postcard FTZ" (Not Shown)	36-30422-52			
17	*Label, "BA400 Series KA681" (US)	36-32667-23			
18	*Label, "BA400 Series KA681" (Canada)	36-32667-26			
19	*Label, "BA400 Series KA681" (UK)	36-32667-29			
20	*Label, "BA440 Serial/Model" (US)	36-32668-01			
21	*Label, "BA440 Serial/Model" (UK)	36-32668-02			
22	*Label, "BA440 Serial/Model" (Canada)	36-32668-03			
23	*Label, "Logo/Model VAX 4000-500A"	36-33152-16			
24	*Label, "Telecom Approval" (Not Shown)	36-33180-18			
25	*Label, "DSSI Booklet" (Not Shown)	36-40022-01			
26	*Package Assembly (Not Shown)	37-01072-07			
☞ 27	*Module, Power Harness	54-19789-01			
28	*Bulkhead Assembly, Front	70-23981-01			
29	*Panel Assembly, Gap Filler	70-24071-01			
30	*Chassis Assembly (See IPB Manual EK-440AB-IP)	70-26699-02			
31	*Bezel Assembly, Disk Drive	70-27049-02			
32	*BULKHEAD ASSEMBLY, H3604 CONSOLE	70-27400-01			5
33	*Bezel Assembly, Filler	70-27414-01			
34	*Medallion, VAX 4000-500A	74-40913-20			
35	*Strip, Color	74-40914-01			
36	*Bag, 2 Mil Thick, Poly Reclose (Not Shown)	99-06557-30			
	NOTE 1: This Item Not Shown, Use As Required. NOTE 2: Reference Index For 240V Power Cords.				

THIS PAGE INTENTIONALLY LEFT BLANK

VAX 4000
Models 600A and 505A

THIS PAGE INTENTIONALLY LEFT BLANK

 INDICATES FRU LEVEL PARTS.

PARTS LIST 

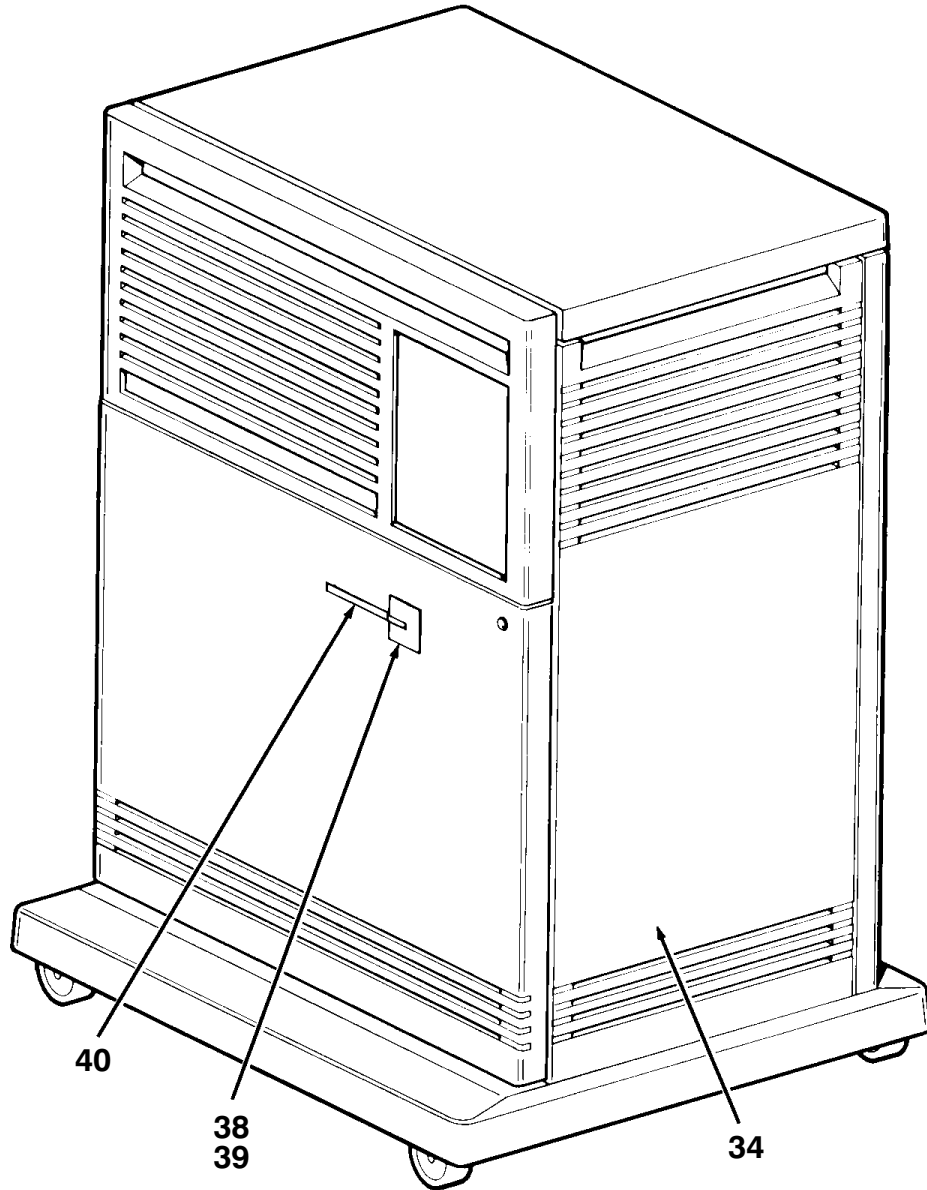

M567A-02-SC

Figure 2. 691QJ Pedestal System (Sheet 1 of 2)

 INDICATES FRU LEVEL PARTS.

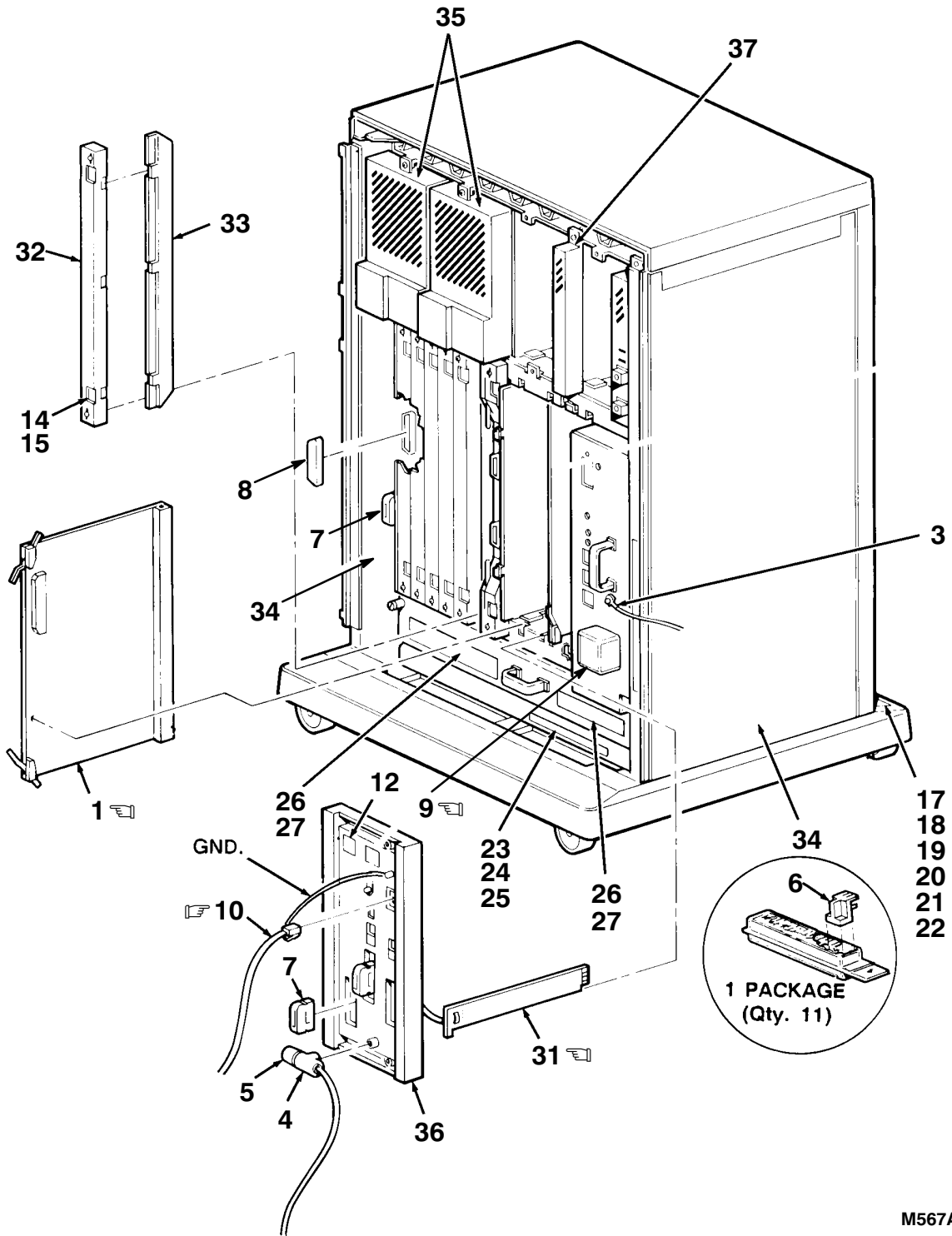

M567A-02A-SC

Figure 2. 691QJ Pedestal System (Sheet 2 of 2)

FIG. & ITEM NO.	DESCRIPTION	DIGITAL PART NO. ^B	ECO CUT-IN 691QJ 00000	USED ON CODE	REF FIG NO.
2-	691QJ PEDESTAL SYSTEM				
	Code A – Model 691QJ–B9	691QJ–B9		A	
	Code B – Model 691QJ–C9 (added)	691QJ–C9	00001	B	
☞ 1	*Module, NVAX CPU, 12NS, 512 KB CACHE	L4005–AA			
2	*Kit, Q–bus Grant Continuity (See Note 1)	M9047–SA			
3	*Strap, Ground w/Label	12–13756–A8			
4	*Tee, BNC Coaxial	12–25869–01			
5	*Connector, BNC Coaxial	12–26318–01			
6	*Encoder Set, Lens (DSSI Unit ID Plug)	12–28766–19			
7	*Connector, Terminator	12–29258–01			
8	*Cover, 50–Pin IDC Connector	12–33377–01			
☞ 9	*Power Cord, 120V 10A (2.5M) (BN20A–2E) (See Note 2)	17–00083–43			
☞ 10	*Cable Assembly, 06 Conductor	17–01364–02			
11	*Label, “Switch Marker F/RA70” (Not Shown)	36–18940–02			
12	*Label, “Module Number, S–Box L4005–AA”	36–26883–D1			
13	*Label, “Pre–Installed Software” (Not Shown)	36–28979–01			
14	*Label, “BA2XX Rev” (Rolled)	36–29163–07			
15	*Label, “BA2XX Rev” (Sheeted)	36–29164–07			
16	*Label, “Postcard FTZ” (Not Shown)	36–30422–52			
17	*Label, “BA400 Series KA691” (US)	36–32667–25		A	
18	*Label, “BA400 Series KA691” (Canada)	36–32667–28		A	
19	*Label, “BA400 Series KA691” (UK)	36–32667–31		A	
20	*Label, “BA400 Series KA691” (Canada) (added)	36–32667–41	00001	B	
21	*Label, “BA400 Series KA691” (US) (added)	36–32667–42	00001	B	
22	*Label, “BA400 Series KA691” (UK) (added)	36–32667–43	00001	B	
23	*Label, “BA440 Serial/Model” (US)	36–32668–01			
24	*Label, “BA440 Serial/Model” (UK)	36–32668–02			
25	*Label, “BA440 Serial/Model” (Canada)	36–32668–03			
26	*Label, “Logo/Model VAX 4000–600A”	36–33152–15		A	
27	*Label, “Logo/Model VAX 4000–505A” (added)	36–33152–20	00001	B	
28	*Label, “Telecom Approval” (Not Shown)	36–33180–18			
29	*Label, “DSSI Booklet” (Not Shown)	36–40022–01			
30	*Package Assembly (Not Shown)	37–01072–07			
☞ 31	*Module, Power Harness	54–19789–01			
32	*Bulkhead Assembly, Front	70–23981–01			
33	*Panel Assembly, Gap Filler	70–24071–01			
34	*Chassis Assembly (See IPB Manual EK–440AB–IP)	70–26699–02			
35	*Bezel Assembly, Disk Drive	70–27049–02			
	NOTE 1: This Item Not Shown, Use As Required. NOTE 2: Reference Index For 240V Power Cords.				

FIG. & ITEM NO.	DESCRIPTION	DIGITAL PART NO. ^B	ECO CUT-IN 691QJ 00000	USED ON CODE	REF FIG NO.
2-	691QJ PEDESTAL SYSTEM (continued)				
36	*BULKHEAD ASSEMBLY, H3604 CONSOLE	70-27400-01			5
37	*Bezel Assembly, Filler	70-27414-01			
38	*Medallion, VAX 4000-600A	74-40913-19		A	
39	*Medallion, VAX 4000-505A (added)	74-40912-25	00001	B	
40	*Strip, Color	74-40914-01			
41	*Bag, 2 Mil Thick, Poly Reclose (Not Shown)	99-06557-30			

VAX 4000
Model 700A

THIS PAGE INTENTIONALLY LEFT BLANK

 INDICATES FRU LEVEL PARTS.

PARTS LIST 

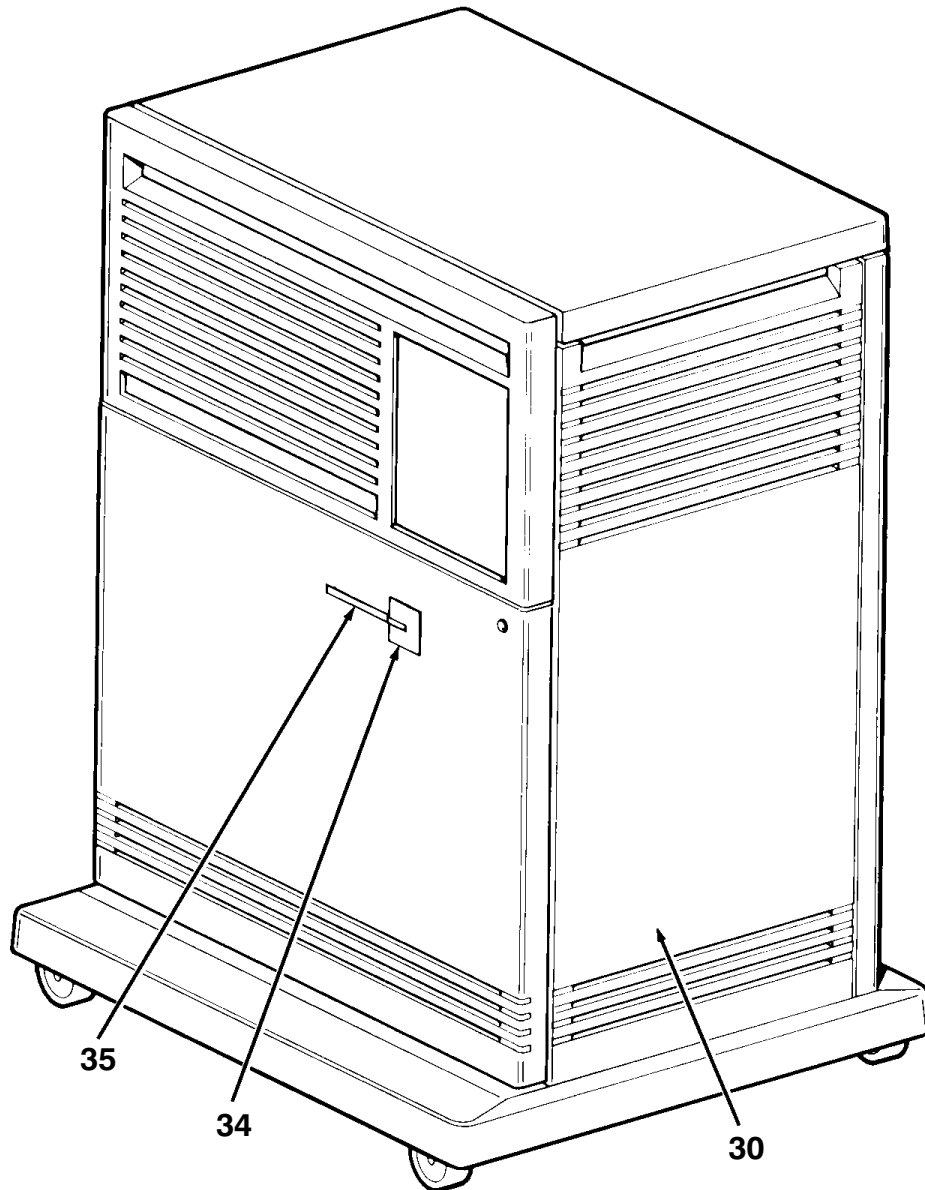

M567A-03-SC

Figure 3. 692QJ Pedestal System (Sheet 1 of 2)

INDICATES FRU LEVEL PARTS.

PARTS LIST

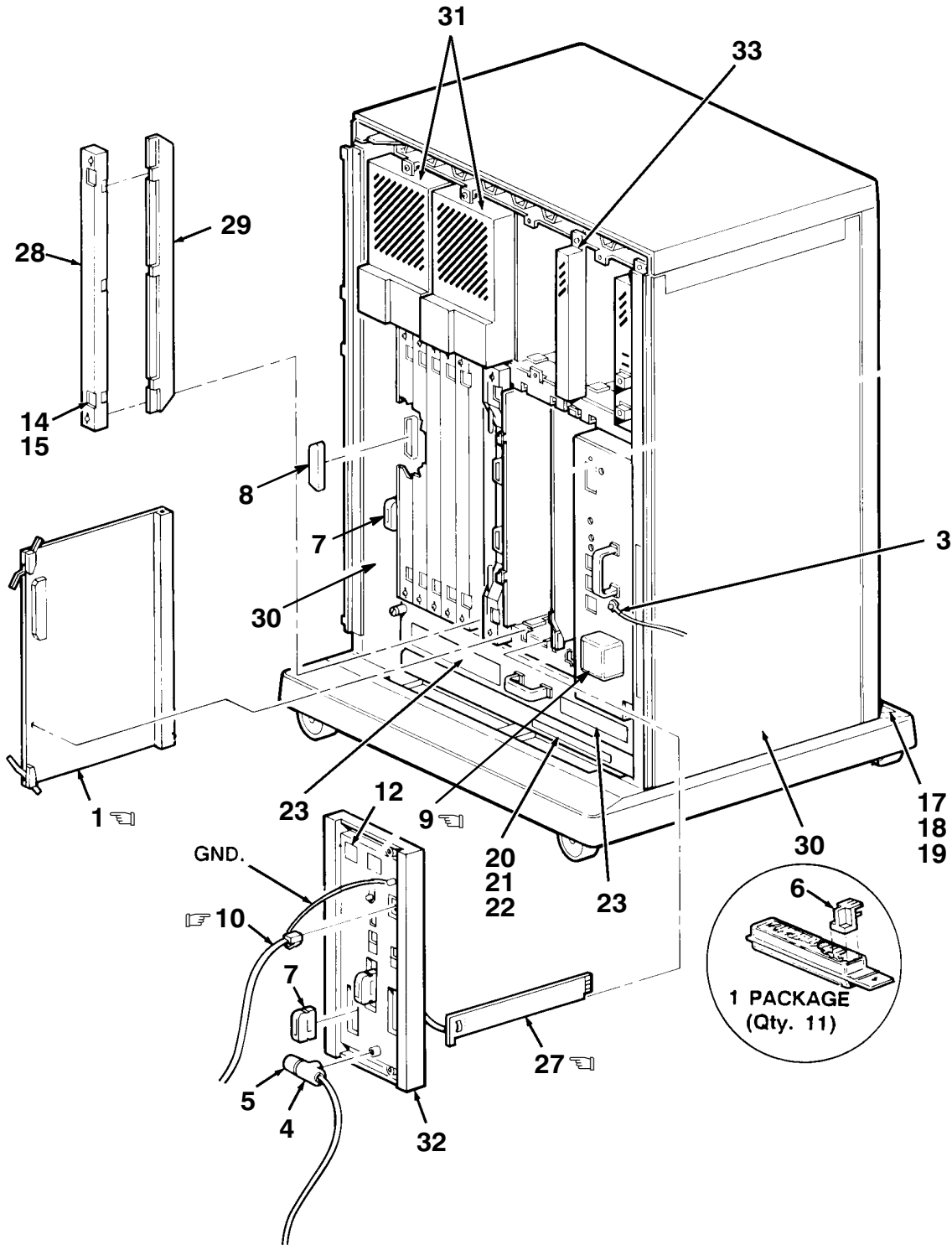

M567A-03A-SC

Figure 3. 692QJ Pedestal System (Sheet 2 of 2)

FIG. & ITEM NO.	DESCRIPTION	DIGITAL PART NO. ^A	ECO CUT-IN 692QJ 00000	USED ON CODE	REF FIG NO.
3-	692QJ PEDESTAL SYSTEM	692QJ-B9			
☞ 1	*Module, NVAX CPU, 10NS, 2 MB CACHE	L4006-AA			
2	*Kit, Q-bus Grant Continuity (See Note 1)	M9047-SA			
3	*Strap, Ground w/Label	12-13756-A8			
4	*Tee, BNC Coaxial	12-25869-01			
5	*Connector, BNC Coaxial	12-26318-01			
6	*Encoder Set, Lens (DSSI Unit ID Plug)	12-28766-19			
7	*Connector, Terminator	12-29258-01			
8	*Cover, 50-Pin IDC Connector	12-33377-01			
☞ 9	*Power Cord, 120V 10A (2.5M) (BN20A-2E) (See Note 2)	17-00083-43			
☞ 10	*Cable Assembly, 06 Conductor	17-01364-02			
11	*Label, "Switch Marker F/RA70" (Not Shown)	36-18940-02			
12	*Label, "Module Number, S-Box L4006-AA"	36-26883-D0			
13	*Label, "Pre-Installed Software" (Not Shown)	36-28979-01			
14	*Label, "BA2XX Rev" (Rolled)	36-29163-07			
15	*Label, "BA2XX Rev" (Sheeted)	36-29164-07			
16	*Label, "Postcard FTZ" (Not Shown)	36-30422-52			
17	*Label, "BA400 Series KA692" (US)	36-32667-24			
18	*Label, "BA400 Series KA692" (Canada)	36-32667-27			
19	*Label, "BA400 Series KA692" (UK)	36-32667-30			
20	*Label, "BA440 Serial/Model" (US)	36-32668-01			
21	*Label, "BA440 Serial/Model" (UK)	36-32668-02			
22	*Label, "BA440 Serial/Model" (Canada)	36-32668-03			
23	*Label, "Logo/Model VAX 4000-700A"	36-33152-17			
24	*Label, "Telecom Approval" (Not Shown)	36-33180-18			
25	*Label, "DSSI Booklet" (Not Shown)	36-40022-01			
26	*Package Assembly (Not Shown)	37-01072-07			
☞ 27	*Module, Power Harness	54-19789-01			
28	*Bulkhead Assembly, Front	70-23981-01			
29	*Panel Assembly, Gap Filler	70-24071-01			
30	*Chassis Assembly (See IPB Manual EK-440AB-IP)	70-26699-02			
31	*Bezel Assembly, Disk Drive	70-27049-02			
32	*BULKHEAD ASSEMBLY, H3604 CONSOLE	70-27400-01			5
33	*Bezel Assembly, Filler	70-27414-01			
34	*Medallion, VAX 4000-700A	74-40913-21			
35	*Strip, Color	74-40914-01			
36	*Bag, 2 Mil Thick, Poly Reclose (Not Shown)	99-06557-30			
	NOTE 1: This Item Not Shown, Use As Required. NOTE 2: Reference Index For 240V Power Cords.				

THIS PAGE INTENTIONALLY LEFT BLANK

VAX 4000
Model 705A

THIS PAGE INTENTIONALLY LEFT BLANK

 INDICATES FRU LEVEL PARTS.

PARTS LIST 

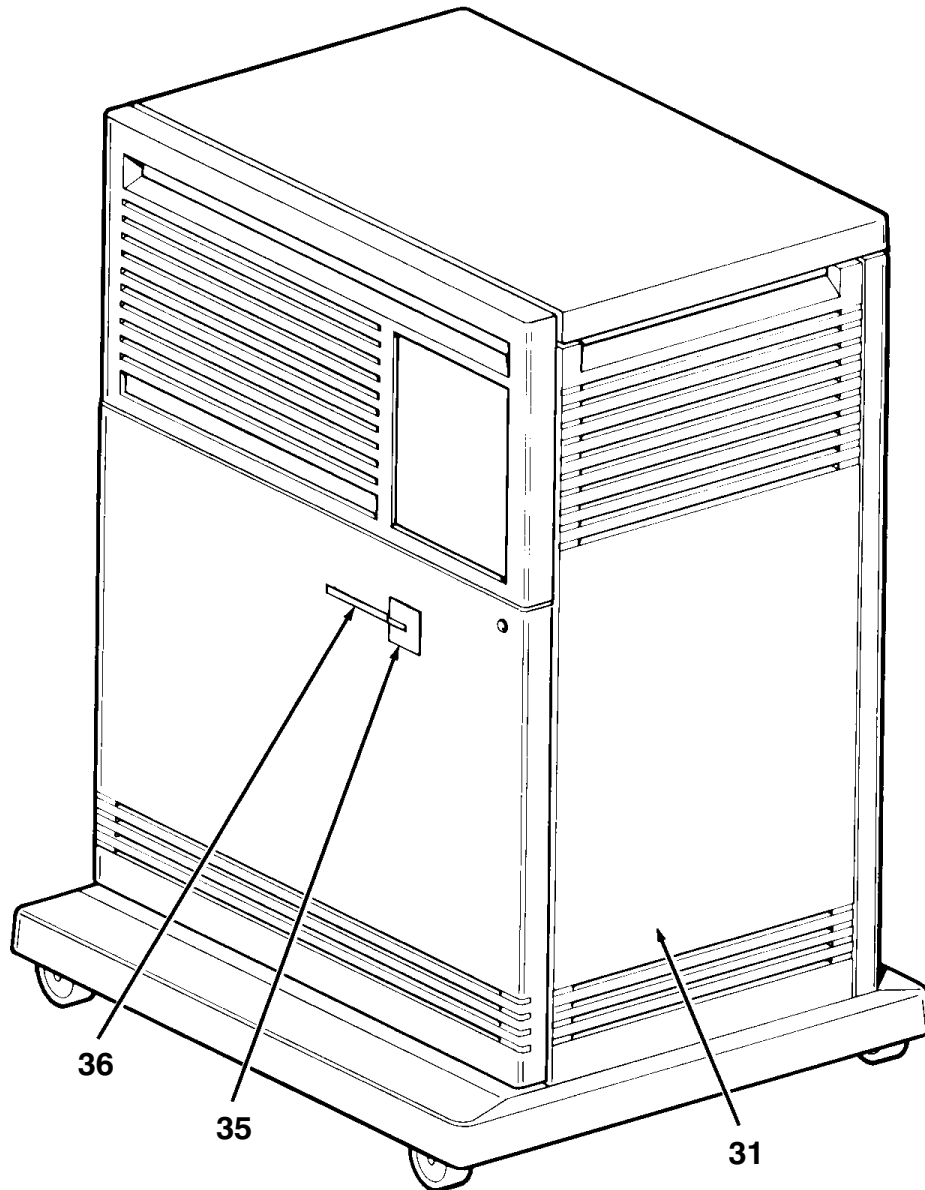

M567A-04-SC

Figure 4. 694QJ Pedestal System (Sheet 1 of 2)

INDICATES FRU LEVEL PARTS.

PARTS LIST

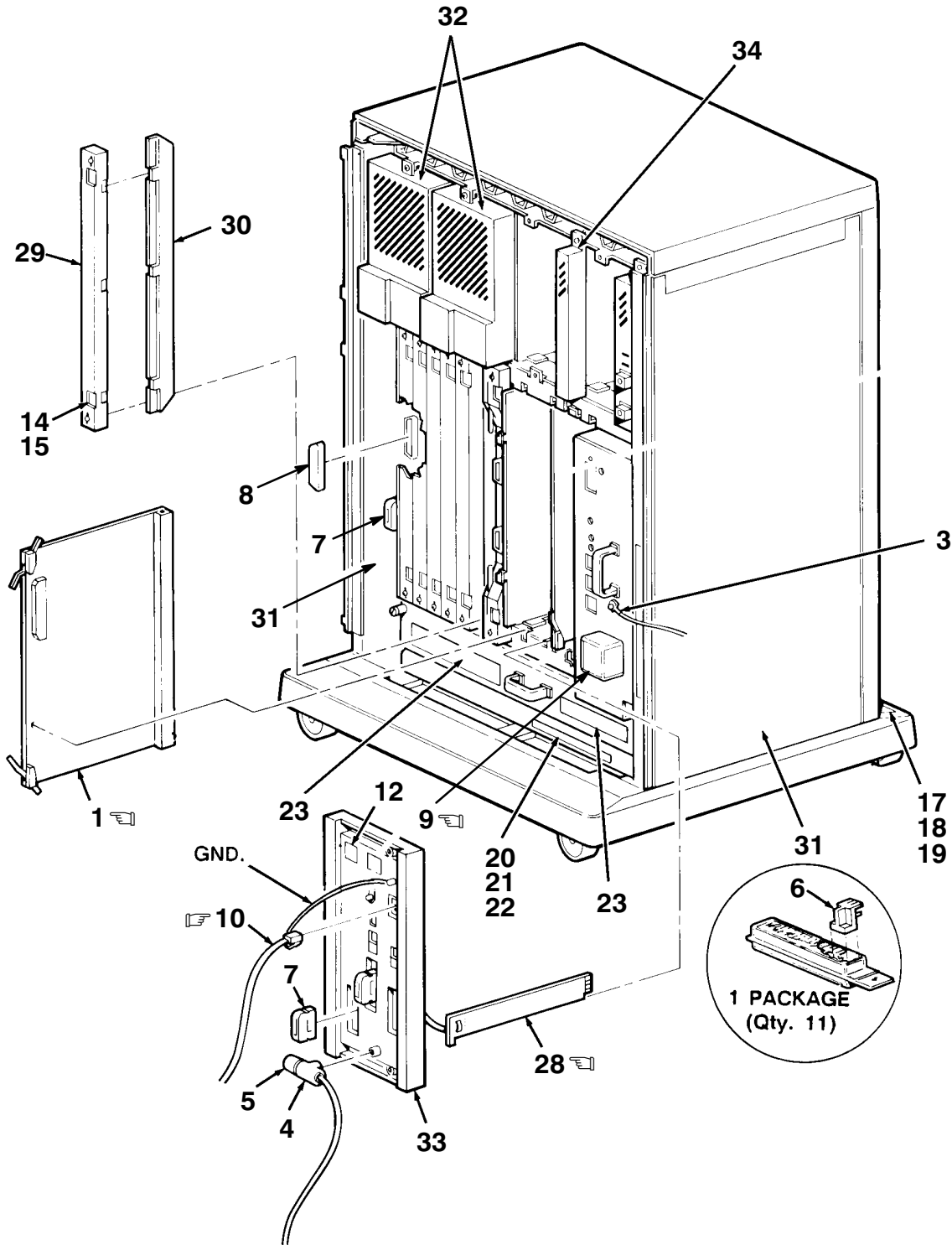

M567A-04A-SC

Figure 4. 694QJ Pedestal System (Sheet 2 of 2)

FIG. & ITEM NO.	DESCRIPTION	DIGITAL PART NO. ^A	ECO CUT-IN 694QJ 00000	USED ON CODE	REF FIG NO.
4-	694QJ PEDESTAL SYSTEM	694QJ-B9			
☞ 1	*Module, NVAX CPU, 9NS, 2 MB CACHE	L4006-BA			
2	*Kit, Q-bus Grant Continuity (See Note 1)	M9047-SA			
3	*Strap, Ground w/Label	12-13756-A8			
4	*Tee, BNC Coaxial	12-25869-01			
5	*Connector, BNC Coaxial	12-26318-01			
6	*Encoder Set, Lens (DSSI Unit ID Plug)	12-28766-19			
7	*Connector, Terminator	12-29258-01			
8	*Cover, 50-Pin IDC Connector	12-33377-01			
☞ 9	*Power Cord, 120V 10A (2.5M) (BN20A-2E) (See Note 2)	17-00083-43			
☞ 10	*Cable Assembly, 06 Conductor	17-01364-02			
11	*Label, "Switch Marker F/RA70" (Not Shown)	36-18940-02			
12	*Label, "Module Number, S-Box L4006-BA"	36-26883-D8			
13	*Label, "Pre-Installed Software" (Not Shown)	36-28979-01			
14	*Label, "BA2XX Rev" (Rolled)	36-29163-07			
15	*Label, "BA2XX Rev" (Sheeted)	36-29164-07			
16	*Label, "Postcard FTZ" (Not Shown)	36-30422-52			
17	*Label, "BA400 Series KA694" (US)	36-32667-35			
18	*Label, "BA400 Series KA694" (UK)	36-32667-36			
19	*Label, "BA400 Series KA694" (Canada)	36-32667-37			
20	*Label, "BA440 Serial/Model" (US)	36-32668-01			
21	*Label, "BA440 Serial/Model" (UK)	36-32668-02			
22	*Label, "BA440 Serial/Model" (Canada)	36-32668-03			
23	*Label, "Logo/Model VAX 4000-705A"	36-33152-21			
24	*Label, "Telecom Approval" (Not Shown)	36-33180-18			
25	*Label, "CE Mark" (Not Shown)	36-36842-01			
26	*Label, "DSSI Booklet" (Not Shown)	36-40022-01			
27	*Package Assembly (Not Shown)	37-01072-07			
☞ 28	*Module, Power Harness	54-19789-01			
29	*Bulkhead Assembly, Front	70-23981-01			
30	*Panel Assembly, Gap Filler	70-24071-01			
31	*Chassis Assembly (See IPB Manual EK-440AB-IP)	70-26699-02			
32	*Bezel Assembly, Disk Drive	70-27049-02			
33	*BULKHEAD ASSEMBLY, H3604 CONSOLE	70-27400-01			5
34	*Bezel Assembly, Filler	70-27414-01			
35	*Medallion, VAX 4000-705A	74-40913-26			
36	*Strip, Color	74-40914-01			
37	*Bag, 2 Mil Thick, Poly Reclose (Not Shown)	99-06557-30			
	NOTE 1: This Item Not Shown, Use As Required. NOTE 2: Reference Index For 240V Power Cords.				

THIS PAGE INTENTIONALLY LEFT BLANK

INDICATES FRU LEVEL PARTS.

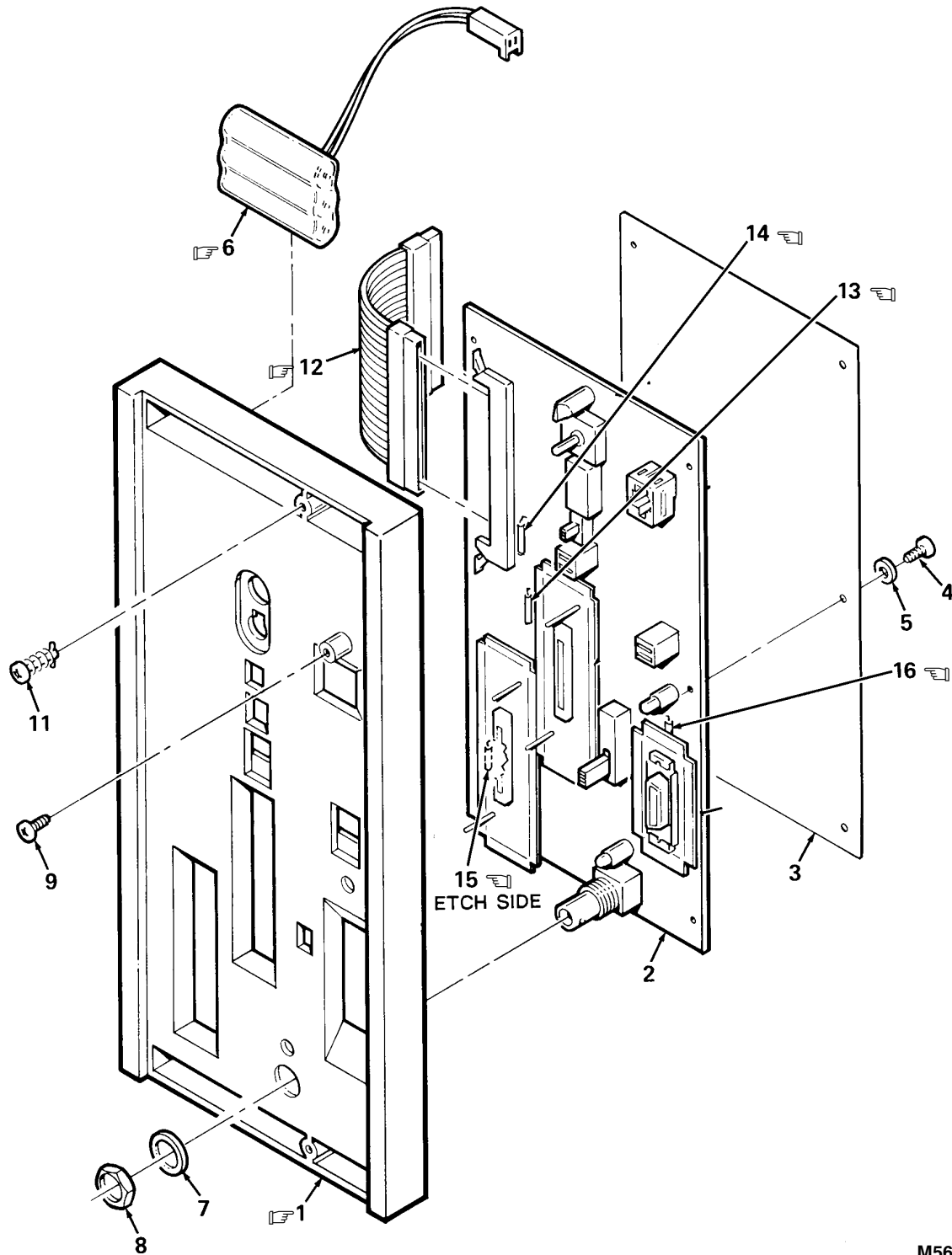

M567A-05-SC

Figure 5. Bulkhead Assembly, H3604 Console

FIG. & ITEM NO.	DESCRIPTION	DIGITAL PART NO. ^c	ECO CUT-IN 70-27400 00002	USED ON CODE	REF FIG NO.
5-	BULKHEAD ASSEMBLY, H3604 CONSOLE	70-27400-01			1, 2, 3, 4
☞ 1	*Cover, Module Assembly	70-27401-01			
2	*Module Assembly, H3604	70-27402-01			
3	*Insulator, Cover Module	74-39280-01			
4	*Screw, Self-Tap Phl Pan Hd No. 6-32 x 3/8	90-09514-01			
5	*Washer, Internal Tooth Lock No. 6	90-09882-00			
☞ 6	*Battery, 3 Cell 3.75V .18ma Nicad	12-19245-01			
7	*Washer, Internal Tooth Lock No. 6 (Bronze)	90-00037-05			
8	*Nut, Hex No. 1/2-28	90-10563-01			
9	*Screw, Self-Tap Phl Pan Hd No. 6-19 x 3/8	90-09800-06			
10	*Package Assembly, Customer Module (Not Shown)	37-00931-11			
11	Fastener, 1/4 Turn (See Note)	12-26948-01			
☞ 12	Cable Assembly, 100 Cond Flat (See Note)	17-02353-01			
☞ 13	Fuse, Pico .500A 125V (F1), ThinWire Ethernet Power (See Note)	12-09159-00			
☞ 14	Fuse, Pico .062A 125V (F2), -12V Logic Power (See Note)	12-09122-00			
☞ 15	Fuse, Pico 2.0A 125V (F3) DSSI Termination Power (Located On Etch Side Of Module.) (See Note)	12-10929-06			
☞ 16	Fuse, Pico 1.5A 125V (F4) Standard Ethernet Power (See Note)	12-10929-08			
	NOTE: These Items Are Not Part Of 70-27400 Assembly And Are Shown For Reference Only.				
					Ω

PART NUMBER/DESCRIPTION INDEX 

THIS PAGE INTENTIONALLY LEFT BLANK

INDEX BY DIGITAL PART NUMBER
VAX 4000 MODELS 5xxA/6xxA/7xxA SYSTEMS

PART NO.	DESCRIPTION	FIG NO.	ITEM NO.
12-09122-00	Fuse, Pico .062A 125V (F2), -12V Logic Power	5	14
12-09159-00	Fuse, Pico .500A 125V (F1), ThinWire Ethernet Power	5	13
12-10929-06	Fuse, Pico 2.0A 125V (F3) DSSI Termination Power	5	15
12-10929-08	Fuse, Pico 1.5A 125V (F4) Standard Ethernet Power	5	16
12-13756-A8	Strap, Ground w/Label	1	3
12-13756-A8	Strap, Ground w/Label	2	3
12-13756-A8	Strap, Ground w/Label	3	3
12-13756-A8	Strap, Ground w/Label	4	3
12-19245-01	Battery, 3 Cell 3.75V .18ma Nicad	5	6
12-25869-01	Tee, BNC Coaxial	1	4
12-25869-01	Tee, BNC Coaxial	2	4
12-25869-01	Tee, BNC Coaxial	3	4
12-25869-01	Tee, BNC Coaxial	4	4
12-26318-01	Connector, BNC Coaxial	1	5
12-26318-01	Connector, BNC Coaxial	2	5
12-26318-01	Connector, BNC Coaxial	3	5
12-26318-01	Connector, BNC Coaxial	4	5
12-26948-01	Fastener, 1/4 Turn	5	11
12-28766-19	Encoder Set, Lens (DSSI Unit ID Plug)	1	6
12-28766-19	Encoder Set, Lens (DSSI Unit ID Plug)	2	6
12-28766-19	Encoder Set, Lens (DSSI Unit ID Plug)	3	6
12-28766-19	Encoder Set, Lens (DSSI Unit ID Plug)	4	6
12-29258-01	Connector, Terminator	1	7
12-29258-01	Connector, Terminator	2	7
12-29258-01	Connector, Terminator	3	7
12-29258-01	Connector, Terminator	4	7
12-33377-01	Cover, 50-Pin IDC Connector	1	8
12-33377-01	Cover, 50-Pin IDC Connector	2	8
12-33377-01	Cover, 50-Pin IDC Connector	3	8
12-33377-01	Cover, 50-Pin IDC Connector	4	8
17-00083-43	Power Cord, 120V 10A (2.5M) (BN20A-2E)	1	9
17-00083-43	Power Cord, 120V 10A (2.5M) (BN20A-2E)	2	9
17-00083-43	Power Cord, 120V 10A (2.5M) (BN20A-2E)	3	9
17-00083-43	Power Cord, 120V 10A (2.5M) (BN20A-2E)	4	9
17-00083-44	Power Cord 240V 10A (2.5M) (BN20B-2E) (US/Japan/Canada) (Not Shown)	1	9
17-00198-11	Power Cord 240V 10A (2.5M) (BN22C-2E) (Australia/New Zealand) (Not Shown)	1	9
17-00199-16	Power Cord 240V 10A (2.5M) (BN22D-2E) (Central Europe) (Not Shown)	1	9
17-00209-13	Power Cord 240V 10A (2.5M) (BN22E-2E) (U.K./Ireland) (Not Shown)	1	9
17-00210-10	Power Cord 240V 10A (2.5M) (BN22F-2E) (Switzerland) (Not Shown)	1	9
17-00310-10	Power Cord 240V 10A (2.5M) (BN22H-2E) (Denmark) (Not Shown)	1	9
17-00364-13	Power Cord 240V 10A (2.5M) (BN22J-2E) (Italy) (Not Shown)	1	9
17-00456-13	Power Cord 240V 10A (2.5M) (BN22K-2E) (India/S. Africa) (Not Shown)	1	9
17-00457-13	Power Cord 240V 10A (2.5M) (BN22L-2E) (Israel) (Not Shown)	1	9

INDEX BY DIGITAL PART NUMBER
VAX 4000 MODELS 5xxA/6xxA/7xxA SYSTEMS

PART NO.	DESCRIPTION	FIG NO.	ITEM NO.
17-01364-02	Cable Assembly, 06 Conductor	1	10
17-01364-02	Cable Assembly, 06 Conductor	2	10
17-01364-02	Cable Assembly, 06 Conductor	3	10
17-01364-02	Cable Assembly, 06 Conductor	4	10
17-02353-01	Cable Assembly, 100 Cond Flat	5	12
36-18940-02	Label, "Switch Marker F/RA70" (Not Shown)	1	11
36-18940-02	Label, "Switch Marker F/RA70" (Not Shown)	2	11
36-18940-02	Label, "Switch Marker F/RA70" (Not Shown)	3	11
36-18940-02	Label, "Switch Marker F/RA70" (Not Shown)	4	11
36-26883-D0	Label, "Module Number, S-Box L4006-AA"	3	12
36-26883-D1	Label, "Module Number, S-Box L4005-AA"	2	12
36-26883-D2	Label, "Module Number, S-Box L4005-BA"	1	12
36-26883-D8	Label, "Module Number, S-Box L4006-BA"	4	12
36-28979-01	Label, "Pre-Installed Software" (Not Shown)	1	13
36-28979-01	Label, "Pre-Installed Software" (Not Shown)	2	13
36-28979-01	Label, "Pre-Installed Software" (Not Shown)	3	13
36-28979-01	Label, "Pre-Installed Software" (Not Shown)	4	13
36-29163-07	Label, "BA2XX Rev" (Rolled)	1	14
36-29163-07	Label, "BA2XX Rev" (Rolled)	2	14
36-29163-07	Label, "BA2XX Rev" (Rolled)	3	14
36-29163-07	Label, "BA2XX Rev" (Rolled)	4	14
36-29164-07	Label, "BA2XX Rev" (Sheeted)	1	15
36-29164-07	Label, "BA2XX Rev" (Sheeted)	2	15
36-29164-07	Label, "BA2XX Rev" (Sheeted)	3	15
36-29164-07	Label, "BA2XX Rev" (Sheeted)	4	15
36-30422-52	Label, "Postcard FTZ" (Not Shown)	1	16
36-30422-52	Label, "Postcard FTZ" (Not Shown)	2	16
36-30422-52	Label, "Postcard FTZ" (Not Shown)	3	16
36-30422-52	Label, "Postcard FTZ" (Not Shown)	4	16
36-32667-23	Label, "BA400 Series KA681" (US)	1	17
36-32667-24	Label, "BA400 Series KA692" (US)	3	17
36-32667-25	Label, "BA400 Series KA691" (US)	2	17
36-32667-26	Label, "BA400 Series KA681" (Canada)	1	18
36-32667-27	Label, "BA400 Series KA692" (Canada)	3	18
36-32667-28	Label, "BA400 Series KA691" (Canada)	2	18
36-32667-29	Label, "BA400 Series KA681" (UK)	1	19
36-32667-30	Label, "BA400 Series KA692" (UK)	3	19
36-32667-31	Label, "BA400 Series KA691" (UK)	2	19
36-32667-35	Label, "BA400 Series KA694" (US)	4	17
36-32667-36	Label, "BA400 Series KA694" (UK)	4	18
36-32667-37	Label, "BA400 Series KA694" (Canada)	4	19
36-32667-41	Label, "BA400 Series KA691" (Canada) (added)	2	20
36-32667-42	Label, "BA400 Series KA691" (US) (added)	2	21
36-32667-43	Label, "BA400 Series KA691" (UK) (added)	2	22
36-32668-01	Label, "BA440 Serial/Model" (US)	1	20
36-32668-01	Label, "BA440 Serial/Model" (US)	2	23
36-32668-01	Label, "BA440 Serial/Model" (US)	3	20
36-32668-01	Label, "BA440 Serial/Model" (US)	4	20
36-32668-02	Label, "BA440 Serial/Model" (UK)	1	21
36-32668-02	Label, "BA440 Serial/Model" (UK)	2	24
36-32668-02	Label, "BA440 Serial/Model" (UK)	3	21
36-32668-02	Label, "BA440 Serial/Model" (UK)	4	21
36-32668-03	Label, "BA440 Serial/Model" (Canada)	1	22

INDEX BY DIGITAL PART NUMBER
VAX 4000 MODELS 5xxA/6xxA/7xxA SYSTEMS

PART NO.	DESCRIPTION	FIG NO.	ITEM NO.
36-32668-03	Label, "BA440 Serial/Model" (Canada)	2	25
36-32668-03	Label, "BA440 Serial/Model" (Canada)	3	22
36-32668-03	Label, "BA440 Serial/Model" (Canada)	4	22
36-33152-15	Label, "Logo/Model VAX 4000-600A"	2	26
36-33152-16	Label, "Logo/Model VAX 4000-500A"	1	23
36-33152-17	Label, "Logo/Model VAX 4000-700A"	3	23
36-33152-20	Label, "Logo/Model VAX 4000-505A" (added)	2	27
36-33152-21	Label, "Logo/Model VAX 4000-705A"	4	23
36-33180-18	Label, "Telecom Approval" (Not Shown)	1	24
36-33180-18	Label, "Telecom Approval" (Not Shown)	2	28
36-33180-18	Label, "Telecom Approval" (Not Shown)	3	24
36-33180-18	Label, "Telecom Approval" (Not Shown)	4	24
36-36842-01	Label, "CE Mark" (Not Shown)	4	25
36-40022-01	Label, "DSSI Booklet" (Not Shown)	1	25
36-40022-01	Label, "DSSI Booklet" (Not Shown)	2	29
36-40022-01	Label, "DSSI Booklet" (Not Shown)	3	25
36-40022-01	Label, "DSSI Booklet" (Not Shown)	4	26
37-00931-11	Package Assembly, Customer Module (Not Shown)	5	10
37-01072-07	Package Assembly (Not Shown)	1	26
37-01072-07	Package Assembly (Not Shown)	2	30
37-01072-07	Package Assembly (Not Shown)	3	26
37-01072-07	Package Assembly (Not Shown)	4	27
54-19789-01	Module, Power Harness	1	27
54-19789-01	Module, Power Harness	2	31
54-19789-01	Module, Power Harness	3	27
54-19789-01	Module, Power Harness	4	28
681QJ-B9	681QJ PEDESTAL SYSTEM	1	N/A
691QJ-B9	Model 691QJ-B9	2	N/A
691QJ-C9	Model 691QJ-C9 (added)	2	N/A
692QJ-B9	692QJ PEDESTAL SYSTEM	3	N/A
694QJ-B9	694QJ PEDESTAL SYSTEM	4	N/A
70-23981-01	Bulkhead Assembly, Front	1	28
70-23981-01	Bulkhead Assembly, Front	2	32
70-23981-01	Bulkhead Assembly, Front	3	28
70-23981-01	Bulkhead Assembly, Front	4	29
70-24071-01	Panel Assembly, Gap Filler	1	29
70-24071-01	Panel Assembly, Gap Filler	2	33
70-24071-01	Panel Assembly, Gap Filler	3	29
70-24071-01	Panel Assembly, Gap Filler	4	30
70-26699-02	Chassis Assembly (See IPB Manual EK-440AB-IP)	1	30
70-26699-02	Chassis Assembly (See IPB Manual EK-440AB-IP)	2	34
70-26699-02	Chassis Assembly (See IPB Manual EK-440AB-IP)	3	30
70-26699-02	Chassis Assembly (See IPB Manual EK-440AB-IP)	4	31
70-27049-02	Bezel Assembly, Disk Drive	1	31
70-27049-02	Bezel Assembly, Disk Drive	2	35
70-27049-02	Bezel Assembly, Disk Drive	3	31
70-27049-02	Bezel Assembly, Disk Drive	4	32
70-27400-01	BULKHEAD ASSEMBLY, H3604 CONSOLE	1	32

INDEX BY DIGITAL PART NUMBER
VAX 4000 MODELS 5xxA/6xxA/7xxA SYSTEMS

PART NO.	DESCRIPTION	FIG NO.	ITEM NO.
70-27400-01	BULKHEAD ASSEMBLY, H3604 CONSOLE	2	36
70-27400-01	BULKHEAD ASSEMBLY, H3604 CONSOLE	3	32
70-27400-01	BULKHEAD ASSEMBLY, H3604 CONSOLE	4	33
70-27400-01	BULKHEAD ASSEMBLY, H3604 CONSOLE	5	N/A
70-27401-01	Cover, Module Assembly	5	1
70-27402-01	Module Assembly, H3604	5	2
70-27414-01	Bezel Assembly, Filler	1	33
70-27414-01	Bezel Assembly, Filler	2	37
70-27414-01	Bezel Assembly, Filler	3	33
70-27414-01	Bezel Assembly, Filler	4	34
74-39280-01	Insulator, Cover Module	5	3
74-40912-25	Medallion, VAX 4000-505A (added)	2	39
74-40913-19	Medallion, VAX 4000-600A	2	38
74-40913-20	Medallion, VAX 4000-500A	1	34
74-40913-21	Medallion, VAX 4000-700A	3	34
74-40913-26	Medallion, VAX 4000-705A	4	35
74-40914-01	Strip, Color	1	35
74-40914-01	Strip, Color	2	40
74-40914-01	Strip, Color	3	35
74-40914-01	Strip, Color	4	36
90-00037-05	Washer, Internal Tooth Lock No. 6 (Bronze)	5	7
90-09514-01	Screw, Self-Tap Phi Pan Hd No. 6-32 x 3/8	5	4
90-09800-06	Screw, Self-Tap Phi Pan Hd No. 6-19 x 3/8	5	9
90-09882-00	Washer, Internal Tooth Lock No. 6	5	5
90-10563-01	Nut, Hex No. 1/2-28	5	8
99-06557-30	Bag, 2 Mil Thick, Poly Reclose (Not Shown)	1	36
99-06557-30	Bag, 2 Mil Thick, Poly Reclose (Not Shown)	2	41
99-06557-30	Bag, 2 Mil Thick, Poly Reclose (Not Shown)	3	36
99-06557-30	Bag, 2 Mil Thick, Poly Reclose (Not Shown)	4	37
L4005-AA	Module, NVAX CPU, 12NS, 512 KB CACHE	2	1
L4005-BA	Module, NVAX CPU, 14NS, 128 KB CACHE	1	1
L4006-AA	Module, NVAX CPU, 10NS, 2 MB CACHE	3	1
L4006-BA	Module, NVAX CPU, 9NS, 2 MB CACHE	4	1
M9047-SA	Kit, Q-bus Grant Continuity	1	2
M9047-SA	Kit, Q-bus Grant Continuity	2	2
M9047-SA	Kit, Q-bus Grant Continuity	3	2
M9047-SA	Kit, Q-bus Grant Continuity	4	2

INDEX BY DIGITAL PART DESCRIPTION
VAX 4000 MODELS 5xxA/6xxA/7xxA SYSTEMS

DESCRIPTION	PART NO.	FIG. NO.	ITEM NO.
692QJ PEDESTAL SYSTEM	692QJ-B9	3	N/A
694QJ PEDESTAL SYSTEM	694QJ-B9	4	N/A
Bag, 2 Mil Thick, Poly Reclose (Not Shown)	99-06557-30	1	36
Bag, 2 Mil Thick, Poly Reclose (Not Shown)	99-06557-30	2	41
Bag, 2 Mil Thick, Poly Reclose (Not Shown)	99-06557-30	3	36
Bag, 2 Mil Thick, Poly Reclose (Not Shown)	99-06557-30	4	37
Battery, 3 Cell 3.75V .18ma Nicad	12-19245-01	5	6
Bezel Assembly, Disk Drive	70-27049-02	1	31
Bezel Assembly, Disk Drive	70-27049-02	2	35
Bezel Assembly, Disk Drive	70-27049-02	3	31
Bezel Assembly, Disk Drive	70-27049-02	4	32
Bezel Assembly, Filler	70-27414-01	1	33
Bezel Assembly, Filler	70-27414-01	2	37
Bezel Assembly, Filler	70-27414-01	3	33
Bezel Assembly, Filler	70-27414-01	4	34
Bulkhead Assembly, Front	70-23981-01	1	28
Bulkhead Assembly, Front	70-23981-01	2	32
Bulkhead Assembly, Front	70-23981-01	3	28
Bulkhead Assembly, Front	70-23981-01	4	29
BULKHEAD ASSEMBLY, H3604 CONSOLE	70-27400-01	1	32
BULKHEAD ASSEMBLY, H3604 CONSOLE	70-27400-01	2	36
BULKHEAD ASSEMBLY, H3604 CONSOLE	70-27400-01	3	32
BULKHEAD ASSEMBLY, H3604 CONSOLE	70-27400-01	4	33
BULKHEAD ASSEMBLY, H3604 CONSOLE	70-27400-01	5	N/A
Cable Assembly, 06 Conductor	17-01364-02	1	10
Cable Assembly, 06 Conductor	17-01364-02	2	10
Cable Assembly, 06 Conductor	17-01364-02	3	10
Cable Assembly, 06 Conductor	17-01364-02	4	10
Cable Assembly, 100 Cond Flat	17-02353-01	5	12
Chassis Assembly (See IPB Manual EK-440AB-IP)	70-26699-02	1	30
Chassis Assembly (See IPB Manual EK-440AB-IP)	70-26699-02	2	34
Chassis Assembly (See IPB Manual EK-440AB-IP)	70-26699-02	3	30
Chassis Assembly (See IPB Manual EK-440AB-IP)	70-26699-02	4	31
Connector, BNC Coaxial	12-26318-01	1	5
Connector, BNC Coaxial	12-26318-01	2	5
Connector, BNC Coaxial	12-26318-01	3	5
Connector, BNC Coaxial	12-26318-01	4	5
Connector, Terminator	12-29258-01	1	7
Connector, Terminator	12-29258-01	2	7
Connector, Terminator	12-29258-01	3	7
Connector, Terminator	12-29258-01	4	7
Cover, 50-Pin IDC Connector	12-33377-01	1	8
Cover, 50-Pin IDC Connector	12-33377-01	2	8
Cover, 50-Pin IDC Connector	12-33377-01	3	8
Cover, 50-Pin IDC Connector	12-33377-01	4	8
Cover, Module Assembly	70-27401-01	5	1
Encoder Set, Lens (DSSI Unit ID Plug)	12-28766-19	1	6
Encoder Set, Lens (DSSI Unit ID Plug)	12-28766-19	2	6
Encoder Set, Lens (DSSI Unit ID Plug)	12-28766-19	3	6
Encoder Set, Lens (DSSI Unit ID Plug)	12-28766-19	4	6

INDEX BY DIGITAL PART DESCRIPTION
VAX 4000 MODELS 5xxA/6xxA/7xxA SYSTEMS

DESCRIPTION	PART NO.	FIG. NO.	ITEM NO.
Fastener, 1/4 Turn	12-26948-01	5	11
Fuse, Pico .062A 125V (F2), -12V Logic Power	12-09122-00	5	14
Fuse, Pico .500A 125V (F1), ThinWire Ethernet Power	12-09159-00	5	13
Fuse, Pico 1.5A 125V (F4) Standard Ethernet Power	12-10929-08	5	16
Fuse, Pico 2.0A 125V (F3) DSSI Termination Power	12-10929-06	5	15
Insulator, Cover Module	74-39280-01	5	3
Kit, Q-bus Grant Continuity	M9047-SA	1	2
Kit, Q-bus Grant Continuity	M9047-SA	2	2
Kit, Q-bus Grant Continuity	M9047-SA	3	2
Kit, Q-bus Grant Continuity	M9047-SA	4	2
Label, "BA2XX Rev" (Rolled)	36-29163-07	1	14
Label, "BA2XX Rev" (Rolled)	36-29163-07	2	14
Label, "BA2XX Rev" (Rolled)	36-29163-07	3	14
Label, "BA2XX Rev" (Rolled)	36-29163-07	4	14
Label, "BA2XX Rev" (Sheeted)	36-29164-07	1	15
Label, "BA2XX Rev" (Sheeted)	36-29164-07	2	15
Label, "BA2XX Rev" (Sheeted)	36-29164-07	3	15
Label, "BA2XX Rev" (Sheeted)	36-29164-07	4	15
Label, "BA400 Series KA681" (Canada)	36-32667-26	1	18
Label, "BA400 Series KA681" (UK)	36-32667-29	1	19
Label, "BA400 Series KA681" (US)	36-32667-23	1	17
Label, "BA400 Series KA691" (Canada)	36-32667-28	2	18
Label, "BA400 Series KA691" (Canada) (added)	36-32667-41	2	20
Label, "BA400 Series KA691" (UK)	36-32667-31	2	19
Label, "BA400 Series KA691" (UK) (added)	36-32667-43	2	22
Label, "BA400 Series KA691" (US)	36-32667-25	2	17
Label, "BA400 Series KA691" (US) (added)	36-32667-42	2	21
Label, "BA400 Series KA692" (Canada)	36-32667-27	3	18
Label, "BA400 Series KA692" (UK)	36-32667-30	3	19
Label, "BA400 Series KA692" (US)	36-32667-24	3	17
Label, "BA400 Series KA694" (Canada)	36-32667-37	4	19
Label, "BA400 Series KA694" (UK)	36-32667-36	4	18
Label, "BA400 Series KA694" (US)	36-32667-35	4	17
Label, "BA440 Serial/Model" (Canada)	36-32668-03	1	22
Label, "BA440 Serial/Model" (Canada)	36-32668-03	2	25
Label, "BA440 Serial/Model" (Canada)	36-32668-03	3	22
Label, "BA440 Serial/Model" (Canada)	36-32668-03	4	22
Label, "BA440 Serial/Model" (UK)	36-32668-02	1	21
Label, "BA440 Serial/Model" (UK)	36-32668-02	2	24
Label, "BA440 Serial/Model" (UK)	36-32668-02	3	21
Label, "BA440 Serial/Model" (UK)	36-32668-02	4	21
Label, "BA440 Serial/Model" (US)	36-32668-01	1	20
Label, "BA440 Serial/Model" (US)	36-32668-01	2	23
Label, "BA440 Serial/Model" (US)	36-32668-01	3	20
Label, "BA440 Serial/Model" (US)	36-32668-01	4	20
Label, "CE Mark" (Not Shown)	36-36842-01	4	25
Label, "DSSI Booklet" (Not Shown)	36-40022-01	1	25
Label, "DSSI Booklet" (Not Shown)	36-40022-01	2	29
Label, "DSSI Booklet" (Not Shown)	36-40022-01	3	25
Label, "DSSI Booklet" (Not Shown)	36-40022-01	4	26
Label, "Logo/Model VAX 4000-500A"	36-33152-16	1	23
Label, "Logo/Model VAX 4000-505A" (added)	36-33152-20	2	27

INDEX BY DIGITAL PART DESCRIPTION
VAX 4000 MODELS 5xxA/6xxA/7xxA SYSTEMS

DESCRIPTION	PART NO.	FIG. NO.	ITEM NO.
Label, "Logo/Model VAX 4000-600A"	36-33152-15	2	26
Label, "Logo/Model VAX 4000-700A"	36-33152-17	3	23
Label, "Logo/Model VAX 4000-705A"	36-33152-21	4	23
Label, "Module Number, S-Box L4005-AA"	36-26883-D1	2	12
Label, "Module Number, S-Box L4005-BA"	36-26883-D2	1	12
Label, "Module Number, S-Box L4006-AA"	36-26883-D0	3	12
Label, "Module Number, S-Box L4006-BA"	36-26883-D8	4	12
Label, "Postcard FTZ" (Not Shown)	36-30422-52	1	16
Label, "Postcard FTZ" (Not Shown)	36-30422-52	2	16
Label, "Postcard FTZ" (Not Shown)	36-30422-52	3	16
Label, "Postcard FTZ" (Not Shown)	36-30422-52	4	16
Label, "Pre-Installed Software" (Not Shown)	36-28979-01	1	13
Label, "Pre-Installed Software" (Not Shown)	36-28979-01	2	13
Label, "Pre-Installed Software" (Not Shown)	36-28979-01	3	13
Label, "Pre-Installed Software" (Not Shown)	36-28979-01	4	13
Label, "Switch Marker F/RA70" (Not Shown)	36-18940-02	1	11
Label, "Switch Marker F/RA70" (Not Shown)	36-18940-02	2	11
Label, "Switch Marker F/RA70" (Not Shown)	36-18940-02	3	11
Label, "Switch Marker F/RA70" (Not Shown)	36-18940-02	4	11
Label, "Telecom Approval" (Not Shown)	36-33180-18	1	24
Label, "Telecom Approval" (Not Shown)	36-33180-18	2	28
Label, "Telecom Approval" (Not Shown)	36-33180-18	3	24
Label, "Telecom Approval" (Not Shown)	36-33180-18	4	24
Medallion, VAX 4000-500A	74-40913-20	1	34
Medallion, VAX 4000-505A (added)	74-40912-25	2	39
Medallion, VAX 4000-600A	74-40913-19	2	38
Medallion, VAX 4000-700A	74-40913-21	3	34
Medallion, VAX 4000-705A	74-40913-26	4	35
Model 691QJ-B9	691QJ-B9	2	N/A
Model 691QJ-C9 (added)	691QJ-C9	2	N/A
Module Assembly, H3604	70-27402-01	5	2
Module, NVAX CPU, 10NS, 2 MB CACHE	L4006-AA	3	1
Module, NVAX CPU, 12NS, 512 KB CACHE	L4005-AA	2	1
Module, NVAX CPU, 14NS, 128 KB CACHE	L4005-BA	1	1
Module, NVAX CPU, 9NS, 2 MB CACHE	L4006-BA	4	1
Module, Power Harness	54-19789-01	1	27
Module, Power Harness	54-19789-01	2	31
Module, Power Harness	54-19789-01	3	27
Module, Power Harness	54-19789-01	4	28
Nut, Hex No. 1/2-28	90-10563-01	5	8
Package Assembly (Not Shown)	37-01072-07	1	26
Package Assembly (Not Shown)	37-01072-07	2	30
Package Assembly (Not Shown)	37-01072-07	3	26
Package Assembly (Not Shown)	37-01072-07	4	27
Package Assembly, Customer Module (Not Shown)	37-00931-11	5	10
Panel Assembly, Gap Filler	70-24071-01	1	29
Panel Assembly, Gap Filler	70-24071-01	2	33
Panel Assembly, Gap Filler	70-24071-01	3	29
Panel Assembly, Gap Filler	70-24071-01	4	30
PEDESTAL SYSTEM	681QJ-B9	1	N/A

INDEX BY DIGITAL PART DESCRIPTION
VAX 4000 MODELS 5xxA/6xxA/7xxA SYSTEMS

DESCRIPTION	PART NO.	FIG. NO.	ITEM NO.
Power Cord, 120V 10A (2.5M) (BN20A-2E)	17-00083-43	1	9
Power Cord, 120V 10A (2.5M) (BN20A-2E)	17-00083-43	2	9
Power Cord, 120V 10A (2.5M) (BN20A-2E)	17-00083-43	3	9
Power Cord, 120V 10A (2.5M) (BN20A-2E)	17-00083-43	4	9
Power Cord 240V 10A (2.5M) (BN20B-2E) (US/Japan/Canada) (Not Shown)	17-00083-44	1	9
Power Cord 240V 10A (2.5M) (BN22C-2E) (Australia/New Zealand) (Not Shown)	17-00198-11	1	9
Power Cord 240V 10A (2.5M) (BN22D-2E) (Central Europe) (Not Shown)	17-00199-16	1	9
Power Cord 240V 10A (2.5M) (BN22E-2E) (U.K./Ireland) (Not Shown)	17-00209-13	1	9
Power Cord 240V 10A (2.5M) (BN22F-2E) (Switzerland) (Not Shown)	17-00210-10	1	9
Power Cord 240V 10A (2.5M) (BN22H-2E) (Denmark) (Not Shown)	17-00310-10	1	9
Power Cord 240V 10A (2.5M) (BN22J-2E) (Italy) (Not Shown)	17-00364-13	1	9
Power Cord 240V 10A (2.5M) (BN22K-2E) (India/S. Africa) (Not Shown)	17-00456-13	1	9
Power Cord 240V 10A (2.5M) (BN22L-2E) (Israel) (Not Shown)	17-00457-13	1	9
Screw, Self-Tap Phi Pan Hd No. 6-19 x 3/8	90-09800-06	5	9
Screw, Self-Tap Phi Pan Hd No. 6-32 x 3/8	90-09514-01	5	4
Strap, Ground w/Label	12-13756-A8	1	3
Strap, Ground w/Label	12-13756-A8	2	3
Strap, Ground w/Label	12-13756-A8	3	3
Strap, Ground w/Label	12-13756-A8	4	3
Strip, Color	74-40914-01	1	35
Strip, Color	74-40914-01	2	40
Strip, Color	74-40914-01	3	35
Strip, Color	74-40914-01	4	36
Tee, BNC Coaxial	12-25869-01	1	4
Tee, BNC Coaxial	12-25869-01	2	4
Tee, BNC Coaxial	12-25869-01	3	4
Tee, BNC Coaxial	12-25869-01	4	4
Washer, Internal Tooth Lock No. 6	90-09882-00	5	5
Washer, Internal Tooth Lock No. 6 (Bronze)	90-00037-05	5	7