

**KT11-C memory  
management unit  
maintenance manual**

1st Edition, April 1972  
2nd Printing (Rev) July 1972  
3rd Printing, November 1972  
4th Printing, February 1973  
5th Printing, July 1973  
6th Printing (Rev) October 1973  
7th Printing, January 1974

Copyright © 1972, 1973, 1974 by Digital Equipment Corporation

The material in this manual is for informational purposes and is subject to change without notice.

Digital Equipment Corporation assumes no responsibility for any errors which may appear in this manual.

Printed in U.S.A.

The following are trademarks of Digital Equipment Corporation, Maynard, Massachusetts:

|           |              |
|-----------|--------------|
| DEC       | PDP          |
| FLIP CHIP | FOCAL        |
| DIGITAL   | COMPUTER LAB |
| UNIBUS    |              |

## CONTENTS

|  | Page |
|--|------|
| <b>CHAPTER 1 GENERAL DESCRIPTION</b>             |      |
| 1.1 Purpose of Option                            | 1-1  |
| 1.2 Prerequisite                                 | 1-1  |
| 1.3 Features                                     | 1-1  |
| 1.3.1 Memory Protection                          | 1-1  |
| 1.3.2 Relocation/Virtual Memory                  | 1-3  |
| 1.3.3 Memory Expansion                           | 1-3  |
| 1.3.4 Variable Size Pages                        | 1-3  |
| 1.3.5 Page State Information                     | 1-3  |
| 1.3.6 Instruction/Data Spaces                    | 1-4  |
| 1.3.7 Kernel/Supervisor/User Spaces              | 1-4  |
| 1.3.8 Program vs Stack Pages                     | 1-4  |
| 1.3.9 Fault Recovery                             | 1-4  |
| 1.3.10 Statistical Traps                         | 1-4  |
| 1.4 KT11-C Memory Management Unit Specifications | 1-4  |
| <b>CHAPTER 2 OPERATION AND PROGRAMMING</b>       |      |
| 2.1 Basic KT11-C Mechanisms                      | 2-1  |
| 2.1.1 Address Relocation Mechanism               | 2-1  |
| 2.1.2 Memory Protection Mechanisms               | 2-4  |
| 2.1.2.1 Non-Resident/Read-Only Protection        | 2-4  |
| 2.1.2.2 Execute-Only Protection                  | 2-4  |
| 2.1.2.3 Multiple Address Space Protection        | 2-5  |
| 2.1.3 Memory Management Statistics Mechanism     | 2-5  |
| 2.1.4 Trap/Abort Mechanism                       | 2-6  |
| 2.2 PAR/PDR Registers                            | 2-6  |
| 2.2.1 Page Address Registers (PAR)               | 2-7  |
| 2.2.2 Page Descriptor Registers (PDR)            | 2-8  |
| 2.2.2.1 Access Control Field (ACF)               | 2-9  |
| 2.2.2.2 Expansion Direction (ED)                 | 2-9  |
| 2.2.2.3 Written Into (W)                         | 2-10 |
| 2.2.2.4 Attention (A)                            | 2-12 |
| 2.2.2.5 Page Length Field (PLF)                  | 2-12 |
| 2.3 Memory Management Status Registers           | 2-13 |
| 2.3.1 Status Register 0 (SR0)                    | 2-14 |
| 2.3.1.1 Abort-Nonresident                        | 2-14 |
| 2.3.1.2 Abort-Page Length                        | 2-14 |
| 2.3.1.3 Abort-Read Only                          | 2-14 |
| 2.3.1.4 Trap-Memory Management                   | 2-14 |
| 2.3.1.5 Bit 11                                   | 2-14 |
| 2.3.1.6 Enable Memory Management                 | 2-15 |
| 2.3.1.7 Maintenance/Destination Mode             | 2-15 |
| 2.3.1.8 Instruction Completed                    | 2-15 |

## CONTENTS (Cont)

|          | Page   |      |
|----------|--|------|
| 2.3.1.9  | Abort Recovery Information                                 | 2-15 |
| 2.3.1.10 | Enable KT11-C  | 2-15 |
| 2.3.2    | Status Register 1 (SR1)                                    | 2-15 |
| 2.3.3    | Status Register 2 (SR2)                                    | 2-16 |
| 2.3.4    | Status Register 3 (SR3)                                    | 2-17 |
| 2.4      | KT11-C Operation   | 2-17 |
| 2.4.1    | Console Operations   | 2-17 |
| 2.4.1.1  | Single Step Mode   | 2-17 |
| 2.4.1.2  | Address Display  | 2-17 |
| 2.4.1.3  | Stepping Over 32K-Word Boundaries                          | 2-17 |
| 2.4.2    | Physical Address Determination                             | 2-17 |
| 2.4.3    | Protection Without Relocation                              | 2-18 |
| 2.4.4    | Communication Between User/Supervisor/Kernel Address Space | 2-19 |
| 2.4.4.1  | Overlapping Physical Addresses                             | 2-19 |
| 2.4.4.2  | MFPI and MTPD Instructions Use                             | 2-19 |
| 2.4.4.3  | Control Information  | 2-20 |
| 2.4.5    | Statistical Aids Use                                       | 2-20 |
| 2.4.6    | I and D Space Use  | 2-21 |
| 2.4.7    | I/O Operations   | 2-22 |
| 2.4.7.1  | Kernel Mode Protection                                     | 2-22 |
| 2.4.7.2  | Avoiding I/O Lockout                                       | 2-22 |
| 2.4.8    | Processor Status Word                                      | 2-22 |
| 2.4.8.1  | Explicit References to PS                                  | 2-22 |
| 2.4.8.2  | Implicit Modification of the PS                            | 2-23 |
| 2.4.9    | Non-Recoverable Aborts                                     | 2-23 |
| 2.4.10   | Page Fault Recovery  | 2-23 |
| 2.4.10.1 | Definitions  | 2-23 |
| 2.4.10.2 | Program Example  | 2-25 |
| 2.4.11   | Fatal System Errors  | 2-28 |

### CHAPTER 3 LOGIC DESCRIPTION

|         |                                 |     |
|---------|---------------------------------|-----|
| 3.1     | PDP-11/45 System Interface      | 3-1 |
| 3.2     | KT11-C Organization             | 3-2 |
| 3.2.1   | System Address Path (SAP)       | 3-2 |
| 3.2.2   | Status and Control Logic        | 3-2 |
| 3.3     | PAR/PDR Registers               | 3-2 |
| 3.3.1   | Page Address Registers (PAR)    | 3-4 |
| 3.3.1.1 | Selection                       | 3-4 |
| 3.3.1.2 | Addressing                      | 3-4 |
| 3.3.1.3 | Writing Into a PAR              | 3-5 |
| 3.3.1.4 | Reading From a PAR              | 3-5 |
| 3.3.2   | Page Descriptor Registers (PDR) | 3-5 |
| 3.3.2.1 | Selection                       | 3-5 |

## CONTENTS (Cont)

|          |                                     | Page |
|----------|-------------------------------------|------|
| 3.3.2.2  | Addressing                          | 3-5  |
| 3.3.2.3  | Writing Into a PDR                  | 3-6  |
| 3.3.2.4  | Setting A or W Bits                 | 3-6  |
| 3.3.2.5  | Clearing A or W Bits                | 3-6  |
| 3.3.2.6  | Reading From a PDR                  | 3-6  |
| 3.4      | Relocation Logic                    | 3-6  |
| 3.4.1    | Address Inverters/Buffers           | 3-6  |
| 3.4.2    | 12-Bit Adder                        | 3-6  |
| 3.4.3    | Relocation Multiplexer              | 3-7  |
| 3.5      | Console Address Display and Control | 3-7  |
| 3.5.1    | ADDRESS Display                     | 3-7  |
| 3.5.2    | Console Mode Control                | 3-7  |
| 3.6      | Abort and Trap Decode               | 3-7  |
| 3.6.1    | Abort Control Logic                 | 3-9  |
| 3.6.1.1  | Non-Resident (NR) Page Fault        | 3-9  |
| 3.6.1.2  | Resident Read-Only (RRO) Fault      | 3-9  |
| 3.6.1.3  | Page Length Fault                   | 3-9  |
| 3.6.2    | Internal Register Inhibit           | 3-9  |
| 3.6.3    | Memory Management Trap Decode       | 3-10 |
| 3.7      | PAR/PDR Read Multiplexers           | 3-10 |
| 3.8      | Unibus Address Drivers              | 3-10 |
| 3.9      | Status Register 3 (SR3)             | 3-10 |
| 3.10     | KT11-C ROM and Decode               | 3-10 |
| 3.10.1   | ROM Organization                    | 3-11 |
| 3.10.2   | ROM OUT (4:1) Decoders              | 3-12 |
| 3.10.2.1 | RESTORE PS                          | 3-13 |
| 3.10.2.2 | SSRA JSR.30 (ROM (3:1) = 5)         | 3-13 |
| 3.10.2.3 | BRK.30 (ROM (3:1) = 4)              | 3-13 |
| 3.10.2.4 | AUTO DEC (ROM (3:1) = 3)            | 3-13 |
| 3.10.2.5 | ONE CHANGED (ROM (3:1) = 2 or 3)    | 3-13 |
| 3.10.2.6 | DST                                 | 3-14 |
| 3.10.3   | Kernel Space Control                | 3-14 |
| 3.10.4   | Supervisor Space Control            | 3-14 |
| 3.10.5   | User Space Control                  | 3-14 |
| 3.10.6   | I Space Control                     | 3-14 |
| 3.11     | Status Register 0 (SR0)             | 3-15 |
| 3.11.1   | Abort Flags SR0 (15:13)             | 3-15 |
| 3.11.2   | Memory Management Trap (SR0 Bit 12) | 3-16 |
| 3.11.2.1 | Enable Management Traps             | 3-16 |
| 3.11.2.2 | Pre-Management Trap                 | 3-16 |
| 3.11.2.3 | Memory Management Hold              | 3-16 |
| 3.11.2.4 | Writing Into SR0 Bit 12             | 3-19 |
| 3.11.3   | Trap Flag (SR0 Bit 11)              | 3-19 |
| 3.11.4   | DST MODE (SR0 Bit 08)               | 3-19 |

## CONTENTS (Cont)

|   | <b>Page</b>                               |
|---|---|
| 3.11.5  | INSTR COMP (SR0 Bit 07) 3-19              |
| 3.11.6  | SR0 Mode Field (SR0 Bits <06:05>) 3-19    |
| 3.11.7  | Address Space – I/D (SR0 Bit 04) 3-20     |
| 3.11.8  | Page Number (SR0 Bits <03:01>) 3-20       |
| 3.11.9  | KT11-C Relocating (SW0 Bit 00) 3-20       |
| 3.12  | Status Register 1 (SR1) 3-20              |
| 3.12.1  | General Register Address 3-20             |
| 3.12.2  | Autoincrement/Autodecrement 3-21          |
| 3.12.3  | Examples of SR1 Loading 3-21              |
| 3.13  | Status Register 2 (SR2) 3-22              |
| 3.14  | Internal Data Bus Multiplexers 3-22       |
| 3.15  | KT11-C Memory Management Timing 3-23      |
| 3.15.1  | Event Times Related to Memory Cycles 3-23 |
| 3.15.2  | Address Relocation Timing 3-23            |
| 3.15.3  | Internal Register Access Timing 3-23      |
| 3.16  | Internal Register Control 3-23            |
| 3.16.1  | PAR/PDR Decode and Control 3-28           |
| 3.16.2  | SSR Decode and Control 3-28               |
| 3.16.2.1  | SSR REG 3-28                              |
| 3.16.2.2  | INT SR3 3-28                              |
| 3.16.3  | Internal Register Fast Decode 3-28        |
| <br><b>CHAPTER 4 INSTALLATION AND MAINTENANCE</b> |   |
| 4.1   | Installation 4-1                          |
| 4.2   | Maintenance 4-1                           |
| 4.2.1   | Diagnostic Programs 4-1                   |
| 4.2.2   | Troubleshooting Test Procedures 4-1       |
| 4.2.3   | Repair Procedures 4-1                     |
| <br><b>APPENDIX A GLOSSARY</b>                    |   |
| <br><b>APPENDIX B REFERENCE LITERATURE</b>        |   |
| <br><b>B-1</b>                                    |   |

## ILLUSTRATIONS

| <b>Figure No.</b> | <b>Title</b>  | <b>Page</b> |
|-------------------|---|-------------|
| 1-1               | System Block Diagram  | 1-2         |
| 2-1               | Basic KT11-C Relocation Mechanism                               | 2-2         |
| 2-2               | Relocation of a 32K-Word Program into 124K-Word Physical Memory | 2-3         |
| 2-3               | Construction of an 18-Bit Physical Address                      | 2-3         |

## ILLUSTRATIONS (Cont)

| Figure No. | Title  | Page |
|------------|--|------|
| 2-4        | Comparison of Non-Reentrant and Reentrant Program Space Requirements | 2-4  |
| 2-5        | KT11-C Memory Management Unit PAR/PDR Registers                      | 2-6  |
| 2-6        | Page Address Register (PAR) Format                                   | 2-7  |
| 2-7        | Page Descriptor Register (PDR) Format                                | 2-9  |
| 2-8        | Example of an Upward Expandable Page                                 | 2-10 |
| 2-9        | Example of a Downward Expandable Page                                | 2-11 |
| 2-10       | Format of Status Register 0 (SR0)                                    | 2-13 |
| 2-11       | Format of Status Register 1 (SR1)                                    | 2-16 |
| 2-12       | Format of Status Register 2 (SR2)                                    | 2-16 |
| 2-13       | Format of Status Register 3 (SR3)                                    | 2-17 |
| 2-14       | Flow Chart for a Page Fault Recovery Routine                         | 2-24 |
| 3-1        | KT11-C System Hardware Interface                                     | 3-1  |
| 3-2        | KT11-C Memory Management Unit, Block Diagram                         | 3-3  |
| 3-3        | Sources of ADDRESS Display, Simplified Diagram                       | 3-8  |
| 3-4        | KT11-C/KB11-A Abort Control Sequence                                 | 3-17 |
| 3-5        | KT11-C/KB11-A Trap Control Sequence                                  | 3-18 |
| 3-6        | Examples of SR1 Loading  | 3-22 |
| 3-7        | KT11-C Timing Diagram  | 3-24 |
| 3-8        | Address Relocation Sequence, Simplified Diagram                      | 3-26 |
| 3-9        | Internal Register Access Sequence, Simplified Diagram                | 3-27 |

## TABLES

| Table No. | Title  | Page |
|-----------|--|------|
| 1-1       | Abridged Specifications Summary                  | 1-5  |
| 2-1       | PAR/PDR Address Assignments                      | 2-8  |
| 2-2       | Access Control Field Keys                        | 2-9  |
| 2-3       | Address Display Select Switch                    | 2-18 |
| 2-4       | Relating Virtual Address to PAR/PDR Set          | 2-18 |
| 2-5       | Mnemonic Definitions                             | 2-25 |
| 3-1       | Address Bit Source                               | 3-4  |
| 3-2       | Address Display Sources                          | 3-8  |
| 3-3       | ROM Output Decoding                              | 3-11 |
| 3-4       | Truth Table for Constant Multiplexer Outputs     | 3-21 |
| 3-5       | How KT11-C Events Relate to KB11-A Memory Cycles | 3-25 |



# INTRODUCTION

The KT11-C Memory Management Unit is a hardware option designed for use with the PDP-11/45 Programmed Data Processor. This manual:

- Provides an understanding of the KT11-C in a PDP-11/45 system.
- Explains the KT11-C hardware and how it can be used to develop the memory management module of a software operating system.
- Describes the KT11-C logic in sufficient detail to enable maintenance personnel to perform on-site troubleshooting and repair.

The KT11-C interacts with the KB11-A Central Processor Unit and operating system software to achieve PDP-11/45 system memory management objectives. For this reason, a description of memory management system objectives and programming information is included in this manual.

**Chapter 1** introduces the purpose and features of the memory management unit.

**Chapter 2** describes the implementation of the features from a programming level. It also describes the internal registers and their application, hints, and exceptions of interest to programmers.

**Chapter 3** provides a detailed description of the logic. The content and organization of this chapter are based on the block schematics contained in Volume 2 of this manual.

**Chapter 4** references the installation and maintenance procedures provided in the *PDP-11/45 System Maintenance Manual* (DEC-11-H45A-D). There are no specific KT11-C installation or maintenance procedures in this manual.

**Appendix A** is a glossary of terms.

**Appendix B** is a bibliography of references on operating systems memory management.

The Index is an alphabetical list of subjects with the page number where the subject appears.

Detailed descriptions of the processor, console, Unibus, Fastbus, and memory logic that interface with the memory management unit are provided in the following related documents.

|  |                |
|--|----------------|
| PDP-11/45 System Maintenance Manual                  | DEC-11-H45B-D  |
| KB11-A Central Processor Unit Maintenance Manual     | DEC-11-HKBB-D  |
| MS11 Semiconductor Memory Systems Maintenance Manual | DEC-11-HMSB-D  |
| PDP-11/45 Processor Handbook                         | 112.01071.1876 |
| PDP-11 Unibus Interface Manual (2nd Edition)         | DEC-11-HIAB-D  |

# CHAPTER 1

## GENERAL DESCRIPTION

This chapter describes the features of the KT11-C in “systems” terms and also includes a specification summary.

### 1.1 PURPOSE OF OPTION

The KT11-C Memory Management Unit intercepts addresses generated by the processor (before they reach memory), processes the addresses received, and then transmits the processed addresses to memory. Address processing is the main function of the memory management option. This processing or modification of addresses is called *relocation*. Processing is termed relocation because it consists of adding a fixed constant to every processor address. The location of the KT11-C option in the PDP-11/45 system is shown in Figure 1-1.

The terms and definitions contained in Appendix A and referred to in this manual are consistent with industry-accepted definitions.

### 1.2 PREREQUISITE

The KT11-C Memory Management Unit is required on all systems with more than 28K of main memory (bipolar, MOS, and core). The option should also be considered for systems with real-time and timesharing applications as well as any system that runs user programs under a control or monitor program. For a narrative description of the PDP-11/45 system’s ability to support timesharing and real-time operating systems, refer to Paragraph 4.3 in the *KB11-A Central Processor Maintenance Manual*.

### 1.3 FEATURES

The KT11-C features outlined below are described in detail in this manual. The KT11-C option:

- expands the basic 28K-word memory capability to 124K words.
- provides dynamic read-only and execute-only memory protection.
- provides up to 16 relocatable, variable length pages per processor mode.
- ensures protection of operating system and user programs by implementing separate address spaces for the Kernel, Supervisor, and User modes.
- provides additional advanced memory management capabilities.

#### 1.3.1 Memory Protection

The memory management unit enables the user to protect one section of memory from access or destruction by programs located in another section. The KT11-C divides the memory into sections called *pages*. Each individual page has a protection or access key associated with it that restricts access to the page. With the memory management unit, a page can be keyed *non-resident* (memory neither readable nor writable), *read-only* (no write

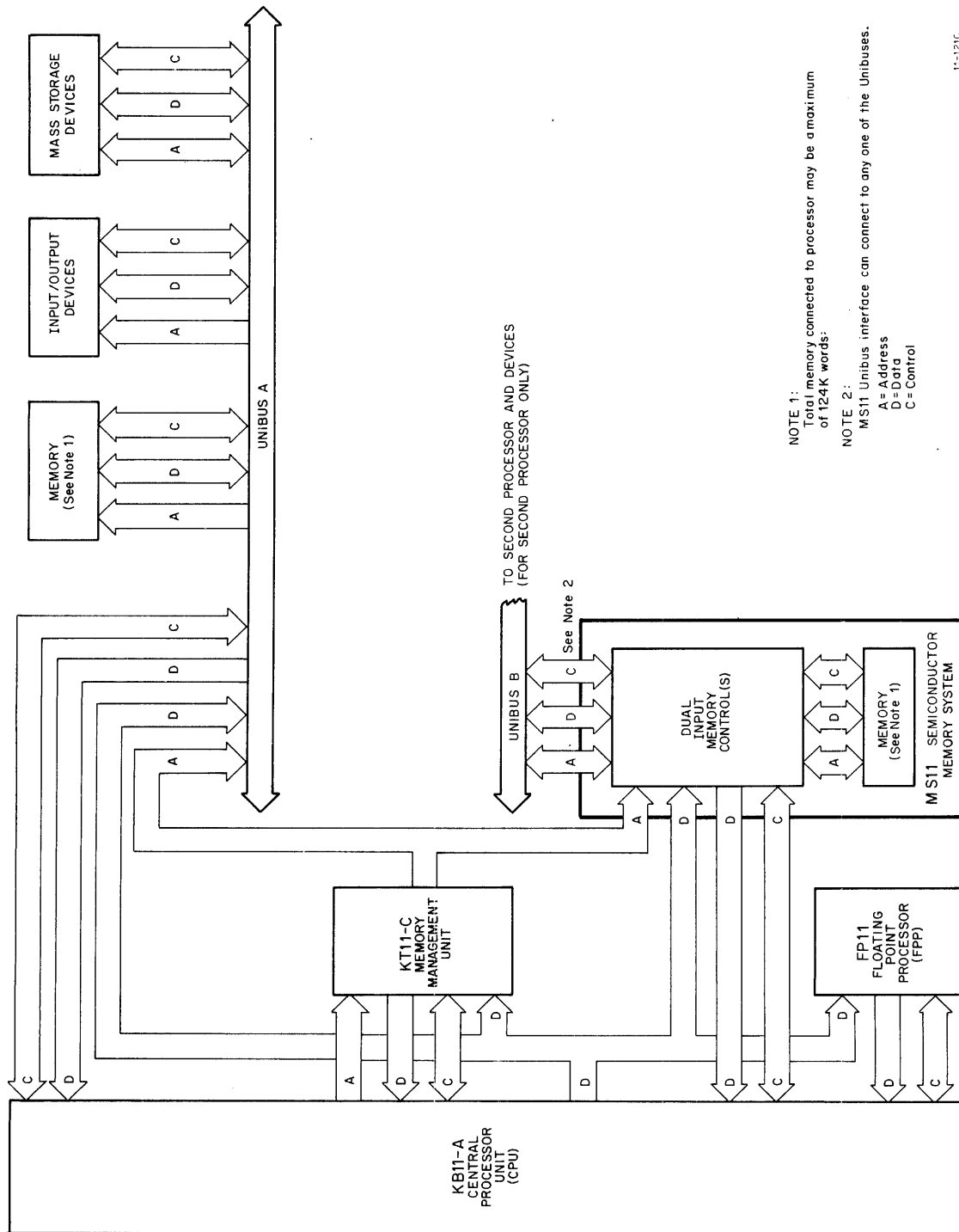

11-121C

Figure 1-1 System Block Diagram

or store operations to memory), or *execute-only* (only instructions, immediate operands, absolute addresses, and index words can be accessed from memory). These three types of protection in association with other features of the KT11-C enable the user to develop an ultrareliable computer operating system. With the non-resident key, memory not specifically assigned to a program can be made unavailable to it. As a result, program errors are unable to execute unwanted material left over from some other process, and they cannot modify any other programs. The read-only key protects data bases and pure code sections from malicious or accidental destruction while allowing them to be accessed. With User mode programs, the execute-only feature allows proprietary codes to be executed but not copied.

### 1.3.2 Relocation/Virtual Memory

Often it is desirable to load a program into one set of locations in memory and then execute it as if it were located in another set of locations, e.g., when several user programs are simultaneously stored in memory. When any one program is running, it must be accessed by the processor as if it were located in the set of addresses beginning at 0. This process is called *relocation*. When the processor accesses program location 0, an address base (base address) is added to the address; thus, the relocated 0 location of the program is accessed. This same base address is added to all references while the program is running. A different base address is used for each of the other programs in memory.

Processor-generated addresses differ from those that address memory; thus the processor addresses are sometimes termed *virtual addresses*, and the memory addresses termed *physical addresses*. The memory management option specifies relocation on a page basis, which allows a large program to be loaded into discontinuous pages in memory. This ability eliminates the need to shuffle programs to accommodate a new one. It also minimizes unusable memory fragments, allowing more users to be loaded in a specific memory size.

In timesharing systems with swapping, relocation eliminates the need to “relink” a program when it is swapped into a different memory location.

### 1.3.3 Memory Expansion

The relocated address is an 18-bit address that can access 128K words of address space, enabling the memory management option to expand the accessible address space of a program from 32K to 128K. Expanding the address space permits larger programs to be handled and allows several programs to occupy the memory at once. In addition, the KT11-C option provides for expansion into multiprocessor systems where typically the total memory exceeds 28K words.

### 1.3.4 Variable Size Pages

A program and its data may occupy as many as 16 pages in the memory. The size of each page varies and each page can be any multiple of 32 words up to 4096 words in length. These features enable small areas in memory to be protected, i.e., stacks, buffers, etc., and also enable the last page of a program exceeding 4K words to be of adequate length to protect and relocate the remainder of the program. As a result, the page fragmentation problem inherent with fixed length pages is eliminated. With the relocation mechanism, the base address of each page can be any multiple of 32 words in the 128K physical address space, thus ensuring compacted code. Finally, the variable page size enables pages to be dynamically changed at run time.

### 1.3.5 Page State Information

The memory management unit provides two bits of active page state information: an “accessed” bit and a “written into” bit. These bits are read by the operating system and indicate whether the page has been accessed

and, if so, whether it was written into. The accessed bit is used with operating system programs to determine which page should be overlaid with the new program page in systems that swap programs back and forth from a disk. The written into bit is used to determine whether the page to be overlaid must be swapped back to the disk or whether it is identical to a copy already there.

### **1.3.6 Instruction/Data Spaces**

The memory management unit can relocate data and instruction references with separate base address values; thus, it is possible to have a user program of 64K words consisting of 32K of pure procedure and 32K of data. Moreover, a convenient means of building reentrant shared programs is provided (these programs keep a separate data area for each user). The ability of the KT11-C option to relocate information with separate base address values enables shared compilers, assemblers, editors, and supervisors to be developed, in addition to providing an "execute-only" form of protection. With this form of protection, alterable data is automatically separated from reentrant code, and it is impossible to read any information relocated by an instruction base address as data.

### **1.3.7 Kernel/Supervisor/User Spaces**

The KT11-C provides three separate sets of pages (spaces) for use in the processor's Kernel, Supervisor, and User modes. These sets of pages increase system protection by physically isolating User programs from service Supervisor programs and the basic Kernel program. The service programs (compilers, editors, file system, assemblers, etc.) are also separated from the Kernel program (exception handling, I/O, memory management, etc.). Separate relocation register sets greatly reduced the time necessary to switch context between modes. The 3-space (page) construction also aids the user in designing an operating system that has clearly defined communications, is modular, and is easily debugged and maintained. During development cycles, these features result in time and cost savings; in the final system design, they result in an efficient and reliable system.

### **1.3.8 Program vs Stack Pages**

PDP-11 stacks expand by pushing words into lower addresses and thus grow downward; procedure sections increase by growing upward into higher addresses. All memory pages can be expanded by adding lower addresses (stack) or higher addresses (procedure, data). As a result, both stack and program pages are easily dynamically expanded.

### **1.3.9 Fault Recovery**

Four status registers record all information necessary to recover from a page fault. This information comprises the page number that faulted, the type of violation that caused the fault (exceeded length, read-only violation, etc.), and all information needed to easily restart the faulting instruction once the offending address has been made resident in memory.

### **1.3.10 Statistical Traps**

Three protection keys will cause a trap, i.e., an automatic transfer of program control to location 250 at end of current instruction. The trap feature is useful for gathering frequency-of-page-use statistics. One protection key traps on a read access to a read-only page; a second key traps on either a read or a write access from a read/write page; and the third key traps only on a write to a read/write page.

## **1.4 KT11-C MEMORY MANAGEMENT UNIT SPECIFICATIONS**

Table 1-1 is a summary of specifications and technical characteristics of the KT11-C.

**Table 1-1  
Abridged Specifications Summary**

| Characteristic       | Specification or Description   |
|----------------------|--|
| Memory Expansion     | Expands PDP-11/45 memory address capability up to 124K words.  |
| Interface            | Address line outputs compatible with PDP-11 Unibus and PDP-11/45 Fastbus.  |
| Timing               | Timing derived from basic KB11-A processor TIG module.   |
| Delay                | Adds 90 ns to every memory reference when enabled.   |
| Modes of Operation   | Implements the KB11-A processor Kernel, Supervisor, and User modes.  |
| Available Pages      | Provides sixteen 4K-word pages for each mode. (Eight for I space and eight for D space.)   |
| Page Length          | A page can vary in length from one 32-word block up to 128 32-word blocks. Maximum page length is therefore 4096 words.                                    |
| Program Capacity     | Eight 4096-word pages will accommodate 32K-word programs. Use of I and D space can provide 64K-word capacity (32K words of program and 32K words of data). |
| Page Fault Recovery  | Contains status registers that allow full recovery from page faults.   |
| Physical Description | Option consists of two standard hex modules (15 × 8.5 in.) that mount in PDP-11/45 CPU backplane assembly.   |
| SAP Module M8107     | Located in slot 14. Replaces SJB Module M8116, when installed.   |
| SSR Module M8108     | Located in slot 13.  |
| Power Requirements   | Provided by PDP-11/45 power system.  |
| SAP Module M8107     | 3A, +5.0 Vdc   |
| SSR Module M8108     | 3.3A, +5.0 Vdc   |
| Environmental        | Refer to overall PDP-11/45 specifications listed in <i>PDP-11/45 System Maintenance Manual</i> , DEC-11-H45A-D.  |



# CHAPTER 2

## OPERATION AND PROGRAMMING

This chapter describes the relocation, protection, and abort mechanisms of the KT11-C, all registers available to the programmer, and operating hints and procedures.

### 2.1 BASIC KT11-C MECHANISMS

#### 2.1.1 Address Relocation Mechanism

The current processor mode (Kernel, Supervisor, or User) bits (bits 14 and 15 in the processor status word) select one of three sets of 16 registers to serve as the page base on the current access. The logic, in combination with the PDP-11/45 processor address, selects either the subset of eight instruction base registers or the subset of eight data base registers within the set. All instructions, index words, absolute addresses, and immediate operands use the instruction base registers. All other references use the data base registers. Bits 13, 14, and 15 of the processor address are then employed as a 3-bit encoded index into the eight register subsets previously selected. This encoded index selects a specific base (relocation) register, and thus for each memory reference, one of 48 base registers is selected to perform the address relocation.

The content of the selected base register is an initial or base value in the physical address space. The base value is always a multiple of 32 words; as a result, the lowest 6 bits of the base address (bit 0 specifies byte address on the PDP-11) are always 0. In actuality, only the upper 12 bits of the base address are stored in the base registers because the lower 6 bits are by implication 0.

To form the final physical address, a displacement from the base specified by the lowest 13 bits of the processor address (the upper 3 bits have been stripped off as an index into the base registers) is added to the base value contained in the base register. Note that this mapping technique allows pages of variable length (32 to 4096 words) to be packed efficiently in physical memory. Also note that the use of pages with less than 4096 words will result in discontinuous virtual address spaces because in the virtual address space a page begins on a 4096-word boundary.

As a specific example consider program A, starting address 0, is relocated by the constant 6400, which provides an address of 6400 (Figure 2-1). If the next processor virtual address is 2, the relocation constant will then cause physical address  $6402_8$ , which is the second item of program A to be accessed. When program B is running, the relocation constant is changed to  $1000_8$ . Then program B virtual addresses starting at 0 are relocated to access physical addresses starting at  $10000_8$ . Using the active page address registers to provide relocation eliminates the need to "relink" a program each time it is loaded into a different physical memory location. To the processor, the program always appears to start at the same address. Note that the base address is stored in a Page Address Register (PAR).

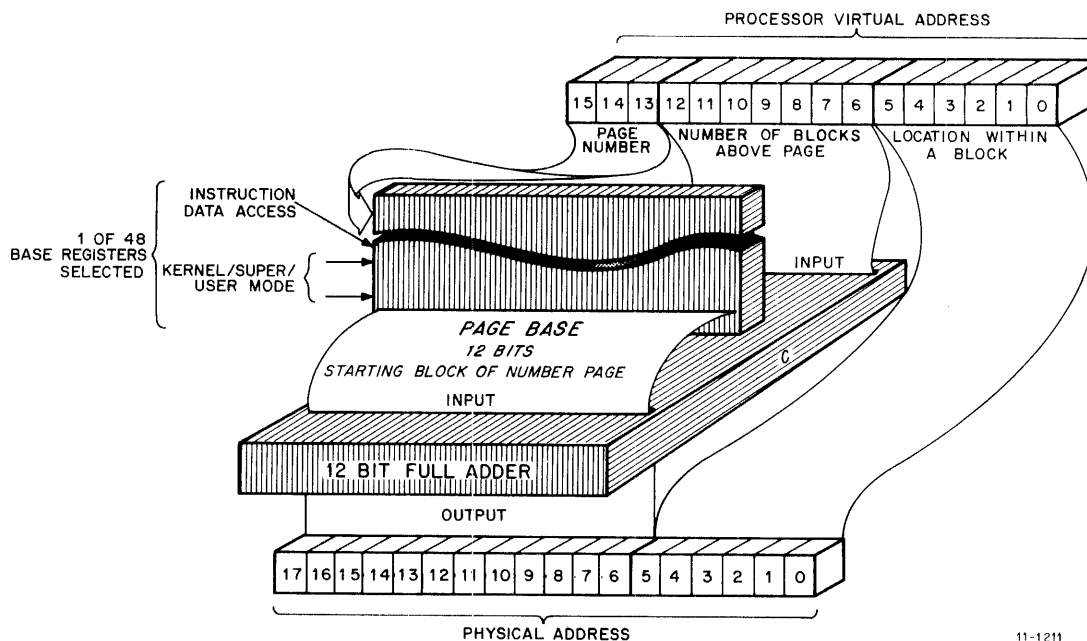

Figure 2-1 Basic KT11-C Relocation Mechanism

The relocation example shown in Figure 2-2 illustrates several points about memory relocation. These points are:

- a. Although the program appears to be in contiguous address space to the processor, the 32K-word virtual address space is actually relocated to several separate areas of physical memory. As long as the total available physical memory space is adequate, a program can be loaded. The physical memory space need not be contiguous.
- b. Pages may be relocated to higher or lower physical addresses, with respect to their virtual address ranges. In Figure 2-2, page 1 is relocated to a higher range of physical addresses, page 4 is relocated to a lower range, and page 3 is not relocated at all (even though its relocation constant is non-zero).
- c. All of the pages in the example start on 32-word boundaries.
- d. Each page is relocated independently. There is no reason two or more pages could not be relocated to the same physical memory space. Using more than one page address register in the set to access the same space is one way of providing different memory access rights to the same data, depending on which part of a program was referencing that data. Further information on memory protection is provided in Paragraph 2.1.2. In Figure 2-2, note that the same relocation constant is assigned to Pages 4 and 6. As a result, virtual addresses within both address ranges access the same physical addresses in memory, using separate page address registers.

When the KT11-C Memory Management Unit option is added to the PDP-11/45 system, the 16-bit KB11-A address output is no longer interpreted as the direct physical address of a device or a memory location. Instead, it is considered a 16-bit virtual address that contains information to be used by the KT11-C to construct an 18-bit physical address. Figure 2-3 shows how the 18-bit physical address is constructed. Virtual address bits (15:13) are interpreted as an active page field to select one of eight page registers in a set. Virtual address bits (12:06) provide the block number (0 to 177<sub>8</sub>) within the page; VA (05:00) indicate the displacement within each 32-word block. The Page Address Register (PAR) contains a Page Address Field (PAF) that is written into the PAR under program control when the program page is defined. Consider the PAF as the base address of the page.

The block number, VA <12:06>, is added to the base address PAF <11:00> to provide the 12 most significant bits of the physical address. This address and virtual address bits VA <05:00> (unchanged by relocation) form the 18-bit physical address.

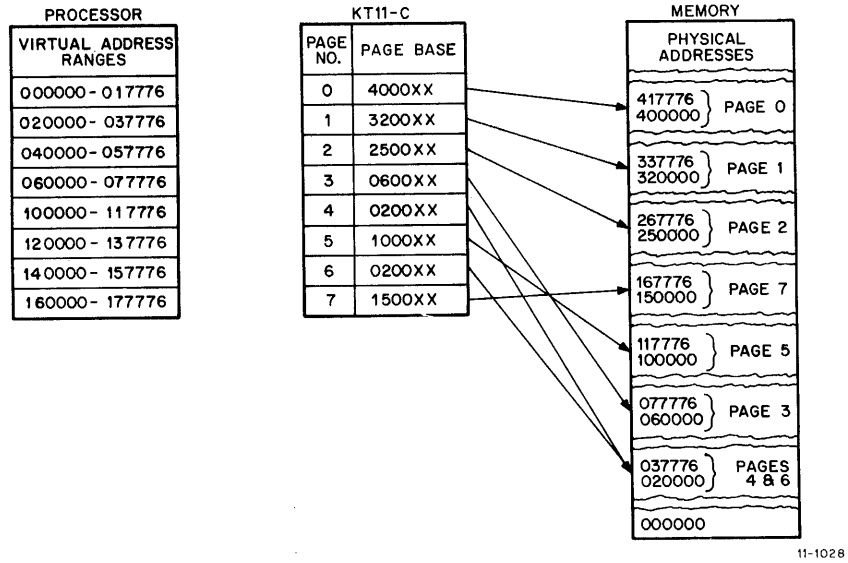

Figure 2-2 Relocation of a 32K-Word Program into 124K-Word Physical Memory

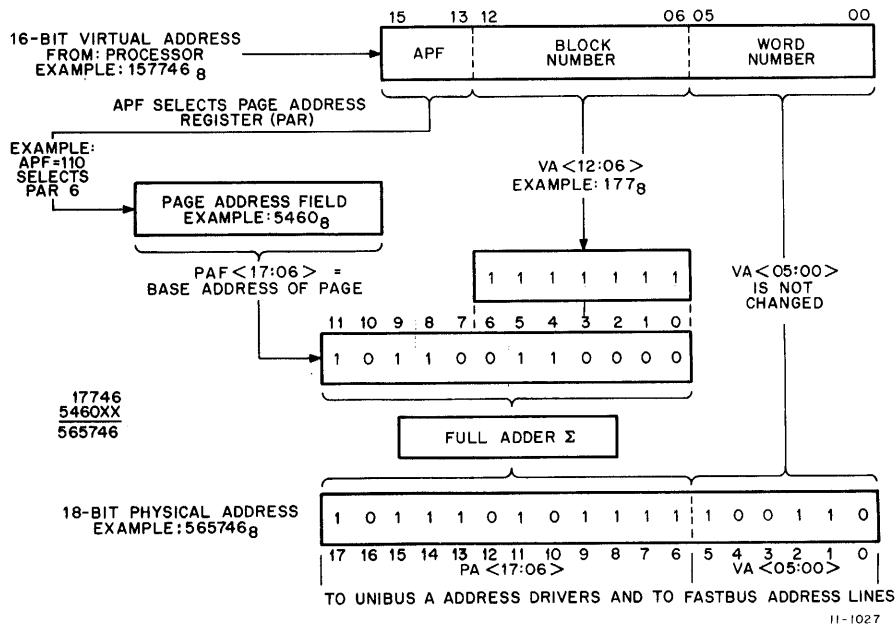

Figure 2-3 Construction of an 18-Bit Physical Address

## 2.1.2 Memory Protection Mechanisms

Three address protection mechanisms in the KT11-C provide non-resident and read-only protection, execute-only protection, and internal protection for the three processor mode address spaces.

**2.1.2.1 Non-Resident/Read-Only Protection** – A Page Descriptor Register (PDR) is selected in the same manner as a Page Address Register (PAR). After the selection occurs, three bits from the PDR are decoded as an access key. If the access rights designated by the key are inconsistent with the current memory reference, the memory reference is not completed and an abort to Kernel D space 250 occurs.

When the access key is set to 0, the page is defined as non-resident, and an immediate abort prevents any attempt by a program to access a non-resident page. Using this feature to provide memory protection, only those pages associated with the current program are set to legal access keys. The access control keys of all other program pages are set to 0, which prevents illegal memory references.

The access control key for a page can be set to 2, allowing read (fetch) memory references to the page but immediately aborting any attempt to write into the page. This read-only type of memory protection can be afforded to pages that contain common data, subroutines, or shared algorithms. This type of memory protection makes certain that access rights to a given information module are user-dependent, i.e., the access right to a given information module may be varied for different users by altering the access control key.

A Page Address Register in each of the sets (Kernel, User, and Supervisor modes) may be set up to reference the same physical page in memory and each may be keyed for different access rights. For example, the User access control key might be 2 (read-only access), the Supervisor access control key might be 0 (non-resident), and the Kernel access control key might be 6 (allowing complete read/write access).

**2.1.2.2 Execute-Only Protection** – The execute-only type of memory protection is part of an overall ability to use reentrant software, which prevents excessive use of memory space when a program is provided for several users. Such programs can be written in two parts. One part contains pure code that is not modified during execution and can be used to simultaneously service any number of users. For example, the pure code portion of FORTRAN can service multiple FORTRAN users. A separate second part of the program belongs strictly to each user and consists of the code and data that is developed during the compiling process. This portion is stored in a separate page of memory. Figure 2-4 shows a comparison of memory space for non-reentrant and reentrant systems.

The KT11-C hardware can differentiate between pure code memory references (which are instructions, immediate operands, index words, and absolute addresses) and all other memory references. When this feature is enabled under program control, the KT11-C will take the “pure code” portion of such a program from an I (instruction) space page. All other data will be put into an associated D (data) space page. Any illegal attempt by an unauthorized user to read from the execute-only I space will be relocated to a separate D space page. Because the I and D space pages have separate PDRs, access control can be keyed differently for each page. For example, the D space access control key could be set to 0 to cause a non-resident abort, or, as an alternative, the base address of the D space page could be set up to map over some other part of a user’s program. In any case, the D space PDR must not be set so that a user can write into the pure code I space. The difference between the read-only protection described in Paragraph 2.1.2.1 and execute-only

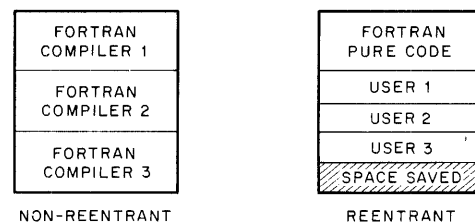

Figure 2-4 Comparison of Non-Reentrant and Reentrant Program Space Requirements

11-1034

protection is that the contents of execute-only pages cannot be read as data. This feature is particularly useful in protecting proprietary programs from some users. Paragraph 2.4.6 describes I and D space more fully.

In the special case when in User mode and the previous mode specified by the processor status is also User mode, the action of the MFPI instruction is modified so that the read is via the D relocation registers. In this manner, the integrity of the execute-only mode is reserved.

**2.1.2.3 Multiple Address Space Protection** — The three completely separate PAR/PDR sets provided by the KT11-C for each mode of processor operation (Kernel, Supervisor, and User) give the timesharing system another type of memory protection. The mode of operation is specified by the Processor Status Word current mode field.

The active page register sets are enabled as follows:

| PS (15:14) | PAR/PDR Set Enabled              |
|------------|----------------------------------|
| 00         | Kernel mode                      |
| 01         | Supervisor mode                  |
| 10         | Illegal (all references aborted) |
| 11         | User mode                        |

Thus, a User mode program is relocated by its own PAR/PDR set, as are Kernel and Supervisor programs. It is therefore impossible for a program running in one mode to accidentally reference space allocated to another mode when the active page registers are set correctly by a monitor program. For example, a user cannot transfer to Supervisor or Kernel space. The Supervisor mode address space may be reserved by the system to accommodate resident compilers, utility programs, and other shared resource programs. The Kernel mode address space may be reserved for resident system monitor functions, such as the basic Input/Output Control (IOC) routines, memory management trap handlers, abort handlers, and timesharing scheduling module. By dividing the types of timesharing system programs functionally between the Kernel, Supervisor, and User modes, a minimum amount of space control housekeeping is required as the timeshared operating system sequences from one user program to the next. For example, only the User PAR/PDR set needs to be updated as each new user program is serviced. The three PAR/PDR sets implemented in the KT11-C Memory Management Unit option are shown in Figure 2-5.

### 2.1.3 Memory Management Statistics Mechanism

A timeshared system swaps programs or parts of programs in and out of memory using secondary storage facilities such as disk or drum systems. In a swapping environment, the operating system must provide the software routines that decide what programs should be swapped and when and how these programs can be swapped between memory and secondary storage. The operating system routines can be simple or complex depending on system requirements, e.g., the amount of overhead time that can be tolerated. The operating system may also have to decide which active page is least likely to be required in the immediate future and may therefore be swapped out to make memory space available for a new program. To make such a memory management decision, the operating system requires statistics on the use of active pages. Some indication of whether a program has been modified during its residence in memory is also desirable. If it has been modified, the modified program must be swapped (re-written) into secondary storage. If no modification has been made and the program can always be re-called from secondary storage, the space it occupies in memory can be overlaid without swapping delay. The KT11-C logic provides the kind of information required by an operating system to gather memory management statistics on the use of active pages. The availability of this information in the hardware reduces the overhead time of any routine, simple or complex, in the efficient management of memory. In the

KT11-C, the Page Descriptor Register associated with each active page includes a W (written into) and an A (attention) bit. When any active page is written into, the W bit is set by the logic; therefore, by testing the W bit the memory management software routine can decide whether a page can be overlaid or if it needs to be swapped out.

The A bit has several uses. To use this feature the system programmer first enables the memory management trap logic. He can then set the access control keys of the active pages of interest for special trap conditions. Access control keys are provided to cause:

- a. Memory management trap on read (including instruction fetch)
- b. Memory management trap on write
- c. Memory management trap on read or write.

Then, the A bit for the active page is set when the page is accessed as specified and a resultant memory management trap occurs. The vector at trap location 250 Kernel address space causes the operating system routine to service the memory management trap. The routine can test the A bit to accumulate statistics on the use of that page. When a swapping decision is required of the operating system, these statistics can be examined to determine the more active pages (which might therefore be retained in memory).

### 2.1.4 Trap/Abort Mechanism

Memory references that violate the protection keys set in the KT11-C cause an interrupt in the processor. The interrupt process is described in Paragraph 5.3 of the *PDP-11/45 Handbook*. In KT11-C aborts and traps, the new PC for the abort/trap service routine is taken from 250 in Kernel virtual D space, while the new PS is taken from 252. No other interrupts use 250 as a trap vector. Note that both abort and statistical traps are taken to 250.

Non-resident, read-only, and page length violations cause an interrupt to the processor before the reference is made. Memory management traps occur only at the end of complete instructions. Paragraphs 3.11.1 and 3.11.2 describe the trap/abort logic and include two system diagrams that indicate how the interrupt is implemented in the logic. The order of interrupt service is listed in Appendix C of the *PDP-11/45 Processor Handbook*.

## 2.2 PAR/PDR REGISTERS

The contents of the Page Address Register (PAR) and the Page Descriptor Register (PDR) describe a memory page.

The KT11-C provides three sets of 16 PAR/PDR pairs. As indicated in Figure 2-5, one PAR/PDR set is used to reference memory while the processor is in Kernel mode, another in Supervisor mode, and the third in User mode. Each set is subdivided into two groups: one for reference to instruction (I) space and one for reference to data (D) space. Figure 2-5 shows the organization of the three sets. Each pair consists of a Page Address

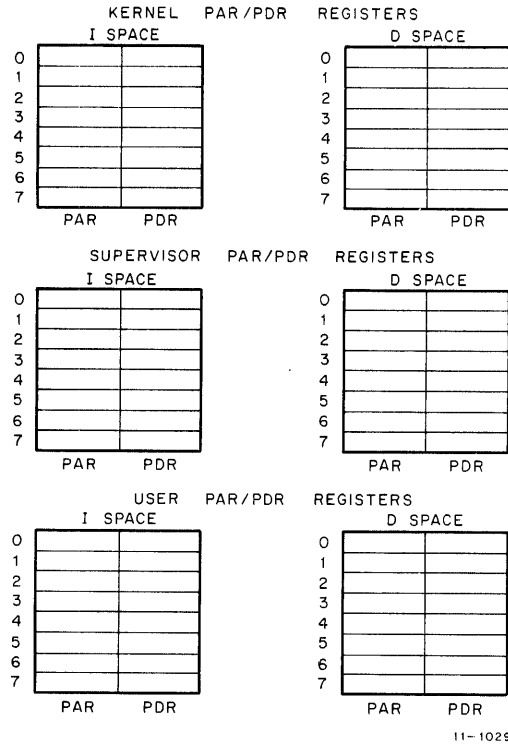

Figure 2-5 KT11-C Memory Management Unit PAR/PDR Registers

Register (PAR) and a Page Descriptor Register (PDR). These registers are always used as a pair and contain all the information required to locate and describe the current active pages for each mode of operation.

The current mode bits (bits 14 and 15) of the Processor Status Word determine which set will be referenced for each memory access. A program operating in one mode cannot use the PAR/PDR sets of the other two modes to access memory. Thus, the three sets are a key feature in providing a fully protected environment for a time-shared multiprogramming system. The virtual address value determines which page within a set is to be used. This correspondence is listed below:

| Page No. | Virtual Addresses |
|----------|-------------------|
| 0        | 000000 – 017777   |
| 1        | 020000 – 037777   |
| 2        | 040000 – 057777   |
| 3        | 060000 – 077777   |
| 4        | 100000 – 117777   |
| 5        | 120000 – 137777   |
| 6        | 140000 – 157777   |
| 7        | 160000 – 177777   |

Finally the use of the reference (part of an instruction or data access) determines whether the I space PAR/PDR set or the D space PAR/PDR set is used. Each PAR and PDR of every set is assigned to a specific processor I/O address. Table 2-1 is a complete list of address assignments.

**NOTE**

**Unibus devices cannot access PARs or PDRs.**

In a fully-protected multiprogramming environment, only a program operating in Kernel mode would be allowed to access the PAR and PDR locations for the purpose of mapping a user's programs. However, there are no restraints imposed by the KT11-C logic that will prevent Supervisor or User mode programs from accessing these registers. PAR and PDR are not cleared by INIT. The option of implementing such a feature in the operating system and thus explicitly protecting these locations from user's programs is available to the system software designer.

**2.2.1 Page Address Registers (PAR)**

The Page Address Register (PAR) shown in Figure 2-6 contains the base address of the page in the form of a 12-bit Page Address Field (PAF). Bits 15–12 of the PAR are not implemented in the hardware.

The PAR can also be thought of as a relocation register containing a relocation constant or as a base register containing a base address. Either interpretation indicates the basic function of the PAR in the relocation scheme.

Note that the PAF is interpreted in address calculations as a multiplier of 32, i.e., when used as a base register, the lowest 6 bits are assumed to be 0. The bit stored in bit 0 of the PAF becomes bit 6 of the page base address, bit 1 of the PAF, bit 7 of the page base address, etc. Thus, bit 11 of the PAF becomes bit 17 of the page base address.

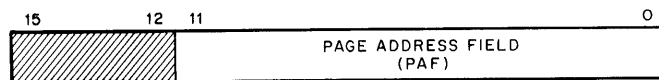

11-1036

Figure 2-6 Page Address Register (PAR) Format

**Table 2-1  
PAR/PDR Address Assignments**

| Kernel  |        |        |         |        |        |
|---------|--------|--------|---------|--------|--------|
| I Space |        |        | D Space |        |        |
| No.     | PAR    | PDR    | No.     | PAR    | PDR    |
| 0       | 772340 | 772300 | 0       | 772360 | 772320 |
| 1       | 772342 | 772302 | 1       | 772362 | 772322 |
| 2       | 772344 | 772304 | 2       | 772364 | 772324 |
| 3       | 772346 | 772306 | 3       | 772366 | 772326 |
| 4       | 772350 | 772310 | 4       | 772370 | 772330 |
| 5       | 772352 | 772312 | 5       | 772372 | 772332 |
| 6       | 772354 | 772314 | 6       | 772374 | 772334 |
| 7       | 772356 | 772316 | 7       | 772376 | 772336 |

| Supervisor |        |        |         |        |        |
|------------|--------|--------|---------|--------|--------|
| I Space    |        |        | D Space |        |        |
| No.        | PAR    | PDR    | No.     | PAR    | PDR    |
| 0          | 772240 | 772200 | 0       | 772260 | 772220 |
| 1          | 772242 | 772202 | 1       | 772262 | 772222 |
| 2          | 772244 | 772204 | 2       | 772264 | 772224 |
| 3          | 772246 | 772206 | 3       | 772266 | 772226 |
| 4          | 772250 | 772210 | 4       | 772270 | 772230 |
| 5          | 772252 | 772212 | 5       | 772272 | 772232 |
| 6          | 772254 | 772214 | 6       | 772274 | 772234 |
| 7          | 772256 | 772216 | 7       | 772276 | 772236 |

| User    |        |        |         |        |        |
|---------|--------|--------|---------|--------|--------|
| I Space |        |        | D Space |        |        |
| No.     | PAR    | PDR    | No.     | PAR    | PDR    |
| 0       | 777640 | 777600 | 0       | 777660 | 777620 |
| 1       | 777642 | 777602 | 1       | 777662 | 777622 |
| 2       | 777644 | 777604 | 2       | 777664 | 777624 |
| 3       | 777646 | 777606 | 3       | 777666 | 777626 |
| 4       | 777650 | 777610 | 4       | 777670 | 777630 |
| 5       | 777652 | 777612 | 5       | 777672 | 777632 |
| 6       | 777654 | 777614 | 6       | 777674 | 777634 |
| 7       | 777656 | 777616 | 7       | 777676 | 777636 |

**2.2.2 Page Descriptor Registers (PDR)**

The Page Descriptor Register (PDR) contains page expansion, direction, page length, and access control (Figure 2-7).

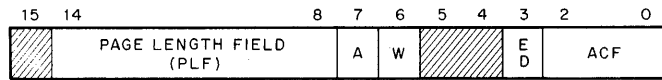

11-1037

Figure 2-7 Page Descriptor Register (PDR) Format

**2.2.2.1 Access Control Field (ACF)** – The ACF is a 3-bit field (occupying bits 2–0 of the PDR) that describes the access rights to this particular page. The access codes or “keys” specify the manner in which a page may be accessed and whether or not a given access should result in a trap or an abort of the current operation. A memory reference that causes an abort is not completed and is terminated immediately. Hence an aborted “read” reference does not obtain any data from the location, and an aborted “write” reference does not change the data in the location. A memory reference that causes a trap is completed. When a memory reference causes a trap, the trap does not occur until the entire instruction has been completed. Aborts are caused by attempts to access non-resident pages, page length errors, or access violations, such as attempting to write into a read-only page. Traps are used as an aid in gathering memory management information.

In the context of access control, the term *write* is used to indicate the action of any instruction that modifies the contents of any addressable word. A write is synonymous with what is usually termed a *store* or *modify* in many computer systems. Table 2-2 lists the ACF keys and their functions. The ACF is written into the PDR under program control.

Table 2-2  
Access Control Field Keys

| AFC | Key | Description                                     | Function  |
|-----|-----|---|---|
| 000 | 0   | Non-resident (NR)                               | Abort any attempt to access this non-resident page.   |
| 001 | 1   | Read only and trap (RROT)                       | Trap to location 250 in Kernel D space after read. Abort any attempt to write into this page.             |
| 010 | 2   | Resident read only (RRO)                        | Abort any attempt to write into this page.  |
| 011 | 3   | Illegal   | Unused. Reserved for future use. Abort any access attempt.  |
| 100 | 4   | Resident read/write and trap (RRWT)             | Memory management trap to location 250 in Kernel D space upon completion of a read or write to this page. |
| 101 | 5   | Resident read/write and trap when write (RRWTW) | Allows read/write of page and traps to location 250 in Kernel D space upon completion of a write.         |
| 110 | 6   | Resident read/write (RRW)                       | Read or write allowed. No trap or abort occurs.   |
| 111 | 7   | Illegal   | Unused. Reserved for future use. Abort any access attempts.   |

**2.2.2.2 Expansion Direction (ED)** – The ED bit located in PDR bit position 03 indicates the authorized direction in which the page expands. A logic 0 in this bit (ED = 0) indicates that the page expands upward from relative zero (page base address). A logic 1 in this bit (ED = 1) indicates that the page expands downward toward relative zero (page base address). The ED bit is written into the PDR under program control. When expansion is upward (ED = 0), the page length is increased by adding blocks with higher relative addresses. Upward

expansion is usually specified for program or data pages to add more program or table space. An example of page expansion upward is shown in Figure 2-8.

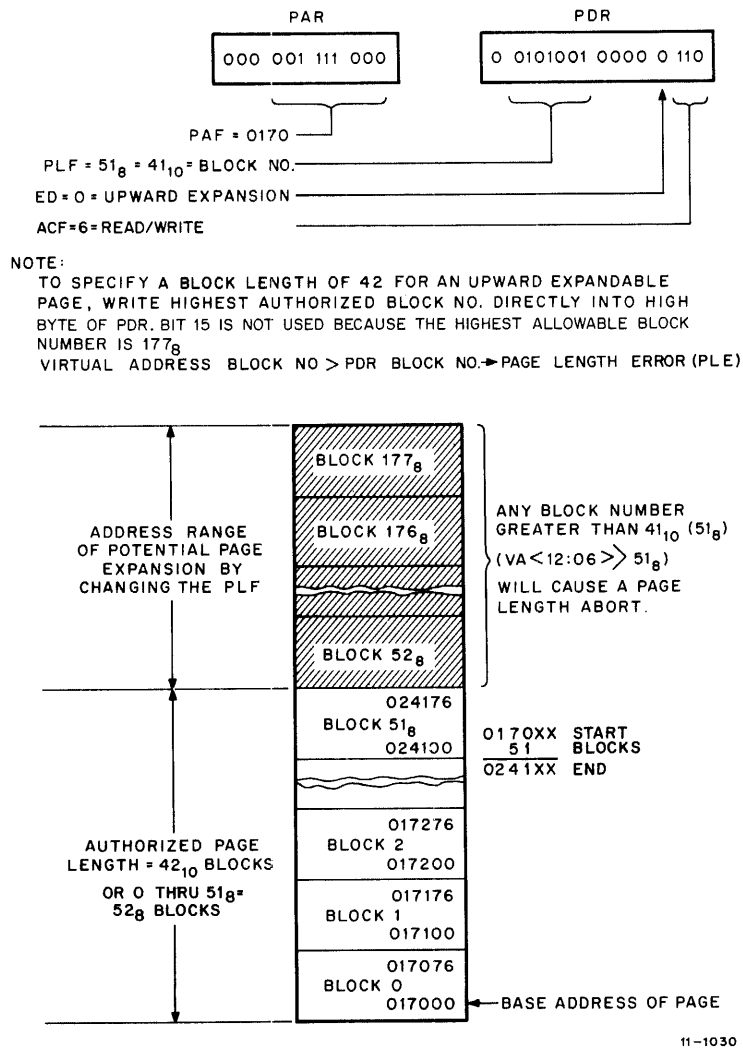
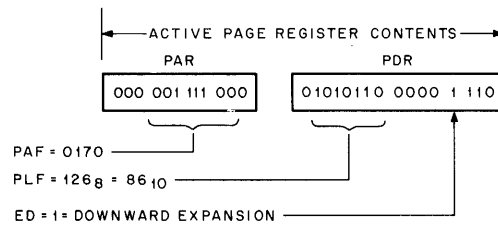

Figure 2-8 Example of an Upward Expandable Page (From the Base)

When expansion is downward (ED = 1), the page length is increased by adding blocks with lower relative addresses. Downward expansion is specified for stack pages so that more stack space can be added. An example of page expansion is shown in Figure 2-9. Paragraphs 2.5.3 and 2.5.4 provide a description of the interaction of the ED bit with the Page Length Field (PLF).

**2.2.2.3 Written Into (W)** – The W bit located in PDR bit position 06 indicates whether the page has been written into since it was loaded into memory. W = 1 is affirmative. Note that the W bit is set independent of the ACF key and the memory management enable bit (bit 9) in SR0. The W bit is automatically cleared when either the PAR or PDR of a page is written into. It can only be set by KT11-C control logic.



TO SPECIFY PAGE LENGTH FOR A DOWNWARD EXPANDABLE PAGE, WRITE COMPLEMENT OF BLOCKS REQUIRED INTO HIGH BYTE OF PDR.

IN THIS EXAMPLE, A 42-BLOCK PAGE IS REQUIRED.  
 PLF IS DERIVED AS FOLLOWS:  
 42<sub>10</sub> = 52<sub>g</sub>; TWO'S COMPLEMENT = 126<sub>g</sub>  
 VIRTUAL ADDRESS BLOCK NO. <PDR BLOCK NO. → PAGE LENGTH ERROR (PLE)

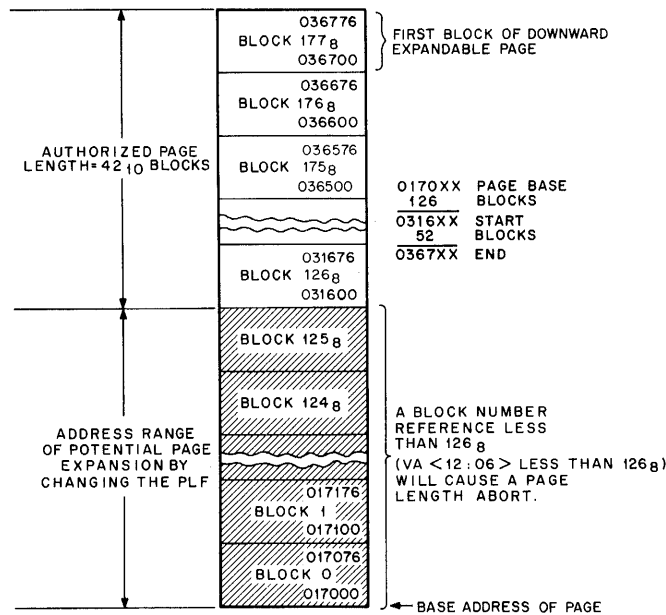

11-1031

Figure 2-9 Example of a Downward Expandable Page  
(From Top of Page Toward Base)

In disk swapping and memory overlay applications, the W bit can be used to determine the pages in memory that have been modified by a user. Those that have been written into must be saved in their current form; those that have not been written into (W = 0), need not be saved and can be overlaid with new pages if necessary.

**NOTE**

The W bit cannot be set by a memory access of a KT11-C internal register or a memory access that causes an abort.

**2.2.2.4 Attention (A)** – The A bit located in PDR bit position 07 indicates whether any memory page accesses caused memory management trap conditions to be true. A = 1 is affirmative. Trap conditions are specified by the ACF. The following conditions will set the A bit.

1. ACF = 001 and read reference.
2. ACF = 100.
3. ACF = 101 and write reference.

Note that the A bit is set independent of the memory management enable bit (bit 9) in SR0. The A bit is used in the process of gathering memory management statistics for the purpose of optimizing memory use. The A bit is automatically cleared when the PAR or PDR of the page is written into. It can only be set by the KT11-C control logic.

**NOTE**

**The A bit cannot be set by a memory access of a KT11-C internal register or a memory access that causes an abort.**

**2.2.2.5 Page Length Field (PLF)** – The 7-bit PLF is located in PDR bits <14:08>. It specifies the authorized length of the page in 32-word blocks. The PLF holds block numbers from 0 to  $177_8$ , thus allowing any page length from 1 to  $128_{10}$  blocks. The PLF is written in the PDR under program control.

*PLF for an Upward Expandable Page*

When the page expands upward, the PLF must be set to one less than the intended number of blocks authorized for that page. For example, if  $42_{10}$  blocks are authorized, the PLF is set to  $51_8$  ( $41_{10}$ ) (Figure 2-8). The KT11-C hardware compares the virtual address block number, VA <12:06>, with the PLF to determine if the virtual address is within the authorized page length. When the virtual address block number is less than or equal to the PLF, the virtual address is within the authorized page length. If the virtual address block number is greater than the PLF, a page length fault (address too high) is detected by the hardware and an abort occurs. In cases where the authorized page length is less than 4096 words, the virtual address space legal to the program is non-contiguous. This is because the three most significant bits of the virtual address are used to select the PAR/PDR set, and the unauthorized virtual addresses within the page space are “lost”. The operating system abort recovery routines might include some form of dynamic memory allocation. Such routines would have to perform the following:

1. Determine the cause of the abort (page length fault).
2. Check the expansion direction bit (upward).
3. Allocate an additional block or more of memory space by incrementing the PLF in the case of an upward expandable page.
4. Correct the general registers modified by the partially completed operation.
5. Return control to the user program and thus allow the now legal virtual address memory reference to be completed.

Note that Paragraph 2.4.10 contains such a recovery routine.

*PLF for a Downward Expandable Page*

The downward expansion capability for a page is intended specifically for those pages that are to be used as stacks. In the PDP-11, a stack starts at the highest location reserved for it and expands downward toward the lowest address as items are added to the stack. (See Chapter 5 of the *PDP-11/45 Processor Handbook* for

complete details.) When the page is to be downward expandable, the PLF must be set to authorize a page length, in blocks, that starts at the highest address of the page, i.e., always block  $177_8$ . Figure 2-9 shows an example of a downward expandable page. A page length of  $42_{10}$  blocks is arbitrarily chosen so that the example can be compared with the upward expandable example shown in Figure 2-8.

**NOTE**

The same PAF is used in both examples to emphasize that the PAF, as the base address, always determines the lowest address of the page, whether it is upward or downward expandable.

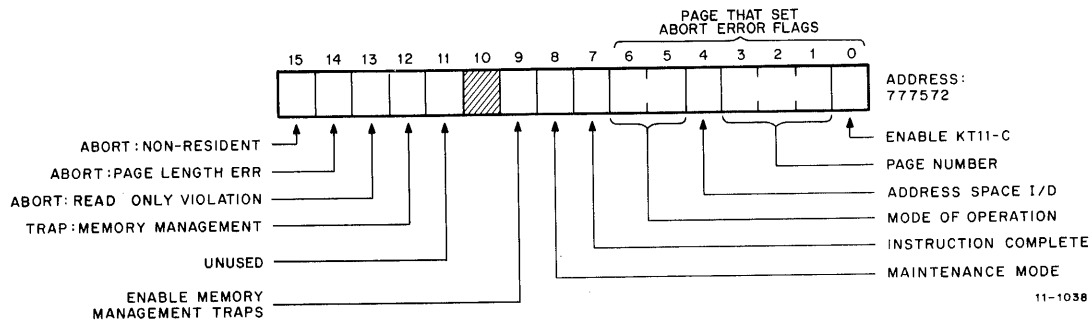

Figure 2-10 Format of Status Register 0 (SR0)

To calculate the value to be placed in the PLF for a downward expandable page proceed as follows.

Take the number of 32-word blocks to be authorized and create the negative of it in 2's complement notation. The 2's complement is formed by negating each binary bit, then adding 1 to the result.

**Example:**

$$\begin{array}{rcl}
 52_8 & = & 0101010 \\
 \text{bit negation} & = & 1010101 \\
 \text{add} & & \underline{\quad 1} \\
 126_8 & = & 1010110
 \end{array}$$

The same dynamic memory allocation routine can be used to recover from a page length abort. After determining that the page was downward expandable, the PLF would be decremented to allow downward expansion.

**2.3 MEMORY MANAGEMENT STATUS REGISTERS**

Aborts and traps generated by the KT11-C logic are vectored through Kernel D space address location 250. Status Registers SR0, SR1, and SR2 can be referenced by fault recovery routines to differentiate between an abort and a trap, determine why the abort or trap occurred, perform the service routines required to recover from the abort or handle the trap, and allow for program restart. The following paragraphs describe the formats of each status register.

### 2.3.1 Status Register 0 (SR0)

SR0 contains abort error flags, memory management enable and trap flag bits, plus other essential information required by an operating system to recover from an abort or to service a memory management trap. The physical address of SR0 is 777572. The SR0 format is shown in Figure 2-10.

Bits 15–11 are the abort and trap flags, and can be considered to be in a “priority queue” in that “flags to the right” are less significant and should be ignored. For example, a “non-resident” abort service routine would ignore page length, access control, and memory management flags. A “page length” abort service routine would ignore access control and memory management faults.

#### NOTE

**Bits 15, 14, or 13, when set (abort conditions) cause the KT11-C logic to freeze the contents of SR0 bits 1–7 and status registers SR1 and SR2 to facilitate recovery from the abort.**

The error flag bits 15–12 are enabled when an address is being relocated by the KT11-C. This implies that either SR0, bit 0 is equal to 1 (KT11-C operating) or that SR0, bit 8 is equal to 1 and the memory reference is the final one of a destination calculation (maintenance/destination mode).

Note that SR0 bits 0, 8, and 9 can be set under program control to provide meaningful memory management control information. However, information written into all other bits is not meaningful. Only that information automatically written into these remaining bits as a result of hardware actions is useful as a monitor of the status of the memory management unit. Setting bits 15–11 under program control will not cause aborts or traps to occur. Bits 15–11 must be reset to 0 after an abort or trap has occurred in order to resume monitoring memory management. Setting bits 15, 14, or 13 will, however, freeze the contents of SR0 bits <1:7>, Status Register 1 (SR1) and Status Register 2 (SR2).

**2.3.1.1 Abort-Nonresident** – Bit 15 is the “Abort-Nonresident” bit. It is set by attempting to access a page with an access control field (ACF) key equal to 0, 3, or 7.

**2.3.1.2 Abort-Page Length** – Bit 14 is the “Abort Page Length” bit. It is set by attempting to access a location in a page with a virtual address block number (Virtual Address bits <12:06>) that is outside the area authorized by the Page Length Field (PLF) of the PDR for that page. Bits 14 and 15 of SR0 may be set simultaneously by the same access attempt.

**2.3.1.3 Abort-Read Only** – Bit 13 is the “Abort-Read Only” bit. It is set by attempting to write in a page with an access key of 1 or 2.

**2.3.1.4 Trap-Memory Management** – Bit 12 is the “Trap-Memory Management” bit. It is set by a read operation that references a page with an ACF key of 1 or 4 and by a write operation with an ACF key of 4 or 5. The functions of these ACF keys are listed in Table 2-2. Note that the “Enable Memory Management” bit (SR0, bit 9) must be a 1 for the “Trap-Memory Management” bit to be set.

**2.3.1.5 Bit 11** – Bit 11 is a spare flag reserved for future use.

**2.3.1.6 Enable Memory Management** – Bit 9 is the “Enable Memory Management” bit. It can be set or cleared by doing a direct write into SR0. If bit 9 is cleared, no memory management traps can occur. The A and W bits will, however, continue to log potential memory management traps. When bit 9 is set to 1, the next memory management trap condition will cause a trap, vectored through Kernel D virtual address 250.

**NOTE**

If the instruction that clears bit 9 (to disable memory management) causes a potential memory management trap in the course of any of its memory references prior to the one actually changing SR0, the trap will occur at the end of the instruction.

**2.3.1.7 Maintenance/Destination Mode** – Bit 8 specifies maintenance use of the memory management unit. It is used for KT11-C diagnostic purposes. For the instructions used in the initial diagnostic program, bit 8 is set so that only the final destination reference is relocated. This bit must not be used for other purposes.

**2.3.1.8 Instruction Completed** – When an abort has occurred, bit 7 indicates that the current instruction has been completed and that the current memory references are caused by an interrupt or “T” bit, Parity, Odd Address or Timeout traps.

**2.3.1.9 Abort Recovery Information** – When an abort occurs, bits (1:6) of SR0 contain the information necessary to determine which of the 48 pages caused the abort. Specifically, bits (1:6) contain the processor mode, whether I or D space, and which 4K page within mode-space.

*Mode of Operation*

Bits 5 and 6 indicate the CPU mode (User/Supervisor/Kernel) associated with the page causing the abort or trap (Kernel = 00, Supervisor = 01, User = 11). These bits are controlled by the KT11-C logic that decodes current previous mode bits of the PSW.

*Address Space I/D*

Bit 4 indicates the type of space (I or D) being accessed (0 = I Space, 1 = D Space). It is controlled by the KT11-C logic that selects I/D space.

*Page Number*

Bits 3–1 contain the page number of a reference. Pages, like blocks, are numbered from 0 upwards. The page number and address space bits are used by the error recovery routine to identify the page being accessed if an abort occurs.

**2.3.1.10 Enable KT11-C** – Bit 0 is the “Enable KT11-C” bit. When it is set to 1, all addresses are relocated and protected by the memory management unit. When bit 0 is set to 0, the memory management unit is disabled and addresses are neither relocated nor protected. Note that with this bit 0, all programs that run on the PDP-11/20 will run on the PDP-11/45.

**2.3.2 Status Register 1 (SR1)**

SR1 records any autoincrement/autodecrement of the general purpose registers, excluding implicit changes to the PC. The physical address of SR1 is 777574. SR1 is cleared at the beginning of each instruction fetch and interrupt. When a general register is autoincremented or autodecremented, the register number and the amount

(in 2's complement notation) by which the register was modified is written into SR1 (Figure 2-11). The information contained in SR1 is necessary to accomplish an effective recovery from an abort. The low order byte is written first, and it describes the first general register that was changed. If a second general register is changed by the instruction, that change information is written into the high order byte of SR1. It is not possible for a PDP-11 instruction to autoincrement/autodecrement more than two general registers per instruction before an "abort-causing" reference. Because only three bits are provided for the general register number, it is up to the software to determine which set of registers (User/Supervisor/Kernel-General Set 0/General Set 1) was modified by determining the CPU and Register modes as contained in the Processor Status Word (PSW) at the time of the abort. SR1 is read-only; a write attempt will not modify its contents.

### 2.3.3 Status Register 2 (SR2)

SR2 is loaded with the 16-bit Virtual Address (VA) at the beginning of each instruction fetch, or with the address Trap Vector at the beginning of an interrupt; "T Bit" trap, Parity, Odd Address, and Timeout traps are also loaded with the trap vector. The physical address of SR2 is 777576. SR2 is read-only; a write attempt will not modify its contents. SR2 is the Virtual Address Program Counter (Figure 2-12).

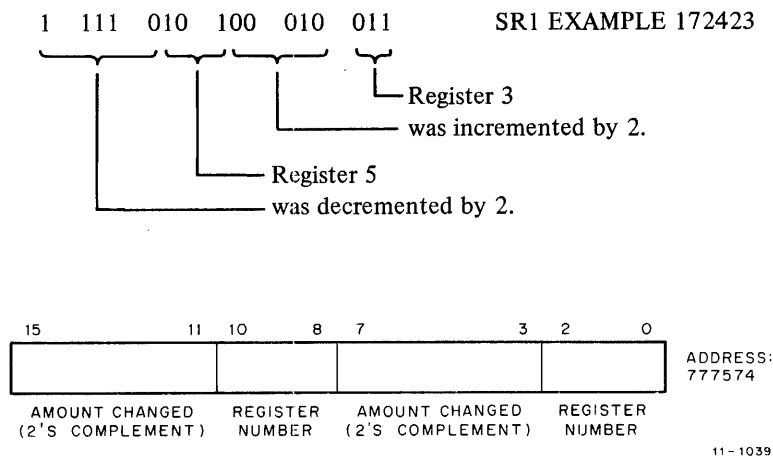

Figure 2-11 Format of Status Register 1 (SR1)



Figure 2-12 Format of Status Register 2 (SR2)



Example:

$$\begin{array}{r}
 \text{VA} = 167456 = \quad \text{xxx0 111 100 101 110} \\
 + (\text{PAR}) = 3456 = 011 100 101 110 \\
 \hline
 \text{PA} = 355256 = 011 101 101 010 101 110
 \end{array}$$

Where x indicates these bits are not used in the calculation.

**Table 2-3**  
Address Display Select Switch

| Switch Position                   | Interpretation and Use  |
|-----------------------------------|---|
| PROG PHY                          | Program Physical Address: Physical (relocated) addresses accessed by the program. This position is used for single stepping through the program being relocated. It will always display the actual memory address of the location being accessed. |
| CONS PHY                          | Console Physical Operations: Used for examines or deposits to a physical address whether the KT11-C is enabled or not. It will display the address loaded from the console switch register.   |
| USER, SUPER, or<br>KERNEL, I or D | Virtual Address: Used for examines or deposits to the virtual address when the current physical location may be unknown. These positions always display the address generated by the KB11-A processor.  |

**NOTE**

A detailed description of the source of individual address bits is provided in Paragraph 3.5.1.

**Table 2-4**  
Relating Virtual Address to PAR/PDR Set

| Virtual Address Range | PAR/PDR Set |
|-----------------------|-------------|
| 000000 – 17776        | 0           |
| 020000 – 37776        | 1           |
| 040000 – 57776        | 2           |
| 060000 – 77776        | 3           |
| 100000 – 117776       | 4           |
| 120000 – 137776       | 5           |
| 140000 – 157776       | 6           |
| 160000 – 177776       | 7           |

### 2.4.3 Protection Without Relocation

To obtain a one-to-one mapping of virtual address space to physical address space (no relocation), a value must be placed in each PAR to be accessed, because the three most significant bits of the virtual address are “stripped” to select the PAR/PDR set. Therefore, these three bits must be “mirrored” by the contents of each PAR, as indicated in the chart on the following page.

| PAR | Contents |
|-----|----------|
| 0   | 000000   |
| 1   | 000200   |
| 2   | 000400   |
| 3   | 000600   |
| 4   | 001000   |
| 5   | 001200   |
| 6   | 001400   |
| 7   | 001600   |

**NOTE**

If PAR 7 is to address the I/O page, its contents must be 007600.

**2.4.4 Communication Between User/Supervisor/Kernel Address Space**

A program in one address space can communicate with a program in another address space using three basic methods. The simplest method is to make a part of each program common by overlapping physical address space. A second method is to use the MTPD, MTPI, MFPD, and MFPI instructions. These instructions are defined in Chapter 4 of the *PDP-11/45 Processor Handbook*. A third method is to use the “return from interrupt” (RTI) instruction. These methods are described in the following paragraphs.

**2.4.4.1 Overlapping Physical Addresses** – Consider the problem of providing a buffer area to move data to and from I/O devices through the monitor/file system. Without overlapping, the data would be brought into a buffer area located in Kernel data space. It would then be moved into a separate buffer area in User space. However, using KT11-C memory mapping capabilities, a single buffer area can be located in physical memory with provisions for access by User, Supervisor, and Kernel mode programs. This method saves the additional memory space required for separate buffer areas and also the time required to move data from one buffer area to another.

**2.4.4.2 MFPI and MTPD Instructions Use** – In the following example, a word is popped off the Kernel stack and pushed onto the User stack. This method of stack-to-stack communication is typical of well-defined operating system communication. Assume that the processor is running in the Kernel mode and the previous mode was the User mode. The MFP and MTP instructions are double operand instructions and the missing operand is always the stack of the mode you are in.

|      |    |      |  | Internal Register<br>Transfers                     |
|------|----|------|--|--|
| 0065 | SS | MFPI | R6   |  |
|      |    |      | ;GET CURRENT VALUE OF USER STACK POINTER.<br>;PUSH IT ONTO KERNEL STACK. NOTE<br>;THAT SINCE ALL GENERAL REGISTERS ARE<br>;IN BOTH I AND D SPACE, THIS INSTRUCTION<br>;COULD HAVE BEEN “MFPD”. | -(R6) ← (R17)<br>KER SP USER SP                    |
|      |    | MOV  | (R6) +, R1   |  |
|      |    |      | ;POP USER R6 VALUE OFF KERNEL STACK.<br>;PUT IT IN GENERAL REGISTER 1.   | R1 ← + (R6)<br>KER SP                              |
| 1066 | DD | MTPD | -(R1)  |  |
|      |    |      | ;POP ARGUMENT OFF KERNEL STACK. PUT<br>;IT ON TOP OF USER STACK.   | (R17) ← -(R1)<br>USER SP<br>(R1) ← +(R6)<br>KER SP |
|      |    |      | ;ADDITIONAL WORDS MOVED HERE   |  |
|      |    | MOV  | R1, -(R6)  |  |
|      |    |      | ;PUT CORRECTED USER STACK POINTER ON<br>;KERNEL STACK.   | -(R6) ← R1<br>KER SP                               |
| 0066 | DD | MTPI | R6   |  |
|      |    |      | ;POP CORRECTED USER R6 VALUE OFF KERNEL<br>;STACK AND PUT IN USER R6. (INSTRUCTION<br>;COULD HAVE BEEN “MTPD”).  | (R17) ← +(R6)<br>USER SP KER SP                    |

The use of MTPI and MFPI is restricted in the User mode. If the previous mode bits (13:12) of the PS word also specify User mode (11), then the following restriction is implemented to preserve the integrity of execute-only protection. The execution of a MFPI will be relocated by the equivalent D space PAR/PDR register set if “D” space for the User mode is enabled (SR3, bit 0 = 1). This prevents a user from using MFPI to read from an execute-only page in his address space.

**2.4.4.3 Control Information** – Control is passed inward from User and Supervisor modes to the Kernel mode by all traps and interrupts. All trap and interrupt vectors are located in Kernel virtual address space. Thus, all traps and interrupts pass through Kernel space to obtain their new PC and PS, and determine the new mode of processing. Control is passed outward from the Kernel mode to the User and Supervisor modes by the RTT and RTI instructions, which restore the old PC and PS by popping them from the stack.

#### 2.4.5 Statistical Aids Use

Three ACF keys (1, 4, and 5) can cause traps at the end of the current instruction when the Enable Memory Management Traps bit is set in the SRO. These keys also cause the A bit in the associated PDR to be set, regardless of whether the Enable Memory Management Trap bit is set. A PDP-11 double operand instruction can access up to six different pages of memory during execution. If each of the six PDRs had ACF keys that specified memory management traps, then the A bit in each of the PDRs will have been set by the time the instruction is completed and the memory management trap service routine is entered. A statistic gathering service routine that collects “frequency of use” data can scan all PDRs and thus gather A bit information from all six PDRs that might have been set. The status registers are set only once. Therefore, if the statistical facility is to collect valid frequency of use on pages, a more elaborate approach is required of the software service routine.

One approach is to leave the Enable Memory Management Trap bit reset to 0, so that no traps occur, but set the ACF keys to specify the appropriate traps. This will cause the A bit to be set. Then, use a real-time clock to interrogate the A bits. When one is found set, a count location corresponding to that page can be incremented, and then that A bit must be cleared in the PDR.

One way to clear the A bit is to write into the PDR. For example, the instruction:

```
MOV    @#PDR,    @#PDR
```

will clear the A and W bits, but leave all other PDR bits unchanged. A less complex way is to set all read-only page ACF keys equal to 1 and all read/write page ACF keys equal to 4. At the end of the user time period, interrogate the A and W bits. Most state transitions with the ACF can be accomplished by incrementing the PDR. The ACF keys change as follows:

| Original ACF Key | New ACF Key | Effect of ACF Key Change                      |
|------------------|-------------|---|
| 1                | 2           | No memory management trap on read.            |
| 4                | 5           | No memory management trap on read.            |
| 5                | 6           | No memory management trap on write.           |
| 4                | 6           | No memory management trap on a read or write. |

Thus, by incrementing the ACF key, characteristics of the original key that are no longer required are deleted by the new key. Other essentials are retained by the new key. For example, when the ACF key increments from 1 to 2, the KT11-C still aborts any attempt to write into that page.

## 2.4.6 I and D Space Use

### NOTE

To use separate I and D space, a programmer must be able to write pure procedure code. The use of I and D space is an advanced technique that should not be attempted by novice programmers.

Eight I space PAR/PDR pairs accommodate up to 32K instruction words and eight D space PAR/PDR pairs accommodate up to 32K data words. By using the separate I and D space PAR/PDR pairs, a maximum 64K-word program capacity is possible. The following rules apply to any separate I and D space programs.

1. I space can contain only instructions, immediate operands (Mode 2, Register 7), absolute addresses (Mode 3, Register 7), and index words (Modes 6 and 7).
2. The stack page must be mapped into both I and D space if the Mark instruction is used (standard PDP-11/45 subroutine calling sequence), because it is executed off the stack.
3. I space only pages cannot contain subroutine parameters, which are data. Therefore, any page that contains standard PDP-11/20 calling sequences for example cannot be mapped into an I space page.
4. The trap catcher technique of putting .+2 in the TV followed by a halt must be mapped into both I space and D space.

The following chart shows the separation of I and D references for all address modes and all registers. Note that all registers (R0–R7) are in both spaces.

| Mode             | Register | Name                         |                |         |
|------------------|----------|------------------------------|----------------|---------|
| 000              | X        | Register                     | INSTRUCTION    | I space |
| 001              | X        | Register Deferred            | INSTRUCTION    | I space |
|                  |          |                              | DATA           | D space |
| 010              | 0–6      | Autoincrement                | INSTRUCTION    | I space |
|                  |          |                              | DATA           | D space |
|                  | 7        | Immediate                    | INSTRUCTION    | I space |
|                  |          |                              | IMMEDIATE DATA | I space |
| 011              | 0–6      | Autoincrement Deferred       | INSTRUCTION    | I space |
|                  |          |                              | INDIRECT       | D space |
|                  |          |                              | DATA           | D space |
|                  | 7        | Absolute                     | INSTRUCTION    | I space |
| ABSOLUTE ADDRESS |          |                              | I space        |         |
| DATA             |          |                              | D space        |         |
| 100              | 0–6      | Autodecrement                | INSTRUCTION    | I space |
|                  |          |                              | DATA           | D space |
|                  | 7        | DO NOT USE THIS CONSTRUCTION |                |         |

(continued on next page)

| Mode | Register | Name                         |             |         |
|------|----------|------------------------------|-------------|---------|
| 101  | 0–6      | Autodecrement Deferred       | INSTRUCTION | I space |
|      |          |                              | INDIRECT    | D space |
|      |          |                              | DATA        | D space |
|      | 7        | DO NOT USE THIS CONSTRUCTION |             |         |
| 110  | X        | Index                        | INSTRUCTION | I space |
|      |          |                              | INDEX       | I space |
|      |          |                              | DATA        | D space |
| 111  | X        | Index Deferred               | INSTRUCTION | I space |
|      |          |                              | INDEX       | I space |
|      |          |                              | INDIRECT    | D space |
|      |          |                              | DATA        | D space |

Note that when D space is not enabled for a mode by setting the proper bit in SR3, all memory references are relocated and protected by the I space set of PAR/PDR registers.

#### 2.4.7 I/O Operations

**2.4.7.1 Kernel Mode Protection** – All I/O operations should be performed by programs running in Kernel space, forcing User and Supervisor programs to call upon a Kernel mode routine to perform their I/O operations. This precaution increases system reliability by preventing possible errors by User and Supervisor programs. This precaution is necessary because the physical addresses issued by NPR devices on the Unibus are not relocated by the KT11-C. Therefore, proper I/O transfers between NPR devices and relocated memory depends upon careful checking of I/O requests by the Kernel mode routines; proper I/O transfers provide relocated memory addresses and ensure that the referenced pages of memory are resident and authorized.

**2.4.7.2 Avoiding I/O Lockout** – If the Kernel mode is used to handle all I/O operations, the programmer must ensure that the Kernel space to which the I/O routines are assigned never becomes non-resident. If this occurs, it becomes impossible to access the PAR/PDR sets to re-establish residency and to turn the KT11-C off by accessing bit 0 of SR0.

One method of recovering from such a situation is to execute a RESET instruction, which will disable the KT11-C relocation logic and allow direct I/O access again.

#### 2.4.8 Processor Status Word

In addition to the material below consult Paragraph 4.5 in the *KB11-A Maintenance Manual*.

##### 2.4.8.1 Explicit References to PS

- a. If the following three instructions cause a page fault on the “write” into the destination address, the PS condition codes may be modified.

```
MOV PS, (dst modes 3, 4, 5, 6, 7)
MFPI PS
MFPD PS
```

This may cause a different PS to be stored when the instruction is restarted.

(continued on next page)

- b. The sequence

SPL  
WAIT

should be used with care. Note that the processing of a KT11-C abort (page fault) may occur on the fetch of the WAIT instruction. Hence, priority levels must be carefully controlled or the interrupt that was expected to transfer control from the WAIT instruction may occur before the execution of the WAIT instruction.

**2.4.8.2 Implicit Modification of the PS** – When a KT11-C abort occurs, the PS condition code may have already been modified by the partially completed instruction. However, in all cases except those described in Paragraph 2.4.8.1, restarting the aborted instruction still causes the condition codes to be set to the expected value.

#### **2.4.9 Non-Recoverable Aborts**

Instructions that have autoincremented (popped) the Kernel stack pointer cannot be properly restarted, if they cause an abort. When an instruction that pops something off the Kernel stack causes an abort, it cannot be restarted because the abort mechanism pushes two items (old PS and PC) onto the Kernel stack. The first of these pushes wipes out the item that the abort-causing instruction previously tried to pop off the stack.

#### **NOTE**

**The MTPI and MTPD instructions in particular are non-recoverable if done in Kernel mode to an illegal user area.**

#### **2.4.10 Page Fault Recovery**

This paragraph presents an approach to recovering from either non-resident page faults or demands for a larger page. The description comprises a flow chart and sample program code with notation and includes only material that directly relates to using the KT11-C status registers properly. Emphasis is placed on proper procedure for restarting once the new page is defined and authorized.

The recovery routine takes one of two paths. The flow chart (Figure 2-14) shows that the correct path is determined by the Instruction Complete (IC) bit in status register SR0. If the IC bit is 1, then the “emulate aborted interrupt” path is taken. If the IC bit is 0, then the “general register backup/instruction restart” path is taken. Remember that the IC bit indicates if the aborted memory access was part of an instruction (IC = 0) or part of an interrupt or trap (IC = 1), as described in Paragraph 2.3.1.8.

**2.4.10.1 Definitions** – Table 2-5 lists the definitions of mnemonics used in Figure 2-14.

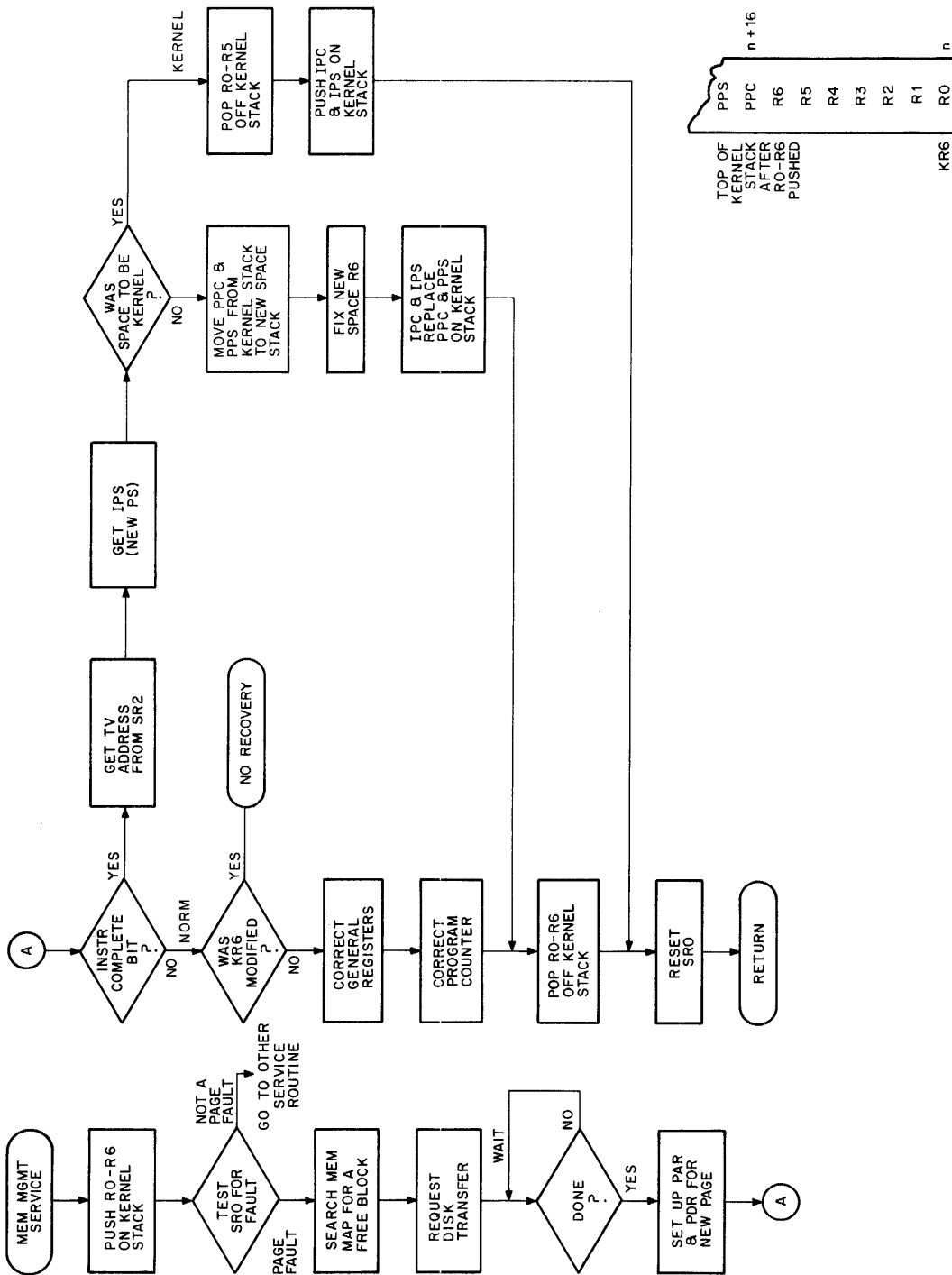

11-042

Figure 2-14 Flow Chart for a Page Fault Recovery Routine

**Table 2-5**  
**Mnemonic Definitions**

| Mnemonic | Definition   |
|----------|--|
| APC      | Abort Program Counter. The value of the contents of location 250. This value normally is the starting address of the KT11-C Abort/Trap Service Routine. Location 250 is the address of the KT11-C Trap Vector.   |
| APS      | Abort Processor Status. The value of the contents of location 252. This value is normally the processor status during the KT11-C Abort/Trap Service Routine.   |
| IPC      | Interrupt Program Counter. The value contained in the interrupt trap vector location; the starting address of the interrupt service routine.   |
| IPS      | Interrupt Processor Status. The value contained in the interrupt trap vector location plus two; the processor status to be set upon servicing the interrupt.   |
| IR6      | Interrupt Register 6. Value of the stack pointer for the interrupt service routine; either the Kernel, Supervisor, or User R6 and is specified by bits (15:14) of the IPS.   |
| KR6      | Kernel Register 6. The value of the stack pointer when the processor is in Kernel mode.  |
| PPC      | Program Program Counter. The value placed on the Kernel stack when the KT11-C causes an abort. If the abort was caused by an interrupt, then the PPC is the location of the next instruction to be executed when control is returned to the program that was interrupted. If the abort was caused by an instruction reference, then the PPC is equal to two more than the value of the last I space reference. In the latter case, the PPC will not be used for any computation. |
| PPS      | Program Processor Status. Value equal to the contents of the PS at the time of KT11-C abort that is placed on the Kernel stack.  |
| PR6      | Program Register 6. Value of the stack pointer for the "program". Note that PR6 may be KR6 if the program was in Kernel mode. If the program was in Supervisor mode, PR6 is the Supervisor R6; if the program was in User mode, PR6 is the User R6.  |

#### 2.4.10.2 Program Example

;NOTE THAT REGISTER SET 1 IS ASSUMED TO BE IN USE FOR BOTH THE USER AND KERNEL  
;MODES.

```

START:  MFPD   R6                ;PUSH PR6 ONTO KERNEL STACK
        MOV   R5, -(R6)         ;PUSH R5-R0 ONTO KERNEL STACK
        MOV   R4, -(R6)
        MOV   R3, -(R6)
        MOV   R2, -(R6)
        MOV   R1, -(R6)
        MOV   R0, -(R6)

        BIT   #140000, @ #177572 ;TEST FOR NON-RESIDENT OR PAGE
                                           ;LENGTH ABORT

        BEQ   +6
        JMP   ERROR            ;WAS SOMETHING OTHER THAN NON-RESIDENT
                                           ;OR PAGE LENGTH ABORT.

```

(continued on next page)

;“ERROR” ROUTINE IS NOT DESCRIBED IN THIS EXAMPLE. INSERT CODE HERE TO FIND A FREE  
;MEMORY BLOCK AND PULL THE PAGE INTO MEMORY FROM DISK OR DRUM SYSTEM. ASSUME  
;THE SUBROUTINE LEAVES THE PAR IN R1, THE PAR ADDRESS IN R2, THE PDR IN R3, AND THE  
;PDR ADDRESS IN R4.

```
MOV    R1, @R2           ;SET UP PAR OF NEW PAGE
MOV    R3, @R4           ;SET UP PDR OF NEW PAGE
```

;THIS CODE TESTS FOR WHETHER THE ABORT WAS CAUSED BY AN INSTRUCTION ACCESS OR BY  
;AN INTERRUPT ACCESS.

```
TSTB   @#177572         ;TEST INSTR. COMP. BIT OF SR0.
BPL    NORM             ;IF NOT SET, GO TO NORMAL RECOVERY
                           ;ROUTINE.
```

;THE FOLLOWING CODE OBTAINS LOCATION OF INTERRUPT TRAP VECTOR

```
MOV    @#177576, R3     ;MOVE KT11-C SR2 (THE TRAP VECTOR ADDRESS)
                           ;TO R3
MOV    2 (R3), R4       ;MOVE CONTENTS OF TV + 2 (THE TV PS) TO R4
BIT    #140000, R4      ;TEST BITS 15:14 OF IPS FOR 0 (=KERNEL MODE)
BEQ    KERNEL           ;IF KERNEL MODE, GO TO KERNEL ROUTINE.
```

;THE FOLLOWING ROUTINE OBTAINS THE STACK POINTER (IR6) OF THE SPACE THAT THE IPS IN  
;THE TV CALLED FOR. IF KT11-C SR1 HAS LOGGED CHANGES TO THIS R6, THEN IT WILL BE  
;CORRECTED. THE ROUTINE THEN PUTS THE PROGRAM PC AND PS (PPC AND PPS) CURRENTLY ON  
;THE KERNEL STACK ONTO THE STACK THAT IS CALLED FOR BY THE IPS; THUS PERFORMING THE  
;FIRST PART OF “EMULATING” THE INTERRUPT.

```
MOV    @#177776, R0     ;PSW TO R0
MOV    R0, R2           ;COPY PSW TO R2
BIC    #030000, R2      ;CLEAR OUT PREVIOUS MODE BITS IN COPY OF
                           ;THE PSW.
ASH    -2, R4           ;SHIFT THE NEW TV PS 2 PLACES RIGHT, PUTTING
                           ;THE TV PS CURRENT MODE BITS IN THE
                           ;PREVIOUS MODE POSITIONS.
BIC    #147777, R4      ;MASK OUT ALL BUT PREVIOUS MODE BITS IN
                           ;SHIFTED COPY OF IPS.
BIS    R4, R2           ;A NEW PS CREATED WITH CORRECT PREVIOUS
                           ;MODE IS NOW IN R2.
MOV    R2, @#177776     ;CHANGE PS SO WE CAN GET TO R6
                           ;SPECIFIED BY IPS.
MFPD   R6               ;GET PROPER R6
MOV    (R6)+, R2        ;POP R6 OFF KERNEL STACK, PUT IT IN R2
```

;THE FOLLOWING CODE CORRECTS THE PROPER R6, IF NECESSARY, TO ACCOUNT FOR THE  
;PUSHES OF THE PPC AND PPS ON THE STACK SPECIFIED BY THE IPS CURRENT MODE.

```
TST    @#177574         ;CHECK SR1 FOR AUTODECREMENT OF R6 IF IR6
BNE    ISOK             ;WAS ALREADY CHANGED. (ONLY POSSIBILITY
                           ;IS BY 4 BYTES.) IF SO, IT DOES NOT HAVE TO BE
                           ;CORRECTED.
SUB    #4, R2           ;DO THE AUTODECREMENT TO COPY OF IR6 IN R2
MOV    R0, R1           ;COPY APS INTO R1 SO THAT WE CAN DETERMINE
                           ;WHETHER PR6 IS IDENTICAL TO R6.
BIC    #147777, R1      ;LEAVE PMODE BITS OF APS (SPECIFYING MODE
                           ;OF PREVIOUS PROGRAM) IN R1.
XOR    R1, R4           ;TV MODE BITS IN R4
```

(continued on next page)

```

                BEQ     SAME                ;GO TO "SAME" IF PR6 = IR6.
                MOV     R2, -(R6)          ;PUSH COPY ONTO KERNEL STACK
                MTPD    R6                ;PUT CORRECTED IR6 BACK IN REGISTER.
                BR      ISOK              ;DONE WITH THIS PHASE
SAME:          SUB     #4, 14 (R6)        ;THE PR6 ON THE KERNEL STACK IS THE ONE TO
                ;BE CORRECTED.

```

;THIS CODE PUSHES THE PPC AND PPS, NOW ON THE KERNEL STACK, ONTO THE STACK SPECIFIED  
;BY THE IPS (IR6)

```

ISOK:          MOV     16 (R6), -(R6)      ;PUSH PPC ONTO TOP OF KERNEL STACK
                MOV     22 (R6), -(R6)    ;PUSH PPS ONTO TOP OF KERNEL STACK
                MTPD    (R2)              ;PPS OFF KERNEL STACK
                ;AND PUSHED ON I STACK.
                MTPD    -(R2)             ;PDC OFF KERNEL STACK
                ;AND PUSHED ON I STACK.
                MOV     R0, #177776       ;RESTORE APS. GET CORRECT PMODE BITS BACK

```

;THE FOLLOWING CODE PUTS THE IPC AND IPS INTO THE KERNEL STACK IN THE LOCATIONS  
;PREVIOUSLY OCCUPIED BY PPC AND PPS. NOTE THE PMODE BITS IN THE TV PS MUST BE PROPERLY  
;SET FROM THE CMODE BITS OF THE PPS STILL ON THE KERNEL STACK.

```

                MOV     20 (R6), R0       ;PUT COPY OF PPS INTO R0
                ASH     -2, R0            ;RIGHT SHIFT PPS COPY PLACING CMODE BITS
                ;INTO PMODE POSITION.
                BIC     #147777, R0       ;LEAVE ONLY PMODE BITS IN R0
                MOV     2 (R3), 20 (R6)   ;PUT COPY OF IPS INTO KERNEL STACK WHERE
                ;PPS USED TO BE.
                BIC     #30000, 20 (R6)   ;CLEAR OUT PMODE BITS OF IPS.
                BIS     R0, 20 (R6)       ;SET IPS PMODE WITH VALUE FROM CMODE OF
                ;PPS.
                MOV     (R3), 20 (R6)     ;PC IN TRAP VECTOR REPLACES PC ON KERNEL
                ;STACK.

```

;THE FOLLOWING CODE RESTORES THE GENERAL REGISTERS

```

RESTUR:        MOV     (R6) +, R0        ;RESTORE R0--R5 FROM THE KERNEL
                MOV     (R6) +, R1        ;STACK
                MOV     (R6) +, R2
                MOV     (R6) +, R3
                MOV     (R6) +, R4
                MOV     (R6) +, R5
                MTPI    R6                ;RESTORE R6 TO USER R6

```

;RESET STATUS REGISTER SR0, RETURN

```

RETURN:        MOV     #000001, @#177572 ;CLEAR SR0, SET KT11-C ON.
                RTI     ;RETURN

```

;IF IT WAS KERNEL, ONLY NON-FATAL ERROR COULD BE TV NON-RESIDENT. THEREFORE, R6  
;COULD NOT HAVE BEEN CHANGED BY THE INTERRUPT. THE FOLLOWING CODE POPS R0--R6 OFF  
;KERNEL STACK AND PUTS IPC AND IPS ON STACK.

```

KERNEL:        MOV     (R6) +, R0        ;POP R0--R6
                MOV     (R6) +, R1
                MOV     (R6) +, R2
                MOV     (R6) +, R3
                MOV     (R6) +, R4
                MOV     (R6) +, R5

```

(continued on next page)

```

MOV    @#177576, (R6)      ;ITV WRITTEN OVER OLD KR6.
MOV    @(R6), -(R6)       ;PUSH COPY OF CONTENTS OF ITV ON STACK
                                ;(IPC).
ADD    #2, 2 (R6)         ;ITV + 2
MOV    @2 (R6), 2 (R6)    ;REPLACE ITV + 2 WITH IPS

```

;THE FOLLOWING CODE TESTS FOR AN AUTODECREMENT OR AUTOINCREMENT OF KERNEL R6.  
;IF ONE IS DETECTED, CONTROL PASSES TO WAS6 WHICH CANNOT RESTART THE INSTRUCTION.

```

NORM:  MOV    @#177776, R3      ;GET PS TO R3
        BIT    #030000, R3     ;TEST FOR PREVIOUS KERNEL MODE
        BNE   CORECT          ;WAS NOT KERNEL
        MOV    @#177574, R4     ;PUT SR1 IN R4
        BIC   #174370, R4     ;LEAVE REG #S IN R4
        CMPB  #6, R4          ;TST FOR KR6, LOW BYTE
        BEQ   WAS6
        SWAB  R4
        CMPB  #6, R4          ;TST FOR KR6, HIGH BYTE
        BEQ   WAS6

```

;THE FOLLOWING CODE CORRECTS REGISTERS AUTOINCREMENTED OR AUTODECREMENTED  
;DURING INSTRUCTION THAT CAUSED ABORT. THIS CODE IS NOT USED WHEN AN INTERRUPT  
;CAUSED THE ABORT.

```

CORECT: MOV    #177574, R2      ;ADDRESS OF SR1
        MOV    #2, R3
LOOP1:  MOVB   (R2) +, R0       ;PUT CONTENTS OF SR1 IN R0, STEP ADDRESS
        BEQ   DONE            ;NO REGISTER CHANGED
        MOV   R0, R1          ;COPY SR1 INTO R1
        BIC   #177770, R1     ;MASK ALL BUT REGISTER #
        ASL   R1              ;MULTIPLY REGISTER # TO GET CORRECT INDEX
                                ;INTO STACK WHERE REGISTER IS TEMPORARILY
                                ;STORED.
        ASH   -3, R0          ;RIGHT JUSTIFY CORRECTION CONSTANT
        ADD   R6, R1          ;CREATE POINTER TO REG ON STACK
        ADD   R0, (R1)
        SOB   R3, LOOP1      ;BRANCH FOR SECOND CORRECTION

```

;CODE TO RESTORE PROGRAM COUNTER

```

DONE:   MOV    @#177576, 16 (R6)
        BR    RESTUR

```

#### 2.4.11 Fatal System Errors

The PDP-11/45 hardware design employs many safeguards that facilitate its use in reliable real-time and time-shared operating systems. These safeguards either prevent careless programmers from causing fatal system errors or allow the operating system to recover from the program fault. However, certain restrictions apply to system error, or "exception" handling. All facilities for handling interrupts with priority greater than processor priority 7 must be resident, meaning that for each of the fault types below the trap vectors, the appropriate stack and the service routine must all be resident. Otherwise, a fatal system error loop may occur that can only be intercepted from the console.

| Service Routine                  | Trap Vector |
|----------------------------------|-------------|
| Old Address                      | 4           |
| Fatal Stack Violation (Red)      | 4           |
| KT11-C Abort                     | 250         |
| Non-existent Memory Timeout      | 4           |
| Parity Error                     | 4           |
| Warning Stack Violation (Yellow) | 4           |
| Power Fail                       | 24          |
| FP11 Exception Trap              | 224         |

This restriction is necessary because: if, during the initial processing of a KT11-C abort any of these interrupts causes a second KT11-C abort, recovery will not be possible because the KT11-C can log status information in SR0, SR1, and SR2 for a single abort only. Until the information in SR0, SR1, and SR2 has been captured to handle the first abort, a second KT11-C abort must not occur.



# CHAPTER 3

## LOGIC DESCRIPTION

This chapter describes the KT11-C logic in sufficient detail that maintenance personnel can quickly determine the function and purpose of the logic circuits shown on the block schematics in the engineering drawings. Because the block schematics are drawn to show one or two functional sections of logic per sheet, the major paragraphs in this chapter follow the sequence of block schematic organization.

### 3.1 PDP-11/45 SYSTEM INTERFACE

In the PDP-11/45 system, the KT11-C Memory Management Unit is located between the KB11-A Central Processor Unit and the Fastbus, and Unibus A address lines (Figure 3-1).

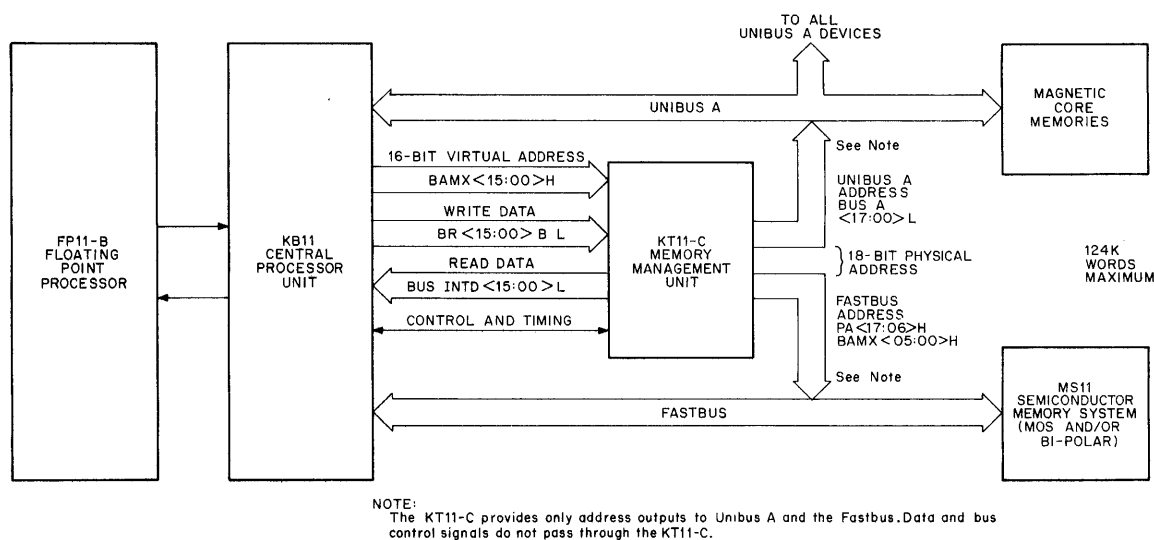

Figure 3-1 KT11-C System Hardware Interface

The processor provides a 16-bit virtual memory address to the memory management unit on the BAMX <15:00> H lines. These lines permit addressing a maximum of 32K word locations. The memory management unit adds the 13 least significant virtual address bits with 12 high order address bits obtained from internal page address registers to provide an 18-bit physical address that allows addressing up to 124K word locations in memory plus 4K locations in the I/O page. The method of physical address construction is described in Paragraph 2.1.1.

The 18-bit physical address is provided in two versions. The Unibus A address lines are BUS A <17:00> L. These outputs are used to address memories and devices connected to Unibus A. In addition, the 18-bit memory address formed by linking physical address bits PA <17:06> H and virtual address bits BAMX <05:00> H is output to the Fastbus; the high-speed MS11 Semiconductor Memory System is connected to the Fastbus.

Specific addresses are assigned to the internal Page Address and Page Descriptor Registers (PAR and PDR) so that page description and address data can be written into these registers under program control. The data inputs from the processor are BR <15:00> B L. These also provide the data inputs to some of the internal status registers. The contents of the PAR/PDR registers and the internal status registers can be read onto the processor internal data bus lines BUS INTD <15:00> L under program control.

## 3.2 KT11-C ORGANIZATION

Figure 3-2 is an overall block diagram of the KT11-C Memory Management Unit. The drawing reference within each block indicates the block schematic sheet that shows the associated logic. Only the major signal inputs and outputs are indicated on the overall block diagram. Complete circuit details are shown on the referenced block schematics.

### 3.2.1 System Address Path (SAP)

The upper half of the block diagram shows the flow of physical address generation, beginning with the BAMX <15:00> H inputs from the processor. This input is equivalent to the virtual memory address. The relocation logic links the virtual address with the contents of the page address field in the PAR to provide the physical address. Two versions of the physical address are available at the output. A Fastbus memory address that consists of PA <17:06> H and BAMX <05:00> H is provided for high-speed MOS and bipolar memories. The Unibus A memory address BUS A <17:00> L, provided for memory and devices, is derived from PA <17:00> H and BAMX <05:00> H. As indicated on the block diagram, most of the address path logic elements are located on the SAP module M8107.

### 3.2.2 Status and Control Logic

The lower half of the block diagram shows the status registers, timing logic, and control logic. Where possible, control and timing signals and data paths between the memory management unit and other major components of the PDP-11/45 system are indicated on the block diagram. Most of the status register and control logic elements are located on the System Status Registers (SSR) module M8108.

## 3.3 PAR/PDR REGISTERS

The PDP-11/45 Memory Management Unit uses three PAR/PDR sets. A set is provided for each mode: Kernel, Supervisor, and User. Each set consists of 32 16-bit registers, subdivided into two groups of 16. One group of 16 is used for references to Instruction (I) space and another group of 16 is used for references to Data (D) space. Each group is further divided into a set of eight Page Address Registers (PAR) and eight Page Descriptor Registers (PDR).

In hardware, each PAR is 12 bits wide and each PDR is 16 bits wide. A PAR and PDR are always used as a pair to provide a complete register pair that contains all the information required to describe and locate a current active memory page. The PAR/PDR organization is shown in Figure 2-6.



### 3.3.1 Page Address Registers (PAR)

Refer to drawings SAPA, SAPB, and SAPC. A PAR contains a 12-bit Page Address Field (PAF) that specifies the starting address of the page as a block number in physical memory. A set of 16 registers is provided for each mode: Kernel, Supervisor, and User. The 12-bit output of each set is ORed to the PAF <17:06> H lines. However, only one PAR set is enabled at any given time, depending upon which Chip Select input is asserted. Disabled PAR sets have their outputs “high”. Each PAR set is made up of three 3101A 16 × 4 bit memory chips, configured to provide 16 12-bit addressable registers. The Kernel PAR (KPAR) is shown on drawing SAPA, the Supervisor PAR (SPAR) is shown on drawing SAPB, and the User PAR (UPAR) is shown on drawing SAPC.

**3.3.1.1 Selection** – Only one PAR set is selected at a time. Selection is accomplished by asserting the Chip Select (CS) inputs. A PAR set is selected in either of two ways: by addressing one of the registers within the set or by operating in the mode associated with the set. Internal register decode logic shown on drawing SSRL provides the appropriate output if a register is addressed. The PAR addresses for Kernel, Supervisor, and User modes are charted on drawing SSRL. The Kernel/Supervisor/User address space control logic shown on drawing SSRB provides the appropriate Chip Select output in each operating mode. The SSRB KERNEL SPACE (1) L, SSRB SUPER SPACE (1) L, or SSRB USER SPACE (1) L output will be asserted depending upon the current or previous processor status, the current KB11 microstate, and other processor operating conditions described in Paragraphs 3.10.3 through 3.10.5.

**3.3.1.2 Addressing** – There are two ways to address one of the 16 registers within a selected PAR set.

1. **Virtual Memory Addressing:** The three most significant bits of the virtual address, plus a bit that tells whether the reference is I space or D space, are used to generate the address of a specific register.
2. **Internal Register Addressing:** When data is to be written into, or read from, a specific register of the selected PAR set, the five low order bits of the internal register address are used to generate address bits ADDR <3:0> and a “byte” select bit.

The most significant address bit, SAPA APR ADDR3K H, is used to specify the group of eight D space registers or the group of eight I space registers of the selected set. The source of address bits is summarized in Table 3-1.

**Table 3-1  
Address Bit Source**

| Access                | PAR Address Source |        |        |        |
|-----------------------|--------------------|--------|--------|--------|
|                       | ADDR3              | ADDR2  | ADDR1  | ADDR0  |
| Internal register     | BAMX04             | BAMX03 | BAMX02 | BAMX01 |
| Not internal register |                    |        |        |        |
| I SPACE               | 0                  | BAMX15 | BAMX14 | BAMX13 |
| D SPACE               | 1                  | BAXM15 | BAMX14 | BAMX13 |

The ADDR3 sources for each PAR set, Kernel, Supervisor, and User, are selected by a 74S158 shown on drawing SAPA. The I SPACE bit is generated by the address space control logic shown on drawing SSRB and described in Paragraph 3.10.6. The ENBL D inputs for Kernel, Supervisor, and User APR addresses are derived from Status Register 3 outputs. SR3 is shown on drawing SAPN and described in Paragraph 3.9. The specific address is decoded from the BAMX inputs by a 74S158 Line Selector shown on drawing SAPA. When the address is not that of an internal register, SSRL INT REG FAST L remains high and DAPD BAMX <15:13> H are selected. If an internal register address is decoded, SSRL INT REG FAST L is asserted and DAPB BAMX <03:01> H are selected.

**3.3.1.3 Writing Into a PAR** – With the Chip Select and address inputs asserted as described, data from the processor bus register, PDRB BR (11:00) B L, will be written into the addressed PAR when the Write (W) input goes low (Paragraph 3.15.3). The following conditions are required:

- a. TMCE C1 H – Asserted for all DATO or DATOB bus transactions.
- b. TMCE BEND H – Must be low. If asserted by bus, parity, or stack errors, or certain processor ROM states, the bus cycle will end.
- c. UBCC HI BYTE H and UBCC LO BYTE H – Asserted for all DATO bus transactions and for DATOB transactions coincident with byte address bit BAMX 00.
- d. SSRL KERNEL PAR (1) H – Asserted by any Kernel PAR address. If the address is that of a Supervisor or User PAR, the appropriate SSRL SUPER PAR (1) H or SSRL USER PAR (1) H level will be asserted (drawings SAPB and SAPC).

When the above conditions are valid, data on PDRB BR (11:00) B L is written into the selected PAR when timing pulse SAPC PULSE BC9 H goes high. This occurs at time T4 of the Pause or Long Pause Cycle.

**3.3.1.4 Reading From a PAR** – The contents of a specific PAR are available on the SAPA + B + C PAF (17:06) H output lines when that address is asserted and the appropriate Chip Select inputs go low. The KPAR, SPAR, and UPAR outputs are ORed to the same lines but only one set is enabled to provide the PAF (17:06) H page address. PAF (17:06) H can be selected as APR BIT (11:00) H inputs to the internal bus data lines (Paragraphs 3.7 and 3.14).

### 3.3.2 Page Descriptor Registers (PDR)

Refer to drawings SAPD, SAPE, and SAPF. A PDR is the second word of the 32-bit PAR/PDR set that describes each active page. A set of 16 registers is provided as the PDR for each mode: Kernel, Supervisor, and User.

Each PDR contains the 7-bit Page Length Field (PLF), two bits of access information (A and W), an Expansion Direction bit (ED), and a 3-bit Access Control Field (ACF). The significance of each PDR field and bit is described in Paragraph 2.2.2. The 16-bit output of each PDR set is collector-ORed to the same set of output lines; however, only one PDR set is enabled at any given time, depending upon the asserted Chip Select input.

Each PDR set comprises four 3101A 16 × 4 bit memory chips, configured to provide 16 16-bit addressable registers. The Kernel PDR (KPDR) is shown on drawing SAPD, the Supervisor PDR (SPDR) is shown on drawing SAPE, and the User PDR (UPDR) is shown on drawing SAPF.

**3.3.2.1 Selection** – There are three ways to select a PDR set:

- a. When the address of any PDR within that set is decoded.
- b. When the address of an associated PAR within that set is decoded.
- c. When the address space control logic shown on drawing SSRB asserts the appropriate space control signal. The SSRB KERNEL SPACE (1) L, SSRB SUPER SPACE (1) L, or SSRB USER SPACE (1) L output will be asserted depending upon the current microstate and other processor operating conditions described in Paragraphs 3.10.3 through 3.10.5.

**3.3.2.2 Addressing** – The APR addressing logic that asserts SAPA ADDR (3:0) H to select one of 16 registers within a selected PDR set is described in Paragraph 3.3.1.2

**3.3.2.3 Writing Into a PDR** – The PLF, ED, and ACF fields are written into each register of a PDR under program control in the same way a base address is written into each PAR. The timing and control conditions used to assert the W inputs to three of the 3101A chips are the same as those described in Paragraph 3.3.1.2. When these SAPA WR OK conditions are satisfied and the appropriate PDR is selected, data from the bus register will be written into the PLF, ED, and ACF fields on PDRB BR <15:08> B L and PDRB BR <03:00> B L.

**3.3.2.4 Setting A or W Bits** – Refer to drawing SAPD. Separate logic provides the W input to the 3101A that stores the A and W bits of each PDR set. SAPD WR A + W L is asserted during physical address generation if no internal register address is decoded, or if the decoded internal register is any PAR/PDR address and SAPA WR OK H conditions are satisfied.

The A bit is set if a memory management trap occurs during the access of the associated memory segment. The A bit is stored in the ATTN flip-flop. The W bit is set if a write cycle occurs during the access of the associated memory page. The W bit is stored in the WRTN INTO flip-flop. Once the A or W bit has been set, all subsequent access of that page causes the bits to be read out of the 3101A and clocked into the ATTN and WRTN INTO flip-flops at T5 of the Bust cycle. Then, at T4 of the Pause cycle, the contents of the ATTN and WRTN INTO flip-flops are written back into the 3101A. Note that any new information caused by the current memory access is ORed into the A and W bits at this time. The bits cannot be set if an abort occurs during the access or if an internal register is accessed.

**3.3.2.5 Clearing A or W Bits** – Whenever the physical address of the current memory reference is an internal register, SAPD ATTN DATA and SAPD WRTN DATA are not asserted. Thus, the A and W bits of a PDR are cleared by writing into either that PDR or the corresponding PAR of that pair.

**3.3.2.6 Reading From a PDR** – The KPDR, SPDR, and UPDR outputs are collector-ORed, but only the chip-selected PDR output will be available. The PAR/PDR read multiplexer that selects either PAR or PDR outputs is shown on drawing SAPM. Selection is controlled by virtual address bit VA05. When a PAR is addressed, SAPC VA05 B H will always be high and the PAF inputs will be selected as the PAR/PDR multiplexer output. If a PDR is addressed, SAPC VA05 B H will always be low and the PDR fields will be selected as the PAR/PDR multiplexer output.

## 3.4 RELOCATION LOGIC

### 3.4.1 Address Inverters/Buffers

The virtual address inverters/drivers are shown on drawing SAPH. They convert the 16 BAMX <15:00> H address inputs from DAPB, DAPC, and DAPD to virtual address outputs SAPH VA <15:00> B H. The 74S04 inverters are used to obtain inverted outputs SAPH VA <08:00> B L, required in the memory management.

### 3.4.2 12-Bit Adder

Refer to drawing SAPJ. The 12-bit adder consists of three 74S181 4-bit ALUs and a 74S182 Look-Ahead Carry Generator. The function select inputs (S3:S0) on the 74S181 are connected H L L H to perform the add function  $F = A \text{ plus } B$ . The mode control (M) inputs are connected low to select the arithmetic mode of operation.

The low order 74S181 ALU adds  $SAPA + B + C$  SAF <09:06> H to SAPH VA <09:06> B H to produce SAPJ ADRS <09:06> H. Fast simultaneous carry generation is performed by two cascade outputs, SAPJ ARIT AP H and SAPJ ARIT AG H. These are applied to the 74S182 Look-Ahead Carry Generator that generates the SAPJ COUT A L signal applied to the next 4-bit ALU.

SAPA + B + C SAF <13:10> H and SAPH VA <12:10> H are full-added, with carry input by the next 74S181 ALU. Because of the possibility of a carry output, the 74S182 Look-Ahead Carry Generator processes SAPJ ARIT BP H and SAPJ ARIT BG H. Output SAPJ COUT B L is added to SAPA + B + C SAF <17:14> H by a third 74S181 ALU to produce SAPJ ADRS <17:14> H.

Thus, the 7-bit block number of the virtual address VA <12:06> B H is added to the 12-bit base address provided by page address field bits PAF <17:06> H to provide SAPJ ADRS <17:06> H. These are the 12 most significant bits of the relocated physical address. Typical add time is 36 ns.

### 3.4.3 Relocation Multiplexer

Refer to drawing SAPJ. The relocation multiplexer consists of the three 74S157 Multiplexer chips, whose enable inputs are always enabled. The signal SSRE RELOC L is applied to the select inputs; therefore, when the KT11-C is in operation (Paragraph 3.10.8), the A inputs SAPJ ADRS <17:06> H are selected by the multiplexers to provide physical address bits SAPJ PA <17:06> H.

If the KT11-C is not enabled, SSRE RELOC L will be high and the multiplexers will select the B inputs as the physical address. Under non-operational conditions, BAMX <15:06> H provide physical address bits PA <15:06> H directly from the central processor. The two most significant bits of the address PA <17:16> are provided by DAPD EX MEM FLAG H. This forces PA <17:16> to be asserted when BAMX <15:13> are asserted (an I/O address). Otherwise, PA <17:16> will not be asserted.

## 3.5 CONSOLE ADDRESS DISPLAY AND CONTROL

### 3.5.1 ADDRESS Display

The sources of the ADDRESS display bits SAPK DISP ADR <17:00> H are shown on drawings SAPH, SAPJ, and SAPK. Figure 3-3 is a simplified diagram of the ADDRESS source.

ADDRESS display bits SAPK DISP ADR <05:00> H are not affected by KT11-C logic or console Address Display Select switch positions. The source of these bits is DAPB BAMX <05:00> H.

ADDRESS display bits SAPK DISP ADR <15:06> H depend upon the status of the KT11-C unit and the setting of the console Address Display Select switch. The source of SAPK DISP ADR <15:06> H for each condition of these variables is summarized in Table 3-2.

The source of ADDRESS display bits SAPK DISP ADR <17:16> H is determined by the KT11-C status, the console Address Display Select switch position, the console switches, and the DAPD EX MEM FLAG H signal. The source of SAPK DISP ADR <17:16> H for each condition is summarized in Table 3-2.

### 3.5.2 Console Mode Control

The Console Address Display Select switch performs mode and space select functions, in addition to ADDRESS display selection (Paragraph 3.5.1). UBCJ DIS ADRS SEL <2:0> H inputs from the console are decoded by a 7442 Decoder (drawing SSRK). The outputs are used with ROM OUT12 to set the appropriate space control flip-flops under console control conditions (Paragraphs 3.10.3 through 3.10.6).

## 3.6 ABORT AND TRAP DECODE

Drawing SAPL shows the abort and trap decode logic. The abort control logic is also shown on SSRK; the memory management trap control logic is located on the SSR module and shown on drawing SSRD. Paragraph 3.11.2 is a detailed description of the trap control logic. A KT11-C abort causes a processor interrupt that is

vectored through Kernel virtual address location 250 in D space. The abort is caused by one of four types of illegal memory references. If one of these is detected by the abort decode logic, the memory reference is not completed and the processor traps immediately to location 250 in Kernel D space.

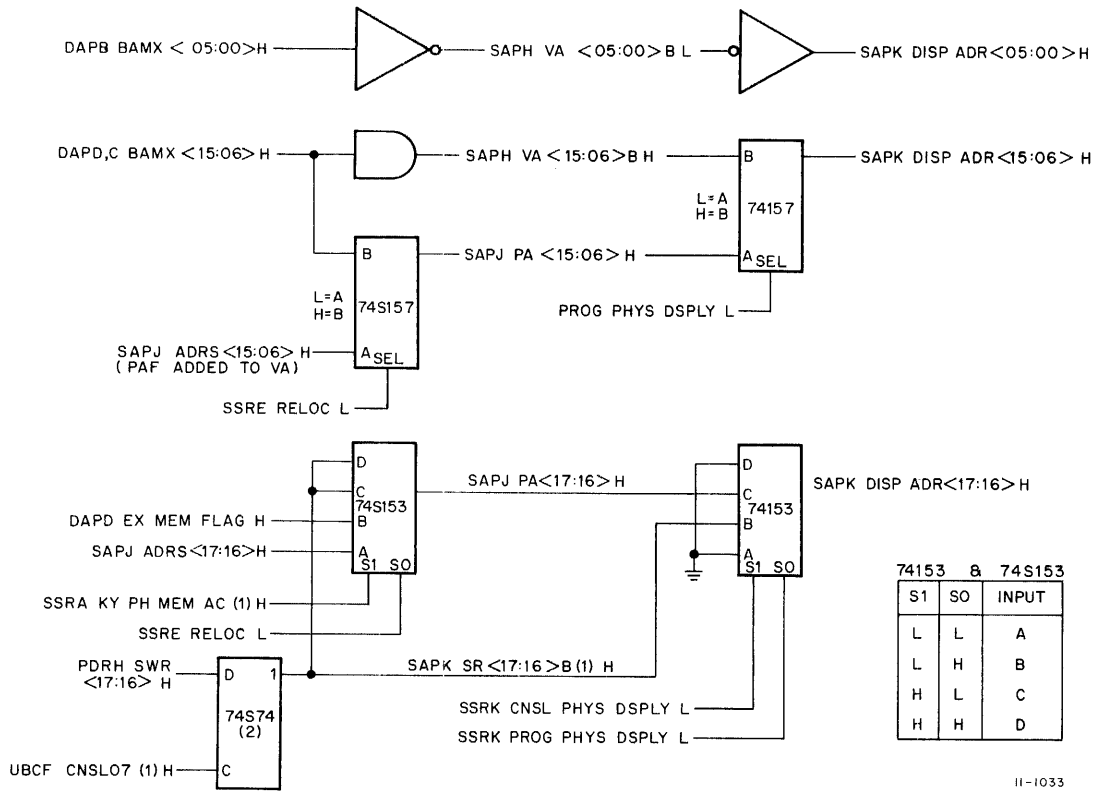

Figure 3-3 Sources of ADDRESS Display, Simplified Diagram

Table 3-2  
Address Display Sources

| Address Display Select Switch | KT11-C Enabled | Source of ADDRESS Display Bits |                         |                         |
|-------------------------------|----------------|--------------------------------|-------------------------|-------------------------|
|                               |                | $\langle 17:16 \rangle$        | $\langle 15:06 \rangle$ | $\langle 05:00 \rangle$ |
| PROG PHY                      | No             | EX MEM FLAG*                   | BAMX                    | BAMX                    |
| PROG PHY                      | Yes            | PA                             | PA                      | BAMX                    |
| CONS PHY                      | No             | SWR                            | BAMX                    | BAMX                    |
| CONS PHY                      | Yes            | SWR                            | BAMX                    | BAMX                    |
| KERNEL, I or D                | No             | 0                              | BAMX                    | BAMX                    |
| SUPER, I or D                 | Yes            | 0                              | BAMX                    | BAMX                    |

\* EX MEM FLAG = BAMX  $\langle 15*14*13 \rangle$  H

The four categories of illegal memory references that will cause an abort are:

- a. Non-Resident Page – Any attempt to access pages with ACF keys = 0, 3, or 7 causes an abort.
- b. Read-Only Page – Any attempt to write into pages with ACF keys = 1 or 2 causes an abort.
- c. Page Length Error: Address Too Low – If the page expansion direction is down and the block number is lower than the PLF, the address is too low and an abort occurs.
- d. Page Length Error: Address Too High – If the page expansion direction is up and the block number is higher than the PLF, the address is too high and an abort occurs.

### 3.6.1 Abort Control Logic

The following paragraphs describe the abort decode logic used to detect these types of illegal memory references. The abort flags that identify each type of abort condition are part of SR0 (drawing SSRC).

**3.6.1.1 Non-Resident (NR) Page Fault** – The non-resident page keys are 0, 3, and 7. The ACF bits are decoded to produce  $SAPL\ KEY = 0\ L$  or  $SAPL\ KEY = 3 + 7\ L$ . Either output asserts  $SAPL\ NON\ RES\ FAULT\ L$ , which is one of the inputs that asserts  $SAPL\ ABORT\ COND\ H$ . Note (drawing SSRC) that  $SAPL\ NON\ RES\ FAULT\ H$  will be written into SR0 bit 15 as an indication of the cause of the abort.

**3.6.1.2 Resident Read-Only (RRO) Fault** – The RROT (resident read-only and trap) key is 1. The RRO (resident read-only) key is 2. If either key is decoded from the ACF and  $SAPL\ WRITE\ CYCLE\ H$  is high, a resident read-only fault is detected and  $SAPL\ READ\ ONLY\ FAULT\ H$  asserts  $SAPL\ ABORT\ COND\ H$ . Note, on drawing SSRC, that  $SAPL\ READ\ ONLY\ FAULT\ H$  will be written into SR0 bit 13, as an indication of what caused the abort. Also,  $SAPL\ WRITE\ CYCLE\ H$  will be asserted for either a DATO or DATIP bus cycle.

**3.6.1.3 Page Length Fault** – Two 7485 Comparators, shown on drawing SAPL, perform a high-speed comparison of the 7-bit block number,  $VA\ \langle 12:06 \rangle\ B\ H$  and the 7-bit page length field  $PLF\ \langle 06:00 \rangle\ H$ , which is the authorized page length. The following subparagraphs expand on the page length examples presented in Paragraph 2.2.2.5 to explain the logic.

- a. Address Too High – Refer to Figure 2-9. Assume the expansion direction is up ( $ED = 0$ ) and the authorized page length is  $42_{10}$  blocks. The number in the PLF will be set to  $51_8$  ( $41_{10}$ ), which is the highest block number that can be accessed. If the block number,  $VA\ \langle 12:06 \rangle\ B\ H$ , is greater than the PLF, comparator output  $A > B$  will go high, asserting  $SAPL\ PLF < VA$ . This signal is NANDed with  $SAPD\ PGE\ EXPN\ DOWN\ L$  to produce  $SAPL\ ADRS\ TOO\ HIGH\ L$ .
- b. Address Too Low – Refer to Figure 2-10. Assume the expansion direction is down ( $ED = 1$ ) and the authorized page length is  $42_{10}$  blocks. The number in the PLF will be set to  $126_8$ . If the block number,  $VA\ \langle 12:06 \rangle\ B\ H$ , is less than the PLF, comparator output  $A < B$  will go high, asserting  $SAPL\ VA < PLF$ . This signal is NANDed with  $SAPD + E + F\ PGE\ EXPN\ DOWN\ H$  to produce  $SAPL\ ADRS\ TOO\ LOW\ L$ .

### 3.6.2 Internal Register Inhibit

The abort conditions decoded as described in Paragraph 3.6.1 are ORed to produce the  $SAPL\ ERROR\ H$  signal. Signal  $SAPL\ ERROR\ H$  goes to the D input of the INHIBIT flip-flop on drawing SSRK. This flip-flop is clocked at T4 of the Bust part of every memory cycle that is relocated. The flip-flop is cleared by either INIT or by doing an examine or deposit with the console Address Select switch in either “Program Physical” or “Console Physical” position. Thus, any abort condition asserts  $SSRK\ INHIBIT\ (1)\ L$ , which prevents any internal register selection flip-flop from being clocked. Refer to the internal register control logic shown on drawing SSRL.

The SSRK INHIBIT flip-flop is required for proper operation of the internal register logic on SSRL when the RC processor clock is set very slow (more than 1  $\mu$ s/time state) for maintenance purposes.

### 3.6.3 Memory Management Trap Decode

The decode logic for memory management trap conditions is also shown on drawing SAPL. The memory management trap conditions are specified by the ACF keys as listed in Table 2-2. These conditions are summarized as follows:

- a. Trap any attempt to read if the ACF key is 1.
- b. Trap any attempt to write if the ACF key is 5.
- c. Trap any access attempt if the ACF key is 4.

When any of these conditions is decoded, SAPL MEM MGMT H is asserted. The resulting output is sent to the memory management trap control logic located on the SSR module (Paragraph 3.11.2).

### 3.7 PAR/PDR READ MULTIPLEXERS

Refer to drawing SAPM. The purpose of the PAR/PDR read multiplexers is to select either the Page Address Register or the Page Descriptor Register as the output that is applied to the internal bus data multiplexers shown on drawing SSRJ. The PAR/PDR read multiplexers consist of four 74S157s that are always enabled.

One of 16 PARs or PDRs will be read, depending on the internal register address. The only difference in addresses of a specific PAR/PDR pair is bit VA05. When VA05 is high, a PAR is addressed and the B inputs to the multiplexers are selected as the SAPM PAR/PDR BIT (15:00) H output. When a PDR is addressed, VA05 is low and the A inputs are selected.

### 3.8 UNIBUS ADDRESS DRIVERS

The Unibus A address drivers are shown on drawing SAPN. These drivers are enabled by the UBCA CPBSY B H signal from the processor Unibus control logic. The 18-bit Unibus A address output, BUSA A (17:00) L, is made up of physical address bits SAPJ PA (17:06) H and virtual address bits DAPB BAMX (05:00) H. The relocation logic provides SAPJ PA (17:06) H. The relocation logic provides SAPJ PA (17:06) H (Paragraph 3.4).

### 3.9 STATUS REGISTER 3 (SR3)

Refer to drawing SAPN. SR3 is a 4-bit register consisting of a 74S174 D-type flip-flop IC, located on the SAP module. The purpose and format of SR3 are described in Paragraph 3.4.5. The SR3 contents are applied to the APR address control logic shown on drawing SAPA. That logic is described in Paragraph 3.3.1.2.

SSRL INT SR3 (1) H is required to write data into SR3 and assert SSRL READ SR3 H, which gates the SR3 contents onto the processor internal data bus. The INT SR3 flip-flop is set when the SR3 address, 772516, is decoded.

### 3.10 KT11-C ROM AND DECODE

The KT11-C ROM includes four 74187 256  $\times$  4 Read-Only Memories. The ROM and associated decode logic is shown on drawing SSRA. The ROM effectively extends the processor ROM width by 16 bits. A chart that shows which processor microstates are affected by the ROM is contained on drawing SSRM. The KT11-C logic decodes the ROM output to control the operation of the memory management unit in coincidence with processor control operations. Several ROM bits control loading SR1 with autoincrement/decrement information. Seven ROM bits provide separation of I and D space accesses; other ROM bits provide miscellaneous control

### 3.10.1 ROM Organization

Each 74187 ROM provides 256 4-bit locations that are addressed by ROM address bits RACD RAR (07:00) H. Drawing SSRM is a chart that lists the processor microstate name associated with each location and indicates the ROM outputs that are asserted when each location is addressed. Thus, the chart represents a truth table for a 256 × 16-bit ROM, made up of the four 74187 ICs shown on drawing SSRA. For example, when the processor enters microstate D40.20, ROM location 121 is addressed by the RACD RAR (07:00) H inputs and ROM outputs 4, 5, and 7 are asserted. If D10.30 (122), D40.30 (131), or D10.40 (311) were addressed, these same ROM outputs are asserted. The bus transactions involved in these microstates appear identical to the KT11-C unit.

- ROM Output 4: Destination Mode
- ROM Output 5: BSOP1
- ROM Output 7: Bust Cycle

Thus, the KT11-C ROM augments the processor ROM outputs for any microstate that involves memory management. Table 3-3 lists the ROM function that is decoded from each ROM output, or combination of ROM outputs.

**Table 3-3**  
**ROM Output Decoding**

| SSRA ROM Outputs |   |   |   | ROM Output Asserted                                   | Function                                      |  |
|------------------|---|---|---|---|---|--|
|                  |   |   |   |   | Signal Derived                                | Purpose  |
|                  |   |   |   | <b>ROM IC #1 (23-C45A2)</b>                           |   |  |
| X                | 0 | 0 | 0 | None  | N/A   | No operation   |
| X                | 0 | 0 | 1 | SSRA ROM OUT1 H                                       | SSRA RESTORE PS (1) H                         | Forces processor to restore PS if abort occurs during trap sequence.                         |
| X                | 0 | 1 | 0 | SSRA ROM OUT2 H                                       | SSRA AUTO DEC (0) H<br>SSRA ONE CHANGED (1) H | Clears AUTO DEC flip-flop on SSRA to indicate increment. Sets ONE CHANGED flip-flop on SSRA. |
| X                | 0 | 1 | 1 | SSRA ROM OUT1 H<br>SSRA ROM OUT2 H                    | SSRA AUTO DEC (1) H<br>SSRA ONE CHANGED (1) H | Sets AUTO DEC flip-flop to indicate decrement. Sets ONE CHANGED flip-flop.                   |
| X                | 1 | 0 | 0 | SSRA ROM OUT3 H                                       | SSRA BRK.30 (1) H                             | Indicates processor is in BRK.30 microstate. Sets INSTR COMP flip-flop and clears SR2.       |
| X                | 1 | 0 | 1 | SSRA ROM OUT1 H<br>SSRA ROM OUT3 H                    | SSRA JSR.30                                   | Prevents destruction of processor register contents if an abort occurs during a JSR.         |
| X                | 1 | 1 | 0 | SSRA ROM OUT2 H<br>SSRA ROM OUT3 H                    | SSRA CLR 16 + 17 H                            | Clears SR16, SR17 flip-flops on SAPK following a START or CONTINUE.                          |
| X                | 1 | 1 | 1 | SSRA ROM OUT1 H<br>SSRA ROM OUT2 H<br>SSRA ROM OUT3 H | SSRA CLR PSR (1) H                            | Clears PS Restore flip-flop in FET.00 and BRK.00 microstates.                                |
| 1                | X | X | X | SSRA ROM OUT4 H                                       | SSRA DST (1) H                                | Provides maintenance facility.   |
|                  |   |   |   | <b>ROM IC #2 (23-C36A2)</b>                           |   |  |
| X                | X | X | 1 | SSRA ROM OUT5 H                                       | BSOP1   | Bus condition code is Bus Operation 1.   |

(continued on next page)

**Table 3-3 (Cont)**  
**ROM Output Decoding**

| SSRA ROM Outputs |    |    |    | ROM Output Asserted         | Function                |  |
|------------------|----|----|----|-----------------------------|-------------------------|--|
|                  |    |    |    |                             | Signal Derived          | Purpose  |
| 8                | 7  | 6  | 5  | ROM IC #2 (23-C36A2) (Cont) |                         |  |
| X                | X  | 1  | X  | SSRA ROM OUT6 H             | KERNEL DATI             | Bus transaction is Kernel mode DATI.   |
| X                | 1  | X  | X  | SSRA ROM OUT7 H             | BUST                    | Indicates BUST cycle.  |
| 1                | X  | X  | X  | SSRA ROM OUT8 H             | I IF MTP SPACE          | Forces I space if current instruction is MTPI or MFPI and both the current and previous modes are not both user. |
| 12               | 11 | 10 | 9  | ROM IC #3 (23-C35A2)        |                         |  |
| X                | X  | X  | 1  | SSRA ROM OUT9 H             | SSRB I SPACE ALWAYS     | Sets I SPACE flip-flop on SAPA if current microstate enters I space.   |
| X                | 1  | X  | X  | SSRA ROM OUT11 H            | I IF PREV = I           | Asserts SSRB I SPACE A L if previous memory cycle was I.   |
| 1                | X  | X  | X  | SSRA ROM OUT12 H            | I IF CNSL = I           | Asserts SSRB I SPACE A L if console operation selects I space.   |
| 16               | 15 | 14 | 13 | ROM IC #4 (23-C34A2)        |                         |  |
| X                | X  | X  | 1  | SSRA ROM OUT13 H            | I IF SRC F7             | Asserts SSRB I SPACE B L if instruction is source register 7.  |
| X                | X  | 1  | X  | SSRA ROM OUT14 H            | I IF DST F7 *-(MTP+MFP) | Asserts SSRB I SPACE B L if instruction is destination register 7 and not MT/FP space.                           |
| X                | 1  | X  | X  | SSRA ROM OUT15 H            | I IF DST F7             | Asserts SSRB I SPACE B L if instruction is destination register 7.   |
| 1                | X  | X  | X  | SSRA ROM OUT16 H            | I IF DST F7 and DST M2  | Asserts SSRB I SPACE B L if instruction is destination register 7 and destination mode 2.                        |

### 3.10.2 ROM OUT (4:1) Decoders

ROM outputs ROM OUT (4:1) H are decoded by two 74S157 Selectors used as high-speed decoders. When ROM F16 bit M2 is logic 0, the lower decoder is enabled and the upper decoder is disabled. ROM bit M1 is the select input. When it is logic 0, A inputs are selected; when M0 is logic 1, the SVC.70 function is decoded. When M1 is logic 1, B inputs are selected. Under these conditions, the autoincrement function is decoded when M0 is logic 0, and the autodecrement function is decoded when M0 is logic 1.

**NOTE**

Either autoincrement or autodecrement provides SSRA ONE CHANGED (1) H.

When ROM bit M2 is logic 1, the upper decoder is enabled and the lower decoder is disabled. M1 is the select input. When M1 is logic 0, A inputs are selected. Under these conditions, the BRK.30 (instruction complete) function is decoded when M0 is logic 0; when M0 is logic 1, the JSR.30 function is decoded. When M1 is logic 1, the decoder outputs are irrelevant.

The truth table for the ROM outputs is shown on drawing SSRA. The outputs are clocked into the 74175 flip-flops by SSRK PULSE 23 H, which occurs near the beginning of every processor microcycle (Paragraph 3.14).

The following paragraphs describe the functions of microstates decoded from the ROM OUT <4:1> outputs.

**3.10.2.1 RESTORE PS** – SSRA RESTORE PS (1) H is asserted only during processor microstate SVC.60. This is the Bust part of the push of the old PS onto the stack specified by the new PS during any trap or interrupt sequence. SSRA RESTORE PS (1) H is inverted and renamed SSRA SET PSR L. This output sets the PSR flip-flop at SVC.60. The PSR flip-flop remains set until SSRA CLR PSR (1) H is asserted, which occurs during the FET.00 or BRK.00 microstates. Thus, the PSR flip-flop is only set during the push of the old PS and PC onto the stack during a trap or interrupt. If a KT11-C abort occurs during either of these push attempts, the old PS and PC must be restored. The old PS is temporarily stored in the processor BR; the old PC is temporarily stored in the processor DR.

The purpose of SSRA PS RESTORE (1) H is to force the processor through microstates ZAP.10 through ZAP.30 and to enable clocking of the PS register in the processor. Refer to Flow Diagram 12 in the KB11-A drawing set. The old PS is restored to the PS register, and the old PC is restored to the PC register. PS RESTORE allows proper recovery from aborts on interrupt and trap sequences.

**3.10.2.2 SSRA JSR.30 (ROM <3:1> = 5)** – If an abort occurs during a JSR instruction, SSRA JSR.30 (1) H asserts SSRA INH PWE H (Inhibit Pad Write Enable), which prevents the processor from writing into the general registers. This function may be invoked if an abort occurs on the push of the destination register onto the stack during a JSR (microstate JSR.30) or if an abort occurs on the fetch of the new top of the stack (MRK.20).

At JSR.30 the old PC is normally written into the destination register thus destroying the destination register contents. SSRA INH PWE prevents this destruction. At MRK.20 the stack pointer, register 6, is normally modified by N (the MARK argument) + 2. SSRA INH PWE prevents this modification if an abort occurs at the new top of the stack. Signal SSRA JSR.30 allows proper recovery from aborts at JSR.30 and MRK.20 microstates.

**3.10.2.3 BRK.30 (ROM <3:1> = 4)** – The BRK.30 microstate is decoded from the ROM as an indication that the current instruction is complete and that some interrupt or trap memory reference is about to begin. BRK.30 (1) H is ANDed with SSRC NO ERROR H to set the INSTR COMP flip-flop (drawing SSRE).

**3.10.2.4 AUTO DEC (ROM <3:1> = 3)** – The AUTO DEC signal is decoded from the KT11-C ROM for any microstate in which autodecrementing a general register is required. The AUTO DEC signal controls the MSB of each SR1 byte and configures the 2's complement generator (Paragraph 3.12).

**3.10.2.5 ONE CHANGED (ROM <3:1> = 2 or 3)** – The ONE CHANGED flip-flop is set when any microstates in which autoincrement or autodecrement occurs is decoded from the KT11-C ROM. This flip-flop sets the ONE AUTOED flip-flop (Paragraph 3.12) for the purpose of clocking byte 0 and byte 1 of SR1. It is initially cleared so that the first general register that is “autoed” is described in byte 0 of SR1. ONE AUTOED is then set. If a second general register is autoed during the instruction, that general register description is loaded into byte 1 of SR1.

**3.10.2.6 DST – ROM OUT 4 H** indicates destination mode. When the current memory reference is the final reference of a destination calculation, ROM OUT 4 H is asserted. The microstates that provide ROM OUT 4 are listed on SSRB. The ROM OUT 4 H output controls the state of the DST flip-flop, which is clocked by TIGC TI L. This provides the “maintenance” facility that is used by certain memory diagnostic programs; it is not to be used for any other purpose.

### 3.10.3 Kernel Space Control

Refer to drawing SSRB. Four conditions select the KERNEL SPACE flip-flop:

- a. By doing an EXAM or DEP operation under console control.
- b. By SSRA ROM OUT6 H, indicating the Kernel DATI bus condition (trap, interrupt, or abort).
- c. By BSOP1 bus condition (SSRA ROM OUT5 H) if the instruction is a move to or from previous data space, and the previous processor mode was Kernel.
- d. If current processor mode is Kernel, the console is not active, and the instruction is not a BSOP1 transaction and not a move to or from previous data space.

Any of the above conditions qualifies the D input of the KERNEL SPACE flip-flop. It is clocked and reset to assert SSRB KERNEL SPACE (1) L at T1 of the Bust cycle.

### 3.10.4 Supervisor Space Control

Refer to drawing SSRB. The three conditions that select the SUPER SPACE flip-flop are similar to those that select KERNEL SPACE (Paragraph 3.10.3, a, c, and d). The SUPER SPACE flip-flop is qualified if:

- a. Selected by doing an EXAM or DEP operation under console control.
- b. Selected by BSOP1 bus condition if instruction is a move to or from previous data space, and the previous processor mode was Supervisor.
- c. Selected if current processor mode is Supervisor, the console is not active, and the current instruction is not a BSOP1 transaction and not a move to or from previous data space, and not a Kernel DATI.

When any of these conditions are true, the SUPER SPACE flip-flop asserts SSRB SUPER SPACE (1) L.

### 3.10.5 User Space Control

The only differences between User space control conditions and Supervisor space control are the processor status word bits and console control switch selections. Thus, the USER SPACE flip-flop is qualified if:

- a. Selected by doing an EXAM or DEP operation under console control.
- b. Selected by BSOP1 bus condition if instruction is a move to or from previous data space, and the previous processor mode was User.
- c. Selected if current processor mode is User, the console is not active, and the current instruction is not a BSOP1 and not a move to or from previous data space, and not a Kernel mode DATI.

### 3.10.6 I Space Control

Refer to drawing SSRB. The I space decoders assert I SPACE A L or I SPACE B L under the following conditions:

- a. SSRA ROM OUT8 H. I space is selected if the current instruction is a move to or from previous I space. IRCA IR 15 (1) L ensures D space (MTPD + MFPD).

(continued on next page)

- b. SSRA ROM OUT9 H. This ROM output is an unqualified request for I space. No other conditions are required to assert I SPACE A L. Used for instruction fetches.
- c. SSRA ROM OUT11 H. This output asserts I space if previous memory reference was I space. It is ANDed with the output of the PREV = 1 flip-flop, which stores the I space condition from the previous memory cycle. Used for continuation of DATIP bus cycles.
- d. SSRA ROM OUT12 H. This output asserts I space if I space is selected at the console control (SAPP CNSL I SPACE H asserted).
- e. SSRA ROM OUT13 H. This output asserts I space if the current instruction is source register 7 (DPCH SRC F7 L asserted).
- f. SSRA ROM OUT14 H. This output asserts I space if the current instruction is destination register 7 (SSRB DST F7 H), and if the instruction is not an MTP or MFP instruction.
- g. SSRA ROM OUT15 H. This output asserts SSRB I SPACE A L whenever the destination register is 7.
- h. SSRA ROM OUT16 H. This output asserts SSRB I SPACE A L whenever the destination mode is 2 and the destination register is 7. It is used only for the special Floating Point immediate construction.

The I space control logic (drawing SSRB) is required to provide high-speed memory management throughput because there is a lack of direct association of I space for each specific microstate. SSRB I SPACEA L and SSRB I SPACEB L are used to set the I SPACEA and I SPACEB flip-flops (drawing SAPA) during T1 of the Bust cycle. This logic minimizes the delay required to generate the most significant PAR/PDR address bit, which determines whether an I space or D space PAR/PDR set is addressed.

### 3.11 STATUS REGISTER 0 (SR0)

The contents and format of SR0 are described in Paragraph 2.3.1. The SR0 bits and control logic are shown on drawings SSRC, SSRD, and SSRE. The SR0 format is shown in Figure 2-10.

#### 3.11.1 Abort Flags SR0 <15:13>

Refer to drawings SAPL and SSRC. SR0 bits 15, 14, and 13 are the memory management abort flags that indicate the cause of an abort. The fault detection logic is described in Paragraph 3.5 and shown on drawing SAPL. The fault signal outputs are SAPL NON RES FAULT H, SAPL PGE LENGTH FAULT H, and SAPL READ ONLY FAULT H. These inputs are applied to a 74157 Multiplexer at the B inputs. If not writing into the SR0, these inputs are selected as the data inputs to the 74175 flip-flops that store SR0 bits <15:13>.

SSRE STROBE OK L asserts SSRC STROBE ENABLE H when the following conditions are met:

- a. Not a BEND (processor will not complete memory cycle).
- b. No errors have been detected on previous memory references.
- c. The current memory reference is not accessing an internal register.
- d. KT11-C is enabled.

SSRE STROBE ENABLE H allows the fault information to be strobed into SR0 by the SSRK PULSE BC89 H clock pulse that occurs during the processor Pause cycle. The contents of SR0 <15:13> are ORed to the data input of the NO ERROR flip-flop, which is clocked by the SSRK PULSE BC910 L clock pulse. If no error flags are set, the NO ERROR flip-flop will remain set.

Data can be written into SR0 bits <15:13> under program control. Buffer register bits PDRB BR <15:13> B L are applied to the A inputs of the 74157. When SSRL WRITE SR0 REG H is asserted (Paragraph 3.5.1) and SAPH VA <02:01> B L indicate the SR0 address, the A inputs are selected as the data inputs to the SR0 flip-flops. The

data will be written into the SR0 when SSRK PULSE BC89 H occurs. In this case, SSRC STROBE ENABLE H is asserted by SSRE WRITE SR0 H and UBCC HI BYTE H.

#### NOTE

**Setting the SR0 error flags under program control does not cause an abort.**

The ABT FLG flip-flop (drawing SSRC) will only be set when the SAPL ABORT COND H signal is asserted and no internal register accesses are in progress. The state of SR0 bits 15, 14, 13 has no effect on the ABORT FLAG.

Figure 3-4 is a simplified diagram that depicts the KT11-C logic and how it interacts with the KB11-A logic to force a trap to Kernel D space location 250 when an abort condition is detected. The signal mnemonic prefixes indicate where each signal is generated in the two units. Refer to the KB11-A drawings for more complete details.

### 3.11.2 Memory Management Trap (SR0 Bit 12)

The memory management trap control logic is shown on drawing SSRD. The decode logic that detects trap conditions is shown on drawing SAPL and described in Paragraph 3.6.4. Figure 3-5 is a simplified diagram that shows the KT11-C trap control logic and the interaction with the KB11-A trap control logic.

**3.11.2.1 Enable Management Traps** – The ENABLE MGMT flip-flop (SR0 bit 09) must be set by program control. This is accomplished by writing into the SR0 with data bit BR09 on a logic 1. The SSRD DATA 09 H input is clocked into the ENABLE MGMT flip-flop by SSRE SR0 HIB CLK L, which is produced when T3 occurs during the Pause cycle.

Several other conditions must be satisfied before a memory management trap can occur. These are:

- a. SSRE RELOC H must be asserted, indicating the KT11-C is enabled.
- b. The bus transaction has not been terminated by Bus End (BEND).
- c. No internal register is being accessed.
- d. No abort occurred during the memory access.

**3.11.2.2 Pre-Management Trap** – If the conditions specified in 3.11.2.1 are satisfied and one of the three memory management trap conditions is decoded (Paragraph 3.6.4), SSRD PRE MGMT TRAP H is asserted. Because the MEM MGMT TRAP DETECTED flip-flop is initially cleared, the MGT TP DET DLY L signal is high at this time. As a result, SSRD CUR FLT L causes SSRD MEM MGMT TRAP L to be asserted. This is the trap signal that is sent to the processor. The same conditions that caused SSRD MEM MGMT TRAP L to be asserted allow the MEM MGMT TRAP DETECTED flip-flop to be direct-set when clock pulse SSRK PULSE BC89 H occurs. SSRD PRE MGMT TRAP H guarantees that a trap will be executed on the last memory reference of an instruction, before the next instruction is started.

**3.11.2.3 Memory Management Hold** – When SSRK PULSE BC89 H occurs, SSRD MEM MGMT B H is asserted. SSRD MGT TP DET DLY L will remain high for 50 ns. Thus, a 50-ns SSRD SET MGMT HOLD L pulse is produced to direct-set the MEM MGMT HOLD flip-flop. The purpose is to maintain the SSRD MEM MGMT TRAP L signal to the processor until it is acknowledged. Because traps are not handled by the processor until the end of an instruction, several memory references may occur before the processor sends TMCA SEG ACKN L, which clears MEM MGMT HOLD. Once the MEM MGMT TRAP DETECTED flip-flop (SR0 bit 12) is set, it will not cause another trap until it is cleared, even though additional trap conditions may be detected. It is normally cleared under program control by writing a 0 into bit 12 of SR0.





**3.11.2.4 Writing Into SR0 Bit 12** – The MEM MGMT TRAP DETECTED flip-flop can be set or cleared under program control by writing into the SR0 with data bit SR12 on a 1 or 0. SSRD DATA 12 H is clocked into the flip-flop by SSRD SR0 HIB CLK L. Because SSRD PRE MGMT TRAP H and SSRD MEM MGMT B L are not asserted, no memory management trap will occur.

### 3.11.3 Trap Flag (SR0 Bit 11)

The TRAP flip-flop (SR0 bit 11) is shown on drawing SSRD. The flip-flop is direct-set by the TRAP L input. The MEM MGMT HOLD flip-flop is set by the positive-going edge of the TRAP L signal. As a result, the SSRD MEM MGMT TRAP L signal is sent to the processor. The memory management trap service routine must interrogate the SR0 to determine whether the trap was caused by an access code violation detected by the KT11-C or by the trap flag.

The flag can be set or cleared under program control by writing into the SR0 with data bit BR11 set to 1 or 0. Setting the TRAP flip-flop under program control does not cause a memory management trap.

### 3.11.4 DST MODE (SR0 Bit 08)

Refer to the mode/status control logic shown on drawing SSRE. The DST MODE flip-flop (SR0 bit 08) is set or cleared under program control by writing into the SR0 with data bit BR08 set to 1 or 0. The data is clocked into the DST MODE flip-flop by SSRE SR0 HIB CLK L. This bit is set by program control during maintenance operations, which are performed with the RELOCATING flip-flop (SR0 bit 00) cleared. When the DST MODE flip-flop is set, the true output is ANDed with SSRA DST (1) H to assert the SSRE RELOC H signal. SSRA DST (1) H is decoded from the ROM when the final destination address is calculated. The purpose of this logic is to assert SSRE RELOC H only when the final address is calculated; thus, in the maintenance mode, only the final address is relocated and protected by the KT11-C unit.

#### NOTE

**SR0 bit 08 is used by the KT11-C diagnostic programs and is not to be used for any other purpose.**

### 3.11.5 INSTR COMP (SR0 Bit 07)

Refer to drawing SSRE, which shows the INSTR COMP flip-flop, SR0 bit 07. This bit indicates the status of each instruction. It is cleared at the beginning of each new instruction if the preceding instruction was executed without a page error. When the BRK.30 microstate is decoded at the ROM output, the INSTR COMP flip-flop is again set. Reaching the BRK.30 microstate implies that an interrupt is in progress and that the next memory reference will not be caused by an instruction. Setting the INSTR COMP bit in the SR0 provides the error handling routines with a means of determining whether the current instruction needs to be repeated in the course of recovering from an abort or whether some interrupt sequence will have to be emulated.

### 3.11.6 SR0 Mode Field (SR0 Bits <06:05>)

The SR0 mode field (bits 06 and 05) is shown on drawing SSRE. These bits are determined by the SSRB SR0 MODE (1:0) H D inputs to the 74175. The truth table for these inputs is:

| Space Mode Asserted     | SSRB SR0 Mode |   | SR0 Mode Field |
|-------------------------|---------------|---|----------------|
|                         | 1             | 0 |                |
| SSRB KERNEL SPACE (1) L | H             | H | 00             |
| SSRB SUPER SPACE (1) L  | H             | L | 01             |
| SSRB USER SPACE (1) L   | L             | L | 11             |
| None (Illegal)          | L             | H | 10             |

SR0 mode field 10 is illegal. Any attempt to access memory in that mode is aborted. Because no space is selected, the outputs of all PAR/PDRs are high. The ACF is therefore 111 (key = 7), an abort condition.

The SR0 mode field bits are clocked into the SR0 at the end of the Pause cycle by SSRK PULSE BC89 H if SSRE STROBE OK H is asserted. This only happens when:

- a. KT11-C is enabled.
- b. No BEND is issued by the processor.
- c. No internal register is involved.
- d. No paging error was detected on a previous bus cycle. If an error was detected, the mode field associated with the previous memory reference must be retained in SR0 (06:05) to aid in error recovery.

### 3.11.7 Address Space – I/D (SR0 Bit 04)

Refer to drawing SSRE. SR0 bit 04 indicates whether I or D space is being addressed. The bit is stored by one D-type flip-flop of a 74175. If I space is not addressed, SAPA IND DATA H is high at the input, and SR0 bit 04 will be set when clocked, indicating D space is addressed. The bit is clocked under the same conditions as described in Paragraph 3.11.6.

### 3.11.8 Page Number (SR0 Bits (03:01))

Refer to drawing SSRE. SR0 bits (03:01) are stored by three D-type flip-flops. The inputs are SAPH VA (15:13) H, which represent the page number being addressed. These bits are clocked as described in Paragraph 3.11.6.

### 3.11.9 KT11-C RELOCATING (SW0 Bit 00)

Refer to drawing SSRE. The KT11-C RELOCATING flip-flop (SR0 bit 00) is only set under program control by writing into the SR0 with data bit BR00 set to 1. Normally, setting SR0 bit 00 will assert SSRE RELOC H. The only exception is when performing a physical memory access from the console. Then, SSRA KY PH MEM AC (0) H goes low and inhibits SSRE RELOC H. This allows the address set on the console switches to address the physical unrelocated address.

#### NOTE

This bit essentially turns the KT11-C on and off.

## 3.12 STATUS REGISTER 1 (SR1)

Refer to drawing SSRF. Status Register 1 is a 16-bit register comprising four 74S174 D-type flip-flops. (Two flip-flops on each 74S174 are not used.) SR1 keeps track of any autoincrementing or autodecrementing of the general registers that may occur during the execution of instructions. The layout of SR1 is shown in Figure 2-12. When a general register is either incremented or decremented, the general register address GRAC GRA (2:0) B H and the number of bits by which the register was modified are stored in SR1. SR1 is divided into bytes 0 and 1. The low order byte (byte 0) is written first. SR1 is a read-only register; it cannot be written into under program control.

### 3.12.1 General Register Address

The general register address is available on inputs GRAC GRA (2:0) and is applied to the three low order bits of each byte in SR1. When the general register destination is in Register Set 1, GRAC GRA3 L is asserted and

SSRF GRA3 B H goes high. The purpose of this logic is to inhibit SSRF GRA0 B H if general register 17 (User mode Stack Pointer) is addressed. Thus, a reference to GRA17 is stored in Status Register 1, Register Number field as R6.

### 3.12.2 Autoincrement/Autodecrement

The constant that indicates the number of bits by which the general register was modified is available on inputs DAPD KOMX (03:00) B L. The KOMX constant multiplexer provides only constants 1, 2, 4, or 8; thus, only one of these inverted inputs will be logic 0 for any of these four constants. When the general register is decremented by a constant, the processor “subtracts” a positive constant. Therefore, the 2’s complement of the constant is generated by the KT11-C logic. The 74S157 Multiplexer is used as a 2’s complement generator for this purpose; the 74S157 is always enabled. During a decrement operation, SSRA AUTO DEC (0) H is low and the A inputs are selected to provide the 2’s complement of the constant. During an increment, SSRA AUTO DEC (0) H is high and the B inputs are selected to provide the constant as a positive binary number. Table 3-4 shows the constant multiplexer truth table for both decrement and increment outputs. The constant is input to bits SR1 (06:03) of byte 0 or SR1 (14:11) of byte 1. The SSRE AUTO DEC (1) H signal is input to SR1 as the MSB of each byte. This bit functions as a sign bit for each byte, indicating a decrement or an increment operation.

**Table 3-4**  
**Truth Table for Constant Multiplexer Outputs**

| Constant | DAPD KOMX B L |    |    |    | SSRA AUTO DEC (1) H |    |         |    | SSRA AUTO DEC (0) H |    |    |    |
|----------|---------------|----|----|----|---------------------|----|---------|----|---------------------|----|----|----|
|          | 03            | 02 | 01 | 00 | 02                  | 03 | 01 + 00 | 00 | 03                  | 02 | 01 | 00 |
| 1        | 1             | 1  | 1  | 0  | 1                   | 1  | 1       | 1  | 0                   | 0  | 0  | 1  |
| 2        | 1             | 1  | 0  | 1  | 1                   | 1  | 1       | 0  | 0                   | 0  | 1  | 0  |
| 4        | 1             | 0  | 1  | 1  | 1                   | 1  | 0       | 0  | 0                   | 1  | 0  | 0  |
| 8        | 0             | 1  | 1  | 1  | 1                   | 0  | 0       | 0  | 1                   | 0  | 0  | 0  |

### 3.12.3 Examples of SR1 Loading

As an example of SR1 loading, assume general register R5 is autoincremented by 2 in the source calculation of an instruction. SR1 is initially cleared by SSRH LOAD IR L. The ONE AUTOED flip-flop is also cleared. The general register R5 address is available at the GRAC GRA (2:0) inputs. The constant 2 is provided by DAPD KOMX 01 B L, and because the calculation is an increment, the 2’s complement of the constant is selected. Therefore, the information that is clocked into byte 0 of SR1 at time T5 is shown in Figure 3-6a. Further assume that general register R4 is autoincremented by 4 in the destination calculation of the instruction. The ONE AUTOED flip-flop is set when clock pulse SSRK PULSE 51 H occurs to provide SSRF CLK BYTE 1 H. Byte 1 of SR1 will be loaded as shown in Figure 3-6b at that time.

If an error occurs between the time one instruction is loaded (RACA UIRK H) and the time the next instruction is loaded or an interrupt is processed (BRK.30), SR1 has the general register modification information required to recover from the error. This information is available to the software recovery service routine.

Once the instruction is complete, no error has been detected, and an interrupt is being serviced, SSRA BRK.30 L and SSRC NO ERROR (1) H clear SR1 and the ONE AUTOED flip-flop. Any stack modification that occurs from that point until the next instruction fetch is recorded. There will be no need to restart the instruction, even if segmentation faults are detected before the next instruction fetch. Instead, the trap sequence has to be emulated to completion to recover and restart.

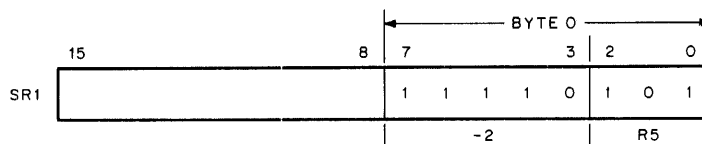

a. AUTO-DECREMENT R5 BY 2, SOURCE CALCULATION

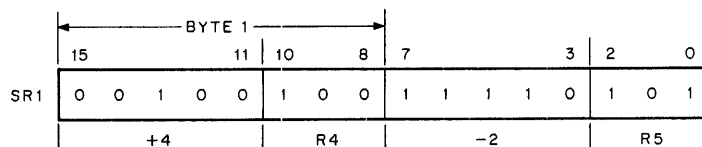

b. AUTO-INCREMENT R4 BY 4, DESTINATION CALCULATION

11-1035

Figure 3-6 Examples of SR1 Loading

### 3.13 STATUS REGISTER 2 (SR2)

SR2 consists of three 74174 D-type flip-flops (drawing SSRH). It is loaded with the 16-bit virtual address SAPH VA <15:00> B H at the start of each instruction fetch. Under these conditions, it stores the virtual address of each current instruction. It can also be loaded with the trap vector at the beginning of an interrupt or “T” bit, Parity, Odd Address, and Timeout traps. The clock input, SSRH NEW SEQUENCE CLK H, is produced by RACA UIRK H or the BRK.30 (0) L signal decoded at the KT11-C ROM output.

#### NOTE

SR2 is read only; it cannot be written into.

### 3.14 INTERNAL DATA BUS MULTIPLEXERS

The internal data bus multiplexers are made up of eight 74153 Multiplexers, shown on drawing SSRJ. The multiplexers are capable of selecting the contents of one of four registers as the 16-bit output to the processor internal data bus. The inputs are the APR, SR0, SR1, or SR2. The APR can be either the PAR or the PDR, depending upon the input selected by the PAR/PDR read multiplexer (Paragraph 3.7).

The specific register selected is determined by decoding virtual address bits BAMX <02:01>, the SSR REG flip-flop, and SSRL APR REG L. The input selection logic decodes this information as indicated in the following chart:

| SSRH BAMX |    | SSRL SSR REG (1) H | SSRL APR REG | Input |                  | Function Selected As Internal Data Bus Output |
|-----------|----|--------------------|--------------|-------|------------------|---|
| 02        | 01 |                    |              | S1    | S0               |   |
| 0         | 1  | 1                  | 0            | 0     | A: SR0 <15:00> H |   |
| 1         | 0  | 1                  | 0            | 1     | B: SR1 <15:00> H |   |
| 1         | 1  | 1                  | 0            | 0     | C: SR2 <15:00> H |   |
| *         | *  | 0                  | 1            | 1     | D: APR <15:00> H |   |

1 indicates assertion, 0 indicates non-assertion, \* indicates irrelevant.

The multiplexers are enabled when TMCE C1 H is asserted by the processor, provided that an internal register is addressed and the TCMF GET OFF H input is not asserted. At this time, data in the addressed register is available on the processor internal data bus lines, INT BUS DATA (15:00) H. The TCMF GET OFF input is only asserted for floating-point processor or switch register operations that use the same processor internal data bus lines.

### 3.15 KT11-C MEMORY MANAGEMENT TIMING

Timing for the KT11-C option is derived from KB11-A Central Processor time states TIGD TS (5:2) H (drawing SSRK). The processor time state inputs are not fixed but vary in length depending on the type of cycle through which the processor is progressing. Sample timing for the Bust and Pause memory cycles is shown in Figure 3-7. Note the memory management delay indicated on the diagram. The TIG module is normally jumpered to provide three time periods of delay. This is adequate for the KT11-C logic to complete its functions and allow the processor to continue through the Bust cycle.

#### 3.15.1 Event Times Related to Memory Cycles

Table 3-5 is a chart that shows how the KT11-C events relate to the KB11-A memory cycles and time states. The heavy lines indicate that an event occurs over an extended period of time. For example, the INT REG flip-flop remains cleared over the first half of T1. An asterisk indicates the possibility of an event if conditions other than timing are met. For example, if the BRK.30 microstate is decoded or the UIRK field of the current processor microstate is set to 1, SR1 will be cleared through the remainder of the memory cycle. The chart includes drawing references, indicating where the associated timing logic is on the block schematics.

#### 3.15.2 Address Relocation Timing

Figure 3-8 is a simplified diagram that shows the timing of the events that occur during page address relocation. The sequence of events is indicated by the numbered text boxes. Maximum time lapse for an event to occur is related to the leading edge of processor time state T1. Statements within rectangles apply to address relocation when the KT11-C is enabled, and a 16-bit virtual address is converted to an 18-bit physical address. Statements within ovals apply when the KT11-C is disabled (SR0 bit 00 = 0), and the 16-bit virtual address is passed through the KT11-C without change.

#### 3.15.3 Internal Register Access Timing

Figure 3-9 is a simplified diagram that shows the sequence of operations involved in a typical internal register access. The specific conditions assumed for this example are stated in the notes. Note that as soon as the KPAR contents are added to the virtual address and the resultant UPAR physical address is decoded, the D input of the User PAR flip-flop goes high. It is clocked at T5 of the Bust cycle, and SSRL INT REG FAST L is asserted. That signal de-selects the KPAR as shown. It is also sent to the processor in acknowledgement of a Fastbus address. All the KT11-C internal registers are Fastbus device addresses. Therefore, the KB11-A proceeds through a Fastbus memory cycle, not a Unibus cycle.

For a read (DATI) operation, the contents of the selected UPAR will be gated to the processor internal data bus (statements 8R and 9R on Figure 3-9). For a write (DATO) operation, the data from the processor BR will be written into the selected UPAR at T4 of the Pause cycle (statements 8W and 9W on Figure 3-9).

### 3.16 INTERNAL REGISTER CONTROL

The internal register address decode and control logic is shown on drawing SSRL.



Table 3-5  
How KT11-C Events Relate to KB11-A Memory Cycles

| CPU Cycle | Time State | PAR's & PDR's                             | Status Registers    |     |     |     |     |                          |     |     |                   |                   |     |     | Control Logic Timing |   |
|-----------|------------|---|---------------------|-----|-----|-----|-----|--------------------------|-----|-----|-------------------|-------------------|-----|-----|----------------------|---|
|           |            |   | SR0                 |     | SR1 |     | SR2 |                          | SR3 |     |                   |                   |     |     |                      |   |
|           |            |   | CLR                 | CLK | CLR | CLK | CLR | CLK                      | CLR | CLK | CLR               | CLK               | CLR | CLK |                      |   |
| BUST      | T1         |   |                     |     |     |     |     |                          |     |     |                   |                   |     |     |                      | Clear INT REG (SSRL). Clock 1 SPACE FF's (SAPA). Clock "SPACE" FF's (SSRB). Clock DST and KY PH MEM AC FF's (SSRB). |
|           | T2         |   |                     |     |     |     |     | *Clear SRI (SSRF) BRK.30 |     |     |                   |                   |     |     |                      | Clock ROMOUT 3:1 FF's (SSRA).   |
|           | T3         |   |                     |     |     |     |     |                          |     |     |                   |                   |     |     |                      |   |
|           | T4         |   |                     |     |     |     |     |                          |     |     |                   | *Clock SR2 (SSRM) |     |     |                      | Clock PREV=I (SSRB).  |
|           | T5         | Clock A and W FF's (SAPD)                 |                     |     |     |     |     |                          |     |     | *Clock SRI (SSRF) |                   |     |     |                      | Clock INT REG AND SEG FAST FF's (SSRL)  |
| PAUSE     | T1         |   |                     |     |     |     |     |                          |     |     |                   |                   |     |     |                      |   |
|           | T2         |   |                     |     |     |     |     | *Clear SRI (SSRF) LDIR   |     |     |                   |                   |     |     |                      | Clock ROMOUT 3:1 FF's (SSRA).<br>Clear "SPACE" FF's (SSRB)*.  |
|           | T3         |   | *Clear INST COMP FF |     |     |     |     |                          |     |     |                   |                   |     |     |                      |   |
|           | T4         | *Write Data into PAR's or PDR's. (SAPA-F) |                     |     |     |     |     |                          |     |     |                   |                   |     |     |                      |   |
|           | T5         |   |                     |     |     |     |     |                          |     |     |                   | *Clock SR2 (SSRH) |     |     | *Clock SRI (SSRF)    | *Clock SR3 (SAPN)   |
| (NEXT)    | T1         |   |                     |     |     |     |     |                          |     |     |                   |                   |     |     |                      | Clock NO ERROR (SSRC).  |

\*Indicates possible event; dependent upon conditions other than timing.



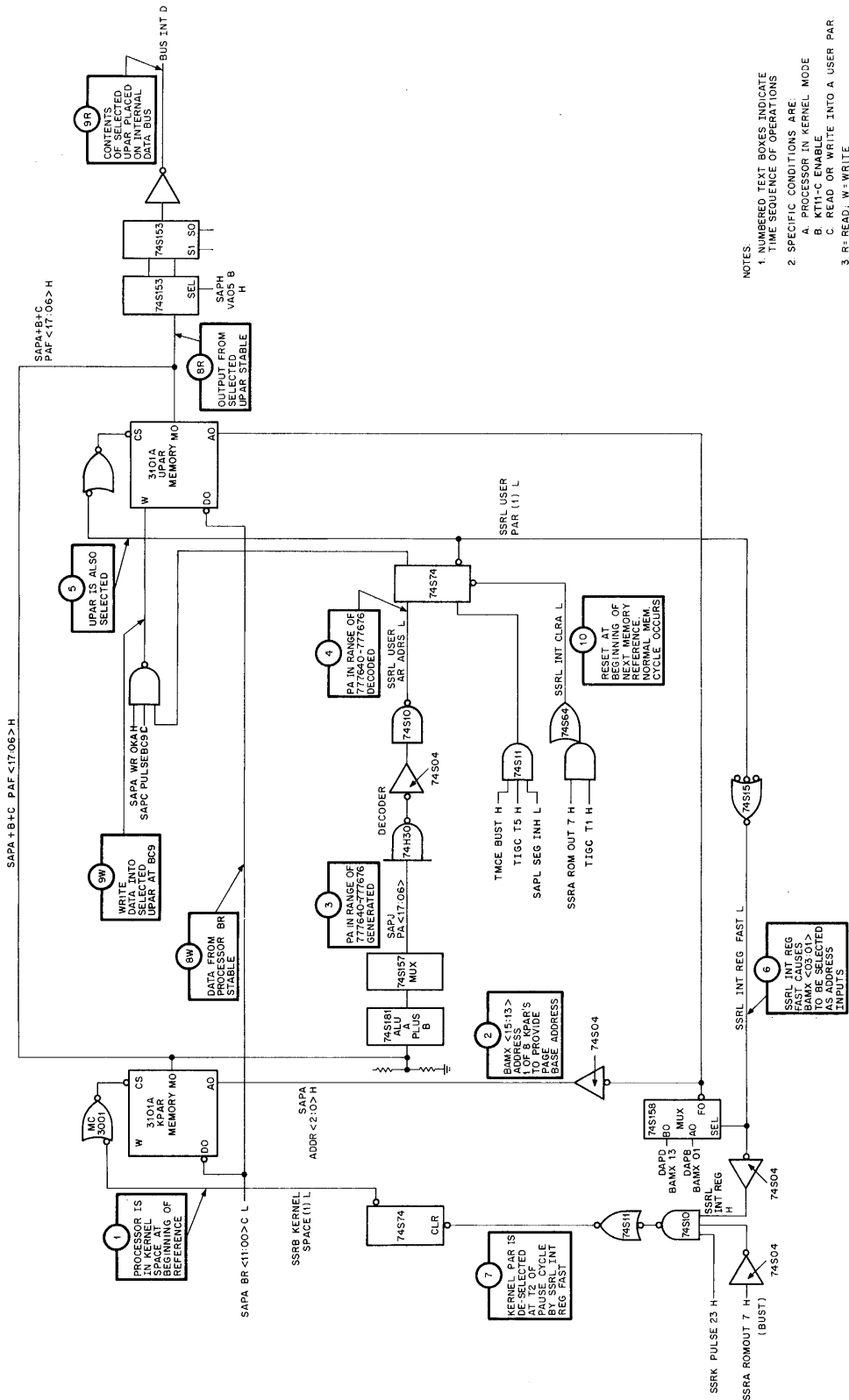

Figure 3-9 Internal Register Access Sequence, Simplified Diagram

### 3.16.1 PAR/PDR Decode and Control

On drawing SSRL, each address is decoded to determine whether one of the six PAR/PDR sets is being addressed. The address ranges of User, Supervisor, and Kernel PAR/PDR sets are tabulated on the drawing. Physical address bits PA (17:06) H and virtual address bits VA (05:00) H are decoded to detect any address within these ranges.

A control flip-flop is associated with each group (PAR or PDR of User, Supervisor, or Kernel mode). These flip-flops are cleared at T1 of each Bust cycle, when a new address is put on the lines. Time is allowed for decoding. Then, at T5 of the Bust cycle, the flip-flops are clocked. If an internal PAR or PDR is addressed, the output of the associated flip-flop is used to condition the CS (Chip Select) inputs to that specific APR set (drawings SAPA through SAPF).

### 3.16.2 SSR Decode and Control

**3.16.2.1 SSR REG** – The D input to the SSR REG flip-flop is qualified only by addresses 777572 (SR0), 777574 (SR1), or 777576 (SR2). When one of these registers is addressed during a Bust cycle, SSR REG is set at T5. If the bus transaction is a DATO or DATOB, TMCE C1 H is asserted. As a result, SSRL WRITE SR0 REG H is asserted to allow data to be written into SR0 under program control. SSR REG is cleared at T1 of the next Bust cycle, after the data has been written.

**3.16.2.2 INT SR3** – The SR3 address (772516) is decoded on SSRL. When SR3 is addressed, INT SR3 is set (drawing SAPN). SSRL INT SR3 (1) H allows data to be clocked into SR3. SSRL READ SR3 H is asserted if the transaction is DATI or DATIP to gate the contents of SR3 onto the processor internal data bus.

### 3.16.3 Internal Register Fast Decode

All of the internal register addresses decoded on drawing SSRL are ORed to provide SSRL INT REG FAST L. If any internal register is addressed, that signal is available at T5 of the Bust cycle. It is used to provide the correct APR address (Paragraph 3.3.1.2).

At the same time, the inputs to the internal register control flip-flops are ORed to provide SSRL INT REG ADRS. Thus, if any internal register address is decoded, KT11-C FAST is set at T5 of the Bust cycle. SSRL KT11-C FAST (1) L is sent to the KB11-A to indicate that a Fastbus device has acknowledged the address.

# CHAPTER 4

## INSTALLATION AND MAINTENANCE

### 4.1 INSTALLATION

The installation procedure for the KT11-C Memory Management Unit option is included as part of the complete PDP-11/45 system installation procedure described in the *PDP-11/45 System Maintenance Manual*. When the KT11-C is included as part of the initial PDP-11/45 system, the M8108 SSR module and the M8107 SAP module are installed prior to shipment. If the KT11-C option is added to an existing PDP-11/45 system, the installation procedure is straightforward. The M8116 SJB module is removed from slot 14 of the CPU backplane assembly and replaced with the M8107 SAP module. The M8108 SSR module is installed in slot 13 of the CPU backplane assembly. The KT11-C option is then ready to be checked out, using the diagnostic programs supplied with the option.

### 4.2 MAINTENANCE

The design, construction, and implementation of the M8107 SAP and M8108 SSR modules that constitute the KT11-C Memory Management Unit option is similar to those used in the KB11-A Central Processor and other options. Maintenance procedures for the entire system are described in the *PDP-11/45 System Maintenance Manual*, Chapter 4. Special maintenance procedures for the KT11-C option are included in the *PDP-11/45 Maintenance Manual*, Chapter 4.

#### 4.2.1 Diagnostic Programs

Chapter 4 of the *PDP-11/45 System Maintenance Manual* includes a list of the KT11-C diagnostic programs. These programs are part of a complete package of basic processor and option diagnostics. The sequence of running the diagnostics is set up to completely test the KB11-A Central Processor Unit before attempting to run KT11-C diagnostic programs, thus eliminating the KB11-A as a possible cause of a memory management failure.

The MAINDEC (maintenance descriptions) for each diagnostic program indicates how the program is to be loaded and run. The program listing indicates the functional logic that is being tested by each routine. The diagnostic programs are written along functional lines to test and exercise all the KT11-C logic.

#### 4.2.2 Troubleshooting Test Procedures

The use of the W131 maintenance card and the W900 Extender Modules is described in Chapter 4 of the *PDP-11/45 System Maintenance Manual*.

#### 4.2.3 Repair Procedures

Specific procedures to remove and replace integrated circuit chips are illustrated in Chapter 4 of the *PDP-11/45 System Maintenance Manual*.



# APPENDIX A

## GLOSSARY

| Term              | Definition  |
|-------------------|---|
| Abort             | A processor interrupt that can occur at any memory reference, not just between instructions. The KT11-C will cause an abort if an address attempts to access a non-resident address, to write into a read-only page, or violates the length of a page. When the abort occurs, the KT11-C logs the page number causing the abort, the virtual address of the instruction causing the abort, and any other information necessary to process the abort. A KT11-C abort takes a new PC from Kernel D virtual address 250 and a new PS from 252. The old PS and PC are pushed on the stack specified by the new PS bits (14:15). |
| Address Space     | The set of addresses used during processing in a specific processor mode (Kernel, Supervisor, User). The Virtual Address Space is that set of addresses authorized by the KT11-C for a particular mode. The Physical Address Space for the mode is the virtual address space as mapped into physical addresses. In general, the Kernel, Supervisor, and User modes will operate out of the same virtual address space but out of different physical address spaces.   |
| BEND              | Acronym for Bus END – meaning that the bus cycle (read “memory” cycle) in process is terminated. A BEND condition occurs when an anticipatory fetch turns out to be wrong or when some error condition is detected on the reference. When the BEND condition is detected in the KT11-C logic, no abort or memory management trap can occur on the reference.  |
| BUST              | Acronym for BUs Start (read “memory cycle” start). The name of the processor state that constitutes the first half of a memory cycle. The second half of the memory cycle is designated PAUSE.  |
| Internal Register | All Page Address Registers, Page Descriptor Registers, Status Registers 0, 1, 2, and 3 are considered to be “internal registers”.   |
| Mode              | The PDP-11/45 has three modes of operation: Kernel, Supervisor, and User. The KT11-C provides a separate set of PAR/PDR registers for use in each of these modes. The mode is specified by bits (15:14) in the processor status (PS) word: 00 = Kernel, 01 = Supervisor, 11 = User.   |

| Term                           | Definition  |
|--------------------------------|---|
| Operating System               | A collection of programs that provides facilities and service to a user by allocating resources (CPU, memory, I/O) among several users. An operating system is identical to a “control” program, a “monitor” program, or “supervisor” program. The PDP-11/45 is designed to run the operating system in the Kernel and Supervisor modes.  |
| PA                             | An abbreviation for “Physical Address”.   |
| Page                           | A collection of continuous memory addresses. The KT11-C divides the 32K word processor address space into eight 4K sections called pages. The lowest address in each page is a whole multiple of 4096. The length of the page is some whole multiple of 32 through 128. Thus, a page may vary in size from 32 to 4096 words, in 32 word increments, and begins on a 4096 word boundary. |
| PAR – Page Address Register    | A register containing the “base address” or “relocation constant” associated with a page. The KT11-C has 48 PARs, 16 associated with each of the three processor modes (User, Supervisor, and Kernel).  |
| Pause                          | The term used to describe the second half of a memory cycle. During the Pause cycle, KT11-C status registers are updated and the processor, if necessary, pauses to wait for completion of the current memory cycle.  |
| PDR – Page Descriptor Register | A register containing information associated with a page. This includes the length of the page, the expansion direction, and the access key. The KT11-C has 48 PDRs, 16 associated with each of the three processor modes (User, Supervisor, and Kernel).   |
| Physical Address               | The address generated by the KT11-C that is used to select a specific memory location. When the KT11-C is operating, the “physical address” is identical to the “relocated address”.  |
| ROM – Read Only Memory         | A hardware device that is able to store bit patterns that can be read by providing a specific address. In the KT11-C, four ROMs are used to control modifications to status registers, detect exceptions, and separate I space references from D space references.  |
| VA                             | An abbreviation for “Virtual Address”.  |
| Virtual Address                | The address generated by the PDP-11/45 processor. The term “virtual” is applied because the address will be relocated by the contents of the PAR. The memory location reached will be the relocated address. Hence, the processor “thinks” it is addressing one location but actually gets another. The first address is then really a dummy or “virtual” address.                      |

## APPENDIX B

# REFERENCE LITERATURE

The following list of references covers some of the more general aspects of memory management tasks of interest to systems programmers. It is part of the recommended bibliography of the National Academy of Engineering for its course outline on "Operating System Principles".

The following abbreviations are used in the bibliography.

|         |  |
|---------|--|
| ACM     | Association for Computing Machinery  |
| IEEE    | Institute for Electrical and Electronics Engineers   |
| IEEE TC | IEEE Transactions on Computers   |
| CACM    | Communications of the ACM  |
| JACM    | Journal of the ACM   |
| CS      | Computing Surveys (ACM)  |
| FJCC    | Fall Joint Computer Conference   |
| SJCC    | Spring Joint Computer Conference   |
| 2SOSP   | Second Symposium on Operating Systems Principles (proceedings available from ACM, 1133 Avenue of Americas, New York, N.Y. 10036) |

- Abate, J., and Dubner, H. Optimizing the Performance of a Drum-Like Storage. *IEEE Trans. C-18*, 11 (Nov. 1969), 992–997.
- Belady, L.A. A Study of Replacement Algorithms for Virtual Storage Computers. *IBM Sys. J.* 5, 2 (1966), 78–101.
- Bensoussan, A., Clingen, C.T., and Daley, R.C. The Multics Virtual Memory. *Proc. 2SOSP* (Oct. 1969).
- Denning, P.J. The Working Set Model for Program Behavior. *Comm. ACM* 11, 5 (May 1968), 323–333.
- Denning, P.J. Thrashing: Its Causes and Prevention. *AFIPS Conf. Proc.* 33 (1968 FJCC), 915–922.
- Denning, P.J. Virtual Memory. *CS* 2, 3 (Sept. 1970), 153–189.
- Dennis, J.B. Segmentation and the Design of Multiprogrammed Computer Systems. *JACM* 12, 4 (Oct. 1965), 589–602.
- Kilburn, T. et al. One-Level Storage System. *IRE Trans. EC-11*, 2 (Apr. 1962), 223–235.
- Knuth, D.E. *The Art of Computer Programming* (Vol. 1). Addison-Wesley (1968), Ch. 2.
- Mattson, R.L., Gecsei, J., Slutz, D.R., and Traiger, I.L. Evaluation Techniques for Storage Hierarchies. *IBM Sys. J.* 9, 2 (1970), 78–117.
- Randell, B., and Keuhner, C.J. Dynamic Storage Allocation Systems. *Comm. ACM* 11, 5 (May 1968), 197–305.
- Sayre, D. Is Automatic Folding of Programs Efficient Enough to Displace Manual? *CACM* 12, 12 (Dec. 1969), 656–660.
- Wilkes, M.V. Slave Memories and Dynamic Storage Allocation. *IEEE Trans. EC-14* (Apr. 1965), 270–271.
- Wilkes, M.V. *Time-Sharing Computer Systems*. Am. Elsevier (1968).



## INDEX

- A
- A (Attention) Bit  
for gathering statistics, 2.4.5  
logic, 3.3.2.4  
purpose, 2.1.3
- Abort  
control sequence, F3-4  
decode logic, 3.6.1  
flags, format, 2.3.1  
flags, logic, 3.11.1  
mechanism, 2.1.4  
processing, 2.4.8.1  
recovery, F2-15
- Access Control Field  
ACF, 2.1.2.1  
detailed functions, 2.2.2.1  
keys, T2-2
- ACF Keys  
definitions, T2-2  
statistics gathering aids, 2.1.3, 2.4.5
- Address  
assignments, 2.2  
display, 3.5.1, F3-3  
drivers, 3.8  
PAR/PDR assignments, T2-1  
path, 3.2.1  
physical, F2-3  
relocation, 2.1.1  
relocation sequence, F3-8  
selection switch, 2.4  
virtual, 1.3.2
- Active Page Registers, F2-5
- Attention  
A bit, 2.2.2.4  
ATTN flip-flop, 3.3.2.4
- Autodecrement/Autoincrement, 3.10.2.4, 3.12.2
- B
- Base Address, 2.1.1
- Block Number, 2.2.2.5
- Bus Pause Timing, F3-8
- C
- Communication Between Programs, 2.4.4
- Console  
operation with KT11-C, 2.4.1.1  
mode control, 3.5.2
- D
- Destination Mode  
control logic, 3.11.4  
purpose of bit, 2.3.1.7
- Dynamic Memory Allocation, 2.2.2.5
- D Space  
control logic, 3.10.6  
PDR, 2.1.2.2  
use of, 2.4.6  
enable D space, 2.3.4
- E
- Execute-Only Protection, 1.3.1, 2.1.2.2
- Expansion Direction, 2.2.2.2  
downward, F2-9  
upward, F2-8  
memory, 1.3.3
- F
- Fast Decode, Internal Registers, 3.16.3
- Fastbus, 3.1

## INDEX (Cont)

Fault Detection Logic, 3.5

Fault Recovery, F2-15

G

General Registers

address logic, 3.12.1

status, 2.3.2

I

I/D space

bit of SR0, 2.3.1.9

control by SR3, 2.3.4

control logic, 3.10.6

KT11-C capability, 1.3.5

limitations, 2.4.6

Instruction Complete, 2.3.18

bit use, 2.4.10

Interface, hardware, F3-1

Internal Registers

access timing, F3-9

control logic, 3.16

fast decode, 3.16.3

inhibit, 3.6.2

SR0, SR1, SR2, and SR3, 2.3

Internal Data Bus, 3.14

K

Kernel Space

address assignments, T2-1

control logic, 3.10.3

general, 1.3.7

SR0 mode field, 3.11.6

M

Memory Expansion, 1.3.3

Memory Protection, 2.1.2, 2.4.3

Memory Management

enable, 2.3.1.6

ROM, 3.10

statistics, 2.1.3

status registers, 2.3

trap logic, 3.11.2

N

Non-Reentrant Programs, 2.1.2.2

Non-Resident

page fault, 3.6.1

protection, 2.1.2.1

P

PAR/PDR, 2-5

addresses, T2-1

description, 3.3

multiplexers, 3.7

selection, 3.3.3.1

Page Address Field (PAF), 2.1.1

format, F2-6

logic, 3.3.1

Page Address Register (PAR), 2.1.1

address assignments, T2-1

contents, 2.2

format, F2-6

logic, 3.3.1

Page Descriptor Register (PDR)

address assignments, T2-1

contents, 2.2

format, F2-7

logic, 3.3.2

## INDEX (Cont)

### Page

- expansion, 2.2.2.2
- fault recovery, F2-15
- length, 1.3.1, T1-1
- variable length, 1.3.4

### Page Number, 3.11.8

### Physical Address

- construction, F2-3
- determination, 2.4.2
- display, T2-3
- overlapping, 2.4.4.1
- no. virtual address, 1.3.2

### Power Requirements, T1-1

### Processor Status Word, 2.1.2.3

- modification, 2.4.8

### Protection

- kernel mode, 2.4.7.1
- memory, 1.3.1

### PS Restore, 3.10.2.1

### PSW Bits, Current Mode, 2.1.2.4

## R

### Read-Only

- fault logic, 3.6.1.2
- protection, 2.1.2.1

### Read-Only Memory (ROM), 3.10.1

### Recovery

- from abort, 2.4.10
- from I/O lockout, 2.4.7.2
- routine, flow chart, F2-15

### Reentrant Programs, 2.1.2.2

### Relocation

- address relocation, 2.1.1
- block diagrams, F2-1, F2-2
- definition, 1.3.2
- logic, 3.4
- timing, F3-8

### ROM

- organization, 3.10.1
- output decode, T3-3

## S

### SAP Module M8107

- functions, F3-2
- installation, 4.1
- location, T1-1

### SSR Module M8108

- functions, F3-2
- installation, 4.1
- location, T1-1

### Stack

- communication, 2.4.4.2
- downward expandable page, 2.2.2.5
- no program, 1.3.8

### Statistics

- gathering routine, 2.4.5
- memory management, 2.1.3

### Status Registers

#### format

- SR0, 2.3.1
- SR1, 2.3.2
- SR2, 2.3.3
- SR3, 2.3.4

#### logic

- SR0, 3.11
- SR1, 3.12
- SR2, 3.13
- SR3, 3.9

### Supervisor Space

- address assignments, T2-1
- control logic, 3.10.4
- general, 1.3.7
- SR0 mode field, 3.11.6

### Swapping, 2.1.3

## INDEX (Cont)

- T
- T-Bit, 2.3.3  
    SR2 logic, 3.13
- Timing  
    diagram, F3-7  
    event times, T3-5
- Trap  
    control logic, 3.11.2  
    control sequence, F3-5  
    decode logic, 3.6.3  
    flag format, 2.3.1.4  
    memory management, 2.3.1.4  
    vector addresses, 2.4.11
- Trap/Abort  
    mechanism, 2.14  
    recovery, F2-15
- U
- Unibus  
    address drivers, 3-8  
    interface, F3-1
- User Space
- address assignments, T2-1  
    control logic, 3.10.5  
    general, 1.3.7  
    SR0 mode field, 3.11.7
- V
- Virtual Address  
    display, T2-3  
    inverters, 3.4.1  
    page numbers, 2.2  
    program counter, 2.3.3  
    vs physical addresses, 1.3.2
- W
- W (Written Into) Bit  
    logic, 3.3.2.4  
    purpose, 2.1.3  
    written into, 2.2.2.2

**NOTE:** T = Tables and F = Figures.

**READER'S COMMENTS**

Your comments and suggestions will help us in our continuous effort to improve the quality and usefulness of our publications.

What is your general reaction to this manual? In your judgment is it complete, accurate, well organized, well written, etc.? Is it easy to use? \_\_\_\_\_

\_\_\_\_\_  
\_\_\_\_\_  
\_\_\_\_\_

What features are most useful? \_\_\_\_\_

\_\_\_\_\_  
\_\_\_\_\_  
\_\_\_\_\_

What faults do you find with the manual? \_\_\_\_\_

\_\_\_\_\_  
\_\_\_\_\_  
\_\_\_\_\_

Does this manual satisfy the need you think it was intended to satisfy? \_\_\_\_\_

Does it satisfy *your* needs? \_\_\_\_\_ Why? \_\_\_\_\_

\_\_\_\_\_  
\_\_\_\_\_  
\_\_\_\_\_

Would you please indicate any factual errors you have found. \_\_\_\_\_

\_\_\_\_\_  
\_\_\_\_\_  
\_\_\_\_\_

Please describe your position. \_\_\_\_\_

Name \_\_\_\_\_ Organization \_\_\_\_\_

Street \_\_\_\_\_ Department \_\_\_\_\_

City \_\_\_\_\_ State \_\_\_\_\_ Zip or Country \_\_\_\_\_

