

**PDP-11/45  
system  
engineering drawings**

digital equipment corporation • maynard, massachusetts





# DRAWING DIRECTORY

THIS DRAWING AND SPECIFICATIONS, HEREIN, ARE THE PROPERTY OF DIGITAL EQUIPMENT CORPORATION AND SHALL NOT BE REPRODUCED OR COPIED OR USED IN WHOLE OR IN PART AS THE BASIS FOR THE MANUFACTURE OR SALE OF ITEMS WITHOUT WRITTEN PERMISSION. COPYRIGHT © 1976, DIGITAL EQUIPMENT CORPORATION

## CUSTOMER PRINT SET INDEX 11/45-1

- |                                    |                  |
|------------------------------------|------------------|
| DRAWING DIRECTORY (SHT 1 & 2 ONLY) | B-DD-11/45-0     |
| CONSOLE PHYSICAL LAYOUT            | E-IA-5409684-0-0 |
| CIRCUIT SCHEMATIC                  | D-CS-5409684-0-1 |
| DRAWING DIRECTORY (SHT 1 & 2 ONLY) | B-DD-KB11-A-0    |
| DRAWING DIRECTORY                  | B-DD-DL11-1      |
| DRAWING DIRECTORY                  | B-DD-KW11-L      |
| DRAWING DIRECTORY                  | B-DD-BM873-0     |
| DRAWING DIRECTORY (SHT 1 ONLY)     | B-DD-KT11-C-0    |
| ACCESSORY LIST                     | A-AL-KT11-C-0    |
| POWER SYSTEM CONFIGURATION         | D-IC-11/45-0-1   |
| 11/45 BACK PANEL PC BOARD          | D-IC-11/45-0-2   |
| WIRE LIST                          | K-WL-7009540-0-2 |
| DRAWING DIRECTORY (SHT 1 ONLY)     | B-DD-861-0       |
| DRAWING DIRECTORY (SHT 1 ONLY)     | B-DD-H742-0-0    |
| DRAWING DIRECTORY                  | B-DD-H742-0      |
| DRAWING DIRECTORY (SHT 1 ONLY)     | B-DD-H744-0      |
| DRAWING DIRECTORY (SHT 1 ONLY)     | B-DD-H745-0      |
| DRAWING DIRECTORY (SHT 1 ONLY)     | B-DD-H746-0      |
| CIRCUIT SCHEMATIC                  | E-CS-H754-0-1    |
| G772-OPTION HARNESS                | E-IA-7009562-0-0 |
| ACCESSORY LIST                     | A-AL-11/45-0-3   |
| ARRANGEMENT DRAWING                | D-AR-11/45-0-4   |
| ARRANGEMENT PARTS LIST             | C-PL-11/45-0-4   |
| DRAWING DIRECTORY (SHT 1 ONLY)     | B-DD-M9301-YB    |
| TABLE OF CONTENTS                  | B-TC-DL11-W      |

## CUSTOMER PRINT SET INDEX 11/45-2

- |                                  |                  |
|----------------------------------|------------------|
| DRAWING DIRECTORY (SHT 1&2 ONLY) | B-DD-11/45-0     |
| CONSOLE PHYSICAL LAYOUT          | E-IA-5409684-0-0 |
| CIRCUIT SCHEMATIC                | D-CS-5409684-0-1 |
| DRAWING DIRECTORY (SHT 1&2 ONLY) | B-DD-KB11-D-0    |
| DRAWING DIRECTORY                | B-DD-DL11-1      |
| DRAWING DIRECTORY                | B-DD-KW11-L      |
| DRAWING DIRECTORY                | B-DD-BM873-0     |
| DRAWING DIRECTORY (SHT 1 ONLY)   | B-DD-KT11-C-0    |
| ACCESSORY LIST                   | A-AL-KT11-C-0    |
| POWER SYSTEM CONFIGURATION       | D-IC-11/45-0-1   |
| 11/45 BACK PANEL PC BOARD        | D-IC-11/45-0-2   |
| WIRE LIST                        | K-WL-7009540-0-2 |
| DRAWING DIRECTORY (SHT 1 ONLY)   | B-DD-861-0       |
| DRAWING DIRECTORY (SHT 1 ONLY)   | B-DD-H742-0-0    |
| DRAWING DIRECTORY                | B-DD-H742-0      |
| DRAWING DIRECTORY (SHT 1 ONLY)   | B-DD-H744-0      |
| DRAWING DIRECTORY (SHT 1 ONLY)   | B-DD-H745-0      |
| DRAWING DIRECTORY (SHT 1 ONLY)   | B-DD-H746-0      |
| CIRCUIT SCHEMATIC                | E-CS-H754-0-1    |
| G772-OPTION HARNESS              | E-IA-7009562-0-0 |
| ACCESSORY LIST                   | A-AL-11/45-0-3   |
| ARRANGEMENT DRAWING              | D-AR-11/45-0-4   |
| ARRANGEMENT PARTS LIST           | C-PL-11/45-0-4   |
| DRAWING DIRECTORY (SHT 1 ONLY)   | B-DD-M9301-YB    |
| TABLE OF CONTENT                 | B-TC-DL11-W      |

## THIS IS PRINT SET

VAR	TITLE	PRINT SET		
		11/45-1	11/45-2	
11/45 CA	BASIC ASSY (PDP 11/45 115V	X		
11/45-CB	BASIC ASSY (PDP 11/45) 230V	X		
11/45-CC	BASIC ASSY & LA30 115V	X		
11/45-CD	BASIC ASSY & LA30 230V	X		
11/45-CE	BASIC ASSY & VT05B 115V	X		
11/45-CF	BASIC ASSY & VT05B 230V	X		
11/45-CH	BASIC ASSY & LA30 115V	X		
11/45-CJ	BASIC ASSY & LA30 230V	X		
11/45-CK	BASIC ASSY & VT05B 115V	X		
11/45-CL	BASIC ASSY & VT05B 230V	X		
11/45 FA	BASIC ASSY 115V	X		
11/45-FB	BASIC ASSY 230V	X		
11/45-GA	BASIC ASSY & LA30 115V	X		
11/45-GB	BASIC ASSY & LA30 230V	X		
11/45-GE	BASIC ASSY & LA30 115V	X		
11/45-GF	BASIC ASSY & LA30 230V	X		
11/45-AA	BASIC ASSY (PDP 11/45) 115V		X	
11/45-AB	BASIC ASSY (PDP 11/45) 230V		X	

REVISIONS	REV	CHG. NO.	11/45-00065 AH	REVISION	11/45-00066 AJ		USED ON OPTION/MODEL.	DRN.	DATE	TITLE BASIC ASSY (PDP 11/45)			
	DATE	4-76	REVISED & REDRAWN	6-76			PDP-11	R. COOK	4/72				
								CHK'D.	R. COOK		4/72		
								PROJ ENG.	B. DELAGI		4/72		
							PROD.	A. HIRSCH	5/72	SIZE	CODE	NUMBER	REV
							FIELD SERV.	A. ZINS	5/72	B	DD	11/45-0	AJ
							SHEET	OF	4	DIST			

EN-01062-1A-16-R972-1225

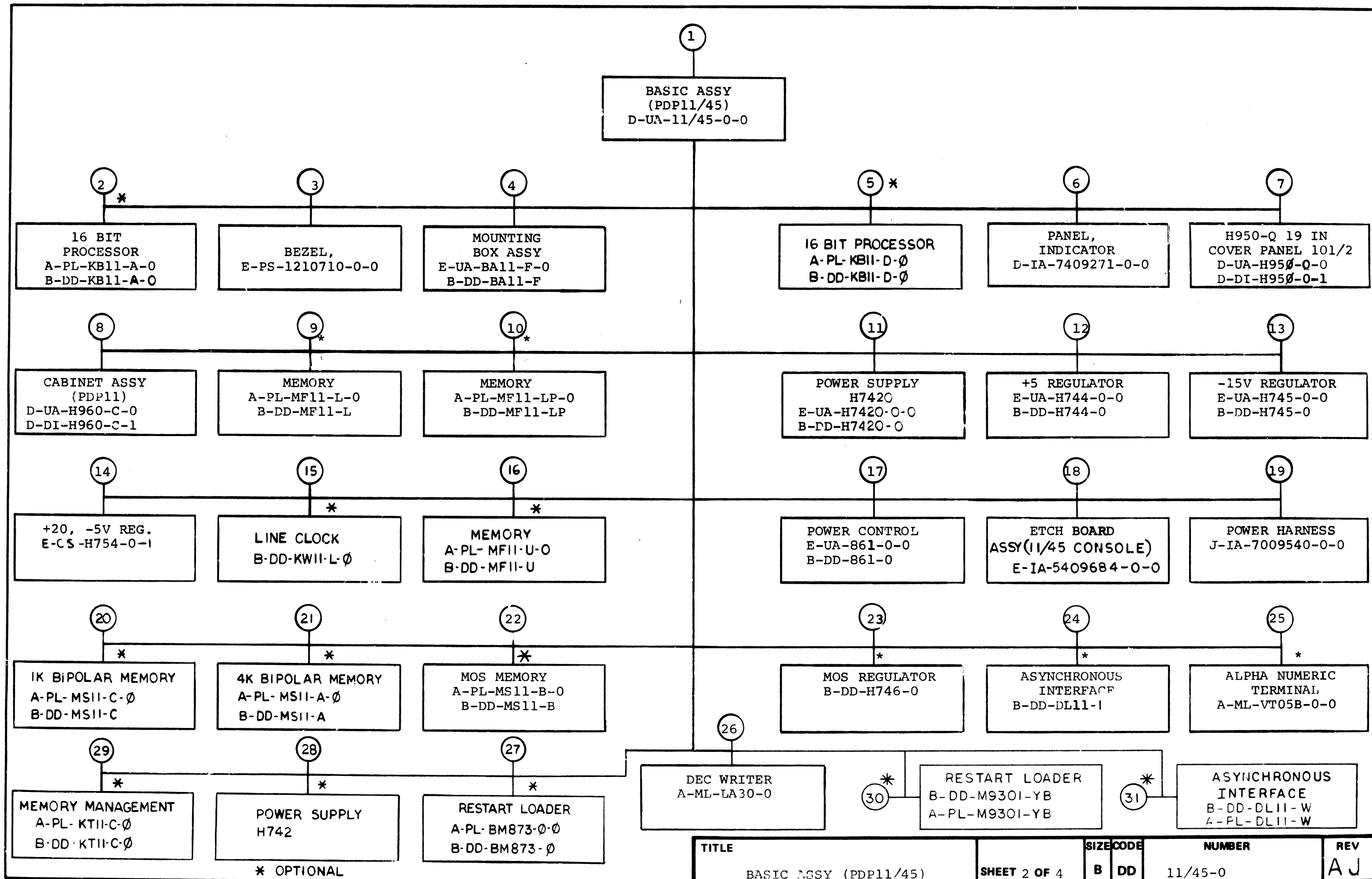

TITLE	SIZE	CODE	NUMBER	REV
BASIC ASSY (PDP11/45)	B	DD	11/45-0	AJ

KNOB LOCATIONS	
ITEM NO.	REFERENCE
8	S1-S3, S7-S9, S13-S15, S20, S22, S24, S26, S28
40	S4-S6, S10-S12, S16-S18, S21, S23, S25, S27
#1	S19

**NOTES CONT.**  
 3. IN ORDER TO GET THE PROPER ALIGNMENT BETWEEN ROTARY SWITCH #17 AND POWER LOCK #37, MOUNT ITEM #17 ON P.C. BOARD AND TURN SHAFT C'CLOCKWISE (LEFT) TO STOP. MOUNT ITEM #37 TO SUPPORT BRACKET ITEM #5 WITH 'D' HOLE IN POSITION INDICATED. ROTATE KEY POSITION INDICATED AS 'B' OF ITEM #37 TO LINE UP WITH KEY POSITION INDICATED AS 'A' OF ITEM #37.

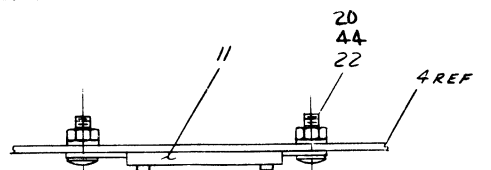

**NOTE 5**  
 1. AFTER ASSEMBLING ITEM #7 TO ITEM #8, THE TABS OF ITEM #7 ARE TO BE TWISTED AS SHOWN IN VIEW A-A  
 2. ON S1-S19, S26, S28, THE SWITCH ARM IS TO FLIP UP. THE SWITCH ARM TO FLIP DOWN ON 20-25:27.

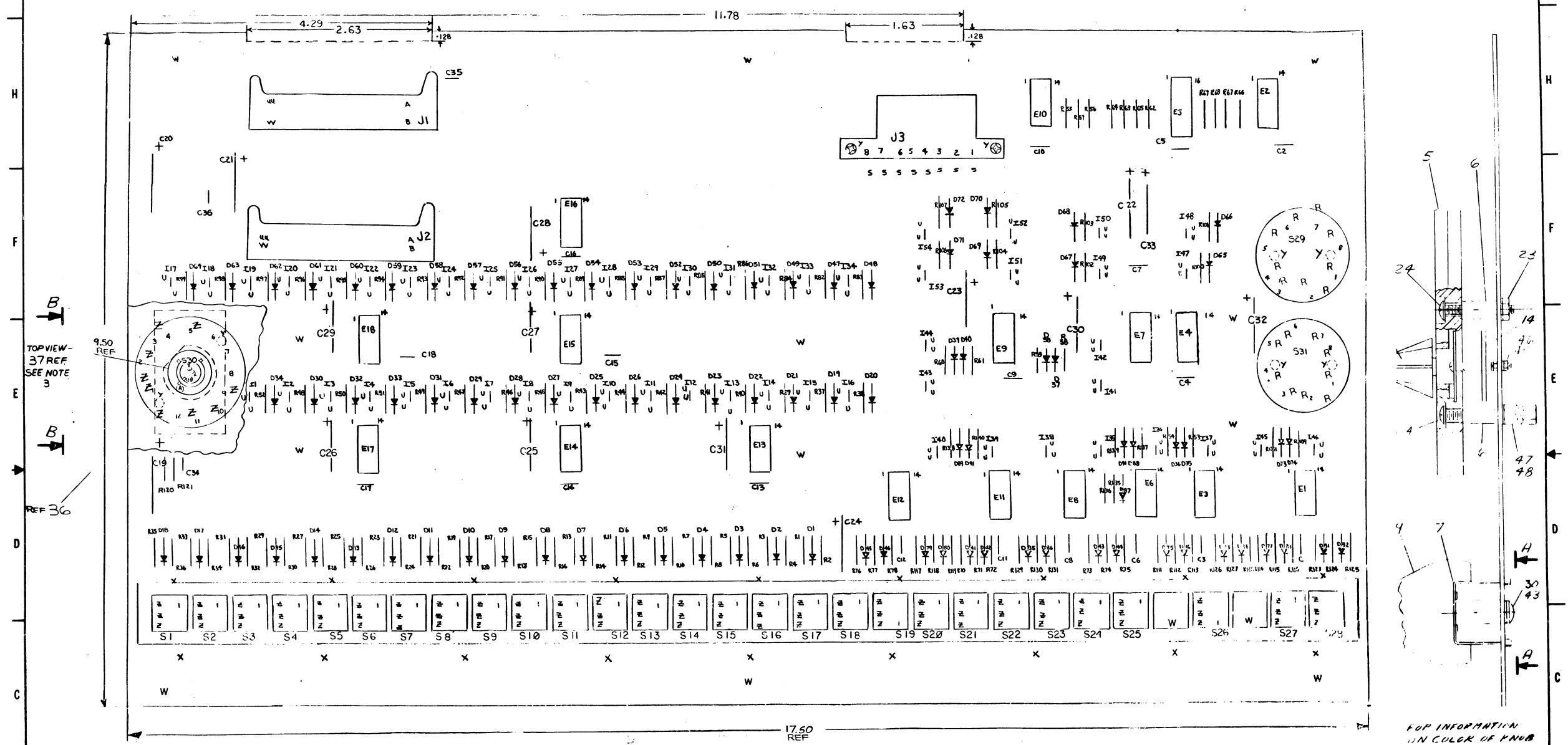

TOP VIEW - 37 REF SEE NOTE 3

REF 36

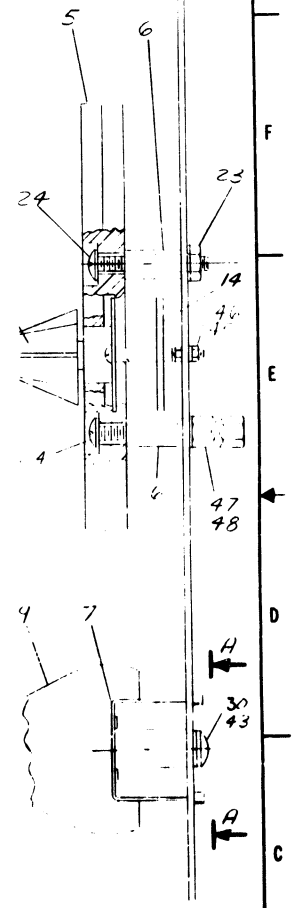

FOR INFORMATION IN COLOR OF KNOB SEE TABLE

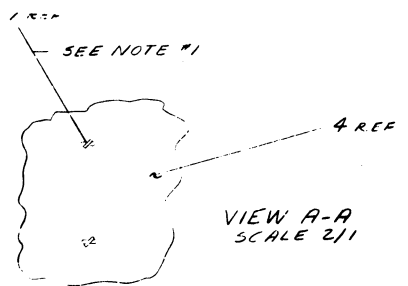
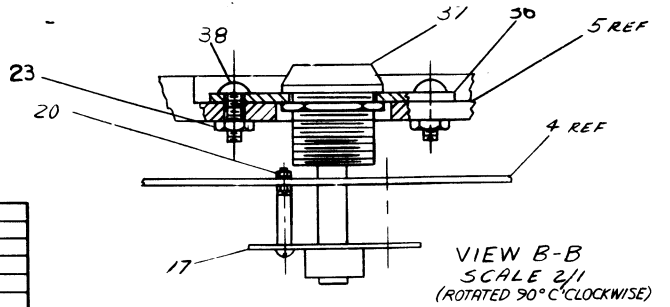

SEE SHEET 2 FOR PARTS LIST

IC TYPE	GRID	QTY	ITEM NO.	ANG	FROM PT	TO PT
K. PIN LOCATIONS						
JUMPER LIST						

QTY	REF	DESCRIPTION	PART NO.
PARTS LIST			
ETCH BOARD REV E			
EQUIPMENT CORPORATION			
ETCH BOARD ASSY (11/45 CONSOLE)			
SEMICONDUCTOR CONVERSION CHART			

The drawing and specifications herein, for the use of any person, are the property of the U.S. Government and are not to be distributed, copied, or used in any manner without the express written permission of the U.S. Government.

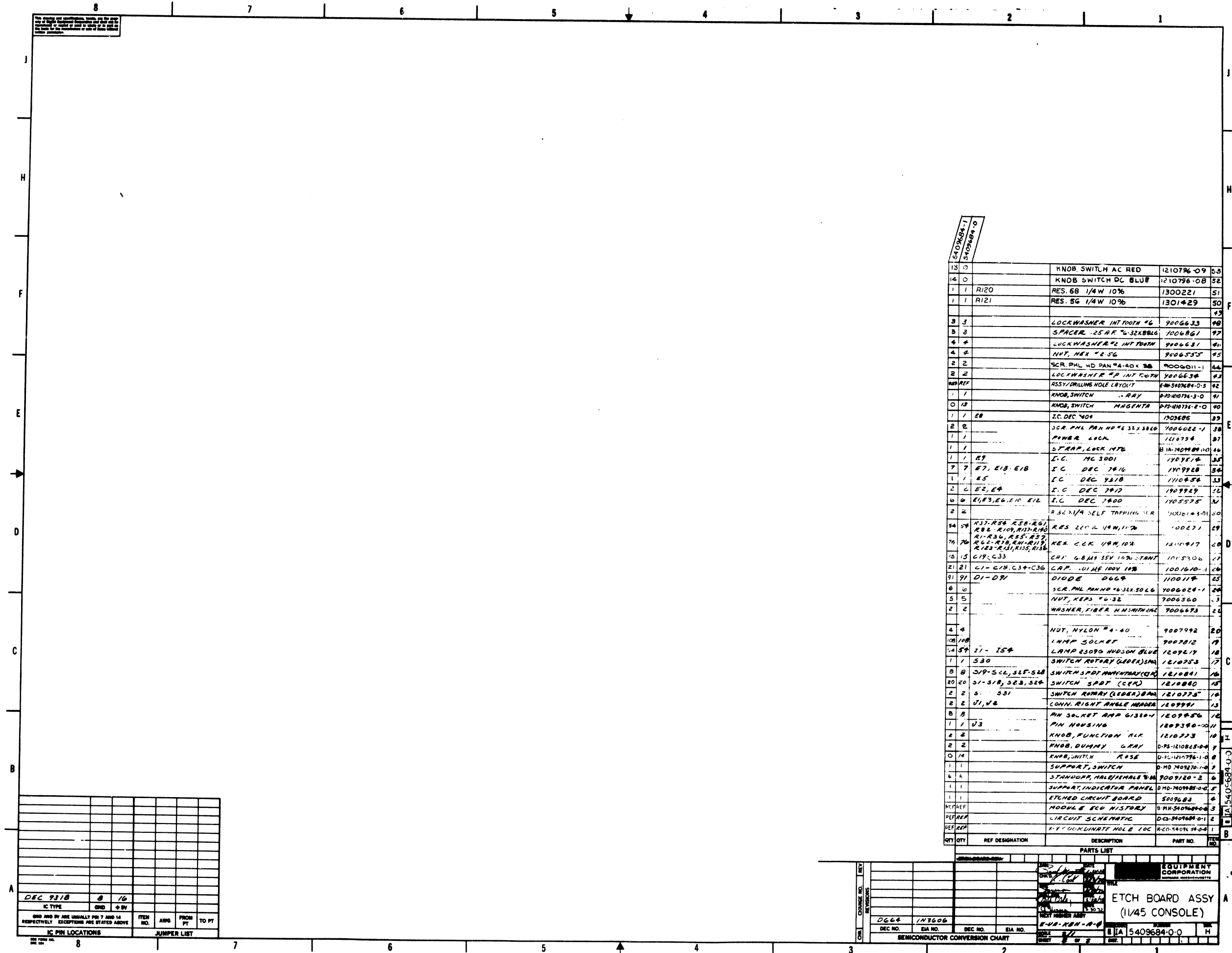

QTY	REF	DESIGNATION	DESCRIPTION	PART NO.	ITC NO.
15	0		KNOB, SWITCH AC RED	1210796-09	53
14	0		KNOB SWITCH DC BLUE	1210796-08	52
1	1	R120	RES. 68 1/4W 10%	1300221	51
1	1	R121	RES. 56 1/4W 10%	1301429	50
3	3		LOCKWASHER INT TOOTH #6	9006633	49
3	3		SPACER .25 X .625 X .3125	9006631	47
4	4		LOCKWASHER #2 INT TOOTH	9006631	46
4	4		NUT, NEX #2-56	9006555	45
2	2		SCR. PHL HD PAN #4-40 X .38	9006011-1	44
2	2		LOCKWASHER #2 INT TOOTH	9006633	43
REF	REF		ASSY/DRILLING HOLE LAYOUT	844-540784-0-5	42
1	1		KNOB, SWITCH . . . RAY	844-540784-3-0	41
0	13		KNOB, SWITCH MAGENTA	844-540784-2-0	40
1	1	E8	I.C. DEC 7404	1702686	39
2	2		SCR. PHL PAN #4-40 X .38	9006022-1	38
1	1		POWER LOCK	1210754	37
1	1		STRAP, LOCK INT	844-540784-0-10	36
1	1	E7	I.C. MC 3001	1702514	35
7	7	E7, E13, E18	I.C. DEC 7416	1702928	34
1	1	E5	I.C. DEC 7418	1710454	33
2	2	E2, E4	I.C. DEC 7417	1702929	32
10	10	E13, E6, E10, E12	I.C. DEC 7400	1705575	31
2	2		R .32 X 1/4 SELF TAPPING SCR	9002143-01	30
54	54	R37-R54, R58-R61, R62, R109, R117-R119, R1-R36, R55-R57	RES 200 OHM 1/4W, 10%	100271	29
76	76	R62-R78, R81-R115, R123-R131, R135, R136	RES 1K OHM, 10%	1210717	28
15	15	C19-C33	CAP. 6.8UF 35V 10% TANT	1005306	27
21	21	C1-C18, C34-C36	CAP. .01UF 100V 10%	1001610-1	26
91	91	D1-D7	DIODE D669	1100114	25
6	6		SCR. PHL PAN #4-40 X .38	9006024-1	24
5	5		NUT, KEPS #6-32	9006360	23
2	2		WASHER, FIBER NYLON 6/8	9006673	22
4	4		NUT, NYLON #4-40	9007992	20
100	100		LAMP SOCKET	9007812	19
54	54	I1-I54	LAMP 230V HUDSON BLUE	1209214	18
1	1	S30	SWITCH ROTARY (LEDER) 30A	1210753	17
8	8	S19-S22, S25-S28	SWITCH SPDT MOMENTARY (CR)	1210841	16
20	20	S1-S18, S23, S24	SWITCH SPDT (CR)	1210840	15
2	2	S1, S31	SWITCH ROTARY (LEDER) 30A	1210775	14
2	2	J1, J2	CONN. RIGHT ANGLE HEADER	1209991	13
8	8		PIN SOCKET AMP G1384	1209956	12
1	1	J3	PIN HOUSING	1209390-02	11
2	2		KNOB, FUNCTION BLK	1210773	10
2	2		KNOB, DUMMY GRAY	D-PS-1210825-04	9
0	14		KNOB, SWITCH ROSE	D-PS-1210796-11-0	8
1	1		SUPPORT, SWITCH	D-MD-709270-1-0	7
6	6		STANDARD, MALE/FEMALE 8MM	9009120-2	6
1	1		SUPPORT, INDICATOR PANEL	D-MD-709980-0-5	5
1	1		ETCHED CIRCUIT BOARD	5209683	4
REF	REF		MODULE ECO HISTORY	844-540784-0-3	3
REF	REF		CIRCUIT SCHEMATIC	DCS-5407684-0-1	2
REF	REF		X-Y COORDINATE HOLE LOC	R-CO-74074-0-1	1

IC TYPE	QTY	ANG	FROM PT	TO PT
DEC 7418	1			
DEC 7417	2			
DEC 7416	7			
MC 3001	1			
DEC 7404	1			
DIODE D669	6			
SCR. PHL PAN #4-40 X .38	2			
NUT, KEPS #6-32	5			
WASHER, FIBER NYLON 6/8	2			
NUT, NYLON #4-40	4			
LAMP SOCKET	100			
LAMP 230V HUDSON BLUE	54			
SWITCH ROTARY (LEDER) 30A	1			
SWITCH SPDT MOMENTARY (CR)	8			
SWITCH SPDT (CR)	20			
SWITCH ROTARY (LEDER) 30A	2			
CONN. RIGHT ANGLE HEADER	2			
PIN SOCKET AMP G1384	8			
PIN HOUSING	1			
KNOB, FUNCTION BLK	2			
KNOB, DUMMY GRAY	2			
KNOB, SWITCH ROSE	0			
SUPPORT, SWITCH	1			
STANDARD, MALE/FEMALE 8MM	6			
SUPPORT, INDICATOR PANEL	1			
ETCHED CIRCUIT BOARD	1			
MODULE ECO HISTORY	REF			
CIRCUIT SCHEMATIC	REF			
X-Y COORDINATE HOLE LOC	REF			

REVISIONS

NO.	DATE	DESCRIPTION
1		
2		
3		
4		
5		
6		
7		
8		
9		
10		

CHG. NO. 0664 INTG06

SEMICONDUCTOR CONVERSION CHART

EQUIPMENT CORPORATION  
ETCH BOARD ASSY  
(1145 CONSOLE)

5409684-0-0

This drawing and specifications, herein, are the property of Digital Equipment Corporation and shall not be reproduced or copied in whole or in part as the basis for the manufacture or sale of items without written permission.

"SWITCH REGISTER" SWITCHES SHOWN IN LOGICAL "0" STATE (DOWN)

- NOTES:
- CONTROL LOGIC AND DISPLAY GROUNDS MUST BE KEPT SEPARATE
  - ALL RESISTORS ARE 2.2K UNLESS MARKED OTHERWISE
  - ALL UNMARKED DIODES ARE D664

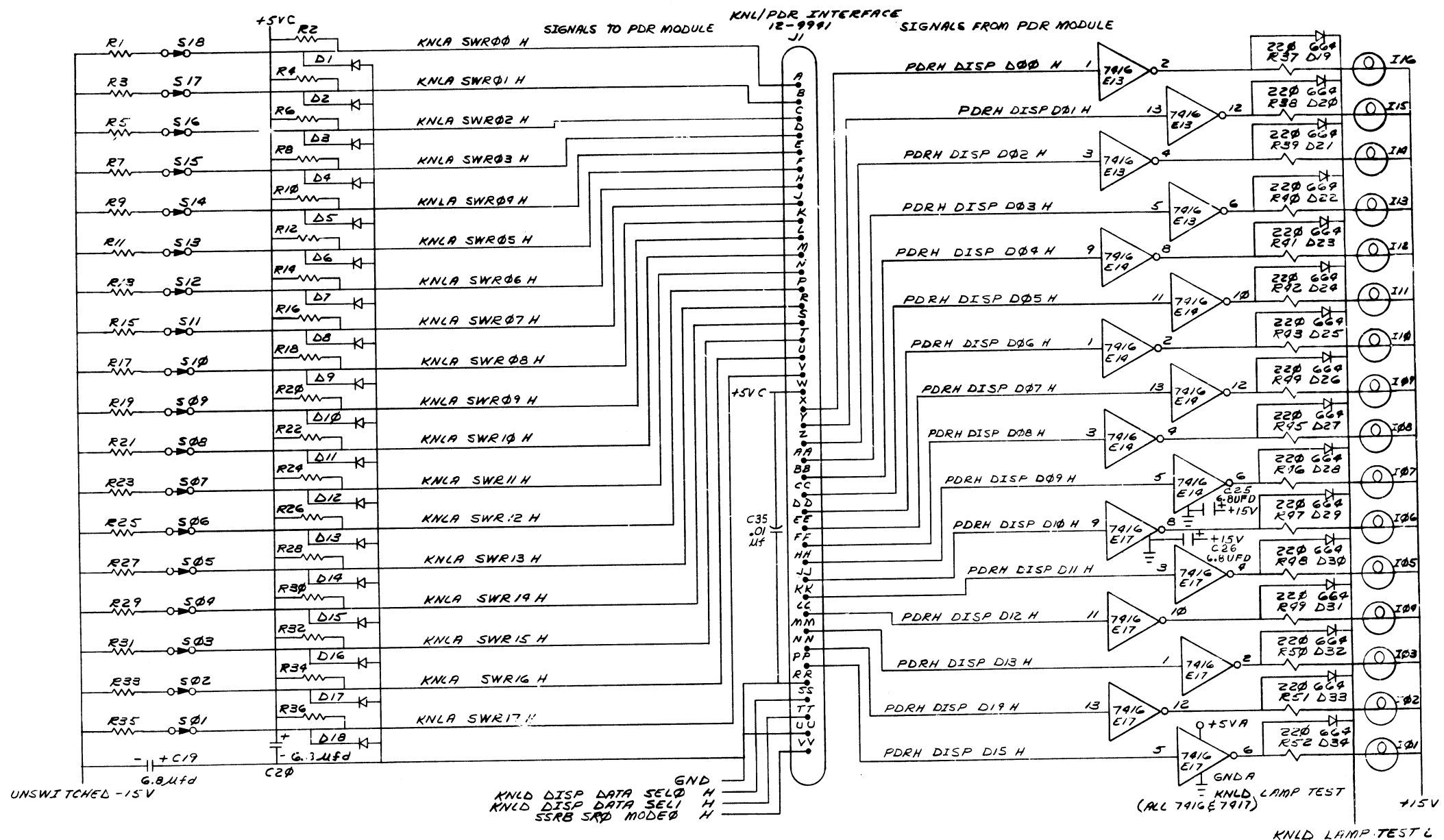

REV	DATE	BY	CHK	DESCRIPTION
1	11-14-72	J. SWANSON		INITIAL DESIGN
2	11-14-72	J. SWANSON		REVISION
3	11-14-72	J. SWANSON		REVISION
4	11-14-72	J. SWANSON		REVISION
5	11-14-72	J. SWANSON		REVISION
6	11-14-72	J. SWANSON		REVISION
7	11-14-72	J. SWANSON		REVISION
8	11-14-72	J. SWANSON		REVISION

FIRST USED ON OPTION/MODEL	QTY.	DESCRIPTION	PART NO.	ITEM NO.
11/45		PARTS LIST		
UNLESS OTHERWISE SPECIFIED DIMENSION IN INCHES TOLERANCES		DATE	digital EQUIPMENT CORPORATION	
DECIMALS	ANGLE	DATE	MAYNARD MASSACHUSETTS	
XXX - .005	± 0° 30'	DATE	TITLE	
XX - .02		DATE	11/45 CONSOLE BOARD	
X - .1		DATE	KNLA	
REMOVE BLARS AND BREA. SHARP CORNERS SURFACE QUALITY	PROD.	DATE	REV.	
MATERIAL	NEXT HIGHER ASSY.		NUMBER	
FINISH	SCALE		DCC 5409684-0-1	H
	SHEET 1 OF 4			

This drawing and specifications, herein, are the property of Hughes Aircraft Corporation and shall not be reproduced or used in whole or in part as the basis for the manufacture of any of items without written permission.

**NOTES:**  
 CONTROL SWITCHES ARE SHOWN IN THEIR "NORMAL" OR "MAN OPERATING" POSITION. SWITCHES WITH ARROWS POINTING UP ARE PUSHED DOWN TO OPERATE THOSE WITH ARROWS DOWN ARE LIFTED TO OPERATE. CONTROL SWITCHES 525 THRU 528, 519 THRU 523 ARE MOMENTARY SPDT. ALL TAPS ON SWITCHES 1 THRU 8 ARE TO BE CONNECTED TO +5VB AND FUNCTION SW GND RETURN.

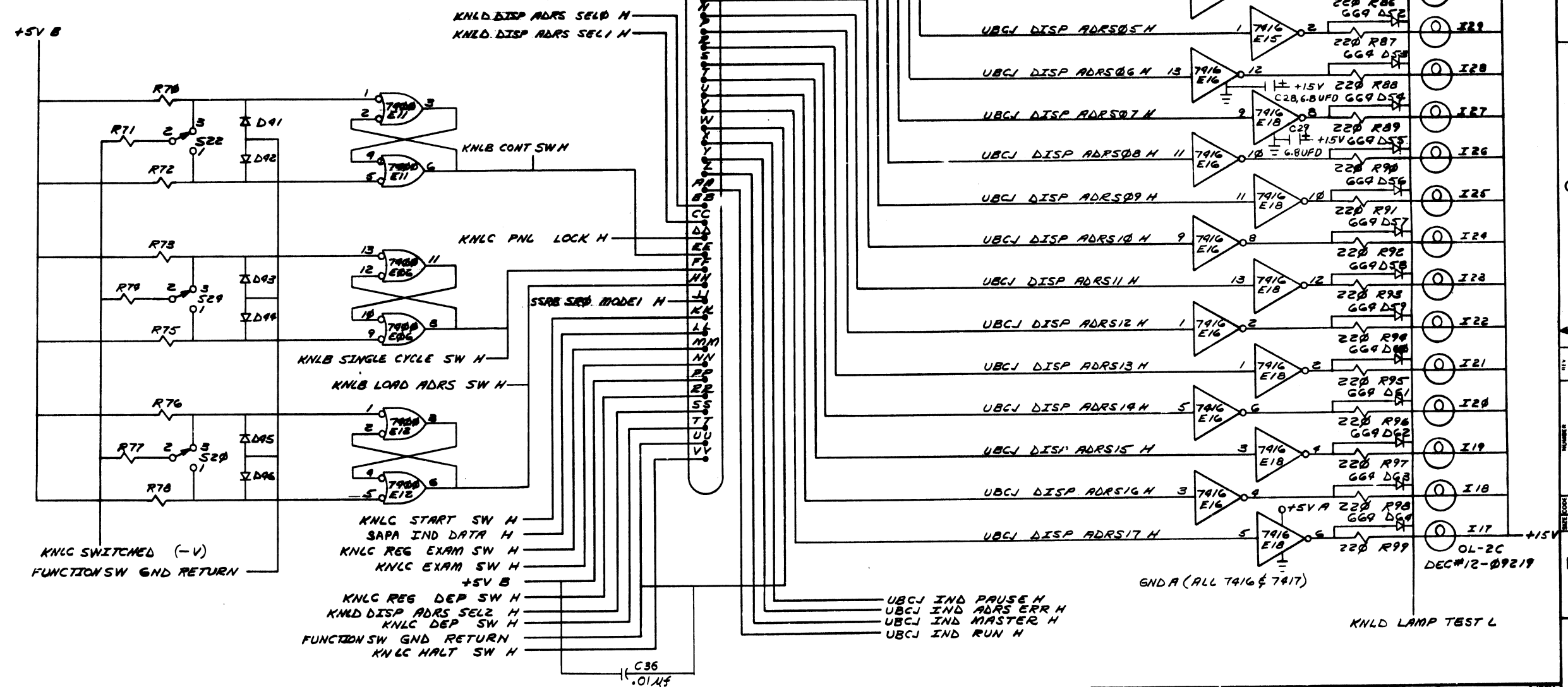

FIRST USED ON OPTION/MODEL	QTY	DESCRIPTION	PART NO.	ITEM NO.
11145				
PARTS LIST				
UNLESS OTHERWISE SPECIFIED				
DIMENSION IN INCHES		DRN	DATE	
TOLERANCES		CHK	DATE	
DECIMALS	ANGLES	ENG	DATE	
.XXX ± .006	± 0° 30'	PROJ. ENG.	DATE	
.XX ± .02		PROD.	DATE	
X ± .1				
REMOVE BURRS AND BREAK SHARP CORNERS SURFACE QUALITY				
MATERIAL		NEXT HIGHER ASSY.		
		B-00-11145-0	SIZE CODE	NUMBER
FINISH		SCALE NONE	DCS 5409684-0-1	REV. M
		SHEET 2 OF 4	DIST.	

10-522 12-9991  
 REV. CHANGE NO.  
 DDC FORM NO. DDD 109-8

DCS 5409684-0-1

Indications herein are the property of Digital Equipment Corporation and shall not be used in whole or in part as a basis for reproduction or sale of items without the written consent of Digital Equipment Corporation.

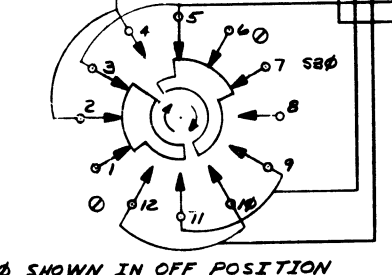
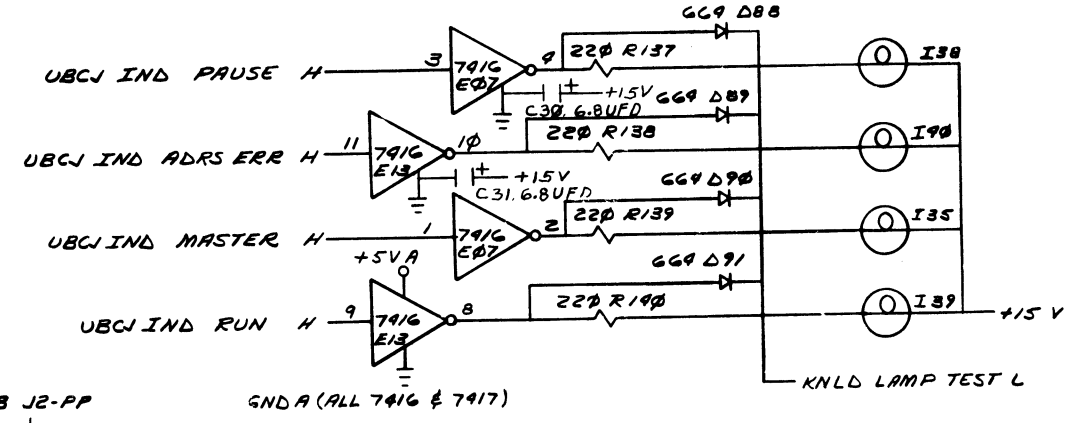
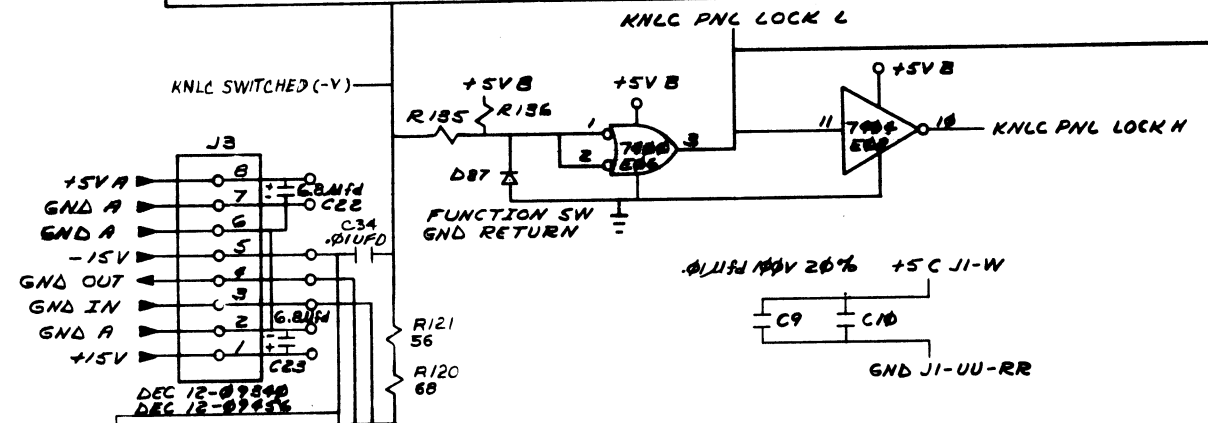
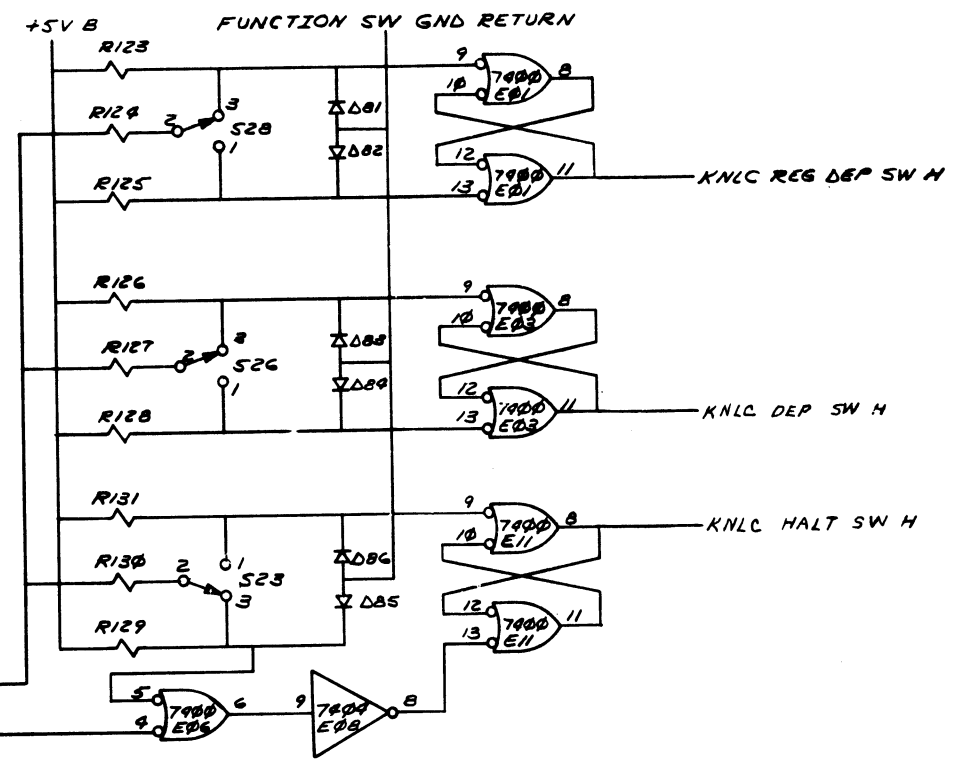
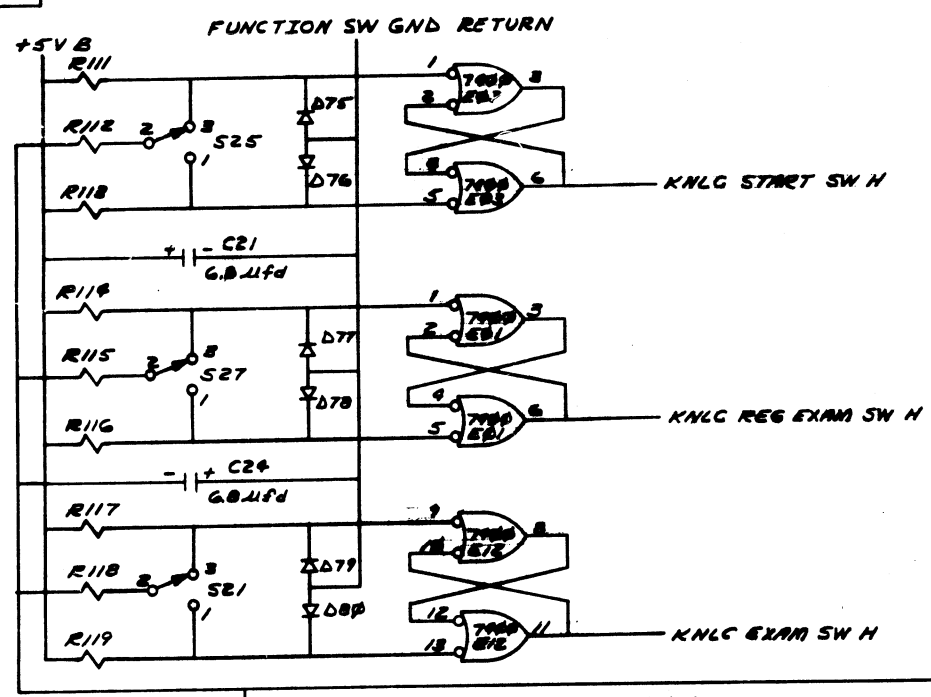

POSITION	POLE	FUNCTION
POS 1	2, 3	OFF
POS 2	9, 5, 8, 10	ON
POS 3	11, 12	ON PAN/LOCK

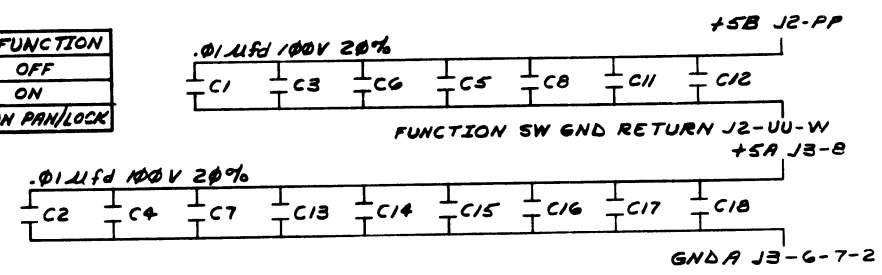

FIRST USED ON OPTION/MODEL	QTY.	DESCRIPTION	PART NO.	ITEM NO.
11/45				
PARTS LIST				
UNLESS OTHERWISE SPECIFIED DIMENSION IN INCHES TOLERANCES		DRN: <i>Walt</i>	DATE: 12-27-71	<p>DIGITAL EQUIPMENT CORPORATION MAYNARD, MASSACHUSETTS</p>
DECIMALS	ANGLES	CHK: <i>Walt</i>	DATE: 7/1/71	
.XXX - .005	± 0° 30'	ENG: <i>Walt</i>	DATE: 3/25/72	
.XX - .02		PROJ. ENG: <i>Walt</i>	DATE: 3/28/72	
REMOVE URRS AND BP: AK SHARP CORNER: SURFACE QUALITY		PROD: <i>Walt</i>	DATE: 3-30-72	
MATERIAL	NEXT HIGHER ASSY.	TITLE: 11/45 CONSOLE BOARD		
FINISH	SCALE: 3 OF 4	SIZE CODE: DCS 5409684-0-1	NUMBER: H	REV: H

REVISIONS  
 CHANGE NO.  
 REV.

This drawing and specifications herein are the property of Digital Equipment Corporation and shall not be reproduced or copied or used in whole or in part as the basis for the manufacture or sale of items without written permission.

CODE SELECT LINES	AZ	AI	AD
USER I.V.	1	1	1
USER D.V.	1	1	0
SUPER I.V.	1	0	1
SUPER D.V.	1	0	0
KERNEL I.V.	0	1	0
KERNEL D.V.	0	0	1
PROGRAM PHY	0	0	0
CONSOLE PHY	0	1	1

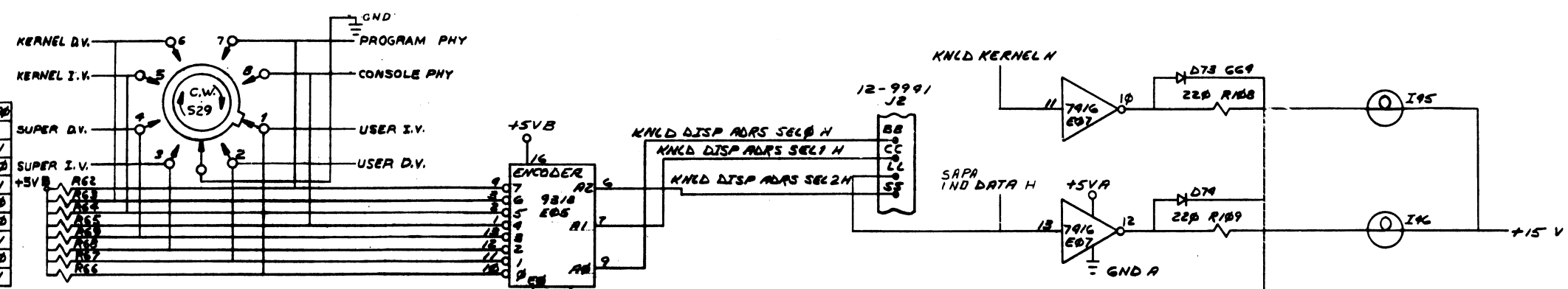

CODE SELECT LINES	DATA SEL1	DATA SEL0
BUS REGISTER	0	0
DATA PATHS	0	1
DISPLAY REGISTER	1	0
M ADRES FOR CPU	1	1

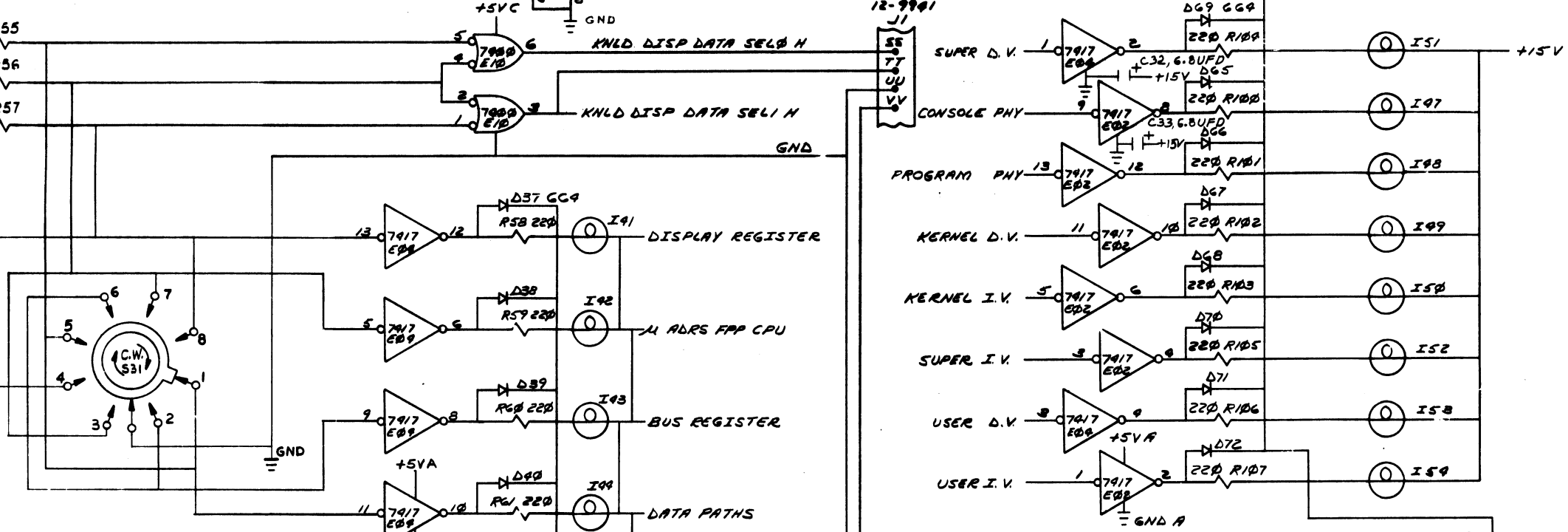

CODE SELECT LINES	DATA SEL1	DATA SEL0
BUS REGISTER	0	0
DATA PATHS	0	1
DISPLAY REGISTER	1	0
M ADRES FOR CPU	1	1

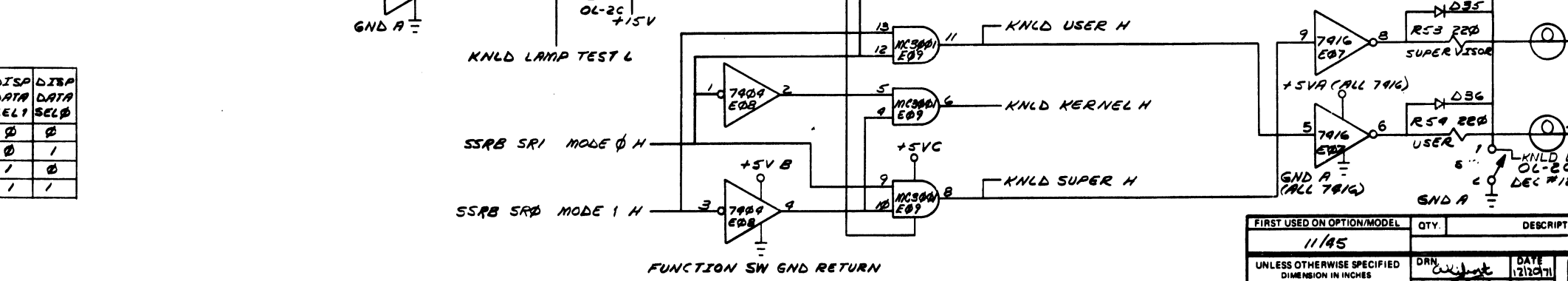

REV	CHANGE NO	REVISIONS

FIRST USED ON OPTION/MODEL	QTY.	DESCRIPTION	PART NO	TITLE
11/45				
UNLESS OTHERWISE SPECIFIED DIMENSION IN INCHES TOLERANCES				
DECIMALS	ANGLES	TITLE		
.XX - .006	10° 30'	11/45 CONSOLE BOARD		
.XX - .02		KNLD		
.X - .1		NUMBER		
REMOVE BURRS AND BREAK SHARP CORNERS SURFACE QUALITY		NEXT HIGHER ASSY.		REV.
MATERIAL		B-00-11/45-0		M
FINISH		SCALE		
		SHEET 4 OF 4		

## CUSTOMER PRINT SET INDEX

THIS IS PRINT SET   

SEQUENCE	SEQUENCE
DRAWING DIRECTORY (SHT 1 ONLY)	B-DD-KB11-A-0
MODULE UTILIZATION	E-MU-KB11-A-1
BLOCK DIAGRAM	D-BD-KB11-A-02
KB11-A FLOW DIAGRAMS	D-FD-KB11-A-03
DATA PATHS (DAP)	E-CS-M8100-0-1
GENERAL REGS & ALU CNTL (GRA)	E-CS-M8101-0-1
IR DECODE & COND CODES (IRC)	E-CS-M8102-0-1
ROM & ROM CONTROL (RAC)	E-CS-M8103-0-1
PROC DATA & UNIBUS REG (PDR)	E-CS-M8104-0-1
TRAP & MISC CNTL (TMC)	E-CS-M8105-0-1
UNIBUS & CONSOLE CNTL (UBC)	E-CS-M8106-0-1
TIMING GENERATOR (TIG)	E-CS-M8109-0-1
SYSTEM JUMPER BOARD (SJB)	E-CS-M8116-0-1
BUS CABLES & GRANT CHAIN	D-IC-KB11-A-BG
CIRCUIT SCHEMATIC	C-CS-M930-0-1
CIRCUIT SCHEMATIC	C-CS-M9202-0-1
CIRCUIT SCHEMATIC	E-CS-5409910-0-1
CIRCUIT SCHEMATIC (TIG)	E-CS-5409912-0-1
SPECIAL REVISION	E-CS-M8109-0-1

UNIT VARIATIONS		PRINT SET		
VAR	TITLE	KB11-1		
KB11-A	16 BIT PROCESSOR	X		

REVISIONS DATE    CHG. NO.    REV 4/76    11/45-00065    AA REVISED & REDRAWN	USED ON OPTION/MODEL	DRN. R. COOK CHK'D. R. COOK PROJ ENG. B. A. DELAY PRD. A. HUSCH FIELD SERV. A. ZINA	DATE MAR-72 DATE MAR-72 DATE APR 72 DATE MAY 72 DATE MAY 72	TITLE 16 BIT PROCESSOR	SIZE	CODE	NUMBER	REV
					B	DD	KB11-A-0	AA
	SHEET 1 OF 5				DIST			

EN-01062-1A-16-R972(325)

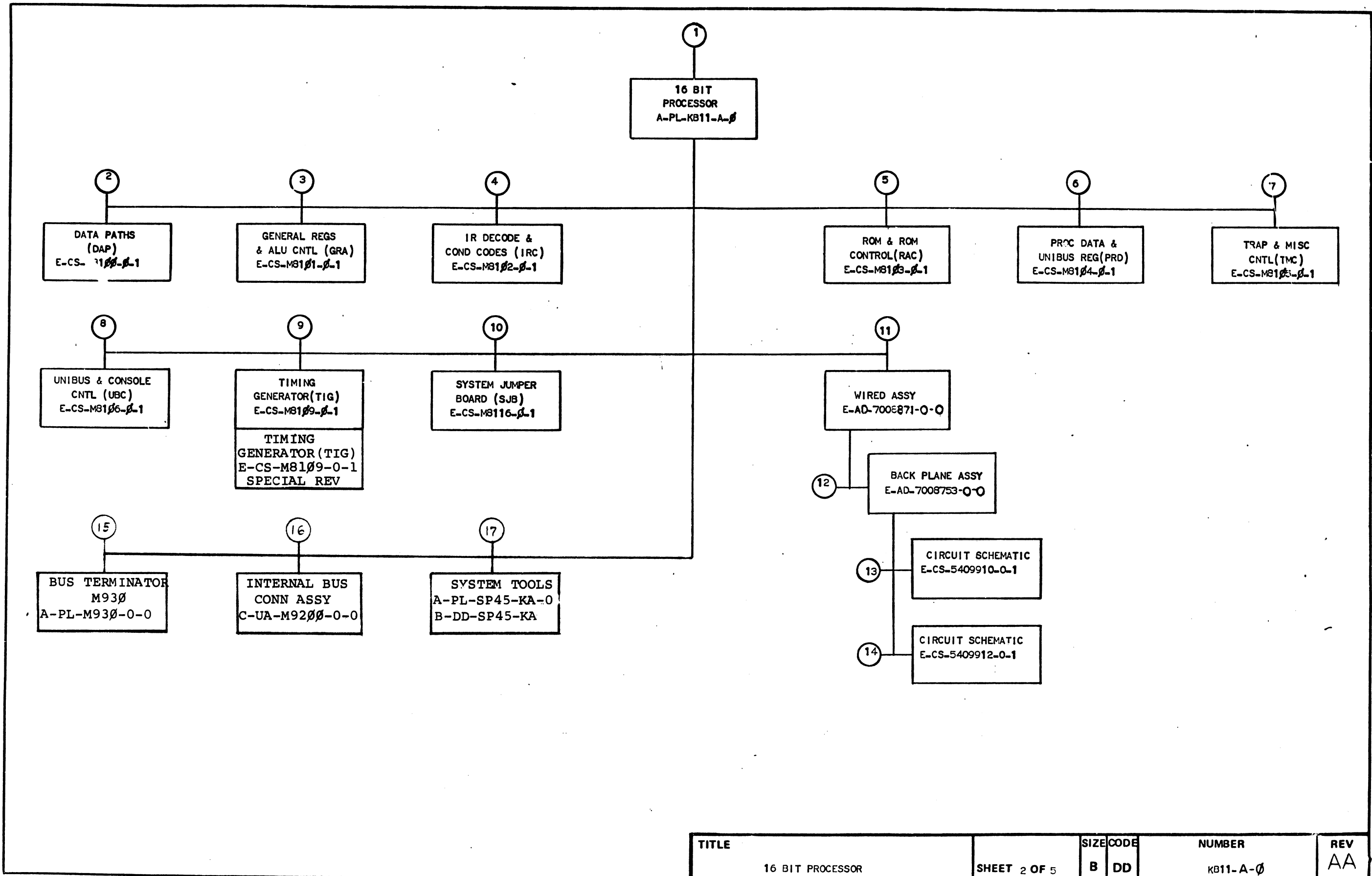

TITLE	SHEET	SIZE	CODE	NUMBER	REV
16 BIT PROCESSOR	2 OF 5	B	DD	KB11-A-0	AA

# DRAWING DIRECTORY

"THIS DRAWING AND SPECIFICATIONS, HEREIN, ARE THE PROPERTY OF DIGITAL EQUIPMENT CORPORATION AND SHALL NOT BE REPRODUCED OR COPIED OR USED IN WHOLE OR IN PART AS THE BASIS FOR THE MANUFACTURE OR SALE OF ITEMS WITHOUT WRITTEN PERMISSION. COPYRIGHT © 1975, DIGITAL EQUIPMENT CORPORATION"

## CUSTOMER PRINT SET INDEX

THIS IS PRINT SET

SEQUENCE	SEQUENCE
DRAWING DIRECTORY	B-DD-KB11-D (SHEETS 1 & 2 ONLY)
MODULE UTILIZATION	E-MU-KB11-D-1
BUS CABLES & GRANT CHAIN	D-IC-KB11-A-BG
BLOCK DIAGRAM	D-BD-KB11-D-2
KB11-C FLOW DIAGRAMS	D-FD-KB11-C-3
DATA PATHS (DAP)	E-CS-M8100-0-1
GEN REG & ALU CONTROL (GRA)	E-CS-M8101-0-1
IR DECODE & COND. CODES (IRC)	E-CS-M8132-0-1
ROM & ADDR CONTROL (RAC)	E-CS-M8123-0-1
PROC DATA & UNIBUS REG (PDR)	D-CS-M8104-0-1
TRAP & MISC CONTROL (TMC)	E-CS-M8105-0-1
UNIBUS & CONSL. CONTROL (UBC)	E-CS-M8119-0-1
TIMING GENERATOR	E-CS-M8109-0-1
SYSTEM JUMPER BOARD	D-CS-M8116-0-1
CIRCUIT SCHEMATIC	C-CS-M930-0-1
CIRCUIT SCHEMATIC	C-CS-M920-0-1
CIRCUIT SCHEMATIC	E-CS-5409910-0-1
CIRCUIT SCHEMATIC	E-CS-5409912-0-1

UNIT VARIATIONS		PRINT SET	
VAR	TITLE	1	
KB11-D	16 BIT PROCESSOR	X	

REVISIONS	CHG. NO.	REV
7-76	11/55-1	A

USED ON OPTION/MODEL	ORN.	DATE	TITLE	SIZE	CODE	NUMBER	REV
11/45	D. HEALY	12/30/75	16 BIT PROCESSOR	B	DD	KB11-D	A
11/55	D. HEALY	12/30/75					
	PROJ. ENG. <i>Daryl B. Borestein</i>	4 JAN '76					
	PROD. <i>D. Borestein</i>	7 FEB 76					
	FIELD SERV. <i>C. Lynch</i>	5 FEB 76					
SHEET 1 OF 5							

EN-01062-1A-16-R97Z-(325)

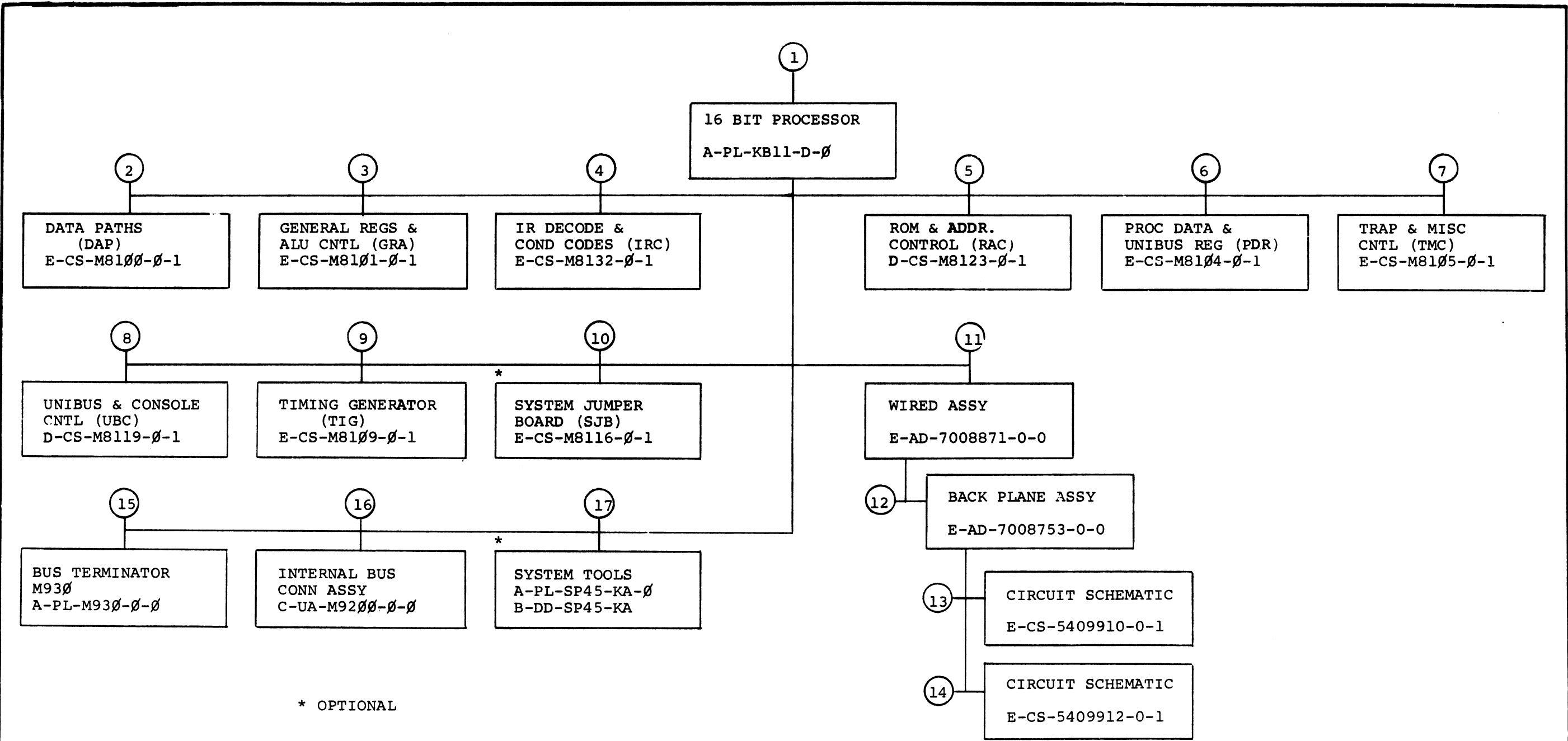

\* OPTIONAL

TITLE	SHEET	SIZE	CODE	NUMBER	REV
16 BIT PROCESSOR	2 OF 5	B		KB11-D	A

# DRAWING DIRECTORY

"THIS DRAWING AND SPECIFICATIONS, HEREIN, ARE THE PROPERTY OF DIGITAL EQUIPMENT CORPORATION AND SHALL NOT BE REPRODUCED OR COPIED OR USED IN WHOLE OR IN PART AS THE BASIS FOR THE MANUFACTURE OR SALE OF ITEMS WITHOUT WRITTEN PERMISSION. COPYRIGHT © 1976, DIGITAL EQUIPMENT CORPORATION"

## CUSTOMER PRINT SET INDEX

THIS IS PRINT SET

SEQUENCE  $\gamma$   
PRINT SET #1  
DRAWING DIRECTORY  
ASYNCHRONOUS LINE INTERFACE  
ASYNCHRONOUS LINE INTERFACE (PL)  
ASYNCHRONOUS LINE INTERFACE  
ASYNCHRONOUS LINE INTERFACE  
CABLE ASSEMBLY (KL8/E)  
SOFTWARE LIST  
ACCESSORY LIST  
INSTALLATION PROCEDURE

SEQUENCE  $\gamma$   
PRINT SET #3  
DRAWING DIRECTORY  
ASYNCHRONOUS LINE INTERFACE  
ASYNCHRONOUS LINE INTERFACE (PL)  
ASYNCHRONOUS LINE INTERFACE  
ASYNCHRONOUS LINE INTERFACE  
CABLE, MODEM BC05C  
CABLE ASSEMBLY (KL81E)  
MODEM TEST CONN.  
INSTALLATION PROCEDURE

B-DD-DL11-0  
C-UA-DL11-0-0  
A-PL-DL11-0-0  
E-CS-M7800-0-1  
D-IA-7008360-0-0  
A-SL-DL11-0-4  
A-AL-DL11-0-5  
A-SP-DL11-0-2  
B-DD-DL11-0  
C-UA-DL11-0-0  
(PL) A-PL-DL11-0-0-0  
E-CS-M7800-0-1  
D-UA-BC05C-0-0  
D-IA-7008360-0-0  
D-CS-H315-0-1  
A-SP-DL11-0-2

PRINT SET #2  
DRAWING DIRECTORY  
ASYNCHRONOUS LINE INTERFACE  
ASYNCHRONOUS LINE INTERFACE (PL)  
ASYNCHRONOUS LINE INTERFACE  
CABLE, MODEM BC05C  
FILTER NETWORK  
MODEM TEST CONN  
SOFTWARE LIST  
ACCESSORY LIST  
INSTALLATION PROCEDURE

B-DD-DL11-0  
C-UA-DL11-0-0  
A-PL-DL11-0-0  
E-CS-M7800-0-1  
D-UA-BC05C-0-0  
B-CS-G8000-0-1  
D-CS-H315-0-1  
A-SL-DL11-0-4  
A-AL-DL11-0-5  
A-SP-DL11-0-2

VAR	TITLE	PRINT SET	
		DL11-1	DL11-2
DL11-A	ASYNC LINE INTERFACE, CURRENT LOOP	1	0
DL11-B	ASYNC LINE INTERFACE, EIA	0	1
DL11-C	ASYNC LINE INTERFACE, CURRENT LOOP	1	0
DL11-D	ASYNC LINE INTERFACE, EIA	0	1
DL11 E	ASYNC LINE INTERFACE, DATA SET	0	1

REV	K
CHG. NO.	DL11-0009
DATE	2-76
REVISIONS	REDRAWN

USED ON OPTION/MODEL	DRN.	DATE	TITLE	NUMBER	REV			
	M. Pierce	4-28-72				ASYNC LINE INTERFACE	DL11-0	K
	CHK'D.	DATE						
	R. Cook	5-9-72						
	PROJ ENG.	DATE						
	P. E. Janson	5-11-72						
	PROD.	DATE	SIZE	CODE				
	J. McIntyre	5-15-72	B	DD				
	FIELD SERV.	DATE	DIST					
	R. Evans	5-15-72						
SHEET	OF	3						

EN-01062-1A-16-R972-(325)

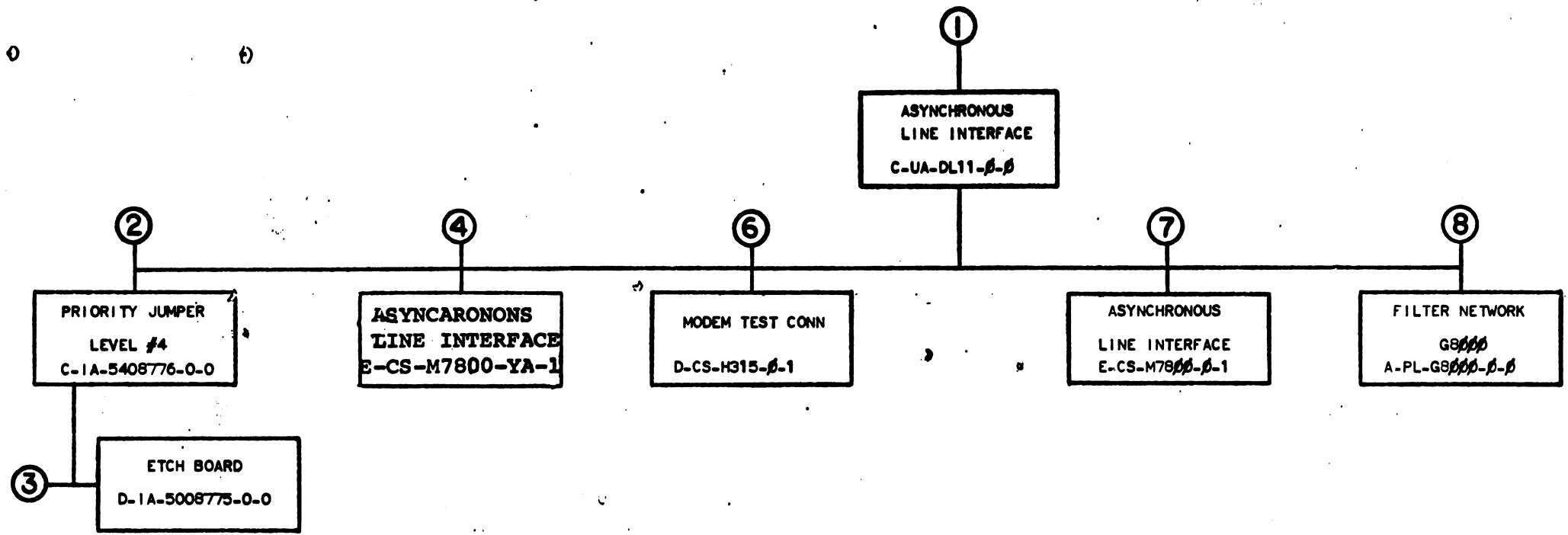

TITLE	ASYNCHRONOUS LINE INTERFACE	SHEET 2 OF 3	SIZE CODE B DD	NUMBER DL11-Ø	REV K
-------	--------------------------------	--------------	-------------------	------------------	----------

CUSTOMER PRINT SET				ELECTRICAL					CUSTOMER PRINT SET				MECHANICAL							
DL11-1	DL11-2	DL11-3	DEPOT SET	FIND NO.	DRAWING NO.	REV	NO OF SHT	DESCRIPTION	OPTION NO.	DL11-1	DL11-2	DL11-3	DEPOT SET	FIND NO.	DRAWING NO.	REV	NO OF SHT	DESCRIPTION	OPTION NO.	
X	X	X		1.	C-UA-DL11-β-β	F	1	ASYNCHRONOUS LINE INTERFACE						1.	C-UA-DL11-β-β	F	1	ASYNCHRONOUS LINE INTERFACE		
X	X	X			A-PL-DL11-β-β	F	1	ASYNCHRONOUS LINE INTERFACE (PL)							A-PL-DL11-β-β	F	1	ASYNCHRONOUS LINE INTERFACE (PL)		
	X	X			D-UA-BCβ5C-β-β	#	1	CABEE, MODEM, BCβ5C							D-UA-BCβ5C-β-β		1	CABLE, MODEM BCβ5C		
X		X			D-IA-7008360-0-0	#	1	CABLE, ASSEMBLY (KL8/E)							D-IA-7008360-0-0		1	CABLE ASSEMBLY (KL8/E)		
	X	X			A-SP-DL11-β-1	*	11	ENGINEERING SPECIFICATION												
X	X	X			A-SP-DL11-β-2	F	9	INSTALLATION PROCEDURE												
	X	X			A-SP-DL11-β-3	B	8	TEST PROEDURE (TEST & ACCEPTANCE)												
X	X				A-SL-DL11-β-4	*	1	SOFTWARE LIST												
X	X				A-AL-DL11-β-5	C	1	ACCESSORY LIST												
				2.	C-IA-5408776-0-0		1	PRIORITY JUMPER LEVEL #4						2.	C-IA-5408776-0-0		1	PRIORITY JUMPER LEVEL #4		
					B-CS-5408776-0-1		1	CIRCUIT SCHEMATIC							K-CO-5408776-0-4		1	X-Y COORDINATE HOLE LOC		
					K-CO-5408776-0-4		1	X-Y COORDINATE HOLE LOC							B-MH-5408776-0-6		1	ASSY/DRILLING HOLE LAYOUT		
					B-MH-5408776-0-6		1	MODULE ECO HISTORY												
				3.	C-AH-5408776-0-5		1	ASSY/DRILLING HOLE LAYOUT						3.	D-IA-5008775-0-0		1	ETCH BOARD		
															C-AH-5408776-0-5		1	ASSY/DRILLING HOLE LAYOUT		
X				4.	E-CS-M7800-YA-1	#	6	ASYNCHRONOUS LINE INTERFACE												
					K-CO-M7800-YA-4		1	X-Y COORDINATE HOLE LOCATION												
					D-AH-M7800-YA-5		1	ASSY DRILLING HOLE LAYOUT												
					B-MH-M7800-YA-6		1	MODULE ECO HISTORY												
	X	X		6.	D-CS-H315-β-1	#	1	MODEM TEST CONN						6.	D-CS-H315-β-1		1	MODEM TEST CONN		
					K-CO-H315-β-4		1	X-Y COORDINATE HOLE LOC							K-CO-H315-β-4		1	X-Y COORDINATE HOLE LOC		
					D-AH-H315-β-5		1	ASSY DRILLING HOLE LAYOUT							C-AH-H315-β-5		1	ASSY/DRILLING HOLE LAYOUT		
					B-MH-H315-β-6		1	MODULE ECO HISTORY							B-MH-H315-β-6		1	MODULE ECO HISTORY		
X	X	X		7.	E-CS-M7800-β-1	#	7	ASYNCHRONOUS LINE INTERFACE						7.	E-CS-M7800-β-1		7	ASYNCHRONOUS LINE INTERFACE		
					K-CO-M7800-β-4		1	X-Y COORDINATE HOLE LOC							K-CO-M7800-β-4		1	X-Y COORDINATE HOLE LOC		
					D-AH-M7800-β-5		1	ASSY/DRILLING HOLE LAYOUT							D-AH-M7800-β-5		1	ASSY/DRILLING HOLE LAYOUT		
					B-MH-M7800-β-6		1	MODULE ECO HISTORY							B-MH-M7800-β-6		1	MODULE ECO HISTORY		
	X			8.	A-PL-G8000-β-β		1	FILTER NETWORK						8.	A-PL-G8000-β-β		1	FILTER NETWORK		
					B-CS-G8000-β-1	#	1	CIRCUIT SCHEMATIC							K-CO-G8000-β-4		1	X-Y COORDINATE HOLE LOC		
					K-CO-G8000-β-4		1	X-Y COORDINATE HOLE LOC							C-AH-G8000-β-5		1	ASSY/DRILLING HOLE LAYOUT		
					C-AH-G8000-β-5		1	ASSY/DRILLING HOLE LAYOUT							B-MH-G8000-β-6		1	MODULE ECO HISTORY		
					B-MH-G8000-β-6		1	MODULE ECO HISTORY												

TITLE	ASYNCHRONOUS LINE INTERFACE	SHEET 3 OF 3	SIZE	B	CODE	DD	NUMBER	DL11-0	REV	K
-------	-----------------------------	--------------	------	---	------	----	--------	--------	-----	---

G

This drawing and specifications, herein, are the property of Digital Equipment Corporation and shall not be reproduced or copied or used in whole or in part as the basis for the manufacture or sale of items without written permission.  
1972

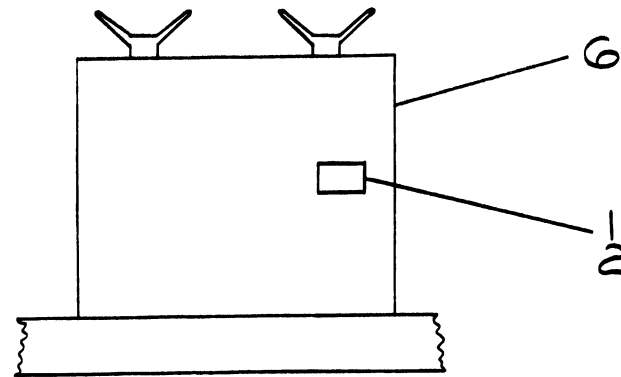

NOTES:

- G 8000 IS REQUIRED ONLY IN PDP 11 SYSTEMS WHERE +15V IS NOT AVAILABLE. THE INSTALLATION REQUIRES 2 WIRES TO BE ADDED.  
A03V2-A02V2  
A02N2-CXXUI  
WHERE (XX) IS THE SLOT NUMBER CONTAINING THE DLII.
- ITEMS INDICATED WITH ASTERICK (\*) ARE SHOWN FOR REFERENCE ONLY AND ARE NOT PART OF THIS UNIT.

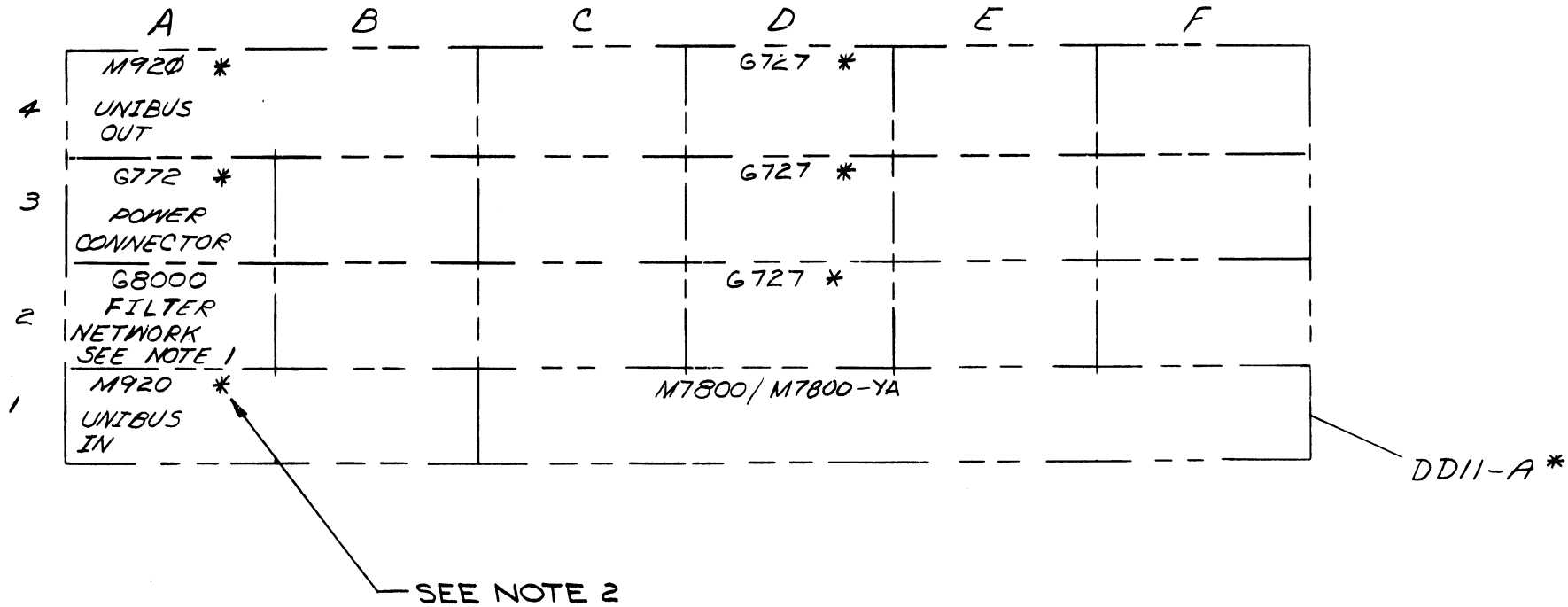

CHK	CHANGE NO.	REV.
P.M.	DLII-00001	A
	M. Desires 2-18-72	
	F. JANSON	
P.E.	JANSON 7-17-72	B
P.M.	DLII-00002	B
	P.R. Janson 11/14/72	
	JANSON	
P.M.	DLII-00005	C
	P.E. Janson 12-5-72	
	B. O. Langstaff 1-31-73	
	L. CONDON	
	DLII-00006	D
	J. Schacter 9-21-73	
	CONDON	
	DLII-00008	E
	E. Remond 4-4-75	
	L. CONDON	
	DLII-00009	F
	A. Basani 12-FEB-76	
	J. MCINTYRE	
	J. McE...	

FIRST USED ON OPTION/MODEL	QTY.	DESCRIPTION	PART NO.	ITEM NO.
PDP-11		PARTS LIST		
UNLESS OTHERWISE SPECIFIED DIMENSION IN INCHES. TOLERANCES	DRN. <i>M. Janson</i>	DATE 3/18/72		
DECIMALS .XXX = .005 .XX = .02 .X = .1	CHK'D. <i>M. Janson</i>	DATE 4-24-72		
ANGLES ±0° 30'	ENG. <i>P.E. Janson</i>	DATE 5-11-72	<b>ASYNCHRONOUS LINE INTERFACE</b>	
REMOVE BURRS AND BREAK SHARP CORNERS SURFACE QUALITY ✓	PROJ. ENG. <i>P.E. Janson</i>	DATE 5-11-72		
MATERIAL	PROD. <i>J. McIntyre</i>	DATE 5-15-72	SIZE CODE	NUMBER
FINISH	NEXT HIGHER ASSY.		C UA	DLII-0-0
	B-DD-DLII-0		DIST	G
	SCALE NONE			
	SHEET 1 OF 1			

DIGITAL EQUIPMENT CORPORATION MAYNARD, MASSACHUSETTS				QUANTITY / VARIATION														
PARTS LIST				DL11-A	DL11-B	DL11-C	DL11-D	DL11-E										
MADE BY M. PIERCE		CHECKED J. FERGUSON		SECTION														
DATE 4/27/72		DATE 4/27/72		1														
ENG P. E. JANSON		PROD <i>J. Mc Dyer</i>		ISSUED SECT.														
DATE 5/11/72		DATE 5/15/72		1														
ITEM NO.	DWG NO. / PART NO.	DESCRIPTION		DL11-A	DL11-B	DL11-C	DL11-D	DL11-E										
1	C-IA-5408776-0-0	PRIORITY JUMPER LEVEL #4		1	1	1	1	1										
3	D-UA-BC05C-25	CABLE MODEM BC05C		-	1	-	1	1										
4	D-IA-7008360-0-0	CABLE ASSEMBLY (KL8E)		1	-	1	-	-										
5	D-CS-H315-0-1	MODEM TEST CONNECTOR		-	-	-	-	A/R	See Note 2									
6	E-CS-M7800-0-1	ASYNCHRONOUS LINE INTERFACE		-	1	-	1	1										
7	<del>A-PL-G8000-0-0</del>	<del>FILTER NETWORK</del>		<del>= A/R = A/R A/R See Note 1</del>														
8		CRYSTAL		A/RA/RA/RA/RA/R See Note 3														
9	E-CS-M7800-YA-1	ASYNCHRONOUS LINE INTERFACE		1	-	1	-	-										
10	9008269	TRANSPARENT VINYL TAPE		A/R														
NOTES:																		
1. G8000 IS REQUIRED ONLY IN PDP11 SYSTEMS WHERE +15V IS NOT AVAILABLE. ONE PER DD11-A																		
2. ONE H315 PER PDP11 SYSTEM																		
3. CRYSTAL FREQUENCY DEFINED BY CUSTOMER SPECIFIED BAUD RATE OR BY THE DOCUMENTATION OF AN OPTION WHICH USES THE DL11.																		
4. APPLY TAPE TO TOP SURFACES OF CRYSTAL AND MOUNTING BRACKETS TO INSULATE FROM ADJACENT MODULES.																		
5. PRIORIY LEVELS 5, 6, or 7 MAY BE SPECIFIED BY THE CUSTOMER OR THE DOCUMENTATION OF AN OPTION WHICH USES THE DL11.																		
TITLE		ASSY NO.		SIZE CODE		NUMBER				REV.		ECO NO.						
ASYNCHRONOUS LINE INTERFACE		C-UA-DL11-0-0		A PL		DL11-0-0				F		DL11-00009						
		SHEET 1 OF 1		DIST.														

DIGITAL EQUIPMENT CORPORATION

NOTES:

- 1.) PIN NOTATION THROUGHOUT IS ORDERED UPON MODULE PLACEMENT IN THE SYSTEM UNIT. MODULE REFERENCE ALONE IS OBTAINED BY CONVERTING THE FIRST LETTER ACCORDING TO THE PIN NOMENCLATURE CHART AT THE LEFT.
- 2.) JUMPERS TO BE USED AT CONNECTIONS A3-A10, J4-J5, J8, J10, V3-V8, AND N1.
- 3.) LETTERS ENCLOSED IN PARENTHESIS REFER TO PINS ON THE BERG CONNECTOR. EXAMPLE: (X).
- 4.) DEC 8640S WERE PHASED IN AS 380 REPLACEMENTS ANY 380 FAILURES SHOULD BE REPLACED BY 8640'S, EXCEPT E28. E28 MUST BE REPLACED WITH A 7380 CHIP.

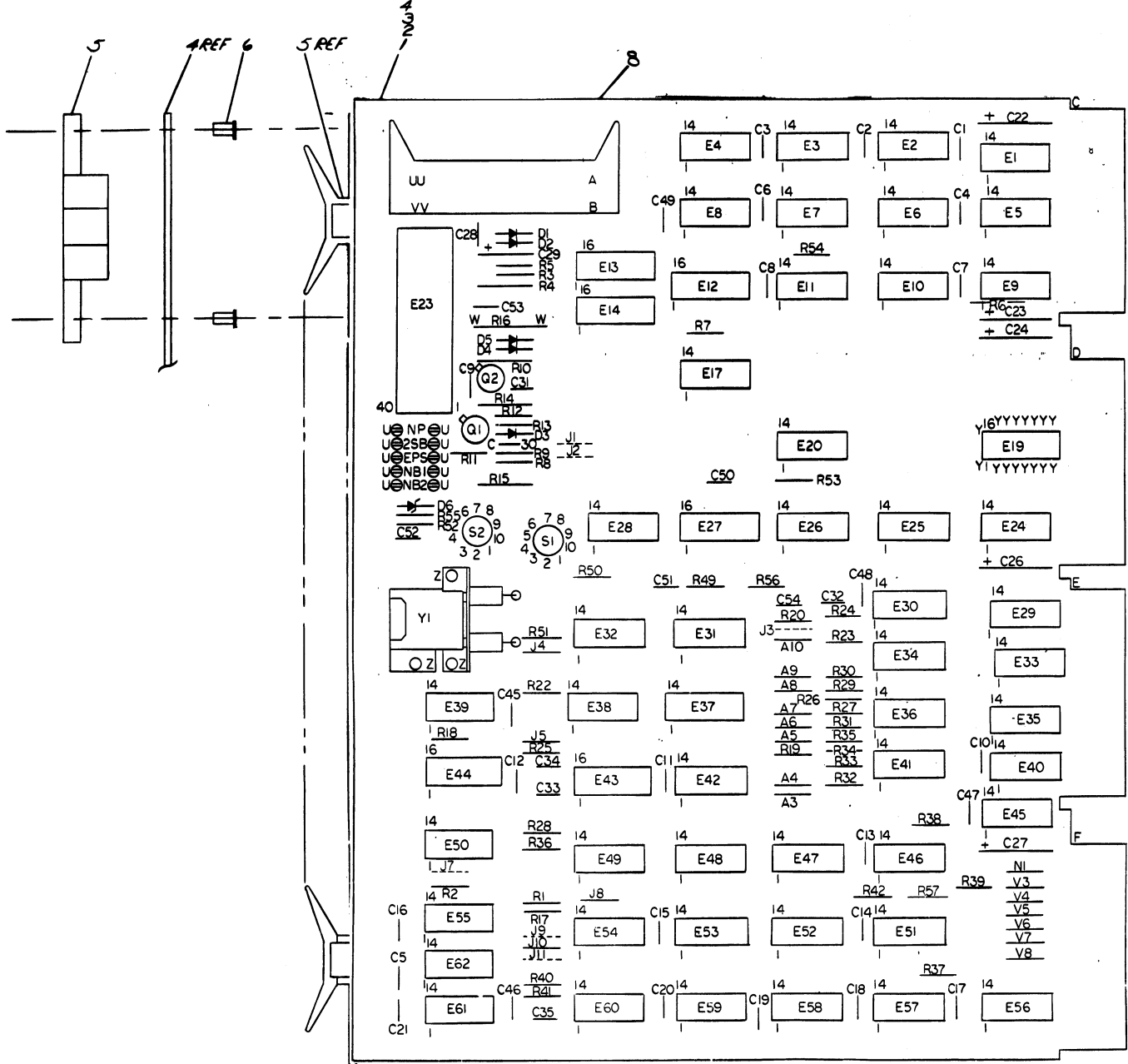

PIN NOMENCLATURE  
MODULE SYSTEM UNIT

QTY	REF DESIGNATION	DESCRIPTION	PART NO.
1	E28	WASHERS, INTERNAL TOOTH LOC	9004631
1	E28	IC DEC 7380	1910390
19	J1 THRU J19	JUMPER, INSULATED	7100411
1	R3	RES 750Ω 1/4W 5%	1301401
1	R38	RES 300Ω 1/4W 5%	1300301
1	D1	DIODE, 1N4148A	1103880
2	C1, C2	CAPACITOR, 100PF 50V 5%	1003810
1	C3	CAPACITOR, 100PF 50V 5%	1003810
2	C4, C5	CAPACITOR, 100PF 50V 5%	1003810
1	E27	IC DEC 74161	1910620
2	C34, C35	CAPACITOR, 100PF 50V 5%	1003810
1	C32	CAPACITOR, 100PF 50V 5%	1003810
1	C31	CAPACITOR, 100PF 50V 5%	1003810
27	R1, R2, R3, R4, R5, R6, R7, R8, R9, R10, R11, R12, R13, R14, R15, R16, R17, R18, R19, R20, R21, R22, R23, R24, R25, R26, R27, R28, R29, R30, R31, R32, R33, R34, R35, R36, R37, R38, R39, R40, R41, R42, R43, R44, R45, R46, R47, R48, R49, R50, R51, R52, R53, R54, R55, R56, R57	RESISTOR, 1/4W 5%	1300125
1	C22	CAPACITOR, 100PF 50V 5%	1003810
1	C23	CAPACITOR, 100PF 50V 5%	1003810
1	C24	CAPACITOR, 100PF 50V 5%	1003810
1	C26	CAPACITOR, 100PF 50V 5%	1003810
1	C27	CAPACITOR, 100PF 50V 5%	1003810
1	C28	CAPACITOR, 100PF 50V 5%	1003810
1	C29	CAPACITOR, 100PF 50V 5%	1003810
1	C30	CAPACITOR, 100PF 50V 5%	1003810
1	C31	CAPACITOR, 100PF 50V 5%	1003810
1	C32	CAPACITOR, 100PF 50V 5%	1003810
1	C33	CAPACITOR, 100PF 50V 5%	1003810
1	C34	CAPACITOR, 100PF 50V 5%	1003810
1	C35	CAPACITOR, 100PF 50V 5%	1003810
1	C36	CAPACITOR, 100PF 50V 5%	1003810
1	C37	CAPACITOR, 100PF 50V 5%	1003810
1	C38	CAPACITOR, 100PF 50V 5%	1003810
1	C39	CAPACITOR, 100PF 50V 5%	1003810
1	C40	CAPACITOR, 100PF 50V 5%	1003810
1	C41	CAPACITOR, 100PF 50V 5%	1003810
1	C42	CAPACITOR, 100PF 50V 5%	1003810
1	C43	CAPACITOR, 100PF 50V 5%	1003810
1	C44	CAPACITOR, 100PF 50V 5%	1003810
1	C45	CAPACITOR, 100PF 50V 5%	1003810
1	C46	CAPACITOR, 100PF 50V 5%	1003810
1	C47	CAPACITOR, 100PF 50V 5%	1003810
1	C48	CAPACITOR, 100PF 50V 5%	1003810
1	C49	CAPACITOR, 100PF 50V 5%	1003810
1	C50	CAPACITOR, 100PF 50V 5%	1003810
1	C51	CAPACITOR, 100PF 50V 5%	1003810
1	C52	CAPACITOR, 100PF 50V 5%	1003810
1	C53	CAPACITOR, 100PF 50V 5%	1003810
1	C54	CAPACITOR, 100PF 50V 5%	1003810
1	C55	CAPACITOR, 100PF 50V 5%	1003810
1	C56	CAPACITOR, 100PF 50V 5%	1003810
1	C57	CAPACITOR, 100PF 50V 5%	1003810
1	C58	CAPACITOR, 100PF 50V 5%	1003810
1	C59	CAPACITOR, 100PF 50V 5%	1003810
1	C60	CAPACITOR, 100PF 50V 5%	1003810
1	C61	CAPACITOR, 100PF 50V 5%	1003810
1	C62	CAPACITOR, 100PF 50V 5%	1003810
1	C63	CAPACITOR, 100PF 50V 5%	1003810
1	C64	CAPACITOR, 100PF 50V 5%	1003810
1	C65	CAPACITOR, 100PF 50V 5%	1003810
1	C66	CAPACITOR, 100PF 50V 5%	1003810
1	C67	CAPACITOR, 100PF 50V 5%	1003810
1	C68	CAPACITOR, 100PF 50V 5%	1003810
1	C69	CAPACITOR, 100PF 50V 5%	1003810
1	C70	CAPACITOR, 100PF 50V 5%	1003810
1	C71	CAPACITOR, 100PF 50V 5%	1003810
1	C72	CAPACITOR, 100PF 50V 5%	1003810
1	C73	CAPACITOR, 100PF 50V 5%	1003810
1	C74	CAPACITOR, 100PF 50V 5%	1003810
1	C75	CAPACITOR, 100PF 50V 5%	1003810
1	C76	CAPACITOR, 100PF 50V 5%	1003810
1	C77	CAPACITOR, 100PF 50V 5%	1003810
1	C78	CAPACITOR, 100PF 50V 5%	1003810
1	C79	CAPACITOR, 100PF 50V 5%	1003810
1	C80	CAPACITOR, 100PF 50V 5%	1003810
1	C81	CAPACITOR, 100PF 50V 5%	1003810
1	C82	CAPACITOR, 100PF 50V 5%	1003810
1	C83	CAPACITOR, 100PF 50V 5%	1003810
1	C84	CAPACITOR, 100PF 50V 5%	1003810
1	C85	CAPACITOR, 100PF 50V 5%	1003810
1	C86	CAPACITOR, 100PF 50V 5%	1003810
1	C87	CAPACITOR, 100PF 50V 5%	1003810
1	C88	CAPACITOR, 100PF 50V 5%	1003810
1	C89	CAPACITOR, 100PF 50V 5%	1003810
1	C90	CAPACITOR, 100PF 50V 5%	1003810
1	C91	CAPACITOR, 100PF 50V 5%	1003810
1	C92	CAPACITOR, 100PF 50V 5%	1003810
1	C93	CAPACITOR, 100PF 50V 5%	1003810
1	C94	CAPACITOR, 100PF 50V 5%	1003810
1	C95	CAPACITOR, 100PF 50V 5%	1003810
1	C96	CAPACITOR, 100PF 50V 5%	1003810
1	C97	CAPACITOR, 100PF 50V 5%	1003810
1	C98	CAPACITOR, 100PF 50V 5%	1003810
1	C99	CAPACITOR, 100PF 50V 5%	1003810
1	C100	CAPACITOR, 100PF 50V 5%	1003810

IC TYPE	QTY	REF	DESCRIPTION
DEC 74161	8	16	
DEC 7380	1	8	
DEC UART	3	1	
DEC 74175	8	16	
DEC 8640	1	8	
DEC 74182	8	16	
DEC 314	1	8	
DEC 7493	10	5	
DEC 7492	10	5	
DEC 74153	8	16	
DEC 8640	1	8	
DEC 7490	10	5	
DEC 74183	8	16	

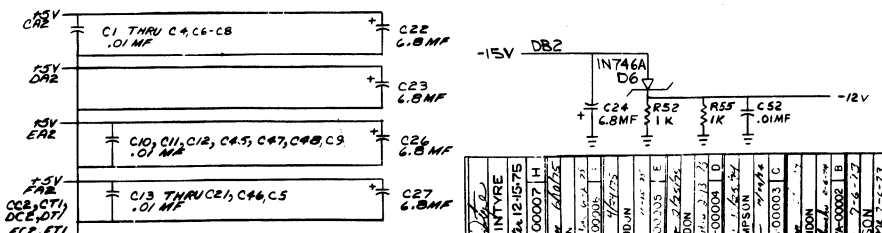

ETCH BOARD REV H

DEC NO.	EIA NO.	DEC NO.	EIA NO.
6340	MP5629		
IN746A	1/4W 3.3A		
0668	1N3606		

SEMICONDUCTOR CONVERSION CHART

IC PIN LOCATIONS

IC TYPE	QTY	REF	DESCRIPTION
DEC 74161	8	16	
DEC 7380	1	8	
DEC UART	3	1	
DEC 74175	8	16	
DEC 8640	1	8	
DEC 74182	8	16	
DEC 314	1	8	
DEC 7493	10	5	
DEC 7492	10	5	
DEC 74153	8	16	
DEC 8640	1	8	
DEC 7490	10	5	
DEC 74183	8	16	

EQUIPMENT CORPORATION

ASYNCHRONOUS LINE INTERFACE

CS 178200-YA-1

This drawing and specifications, when used in conjunction with the drawings and specifications of the equipment, shall constitute the entire contract. No part of this drawing shall be reproduced or transmitted in any form or by any means, electronic, mechanical, photocopying, recording, or by any information storage and retrieval system, without permission in writing from Digital Equipment Corporation.

DIGITALEQUIPMENT CORPORATION.

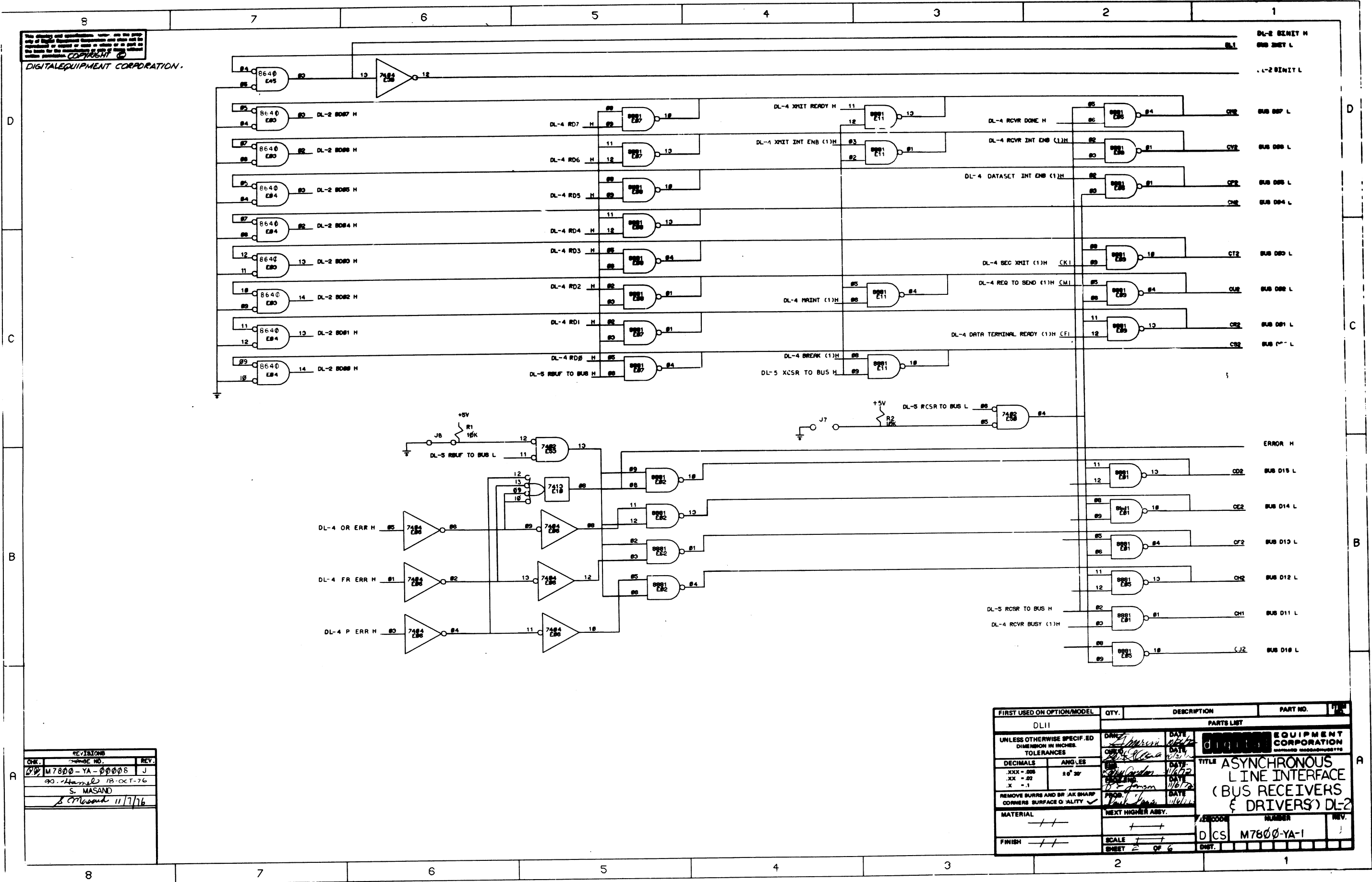

REVISIONS		
CHR.	CHANGE NO.	REV.
W	M7800-YA-00005	J
90. Hamel 18 OCT-76		
S. MASAND		
S. Masand 11/7/76		

FIRST USED ON OPTION/MODEL	QTY.	DESCRIPTION	PART NO.								
DL11											
UNLESS OTHERWISE SPECIFIED DIMENSION IN INCHES TOLERANCES		<table border="1"> <tr> <td>DRAWN</td> <td>DATE</td> </tr> <tr> <td>CHECKED</td> <td>DATE</td> </tr> <tr> <td>DESIGNED</td> <td>DATE</td> </tr> <tr> <td>PROOF</td> <td>DATE</td> </tr> </table>		DRAWN	DATE	CHECKED	DATE	DESIGNED	DATE	PROOF	DATE
DRAWN	DATE										
CHECKED	DATE										
DESIGNED	DATE										
PROOF	DATE										
DECIMALS	ANGLES	TITLE ASYNCHRONOUS LINE INTERFACE (BUS RECEIVERS & DRIVERS) DL-2									
.XXX - .005	±0° 30'	EQUIPMENT CORPORATION									
.XX - .02		PARTS LIST									
.X - .1		<table border="1"> <tr> <th>REV. CODE</th> <th>NUMBER</th> <th>REV.</th> </tr> <tr> <td>DCS</td> <td>M7800-YA-1</td> <td>1</td> </tr> </table>		REV. CODE	NUMBER	REV.	DCS	M7800-YA-1	1		
REV. CODE	NUMBER	REV.									
DCS	M7800-YA-1	1									
REMOVE BURRS AND BREAK SHARP CORNERS SURFACE QUALITY		MATERIAL									
FINISH		NEXT NUMBER ASSY.									
SCALE		SHEET									
OF 6		OF 6									

The drawings and specifications herein are the property of Digital Equipment Corporation. They are to be used only for the equipment and for the quantities of material specified in the drawings. No part of this document may be reproduced or transmitted in any form or by any means electronic or mechanical, including photocopying and recording, or by any information storage or retrieval system, without the prior written permission of Digital Equipment Corporation.

DIGITAL EQUIPMENT CORPORATION

SEE NOTE 3

Y1	844.8 KHZ		103296 MHZ		1.52 MHZ		4.608MHZ	
	BAUD	USEC	BAUD	USEC	BAUD	USEC	BAUD	USEC
1	36.7	1700	448	1342	50	1250	200	312
2	55	1135	673	928	75	833	300	208
3	110	567	1345	464	150	417	600	104
4	220	284	269	232	300	208	1200	52
5	440	142	538	116	600	104	2400	26
6	880	71	1076	58	1200	52	4800	13
7	1320	47.4	1614	38.7	1800	34.6	7200	8.7
8	1760	35.5	2152	29	2400	26	9600	6.5
9	BERG CLOCK INPUT - COMMON TO RCVR AND XMIT							
10	EXTERNAL CLOCK INPUT - RCVR: DSI; XMIT: ORI							

DL-3	DL-6	BUS BGA	BUS BGS	BUS BG4	BUS BG5	BUS BG6
DL-3 00 IN H	DL-6 00 OUT H	BUS BGA OUT H	BUS BGS OUT H	BUS BG4 IN H	BUS BGS IN H	BUS BG6 OUT H
DL-3 00 IN L	DL-6 00 OUT L	BUS BGA OUT L	BUS BGS OUT L	BUS BG4 IN L	BUS BGS IN L	BUS BG6 OUT L
DL-3 00 IN H	DL-6 00 OUT H	BUS BGA IN H	BUS BGS IN H	BUS BG4 OUT H	BUS BGS OUT H	BUS BG6 IN H
DL-3 00 IN L	DL-6 00 OUT L	BUS BGA IN L	BUS BGS IN L	BUS BG4 OUT L	BUS BGS OUT L	BUS BG6 IN L

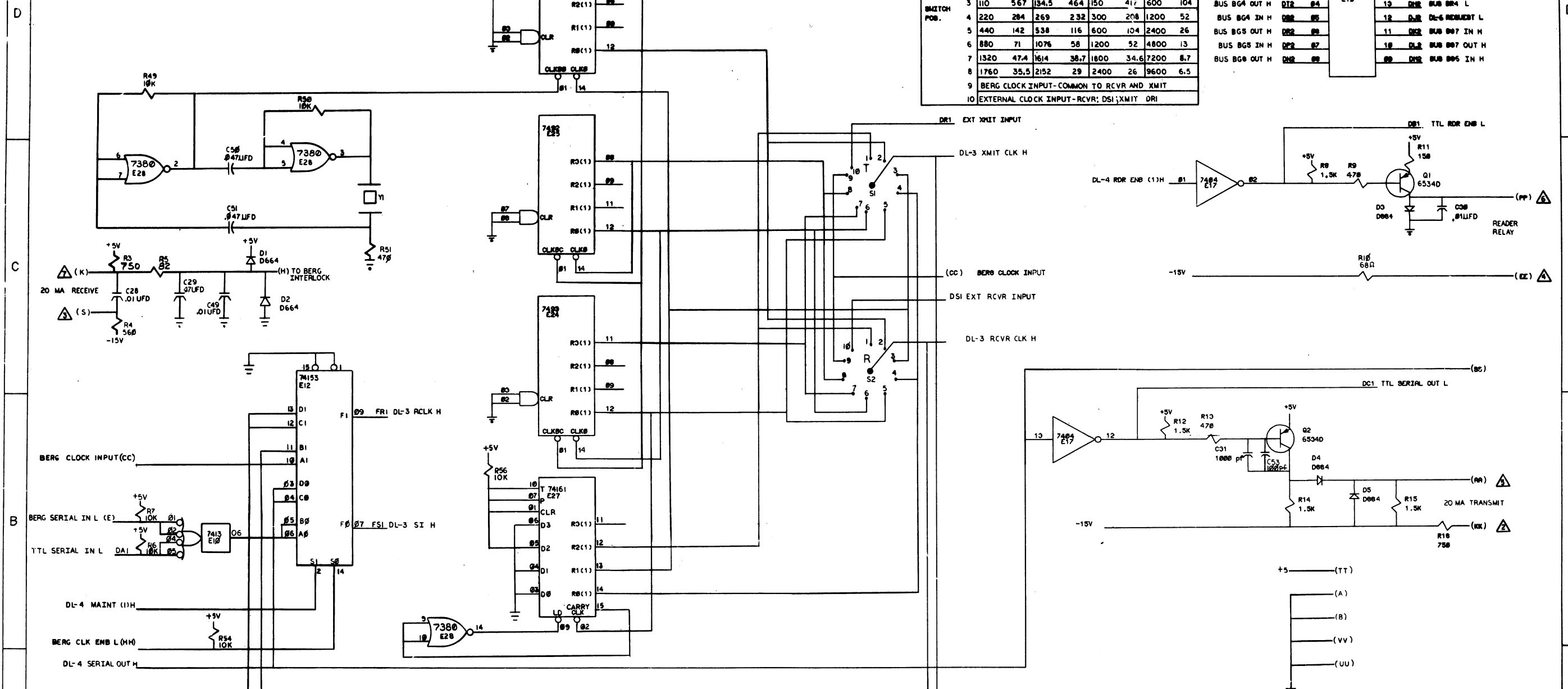

NOTES:  
 1. LETTERS ENCLOSED IN PARENTHESIS REFER TO PINS ON THE BERG CONNECTOR. EXAMPLE: (X)  
 2. NUMBERS WITHIN TRIANGLES REFER TO PINS ON THE FEMALE MATE-N-LOCK CONNECTOR WHEN USING THE 7008360 CABLE. THIS CABLE ALSO CONNECTS BERG PINS H TO E.  
 3. ALTHOUGH THE ABOVE TABLE INCLUDES ONLY THE STANDARD DL11 CRYSTALS OTHER VALUES MAY BE SPECIFIED BY THE CUSTOMER OR BY OTHER DOCUMENTATION OF AN OPTION WHICH USES THE DL11.

FIRST USED ON OPTION/MODEL	QTY.	DESCRIPTION	PART NO.
DL11			
UNLESS OTHERWISE SPECIFIED DIMENSION IN INCHES TOLERANCES			
DECIMALS	ANGLES	EQUIPMENT CORPORATION	
.XXX - .008	±0° 30'	TITLE A SYNCHRONOUS LINE INTERFACE (CLOCK & CURRENT LOOPS) DL-3	
.XX - .02		MATERIAL	
.X - .1		FINISH	
REMOVE BURRS AND BREAK SHARP CORNERS SURFACE QUALITY			
NEXT HIGHER ASSY.			
SCALE			
SHEET 3 OF 6			
D CS M7800-YA-1			

REV.	CHG. NO.	REV.



This drawing and specifications, herein, are the property of Digital Equipment Corporation and shall not be reproduced or copied in whole or in part in any form or by any means without the prior written permission of Digital Equipment Corporation.

DIGITAL EQUIPMENT CORPORATION.

- BUS A11 L E1 11
- BUS A10 L E2 12
- BUS A14 L E3 13
- BUS A15 L E4 14
- BUS A16 L E5 15
- BUS A17 L E6 16
- BUS A12 L E7 17

- BUS A18 L EP1 11
- BUS A20 L E21 12
- BUS A22 L E22 13
- BUS A27 L E27 14
- BUS A28 L E28 15
- BUS A25 L E25 16
- BUS A24 L E24 17
- BUS A23 L E23 18
- BUS A21 L E21 19
- BUS A22 L E22 20
- BUS A21 L E21 21
- BUS A22 L E22 22
- BUS C1 L E2 11
- BUS C2 L E2 12

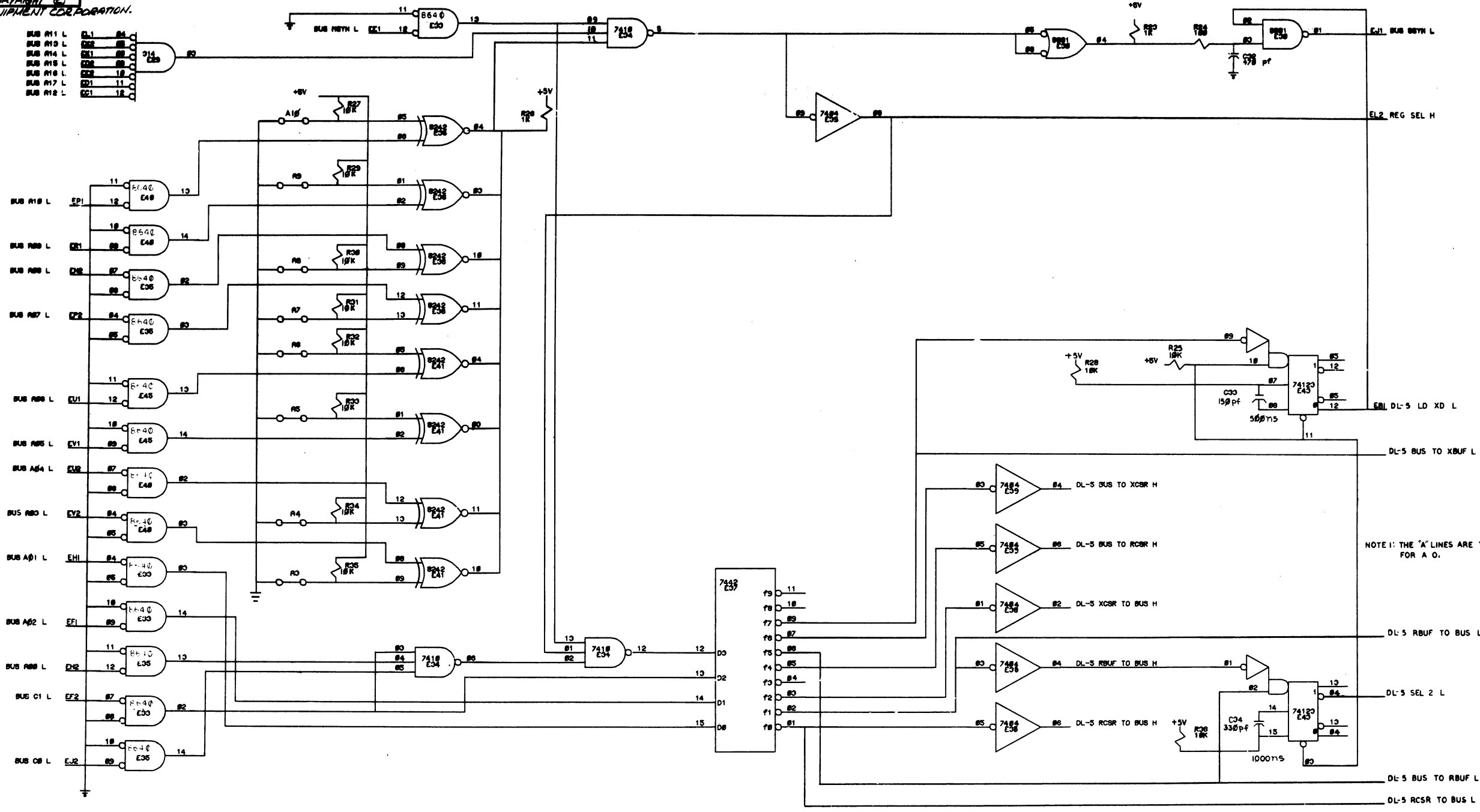

NOTE 1: THE "A" LINES ARE TO BE JUMPED FOR A 0.

REVISIONS		
CHK.	CHANGE NO.	REV.

FIRST USED ON OPTION/MODEL	QTY.	DESCRIPTION	PART NO.	ITEM NO.
DL11				
PARTS LIST				
UNLESS OTHERWISE SPECIFIED: DIMS. IN INCHES. TOLERANCES: DECIMALS: .005 ANGLES: ±0° 30'				
REMOVE BURRS AND BREAK SHARP CORNERS SURFACE QUALITY: <input checked="" type="checkbox"/> BROOM FINISH				
MATERIAL: <input checked="" type="checkbox"/> NEXT HIGHER ASSY.				
FINISH: <input checked="" type="checkbox"/> SCALE: 1:1 SHEET 5 OF 6				
<b>DIGITAL EQUIPMENT CORPORATION</b> <b>ASYNCHRONOUS LINE INTERFACE (ADDRESS SELECTION) DL-5</b>				
MATERIAL: <input checked="" type="checkbox"/> NEXT HIGHER ASSY. FINISH: <input checked="" type="checkbox"/> SCALE: 1:1 SHEET 5 OF 6 DCS M7800-1A-1				

THE INFORMATION CONTAINED HEREIN IS UNCLASSIFIED  
 DATE 11-19-2008 BY 60322 UCBAW/SJS  
 ORIGINAL SOURCE: DIGITAL EQUIPMENT CORPORATION

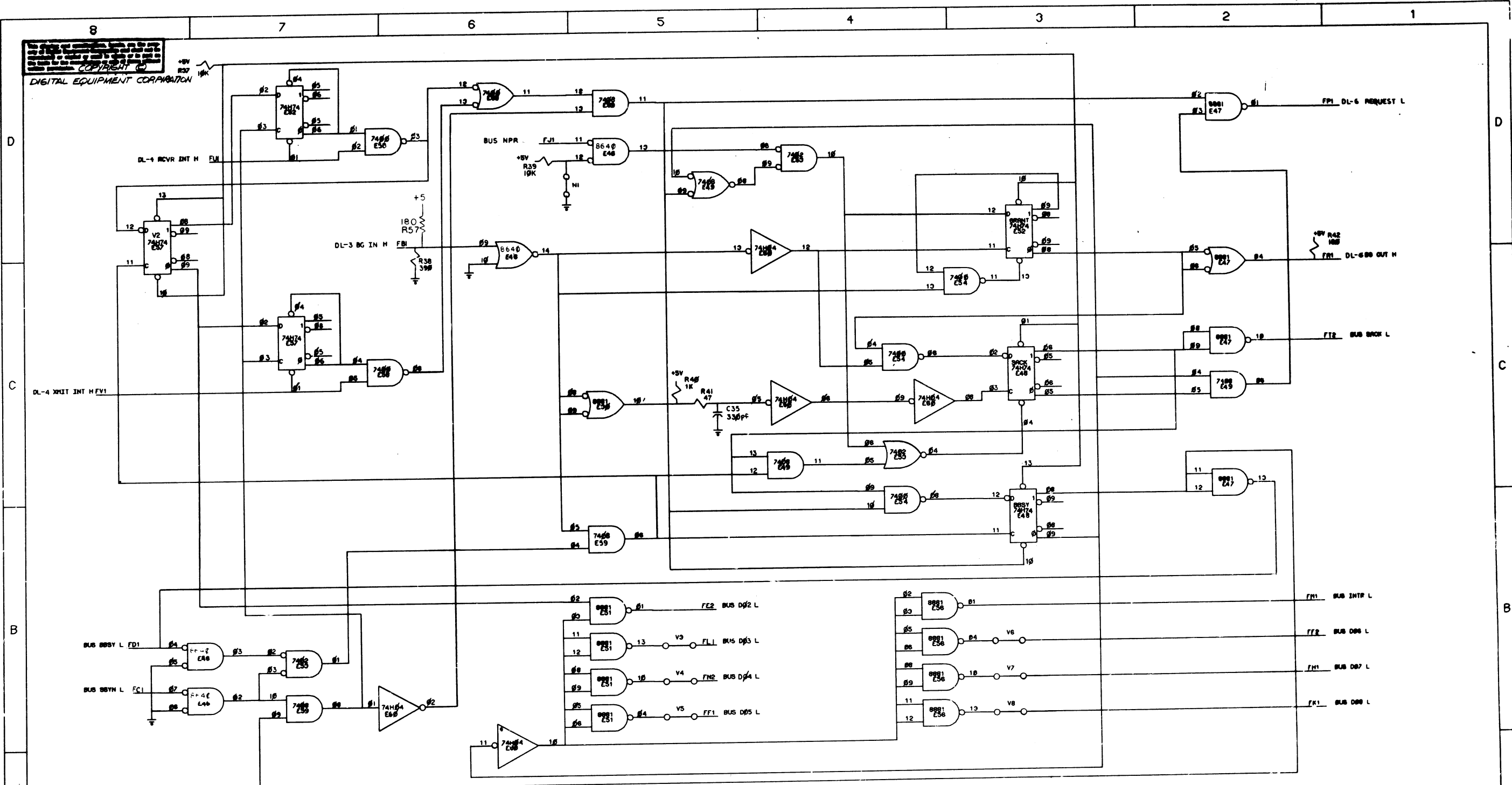

NOTE: THE 'V' LINES ARE TO BE JUMPED FOR A.I.

REVISIONS		
CHK.	CHANGE NO.	REV.

FIRST USED ON OPTION/MODEL	QTY.	DESCRIPTION	PART NO.
DL11			
UNLESS OTHERWISE SPECIFIED DIMENSIONS IN INCHES TOLERANCES	DATE	DATE	DATE
DECIMALS	ANGLES	DATE	DATE
.XX - .005	± 0° 30'	DATE	DATE
.X - .01		DATE	DATE
REMOVE BURRS AND SHARP CORNERS SURFACE QUALITY	PROD.	DATE	DATE
MATERIAL	NEXT HIGHER ASSY.	BY CODE	NUMBER
FINISH	SCALE	DIST.	REV.

**DIGITAL EQUIPMENT CORPORATION**  
 TITLE: **ASYNCHRONOUS LINE INTERFACE (INTERRUPT CONTROL) DL-6**  
 DCS M7800-YA-1  
 SHEET OF

This drawing and specifications, herein, are the property of Digital Equipment Corporation and shall not be reproduced or copied or used in whole or in part as the basis for the manufacture or sale of items without written permission.

WIRE TABLE				
ITEM NO.	DESCRIPTION	PAIR NO.	FROM CONNECTION WITH	TO CONNECTION WITH
3	22 BLK	1	P1-2	P2-KK 5
3	RED	1	P1-3	P2-S
3,7	SHIELD	1	SEE NOTE #2	P2-A(NOTE #2)
3	BLK	2	P1-4	P2-EE
3	WHT	2	P1-5	P2-RR
3,7	SHIELD	2	SEE NOTE #2	P2-A(NOTE #2)
3	BLK	3	P1-6	P2-PP
3	GRN	3	P1-7	P2-K
3,7	SHIELD	3	SEE NOTE #2	P2-A(NOTE #2)
6	22 BLK	1	P2-E	P2-H 8

LEGEND		
VARIATION	LENGTH	
	X	Y
7008360-0	25IN±1.0	27IN±1.0
7008360-1	46IN±1.0	48IN±1.0
7008360-9	9FT±2IN	9FT2IN±2IN

- NOTES:**
- \* ASTERISKS INDICATE CAVITIES NOT USED OR DESIGNATED BY LETTERS.
  - DRAIN WIRES TO BE CUT BACK TO OUTER INSULATION ON P1 END OF CABLE ONLY. SHIELDS TO BE CUT BACK TO OUTER INSULATION ON BOTH ENDS OF CABLES.
  - DRAIN WIRES ON P2 END OF CABLE TO BE EACH ENCLOSED WITH ITEM #7 (TUBING) FROM END OF CABLE JACKET TO POINT WHERE THEY ENTER P2 CONNECTOR.
  - ITEM #6 (WIRE) TO BE APPROXIMATELY ONE (1) INCH LONG.
  - PLACE ITEM #9 ("THIS SIDE UP" STICKER) ON LETTERED SIDE OF ITEM #4 (BERG HOUSING) AS SHOWN.

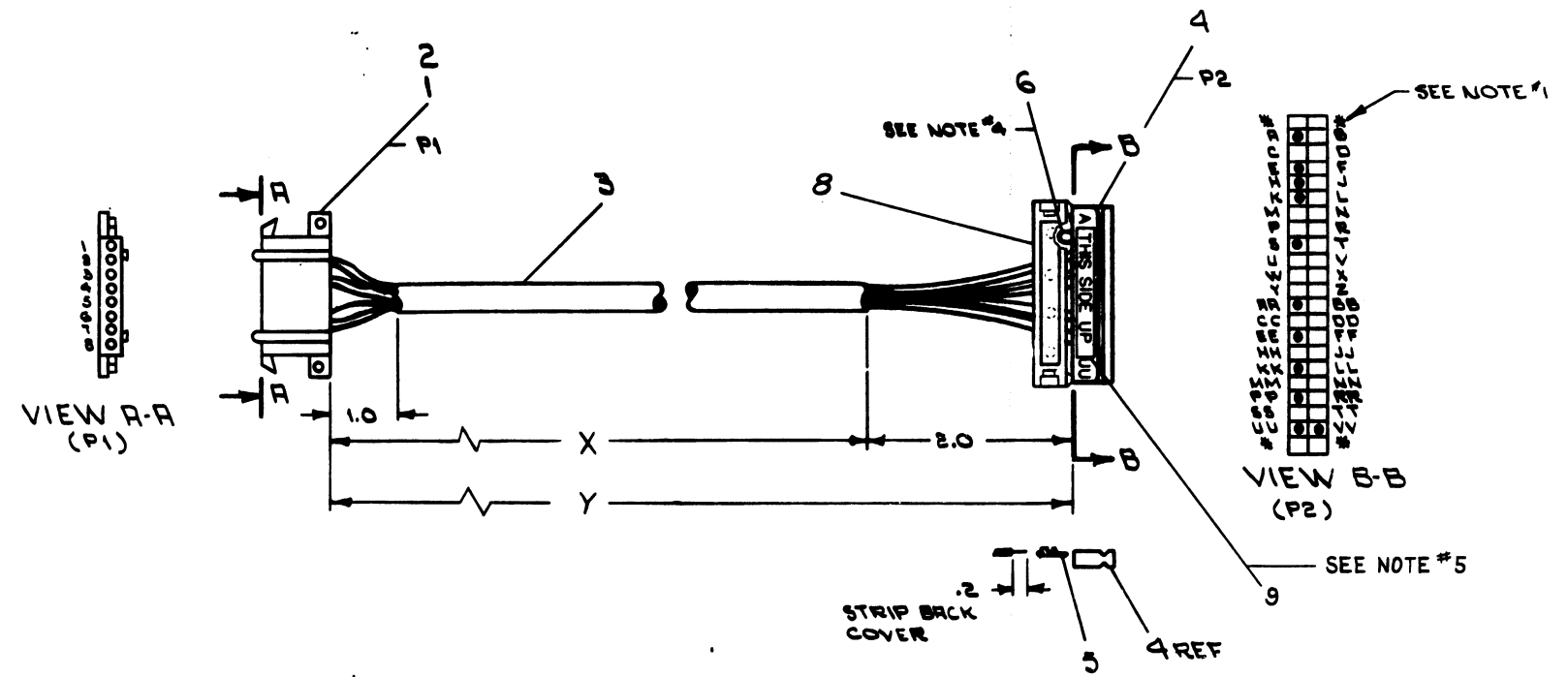

QTY.	DESCRIPTION	PART NO.	ITEM NO.
1	LABEL, THIS SIDE UP	3611567	9
1	STRAIN RELIEF	1211166	8
	AIR TUB. #18 STEF. THINWALL NAT	910270-11	7
	AIR WIRE #22 AWG STRD TEF BLK	9107350-00	6
11	SOCKET, CRIMP #4 7216	1810089-07	5
1	HOUSING, BERG #650 23-015	1210913-15	4
	AIR CABLE, BELDEN #8177-3PR SHLD	9107723-0	3
6	CONTACT MATE-N-LOCK (FEMALE)	1209379-03	2
1	CONN. MATE-N-LOCK (FEMALE)	1209340-00	1

REV.	CHANGE NO.	REV.
A	1	KLBE-00002
B	2	KLBE-00005
C	3	7008360-00001
D	4	7008360-00002
E	5	7008360-00003
F	6	7008360-00004
G	7	7008360-00004
H	8	7008360-00004

FIRST USED ON OPTION/MODEL PDP-8E	DO NOT SCALE DRAWING UNLESS OTHERWISE SPECIFIED DIMENSION IN INCHES TOLERANCES ANGLES FINAL SURFACE QUALITY REMOVE BURRS AND BREAK SHARP CORNERS	DRN: [Signature] DATE: [Date] CHK'D: [Signature] DATE: [Date] ENG: [Signature] DATE: [Date] PROJ. ENG: [Signature] DATE: [Date] PROD: [Signature] DATE: [Date]	<b>digital EQUIPMENT CORPORATION</b> MAYNARD, MASSACHUSETTS <b>CABLE ASSEMBLY (KL8E)</b> SIZE CODE: DIA7008360-0-0 NUMBER: H REV: H
--------------------------------------	--	--	--

H  
 C  
 B  
 A  
 7008360-0-0  
 H  
 1  
 2  
 3  
 4  
 5  
 6  
 7  
 8

**DIGITAL EQUIPMENT CORPORATION**  
MAYNARD, MASSACHUSETTS

**SOFTWARE LIST**

**LEGEND**

- D DOCUMENT
- DN DOCUMENT CHANGE NOTICE
- PA PAPER TAPE ASCII
- PB PAPER TAPE BINARY
- PM PAPER TAPE READ-IN-MODE

**QUANTITY / VARIATION**

MADE BY <u>EMPellegrini</u>	CHECKED <u>P. Janson</u>	SECTION
DATE <u>8/29/72</u>	DATE <u>8-30-72</u>	
ENG <u>P. Janson</u>	PROD <u>J. McHugh</u>	ISSUED SECT.
DATE <u>8/29/72</u>	DATE <u>8-31-72</u>	

ITEM NO.	DWG NO. / PART NO.	DESCRIPTION	DL11-A	DL11-B	DL11-C	DL11-D	DL11-E	KIT CHECK	BY	DATE	INSTALLATION CHECK	BY	DATE
1	LIBKIT-11-KL11-04	KL11 MAINDEC	1	1	0	0	0						
2	LIBKIT-11-DL11C-A-K	DL11 MAINDEC	0	0	1	1	0						
3	LIBKIT-11-DL11E-A-K	DL11 MAINDEC	0	0	0	0	1						

TITLE DL11 SOFTWARE LIST	ASSY. NO.	SIZE CODE <b>A SL</b>	NUMBER DL11-0-4	REV.	ECO NO.
	SHEET 1 OF 1	DIST.			

DIGITAL EQUIPMENT CORPORATION MAYNARD, MASSACHUSETTS				LEGEND		QUANTITY / VARIATION											
ACCESSORY LIST			D DOCUMENT DN DOCUMENT CHANGE NOTICE PA PAPER TAPE ASCII PB PAPER TAPE BINARY PM PAPER TAPE READ-IN-MODE		DL11-A	DL11-B	DL11-C	DL11-D	DL11-E			KIT CHECK	BY	DATE	INSTALLATION CHECK	BY	DATE
MADE BY	E. Pellegrini	CHECKED	<i>P. Janson</i>	SECTION													
DATE	June 26, 1972	DATE	8-8-72														
ENG	Paul Janson	PROD	<i>J. H. H. H.</i>	ISSUED SECT.													
DATE	June 26, 1972	DATE	8-8-72														
ITEM NO.	DWG NO. / PART NO.	DESCRIPTION			DL11-A	DL11-B	DL11-C	DL11-D	DL11-E								
1	M7800	ASYNCHRONOUS LINE INTERFACE (EIA)			1	1	1	1	1								
2	G8000	FILTER NETWORK			0	A/R	0	A/R	0								
3	M7800-YA	ASYNCHRONOUS LINE INTERFACE (CURRENT LOOP)			1	0	1	0	0								
4	5408776	PRIORITY JUMPER LEVEL #4			1	1	1	1	1								
5	BC05-C-25	MODEM CABLE			0	1	0	1	1								
6	7008360	TTY CABLE			1	0	1	0	0								
7	-	CRYSTAL			1	1	1	1	1								
8	-	DL11 ENGINEERING DRAWINGS			1	1	1	1	1								
9	DEC-11-HDLAA-A-D	DL11 ASYNCHRONOUS LINE INTERFACE MANUAL			1	1	1	1	1								
10	LIBKIT-11-KL11-04	KL11 MAINDEC			1	1	0	0	0								
11	LIBKIT-11-DL11C-A-K	DL11 MAINDEC			0	0	1	1	0								
12	LIBKIT-11-DL11E-A-K	DL11 MAINDEC			0	0	0	0	1								
13	H315	MODEM TEST CONNECTOR			0	0	0	0	A/R								
NOTES: 1. G8000 IS REQUIRED ONLY IN PDP-11 SYSTEMS WHERE +15V IS NOT AVAILABLE. ONE PER DD11-A.																	
2. CRYSTAL FREQUENCY DEFINED BY CUSTOMER SPECIFIED BAUD RATE.																	
3. ONE H315 PER PDPII SYSTEM																	
4. INSURE THAT TRANSPARENT VINYL TAPE HAS BEEN APPLIED TO THE TOP SURFACE OF THE CRYSTAL AND MOUNTING BRACKET.																	
TITLE				ASSY. NO.	SIZE	CODE	NUMBER			REV.	ECO NO						
DL11 CHECK LIST					A	AL	DL11-0-5			C	DL11-00005						
				SHEET 1 OF 1	DIST.												

DIGITAL EQUIPMENT CORPORATION MAYNARD, MASSACHUSETTS					
TITLE DL11 INSTALLATION PROCEDURE					DATE 6-21-72
REVISIONS					
REV	DESCRIPTION	CHG NO	ORIG	DATE	APPD BY
C	CHANGE PER ECO	DL11-4	JANSON	3/73	<i>P. Dumas</i>
D	CHANGE PER ECO	DL11-5	CONDON	7/73	<i>P. G. Day</i>
E	CHANGE PER ECO	DL11-7	CONDON	8/74	<i>P. G. Day</i>
F	CHANGE PER ECO	DL11-8	CONDON	4-75	<i>P. G. Day</i>

ENG	APP'D	SIZE	CODE	NUMBER	REV
J. E. ...	<i>J. E. ...</i>	A	SP	DL11-0-2	F

DEC FORM NO. DRA 108  
SHEET 1 OF 9

ENGINEERING SPECIFICATION		CONTINUATION SHEET	
TITLE DL11 INSTALLATION PROCEDURE			
DL11 INSTALLATION PROCEDURE:			
Installation of the M7800 module or its variation as a DL11-A through DL11-E option consists of the following preparations:			
<ol style="list-style-type: none"> <li>Jumper insertion/deletion for selection of operation mode (A, B, C, D, or E).</li> <li>Register address assignment.</li> <li>Vector address assignment.</li> <li>Priority assignment.</li> <li>Special NPR jumper insertion/deletion.</li> <li>Selection of data format (data bits, stop bits, parity).</li> <li>Selection of crystal for baud rate.</li> <li>Installation of G8000 in systems where +15v is not available.</li> <li>Filter capacitor selection for high baud rate current-loop.</li> </ol>			
A. OPERATION MODE:			
The following describes the jumpers associated with controlling the mode of operation (A, B, C, D, or E):			
J1.	Ties EIA driver to REQUEST-TO-SEND lead (pin 4) of dataset cable. IN for DL11-B, D, and E; does not affect DL11-A and C. Drawing DL-7.		
J2.	Ties EIA driver, normally used for the REQUEST-TO-SEND lead, to FORCE BUSY lead (pin 25) for use with Bell 103E. This is a customer option. If not specified, jumper is OUT for all DL11's. Drawing DL-7.		
J3.	When inserted, allows REQUEST-TO-SEND lead (pin 4) to be controlled by bit 2 of the receiver status register. OUT for DL11-B and D; IN for DL11-E; does not affect DL11-A and C. Drawing DL-4.		
J4.	When inserted, forces "DATA LEADS ONLY" mode of EIA operation. Turns DATA TERMINAL READY (pin 20) and REQUEST-TO-SEND (pin 4) on. IN for DL11-B and D; OUT for DL11-E; does not affect DL11-A and C. Drawing DL-4.		
J5.	When inserted, allows the BREAK bit to function. OUT for DL11-A and B; IN for DL11-C, D, and E. Drawing DL-4.		
J6.	When inserted, allows DSET INT to cause interrupts. OUT for DL11-A, B, C and D; IN for DL11-E. Drawing DL-4.		
J7.	When inserted, allows dataset control bits to be read as part of the receiver status register.		

DEC FORM NO. DRA 108  
SHEET 2 OF 9

ENGINEERING SPECIFICATION		CONTINUATION SHEET	
TITLE DL11 INSTALLATION PROCEDURE			
C. VECTOR ADDRESS ASSIGNMENT:			
Jumpers V8 through V3 control the interrupt vector. A jumper inserted provides a vector bit of one. Vectors can be produced in the form XX# where XX ranges from #0 to 77.			
For the DL11-A and B used as a console device the vector address is 060/064. For additional units vectors are floating.			
For the DL11-C, D, and E vector addresses are floating. Assign all C's first, then D's then E's.			
D. PRIORITY ASSIGNMENT:			
Interrupt priority is established by inserting a "priority plug" in the socket at IC location E19. For DL11-A, B, C, D and E use level 4, for the standard assignment or level 5-7 as specified by the customer or the documentation of an option which uses the DL11.			
SUMMARY OF REGISTER, VECTOR AND PRIORITY ASSIGNMENTS:			
	ADDRESS	VECTOR	PRIORITY
DL11-A, B CONSOLE	777560 777562 777564 777566	60/64	BR4
DL11-A, B ADDITIONAL UNITS	776XX# 776XX2 776XX4 776XX6	FLOATING	BR4
Where XX= 50 for line #1 and XX= 67 for line #16			
	ADDRESS	VECTOR	PRIORITY
DL11-C, D, E	77XXX# 77XXX2 77XXX4 77XXX6	Floating	4
Where XXX= 561 for line #1 and XXX= 617 for line #31			

DEC FORM NO. DRA 108  
SHEET 4 OF 9

ENGINEERING SPECIFICATION		CONTINUATION SHEET	
TITLE DL11 INSTALLATION PROCEDURE			
C. VECTOR ADDRESS ASSIGNMENT:			
Jumpers V8 through V3 control the interrupt vector. A jumper inserted provides a vector bit of one. Vectors can be produced in the form XX# where XX ranges from #0 to 77.			
For the DL11-A and B used as a console device the vector address is 060/064. For additional units vectors are floating.			
For the DL11-C, D, and E vector addresses are floating. Assign all C's first, then D's then E's.			
D. PRIORITY ASSIGNMENT:			
Interrupt priority is established by inserting a "priority plug" in the socket at IC location E19. For DL11-A, B, C, D and E use level 4, for the standard assignment or level 5-7 as specified by the customer or the documentation of an option which uses the DL11.			
SUMMARY OF REGISTER, VECTOR AND PRIORITY ASSIGNMENTS:			
	ADDRESS	VECTOR	PRIORITY
DL11-A, B CONSOLE	777560 777562 777564 777566	60/64	BR4
DL11-A, B ADDITIONAL UNITS	776XX# 776XX2 776XX4 776XX6	FLOATING	BR4
Where XX= 50 for line #1 and XX= 67 for line #16			
	ADDRESS	VECTOR	PRIORITY
DL11-C, D, E	77XXX# 77XXX2 77XXX4 77XXX6	Floating	4
Where XXX= 561 for line #1 and XXX= 617 for line #31			

DEC FORM NO. DRA 108  
SHEET 4 OF 9

This drawing and specifications, herein, are the property of Digital Equipment Corporation and shall not be reproduced or copied or used in whole or in part as the basis for the manufacture or sale of items without written permission.

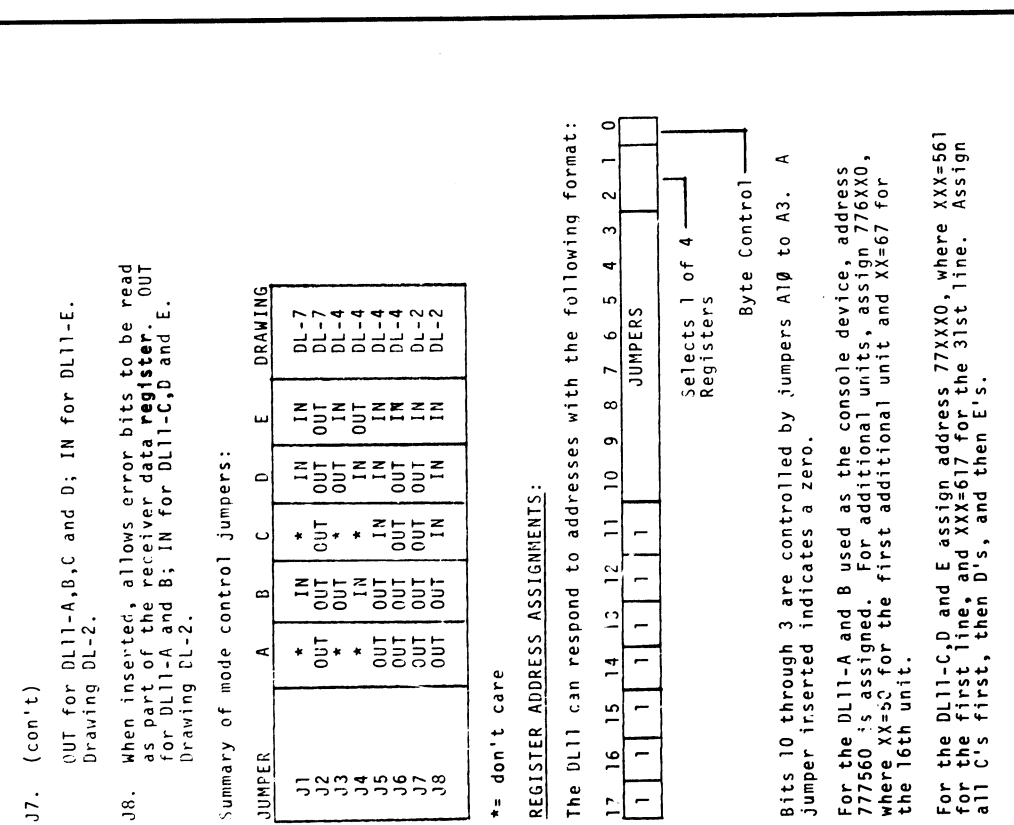

ENG	APP'D	SIZE	CODE	NUMBER	REV
J. E. ...	<i>J. E. ...</i>	A	SP	DL11-0-2	F

DEC FORM NO. DRA 108  
SHEET 3 OF 9

**ENGINEERING SPECIFICATION**

CONTINUATION SHEET

TITLE DL11 INSTALLATION PROCEDURE

**E. SPECIAL NPR JUMPER:**  
 Jumper N1, shown on drawing DL-6, controls the response of the interrupt circuit to an NPR request. The jumper should normally be IN, except for 11/20 and 11/15 systems without the KHL1 option.

**F. SELECTION OF DATA FORMAT:**

1. Data Bits

Split lug pairs NB2 and NB1 control the number of data bits in the serial character as follows:

NB2	NB1	# OF DATA BITS
OUT	OUT	8
OUT	IN	7
IN	OUT	6
IN	IN	5

2. Parity

Parity is controlled by split lug pairs NP and EPS as follows:

NP	EPS	PARITY
OUT	OUT	OFF
OUT	IN	OFF
IN	OUT	EVEN
IN	IN	ODD

3. Stop Bits

Split lug pair 2S8 and jumpers J9, J10 and J11 control the number of stop bits in the serial character as follows:

2S8	J9	J10	J11	# OF STOP BITS
OUT	OUT	IN	OUT	2
IN	OUT	IN	OUT	1
IN	OUT	OUT	IN	1.5 for TI, GI, and SCH UAR1TS
IN	IN	OUT	OUT	1.5 for MD UAR1TS

**G. CRYSTAL SELECTION:**

The clocking scheme of the DL11 consists of a single crystal oscillator feeding a divider network, with two 10-position switches tapping various points to feed into the UAR1T's

SIZE	CODE	NUMBER	REV
A	SP	DL11-0-2	F

DSC FORM NO DEC 16-(1981)-1022-N370  
 DSA 106

SHEET 5 OF 9

**ENGINEERING SPECIFICATION**

CONTINUATION SHEET

TITLE DL11 INSTALLATION PROCEDURE

**H. G8000 INSTALLATION:**

For DL11-B, D, and E a positive voltage is required between 9 and 15 volts to operate the EIA drivers. For PDP-11/20 and PDP-11/15 systems with the H720 power supply, a G8000 module must be installed to provide this voltage. Using a filter network, this module converts the full-wave rectified +48V signal to a positive DC voltage.

1. Install G8000 into slot A02 of DD11-A.
  2. Wire A03V2 to A02Y2.
  3. Wire A02N2 to CXU1 where XX is the slot location of the M7800.
- Refer to diagram 1.

**I. FILTER CAPACITOR SELECTION:**

For DL11-A's and DL11-C's, which operate with 20ma current loops, capacitors are used to filter the receive line and slow the switching time of the transmit line. To avoid excessive distortion above 150 baud, the capacitance in each of these two circuits must be reduced. This is accomplished by clipping C29 (.47 mfd) and C31 (1000 pf), both shown on drawing DL-3.

**J. DL11-B,D,E in Systems with +15V available using DD11-A:**  
 There is a special situation of using a DD11-A to mount a DL11-B, D, or E in systems with +15V available. These systems have +15V available and it appears at pin A03V2 of the DD11-A when using power harness such as 7009177, 7008855, or 7008909. In this situation, no G8000 is necessary, and +15V can be wired directly from A03V2 to CXU1, where XX is the slot number of the DL11.  
 NOTE: this does not apply to DL11-A or C or DD11-B.

**K. When using the DL11-B,D,E in an 11/05 processor pin CXU1 has +15V available on it so no G8000 or no jumpers are required.**

SIZE	CODE	NUMBER	REV
A	SP	DL11-0-2	F

DSC FORM NO DEC 16-(1981)-1022-N370  
 DSA 106

SHEET 7 OF 9

**ENGINEERING SPECIFICATION**

CONTINUATION SHEET

TITLE DL11 INSTALLATION PROCEDURE

**6. Cont**  
 transmitter and receiver sections. Thus, for a given crystal frequency, 8 baud rates are independently selectable for transmit and receive. The two additional switch positions select external clocks.

POSITION	FACTOR	CRYSTAL (MHZ)			
		1	2	3	4
1*	23040	36.7	44.8	50	50
2	15360	55	67.3	75	300
3	7680	110	134.5	150	600
4	3840	220	269	300	1200
5	1920	440	538	600	2400
6	960	880	1076	1200	4800
7	640	1320	1614	1800	7200
8	480	1760	2152	2400	9600

\*Most counter-clock wise position.

To determine a crystal frequency for a non-standard baud rate, pick the position of the closest baud rate in the 1.152MHz column, and then multiply the non-standard baud rate by the factor for that position. For example, if the customer specifies 1050 baud, this is closest to 1200 baud, position 6.

1050 X 960 = 1008000 = 1.008MHZ.

The crystal frequency should not fall outside the range of the standard DLI1 crystals. Although the above table includes only the standard DLI1 crystals other values may be specified by the customer or by other documentation of an option which uses the DL11.

DBC part number for the standard crystals are as follows:

844.8 KHZ	18-10245-1*
1.03296 MHZ	18-05501-6
1.152 MHZ	18-05501-5
4.608 MHZ	18-05501-7

\*Use A or C cut crystals only. Do not use crystals marked NE-6D. When ordering a special crystal, refer to purchase specification 18-05501 for crystal specification.

Insure that transparent vinyl tape (9008269) is applied to the top surfaces of the crystal and mounting brackets to insulate from adjacent modules.

SIZE	CODE	NUMBER	REV
A	SP	DL11-0-2	F

DSC FORM NO DEC 16-(1981)-1022-N370  
 DSA 106

SHEET 6 OF 9

**ENGINEERING SPECIFICATION**

CONTINUATION SHEET

TITLE DL11 INSTALLATION PROCEDURE

DIAGRAM 1. G8000 INSTALLATION

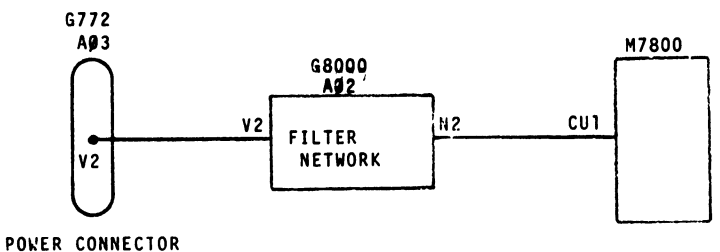

SIZE	CODE	NUMBER	REV
A	SP	DL11-0-2	F

DSC FORM NO DEC 16-(1981)-1022-N370  
 DSA 106

SHEET 8 OF 9

TITLE DL11 INSTALLATION PROCEDURE

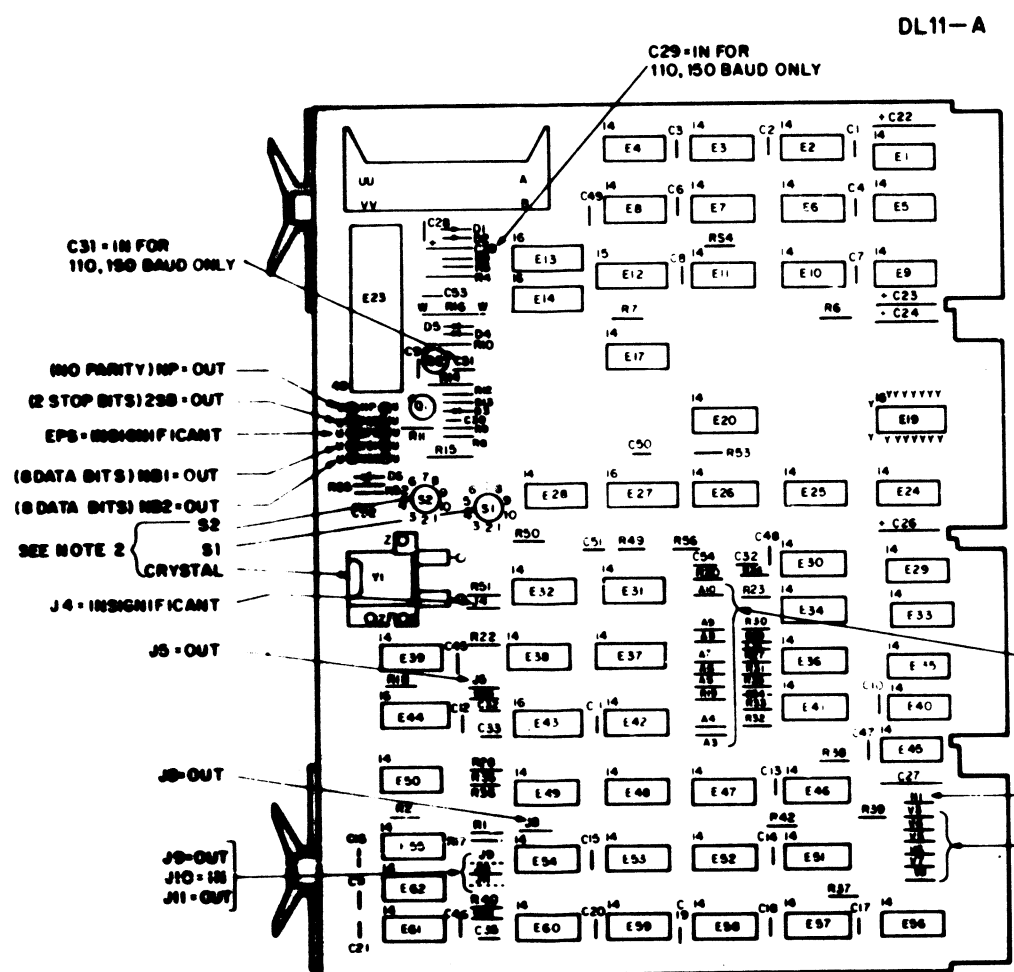

DL11-A

NOTES:

- For further information on the DL11-A configuration or the installation of DL11-B, DL11-C, DL11-D or DL11-E refer to:
  - DL11 Asynchronous Line Interface Manual
  - ASP-DL11-0-2 (DL11 installation procedure) in the DL11 Engineering Drawings.

SPEED GROUP	BAUD RATE			
	1	2	3	4
CRYSTAL FREQ (HZ)	844.8K	1.03296M	1.152M	1.608M
S1, S2 POS.				
1	36.7	44.8	50	200
2	55	67.3	75	300
3	110	134.5	150	600
4	220	269	300	1200
5	440	538	600	2400
6	880	1076	1200	4800
7	1320	1614	1800	7200
8	1760	2152	2400	9600

Position 1 is most counter-clockwise position

ADDRESS

N1 (EXCEPT FOR 11/20 & 11/15 SYSTEMS WITHOUT KH1 OPTION)

VECTOR ADDRESS

11-2454

REV F

NUMBER DL11-0-2

SIZE CODE SP A

SHEET 9 OF 9





CUSTOMER PRINT SET				FIND NO.	DRAWING NO.	REV	NO OF SHT	DESCRIPTION	OPTION NO.	CUSTOMER PRINT SET						
										FIND NO.	DRAWING NO.	REV	NO OF SHT	DESCRIPTION	OPTION NO.	
X				X	D-TD-KW11-L-02	*	1	TIMING DIAGRAM, KW11-L								
X				X	D-BS-KW11-L-01	A	2	LINE FREQUENCY INTERNAL CLOCK								
				X	A-SP-KW11-L-03	*	3	TEST PROCEDURE								
X				X	D-CS-M787-0-1	#	2	LINE CLOCK								
X				X	A-PL-KW11-L-0	*	1	LINE FREQUENCY CLOCK								
X				X	A SL KW11 L 28	*	1	SOFTWARE LIST								
				TITLE					LINE FREQUENCY CLOCK (KW11-L)		SHEET 2 OF 2		SIZE CODE	NUMBER		REV
											B DD		KW11-L-0		*	

# DRAWING DIRECTORY

"THIS DRAWING AND SPECIFICATIONS, HERETH, ARE THE PROPERTY OF DIGITAL EQUIPMENT CORPORATION AND SHALL NOT BE REPRODUCED OR COPIED OR USED IN WHOLE OR IN PART AS THE BASIS FOR THE MANUFACTURE OR SALE OF ITEMS WITHOUT WRITTEN PERMISSION. COPYRIGHT © , DIGITAL EQUIPMENT CORPORATION"

## CUSTOMER PRINT SET INDEX

THIS IS PRINT SET

SEQUENCE		SEQUENCE
RESTART LOADER (PL)		A-PL-BM873-ø
RESTART LOADER		D-CS-M873-ø-1
WORD LISTING OF ROM CONTENTS (FOR M873-YA)		B-AP-M873-ø-9
WORD LISTING OF ROM CONTENTS (FOR M873-YB)		B-AP-M873-ø-14
WORD LISTING OF ROM CONTENTS (FOR M873-YC)		B-CS-M873-ø-17
WORD LISTING OF ROM CONTENTS (FOR M873-YD)		B-CS-M873-ø-22
WORD LISTING OF ROM CONTENTS (FOR M873-YF)		B-CS-M873-ø-27
WORD LISTING OF ROM CONTENTS (FOR M873-WA)		K-CS-M873-0-32
WORD LISTING OF ROM CONTENTS (FOR M873-YG)		B-CS-M873-ø-33
WORD LISTING OF ROM CONTENTS (FOR M873-YH)		B-CS-M873-ø-34

UNIT VARIATIONS		PRINT SET			
VAR	TITLE				
M873-ø	RESTART LOADER	1			
BM873-YA	RESTART LOADER	1			
BM873-YB	RESTART LOADER	1			
BM873-YC	RESTART LOADER	1			
BM873-YD	RESTART LOADER	1			
BM873-YF	RESTART LOADER	1			
BM873-WA	RESTART LOADER DN80 SERIES	1			
BM873-YG	RESTART LOADER	1			
BM873-YH	RESTART LOADER	1			

DEC 16-1983-1062-1A-R872

<b>REVISIONS</b> <table border="1"> <thead> <tr> <th>DATE</th> <th>CHG. NO.</th> <th>REV</th> </tr> </thead> <tbody> <tr> <td>10/75</td> <td>BM873-4</td> <td>D</td> </tr> <tr> <td>10/75</td> <td>BM873-5</td> <td>E</td> </tr> <tr> <td>9/76</td> <td>BM873-6</td> <td>F</td> </tr> </tbody> </table>	DATE	CHG. NO.	REV	10/75	BM873-4	D	10/75	BM873-5	E	9/76	BM873-6	F	<table border="1"> <thead> <tr> <th>USED ON OPTION/MODEL</th> <th>DRN.</th> <th>DATE</th> <th>TITLE</th> </tr> </thead> <tbody> <tr> <td></td> <td>K. GLEEZEN</td> <td>11/73</td> <td rowspan="6">RESTART LOADER</td> </tr> <tr> <td></td> <td>CHK'D.</td> <td>DATE</td> </tr> <tr> <td></td> <td>K. GLEEZEN</td> <td>11/73</td> </tr> <tr> <td></td> <td>PROJ ENG.</td> <td>DATE</td> </tr> <tr> <td></td> <td>R. DIETER</td> <td>11/73</td> </tr> <tr> <td></td> <td>PROD.</td> <td>DATE</td> </tr> <tr> <td></td> <td>J. BORENSTEIN</td> <td>11/73</td> </tr> <tr> <td></td> <td>FIELD SERV.</td> <td>DATE</td> <td>SIZE CODE</td> <td>NUMBER</td> <td>REV</td> </tr> <tr> <td>SHEET</td> <td>1</td> <td>OF</td> <td>2</td> <td>B</td> <td>DD</td> <td>BM873 ø</td> <td>F</td> </tr> <tr> <td colspan="4"></td> <td>DIST</td> <td></td> <td></td> <td></td> </tr> </tbody> </table>	USED ON OPTION/MODEL	DRN.	DATE	TITLE		K. GLEEZEN	11/73	RESTART LOADER		CHK'D.	DATE		K. GLEEZEN	11/73		PROJ ENG.	DATE		R. DIETER	11/73		PROD.	DATE		J. BORENSTEIN	11/73		FIELD SERV.	DATE	SIZE CODE	NUMBER	REV	SHEET	1	OF	2	B	DD	BM873 ø	F					DIST			
	DATE	CHG. NO.	REV																																																										
	10/75	BM873-4	D																																																										
	10/75	BM873-5	E																																																										
	9/76	BM873-6	F																																																										
	USED ON OPTION/MODEL	DRN.	DATE	TITLE																																																									
	K. GLEEZEN	11/73	RESTART LOADER																																																										
	CHK'D.	DATE																																																											
	K. GLEEZEN	11/73																																																											
	PROJ ENG.	DATE																																																											
	R. DIETER	11/73																																																											
	PROD.	DATE																																																											
	J. BORENSTEIN	11/73																																																											
	FIELD SERV.	DATE	SIZE CODE	NUMBER	REV																																																								
SHEET	1	OF	2	B	DD	BM873 ø	F																																																						
				DIST																																																									

CUSTOMER PRINT SET						CUSTOMER PRINT SET								
	MFG. SET	FIND NO.	DRAWING NO.	REV	NO OF SHT	OPTION NO./FILE DATE		MFG. SET	FIND NO.	DRAWING NO.	REV	NO OF SHT	DESCRIPTION	OPTION NO./FILE DATE
X		1	A-PL-BM873-0-0	A	1	RESTART LOADER (PL)		X	7	K-CS-M873-0-28	9	9	ROM LISTING (FOR 23225A2)	
	X		A-SP-BM873-0-1		16	BM873 ENG. SPECIFICATION		X		K-CS-M873-0-29	9	9	ROM LISTING (FOR 23226A2)	
	X		A-SP-BM873-0-2		1	BM873 TEST PROCEDURE		X		K-CS-M873-0-30	9	9	ROM LISTING (FOR 23227A2)	
X			A-AL-BM873-0-3		1	BM873 ACCESSORY LIST		X		K-CS-M873-0-31	9	9	ROM LISTING (FOR 23228A2)	
							X	X		K-CS-M873-0-32	1	1	WORD LISTING OF ROM CONTENTS (FOR BM873-WA)	
X	X	2	D-CS-M873-0-1	#	4	RESTART LOADER		X	8	A-PS-23338A2-0-0	3	3	ROM LISTING (FOR 23338A2)	
			K-CO-M873-0-4		1	X-Y COORDINATE HOLE LOCATION		X		A-PS-23339A2-0-0	3	3	ROM LISTING (FOR 23339A2)	
			D-AH-M873-0-5		1	ASSY/DRILLING HOLE LAYOUT		X		A-PS-23340A2-0-0	3	3	ROM LISTING (FOR 23340A2)	
	X		B-MH-M873-0-6		1	MODULE ECO HISTORY		X		A-PS-23341A2-0-0	3	3	ROM LISTING (FOR 23341A2)	
	X		K-RL-M873-0-7	#	9	ROM LISTING (FOR 23044A2)		X		B-CS-M873-0-33	1	1	WORD LISTING OF ROM CONTENTS (FOR BM873-YG)	
	X		K-RL-M873-0-8	#	9	ROM LISTING (FOR 23045A2)	X	X						
X	X		B-AP-M873-0-9	#	1	WORD LISTING OF ROM CONTENTS (FOR M873-YA)			9	A-PS-23327A2-0-0	3	3	ROM LISTING (FOR 23327A2)	
	X		K-RL-M873-0-10		9	ROM LISTING (FOR 23089A2)		X		A-PS-23328A2-0-0	3	3	ROM LISTING (FOR 23328A2)	
	X		K-RL-M873-0-11		9	ROM LISTING (FOR 23090A2)		X		A-PS-23329A2-0-0	3	3	ROM LISTING (FOR 23329A2)	
	X		K-RL-M873-0-12		9	ROM LISTING (FOR 23091A2)		X		A-PS-23330A2-0-0	3	3	ROM LISTING (FOR 23330A2)	
	X		K-RL-M873-0-13		9	ROM LISTING (FOR 23092A2)	X	X		B-CS-M873-0-34	1	1	WORD LISTING OF ROM CONTENTS (FOR BM873-YH)	
X	X		B-AP-M873-0-14		1	WORD LISTING OF ROM CONTENTS (FOR M873-YB)								
	X	4	K-RL-M873-0-7		9	ROM LISTING (FOR 23044A2)								
	X		K-RL-M873-0-8		9	ROM LISTING (FOR 23045A2)								
	X		K-CS-M873-0-15		9	ROM LISTING (FOR 23109A2)								
	X		K-CS-M873-0-16		9	ROM LISTING (FOR 23110A2)								
X	X		B-CS-M873-0-17		1	WORD LISTING OF ROM CONTENTS (FOR M873YC)								
	X	5	K-CS-M873-0-18		9	ROM LISTING (FOR 23095A2)								
	X		K-CS-M873-0-19		9	ROM LISTING (FOR 23096A2)								
	X		K-CS-M873-0-20		9	ROM LISTING (FOR 23097A2)								
	X		K-CS-M873-0-21		9	ROM LISTING (FOR 23098A2)								
X	X		B-CS-M873-0-22		1	WORD LISTING OF ROM CONTENTS (FOR M873 YD)								
	X	6	K-CS-M873-0-23		9	ROM LISTING (FOR 23215A2)								
	X		K-CS-M873-0-24		9	ROM LISTING (FOR 23216A2)								
	X		K-CS-M873-0-25		9	ROM LISTING (FOR 23217A2)								
	X		K-CS-M873-0-26		9	ROM LISTING (FOR 23218A2)								
	X		B-CS-M873-0-27		1	WORD LISTING OF ROM CONTENTS (FOR M873-YF)								

CUSTOMER PRINT SET CODES	X = PRINT OF DOCUMENT INCLUDED IN PRINT SET C = INCLUDES ALL PRINTS INDICATED ON DOCUMENT S = CONFIDENTIAL AUTHORIZED SIGNATURE REQUIRED	TITLE	RESTART LOADER	SIZE	CODE	NUMBER	REV
				SHEET 2	OF 2	B DD BM873-0	F

# DRAWING DIRECTORY

THIS IS PRINT SET 

--	--	--	--	--

## CUSTOMER PRINT SET INDEX

<p>SEQUENCE DRAWING DIRECTORY BLOCK DIAGRAM SYSTEM ADDRESS PATHS SYSTEM STATUS REGISTER ACCESSORY LIST</p>	<p>(SHEETS 1+2 ONLY)</p> <p>B-DD-KT11-C D-BD-KT11-C-1 E-CS-MB17-1 E-CS-MB18-1 A-AL-KT11-C-2</p>
--	---

UNIT VARIATIONS		PRINT SET TYPE			
VARIATION	TITLE	KT11-C-1			
KT11-C	MEMORY MANAGEMENT UNIT (FOR KB11-A)	X			
KT11-CD	MEMORY MANAGEMENT UNIT (FOR KB11-D)	X			

NOTE: 1. USE KT11-C ONLY WITH KB11-A & FPII-B  
2. USE KT11-CD ONLY WITH KB11-D & FPII-C

<p>REVISIONS</p> <table border="1" style="display: inline-table;"> <thead> <tr><th>DATE</th><th>CHG. NO.</th><th>REV</th></tr> </thead> <tbody> <tr><td>RG</td><td>KT11-C-1</td><td>A</td></tr> <tr><td>12/75</td><td>KT11-C-2</td><td>B</td></tr> </tbody> </table>		DATE	CHG. NO.	REV	RG	KT11-C-1	A	12/75	KT11-C-2	B	<p>USED ON OPTION/MODEL</p> <table border="1" style="display: inline-table;"> <tbody> <tr><td>11/45</td><td> </td></tr> <tr><td>11/50</td><td> </td></tr> <tr><td>11/55</td><td> </td></tr> </tbody> </table>	11/45		11/50		11/55		<p>DRN.</p> <table border="1" style="display: inline-table;"> <tbody> <tr><td>R. COOK</td><td>2/22/72</td></tr> </tbody> </table>	R. COOK	2/22/72	<p>DATE</p>	<p>TITLE</p>
DATE	CHG. NO.	REV																				
RG	KT11-C-1	A																				
12/75	KT11-C-2	B																				
11/45																						
11/50																						
11/55																						
R. COOK	2/22/72																					
<p>CHK'D.</p>		<p>DATE</p>	<p>MEMORY MANAGEMENT UNIT</p>																			
<p>PROV. ENG.</p> <p><i>R.C. Gray</i></p>		<p>DATE</p> <p>4-26-72</p>																				
<p>PROD.</p> <p><i>W. H. Gray</i></p>		<p>DATE</p> <p>5/1/72</p>																				
<p>FIELD SERV.</p> <p><i>Chet Jones</i></p>		<p>DATE</p> <p>5/1/72</p>																				
<p>SHEET 1 OF 3</p>		<p>SIZE CODE</p> <p>B DD</p>	<p>NUMBER</p> <p>KT11-C</p>	<p>REV</p> <p>B</p>																		

**DIGITAL EQUIPMENT CORPORATION**  
MAYNARD, MASSACHUSETTS

**ACCESSORY LIST**

**LEGEND**

- D DOCUMENT
- DN DOCUMENT CHANGE NOTICE
- PA PAPER TAPE ASCII
- PB PAPER TAPE BINARY
- PM PAPER TAPE READ-IN-MODE

**QUANTITY / VARIATION**

MADE BY: Lawrence      CHECKED J. L. ...      SECTION  
 DATE 6-15-72      DATE 6-15-72  
 ENG R.C. Gray      PROD Jack Lowman      ISSUED SECT.  
 DATE 6/19/72      DATE 6-20-72

ITEM NO.	DWG NO. / PART NO.	DESCRIPTION	QUANTITY / VARIATION						KIT CHECK	BY	DATE	INSTALLATION CHECK	BY	DATE
			KT11-C	KT11-CD										
	KT11-C	Print Set	1	1										
	Lib Kit 11-KT11C-A-K	Software Kit	1	1										
	Dec 11-HKTA-D	Maint. Manual (KT-11C	1	1										

TITLE: Memory management unit      ASSY. NO.   /  /        SIZE CODE **A AL**      NUMBER: KT11-C      REV. **A**      ECO NO: KT11-C-00002

SHEET    OF         DIST.

This drawing and specifications, herein, are the property of Digital Equipment Corporation and shall not be reproduced or copied or used in whole or in part in the manufacture or use of items without written permission.

**NOTE**

I. FOR 11/45 SYSTEMS BUILT WITH 860 POWER CONTROLS, REFER TO D-IC-11/45-0-1 REV. A DRAWING.

**TABLE I**  
POWER SYSTEM - MAJOR ECO SUMMARY  
ECO# D-IC-11/45-0-1 DESCRIPTION  
REV CHANGES (PROBLEM-SOLUTION)  
FROM REV TO REV

11/45-00031	A	B	REPLACED OBSOLETE 860 POWER CONTROL WITH 861 POWER CONTROL. (D-IC-11/45-0-1 REV. A DOCUMENTS MACHINES WITH 860 POWER CONTROL.)
11/45-00054	C	D	POWER DISTRIBUTION REDESIGNED TO ACCOMMODATE H754 REGULATOR (+20V±5V) FOR 16K MEMORY. MAIN POWER HARNESS CHANGED FROM 7008784 TO 7009540. SYSTEM UNIT POWER DISTRIBUTION MOVED FROM BACK OF CPU BOX TO TOP REAR OF CPU BOX. SYSTEM UNIT CONNECTORS CHANGED FROM FLAT 8-PIN CONNECTOR TO 15-PIN AND 6-PIN RECTANGULAR CONNECTOR-PAIR. MACHINES WITH THIS ECO HAVE SERIAL NO'S ≥ 2000.
11/45-00057	D	E	7009540 HARNESS REVISED TO DISTRIBUTE -15V TO SYSTEM UNITS WHEN H754 REGULATOR IS INSTALLED FOR 16K MEMORY. P45/J45 (FLAT 4-PIN CONNECTORS) ADDED TO HARNESS NEAR P7. (AFFECTS ONLY MACHINES WITH S/N ≥ 2000).
11/45-00060	E	F	+5V FROM SLOT D H744 REWIRED TO LOWER VOLTAGE DROPS TO SYSTEM UNITS.
11/45-00061	F	H	CPU HARNESS MODIFIED TO ACCOMMODATE SECOND H746 MOS REGULATOR. ADD P30 TO 7009540 HARNESS (NEAR P29 MACHINE WITH S/N ≥ 2000). IF S/N < 2000 P30 OF THE 7008784 HARNESS IS REWIRED TO DISTRIBUTE MOS VOLTAGE FROM AN H746 IN SLOT L OF THE LOWER H742. KB11-A ECO* MUST BE INSTALLED AT SAME TIME.

90-135V/47-63HZ  
(2-PHASE 120° OR 180° DISPLACED) OR  
180-270V/47-63HZ  
SINGLE PHASE

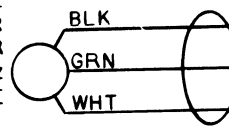

**\*861 POWER CONTROL**

REFER TO CIRCUIT SCHEMATIC  
D-CS-861-A-1 OR  
D-CS-861-B-1

861-A: NEMA L14-20P CONNECTOR  
861-B: NEMA L6-20P CONNECTOR

SWITCHED AND UNSWITCHED AC OUTLETS ARE INDICATED BY PANEL MARKINGS.

\*861-A: 90-135V/47-63HZ 2-PHASE (120° OR 180° DISPLACED)  
861-B: 230V/60HZ

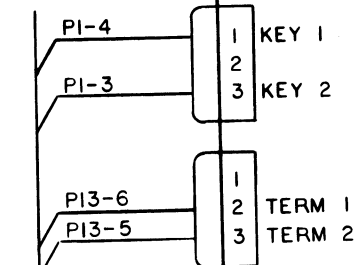

PART OF POWER DISTRIBUTION CABLE HARNESS

**UPPER H742 POWER SUPPLY**  
REFER TO D-CS-H742-0-1

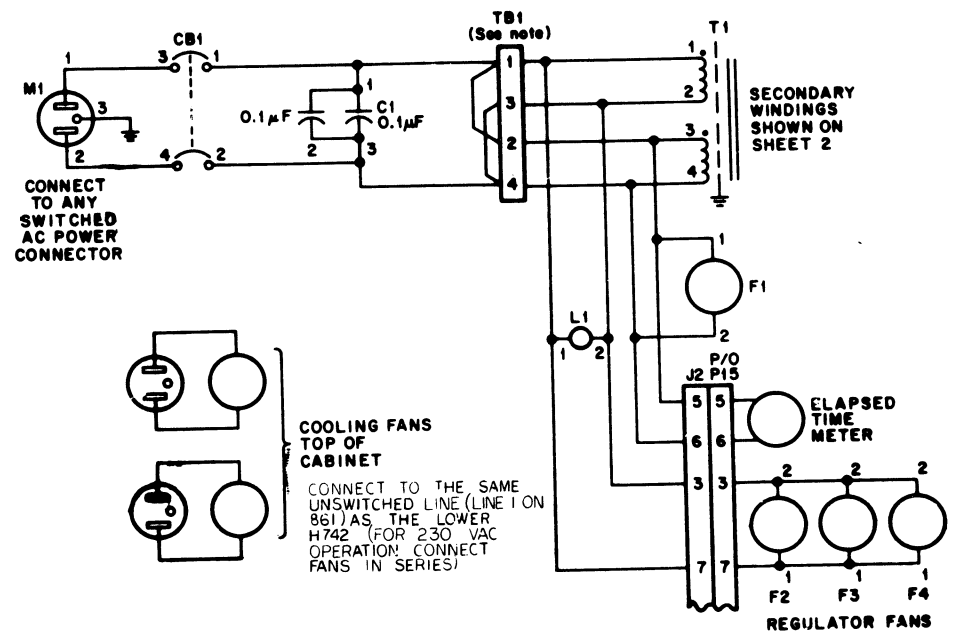

**LOWER H742 POWER SUPPLY**

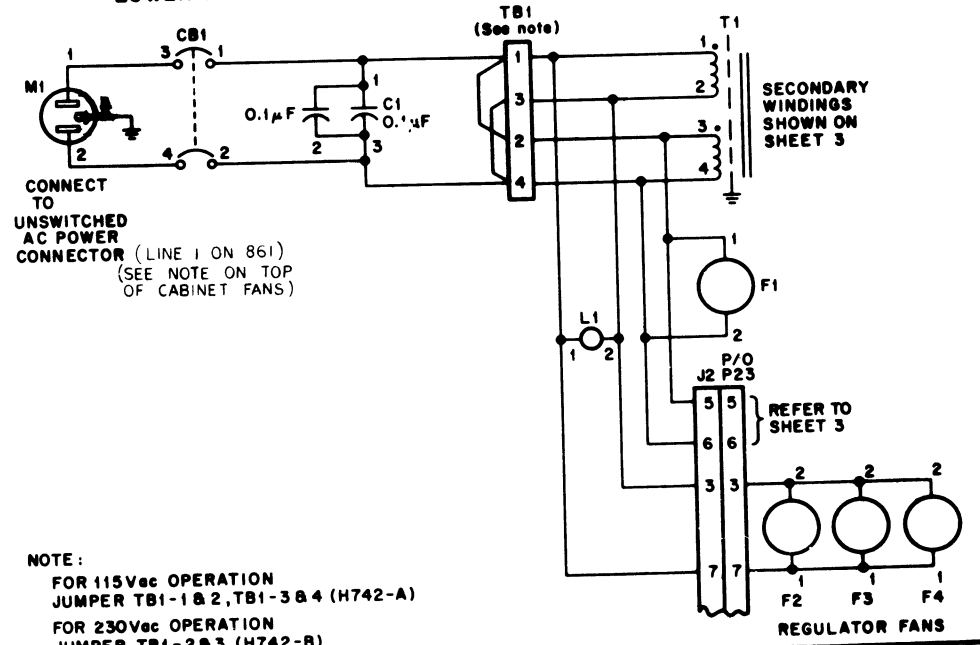

NOTE:  
FOR 115V<sub>ac</sub> OPERATION  
JUMPER TB1-1 & 2, TB1-3 & 4 (H742-A)  
FOR 230V<sub>ac</sub> OPERATION  
JUMPER TB1-2 & 3 (H742-B)

TABLE 2

MEMORY CONFIGURATION	REGULATOR SLOTS				JUMPERS		
	H	J	K	L	+5V2 (P5-7&8)	+5V1 (P5-3&4)	+5V3 (P6-7&8)
<b>BIPOLAR ONLY</b>							
1-2K	H744	X	X	X	IN	IN	IN
3-4K	H744	X	X	X	IN	IN	IN
5-6K	H744	X	X	X	IN	IN	IN
7-8K	H744	X	X	X	IN	IN	IN
<b>MOS ONLY</b>							
4-16K	H746	H744	X	X	IN	IN	IN
16-32K	H746	H744	X	H746	IN	IN	IN
<b>MIXED-MOS/BIPOLAR</b>							
4-16K MOS; 1-2K BIPOLAR	H746	H744	H744	X	IN	X	IN
4-16K MOS; 3-4K BIPOLAR	H746	H744	H744	H744	IN	X	X

FIRST USED ON OPTION/MODEL	QTY.	DESCRIPTION	PART NO.	ITEM NO.
11/45				
PARTS LIST				
UNLESS OTHERWISE SPECIFIED DIMENSION IN INCHES:		digital EQUIPMENT CORPORATION		
DECIMALS	ANGLES	TITLE		
.xxx - .006	±0° 30'	POWER SYSTEMS CONFIGURATION		
.xx - .02		SIZE CODE		
.x - .1		NUMBER		
REMOVE BURRS AND BREAK SHARP CORNERS SURFACE QUALITY		REV.		
MATERIAL		D IC 11/45-0-1		
FINISH		SCALE		
		SHEET 1 OF 5		
		DIST.		

REV.	CHANGE NO.	DATE	BY	CHK
A	11/45-00031	8-22-72	SWANSON	
B	11/45-00047	7-17-72	MINOR	
C	11/45-00052	7-6-72	BOEN	
D	11/45-00054	7-7-72	BOEN	
E	11/45-00057	7-21-72	BOEN	
F	11/45-00060	7-21-72	BOEN	
G	11/45-00061	7-21-72	BOEN	
H	11/45-00061	7-21-72	BOEN	
I	11/45-00061	7-21-72	BOEN	

"THIS DRAWING AND SPECIFICATIONS HEREIN, ARE THE PROPERTY OF DIGITAL EQUIPMENT CORPORATION AND SHALL NOT BE REPRODUCED OR COPIED OR USED IN WHOLE OR IN PART AS THE BASIS FOR THE MANUFACTURE OR SALE OF ITEMS WITHOUT WRITTEN PERMISSION. COPYRIGHT © 1973 DIGITAL EQUIPMENT CORPORATION"

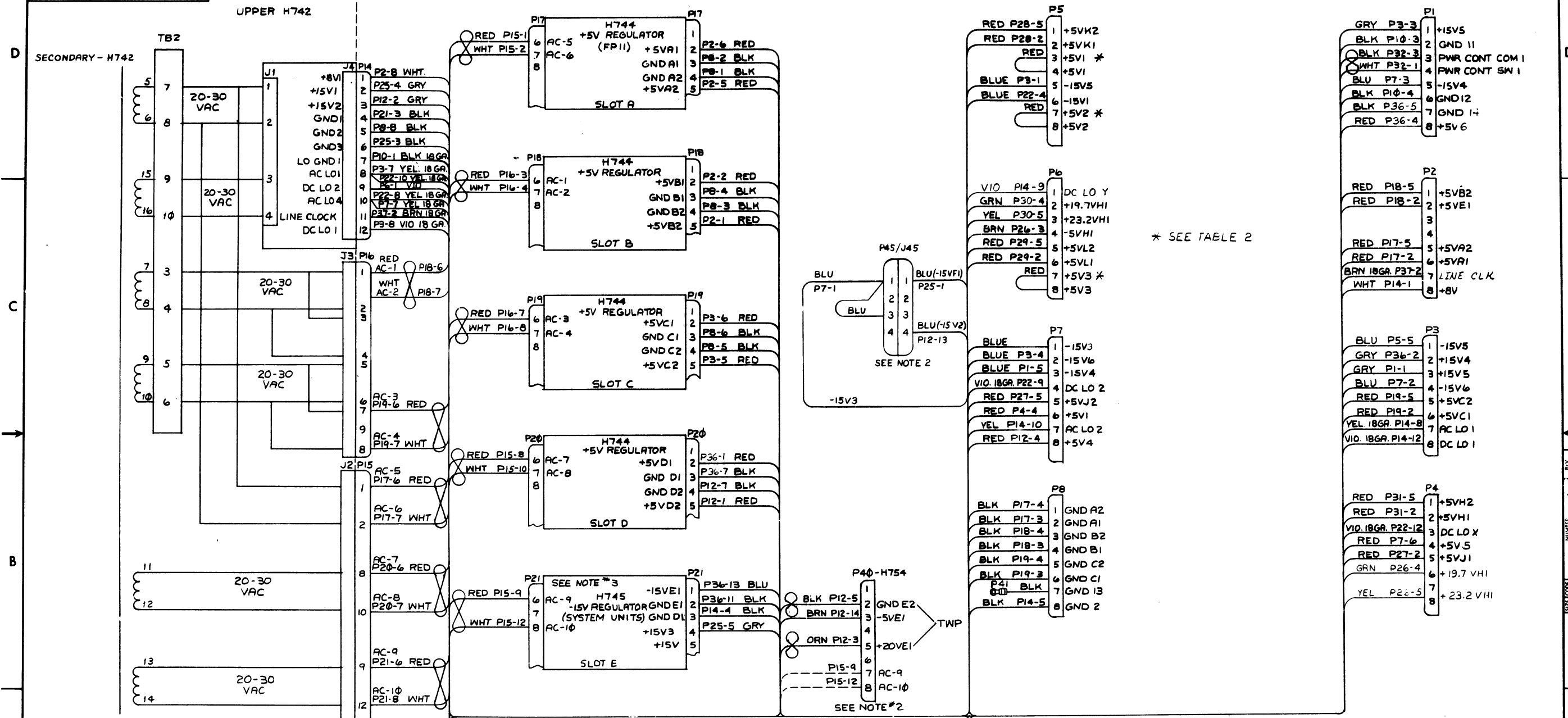

\* SEE TABLE 2

FIRST USED ON OPTION/MODEL	QTY.	DESCRIPTION	PART NO.	ITEM NO.
11/45				
PARTS LIST				
UNLESS OTHERWISE SPECIFIED DIMENSION IN INCHES	DRN. R. Counter	DATE 8/16/73	<b>digital</b> EQUIPMENT CORPORATION MAYNARD MASSACHUSETTS	
TOLERANCES	CHK'D.	DATE		
DECIMALS	ENG.	DATE	TITLE 11/45 POWER SYSTEM (UPPER H742)	
ANGLES	PROJ. ENG.	DATE		
.xxx = .006 .xx = .02 .x = .1	REMOVE BURRS AND BREAK SHARP CORNERS SURFACE QUALITY 1	DATE	SIZE CODE NUMBER D I C 11 / 45 - 0 - 1 REV. H	
MATERIAL	NEXT HIGHER ASSY.	DATE		
FINISH	SCALE NONE	SHEET 2 OF 5	DIST.	

REV.	CHANGE NO.
1	
2	
3	
4	
5	
6	
7	
8	
9	
10	
11	
12	
13	
14	
15	

THIS DRAWING AND SPECIFICATIONS HEREIN ARE THE PROPERTY OF DIGITAL EQUIPMENT CORPORATION AND SHALL NOT BE REPRODUCED OR COPIED OR USED IN WHOLE OR IN PART AS THE BASIS FOR THE MANUFACTURE OR SALE OF ITEMS WITHOUT WRITTEN PERMISSION. COPYRIGHT © 1973 DIGITAL EQUIPMENT CORPORATION.

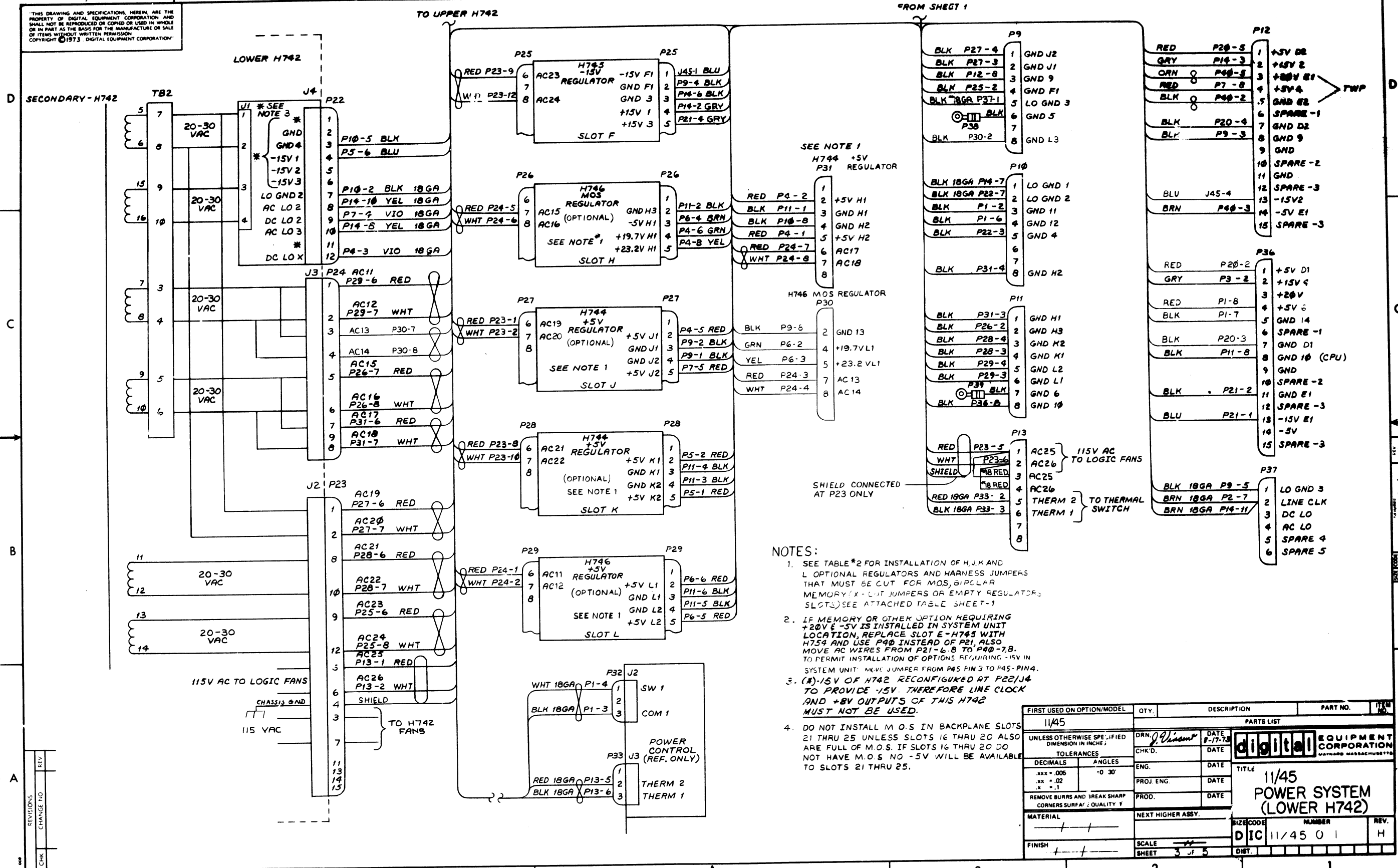

- NOTES:**
- SEE TABLE #2 FOR INSTALLATION OF H, J, K AND L OPTIONAL REGULATORS AND HARNESS JUMPERS THAT MUST BE CUT FOR MOS, BIPOLAR MEMORY, X-RAY JUMPERS OR EMPTY REGULATOR SLOTS. SEE ATTACHED TABLE SHEET-1.
  - IF MEMORY OR OTHER OPTION REQUIRING +20V & -5V IS INSTALLED IN SYSTEM UNIT LOCATION, REPLACE SLOT E - H745 WITH H754 AND USE P40 INSTEAD OF P21. ALSO MOVE AC WIRES FROM P21-6, 8 TO P40-7, 8. TO PERMIT INSTALLATION OF OPTIONS REQUIRING -15V IN SYSTEM UNIT: MOVE JUMPER FROM P45 PIN 3 TO P45-PIN 4.
  - (\*) -15V OF H742 RECONFIGURED AT P22/J4 TO PROVIDE -15V. THEREFORE LINE CLOCK AND +8V OUTPUTS OF THIS H742 MUST NOT BE USED.
  - DO NOT INSTALL M.O.S. IN BACKPLANE SLOTS 21 THRU 25 UNLESS SLOTS 16 THRU 20 ALSO ARE FULL OF M.O.S. IF SLOTS 16 THRU 20 DO NOT HAVE M.O.S. NO -5V WILL BE AVAILABLE TO SLOTS 21 THRU 25.

FIRST USED ON OPTION/MODEL	QTY.	DESCRIPTION	PART NO.	REV.
11/45				
PARTS LIST				
UNLESS OTHERWISE SPECIFIED DIMENSION IN INCHES				
TOLERANCES				
DECIMALS	ANGLES	DATE	DATE	
.xxx = .006	.0 30'	ENG.	DATE	
.xx = .02		PROJ. ENG.	DATE	
.x = .1		PROD.	DATE	
REMOVE BURRS AND BREAK SHARP CORNERS SURFACE QUALITY V				
MATERIAL	NEXT HIGHER ASSY.		SIZE CODE	NUMBER
FINISH	SCALE	SHEET	D I C	11/45 0 1
	3 of 5	DIST.		H

REV.	CHANGE NO.	DESCRIPTION

This drawing and specifications, herein, are the property of Digital Equipment Corporation and shall not be reproduced or copied or used in whole or in part as the basis for the manufacture or sale of items without written permission.

UPPER H742 POWER SUPPLY

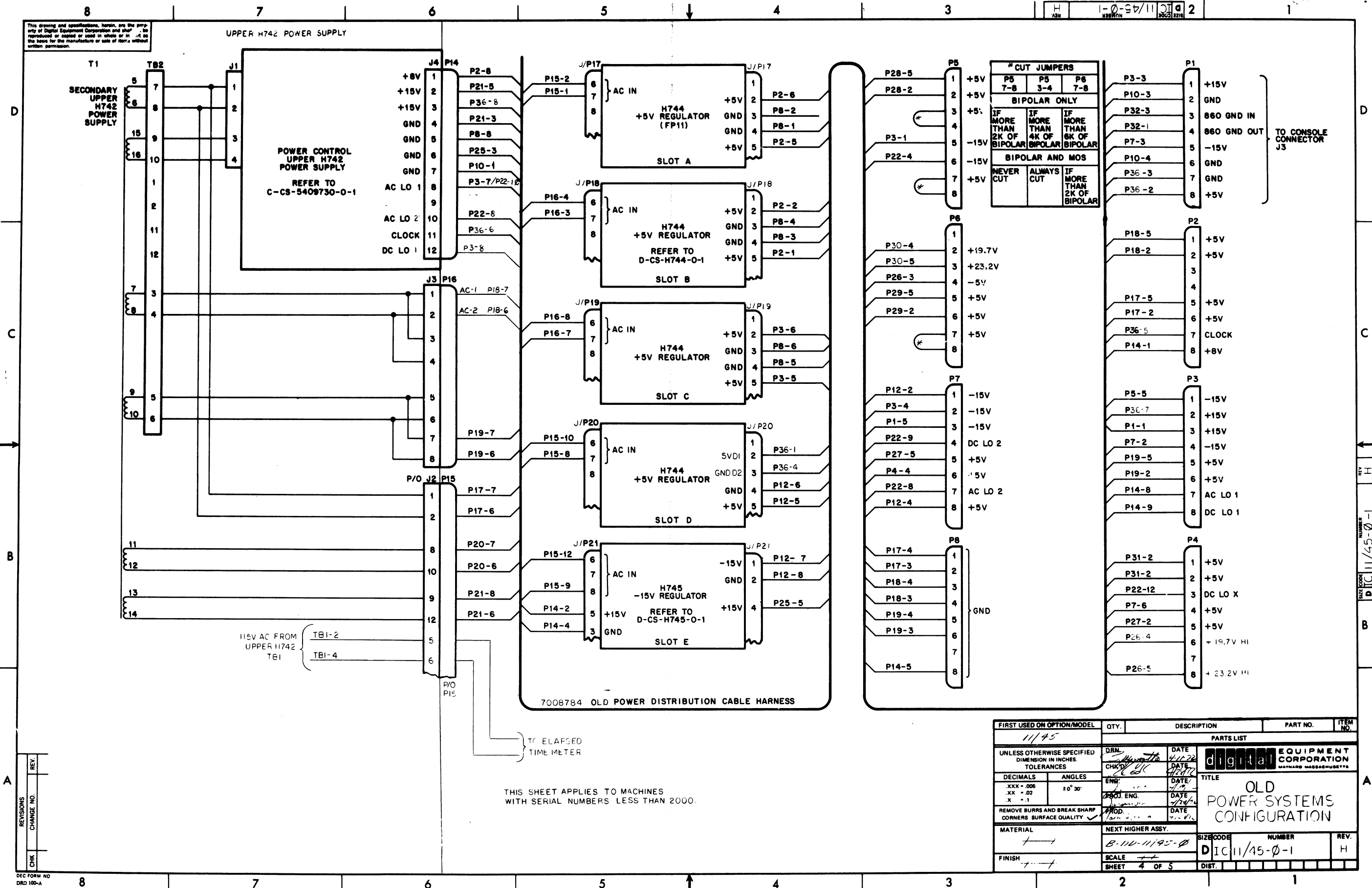

CUT JUMPERS		
P5 7-8	P5 3-4	P6 7-8
BIPOLAR ONLY		
IF MORE THAN 2K OF BIPOLAR	IF MORE THAN 4K OF BIPOLAR	IF MORE THAN 8K OF BIPOLAR
NEVER CUT	ALWAYS CUT	IF MORE THAN 2K OF BIPOLAR

7008784 OLD POWER DISTRIBUTION CABLE HARNESS

THIS SHEET APPLIES TO MACHINES WITH SERIAL NUMBERS LESS THAN 2000.

FIRST USED ON OPTION/MODEL	QTY.	DESCRIPTION	PART NO.	ITEM NO.
11/45		PARTS LIST		
UNLESS OTHERWISE SPECIFIED DIMENSION IN INCHES. TOLERANCES		DRN. DATE 4/16/72	digital EQUIPMENT CORPORATION	
DECIMALS .XXX - .006	ANGLES ±0° 30'	CHKD. DATE 4/24/72	TITLE	
REMOVE BURRS AND BREAK SHARP CORNERS SURFACE QUALITY		ENG. DATE 4/19/72	OLD POWER SYSTEMS CONFIGURATION	
MATERIAL	NEXT HIGHER ASSY.	PROD. DATE 4/24/72	SIZE CODE	NUMBER
FINISH	B-110-11/45-0	DIST. DATE	DIC 11/45-0-1	REV. H
SCALE		SHEET 4 OF 5		

REV.	CHANGE NO.

This drawing and specifications herein are the property of Digital Equipment Corporation and shall not be reproduced or copied or used in whole or in part as the basis for the manufacture or sale of items without written permission.

LOWER H742 POWER SUPPLY

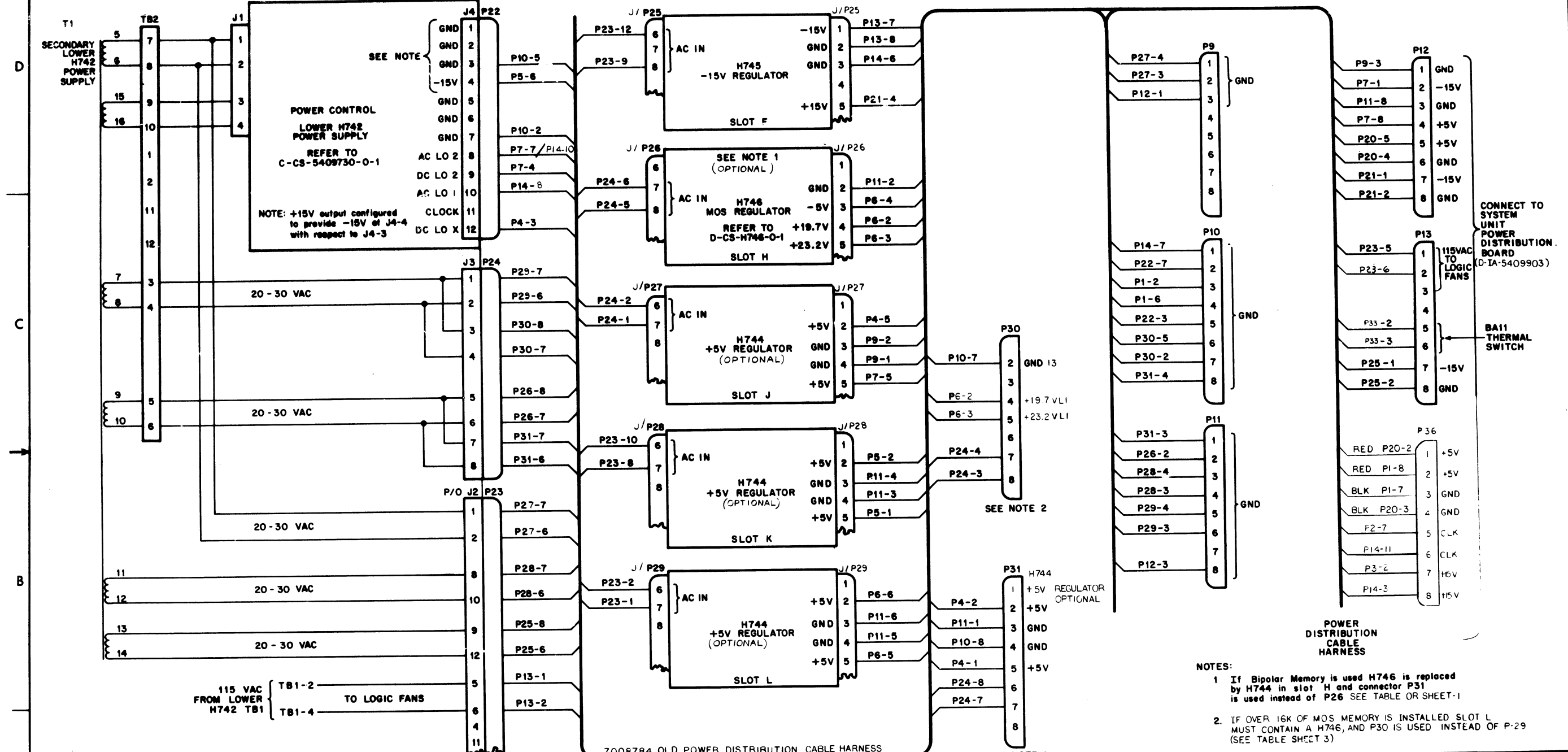

POWER CONTROL  
LOWER H742  
POWER SUPPLY  
REFER TO  
C-CS-5409730-0-1

NOTE: +15V output configured to provide -15V at J4-4 with respect to J4-3

H745  
-15V REGULATOR  
SLOT F

SEE NOTE 1  
(OPTIONAL)  
H746  
MOS REGULATOR  
REFER TO  
D-CS-H746-0-1  
SLOT H

H744  
+5V REGULATOR  
(OPTIONAL)  
SLOT J

H744  
+5V REGULATOR  
(OPTIONAL)  
SLOT K

H744  
+5V REGULATOR  
(OPTIONAL)  
SLOT L

- NOTES:
- 1 If Bipolar Memory is used H746 is replaced by H744 in slot H and connector P31 is used instead of P26 SEE TABLE OR SHEET-1
  - 2 IF OVER 16K OF MOS MEMORY IS INSTALLED SLOT L MUST CONTAIN A H746, AND P30 IS USED INSTEAD OF P-29 (SEE TABLE SHEET 3)

7008784 OLD POWER DISTRIBUTION CABLE HARNESS

THIS SHEET APPLIES TO MACHINES WITH SERIAL NUMBERS LESS THAN 2000

FIRST USED ON OPTION/MODEL	QTY.	DESCRIPTION	PART NO.	ITEM NO.
11/45				
PARTS LIST				
UNLESS OTHERWISE SPECIFIED DIMENSION IN INCHES TOLERANCES	DATE 4-11-72	DATE 7-12-72	DATE 7-12-72	DATE 7-12-72
DECIMALS .XXX ± .006 .XX ± .02 .X ± .1	ANGLES ± 0° 30'	DATE 7-12-72	DATE 7-12-72	DATE 7-12-72
REMOVE BURRS AND BREAK SHARP CORNERS SURFACE QUALITY	PROJ. ENG.	DATE 7-12-72	DATE 7-12-72	DATE 7-12-72
MATERIAL	NEXT HIGHER ASSY.	DATE 7-12-72	DATE 7-12-72	DATE 7-12-72
FINISH	SCALE	SIZE CODE	NUMBER	REV.
	SHEET 5 OF 5	B-DD-11/45-0	DIC 11/45-0-1	H

OLD POWER SYSTEMS CONFIGURATION

REV H  
D I C 11/45-0-1

REV.	
CHANGE NO.	
CHK.	

This drawing and specifications, herein, are the property of Digital Equipment Corporation and shall not be reproduced or copied or used in whole or in part as the basis for the manufacture or sale of items without written permission.

VOLTAGE	REGULATOR LOCATION	PIN	ROW	SLOT	MATE N LOCK CONNECTION	WIRE WRAP PIN
+5V	A	A2, V1	A-F	2-5	J2-5, 6	
	B	A2		1, 6-9	J2-3, 4	
	B	V1		6-9	J2-3, 4	
	C	A2, V1		10-15	J3-5, 6	
	J			16-18	J4-6, 7	
	H2			19, 20	J4-1, 2, J5-8	
	K			21-23	J5-1, 2, 3	
	L	A2, V1	A-F	24, 25	J6-5, 6, 7	
	J	A2	A	16	J5-4, 7, J6-8	
	D		A, B	26	J7-8	
	D		C-F	26-28	J7-8	
+5V	J	A2	A, B	27, 28	J7-5, 6	
+8V	TOP H742	B1	F	1	J2-8	SP-1
LTCL	TOP H742	R1	C	1	J2-7	
DCLOY	TOP H742				J6-1	SPIO
DCLO1	TOP H742	U1	C	12	J3-8	
ACLO1	TOP H742	S1	C	12	J3-7	
-15V	E	B2	E	2	J3-4	SP-3
+15V	TOP H742	A1	E	15	J3-2, 3	SP-4
-15V	BOT. H742	B2	E	16	J3-1	SP-5
+23.2VLI	L2	V2	A, C, E	22-25	J6-3	
+19.7VLI	L2	U2	A, C, E	22-25	J6-2	
DCLOX	BOT. H742	U2	B	16	J4-3	
-15V	BOT. H742	B2	E	21	J5-5, 6	SP-8
-5V	H1	C1	F	17-20, 22-25	J6-4	SP-9
+23VHI	H1	V2	A, C, E	17-20	J4-8	SP-6
+19VHI	H1	U2	A, C, E	17-20	J4-6	SP-7
ACLOZ	BOT. H742	F1	B	28	J7-7	
DCLOZ	BOT. H742	F2	E	28	J7-4	

	PIN	ROW	SLOT	MATE N LOCK CONNECTION
GROUND	C2, N2, T1	A-F	2-25	J8-1, 8
	C2, T1	A-F	1, 26-28	J9-1, 8
	B2, V2	A, B		J10-1, 8
	N1, P1, R1, S1	A		J11-1, 8
	D1, E1	B	1, 26-28	

NOTES:  
 1. THIS LISTING IS FURNISHED TO SHOW COMBINATIONS OF MATE N LOCK CONNECTORS (J#) AND WIREWRAP PINS THAT ARE TO BE ETCHED TOGETHER. VOLTAGES WILL BE WIREWRAPPED BETWEEN 5409910 AND 5409912  
 2. ALL MATE N LOCK CONNECTORS AND PINS LISTED ARE CONNECTED TOGETHER BY THE GROUND PLANE (5409910-4 HIGH BOARD). WIREWRAP CONNECTIONS WILL BE MADE BETWEEN DXXT1 (5409910) AND EXXC2 (5409912)-XX= SLOT NUMBERS 01-28

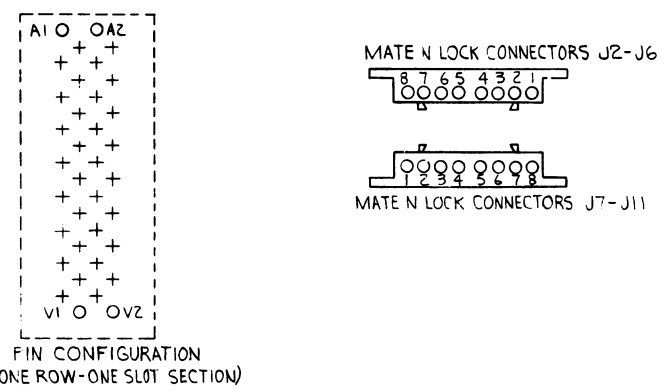
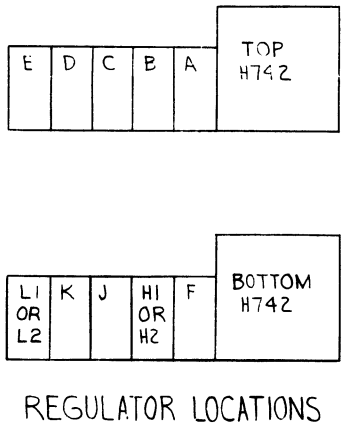
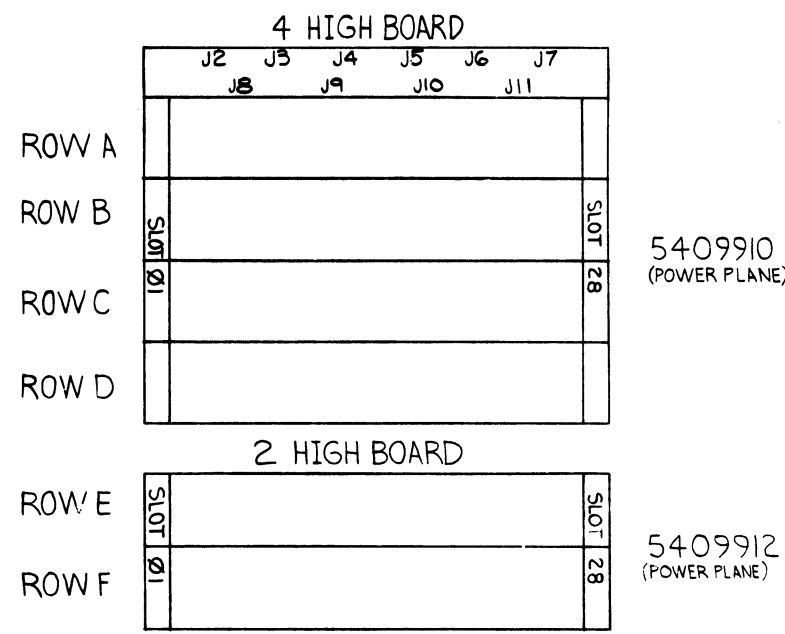

REV.	CHANGE NO.	DATE	BY
A	11/45-00061	4-10-75	V. BOAEN

FIRST USED ON OPTION/MODEL	QTY.	DESCRIPTION	PART NO.	ITEM NO.
PDP11/45				
PARTS LIST				
UNLESS OTHERWISE SPECIFIED DIMENSION IN INCHES. TOLERANCES		DRN: <i>Roberts</i> DATE: 4/26/72	digital EQUIPMENT CORPORATION MAYNARD MASSACHUSETTS	
DECIMALS	ANGLES	CHK'D: <i>[Signature]</i> DATE: 4/27/72	TITLE: 11/45 BACK PANEL PC BOARD	
.xxx = .005	±0° 30'	ENG: <i>[Signature]</i> DATE: 4/29/72	SIZE CODE: D I C	
.xx = .02		PROJ. ENG: <i>[Signature]</i> DATE: 4/29/72	NUMBER: 11/45-0-2	
.x = .1		PROD. <i>[Signature]</i> DATE: 5-1-72	REV. A	
REMOVE BURRS AND BREAK SHARP CORNERS SURFACE QUALITY		NEXT HIGHER ASSY.	SCALE: ---	
MATERIAL: ---		B-DD-11/45-0	SHEET 1 OF 1	
FINISH: ---		DIST.		

REV. A  
 NUMBER 11/45-0-2  
 SIZE CODE D I C

This drawing and specifications, herein, are the property of Digital Equipment Corporation and shall not be reproduced or copied or used in whole or in part as the basis for the manufacture or sale of items without written permission. COPYRIGHT 1973

DIGITAL EQUIPMENT CORPORATION

REV. C | NUMBER 7009540-0-2 | SIZE CODE K WL | 2

4

3

1

B

B

A

A

REVISIONS	
CHK	CHANGE NO.
27	11/45-00057
	(S. W. 3-21-74)
	V. BOAEN
	<i>V. Boalen</i>
82	11/45-00060
	(S. W. 3-16-74)
	V. BOAEN
	<i>V. Boalen</i>
88	11/45-00061
	(S. W. 4-2-75)
	V. BOAEN
	<i>V. Boalen</i>

FIRST USED ON OPTION MODEL	QTY.	DESCRIPTION	PART NO.	ITEM NO.
11/45				
PARTS LIST				
DRN.	DATE	 <b>digital</b> EQUIPMENT CORPORATION <small>MAYNARD, MASSACHUSETTS</small>		
<i>B. Blagovest</i>	10-5-73			
CHK'D.	DATE			
<i>A. Labing</i>	11/5/73			
ENG.	DATE			
<i>V. Boalen</i>	11/5/73	TITLE  WIRE LIST		
PROJ. ENG.	DATE			
<i>V. Boalen</i>	11/5/73			
PROD.	DATE			
<i>V. Boalen</i>	11-5-73			
NEXT HIGHER ASSEMBLY				
J-IA-7009540-0-0		SIZE CODE	NUMBER	REV.
SCALE		K WL	7009540-0-2	C
SHEET 1 OF 1		DIST.		

4

3

1

WRLJJD.SAV(JJB)	15-MAR-72	15-MAR-75	REMARKS	NEW RUN INDICATOR	1515	PAGE 1					
NAME SORT	NAME SORT	NAME SORT	NAME SORT	NAME SORT	NAME SORT	NAME SORT					
A/P	PIN LOCATION	BAY Ø	DRAW KV	RG	Y	X	Z	LEVEL	NEW RUN INDICATOR	1515	PAGE 1
NOTE	NOTE	NOTE	NOTE	NOTE	NOTE	NOTE	NOTE	NOTE	NOTE	NOTE	NOTE
SEE NOTE!											
SEE NOTE!											
+15V1	P14-2										
+15V1	P25-4	42.25"									
+15V2	P14-2										
+15V2	P14-3	56.5"									
+15V3	P21-4										
+15V3	P25-5	51"									
+15V4	P3-2										
+15V4	P36-2	31.5"									
+15V5	P1-1										
+15V5	P3-3	18"									
+19.7VHJ	P26-4	96"									
+19.7VHJ	P4-6										
+19.7VLI	P30-4										
+19.7VLI	P6-2	81"									
+20VEJ	P12-3										
+20VEJ	P40-5	62.5"									
+23.2VHJ	P26-5	96"									
+23.2VHJ	P4-8										
+23.2VLI	P30-5										
+23.2VLI	P6-3	81"									
+5J1	P27-2	80"									
+5J1	P4-5										
+5V1	P5-3										
+5V1	P5-4	2.25"									
+5V2	P5-7										
+5V2	P5-8	2.25"									
+5V3	P6-7										
+5V3	P6-8	2.25"									
+5V4	P12-4	20.5"									
+5V4	P7-8										
+5V5	P4-4										
+5V5	P7-6	17"									
+5V6	P1-4	38"									
+5V6	P36-4										

ALL WIRES 014 AUG UNLESS OTHERWISE NOTED

GRN-BLK TMP(GND L2)

WRLJJD.SAV(JJB)	15-MAR-72	15-MAR-75	REMARKS	NEW RUN INDICATOR	1515	PAGE 2					
NAME SORT	NAME SORT	NAME SORT	NAME SORT	NAME SORT	NAME SORT	NAME SORT					
A/P	PIN LOCATION	BAY Ø	DRAW KV	RG	Y	X	Z	LEVEL	NEW RUN INDICATOR	1515	PAGE 2
NOTE	NOTE	NOTE	NOTE	NOTE	NOTE	NOTE	NOTE	NOTE	NOTE	NOTE	NOTE
+5VA1	P17-2	65"									
+5VA1	P2-6										
+5VA2	P17-5	65.5"									
+5VA2	P2-5										
+5VH2	P1A-5	64"									
+5VH2	P2-1										
+5VC1	P14-2	71"									
+5VC1	P3-6										
+5VC2	P14-5	71"									
+5VC2	P3-5										
+5VD1	P20-2	61"									
+5VD1	P34-1										
+5VD2	P12-1										
+5VD2	P20-5	59.5"									
+5VEL1	P1A-2	64"									
+5VEL1	P2-2										
+5VH1	P31-2	77"									
+5VH1	P4-2										
+5VH2	P31-5	77"									
+5VH2	P4-1										
+5VJ2	P27-5	72.5"									
+5VJ2	P7-5										
+5VK1	P2A-2	81.25"									
+5VK1	P5-2										
+5VK2	P2A-5	81"									
+5VK2	P5-1										
+5VL1	P24-2	81"									
+5VL1	P6-6										
+5VL2	P24-5	81"									
+5VL2	P6-5										
+AV	P14-1	71"									
+AV	P2-4										
-15V1	P22-4	76.5"									
-15V1	P5-6										
-15V2	J45-4	21"									
-15V2	P12-13										

RUN NAME	A/P	PIN LOCATION	BAY ORDER	DRAW RV	RG Y	X	Z LEVEL	REMARKS	NEW RUN INDICATOR	RUN NUM
-15V3		P07-1	4"				BLU	*10AUG	X	37
-15V3		P45-1	2"				BLU	*10AUG		37
-15V3		P45-3								37
-15V4		P1-5					BLU		X	38
-15V4		P7-3	27.75"							38
-15V5		P3-1					BLU		X	39
-15V5		P5-5	14.5"							39
-15V6		P3-4					BLU		X	40
-15V6		P7-2	19.5"							40
-15VEL1		P21-1					BLU		X	41
-15VEL1		P36-13	64"							41
-15VFL1		J45-1					BLU		X	42
-15VFL1		P25-1	65"							42
-5VEL1		P12-14					BRN		X	43
-5VEL1		P40-3	62.75"				BRN		X	43
-5VH1		P26-3	72.5"				YEL	*10AUG	X	44
-5VH1		P6-4								44
AC L01		P14-8	70.5				YEL	*10AUG	X	45
AC L01		P3-7								45
AC L01*		P14-8					YEL	*10AUG	X	46
AC L01*		P22-10	47"							46
AC L02		P14-10					YEL	*10AUG	X	47
AC L02		P7-7	60.25"							47
AC L02*		P14-10					YEL	*10AUG	X	48
AC L02*		P22-8	46"							48
AC01		P16-1						RED-WHT TWP(AC2)	X	49
AC01		P18-6	11"							49
AC02		P16-2						WHT-RED TWP(AC1)	X	50
AC02		P18-7	11"							50
AC03		P16-7						RED-WHT TWP(AC4)	X	51
AC03		P19-6	15.75"							51
AC04		P16-8						WHT-RED TWP(AC3)	X	52
AC04		P19-7	15.75"							52
AC05		P15-1						RED-WHT TWP(AC6)	X	53
AC05		P17-6	11.5"							53
AC06		P15-2						WHT-RED TWP(AC5)	X	54
AC06		P17-7	11.5"							54

RUN NAME	A/P	PIN LOCATION	BAY ORDER	DRAW RV	RG Y	X	Z LEVEL	REMARKS	NEW RUN INDICATOR	RUN NUM
AC07		P15-8						RED-WHT TWP(AC8)	X	55
AC07		P20-6	16"							55
AC08		P15-10						WHT-RED TWP(AC7)	X	56
AC08		P20-7	16"							56
AC09		P15-9						RED-WHT TWP(AC10)	X	57
AC09		P21-6	21.5"							57
AC10		P15-12						WHT-RED TWP(AC9)	X	58
AC10		P21-8	21.5"							58
AC11		P24-1						RED-WHT TWP(AC12)	X	59
AC11		P29-6	27"							59
AC12		P24-2						WHT-RED TWP(AC11)	X	60
AC12		P29-7	27"							60
AC13		P24-3						RED-WHT TWP(AC14)	X	61
AC13		P30-7	27"							61
AC14		P24-4						RED-WHT TWP(AC13)	X	62
AC14		P30-8	27"							62
AC15		P24-5						RED-WHT TWP(AC16)	X	63
AC15		P26-7	18"							63
AC16		P24-6						WHT-RED TWP(AC15)	X	64
AC16		P26-8	18"							64
AC17		P24-7						RED-WHT TWP(AC18)	X	65
AC17		P31-6	17.5"							65
AC18		P24-8						WHT-RED TWP(AC17)	X	66
AC18		P31-7	17.5"							66
AC19		P23-1						RED-WHT TWP(AC20)	X	67
AC19		P27-6	21"							67
AC20		P23-2						WHT-RED TWP(AC19)	X	68
AC20		P27-7	21"							68
AC21		P23-8						RED-WHT TWP(AC22)	X	69
AC21		P28-6	17.5"							69
AC22		P23-10						WHT-RED TWP(AC21)	X	70
AC22		P28-7	17.5"							70
AC23		P23-9						RED-WHT TWP(AC24)	X	71
AC23		P25-6	9.5"							71
AC24		P23-12						WHT-RED TWP(AC23)	X	72
AC24		P25-8	9.5"							72

KUN NAME	A/P	PIN LOCATION	BAY 0	DRAW RV	RG Y	X	Z LEVEL	REMARKS	NEW KUN INDICATOR	KUN NUM
AC25		P13-1			RED			*10AWG	X	73
AC25		P13-3			RED			*10AWG	X	73
AC25'		P13-1			RED			CABLE 9107761	X	74
AC25'		P23-5			RED			CABLE 9107761	X	74
AC26		P13-2			WMT			CABLE 9107761	X	75
AC26		P23-6			WMT			CABLE 9107761	X	75
AC26'		P13-2			WMT			*10AWG	X	76
AC26'		P13-4			WMT			*10AWG	X	76
AC27		P15-5						RED-WMT TWP TO TIME MTK	X	77
AC27		P34						RED-WMT TWP TO TIME MTK	X	77
AC28		P15-6						WMT-RED TWP TO TIME MTK	X	78
AC28		P35						WMT-RED TWP TO TIME MTK	X	78
DC L01		P14-12			VIO			*10AWG	X	79
DC L01		P3-8			VIO			*10AWG	X	79
DC L02		P22-9			VIO			*10AWG	X	80
DC L02		P7-4			VIO			*10AWG	X	80
DC L0X		P22-12			VIO			*10AWG	X	81
DC L0X		P4-3			VIO			*10AWG	X	81
DC L0Y		P14-9			VIO				X	82
DC L0Y		P6-1			VIO				X	82
GND 01		P14-4			BLK				X	83
GND 01		P21-3			BLK				X	83
GND 02		P14-5			BLK				X	84
GND 02		P8-8			BLK				X	84
GND 03		P14-6			BLK				X	85
GND 03		P25-3			BLK				X	85
GND 04		P10-5			BLK				X	86
GND 04		P22-3			BLK				X	86
GND 05		P3A			BLK				X	87
GND 05		P9-6			BLK				X	87
GND 06		P11-7			BLK				X	88
GND 06		P39			BLK				X	88
GND 09		P12-8			BLK				X	89
GND 09		P9-3			BLK				X	89
GND 10		P11-6			BLK				X	90
GND 10		P36-6			BLK				X	90

KUN NAME	A/P	PIN LOCATION	BAY 0	DRAW RV	RG Y	X	Z LEVEL	REMARKS	NEW KUN INDICATOR	KUN NUM
GND 11		P1-2			BLK				X	91
GND 11		P10-3			BLK				X	91
GND 12		P1-6			BLK				X	92
GND 12		P10-4			BLK				X	92
GND 13		P41			BLK				X	93
GND 13		P8-7			BLK				X	93
GND 14		P1-7			BLK				X	94
GND 14		P36-5			BLK				X	94
GND A1		P17-3			BLK				X	95
GND A1		P8-2			BLK				X	95
GND A2		P17-4			BLK				X	96
GND A2		P8-1			BLK				X	96
GND B1		P18-3			BLK				X	97
GND B1		P8-4			BLK				X	97
GND B2		P18-4			BLK				X	98
GND B2		P8-3			BLK				X	98
GND C1		P19-3			BLK				X	99
GND C1		P8-6			BLK				X	99
GND C2		P19-4			BLK				X	100
GND C2		P8-5			BLK				X	100
GND D1		P20-3			BLK				X	101
GND D1		P36-7			BLK				X	101
GND D2		P12-7			BLK				X	102
GND D2		P20-4			BLK				X	102
GND E1		P21-2			BLK				X	103
GND E1		P36-11			BLK				X	103
GND E2		P12-5			BLK			BLK-ORN TWP(+2UVEL1)	X	104
GND E2		P40-2			BLK				X	104
GND F1		P25-2			BLK				X	105
GND F1		P9-4			BLK				X	105
GND H1		P11-1			BLK				X	106
GND H1		P31-3			BLK				X	106
GND M2		P10-8			BLK				X	107
GND M2		P31-4			BLK				X	107
GND H3		P11-2			BLK				X	108
GND H3		P26-2			BLK				X	108

RUN NAME	A/P	PIN LOCATION	BAY # ORDER	DRAW RV	RG Y	X	Z LEVEL	REMARKS	NEW RUN INDICATOR	RUN NUM
GND J1		P27-3 82.5"						BLK	X	109
GND J1		P9-2								109
GND J2		P27-4 82.5"						BLK	X	110
GND J2		P9-1								110
GND K1		P11-4						BLK	X	111
GND K1		P28-3 78"								111
GND K2		P11-3						BLK	X	112
GND K2		P28-4 78"								112
GND L1		P11-6						BLK	X	113
GND L1		P29-3 81"								113
GND L2		P11-5						BLK	X	114
GND L2		P29-4 81"								114
GND L3		P30-2						BLK	X	115
GND L3		P9-8 89"								115
LINE CLOCK		P14-11						BRN	X	116
LINE CLOCK		P37-2 58.5"						#18AWG		116
LINE CLOCK'		P2-7						BRN	X	117
LINE CLOCK'		P37-2 33"						#18AWG		117
LO GND 01		P10-1						BLK	X	118
LO GND 01		P14-7 66"						#18AWG		118
LO GND 02		P10-2						BLK	X	119
LO GND 02		P22-7 78"						#18AWG		119
LO GND 03		P37-1 30.5"						BLK	X	120
LO GND 03		P9-5						#18AWG		120
PWR CONT COM1		P1-3						BLK=WHT	X	121
PWR CONT COM1		P32-3 98.25"						TWP(P.C SW1)#18AWG		121
PWR CONT SW1		P1-4						WHT=BLK	X	122
PWR CONT SW1		P32-1 98.25"						TWP(P.C COM1)#18AWG		122
SHIELD		P23-4							X	123
								CABLE 9107761		123
THERM 1		P13-6						BLK	X	124
THERM 1		P33-3 77.75"						#18AWG		124
THERM 2		P13-5						RED	X	125
THERM 2		P33-2 77.75"						#18AWG		125



# DRAWING DIRECTORY

"THIS DRAWING AND SPECIFICATIONS, HEREIN, ARE THE PROPERTY OF DIGITAL EQUIPMENT CORPORATION AND SHALL NOT BE REPRODUCED OR COPIED OR USED IN WHOLE OR IN PART AS THE BASIS FOR THE MANUFACTURE OR SALE OF ITEMS WITHOUT WRITTEN PERMISSION. COPYRIGHT © , DIGITAL EQUIPMENT CORPORATION"

## CUSTOMER PRINT SET INDEX

THIS IS PRINT SET 

--	--	--	--

- DRAWING DIRECTORY**  
POWER CONTROL, 861  
PILOT CONTROL  
CIRCUIT SCHEMATIC 861  
CIRCUIT SCHEMATIC 861  
CIRCUIT SCHEMATIC 861  
PACKAGING INSTRUCTION  
CIRCUIT SCHEMATIC 861

- B-DD-861-0  
E-UA-861-0-0  
D-CS-5411522-0-1  
D-CS-861-A-1  
D-CS-861-B-1  
D-CS-861-C-1  
A-PI-3700083-0-0  
D-CS-861-F-1

UNIT VARIATIONS		PRINT SET			
VAR	TITLE				
861-A	POWER CONTROL, 861-A				
861-B	POWER CONTROL, 861-B				
861-C	POWER CONTROL, 861-C				
861-F	POWER CONTROL, 861-F				

DEC 16-13251-1062-1A-R972

REVISIONS		USED ON OPTION/MODEL		DATE		TITLE	
DATE	CHG. NO.	REV					
2-73	861-3	A			9/13/72		861 POWER CONTROL
8-74	861-4	B			4/14/72		
12-74	861-6	C			9/23/72		
4-75	861-7	D					
7-75	861-8	E					
2-76	861-9	F					
4-76	861-10	H					
8-76	861-11	J					
9-76	861-12	K					
1-77	861-13	L					
DATE		CHG. NO.		DATE		TITLE	
FIELD SERV.			DATE		NUMBER		P/V
			9/25/72		861-0		L
SHEET			OF		DIST		

DWG. NO.	VAL. OUT	WIRE	AMP. OUT
861-A	180	2	12
861-B	180	2	12
861-C	180	1	24
861-F	180	1	12

VIEW B-B SEE NOTE 14 BASE

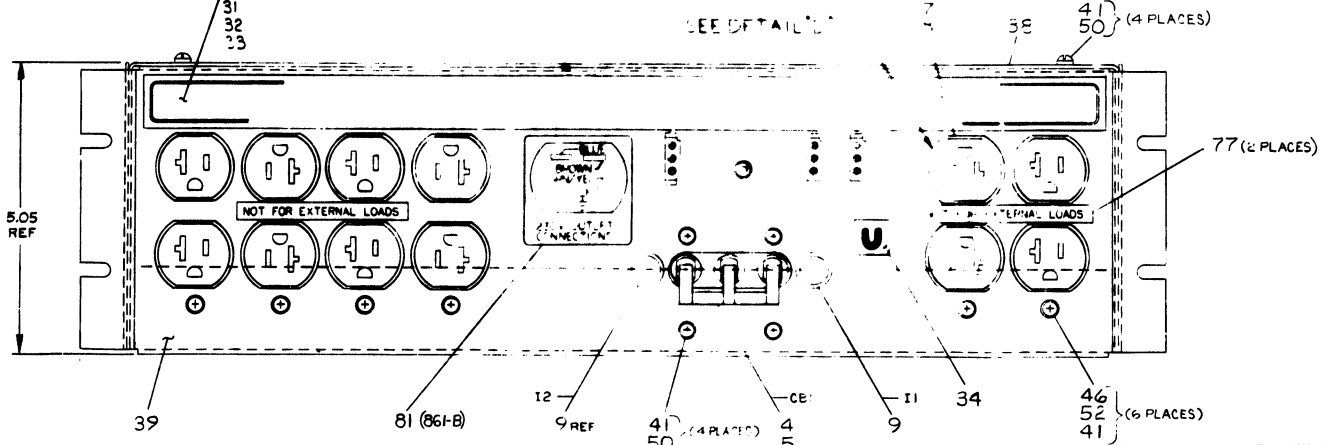
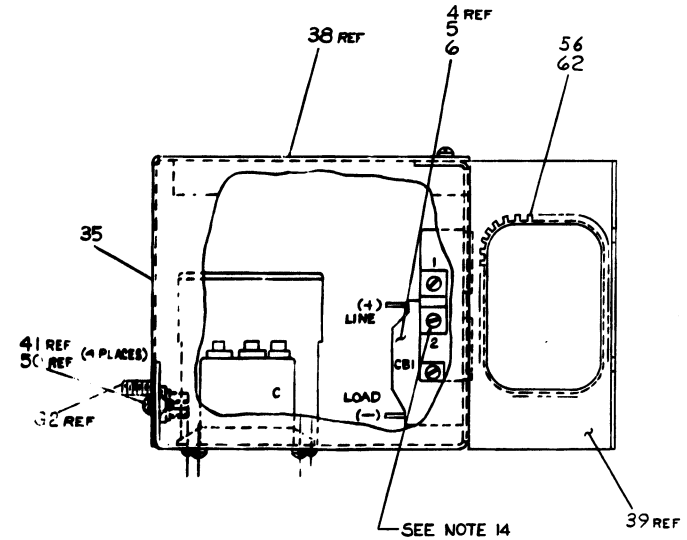
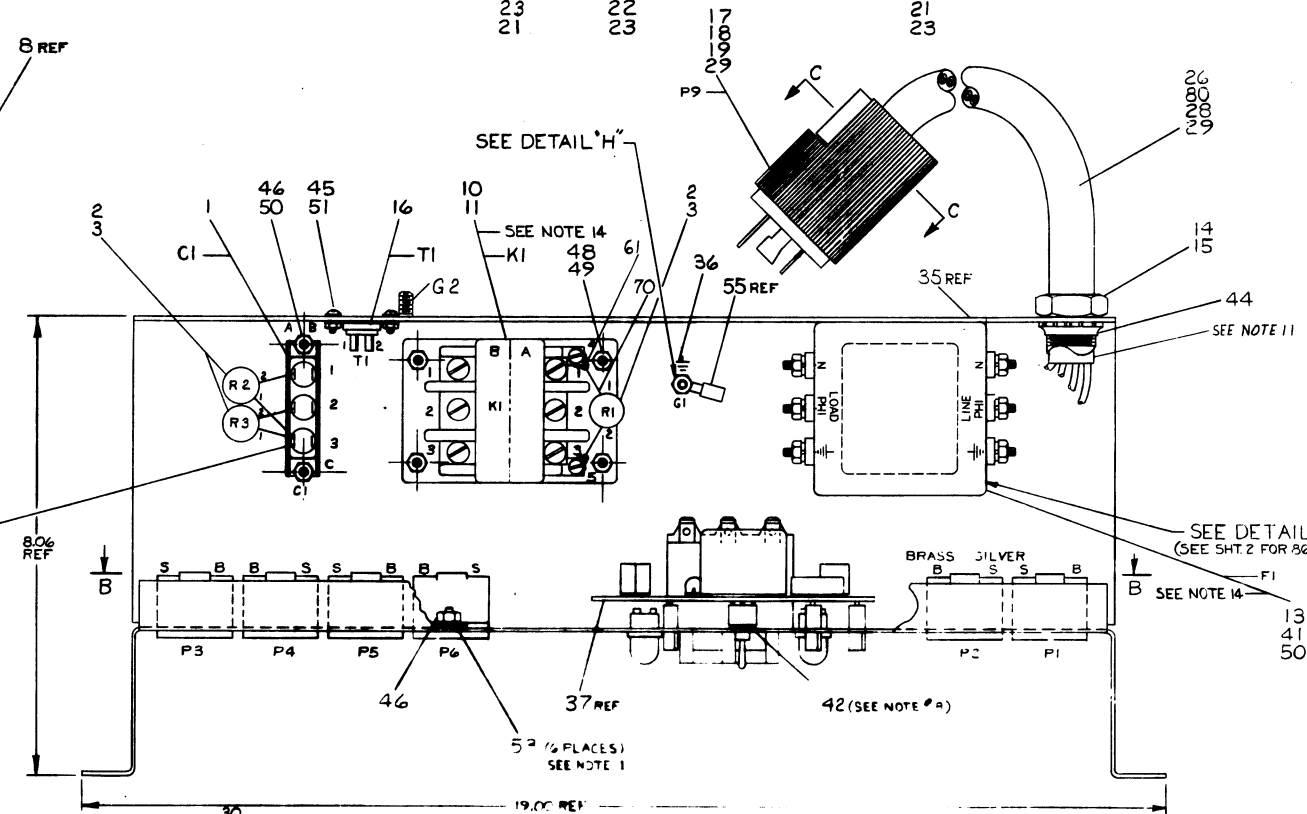
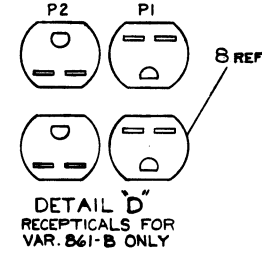
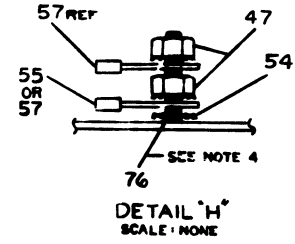
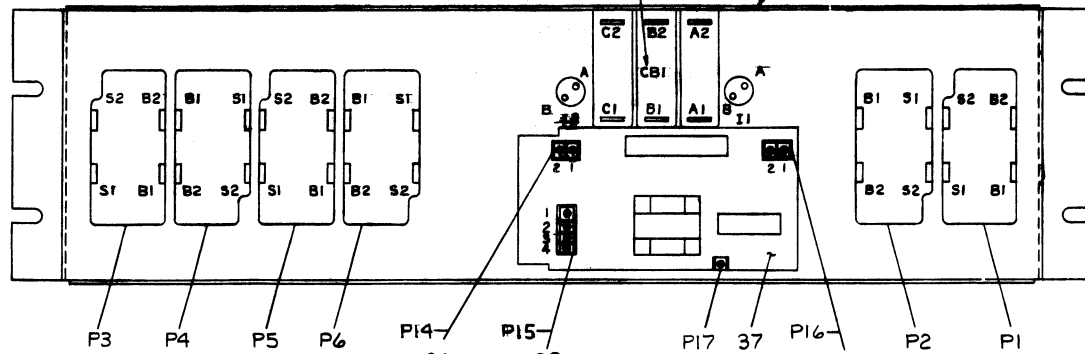

- NOTES:**
- ITEM 53 1/4 EXT WASHER MUST BE BETWEEN CHASSIS AND MOUNTING TAB OF RECEPTACLE (P1-P6).
  - REMOVE FASTEN-TABS FOR 861-F.
  - REMOVE FASTEN-TABS FOR 861-F.
  - REMOVE PAINT MASK FROM AROUND 10-32 GROUND STUD (G1) AND COAT EXPOSED SURFACE WITH CONDUCTIVE GREASE (ITEM 76) PLACE EXTERNAL TOOTH LOCK-WASHER (ITEM 54) ON STUD FIRST, THEN CRIMP LUG (FROM THIS LUG A WIRE GOES TO THE FILTER, LUG IS ITEM 55 OR 57) THEN KEPNUT (ITEM 47), THEN CRIMP LUG (ITEM 57, WIRE FROM THIS LUG GOES TO P.C. BOARD), AND LAST KEPNUT (ITEM 47). SEE DETAIL 'H'.
  - REMOVE ALL FASTENERS FROM FILTERS.
  - C1-3 IS THE COMMON(C) SIDE OF C1.
  - RECOMMENDED TORQUE LEVEL FOR VARIOUS HARDWARE SIZES:
- | THREAD | TORQUE      |
|--------|-------------|
| 3-32   | 10 INCH-LBS |
| 4-40   | 15 INCH-LBS |
| 5-16   | 20 INCH-LBS |
| 6-32   | 25 INCH-LBS |
| 8-32   | 35 INCH-LBS |
- TO PREVENT STRESS FROM SWITCH ON P.C. BOARD USE ITEM 42 (FIBER WASHER) BETWEEN CHASSIS AND P.C. BOARD
  - USE TIE WRAPS (ITEM 43) A/R.
  - REMOVE PAINT MASK FROM AROUND 10-32 STUD (G2) AND APPLY CONDUCTIVE GREASE (ITEM 76).
  - POWER CORD TO EXTEND APPROX. 50 IN. BEYOND LOCKNUT (ITEM 44) FOR ITEMS 27 & 29. ITEMS 26 & 28 TO REMAIN FLUSH WITH LOCKNUT.
  - RECOMMENDED TORQUE LEVEL FOR LUGS ON K1 (ITEMS 10 & 11) IS 10 INCH-LBS.
  - REF WIRE LIST. THESE CONNECTIONS HAVE THREE RING TERMINALS AND REQUIRE (ITEM 82) SCREW 8-32 x 1/4" WITH (ITEM 40) LOCKWASHER
  - REQUIRED TORQUE LEVELS FOR CERTAIN ELECTRO-MECHANICAL CONNECTIONS.
    - 18±2 IN-LBS FOR TERMINALS ON F1 (ITEMS 12 & 13). THE G LUG BOXES ON K1 (ITEMS 10 & 11) AND NUTS ON GROUND STUD G1.
    - 16±2 IN-LBS FOR 8-32 SCREW CONNECTIONS ON OUTLETS P1 THRU P6 (ITEMS 7 & 8).
    - 12±2 IN-LBS ON 3-32 SCREW CONNECTIONS ON CIRCUIT BREAKER CONNECTIONS CB1 (ITEMS 4, 5 & 6).

FOR PARTS LIST SEE A-PL-861-0-0

FIRST LISTED ON OPTION MODEL		QTY.	DESCRIPTION	PART NO.	REV.
861-PC					
DESIGNER: D. SCHMINTZ DATE: 5-12-72					
CHECKED: J. KALAGHOSKI DATE: 5-12-72					
ILLUSTRATOR: R. BERTON DATE: 6-27-72					
PROJ. ENGR: P. FALLO DATE: 10-27-72					
PROD. ENGR: J. ALLEN DATE: 10-27-72					
TITLE: POWER CONTROL 861					
DRAWING NO.: B-DD-861-0-0					
SCALE: 1:1					
SHEET: 1 OF 2					

8 7 6 5 4 3 2 1

THIS DRAWING AND INFORMATION HEREON ARE THE PROPERTY OF GENERAL ELECTRIC COMPANY AND WILL BE LOANED TO YOU FOR THE PURPOSES OF THE PROJECT ONLY. IT IS NOT TO BE REPRODUCED OR TRANSMITTED IN ANY FORM OR BY ANY MEANS, ELECTRONIC OR MECHANICAL, INCLUDING PHOTOCOPYING, RECORDING, OR BY ANY INFORMATION STORAGE AND RETRIEVAL SYSTEM. COPYRIGHT © 1974, GENERAL ELECTRIC COMPANY

ITEM NO	DESCRIPTION	FROM	TO	WITH	REMARKS
	AWG	COLOR	CONN POINT	CONN POINT	
2			RI-1	KI-4	70,61 1. IN
			RI-2	KI-5	70,61 1. IN
73	14	BLU	KI-B3	P4-S1	60 4.5 IN
			KI-B3	P4-S2	60 4.5 IN
			KI-B3	C1-3B	63 3.5 IN
			KI-B3	P5-B2	60 4.5 IN
72		BRN	KI-B2	C1-2B	60 4.5 IN
72		BRN	KI-B2	P6-S1	60 4.5 IN
71		BLK	KI-B1	P6-S2	60 4.5 IN
71		BLK	KI-B1	C1-1B	60 4.5 IN
71		BLK	KI-B1	P3-S1	60 4.5 IN
73	14	BLU	CBI-C2	P1-S1	55 3.5 IN
73	14	BLU	KI-A3	P5-2	23,22 3.75 IN
73	14	BLU	KI-A3	P16-2	23,21 6.5 IN
65	12	BRN	CBI-B2	KI-A2	55 6.75 IN
64	12	BLK	CBI-A2	KI-A1	55 10.5 IN
71	14	BLK	CBI-A2	P2-B1	60 7.5 IN
71		BLK	KI-A1	P15-3	23,22 5.5 IN
72		BRN	KI-A2	KI-4	63 3. IN
72		BRN	P16-1	KI-5	63 7.5 IN
73	14	BLU	P1-S2	P2-S1	60 3. IN
66	12	BLU	CBI-C1	FI-N	55 5.5 IN
9		RED	I1-A	CBI-C1	SEE NOTE 13 58 5.75 IN
9		RED	I2-A	CBI-A1	58 4. IN
9		BLK	I1-B	CBI-C1	58 3.75 IN
64	12	BLK	FI-PHI	LOAD	55 3. IN
9		BLK	I2-B	CBI-B1	58 4.75 IN
65	12	BRN	FI-PH2	LOAD	55 5.25 IN
74	14	ORN	P14-1	T1-1	63 10. IN
74	14	ORN	P14-2	T1-2	63 10. IN
68	12	GRN/YEL	FI-1	LOAD	55 4.5 IN
67	14	GRN/YEL	P17	SOLD G1	57 7.75 IN
2			R2-1	C1-3A	59 1. IN
			R2-2	C1-1A	59 1.25 IN
			R2-3	C1-2A	59 1. IN
26	12	BLK	P9-Y	FI-PHI	LINE 55 15. FT.
		WHT	P9-S	FI-N	LINE 55
		RED	P9-X	FI-PH2	LINE 55
26	12	GRN	P9-G	FI-1	LINE 55 15. FT.

\* STRIP WIRE .38 IN

ITEM NO	DESCRIPTION	FROM	TO	WITH	REMARKS
	AWG	COLOR	CONN POINT	CONN POINT	
5			RI-1	KI-4	70,61 1. IN
			RI-2	KI-5	70,61 1. IN
73	14	BLU	KI-B3	P4-S1	60 4. IN
			KI-B3	P4-S2	60 4. IN
			KI-B3	C1-3B	63 3.5 IN
			KI-B3	P5-S1	60 4.5 IN
72		BRN	KI-B2	P3-S1	60 4.5 IN
72		BRN	KI-B2	P6-S1	60 4.5 IN
			KI-B1	P6-S2	60 4.5 IN
			KI-B1	C1-1B	60 4.5 IN
			KI-B1	P3-S1	60 4.5 IN
72		BRN	KI-B2	P4-S1	60 4.5 IN
			KI-A1	P5-4	23,22 6. IN
			KI-A1	P1-B2	60 10. IN
72		BRN	CBI-A2	KI-A1	55 7.5 IN
73		BLU	CBI-C2	KI-A3	55 5.5 IN
			KI-A3	P16-2	23,21 6. IN
			KI-A3	P15-2	23,22 4. IN
73		BLU	P1-S1	P2-S2	60 3. IN
72	14	BRN	P1-B1	P2-B2	60 4.5 IN
9		BLK	I1-B	CBI-B2	58 4. IN
		BLK	I2-B	CBI-B1	58 4. IN
9		RED	I1-A	CBI-C1	58 5. IN
9		RED	I2-A	CBI-A1	58 5. IN
72	14	BRN	CBI-A1	FI-PHI	LOAD 57 3. IN
74		ORN	P14-1	T1-1	63 10. IN
74		ORN	P14-2	T1-2	63 10. IN
27		GRN/YEL	FI-1	LOAD	57 4.75 IN
67	14	GRN/YEL	P17	SOLD G1	57 7.75 IN
3			R2-1	C1-3A	59 1. IN
			R2-2	C1-1A	59 1. IN
72	14	BRN	P16-1	KI-5	63 7. IN
80		GRN/YEL	P9-G	FI-1	LINE 57 15. FT.
80		BRN	P9-Y	FI-PHI	LINE 57 15. FT.
80	14	BLU	P9-X	FI-N	LINE 57 15. FT.

ITEM NO	DESCRIPTION	FROM	TO	WITH	REMARKS
	AWG	COLOR	CONN POINT	CONN POINT	
8			RI-1	KI-4	70,61 1. IN
			RI-2	KI-5	70,61 1. IN
73	14	BLU	KI-B3	P4-S1	60 4.5 IN
			KI-B3	P4-S2	60 4.5 IN
			KI-B3	C1-3B	63 3.5 IN
			KI-B3	P5-B2	60 4.5 IN
72		BRN	KI-B2	P6-B1	60 4.5 IN
			KI-B2	P5-B2	60 4.5 IN
71		BLK	KI-B1	P4-B1	60 6.0 IN
			KI-B1	P3-B2	60 6.0 IN
78		BLU	P6-S2	P5-S1	60 4.5 IN
73		BLU	P3-S1	P4-S2	60 4.5 IN
72		BRN	KI-B2	C1-3B	63 3.5 IN
71		BLK	KI-B1	C1-2B	63 3.5 IN
71		BLK	KI-B1	C1-1B	63 3.5 IN
72		BRN	CBI-B2	P1-B2	60 9.5 IN
			KI-A2	KI-A2	55 6.75 IN
72		BRN	KI-4	KI-A2	63 3.75 IN
71		BLK	CBI-C2	P1-B1	60 9.0 IN
			KI-A1	KI-A1	55 5.75 IN
71		BLK	KI-A1	P15-3	23,22 5.5 IN
			CBI-A2	P1-S2	60 7.5 IN
73		BLU	CBI-A2	KI-A3	55 6. IN
			P1-S1	P2-S2	60 3.0 IN
73		BLU	P16-2	KI-A3	23,21 6.5 IN
72		BRN	P14-1	KI-5	63 6.75 IN
74		ORN	P14-1	T1-1	63 10. IN
74	14	ORN	P14-2	T1-2	63 10. IN
2			R2-1	C1-3A	59 1. IN
			R2-2	C1-1A	59 1.25 IN
			R2-3	C1-2A	59 1. IN
68	12	GRN/YEL	FI-1	LOAD	55 4.75 IN
67	14	GRN/YEL	P17	SOLDER J1	57 7.75 IN
65	12	BRN	CBI-B1	SEE NOTE 13	55 FI-PHI LOAD
64	12	BLK	CBI-C1	55	FI-PHI LOAD 55 3. IN
9		RED	I1-A	CBI-B1	SEE NOTE 13 57 4.25 IN
9		RED	I2-A	CBI-B1	57 4.75 IN
9		BLK	I1-B	CBI-A1	57 3.00 IN
9		BLK	I2-B	CBI-A1	57 5.75 IN
66	12	BLU	CBI-A1	SEE NOTE 13	55 FI-N LOAD 55 4.5 IN
28		GRN	P9-G	19	FI-1 LINE 55 15. FT.
28		BLK	P9-Y	19	FI-PHI LINE 55 15. FT.
28	12	WHT	P9-X	19	FI-N LINE 55 15. FT.

ITEM NO	DESCRIPTION	FROM	TO	WITH	REMARKS
	AWG	COLOR	CONN POINT	CONN POINT	
2			RI-1	KI-4	70,61 1. IN
			RI-2	KI-5	70,61 1. IN
73	14	BLU	KI-B3	P4-S1	60 5.25 IN
72		BRN	KI-B2	P4-S1	60 4. IN
71		BLK	KI-B1	P4-B1	60 5.25 IN
71		BLK	KI-B1	P5-B2	60 5.25 IN
71		BLK	KI-B1	P4-B1	60 6.25 IN
71		BLK	KI-B1	P3-B2	60 6.25 IN
73		BLU	KI-B3	C1-3B	63 3.5 IN
72		BRN	KI-B2	C1-2B	63 3.5 IN
71		BLK	KI-B1	C1-1B	63 3.5 IN
			KI-1	C1-1A	59 1. IN
			R2-1	C1-3A	59 1. IN
			R2-2	C1-1A	59 1. IN
2			R2-3	C1-2A	59 1.25 IN
73	14	BLU	KI-A3	P15-2	23,22 4.25 IN
			KI-A3	P16-2	23,21 5.75 IN
73		BLU	CBI-A2	KI-A3	60 8. IN
72		BRN	KI-A2	P1-S2	63 3.75 IN
			KI-4	KI-4	63 4.5 IN
72		BRN	KI-5	P1-B2	60 8.25 IN
			KI-5	P16-1	23,21 6.75 IN
71		BLK	KI-A1	P15-3	23,22 6. IN
71		BLK	CBI-C2	P2-B1	60 8. IN
73	14	BLU	P1-S1	P2-S2	60 3. IN
9		BLK	I1-B	CBI-C1	58 4.5 IN
9		RED	I1-A	CBI-B1	58 4.5 IN
9		RED	I2-A	CBI-A1	58 3.5 IN
73	14	BLU	CBI-A1	SEE NOTE 13	57 FI-N LOAD 57 4.5 IN
71		BLK	CBI-C1	57	CBI-B1 57 3. IN
71		BLK	FI-PHI	LOAD	57 6.5 IN
67		GRN/YEL	FI-1	LOAD	57 4.75 IN
67		GRN/YEL	P17	SOLD G1	57 7.75 IN
74		ORN	P14-1	T1-1	63 10. IN
74		ORN	P14-2	T1-2	63 10. IN
73		BLU	P3-S1	P4-S2	60 4.5 IN
73	14	E J	P5-S1	P6-S2	60 4.5 IN
29	14	GRN	P9-G	FI-1	LINE 57 9. FT.
29	14	BLK	P9-Y	FI-PHI	LINE 57 9. FT.
29	12	WHT	P9-X	FI-N	LINE 57 9. FT.

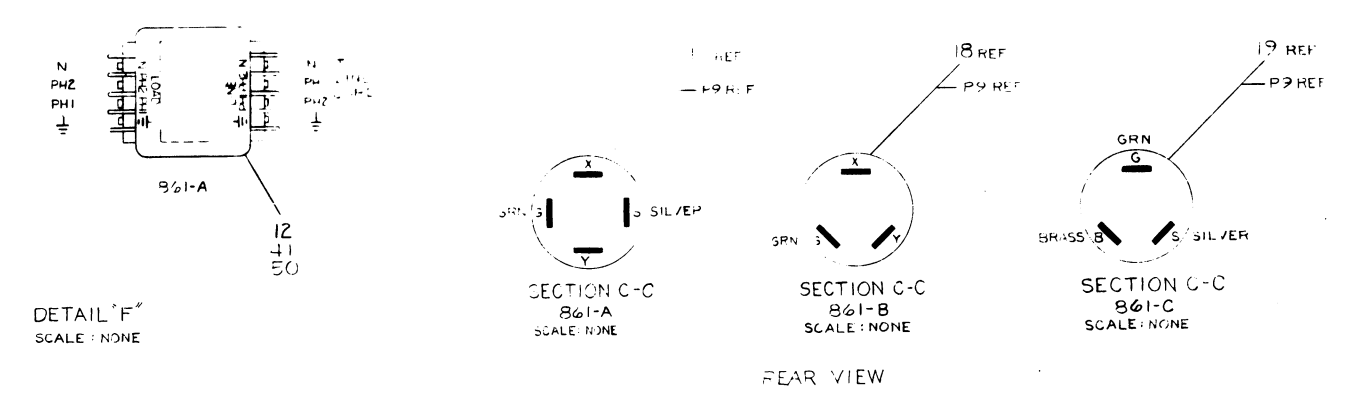

DCS5411522-0-1 2 1

"THIS DRAWING AND SPECIFICATIONS, HEREIN, ARE THE PROPERTY OF DIGITAL EQUIPMENT CORPORATION AND SHALL NOT BE REPRODUCED OR COPIED OR USED IN WHOLE OR IN PART AS THE BASIS FOR THE MANUFACTURE OR SALE OF ITEMS WITHOUT WRITTEN PERMISSION. COPYRIGHT © 1975, DIGITAL EQUIPMENT CORPORATION"

NOTES:

D

C

B

A

D

C

A

B

A

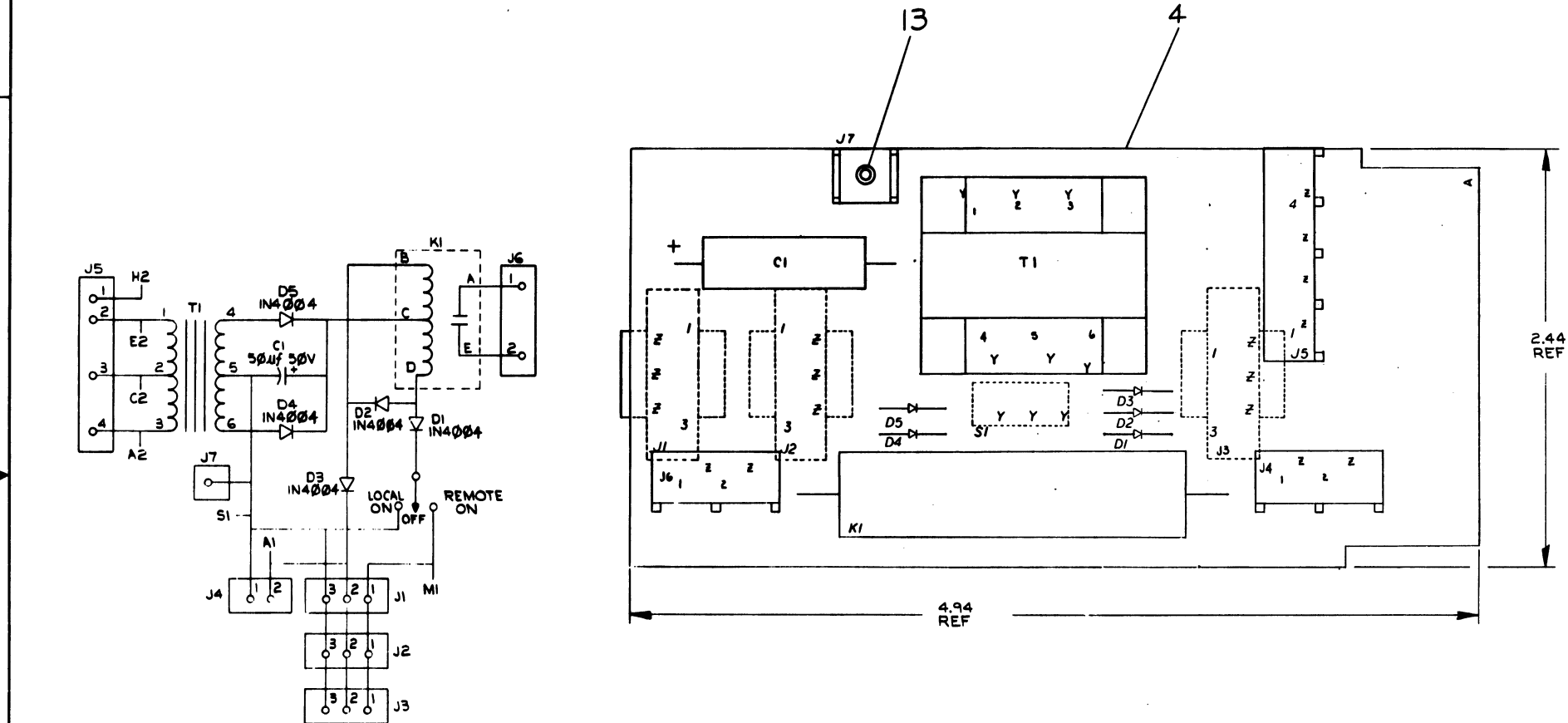

REF	DESCRIPTION	PART NO.	ITEM NO.
	X-Y COORDINATE HOLE LOCATION	K-CO-5411522-0-4	1
	ASSY/DRILLING HOLE LAYOUT	D-AH-5411522-0-5	2
	MODULE ECO HISTORY	B-MM-5411522-0-6	3
	ETCHED CIRCUIT BOARD	5011521	4
1 KI	RELAY, REED, 48V COIL, 2.5A CONT.	1212267-00	5
1 T1	TRANSFORMER MMC 5415	1612342-00	6
1 C.	CAP 50 MFD 50V TANT	1000080-00	7
5 D1-D5	DIODE IN4004	1105796-00	8
1 S1	SWITCH	1211180-00	9
3 J1-J3	HOUSING, SOCKET	1209350-03	10
1 J5	CONN, UNIVERSAL, 4 PIN HEADER	1212297-01	11
2 J4, J6	CONN, UNIVERSAL, 2 PIN HEADER	1212297-00	12
1	EYELET	9006732-00	13
9	TERMINAL, SOCKET CONTACT	1209456-01	14
1 J7	TERMINAL, SOLDERLESS	9007113-00	15

IC TYPE	GND	+5V

GND AND 5V ARE USUALLY PIN 7 AND 14 RESPECTIVELY EXCEPTIONS ARE STATED ABOVE

IC PIN LOCATIONS

FIRST USED ON OPTION MODEL  
861-D / 861-E

CHK	CHANGE NO.	REV	REVISIONS	DATE

DEC NO.	EIA NO.	DEC NO.	EIA NO.

SCALE	SHEET	OF	DIST
NONE	1	1	

DATE	BY	TITLE
2/19/75	K. Hullen	PILOT CONTROL
2/11/75	W. McGee	
2/11/75	John Deane	
2/11/75	John Deane	
2/11/75	John Deane	
2/11/75	John Deane	

digital EQUIPMENT CORPORATION

SIZE CODE NUMBER REV.  
DCS5411522-0-1 A

8

7

6

5

4

3

2

1

DCS5411522-0-1 A

The drawing and specifications, herein, are the property of Digital Equipment Corporation and shall not be reproduced or copied or used in whole or in part, in any form for the manufacture or sale of items without written permission.

NOTE:  
1. R1, R2, + R3 ARE MOV VARISTOR SPIKE SUPPRESSORS.

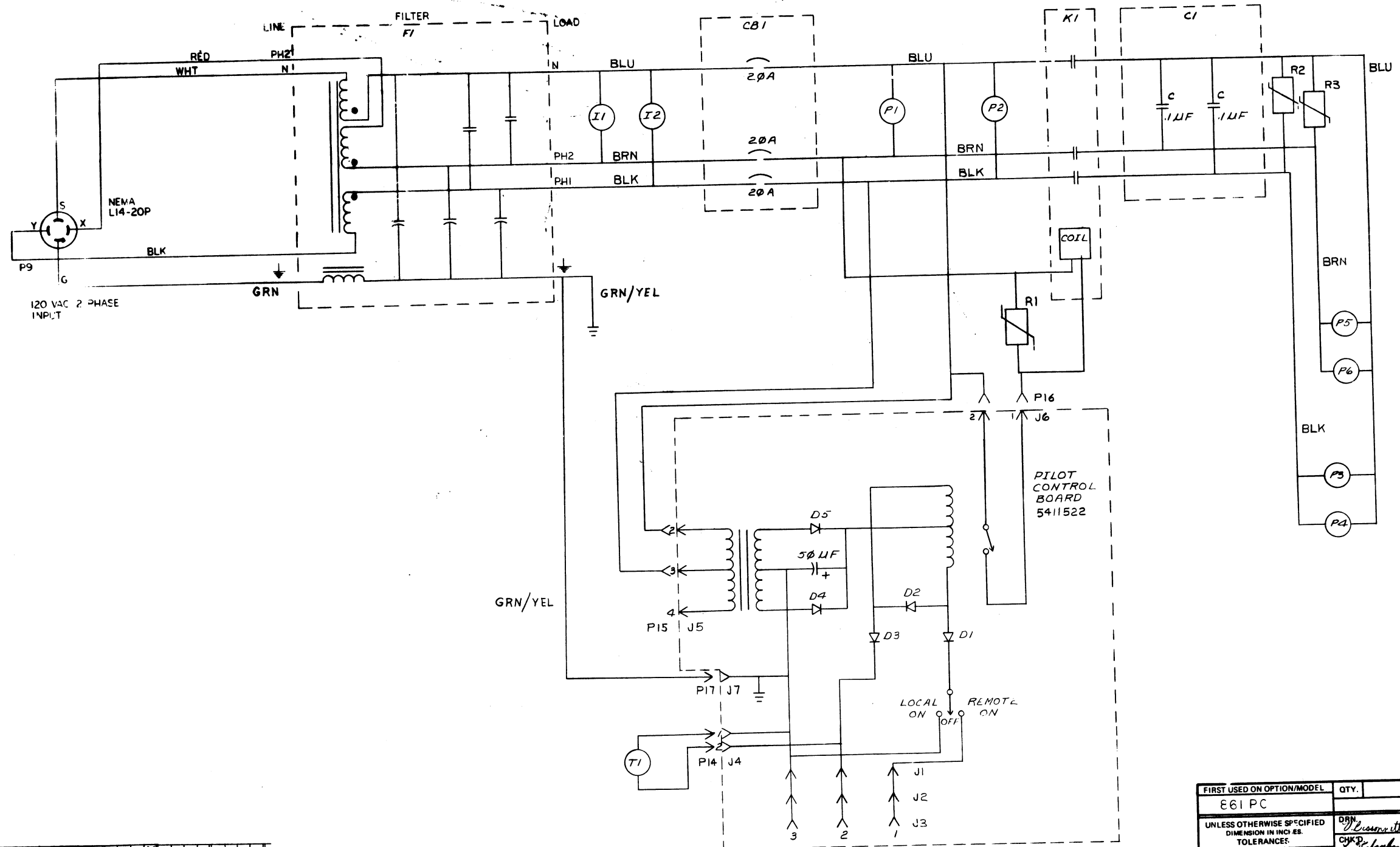

REV	CHANGE NO.	DATE	BY
1	1861-00006	12-20-70	R. Kennedy
2	1861-00009	12-FEB-76	R. Kennedy
3	1861-00010	12-14-76	R. Kennedy
4	1861-00011	1-16-76	S. CARTER
5	1861-00012	1-17-76	S. CARTER
6	1861-00013	2-23-76	R. Kennedy

FIRST USED ON OPTION/MODEL	QTY.	DESCRIPTION	PART NO.	ITEM NO.
861 PC		PARTS LIST		
UNLESS OTHERWISE SPECIFIED DIMENSION IN INCHES.	DRN	DATE	DIGITAL EQUIPMENT CORPORATION	
TOLERANCES:	CHK'D	DATE	MAYNARD MASSACHUSETTS	
DECIMALS	ENG	DATE	TITLE	
XXX - .006	PROJ ENGR	DATE	CIRCUIT SCHEMATIC	
XX - .02	PRD'D	DATE	(861-A-PC)	
X - .1	CORNER SURFACE QUALITY	DATE		
MATERIAL	NEXT HIGHER ASSY.	SCALE	SIZE CODE	NUMBER
FINISH	B-DD-861-0	SHEET	DCS 861-A-1	REV. E

This drawing and specifications herein are the property of Digital Equipment Corporation and shall not be reproduced or copied or used in whole or in part as the basis for the manufacture or sale of items without written permission.

3 1-1-73 2 1

NOTE:  
1. R1-R2 ARE MOV VARISTOR SPIKE SUPPRESSORS.

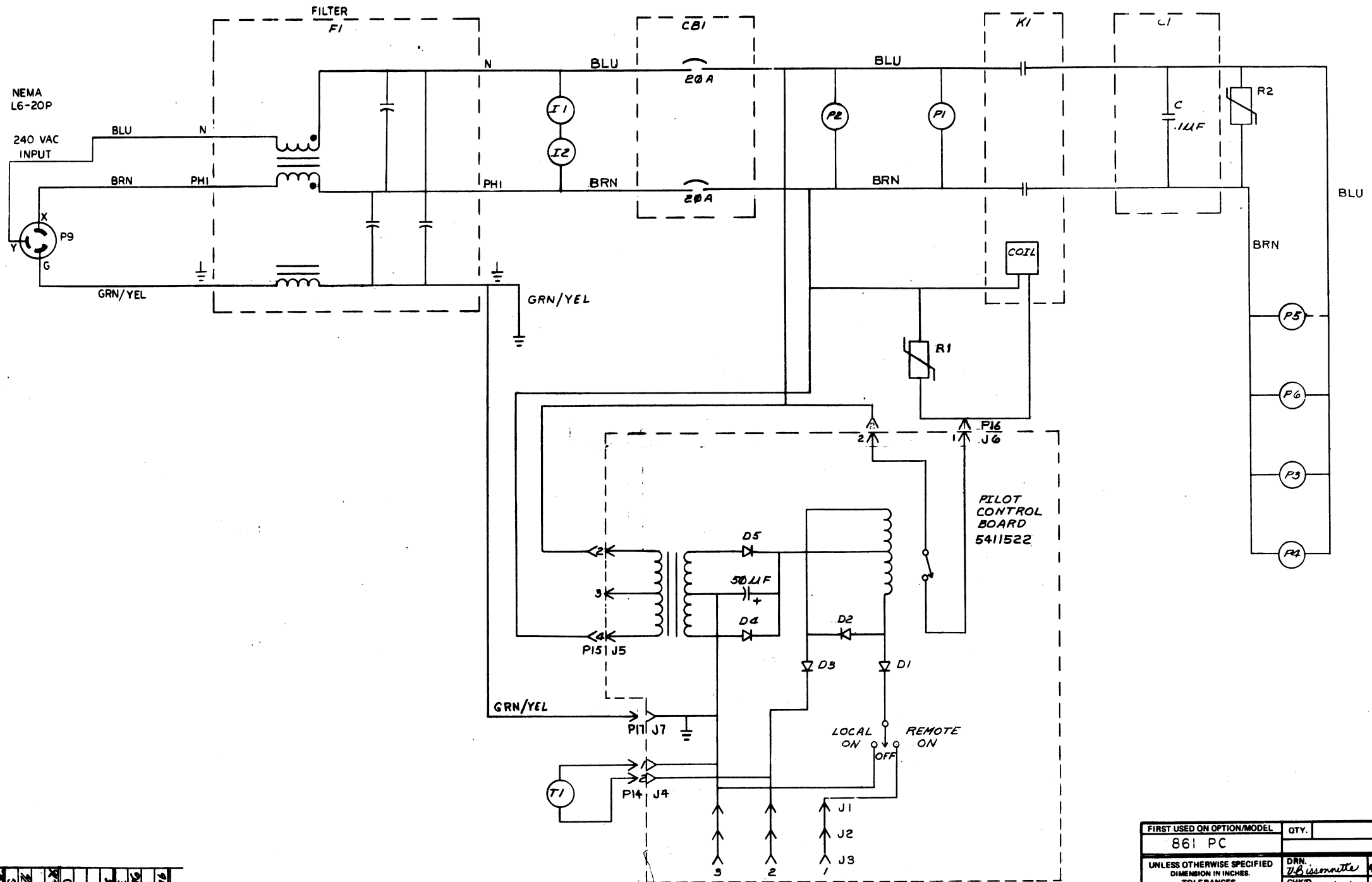

REV.	CHANGE NO.	DATE	BY	CHK'D
1	1	12-7-72	J. O'Connell	J. O'Connell
2	1	12-7-72	J. O'Connell	J. O'Connell
3	1	12-7-72	J. O'Connell	J. O'Connell
4	1	12-7-72	J. O'Connell	J. O'Connell
5	1	12-7-72	J. O'Connell	J. O'Connell
6	1	12-7-72	J. O'Connell	J. O'Connell
7	1	12-7-72	J. O'Connell	J. O'Connell
8	1	12-7-72	J. O'Connell	J. O'Connell
9	1	12-7-72	J. O'Connell	J. O'Connell
10	1	12-7-72	J. O'Connell	J. O'Connell
11	1	12-7-72	J. O'Connell	J. O'Connell
12	1	12-7-72	J. O'Connell	J. O'Connell
13	1	12-7-72	J. O'Connell	J. O'Connell
14	1	12-7-72	J. O'Connell	J. O'Connell
15	1	12-7-72	J. O'Connell	J. O'Connell
16	1	12-7-72	J. O'Connell	J. O'Connell
17	1	12-7-72	J. O'Connell	J. O'Connell
18	1	12-7-72	J. O'Connell	J. O'Connell
19	1	12-7-72	J. O'Connell	J. O'Connell
20	1	12-7-72	J. O'Connell	J. O'Connell

FIRST USED ON OPTION/MODEL	QTY.	DESCRIPTION	PART NO.	ITEM NO.
861 PC				
PARTS LIST				
UNLESS OTHERWISE SPECIFIED DIMENSION IN INCHES	DRN. J.B. Bismonte	DATE 9-11-72	 DIGITAL EQUIPMENT CORPORATION MAYNARD MASSACHUSETTS	
TOLERANCES	CHK'D J. O'Connell	DATE 11-6-72		
DECIMALS	ENG. J. O'Connell	DATE 10-6-72	TITLE <b>CIRCUIT SCHEMATIC (861-B-PC)</b>	
ANGLES	PROT. ENG. J. O'Connell	DATE 12-6-72		
.XXX - .006			NUMBER <b>DCS 861-B-1</b>	
.XX - .02				
.X - .1			REV. <b>E</b>	
REMOVE BURRS AND BREAK SHARP CORNERS SURFACE QUALITY				
MATERIAL	NEXT HIGHER ASSY.		DIST.	
FINISH	B-DD-861-0			
SCALE			SHEET OF	

NOTE:  
 1. R1, R2+R3 ARE MOV VARISTOR SPIKE SUPPRESSORS.

This drawing and specifications, herein, are the property of Digital Equipment Corporation and shall not be reproduced or copied or used in whole or in part as the basis for the manufacture or sale of items without written permission.

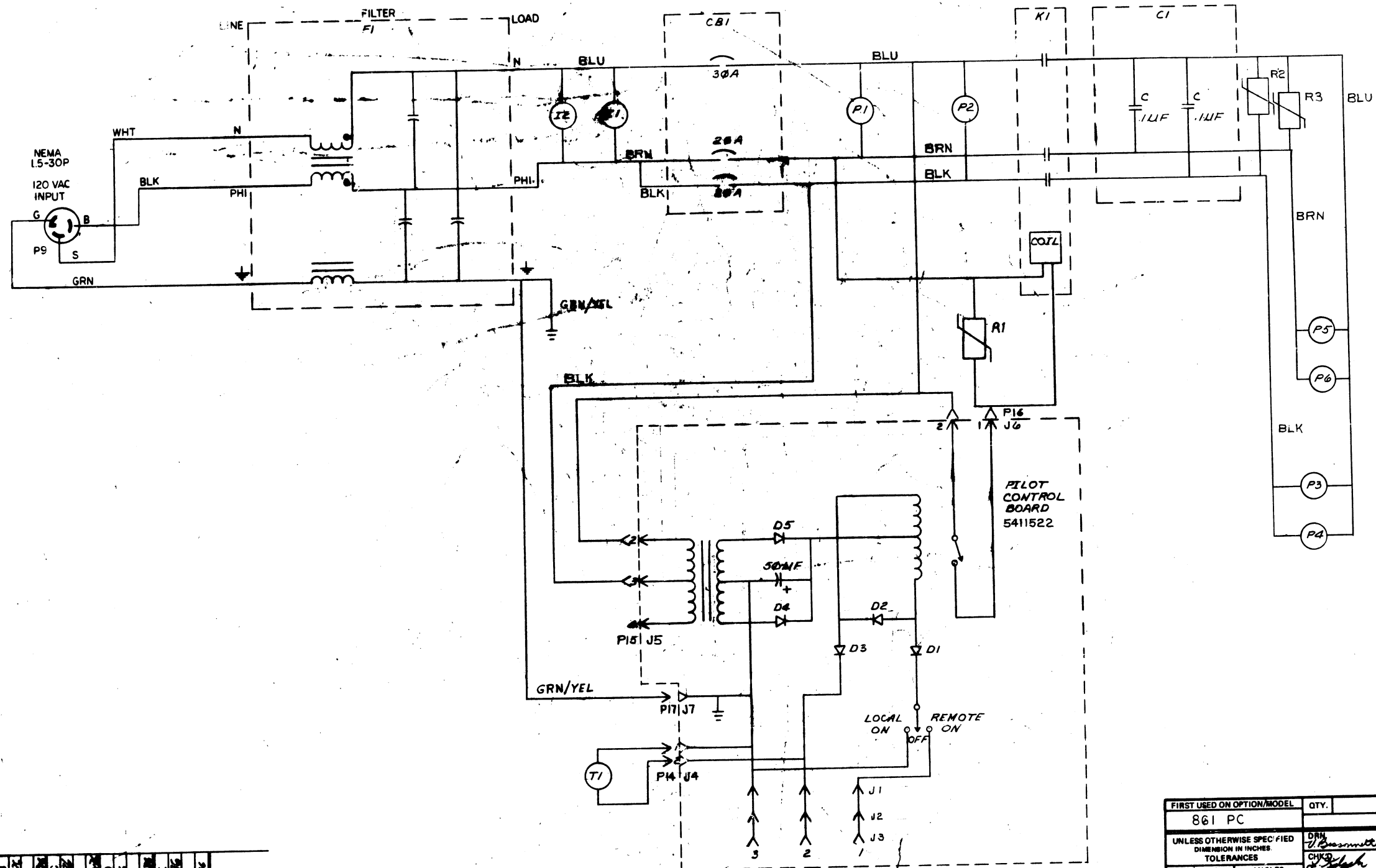

REV.	DATE	BY	CHKD	DATE
1	12-10-72	A		
2	12-10-72	B		
3	12-10-72	C		
4	12-10-72	D		
5	12-10-72	E		
6	12-10-72	F		
7	12-10-72	G		
8	12-10-72	H		
9	12-10-72	I		
10	12-10-72	J		
11	12-10-72	K		
12	12-10-72	L		
13	12-10-72	M		
14	12-10-72	N		
15	12-10-72	O		
16	12-10-72	P		
17	12-10-72	Q		
18	12-10-72	R		
19	12-10-72	S		
20	12-10-72	T		

FIRST USED ON OPTION/MODEL	QTY.	DESCRIPTION	PART NO.	ITEM NO.
861 PC				
PARTS LIST				
DRN	DATE	EQUIPMENT CORPORATION		
CHKD	DATE	WATRAM, MASSACHUSETTS		
ENG	DATE	TITLE		
DES	DATE	CIRCUIT SCHEMATIC		
APP	DATE	861-C P.C.		
REV	DATE			
REMOVE BURRS AND BREAK SHARP CORNERS SURFACE QUALITY				
MATERIAL	NEXT HIGHER ASSY.	SIZE	NUMBER	REV
FINISH	B-DD-861-0	DCS	861-C-1	E
SCALE				
SHEET	OF	DIST.		

This drawing and specifications, herein, are the property of Digital Equipment Corporation and shall not be reproduced or copied or used in whole or in part as the basis for the manufacture or sale of items without written permission.

<b>DIGITAL EQUIPMENT CORPORATION MAYNARD MASSACHUSETTS</b>			
<b>PACKAGING INSTRUCTION</b>		REV: <u>A</u>	DATE: <u>4-73</u>
<b>TITLE</b> 861 POWER CONTROL, INTERPLANT PACKAGE		_____	_____
<b>MATERIAL REQUIREMENTS</b>			
Quantity	Identification No.	Purchase Spec	Description
1	7-2008 1314 0500-0	9905229	Full overlap carton
2		9905228	Expanded polystyrene foam insert
A/R			3-inch wide Glasflex tape
<b>PACKAGING INSTRUCTIONS</b>			
Step	Procedure		
1	Set up the full over lap carton (9905229) using one strip of tape across the bottom and extending up the sides approximately three inches. See Figure 1.		
2	Place one expanded polystyrene foam insert (9905228) in each end of the carton with the slots in the foam facing inward.		
3	Place the 861 power control in the carton with the ears of the upright sliding into the slots in the foam.		
4	Coil the power cord so that it fits into the cavity in the rear of the power control.		
5	Close and seal the carton with one piece of tape across the top of the carton and extending down the sides approximately three inches.		
<b>ENG.</b> <i>[Signature]</i>	DATE: <u>4/13/73</u>	<b>APPD.</b> <i>[Signature]</i>	REV <u>A</u>
SIZE <u>A</u>	CODE <u>PI</u>	NUMBER <u>3700083-0-0</u>	REV <u>A</u>

DEC 8-(551)-1031-1-R671  
DRA - 129

This drawing or specifications, herein, are the property of Digital Equipment Corporation and shall not be reproduced or copied or used in whole or in part as the basis for the manufacture or sale of items without written permission.

<b>PACKAGING INSTRUCTION</b>		REV: <u>A</u>	DATE: <u>4/73</u>
<b>TITLE</b> 861 POWER CONTROL, INTERPLANT PACKAGE		_____	_____
<b>FIGURE 1</b>			
<p><b>NOTE</b> Make changes to the "C" size original only and rephotograph.</p>			
<b>ENG.</b> <i>[Signature]</i>	DATE: <u>12/1/72</u>	<b>APPD.</b> <i>[Signature]</i>	REV <u>A</u>
SIZE <u>A</u>	CODE <u>PI</u>	NUMBER <u>3700083-0-0</u>	REV <u>A</u>

DRC-107

"THIS DRAWING AND SPECIFICATIONS, HEREIN, ARE THE PROPERTY OF DIGITAL EQUIPMENT CORPORATION AND SHALL NOT BE REPRODUCED OR COPIED OR USED IN WHOLE OR IN PART AS THE BASIS FOR THE MANUFACTURE OR SALE OF ITEMS WITHOUT WRITTEN PERMISSION. COPYRIGHT © 1974, DIGITAL EQUIPMENT CORPORATION"

NOTE :  
1 R1 R2 + R3 ARE MOV VARISTOR SPIKE SURPRESSORS.

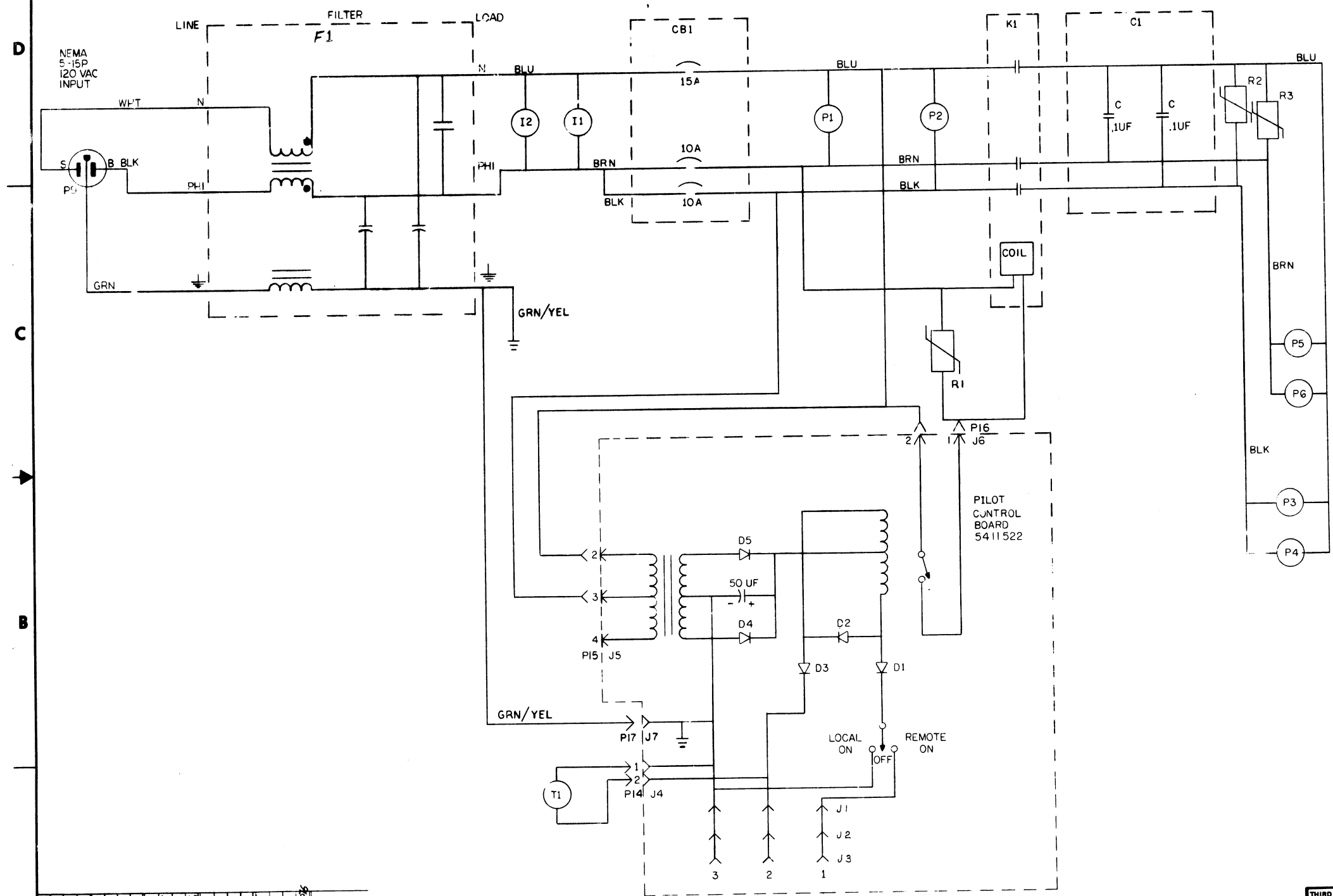

REV.	CHANGE NO.	BY	DATE
1	861-00007	R. KENNEDY	12-15-76
2	861-00009	R. KENNEDY	12-15-76
3	861-00010	R. KENNEDY	12-15-76
4	861-00011	R. KENNEDY	12-15-76
5	861-00012	S. CARTER	16 Aug 76
6	861-00013	S. CARTER	16 Aug 76
7	861-00014	S. CARTER	16 Aug 76
8	861-00015	S. CARTER	16 Aug 76

DESCRIPTION		DWG./PART NO.	ITEM NO.
UNLESS OTHERWISE SPECIFIED DIMENSIONS ARE IN INCHES			
ANGLES 30° 30'	CLASS OF ACCURACY	NOMINAL DIMENSION RANGE INCHES	
SURFACE QUALITY IN	(CHECK ONE)	OVER 0 TO 0.3	OVER 0.3 TO 0.5
		OVER 0.5 TO 1.2	OVER 1.2 TO 3.0
QUANTITY & VARIATION	MICROINCHES	MEDIUM	PREFERRED
		±.004	±.008
THIRD ANGLE PROJECTION		FIRST USED ON	861 P.C.
REMOVE BURR AND BREAK SHARP CORNERS		TITLE	CIRCUIT SCHEMATIC 861-F P.C.
DO NOT SCALE DWG		SIZE	D CS
MATERIAL		SCALE	NUMBER
FINISH		SHEET	DIST.

861-F-1 DCS B D



digital

EQUIPMENT CORPORATION  
MAYNARD, MASSACHUSETTS

# DRAWING DIRECTORY

"THIS DRAWING AND SPECIFICATIONS, HEREIN, ARE THE PROPERTY OF DIGITAL EQUIPMENT CORPORATION AND SHALL NOT BE REPRODUCED OR COPIED OR USED IN WHOLE OR IN PART AS THE BASIS FOR THE MANUFACTURE OR SALE OF ITEMS WITHOUT WRITTEN PERMISSION. COPYRIGHT © 1975 . DIGITAL EQUIPMENT CORPORATION"

## CUSTOMER PRINT SET INDEX

THIS IS PRINT SET 

--	--	--	--

SEQUENCE



SEQUENCE



DRAWING DIRECTORY  
WIRING DIAGRAM  
POWER LINE MONITOR  
H7420 POWER SUPPLY  
H7420 POWER SUPPLY (P.L.)

B-DD-H7420-0  
D-CS-H7420-0-0  
D-CS-5411086-0-1  
E-UA-H7420-0-0  
A-PL-H7420-0-0

### UNIT VARIATIONS

UNIT VARIATIONS		PRINT SET			
VAR	TITLE	1			
H7420A	H7420 POWER SUPPLY (120V)				
H7420B	H7420 POWER SUPPLY (240V)				

REVISIONS		REV
DATE	CHG. NO.	
6-75	H7420-1	A
7-75	H7420-2	B
3-76	H7420-3	C
4-76	H7420-4	D
9-76	H7420-5	E

USED ON OPTION/MODEL	DRN.	DATE	TITLE	SIZE	CODE	NUMBER	REV
	R. E. Thellen	1/29/75	H7420 POWER SUPPLY	B	DD	H7420-0	E
	CHK'D.	DATE					
	<i>R. Capponi</i>	2/3/75					
	PROJ. ENG.	DATE					
	<i>R. D. 104</i>	2/5/75					
	PROD.	DATE					
	<i>Boerstein</i>	2/3/75					
	FIELD SERV.	DATE					
	<i>W. ...</i>	2-19-75					
SHEET	1	OF	3	DIST			

DEC 16 (3251-1062-1A-R972)



# DRAWING DIRECTORY

THIS IS PRINT SET

## CUSTOMER PRINT SET INDEX

DRAWING DIRECTORY  
CIRCUIT SCHEMATIC  
PWR CONTROL BOARD  
CIRCUIT SCHEMATIC  
UNIT ASSEMBLY H742  
UNIT ASSEMBLY (PL)

SEQUENCE

B-DD-H742- $\beta$   
D-CS H742- $\beta$ -1  
E-1A 5409730-0-0  
C-CS 5409730-0-1  
E-UA-H742- $\beta$ - $\beta$   
A-PL-H742- $\beta$ - $\beta$

SEQUENCE

MFG SET  
TEST PROCEDURE A-SP H742  $\beta$ -3  
MFG SPEC. A-SP-H742- $\beta$ -8  
PACKAGING INSTRUCTION A-PI-3700073-0-0

UNIT VARIATIONS		PRINT SET TYPE			
VARIATION	TITLE	H742-1			
H742-A	CHASSIS ASSY (115V)	X			
H742-B	CHASSIS ASSY (230V)	X			
H742-C	CHASSIS ASSY (115V)	X			
H742-D	CHASSIS ASSY (230V)	X			

REVISONS	CHG. NO.		DATE	USED ON OPTION/MODEL	DRN. J. FONTAINE	DATE 13172	TITLE CHASSIS ASSY H742	REV Y.
	REV	NO.						
	A	H742-2	7/72	11/45	CHK'D	2-4-72		
	B	H742-3	7/72		PROJ ENG.	2-4-72		
	C	H742-4	6/72		PROD.	2-24-72		
	D	H742-5	8/72		FIELD SERV.	2-9-72		
	E	H742-7	10/72		SHEET	1 OF 3		
	F	H742-8	11/72		SIZE	B DD		
	H	H742-11	12/72		CODE			
	J	H742-12	2/73		NUMBER	H742- $\beta$		
	K	H742-13	2/73		DIST			
	L	H742-14	2-73					
	M	H742-15	4-73					
	N	H742-16	4-73					
	P	H742-17	5-73					
	R	H742-18	6-73					
	S	H742-19	12-73					
	T	H742-20	3-74					
	U	H742-21	4-74					
	V	H742-22	5-75					
	W	H742-23	9-75					
	Y	H742-24	4-76					

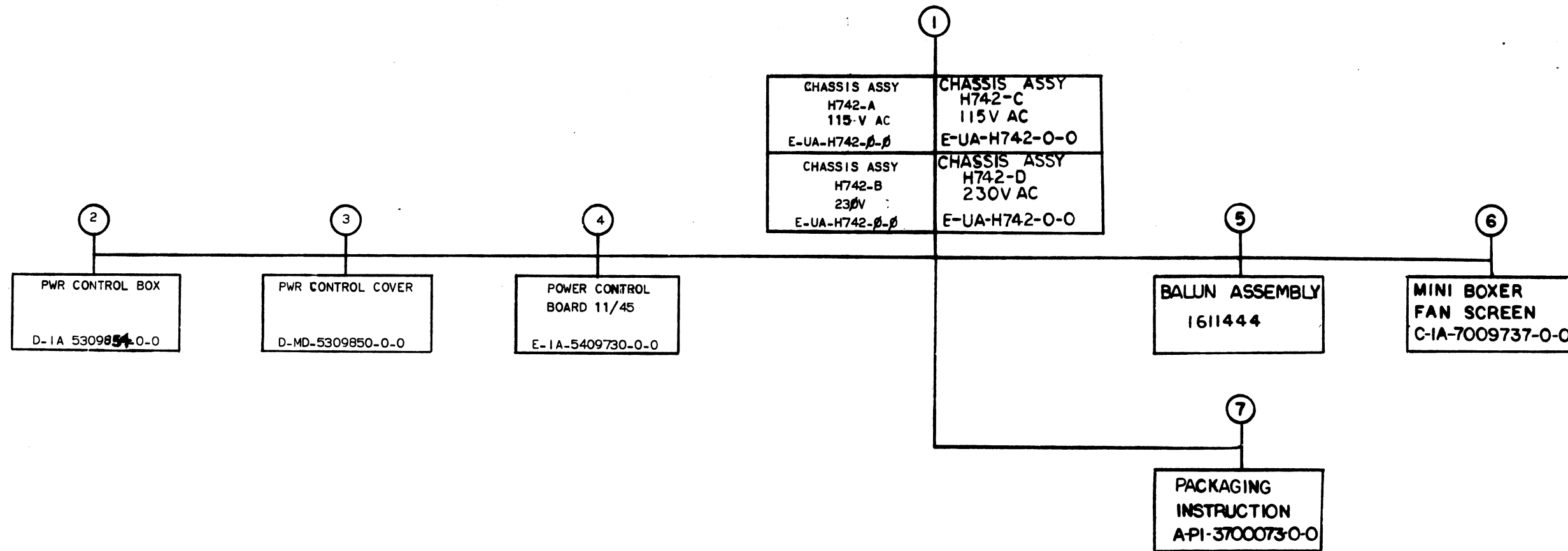

TITLE	SHEET	SIZE	CODE	NUMBER	REV
CHASSIS ASSY H742	2 OF 3	B	DD	H742- $\beta$	Y

CUSTOMER PRINT SET		ELECTRICAL					CUSTOMER PRINT SET		MECHANICAL				
		FIND NO.	REV	NO OF SHTS	DESCRIPTION	OPTION NO./FILE DATE	H742-1		FIND NO.	REV	NO OF SHTS	DESCRIPTION	OPTION NO./FILE DATE
X		1		F 1	CIRCUIT SCHEMATIC	H742	X		1	E-UA-H742-Ø-Ø	Y 3	CHASSIS ALLY H742	H742
X					TEST PROCUDERE	H742	X			A-PL-H742-Ø-Ø	Y 4	CHASSIS ASSY H742	H742
X					MFG SPECIFICATION	H742				E-IA-5309755-0-0	3	CHASSIS H742	H742
										D-IA-7409701-0-0	1	BRACKET, POWER SUPPLY	H742
										C-MD-7409702-0-0	1	COVER POWER SUPPLY	H742
										A-DC-5310459-0-0	1	DECAL, H742A	H742
										A-DC-5310460-0-0	1	DECAL, H742B	H742
										A-DC-5310461-0-0	1	DECAL, H742C	H742
										A-DC-5310462-0-0	1	DECAL, H742D	H742
									2	D-IA-5309854-0-0	1	POWER CONTROL BOX	H742
										A-SS-5309854-0-1	1	SILK SCREEN (H742)	H742
X		4		# 1	CIRCUIT SCHEMATIC	H742							
							X						
									3	D-MD-5309850-0-0	1	POWER CONTROL COVER	H742
										A-SS-5309850-0-1	1	SILK SCREEN	H742
									4	E-IA-5409730-0-0	# 1	PWR CONTROL BD ASSY	H742
										5009729-0-0	# 1	PWR CONTROL BD	H742
									5	1611444	1	BALUN ASSEMBLY	H742
									6	C-IA-7009737-0-0	1	MINI BOXER FAN SCREEN	
										B-MD-7411625-0-0	1	FAN SCREEN	
										B-MD-7411627-0-0	1	FAN PLATE	
									X 7	A-PI-3700073-0-0	# 2	PACKAGING INSTRUCTION	
										A-PS-9905205-0-0	2	REGULAR SLOTTED CARTON	
										A-PS-9905206-0-0	2	DIE-CUT SHEET	
										A-PS-9905207-0-0	2	LAMINATED BASE	

CUSTOMER PRINT SET CODES	X = PRINT OF DOCUMENT INCLUDED IN PRINT SET	TITLE	SIZE	CODE	NUMBER	REV
	C = INCLUDES ALL PRINTS INDICATED ON DOCUMENT	CHASSIS ASSY H742	B	DD	H742-Ø	Y
	S = CONFIDENTIAL AUTHORIZED SIGNATURE REQUIRED	SHEET 3 OF 3				



"THE MATERIAL HEREIN IS FOR INFORMATION PURPOSES ONLY AND IS SUBJECT TO CHANGE WITHOUT NOTICE. DIGITAL EQUIPMENT CORPORATION ASSUMES NO RESPONSIBILITY FOR ANY ERRORS WHICH MAY APPEAR HEREIN."

# DRAWING DIRECTORY

"THIS DRAWING AND SPECIFICATIONS, HEREIN, ARE THE PROPERTY OF DIGITAL EQUIPMENT CORPORATION AND SHALL NOT BE REPRODUCED OR COPIED OR USED IN WHOLE OR IN PART AS THE BASIS FOR THE MANUFACTURE OR SALE OF ITEMS WITHOUT WRITTEN PERMISSION. COPYRIGHT © 1972 DIGITAL EQUIPMENT CORPORATION."

## CUSTOMER PRINT SET

DRAWING DIRECTORY	B-DD-H744-0
CIRCUIT SCHEMATIC	D-CS-H744-0-1
UNIT ASSY	E-UA-H744-0-0

## MFG SET

TEST PROCEDURE	A-SP-H744-0-3
MFG SPEC	A-SP-H744-0-8
PACKAGING INST	A-PI-3700074-0-0

## UNIT VARIATIONS

VAR	TITLE
H744	+5V REGULATOR

EN-01003-1A-10-R072-1280

REVISIONS	REV.	R
	CHANGE NO.	00019
CHK	G.P.	

USED ON OPTION/MODEL	DRN.	DATE	TITLE	digital		
11/45	D. FONTAINE	2-4-72				
	CHK'D.	DATE				
	D. FONTAINE	2-4-72				
	PROJ. ENG.	DATE	+5V REGULATOR			
	G. POTTER	2-24-72				
	PROD.	DATE	SIZE	CODE	NUMBER	REV
	A. HIRSCH	2-24-72	B	DD	H744-0	R
SHEET	1	OF	4	DIST.		

This drawing and specifications herein are the property of Digital Equipment Corporation and shall not be reproduced or copied or used in whole or in part as the basis for the manufacture or sale of items without written permission. © 1975 DIGITAL EQUIPMENT CORP.

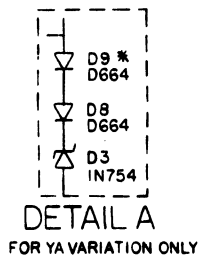
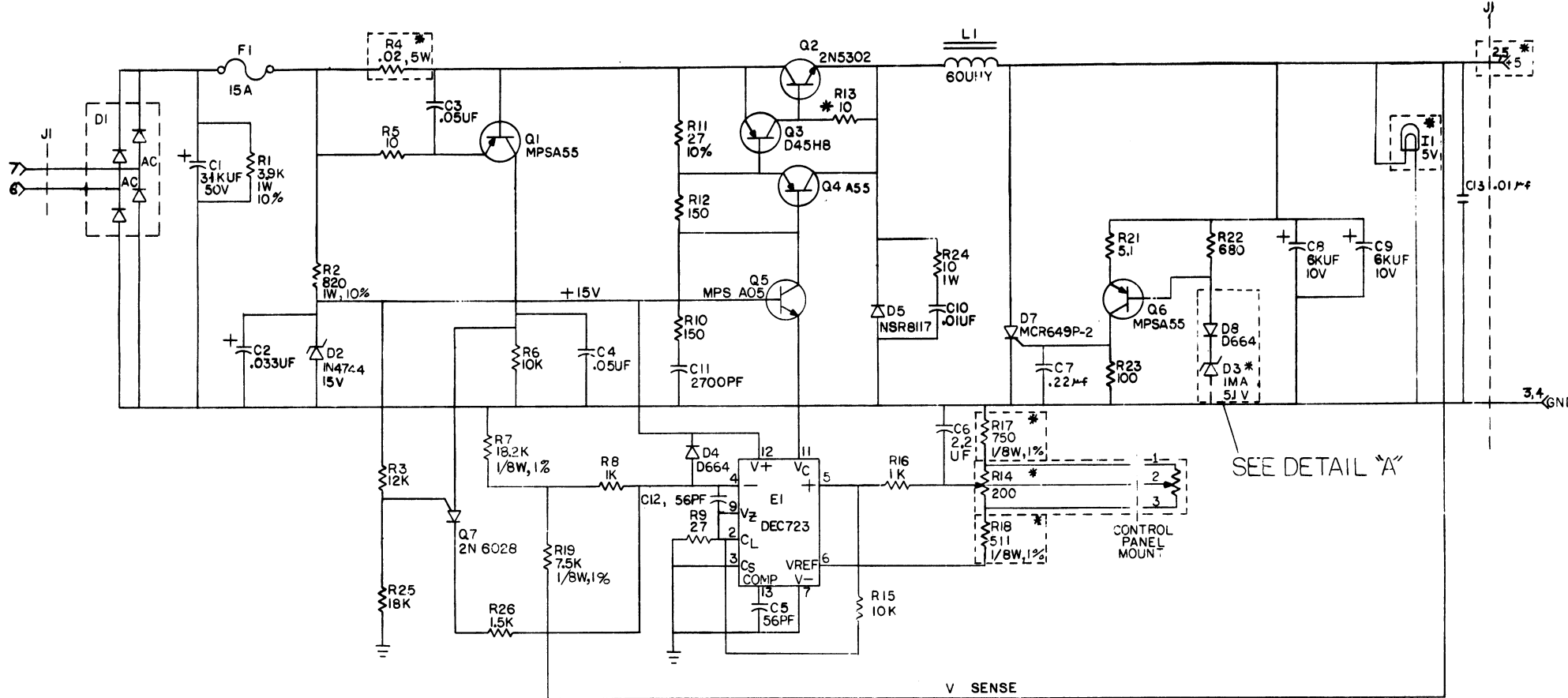

\* FUSIBLE RESISTOR

[\*] FOR YA VARIATION COMPONENT VALUES ARE AS FOLLOWS:  
R4 - .06 5W  
R14 - 1K 10 TURN  
R7 - 300 1/8W 1%  
R19 - 150 1/4W 5%  
D3 - IN754  
I1 - 15V  
J1-2,5 - +20-80V

\* D9 - D664 ADDED FOR YA VARIATION ONLY

UNLESS OTHERWISE INDICATED:  
RESISTORS ARE 1/4W, 5%

QTY	REF DESIGNATION	DESCRIPTION	PART NO.	ITEM NO.
	PARTS LIST			
	ETCH BOARD REV	F H		
1	IN964A	SAME	MPSA55	
1	D054	IN3605	2N5302	
1	H744-0-2	SAME	D45H5	
1	H744	SAME	MPSA55	
1	IN4744			
1	NSR8117			
1	2N6028			
	DEC NO.	EIA NO.	DEC NO.	EIA NO.

DRN	Fogarty	DATE	11-2-71
CHK'D	NICKIE	DATE	1-2-72
ENG	J. J. Jones	DATE	11/2/72
PROJ. ENG.	J. J. Jones	DATE	11/2/72
PROJ. MGR.	J. J. Jones	DATE	11/2/72

SEMICONDUCTOR CONVERSION CHART	
SCALE	DIST.

SIZE CODE	NUMBER	REV.
DCS	H744-0-1	TY

**5V REGULATOR**

DIGITAL EQUIPMENT CORPORATION  
MAYNARD, MASSACHUSETTS

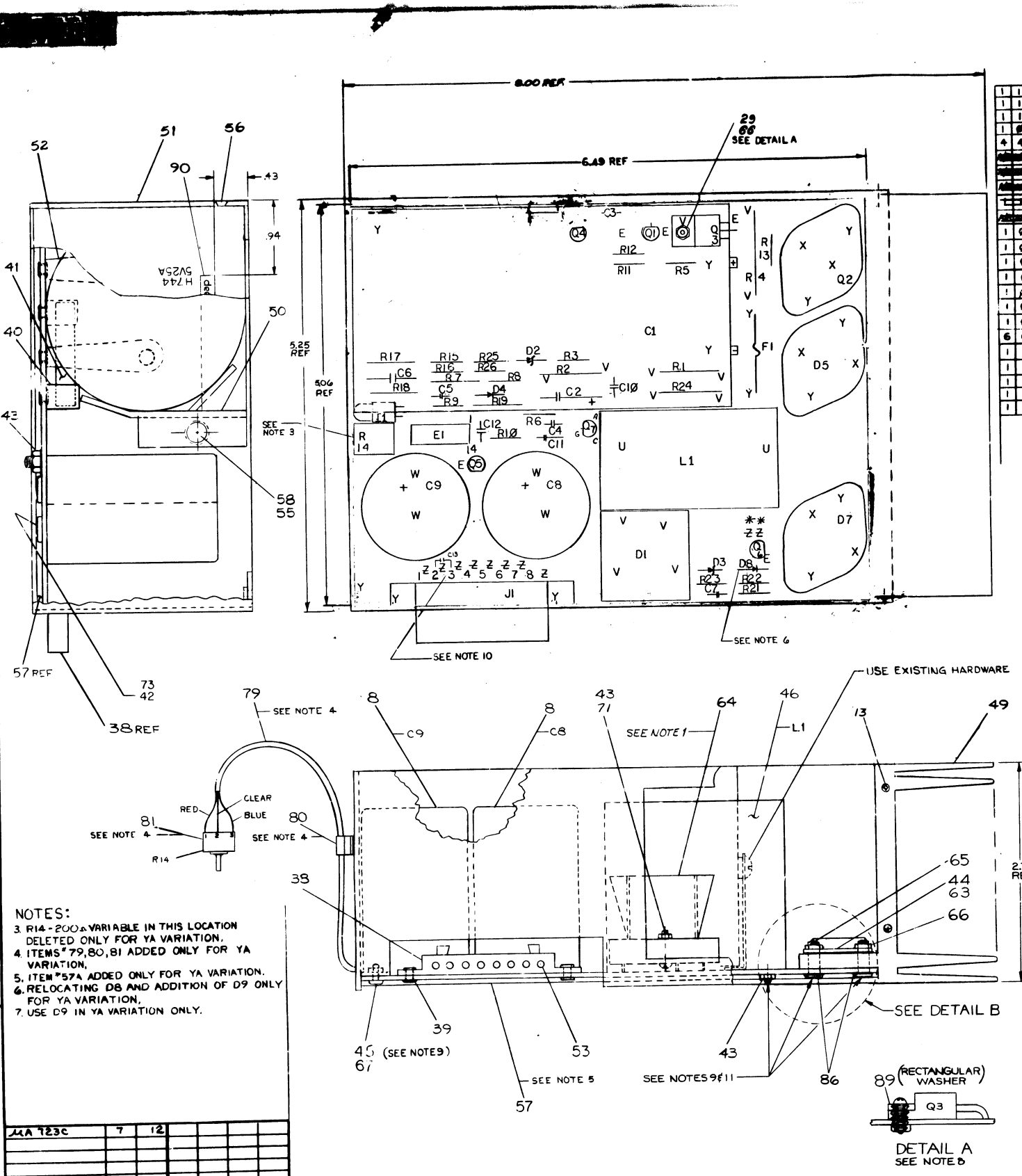

ITEM #	DESCRIPTION	QTY	UNIT	REF	DESCRIPTION	QTY	UNIT	REF
1	RES 680 1/4W 5%	1201426		1	SCR, PHL PAN HD *4-40 1/4 LG	2		1
1	PACKING INSTRUCTIONS	API 570076-04		2	SCR, PHL PAN HD *4-40 3/16 LG	2		2
1	SCR, PHL PAN HD *4-40 1/4 LG	9006082-1		3	SCR, PHL PAN HD *4-40 3/16 LG	2		3
1	16 VOLT LAMP	1201109		4	HEAT SINK BRIDGE	1		4
4	LOCK WASHER #10 INT	9006685		5	COMPOUND THERMAL JOINT	9006888		5
				6	RESISTOR 1-8K 1/4W 5%	1300551		6
				7	RESISTOR 7-8K 1/8W 1%	1305322		7
				8	RESISTOR 18K 1/4W 5%	1300488		8
				9	TRANSISTOR, UNJUNCTION NUMBER	1510877		9
				10	SCR, PHL PAN HD *6-32 X 1/4 LG	9006020-1		10
1	WIRE, MICRODOT	1700014		11	COVER	9006020-2		11
1	CLAMP, CABLE	9007079		12	SCR, PHL FLT HD *6-32 X 3/16 LG	9006020-2		12
1	POT, 10 TURN, 1K	1309532-04		13	WASHER, LOCK #6	9006633		13
1	RES, 300K 1/4W 5%	1301425		14	SCR, PHL FLT HD *6-32 X 1/4 LG	9006020-2		14
1	RES, 180K 1/4W 5%	1300280		15	CONTACT FEMALE	1209456		15
1	RES, 6K 5W 3%	1310876-02		16	STRAP, CAPACITOR	CMD-5309790452		16
1	DIODE ZENER INT754	1109991		17	BRACKET, REGULATOR	DIA-5309796-01		17
6	WASHER, INT TOOTH #4	9006632		18	HOLDER, CAPACITOR 2.5	C-1A-12388-00		18
1	CAP .22UF 50V	1010274		19	HEAT SINK REGULATOR	D-PS-1210737-00		19
1	RES 10 1/4W 5% FUSIBLE	1312496		20	CAP 56 PF	1000012		20
1	WASHER, RECTANGULAR	9009769		21	RESISTOR 10 1W	1300171		21
1	DECAL (H744)	ADC161645-109C		22	REACTOR 60ALHY MMC4347	1610850		22
1	JUMPER	1214074		23	SCR, PHL PAN HD *4-40 1/4 LG	9006020-1		23
				24	WASHER, INSULATOR	9006721		24
				25	NUT, KEPS #6-32	9006185		25
				26	SCR #10-32 X 3/16 SLOTTED PAN HD	9006689-01		26
				27	FUSE 15 AMP	1213237-01		27
				28	FUSE CLIP	9007203		28
				29	EYELET 6S-4-5	9004000		29
				30	MATE-N-LOCK CONN, 6 PIN	1209340		30
				31	INTEGRATED CIRCUIT DEC 723C	1910415		31
				32	TRANSISTOR AD5	1510705		32
				33	TRANSISTOR D4SH8	1510708-1		33
				34	TRANSISTOR MP555MOT	1510706		34
				35	TRANSISTOR 2NE302	1510196		35
				36	RES VARIABLE 200	1310252		36
				37	RES 5.1 1/4W 5%	1309422		37
				38	RES 100 1/4W 5%	1300227		38
				39	SCR, PPH #4-40 X 1/8	9006011		39
				40	RES 27 1/4W 10%	1301420		40
				41	RES 750 1/8W 1%	1302955		41
				42	RES 27 1/4W 5%	1301522		42
				43	RES 18.2K 1/8W 1%	1309412		43
				44	RES 1K 1/4W 5%	1300305		44
				45	RES 511 1/8W 1%	1302411		45
				46	RES 18K 1/4W 5%	1302465		46
				47	RES 10K 1/4W 5%	1300479		47
				48	RES .02 5W 3%	1310276		48
				49	RES 820 1W 10%	1300358		49
				50	RES 3.9K 1W 10%	1302927		50
				51	RES 10 1/4W 5%	1301317		51
				52	RES 150 1/4W 5%	1300250		52
				53	DIODE ZENER 1MA, 51V	1110925		53
				54	SCR MCR 6A9P-2	1109405		54
				55	SCR, PHL #4 X 3/16 1/8 S&L TYP	9009412		55
				56	DIODE PWR NSK B117	1110715		56
				57	DIODE PWR D664	1100114		57
				58	DIODE ZENER IN4744	1105648		58
				59	DIODE BRIDGE	1110714		59
				60	CAP 6K4F 10V	100706		60
				61	CAP 31K4F 50V	1010858		61
				62	CAPABLE 85V	1001774		62
				63	CAP .033UF 100V 10%	1000050		63
				64	CAP 2700PF 100V 5% DM	1001057		64
				65	CAP .01UF 100V 20% DISC	1001010		65
				66	CAP 2.2UF, 20V, 10%	1002627		66
				67	ETCHED CIRCUIT BOARD	5009725		67
				68	A/SY/DRILLING HOLE LAYOUT	D-AH-NPM-8-5		68
				69	X-Y COORDINATE HOLE LOCATION	X-CO-HPM4-8-4		69
				70	MODULE ECO HISTORY	D-MH-HT44-8-4		70
				71	CIRCUIT SCHEMATIC	985HT44-8-4		71

NOTES CONT:

NOTE 8:  
 (1) Q3 SCREW HEAD SHOULD BE ON TOP OF  
 FLAT RECTANGULAR WASHER AS SHOWN.  
 APPLY 1/2 INCH LBS. OF TORQUE WHEN  
 SECURING Q3 TO CXT. BOARD BEFORE  
 SOLDERING.

NOTE 9: TORQUE APPLICATION  
 (1) APPLY 12 INCH LBS. OF TORQUE TO THE  
 SCREWHEAD OF #4 HARDWARE EXCEPT Q3.  
 (2) APPLY 12 INCH LBS. OF TORQUE TO #6  
 HARDWARE ON L1.  
 (3) APPLY 16 INCH LBS. OF TORQUE TO  
 ALL #6 AND #10 HARDWARE EXCEPT  
 ON L1.  
 (4) ALL HARDWARE TO BE TORQUED  
 BEFORE SOLDERING.

NOTE 10:  
 INSERT C13 INTO ETCH PAD HOLES  
 CONNECTED TO J1 TERMINALS, 2-3.

NOTE 11:  
 MIN TORQUE REQUIRED FOR  
 QC INSPECTION:  
 8 INCH LBS. FOR #4 HARDWARE;  
 12 INCH LBS. FOR #6 AND #10 HARDWARE.  
 \*SEE NOTE 7

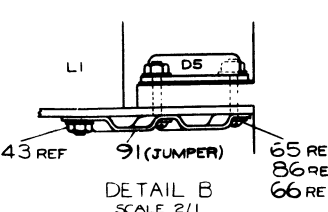

- 3. R14-200 is VARIABLE IN THIS LOCATION  
 DELETED ONLY FOR YA VARIATION.
- 4. ITEMS \*79, 80, 81 ADDED ONLY FOR YA  
 VARIATION.
- 5. ITEM \*57A ADDED ONLY FOR YA VARIATION.
- 6. RELOCATING D8 AND ADDITION OF D9 ONLY  
 FOR YA VARIATION.
- 7. USE D9 IN YA VARIATION ONLY.

AA	7	12				
IC TYPE	QND	QSD				
QND	QSD					

ITEM #	DESCRIPTION	QTY	UNIT	REF
1	RES 680 1/4W 5%	1201426		1
2	SCR, PHL PAN HD *4-40 1/4 LG	9006082-1		2
3	SCR, PHL PAN HD *4-40 3/16 LG	9006020-1		3
4	16 VOLT LAMP	1201109		4
5	LOCK WASHER #10 INT	9006685		5
6	RESISTOR 1-8K 1/4W 5%	1300551		6
7	RESISTOR 7-8K 1/8W 1%	1305322		7
8	RESISTOR 18K 1/4W 5%	1300488		8
9	TRANSISTOR, UNJUNCTION NUMBER	1510877		9
10	SCR, PHL PAN HD *6-32 X 1/4 LG	9006020-1		10
11	WIRE, MICRODOT	1700014		11
12	CLAMP, CABLE	9007079		12
13	POT, 10 TURN, 1K	1309532-04		13
14	RES, 300K 1/4W 5%	1301425		14
15	RES, 180K 1/4W 5%	1300280		15
16	RES, 6K 5W 3%	1310876-02		16
17	DIODE ZENER INT754	1109991		17
18	WASHER, INT TOOTH #4	9006632		18
19	CAP .22UF 50V	1010274		19
20	RES 10 1/4W 5% FUSIBLE	1312496		20
21	WASHER, RECTANGULAR	9009769		21
22	DECAL (H744)	ADC161645-109C		22
23	JUMPER	1214074		23

5V REGULATOR





This drawing and specifications herein are the property of Digital Equipment Corporation and shall not be reproduced, stored in a retrieval system, or transmitted in any form or by any means, electronic, mechanical, photocopying, recording, or by any information storage and retrieval system, without the prior written permission of Digital Equipment Corporation. COPYRIGHT © 1976.

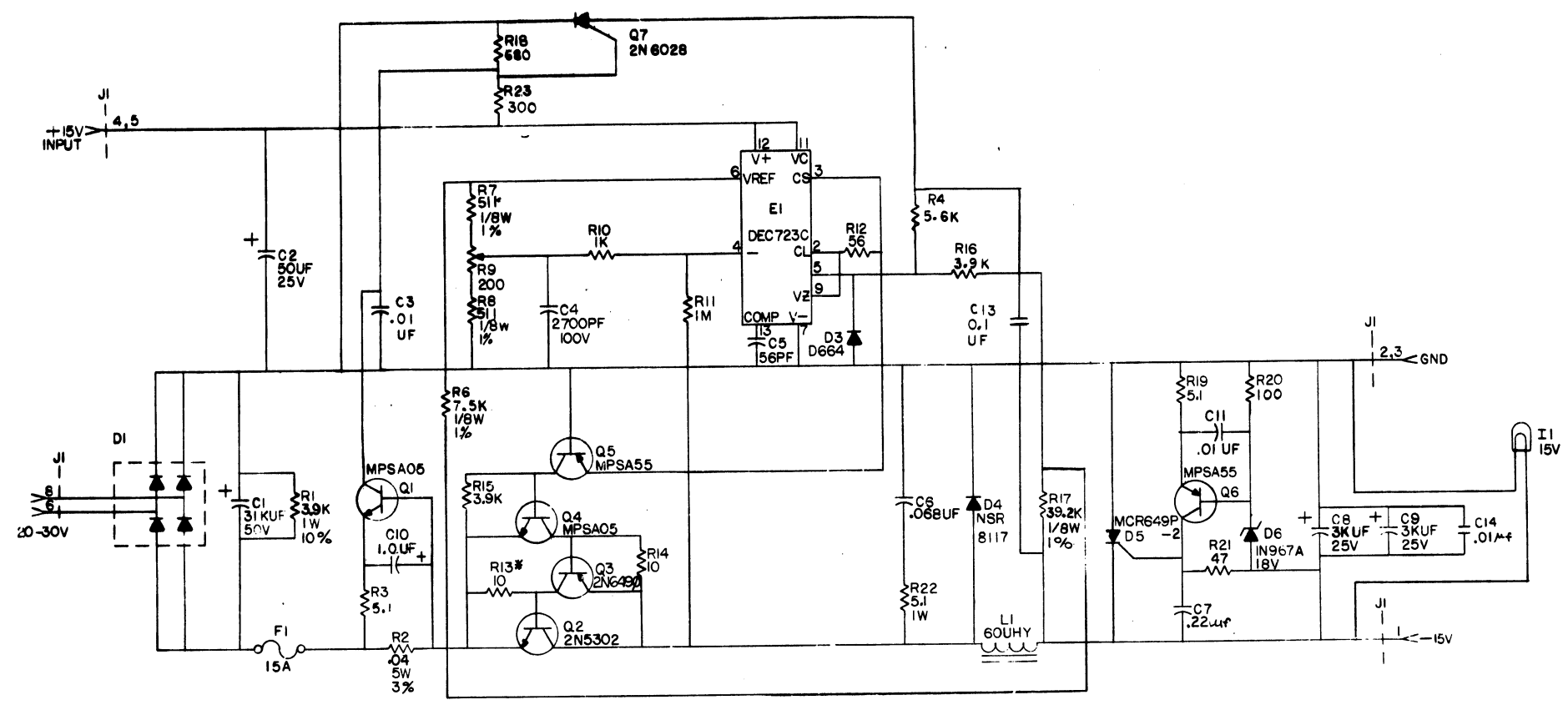

\* FUSIBLE  
UNLESS OTHERWISE INDICATED:  
RESISTORS = 1/4W, 5%

QTY	REF DESIGNATION	DESCRIPTION	PART NO	ITEM NO.
PARTS LIST				
	ETCH BOARD REV	E		
	D664	IN 3606	D45H8	
	NSR 8117		2N 6028	
	MCR 649P - 2			
	IN 967A	SAME		
	2N 5302			
	MPS A05			
	MPS A55			
	DEC NO.	EIA NO.	DEC NO.	EIA NO.
SEMICONDUCTOR CONVERSION CHART				
SCALE		DISTR.		
SHEET		OF		

**DIGITAL EQUIPMENT CORPORATION**  
MAYNARD MASSACHUSETTS

**-15V REG.**

DIST. H745-0-1

H745-0-1

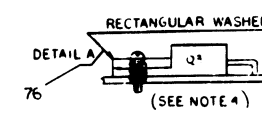
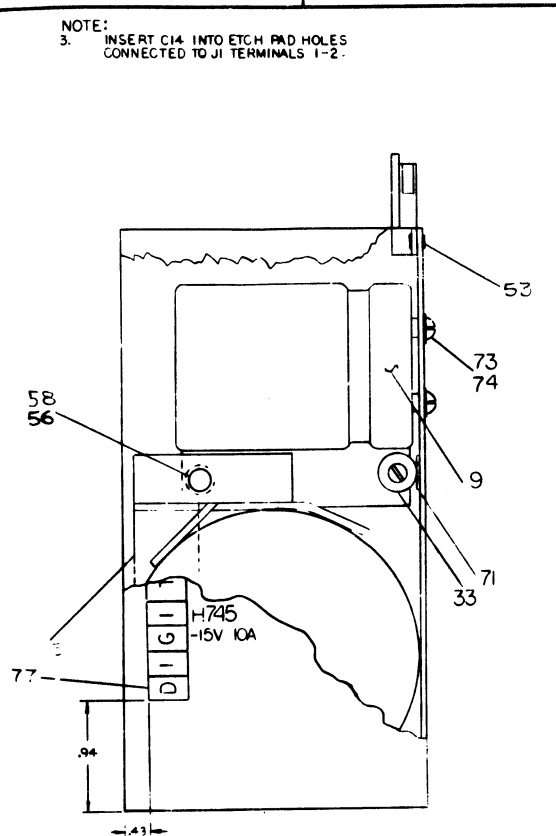
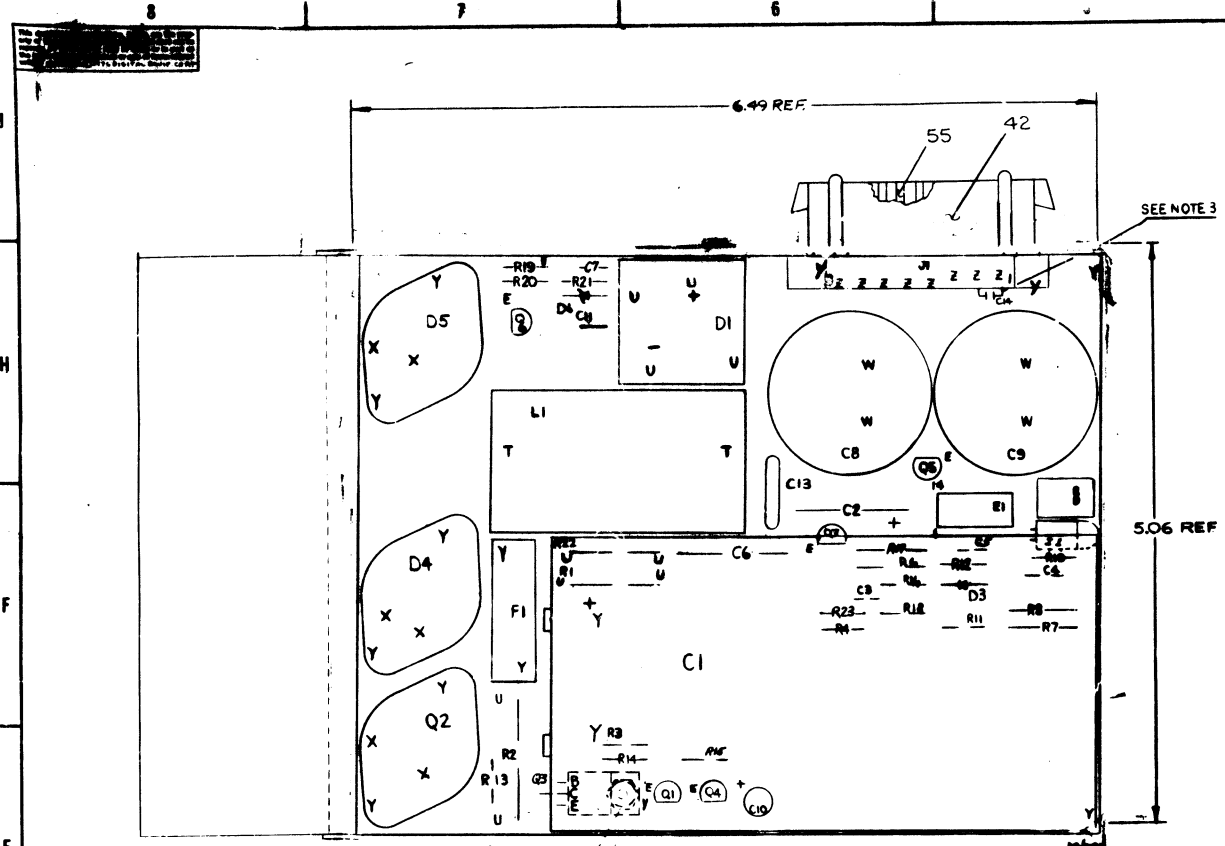

NOTE: 3. INSERT C14 INTO ETCH PAD HOLES CONNECTED TO J1 TERMINALS 1-2.

NOTE: 1. APPLY ITEM # 51 (THERMAL COMPOUND) BETWEEN TRANSISTOR AND INSULATOR, WASHER (ITEM # 52 ALSO BETWEEN WASHER & HEAT SINK FOR Q2, Q4, Q5 ALSO APPLY ITEM # 51 (COMPOUND) BETWEEN ITEM # 11 (CIRCUIT BOARD) AND ITEM # 59 (HEAT SINK). 2. 1010621 MAY BE SUBSTITUTED FOR C13 (1000030).

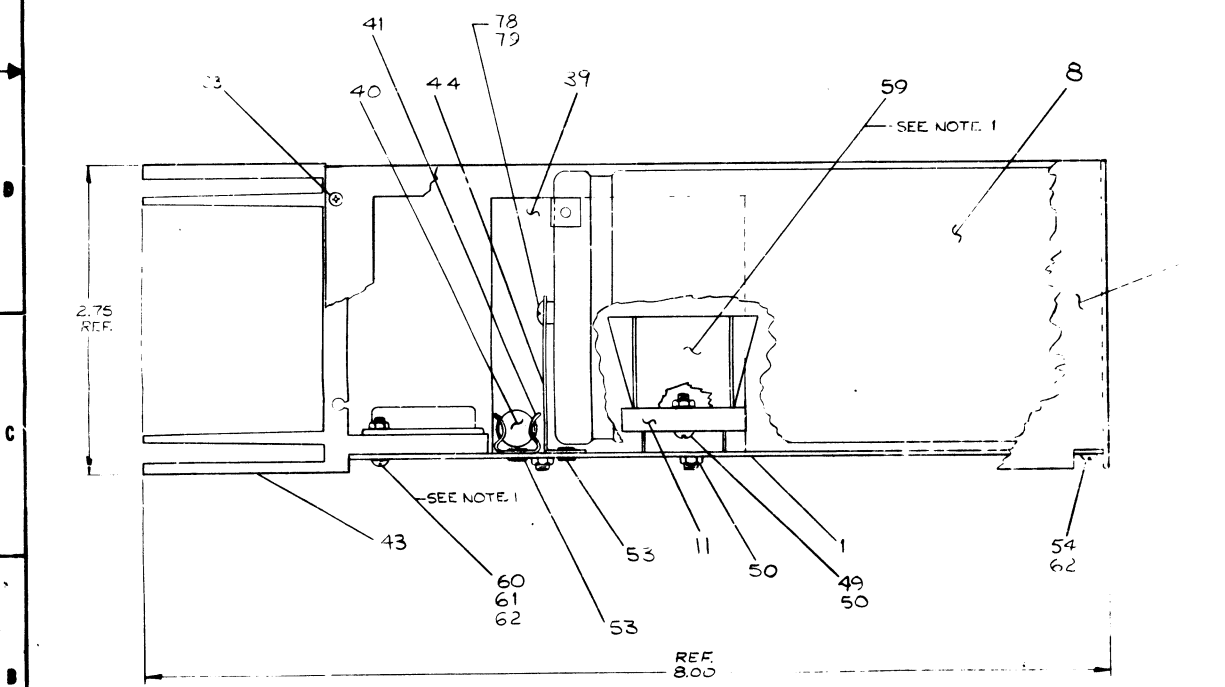

NOTE 4: Q3 SCREW HEAD SHOULD BE ON TOP OF FLAT RECTANGULAR WASHER AS SHOWN. APPLY 6 INCH LBS. OF TORQUE WHEN SECURING Q3 TO CKT. BOARD BEFORE SOLDERING.

NOTE 5: TORQUE APPLICATION (1) APPLY 12 INCH LBS. OF TORQUE TO ALL #4 HARDWARE EXCEPT Q3. (2) APPLY 16 INCH LBS. OF TORQUE TO ALL #6 AND #10 HARDWARE. (3) ALL HARDWARE TO BE TORQUED BEFORE SOLDERING.

ASSY/DRILLING HOLE LAYOUT			
1	PACKING INSTRUCTIONS	API-3700074-0-0	69
1	RES. 560 1/4W 5%	1301424	68
1	RES. 300 1/4W 5%	1301425	67
1	CAP. 0.1UF 100V 20%	1000030	66
1	SCR PH #4-40 X 5/16 LG	9009000-1	65
1	LAMP 15V	1209169	64
4	SCR, PPH #4 X 5/16 LG., SELF TAPPING	9009042	63
1	WASHER #4	9006634	62
7	NUT, #4-40	9005557	61
8	SCR PH. PPH #4-40 X 1 1/2 LG.	1102414	60
1	HEAT SINK BRIDGE RECT.	1210807	59
1	SCR PH. PPH #4-32 X 1, LL	9009200-1	58
1	SCR PH. FLT #4-32 X 1/4 LG.	9001020-02	57
1	WASHER LOCK #8	1001433	56
8	CONTACT FEMALE	1209456	55
2	SCR PH. PPH #4-40 X 1, LG	1102414	54
8	EYELET #5-4	1001025	53
3	INSULATOR WASHER	9009721	52
4	THERMAL COMPOUND	9009206	51
3	NUT #6-32	9008125	50
4	SCR PH. PPH #4-32 X 3/8 LG.	9001025-01	49
4	SCR PH. PPH #4-40 X 1 1/4 LG.	1102414	48
1	INSULATOR BRIDGE	9009721	47
1	REGULATOR BRNT	9-1A-3008736-0-	46
1	2-1 DOUBLE CAPACITOR	9-1A-701230-0-	45
2	STRAP CAPACITOR	9-40-3208736-0-0	44
1	HEAT SINK	9-PS-1210331-0-0	43
1	FINN. W/INSUL- #2X4 X 1 1/2 PIN	1209240	42
2	NUT CLIP	9007200	41
1	FUSE	1211237-01	40
1	REACTOR 60 UHT	1610850	39
1	INTERMATED CIRCUIT BRIDGE	1210815	38
1	TRANSISTOR 2N432	151032-01	37
2	TRANSISTOR 405	1510308	36
2	TRANSISTOR 405	1510305	35
2	TRANSISTOR 2N6302	1510308	34
1	RES VARIABLE 200 OH, 20%	1310852	33
1	RES 100 OH 5%	1302229	32
1	RES 1 MEG OH 5%	1302229	31
1	RES 5.6 X 1/4 W 5%	1321274	30
2	RES 5 OH 1/4 W 5%	1300444	29
2	RES 5 OH 1/4 W 5%	1300442	28
1	RES 5 OH 1/4 W 5%	1300202	27
1	RES 47 OH 5%	1300202	26
1	RES 47 OH 5% 1/4 W 5%	1305274	25
1	RES 10 OH 5%	1305295	24
1	RES 10 OH 5%	1301312	23
1	RES 7.5 OH 1/4 W 5%	1302122	22
1	RES 3 OH 1/4 W 5%	1300911	21
1	RES 5 OH 1/4 W 5%	1302148	20
1	RES 5 OH 1/4 W 5%	1302148	19
1	RES 5 OH 1/4 W 5%	1311762-01	18
1	RES 3 OH 1/4 W 5%	1302927	17
1	BRIDGE	1110886	16
1	SCR W400P-2	1110885	15
1	GLIDE IN30B117	1110215	14
1	GLIDE DM4	1110114	13
1	TRANSISTOR UNI JUNCTION 2N6322	1510277	12
1	GLIDE BRIDGE	1110714	11
1	CAP. 50UF 20V 20%	1001026	10
2	CAP 3.0KUF 25V	1010760	9
1	CAP 51KUF 50V	1010758	8
1	CAP 1.0UF 20V	1010956-01	7
1	CAP 50UF 20V 10-75%	1001026	6
1	CAP 068UF 10V 10%	1000552	5
1	CAP 2700PF 100V 5%	1001031	4
3	CAP 01UF 100V 20%	1001030	3
1	INSULATOR BRIDGE	9009721	2
1	INTERMATED CIRCUIT BOARD	9009721	1
1	TRANSISTOR 405	1510308	
1	TRANSISTOR 405	1510308	
1	TRANSISTOR 2N6302	1510308	
1	RES VARIABLE 200 OH, 20%	1310852	
1	RES 100 OH 5%	1302229	
1	RES 5.6 X 1/4 W 5%	1321274	
2	RES 5 OH 1/4 W 5%	1300444	
2	RES 5 OH 1/4 W 5%	1300442	
1	RES 5 OH 1/4 W 5%	1300202	
1	RES 47 OH 5%	1300202	
1	RES 47 OH 5% 1/4 W 5%	1305274	
1	RES 10 OH 5%	1305295	
1	RES 10 OH 5%	1301312	
1	RES 7.5 OH 1/4 W 5%	1302122	
1	RES 3 OH 1/4 W 5%	1300911	
1	RES 5 OH 1/4 W 5%	1302148	
1	RES 5 OH 1/4 W 5%	1302148	
1	RES 5 OH 1/4 W 5%	1311762-01	
1	RES 3 OH 1/4 W 5%	1302927	
1	BRIDGE	1110886	
1	SCR W400P-2	1110885	
1	GLIDE IN30B117	1110215	
1	GLIDE DM4	1110114	
1	TRANSISTOR UNI JUNCTION 2N6322	1510277	
1	GLIDE BRIDGE	1110714	
1	CAP. 50UF 20V 20%	1001026	
2	CAP 3.0KUF 25V	1010760	
1	CAP 51KUF 50V	1010758	
1	CAP 1.0UF 20V	1010956-01	
1	CAP 50UF 20V 10-75%	1001026	
1	CAP 068UF 10V 10%	1000552	
1	CAP 2700PF 100V 5%	1001031	
3	CAP 01UF 100V 20%	1001030	
1	INSULATOR BRIDGE	9009721	
1	INTERMATED CIRCUIT BOARD	9009721	
1	TRANSISTOR 405	1510308	
1	TRANSISTOR 405	1510308	
1	TRANSISTOR 2N6302	1510308	
1	RES VARIABLE 200 OH, 20%	1310852	
1	RES 100 OH 5%	1302229	
1	RES 5.6 X 1/4 W 5%	1321274	
2	RES 5 OH 1/4 W 5%	1300444	
2	RES 5 OH 1/4 W 5%	1300442	
1	RES 5 OH 1/4 W 5%	1300202	
1	RES 47 OH 5%	1300202	
1	RES 47 OH 5% 1/4 W 5%	1305274	
1	RES 10 OH 5%	1305295	
1	RES 10 OH 5%	1301312	
1	RES 7.5 OH 1/4 W 5%	1302122	
1	RES 3 OH 1/4 W 5%	1300911	
1	RES 5 OH 1/4 W 5%	1302148	
1	RES 5 OH 1/4 W 5%	1302148	
1	RES 5 OH 1/4 W 5%	1311762-01	
1	RES 3 OH 1/4 W 5%	1302927	
1	BRIDGE	1110886	
1	SCR W400P-2	1110885	
1	GLIDE IN30B117	1110215	
1	GLIDE DM4	1110114	
1	TRANSISTOR UNI JUNCTION 2N6322	1510277	
1	GLIDE BRIDGE	1110714	
1	CAP. 50UF 20V 20%	1001026	
2	CAP 3.0KUF 25V	1010760	
1	CAP 51KUF 50V	1010758	
1	CAP 1.0UF 20V	1010956-01	
1	CAP 50UF 20V 10-75%	1001026	
1	CAP 068UF 10V 10%	1000552	
1	CAP 2700PF 100V 5%	1001031	
3	CAP 01UF 100V 20%	1001030	
1	INSULATOR BRIDGE	9009721	
1	INTERMATED CIRCUIT BOARD	9009721	
1	TRANSISTOR 405	1510308	
1	TRANSISTOR 405	1510308	
1	TRANSISTOR 2N6302	1510308	
1	RES VARIABLE 200 OH, 20%	1310852	
1	RES 100 OH 5%	1302229	
1	RES 5.6 X 1/4 W 5%	1321274	
2	RES 5 OH 1/4 W 5%	1300444	
2	RES 5 OH 1/4 W 5%	1300442	
1	RES 5 OH 1/4 W 5%	1300202	
1	RES 47 OH 5%	1300202	
1	RES 47 OH 5% 1/4 W 5%	1305274	
1	RES 10 OH 5%	1305295	
1	RES 10 OH 5%	1301312	
1	RES 7.5 OH 1/4 W 5%	1302122	
1	RES 3 OH 1/4 W 5%	1300911	
1	RES 5 OH 1/4 W 5%	1302148	
1	RES 5 OH 1/4 W 5%	1302148	
1	RES 5 OH 1/4 W 5%	1311762-01	
1	RES 3 OH 1/4 W 5%	1302927	
1	BRIDGE	1110886	
1	SCR W400P-2	1110885	
1	GLIDE IN30B117	1110215	
1	GLIDE DM4	1110114	
1	TRANSISTOR UNI JUNCTION 2N6322	1510277	
1	GLIDE BRIDGE	1110714	
1	CAP. 50UF 20V 20%	1001026	
2	CAP 3.0KUF 25V	1010760	
1	CAP 51KUF 50V	1010758	
1	CAP 1.0UF 20V	1010956-01	
1	CAP 50UF 20V 10-75%	1001026	
1	CAP 068UF 10V 10%	1000552	
1	CAP 2700PF 100V 5%	1001031	
3	CAP 01UF 100V 20%	1001030	
1	INSULATOR BRIDGE	9009721	
1	INTERMATED CIRCUIT BOARD	9009721	
1	TRANSISTOR 405	1510308	
1	TRANSISTOR 405	1510308	
1	TRANSISTOR 2N6302	1510308	
1	RES VARIABLE 200 OH, 20%	1310852	
1	RES 100 OH 5%	1302229	
1	RES 5.6 X 1/4 W 5%	1321274	
2	RES 5 OH 1/4 W 5%	1300444	
2	RES 5 OH 1/4 W 5%	1300442	
1	RES 5 OH 1/4 W 5%	1300202	
1	RES 47 OH 5%	1300202	
1	RES 47 OH 5% 1/4 W 5%	1305274	
1	RES 10 OH 5%	1305295	
1	RES 10 OH 5%	1301312	
1	RES 7.5 OH 1/4 W 5%	1302122	
1	RES 3 OH 1/4 W 5%	1300911	
1	RES 5 OH 1/4 W 5%	1302148	
1	RES 5 OH 1/4 W 5%	1302148	
1	RES 5 OH 1/4 W 5%	1311762-01	
1	RES 3 OH 1/4 W 5%	1302927	
1	BRIDGE	1110886	
1	SCR W400P-2	1110885	
1	GLIDE IN30B117	1110215	
1	GLIDE DM4	1110114	
1	TRANSISTOR UNI JUNCTION 2N6322	1510277	
1	GLIDE BRIDGE	1110714	
1	CAP. 50UF 20V 20%	1001026	
2	CAP 3.0KUF 25V	1010760	
1	CAP 51KUF 50V	1010758	
1	CAP 1.0UF 20V	1010956-01	
1	CAP 50UF 20V 10-75%	1001026	
1	CAP 068UF 10V 10%	1000552	
1	CAP 2700PF 100V 5%	1001031	
3	CAP 01UF 100V 20%	1001030	
1	INSULATOR BRIDGE	9009721	
1	INTERMATED CIRCUIT BOARD	9009721	
1	TRANSISTOR 405	1510308	
1	TRANSISTOR 405	1510308	
1	TRANSISTOR 2N6302	1510308	
1	RES VARIABLE 200 OH, 20%	1310852	
1	RES 100 OH 5%	1302229	
1	RES 5.6 X 1/4 W 5%	1321274	
2	RES 5 OH 1/4 W 5%	1300444	
2	RES 5 OH 1/4 W 5%	1300442	
1	RES 5 OH 1/4 W 5%	1300202	
1	RES 47 OH 5%	1300202	
1	RES 47 OH 5% 1/4 W 5%	1305274	
1	RES 10 OH 5%	1305295	
1	RES 10 OH 5%	1301312	
1	RES 7.5 OH 1/4 W 5%	1302122	
1	RES 3 OH 1/4 W 5%	1300911	
1	RES 5 OH 1/4 W 5%	1302148	
1	RES 5 OH 1/4 W 5%	1302148	
1	RES 5 OH 1/4 W 5%	1311762-01	
1	RES 3 OH 1/4 W 5%	1302927	
1	BRIDGE	1110886	
1	SCR W400P-2	1110885	
1	GLIDE IN30B117	1110215	
1	GLIDE DM4	1110114	
1	TRANSISTOR UNI JUNCTION 2N6322	1510277	
1	GLIDE BRIDGE	1110714	
1	CAP. 50UF 20V 20%	1001026	
2	CAP 3.0KUF 25V	1010760	
1	CAP 51KUF 50V	1010758	
1	CAP 1.0UF 20V	1010956-01	
1	CAP 50UF 20V 10-75%	1001026	
1	CAP 068UF 10V 10%	1000552	
1	CAP 2700PF 100V 5%	1001031	
3	CAP 01UF 100V 20%	1001030	
1	INSULATOR BRIDGE	9009721	
1	INTERMATED CIRCUIT BOARD	9009721	
1	TRANSISTOR 405	1510308	
1	TRANSISTOR 405	1510308	
1	TRANSISTOR 2N6302	1510308	
1	RES VARIABLE 200 OH, 20%	1310852	
1	RES 100 OH 5%	1302229	
1	RES 5.6 X 1/4 W 5%	1321274	
2	RES 5 OH 1/4 W 5%	1300444	
2	RES 5 OH 1/4 W 5%	1300442	
1	RES 5 OH 1/4 W 5%	1300202	
1	RES 47 OH 5%	1300202	
1	RES 47 OH 5% 1/4 W 5%	1305274	
1	RES 10 OH 5%	1305295	
1	RES 10 OH 5%	1301312	
1	RES 7.5 OH 1/4 W 5%	1302122	
1	RES 3 OH 1/4 W 5%	1300911	
1	RES 5 OH 1/4 W 5%	1302148	
1	RES 5 OH 1/4 W 5%	1302148	
1	RES 5 OH 1/4 W 5%	1311762-01	
1	RES 3 OH 1/4 W 5%	1302927	
1			



# DRAWING DIRECTORY

## CUSTOMER PRINT SET INDEX

THIS IS PRINT SET 

--	--	--	--	--	--

DRAWING DIRECTORY  
CIRCUIT SCHEMATIC  
UNIT ASS'Y

SEQUENCE T B-DD-H746-Ø  
D-CS-H746-Ø-1  
E-UA-H746-Ø-Ø

SEQUENCE T MFG SET  
TEST PROCEDURE A-SP-H746-Ø-3  
MFG SPEC. A-SP-H746-Ø-8  
PACKAGING INSTRUCTION A-PI-3700074-O-O

VARIATION	UNIT VARIATIONS TITLE	PRINT SET TYPE					
		H746-1					
H746	MOS REGULATOR	X					

DATE	CHG. NO.	REV
8/22/77	-00005	A
8/23/77	-00006	B
8/24/77	-00007	C
8/24/77	-00012	D
8-76	-00013	E

USED ON OPTION/MODEL	DRN.	DATE	TITLE	SIZE	CODE	NUMBER	REV
11/77			MOS REGULATOR	B	DD		E
	CHK'D	DATE					
	PROJ ENG.	DATE					
	PROD.	DATE					
	FIELD SERV.	DATE					
SHEET 1 OF			DIST				

This drawing and specifications, herein, are the property of Digital Equipment Corporation and shall not be reproduced or copied in whole or in part as the basis for the manufacture or sale of items without written permission.

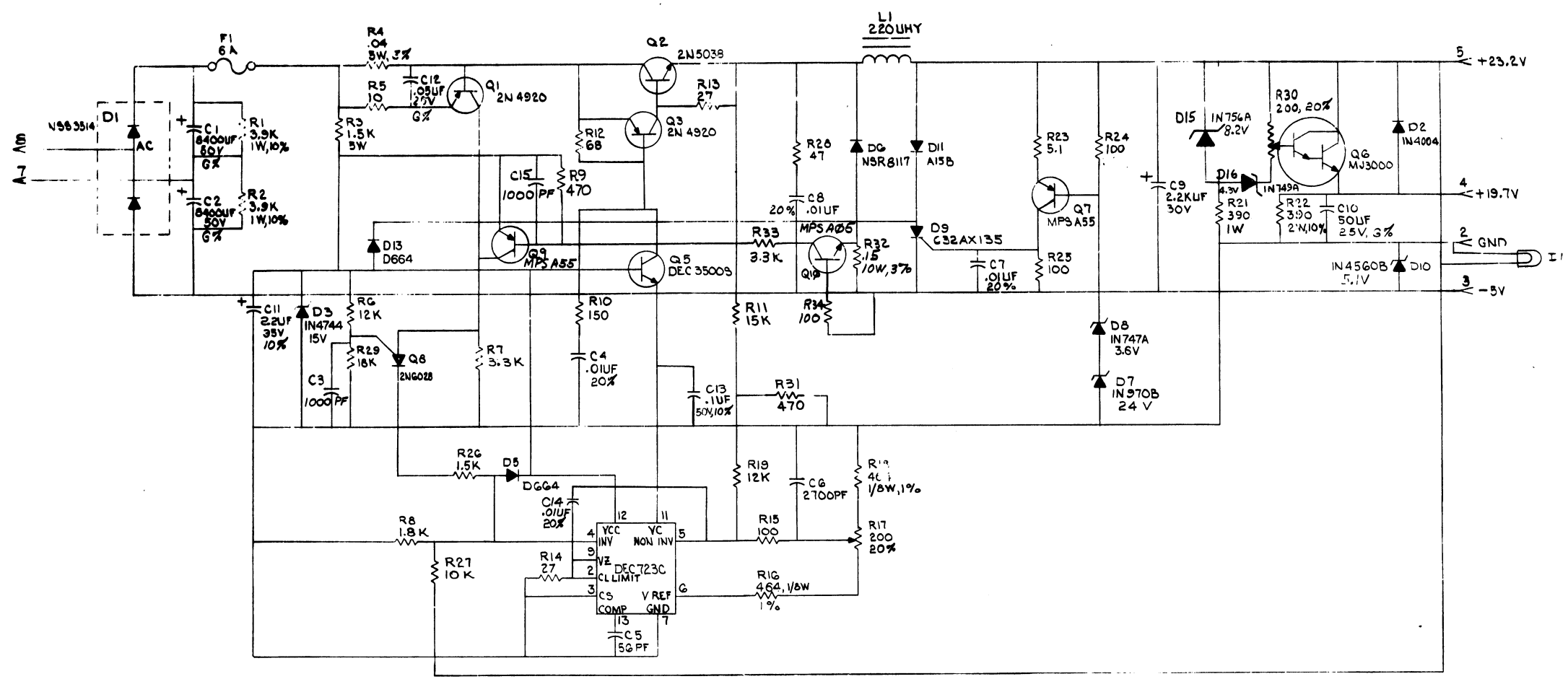

UNLESS OTHERWISE INDICATED:  
 CAPACITORS = 100V, 5%  
 RESISTORS = 1/4W, 5%  
 GX = -10% + 75%

CHK	CHANGE NO.	REV
H/AG	000011/4	1
H/AG	000011/4	2
H/AG	000011/4	3
H/AG	000011/4	4
H/AG	000011/4	5
H/AG	000011/4	6
H/AG	000011/4	7
H/AG	000011/4	8
H/AG	000011/4	9
H/AG	000011/4	10
H/AG	000011/4	11
H/AG	000011/4	12
H/AG	000011/4	13
H/AG	000011/4	14
H/AG	000011/4	15
H/AG	000011/4	16
H/AG	000011/4	17
H/AG	000011/4	18
H/AG	000011/4	19
H/AG	000011/4	20

QTY	REF DESIGNATION	DESCRIPTION	PART NO.	ITEM NO.
PARTS LIST				
ETCH BOARD REV H				
DRN <i>Roger V. ...</i>		DATE 8 Jun 72	 <b>MOS REGULATOR</b>	
CHKD <i>...</i>		DATE 2/1/72		
ENG <i>...</i>		DATE 2/1/72		
PROJ. ENG <i>...</i>		DATE 2/1/72		
NEXT HIGHER ASSY		DATE 2/1/72		
DEC NO.	EIA NO.	DEC NO.	EIA NO.	SCALE
SEMICONDUCTOR CONVERSION CHART				
SHEET		OF		DIST.

DCS H746-0-1 P  
 H746-0-1 P

SEE DRAWING FOR IDENTIFICATION. REFER TO THE TITLE BLOCK FOR THE PART NUMBER AND THE DATE OF THE DRAWING. THE PART NUMBER IS THE SAME AS THE DRAWING NUMBER.

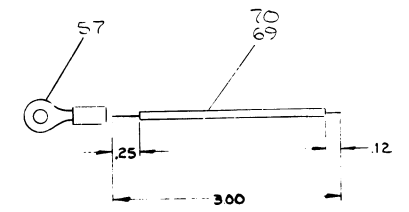
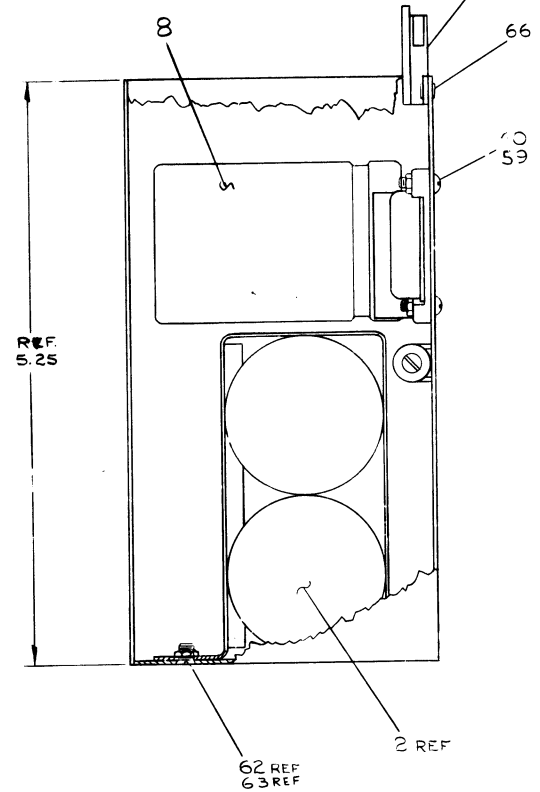
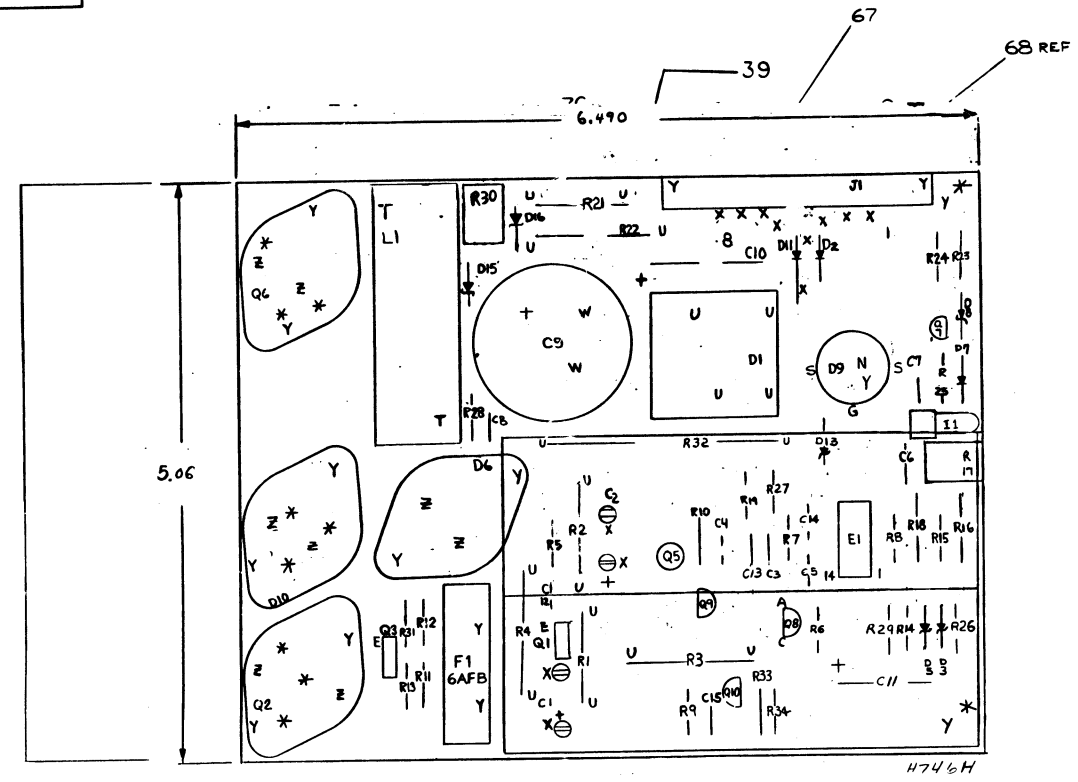

DETAIL "A"  
SEE DRAWING FOR IDENTIFICATION  
RELAY PIN GOES TO POSITIVE TERMINAL  
BLK W/ L GOES TO NEGATIVE TERMINAL

QTY	REF DESIGNATION	DESCRIPTION	PART NO.	ITEM NO.
2	R7, R33	RES. 33K, 1/4 W, 5%	13-00439	29
1	R6	RES. 1.5K, 1/4 W, 5%	13-00398	74
1	R32	RES. 150, 1/4 W, 3%	13-11625	25
1	D9	SCR C 32 AXI 35	15-10926	85
1	Q10	TRANSISTOR A05 (MOT)	15-10705	84
2	C3, C15	CAP. 1000PF, 100V, DM	10-00042	83
1	C13	CAP. 1UF, 50V, 10%	10-10978-36	92
1	R12	RES. 68, 1/4 W, 5%	13-00219	81

NOTE:  
1. APPLY ITEM 71 (COMPOUND) ON:  
I. BOTH SIDES OF INSULATOR WASHERS  
FOR Q2, Q6, D6, D10.  
2. BETWEEN ITEM #11 DIODE BRIDGE (D1)  
AND ITEM #65 HEAT SINK.

QTY	REF DESIGNATION	DESCRIPTION	PART NO.	ITEM NO.
1	D1	DIODE IN 756A	11-03744	73
1	R21	RES. 350, 1/4 W, 5%	13-02384	72
1	L1	LAMP 23V	12-11639	71
2	D10	DIODE IN 747A	11-03744	75
1	DR	DRILLING HOLE LAYOUT	D-AH-746-0-5	
1	P	PACKING INSTRUCTIONS	API-3700074-0-0	89
4		SCR PIN FLAT HD. #4 SELF TAPPING	8009142-02	75
4		WASHER INSULATOR	8001721	72
4	AR	COMPOUND THERMAL	8002658	71
4	AR	#18 ANG. STRE. TCF INS. (BLK)	410280-00	70
4	AR	#18 ANG. STRE. TCF INS. (WHT)	410280-22	69
1		WHT-N LOCK CONN 8 PIN	1708240	59
4		CONTACT FEMULL	1208455	57
4		CONTACT LS-4-7	8076732	66
1		HEAT SINK BRIDGE	1208007	85
1		SCR PIN FLAT HD. 6-32 X 5/4	8006075-1	64
5		KLPS NUT 6-32	8001885	83
4		SCR PIN FLAT HD. 6-32 X 5/16	8007921-2	82
4		SCR PIN FLAT HD. 4-40 X 1.4	800099-2	81
4		KLPS NUT 4-40	8005511	80
4		SCR PIN FLAT HD. 4-40 X 1.4	8005511	80
5		KLPS NUT 4-40	8005511	80
6		SCR PIN FLAT HD. 4-40 X 1.2	8006013-1	58
4		TERMINAL SLING	8007830	57
1		COVER COMP	C-NO-3003160-0	56
1		1.5 CAP BRKT	C-1A-5309798-0-0	55
1		HEAT SINK, REGULATOR	C-PS-1210331-0-0	54
1		BRACKET, REG	C-1A-5309798-0-3	53
4		SPLIT LUG	8006735	52
1	38	TRANSISTOR 2N4320	15-10077	51
2		FUSE CLIP	8007203	50
1	F1	FUSE AGC	8007208	48
1	L1	INDUCTOR 220MH	15-10849	48
1	F1	INTERRUPTER CIRCUITRY 120V	15-10415	47
2	Q1, Q9	TRANSISTOR A05 (MOT)	15-10706	46
1	Q8	TRANSISTOR M3C0000T	15-11349	45
1	Q5	TRANSISTOR EL3C0005	15-09209	44
1	Q2	TRANSISTOR 2N450-18	15-10869	43
2	Q1, Q3	TRANSISTOR 2N4320	15-09805	42
2	R17, R30	RES. VARIABLE 200, 20%	13-10852	41
1	R23	RES. 5.1, 1/4 W, 5%	13-09422	40
2		#10 LOCK WASHER EXTERNAL TOOTH	5002765-1	38
1	E31, P9	RES. 470, 1/4 W, 5%	13-00316	38
1	R11	RES. 15K, 1/4 W, 5%	13-00436	37
1	R10	RES. 150, 1/4 W, 5%	13-00250	36
1	R27	RES. 10K, 1/4 W, 5%	13-00478	34
2	R6, R19	RES. 12K, 1/4 W, 5%	13-00688	33
4	R15, R25, R24, R34	RES. 100, 1/4 W, 5%	13-00219	32
2	R13, R14	RES. 2.2, 1/4 W, 5%	13-01522	31
1	R5	RES. 10, 1/4 W, 5%	13-01317	30
2	R16, R18	RES. 4.7, 1/4 W, 5%	13-03047	27
1	R29	RES. 18K, 1/4 W, 5%	13-02465	26
1	C11	CAP. 2.2UF, 35V, 10%	10-02431	26
1	R4	RES. .045W, 3%	13-11362	24
1	R3	RES. 1.5K, 1/4 W, 5%	13-01897	23
1	R22	RES. 390, 2W, 10%	13-01880	22
1	R28	RES. 1.5K, 1/4 W, 5%	13-00391	21
2	R1, R2	RES. 3.9K, 1/4 W, 10%	13-00927	20
1	R28	RES. 47, 1/4 W, 5%	13-00202	18
1	D11	DIODE IN 5624	11-10426	18
1	D2	DIODE IN 4004	11-55796	12
1	D13	DIODE IN 4560B	11-10455	16
1	D1	DIODE IN 708	11-10656	14
1	D6	DIODE IN 708B117	11-10715	13
1	D3	DIODE IN 4784	11-09648	12
1	D1	DIODE M55 3514	11-10714	11
2	D5, D12	DIODE D684	11-10014	10
1	D10	CAP. 50UF, 25V, 10%	10-01196	8
1	D8	CAP. 2.2UF, 30V	10-10859	7
4	J1, J2, J3, J4, J14	CAP. 100UF, 100V, 5%	10-01610	7
1	J6	CAP. 2700PF, 100V, 5%	10-01631	6
1	J5	CAP. 56PF, 100V, 5%	10-00012	5
1	J15	DIODE IN 743A	11-02377	4
2	C1, C2	CAP. 8.2UF, 50V	10-10851	2
1		ETCHED CIRCUIT BOARD	8001721	1
1		MODULE I/O HISTORY	8-000000-0-6	REF
1		KEY COORDINATE HOLE LOCATION	8-000000-0-4	REF
1		CIRCUIT SCHEMATIC	8-000000-0-1	REF

IC TYPE	QND	+80V	ITEM NO.	AWG	FROM PT	TO PT

IC TYPE	QND	+80V	ITEM NO.	AWG	FROM PT	TO PT

SEMICONDUCTOR CONVERSION CHART

ETLH BOARD REV H

DATE 11/30/66  
BY G.P. POTTER

DEC NO. EIA NO. DEC NO. EIA NO.

SCALE NONE

SHEET 1 OF 1

SEMICONDUCTOR CORPORATION  
WATERTOWN, MASSACHUSETTS

TITLE  
MOS REGULATOR

NUMBER  
H746-0-0

REV. P



THIS DRAWING AND SPECIFICATIONS HEREIN ARE THE PROPERTY OF DIGITAL EQUIPMENT CORPORATION AND SHALL NOT BE REPRODUCED OR COPIED OR USED IN WHOLE OR IN PART AS THE BASIS FOR THE MANUFACTURE OR SALE OF ITEMS WITHOUT WRITTEN PERMISSION. COPYRIGHT © 1972, DIGITAL EQUIPMENT CORPORATION

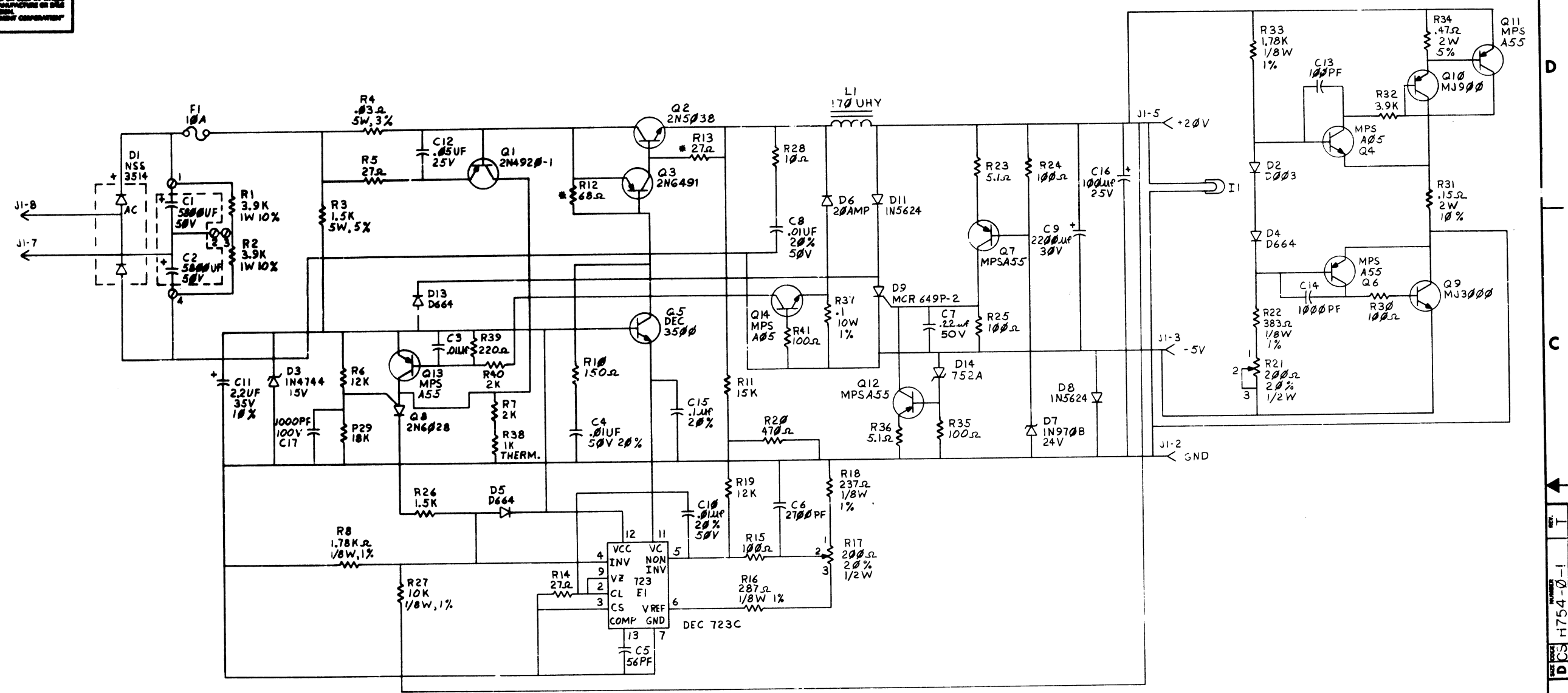

\* FUSIBLE RESISTOR

DRN. BISSONNETTE	8-20-72	FIRST USED ON	H754
CHK'D. VOWLES	12-17-72	TITLE	+20 VOLT REGULATOR
ENG. H. BURTON	5-7-73	SIZE	D
PROJ. ENG. R. BURT	5-7-73	CODE	CS
PROD. L. BAPTISTE	5-7-73	NUMBER	H754-0-1
NEXT HIGHER ASSY.		REV.	T
SCALE		DIST.	
SHEET 2	OF 2		

REV. T  
H754-0-1

WIRE TABLE									
ITEM NO.	WIRE	COLOR	POINT	CONNECTION	TERM	POINT	CONNECTION	TERM	SIGNAL
5	14	RED	3	PS-10	SOLD	18	P1-1	3	+5V
	14	BLK	4	PS-8	SOLD	14	P1-7	3	GND
9	14	GRY	8	PS-4	SOLD	16	P1-2	3	+15V
6	14	BLK	1	PS-12	SOLD	13	P1-9	3	GND
	14	BLU	2	PS-11	SOLD	12	P1-13	3	-15V
8	19	BRN	8	PS-1	SOLD	11	P2-2	5	LTe
7	18	VIO	6	PS-3	SOLD	9	P2-3	3	Dr Lte
	18	YEL	7	PS-2	SOLD	10	P2-4	3	Ac Lte
11	22	-	-	PS-13	SOLD	-	PS-14	SOLD	Dr Lte
11	22	-	-	PS-15	SOLD	-	PS-16	SOLD	Ac Lte

- NOTES:**
- USE TIE WRAPS (X) ITEM #4 APPROXIMATELY EVERY THREE (3) INCHES WHEN NECESSARY AND AT EVERY BREAKOUT POINT.
  - DOT (•) INDICATES NAIL LOCATIONS FOR ASSEMBLY USE ONLY. COVER NAILS WITH SHRINK TUBING TO PREVENT CUTTING HARNESS.
  - USE CONN BRKT C-MD-930576-H5-0 MOUNT WITH WOOD SCREWS. USE MATING CONN 1209350-15.
  - USE CONN BRKT C-MD-930576-H6-0 MOUNT WITH WOOD SCREWS. USE MATING CONN 1209350-06.
  - USE CONN. HOLD DOWN B-MD-930576-0-0 WITH PLATE B-MD-930576-0-1. USE TAPE DEC #9008734 & CONN H807 DEC #1209123 REMOVE PINS & FLANGES AS SHOWN IN DETAIL "A". MOUNT WITH WOOD SCREWS.

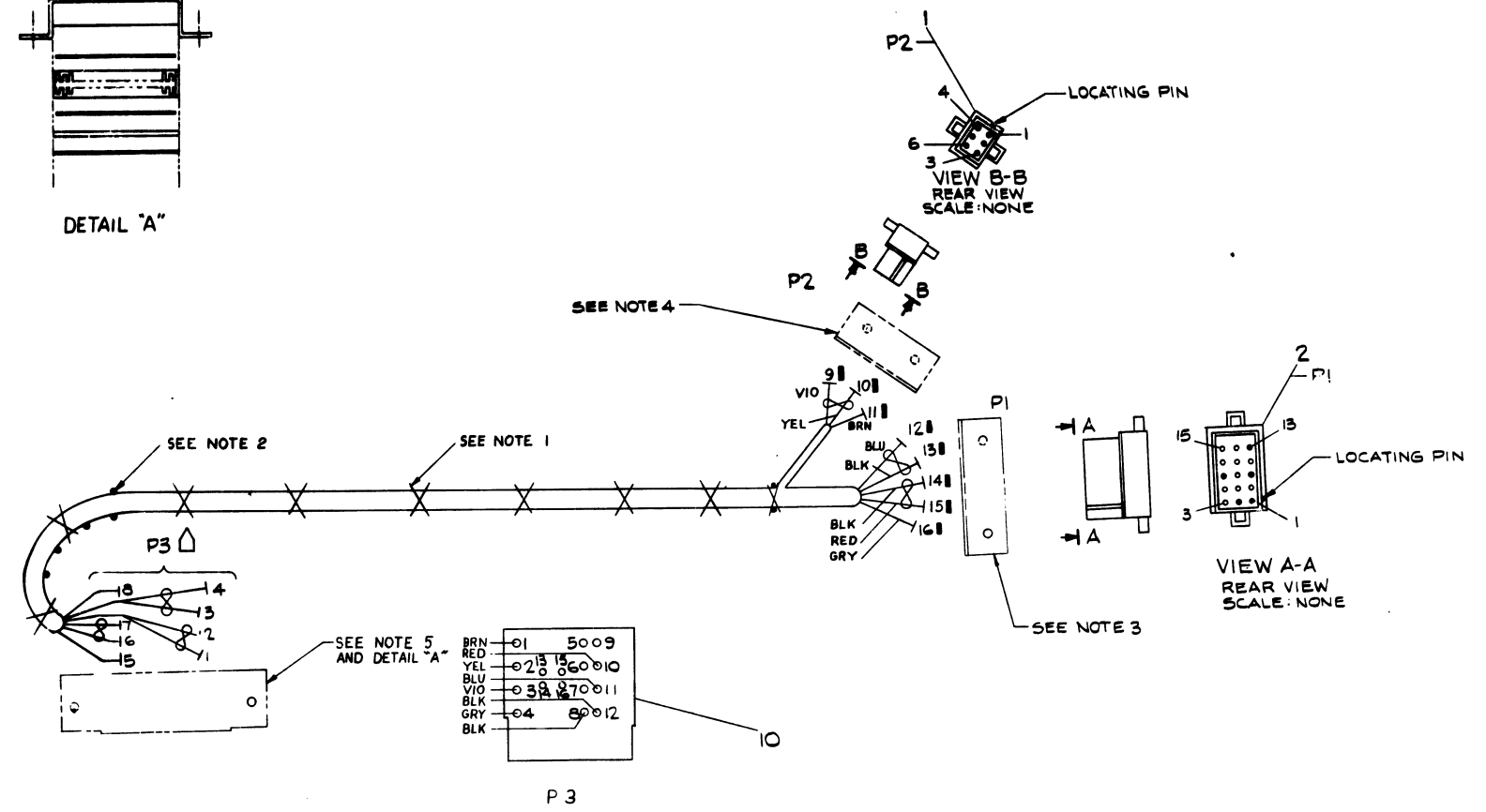
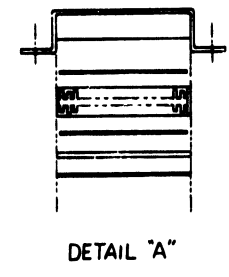

BRN	01	5009
RED	02	150010
YEL	03	270011
BLU	04	80012
VIO		
BLK		
GRY		
BLK		

0 IN.      SCALE      12 IN.  
6 IN.

DO NOT REDUCE  
DO NOT BUILD FROM REDUCED PRINT

**CAUTION - DRAWING SIZE AND SCALE REDUCED FOR MICROFILM NOT TO BE USED FOR PRODUCTION**

WR Buss Wire #22AWG	90756001	11
1 POWER CONN	6772	10
A/R WIRE #14AWG GRY	907570-08	9
A/R WIRE #16AWG BRN	907560-11	8
A/R WIRE #18TWP YEL/VIO	907570-47	7
A/R WIRE #18TWP BLK/BLU	907540-06	6
A/R WIRE #18TWP BLK/RED	907540-02	5
X A/R WRAP TIE	900710-1	4
5 PIN. MALE	1209350-03	3
1 HOUSING CONN. 5PIN	1209350-15	2
1 HOUSING CONN. 6PIN	1209350-06	1

UNLESS OTHERWISE SPECIFIED DIMENSIONS IN INCHES TOLERANCES	DATE	BY	CHKD BY	APPROVED BY
REVISIONS	REV	DESCRIPTION	DATE	BY
1		ISSUED FOR PRODUCTION		
2		REVISED TO CORRECT DIMENSIONS		
3		REVISED TO CORRECT DIMENSIONS		
4		REVISED TO CORRECT DIMENSIONS		
5		REVISED TO CORRECT DIMENSIONS		
6		REVISED TO CORRECT DIMENSIONS		
7		REVISED TO CORRECT DIMENSIONS		
8		REVISED TO CORRECT DIMENSIONS		
9		REVISED TO CORRECT DIMENSIONS		
10		REVISED TO CORRECT DIMENSIONS		
11		REVISED TO CORRECT DIMENSIONS		
12		REVISED TO CORRECT DIMENSIONS		
13		REVISED TO CORRECT DIMENSIONS		
14		REVISED TO CORRECT DIMENSIONS		
15		REVISED TO CORRECT DIMENSIONS		
16		REVISED TO CORRECT DIMENSIONS		
17		REVISED TO CORRECT DIMENSIONS		
18		REVISED TO CORRECT DIMENSIONS		
19		REVISED TO CORRECT DIMENSIONS		
20		REVISED TO CORRECT DIMENSIONS		
21		REVISED TO CORRECT DIMENSIONS		
22		REVISED TO CORRECT DIMENSIONS		
23		REVISED TO CORRECT DIMENSIONS		
24		REVISED TO CORRECT DIMENSIONS		
25		REVISED TO CORRECT DIMENSIONS		
26		REVISED TO CORRECT DIMENSIONS		
27		REVISED TO CORRECT DIMENSIONS		
28		REVISED TO CORRECT DIMENSIONS		
29		REVISED TO CORRECT DIMENSIONS		
30		REVISED TO CORRECT DIMENSIONS		
31		REVISED TO CORRECT DIMENSIONS		
32		REVISED TO CORRECT DIMENSIONS		
33		REVISED TO CORRECT DIMENSIONS		
34		REVISED TO CORRECT DIMENSIONS		
35		REVISED TO CORRECT DIMENSIONS		
36		REVISED TO CORRECT DIMENSIONS		
37		REVISED TO CORRECT DIMENSIONS		
38		REVISED TO CORRECT DIMENSIONS		
39		REVISED TO CORRECT DIMENSIONS		
40		REVISED TO CORRECT DIMENSIONS		
41		REVISED TO CORRECT DIMENSIONS		
42		REVISED TO CORRECT DIMENSIONS		
43		REVISED TO CORRECT DIMENSIONS		
44		REVISED TO CORRECT DIMENSIONS		
45		REVISED TO CORRECT DIMENSIONS		
46		REVISED TO CORRECT DIMENSIONS		
47		REVISED TO CORRECT DIMENSIONS		
48		REVISED TO CORRECT DIMENSIONS		
49		REVISED TO CORRECT DIMENSIONS		
50		REVISED TO CORRECT DIMENSIONS		
51		REVISED TO CORRECT DIMENSIONS		
52		REVISED TO CORRECT DIMENSIONS		
53		REVISED TO CORRECT DIMENSIONS		
54		REVISED TO CORRECT DIMENSIONS		
55		REVISED TO CORRECT DIMENSIONS		
56		REVISED TO CORRECT DIMENSIONS		
57		REVISED TO CORRECT DIMENSIONS		
58		REVISED TO CORRECT DIMENSIONS		
59		REVISED TO CORRECT DIMENSIONS		
60		REVISED TO CORRECT DIMENSIONS		
61		REVISED TO CORRECT DIMENSIONS		
62		REVISED TO CORRECT DIMENSIONS		
63		REVISED TO CORRECT DIMENSIONS		
64		REVISED TO CORRECT DIMENSIONS		
65		REVISED TO CORRECT DIMENSIONS		
66		REVISED TO CORRECT DIMENSIONS		
67		REVISED TO CORRECT DIMENSIONS		
68		REVISED TO CORRECT DIMENSIONS		
69		REVISED TO CORRECT DIMENSIONS		
70		REVISED TO CORRECT DIMENSIONS		
71		REVISED TO CORRECT DIMENSIONS		
72		REVISED TO CORRECT DIMENSIONS		
73		REVISED TO CORRECT DIMENSIONS		
74		REVISED TO CORRECT DIMENSIONS		
75		REVISED TO CORRECT DIMENSIONS		
76		REVISED TO CORRECT DIMENSIONS		
77		REVISED TO CORRECT DIMENSIONS		
78		REVISED TO CORRECT DIMENSIONS		
79		REVISED TO CORRECT DIMENSIONS		
80		REVISED TO CORRECT DIMENSIONS		
81		REVISED TO CORRECT DIMENSIONS		
82		REVISED TO CORRECT DIMENSIONS		
83		REVISED TO CORRECT DIMENSIONS		
84		REVISED TO CORRECT DIMENSIONS		
85		REVISED TO CORRECT DIMENSIONS		
86		REVISED TO CORRECT DIMENSIONS		
87		REVISED TO CORRECT DIMENSIONS		
88		REVISED TO CORRECT DIMENSIONS		
89		REVISED TO CORRECT DIMENSIONS		
90		REVISED TO CORRECT DIMENSIONS		
91		REVISED TO CORRECT DIMENSIONS		
92		REVISED TO CORRECT DIMENSIONS		
93		REVISED TO CORRECT DIMENSIONS		
94		REVISED TO CORRECT DIMENSIONS		
95		REVISED TO CORRECT DIMENSIONS		
96		REVISED TO CORRECT DIMENSIONS		
97		REVISED TO CORRECT DIMENSIONS		
98		REVISED TO CORRECT DIMENSIONS		
99		REVISED TO CORRECT DIMENSIONS		
100		REVISED TO CORRECT DIMENSIONS		

G772 SYSTEM  
UNIT HARNESS

IA 7009562 0 0

DIGITAL EQUIPMENT CORPORATION MAYNARD, MASSACHUSETTS				LEGEND		QUANTITY / VARIATION													
ACCESSORY LIST																			
MADE BY <i>J. Horner</i>		CHECKED <i>J. Horner</i>		SECTION		D DOCUMENT													
DATE <i>6-15-72</i>		DATE <i>6-15-72</i>				DN DOCUMENT CHANGE NOTICE													
ENG <i>J. Horner</i>		PROD <i>J. Horner</i>		ISSUED SECT.		PA PAPER TAPE ASCII													
DATE <i>6/20/72</i>		DATE <i>6-20-72</i>				PB PAPER TAPE BINARY													
						PM PAPER TAPE READ-IN-MODE													
ITEM NO.	DWG NO. / PART NO.	DESCRIPTION				ALL VARIATIONS							KIT CHECK	BY	DATE	INSTALLATION CHECK	BY	DATE	
	Lib Kit 11-Bas 45-B-K	System Software Kit				1													
	Dec 11-H45B-D	11/45 Systems and installation Manual				1													
	112-01071-1854-D-09-25	11 Peripherals and interfacing Handbook				1													
	112-01071-1876-D-09	11/45 Processor Handbook				1													
	Dec 11-HKBA-D	KB11 Maintenance Manual				1													
	B-DD-11/45-0	PDP-11/45 Systems Eng. Drawings				1													
		Dec Supplies List				1													
		Log Book				1													
		PDP-11 Instruction Card				1													
		H960C Cab Filter				1													
	9007221	AGC 5 A Fuse				5													
	9007226	AGC 15A Fuse				5													
	9009039	Fuse 2/10A SB				5													
		Key on off Switch				2													
	7008855	POWER CABLE, SYSTEM UNIT				3													
TITLE		ASSY. NO.		SIZE CODE		NUMBER		REV.		ECO NO									
Central Processor				A AL		11/45 - 015		B		11/45-00065									
SHEET		OF		DIST.															

NOTES:  
 1. SYSTEMS IN ( ) ARE 230V 50 HZ VERSIONS.  
 2. DLIIA SPEED GROUP 3 (300 BAUD ONE STOP BITS, NO PARITY, 8 BITS)  
 3. DLIIA MUST BE SET FOR 150 BAUD TO RUN DIAGNOSTICS.

This drawing and specifications, herein, are the property of Digital Equipment Corporation and shall not be reproduced or copied or used in whole or in part as the basis for the manufacture or sale of items without written permission.

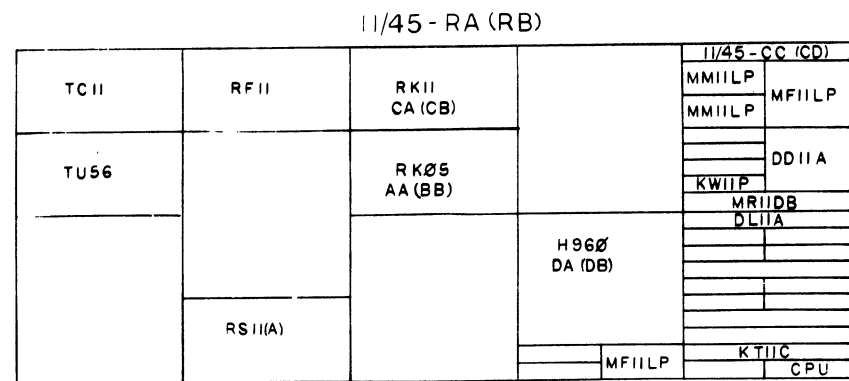

SOFTWARE QR430-AC

LA30  
CA (CD)

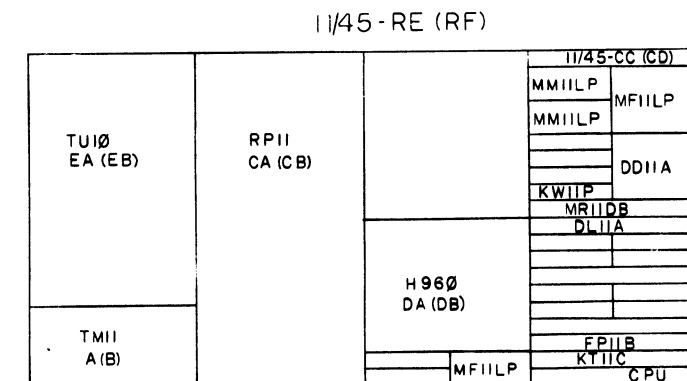

SOFTWARE QR430-AD

RP03  
AS (BS)

LA30  
CA (CD)

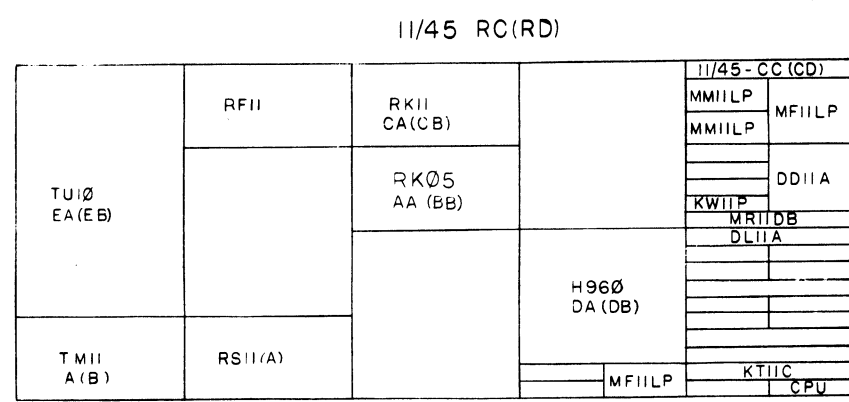

SOFTWARE QR430-AD

LA30  
CA (CD)

CHK	CHANGE NO	REV
11/45-00048	A	A
REVISED & REDRAWN		
B. F. ZSERALD		
M. J. ...		
L. IIAF-00065		
V. BUAEN		

FIRST USED ON OPTION/MODEL	QTY.	DESCRIPTION	PART NO.	ITEM NO.
PDP 11/45				
PARTS LIST				
UNLESS OTHERWISE SPECIFIED DIMENSION IN INCHES TOLERANCES	DRN. B. CRAMM	DATE 11-6-72	DIGITAL EQUIPMENT CORPORATION	
DECIMALS	CHK'D. J. BAILEY	DATE 11-10-72	MAYNARD MASS 01901	
ANGLES	ENG. SWANSON	DATE 1-3-72	TITL	
XX - .006	PROJ. ENG. SWANSON	DATE 1-13-72	TIME SHARING SYSTEMS	
X - .1	PROD. HILGENDORF	DATE	REV.	
REMOVE BURRS AND BREAK SHARP CORNERS SURFACE QUALITY	NEXT HIGHER ASSY.			
MATERIAL	B-DD-11/45-0	SIZE CODE	NUMBER	REV.
FINISH	SCALE	DAR	11/45-0-4	C
	SHEET 1 OF 5	DIST.		

This drawing and specifications herein are the property of Digital Equipment Corporation and shall not be reproduced or copied or used in whole or in part as the basis for the manufacture or sale of items without written permission.

373

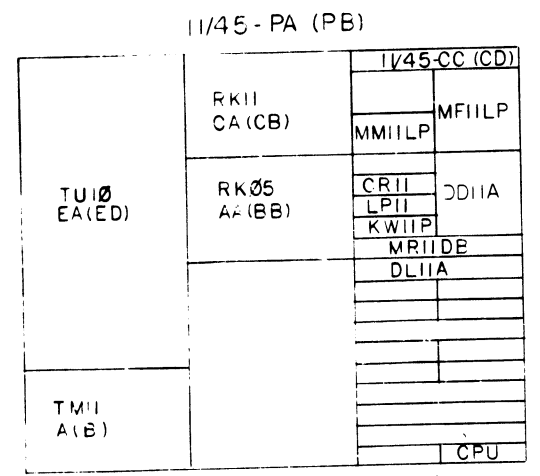

SOFTWARE QJ250-AD

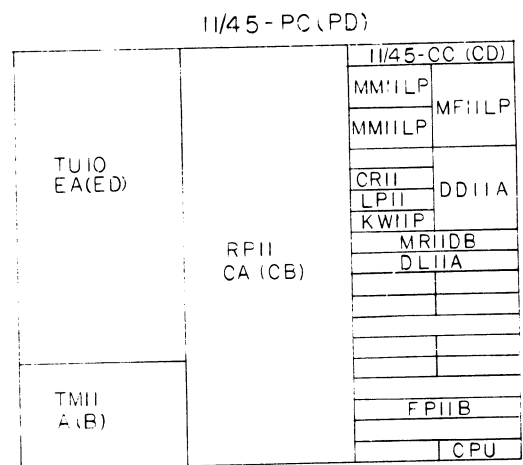
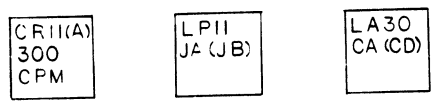

SOFTWARE QJ250-AD

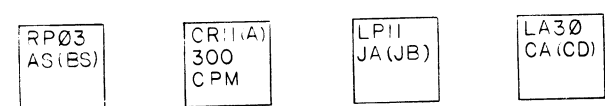

FIRST USED ON OPTION/MODEL	QTY.	DESCRIPTION	PART NO.	ITEM NO.
PDP11/45				
PARTS LIST				
UNLESS OTHERWISE SPECIFIED DIMENSION IN INCHES TOLERANCES	DRN B CRAMM	DATE 1-6-72	<b>digital</b> EQUIPMENT CORPORATION MAYNARD MASSACHUSETTS	
DECIMALS .005 XX .02 X .1	CHK'D J BAILEY	DATE 11-10-72		
ANGLES .0' 30'	ENG SWANSON	DATE 11-13-72	TITLE <b>BATCH PROCESSING SYSTEMS</b>	
REMOVE BURRS AND BREAK SHARP CORNERS SURFAC. QUALITY	PROJ. ENG SWANSON	DATE 11-13-72		
	PROD R HILGENDOERF	DATE		
MATERIAL	NEXT HIGHER ASSY	SIZE CODE	NUMBER	REV.
FINISH	B DD-11/45-0	DAR	11/45-0-4	C
	SCALE	SHEET	DIST	
	2 OF 5			

BRUNING 40.107 15948	REVISIONS	REV.
CHK	CHANGE NO.	

11/45-0-4  
 DAR  
 B

This drawing and specifications herein are the property of Digital Equipment Corporation and shall not be reproduced or copied or used in whole or in part as the basis for the manufacture or sale of items without written permission.

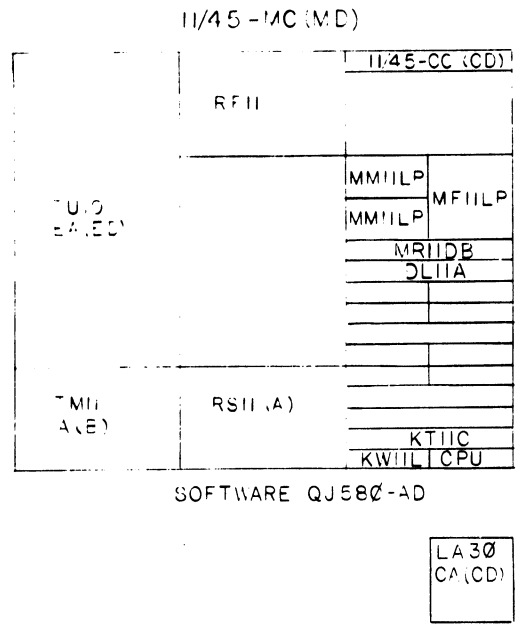
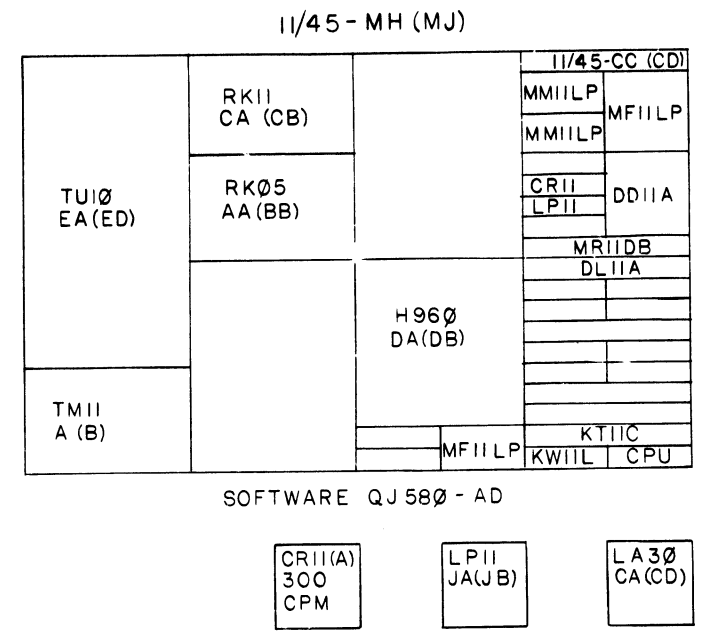
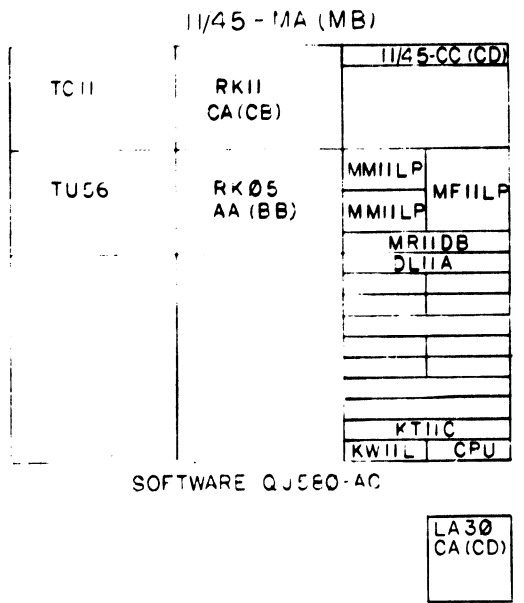

REV. 2  
 11/45-0-4  
 11/45-0-4

FIRST USED ON OPTION/MODEL	QTY.	DESCRIPTION	PART NO.	ITEM NO.
PDP 11/45				
PARTS LIST				
UNLESS OTHERWISE SPECIFIED DIMENSION IN INCHES TOLERANCES	DRN B. CRAMM	DATE 11-8-72	 <b>DIGITAL EQUIPMENT CORPORATION</b> <small>MARLBOROUGH MASSACHUSETTS 01901</small>	
DECIMALS	CHK'D J. BAILEY	DATE 11-10-72		
ANGLES	ENG SWANSON	DATE 11-13-72	TITLE <b>REAL TIME SYSTEMS</b>	
XXX - 000 XX - 02 X - 1	PROJ. ENG SWANSON	DATE 11-13-72		
REMOVE BURRS AND BREAK SHARP CORNERS SURFACE QUALITY	PROD. HILGENDORF	DATE		
MATERIAL	NEXT HIGHER ASSY.		SIZE CODE	NUMBER
FINISH	B:DD-11/45-0		DAR	11/45-0-4
	SCALE		DIST	
	SHEET 3 OF 5			

This drawing and specifications, herein, are the property of Digital Equipment Corporation and shall not be reproduced or copied or used in whole or in part as the basis for the manufacture or sale of items without written permission.

1573

11/45 - DA (DB)

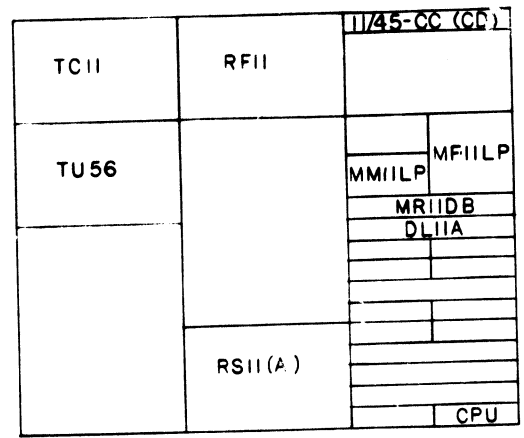

SOFTWARE QJ220-AC

LA 30  
CA (CD)

11/45 - DU (DV)

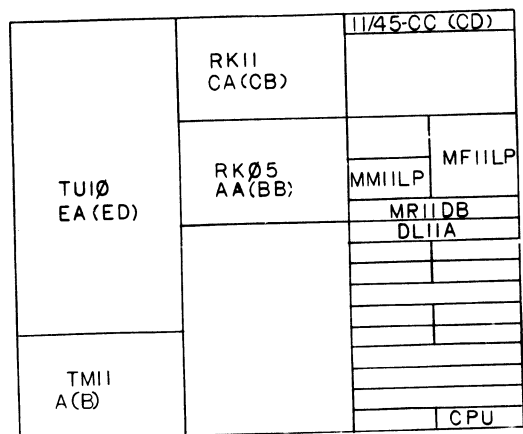

SOFTWARE QJ220-AD

LA 30  
CA (CD)

11/45 - DS (DT)

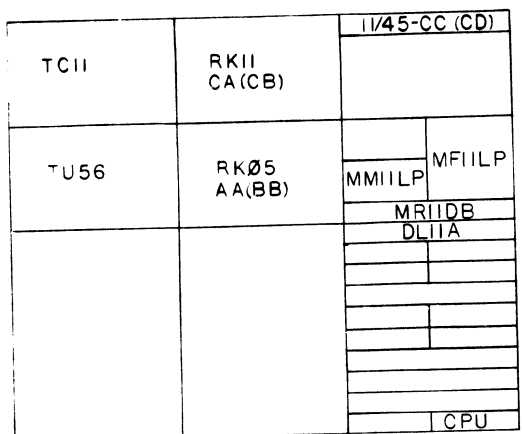

SOFTWARE QJ 220-AC

LA 30  
CA (CD)

REVISIONS	REV
CHANGE NO	
CHK	

FIRST USED ON OPTION/MODEL	QTY.	DESCRIPTION	PART NO.
PDP 11/45			
PARTS LIST			
UNLESS OTHERWISE SPECIFIED DIMENSION IN INCHES TOLERANCES	DRN BCRAMM	DATE 11-6-72	 <b>digital EQUIPMENT CORPORATION</b> <small>MAYNARD MASSACHUSETTS</small>
DECIMALS	CHK'D J. BAILEY	DATE 11-10-72	
ANGLES	ENG. SWANSON	DATE 11-13-72	
XXX - .005 .XX - .02 X - .1	PROJ. ENG. SWANSON	DATE 11-13-72	
REMOVE BURRS AND BREAK SHARP CORNERS SURF/CE QUALITY	PROD. HILGENDORF	DATE	TITLE <b>INTERACTIVE DISK SYSTEMS</b>
MATERIAL	NEXT HIGHER ASSY.	SIZE CODE	NUMBER
	B-DD-11/45-0	DAR	11/45-0-4
FINISH	SCALE	SHEET	REV.
		4 OF 5	C

SHEET NO. 11/45-0-4  
 REV. C

This drawing and specifications herein are the property of Digital Equipment Corporation and shall not be reproduced or copied or used in whole or in part as the basis for the manufacture or sale of items without written permission.

11/45-FC (FD)

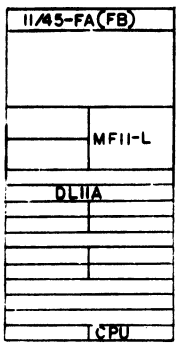

LA30  
CA(CD)

11/45-FE (FF)

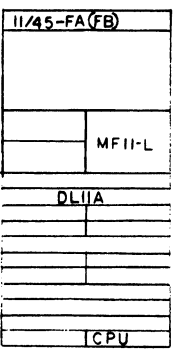

VT05B  
AA(AD)

11/45-GK (GL)

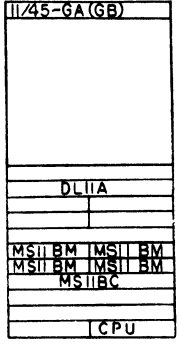

LA30  
CA(CD)

11/45-GP (GR)

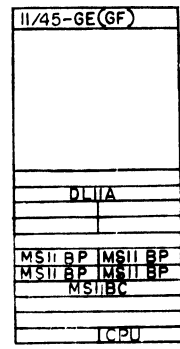

LA30  
CA(CD)

DRAWING NO 107-15888

FIRST USED ON OPTION/MODEL	QTY.	DESCRIPTION	PART NO.	ITEM NO.
PDP-11				
PARTS LIST				
UNLESS OTHERWISE SPECIFIED DIMENSION IN INCHES TOLERANCES	DRN. B C PAMM	DATE 2-22-73	 <b>DIGITAL EQUIPMENT CORPORATION</b> <small>MATHEW MODEL NUMBER 110</small>	
DECIMALS    ANGLES	CHK'D J.M. Callahan	DATE 3-30-73		
XXX - 005	ENG.	DATE	<b>TITLE</b> <b>OEM SYSTEMS</b>	
XX - 02	PROJ ENG	DATE		
X - 1	PROD	DATE		
REMOVE BURRS AND BREAK SHARP CORNERS SURFACE QUALITY ✓	NEXT HIGHER ASSEMBY			
MATERIAL + + +	B-DD-11/45-0		SIZE CODE DAR	NUMBER 11/45-0-4
FINISH + + +	SCALE 5 OF 5	DIST	REV. C	











