

DECstation 2100/3100

Maintenance Guide

March 1991

The information in this document is subject to change without notice and should not be construed as a commitment by Digital Equipment Corporation. Digital Equipment Corporation assumes no responsibility for any errors that may appear in this document.

The software described in this document is furnished under a license and may be used or copied only in accordance with the terms of such license.

Digital Equipment Corporation assumes no responsibility for the use or reliability of its software on equipment that is not supplied by Digital or its affiliated companies.

© Digital Equipment Corporation 1991.
All Rights Reserved
Printed in U.S.A.

USA

This equipment generates, uses, and may emit radio frequency energy. The equipment has been type tested and found to comply with the limits for a Class A computing device pursuant to Subpart J of Part 15 of FCC Rules, which are designed to provide reasonable protection against such radio frequency interference. Operation of this equipment in a residential area may cause interference in which case the user at his own expense will be required to take whatever measures may be required to correct the interference.

The following are trademarks of Digital Equipment Corporation:

DEC
DECnet
DECstation
DECUS
MicroVAX
MicroVMS
PDP

ULTRIX
ULTRIX-32
UNIBUS
VAX
VAXBI
VAXcluster
VAXstation

VMS
VT

digital™

Contents

Using This Guide	xiii
-------------------------------	------

1 General Maintenance

Introduction	1-1
Performing Visual Checks	1-2
Shutting Down the Worksystem Software	1-4
Running the Power-Up Self-Test	1-5
Unsuccessful Power-Up Self-Test	1-7
Running the Self-Test	1-10
Interpreting Self-Test Results	1-11
Interpreting the Status LED Display	1-13
Using the Console Menu	1-14
Console Command Conventions	1-15
Auto Command	1-15
Root Command	1-16
Ctrs Command	1-17
D (Deposit) Command	1-18
Disable Command	1-18
Dump Command	1-19
E (Examine) Command	1-19
Enable Command	1-20
Fill Command	1-20
Go Command	1-21
Help Command	1-21
? Command	1-21
Init Command	1-22
Passwd Command	1-22
Printenv Command	1-23

Setenv Command	1-26
Test Command	1-27
Unsetenv Command	1-28
Warm Command	1-29
Using the SCSI Menu	1-30
SCSI Test Levels	1-30
Booting the Worksystem Software	1-36
Unsuccessful Worksystem Software Boot	1-36

2 Extended Self-Tests

Overview	2-1
Console Extended Self-Tests	2-1
SCSI Extended Self-Tests	2-4
Diagnostic Aids	2-5
Diagnosing Intermittent Failures	2-5
Connecting an Alternate Console	2-5
Preparing for Console Extended Self-Tests	2-7
Viewing Test Commands	2-7
Selecting Test Modes	2-9
Terminating Connectors	2-11
Installing the Internal SCSI Loopback Connector	2-11
Running Console Extended Self-Tests	2-13
System Test	2-13
Memory Report	2-14
Color Mask Test	2-14
Cache Test	2-15
DZ Test	2-16
Disk RAM Test	2-17
ESAR Test	2-17
FPU Test	2-18
Video Test Patterns Test	2-18
Keyboard Test	2-19
LANCE Test	2-19
LEDs Test	2-20
Main RAM Test	2-21
Net RAM Test	2-22
Mouse Test	2-22
PCC Test	2-23
CSR Test	2-24
RTC Test	2-24
SII Test	2-25
TLB Test	2-28

VDAC Test	2-29
Video RAM Test	2-29
Write Buf Test	2-30
Preparing for SCSI Extended Self-Tests	2-31
Viewing the SCSI Storage Device Listing	2-31
Running SCSI Extended Self-Tests	2-32
Canned Disk Test	2-33
Canned Floppy Disk Test	2-34
Canned Tape Test	2-35
Canned CDROM Disc Test	2-36
Extended Self-Test	2-36
t1—SII Buffer Test	2-37
t2—SII Target Mode Test	2-38
t3—SII Initiator Mode Test	2-39
t4—SCSI Loopback and External Drive Tests	2-41
SCSI Extended Self-Tests Troubleshooting	2-43
SII Errors—Code 0x0bd	2-43
SII Timeout Errors—Code 0x0be	2-43
SII Target and Initiator Tests	2-44
SCSI Errors—Code 0x0bf	2-44
SCSI Bus Troubleshooting	2-44
SCSI Device Errors—Code 0x0d3	2-46
Running Extended Self-Tests Without a Functioning Monitor	2-47
Interpreting the Status LED Codes	2-47

3 Base System FRU Replacement

Base System FRUs	3-4
Removing the System Unit Cover	3-5
Removing the Drive Mounting Panel	3-6
Disk Drive Replacement: Non-Floppy Mounting Panel	3-8
Preparing the RZ23/RZ23L/RZ24 Disk Drive Assembly	3-9
Replacing an Internal RZ23/RZ23L/RZ24 Disk Drive	3-10
Installing Add-On RZ23/RZ23L/RZ24 Disk Drives	3-12
Disk Drive Replacement: Floppy Mounting Panel	3-14
RX23 Installation Package Contents	3-14
RZ23/RZ23L/RZ24 Hard Disk Drive Installation Package Contents	3-15
Replacing an Internal RX23 Disk Drive	3-17
Installing an Add-on RX23 Disk Drive	3-21
Replacing an RZ23/RZ23L/RZ24 Disk Drive (Floppy Panel)	3-24

Installing Add-on RZ23/RZ23L/RZ24 Disk Drives (Floppy Panel)	3-25
Before adding-on an RZ23/RZ23L/RZ24 disk drive	3-25
To install the RZ23/RZ23L/RZ24	3-26
Replacing D SIM Modules	3-27
Installing Add-on D SIM Modules	3-29
Replacing Video SIM Modules	3-31
Replacing the Battery Pack	3-33
Replacing the System Module	3-35
Replacing the System EPROMs	3-38
Replacing the Power Supply Assembly	3-39

A Equipment Specifications

DECstation 2100/3100 System Unit Equipment Specifications	A-2
VR150 Monitor Equipment Specifications	A-3
VR160 Monitor Equipment Specifications	A-5
VR262 Monitor Equipment Specifications	A-8
VR297 Monitor Equipment Specifications	A-10
VR299 Monitor Equipment Specifications	A-12
LK201 Keyboard Equipment Specifications	A-14
VSXXX-AA Mouse Equipment Specifications	A-16
RZ55 SCSI Hard Disk Drive Equipment Specifications	A-18
TK50Z Tape Drive Equipment Specifications	A-20
TLZ04 Cassette Tape Drive Equipment Specifications	A-22
RRD40 Compact Disc Drive Equipment Specifications	A-23
RZ23 SCSI Hard Disk Drive Equipment Specifications	A-24
RZ23L SCSI Hard Disk Drive Equipment Specifications	A-26
RZ24 SCSI Hard Disk Drive Equipment Specifications	A-28
RX23 Diskette Drive Equipment Specifications	A-30

B Part Numbers

C R2000 CPU Registers

System Control Coprocessor Registers	C-1
EntryHi and EntryLo Registers	C-3
EntryHi Register	C-3
EntryLo Register	C-4
Index and Random Registers	C-5
TLB Index Register	C-5
TLB Random Register	C-5
Bad Virtual Address and Context Registers	C-7
Bad Virtual Address Register	C-7
Context Register	C-7
Status and Cause Registers	C-9
Status Register	C-9
Diagnostic Status	C-10
Cause Register	C-12
Exception Program Counter (EPC)	C-14

D Status and Error Code Descriptions

Index

Figures

1-1	On/Off Switch	1-5
1-2	Successful Power-Up Self-Test Display	1-6
1-3	Reset Button	1-8
1-4	Status LED display	1-9
1-5	Console Menu	1-14
1-6	Environment Variable Table	1-23
1-7	Sample Configuration Table	1-28
1-8	SCSI Menu	1-32
2-1	Printer/Console Connector Location	2-6
2-2	Diagnostic Options Menu	2-8
2-3	Sample Memory Report Display	2-14
2-4	Sample Color Plane Mask Test Display	2-15
2-5	Sample Cache Test Display	2-15
2-6	Sample DZ Test Display	2-16
2-7	Sample Disk RAM Test Display	2-17
2-8	Sample ESAR Test Display	2-17

2-9	Sample FPU Test Display	2-18
2-10	Sample Keyboard Test Display	2-19
2-11	Sample LANCE Test Display	2-20
2-12	Sample LEDs Test Display	2-20
2-13	Sample Main RAM Test Display	2-21
2-14	Sample Net RAM Test Display	2-22
2-15	Sample Mouse Test Display	2-22
2-16	Sample PCC Test Display	2-23
2-17	Sample CSR Test Display	2-24
2-18	Sample RTC Test Display	2-25
2-19	Sample SII Test Display	2-26
2-20	Sample TLB Test Display	2-28
2-21	Sample VDAC Test Display	2-29
2-22	Sample Write Buf Test Display	2-30
2-23	SCSI Device List	2-31
2-24	Sample Canned Disk Test Display	2-33
2-25	Sample Canned Floppy Disk Test Display	2-34
2-26	Sample Canned Tape Test Display	2-35
2-27	Sample Canned CDROM Test Display	2-36
2-28	Extended Mode Self-Test Display	2-37
2-29	Sample t1 Test Display	2-38
2-30	Sample t2 Test Display	2-39
2-31	Sample t3 Test Display	2-40
2-32	Sample t4 Test Display	2-42
3-1	Removing the System Unit Cover	3-5
3-2	Removing the Drive Mounting Panel	3-7
3-3	Removing an RZ23/RZ23L/RZ24 Disk Drive (Non-Floppy Panel)	3-11
3-4	Floppy Mounting Panel Component Location	3-16
3-5	Disk Drive Removal From a Floppy Mounting Panel	3-18
3-6	Floppy Disk Drive SCSI ID Switches	3-20
3-7	Floppy Disk Drive Bezel Installation	3-22
3-8	Removing a D SIM Module	3-28
3-9	Removing the Video SIM Module	3-32
3-10	Removing the Battery Pack	3-34
3-11	Removing the System Module	3-35
3-12	ESAR Chip Location	3-37
3-13	Replacing the System EPROMs	3-38
3-14	Removing the Power Supply Assembly	3-40

B-1	DECstation 2100/3100 Unit Assembly	B-2
-----	--	-----

Tables

1-1	Visual Check Problems	1-2
1-2	Interpreting Test Codes	1-11
1-3	LED Power-Up Self-Test Display Codes	1-13
1-4	Default Environment Variables	1-24
1-5	SCSI Commands	1-33
2-1	Console Extended Self-Tests	2-2
2-2	SCSI Extended Self-Tests	2-4
2-3	Test Modes	2-10
2-4	Test Mode Terminators	2-11
2-5	LED Extended Self-Test Display Codes	2-48
3-1	DECstation 2100/3100 Monitor Reference	3-2
3-2	External Device Reference	3-3
3-3	Unit Select Jumper Settings	3-12
3-4	D SIM Memory Module Locations	3-30
A-1	System Unit Description	A-2
A-2	System Unit Operating Conditions	A-2
A-3	System Unit Nonoperating Conditions	A-2
A-4	VR150 Monitor Description	A-3
A-5	VR150 Monitor Operating Conditions	A-4
A-6	VR150 Monitor Nonoperating Conditions	A-4
A-7	VR160 Monitor Description	A-5
A-8	VR160 Monitor Operating Conditions	A-6
A-9	VR160 Monitor Nonoperating Conditions	A-7
A-10	VR262 Monitor Description	A-8
A-11	VR262 Monitor Operating Conditions	A-9
A-12	VR262 Monitor Nonoperating Conditions	A-9
A-13	VR297 Monitor Description	A-10
A-14	VR297 Monitor Operating Conditions	A-11
A-15	VR297 Monitor Nonoperating Conditions	A-11
A-16	VR299 Monitor Description	A-12
A-17	VR299 Monitor Operating Conditions	A-13
A-18	VR299 Monitor Nonoperating Conditions	A-13
A-19	LK201 Keyboard Description	A-14
A-20	LK201 Keyboard Operating Conditions	A-14
A-21	LK201 Keyboard Nonoperating Conditions	A-15

A-22	VSXXX-AA Mouse Description	A-16
A-23	VSXXX-AA Mouse Operating Conditions	A-16
A-24	VSXXX-AA Mouse Nonoperating Conditions	A-17
A-25	RZ55 SCSI Hard Disk Drive Description	A-18
A-26	RZ55 SCSI Hard Disk Drive Operating Conditions	A-19
A-27	RZ55 SCSI Hard Disk Drive Nonoperating Conditions	A-19
A-28	TK50Z Tape Drive Description	A-20
A-29	TK50Z Tape Drive Operating Conditions	A-20
A-30	TK50Z Tape Drive Nonoperating Conditions	A-21
A-31	TLZ04 Cassette Tape Drive Description	A-22
A-32	TLZ04 Cassette Tape Drive Operating Conditions	A-22
A-33	TLZ04 Cassette Tape Drive Nonoperating Conditions	A-22
A-34	RRD40 Compact Disc Drive Description (Tabletop)	A-23
A-35	RRD40 Compact Disc Drive Operating Conditions (Tabletop)	A-23
A-36	RRD40 Compact Disc Drive Nonoperating Conditions (Tabletop)	A-23
A-37	RZ23 SCSI Hard Disk Drive Description	A-24
A-38	RZ23 SCSI Hard Disk Drive Operating Conditions	A-24
A-39	RZ23 SCSI Hard Disk Drive Nonoperating Conditions	A-25
A-40	RZ23L SCSI Hard Disk Drive Description	A-26
A-41	RZ23L SCSI Hard Disk Drive Operating Conditions	A-26
A-42	RZ23L SCSI Hard Disk Drive Nonoperating Conditions	A-27
A-43	RZ24 SCSI Hard Disk Drive Description	A-28
A-44	RZ24 SCSI Hard Disk Drive Operating Conditions	A-28
A-45	RZ24 SCSI Hard Disk Drive Nonoperating Conditions	A-29
A-46	RX23 Diskette Drive Description	A-30
A-47	RX23 Diskette Drive Operating Conditions	A-31
A-48	RX23 Diskette Drive Nonoperating Conditions	A-31
B-1	Loopback Connectors/Plugs/Test Media	B-1
B-2	Major FRUs	B-3
B-3	Basic Components	B-4
B-4	BA42 Storage Expansion Box Configuration	B-5
B-5	Cords, Cables, and Connectors	B-6
B-6	Software Documentation	B-7
B-7	Hardware Documentation	B-8
C-1	System Control Coprocessor Numbering	C-2
C-2	Exception Codes	C-14
D-1	Status and Error Code Locator	D-1

D-2	Console and Boot Status Codes.....	D-2
D-3	Console and Boot Error Codes	D-3
D-4	Diagnostic Status Codes.....	D-9
D-5	Diagnostic Error Codes	D-12
D-6	SCSI/SII Status Codes	D-19
D-7	SCSI/SII Error Codes	D-22

PAGE xii INTENTIONALLY LEFT BLANK

Using This Guide

Purpose

This document provides information about how to isolate hardware failures that occur during operation of the DECstation 2100/3100/3100S workstations and servers. It contains procedures for running diagnostic self-tests and replacing field-replaceable units (FRUs).

Most of the instructions in this document are applicable to all systems. Configuration differences are described in Special Instructions for Other Configurations later in this section.

Intended Audience

Users of this manual are Digital service personnel who are required to provide support and maintenance for the DECstation 2100/3100/3100S hardware. Other users include customers who have a self-maintenance agreement with Digital.

Familiarity with running hardware diagnostics is helpful but not required. It is assumed that readers are experienced with replacing hardware components and have attended the Digital training course, *DECstation 3100 Operations and Servicing*. Contact Digital Educational Services for course information.

Document Structure

This guide contains the following chapters and appendixes:

Chapter Number	Title	Description
1	General Maintenance	This chapter describes how to shut down the operating system, run and interpret the power-on self-test, use the console menu, and reboot the system.
2	Extended Self-Tests	This chapter explains how to run and interpret the DECstation 3100 extended self-tests.
3	Base System FRU Replacement	This chapter contains instructions for replacing FRUs that diagnostic tests have indicated are faulty.
Appendix A	Specifications	This appendix lists the SCSI ID switch settings, power supply specifications, and environmental requirements.
Appendix B	Part Numbers	This appendix lists the part numbers for the basic system units, add-ons, and related documentation.
Appendix C	R2000 CPU Registers	This appendix describes the register information that the workstation can display when an exception error occurs.
Appendix D	Status and Error Code Descriptions	This appendix lists and describes status and error code messages that the workstation can display.

Associated Documents

The following documents provide additional information about the DECstation 3100:

- *DECstation 2100/3100 Hardware Installation Guide*
- *DECstation 3100 Operations and Servicing Course Guide*
- *DECstation 2100/3100 Operator's Guide*
- *DECstation 3100S Server Hardware Installation Guide*

Conventions

The following conventions are used in this document:

Convention	Description
checking	Text displayed on the screen appears in a monospaced type.
test -a	Text you type appears in a bold type.
[r]	Text appearing in square brackets indicates optional arguments you type on a command line.
arg	The word, arg, indicates you must type an argument on a command line.
Type	The word, type, indicates you type text using the keyboard and press the Return key.
Warning:	Warnings provide information to prevent personal injury.
Caution:	Cautions provide information to prevent damage to the equipment.
Note:	Notes provide general operating information.

Special Instructions for Other Configurations

Throughout this document it is assumed that the equipment you are working on is the DECstation 3100. Other versions of the DECstation 3100 differ only in configuration and are described below.

Troubleshooting instructions for the systems described in the table on the following page are the same as for the DECstation 3100 except for configuration differences.

Configuration notes:

- Systems with console terminals:
 - The console terminal serial line cable plugs into the printer/console connector on the back of the system unit.
 - The keyboard is connected to the console terminal, not the system unit.
- If a mouse is not supported, a mouse loopback plug is required.
- If internal drives are not supported, a shorter internal SCSI cable connects the panel SCSI directly to the system board SCSI connector.
- The DECstation 2100/3100 displays status and error messages accompanied by a message number. Descriptions of the status and error messages can be found in Appendix D.

If your system does not display error codes, refer to *Running Extended Self-Tests Without a Functioning Monitor*. That section will help you to interpret the error codes by using the LED displays. For more information on SCSI troubleshooting, refer to *SCSI Extended Self-Tests Troubleshooting*.

DECstation 2100/3100/3100S Configurations

	DECstation		
	2100	3100	3100S
Memory - Mbytes	8-24	8-24	24
Clock - MHz	12.5	16.67	16.67
V SIM Installed	Yes	Yes	No

Maximum Devices

Internal/External:	2/4	2/4	0/5
Ext. Only (BA40)	4	4	5
Ext. Only (BA42)	6	6	n/a

Storage Devices:

RZ23 Int. (104 Mbytes)	Yes	Yes	No
RZ23L Int. (121 Mbytes)	Yes	Yes	No
RZ24 Int. (209 Mbytes)	Yes	Yes	Yes
RZ55/BA40 (332 Mbytes)	Yes	Yes	Yes
RZ55/BA42 (664 Mbytes)	Yes	Yes	No
TK50Z (95 Mbytes)	Yes	Yes	Yes

Other Devices:

Console Terminal	No	No	Yes
Mouse Supported	Yes	Yes	No

General Maintenance

Introduction

The DECstation 2100/3100 is a high-performance, desktop ULTRIX workstation based on reduced instruction set computer (RISC) technology. This chapter describes the following general maintenance procedures:

- Visually checking the equipment
- Shutting down the worksystem software
- Running the self-tests
- Interpreting the self-tests
- Using the Console menu
- Using the Small Computer System Interface (SCSI) menu
- Booting the worksystem software after running diagnostics

Performing Visual Checks

Examine all external connections, cables, power cords, and monitor operation. Table 1-1 describes common problems you can encounter.

Table 1-1. Visual Check Problems

Problem	Cause	Action
The monitor screen is dark.	Monitor is not turned on.	Turn monitor on/off switch to the on position (1).
	The power cord is not connected properly.	Make sure monitor power cord is seated properly in its power source.
	The monitor controls are not adjusted properly.	Adjust the brightness and contrast controls on the side or front of your particular monitor. Refer to the appropriate monitor installation guide for directions.
	The monitor-system unit cable connectors are not tightly secured.	Make sure that connectors on the monitor cable are tightly secured to the connectors on the monitor and on the back panel of the system unit. Perform the extended self-tests described in Chapter 2. Replace the monitor.
The monitor display is wrong color.	Red and blue video cable connectors are not secured correctly	Refasten red and blue video cables at back of system unit.
		Replace video cable. Perform the extended self-tests described in Chapter 2. Replace the monitor.
Monitor display is distorted, flickering, or rolling.	The monitor-system unit cable is not secured correctly.	Check that the monitor cable is fastened properly (for color monitors, check the green video cable connector).

(continued on next page)

Table 1-1 (Cont.). Visual Check Problems

Problem	Cause	Action
		Perform the extended self-tests described in Chapter 2.
		Replace the monitor.
The power indicator LED is dark and the fans are off.	Power cord is not connected properly.	Reconnect the power cord.
The power indicator LED is dark and the fans are off.	The power supply assembly is not functioning.	Replace the power supply assembly (see Chapter 3).
The fans start up but the LED stays dark.	Power supply assembly is not functioning.	Replace the power supply assembly (see Chapter 3.)

Shutting Down the Worksystem Software

Before running any diagnostic self-tests, shut down the worksystem software. If the worksystem software isn't running, skip this section and go to the Running the Power-Up Self-Test section in this chapter.

To shut down the worksystem software, log in to the ULTRIX field account or an account that has superuser privileges. Type one of the following at the system prompt (#):

Command	Result
<code>/etc/shutdown -h now</code>	This command starts the worksystem software shut down procedure immediately, without issuing warning messages.
<code>/etc/shutdown -h hhmm</code>	This command shuts down the worksystem software at a specified time. In this table, hh indicates hours, mm indicates minutes. The workstation sends warning messages to all users on the Local Area Network (LAN) indicating shut down time.
<code>/etc/shutdown -h +n</code>	This command shuts down the worksystem software after a specified number of minutes. In this table, n indicates the number of minutes after which the worksystem software shuts down. The workstation sends warning messages to all users on the LAN at an increasing frequency.

Running the Power-Up Self-Test

The power-up self-test checks each component, subsystem, and connection. The DECstation 2100/3100 automatically runs the power-up self-test and displays the console prompt (>>) when you turn on the workstation.

To turn on the workstation, push the on/off switch on the system unit to the on (I) position. Figure 1-1 shows the location of the system unit on/off switch.

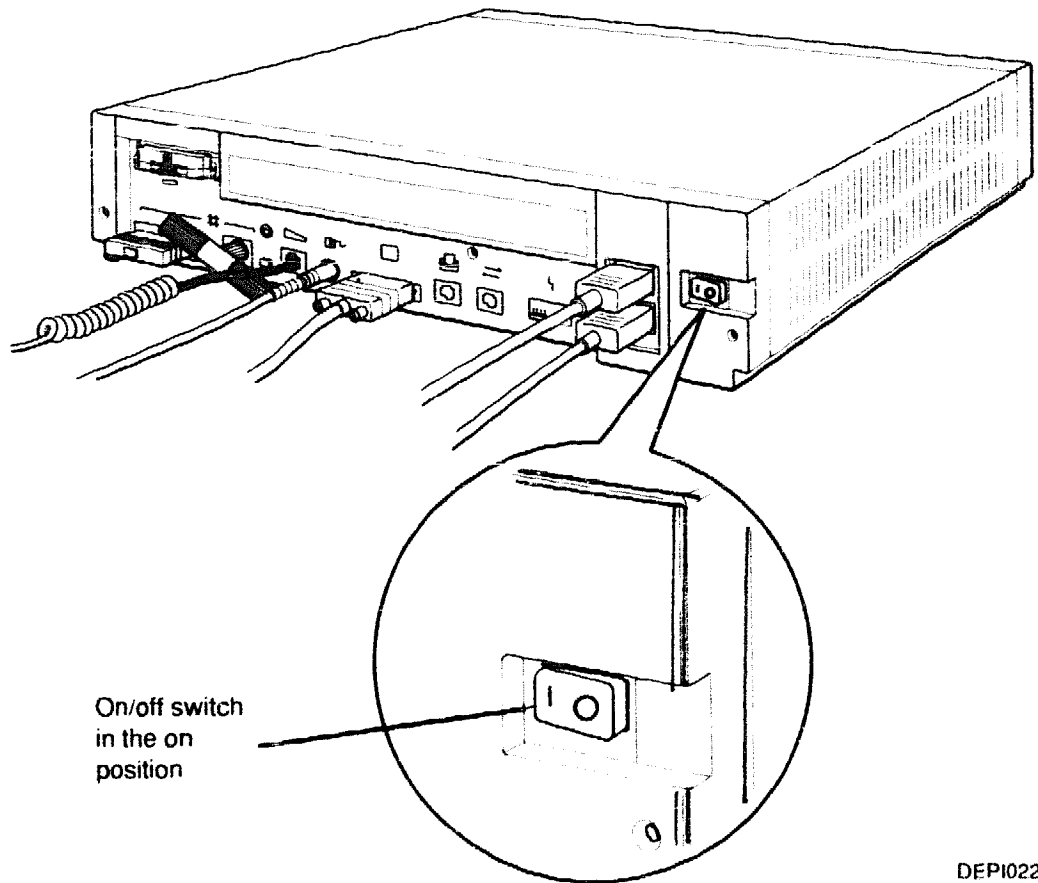

DEPI022

Figure 1-1. On/Off Switch

Figure 1-2 shows a typical power-up self-test display when it successfully completes.

```
KN01 V X7.0g
7..6..5..4..3..2..1..0
16Mb.....0
KN01 V X7.0g
08-00-2b-0c-4a-93
0x01000000
1) Dansk
2) Deutsch
3) Deutsch (Schweiz)
4) English
5) English (British/Irish)
6) Español
7) Français
8) Français (Canadian)
9) Français (Suisse Romande)
10) Italiano
11) Nederlands
12) Norsk
13) Português
14) Suomi
15) Svenska
16) Vlaams
(1..16):
```

Figure 1-2. Successful Power-Up Self-Test Display

Each number in the second line of the power-up self-test display corresponds to tests for specific hardware components. The third line shows the size of the workstation's memory. While the third line is being displayed, the workstation creates a bit map of all bad memory pages which is passed to the worksystem software. Then the rest of the display appears.

The fourth line in the display indicates the version of the system module console program. The fifth line contains the workstation's Ethernet address. The sixth line shows the size of memory in hexadecimal format. Numbers 1 to 16 are different languages from which you select the proper keyboard. At the prompt

(1..16):

type your keyboard language selection. The console prompt (>>) then appears.

Unsuccessful Power-Up Self-Test

If a power-up test fails after you initially turn on the workstation, the power-up self-test halts and two question marks (??) flash on the screen. Do the following:

1. Note the number of the test that failed. The last number displayed on the screen is the failed test. Refer to the **Interpreting Self-Test Results** section in this chapter to interpret this test.
2. Press the reset button located on the back of the system unit (see Figure 1-3). The power-up self-test stops again at the failed test. This typical screen display shows test 3 failed.

```
KN01  V  X7.0g
7..6..5..4..3..
??
```

At the console prompt (>>), you can run the self-test or type any other console command.

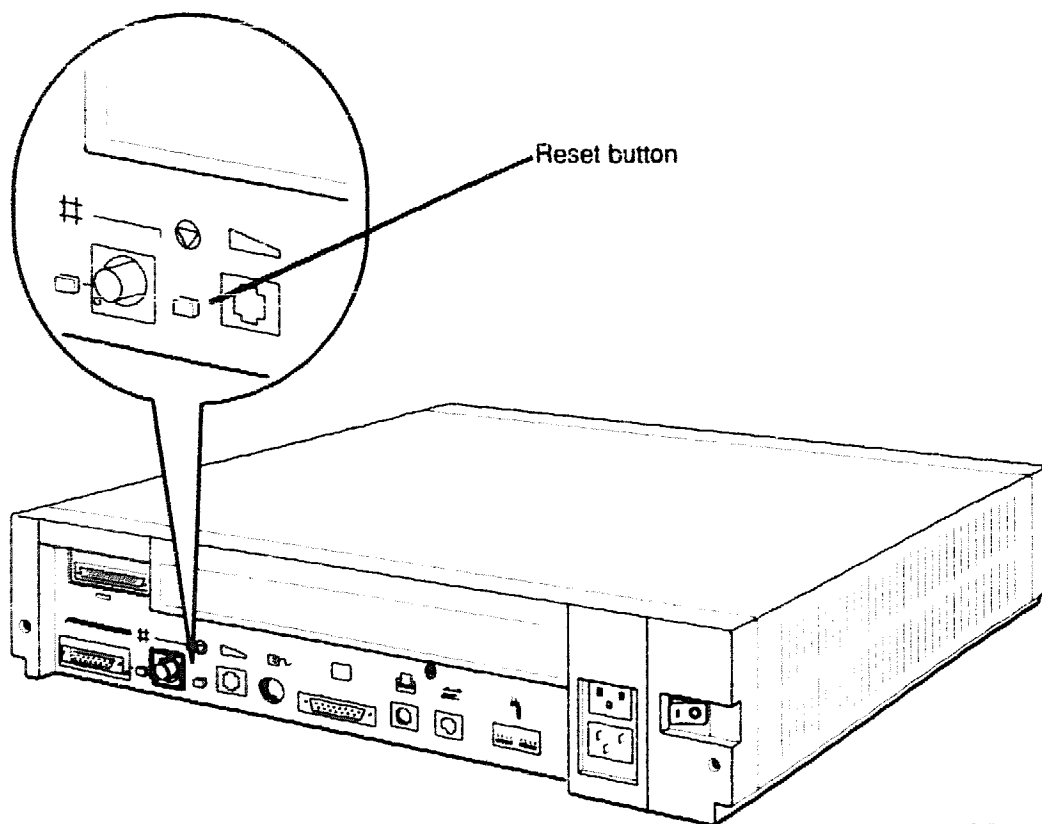

DEPM023

Figure 1-3. Reset Button

If the power-up self-test display does not appear on the monitor, use the status LED display to determine the problem. Figure 1-4 shows the location of the status LED display.

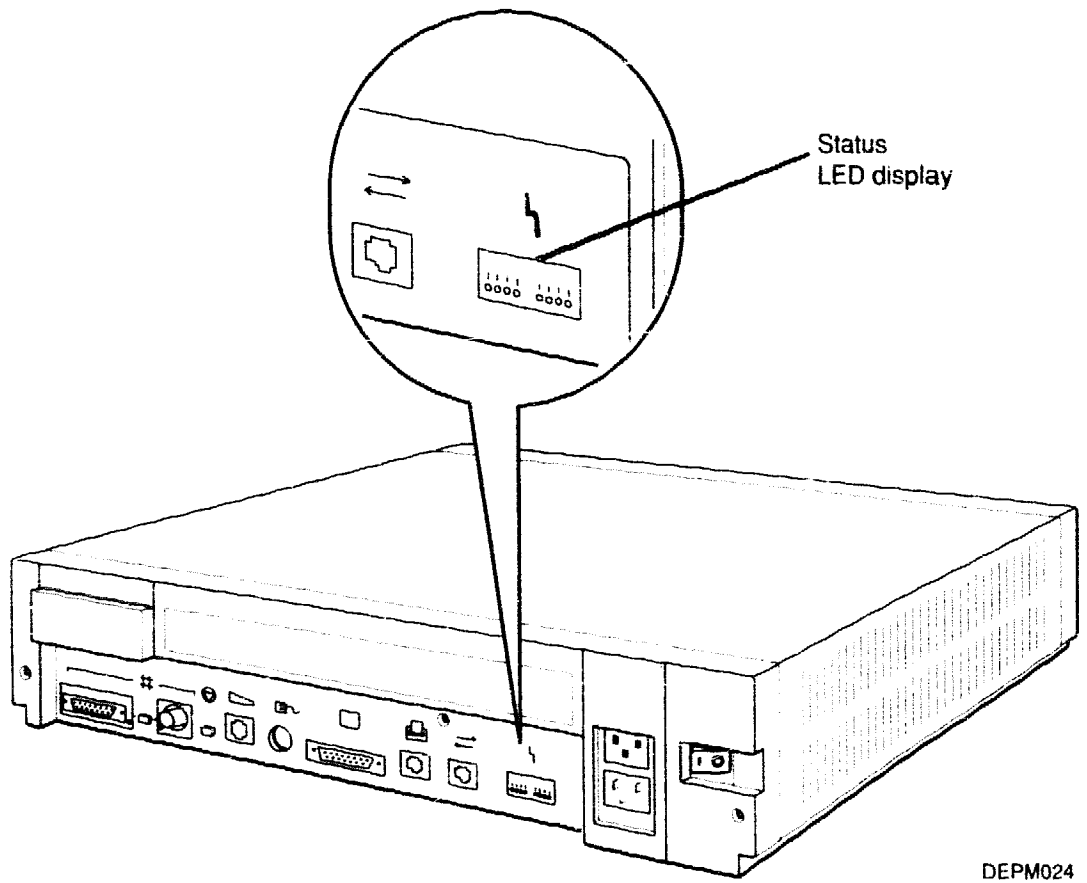

DEPM024

Figure 1-4. Status LED display

The LEDs are arranged in two groups of four and form a binary display. When you initially turn on the workstation, the DECstation 2100/3100 performs the power-up self-test and the LEDs blink accordingly. If an error is detected, the workstation halts on the LED code corresponding to the failed component. Note the configuration of the display. Refer to the Interpreting the Status LED Display section in this chapter to interpret the status LED codes.

Running the Self-Test

The self-test is similar to the power-up self-test, except you can run this test any time you are at console prompt. The self-test performs slightly more extensive tests and attempts to put any SCSI devices connected to the workstation on-line. To run the self-test:

1. Type (exactly):

test -a

You see the following power-up self-test display.

```
KN01  V  X7.0g
7..6..5..4..3..2..1..0
16Mb.....0
>>
```

If an error occurs during the hardware tests, the test stops and two question marks (??) appear. Follow the procedure described in *Unsuccessful Power-Up Self-Test*.

When the workstation completes the self-test, the console prompt appears.

Note: You can also use the reset button to run the self-test. If you use the reset button, the workstation performs the same hardware tests as is done during the power-up self-test; however, it does not perform any memory tests and the workstation will attempt to place recognized SCSI devices on line.

2. Note what test failed. When errors occur, testing stops at the test that failed. For example, if the testing stops following the display of test code 5, then test number 5 failed. Refer to the *Interpreting Self-Test Results* section in this chapter for details about interpreting the self-test.

If the monitor is not working, you can observe the status LED display during the self-test. If an error occurs, write down the LED display configuration that appeared. Refer to the *Interpreting the Status LED Display* section in this chapter to determine what component failed.

Interpreting Self-Test Results

This section describes how to interpret the power-up self-test and the self-test results.

If any test failed during the self-tests:

1. Check all external connections, cables, and power cords.
2. Make sure the mouse connector is seated properly, or if the workstation is a server, the mouse loopback connector is installed.

If you cannot locate an external problem, compare the code of the test that failed during the power-up self-test or self-test with those described in Table 1-2 and take the appropriate action. Refer to Chapter 2 for instructions about running the extended self-tests.

Table 1-2. Interpreting Test Codes

Test Code	Component Tested	Action
7	Video Single In-line Memory (Video SIM) module	Run the Video RAM extended self-test or replace the Video SIM module.
6	VDAC and PCC	Run the VDAC and PCC extended self-tests. Replace Video SIM module, the monitor-system cable, or system module.
5	DZ serial line	Run the DZ extended self-test or replace the system module.

(continued on next page)

Table 1-2 (Cont.). Interpreting Test Codes

Test Code	Component Tested	Action
4	System module	Check the SCSI cable and terminator. Run: <ul style="list-style-type: none">■ Cache extended self-test■ Color Mask extended self-test■ CSR extended self-test■ FPU extended self-test■ RTC extended self-test■ TLB extended self-test■ Write Buf extended self-test Replace the appropriate FRU.
3	Keyboard and Mouse	Run the keyboard or mouse extended self-tests. Replace the appropriate FRU.
2	Network Interface (LANCE)	Run the LANCE, Net RAM, and ESAR extended self-tests. Replace the appropriate FRU.
1	Disk	Run the Disk RAM and SII extended self-tests. Replace the appropriate FRU.
0	None, Test End Indicator	None

Interpreting the Status LED Display

Compare the LED codes you saw during the power-up self-test or self-test with those described in Table 1-3 and take the appropriate action.

Table 1-3. LED Power-Up Self-Test Display Codes

LED Display 1 = LED On	Hexadecimal Code	Component Tested	Action
0111 1111	7f	System Module	Replace the system module or run: -Cache extended self-test -Color Mask extended self-test -CSR extended self-test -FPU extended self-test -RTC extended self-test -TLB extended self-test -Write Buf extended self-test
1011 1111	bf	Disk	Run the SII extended self-tests or replace the system module.
1101 1111	df	Keyboard	Check keyboard connections and keys. Run the Keyboard extended self-test. Replace the keyboard
1110 1111	ef	Memory	Replace the first four Mbytes of memory (D SIM modules 1 and 2) and run the power-up self-test. If the power-up self-test fails again, replace the system module.
1111 0111	f7	Mouse	Check mouse connections and buttons. Replace mouse if necessary.
1111 1111	ff	LEDs set at Power up or Reset	Replace the system module.

Using the Console Menu

The Console menu lists the commands you can use while at the console prompt. Display the Console menu by typing the following at the console prompt and pressing the RETURN key:

?

Figure 1-5 shows the Console menu.

```
CMD:
  auto
  boot [-f FILE] [-n] [ARG...]
  cat FILE...
  ctrs
  d [-(b|h|w)] ADDR VAL
  disable DEV
  dump [-(b|h|w)] [-(o|d|u|x|c|B)] RNG
  e [-(b|h|w) ADDR
  enable DEV
  fill [-(b|h|w)] [-v VAL] RNG
  go [PC]
  help [CMD]
  ? [CMD]
  init
  printenv [EVAR...]
  setenv EVAR STR
  test [ARG...]
  unsetenv EVAR
  warm

RNG:
  ADDR#CNT
  ADDR:ADDR
>>
```

Figure 1-5. Console Menu

Console Command Conventions

Use the following conventions when typing console commands:

- All commands are *case sensitive*.
- Type any command *exactly* as it is on the Console menu, add the appropriate argument, and press the RETURN key.
- Type numeric values as:
 - Decimal - Decimal values are represented by a string of decimal digits with no leading zeros (for example, 123).
 - Octal - Octal values are represented by a string of octal digits with a leading zero (for example, 0177).
 - Hexadecimal - Hexadecimal values are represented by a string of hexadecimal digits preceded by 0x (for example, 0x3ff).
 - Binary - Binary values are represented by a string of binary digits preceded by 0b (for example, 0b1001).

The following sections describe each console command.

Note: *If you use CTRL/C to abort a command, use the **init** and **scsi rs** commands to reset the system before proceeding.*

Auto Command

This command starts the autoboot sequence that puts the workstation into multi-user mode (the normal time-sharing environment). The format for this command is:

auto

Once you start the autoboot sequence, the sequence delays for 5 seconds. During this delay, you can abort the bootstrap sequence by typing CTRL/C on the console. When you type the autoboot command, the workstation tries to boot according to the bootpath variable stored in the Environment Variables Table. Refer to the printenv command section in this chapter.

Boot Command

This command specifies a file from which the worksystem software is loaded. The format for this command is:

boot [-f FILE] [-n] [ARG...]

- The -f flag followed by the FILE parameter specifies the file you want to use during a boot procedure. If you do not specify the -f flag and a file, then the file specified by the environment variable, bootpath, is loaded. Refer to the printenv command section in this chapter.

The FILE parameter has the format:

device(controller,unit,partition)filename

- The device indicates the device from which you booting the worksystem software. Typical devices are rz for hard disk, tz for tape, mop for network booting.
 - The controller indicates the ID number of the default controller.
 - The unit indicates the unit number of the device from which you are booting the worksystem software.
 - The partition indicates the number of the partition from which you are booting the worksystem software.
 - The filename indicates the name of the worksystem software file.
- The -n flag indicates that the specified file is loaded but not executed.
 - The parameter, ARG, specifies any information to be passed to the booted image.

Ctrs Command

This command displays all the network counters. The format for this command is:

ctrs

A typical display looks like the following:

```
658 : secs
    0 : bytes rcv
  92 : bytes snt
    0 : frms rcv
    2 : frms snt
    0 : mc bytes rcv
    0 : mc frms rcv
    0 : frms snt dfrd
    0 : frms snt, =1 cllsn
    0 : frms snt, >1 cllsn
    0 : snd flrs
    0 : snd flr bmap
    0 : rcv flrs
    0 : rcv flr bmap
    0 : unkwn dest
    0 : data ovrn
    0 : unav sbuf
    0 : unav ubuf
```

Where,

secs	= seconds since zeroed
bytes rcv	= bytes received
bytes snt	= bytes sent
frms rcv	= frames received
frms snt	= frames sent
mc bytes rcv	= multicast bytes received
mc frms rcv	= multicast frames received
frms snt dfrd	= frames sent deferred
frms snt, =1 cllsn	= frames sent, single collision
frms snt, >1 cllsn	= frames sent, multiple collision
snd flrs	= send failures
snd flr bmap	= send failure bitmap
rcv flrs	= receive failures
rcv flr bmap	= receive failure bitmap
unkwn dest	= unrecognized destinations
data ovrn	= data overruns
unav sbuf	= unavailable system buffers
unav ubuf	= unavailable user buffers

D (Deposit) Command

This command deposits a single byte, halfword or word value at the specified address. The format for this command is:

d [-b | h | w] ADDR VAL

- The parameter, -b, indicates a single byte.
- The parameter, -h, indicates a halfword.
- The parameter, -w, indicates a word.
- The parameter, ADDR, indicates a virtual address. For example, to examine physical location 0, type **0x80000000**.
- The parameter, VAL, indicates a specific numeric value.

Disable Command

This command disables the connection to a specified device. It also removes the device from the list of recognized console terminals stored in volatile memory. The format for this command is:

disable DEV

The parameter, DEV, is the device you are disabling. The valid devices you can specify:

- **tty(n)**, where n indicates a serial line; 2 for the communications connector and 3 for the printer/console connector. For example, to disable an alternate console, you type:

disable tty(3)

- **crt(0)**, where 0 is the only valid number, indicating the workstation monitor.

If you do not specify a value, the current list of enabled console devices appears.

Dump Command

This command shows a formatted display of the contents of memory. The format for this command is:

dump [-(b | h | w)] [-(o | d | u | x | c | B)]RNG

- The parameter, -b, displays memory in bytes.
- The parameter, -h, displays memory in halfwords.
- The parameter, -w, displays memory in words.
- The parameter, -o, displays memory in octal format.
- The parameter, -d, displays memory in decimal format.
- The parameter, -u, displays memory in unsigned decimal format.
- The parameter, -x, displays memory in hexadecimal format.
- The parameter, -c, displays memory in ASCII format.
- The parameter, -B, displays memory in binary format.
- The parameter, RNG, indicates a range of memory. The values for this parameter are:
 - ADDR#CNT - displays a specified number of a values
 - ADDR:ADDR - displays all values between the specified addresses

E (Examine) Command

This command examines the byte, halfword, or word at a specified address. The format for this command is:

e [-(b | h | w)] ADDR

- The parameter, -b, indicates a single byte.
- The parameter, -h, indicates a halfword.
- The parameter, -w, indicates a word.
- The parameter, ADDR, indicates a virtual address. For example, to examine physical location 0, type **0x80000000**.

Enable Command

This command enables the connection to a specified device. It also adds the device to the list of current console devices stored in volatile memory. The format for this command is:

enable DEV

The parameter, DEV, is the device you are enabling. The valid devices you can specify:

- `tty(n)`, where `n` indicates a serial line; 2 for the communications connector and 3 for the printer/console connector. For example, to enable an alternate console, you type:

enable tty(3)

- `crt(0)`, where 0 is the only valid number, indicating the workstation monitor.

If you do not specify a value, the current list of enabled console devices appears. You can enable more than one device as a console device.

Fill Command

This command places a specified value in a range of memory. If you don't specify a value, the workstation puts zeros in the memory range. The format for this command is:

fill [-(b | h | w)] [-v VAL] RNG

- The parameter, `-b`, indicates bytes.
- The parameter, `-h`, indicates halfwords.
- The parameter, `-w`, indicates words.
- The parameter, `-v VAL`, specifies the numeric value you are placing in memory.
- The parameter, `RNG`, is the memory range. You can specify:
 - `ADDR#CNT` - a specified number of values are filled
 - `ADDR:ADDR` - all values between the indicated addresses are filled.

Go Command

This command transfers control to the indicated entry point address. The format for this command is:

go [PC]

The parameter, PC, is the entry point address you want to use.

If you do not specify an entry address, the workstation uses the entry point of the program module that was most recently loaded. If no program module was previously loaded, the workstation use 0 as the entry point address.

Help Command

This command displays the correct format for a specified command. The format for this command is:

help [CMD]

The parameter, CMD, is the command for which you need information. If no command is specified, the complete Console menu appears.

? Command

This command functions exactly like the help command. The format for this command is:

? [CMD]

The parameter, CMD, is the command for which you need information. If no command is specified, the complete Console menu appears.

Init Command

This command performs a full initialization. The format for this command is:

init

The effect of the **init** command is identical to turning the power on or pressing the reset button, except that the workstation does not execute the diagnostics.

Passwd Command

The password command, which is not available on all systems, allows you to use only the boot and password commands until you enter a password. A system that requires a password before you can use all console commands displays the prompt **s>** until you enter the correct password.

To be able to use all console commands on a system that requires a password, type **passwd** at the prompt **s>**. Then type the password and press Return. The system then allows you to use all console commands. Whenever all console commands are available, the system uses the prompt **>>**.

To set or change a password, use the password command with the **-s** option.

1. Type **passwd -s** at the prompt **>>** and press Return.
2. At the prompt **pwd:**, type the new password and press Return.
3. The system then repeats the prompt **pwd:**. Enter the password a second time at the prompt **pwd:**.

Note that passwords must

- Have at least six characters
- Have no more than 32 characters
- Use uppercase and lowercase letters the same as when you first entered the password

If the two password entries match, the entry becomes the new password. If the two entries do not match, the old password remains in effect.

To remove a requirement for a password, type **passwd -c** at the prompt **>>** and press Return.

Printenv Command

This command displays the current value for a specified environment variable. The format for this command is:

printenv [EVAR...]

The parameter, **EVAR**, is the variable whose value you want to see. If you do not specify a variable, the complete Environment Variable Table appears. Figure 1-6 shows an example of this table.

```
baud2=1200
baud3=9600
bootpath=
bootmode=*
console=0
kbd=4
scsiid0=6
systype=0x82011601
bitmap=0xa000fcc0
bitmaplen=0xc0
inetaddr=0
osconsole=1
```

Figure 1-6. Environment Variable Table

There are three types of variables, volatile (lost when power is interrupted), nonvolatile (maintained after power resumes), and fixed (rebuilt when power is turned on). Table 1-4 describes the default variables.

Table 1-4. Default Environment Variables

Variable	Type	Description
baud2	Nonvolatile	This variable shows the baud rate of the communications connector.
baud3	Nonvolatile	This variable shows the baud rate of the printer/console connector.
bootpath	Nonvolatile	This variable shows the default boot path. The workstation uses this variable when you type the auto command.
bootmode	Nonvolatile	<p>This variable shows the mode in which the workstation is placed when it is turned on or reset. Use a one-character code to specify the bootmode. The bootmode codes you can use are:</p> <ul style="list-style-type: none">■ * - Default; stops the workstation at the console prompt.■ a - Automatically boots the workstation after power is turned on or workstation is reset; uses the bootpath variable.■ d - Resets the workstation without running diagnostics.■ r - Restarts the workstation.

(continued on next page)

Table 1-4 (Cont.). Default Environment Variables

Variable	Type	Description
console	Nonvolatile	<p>This variable shows which device is used for the console when the workstation is started. Use a single numeric character to set the value of this variable. The most common values for the console are:</p> <ul style="list-style-type: none">■ 0 - The workstation determines the correct device and sets the value in the <code>osconsole</code> variable.■ 1 - Enables the workstation monitor, <code>crt(0)</code>, and the keyboard, <code>tty(0)</code>.■ 4 - Enables the communications connector device, <code>tty(2)</code>.■ 8 - Enables the printer/console connector device, <code>tty(3)</code>.■ 9 - Enables the workstation monitor, <code>crt(0)</code>, the keyboard, <code>tty(0)</code>, and the printer/console connector device, <code>tty(3)</code>.
kbd	Nonvolatile	<p>Contains the keyboard code. A total of 16 different keyboard codes are supported. Valid values are 1 to 16.</p>
scsiid0	Nonvolatile	<p>Contains the SCSI ID of the processor. Valid values are 0 to 7. Values other than the default (6) are needed only for unusual SCSI bus configurations.</p>
systype	Fixed	<p>This variable shows a value taken from the hardware register in the CPU. Do not change this variable.</p>
bitmap	Fixed	<p>This variable shows the address of the memory bitmap. The bitmap is a vector of words. Each bit in a word corresponds to a page in memory. If the bit is set to 1, the page is good and available to memory. If the bit is set to 0, the page is bad. Do not change this variable.</p>

(continued on next page)

Table 1-4 (Cont.). Default Environment Variables

Variable	Type	Description
bitmaplen	Fixed	This variable shows the length of the memory bitmap. Do not change this variable.
inetaddr	Volatile	This variable is the workstation's internet address and is used by the Ethernet driver.
osconsole	Volatile	This variable indicates which device the workstation selected to be the console when the workstation was turned on. The value for this variable is indicated by a single numeric character. For example, if the console variable is set to 0 and the workstation selects the workstation monitor to be the console, the osconsole value is set to 1.

Setenv Command

This command assigns new values to the specified variable. Refer to the printenv command in this chapter for a description of each variable. The format for this command is:

setenv EVAR STR

- The parameter, **EVAR**, is the variable you want to set.
- The parameter, **STR**, is the value you want to specify.

You can add your own environment variables. These variables are stored in volatile memory. The Environment Variables Table can contain up to 16 variables, a total of 256 characters. Refer to Table 1-4 for a description of each variable.

Test Command

This command allows you to run the self-test or display the current configuration table. The format for this command is:

test [ARG...]

The parameter, ARG, can be:

- **-a**

Using this argument with the test command runs the self-test. The self-test is similar to the power-up self-test. Refer to the Running the Self-Test section in this chapter for more details.

- **-c**

Using this argument with the test command displays the configuration table. The configuration table provides information such as how much memory is installed, whether a monochrome or color Video SIM module is part of your workstation, and what kind of disk and/or tape storage device is connected.

Figure 1-7 on the next page shows a typical configuration table.

```

MEM: 16Mbytes
VIDEO: MONO
ETHERNET STA ADDR: 08-00-2b-0c-4a-8b
SCSI DEVS:
U[7]
U[6] KN01--SII
U[5]
U[4]
U[3] Dev typ 0 RZ
      RMB          0x0
      Vrs          1
      Format       1 CCS
      Add len     31
      Vndr        DEC
      PID         RZ23      (C) DEC
      Frevlvl     0618

U[2]
U[1]
U[0]

```

Figure 1-7. Sample Configuration Table

Where,

```

ETHERNET STA ADDR: = ETHERNET STATION ADDRESS:
SCSI DEVS:         = SCSI DEVICES:
U[7]               = Unit[7]
U[3] Dev typ 0 RZ = Unit[3] Device type 0 DISK
Vrs                1 = Version                1
Format            1 CCS = Response data format 1 CCS
Add len           31 = Additional length      31
Vndr              DEC = Vendor                DEC
PID              RZ23 = Product identification RZ23 (C) DEC
Frevlvl           0618 = Firmware revision level 0618

```

Unsetenv Command

This command removes the specified variable from the Environment Variables Table. The format for this command is:

unsetenv EVAR

The parameter, **EVAR**, is the variable you are removing. Refer to Table 1-4 for a description of each variable.

The environment variables stored in nonvolatile memory are not affected.

Warm Command

This command restarts the workstation without performing the complete bootstrap procedures. This feature is not currently supported by ULTRIX and is reserved for future use.

Using the SCSI Menu

The SCSI menu lists commands you can use for tests involving the SCSI connector and supported devices.

SCSI Test Levels

SCSI tests can be run in different modes for different audience levels to satisfy specific diagnostic requirements. These are the SCSI test modes and audience levels:

1. User Mode

a. Confidence Tests

- These are go/no-go tests.
- Tests do not harm the customer operating environment.
- Tests are run on power-up.
- Tests operate at chip-level for SCSI.
- No external peripherals are tested on power-up.

b. Warm Reset

- Tests are initiated when the RESET button is pressed (after power-up).
- Peripherals are tested in self-test mode.
- Executes non-destructive tests to all recognized DEC peripherals.
- Removable media devices do not require media or test fixtures.

2. Manufacturing Mode

- a. Audience - Manufacturing line personnel, repair depot technicians, etc.
- b. Also run on new installations as a means of gaining confidence in the functionality of peripherals.
- c. Tests are more exhaustive and destructive on all peripherals that support write tests.

3. Extended Mode Self-Tests

- a. Audience - Field service.
- b. Tests are restricted to DEC peripherals only.
- c. Tests are non-destructive and permit reading and writing (on write devices).
- d. Tests are done on reserved diagnostic tracks that are not accessible to users.
- e. All removable media devices require blank media.
- f. Read-only devices require pre-recorded test media.

4. SCSI Extended Self-Tests

- a. Audience - Field service, repair depot technicians, and new peripheral/system installations.
- b. Tests assume that the operator has some familiarity with SCSI protocol.
- c. Tests are restricted to DEC peripherals only.
- d. All commands that exercise peripherals are destructive.
- e. SCSI Tests:
 - **t1, t2, t3** - Tests all onboard functionality of the SCSI controller chip and circuitry.
 - **t4** - Tests data path to the SCSI edge connector. Requires a loopback connector.
 - **ex** - A non-destructive method for getting a full functional check of a peripheral device.

Note: In the example display, shown in Figure 1-8, the command descriptions are NOT displayed on the screen. The descriptions are presented here for clarification.

Display the SCSI menu, shown in Figure 1-8, by typing:

scsi ?

```

-046-0b HELP
SCSI a1  a2  a3

pb          Probe for and setup all units
rs          Reset the SCSI bus
ri          Reset the SII chip
st          Dump the SCSI status registers
de          Disable SCSI bus drivers
du          Dump all SCSI registers
cd  unit [r] Read/write test for SCSI hard drive
cf  unit [r] Read/write test for SCSI floppy
ct  unit [r] Read/write test for TK50Z tape drive
cr  unit [r] Read only self test for RRD40 ROM disc drive
fm  unit          Format <unit> using default parameters
ex  unit [r]      Execute DEC extended mode self-test
iq  unit          Show inquiry response from <unit>
ms  unit          Show mode sense response from <unit>
ry  unit          Show READY status for <unit>
sn  unit          Show request sense response from <unit>
sp  unit          Stop <unit>
sr  unit          Start <unit>
su  unit          Set up unit wait for ready status
t1  [r]          SII buffer port memory response
t2  [r]          SII target mode internal loopback test
t3  [r]          SII initiator mode internal loopback test
t4  [r]          SII external drive loopback required!

```

Figure 1-8. SCSI Menu

To type SCSI commands at the console prompt, use the format:

scsi arg1 [arg2] [arg3]

The second argument is either a unit number or the optional repeat argument [r]. To find the unit number of a specific device, use the test -c command or the SCSI command, pb. In the examples in this guide, the word, **<unit>**, indicates that you type a number (not the word unit).

The third argument of the SCSI command line can also be the repeat argument, depending on the specific command format. Table 1-5 describes the SCSI commands.

Note: If you use CTRL/C to abort a SCSI command, use the *init* and *scsi rs* commands to reset the system before you proceed.

Table 1-5. SCSI Commands

Command	Description
pb	This command polls the workstation and lists all the SCSI devices currently recognized by the workstation. The format for this command is: scsi pb . See the Viewing the SCSI Storage Device Listing section in Chapter 2.
rs	This command resets the SCSI bus and any peripherals. The format for this command is: scsi rs . This command should be used by experienced users and service/repair personnel only.
ri	This command does an internal reset of the SII chip and is used to rs and service/repair personnel only.
ri	This command does an internal reset of the SII chip and is used to recover from a locked up SII without resetting the external bus. This command is NOT for field use.
st	This command displays all status registers of the SII. The SII is the LSI chip used by the SCSI bus. The format for this command is: scsi st . <i>For Manufacturing Use.</i>
de	Disable SCSI bus drivers.
du	This command displays the state of all SII registers. The command format is: scsi du . <i>For Manufacturing Use.</i>
cd	This command runs the Canned Disk Test. The format for this command is: scsi cd <unit> [r] . Refer to Chapter 2 for more details.
cf	This command runs the Canned Floppy Disk Test. The format for this command is: scsi cf <unit> [r] . Refer to Chapter 2 for more details.
ct	This command runs the Canned Tape Test (requires a blank tape). The format for this command is: scsi ct <unit> [r] . Refer to Chapter 2 for more details.
cr	This command runs the Canned CDROM Disc Drive Test (requires a test disc). The format for this command is: scsi cr <unit> [r] . Refer to Chapter 2 for more details.
fm	This command formats and initializes a floppy disk in 18 sector/track HD mode. Use system utilities for other devices. You are asked to confirm the operation before the initialization takes place. The format for this command is scsi fm <unit> .

(continued on next page)

Table 1-5 (Cont.). SCSI Commands

Command	Description
ex	This command instructs only Digital peripherals to do an extended self-test. This test is limited to DEC peripherals and does not destroy user data areas. It writes on diagnostic tracks of non-removable media devices. Blank or test media is required for removable media devices. The format for this command is scsi ex <unit> .
iq	This command performs an inquiry about a specified unit. It displays information about the SCSI device (type 0 = hard disk drive and type 1 = magnetic tape drive, type 5 = compact disk drive), the format, additional bytes of inquiry data available for a device, and the firmware version. The format for this command is: scsi iq <unit> .
ms	This command provides detailed information about the attributes of a device. The information this command displays includes the device's geometry, whether the device has removable media, drive features, and vendor-supplied data. To interpret data categories and values, refer to the device's specification. The format for this command is: scsi ms <unit> . <i>For Manufacturing Use.</i>
ry	This command indicates whether a specified device is ready. The format for this command is: scsi ry <unit> .
sn	This command is a SCSI request sense command and provides additional information about a SCSI device that fails an extended self-test. Issue this command directly after the device fails. If you issue another command that performs an inquiry of the failed device, you may lose the sense data. The information this command displays includes values and error messages for the data categories of sense key and FRU. It also displays vendor-supplied data. To interpret data categories and values, refer to the ANSI specification for the SCSI bus, document number, x3.131-198-x. specification. The format for this command is: scsi sn <unit> . <i>For Manufacturing Use.</i>
sp	This command stops a specified device. The format for this command is: scsi sp <unit> .
sr	This command starts a specified device. The format for this command is: scsi sr <unit> .

(continued on next page)

Table 1-5 (Cont.). SCSI Commands

Command	Description
su	This command checks if the specified device is ready. If the device is not ready, the workstation tries to bring it on line. If this fails, the workstation displays an error message. The format for this command is: scsi su <unit> .
t1	This command runs the SCSI t1 test. The format for this command is: scsi t1 [r] . Refer to Chapter 2 for details.
t2	This command runs the SCSI t2 test. The format for this command is scsi t2 [r] . Refer to Chapter 2 for details.
t3	This command runs the SCSI t3 test. The format for this command is: scsi t3 [r] . Refer to Chapter 2 for details.
t4	This command runs the SCSI t4 test. The format for this command is: scsi t4 [r] . Refer to Chapter 2 for details.

Booting the Worksystem Software

After you finish running diagnostics or replacing FRUs, boot the worksystem software.

- If booting the workstation to multi-user mode (for a normal time-sharing environment), type:

auto

The workstation uses the bootpath environment variable stored in nonvolatile memory.

- If booting the workstation to single-user mode (only root partition mounted), type:

boot

The workstation uses the bootpath environment variable stored in nonvolatile memory.

- If booting the workstation to single-user mode from a server on the network, type:

boot -f mop()

Booting a standalone workstation from disk takes approximately 3 minutes. If you boot the worksystem software successfully, the workstation prompts you to log in.

***Note:** Some system drives contain factory-installed software. If you replace a drive that contains factory-installed software, the customer is responsible for replacing any software that was on the old drive.*

Unsuccessful Worksystem Software Boot

If the worksystem software does not boot successfully:

1. Allow the drive that attempted the boot to become accessible, then use the init command to initialize the system before attempting to reboot.
2. Use the printenv command to display the Environment Variables Table. Check the bootmode and bootpath variables.

3. Use the `setenv` command to set the `bootpath` variable to boot the worksystem software from the hard disk or the network.
4. Boot the worksystem software using the `boot` command.
5. If you still cannot boot the worksystem software, talk to the system manager.

Extended Self-Tests

Overview

This chapter describes how to run and interpret the DECstation 2100/3100 extended self-tests. You can run two types of extended self-tests; console and SCSI tests.

Note: Status and error messages are listed and described in Appendix D. Probable FRUs are included in the error-code lists.

Console Extended Self-Tests

Run console extended self-tests to diagnose component and subsystem malfunctions within the system unit. Tables 2-1 through 2-2 list all the extended self-tests and where you can find their descriptions in this chapter.

In most cases, you use a monitor to run and display extended self-tests. If the monitor is not working, you can observe the status LEDs to get the test results. Refer to the Running Extended Self-Tests Without a Functioning Monitor section in this chapter for instructions about using the status LED display.

You can run these tests in several different modes, depending on the type of information you want. The test modes are described in Table 2-3.

Table 2-1. Console Extended Self-Tests

Test Name	Test Command	Components Tested	Section
System Test	t a	All components and major subsystems	System Test
Memory Report	t b	D SIM modules	Memory Report
Color mask	t C	Color mask, Video SIM module	Color Mask Test
Cache	t c	Instruction and data caches	Cache Test
DZ	t D	Serial line interface	DZ Test
Disk RAM	t d	Disk memory buffer	Disk RAM Test
ESAR	t e	Ethernet Station Address ROM (ESAR)	ESAR Test
FPU	t F	Floating Point Unit	FPU Test
Video Test Patterns	t f	Video SIM module and VDAC	Video Test Patterns Test
Keyboard	t k	Keyboard	Keyboard Test
LANCE	t L	Network Interface	LANCE Test
LEDs	t l	Status LEDs	LEDs Test
Mode	t M	Sets test mode	Selects test modes
Main RAM	t m	Main memory buffer	Main RAM Test
Net RAM	t n	Network memory buffer	Net RAM Test
Mouse	t P	Mouse	Mouse Test
PCC	t p	Programmable Cursor Chip	PCC Test
CSR	t R	Control/status register	CSR Test
RTC	t r	Real-time Clock/battery-backed up RAM	RTC Test
SII	t s	SCSI buffer and interface	SII Test

(continued on next page)

Table 2-1 (Cont.). Console Extended Self-Tests

Test Name	Test Command	Components Tested	Section
TLB	t t	R2000 interface translate lookaside buffer	TLB Test
VDAC	t V	Video SIM module and system module	VDAC Test
Video RAM	t v	Video SIM module	Video RAM Test
Write Buf	t w	R2000 interface to main memory and write error address register	Write Buf Test

SCSI Extended Self-Tests

Run the SCSI extended self-tests to isolate faults with the SCSI bus, drivers, connections, or devices. Table 2-2 lists the SCSI tests and where you can find their descriptions in this manual.

Table 2-2. SCSI Extended Self-Tests

Test Name	Test Command	Components Tested	Test Section
Canned Disk	scsi cd	Hard disk drive	Canned Disk Test
Canned Disk	scsi cf	Floppy disk drive	Canned Floppy Disk Test
Canned Tape	scsi ct	Magnetic tape drive	Canned Tape Test
Canned CDROM Disc	scsi cr	Compact disc drive (Requires test disc.)	Canned CDROM Disc Test
Extended Mode Self-Test	scsi ex	Digital peripherals	Extended Self-Test
t1	scsi t1	SCSI disk buffer	t1—SII Buffer Test
t2	scsi t2	SII chip level support for target mode	t2—SII Target Mode Test
t3	scsi t3	SII chip level support for initiator role	t3—SII Initiator Mode Test
t4	scsi t4	SCSI drivers and connections	t4—SCSI Loopback and External Drive Tests

Diagnostic Aids

This section describes tools you can use when trying to isolate DECstation 2100/3100 hardware faults.

Diagnosing Intermittent Failures

If the workstation you are testing is experiencing intermittent errors, examine the ULTRIX error logs before running extended self-tests. You can use the ULTRIX tools, uerf and netstat, to trace some hardware errors. Refer to Section 8 in the ULTRIX documentation set for details about uerf and Section 1 for details about netstat. You can also refer to the *Troubleshooting Commands for ULTRIX-32 Field Service Pocket Reference Card*.

Connecting an Alternate Console

If your system does not display error codes, refer to Running Extended Self-Tests Without a Functioning Monitor. That section will help you to interpret the error codes by using the LED displays. For more information on SCSI troubleshooting, refer to SCSI Extended Self-Tests Troubleshooting.

You can type the DECstation 2100/3100 console commands from an alternate console through the printer/console connector located at the back of the system unit. When you connect an alternate console and enable the correct serial line, the same text that appears on the DECstation 2100/3100 monitor appears on the alternate console. If using a terminal as an alternate console, you can use either the DECstation 2100/3100 keyboard or the alternate console keyboard to type commands. Figure 2-1 shows the printer/console connector location.

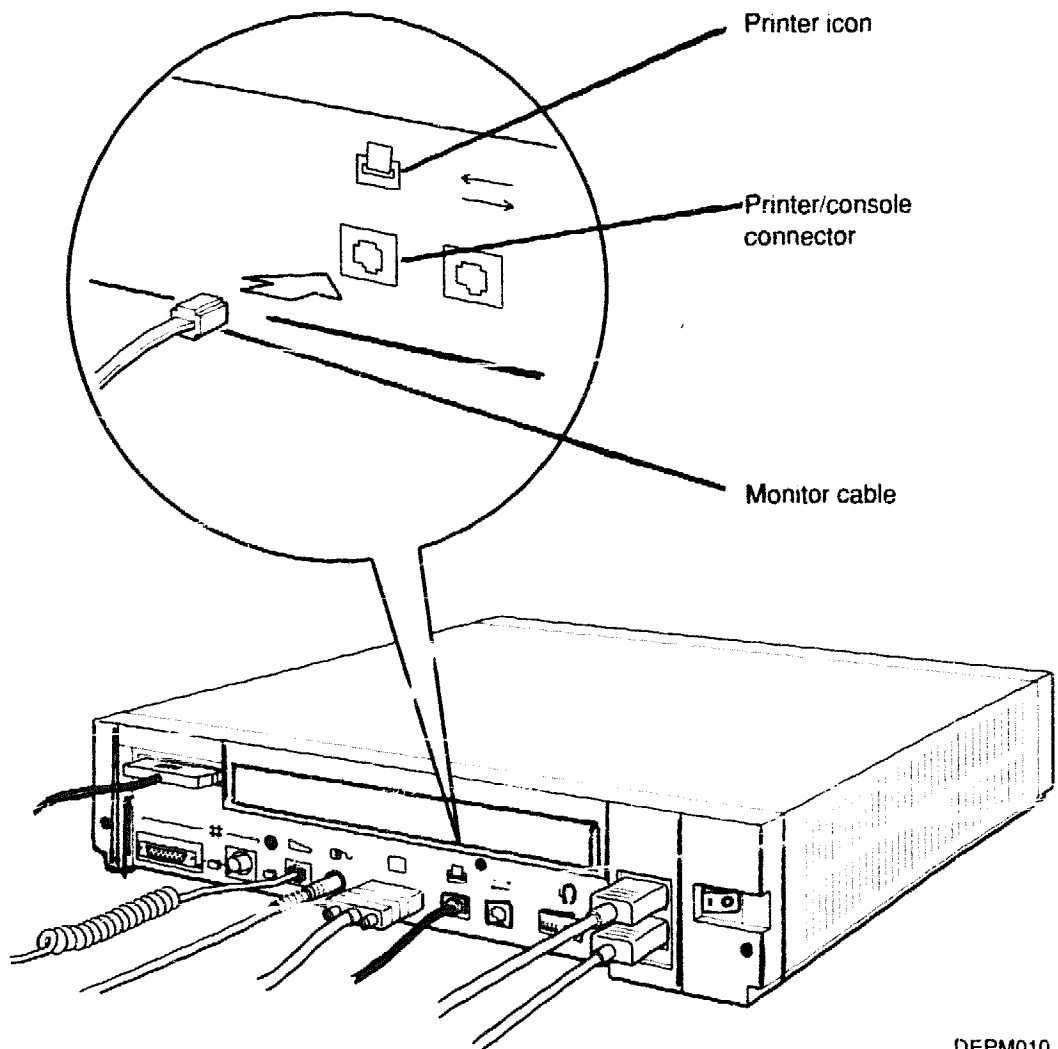

DEPM010

Figure 2-1. Printer/Console Connector Location

To connect an alternate console or printer to the DECstation 2100/3100, do the following:

1. Plug the external device (terminal or printer) into the connector closest to the video monitor cable. Note that this connector requires a modified modular jack (this jack looks like a regular phone connector, except that the tab is offset).
2. Using the original console, type:

enable tty(3)

Preparing for Console Extended Self-Tests

Before running the extended self-tests:

1. View the menu (test menu) to find the correct commands (refer to the Viewing Test Commands section in this chapter).
2. Select the appropriate test modes (refer to Selecting Test Modes).
3. Install terminators or loopback connectors for the test mode you are using (refer to the Terminating Connectors section in this chapter).

Viewing Test Commands

To view a menu listing all valid diagnostic options, type:

t ?

The workstation displays the menu shown in Figure 2-2.

Note: *In the example display in Figure 2-2, the command descriptions are NOT displayed on the screen. The descriptions are presented here for clarification.*

t	a1	a2	
	a	[r]	system test
	b		memory report
	C	[r]	color mask
	c	[r]	cache
	D		dz
	d	[r]	disk ram
	e	[r]	esar
	F	[r]	fpu
	f		video test patterns
		b	blue
		c	color bars
		e	E's
		g	green
		r	red
		w	white
		x	grid
	k		keyboard
	L	[r]	lance
	l	[r]	leds
	M		mode
		d	display modes
		h	toggle halt test on error
		l	toggle loop on error
		m	manufacturer/debug mode
		u	user mode
	m	[r]	main ram
	n	[r]	net ram
	P		mouse
	p	[r]	pcc
	R	[r]	csr
	r	[r]	rtc
	s	[r]	sii
	t	[r]	tlb
	V	[r]	vdac
	v	[r]	video ram
	w	[r]	write buf

Figure 2-2. Diagnostic Options Menu

Selecting Test Modes

Do the following:

1. To see the currently set modes, type:

t M d

You see a display similar to the following:

```
usr mod
no lp on err
hlt tst on err
```

Where,

```
usr mod           = user mode
no lp on err      = no loop on error
hlt tst on err    = halt test on error
```

Note: *The default modes are User, No Loop On Error, and Halt Test On Error.*

2. Specify test modes by typing the following at the console prompt:

t M arg

arg indicates you must type a specific argument. Arguments are single uppercase or lowercase alphabetic characters. They are separated from the rest of the command line (and any other arguments) with a space character.

The modes you can select and the arguments you type on the command line are described in Table 2-3.

Table 2-3. Test Modes

Mode Name	Argument	Description
[No]Halt On Error	h	The command for this mode toggles Halt On Error off and on. When set to Halt On Error, the diagnostic test sequence stops as soon as an error is detected and reports the error immediately. The remaining tests in the sequence are not run. Use this to save time when you expect an error to occur early on in the test sequence. This is the default mode when the workstation is turned on.
[No]Loop On Error	l	The command for this mode toggles Loop On Error on and off. When set to Loop On Error, the diagnostic procedure runs again as soon as an error is detected. This mode is designed for debugging hardware components using an oscilloscope in a manufacturing environment. The default mode when the workstation is turned on is No Loop On Error.
Manufacturer/Debug	m	This mode runs the most detailed check of all components. Some of the tests can destroy data on customer media. Select this mode if the User mode diagnostics fail to isolate a fault.
User	u	This mode performs a fast check of the workstation. It is a less comprehensive hardware check than that performed in Manufacturer/Debug mode. This mode reports hard, gross errors. This is the default mode when the workstation is turned on.

Terminating Connectors

Depending on the mode in which you run the diagnostics, you might need to install terminators or loopback connectors for the DECstation 2100/3100 connectors. Table 2-4 describes what terminators and loopback connectors to install for User and Manufacturer/Debug modes. Appendix B lists the terminator and loopback connector part numbers.

Table 2-4. Test Mode Terminators

Test Mode	Required Terminators/Loopback Connectors
User	A mouse or mouse loopback connector A keyboard A ThinWire Ethernet terminator, ThickWire Ethernet loopback connector, or connection to Ethernet cable (make sure the Ethernet button is in the proper position) A SCSI terminator
Manufacturer/Debug	A keyboard A mouse loopback connector (except when running the mouse test) A ThinWire Ethernet terminator, ThickWire loopback connector, or connection to Ethernet cable (make sure the Ethernet button is in the proper position) A SCSI terminator if a SCSI device is installed A SCSI loopback connector for the SCSI t4 test. Serial line loopback connectors for the communications and printer/console connectors

Refer to the *DECstation 2100/3100 Hardware Installation Guide* for instructions about installing terminators.

Installing the Internal SCSI Loopback Connector

When running the SCSI t4 test, install a SCSI loopback connector in the system unit SCSI connector. Do the following to install an internal SCSI loopback connector:

- Remove the system unit cover (refer to the Removing the System Unit Cover section in Chapter 3 for instructions).
- Disconnect the SCSI cable from the system module by pushing the SCSI connector latches in opposite directions. This releases the SCSI cable from the system module.

- Insert the SCSI loopback connector into the system unit SCSI connector. Make sure the side marked Side 1 is facing the rear of the system unit. This ensures that the pins on the loopback connector are properly aligned in the system module SCSI connector.

Note: *It is possible to insert the connector offset by two pins. Be sure that the connector covers all pins.*

Running Console Extended Self-Tests

To run a console extended self-test, type the appropriate command at the console prompt in the format:

t arg1 [arg2]

Although all tests run in either User or Manufacturer/Debug mode, this chapter uses only User mode test displays.

For most tests, you can select the repeat option by typing **r** as the second argument on the command line. Typing this argument causes the selected test to continue to repeat. To exit a repeating test, press any key.

Note: It may take several minutes for the test to halt.

If an error occurs during any console extended self-test, a message similar to the following appears:

```
?0d1-00 MSE - slf tst
```

When errors occur, check the appropriate field-replaceable unit (FRU). Refer to Chapter 3 for instructions for replacing the DECstation 2100/3100 Base System FRUs.

Note: Status and error messages are listed and described in Appendix D. Probable FRUs are included in the error-code lists.

*Note: If you use CTRL/C to stop a test, always use the **init** and **scsi rs** commands to reset the system before proceeding.*

System Test

The System Test checks all of the DECstation 2100/3100 components, subsystems, and connections.

To run the System test, type:

t a

Messages appear for each test. Refer to the individual test descriptions in this chapter for sample test displays.

Error code descriptions and probable FRUs are listed in Appendix D. Refer to Chapter 3 for instructions about replacing the FRUs.

Memory Report

The Memory Report displays the Memory Bad Page Table. It indicates the number of the dynamic RAM single in-line memory (DIMM) modules that failed.

To display the Memory Report table, type:

t b

A display similar to the one shown in Figure 2-3 appears.

```
16Mb
SIMM 7-8 = 0
SIMM 5-6 = 0
SIMM 3-4 = 0
SIMM 1-2 = 0
```

Figure 2-3. Sample Memory Report Display

Error code descriptions and probable FRUs are listed in Appendix D. Refer to Chapter 3 for instructions about replacing the FRUs.

Note: Although the Help display for this command may indicate that the Memory Report offers the repeat option, it does not.

Note: If the bootmode = d and the bitmap becomes corrupted, the bitmap is not regenerated.

Color Mask Test

The Color Mask test checks the color mask and the Video SIM module.

To run the Color Mask test, type:

t C

A display similar to the one shown in Figure 2-4 appears.

```
-05c-00 colr pln msk tst
```

Figure 2-4. Sample Color Plane Mask Test Display

Error code descriptions and probable FRUs are listed in Appendix D. Refer to Chapter 3 for instructions about replacing the FRUs.

Cache Test

The Cache test:

- Checks the instruction and data caches using data patterns.
- Verifies that Ksegs behave properly.
- Verifies that the instruction and data caches are loaded on instruction fetches and that the caches are used when valid.

To run the Cache test, type:

```
t c
```

A display similar to the one shown in Figure 2-5 appears.

```
-001-00 chk data cache ram w/pats  
-002-00 chk instruction cache ram w/pats  
-003-00 cache seq tst  
-004-00 chk inst cache  
-005-00 i cache tag tst  
-005-01 d cache tag tst  
-005-02 i cache tag parity tst  
-005-03 d cache tag parity tst  
-005-04 i cache data parity tst  
-005-05 d cache data parity tst  
-005-06 i cache valid bit tst  
-005-07 d cache valid bit tst
```

Figure 2-5. Sample Cache Test Display

Error code descriptions and probable FRUs are listed in Appendix D.

Refer to Chapter 3 for instructions about replacing the FRUs.

DZ Test

The DZ test does the following depending on the test mode you selected:

Mode	Test
User	Runs an internal loopback test at one baud rate, testing all serial lines except the keyboard connector.
Manufacturer/Debug	Runs an external loopback test, using all baud rates and lines. It also runs single and mixed SILO tests (DZ chip first-in, first-out tests), SILO overflow, SILO alarm test, and Data Terminal Ready/Data Set Ready loopback tests. This test does not perform an external loopback test of the keyboard connector.

To run the DZ test, type:

t D

Note: You cannot specify the repeat (*r*) argument for this test.

A display similar to the one shown in Figure 2-6 appears.

```
-01c-00 dz ln 00 int rx/tx lpback tst
-01c-00 dz ln 01 int rx/tx lpback tst
-01c-00 dz ln 02 int rx/tx lpback tst
-01c-00 dz ln 03 int rx/tx lpback tst
-01d-00 dz silo alarm tst
```

Figure 2-6. Sample DZ Test Display

Where,

```
dz ln 00 int rx/tx lpback tst
= dz all line 00 internal receive/transmit
  loopback test
```

Error code descriptions and probable FRUs are listed in Appendix D.

Refer to Chapter 3 for instructions about replacing the FRUs.

Disk RAM Test

The Disk RAM test writes and reads data patterns into the disk memory buffer.

To run the Disk Ram test, type:

```
t d
```

A display similar to the one shown in Figure 2-7 appears.

```
-02a-00 wrt dram w/ 0000  
-02a-00 chk dram w/ 0000  
-02b-00 wrt dram w/ 5555  
-02b-00 chk dram w/ 5555  
-02c-00 wrt dram w/ aaaa  
-02c-00 chk dram w/ aaaa  
-02d-00 wrt dram w/ ffff  
-02d-00 chk dram w/ ffff  
-02e-00 wrt dram w/ inc pat  
-02e-00 chk dram w/ pat
```

Figure 2-7. Sample Disk RAM Test Display

Error code descriptions and probable FRUs are listed in Appendix D. Refer to Chapter 3 for instructions about replacing the FRUs.

ESAR Test

The ESAR test reads and verifies the Ethernet Station Address Register (ESAR) ROM.

To run the ESAR test, type:

```
t e
```

A display similar to the one shown in Figure 2-8 appears.

```
-05d-00 esar tst
```

Figure 2-8. Sample ESAR Test Display

Error code descriptions and probable FRUs are listed in Appendix D. Refer to Chapter 3 for instructions about replacing the FRUs. If you replace the ESAR chip, inform the customer's system manager so that the network database is updated correctly.

FPU Test

The FPU (floating point unit) test uses the add, subtract, multiply, divide, compare and convert instructions.

To run the FPU test, type:

t F

A display similar to the one shown in Figure 2-9 appears.

```
-017-00 fpu tst
```

Figure 2-9. Sample FPU Test Display

Error code descriptions and probable FRUs are listed in Appendix D. Refer to Chapter 3 for instructions about replacing the FRUs.

Video Test Patterns Test

The Video Test Patterns Test displays a variety of data patterns on the monitor.

To run the Video Test Patterns tests, type:

t f arg

The tests arguments and displays are as follows (press any key to exit each test):

Argument	Test	Display
b	Blue (for color systems only)	A blue screen
c	Color bars (for color systems only)	A screen with different color bars
e	E's	A screen of uppercase E's
g	Green (for color systems only)	A green screen
r	Red (for color systems only)	A red screen
w	White	A white screen
x	Grid	A white grid

Note: You cannot specify the repeat (r) argument for this test.

Error code descriptions and probable FRUs are listed in Appendix D. Refer to Chapter 3 for instructions about replacing the FRUs.

Keyboard Test

The Keyboard test checks the keyboard connector and instructs the keyboard to run a self-test and report the status.

To run the Keyboard test, type:

```
t k
```

Note: You cannot specify the repeat (*r*) argument for this test.

A display similar to the one shown in Figure 2-10 appears.

```
-05b-00 kybd tst
```

Figure 2-10. Sample Keyboard Test Display

Error code descriptions and probable FRUs are listed in Appendix D. Refer to Chapter 3 for instructions about replacing the FRUs.

Refer to the *DECstation 2100/3100 Operator's Guide* for more information about keyboards.

LANCE Test

The LANCE (network interface) test:

- Checks the network interface control status register using data patterns
- Runs an internal loopback test
- Runs an external loopback test in non-promiscuous mode
- Runs an internal loopback with a Cyclic Redundancy Check (CRC)
- Runs an internal loopback test in promiscuous mode

- Runs an internal loopback test with a collision check
- Runs an internal loopback test with a multicast check

To run the LANCE test, type:

t L

A display similar to the one shown in Figure 2-11 appears.

```
-04f-00 lance CSR tst
-050-00 lance Intrnl LB tst
-051-00 lance Extrnl LB tst
-052-00 lance CRC err detect tst
-053-00 lance Promiscuous mode rx tst
-054-00 lance Coll detect tst
-055-00 lance Multicast rx tst
-056-00 lance IRQ tst
```

Figure 2-11. Sample LANCE Test Display

Where,

```
LB      = loopback
rx      = receive
Coll    = collision
IRQ     = interrupt
```

Error code descriptions and probable FRUs are listed in Appendix D. Refer to Chapter 3 for instructions about replacing the FRUs.

LEDs Test

The LEDs test checks the operation of the LED display by performing a sequence of lighting one LED at a time and then unlighting one LED at a time.

To run the LEDs test, type:

t l

Note: *The correct argument is a lowercase l, not the number one.*

A display similar to the one shown in Figure 2-12 appears.

```
-058-00 leds tst
```

Figure 2-12. Sample LEDs Test Display

While the test runs, you can see the different LED configurations displayed on the status LED display.

Error code descriptions and probable FRUs are listed in Appendix D. Refer to Chapter 3 for instructions about replacing the FRUs.

Main RAM Test

The Main RAM Test tests the system's memory. This test:

- Writes and reads data patterns to memory addresses
- Performs parity bit tests that check for bad parity

To run the Main RAM test, type:

```
t m
```

A display similar to the one shown in Figure 2-13 appears.

```
-039-00  tst 16Mb mem
-035-00  wrt mram w/ 00000000
-035-00  chk mram w/ 00000000 ->  ffffffff
-035-00  chk mram w/ ffffffff
-036-00  wrt mram w/ 55555555
-036-00  chk mram w/ 55555555 ->  aaaaaaaaa
-036-00  chk mram w/ aaaaaaaaa
-037-00  wrt mram addr pat
-037-00  chk mram w/ pat
-037-00  wrt mram addr pat
-037-00  chk mram w/ pat
-038-00  mram parity bit tst
```

Figure 2-13. Sample Main RAM Test Display

Error code descriptions and probable FRUs are listed in Appendix D. Refer to Chapter 3 for instructions about replacing the FRUs.

Net RAM Test

The Net RAM test writes and reads data patterns into the network buffer.

To run the Net RAM test, type:

```
t n
```

A display similar to the one shown in Figure 2-14 appears.

```
-022-00 wrt nram w/ 0000
-022-00 chk nram w/ 0000
-023-00 wrt nram w/ 5555
-023-00 chk nram w/ 5555
-024-00 chk nram w/ aaaa
-024-00 wrt nram w/ aaaa
-025-00 wrt nram w/ ffff
-025-00 wrt nram w/ ffff
-026-00 wrt nram w/ inc pat
-026-00 chk nram w/ pat
```

Figure 2-14. Sample Net RAM Test Display

Error code descriptions and probable FRUs are listed in Appendix D. Refer to Chapter 3 for instructions about replacing the FRUs.

Mouse Test

The Mouse test checks the mouse connector and instructs the mouse to perform and report the results of its self-test.

To run the Mouse test, type:

```
t P
```

Note: You cannot specify the repeat (*r*) argument for this test.

A display similar to the one shown in Figure 2-15 appears.

```
-05a-00 mse t.st
```

Figure 2-15. Sample Mouse Test Display

Error code descriptions and probable FRUs are listed in Appendix D. Refer to Chapter 3 for instructions about replacing the FRUs.

PCC Test

The PCC (cursor chip) test:

- Runs a forced mode test of PARD1, PARD2, CURSOR A, CURSOR B
- Runs an enabled mode test of PARD1, PARD2, CURSOR A, CURSOR B

To run the PCC test, type:

t p

A display similar to the one shown in Figure 2-16 appears.

```
-03c-00  chk pcc forc mod
-03d-00  chk pcc forc mod
-03e-00  chk pcc forc mod
-03f-00  chk pcc forc mod
-03f-00  chk pcc enb mod
-041-00  chk pcc enb mod
-042-00  chk pcc enb mod
-043-00  chk pcc enb mod
```

Figure 2-16. Sample PCC Test Display

Where,

```
forc  = force
mod   = mode
enb   = enable
```

Error code descriptions and probable FRUs are listed in Appendix D. Refer to Chapter 3 for instructions about replacing the FRUs.

CSR Test

The CSR (control status register) test does the following depending on the mode you use:

Mode	Test
User	Writes and reads the Read/Write bits, generates MEMERR, and checks bits
Manufacturer/Debug	Writes and reads the Read/Write bits, generates MEMERR, checks bits, and toggles LEDs.

To run the CSR test, type:

t R

A display similar to the one shown in Figure 2-17 appears.

```
-057-00 csr tst
```

Figure 2-17. Sample CSR Test Display

Error code descriptions and probable FRUs are listed in Appendix D. Refer to Chapter 3 for instructions about replacing the FRUs.

RTC Test

The RTC (real-time clock/battery backed up RAM) test does the following depending on the mode you use:

Mode	Test
User	Saves nonvolatile RAM, writes and reads nonvolatile RAM with data patterns, writes and reads RTC registers with data patterns, restores nonvolatile RAM
Manufacturer/Debug	Saves nonvolatile RAM, writes and reads nonvolatile RAM with data patterns, restores nonvolatile RAM, writes and reads RTC registers with data patterns, sets all data and time fields, waits, then checks for update, and sets and checks periodic update.

To run the RTC test, type:

```
t r
```

A display similar to the one shown in Figure 2-18 appears.

```
-010-00 wrt nv ram w/ 00000055  
-010-00 chk nv ram w/ 00000055  
-011-00 wrt nv ram w/ 000000aa  
-011-00 chk nv ram w/ 000000aa  
-012-00 wrt nv ram w/ inc pat  
-012-00 chk nv ram w/ pat
```

Figure 2-18. Sample RTC Test Display

Where,

```
wrt = write  
chk = check  
nv = nonvolatile  
inc = incrementing  
pat = pattern
```

Error code descriptions and probable FRUs are listed in Appendix D. Refer to Chapter 3 for instructions about replacing the FRUs.

SII Test

The SII test checks the SCSI interface to the SCSI bus. It:

- Writes and reads data patterns to the SCSI buffer
- Performs target tests
- Performs initiator tests
- Attempts to place recognized SCSI devices on-line. Devices that cannot be placed on line have an off-line self-test executed. All extended tests executed under the SCSI menu require devices to be on-line. To run SCSI diagnostics, see Preparing for SCSI Extended Self-Tests in this chapter.

To run the SII test, type:

```
t s
```

A display similar to the one shown in Figure 2-19 appears.

```
-047-01  SII bfr adr test
-048-01  sii tgt ilpbk
-048-02  tgtst:  STLP <- 4
-048-03  tgtst:  bldg obnd cmd/dta
-048-04  tgtst:  set lpbk md
-048-05  tgtst:  sel + pen
-048-06  tgtst:  id <- 7
-048-07  tgtst:  en dssi md
-048-08  tgtst:  dev 0 sel dev 7
-048-09  tgtst:  dsel
-048-0a  tgtst:  snd cmd[0]
-048-0a  tgtst:  snd cmd[1]
-048-0a  tgtst:  snd cmd[2]
-048-0a  tgtst:  snd cmd[3]
-048-0a  tgtst:  snd cmd[4]
-048-0a  tgtst:  snd cmd[5]
-048-0a  tgtst:  snd cmd[6]
-048-0b  tgtst:  snd dta[0]
-048-0b  tgtst:  snd dta[1]
-048-0b  tgtst:  snd dta[2]
-048-0b  tgtst:  snd dta[3]
-048-0b  tgtst:  snd dta[4]
-048-0b  tgtst:  snd dta[5]
-048-0b  tgtst:  snd dta[6]
-048-0b  tgtst:  snd dta[7]
-048-0b  tgtst:  snd dta[8]
-048-0b  tgtst:  snd dta[9]
-048-0b  tgtst:  snd dta[10]
-048-0c  tgtst:  rcv sts
-048-0d  tgtst:  chk bfr sts
-048-0e  tgtst:  chk cmd blk
-048-0f  tgtst:  chk dta bytes
-048-10  TGSTS:  OK
```

(continued on next page)

Figure 2-19. Sample SII Test Display

```
-049-01  sii ini  ilpbk tst
-049-02  initst:  bld obnd pkt ad = bb000020
-049-03  initst:  ILP <- 4
-049-04  initst:  set lpbk md
-049-05  initst:  sel + pen
-049-06  initst:  ID <- 7
-049-07  initst:  arb wina
-049-08  initst:  dssi md
-049-09  initst:  BSYa + CDa
-049-0a  initst:  rcv cmd[0]
-049-0a  initst:  rcv cmd[1]
-049-0a  initst:  rcv cmd[2]
-049-0a  initst:  rcv cmd[3]
-049-0a  initst:  rcv cmd[4]
-049-0a  initst:  rcv cmd[5]
-049-0a  initst:  rcv cmd[6]
-049-0b  initst:  -> dta phse
-049-0c  initst:  rcv dta[0]
-049-0c  initst:  rcv dta[1]
-049-0c  initst:  rcv dta[2]
-049-0c  initst:  rcv dta[3]
-049-0c  initst:  rcv dta[4]
-049-0c  initst:  rcv dta[5]
-049-0c  initst:  rcv dta[6]
-049-0c  initst:  rcv dta[7]
-049-0c  initst:  rcv dta[8]
-049-0c  initst:  rcv dta[9]
-049-0c  initst:  rcv dta[10]
-049-12  initst:  -> sts phse
-049-0d  initst:  dscon
-049-0e  initst:  chk bfr sts
-049-0f  initst:  chk CSTAT
-049-10  initst:  intrd
-049-11  INITST:  OK
```

(continued on next page)

Figure 2-19. Sample SII Test Display

```

-04c-01  SCSI scndev
-04b-01  STRT SCSI DEV TSTG
-04b-02  ofl tst u# 2
-04b-04  ofln slftst ok u# 2
-04b-02  ofl tst u# 1
-04b-04  ofln slftst ok u# 1
-04b-02  ofl tst u# 0
-04b-04  ofln slftst ok u# 0

```

Figure 2-19. Sample SII Test Display

Where,

```

adr      = address
arb      = arbitration
bfr      = buffer
bldg     = building
BSY      = busy
dscon    = disconnect
dsel     = deassert select
dta      = data
en       = enable
ilpbk    = internal loopback
ini      = initiator
intrd    = interrupt disable
md       = mode
obnd     = outbound
pen      = parity enable
phse     = phase
pkt      = packet
scndev   = scanning for devices
sts      = status
tgt      = target
wina     = force win

```

Error code descriptions and probable FRUs are listed in Appendix D. Refer to Chapter 3 for instructions about replacing the FRUs.

TLB Test

The TLB test writes data to and reads data from the Translate Lookaside Buffer (TLB) using data patterns. The test also checks responses to probes on address match.

To run the TLB test, type:

```
t t
```

A display similar to the one shown in Figure 2-20 appears.

```
-05e-00 tlb tst
```

Figure 2-20. Sample TLB Test Display

Error code descriptions and probable FRUs are listed in Appendix D. Refer to Chapter 3 for instructions about replacing the FRUs.

VDAC Test

The VDAC (Video Digital to Analog Converter) test:

1. Uses CSR bits to compare Red, Green, and Blue outputs (for color systems only)
2. Writes and reads the color map using data patterns
3. Writes and reads the overlay registers using data patterns

To run the VDAC test, type:

```
t V
```

A display similar to the one shown in Figure 2-21 appears.

```
-009-00 wrt vdac map w/ inc pat  
-009-00 chk vdac map w/ pat  
-00a-00 wrt vdac ovrly w/ inc pat  
-00a-00 chk vdac ovrly w/ pat
```

Figure 2-21. Sample VDAC Test Display

The workstation must have a Video SIM module for this test. If the workstation is a server, you see an error message when you run this test.

Error code descriptions and probable FRUs are listed in Appendix D. Refer to Chapter 3 for instructions about replacing the FRUs.

Video RAM Test

The Video RAM test writes and reads data patterns into the video buffer.

To run the Video RAM test, type:

```
t v
```

The workstation displays a white screen with bars, clears the screen, and returns to the console prompt.

The workstation must have a Video SIM module for this test. If the workstation is a server, you see an error message when you run this test.

Error code descriptions and probable FRUs are listed in Appendix D. Refer to Chapter 3 for instructions about replacing the FRUs.

Write Buf Test

The Write Buf test checks the R2000 interface to main memory. It writes to illegal addresses and checks for a write error address.

To run the Write Buf test, type:

```
t w
```

A display similar to the one shown in Figure 2-22 appears.

```
-059-00 wb err addr tst
```

Figure 2-22. Sample Write Buf Test Display

Error code descriptions and probable FRUs are listed in Appendix D. Refer to Chapter 3 for instructions about replacing the FRUs.

Preparing for SCSI Extended Self-Tests

Before running the SCSI extended self-tests:

1. View the SCSI Storage Device Listing, if desired.
2. Select the appropriate test modes (refer to Selecting Test Modes)
3. Terminate connectors, or install loopback connectors, if necessary (refer to Table 2-4).

Viewing the SCSI Storage Device Listing

To obtain information about the recognized storage devices connected to the SCSI bus, type the following at the console prompt:

```
scsi pb
```

The workstation displays a list of all the recognized SCSI devices and vendor information such as version number, and response data format. Figure 2-23 shows a typical listing of SCSI storage devices.

```
U[7]
U[6]KN01--SII
U[5]
U[4]
U[3] Dev typ 0 RZ
          RMB          0x0
          Vrs          1
          Format        1 CCS
          Add len      31
          Vndr         DEC
          PID          RZ23      (C) DEC
          Frevlvl      0618
U[2]
U[1]
U[0]
>>
```

Figure 2-23. SCSI Device List

The Unit number is the SCSI ID address associated with a specific device. The Device type refers to the type of device that has a specific SCSI ID address.

Running SCSI Extended Self-Tests

All SCSI tests first check which devices are on the SCSI bus. If the devices are not ready, the test attempts to put the devices on line. An error message appears if the test cannot put a device on line.

Note: Status and error messages are listed and described in Appendix D. Probable FRUs are included in the error-code lists.

These tests consist of canned device tests for RZ, RX, TZ, and CDROM (RRD) class devices. The canned disk test writes 8Kbyte blocks filled with block address data to 100 or 200 random locations on the disk surface. It verifies the result by read-back and buffer-compare.

The canned tape test writes alternate db6c and its complement to the tape in the form of 512-byte tape blocks. The test writes one block of data to the tape with parity checking enabled. A read-back with parity and full data-buffer-compare is then performed.

The CDROM disc tests require a test diskette for extended mode and perform “controller only” hardware tests in user mode. Two levels of SEND DIAGNOSTIC are invoked.

In user mode, all devices receive send diagnostic with a self-test bit set in byte 2 of the command block. This test performs off-line nondestructive testing of the device, usually involving no writes to the media and testing only the controller hardware. Invoking extended test sets self-test and unofl bits in byte 2 of the send diagnostic command block. The extended test invokes a detailed self-test of the device involving writes to diagnostic cylinders of the disk or to installed scratch media.

For a read-only device, device-read capability is checked. Features such as ECC, parity firmware checksum, data-buffer integrity, etc. are exercised in this read-only mode.

For all error messages, follow the advice of the error message.

*Note: If you use CTRL/C to abort a test, be sure to use the **init** and **scsi rs** commands to reset the system before proceeding.*

Canned Disk Test

Caution: *This test will destroy customer data on media.*

To run this test, type:

```
scsi cd <unit>
```

You are prompted to confirm that you want to overwrite the disk.

To stop the test, type any character at the confirmation prompt.
To continue, type (uppercase):

```
Y
```

A display similar to the one shown in Figure 2-24 appears each time the workstation completes a write and read pass.

```
  Ps      Bk      Ercnt
  ---      -      -
  100     37779     0
```

Figure 2-24. Sample Canned Disk Test Display

Where,

```
Ps      = pass number
Bk      = block
Ercnt   = error count
```

Error code descriptions and probable FRUs are listed in Appendix D.

Refer to the Removing the Drive Mounting Panel section in Chapter 3, *The RZ22/23 Disk Drive Service Manual*, or *The RZ55 Disk Drive Service Manual* for instructions.

To replace the system module, refer to the Replacing the System Module section in Chapter 3 for instructions.

For all error messages, follow the advice of the error message.

Canned Floppy Disk Test

Use a scratch diskette (HD only) for this test.

Caution: *This test will destroy customer data on media.*

To run this test, type:

scsi cf <unit>

You are prompted to confirm that you want to overwrite the disk.

To stop the test, type any character at the confirmation prompt.
To continue, type (uppercase):

Y

A display similar to the one shown in Figure 2-25 appears each time the workstation completes a write and read pass.

Ps	Blk	ErCnt
100	37779	0

Figure 2-25. Sample Canned Floppy Disk Test Display

Where,

Ps = pass number
Blk = block
ErCnt = error count

Error code descriptions and probable FRUs are listed in Appendix D. Refer to the Disk Drive Replacement: Floppy Mounting Panel section in Chapter 3, *The RX23 Floppy Disk Drive Service Manual*. for instructions.

To replace the system module, refer to the Replacing the System Module section in Chapter 3 for instructions.

Canned Tape Test

Use a blank TK50Z tape cartridge or a write enabled scratch tape.

Caution: *This test will destroy data on media.*

To run this test, type:

scsi ct <unit>

You are prompted to confirm that you want to overwrite the tape.

To stop the test, type any character at the confirmation prompt.
To continue, type (uppercase):

Y

A display similar to the one shown in Figure 2-26 appears:.

```
-04b-09 rz/tz wrt?  
Y/N?  
-04b-10 rwdg -> ld pt  
-04b-12  
wrt blk 0  
-04b-13 wrt cpl 1 blks  
-04b-10 rwdg -> ld pt  
-04b-1a rd blk 0  
-04b-1b Tz1 OK
```

Figure 2-26. Sample Canned Tape Test Display

Error code descriptions and probable FRUs are listed in Appendix D. Refer to the *TK50Z Technical Manual* for instructions.

To replace the system module, refer to the Replacing the System Module section in Chapter 3 for instructions.

Canned CDROM Disc Test

Note: To run this test you need to insert the RRD40 test disc (PN 30-23507-03) shipped with the RRD40.

To run this test, type:

```
scsi er <unit>
```

A display similar to the one in Figure 2-27 appears.

```
-04b-09 rz/tz wrt?  
Y/N?  
-04b-1c rrd3 mkrdy  
-04b-1d Ext_sltst RRD3  
-04b-1e RRD3 OK
```

Figure 2-27. Sample Canned CDROM Test Display

Error code descriptions and probable FRUs are listed in Appendix D.

Refer to the *RRD40 Owner's Manual* for instructions.

To replace the system module, refer to Replacing the System Module in Chapter 3 for instructions.

Extended Self-Test

The Extended Self-Test performs a full data check and confirm on Digital peripherals only. Use a blank TK50Z tape cartridge or a write enabled scratch tape to test the TK50Z.

Caution: This test will potentially destroy data on media.

To run this test, type:

```
scsi ex <unit>
```

You are prompted to confirm that you want to overwrite the media.

To stop the test, type any character at the confirmation prompt. To continue, type (uppercase):

```
Y
```

A display similar to the one shown in Figure 2-28 appears.

```
-04b-1f Ext slftst u5  
-04b-20 U5 OK
```

Figure 2-28. Extended Mode Self-Test Display

Error code descriptions and probable FRUs are listed in Appendix D.

Refer to the device Owner's Manual for instructions.

To replace the system module, refer to Replacing the System Module in Chapter 3 for instructions.

t1—SII Buffer Test

This test module consists of two tests: SII Buffer Address test, and SII Buffer Memory test.

Note: You do not need a SCSI loopback connector or a SCSI terminator when running this test.

The address test is a fast test that identifies potential addressing problems with the SII buffer. The buffer is 64Kbytes of 16-bit words addressed by a 16-bit address field. A "1" is walked across this field while addressing locations 1, 2, 4, 8, etc. The test also writes these locations with their address data. For example, address 8 receives data 8. At the end of the pass, each location is checked to assure that it contains its address.

In the buffer test, four patterns are written one-per-pass to each of the 64Kbyte word locations. At the end of each pass, the patterns are read back and compared. The 16-bit patterns are 0x0000, 0xffff, 0xaaaa, and 0x5555.

To run this test, type:

```
scsi t1
```

A display similar to the one shown in Figure 2-29 appears.

```

-047-01  SII bfr adr tst
-047-04  siiatst: 4ptn wrt
-047-02  siiatst: SII bfr tst
-047-03  siiiatst: chk sii buf          0 ?
-047-02  siiatst: SII bfr tst
-047-03  siiiatst: chk sii buf          aaaa ?
-047-02  siiatst: SII bfr tst
-047-03  siiiatst: chk sii buf          5555 ?
-047-02  siiatst: SII bfr tst
-047-03  siiiatst: chk sii buf          ffff ?

```

Figure 2-29. Sample t1 Test Display

Error code descriptions and probable FRUs are listed in Appendix D. To replace the system module, refer to Replacing the System Module in Chapter 3 for instructions.

t2—SII Target Mode Test

The Target Mode test utilizes internal test features of the SII to verify its ability to operate and respond in the target mode of operation. The R2000 CPU chip emulates the initiator, providing the stimulus to the SII through writes of the SC1 and SDb registers of this device. The R2000 monitors chip response by examining SC1, which is updated by the SII as it transitions through SCSI bus phases.

Failures in this test mode are almost exclusively SII chip failures. Refer to the ANSI SCSI specification, SII chip specification, and PMAX functional specification for a more detailed description of SCSI and the SII.

Note that a superset of the SCSI protocol called DSSI is used in this test. It is in every respect similar in operation to SCSI. A command and data packet is built in memory and transmitted to the SII. The SII stores these packets in SII buffer memory space for later examination by the R2000.

Note: It is recommended that you use a SCSI terminator. You do not need a SCSI loopback connector when running this test.

To run this test, type:

```
scsi t2
```

A display similar to the one shown in Figure 2-30 appears.

```
-048-01  sii tgt ilpbk
-048-02  tgtst:  STLP <- 4
-048-03  tgtst:  bldg obnd cmd/dta
-048-04  tgtst:  set lpbk md
-048-05  tgtst:  sel + pen
-048-06  tgtst:  id <- 7
-048-07  tgtst:  en dssi md
-048-08  tgtst:  dev 0 sel dev 7
-048-09  tgtst:  dsel
-048-0a  tgtst:  snd cmd[0]
-048-0a  tgtst:  snd cmd[1]
-048-0a  tgtst:  snd cmd[2]
-048-0a  tgtst:  snd cmd[3]
-048-0a  tgtst:  snd cmd[4]
-048-0a  tgtst:  snd cmd[5]
-048-0a  tgtst:  snd cmd[6]
-048-0b  tgtst:  snd dta[0]
-048-0b  tgtst:  snd dta[1]
-048-0b  tgtst:  snd dta[2]
-048-0b  tgtst:  snd dta[3]
-048-0b  tgtst:  snd dta[4]
-048-0b  tgtst:  snd dta[5]
-048-0b  tgtst:  snd dta[6]
-048-0b  tgtst:  snd dta[7]
-048-0b  tgtst:  snd dta[8]
-048-0b  tgtst:  snd dta[9]
-048-0b  tgtst:  snd dta[10]
-048-0c  tgtst:  rcv sts
-048-0d  tgtst:  chk bfr sts
-048-0e  tgtst:  chk cmd blk
-048-0f  tgtst:  chk dta bytes
-048-10  TGST:  OK
```

Figure 2-30. Sample t2 Test Display

Error code descriptions and probable FRUs are listed in Appendix D. To replace the system module, refer to Replacing the System Module in Chapter 3 for instructions.

t3—SII Initiator Mode Test

This test uses the internal loopback test mode of the SII to verify that the SII is capable of performing the initiator role. The R2000 chip emulates the target function and provides stimulus by writing to the SC1 and SDB registers of the SII. The CPU monitors SC1 and SDB to determine SII response to target stimulus. Refer to the ANSI SCSI specification, SII

chip specification, and PMA^X functional specification for more details about the SCSI and the SII chip.

Failure of this test points almost exclusively to an SII chip or system module problem. Also check that cabling is properly installed and seated.

A data and command packet, containing pointers and other DSSI specific information, is built in memory and received by the SII buffer memory area. The contents of this buffer are examined after the command and data transfer to verify correct reception of the command and data packets.

Note: *It is recommended that you use a SCSI terminator. You do not need a SCSI loopback connector when running this test.*

To run this test, type:

scsi t3

A display similar to the one shown in Figure 2-31 appears.

```
-049-01  sii ini ilpbk tst
-049-02  initst:  bld obnd pkt ad = bb000020
-049-03  initst:  ILP <- 4
-049-04  initst:  set lpbk md
-049-05  initst:  sel + pen
-049-06  initst:  ID <- 7
-049-07  initst:  arb wina
-049-08  initst:  dssi md
-049-09  initst:  BSYa + CDa
-049-0a  initst:  rcv cmd[0]
-049-0a  initst:  rcv cmd[1]
-049-0a  initst:  rcv cmd[2]
-049-0a  initst:  rcv cmd[3]
-049-0a  initst:  rcv cmd[4]
-049-0a  initst:  rcv cmd[5]
-049-0a  initst:  rcv cmd[6]
-049-0b  initst:  -> dta phse
-049-0c  initst:  rcv dta[0]
-049-0c  initst:  rcv dta[1]
-049-0c  initst:  rcv dta[2]
-049-0c  initst:  rcv dta[3]
-049-0c  initst:  rcv dta[4]
-049-0c  initst:  rcv dta[5]
-049-0c  initst:  rcv dta[6]
-049-0c  initst:  rcv dta[7]
-049-0c  initst:  rcv dta[8]
-049-0c  initst:  rcv dta[9]
-049-0c  initst:  rcv dta[10]
-049-12  initst:  -> sts phse
```

Figure 2-31. Sample t3 Test Display

```
-049-0d  initst:  dscon
-049-0e  initst:  chk bfr sts
-049-0f  initst:  chk CSTAT
-049-10  initst:  intrd
-049-11  INITST:  OK
```

Figure 2-31. Sample t3 Test Display

Error code descriptions and probable FRUs are listed in Appendix D. To replace the system module, refer to Replacing the System Module in Chapter 3 for instructions.

t4—SCSI Loopback and External Drive Tests

These tests, with the aid of a loopback connector, check the functionality of the SCSI bus drivers and control signals. The loopback connector check consists of driving the SC1 register out around the loop and receiving the result in the SDB register. Numerous patterns are then driven around the loop to check the data drivers.

The external drive tests then check the functionality of the target and initiator mode control signal drivers. Nine bits are driven around the loop. In the first half of the test, data plus parity is tested. In the next half of the test, the control signals are driven onto the data bus and sensed in the SDB register.

You must install a SCSI loopback connector in the SCSI connector on the system module for this test; disconnect all SCSI devices. The procedure for installing an internal SCSI loopback connector is described in Terminating Connectors in this chapter.

***Note:** To run this test you must set the mode to Manufacturer/Debug mode. Refer to Selecting Test Modes in this chapter to change the test mode manually.*

To run this test, type:

```
scsi t4
```

A display similar to the one shown in Figure 2-32 appears.

```
-04a-02  sii exdrv lpbk tsts  
-04a-01  scsi lpbk chk  
?0bd-0f  err ext lpbk? 000001ff 00000084
```

Figure 2-32. Sample t4 Test Display

“Loopback not found” error message interpretation:

```
?0bd-0f err ext lpbk? xxxx yyyy
```

Where,

```
xxxx = expected data (0x1FF)  
yyyy = actual data
```

If the actual data = 0x000, the loopback is installed backwards or otherwise improperly installed.

If the actual data = non-zero, try another loopback (if available) and compare results.

Error code descriptions and probable FRUs are listed in Appendix D. To replace the system module, refer to Replacing the System Module in Chapter 3 for instructions.

SCSI Extended Self-Tests Troubleshooting

The following troubleshooting information includes:

- SII Errors—Code 0x0bd
- SII Timeout Errors—Code 0x0be
- SII Target and Initiator Tests
- SCSI Errors—Code 0x0bf
- SCSI Bus Troubleshooting
- SCSI Device Errors—Code 0x0d3

SII Errors—Code 0x0bd

These errors are flagged primarily during the internal testing of the SII in the target and initiator modes. They may also occur during the external loopback test or during an SII chip setup prior to performing a probe operation.

Those errors that indicate the inability of the SII register to be set to a desired value, point to a general SII subsystem failure and require replacement of the system module as a last resort. For external drive tests (extdrv), care should be taken that the loopback is properly oriented and seated in the SCSI connection on the system module.

In messages that contain numeric output, the notation aaaa and eeee represent hexadecimal quantities denoting the actual and expected values of the particular SII register referenced in that message. Refer to the SII chip specification and the PMAX functional specification for a detailed description of the SII.

SII Timeout Errors—Code 0x0be

These errors occur during internal testing of the SII in the target and initiator modes. The R2000 CPU is used to provide stimulus to the SII as it is tested for its ability to perform initiator and target roles.

All errors in this category point to the SII chip as the source of trouble. For FRU this means replace the system module as a last resort. It is recommended that the internal and external SCSI cable be disconnected and the test be rerun after issuing a hardware reset. A recurrence of these errors under this

condition points to the SII chip/system module as the source of failure.

SII Target and Initiator Tests

The SII SCSI interface chip provides a means of testing the chip for the ability to support the initiator and target roles as defined in the ANSI x131-1986 SCSI specification.

When tested as a target, the ability of the SII to drive those bus signals required for target mode operation is checked. The R2000 CPU is used as the initiator. The SC1 register of the SII is used to set and monitor the bus signal state. Refer to the SII chip specification and/or P_{MAX} functional specification if a more detailed explanation of these modes and the SII is required.

When tested as an initiator, the R2000 drives the appropriate bits to set the SC1 register which then acts as the target device.

All SII registers are 16 bit quantities and all quantities represented as xxxx are expressed in hexadecimal.

SCSI Errors—Code 0x0bf

This class of error is flagged when a SCSI protocol violation is detected. For example, a change to an unexpected phase during a bus transaction, or an unrecognized message passed from target to host. It is also used to signal a general bus failure during manufacturing mode of test. The meaning of failures in the SCSI error class is specific to the error event and possibilities are given with each error code explanation.

SCSI Bus Troubleshooting

Many of the errors reported in this class are flushed due to an improperly initialized or synchronized device, faulty bus drivers, or cabling/connector problems. In addition, during new device installs, incorrect jumpering or power sequencing problems may hang the bus.

Hot reconfiguration of the system is not supported. When installing new devices, the following power sequencing is recommended:

1. Power down the external peripherals.
2. Power down the system box.
3. Install new devices as required.
4. Power up all external peripherals.
5. Power up the system box.
6. Perform "scsi pb" to verify the configuration.

The following courses of action are recommended to clear/correct the indicated error condition.

1. Reset the hardware using the back-panel reset. Retry the operation.
2. Inspect interconnects, cabling, cable lengths, and proper end of the line termination on any external SCSI devices. If none, the supplied external SCSI terminator should be installed on the system box. Also verify that each peripheral box is receiving power.
3. Check the SCSI address space using the "scsi pb" command. Verify that each installed device is correctly identified. Devices that do not show may have the address incorrectly jumpered. Check and resolve any address problems. Retry the failing operation. If unsuccessful, go to the next step.
4. If the peripheral of interest is an external peripheral, disconnect all external peripherals. Terminate the SCSI bus with the supplied SCSI terminator. If an internal RZ is installed, run the SCSI cd test (providing no user data is present). If user data is preset, run "t s" in user mode. If successful, go to step 6. Otherwise, go to step 5.

5. Disconnect all internal RZs and execute "t s" in user or manufacturing mode. Note that "t s" requires a loopback in manufacturing mode. If you do not have the loopback, execute scsi t1, scsi t2, scsi t3 which are the equivalent of the manufacturing mode tests excluding the loopback test (scsi t4).

If successful, reconnect one internal RZ device at a time, paying attention to power, address jumpering and cable orientation as you do so. Power up and run "scsi cd" for each device as suggested in step 4. Replace defective drives/cables as appropriate. If there are external peripherals proceed to step 6.

6. Reconnect external peripherals one at a time, observing proper termination rules. Reset and run the appropriate canned test or "t s" in user mode, if user data is present. Replace cables/drives etc., as indicated.

SCSI Device Errors—Code 0x0d3

Errors of this type generally occur during a device test operation. They may specify the unready state of the device such as not loaded, spun-up or on-line, which may be corrected by rectifying the condition that caused the error status. The error may also signal a more catastrophic event such as a device hang or no response. Possible fault causes are given as appropriate with each error message.

Running Extended Self-Tests Without a Functioning Monitor

If your monitor is not working, obtain the results of the extended self-tests by observing the LED display on the back of the system unit. Use the procedures previously described in the Running Console Extended Self-Tests section in this chapter to run individual extended self-tests.

The LEDs are arranged in two groups of four and form a binary display. As the DECstation 2100/3100 performs an extended self-test, the LEDs blink accordingly. If an error is detected, the workstation halts on the LED code corresponding to the problem.

If using the status LED display instead of a monitor:

1. Terminate appropriate connectors. Refer to the Terminating Connectors section in this chapter for instructions.
2. Using the keyboard, type the appropriate command to run a particular extended-self test.

The LED display blinks as the various tests are performed. Tests that pass should not cause the LED display to remain on any code for more than 30 seconds.

Interpreting the Status LED Codes

Use Table 2-5 to determine where the error occurred and what action to take next. The binary codes in the table reflect the status LED display as viewed from the back of the system unit.

Table 2-5. LED Extended Self-Test Display Codes

Test Performed	LED Display 1 = LED on	Hexadecimal Code	Suggested Action
LANCE	0110 1011	6b	Check the network connection. Make sure the selected Ethernet connection is installed properly, terminated, or connected to a network. Replace the system module.
	0110 1100	6c	
	0110 1101	6d	
	0110 1110	6e	
	0110 1111	6f	
	0111 0000	70	
	0111 0001	71	
	0111 0010	72	
	0111 0011	73	
	0111 0100	74	
	0111 0101	75	
	0111 0110	76	
Cache	0110 1001	79	Replace the system module.
	0111 1010	7a	
	0111 1011	7b	
	0111 1100	7c	
	0111 1101	7d	
	0111 1110	7e	
	0111 1111	7f	
	1000 0000	80	
	1000 0001	81	
	1000 0010	82	
	1000 0011	83	
	1000 0100	84	
STACK_ ERROR	1000 0111	87	Replace the D SIM modules, number 1 or 2 (error is in first 64 Kbytes of memory) or the system module.
	1000 1000	88	
	1000 1001	89	
Video RAM	1000 1010	8a	Replace the Video SIM module or the system module.

(continued on next page)

Table 2-5 (Cont.). LED Extended Self-Test Display Codes

Test Performed	LED Display 1 = LED on	Hexadecimal Code	Suggested Action
Disk RAM	1000 1011	8b	Replace the system module.
Net RAM	1000 1100	8c	Replace the system module.
NVRAM	1000 1101	8d	Replace the system module.
VDAC	1001 0000 1001 0001 1001 0010	90 91 92	Check the video cable, replace the Video SIM module, or the system module.
RTC	1001 0100 1001 0101 1001 0110 1001 0111 1001 1000	94 95 96 97 98	Replace the system module.
FPU	1001 1011	9b	Replace the system module.
PCC	1010 0100 1010 0101	a4 a5	Replace the system module.
DZ	1010 1010 1010 1011 1010 1100 1010 1101 1010 1110 1010 1111 1011 0000 1011 0001	aa ab ac ad ae af b0 b1	Check all connections. Replace the system module.

(continued on next page)

Table 2-5 (Cont.). LED Extended Self-Test Display Codes

Test Performed	LED Display 1 = LED on	Hexadecimal Code	Suggested Action
ESAR	1011 0110	b6	Check that the ESAR chip is seated properly or replace the system module.
Write Buf	1011 0111	b7	Replace the system module.
CSR	1011 1000	b8	Replace the system module.
SII	1011 1101 1011 1110 1011 1111 1101 0011	bd be bf d3	Replace the system module. Check the SCSI cable, SCSI device, terminators and loopback connectors.
TLB	1100 1000	c8	Replace the system module.
Color Mask	1100 1001	c9	Replace the Video SIM module or the system module.
Keyboard	1101 0000	d0	Replace the keyboard or the system module.
Mouse	1101 0001	d1	Replace the mouse or the system module.
Main RAM	1101 0010 1101 0100	d2 d4	Replace the D SIM modules or the system module.

Base System FRU Replacement

This chapter explains how to replace the DECstation 2100/3100 base system FRUs.

————— ESD SENSITIVE DEVICES —————

Note: Follow ESD protection procedures. Wrist straps, table mats, and ESD procedures are required.

Two disk drive mounting panel configurations are available:

1. Non-floppy drive mounting panel
2. Floppy drive mounting panel

Refer to the appropriate drive mounting panel section for instructions on removal, installation, and add-on of RX23 and RZ23/RZ23L/RZ24 disk drives.

Use the information in Table 3-3 to set the unit select jumpers for each drive.

To install the RX23 floppy drive upgrade, refer to the instructions that are included in the upgrade kit.

Note: Your system must have ULTRIX 3.1 or UWS 2.1 (Rev. 14) or higher to support an RX23 floppy disk drive. Do not install an RX23 drive in a system with a lower version of ULTRIX.

If you are upgrading memory, refer to Installing Add-On D SIM Modules in this chapter for instructions.

All of these instructions assume that you are facing the front of the system unit.

Note: After replacing an FRU, verify that you have solved the problem by rerunning the power-up self-test or the appropriate extended self-test.

For monitor repair, refer to the appropriate service guide for the monitor (see Table 3-1).

Table 3-1. DECstation 2100/3100 Monitor Reference

Monitor	Document Title	Order Number
VR150 (monochrome, 15")	<i>VR150 Pocket Service Guide</i>	EK-VR150-PS
VR160 (color, 15")	<i>VR160 Pocket Service Guide</i>	EK-VR160-PS
VR262 (monochrome, 19")	<i>VR262 Pocket Service Guide</i>	EK-VR262-PS
VR297 (color, 16")	<i>VR297 Pocket Service Guide</i>	EK-VR297-PS
VR299 (color, 19")	<i>VR299 Pocket Service Guide</i>	EK-VR299-PS

For external device repair, refer to the appropriate service guide (see Table 3-2).

Table 3-2. External Device Reference

Device	Document Title	Order Number
RZ55 disk drive	<i>The RZ55 Disk Drive Service Manual</i>	EK-RZ55D-SV
RZ22/23/23L/24 disk drive	<i>The RZ22/23/23L/24 Disk Drive Service Manual</i>	EK-RZ223-SV
RX23 floppy disk drive	<i>The RX23 Diskette Drive Subsystem Service Manual</i>	EK-RX23D-SV
TK50Z tape drive	<i>TK50Z Technical Manual</i>	EK-0TK50-TM
RRD40 compact disc drive	<i>The RRD40 Owner's Guide</i>	EK-RRD40-OM

Base System FRUs

The FRUs in the DECstation 2100/3100 base system are:

- Battery pack
- RZ23/RZ23L/RZ24 disk drive (internal drive) HDA with electronics or electronics module
- RX23 floppy disk drive module
- Power-supply assembly
- SCSI cable
- SCSI power cable
- System module (with ESAR chip)
- D SIM module
- Video SIM (C SIM or M SIM) module

Refer to Appendix B for a list of part numbers.

Warning: *Before starting any FRU replacement procedures, shut down the operating system software, turn the workstation off, disconnect power cords, and disconnect the external SCSI cable.*

Removing the System Unit Cover

Do the following:

1. Loosen, but do not remove, the two screws at the back of the unit.
2. Facing the front of the system unit, grip both sides of the cover and slide it toward you to disengage it from the guides.
3. Lift the cover away from the unit and set it aside (see Figure 3-1).

To replace the cover, do the following:

Reverse the procedure by first sliding the cover towards the back panel to re-engage the guides.

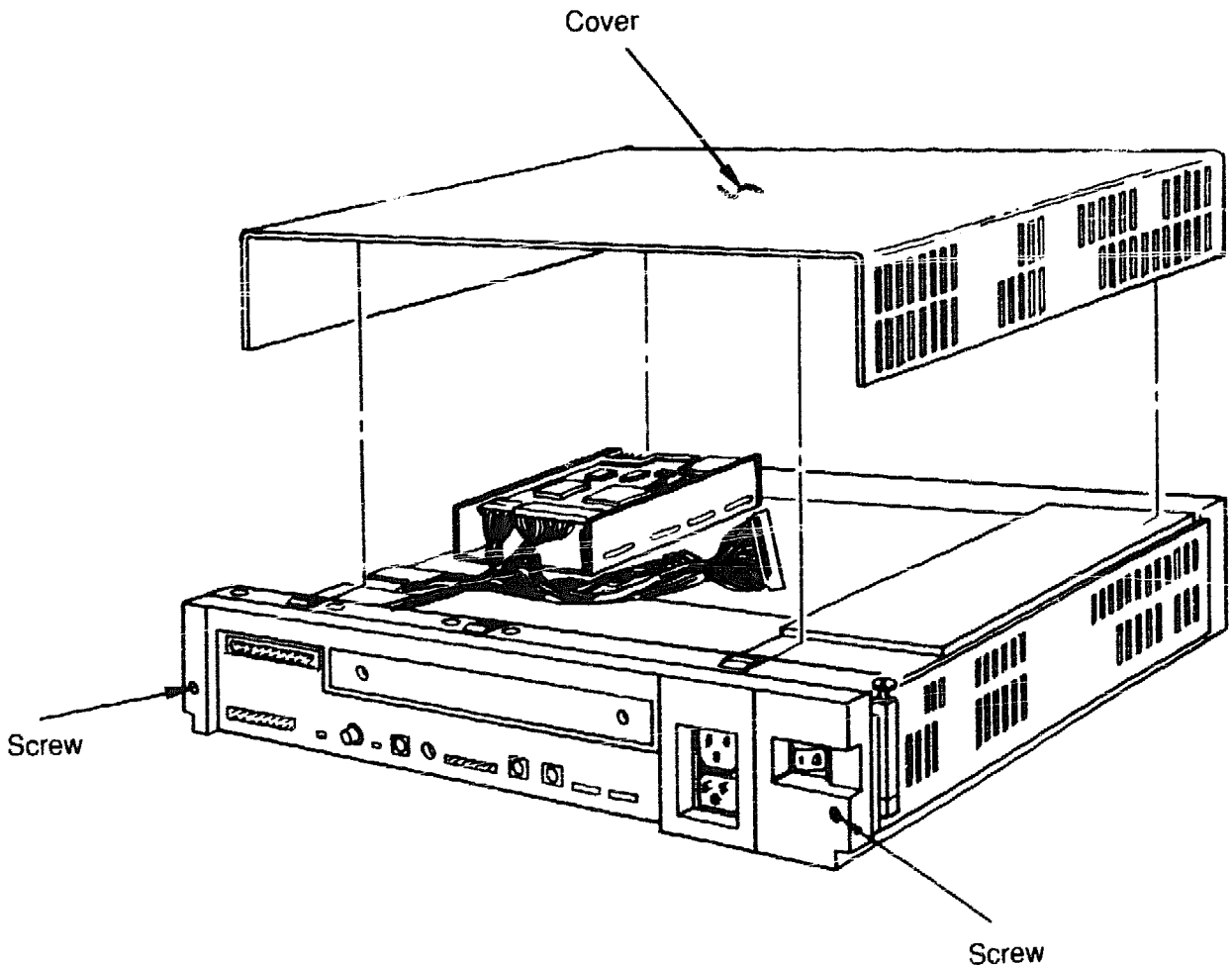

Figure 3-1. Removing the System Unit Cover

Removing the Drive Mounting Panel

Remove the drive mounting panel to replace a D SIM module, a Video SIM module, or the system module. These removal/installation instructions apply to both drive mounting panel configurations (floppy and non-floppy versions). Refer to Figure 3-2 and do the following:

1. Remove the cover as described in Removing the System Unit Cover.
2. Disconnect the drive power cable from the power supply connector by pulling the two connectors in opposite directions.
3. Disconnect the SCSI cable connector from the system module by pushing the connector latches in opposite directions. This disengages the connector. Lift the connector up and away from the system module.
4. Unscrew the two captive screws, located on the front side of the drive mounting panel, the two captive screws on the back side, and the one captive screw on the power supply assembly.
5. Loosen the three drive mounting panel Phillips-head screws on the side opposite the power supply assembly.
6. Take the drive mounting panel out of the unit by grasping it with both hands and sliding it towards the front of the system unit, releasing it from the chassis. Then, lift off the drive mounting panel and place it aside. Be careful not to damage the metal gasket at the back right-hand side of the mounting panel and carefully avoid the drive power cable protruding from the power supply.

To replace the drive mounting panel, reverse the steps in this procedure.

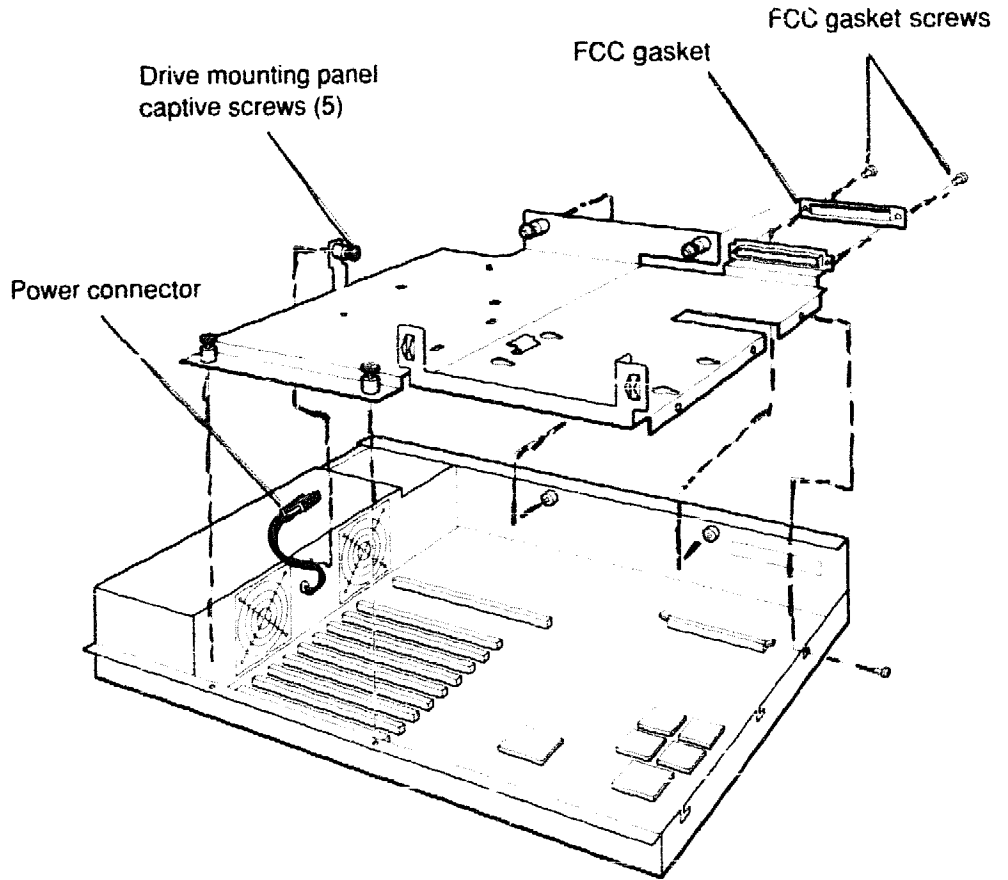

WSE1M002

Figure 3-2. Removing the Drive Mounting Panel

Disk Drive Replacement: Non-Floppy Mounting Panel

This section describes how to replace or add-on an RZ23/RZ23L/RZ24 disk drive to a non-floppy mounting panel.

The replacement and add-on disk drive installation package contains the following items for each RZ23/RZ23L/RZ24 disk drive:

- Preassembled for floppy drive mounting panel:
 - Disk drive module
 - Disk drive bracket (with tabs and captive screw)
 - Four 6/32 screws (attaching the bracket to the drive)
 - Jumper blocks (attached) (to select the drive unit address)
- Additional items for non-floppy drive mounting panel:
 - Disk drive bracket used with non-floppy drive mounting panel
 - Four rubber grommets
 - Four threaded screws
 - Four 5/16 inch nuts (to secure the bracket to the mounting panel)

Preparing the RZ23/RZ23L/RZ24 Disk Drive Assembly

The RZ23/RZ23L/RZ24 disk drive must be prepared for installation on a non-floppy drive mounting panel. Remove the drive from the preassembled bracket and install the drive to the non-floppy mounting panel bracket. Follow these steps:

1. Remove the four Phillips-head screws securing the bracket to the new drive.
2. Slide the drive out of the bracket.
3. Slide the four rubber grommets into the openings in the sides of the non-floppy bracket.
4. Place the new drive in the bracket with the logic module facing out.
5. Place the bracket (with drive) on its side and align the two screw holes and rubber grommets in the bracket with the two corresponding screw holes in the drive.
6. Screw in two threaded screws.
7. Turn the bracket over, align the two screw holes on that side, and screw in the other two screws.

After any removal/installation, power up the workstation and verify the installation by running self-tests. Enter **test -c** to verify unit select addresses.

Replacing an Internal RZ23/RZ23L/RZ24 Disk Drive

Refer to Figure 3-3 and do the following to remove the disk drive from the mounting panel:

1. Determine where the problem is:
 - The electronics module
 - The HDA - in which case replace the complete drive
2. Remove the cover as described in Removing the System Unit Cover.
3. Disconnect the SCSI cable from the drive by gently pulling the connector straight out.
4. Disconnect the drive power cable from the drive.
5. Remove the drive and bracket from the drive mounting panel by using a 5/16-inch socket wrench to unscrew the nuts from the four studs.
6. Lift the drive and bracket off the studs.

To replace the drive:

1. Verify that the unit select jumpers have the same settings as the original drive. Typical settings are listed in Table 3-3.
2. With the drive connectors facing the back of the system unit, align the four bracket holes over the screw studs on the drive mounting panel. Lower the drive and bracket flush with the drive mounting panel.
3. Using a 5/16-inch socket wrench, screw the nuts onto the four studs.
4. Reconnect the drive power cable.

5. Position the SCSI connector so the **This Side Up** label faces up and/or the connector key faces away from the logic side of the drive assembly. If the disk drive connector is not keyed, position the connector so the solid color wires (red and black) face the power connector socket on the drive unit. Reconnect the SCSI cable to the drive by pushing it into the drive connector.

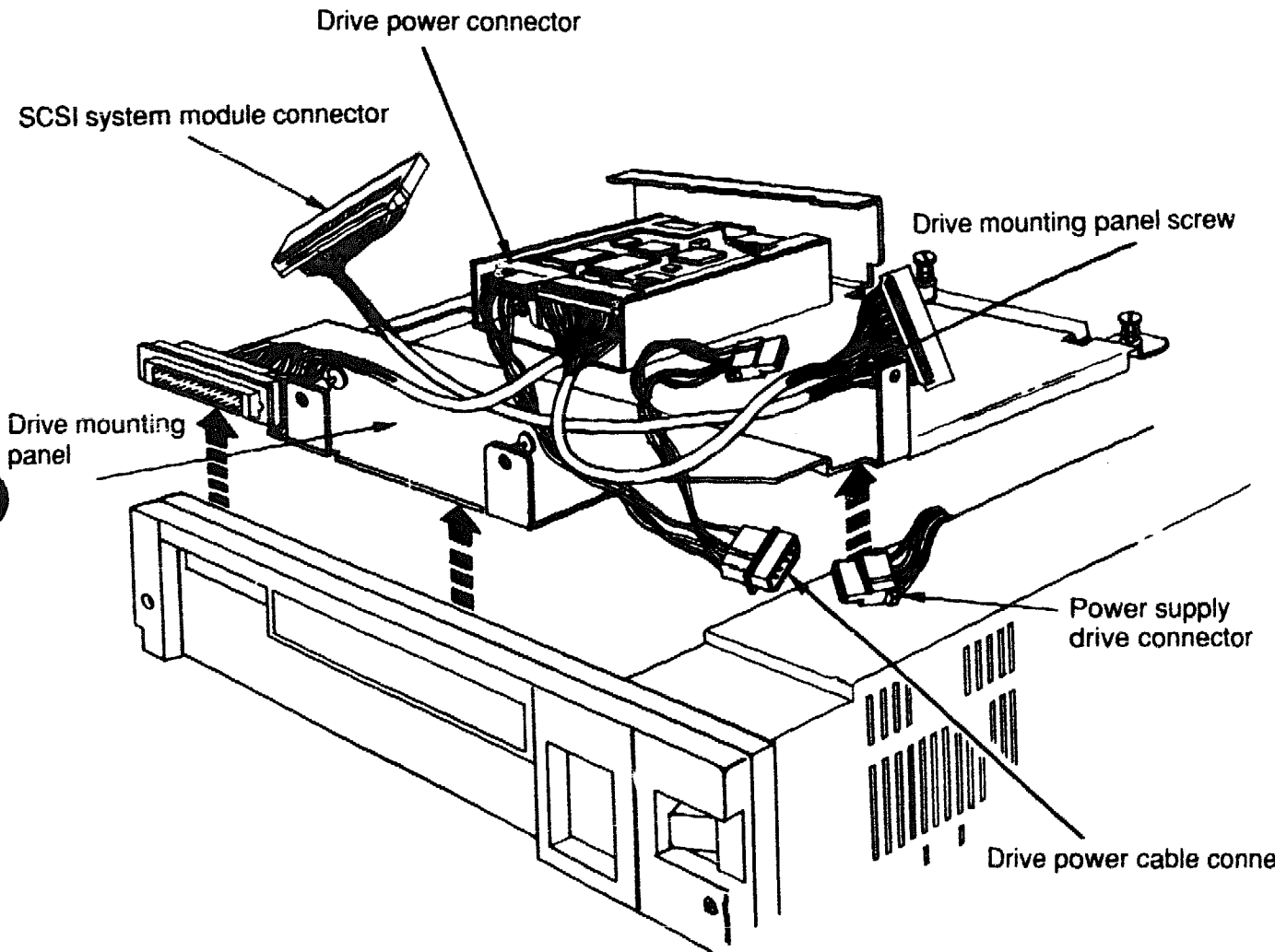

Figure 3-3. Removing an RZ23/RZ23L/RZ24 Disk Drive (Non-Floppy Panel)

Table 3-3. Unit Select Jumper Settings

Device Number	RZ23/RZ23L/RZ24 Jumper Pins			Recommended Device Assignment
	E1	E2	E3	
7	In	In	In	Reserved - not available
6	Out	In	In	Controller - not available
5	In	Out	In	TK50Z or tape
4	Out	Out	In	RX23 ¹ or RRD40
3	In	In	Out	First RZ23/RZ23L/RZ24 - system
2	Out	In	Out	Second RZ23/RZ23L/RZ24
1	In	Out	Out	Available
0	Out	Out	Out	Available

¹For RX23 SCSI ID switches: In = Down, Out = Up.

Installing Add-On RZ23/RZ23L/RZ24 Disk Drives

Before installing an add-on disk drive, do the following steps:

1. Be sure that the system is working properly.
2. Follow the procedures in Chapter 1 to properly shut down worksystem software if required.
3. Enter **test -c** at the keyboard to obtain the current configuration table.
4. Use the configuration table to determine the unit selection address of the disk drive(s) to be installed.
5. Power down the workstation.
6. Prepare the disk drive by following the procedure in Preparing the RZ23/RZ23L/RZ24 Disk Drive Assembly.

Follow these steps to install an add-on RZ23/RZ23L/RZ24 disk drive.

1. Remove the system unit cover as described in Removing the System Unit Cover.
2. Refer to Figure 3-3 to locate the drive power cables and drive SCSI cables.

3. The unit address is determined from the available unit addresses shown on the configuration table and the typical unit select jumper settings shown in Table 3-3.

Remove jumper blocks on pins labeled E1, E2, or E3, located on top of the disk drive electronics module, to select the unit address.

4. With the drive connectors facing the back of the system unit, align the four bracket holes over the screw studs on the drive mounting panel. Lower the drive and bracket flush with the drive mounting panel.
5. Using a 5/16-inch socket wrench, screw the nuts onto the four studs.
6. Connect the drive power cable.
7. Position the SCSI connector with the label showing **This Side Up** facing up and/or with the connector key facing away from the logic side of the drive assembly. If the disk drive connector is not keyed, position the connector so the solid color wires (red and black) face the power connector on the drive unit. Reconnect the SCSI cable to the drive by pushing it into the drive connector.

Power up the workstation and verify the installation by running self-tests. Enter **test -c** to verify unit select addresses.

Disk Drive Replacement: Floppy Mounting Panel

This section describes the floppy mounting panel and how to:

- Replace an RX23 floppy disk drive
- Add-on an RX23 floppy disk drive
- Replace an RZ23/RZ23L/RZ24 hard disk drive
- Add-on an RZ23/RZ23L/RZ24 hard disk drive

For multiple drive installations:

- Install the RX23 floppy drive before installing RZ23/RZ23L/RZ24 drives.
- Disconnect SCSI and power cables after removing drives.
- Connect SCSI and power cables before installing drives.

Note: *Your system must have ULTRIX 3.1 or UWS 2.1 (Rev. 14) or higher to support an RX23 floppy disk drive. Do not install an RX23 floppy drive in a system with a lower version of ULTRIX.*

Note: *Some system drives contain factory-installed software. If you replace a drive that contains factory-installed software, the customer is responsible for reinstalling any software that was on the old drive.*

RX23 Installation Package Contents

The RX23 replacement and add-on disk drive installation package contains the following preassembled items for each disk drive:

- Disk drive assembly (RX23-AA)
- Disk drive bracket (attached to the drive with screws)
- Disk drive SCSI/FDI controller logic module (attached to the bracket with screws)
- One short flat ribbon cable to connect the SCSI/FDI controller to the drive
- Four threaded screw and rubber grommet assemblies (attached to the bottom of the drive bracket)
- Floppy disk drive bezel insert for the system cover
- Two blank floppy diskettes with labels

- Floppy drive mounting panel
- Five-connector SCSI cable with connector keys
- Five-connector power supply cable
- Upgrade EPROMs (2)

RZ23/RZ23L/RZ24 Hard Disk Drive Installation Package Contents

The RZ23/RZ23L/RZ24 replacement and add-on disk drive installation package contains the following items for each disk drive:

- Preassembled for floppy drive mounting panel:
 - Disk drive module
 - Disk drive bracket (with tabs and captive screw)
 - Four 6/32 screws (attaching the bracket to the drive)
 - Jumper blocks (attached) (to select the drive unit address)
- Additional items for non-floppy drive mounting panel:
 - Disk drive brackets used with non-floppy drive mounting panel
 - Four rubber grommets
 - Four threaded screws
 - Four 5/16 inch nuts (to secure the bracket to the mounting panel)

After any removal/installation, power up the workstation and verify the installation by running self-tests. Enter **test -c** to verify unit select addresses.

Refer to Figure 3-4 for a top view of component orientation on the floppy mounting panel, and locate these components:

- Five-connector SCSI cable showing correct connector orientation
- Five-connector power supply cable showing correct connector orientation
- Dashed outlines showing the location of two RZ23/RZ23L/RZ24 drives and one RX23 drive
- Power supply

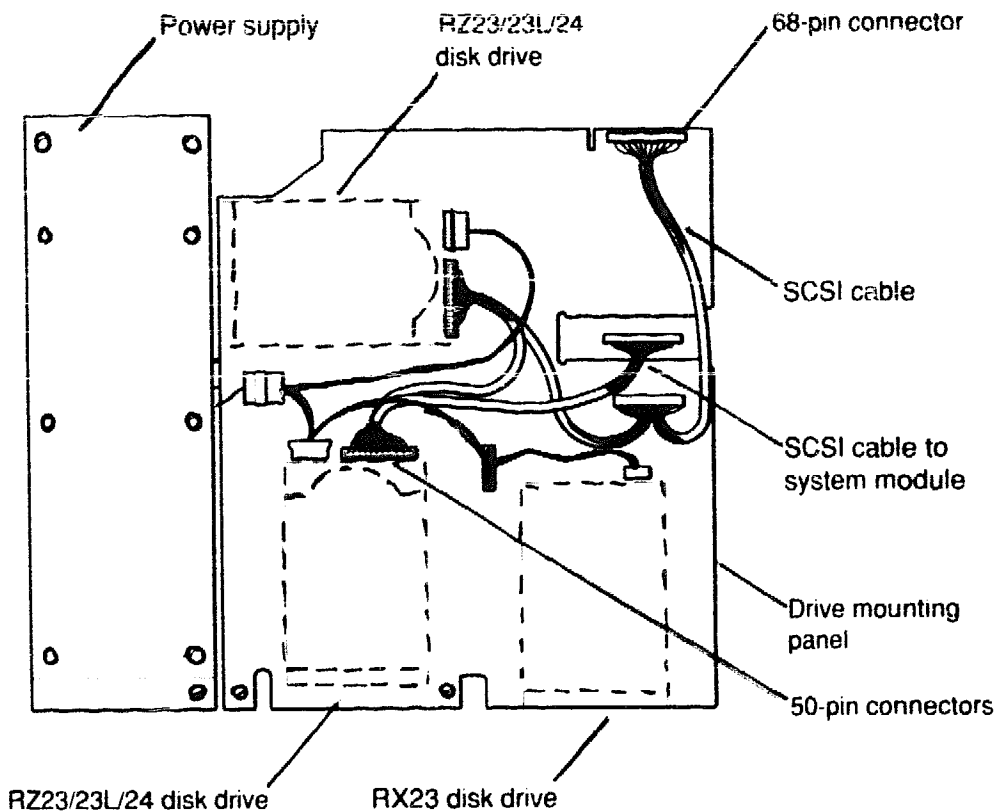

WSE1M001

Figure 3-4. Floppy Mounting Panel Component Location

Replacing an Internal RX23 Disk Drive

Refer to Figure 3-5 and do the following:

1. Remove the cover as described in Removing the System Unit Cover.
2. Remove the drive:
 - Press down and hold the drive panel lever.
 - Slide the drive toward and over the drive panel lever and into the large openings of the keyhole slide mounts.
 - Lift the drive up and away from the mounting panel.
3. Disconnect the SCSI cable from the drive logic module by pushing the connector latches in opposite directions. Then gently pull the connector straight up.
4. Disconnect the drive power cables from the drive and the logic module.

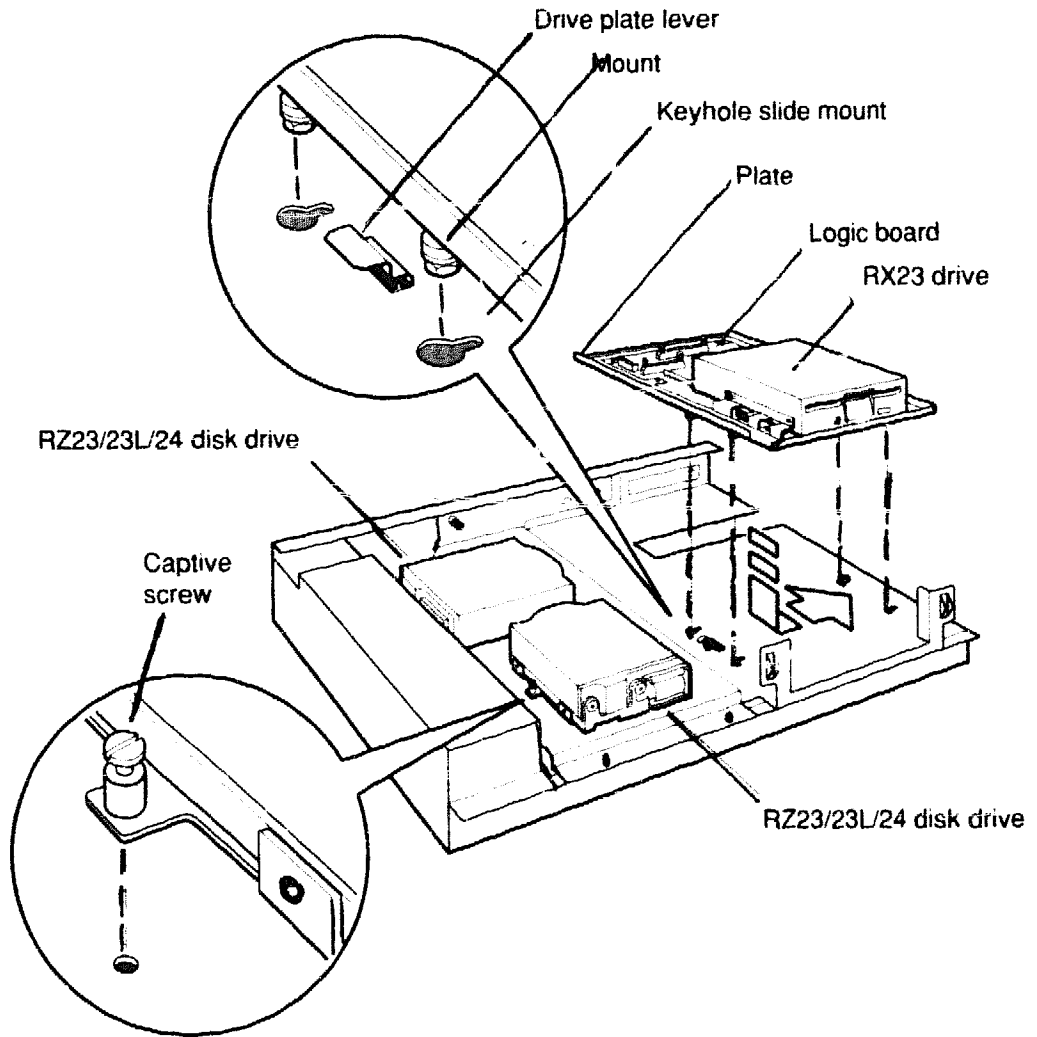

WSE1M005

Figure 3-5. Disk Drive Removal From a Floppy Mounting Panel

To replace the drive:

1. Refer to Figure 3-6 to set the SCSI ID switches to a proper address as shown in the configuration table.

Note: The RX23 Logic Unit Number switch is located on the side of the drive opposite the SCSI ID switches. Be sure this slide switch is in the 0 (zero) position.

2. Connect the SCSI cable to the drive logic board connector with the connector key facing toward the drive.
3. Connect the drive power cables to the drive and the drive logic board.
4. With the drive connectors facing the back of the system unit, align the four mounting grommets over the large openings of the keyhole slide mounts.
5. Press the drive assembly down, holding the drive locking lever down.
6. Push the drive mounting grommets into the keyhole slide mounts.
7. Slide the drive away from the drive locking lever until the lever locks the drive into place.

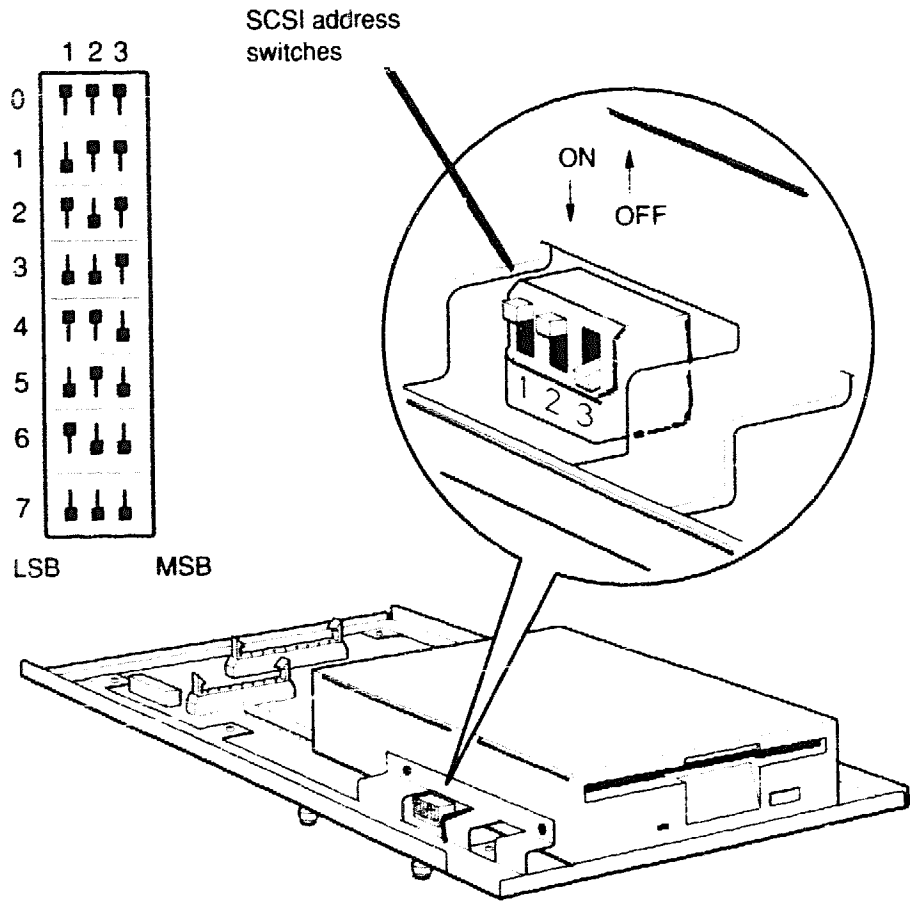

WSF1M003

Figure 3-6. Floppy Disk Drive SCSI ID Switches

Installing an Add-on RX23 Disk Drive

Note: *Your system must have ULTRIX 3.1 or UWS 2.1 (Rev. 14) or higher to support an RX23 floppy drive. Do not install an RX23 in a system with a lower version of ULTRIX.*

Before installing an add-on disk drive, do the following:

1. Be sure that the system is working properly.
2. Follow the procedures in Chapter 1 to properly shut down worksystem software, if required.
3. Enter **test -c** at the keyboard to obtain the current configuration table.
4. Use the configuration table to determine the unit selection address of the disk drive(s) to be installed. Refer to Figure 3-6 to set the SCSI ID switches.

Note: *The RX23 Logic Unit Number switch is located on the side of the drive opposite the SCSI ID switches. Set this slide switch to the 0 (zero) position.*

5. Power down the workstation.

Refer to Figure 3-5 and follow these steps to install an add-on RX23 disk drive.

1. Remove the system unit cover as described in Removing the System Unit Cover.
2. Refer to Figure 3-7 and follow these steps to remove the blank bezel insert from the front of the system cover and install the new floppy drive bezel insert:
 1. Insert a small slot-head screwdriver under the bottom outside edge of the bezel insert.
 2. Gently pry up the bezel and pull it away from the top cover.
 3. Install the floppy bezel insert by pivoting it from the top down until it snaps into place.

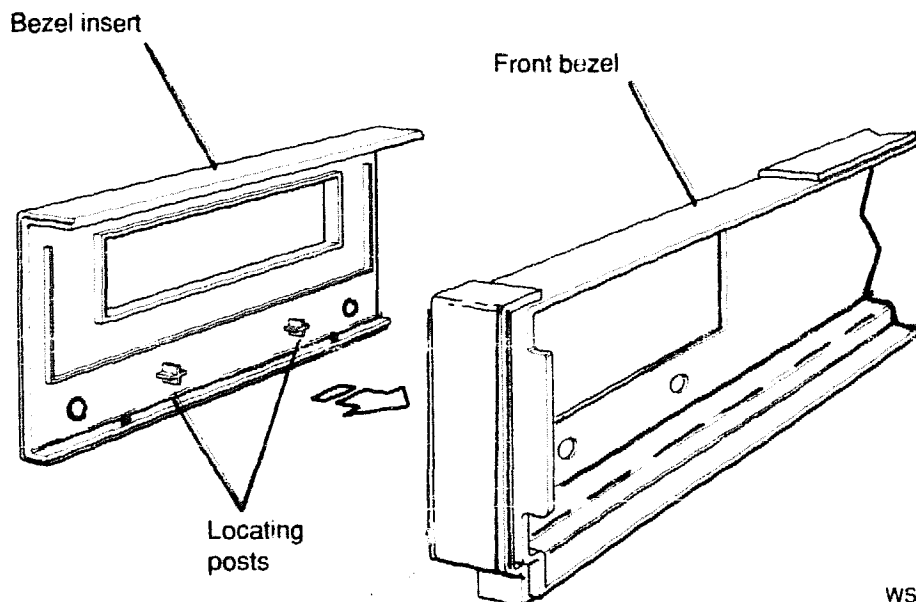

WSE1M004

Figure 3-7. Floppy Disk Drive Bezel Installation

3. Refer to Figure 3-4 to locate:
 - Two power cable connectors, one each for the drive and drive logic module
 - SCSI cable connector, to connect to the drive SCSI/FDI controller logic module
 - The dashed line showing orientation of the RX23 drive
4. Connect the SCSI cable to the drive logic board connector with the connector key facing toward the drive.
5. Connect the drive power cables to the drive and the logic module.
6. With the drive connectors facing the back of the system unit, align the four mounting grommets over the large openings of the keyhole slide mounts.
7. Press the drive assembly down, holding the drive locking lever down.
8. Push the drive mounting grommets into the keyhole slide mounts.
9. Slide the drive away from the drive locking lever until the lever locks the drive into place.

Replacing an RZ23/RZ23L/RZ24 Disk Drive (Floppy Panel)

Refer to Figure 3-5 and do the following:

1. Remove the cover as described in Removing the System Unit Cover.
2. Use a medium-size slot-head screwdriver to loosen the captive screw securing the drive bracket to the mounting panel.
3. Remove the drive by pivoting the drive up and lifting it from the slots in the mounting panel.
4. Disconnect the SCSI cable from the drive by gently pulling the connector straight out.
5. Disconnect the drive power cable from the drive.

To replace the drive:

1. The replaced RZ23/RZ23L/RZ24 disk drive will probably retain the same unit address. If you must change the unit address, find an available unit address in the configuration table. Use the typical unit select jumper settings shown in Table 3-3 to set the unit address.
2. Connect the SCSI cable to the drive logic board connector with the connector key facing away from the logic side of the drive assembly.
3. Connect the drive power cable to the drive.
4. Position the drive mounting bracket tabs over the tab slots in the mounting panel.
5. With the drive oriented properly, tilt the drive assembly so the captive screw faces up, and insert the two tabs on the opposite side of the drive bracket into the two slots in the mounting panel.
6. Pivot the drive assembly down and twist the captive screw clockwise until it is hand tight.
7. Tighten the captive screw with a medium size slot-head screwdriver.

Installing Add-on RZ23/RZ23L/RZ24 Disk Drives (Floppy Panel)

The RZ23/RZ23L/RZ24 installation kit contains mounting brackets used with the non-floppy mounting panel. If you are mounting an RZ23/RZ23L/RZ24 drive on the floppy panel, you do not use these brackets.

Before adding-on an RZ23/RZ23L/RZ24 disk drive

Before installing an add-on disk drive, do the following steps:

1. Be sure that the system is working properly.
2. Follow the procedures in Chapter 1 to properly shut down worksystem software, if required.
3. Enter **test -c** at the keyboard to obtain the current configuration table.
4. Select the unit address.

The unit address is determined from the available unit addresses shown on the configuration table and the typical unit select jumper settings shown in Table 3-3.

Remove jumper blocks on pins labeled E1, E2, or E3 as necessary to match the desired setting shown in Table 3-3. The pins are on top of the disk drive electronics.

5. Power down the workstation.

To install the RZ23/RZ23L/RZ24

Refer to Figure 3-5 and follow these steps to install an add-on RZ23/RZ23L/RZ24 disk drive.

1. Remove the system unit cover as described in Removing the System Unit Cover.
2. Refer to Figure 3-4 to locate:
 - The power cable connector for the drive
 - The SCSI cable connector for the drive
 - The dashed line showing orientation of each RZ23/RZ23L/RZ24 drive
3. Connect the SCSI cable to the drive logic board connector with the connector key facing away from the logic side of the drive assembly.
4. Connect the drive power cable to the drive.
5. With the drive oriented properly, tilt the drive assembly so the captive screw faces up, and insert the two tabs on the opposite side of the drive bracket into the two slots in the mounting panel.
6. Pivot the drive assembly down and twist the captive screw clockwise until it is hand tight.
7. Tighten the captive screw with a medium size slot-head screwdriver.

Replacing D SIM Modules

This procedure assumes the front of the workstation unit is facing you. Refer to Figure 3-8 and do the following:

1. Remove the cover as described in *Removing the System Unit Cover*.
2. Remove the drive mounting panel as described in *Removing the Drive Mounting Panel*.
3. Using a small-blade screwdriver, spread the latches located at each end of the slot connector. This disengages the module from its connector.

Caution: *Be careful not to push the latches too far; the latches will break.*

4. Tilt the module away from you at a 45-degree angle, pulling it slightly until the module comes out of the slot.
5. Note the slot assignment from which you removed the module by looking at the number on the etch to the left of the slot.

To replace a D SIM module:

1. Position the module before inserting it into the slot.
 - a. Orient the module so the notch (module key) is on the bottom left of the module. The set of five chips on the module is closest to the power supply assembly.
 - b. Align the second notch, located halfway on the bottom edge of the module, over a similarly shaped ridge on the slot connector.
2. Engage the connector pins of the D SIM module with the slot connector pins at a 45-degree angle away from you. Making sure the pins remain aligned, press firmly and rock the module slightly toward you until it is upright and snaps into place.

3. Run the main RAM test to verify that memory problem is solved before replacing the drive mounting panel.
4. Replace the drive mounting panel by reversing the procedure in Removing the Drive Mounting Panel.

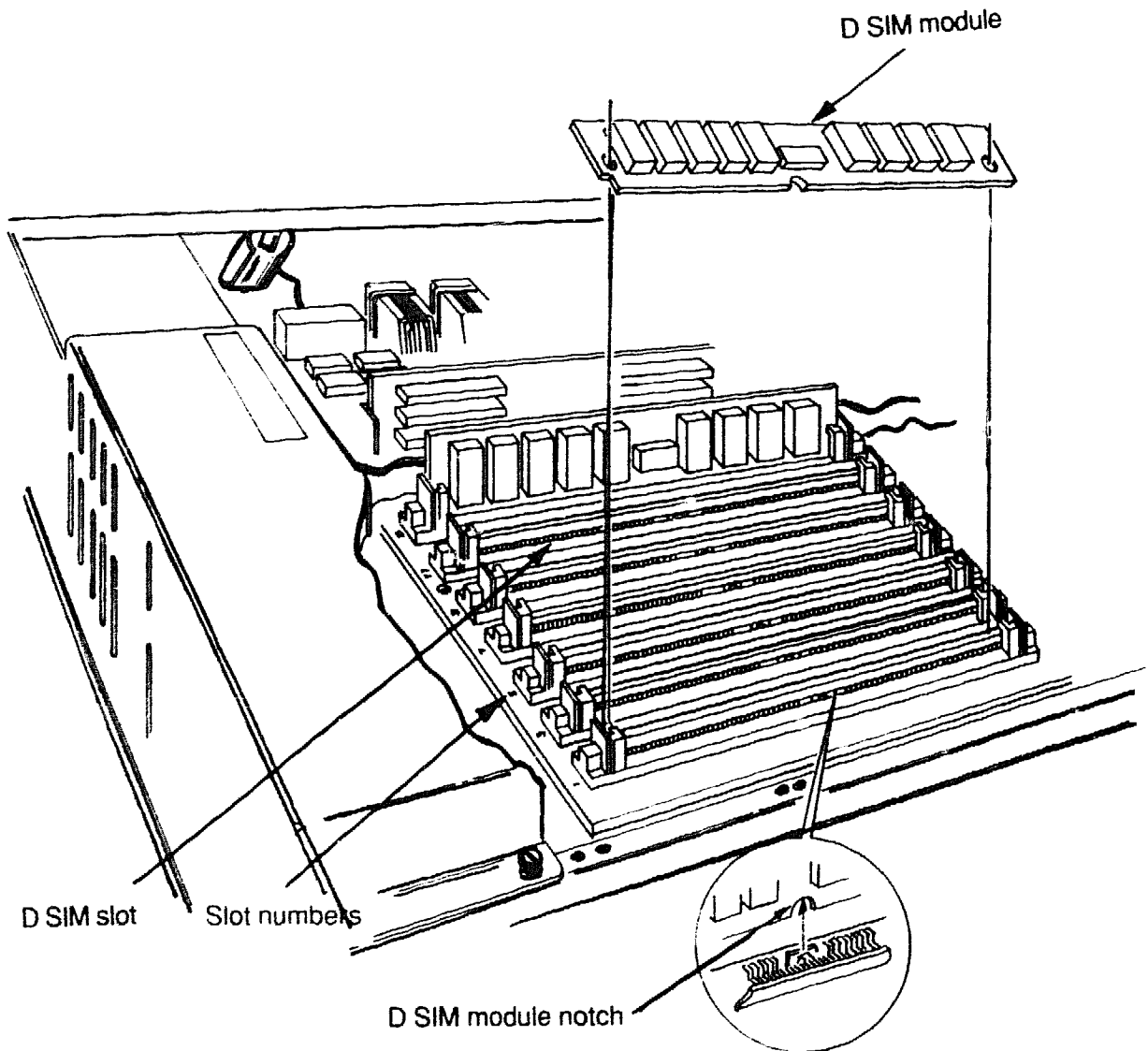

Figure 3-8. Removing a D SIM Module

Installing Add-on D SIM Modules

The add-on memory option is installed in increments of 4-Mbytes and is implemented on two D SIMs. Add-on memory installation considerations include the following:

- Add-on D SIM memory modules are always installed in pairs. (You can replace individual modules that fail.)
- D SIM slot numbers are etched on the system board next to the D SIM connectors as shown in Figure 3-8.
- Slot numbers are etched in two groups; odd numbers 1 to 11, and even numbers 2 to 12.
 - Odd-numbered slots are bits 0-15 plus 2 parity bits.
 - Even-numbered slots are bits 16-31 plus 2 parity bits.

The sequence of installation for each 4-Mbyte module pair is shown in Table 3-4. For example, you install a D SIM module pair in slots 9 and 10 to increase memory capacity from 16 Mbytes to 20 Mbytes.

Before installing add-on D SIM modules, do the following steps:

1. Be sure that the system is working properly.
2. Follow the procedures in Chapter 1 to properly shut down worksystem software if required.
3. Enter **test -c** at the keyboard to verify memory capacity as shown on line one of the configuration display.
4. Power down the workstation.

Follow these steps to install D SIM modules (see Figure 3-8):

1. Face the front of the system unit.
2. Remove the system unit cover as described in Removing the System Unit Cover.
3. Remove the drive mounting panel as described in Removing the Drive Mounting Panel.
4. Insert and test the module pairs as described in To replace a D SIM module.

5. Replace the drive mounting panel by reversing the steps described in Removing the Drive Mounting Panel.
6. Replace the system unit cover by reversing the procedure described in Removing the System Unit Cover.

Table 3-4. D SIM Memory Module Locations

Slot	4-Mbyte Module Pairs ¹					
	4Mb	8Mb	12Mb	16Mb	20Mb	24Mb
1 ²	↔	↔	↔	↔	↔	↔
3	-	↔	↔	↔	↔	↔
5	-	-	↔	↔	↔	↔
7	-	-	-	↔	↔	↔
9	-	-	-	-	↔	↔
11	-	-	-	-	-	↔
2	↔	↔	↔	↔	↔	↔
4	-	↔	↔	↔	↔	↔
6	-	-	↔	↔	↔	↔
8	-	-	-	↔	↔	↔
10	-	-	-	-	↔	↔
12	-	-	-	-	-	↔

¹ ↔ = module inserted in slot

² Odd-numbered slots = 0-15 + 2 parity bits, even-numbered slots = 16-31 + 2 parity bits.

Replacing Video SIM Modules

Use this procedure to replace both the monochrome and color Video SIM modules. The components on the SIM module face the front of the system unit.

This procedure assumes the front of the system unit is facing you. Refer to Figure 3-9 and do the following:

1. Remove the cover as described in Removing the System Unit Cover.
2. Remove the drive mounting panel as described Removing the Drive Mounting Panel.
3. Using a small-blade screwdriver, spread the latches located at each end of the slot connector. This disengages the module from its connector.

Caution: Be careful not to push the latches too far; they will break.

4. Tilt the module away from you at a 45-degree angle, pulling it slightly until the module comes out.

To replace a Video SIM module:

1. Position the module before inserting it into the slot.
 - a. Orient the module so the notch (module key) is on the bottom left of the module.
 - b. Align the second notch, located halfway on the bottom edge of the module, over a similarly shaped ridge on the slot connector.
2. Engage the connector pins of the Video SIM module with the slot connector pins at a 45-degree angle away from you. Making sure the pins remain aligned, press firmly and rock the module slightly toward you until it is upright and snaps into place.
3. Verify the Video SIM problem is solved by running the Video RAM Test before replacing the drive mounting panel.
4. Replace the drive mounting panel by reversing the procedure in Removing the Drive Mounting Panel.

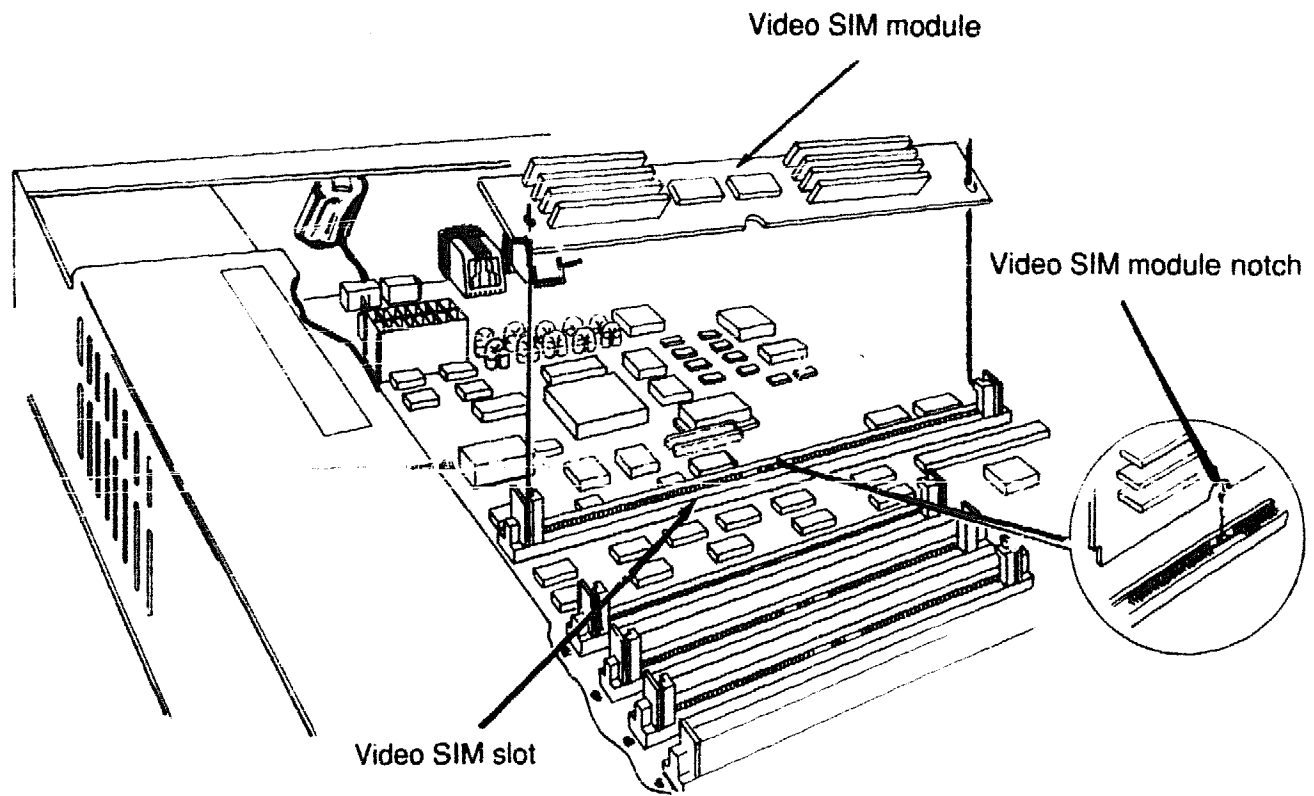

Figure 3-9. Removing the Video SIM Module

Replacing the Battery Pack

Refer to Figure 3-10 and do the following:

1. While the workstation is on, display the Environment Variables Table by typing the `printenv` command at the console prompt. Write down the variable settings.
2. Turn the workstation off.
3. Remove the cover as described in Removing the System Unit Cover.
4. Remove the battery-pack connector from the system module by unplugging it from the system unit connector.
5. Using your fingers or a small-blade screwdriver, pry the battery pack out of its bracket.

To replace the battery pack:

1. Push the battery pack into the bracket.
2. Plug the battery pack connector into the system unit connector.

When finished, turn the DECstation 2100/3100 on and using the `setenv` command, reset the environmental variables as recorded earlier.

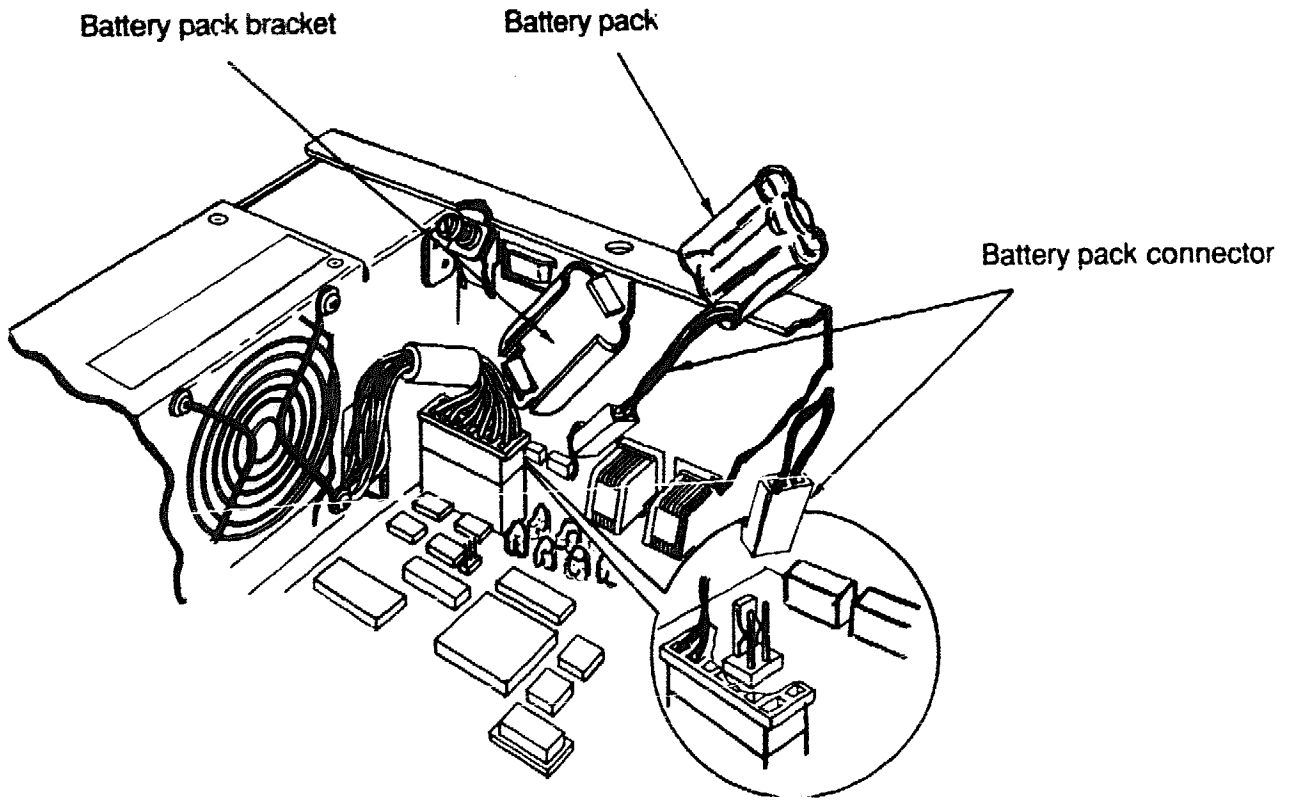

Figure 3-10. Removing the Battery Pack

Replacing the System Module

This procedure assumes the front of the system unit is facing you. Refer to Figure 3-11 and do the following:

1. While the workstation is on, display the Environment Variables Table by typing the `printenv` command at the console prompt. Write down the variable settings.
2. Turn the workstation off.
3. Remove the cover as described in **Removing the System Unit Cover**

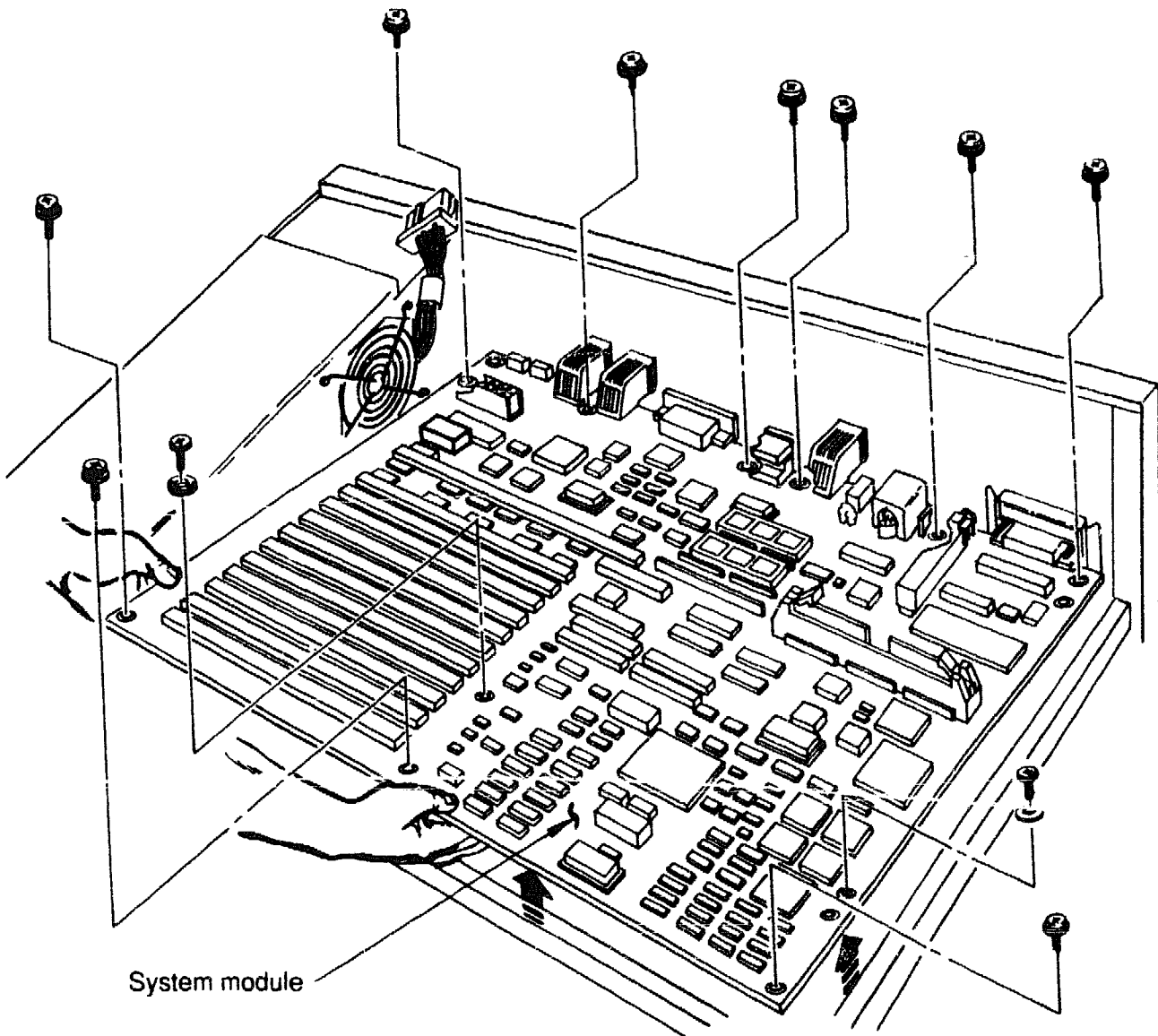

Figure 3-11. Removing the System Module

4. Remove the battery pack connector from the system module as described in Replacing the Battery Pack.
5. Remove the drive mounting panel as described in Removing the Drive Mounting Panel.
6. Remove the 11 Phillips-head screws around the perimeter and in the center of the system module. Note the screws with nylon washers. These washers must be replaced in the same locations.
7. Remove the system module from the chassis by grasping the module with both hands and pulling it off of the two centering points on the chassis' bottom. At the same time, move the module away from you to remove its connectors from the back of the chassis.
8. Using a chip extraction tool, carefully remove the ESAR chip, located behind the Video SIM module.
9. Using a chip extraction tool, carefully remove the ESAR chip from the new system module and replace it with the ESAR chip from the original system module (refer to Figure 3-12 on the next page). The notch on the ESAR chip should be facing the outer side of the system module.

Caution: *Be careful to insert the ESAR chip properly. If you insert the chip backwards, you will damage the chip.*

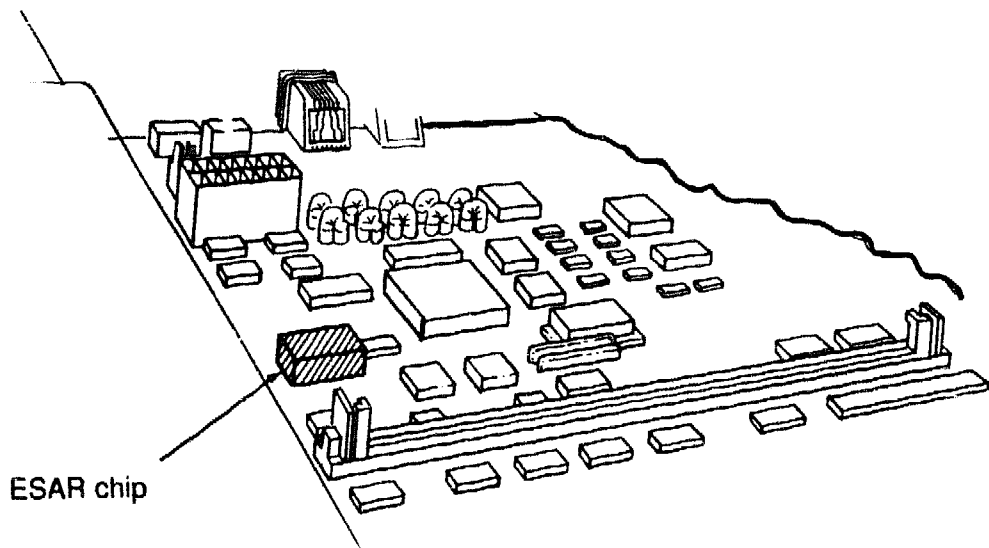

Figure 3-12. ESAR Chip Location

To replace the system module:

1. Reverse steps 7 and 6.
2. Before replacing the drive mounting panel, verify that replacing the system module solved the problem by running the System Test.
3. Reverse steps 5 through 3. When connecting the SCSI cable connector to the system module, push the connector down into the slot until the latches connect.
4. When finished, turn the DECstation 2100/3100 on and reset the environment variables as recorded in step 1 of the removal procedure.
5. If the system has an RX23 floppy drive, the system module requires EPROMs with KN01 Version 7.0 or higher. If the new system module's EPROMs do not have KN01 Version 7.0 or higher, install the original system module's EPROMs on the new system module. To find the system's EPROM version, check the power-up display. Refer to Replacing the System EPROMs for directions on EPROM replacement.

Replacing the System EPROMs

Warning: The NVRAM contents will be lost when the system EPROMs are changed. Be sure you record the environment variable settings before you remove the EPROMs.

Refer to Figure 3-13 and follow these steps:

1. Note the exact position and orientation of both EPROM chips. The notch on the end of each EPROM chip should face the power supply.
2. Using a chip extraction tool, carefully remove both EPROM chips from the new system module.
3. Carefully replace each EPROM with an EPROM from the original system module or a floppy drive upgrade kit. Insert the EPROM marked "LO" nearest the connector edge of the system unit.

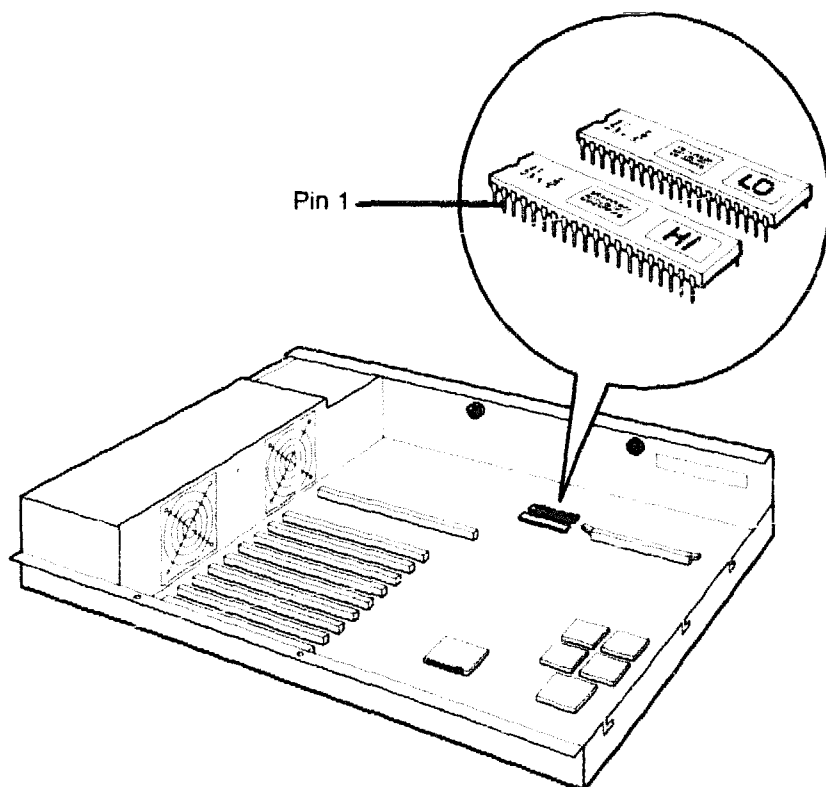

WSE1M007

Figure 3-13. Replacing the System EPROMs

Replacing the Power Supply Assembly

Warning: *Dangerous voltages are present in the power supply assembly. Turn the workstation off and disconnect all power cords before performing this procedure.*

Refer to Figure 3-14 and do the following:

1. Remove the cover as described in Removing the System Unit Cover.
2. Disconnect the drive power cable from the power supply connector.
3. Disconnect the system module power connector from the system module.
4. Remove the two Torx-head screws on the right side of the chassis using a Torx screwdriver.
5. Unfasten the captive screw securing the drive mounting assembly to the power supply assembly.
6. Unfasten the captive screw at each end of the power supply assembly.
7. Remove the power-supply assembly by carefully lifting it up and toward the front of the system unit.

To replace the power supply assembly, reverse the removal procedure in this section.

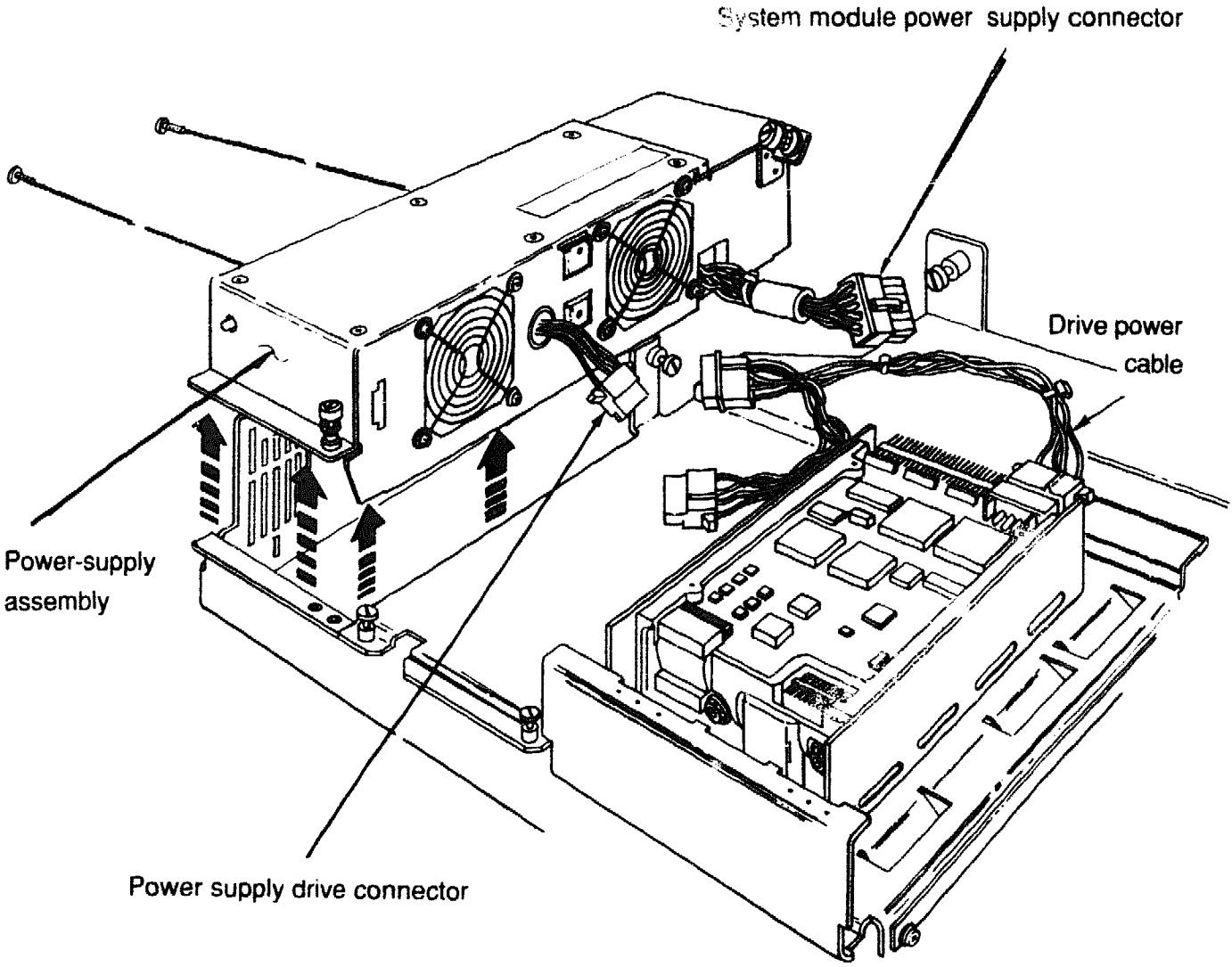

Figure 3-14. Removing the Power Supply Assembly

Equipment Specifications

This appendix lists the physical specifications, operating conditions, and nonoperating conditions for the following items:

- DECstation 2100/3100 Model 200 system unit
- VR150 monitor
- VR160 monitor
- VR262 monitor
- VR297 monitor
- VR299 monitor
- LK201 keyboard
- VSXXX-AA mouse
- RZ55 hard disk drive
- TK50Z tape drive
- TLZ04 cassette tape drive
- RRD40 optical compact disc drive
- RZ23 hard disk drive
- RZ25L hard disk drive
- RZ24 hard disk drive
- RX23 diskette drive

DECstation 2100/3100 System Unit Equipment Specifications

Table A-1. System Unit Description

Weight	17.8 kg (39 lb) maximum
Height	14.99 cm (5.90 in)
Width	46.38 cm (18.26 in)
Depth	40.00 cm (15.75 in)
Input voltage	Auto adjust 100–120 Vac or 220–240 Vac
Input current	2.8 A at 100–120 Vac 1.5 A at 220–240 Vac
Power	
– Frequency	47 to 63 Hz
– Heat dissipation	190 watts, maximum

Table A-2. System Unit Operating Conditions

Temperature range ¹	10°C to 40°C (50°F to 104°F)
Temperature change rate	11°C (52°F) per hour, maximum
Relative humidity	10% to 90%, noncondensing
Maximum wet-bulb temperature	28°C (82°F)
Minimum dew-point temperature	2°C (36°F)
Altitude	2,400 m (8,000 ft) maximum

¹Reduce maximum temperature by 1.8°C for each 1,000 meter (1.0°F for each 1,000 ft) increase in altitude.

Table A-3. System Unit Nonoperating Conditions

Temperature range	–40°C to 66°C (–40°F to 151°F)
Relative humidity	10% to 95% noncondensing
Maximum wet-bulb temperature	46°C (115°F), packaged
Minimum dew-point temperature	2°C (36°F)
Altitude	4,900 m (16,000 ft) maximum

VR150 Monitor Equipment Specifications

Table A-4. VR150 Monitor Description

Weight	16.33 kg (36.00 lb)
Height	39.37 cm (15.50 in)
Width	36.83 cm (14.50 in)
Depth	40.39 cm (15.90 in)
External controls, switches, and indicators	Brightness Contrast Power switch Power indicator
Tilt range	-5° to +13°
Swivel range	±60°
Cathode-ray tube (CRT)	381 mm (15 in) diagonal flat square Monochrome Paper-white phosphor High-efficiency antiglare treatment
Display characteristics	1,024 pixels horizontal by 864 lines vertical Approximate picture size 240 by 203 mm Maximum brightness no less than 30 footlamberts (f)
Video input	
- Termination	75 ohms BNC
- Amplitude	1.0 V _{pp} composite video
- Coupling	ac with ±1.0 V dc offset
Horizontal rate timing	
- Active video time	14.8 μs
- Back porch	1,680 ns
- Blanking interval	3.70 μs maximum
- Frequency timing	54.054 kHz
- Front porch	160 ns
- Horizontal period	18.5 μs
- Pixels displayed	1,024
- Sync pulse	1,850 ns

(continued on next page)

Table A-4 (Cont.). VR150 Monitor Description

Vertical rate timing	
- Active video time	16.0 ms
- Blanking interval	37 horizontal lines
- Frequency	60 Hz
- Front porch	0 horizontal lines
- Lines displayed	864
- Sync pulse	3 horizontal lines
- Vertical period	16.67 ms
Video rate	
- Pixel frequency	69.189 MHz
- Pixel period	14.45 ns nominal
Power	
- ac input voltage	88-132 Vac or 185-264 Vac Auto selectable
- Frequency	47 to 63 Hz
- Power consumption	70 watts nominal

Table A-5. VR150 Monitor Operating Conditions

Temperature range ¹	10°C to 40°C (50° to 104°F)
Relative humidity	10% to 95% noncondensing
Maximum wet-bulb temperature	32°C (89°F)
Minimum dew-point temperature	2°C (36°F)
Altitude	2,400 m (8,000 ft) maximum

¹Reduce maximum temperature by 1.8°C for each 1,000 meter (1.0°F for each 1,000 ft) increase in altitude.

Table A-6. VR150 Monitor Nonoperating Conditions

Temperature range	-40°C to 66°C (-40°F to 150°F)
Relative humidity	10% to 95% noncondensing
Maximum wet-bulb temperature	46°C (115°F) packaged
Altitude	4,900 m (16,000 ft) maximum

VR160 Monitor Equipment Specifications

Table A-7. VR160 Monitor Description

Weight	23.13 kg (51.00 lb)
Height	39.37 cm (15.50 in)
Width	36.83 cm (14.50 in)
Depth	45.72 cm (18.00 in)
External controls, switches, and indicators	Brightness Contrast Degauss Power switch Power indicator
Swivel range	$\pm 60^\circ$
Tilt range	-7° to $+16^\circ$
Cathode-ray tube (CRT)	381 mm (15 in) diagonal Color Medium persistence P22 RGB phosphor 0.28 pitch shadow mask High-efficiency antiglare treatment
Display characteristics	1,024 pixels horizontal by 864 lines vertical approximate picture size 240 mm by 203 mm Maximum brightness no less than 30 footlamberts (fl)
Video input	
– Termination	75 ohms BNC
– Amplitude	Red: 0.7 Vpp Green (with sync): 1 Vpp Blue: 0.7 Vpp
Horizontal rate timing	
– Active video time	14.8 μ s
– Back porch	1,680 ns
– Blanking interval	3.70 μ s maximum
– Frequency timing	54.054 kHz
– Front porch	160 ns
– Horizontal period	18.5 μ s

(continued on next page)

Table A-7 (Cont.). VR160 Monitor Description

- Fixels displayed	1,024
- Sync pulse	1,850 ns
Vertical rate timing	
- Active video time	16.0 ms
- Blanking interval	37 horizontal lines
- Frequency	60 Hz
- Front porch	0 horizontal lines
- Lines displayed	864
- Sync pulse	3 horizontal lines
- Vertical period	16.67 ms
Video rate	
- Pixel frequency	69.189 MHz
- Pixel period	14.45 ns nominal
Power	
- Voltage range (switch selectable)	DA model, 88 to 132 Vac D3, D4 models, 185 to 264 Vac
- Frequency	47 to 63 Hz
- Power consumption	125 watts per 200 VA nominal 150 watts per 250 VA maximum

Table A-8. VR160 Monitor Operating Conditions

Temperature range ¹	10°C to 40°C (50° to 104°F)
Relative humidity	10% to 95% noncondensing
Maximum wet-bulb temperature	32°C (89°F)
Minimum dew-point temperature	2°C (36°F)
Altitude	2,400 m (8,000 ft) maximum

¹Reduce maximum temperature by 1.8°C for each 1,000 meter (1.0°F for each 1,000 ft) increase in altitude.

Table A-9. VR160 Monitor Nonoperating Conditions

Temperature range	-40°C to 66°C (-40°F to 151°F)
Relative humidity	10% to 95% noncondensing
Maximum wet-bulb temperature	46°C (115°F) packaged
Altitude	4,900 m (16,000 ft) maximum

VR262 Monitor Equipment Specifications

Table A-10. VR262 Monitor Description

Weight	19.05 kg (42.00 lb)
Height	39.37 cm (15.50 in)
Width	45.47 cm (17.90 in)
Depth	39.12 cm (15.40 in)
External controls, switches, and indicators	Brightness Contrast Power switch Power indicator
Cathode-ray tube (CRT)	483 mm (19 in) diagonal Monochrome Paper-white phosphor High-efficiency antiglare treatment
Display characteristics	1,024 pixels horizontal by 864 pixels vertical Approximate picture size 334 by 282 mm Maximum brightness no less than 30 footlamberts (fl)
Video input	
– Termination	75 ohms BNC
– Amplitude	1.0 V _{pp} composite video
Horizontal rate timing	
– Active video time	14.8 μ s
– Back porch	1,690 ns
– Blanking interval	3.70 μ s maximum
– Frequency	54.054 kHz
– Front porch	160 ns
– Horizontal period	18.5 μ s
– Pixels displayed	1,024
– Sync pulse	1,850 ns
Vertical rate timing	
– Active video time	16.0 ms
– Blanking interval	37 horizontal lines maximum

(continued on next page)

Table A-10 (Cont.). VR262 Monitor Description

- Frequency	60 Hz
- Front porch	0 horizontal lines
- Lines displayed	864
- Sync pulse	3 horizontal lines
- Vertical period	16.67 ms
Power	
- Power supply type	Transistor, switch mode ac to dc converter
- ac input	100-120 Vac or 220-240 Vac Switch selectable
- Frequency	47 to 63 Hz
- Power consumption	Approximately 65 watts
Fuse	
	100-120 Vac: 1 A 6.35 by 31.8 mm (0.25 by 1.25 in) slow blow (Digital part number 90-07212-00)
	220 to 240 Vac: 1 A 5 by 20 mm time lag (Digital part number 12-19283-00)

Table A-11. VR262 Monitor Operating Conditions

Temperature range ¹	10°C to 40°C (50°F to 104°F)
Temperature change rate	11° (52°F) per hour maximum
Relative humidity	10% to 90% noncondensing
Maximum wet-bulb temperature	28°C (82°F)
Minimum dew-point temperature	2°C (36°F)
Altitude	2,400 m (8,000 ft) maximum

¹Reduce maximum temperature by 1.8°C for each 1,000 meter (1.0°F for each 1,000 ft) increase in altitude.

Table A-12. VR262 Monitor Nonoperating Conditions

Temperature range	-40°C to 66°C (-40°F to 151°F)
Relative humidity	10% to 95% noncondensing
Maximum wet-bulb temperature	46°C (115°F) packaged
Altitude	4,900 m (16,000 ft) maximum

VR297 Monitor Equipment Specifications

Table A-13. VR297 Monitor Description

Weight	29.03 kg (64.00 lb)
Height	40.64 cm (16.00 in)
Width	40.64 cm (16.00 in)
Depth	45.07 cm (17.75 in)
External controls, switches, and indicators	Contrast Power switch Power indicator V-STAT, H-STAT, V-CENT
Tilt range	-5° to 15°
Swivel range	±60°
Cathode-ray tube (CRT)	432 mm (17 in) diagonal Color 0.26 mm phosphor pitch aperture grill 90° deflection High-efficiency antiglare treatment
Display characteristics	1,024 pixels horizontal by 864 pixels vertical Maximum brightness no less than 30 footlamberts (fl)
Video input	
- Termination	75 ohms BNC
- Amplitude	Red: 0.7 V _{pp} Green (with sync): 1 V _{pp} Blue: 0.7 V _{pp}
Horizontal rate timing	
- Active video	14.8 μs
- Back porch	1,680 ns
- Blanking interval	3.70 μs
- Frequency	54.054 kHz
- Front porch	160 ns
- Sync pulse	1.850 μs
Vertical rate timing	
- Active video	16.0 ms

(continued on next page)

Table A-13 (Cont.). VR297 Monitor Description

- Blanking interval	37 lines
- Frequency	60 Hz
- Front porch	0 lines
- Sync pulse	3 lines
- Vertical period	16.67 ms
Video rate	
- Pixel frequency	69.189 MHz
- Pixel period	14.45 ns nominal
Power	
- ac input	110-120 or 220-240 Vac Switch selectable
- Frequency	47 to 63 Hz
Fuse	100-120 V for VR297-DA Domestic 220-240 V for VR297-D3 Northern Hemisphere

Table A-14. VR297 Monitor Operating Conditions

Temperature range ¹	10°C to 40°C (50°F to 104°F)
Relative humidity	10% to 90% noncondensing
Maximum wet-bulb temperature	28°C (82°F)
Minimum dew-point temperature	2°C (36°F)
Altitude	2600 m (10,000 ft) maximum

¹Reduce maximum temperature by 1.8°C for each 1,000 meter (1.0°F for each 1,000 ft) increase in altitude.

Table A-15. VR297 Monitor Nonoperating Conditions

Temperature range	-40°C to 66°C (-40°F to 151°F)
Relative humidity	10% to 95% noncondensing
Maximum wet-bulb temperature	46°C (115°F) packaged
Altitude	13,000 m (50,000 ft) maximum

VR299 Monitor Equipment Specifications

Table A-16. VR299 Monitor Description

Weight	31.75 kg (70.00 lbs)
Height	46.99 cm (18.50 in)
Width	50.55 cm (19.90 in)
Depth	52.58 cm (20.70 in)
External controls, switches, and indicators	Brightness Contrast Degauss Power switch Power indicator Voltage selector switch
Swivel range	$\pm 120^\circ$
Tilt range	-5° to $+15^\circ$
Cathode-ray tube (CRT)	Color 508 mm (20 in) diagonal Medium persistence P22 RGB phosphor 0.32 mm pitch shadow mask High-efficiency antiglare treatment
Display characteristics	1,024 pixels horizontal by 864 pixels vertical Approximate picture size 326 by 275 mm Contrast 35 footlamberts (fl) maximum
Video input	
- Termination	75 ohms BNC
- Amplitude	Red: 0.7 Vpp Green (with sync): 1 Vpp Blue: 0.7 Vpp
Horizontal rate timing	
- Active video time	14.8 μ s
- Back porch	1,680 ns
- Blanking interval	3.69 μ s maximum
- Frequency timing	54.054 kHz
- Front porch	159 ns
- Horizontal period	18.5 μ s

(continued on next page)

Table A-16 (Cont.). VR299 Monitor Description

- Sync pulse	1,850 ns
Vertical rate timing	
- Active video time	16.0 ms
- Blanking interval	37 horizontal lines
- Frequency	60 Hz
- Front porch	0 horizontal lines
- Sync pulse	3 horizontal lines
- Vertical period	16.67 ms
Power	
- ac input voltage	Switch selectable 88-132 Vac or 185-254 Vac
- Frequency	47 to 63 Hz
- Power consumption	150 watts maximum
Fuse	
	3.2 A for 120 V system 1.6 A for 240 V system

Table A-17. VR299 Monitor Operating Conditions

Temperature range ¹	10°C to 40°C (50° to 104°F)
Relative humidity	10% to 95% noncondensing
Maximum wet-bulb temperature	32°C (89°F)
Minimum dew-point temperature	2°C (36°F)
Altitude	2,400 m (8,000 ft) maximum

¹Reduce maximum temperature by 1.8°C for each 1,000 meter (1.0°F for each 1,000 ft) increase in altitude.

Table A-18. VR299 Monitor Nonoperating Conditions

Temperature range	-40°C to 66°C (-40°F to 150°F)
Relative humidity	10% to 95% noncondensing
Maximum wet-bulb temperature	46°C (115°F) packaged
Altitude	4,900 m (16,000 ft) maximum

LK201 Keyboard Equipment Specifications

Table A-19. LK201 Keyboard Description

Weight	2.04 kg (4.50 lb)
Height	5.08 cm (2.00 in)
Width	53.34 cm (21.00 in)
Depth	17.15 cm (6.75 in)
Number of keys	105
Number of indicators	4 status LEDs
Language variations	15 Software selectable (keycaps required)
Cable	1.8 m (6 ft) uncoiled length detachable 4-pin mmj connector at both ends
Baud rate	4800
Electrical interface	EIA RS 423
Power consumption	4.2 watts maximum
Power input	11.8 V \pm 6% at 350 ma
Volume control	8 levels, plus off Maximum 65 dba 1 ft above keyboard
Keystroke timing	20 ms minimum

Table A-20. LK201 Keyboard Operating Conditions

Temperature range ¹	10°C to 40°C (50°F to 104°F)
Relative humidity	10% to 90%
Maximum wet-bulb temperature	28°C (82°F)
Minimum dew-point temperature	2°C (36°F)
Altitude	2,400 m (8,000 ft) maximum

¹Reduce maximum temperature by 1.8°C for each 1,000 meter (1.0°F for each 1,000 ft) increase in altitude.

Table A-21. LK201 Keyboard Nonoperating Conditions

Temperature range	-40°C to 66°C (-40°F to 151°F)
Relative humidity	10% to 95%, noncondensing
Maximum wet-bulb temperature	46°C (115°F), packaged
Altitude	4,900 m (16,000 ft) maximum

VSXXX-AA Mouse Equipment Specifications

Table A-22. VSXXX-AA Mouse Description

Weight	0.82 kg (0.37 lb)
Height	39.9 mm (1.57 in)
Diameter	88.9 mm (3.50 in)
Buttons	3
Cable length	1.5 m (5 ft) shielded, 6 conductors and terminals in a 7-pin micro-DIN-type connector (male)
Accuracy	$\pm 3\%$ 0 to 24.5 cm (0 to 10 in) per second in any direction $\pm 15\%$ 24.5 to 49 cm (10 to 20 in) per second in any direction $\pm 30\%$ 49 to 73.5 cm (20 to 30 in) per second in any direction
Baud rate	4800
Data format	Delta binary
Electrical interfaces	EIA RS-232-C or TTL
Operating modes	Incremental or polling
Power requirements	+5 V $\pm 5\%$ at 130 ma -12 V $\pm 10\%$ at 20 ma
Resolution	79 counts per cm (200 counts per in)
Tracking speed	73.5 cm (30 in) per second
Tracking rate	In incremental mode: 55 reports per second In polling mode: up to 95 reports per second

Table A-23. VSXXX-AA Mouse Operating Conditions

Temperature range ¹	10°C to 40°C (50°F to 104°F)
Relative humidity	10% to 90% noncondensing
Maximum wet-bulb temperature	28°C (82°F)
Minimum dew-point temperature	2°C (36°F)
Altitude	2,400 m (8,000 ft) maximum

¹Reduce maximum temperature by 1.8°C for each 1,000 meter (1.0°F for each 1,000 ft) increase in altitude.

Table A-24. VSXXX-AA Mouse Nonoperating Conditions

Temperature range	40°C to 66°C (40°F to 151°F)
Relative humidity	5% to 95% noncondensing
Maximum wet-bulb temperature	46°C (115°F) packaged
Altitude	4,900 m (16,000 ft) maximum

RZ55 SCSI Hard Disk Drive Equipment Specifications

Table A-25. RZ55 SCSI Hard Disk Drive Description

Expansion box	
- Weight	13.15 kg (29.00 lb)
- Height	13.97 cm (5.50 in)
- Width	32.39 cm (12.75 in)
- Depth	28.55 cm (11.25 in)
Internal drive	
- Weight	3.81 kg (8.40 lb)
- Height	8.26 cm (3.25 in)
- Width	14.61 cm (5.75 in)
- Depth	20.83 cm (8.20 in)
Capacity	
- Bytes per drive	332.3 MB
- Blocks per drive	649,040
- Block size	512 bytes
Data transfer rate	
- Bus asynchronous mode	1.5 MB per second
- Bus synchronous mode	4 MB per second
- To and from media	1.25 MB per second
Seek time	
	4 ms track-to-track
	16 ms average
	35 ms maximum
Average latency	8.3 ms
Interface	SCSI

Table A-26. RZ55 SCSI Hard Disk Drive Operating Conditions

Temperature range ¹	10°C to 55°C (50°F to 131°F)
Temperature change rate	11°C (20°F) per hour, maximum
Relative humidity	20% to 80% noncondensing
Maximum wet-bulb temperature	25.6°C (78°F)
Minimum dew-point temperature	2°C (36°F)
Altitude	-300 to 4600 m (-1000 ft to 15,000 ft)

¹Reduce maximum temperature by 1.8°C for each 1,000 meter (1.0°F for each 1,000 ft) increase in altitude.

Table A-27. RZ55 SCSI Hard Disk Drive Nonoperating Conditions

Temperature range	-40°C to 66°C (-40°F to 151°F)
Temperature change rate	20°C (36°F) per hour, maximum
Relative humidity	20% to 95% packaged
Maximum wet-bulb temperature	46°C (115°F) packaged
Altitude	-300 to 12,200 m (-1000 ft to 40,000 ft)

TK50Z Tape Drive Equipment Specifications

Table A-28. TK50Z Tape Drive Description

Expansion box	
- Weight	12.70 kg (28.00 lb)
- Height	13.97 cm (5.50 in)
- Width	32.39 cm (12.75 in)
- Depth	28.58 cm (11.25 in)
Bit density	6,667 bits per in
Cartridge capacity	95 MB approximate
Frequency	50 to 60 Hz
Heat dissipation	32 watts maximum
Input current	2.4 A: 100 to 120 Vac 1.3 A: 220 to 240 Vac
Media	12.77 mm (0.5 in), 183 m (600 ft) long magnetic tape
Mode of operation	Streaming
Number of tracks	22
Power	160 watts
Track format	Serpentine
Data transfer rate	360 Kbits per second (45 KB per second)
Tape speed	75 in per second

Table A-29. TK50Z Tape Drive Operating Conditions

Temperature range ¹	10°C to 40°C (50°F to 104°F)
Temperature change rate	11°C (20°F) per hour, maximum
Relative humidity	10% to 80% noncondensing
Maximum wet-bulb temperature	28°C (82°F)
Minimum dew-point temperature	2°C (36°F)
Altitude	2,400 m (8,000 ft) maximum

¹Reduce maximum temperature by 1.8°C for each 1,000 meter (1.0°F for each 1,000 ft) increase in altitude.

Table A-30. TK50Z Tape Drive Nonoperating Conditions

Temperature range	-30°C to 66°C (-22°F to 151°F)
Temperature change rate	20°C (36°F) per hour, maximum
Relative humidity	10% to 95% noncondensing
Maximum wet-bulb temperature	46°C (115°F) packaged
Altitude	9,140 m (30,000 ft) maximum

TLZ04 Cassette Tape Drive Equipment Specifications

Table A-31. TLZ04 Cassette Tape Drive Description

Expansion box	
- Weight	7.7 kg (17.00 lb)
- Height	11.50 cm (4.5 in)
- Width	35.00 cm (13.00 in)
- Depth	30.00 cm (12.00 in)
Cassette capacity	1.2 gigabyte
Drive interface	SCSI
Media	TLZ04-CA cassette tape
Mode of operation	Streaming and start/stop
Power consumption	230 watts
Power requirements	1.6 A: 100 to 120 Vac 1.0 A: 200 to 240 Vac
Track format	Digital data storage (DDS)
Transfer rate	156 KB per second

Table A-32. TLZ04 Cassette Tape Drive Operating Conditions

Temperature range ¹	10°C to 40°C (50°F to 104°F)
Relative humidity	20% to 80% noncondensing
Altitude	0 m to 4600 m (0 to 15,000 ft)

¹Reduce maximum temperature by 1.8°C for each 1,000 meter (1.0°F for each 1,000 ft) increase in altitude.

Table A-33. TLZ04 Cassette Tape Drive Nonoperating Conditions

Temperature range	-40°C to 70°C (40°F to 158°F)
Relative humidity	5% to 95% noncondensing
Altitude	0 m to 15,200 m (0 to 50,000 ft)

RRD40 Compact Disc Drive Equipment Specifications

Table A-34. RRD40 Compact Disc Drive Description (Tabletop)

Weight	3.99 kg (8.80 lb)
Height	7.62 cm (3.00 in)
Width	23.19 cm (9.13 in)
Depth	27.94 cm (11.00 in)
Access time	Maximum 1,000 ms, including latency Average 500 ms
Average latency	155 ms at outer track 60 ms at inner track
Average transfer rate	175.2 KB per second
Capacity per disc	635 MB
Heat dissipation	14 watts (typical)
Initialization startup time	Less than 6 second
Interface	SCSI

Table A-35. RRD40 Compact Disc Drive Operating Conditions (Tabletop)

Temperature range ¹	10°C to 50°C (50°F to 122°F)
Relative humidity	10% to 80% noncondensing
Maximum wet-bulb temperature	28°C (82°F)
Minimum dew-point temperature	2°C (36°F)
Altitude	3400 m (11,150 ft) maximum

¹Reduce maximum temperature by 1.8°C for each 1,000 meter (1.0°F for each 1,000 ft) increase in altitude.

Table A-36. RRD40 Compact Disc Drive Nonoperating Conditions (Tabletop)

Temperature range	4°C to 70°C (40°F to 158°F)
Relative humidity	5% to 95% noncondensing
Maximum wet-bulb temperature	46°C (115°F) packaged
Minimum dew-point temperature	2°C (36°F)
Altitude	13,600 m (44,600 ft) maximum

RZ23 SCSI Hard Disk Drive Equipment Specifications

Table A-37. RZ23 SCSI Hard Disk Drive Description

Internal drive	
- Weight	0.83 kg (1.82 lb)
- Height	42.16 cm (1.66 in)
- Width	10.16 cm (4.00 in)
- Depth	14.61 cm (5.75 in)
Capacity	
- Bytes per drive	104 MB
- Blocks per drive	204,864
- Block size	512 bytes
Data transfer rate	
- To and from media	1.25 MB per second
- To and from buffer	1.66 MB per second
Seek time	
	8 ms track-to-track
	25 ms average
	45 ms maximum
Average latency	8.4 ms
Interface	SCSI

Table A-38. RZ23 SCSI Hard Disk Drive Operating Conditions

Temperature range ¹	10°C to 60°C (50°F to 140°F)
Temperature change rate	11°C (20°F) per hour, maximum
Relative humidity	8% to 80% noncondensing
Maximum wet-bulb temperature	26°C (78°F)
Minimum dew-point temperature	2°C (36°F)
Altitude	-300 to 3000 m (-1000 to 10,000 ft)

¹Reduce maximum temperature by 1.8°C for each 1,000 meter (1.0°F for each 1,000 ft) increase in altitude.

Table A-39. RZ23 SCSI Hard Disk Drive Nonoperating Conditions

Temperature range	-40°C to 66°C (-40°F to 151°F)
Temperature change rate	20°C (36°F) per hour, maximum
Relative humidity	8% to 95% packaged
Maximum wet-bulb temperature	46°C (115°F) packaged
Altitude	-300 m to 12,200 m (-1,000 ft to 40,000 ft)

RZ23L SCSI Hard Disk Drive Equipment Specifications

Table A-40. RZ23L SCSI Hard Disk Drive Description

Internal drive	
Weight	0.54 kg (1.20 lb)
Height	2.54 cm (1.00 in)
Width	10.16 cm (4.00 in)
Depth	14.61 cm (5.75 in)
Capacity	
– Bytes per drive	121.65 MB
– Blocks per drive	237,588
– Block size	512 bytes
Data transfer rate	
– Bus asynchronous mode	3.0 MB per second
– Bus synchronous mode	4.0 MB per second
– To and from media	1.5 MB per second
Seek time	
	8 ms track-to-track
	19 ms average
	35 ms maximum
Average latency	8.8 ms
Interface	SCSI

Table A-41. RZ23L SCSI Hard Disk Drive Operating Conditions

Temperature range ¹	10°C to 55°C (50°F to 128°F)
Temperature change rate per hour, maximum)	11°C (20°F)
Relative humidity	8% to 80% noncondensing
Maximum wet-bulb temperature	26°C (78°F)
Minimum dew-point temperature	2°C (36°F)
Altitude	–300 to 4600 m (–1000 to 15,000 ft)

¹Reduce maximum temperature by 1.8°C for each 1,000 meter (1.0°F for each 1,000 ft) increase in altitude.

Table A-42. RZ23L SCSI Hard Disk Drive Nonoperating Conditions

Temperature range	-40°C to 66°C (-40°F to 151°F)
Temperature change rate per hour, maximum)	20°C (36°F)
Relative humidity	8% to 95% packaged, noncondensing
Maximum wet-bulb temperature	46°C (115°F) packaged
Altitude	-300 to 12,200 m (-1,000 to 40,000 ft)

RZ24 SCSI Hard Disk Drive Equipment Specifications

Table A-43. RZ24 SCSI Hard Disk Drive Description

Internal drive	
- Weight	0.77 kg (1.70 lb)
- Height	4.14 cm (1.63 in)
- Width	10.16 cm (4.00 in)
- Depth	14.61 cm (5.75 in)
Capacity	
- Bytes per drive	209.7 MB
- Blocks per drive	409,802
- Block size	512 bytes
Data transfer rate	
- Bus asynchronous mode	3.0 MB per second
- Bus synchronous mode	4.0 MB per second
- To and from media	1.5 MB per second
Seek time	
	5 ms track-to-track
	16 ms average
	35 ms maximum
Average latency	8.3 ms
Interface	SCSI

Table A-44. RZ24 SCSI Hard Disk Drive Operating Conditions

Temperature range ¹	10°C to 55°C (50°F to 131°F)
Temperature change rate per hour, maximum)	11°C (20°F)
Relative humidity	8% to 80% noncondensing
Maximum wet-bulb temperature	26°C (78°F)
Minimum dew-point temperature	2°C (36°F)
Altitude	-300 to 4600 m (-1000 to 15,000 ft)

¹Reduce maximum temperature by 1.8°C for each 1,000 meter (1.0°F for each 1,000 ft) increase in altitude.

Table A-45. RZ24 SCSI Hard Disk Drive Nonoperating Conditions

Temperature range	-40°C to 66°C (-40°F to 151°F)
Temperature change rate per hour, maximum)	20°C (36°F)
Relative humidity	8% to 95% packaged, noncondensing
Maximum wet-bulb temperature	46°C (115°F) packaged
Altitude	-300 m to 12,200 m (-1,000 ft to 40,000 ft)

RX23 Diskette Drive Equipment Specifications

Table A-46. RX23 Diskette Drive Description

Internal drive	
- Weight	0.48 kg (1.06 lb)
- Height	3.00 cm (1.18 in)
- Width	10.16 cm (4.00 in)
- Depth	15.01 cm (5.91 in)
Number of tracks	80
Number of heads	2
Step rate	3 ms per track
Diskette size	8.9 cm (3.5 in)
Recording surfaces per diskette	2
Sectors per track	9 double density 18 high density
Capacity	
- Bytes per drive	737 KB double density 1,474 KB high density
- Blocks per drive	1,440 double density 2,880 high density
- Block size	512 bytes
Data transfer rate	
- To and from media	250 Kbits per second double density 500 Kbits per second high density
Operating power	3.0 watts
Standby power	0.3 watts

Table A-47. RX23 Diskette Drive Operating Conditions

Temperature range ¹	5°C to 50°C (40°F to 122°F)
Temperature change rate	11°C (20°F) per hour, maximum
Relative humidity	8% to 80%, noncondensing
Maximum wet-bulb temperature	29°C (80°F)
Minimum dew-point temperature	2°C (36°F)
Altitude	-300 to 3060 m (-1,000 ft to 10,000 ft)

¹Reduce maximum temperature by 1.8°C for each 1,000 meter (1.0°F for each 1,000 ft) increase in altitude.

Table A-48. RX23 Diskette Drive Nonoperating Conditions

Temperature	-40°C to 66°C (-40°F to 151°F)
Temperature change rate	20°C (36°F) per hour, maximum
Relative humidity	5% to 95%, packaged
Maximum wet-bulb temperature	46°C (115°F), packaged
Altitude	-300 to 12,300 m (-1,000 ft to 40,000 ft)

Part Numbers

Tables B-1 through B-7 in this appendix contain the part numbers for the DECstation 2100/3100 loopback connectors/plugs/test media, major FRUs, basic components, cords/cables and connectors, and related documentation.

Item numbers in Table B-2 correspond to item numbers shown in Figure B-1.

Table B-1. Loopback Connectors/Plugs/Test Media

Item	Part Number
Internal SCSI loopback connector	12-31188-01
MMJ loopback connector	12-25083-01
Mouse loopback plug	12-25628-01
ThickWire loopback	12-22196-01
ThinWire T-connector	12-25869-01
ThinWire terminators	12-26318-01
RRD40 test disc	30-23507-03
Blank HD floppy diskettes	30-30083-01
Floppy diskette labels	36-30069-01

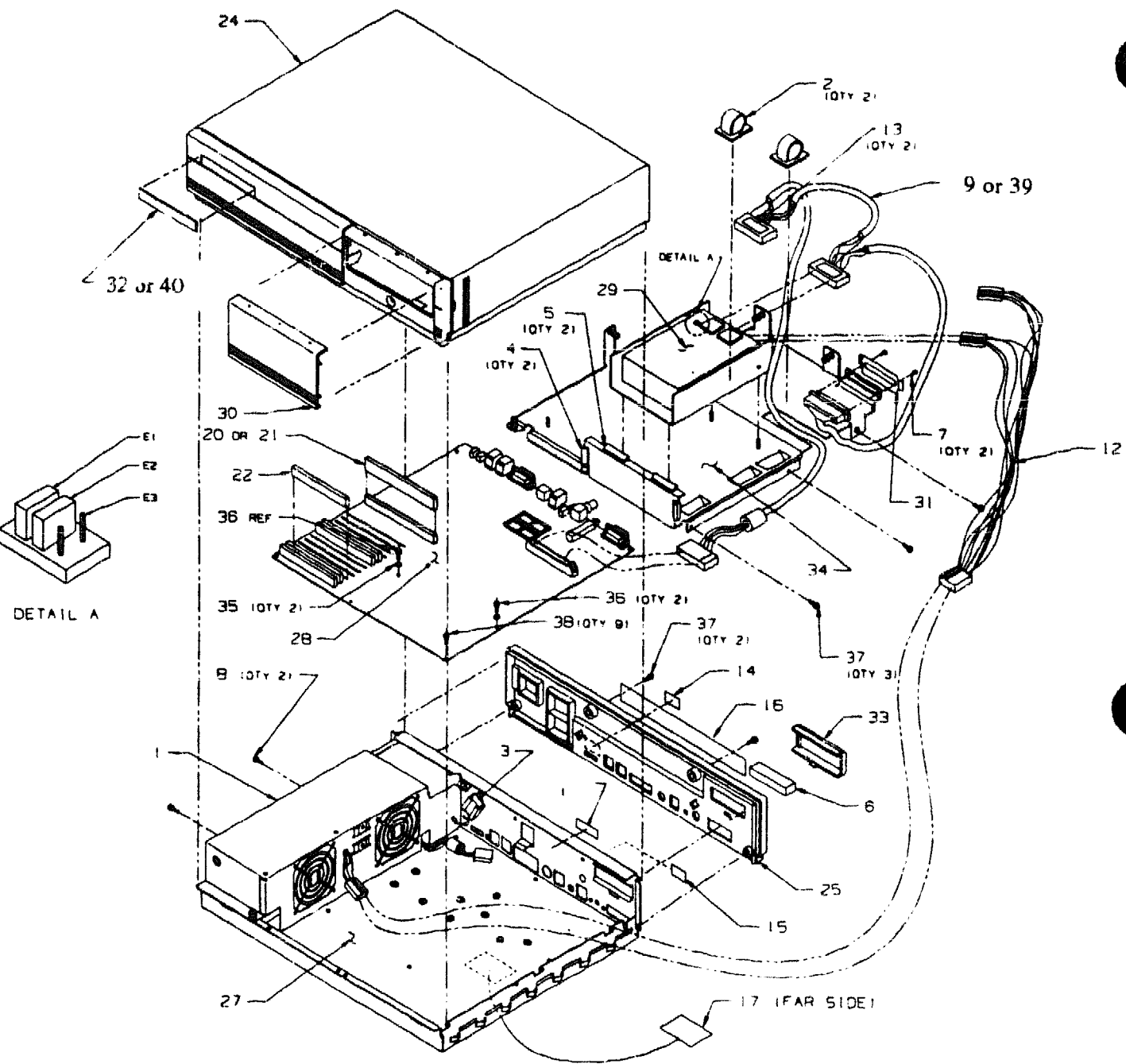

Figure B-1. DECstation 2100/3100 Unit Assembly

Table B-2. Major FRUs

Item Number	Description	Part Number
1	Power supply assembly	H7821-00
3	Battery pack	12-19245-01
9	SCSI internal cable (DECstation 2100/3100 only - non-floppy drive)	17-02358-01
	SCSI internal cable (DECstation 2100/3100 only - floppy drive)	17-02544-01
39	SCSI internal cable (DECstation 3100S only)	17-02358-02
12	SCSI power cable - non-floppy drive	17-02225-01
12	SCSI power cable - floppy drive	17-02440-01
20 or 21	Monochrome Video SIM module	54-19467-01
	Color Video SIM module	54-19469-01
22	Hybrid memory 2Mb	57-30735-02
28	System module (DECstation 3100, 3100S only)	54-19463-01
	System module (DECstation 2100 only)	54-19463-02
29	RZ23 internal disk	RZ23-E
	or RZ24 internal disk	RZ24-E
29 sub	RZ23 logic module	29-27240-01
	or RZ24 logic module	54-17445-04
	RX23 internal floppy disk	RX23-AA
sub	RX23 logic module	54-19288-01
	Disk drive mounting panel - non-floppy drive	74-38401-01
	Disk drive mounting panel - floppy drive	70-27067-01
	Bezel, system unit cover - floppy drive	74-37499-01

Table B-3. Basic Components

Item	Order Number
15-inch monochrome monitor, 120 volts	VR150-AA
15-inch monochrome monitor, 240 volts	VR150-A3
15-inch color monitor, 120 volts	VR160-DA
15-inch color monitor, 240 volts, Northern Hemisphere	VR160-D3
15-inch color monitor, 240 volts, Southern Hemisphere	VR160-D4
16-inch color monitor, 120 volts	VR297-DA
16-inch color monitor, 240 volts, Northern Hemisphere	VR297-D3
16-inch color monitor, 240 volts, Southern Hemisphere	VR297-D4
19-inch monochrome monitor, 120 volts	VR262-AA
19-inch monochrome monitor, 240 volts	VR262-A3
19-inch color monitor, 120 volts	VR299-DA
19-inch color monitor, 240 volts, Northern Hemisphere	VR299-D3
19-inch color monitor, 240 volts, Southern Hemisphere	VR299-D4
External disk drive, 332 Mbytes, 120 volts	RZ55-FA
External disk drive, 332 Mbytes, 240 volts	RZ55-F3
Optical compact disc drive, 600 Mbytes, 120 volts	RRD40-FA
Optical compact disc drive, 600 Mbytes, 240 volts	RRD40-F3
Internal disk drive, 104 Mbytes	RZ23-FF
Internal disk drive, 121 Mbytes	RZ23L-FF
Internal disk drive, 209 Mbytes	RZ24-FF
Internal floppy disk drive, (floppy panel)	RX23-EH
Memory expansion	MS01-AA
Monochrome video SIM module	VFB01
Color video SIM module	VFB02
Tape drive, 95 Mbytes, 120 volts	TK50Z-GA
Tape drive, 95 Mbytes, 240 volts	TK50Z-G3
Tape drive, 2.2 Gbytes, 120 volts	TKZ08-AA
Tape drive, 2.2 Gbytes, 240 volts	TKZ08-A3
Cassette tape drive, 1.2 Gbytes, 120 volts	TLZ04-DA
Mouse	VSXXX-AA

Table B-4. BA42 Storage Expansion Box Configuration

Expansion Box Configuration	Order Number	
	120 Volt	240 Volt
Single RZ55	SZ12A-XA	SZ12A-XB
Double RZ55	SZ12A-AA	SZ12A-AB
Single RZ56	SZ12B-XA	SZ12B-XB
Double RZ56	SZ12B-BA	SZ12B-BB
Single RZ57	SZ12C-XA	SZ12C-XB
Double RZ57	SZ12C-CA	SZ12C-CB
Single RZ55, single RX23	SZ12A-LA	SZ12A-LB
Single RZ55, single RX33	SZ12A-MA	SZ12A-MB
Single RZ55, single TZ30	SZ12A-HA	SZ12A-HB
Single RZ55, single TZK10	SZ12A-EA	SZ12A-EB
Single RZ56, single TZ30	SZ12B-HA	SZ12B-HB
Single RZ56, single TZK10	SZ12B-EA	SZ12B-EB
Single RZ57, single TZK10	SZ12C-EA	SZ12C-EB
Single RX23	SZ12X-LA	SZ12X-LB
Single RX33	SZ12X-MA	SZ12X-MB
Single TZ30	SZ12X-HA	SZ12X-HB
Single TZK10	SZ12X-EA	SZ12X-EB

Table B-5. Cords, Cables, and Connectors

Item	Part Number	Order Number
Expansion box power cord	17-00606-10	—
Monitor-system unit cable (US)	17-00442-26	—
Power supply to internal disks cable	17-02225-01	—
SCSI cover	74-38189-01	—
SCSI 68-pin terminator	12-29635-01	—
SCSI internal cable (DECstation 2100/3100 only)	17-02358-01	
SCSI internal cable (DECstation 3100S only)	17-02358-02	
Serial line cable	—	BC16E-10
System unit power cord (U.S.)	17-00606-10	—
ThickWire cable	—	BNE4C-02
ThickWire loopback connector	12-22196-01	—
ThinWire T-connector	12-25534-01	H8223
ThinWire terminator	12-25535-01	H8225
ThinWire cable (12 ft)	17-01241-09	BC16M-12
ThinWire LAN assembly kit	22-00112-01	BC16T-12
Video cable, monochrome	17-01993-01	BC23K-03
Video cable, color	17-01992-01	BC23J-03
68-pin to 50-pin system unit-expansion box SCSI cable	17-02008-01	BC56H-03 Rev. B01
18-inch 50-pin to 50-pin SCSI cable	—	BC19J-1E
50-pin SCSI terminator for expansion box	12-30552-01	—
25-pin (F) to 6-pin (F) MMJ adapter	12-23599-01	H8571-A
or	—	H8571-F

Table B-6. Software Documentation

Item	Order Number
ULTRIX Media and Doc-TK50	QA-VV1AA-H5
<i>Technical Summary for RISC Processors</i>	AA-MM35A-TE
<i>Documentation Overview for RISC Processors</i>	AA-MM05A-TE
<i>Start-up Instructions for Factory-Installed Software on DECstations 2100/3100</i>	EK-INFIS-IS
<i>Guide to SCAMP for Workstations</i>	EK-SCAMP-UG

Table B-7. Hardware Documentation

Item	Order Number
DECstation 2100/3100 User Documentation Kit	EK-308AB-DK
<i>DECstation 2100/3100 Maintenance Guide</i>	EK-291AB-MG
<i>DECstation 2100/3100 Hardware Installation Guide</i>	EK-290AB-IN
<i>DECstation 2100/3100 Operator's Guide</i>	EK-302AB-OG
Components and Add-Ons	
<i>The RZ22/23 Disk Drive Service Manual</i>	EK-RZ223-SV
<i>The RX23 Diskette Drive Subsystem Service Manual</i>	EK-RX23D-SV
<i>The RZ55 Disk Drive Service Manual</i>	EK-RZ55D-SV
<i>The RZ56 Disk Drive Subsystem Service Manual</i>	EK-RZ56D-SV
<i>The RZ57 Disk Drive Subsystem Service Manual</i>	EK-RZ57D-SV
<i>The TZK10 Cartridge Tape Drive Owner's Guide</i>	EK-TZK10-OG
<i>Installing and Using the LN03</i>	EK-0LN03-UG
<i>LN03 PLUS User Guide</i>	EK-LN03S-UG
<i>ScriptPrinter Installation Guide</i>	EK-LN03R-UG
<i>ScriptPrinter Operator Guide</i>	EK-LN03R-OG
<i>LA100 Letterwriter User Documentation Kit</i>	EK-LW100-UG
<i>Installing and Using the LA75 Companion Printer</i>	EK-0LA75-UG
<i>Installing and Using the LJ250/252 Companion Color Printer</i>	EK-LJ250-DK
<i>TK50Z Tape Drive Subsystem Owner's Manual</i>	EK-LEP05-OM
<i>TK50Z User's Guide</i>	EK-OTK50-UG
<i>TLZ04 Cassette Tape Drive Owner's Manual</i>	EK-TLZ04-OM
<i>BA42 Storage Expansion Box Installation Guide</i>	EK-BA42A-IN

R2000 CPU Registers

This appendix contains information about the register data displayed by the workstation when exception errors occur.

System Control Coprocessor Registers

Registers within the system control coprocessor provide the path through which the virtual memory system's page mapping is examined and changed, and through which the operation modes (kernel versus user mode, interrupts enabled or disabled, cache enabled or isolated, caches normal or switched) may be controlled and by which exceptions may be identified and handled. This section describes each of these registers.

Table C-1 shows the numbering of the system control coprocessor registers.

Table C-1. System Control Coprocessor Numbering

Number	Mnemonic	Description
0	Index	Programmable pointer into the TLB array (on-chip TLB only)
1	Random	Pseudo-random pointer into TLB array (read only, on-chip TLB only)
2	EntryLo	Low half of TLB entry (on-chip TLB only)
4	Context	Pointer to kernel virtual PTE table (on-chip TLB only)
8	BadVAddr	Bad virtual address (read only)
10	EntryHi	High half of TLB entry (on-chip TLB only)
12	SR	Status Register
13	Cause	Cause of last exception
14	EPC	Exception Program Counter
16-31		unused

EntryHi and EntryLo Registers

The EntryHi and EntryLo registers provide a data pathway through which the TLB is read, written, or probed. These registers are loaded with relevant information when translation exceptions occur. These registers are only present for implementations with an on-chip TLB.

EntryHi Register

The EntryHi register is a 32-bit read/write register that is used to access an on-chip TLB. When virtual addresses are presented for translation, the 6 bits of the EntryHi register contain the Process Identifier (PID) used to match the virtual address with a TLB entry.

The EntryHi register also holds the contents of the high-order 32 bits of a TLB entry when performing TLB read and write operations. When a UTLB miss, TLB miss, or TLB modified exception occurs, the EntryHi register is loaded with the Virtual Page Number and the PID of the virtual address that failed to have a matching TLB entry.

The EntryHi register has the following format:

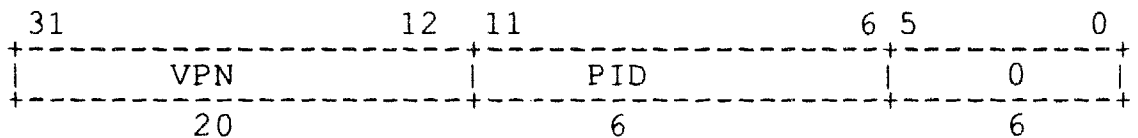

- VPN is the Virtual Page Number (upper bits of virtual address).
- PID is the Process Identifier.
- 0 is unused (ignored on write, zero when read).

EntryLo Register

The EntryLo register is a 32-bit read/write register that is used to access an on-chip TLB. The EntryLo register holds the contents of the low-order 32 bits of a TLB entry when performing TLB read and write operations. The EntryLo register has the following format:

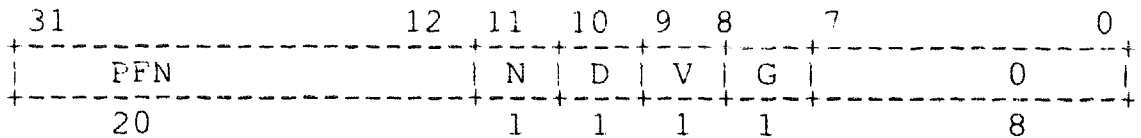

- PFN is the Page Frame Number (upper bits of physical address).
- N, if set, indicates the page is noncacheable.
- D, if set, indicates the page is dirty and writeable.
- V, if set, indicates the entry is valid.
- G, if set, indicates that the PID is ignored.
- 0 is unused (ignored on write, zero when read).

Index and Random Registers

The Index and Random registers are used to access particular entries in the TLB for reading or writing. The Index register also identifies the matching entry when the TLB is associatively probed. These registers are only present for implementations with an on-chip TLB.

TLB Index Register

The TLB Index register is a 32-bit read/write register of which six bits indexes an entry in an on-chip TLB. The high-order bit of the register indicates the success or failure of a TLB probe operation.

The TLB Index register is used to specify the entry in the TLB affected by the TLB ReadI and WriteI instructions. The TLB Index register has the following format:

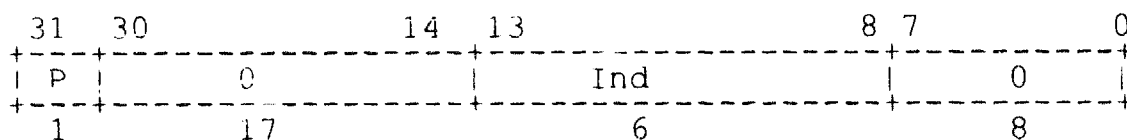

- P is set if the last Probe operation is unsuccessful.
- Ind is the TLB Index.
- 0 is unused (ignored on write, zero when read).

TLB Random Register

The TLB Random register is a 32-bit read-only register of which six bits indexes an entry in an on-chip TLB. The value of this register decrements on each clock cycle of the machine, whether the processor executes an instruction on the clock cycle. The values range between a lower bound set by the number of TLB entries reserved for exclusive use by the operating systems (TLBWIREDD) and an upper bound set by the total number of TLB entries (TLBENTRIES). In the current implementation, the lower bound is 8 and the upper bound is 63.

The TLB Random register is used to specify the entry in the TLB affected by the TLBWRITER instruction. It does not need to be read for this purpose; however, the register is readable in order to verify proper operation of the processor. To simplify testing, this register is set to the upper bound upon system reset. The TLB Random register has the following format:

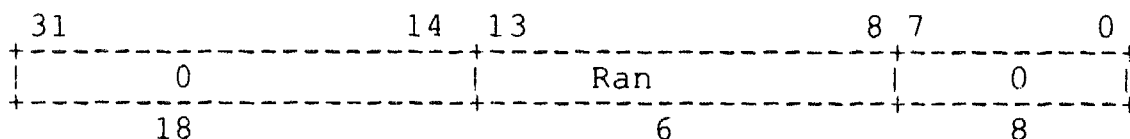

- Ran is the TLB Random Index.
- 0 is unused (zero when read).

Bad Virtual Address and Context Registers

The Bad Virtual Address and Context registers are loaded with the virtual address for which a translation exception occurs. The Context register is specifically used within a fast, minimal TLB exception handler (called the UTLB miss handler) for rapid access of Page Table Entries (PTEs) from main memory. The Context register are only present for implementations with an on-chip TLB.

Bad Virtual Address Register

The Bad Virtual Address register is a 32-bit read only register that displays the most recently translated virtual address that failed to have a valid translation. The Bad Virtual Address register has the following format:

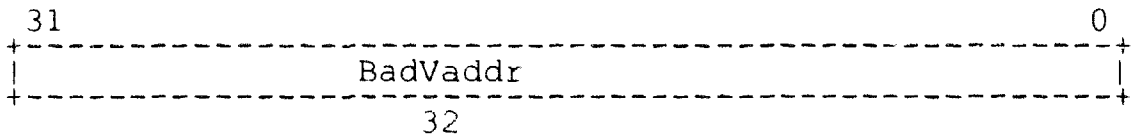

- BadVAddr is the bad virtual address.

Context Register

The Context register is a 32-bit read/write register containing a pointer into a kernel virtual PTE array. It is designed for use in the UTLB miss handler, which loads TLB entries for normal user-mode references.

The 19-bit BadVPN field in the register is not writeable. It contains bits 30..12 (user-segment virtual page number) of the BadVaddr register. Bit 31 is excluded because the UTLB miss handler is only invoked on user-segment references. Normally, it contains the VPN of the most recently translated virtual address that did not have a valid translation.

The 11-bit PTEBase field is writeable and readable. It indicates the base address of the PTE table of the currently executing user process. The Context register has the following format:

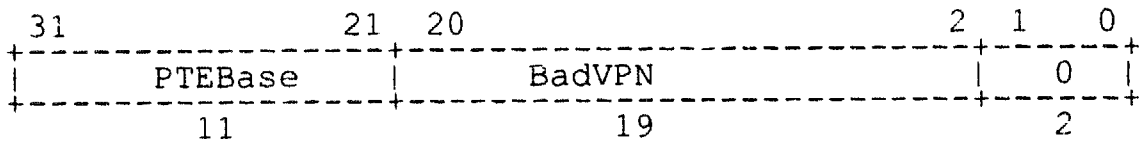

- PTEBase is the base address of the PTE.
- BadVPN is the VPN of the failed virtual address.
- 0 is unused (ignored on write, zero when read).

- CU control the usability of each of the four coprocessor unit numbers (1 = usable, 0 = unusable). Coprocessor zero is always usable when in kernel mode, regardless of the setting of the CU_0 bit.
- DS is an implementation-dependent diagnostic status field.
- IM is the Interrupt Mask. It controls the enabling of each of the external, internal, coprocessor, and software interrupts (0 = disabled, 1 = enabled).
- KU_0 is the old kernel/user mode (0 = kernel, 1 = user).
- IE_0 is the old interrupt enable (0 = disable, 1 = enable).
- KU_p is the previous kernel/user mode (0 = kernel, 1 = user).
- IE_p is the previous interrupt enable (0 = disable, 1 = enable).
- KU_c is the current kernel/user mode (0 = kernel, 1 = user).
- IE_c is the current interrupt enable (0 = disable, 1 = enable).
- 0 is unused (ignored on write, zero when read).

Diagnostic Status

The diagnostic facilities are heavily dependent on the characteristics of the cache and virtual memory system on the implementation, therefore, the layout of the diagnostic status field is implementation-dependent. Its normal use is for diagnostic code, and in certain cases, for use by the operating system diagnostic facilities (such a reporting parity errors), and on some machines, for relatively rare operations such as flushing caches. In normal operation, this field should be set to zero by operation system code.

The diagnostic status bits: BEV, TS, PE, CM PZ, SwC, and IsC provide a completed fault detection capability, but are not intended to provide for extensive fault diagnosis.

The SwC bit controls the switching of control signals for instructions and data caches associated with the processor. When the bit is changed, cache control signals are altered so that instruction and data caches are effectively interchanged. The processor must be executing from an uncached region and must not be executing loads or stores near the time of cache switching.

The IsC bit, when set, causes the cache currently being used as the data cache to be effectively isolated from the rest of the memory system, making cache diagnostics possible (The selection of the data cache is dependent on the state of the SwC bit). When the IsC bit is set, store operations affect only the cache (main memory writes are inhibited), and load operations return the data at the addressed location in the cache, whether a cache miss occurs (main memory reads are inhibited). Uncached data references are not generally useful with IsC set, but their handling is as follows: uncached store operations affect neither the cache nor the main memory system, and uncached load operations return the data at the addressed location in the cache. IsC affects only data reference; instruction fetches are not affected. This bit may also be used by operating system code to flush caches without causing associated main memory accesses.

The PZ bit, when set, causes zero to replace the normal outgoing parity bits which are generated on a store instruction, covering both cache data and tags. This permits the writing of incorrect parity bits in the caches, checking each parity tree individually within the cache diagnostics.

The CM bit, when the cache is isolated, indicates whether or not the most recent data cache load resulted in a cache miss. This bit is used by cache test programs to verify the proper functioning of the cache tag and parity bits.

The PE bit indicates whether a cache parity error occurred. It is set on a cache parity error and reset by writing a one to this bit. Writing a zero to this bit does not affect its value. This bit is used to log cache parity errors in software, as otherwise, they are recovered from completely transparently. Within cache diagnostics, this bit is used to verify proper functioning of the cache parity bits and of the cache parity trees.

The TS bit is read only and indicates that the TLB has shut down due to attempts to cause several entries in the TLB to be accessed simultaneously. This mechanism protects the TLB from hardware failures in the event of catastrophic software misuse of the TLB. When the TLB is in this state, all translations and PROBE accesses are inhibited, and have

undefined effects. This state can be cleared only by asserting RESET.

The Bootstrap Exception Vectors (BEV) bit, when set, causes the UTLB miss exception vector to be relocated to a virtual address of 0xbfc00100 and the general exception vector to 0x80000080 (general), respectively. This bit is used when diagnostic tests cause exceptions to occur prior to verifying proper operation of the cache and main memory system.

The format of the diagnostic status field is:

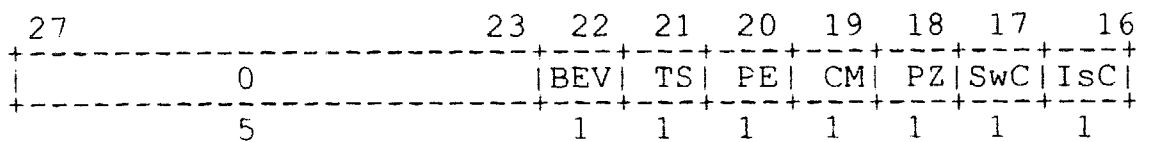

- BEV controls the location of UTLB miss and general exception vectors (0 = normal, 1 = bootstrap).
- TS indicates that TLB shut-down occurred.
- PE indicates that a cache parity error occurred. This bit may be cleared by writing a one to this bit position.
- CM indicates whether a data cache miss occurred while in cache test mode (0 = hit, 1 = miss).
- PZ controls the zeroing of cache parity bits (0 = normal, 1 = parity forced to zero).
- SwC controls the switching of the data and instruction caches (0 = normal, 1 = switched).
- IsC controls isolation of cache (0 = normal, 1 = cache isolated).
- 0 is unused (ignored on write, zero when read).

Cause Register

The Cause register is a 32-bit read/write register that describes the nature of the last exception. a 4-bit exception code indicates the cause of the exception and the remaining fields contain detail information relevant to the handling of certain types of exceptions.

Table C-2. Exception Codes

Number	Mnemonic	Description
0	Int	Interrupt
1	Mod	TLB modification exception
2	TLBL	TLB miss exception (load or instruction fetch)
3	TLBS	TLB miss exception (store)
4	AdEL	Address error exception (load or instruction fetch)
5	AdES	Address error exception (store)
6	IBE	Bus error exception (instruction fetch)
7	DBE	Bus error exception (data reference: load or store)
8	Sys	Syscall exception
9	Bp	Breakpoint exception
10	RI	Reserved instruction exception
11	CpU	Coprocessor Unusable exception
12	OV	Arithmetic Overflow exception
13-31		reserved

Exception Program Counter (EPC)

The EPC register indicates the virtual address at which the most recent exception occurred. This register is a 32-bit read only register that contains an address at which instruction processing may resume after servicing an exception. For synchronous exceptions, the EPC register contains the virtual address of the instruction which was the direct cause of the exception. When that instruction is in a branch delay slot, the EPC register contains the virtual address of the immediately preceding branch or jump instruction.

If the exception is caused by recoverable, temporary conditions (such as a TLB miss), the EPC register contains a virtual address at the instruction which caused the exception. Thus, after correcting the conditions, the EPC registers contains a point at which execution can be legitimately resumed. The EPC register has the following format:

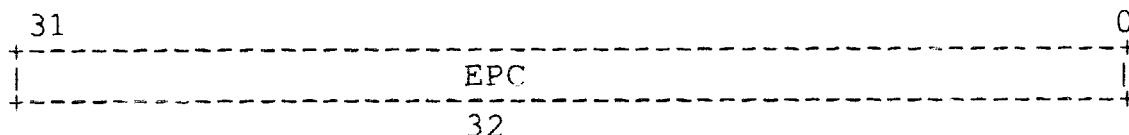

- EPC is the Exception Program Counter.

Status and Error Code Descriptions

This appendix lists status and error codes in the sequence shown in Table D-1.

Table D-1. Status and Error Code Locator

Section	Type	Code Range		Location
Console	Status	-425-00	-47d-00	Table D-2
Console	Error	?401-00	?47b-00	Table D-3
Diagnostics	Status	-001-00	-05f-00	Table D-4
Diagnostics	Error	?06b-00	?0d4-01	Table D-5
SCSI/SII	Status	-047-01	-04c-02	Table D-6
SCSI/SII	Error	?0bd-01	?0d3-22	Table D-7

Table D-2. Console and Boot Status Codes

Status Code	Description/FRU or Error Type
-425	Server name
-42c	Numeric conversion overflow
-42e	MOP packets from wrong server rejected
-42f	MOP server
-434	MOP target name
-435	MOP memory address for last packet loaded
-436	MOP target address
-437	MOP host name
-438	MOP host address
-439	MOP host time
-43d	Entry point of downloaded code
-45c	Initializing the time of day clock
-471	Auto boot in progress
-473	Restart in progress
-479	List of devices
-47c	Transfer address for loaded file
-47d	Attempt to overwrite stack or bss

Console and boot error codes are listed in Table D-3. FRU or Error Type column abbreviations are defined below.

- CE - Command Error (operator error)
- PE - Programming Error
- IE - Internal Error (in the ROM code)
- NE - Network Error
- HE - Hardware Error

Table D-3. Console and Boot Error Codes

Error Code	Description	FRU or Error Type
?401	When the console attempted to open the console for input it failed.	IE
?402	When the console attempted to open the console for output it failed.	IE
?403	There are no more I/O buffers to process a request. This normally indicates that some code has "lost" a buffer and never returned it to the pool after using it.	IE
?404	An attempt was made to return a buffer that was marked as still in use.	IE
?405	A device was opened that specified a file structure type unknown by the I/O code.	IE
?406	A device was opened that specified a file structure type unsupported by this release of the I/O code.	IE
?407	A filename was specified with a device which is not file structured, i.e., a filename with a device such as tty().	CE
?408	The I/O block passed to an I/O routine was invalid or possibly a null pointer was passed.	IE
?409	This type of lseek is not supported.	PE
?40a	The type of lseek specified is unknown.	PE
?40b	Offsets (set by lseek) must be a multiple of the block size (512).	PE
?40c	Too many devices are open at once.	PE

(continued on next page)

Table D-3 (Cont.). Console and Boot Error Codes

Error Code	Description	FRU or Error Type
?40d	An unknown device was specified.	CE, PE
?40e	An invalid path or file name was specified.	CE, PE
?40f	A character was lost on input.	IE
?410	A device driver received an unsupported request.	IE
?411	Argument size to badaddr invalid.	IE
?412	Argument size to wbadaddr invalid.	IE
?413	ARP couldn't resolve network address.	NE
?414	Exhausted pool of mbufs.	IE
?415	ARP target is local host.	IE
?416	An IP packet was received from the network that had the same IP address as ourselves. The Ethernet address of the sender is displayed.	NE
?417	The bootblock of a device specified to boot does not have valid magic number.	CE
?418	A read error was detected.	HE
?419	An open failed, either because the device does not exist or some parameter to the open was in error.	CE, PE
?41a	Bootp consistency check of Ethernet info block size in job failed.	IE
?41b	Bootp consistence check of Ethernet info block filename size failed.	IE
?41c	Controller number is out of range for the device.	CE, PE
?41d	Filename is too long.	CE, PE
?41e	Host name is too long for bootp.	CE, NE
?41f	IP address in \$inetaddr is bad or not set. It is normally set automatically but may be set by the operator.	IE, CE
?420	Bootp was unable to set the se interface address.	IE

(continued on next page)

Table D-3 (Cont.). Console and Boot Error Codes

Error Code	Description	FRU or Error Type
?421	IP address in \$sinetaddr is bad. It is normally set automatically but it may be set by the operator.	IE, CE
?422	IP address in \$ginetaddr is bad. It is normally set automatically but it may be set by the operator.	IE, CE
?423	IP address of workstation is bad. **** Never used. ****	IE
?424	Bootp bind to se driver failed.	IE
?426	File not found by server.	NE
?427	Backward seek error, reverse seeks are not supported.	PE
?428	tftp bind failed.	IE
?429	The tftp server detected an error, the error code and error string is displayed.	NE
?42a	An I/O function was attempted that was not supported for the target device.	IE
?42b	An invalid baud rate specified for baud2 or baud3. The environment variable and the value are displayed.	CE
?42d	MOP bind failed.	IE
?430	No MOP port socket was found.	IE
?431	Socket append error.	IE
?432	Improper Ethernet address.	IE
?433	A MOP packet arrived out of sequence.	NE
?43a	MOP packet code error. A MOP packet with an invalid packet type code was received.	NE
?43b	Write error.	HE
?43c	Timeout, typically a server started a transfer and then quit prematurely.	NE
?43e	Unrecognized command.	CE
?43f	An undefined environment variable was referenced.	IE
?440	Line entered was too long.	CE

(continued on next page)

Table D-3 (Cont.). Console and Boot Error Codes

Error Code	Description	FRU or Error Type
?441	Quotes not balanced.	CE
?442	Device must be a character device to enable it.	CE
?443	Device is already enabled, you can't enable it again.	CE
?444	Too many console devices, an attempt was made to enable more console devices than are supported.	CE
?445	Device is not enabled, you can't disable it again.	CE
?446	SCSI bus reset failure.	HE
?447	Unit error, the unit does not exist for the device.	CE, PE
?448	Partition error, the partition does not exist for the device.	CE, PE
?449	SCSI device setup failure.	HE
?44a	Device must be a direct access device. A SCSI device was accessed as rz(x) where device x is not a direct access device.	CE, PE
?44b	A partition was specified for an unpartitioned device.	CE, PE
?44c	Attempt to read beyond end of partition.	PE
?44d	Buffer too large or not multiple of the sector size.	PE
?44e	se already bound.	IE
?44f	No sockets available.	IE
?450	No binding for socket.	IE
?451	Socket data consistency error.	IE
?452	Datagram is too large.	IE
?453	se initialization error.	HE
?454	Network address family not supported.	PE, IE
?455	se buffer too small for data, segmentation is not supported.	PE, IE
?456	se received bad packet.	HE, NE

(continued on next page)

Table D-3 (Cont.). Console and Boot Error Codes

Error Code	Description	FRU or Error Type
?457	Too many strings have been defined. This generally occurs if too many environment variables have been defined.	CE, PE
?458	String space exhausted. This generally occurs if too many environment variables have been defined or if some names or values are very long.	CE, PE
?459	String not found.	PE
?45a	Battery backup to non-volatile ram lost.	HE
?45b	Cannot set the time of day clock.	HE
?45d	An attempt was made to access a SCSI device through the tz() driver and the device was not a sequential device.	CE
?45e	Rewind error.	HE
?45f	Tape drive must support variable unbuffered mode.	HE
?460	Error in writing filemark.	HE
?461	Error in backspace.	HE
?462	IP header length error.	NE
?463	IP checksum error.	NE
?464	IP length error.	NE
?465	IP packet length error.	NE
?466	IP Options error.	NE
?467	IP fragments error.	NE
?468	IP packet is too large.	NE
?469	UDP header length error.	NE
?46a	UDP packet length error.	NE
?46b	UDP checksum error.	NE
?46c	No UDP port socket found.	IE
?46d	Ran out of data computing checksum.	NE
?46e	Option not valid for this command.	CE
?46f	\$bootpath not set when either a boot or auto command is issued.	CE

(continued on next page)

Table D-3 (Cont.). Console and Boot Error Codes

Error Code	Description	FRU or Error Type
?470	Couldn't boot indicated file either because it didn't exist or because of a hardware error.	CE, HE
?472	Restart failed, most likely because no restart block has been established by the operating system.	PE
?474	get_memory size error.	IE
?475	PROM error in indicated routine.	IE
?476	Boot file is not in a.out format. A tftp boot request specified a boot file that is not in the proper format.	NE, CE
?477	File is in wrong byte order. A tftp boot request specified a boot file in big endian order.	NE, CE
?478	Magic number is wrong in boot file loaded via tftp.	NE
?47a	An otherwise unrecognized command was entered and no path environment variable was found informing the console from where (what device) to find the command code. This message will always be followed by an "ill cmd" message.	CE
?47b	Nonvolatile ram corrupted, usually power was lost.	HE

Table D-4. Diagnostic Status Codes

Status Code	Description/FRU or Error Type
-001-00	Data cache - data
-002-00	Instruction cache - data
-003-00	Data cache - segment test
-004-00	Instruction cache - functionality
-005-00	Instruction cache - tag
-005-01	Data cache - tag
-005-02	Instruction cache - tag parity
-005-03	Data cache - tag parity
-005-04	Instruction cache - data parity
-005-05	Data cache - data parity
-005-06	Instruction cache - valid bit
-005-07	Data cache - valid bit
-009-00	vdac color map write/read
-00a-00	vdac overlay register write/read
-00b-00	vdac color map write read
-00c-00	vdac color map write read
-00d-00	vdac overlay register write/read
-00e-00	vdac overlay register write/read
-00f-00	vdac output compare
-010-00	non-volatile RAM write/read
-011-00	non-volatile ram write/read
-012-00	non-volatile ram write/read
-013-00	real time clock register write/read
-014-00	real time clock set/read time
-015-00	real time clock periodic interrupt
-017-00	floating point unit
-01c-00	dz all line transmit/receive
-01d-00	dz single line transmit/receive full silo
-01e-00	dz single line transmit/receive silo overflow
-01f-00	dz multiple line transmit/receive mixed silo

(continued on next page)

Table D-4 (Cont.). Diagnostic Status Codes

Status Code	Description/FRU or Error Type
-020-00	dz silo alarm/dz interrupt
-021-00	dz modem control
-022-00	lance buffer write/read
-023-00	lance buffer write/read
-024-00	lance buffer write/read
-025-00	lance buffer write/read
-026-00	lance buffer write/read
-02a-00	SII buffer write/read
-02b-00	SII buffer write/read
-02c-00	SII buffer write/read
-02d-00	SII buffer write/read
-02e-00	SII buffer write/read
-02f-00	video memory write/read
-030-00	video memory write/read
-035-00	main memory write/read
-036-00	main memory write/read
-037-00	main memory write/read
-038-00	main memory odd/even parity check
-039-00	status message listing memory size to be tested
-03c-00	pcc set cursor plane a
-03d-00	pcc set cursor plane b
-03e-00	pcc set area detect 1
-03f-00	pcc set area detect 2
-040-00	pcc enable cursor plane a
-041-00	pcc enable cursor plane b
-042-00	pcc enable area detect 1
-043-00	pcc enable area detect 2
-04f-00	lance csr
-050-00	lance internal loopback
-051-00	lance external loopback

(continued on next page)

Table D-4 (Cont.). Diagnostic Status Codes

Status Code	Description/FRU or Error Type
-052-00	lance crc error detect
-053-00	lance promiscuous mode
-054-00	lance collision detect
-055-00	lance multicast
-056-00	lance interrupt
-057-00	system board control and status register write/read
-058-00	set led patterns
-059-00	write buffer error address latch
-05a-00	mouse self-test
-05b-00	keyboard self-test
-05c-00	color mask write/read
-05d-00	Ethernet station address ROM read
-05e-00	write/read of tlb registers
-05f-00	tlb probe

Table D-5. Diagnostic Error Codes

Error Code	Description	FRU or Error Type
?06b-00	lance csr - read back	Check the network connection. Make sure the selected Ethernet connection is installed properly, terminated, or connected to a network. Replace the system module.
?06c-00	lance csr - idon bit not set.	
?06c-01	lance csr - strt bit not set.	
?06d-00	lance interrupt not detected on transmit packet.	
?06d-01	lance own bit not set in transmit buffer.	
?06d-02	lance csr tint bit not set.	
?06e-00	lance received packet when in non-promiscuous mode.	
?06e-01	lance did not receive packet when in promiscuous mode.	
?06e-02	lance received packet when multicast was disabled.	
?06e-03	lance did not receive packet when multicast was enabled.	
?06e-04	lance receive buffer own bit not set.	
?06e-05	lance receive interrupt not set.	
?06f-00	lance received packet size mismatch with transmit packet.	
?070-00	lance received data does not match transmitted data.	
?070-01	lance tried and failed to send packet 32 times.	
?072-00	lance crc error on a received packet.	
?076-00	lance did not report a crc error.	
?082-00	write to cache failed to write through to memory.	Replace the system module.
?082-01	"CACHE - exp k0_ret" Write to cached address space failed.	

(continued on next page)

Table D-5 (Cont.). Diagnostic Error Codes

Error Code	Description	FRU or Error Type
?082-01	"CACHE - exp k1_ret" Write to uncached address space failed.	
?083-01	Instruction was loaded into the instruction cache, when checked a cache miss (CM) was detected indicating that the instruction was not cached.	
?083-02	After the CM bit was tested the location was checked to see if it had the correct instruction cached.	
?083-03	Instruction was loaded into the instruction cache at another location, when checked a cache miss (CM) was detected indicating that the instruction was not cached.	
?083-04	After the CM bit was tested the location was checked to see if it had the correct instruction cached.	
?083-05	Instruction was loaded into the instruction cache at another location, when checked a cache miss (CM) was detected indicating that the instruction was not cached.	
?083-06	After the CM bit was tested the location was checked to see if it had the correct instruction cached.	
?083-07	Instruction was loaded into the instruction cache at another location, when checked a cache miss (CM) was detected indicating that the instruction was not cached.	
?083-08	After the CM bit was tested the location was checked to see if it had the correct instruction cached.	
?083-09	Instruction was loaded into the instruction cache but failed to execute.	

(continued on next page)

Table D-5 (Cont.). Diagnostic Error Codes

Error Code	Description	FRU or Error Type
?083-0a	Instruction was loaded into the instruction cache but failed to execute.	
?083-0b	Instruction was loaded into the instruction cache but failed to execute.	
?083-0c	Instruction was loaded into the instruction cache but failed to execute.	
?083-0d	Instruction cache was loaded with a loop, failed to execute at 1 instruction per cycle.	
?084-00	Failed write/read data pattern test of the data portion of a cache entry.	
?084-01	R2000 parity error bit is checked after a write/read of the data portion of a cache entry.	
?084-0a	Instruction cache tag error.	
?084-0b	Data cache tag error.	
?084-0c	Instruction cache tag parity error.	
?084-0d	Data cache tag parity error.	
?084-0e	Instruction cache data parity error.	
?084-0f	Data cache data data parity error.	
?084-10	Instruction valid bit error.	
?084-11	Data valid bit error.	
?08a-00	Video ram failed write/read test.	Replace the Video SIM module. Replace the system module.
?08b-00	Write/read of SCSI buffer.	Replace the system module.
?08c-00	Failed write/read data pattern test of the network buffer.	
?08d-00	Failed write/read of rtc ram.	
?08e-00	No vram installed.	To be supplied.
?08f-00	Mono video is installed, tried to do color video test.	

(continued on next page)

Table D-5 (Cont.). Diagnostic Error Codes

Error Code	Description	FRU or Error Type
?090-00	Color map failed a write/read during data patterns test.	Check the video cable. Replace the Video SIM module. Replace the system module.
?091-00	Overlay registers failed write/read test.	
?092-00	DAC output comparators and csr video compare bits are used to detect output miscompares.	
?092-01	PCC is set up to generate a interrupt, vint bit in the csr is not set.	
?092-02	VINT bit in the csr is not clear.	
?094-00	Real time clock UIP bit did not deassert.	Replace the system module.
?095-00	Write/read of real time clock registers.	
?096-00	Real time clock interrupt did not assert.	
?097-00	Unexpected real time clock interrupt.	
?098-00	Real time clock set/read time.	
?09b-01	Failed write/read of 0's to fpu register 0.	
?09b-02	Failed write/read of 5's to fpu register 1.	
?09b-03	Failed write/read of a's to fpu register 2.	
?09b-04	Failed write/read of f's to fpu register 3.	
?09h-05	Failed sequence of add, subtract and convert instructions.	
?09b-06	Failed sequence of add, subtract and convert instructions.	
?09b-07	Failed sequence of add, subtract, multiply, divide and convert instructions.	

(continued on next page)

Table D-5 (Cont.). Diagnostic Error Codes

Error Code	Description	FRU or Error Type
?09b-08	Failed sequence of subtract, multiply and convert instructions.	
?09b-09	Failed sequence of multiply, divide and convert instructions.	
?09b-0a	Failed sequence of add, subtract, multiply and convert instructions.	
?09b-0b	Failed sequence of add, subtract and convert instructions.	
?09b-0c	Failed clear of the FPU IRQ.	
?09b-0d	Failed to generate exception and assertion of FPU IRQ.	
?0a4-00	If crsrtst bit is set in csr, pcc test bit is clear, crsrtst bit in csr will not clear.	
?0a4-01	PCC test bit is forced to assert, crsrtst bit in csr failed to assert.	
?0a4-02	PCC test bit is forced to assert, crsrtst bit in csr failed to assert.	
?0a4-03	PCC test bit is forced to assert, crsrtst bit in csr failed to assert.	
?0a4-04	PCC test bit is forced to assert, crsrtst bit in csr failed to assert.	
?0a5-00	If crsrtst bit is set in csr, PCC test bit is clear, crsrtst bit in csr will not clear.	
?0a5-01	Cursor plane a is set up and enabled, crsrtst bit in csr failed to assert.	
?0a5-02	Cursor plane b is set up and enabled, crsrtst bit in csr failed to assert.	
?0a5-03	Area detect 1 is set up and enabled, crsrtst bit in csr failed to assert.	
?0a5-04	Area detect 2 is set up and enabled, crsrtst bit in csr failed to assert.	
?0aa-00	No dz interrupt.	Check all connections. Replace the system module

(continued on next page)

Table D-5 (Cont.). Diagnostic Error Codes

Error Code	Description	FRU or Error Type
?0ab-00	DZ modem status register dsr bit set.	
?0ac-00	DZ modem status register dsr bit not clear.	
?0ad-00	DZ csr trdy bit not set.	
?0ae-00	DZ interrupt not set.	
?0ae-01	Unexpected dz interrupt.	
?0ae-02	DZ interrupt not set by silo alarm.	
?0af-00	DZ timeout - clr bit in csr would not clear.	
?0af-01	DZ timeout - csr not correct after a transmit.	
?0af-02	DZ timeout - trdy bit in csr will not set.	
?0af-03	DZ timeout - csr not correct after receive.	
?0b0-00	DZ receive buffer did not receive expected data.	
?0b1-00	DZ CSR not correct after transmit.	
?0b6-00	Failed read of Ethernet station ROM data patterns.	Check that the ESAR chip is seated properly. Replace the system module.
?0b6-01	Failed checksum calculation of Ethernet station ROM.	
?0b7-00	MEMERR bit in the system board csr cannot be cleared.	Replace the system module.
?0b7-01	Valid memerr condition did not assert the csr memerr bit.	
?0b7-02	Invalid memory location is written, write buffer error address latch read failed to return the correct address.	
?0b8-00	Could not clear the CSR.	
?0b8-01	Write/read of txdis bit failed.	
?0b8-02	Generated valid memerror condition, memerr bit failed to set.	

(continued on next page)

Table D-5 (Cont.). Diagnostic Error Codes

Error Code	Description	FRU or Error Type
?0b8-03	Generated valid memerror condition, memerr interrupt failed to assert at R2000.	
?0c8-00	The R2000 translation lookaside buffer failed write/read tests to its 64 entries.	
?0c8-01	The TLB is set with entries then the entryHi registers used to probe for a match.	
?0c9-00	Write/read failure of color mask.	Replace the Video SIM module. Replace the system module.
?0d0-00	Keyboard failed to respond after being sent a self-test command.	Replace the keyboard. Replace the system module.
?0d0-01	Keyboard failed to respond with good status after being sent a self test command.	
?0d1-00	Mouse failed to respond after being sent a self test command.	Replace the mouse. Replace the keyboard.
?0d1-01	Mouse failed to respond with good status after being sent a self test command.	
?0d2-00	Failed write/read of data patterns with parity checking disabled.	Replace the D SIM modules. Replace the system module.
?0d4-00	Failed write/read even data pattern test with parity checking enabled.	
?0d4-01	Failed write/read odd data pattern test with parity checking enabled.	

Table D-6. SCSI/SII Status Codes

Status Code	Description/FRU or Error Type
-047-01	SII buffer address test.
-047-02	begin SII buffer testing.
-047-03	checking SII buffer for pattern xxxx.
-047-04	writing SII buffer with 4 patterns.
-048-01	SII target test-internal loopback mode.
-048-02	Setting stlp reg-a dssi mode pointer.
-048-03	building outbound command and data packet.
-048-04	setting loopback mode in dictrl reg.
-048-05	R2000 driving sel and enabling parity.
-048-06	The SII is SCSI address 7.
-048-07	Establish dssi mode.
-048-08	R2000 is dev 0 and selects dev 7-SII.
-048-09	R2000 deasserts sel bus signal.
-048-0a	R2000 sends a sequence of 6 command bytes.
-048-0b	R2000 sends data bytes.
-048-0c	R2000 checks status sent by SII.
-048-0d	Check buffer status--dssi defines a data packet structure which includes numerous pointer and status bytes.
-048-0e	Check command block.
-048-0f	Check data bytes.
-048-10	Target test passes.
-049-01	SII initiator test--internal loopback.
-049-02	Building outbound packet at address xxxx.
-049-03	Set dssi reg ILP.
-049-04	Set loopback mode in dictrl reg.
-049-05	Driving sel and parity lines.
-049-06	The SII is SCSI address 7.
-049-07	Forcing arbitration win-dev 7 gets bus selects dev 0.
-049-08	Establishing dssi mode.
-049-09	R2000 drives bsy and CD to respond to selection.

(continued on next page)

Table D-6 (Cont.). SCSI/SII Status Codes

Status Code	Description/FRU or Error Type
-049-0a	R2000 receives 6 command bytes.
-049-0b	Target switches to data phase.
-049-0c	R2000 receives data.
-049-0d	Disconnect from target.
-049-0e	Check the status of the buffer to see that the transfer was successful.
-049-0f	Verify that CSTAT register agrees with current state of disconnect.
-049-10	Kill all interrupt sources in CSTAT reg and disable interrupts.
-049-11	Initiator test passes.
-049-12	Switch to status in phase.
-04a-01	SCSI loopback check.
-04a-02	SII external drive loopback tests.
-04a-03	Walk ones around the loop.
-04a-04	External loopback driver enable.
-04a-05	Disable ext drivers.
-04a-06	Rezero sdb/sc1 register.
-04a-07	Data loopback path ok.
-04a-08	Control signal testing.
-04a-09	Enable initiator control signal dvrs.
-04a-0a	Enabling target drivers.
-04a-0b	Enable arbitration drivers.
-04a-0c	External drive tests passed.
-04b-01	Start SCSI device testing.
-04b-015	This test writes on the hard drive. Are you sure you want to do this?
-04b-016	Type in uppercase Y for Yes and N for No.
-04b-02	Starting off-line testing of device U#.
-04b-03	Self-test is not available for this device. The device does not support SEND DIAGNOSTIC.
-04b-04	Off-line self test on unit# passed.
-04b-05	Testing hard drive u#.
-04b-06	Self-test on rz# passes.

(continued on next page)

Table D-6 (Cont.). SCSI/SII Status Codes

Status Code	Description/FRU or Error Type
-04b-07	Testing tape drive at u#.
-04b-08	Testing CD-ROM drive u#.
-04b-09	This test performs writes on the media. Are you sure you want to do this?
-04b-0a	Command aborted.
-04b-0b	Help menu follows.
-04b-0c	Device u# is not ready--off-line.
-04b-0d	Formatting hard drive rz#.
-04b-0e	Attempting to bring device to ready state.
-04b-0f	Format aborted at your request.
-04b-10	Rewinding tape to load point.
-04b-11	One moment please--this takes a while.
-04b-12	Writing tape block #.
-04b-13	A write of n tape blocks has been successfully completed.
-04b-14	Writing file mark to tape.
-04b-1a	Reading block #.
-04b-1b	Canned tape test passes.
-04b-1c	Bring CD-ROM unit on-line.
-04b-1d	Executing extended self-test on unit.
-04b-1e	CD-ROM UNIT passes all tests.
-04b-1f	Executing extended self test on unit u#.
-04b-20	Unit U# passes all tests.
-04b-21	Cumulative error total for this device.
-04b-22	Device status reported as not ready.
-04b-23	Device reports ready status.
-04c-01	Scanning SCSI bus for devices.
-04c-02	No SCSI devices were found in the system.

Table D-7. SCSI/SII Error Codes

Error Code	Description	FRU or Error Type
?0bd-01	The contents of the CSR register was not as expected when read back after a write to that register.	
?0bd-02	The R2000 interrupt register (CAUSE) could not be cleared of a pending interrupt.	
?0bd-03	A status byte other than that expected was read during a status in bus phase. The SII is operating in the target mode.	
?0bd-04	The contents of the recovered data buffer as a result of reading target data do not match those expected. Possible SII buffer memory error.	Run "scsi t1" to confirm buffer error problem. Otherwise SII chip failure is indicated.
?0bd-05	An interrupt was expected from the SII but not detected in the R2000 CAUSE register. The data values indicate actual and expected cause register values.	Likely to be an SII interrupt line failure.
?0bd-06	During initiator mode test the R2000 has received a bad command byte or bytes from the SII.	Probable SII chip failure.
?0bd-07	During initiator mode test the data transferred to the SII by the R2000 was detected in error.	Possible SII memory buffer failure or cpu to SII memory buffer addressing failure.
?0bd-08	The SII memory buffer contents are not as expected on readback.	Possible SII memory buffer failure.
?0bd-09	The SII connection status register (CSTAT) has inappropriate values following detection of a disconnect.	
?0bd-0a	Following completion of the test interrupt bits in the SII cstat register were not cleared.	
?0bd-0b	While setting up the SII to perform external loopback testing, the SC1 register could not be reset to 0x00.	

(continued on next page)

Table D-7 (Cont.). SCSI/SII Error Codes

Error Code	Description	FRU or Error Type
?0bd-0c	While setting up the SII to perform external loopback testing, the SDB register could not be reset to 0x00.	
?0bd-0d	The dictrl reg of the SII could not be set to the expected value.	
?0bd-0e	The SCSI bus drivers could not be properly enabled to permit driving the SCSI bus.	
?0bd-0f	An external loopback fixture was not found when one was expected to be present.	If aaaa = 0x0000 then it is likely that the loopback is installed backwards. Otherwise, reseal and/or check the connectors.
?0bd-10	An external loopback test has been requested in a mode other than that in which it can perform.	Diagnostics must be run in Manufacturing mode.
?0bd-11	During the external drive test the dictrl reg could not be set to the expected value.	
?0bd-12	During external drive test, we could not zero the sdb register.	
?0bd-13	During external drive test, we could not zero the sc1 reg.	
?0bd-14	This is a test of the ability of the sdb to drive through the fixture and be detected in the SC1 register. One or more of the nine bits have failed when compared with actual data.	
?0bd-15	The dictrl register could not be zeroed.	
?0bd-16	Could not disable SCSI bus driver control in SC2.	
?0bd-17	Could not rezero sdb.	
?0bd-18	Could not rezero sc1.	
?0bd-19	Could not enable external drivers for SCSI bus (SC1 reg).	

(continued on next page)

Table D-7 (Cont.). SCSI/SII Error Codes

Error Code	Description	FRU or Error Type
?0bd-1a	Data loopback error detected writing pattern oxaa.	
?0bd-1b	Could not rezero SC1.	
?0bd-1c	Could not rezero SDB.	
?0bd-1d	Data loopback error detected writing pattern ox55.	
?0bd-1e	Could not rezero SC1.	
?0bd-1f	Data loopback error detected writing pattern 0xff.	
?0bd-20	Could not rezero sdb.	
?0bd-21	Could not set dictrl reg to exp value.	
?0bd-22	Could not drive BSY line high during exdrv test.	
?0bd-23	Could not drive SEL cntl line during exdrv test.	
?0bd-24	Could not drive RST cntl line during exdrv test.	
?0bd-25	Unable to steer drivers for initiator mode signal testing.	
?0bd-26	Unable to rezero SC1 register.	
?0bd-27	Unable to drive ACK cntl line during exdrv test.	
?0bd-28	Unable to drive ATN line during exdrv test.	
?0bd-2 ^a	Unable to enable tgt drvrs for exdrv tst.	
?0bd-2a	Unable to rezero SC1.	
?0bd-2b	Unable to drive REQ cntl line during exdrv test.	
?0bd-2c	Unable to drive MSG cntl line during exdrv test.	
?0bd-2d	Unable to drive C/D cntl line during exdrv test.	

(continued on next page)

Table D-7 (Cont.). SCSI/SII Error Codes

Error Code	Description	FRU or Error Type
?0bd-2e	Unable to drive I/O line during exdrv test.	
?0bd-2f	The SII id reg is not set to the expected value.	
?0bd-30	Unable to drive SCSI bus for arbitration mode.	
?0bd-31	The SII arbitration logic has malfunctioned. It was unable to win the arbitration phase.	
?0bd-32	The SII id register was unable to accept the requested id register value of eeee and retained the value aaaa.	
?0bd-33	The SII arbitration logic is unable to win arbitration when arbitrating as aaaa. Note that a single bit is set in SDB in relation to the SII bus address, e.g., aaaa=01 says the SII is arbitrating as device addr 1, 0x40 says dev 6, etc.	
?0bd-34	A buffer data error has been detected while running the SII buffer addressing test.	Possible SII buffer address logic failure instead of data related memory failure. xxxx is the failing SII buffer address.
?0bd-35	A buffer data error has been detected. Probable SII memory address logic failure instead of a data related failure.	
?0bd-36	The CSR register did not respond to a device reset.	
?0bd-37	During a device test the recovered data as captured in the SII memory buffer does not match the expected data.	Probable SII memory failure. Actual and expected data is printed in the next output line.
?0bd-38	Unable to clear the SII interrupt from the R2000 cause register.	Likely to be an SII interrupt line failure.

(continued on next page)

Table D-7 (Cont.). SCSI/SII Error Codes

Error Code	Description	FRU or Error Type
?0bd-39	Could not enable external SCSI bus drivers.	
?0bd-3b	Data readback to the buffer from the SII during target test does not match expected data.	Possible SII buffer memory error.
?0be-01	During the internal test mode the SII has failed to respond to external stimulus by asserting the acknowledge signal.	Target mode test.
?0be-02	During the internal test mode the SII has failed to respond to external stimulus by deasserting the acknowledge signal.	Target mode test.
?0be-03	During the internal test mode the SII has failed to respond by asserting the request signal.	Initiator mode test.
?0be-04	During the internal test mode the SII has failed to respond by deasserting the request signal.	Initiator mode test.
?0be-05	During the internal test mode the SII failed to respond to selection by asserting BUSY.	During this test the SII is a target with address 7 being selected by the R2000 cpu as address 0.
?0be-06	During the internal test mode the SII failed to transition to a data in/out phase.	The SII is operating as a target.
?0be-07	During internal test mode the SII failed to transition to a STATUS phase.	The SII is operating as a target.
?0be-08	The SII failed to disconnect by releasing busy following completion of a status in phase.	The SII is operating in the target mode.
?0be-09	After successfully arbitrating for the bus, the SII has failed to drive the SEL signal to initiate the selection phase.	The SII is operating in the initiator role.

(continued on next page)

Table D-7 (Cont.). SCSI/SII Error Codes

Error Code	Description	FRU or Error Type
?0bf-01	During the manufacturing mode of test a loopback was not detected on the SCSI port.	A loopback should be installed only if there are no devices present on the bus.
?0bf-02	An illegal SCSI address has been specified.	SCSI addresses must be in the range of 0-7.
?0bf-03	During an operation on the SCSI bus an unrecoverable bus error has occurred.	An attached device or cable may be the problem. Disconnect cables and devices as required to isolate the problem.
?0bf-04	An unexpected bus reset or bus error has occurred.	Most likely caused by a bad peripheral. Often caused by improper power sequencing when starting up the system. Follow bus troubleshooting procedure.
?0bf-05	During a SCSI data out phase, the number of bytes available for transfer does not match that expected for the command or data block.	A SCSI interface error has occurred here. Reset and retry the operation.
?0bf-06	During a SCSI data in phase the number of bytes available for transfer does not match that expected for the command or data block.	A SCSI interface error has occurred here. Reset and retry the operation. If multiple bus devices are present, disconnect all except the device of interest.
?0bf-07	During command out phase the number of command bytes available for transfer exceeds the expected count.	A SCSI interface error has occurred. Reset and retry the operation. If not successful then check SCSI cables, finally disconnecting all external devices. If the test still fails and there are internal peripherals, then disconnect all except one and run test to the device in question.
?0bf-08	A SCSI bus error in the form of an undefined phase transition has occurred.	Follow bus troubleshooting sequence.

(continued on next page)

Table D-7 (Cont.). SCSI/SII Error Codes

Error Code	Description	FRU or Error Type
?0bf-09	A SCSI bus error in the form of an undefined message out phase transition has occurred.	Follow recommended bus troubleshooting procedure.
?0bf-0a	The target has transitioned to an unexpected message in phase and reported the message xxxx.	Follow recommended bus troubleshooting procedure.
?0bf-0b	At the completion of a command or data phase, the expected number of data bytes has not been transferred.	Follow recommended bus troubleshooting procedure.
?0bf-0c	A SCSI bus protocol error has been detected.	Follow recommended bus troubleshooting procedure.
?0bf-0d	The SII failed to return to a disconnect state after an unsuccessful attempt at selection.	Follow recommended bus troubleshooting procedure. If unsuccessful, there is a possible SII problem. If test fails with no devices connected to the bus then check SCSI connector for bent pins. Otherwise, replace system board.
?0bf-0e	The SCSI bus has transitioned to an unexpected/illegal phase while awaiting target selection response.	Follow recommended bus troubleshooting sequence.
?0bf-0f	The attached target device has failed to transition to an expected next phase within the allotted timeout period.	Follow recommended bus troubleshooting procedures.
?0bf-10	The target has transitioned to a phase other than that expected.	Follow recommended bus troubleshooting procedure.
?0bf-11	During a data transfer operation DNE status was not detected in the SII dstat register within the allotted timeout period.	Follow the recommended bus troubleshooting procedure.
?0bf-12	General device failure. Communication with the device was terminated abnormally and there is no available status to report. In other words, we don't know what happened.	Follow bus troubleshooting procedure.

(continued on next page)

Table D-7 (Cont.). SCSI/SII Error Codes

Error Code	Description	FRU or Error Type
?0bf-13	In the SCSI cmd line input there are too many or too few arguments specified for the given command.	
?0bf-14	An invalid option argument has been specified on the command line input for a "scsi" command.	Submit a valid argument.
?0bf-15	A SCSI address outside the range 0-7 has been entered.	Reenter proper range.
?0bf-16	The command mnemonic entered is not an available SCSI command choice.	Reenter command.
?0bf-17	An attempt to execute a command intended for DEC peripherals has been rejected.	
?0bf-18	An illegal block size has been specified during a SCSI I/O test.	This message should never occur during system operation. If displayed, install a new set of diagnostic prompts and retry the operation. If still defective, replace the system board.
?0bf-19	The diagnostic code has received a request to write block sizes greater than 8192 bytes.	This message should never occur during system operation. If displayed, follow instructions for 0bf-018.
?0bf-1a	A request sense operation for device u# has failed with a check error condition and no sense information is available.	Follow recommended bus troubleshooting sequence.
?0bf-1b	The SCSI command specified is not a valid command for a device of the type at the specified address.	Reenter command.

(continued on next page)

Table D-7 (Cont.). SCSI/SII Error Codes

Error Code	Description	FRU or Error Type
?0bf-1c	A request sense command has been rejected because the device of interest reports bsy status.	Attempt manual device setup using "scsi su u#" command. Note: some devices require a lot of time. Visually check the front panel on-line indicators for the device prior to attempting the manual setup operation. Sequential devices such as tape are a good example. If device does not report ready, replace as required.
?0d3-01	Device u# is not on-line and unable to respond to a command sequence.	Check device power, cabling, installation of correct media (if rmb) and correct as necessary to bring device on-line. Attempt manual bring on-line using "scsi su u#" command sequence. If still unsuccessful, replace device as required.
?0d3-02	During a request to self-test device u# an error status is returned in response to the request. Subsequent interrogation reveals that no sense data is available from the device.	This indicates that the device is in a "hung condition". If possible reset the device manually. Reset the SCSI bus using "scsi rs" or reset the hardware using the back panel reset. If unsuccessful replace device as required.
?0d3-03	Off-line self-test for u# has failed.	Check device cabling and power. Check device response using scsi pb. Retry the failing operation. If unsuccessful replace device.
?0d3-04	The canned drive test has returned failing status.	Check prior error message output to get specific cause of failure.
?0d3-05	Device u# reports that it is a type n SCSI device. We do not support this class of device. This is a device error.	Reset and retry. If unsuccessful, replace drive.

(continued on next page)

Table D-7 (Cont.). SCSI/SII Error Codes

Error Code	Description	FRU or Error Type
?0d3-06	Device u# has returned busy status for a period exceeding the allowed diagnostic time-out.	Check device u# status using "scsi ry u#" command sequence. If device is a tape or otherwise has a front panel indicator, check for the indicated status. If device remains busy it is hung. Attempt SCSI bus reset using scsi rs or back panel reset. check cables and retry failing operation. If unsuccessful, replace device.
?0d3-07	The device returned status code aaaa in response to a command is an unrecognized status code.	Retry the operation after resetting using scsi rs and/or back panel reset. If unsuccessful replace device.
?0d3-08	Device u# returns error condition in response to a request for sense data.	The device is hung. Try scsi rs and back panel reset. Check device cabling and power. Attempt scsi iq u# to test for a device response. If none replace device.
?0d3-09	After repeated attempts to bring device u# on-line a check of sense data reveals an abnormal sense condition. If the device is busy coming on-line then it would report sense "busy". This is a device u# failure.	Check cables, connectors and power. Retry the operation that raised this condition. If unsuccessful, replace device.
?0d3-0a	Hard drive rz u# is not ready.	Correct condition as required or replace unit.
?0d3-0b	The format of the sense data returned by this device is not extended class as defined by the SCSI standard. This is probably not a DEC approved SCSI device.	If device is approved, retry operation causing the error condition. If repeatable, device has failed. Replace as required.
?0d3-0f	A check of a SCSI device reveals no response at that address within an allotted timeout period.	Check command line input for the correct address parameter. Check scsi pb to verify that the peripheral responds at the expected address. Correct device address jumpers, cables, connectors as required.

(continued on next page)

Table D-7 (Cont.). SCSI/SII Error Codes

Error Code	Description	FRU or Error Type
?0d3-10	During a format operation, the device is detected off-line.	Bring the device on-line.
?0d3-11	Device fails to respond to an inquiry during a format operation. This is a device failure.	Reset and retry.
?0d3-12	A removable media device has failed to respond to a device inquiry.	Reset and retry operation. Attempt scsi iq/scsi ry operations to the desired device. Replace as required.
?0d3-13	Tape drive u# reports not ready status.	Correct condition as required. If unsuccessful, replace device.
?0d3-14	An attempt to change mode select parameters on u# is unsuccessful.	Reset and retry operation that raised error. Replace device as required.
?0d3-15	No response is given to a request sense command during an attempt to sense write protect status of the media.	Reset and retry failing operation. Replace device as required.
?0d3-16	Device u# has write protected media.	Correct and retry as required.
?0d3-17	A rewind operation on a tape u# has failed.	Reset and retry. Replace device.
?0d3-18	Filemark write operation on a tape drive has failed.	Reset and retry. Replace media and/or drive as required.
?0d3-19	Tape write operation failed. The tape returned bad status in response to a write command.	Reset and retry replacing media and/or drive as required.
?0d3-1a	Tape tz# encountered read error on block number(blkno).	Reset retry replacing media and/or drive as required.
?0d3-1b	A data compare error has occurred while comparing the readback buffer area with expected data. Possible SII memory buffer fault.	Reset and retry failing operation. If unsuccessful, replace media and/or drive. If still unsuccessful, replace system module.
?0d3-1c	CD-ROM device rrd# is not on-line.	Check media, cabling, power and front indicators. Correct as necessary. if still unsuccessful, replace drive.

(continued on next page)

Table D-7 (Cont.). SCSI/SII Error Codes

Error Code	Description	FRU or Error Type
?0d3-1d	Off-line self-test (user mode) for a CD-ROM device rrd# has failed.	Reset and retry failing operation. Replace drive if unsuccessful.
?0d3-1e	This is a general hardware failure. The format operation was not successful.	Replace the unit as required. Note: format operation should never be attempted in the field.
?0d3-1f	The extended self test for device u# has failed.	Check to see that the correct test media is installed if applicable. Reset and retry. Replace drive if test still fails.
?0d3-20	The device does not respond to an inquiry command.	Perform reset, and check device response using scsi pb. Check cabling and power. If still unsuccessful replace device.
?0d3-21	The hard drive reports an error condition in response to a write data SCSI command.	Reset and retry the operation. This is a drive fault. If unsuccessful, replace drive.
?0d3-22	Hard drive rz# reports an error condition in response to a read data SCSI command.	Reset and retry the operation. If unsuccessful, replace drive.

A

Alternate console, 2-5 to 2-6
auto command, 1-15

B

Base system FRU replacement, 3-1 to 3-39
Base system FRUs, 3-4
Battery pack replacement, 3-33
Bezel installation, 3-22
boot command, 1-16
Booting. *See also* Worksystem software, 1-36
 unsuccessful, 1-36
 worksystem software, 1-36

C

Configuration table, 1-28
Console command conventions, 1-15
Console commands
 ?, 1-21
 auto, 1-15
 boot, 1-16
 ctrs, 1-17
 d (deposit), 1-18
 disable, 1-18
 dump, 1-19

Console commands (Cont.)

 e (examine), 1-19
 enable, 1-19, 1-20
 fill, 1-20
 go, 1-21
 help, 1-21
 init, 1-22
 printenv, 1-22 to 1-26
 setenv, 1-26
 test, 1-27
 unsetenv, 1-28
 warm, 1-29
Console extended self-tests, 2-1 to 2-30
 described
 cache test (c), 2-15
 color mask (C), 2-14
 CSR test (R), 2-24
 disk RAM test (d), 2-17
 DZ test (d), 2-16
 ESAR (e), 2-17
 FPU (F), 2-18
 keyboard (k), 2-19
 LANCE (L), 2-19
 LEDs (l), 2-20
 main RAM (m), 2-21
 memory report (b), 2-14
 mouse (P), 2-22
 net RAM (n), 2-22
 PCC (p), 2-23

Console extended self-tests
described (Cont.)

RTC (r), 2-24
SII test (s), 2-25
system (a), 2-13
TLB (t), 2-28
VDAC (V), 2-29
video RAM (v), 2-29
video test patterns (f), 2-18
write buf (w), 2-30

display

memory report, 2-14

preparing to run, 2-7 to 2-10

running, 2-13 to 2-30

cache test, 2-15
color mask test, 2-14 to 2-15
CSR test, 2-24
disk RAM test, 2-17
DZ test, 2-16
ESAR test, 2-17
FPU test, 2-18
keyboard test, 2-19
LANCE test, 2-20
LEDs test, 2-20 to 2-21
main RAM test, 2-21
mouse test, 2-22
net RAM test, 2-22
PCC test, 2-23
RTC test, 2-25
SII test, 2-25 to 2-28
system test, 2-13 to 2-14
TLB test, 2-28
VDAC test, 2-29
video RAM test, 2-29 to 2-30
video test patterns test, 2-18
write buf test, 2-30

test modes, 2-9 to 2-31

selecting, 2-9

terminators, 2-11

viewing test commands, 2-7

Console extended self-tests menus
diagnostics options, 2-7 to 2-8

Console menu, 1-14 to 1-29

command conventions, 1-15

Console menu (Cont.)

using, 1-14

Cover replacement, 3-5

ctrs command, 1-17

D

d (deposit) command, 1-18

Diagnostics

See also Tests

aids, 2-5

connecting an alternate console, 2-5

netstat, 2-5

options menu, 2-8

uerf, 2-5

disable command, 1-18

Disk drive

mounting panel, 3-1

Disk Drive Removal, 3-18

Disk drive replacement

floppy panel, 3-14

Drive mounting panel replacement, 3-6

D SIM module replacement, 3-27

dump command, 1-19

E

e (examine) command, 1-19

enable command, 1-20

Environment variables, 1-24 to 1-26

Environment variable table, 1-23

Equipment specifications

LK201 keyboard, A-14 to A-15

monitor VR299, A-12 to A-13

RRD40 optical compact disc drive,
A-23

RX23 Diskette drive, A-30 to A-31

RZ23 hard disk drive, A-24 to A-25

RZ23L hard disk drive, A-26 to
A-27

RZ24 hard disk drive, A-28 to A-29

RZ55 hard disk drive, A-18 to A-19

system unit, A-2

TK50Z tape drive, A-20 to A-21

TLZ04 cassette tape drive, A-22

Equipment specifications (Cont.)

- VR150 monitor, A-3 to A-4
- VR160 monitor, A-5 to A-7
- VR262 monitor, A-8 to A-10
- VR297 monitor, A-10 to A-11
- VSXXX-AA mouse, A-16 to A-17

ESAR chip, 3-36

Extended self-tests, 2-1 to 2-50

See also Console extended self-tests;
SCSI extended self-tests

interpreting status LED codes, 2-47

overview, 2-1

running without monitor, 2-47 to
2-50

F

Fans troubleshooting, 1-3

fill command, 1-20

Floppy disk SCSI ID, 3-20

FRUs, base system, 3-1 to 3-39

list of, 3-4

replacement, 3-1 to 3-39

battery pack, 3-33 to 3-34

drive mounting panel, 3-6

D SIM module, 3-27 to 3-28

ESAR chip, 3-36 to 3-37

internal RX23 disk drive, 3-14
to 3-27

internal RZ23 disk drive, 3-8 to
3-12

power supply assembly, 3-39

preparing for, 3-1 to 3-3

system module, 3-35 to 3-37

system unit cover, 3-5

video SIM module, 3-31

G

General maintenance, 1-1

go command, 1-21

H

Hardware problems

See FRUs, base system, replacement

help command, 1-21

I

init command, 1-22

Intermittent errors, 2-5

Internal RX23

add-on, 3-20

replacing, 3-17

Internal RZ23 disk drive replacement,
3-8

K

Keyboard troubleshooting, 1-13

M

Memory troubleshooting, 1-13

Monitor troubleshooting, 1-3

Mouse troubleshooting, 1-11, 1-13

O

On/off switch, 1-5

P

Part numbers

basic components, B-4

cords, cables, and connectors, B-5,
B-6

hardware, B-1 to B-6

hardware documentation, B-8

loopback connectors, B-1

major FRUs, B-3

software documentation, B-7

Power supply assembly replacement,
3-39

Power-up self-test, 1-5 to 1-9

display, 1-6, 1-8

failure of, 1-7

interpreting results, 1-11 to 1-12

running, 1-5

unsuccessful, 1-7

printenv command, 1-23 to 1-26

Printer/console connector location, 2-5

R

R2000 CPU registers, C-1 to C-15

Bad Virtual Address, C-7

Cause, C-12

Context, C-7

EntryHi, C-3

EntryLo, C-4

Number (table), C-1

Status, C-9

TLB Index, C-5

TLB Random, C-5

Reduced instruction set computer. *See*
RISC

Reset button, 1-7, 1-10

RISC, 1-1

S

scsi cd (canned disk test), 2-33

scsi cf (canned floppy disk test), 2-34

SCSI commands, 1-32 to 1-35

table of, 1-32

scsi cr (canned CDROM disc test), 2-36

scsi ct (canned tape test), 2-35

scsi ex (extended self-test), 2-36

SCSI extended self-test

canned tape test, 2-35 to 2-37

SCSI extended self-tests, 2-4 to 2-50

described, 2-4

canned CDROM disc (cr), 2-36

canned disk (cd), 2-33

canned disk (cf), 2-34

canned tape (ct), 2-35

Digital peripherals (ex), 2-36

t1, 2-37

t2, 2-38

t3, 2-39

t4, 2-41

preparing to run, 2-31 to 2-32

running with monitor, 2-32 to 2-42

canned CDROM disc test, 2-36

canned disk test, 2-33

SCSI extended self-tests

running with monitor (Cont.)

canned tape test, 2-35

t1 test, 2-37 to 2-38

t2 test, 2-38 to 2-39

t3 test, 2-40 to 2-41

t4 test, 2-41 to 2-42

running without monitor, 2-47 to
2-50

viewing storage device listing, 2-31

SCSI menu, 1-30 to 1-35

using, 1-30

SCSI storage device listing, 2-31

scsi t1, 2-37

scsi t2, 2-38

scsi t3, 2-39

scsi t4, 2-41

SCSI test levels, 1-30

SCSI tests

audience level, 1-30

modes, 1-30

Self-test, 1-10 to 1-13

codes, 1-11

failure, 1-10

interpreting results, 1-11 to 1-12

interpreting status LED display,
1-13

running, 1-10

status LED display codes, 1-13

setenv command, 1-26

Shutdown commands, 1-3

Shutting down the worksystem software,
1-3

commands, 1-4

Small computer system interconnect.

See SCSI

Status LED display, 1-8 to 1-13, 2-47
to 2-50

interpreting extended self-test, 2-47
to 2-50

display codes, 2-47 to 2-50

interpreting self-test display codes,
1-13

System module replacement, 3-35

System unit troubleshooting, 1-13

T

- t a (system test), 2-13
- t b (memory report), 2-14
- t c (cache test), 2-15
- t C (color mask test), 2-14
- t d (disk RAM), 2-17
- t D (DZ test), 2-16
- t e (ESAR), 2-17
- Terminating connectors, 2-11
- test -a command, 1-10
- test command, 1-27
- Test modes, 2-9
- t F (FPU), 2-18
- t f (video test patterns test), 2-18
- t k (keyboard test), 2-19
- t L (LANCER), 2-19
- t l (LEDs), 2-20
- t m (main RAM test), 2-21
- t n (net RAM test), 2-22
- t P (mouse test), 2-22
- t p (PCC test), 2-23
- t R (CSR test), 2-24
- t r (RTC test), 2-24
- Troubleshooting
 - fans, 1-2, 1-3
 - intermittent errors, 2-5
 - keyboard, 1-12, 1-13
 - memory, 1-13
 - monitor, 1-2, 1-3
 - mouse, 1-11, 1-12, 1-13
 - SCSI
 - devices, 2-4
 - system unit, 1-11, 1-12, 1-13
 - console extended self-tests, 2-1 to 2-4
 - video SIM module, 1-11
 - visual checks, 1-2
- t s (SII test), 2-25
- t t (TLB test), 2-28
- Turning on. *See* Workstation
- t V (VDAC test), 2-29
- t v (video RAM test), 2-29
- t w (write buf test), 2-30

U

- Unit select jumpers, 3-10
- unsetenv command, 1-28

V

- Video SIM
 - module replacement, 3-31
 - troubleshooting, 1-11
- Visual checks, 1-2

W

- warm command, 1-29
- Workstation, turning on, 1-5
- Worksystem software
 - boot failure, 1-36
 - booting, 1-36
 - shutting down, 1-3