

DECstation 2100/3100

Hardware Installation Guide

First printing, January 1989

Revised, July 1989

Revised, January 1991

The information in this document is subject to change without notice and should not be construed as a commitment by Digital Equipment Corporation. Digital Equipment Corporation assumes no responsibility for any errors that may appear in this document.

The software described in this document is furnished under a license and may be used or copied only in accordance with the terms of such license.

Digital Equipment Corporation assumes no responsibility for the use or reliability of its software on equipment that is not supplied by Digital or its affiliated companies.

© Digital Equipment Corporation 1989, 1991.

All Rights Reserved

Printed in U.S.A.

U.S.A.

This equipment generates, uses, and may emit radio frequency energy. The equipment has been type tested and found to comply with the limits for a Class A computing device pursuant to Subpart J of Part 15 of FCC Rules, which are designed to provide reasonable protection against such radio frequency interference. Operation of this equipment in a residential area may cause interference in which case the user at his own expense will be required to take whatever measures may be required to correct the interference.

The following are trademarks of Digital Equipment Corporation:

DEC
DECnet
DECstation
DECsystem
DECUS
MicroVAX
MicroVMS

PDP
ThinWire
ULTRIX
ULTRIX-32
UNIBUS
VAX
VAXBI

VAXcluster
VAXstation
VMS
VT

The logo for Digital Equipment Corporation, featuring the word "digital" in a stylized, lowercase font with a registered trademark symbol.

Contents

Using This Guide	ix
-------------------------------	----

1 Getting Started

Review Site Requirements	1-1
Temperature	1-1
Humidity	1-2
Cleanliness	1-2
Power	1-2
Supplies	1-2
Unpack and Check Your Equipment	1-3

2 Installing the Basic DECstation 2100/3100 Hardware

Set Up the System Unit	2-2
Connect the Keyboard to the System Unit	2-3
Connect the Mouse to the System Unit	2-4
Connect the Ethernet Loopback Connector and Terminators	2-5
To Install the ThickWire Ethernet Loopback Connector	2-6
To Terminate ThinWire Ethernet	2-7
Terminate the SCSI Connector on the System Unit	2-9
Connect the Video Cable to the System Unit	2-11
Set Up the Monitor	2-13
Connect the Video Cable to the Monitor	2-15
To Connect a Video Cable to a Monochrome Monitor ...	2-15
To Connect a Video Cable to a Color Monitor	2-17
Connect the Power Cable and Power Cord	2-20

To Connect the Monitor–System Unit Power Cable	2-21
To Connect the System Unit Power Cord	2-22

3 Starting and Testing the Workstation

Turn On the Monitor	3-2
To Turn On a VR150 Monochrome Monitor	3-2
To Turn On a VR262 Monochrome Monitor	3-2
To Turn On a VR160 Color Monitor	3-3
To Turn On a VR297 Color Monitor	3-3
To Turn On a VR299 Color Monitor	3-3
Turn On the System Unit	3-5
If Your System Fails to Turn On	3-6
If Your Monitor Fails to Turn On	3-6
Check the Results of the Power-Up Self-Test	3-7
If a Subtest Is Unsuccessful	3-7
If subtest 7, 6, 5, or 4 fails	3-8
If test 3 fails	3-8
If subtest 2 fails	3-8
If subtest 1 fails	3-8
Arrange for Your Ethernet Connection	3-9
To Find Your Ethernet Station Address	3-9

4 Installing Optional Peripheral Devices

Installing External Storage Devices	4-2
To Connect Expansion Boxes	4-4
To Attach Only One Box	4-13
To Attach More Than One Box	4-15
Reading the configuration table	4-15
Setting the SCSI switches	4-17
Connecting boxes	4-18
Installing a Printer	4-24
Installing a Communications Device	4-26

5 Completing the Hardware Installation

Using Ethernet to Access Your Worksystem Software	5-1
Installing Your Worksystem Software on a Hard Disk	5-2
To Use a Tape Drive	5-2
Finding the unit number of your tape drive	5-3
To Use Ethernet	5-4
Where To Go from Here	5-5

If You Have Factory-Installed Software	5-5
To Perform a Basic Worksystem Software Installation ..	5-5
To Tailor Your Worksystem Software to Meet Special Needs	5-6
To Install Application Software Products	5-6

6 Installation Notes for Experienced Installers

Installing the Basic DECstation 2100/3100	6-1
Installing Optional Peripheral Devices	6-3
To Install External Storage Devices	6-3
Connecting the first expansion box to the system unit	6-3
Connecting boxes after the first	6-4
To Install a Printer	6-4
To Install a Communications Device	6-5

A Ethernet Hardware Connections

Connecting to a ThickWire Network	A-2
Connecting to a ThinWire Network	A-4
To Connect to the End of a ThinWire Segment	A-4
To Connect Within a ThinWire Segment	A-7

Figures

1-1	The basic DECstation 2100/3100 shipment	1-4
2-1	The on/off switch on the system unit	2-2
2-2	Connecting a keyboard to the system unit	2-3
2-3	Connecting a mouse to the system unit	2-4
2-4	Ethernet loopback connector and terminators	2-5
2-5	Attaching a ThickWire loopback connector to the system unit	2-6
2-6	Attaching terminators to the T-connector	2-7
2-7	Attaching a terminated T-connector to the system unit	2-8
2-8	Removing the plastic cover that protects the SCSI connector	2-9
2-9	Installing a SCSI terminator	2-10
2-10	Video cables	2-11
2-11	Connecting a video cable to the system unit	2-12
2-12	The on/off switch on the monitor	2-14

2-13	Connecting a video cable connector	2-15
2-14	Connecting a video cable to a VR150 or VR262 monochrome monitor	2-16
2-15	Connecting a video cable connector	2-17
2-16	Connecting a video cable to a VR160 or VR299 color monitor	2-18
2-17	Connecting a video cable to a VR297 monitor	2-19
2-18	Power cable, power cord, and voltage labels	2-20
2-19	Connecting a power cable to a system unit power outlet	2-21
2-20	Connecting the system unit power cord	2-22
3-1	Contrast and brightness icons	3-2
3-2	Turning on monochrome monitors	3-3
3-3	Turning on color monitors	3-4
3-4	Turning on the system unit	3-5
4-1	Expansion boxes	4-3
4-2	Expansion box cables, cord, and terminator	4-4
4-3	Removing the SCSI terminator	4-5
4-4	ID switch setting for the TK50Z tape drive	4-6
4-5	ID switch setting for the RZ55 hard disk drive	4-7
4-6	ID switch setting for the TLZ04 cassette tape drive	4-8
4-7	ID switch setting for the RRD40 optical compact disc drive	4-9
4-8	Attaching a system unit-expansion box cable to the SCSI connector on the system unit	4-10
4-9	Attaching a system unit-expansion box cable to the SCSI connector on an expansion box	4-12
4-10	Terminating an expansion box	4-13
4-11	Connecting an expansion box power cord	4-14
4-12	Sample configuration display	4-16
4-13	Connecting an expansion box to another expansion box	4-19
4-14	Terminating the final expansion box	4-21
4-15	Connecting the power cord	4-22
4-16	Connecting a printer to the system unit	4-25
4-17	Connecting a communications device to the system unit	4-27
5-1	Sample configuration display	5-3
A-1	Connecting the ThickWire ethernet cable	A-3
A-2	Removing a Terminator from the T-Connector	A-4
A-3	Connecting the ThinWire Cable to the T-Connector	A-5
A-4	Connecting one ThinWire cable	A-6
A-5	Removing the Terminators from the T-Connector	A-7

A-6	Connecting the ThinWire Cables to the T-Connector.....	A-7
A-7	Connecting two ThinWire cables.....	A-9

Tables

1	Conventions Used in This Guide	ix
4-1	SCSI ID Switch Settings	4-18

PAGE viii INTENTIONALLY LEFT BLANK

Using This Guide

To install your new DECstation 2100/3100 workstation, follow the instructions in this guide.

If you are a novice installer, read Chapters 1 through 6.

If you are an experienced installer, turn to Chapter 6. For more detailed information about any procedure, refer to the table of contents.

Table 1. Conventions Used in This Guide

Convention	Use
Monospace type	Anything that appears on your monitor screen is set in monospace, like this.
Boldface type	Anything you are asked to type is set in boldface, like this. All commands typed at the console level are case sensitive. The workstation does not recognize uppercase and lowercase letters as the same input.

Getting Started

This chapter tells you

- How to prepare your site so your workstation can operate efficiently and safely
- How to make sure your shipment contains everything you need and what to do if something is missing or broken

Review Site Requirements

For your DECstation 2100/3100 workstation to work efficiently, your work environment must meet the requirements listed here.

Caution. Failure to meet these requirements can cause damage to equipment.

Temperature

- Keep the temperature around the workstation between 50° and 104° Fahrenheit (10° and 40° Celsius).
 - Set up your workstation away from heaters, photocopiers, and other sources of heat.
 - Protect your workstation from sunlight.

- Allow air to flow freely around your workstation to keep heat from building up and damaging your equipment.
 - Leave 4 inches (10 cm) of space between system unit vents and other objects.
 - Leave 3 inches (8 cm) of space between monitor vents and other objects.

Humidity

- Keep relative humidity within the range of 10 to 95 percent

Cleanliness

- Keep your work area as dust-free as possible.

Power

- Set up your workstation at least 30 inches (90 cm) from other terminals or monitors or other sources of electrical interference.
- Limit exposure to static electricity by setting up your workstation away from busy corridors and other high-traffic areas.
- Provide a 6.5-ampere branch circuit for the exclusive use of your workstation.
- Be sure your electrical circuit is properly grounded and free from electrical noise.

Supplies

- Store supplies, such as tape cartridges, at the same temperature and humidity levels as your workstation.

Unpack and Check Your Equipment

As you unpack your shipment, check its contents against the packing list. Save the packing materials in case you ever need to store or ship your workstation.

Warning: *It takes two people to unpack the system unit and monitor safely.*

Your shipment should include all the items that appear in Figure 1-1, plus your software and any options you have ordered. You do not need to use the power cord that comes with your monitor. In the DECstation 2100/3100 workstation, the monitor receives its power through the system unit, not from a wall outlet. To provide power to the monitor, you use the power cable that comes with your system unit.

Inform the delivery agent and your Digital sales representative if any items are missing or damaged.

For a detailed list of items, with part numbers, available for your workstation, see Appendix B in the *DECstation 2100/3100 Operator's Guide*.

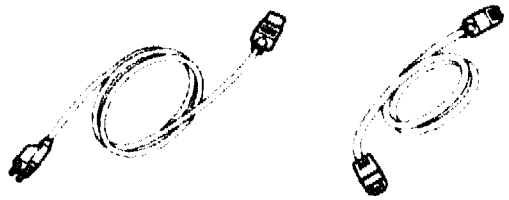
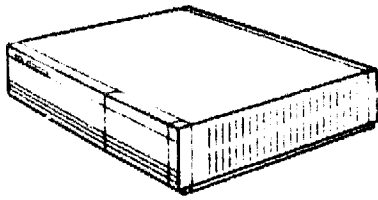

System unit, system power cord, and monitor-system unit power cable

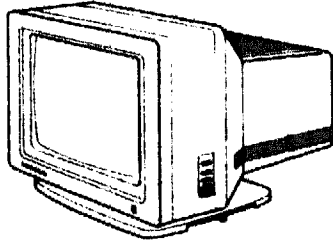

Monitor



Video cable for monochrome monitor



Video cable for color monitor



Keyboard with cable



One ThinWire T-connector and two terminators



Mouse with cable



ThickWire loopback connector

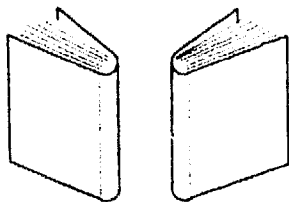

Documentation



Small computer system interface (SCSI) terminator (may already be installed)



Screwdriver

DEPI002

Figure 1-1. The basic DECstation 2100/3100 shipment

Installing the Basic DECstation 2100/3100 Hardware

This chapter tells you how to install the basic DECstation 2100/3100 hardware.

Warning: *Plugging in power cords or turning on power before you are instructed to do so can cause injury and damage equipment.*

Set Up the System Unit

Caution: *Placing the system unit on its side blocks air vents and causes the unit to overheat.*

Place the system unit on a flat surface as near as possible to where you will use it.

- Leave enough space so you can connect the cables to the back of the unit.
- Be sure the on/off switch on the back of the system unit is set to the off (0) position.

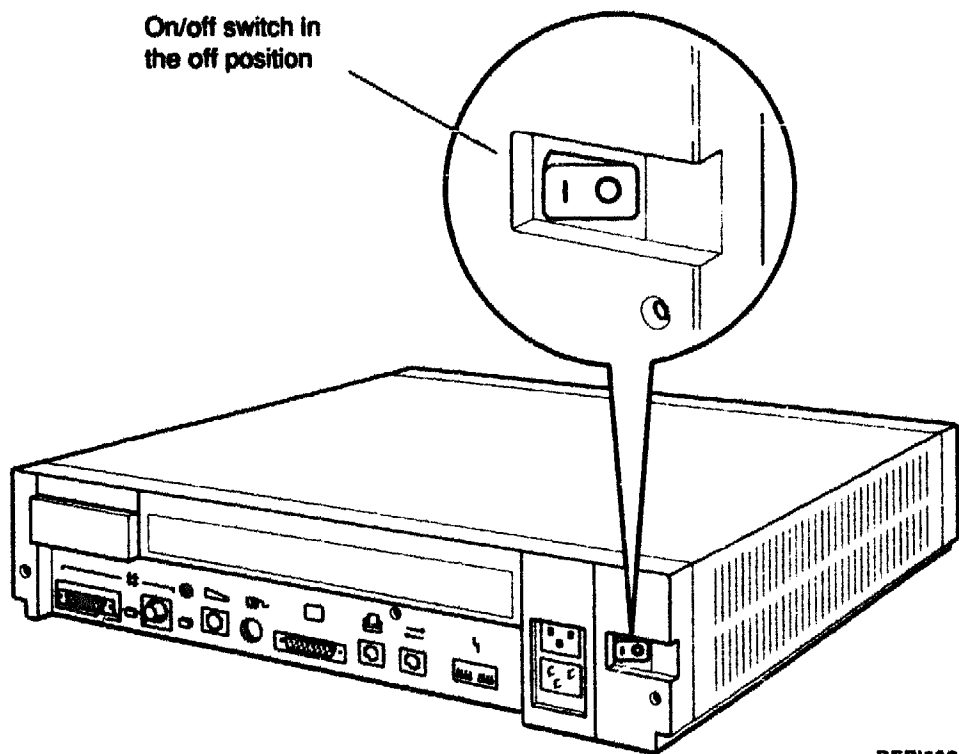

DEPI003

Figure 2-1. The on/off switch on the system unit

Connect the Keyboard to the System Unit

1. Position the keyboard cable connector so the clip is on the bottom.
2. Push the keyboard connector into the connector below the keyboard icon on the back of the system unit until it snaps into place.

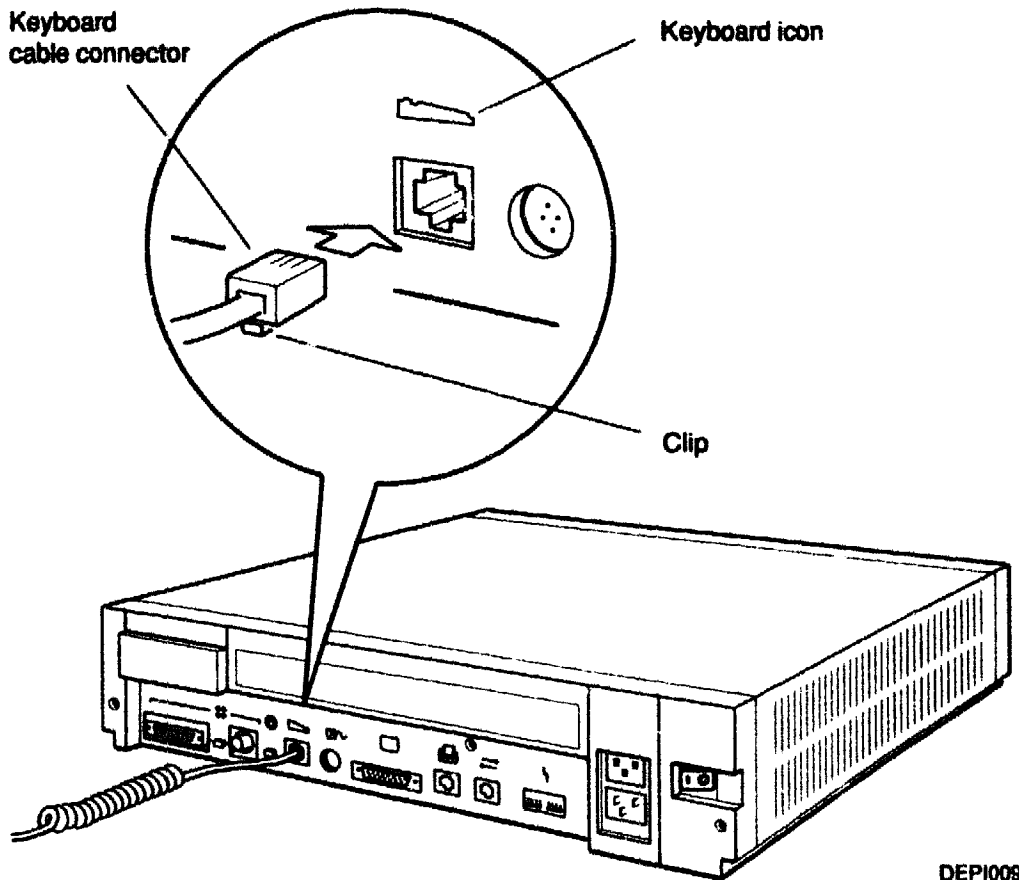

DEPI009

Figure 2-2. Connecting a keyboard to the system unit

Connect the Mouse to the System Unit

1. Carefully align the icon on the top of the mouse cable connector with the mouse icon on the back of the system unit.
2. Push the cable connector all the way into the connector on the back of the system unit.

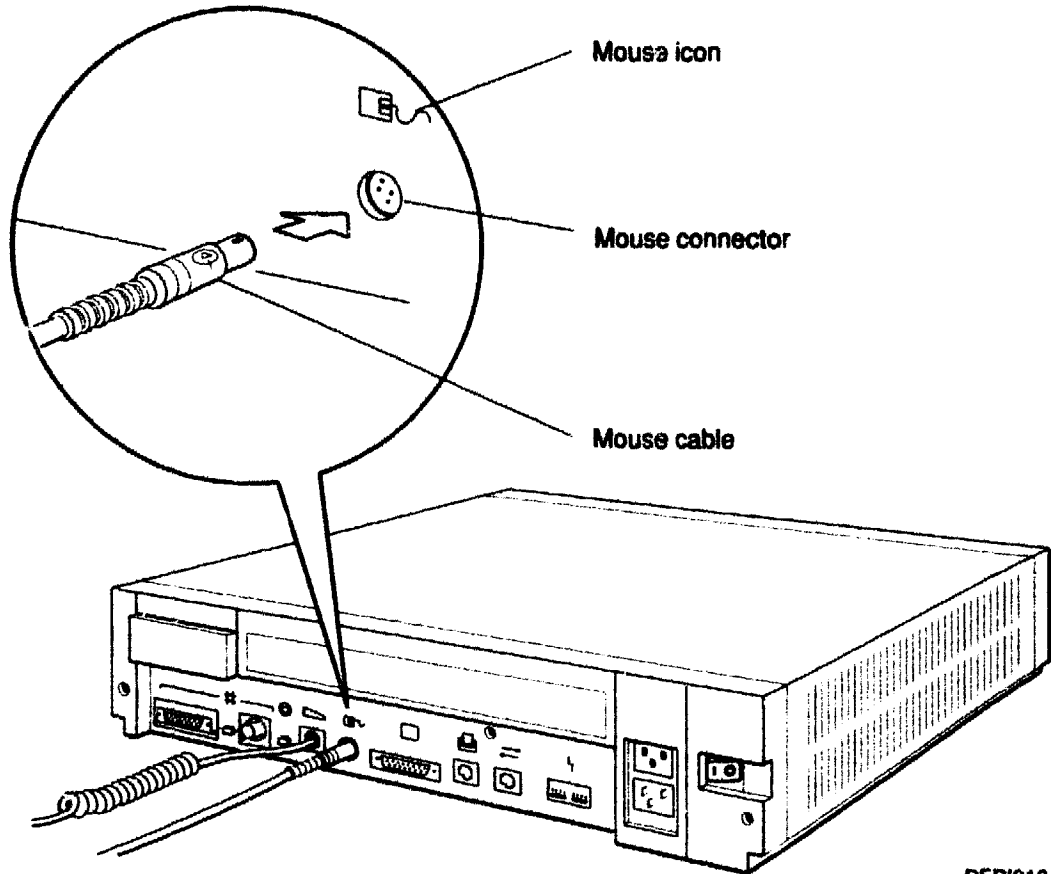

DEPI010

Figure 2-3. Connecting a mouse to the system unit

Connect the Ethernet Loopback Connector and Terminators

A ThickWire loopback connector and a ThinWire T-connector and two ThinWire Ethernet terminators came with your shipment.

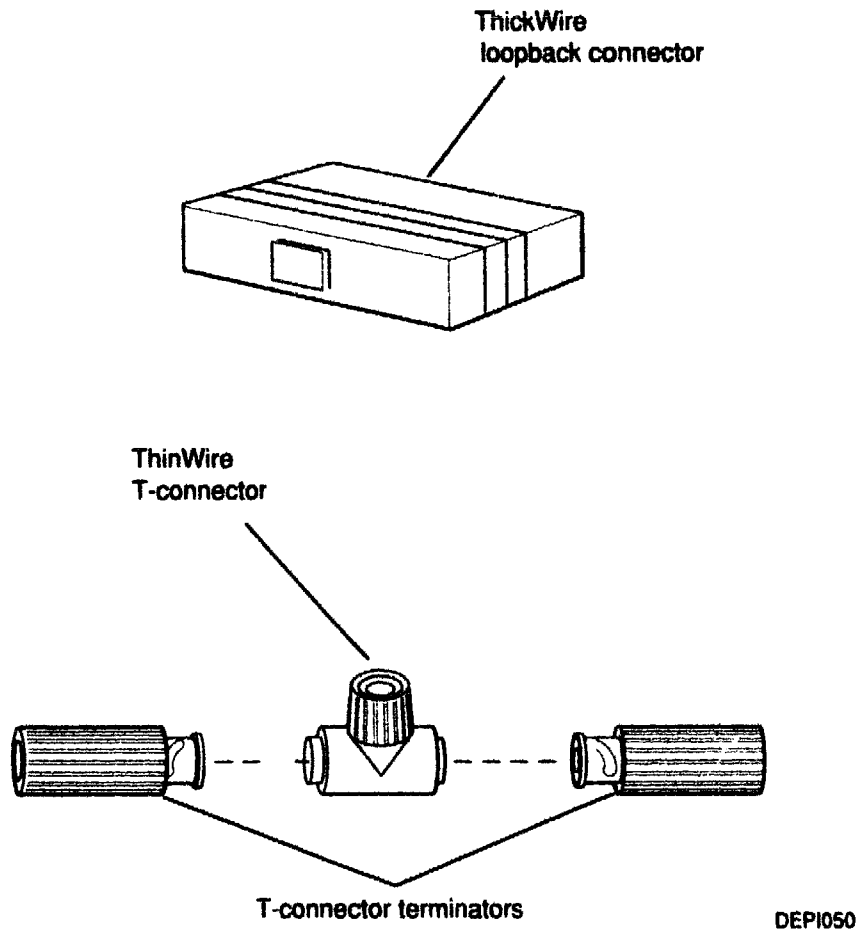
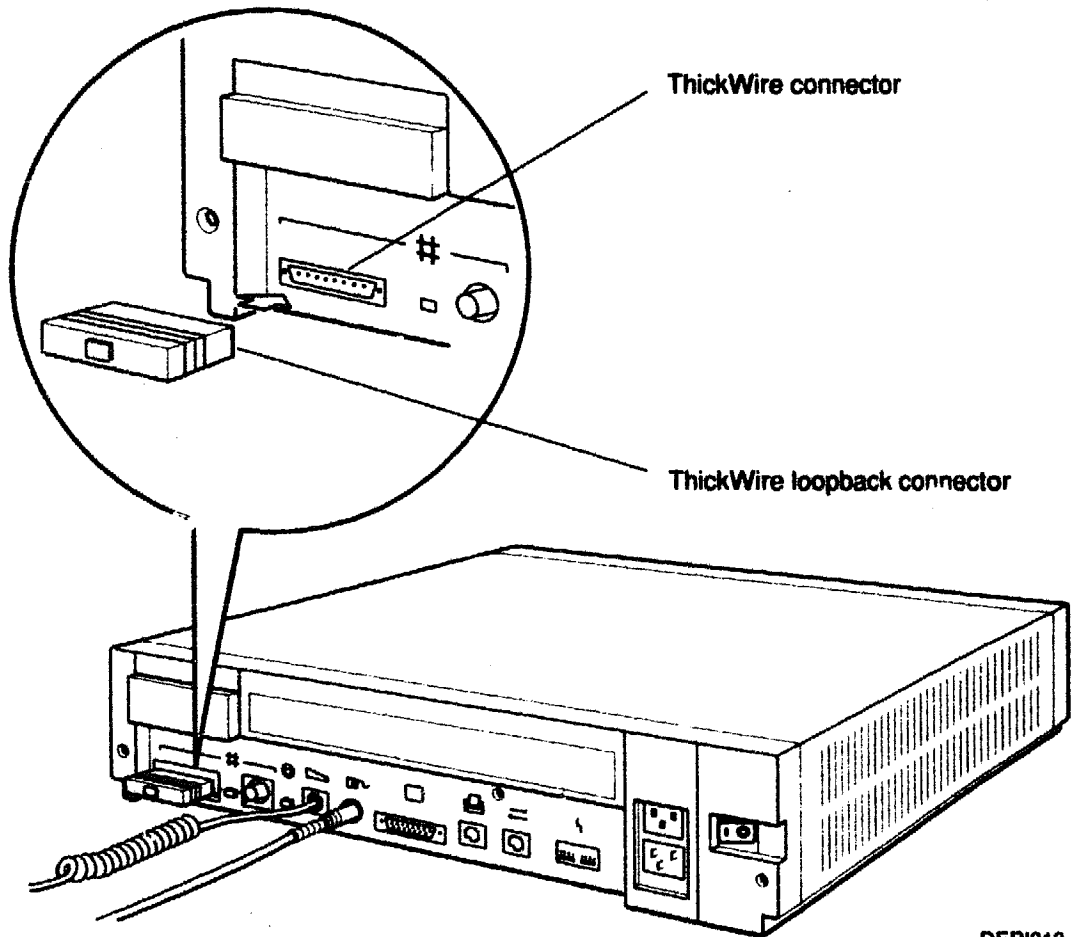

Figure 2-4. Ethernet loopback connector and terminators

To Install the ThickWire Ethernet Loopback Connector

1. Find the square ThickWire loopback connector that came with your shipment.
2. Position the loopback connector so its widest part aligns with the widest part of the ThickWire connector located in the lower-left corner of the back of the system unit.
3. Firmly press the loopback connector into the connector on the system unit.



DEPI013

Figure 2-5. Attaching a ThickWire loopback connector to the system unit

To Terminate ThinWire Ethernet

1. Find the T-connector and two terminators that came with your shipment.
2. Notice how the ribbed portion of the T-connector can be twisted from side to side.
3. Attach the terminators to the T-connector.
 - a. Firmly push each terminator connector onto the T-connector.
 - b. Twist the left-hand terminator toward you and the right-hand terminator away from you until they slide toward the T-connector and lock into place.

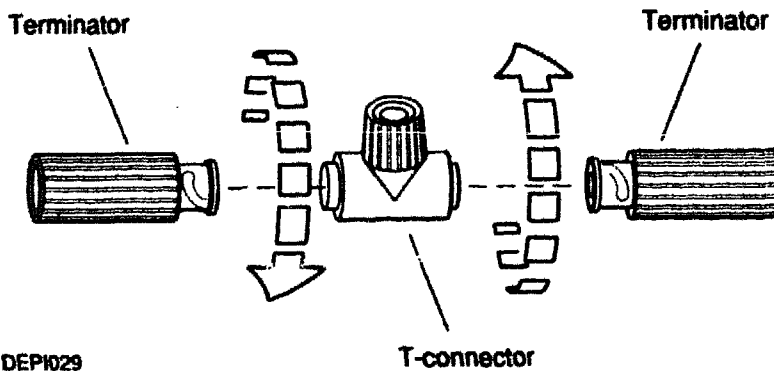
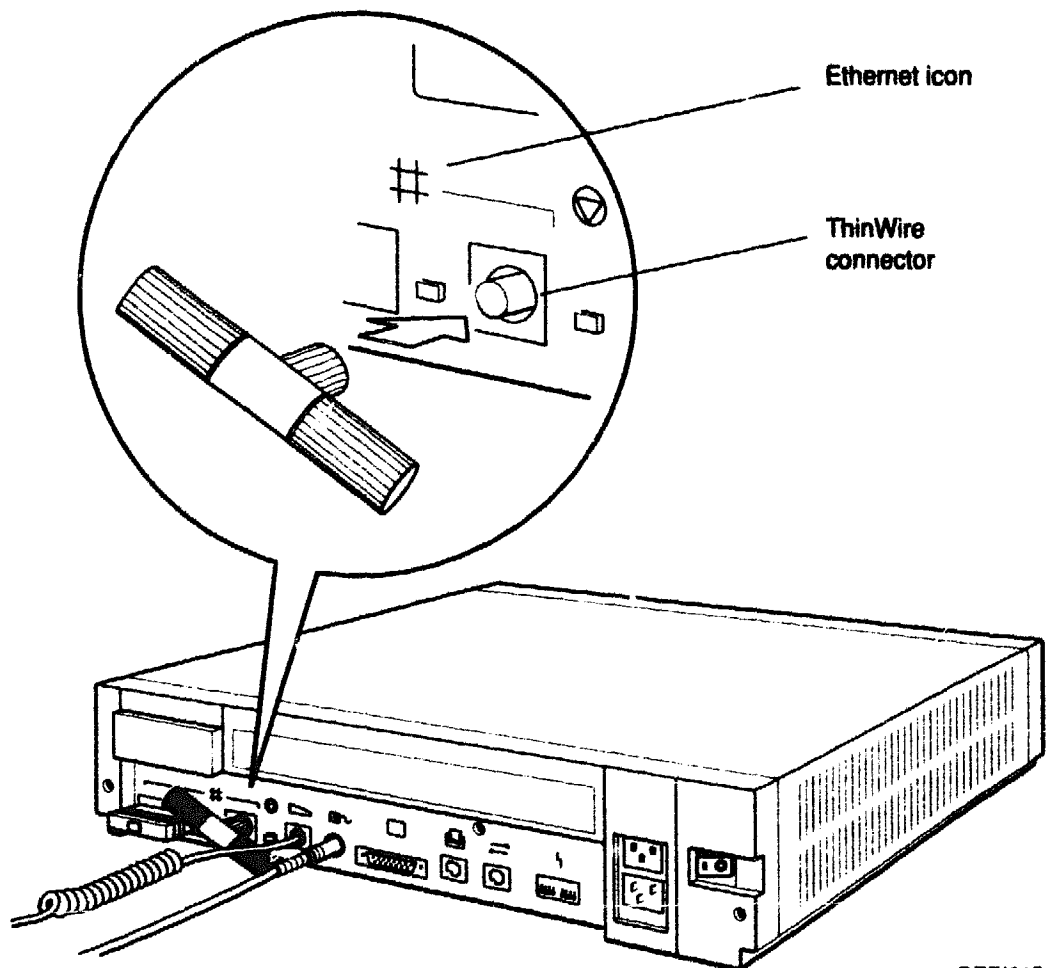

Figure 2-6. Attaching terminators to the T-connector

4. Push the ribbed portion of the terminated T-connector into the ThinWire Ethernet connector below the Ethernet icon on the back of the system unit.

You have to tilt the terminated T-connector slightly to fit it between the ThickWire loopback connector and the keyboard cable.

5. Twist the T-connector from side to side until it slips into place and you can push it onto the connector on the system unit.
6. Twist the ribbed portion of the connector to the right until it locks into place.



DEPI015

Figure 2-7. Attaching a terminated T-connector to the system unit

Terminate the SCSI Connector on the System Unit

1. Remove the plastic cover that protects the SCSI connector located in the upper-left corner of the back of the system unit.
 - a. Run your finger along the bottom of the cover until you feel the latch that lies between the two holes in the bottom of the cover.
 - b. Push up on the latch until it releases from the back cover of the system unit.

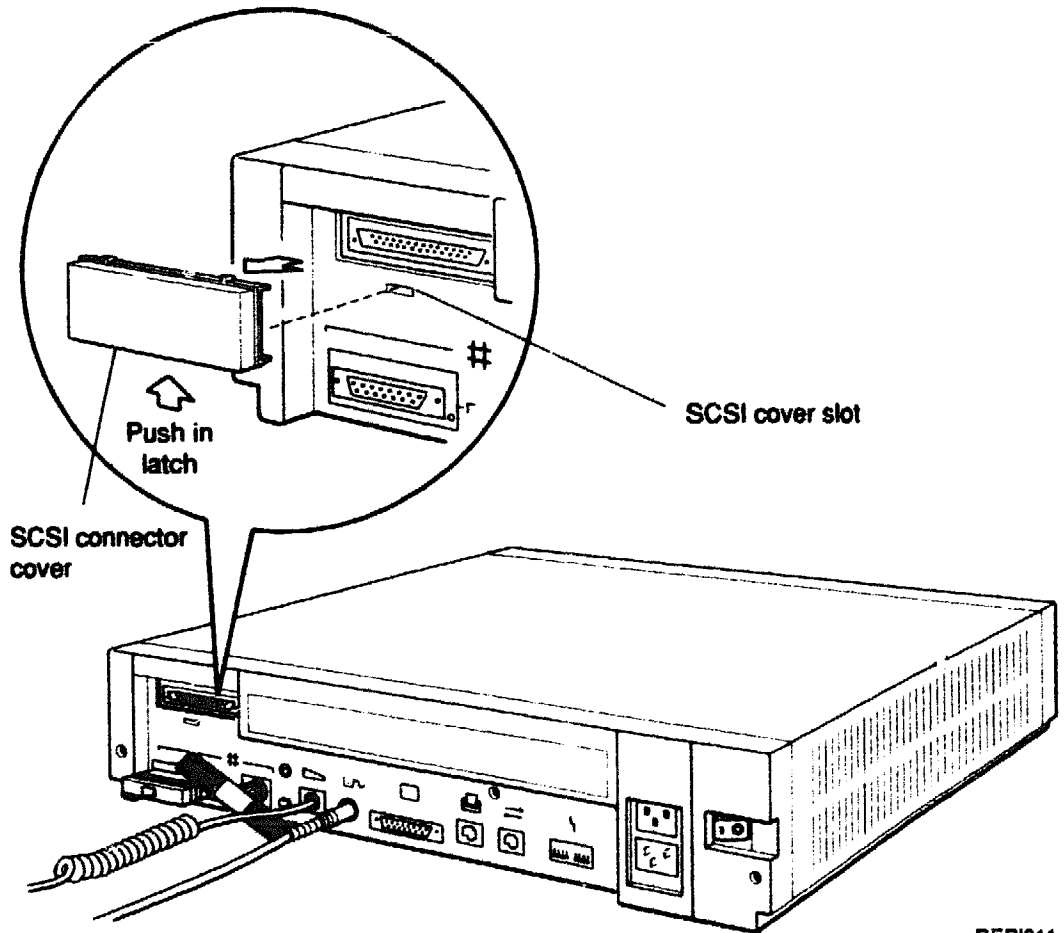
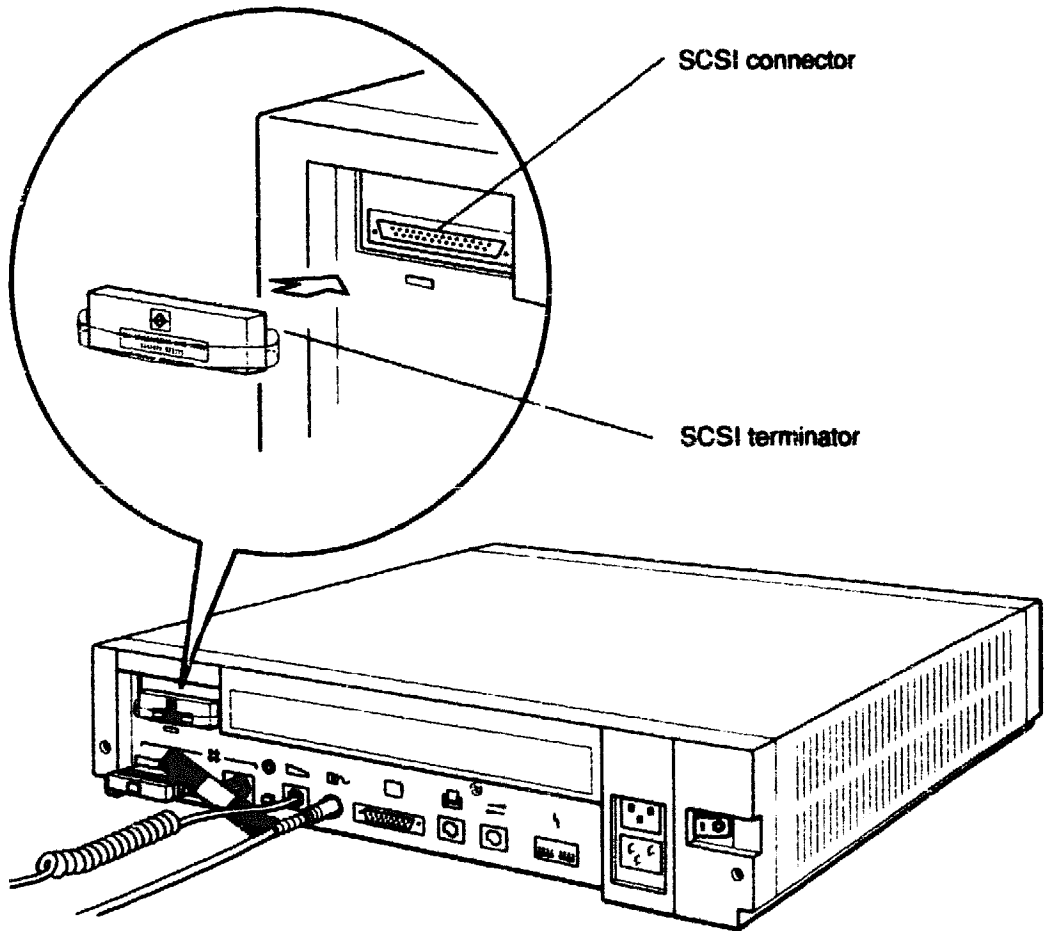

Figure 2-8. Removing the plastic cover that protects the SCSI connector

2. If the SCSI terminator is not already installed, install it by turning it so the widest part of its connector aligns with the widest part of the SCSI connector on the system unit.
3. Push the terminator into the SCSI connector.



DEPI012

Figure 2-9. Installing a SCSI terminator

Connect the Video Cable to the System Unit

Your system unit comes with either a monochrome or a color video cable.

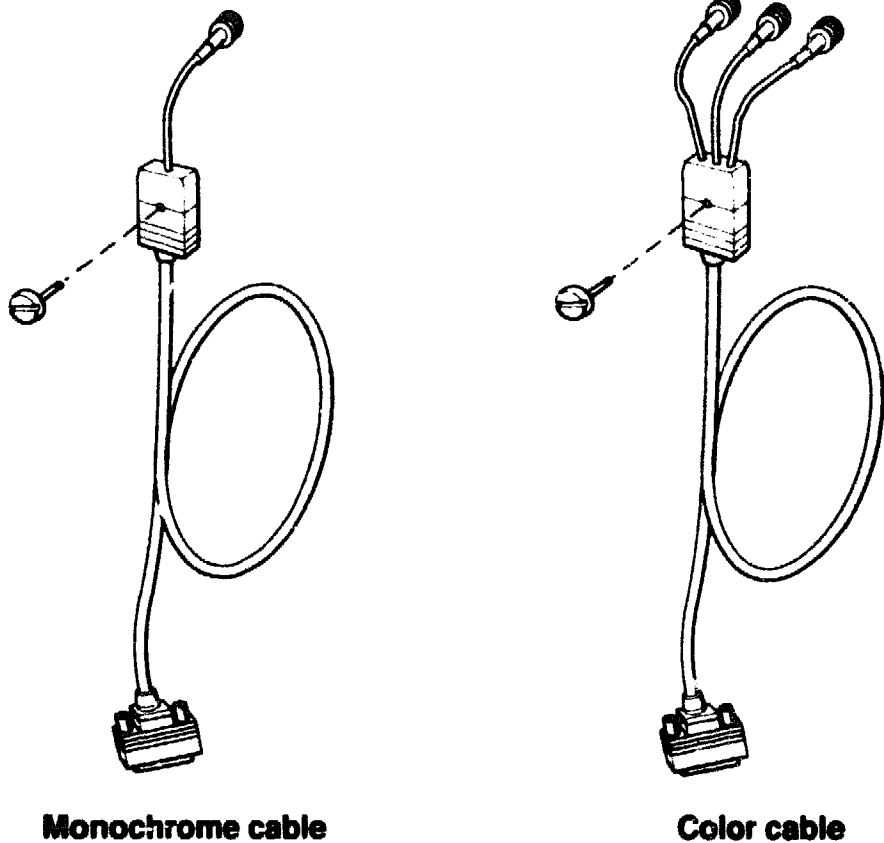

Monochrome cable

Color cable

DEP1005

Figure 2-10. Video cables

1. Find your video cable and the two knobs that came with it. If you have a VR297 monitor, the video cable does not come with knobs. You will not need them for this type of monitor.
 - a. For the VR150, VR160, and VR262 monitors, select the knob with the shortest screw.
 - b. For the VR299 monitor, select the knob with the longest screw.
2. Find the end of the video cable that has a square connector on it.

3. Position the cable connector so the longest side of the connector aligns with the widest part of the video connector on the system unit.
4. Push the cable connector into the connector on the system unit and turn both screws to the right until they are tight. If necessary, use the screwdriver that came with your system to tighten the screws.

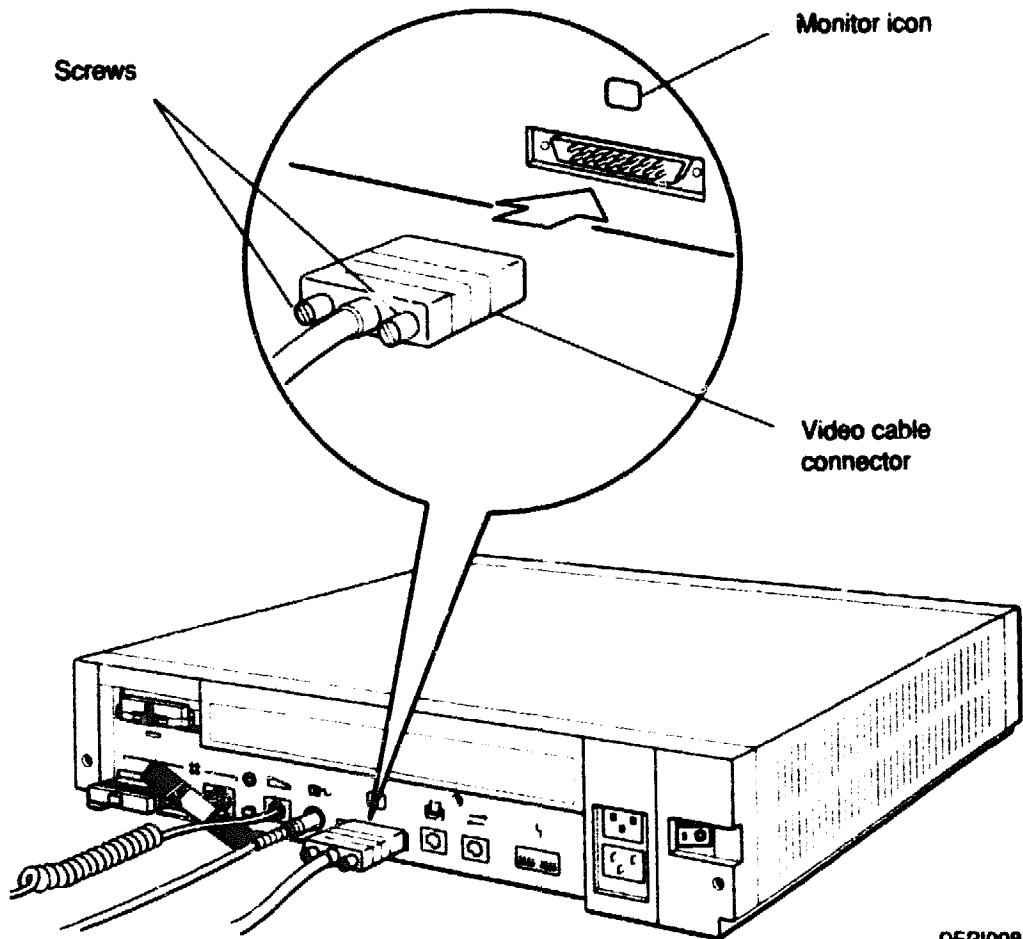

DEPI008

Figure 2-11. Connecting a video cable to the system unit

Set Up the Monitor

Warning: *It takes two people to lift the monitor safely.*

1. Place the monitor on top of, or next to, the system unit.
 - If you have a VR299 color monitor, place it so the tilt-lock lever is on the right side of the monitor as you face the screen.
 - If you have a VR262 monochrome monitor and you have ordered the optional tilt-swivel stand, set the monitor on it according to the instructions that came with the stand.
 - The VR150 monochrome and VR160 and VR297 color monitors come with built-in tilt-swivel stands that do not lock into place and have no visible controls.
2. Be sure the on/off switch on the monitor is set to the off (0) position, as shown in Figure 2-12.

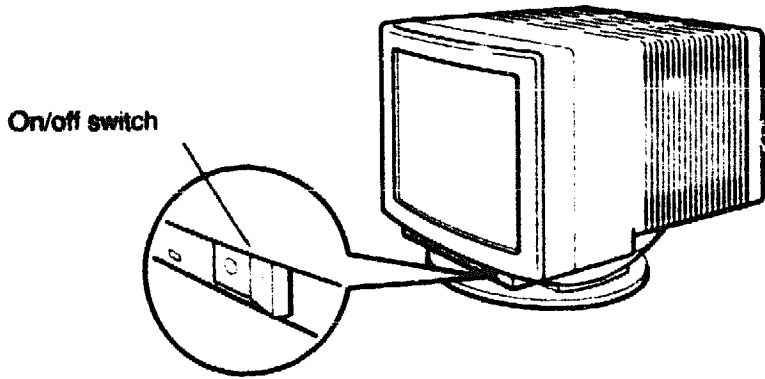

VR297 monitor

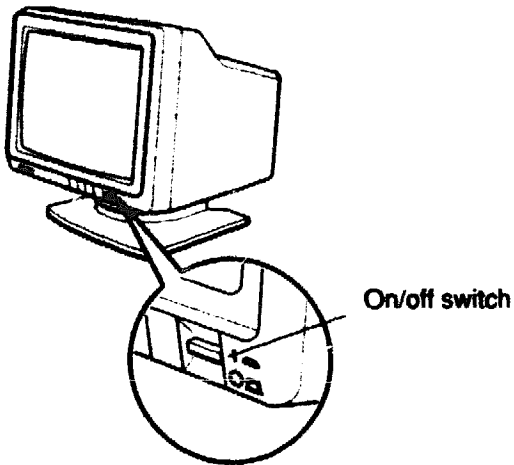

VR150 monochrome monitor

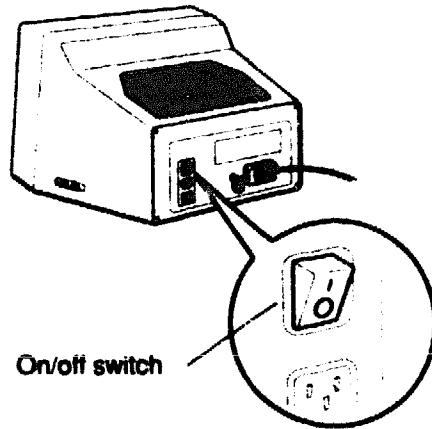

VR262 monochrome monitor

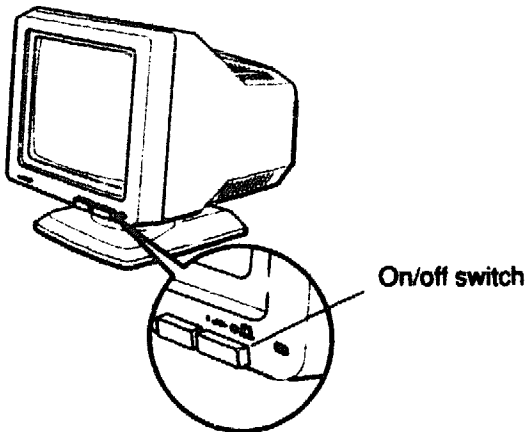

VR160 color monitor

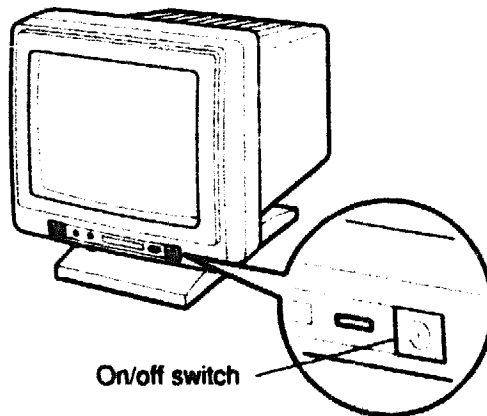

VR299 color monitor

DEP1004

Figure 2-12. The on/off switch on the monitor

Connect the Video Cable to the Monitor

The video cable for a monochrome monitor has one round connector on its free end. The video cable for a color monitor has three round connectors on its free end.

- To connect a video cable to a monochrome monitor, follow the instructions below.
- To connect a video cable to a color monitor, turn to page 2-17.

To Connect a Video Cable to a Monochrome Monitor

1. Firmly push the round connector on the free end of the video cable onto its connector on the monitor and twist it to the right until it slides forward and locks into place.

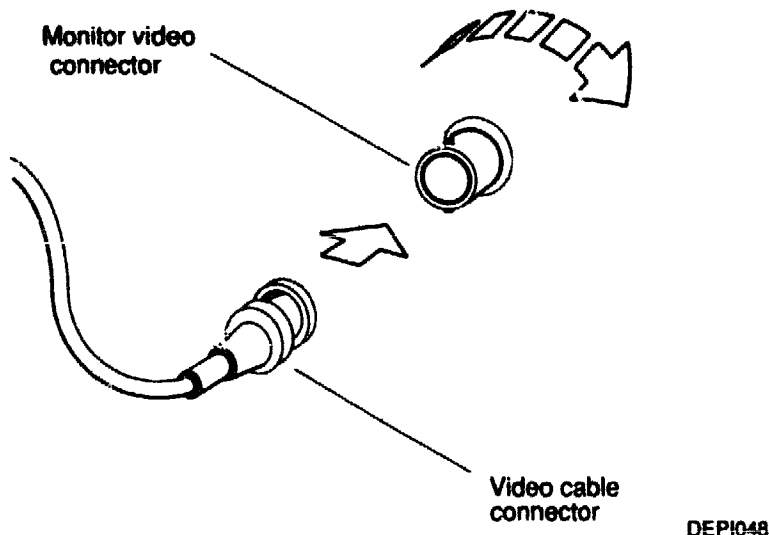
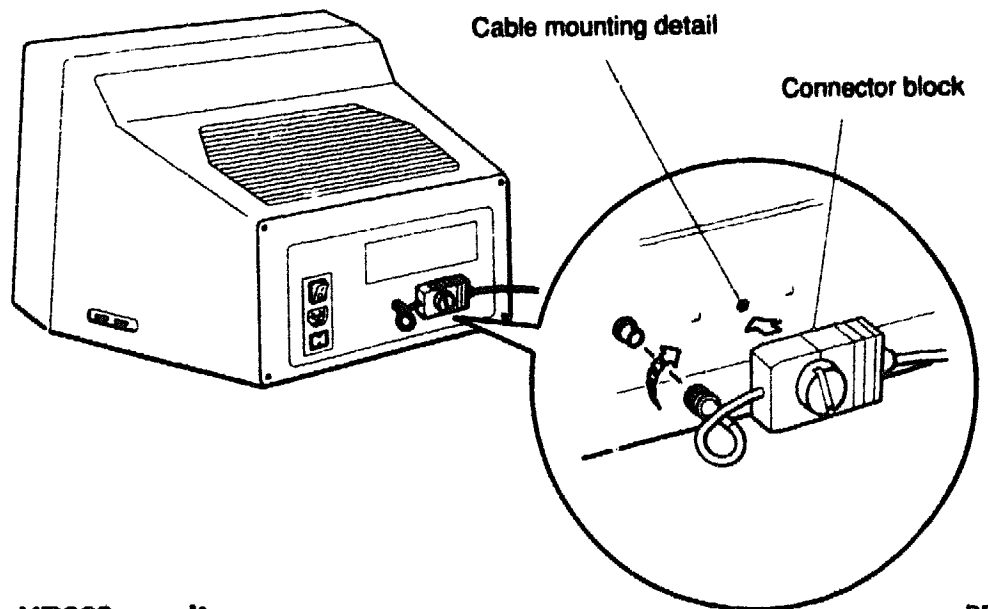
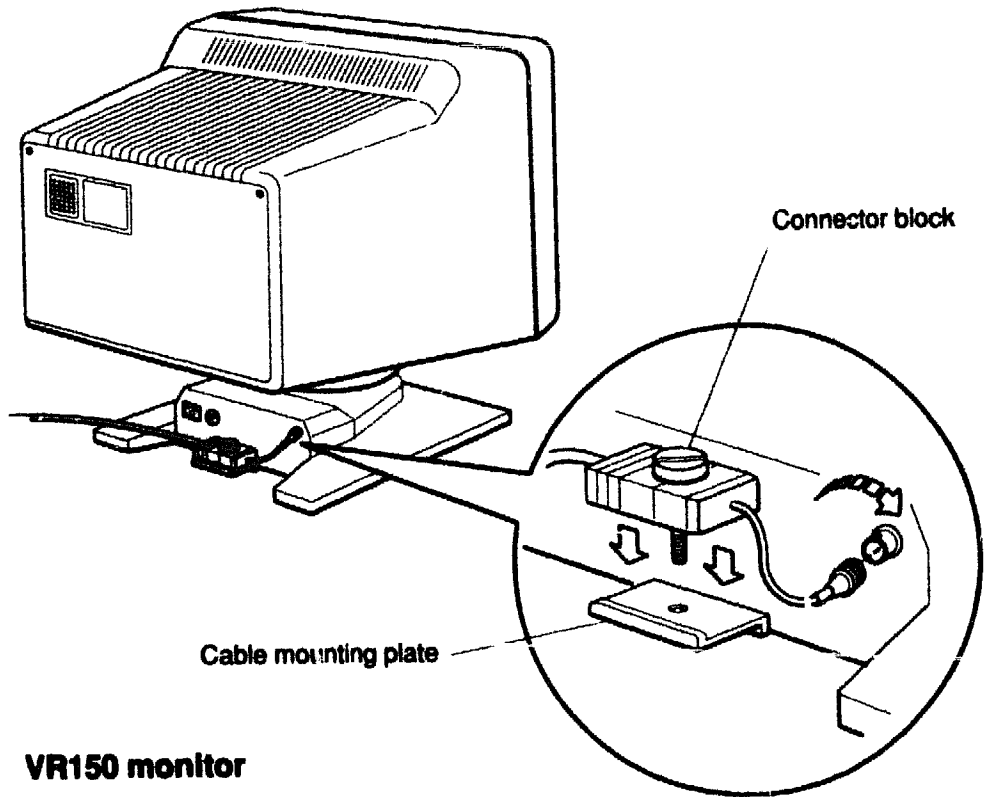

Figure 2-13. Connecting a video cable connector

2. Place the cable's connector block on the cable mounting plate or against the mounting detail on the monitor, as shown in Figure 2-14.
3. Find the knob with the short screw on it.
4. Insert the screw on the knob into the hole on the connector block and turn the knob to the right to tighten it.



DEPI006

Figure 2-14. Connecting a video cable to a VR150 or VR262 monochrome monitor

To Connect a Video Cable to a Color Monitor

The free end of the video cable has a set of red, green, and blue (RGB) signal cables. These three cables connect with the three connectors on the back of the monitor in the following order, from left to right: red, green, blue.

1. Firmly push each cable connector onto its connector on the monitor and twist it to the right until it slides forward and locks into place.

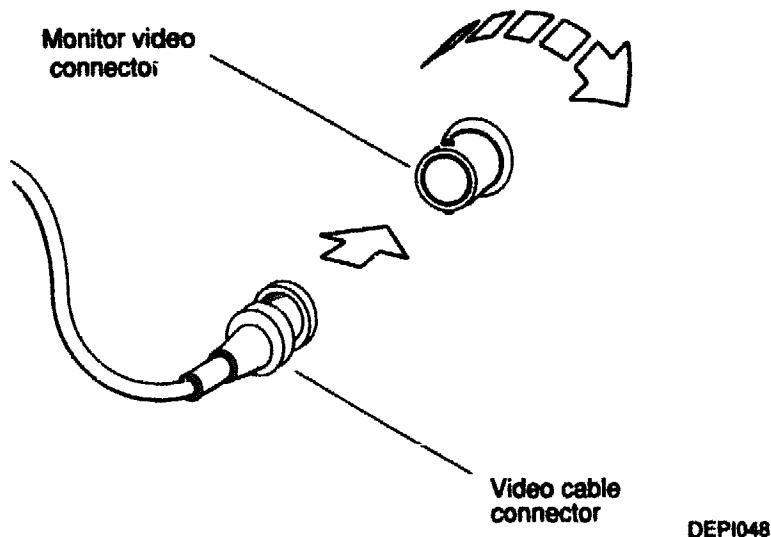
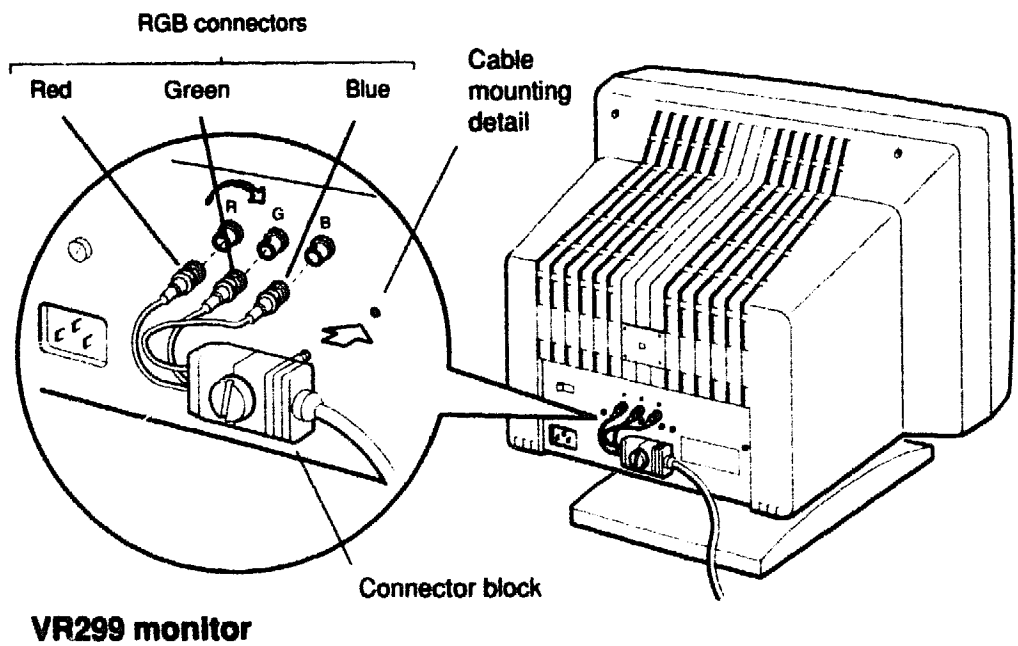
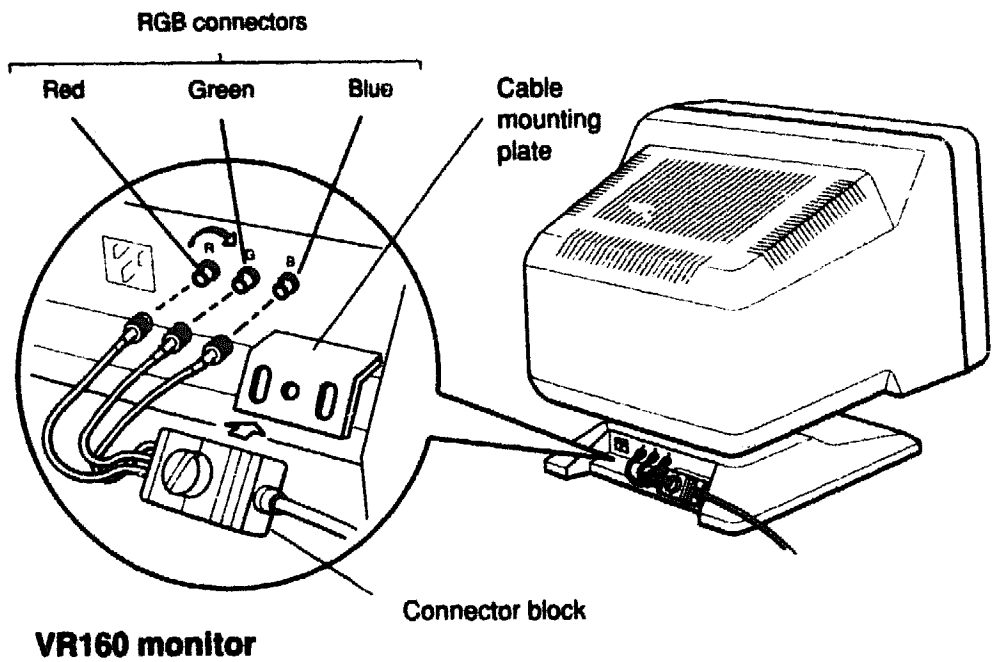

Figure 2-15. Connecting a video cable connector

2. Place the cable's connector block on the cable mounting plate or against the cable mounting detail on the monitor, as shown in Figure 2-16.

If you have a VR297 monitor, the video cable that came with your monitor does not have a cable block or knobs. These are not needed.

3. Insert the screw on the knob into the hole on the connector block and turn the knob to the right to tighten it.
 - For the VR160 color monitor, use the knob with the short screw.
 - For the VR299 color monitor, use the knob with the long screw.



DEPI007

Figure 2-16. Connecting a video cable to a VR160 or VR299 color monitor

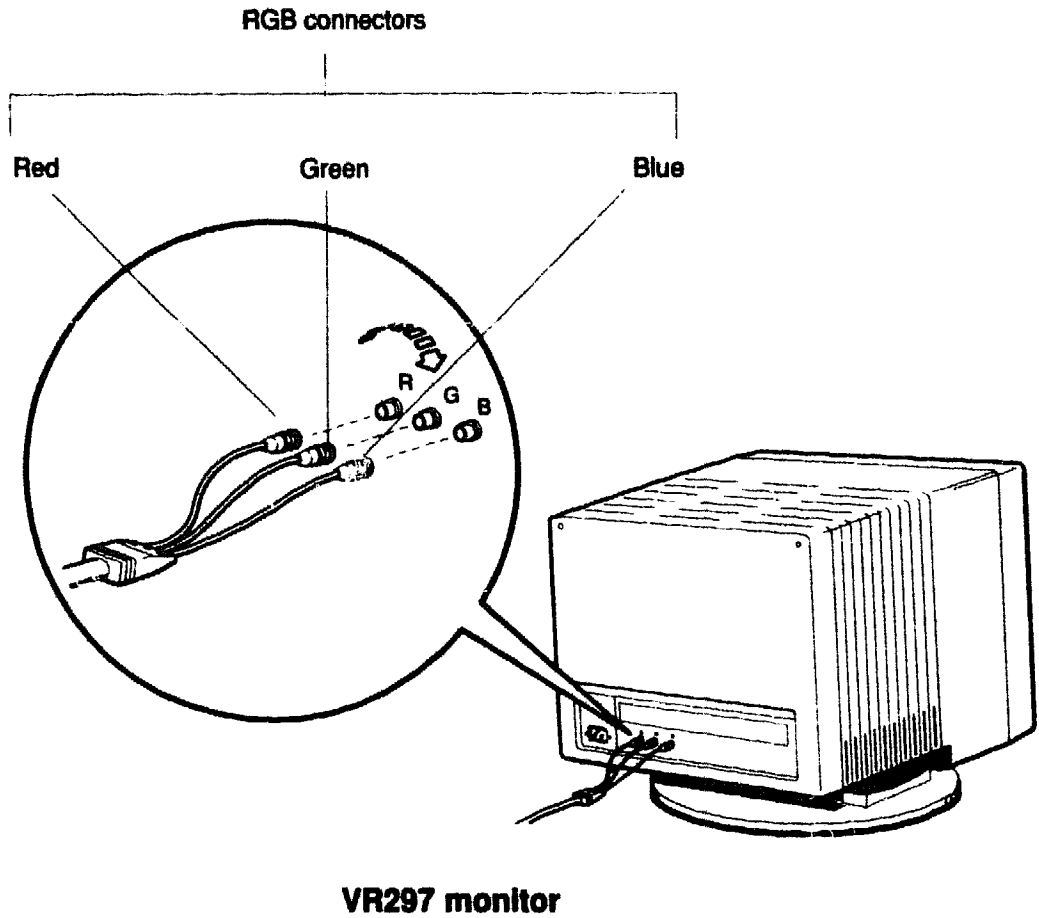

DEPI082

Figure 2-17. Connecting a video cable to a VR297 monitor

Connect the Power Cable and Power Cord

With your shipment, you received a monitor-system unit power cable that allows power to flow from the power source through the system unit and to the monitor. You use this cable instead of the power cord that came in your monitor carton.

Power cords for optional devices come with those devices. After you have connected the system unit power cord and the power cable, set up your optional devices and connect their power cords according to the instructions that came with them.

The voltage for many devices, including most monitors, must match that of your power source. It is either 110/120 or 220/240 volts. Where necessary, a yellow voltage label that covers the power connector tells you what you have.

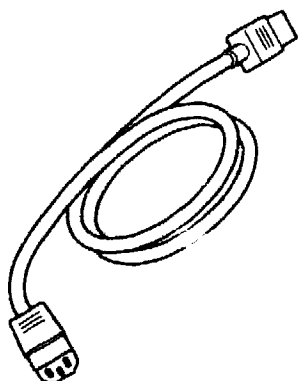

Monitor-system unit power cable

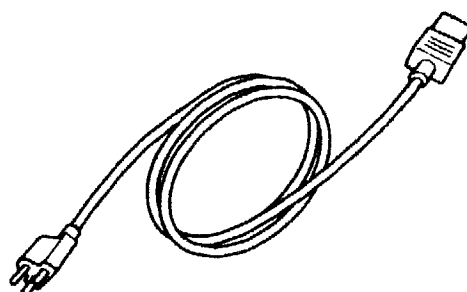

System unit power cord

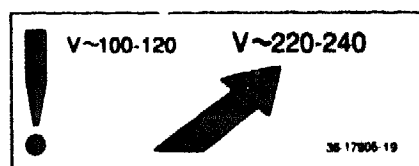
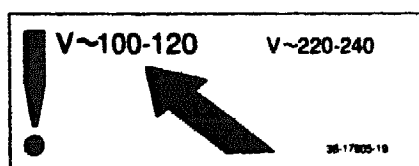

Voltage labels

DEPI016

Figure 2-18. Power cable, power cord, and voltage labels

To Connect the Monitor-System Unit Power Cable

Caution: Connecting the monitor to a system unit that receives its power from a source that does not meet the voltage requirements of the monitor can damage the monitor.

1. Read and remove any yellow voltage label or factory-installed software label that covers the power connector on the back of the monitor.
2. Plug the prongless end of the power cable into the power connector on the monitor.
3. Plug the pronged end of the cable into the power outlet on the back of the system unit.

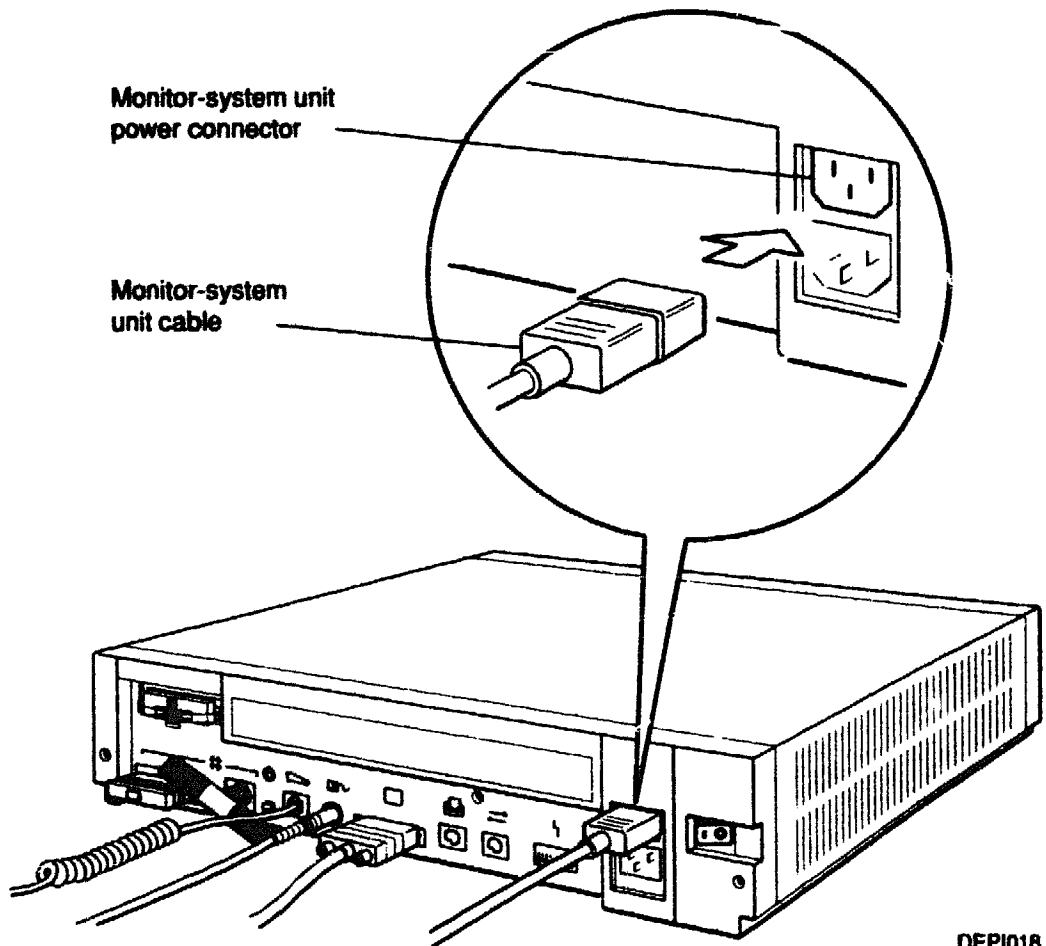

DEPI018

Figure 2-19. Connecting a power cable to a system unit power outlet

To Connect the System Unit Power Cord

1. Plug the prongless end of the power cord into the power connector on the back of the system unit.
2. Plug the pronged end of the cord into the power source.

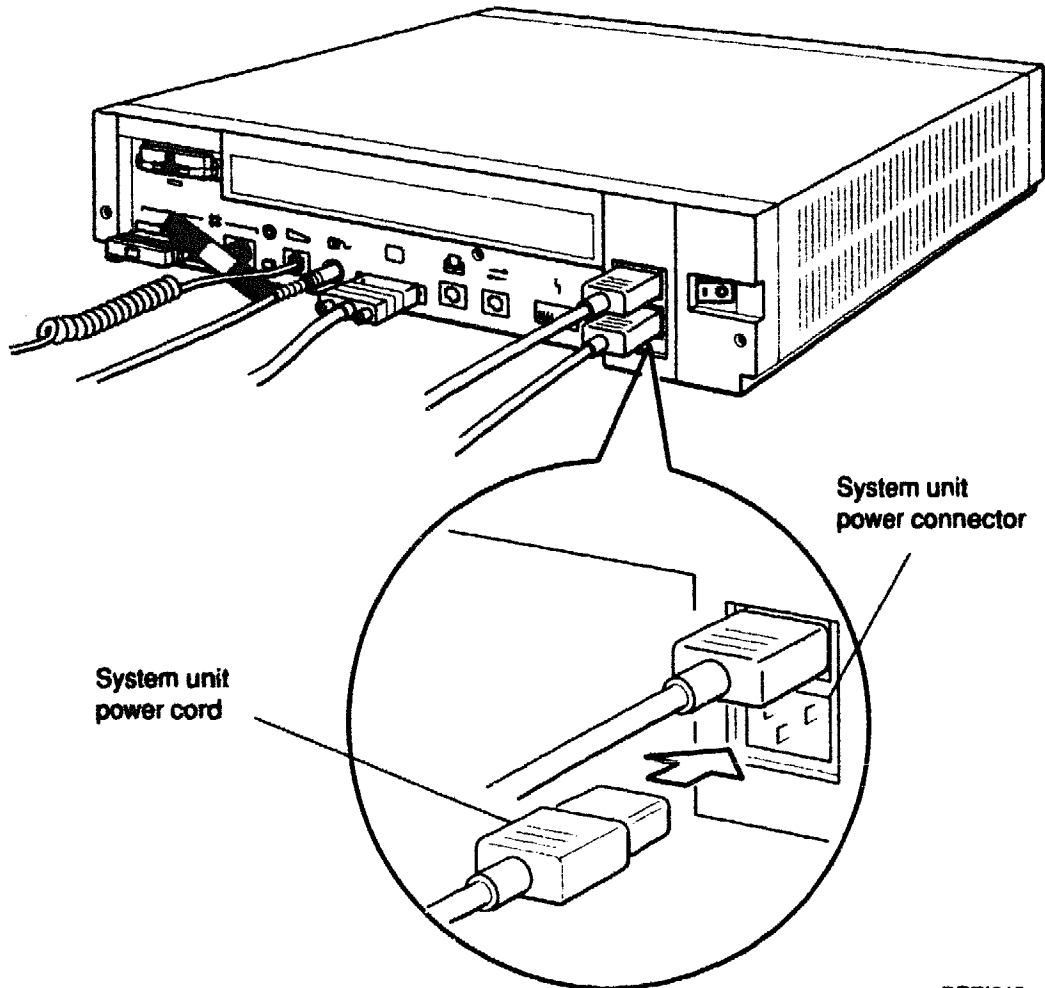

Figure 2-20. Connecting the system unit power cord

DEPI019

Starting and Testing the Workstation

This chapter tells you

- **How to turn on your monitor and system unit**
- **How the power-up self-test operates and how to use the results**
- **How to get your workstation connected to a network**

Turn On the Monitor

The procedure for turning on the monitor varies according to the monitor. In all cases, a green light glows on the front of the monitor and a display appears on the screen after you turn on the system unit.

1. Find the brightness and contrast controls located by their icons on the monitor.
2. Turn both controls all the way on.



Contrast icon

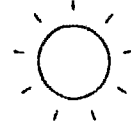

Brightness icon

DEP1052

Figure 3-1. Contrast and brightness icons

To Turn On a VR150 Monochrome Monitor

Set the on/off switch on the front of the monitor to the on (in) position by pressing it until it locks into place.

The indicator light glows green and the display appears after you turn on your system unit.

To Turn On a VR262 Monochrome Monitor

Set the on/off switch on the back of the monitor to the on (1) position by pressing the 1 on the switch.

The indicator light glows green and the display appears after you turn on your system unit.

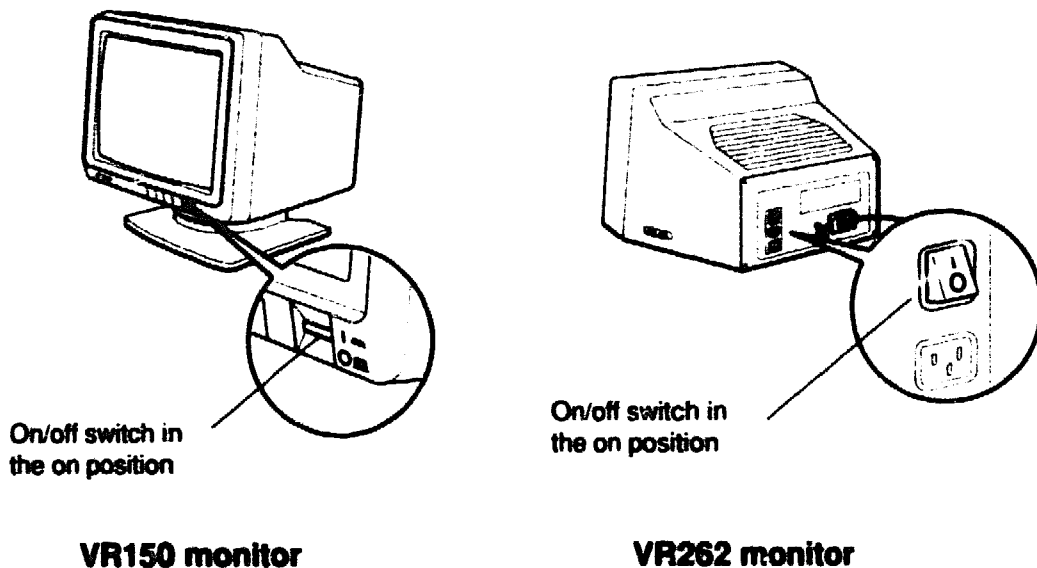

DEP1020

Figure 3-2. Turning on monochrome monitors

To Turn On a VR160 Color Monitor

Set the on/off switch on the front of the monitor to the on (in) position by pressing it until it locks into place.

The indicator light glows green and the display appears after you turn on your system unit.

To Turn On a VR297 Color Monitor

Set the on/off switch on the front of the monitor to the on (1) position by pressing the 1 on the switch.

The indicator light glows green and the display appears after you turn on your system unit.

To Turn On a VR299 Color Monitor

Set the on/off switch on the front of the monitor to the on (1) position by pressing the 1 on the switch.

The indicator light glows green and the display appears after you turn on your system unit.

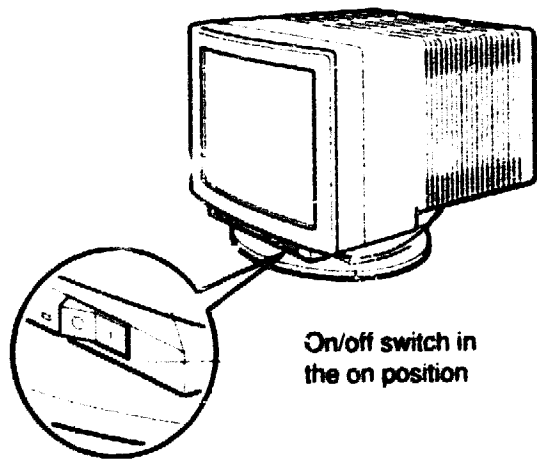

On/off switch in the on position

VR297 monitor

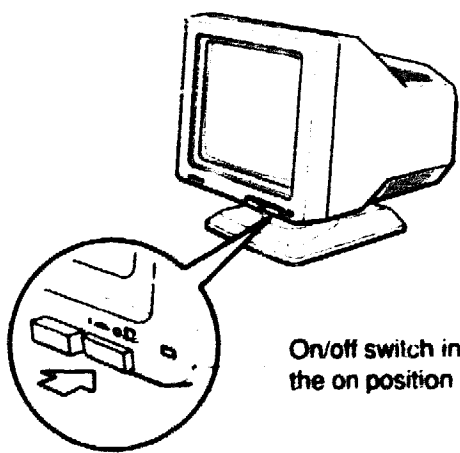

On/off switch in the on position

VR160 monitor

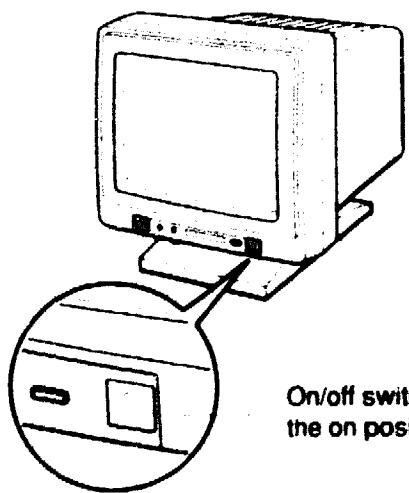

On/off switch in the on position

VR299 monitor

DEP1021

Figure 3-3. Turning on color monitors

Turn On the System Unit

Caution: To avoid damaging equipment that has been moved inside from a cold environment, let it warm to room temperature before turning it on.

Set the on/off switch on the back of the system unit to the on (1) position by pressing the 1 on the switch.

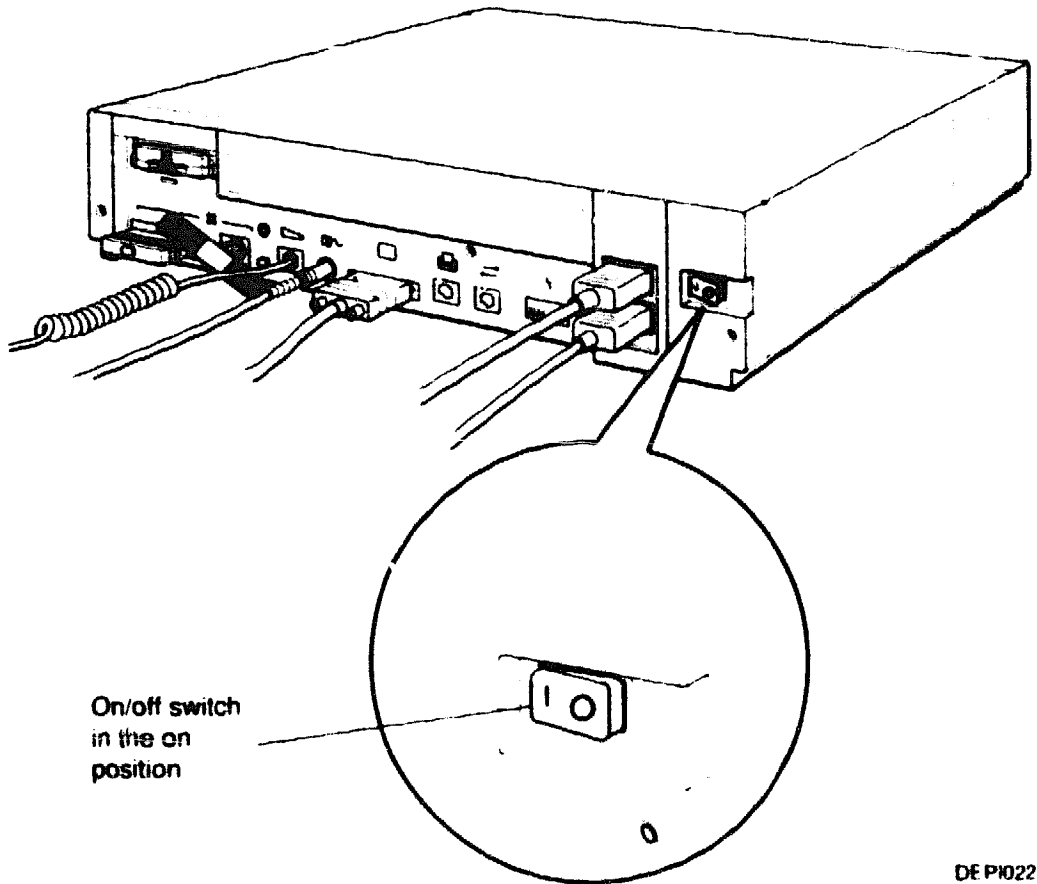

DE P1022

Figure 3-4. Turning on the system unit

When the system unit turns on, the following things happen:

- **The system unit begins its power-up self-test.**
- **The power indicator light on the front of the system unit glows green.**
- **The power-up self-test messages gradually appear at the bottom of the monitor screen.**
 1. **Turn down the brightness until the screen just becomes dark.**
 2. **Adjust the contrast until the display on the screen is comfortable for you to read.**

If Your System Fails to Turn On

If nothing happens when you turn on the system unit, check to be sure that

- **All power cords are connected properly**
- **There is power at the power outlet**
- **Monitor and system unit power switches are set to the on position**

If the system still fails to work, contact your system manager or your Digital service representative.

If Your Monitor Fails to Turn On

If the green light on the monitor turns on but the screen stays dark, be sure the contrast and brightness controls located by their icons on the monitor are turned all the way on.

If the screen remains dark, contact your system manager or your Digital service representative.

Check the Results of the Power-Up Self-Test

After you turn on your system unit and monitor, your workstation tests itself. This process takes about a minute. The numbers that identify the subtests that make up the self-test appear on your screen as your workstation runs them.

Because some subtests take longer than others, there are times when nothing happens on your screen. For example, the following display remains on your screen for several seconds:

```
KN01 V6.71
7..6..5..4..
```

During testing, a display similar to the following gradually appears on your screen:

```
KN01 V6.71
7..6..5..4..3..2..1..0
16Mb.....0
```

When testing has been completed successfully, a display similar to the following appears at the bottom of the screen:

```
KN01 V6.71
08-00-2b-0d-f7-6a
0x01000000
>
```

If a Subtest Is Unsuccessful

If your workstation fails a subtest, self-testing stops and the following message flashes on the screen:

```
FAILURE - RESET TO CONTINUE
```

The number of the subtest that failed is the last number displayed on your screen. In the following example, subtest 4 was unsuccessful.

```
KN01 V6.71
7..6..5..4..
FAILURE - RESET TO CONTINUE
```

If subtest 7, 6, 5, or 4 fails

Record the number of the failed subtest and report it to your system manager or your Digital service representative.

If test 3 fails

1. Turn off the system unit and check the connections for your keyboard and mouse.

Be sure to inspect the connectors on the system unit and the cable connectors for damaged pins.

2. Turn on the system unit to rerun the self-test.

If the subtest fails again, contact your system manager or your Digital service representative.

If subtest 2 fails

1. Turn off the system unit and be sure your ThickWire loopback connector and ThinWire Ethernet terminators are connected properly.

Inspect the ThickWire loopback connector and the ThickWire connector on the system unit for damaged pins.

2. Turn on the system unit to rerun the self-test.

If the subtest fails again, contact your system manager or your Digital service representative.

If subtest 1 fails

1. Turn off the system unit and be sure your SCSI terminator is securely connected.

Inspect the SCSI connector on the system unit and the connector on the terminator for damaged pins.

2. Turn on the system unit to rerun the self-test.

If the subtest fails again, contact your system manager or your Digital service representative.

Arrange for Your Ethernet Connection

If your workstation will be connected to a network, you need to find your Ethernet station address and report it to your system manager. Then ask your system manager to connect you to the network.

To Find Your Ethernet Station Address

Type `test -c` at the console prompt. A display similar to the following should appear on the screen. The third line of the display is your Ethernet station address.

```
MEM: 16Mbytes
VIDEO: MONO
ETHERNET STA ADDR: 08-00-2b-0d-f7-6a
SCSI DEVS:
U[7]
U[6] KN01--SII
U[5]
U[4]
U[3] Dev typ 0 RZ
      RMB 0x0
      Vrs 1
      Format 1 CCS
      Add len 31
      Vndr DEC
      PID RZ23 (C) DEC
      Frevl vl 0618
U[2]
U[1]
U[0]
>>
```

Installing Optional Peripheral Devices

This chapter tells you how to install the optional peripheral devices for your workstation.

External optional devices include up to four small computer system interface (SCSI) storage devices, a printer, and a modem. SCSI storage devices include floppy disk, compact disc, tape, and hard disk drives.

Warning: *Turning on power before you are instructed to do so can cause injury and damage equipment.*

Installing External Storage Devices

The types of external storage devices available for your DECstation 2100/3100 workstation include the following:

- 332-megabyte RZ55 hard disk drive
- 95-megabyte TK50Z tape drive
- 1.2-gigabyte TLZ04 cassette tape drive
- 635-megabyte RRD40 optical compact disc drive
- 2.2-gigabyte TKZ08 8-mm tape drive

These storage devices come preinstalled in expansion boxes.

You can connect as many as four expansion boxes to your system.

The first box connects directly to the system unit. Each additional box connects to the box connected before it.

The BA42 storage expansion box is also available. This expansion box houses up to two storage devices. Drives available in the BA42 storage expansion box include the following:

- 332-megabyte RZ55 hard disk drive
- 655-megabyte RZ56 hard disk drive
- 1.0-gigabyte RZ57 hard disk drive
- 95-megabyte TZ30 tape drive
- 1.44-megabyte RX23 diskette drive
- 1.2-megabyte RX33 diskette drive
- 525-megabyte TZK10 QIC tape drive

For more information on the BA42 storage expansion box and its drives, refer to the *BA42 Storage Expansion Box Installation Guide*.

For information on the TKZ08 tape drive, see the owner's manual that came with that drive.

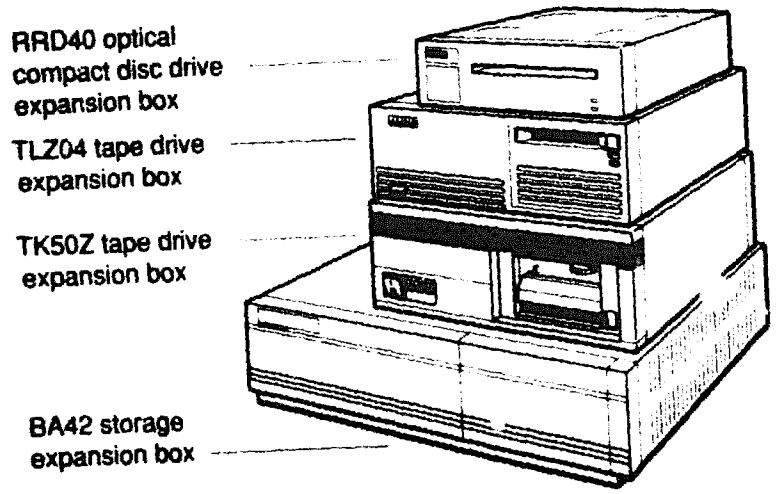

WSE2O017

Figure 4-1. Expansion boxes

To Connect Expansion Boxes

To connect expansion boxes to your system unit, find the following items:

- One system unit-expansion box cable with a different connector at each end

You use this cable for only the first box you install. If you have more than one of these cables, set the others aside.

- One 18-inch-long expansion box cable with identical connectors at each end if you are connecting more than one box

Caution: Using cables other than the Digital-supplied 18-inch cable between expansion boxes and the Digital-supplied system-unit expansion box connector cable can cause the boxes to malfunction.

- One expansion box terminator
- One expansion box power cord

Other items may have been supplied and should be used where appropriate. See the documentation that came with your drives for information on their use.

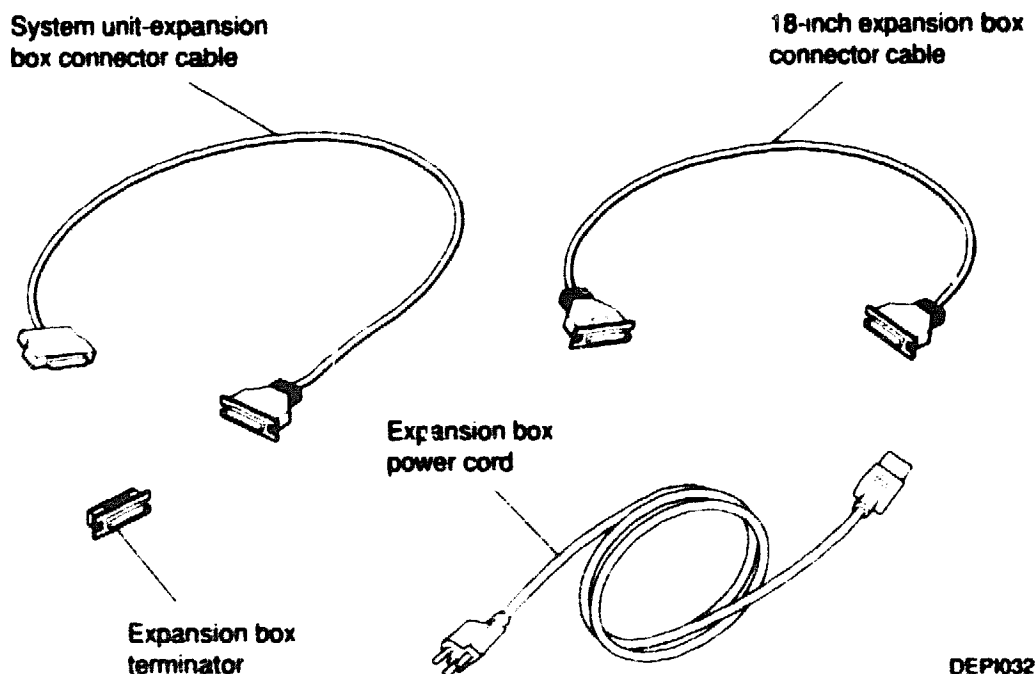

DEP1032

Figure 4-2. Expansion box cables, cord, and terminator

1. Turn off the system unit and any expansion boxes.
 - If you receive your power from a power strip, turn off the power strip.
 - If you have only one expansion box and do not use a power strip, turn off the expansion box by pressing the 0 on the on/off switch on a hard disk drive, tape drive, or optical compact disc drive, or by pressing and releasing the on/off switch on a cassette tape drive. Then turn off the system unit.
2. Remove the terminator from the SCSI connector on the back of the system unit, as shown in Figure 4-3.

Be sure to save the terminator.

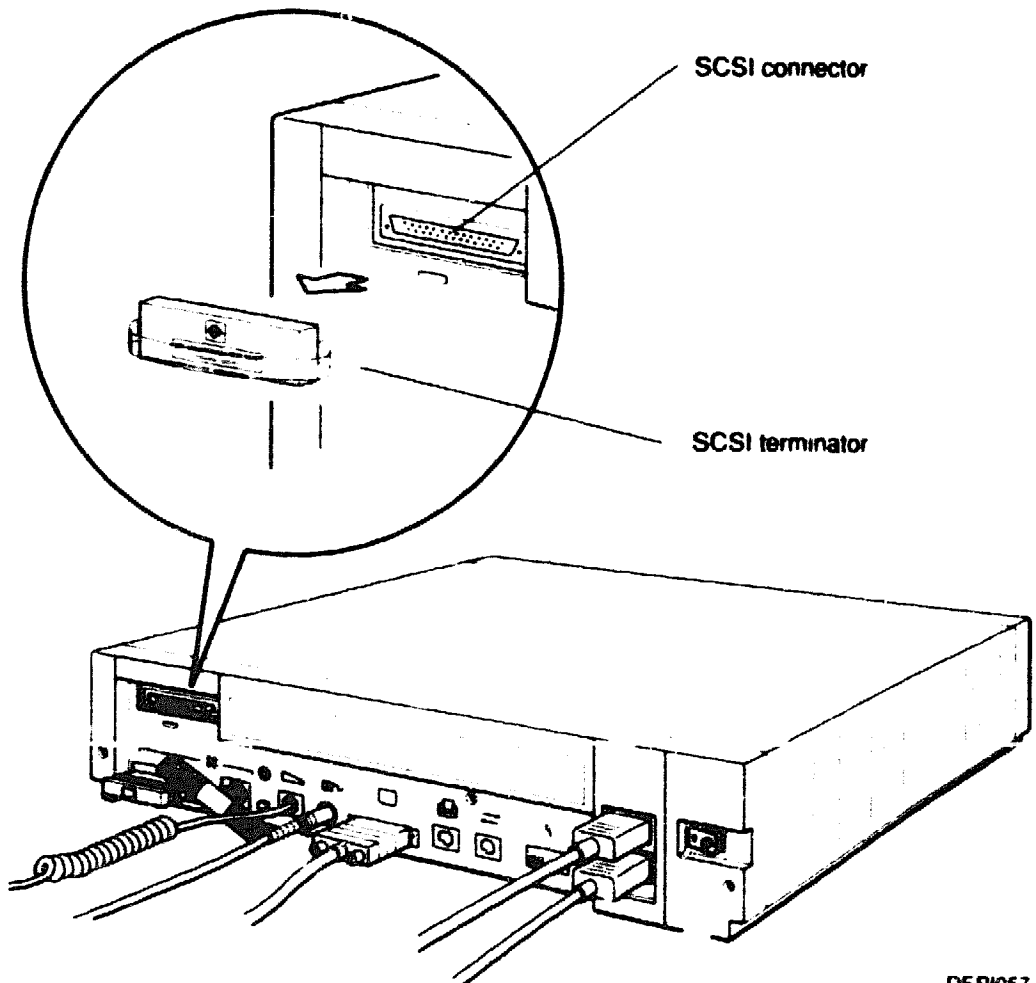

DEP1057

Figure 4-3. Removing the SCSI terminator

3. If you have only one box, or if this is the first box you are connecting, be sure the SCSI switches on the back of the box are set correctly.

See the *BA42 Storage Expansion Box Installation Guide* for information on how to set SCSI switches on drives in the BA42 expansion box.

- If your first box is a TK50Z tape drive (you can see TK SCSI on the label by the switches), the settings are

Down Up Down

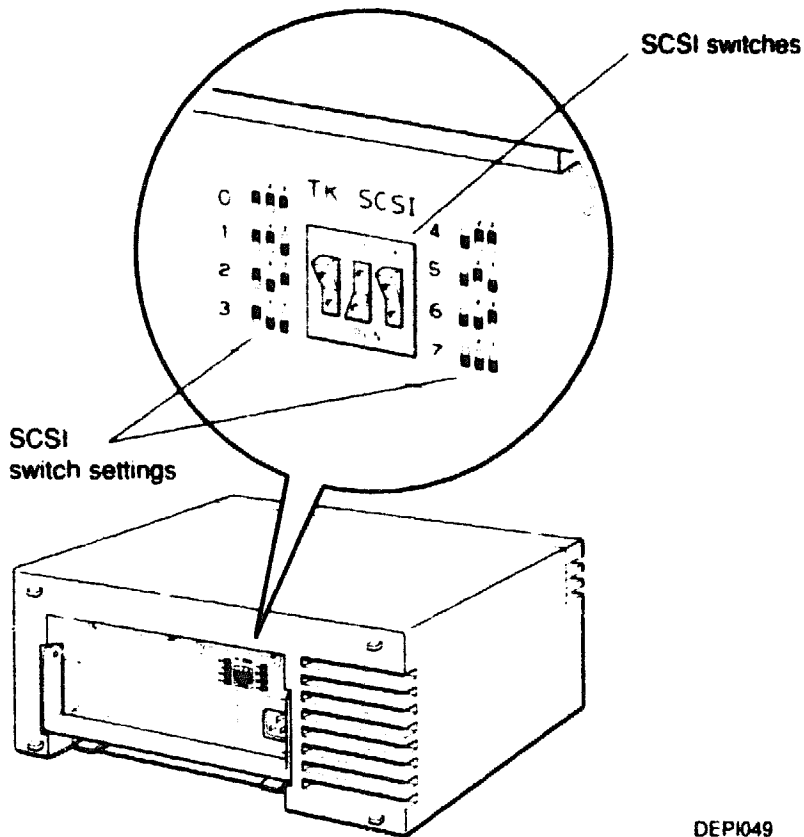
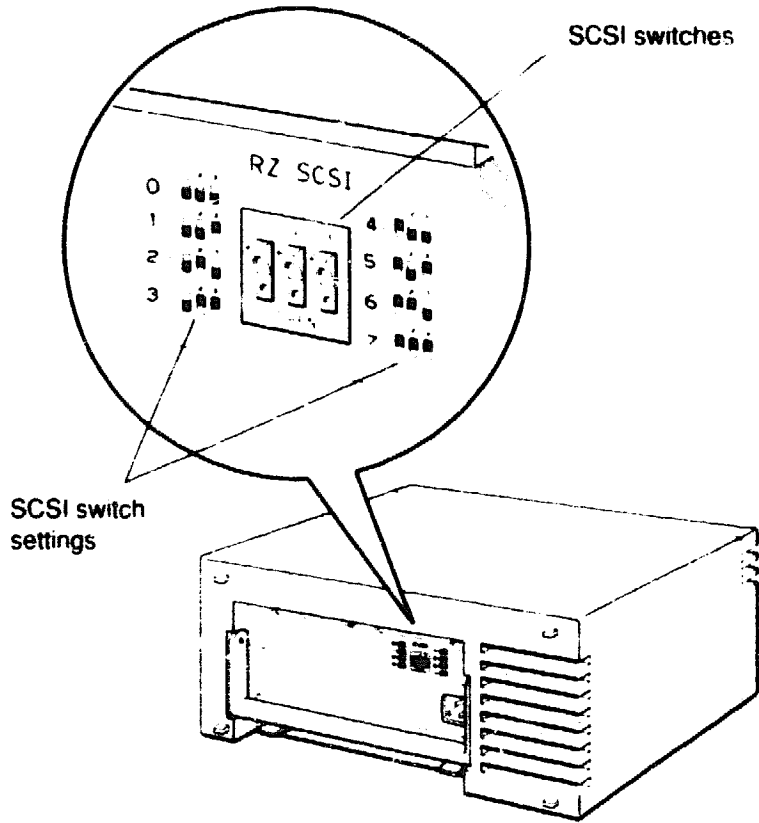

Figure 4-4. ID switch setting for the TK50Z tape drive

- If your first box is an RZ55 hard disk drive in its own expansion box (you can see RZ SCSI on the label by the switches), the settings are

Down Down Down



DEPI039

Figure 4-5. ID switch setting for the RZ55 hard disk drive

- If your first box is a TLZ04 cassette tape drive (the word **OPTIONS** appears above the switch numbers), the settings are

Up Down Up Down

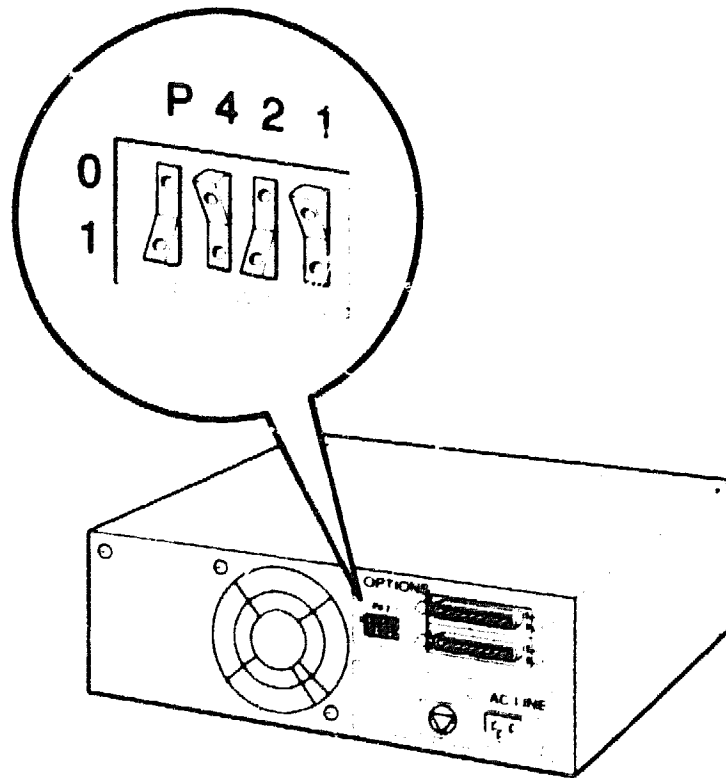

DEPI076

Figure 4-6. ID switch setting for the TLZ04 cassette tape drive

- If your first box is an RRD40 optical compact disc drive (there is no label by the switches), the settings are

Up Down Down Down

If you are installing more than one expansion box, always connect the optical compact disc drive last.

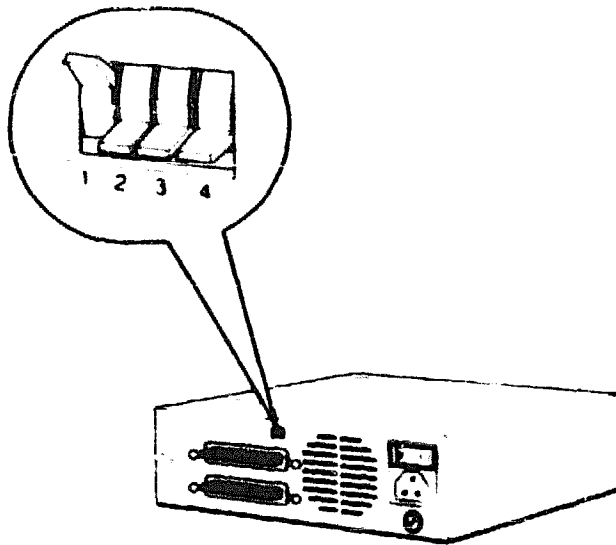

DEFM081

Figure 4-7. ID switch setting for the RRD40 optical compact disc drive

4. Position the smallest of the two connectors on your system unit-expansion box cable so the widest part of the connector aligns with the widest part of the connector on the system unit.
5. Push the cable connector into the SCSI connector on the back of the system unit.

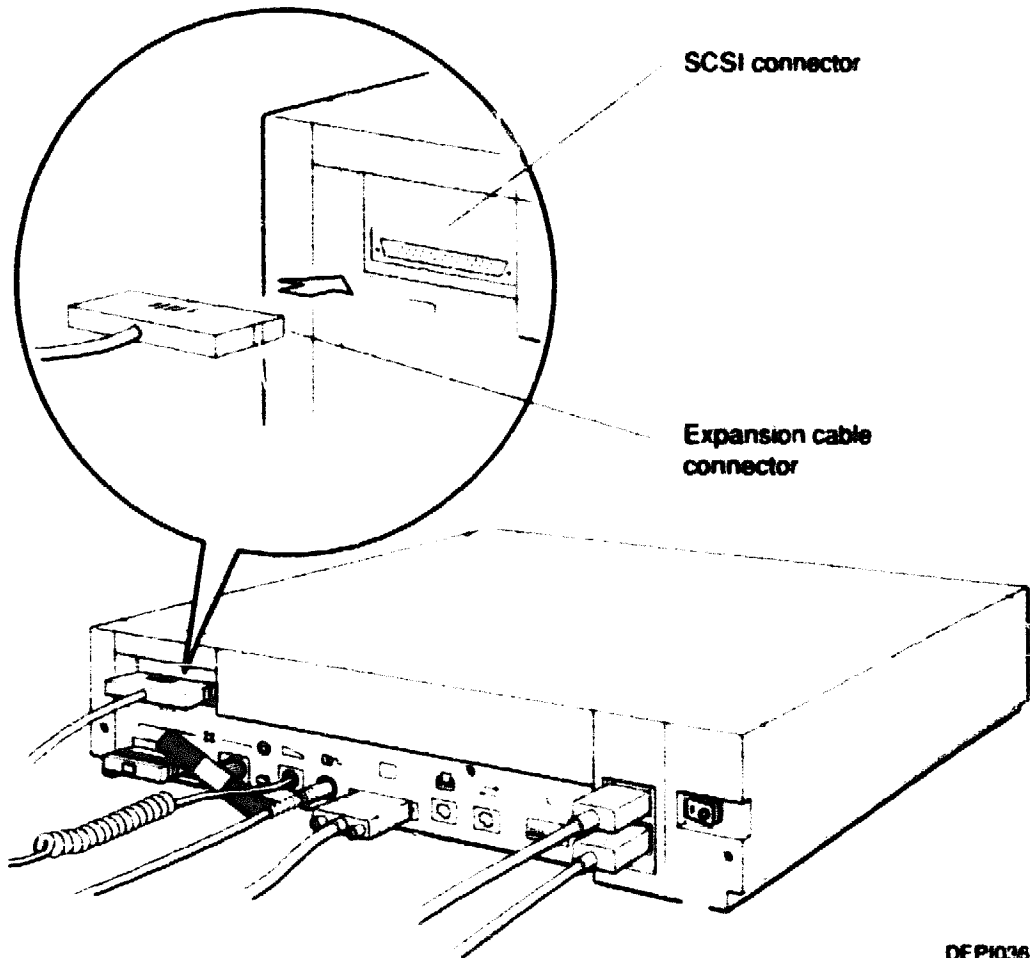

DEP1036

Figure 4-8. Attaching a system unit-expansion box cable to the SCSI connector on the system unit

- 6. Attach the free end of the system unit-expansion box cable to one of the connectors on the back of the expansion box.**
 - a. Press the two wire brackets on the expansion box connector away from the connector.**

If you are using a hard disk drive or a tape drive, slide the cable connector up between the expansion box and its handle.
 - b. Position the cable connector so its widest part aligns with the widest part of the expansion box connector.**
 - c. Push the cable connector into the expansion box connector as far as it will go.**
 - d. Press the two wire brackets firmly against the sides of the connector until they click into the grooves on the connector.**

If you are attaching more than one expansion box, turn to page 4-15.

Be sure the wire brackets
are locked into the grooves
on the sides of the connector.

System unit-expansion box
cable connector

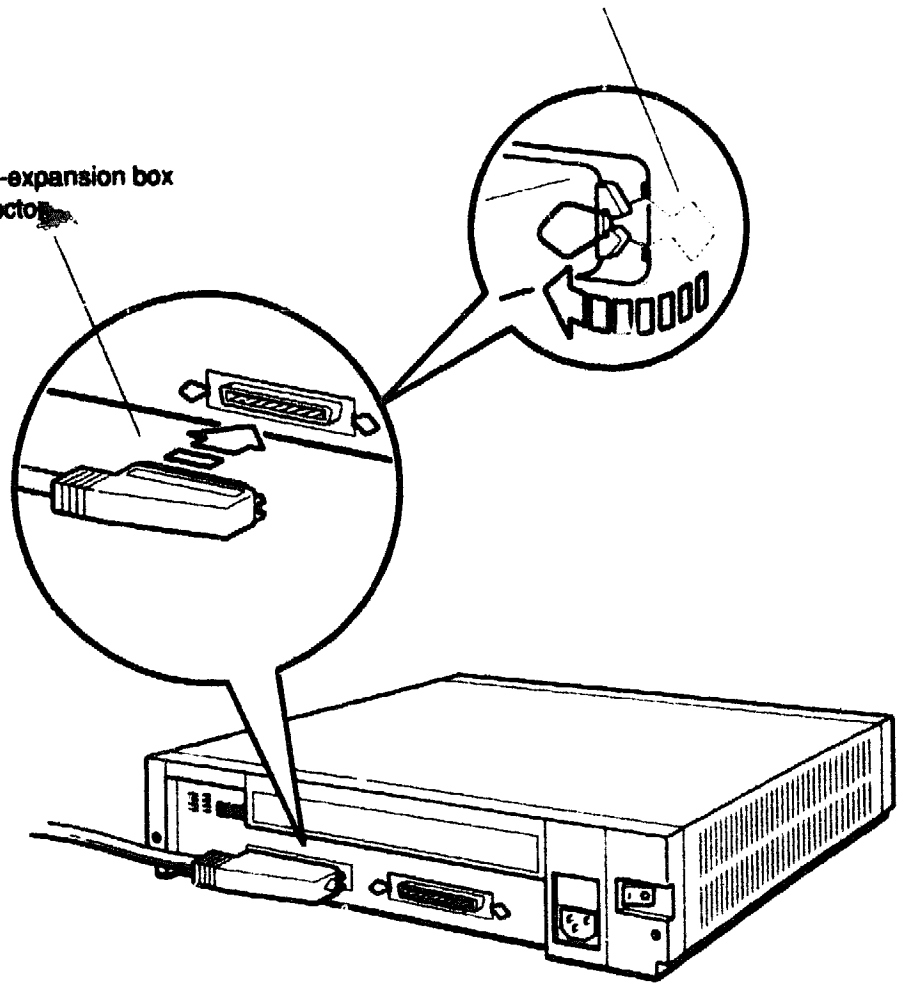

DEP1081

Figure 4-9. Attaching a system unit-expansion box cable to the SCSI connector on an expansion box

To Attach Only One Box

1. Attach the terminator that came with your expansion box to the empty connector on the box.
 - a. Press the two wire brackets on the empty connector away from the connector.
 - b. Position the terminator so the widest part of its connector aligns with the widest part of the connector on the box.
 - c. Push the terminator into the expansion box connector as far as it will go.
 - d. Press the two wire brackets firmly against the sides of the terminator until they click into the grooves on the terminator.

Be sure the wire brackets are locked into the grooves on the sides of the connectors.

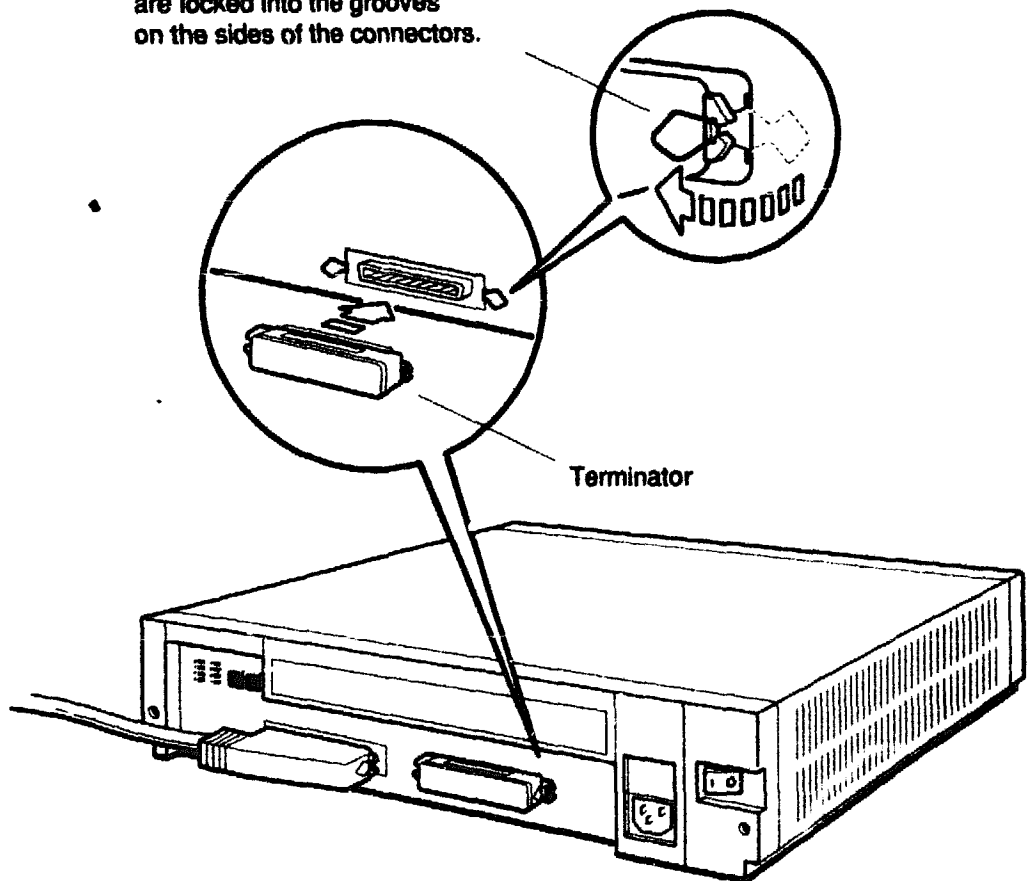

DEPI077

Figure 4-10. Terminating an expansion box

2. Plug the prongless end of the power cord into the power connector on your expansion box.
3. Plug the pronged end of the cord into the same power source as the one used by your system unit.

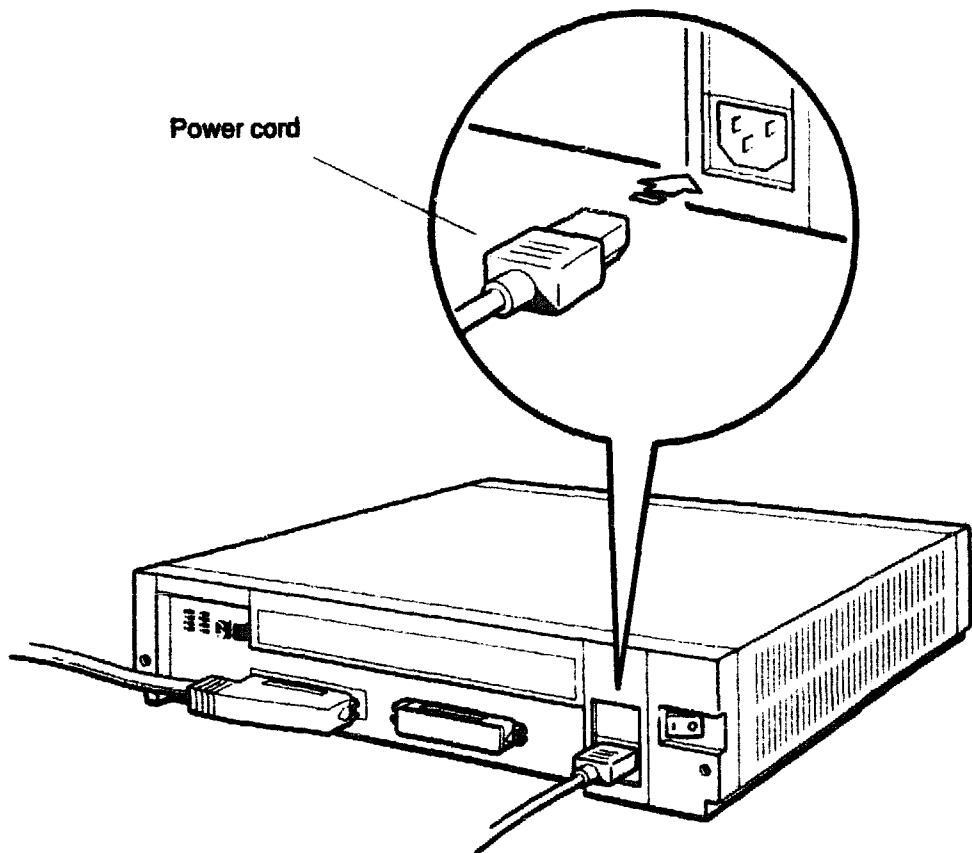

DEPI078

Figure 4-11. Connecting an expansion box power cord

4. Turn on the expansion box by pressing the 1 on the on/off switch on a hard disk drive, tape drive, or optical compact disc drive or by pressing and releasing the on/off switch on a cassette tape drive.

5. Turn on the system unit by pressing the 1 on the on/off switch on the back of the unit.

Your system runs through its self-tests and displays the console prompt (>>) when all the tests are completed successfully.

If a subtest fails,

- a. Turn off your expansion box and system unit.
- b. Check your expansion box connections. Be sure to inspect your connectors for damaged pins.
- c. Turn on the expansion box and system unit again.

If the subtest still fails, contact your Digital service representative.

6. Type **test -c** at the console prompt (>>) and check the configuration display to be sure the system recognizes the device.

To Attach More Than One Box

Before you connect any boxes after the first, stack them together, and set the SCSI switches for each box.

To know how to set your SCSI switches, you need to display your configuration table. This table tells you what storage devices your system has and where your storage devices are located.

Reading the configuration table

Type **test -c** at the console prompt (>>) and press Return to display your configuration table.

A display similar to that in Figure 4-12 should appear on your screen. The section following the display describes the display in detail.

```

MEM: 16Mbytes
VIDEO: MONO
ETHERNET STA ADDR: 08-00-2b-0d-f7-6a
SCSI DEVS:
U[7]
U[6]KN01--SII
U[5]
U[4]
U[3] Dev typ 0 RZ
      RMB 0x0
      Vrs 1
      Format 1 CCS
      Add len 31
      Vndr DEC
      PID RZ23 (C) DEC
      Frevlvl 0618
U[2]
U[1]
U[0]
>>

```

Figure 4-12. Sample configuration display

From the configuration display, you learn the following:

Line 1 — Tells you how much memory you have. The system described in the figure has 16 megabytes of memory. You could add one or two 4-megabyte memory modules to this system.

Line 2 — Tells you what kind of monitor you have. The system described in Figure 4-12 has a monochrome monitor. If it had a color monitor, this line would read COLOR.

Line 3 — Tells you your Ethernet station address. The address for the system described in the figure is 08-00-2b-0d-f7-6a. You need to know your Ethernet address if you want to be able to connect your workstation to a network.

Line 4 — Introduces the list of storage-device locations available in your system. These storage devices are called small computer system interface (SCSI) devices. The remaining lines of this display describe any SCSI devices assigned to units 7 through 0.

Line 5 — Tells you that the system described in the figure has nothing assigned to unit 7. Leave this unit empty. Assigning a storage device to unit 7 can cause the system to malfunction.

Line 6 — Tells you that unit 6 contains the controller that directs the operation of your SCSI devices.

Lines 7, 8 — Tell you that the system described in the figure has nothing assigned to units 5 and 4. You could add storage devices here.

Line 9 — The system in the figure has a hard disk drive assigned to unit 3. The words `Device type 0 DISK` appear on the unit-number line for any unit that contains a hard disk drive or a diskette drive. If unit 3 contained a tape drive or a cassette tape drive, the words `Device type 1 TAPE` would appear on the unit-number line. If unit 3 contained an optical compact disc drive, the words `Device type 5 ROM DISK` would appear on the unit-number line.

Lines 10–16 — Describe the device assigned to unit 3 in more detail. This type of description is displayed for any SCSI device connected to your system. In this display, line 15 in column 2 reads `RZ23` for an internal RZ23 hard disk drive.

Lines 17, 18, 19 — The system described in the figure has no devices assigned to units 2, 1, and 0. You could add storage devices here.

Setting the SCSI switches

Now that you know where you can add your storage devices, you can set your SCSI switches.

See the *BA42 Storage Expansion Box Installation Guide* for information on how to set SCSI switches on drives in the BA42 expansion box.

- If you have a TK50Z tape drive it should be your first box. Set its switches

Down Up Down

- If you have no tape drive and your first box is a RZ55 hard disk drive in its own expansion box, the settings for that box are

Down Down Down

- If you have no tape drive and your first box is a TLZ04 cassette tape drive, the settings for that box are

Up Down Up Down

- If you have no tape drive and your first box is an RRD40 optical compact disc drive, the settings for that box are

Up Down Down Down

Set the SCSI ID switches on the back of your expansion boxes according to Table 4-1.

Table 4-1. SCSI ID Switch Settings

Location	RX Diskette Drive or TK Tape Drive or TLZ Cassette Tape Drive ¹	RZ Hard Disk or RRD40 Compact Disc ²
Unit 7	Not available	Not available
Unit 6	Not available	Not available
Unit 5	Down Up Down	Up Down Up
Unit 4	Down Up Up	Up Down Down
Unit 3	Up Down Down	Down Up Up
Unit 2	Up Down Up	Down Up Down
Unit 1	Up Up Down	Down Down Up
Unit 0	Up Up Up	Down Down Down

¹Switch 1 (the left switch) on the cassette tape drive should always be in the up position. ID switch settings for this drive start with switch 2.

²Because switch 4 on the optical compact disc is not used, its position has no effect on the ID number.

Connecting boxes

Caution: *Using cables other than the Digital-supplied 18-inch cable between expansion boxes can cause the boxes to malfunction.*

1. Plug one end of the 18-inch expansion box cable into the free connector on the back of the first expansion box.
If your expansion box is a disk or tape drive, slide the free end of the cable up between the next expansion box and its handle.
2. Plug the free end of the cable into one of the connectors on the next box, as shown in Figure 4-13.

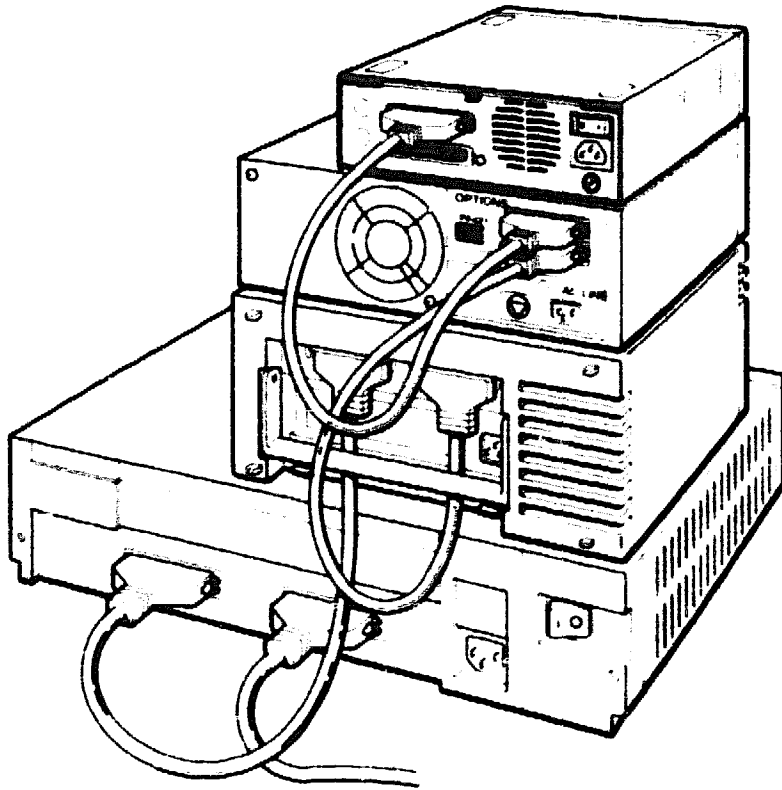

RRD40 optical
compact disc drive
expansion box

TLZ04 tape drive
expansion box

TK50Z tape drive
expansion box

BA42 storage
expansion box

WSE21049

Figure 4-13. Connecting an expansion box to another expansion box

- 3. Repeat steps 1 and 2 for each additional box.**
- 4. Attach the terminator that came with your expansion boxes to the empty connector on your final box, as shown in Figure 4-14.**
 - a. Press the two wire brackets on the empty connector away from the connector.**
 - b. Position the terminator so the widest part of its connector aligns with the widest part of the connector on the box.**
 - c. Push the terminator into the expansion box connector as far as it will go.**
 - d. Press the two wire brackets firmly against the sides of the terminator until they click into the grooves on the terminator.**

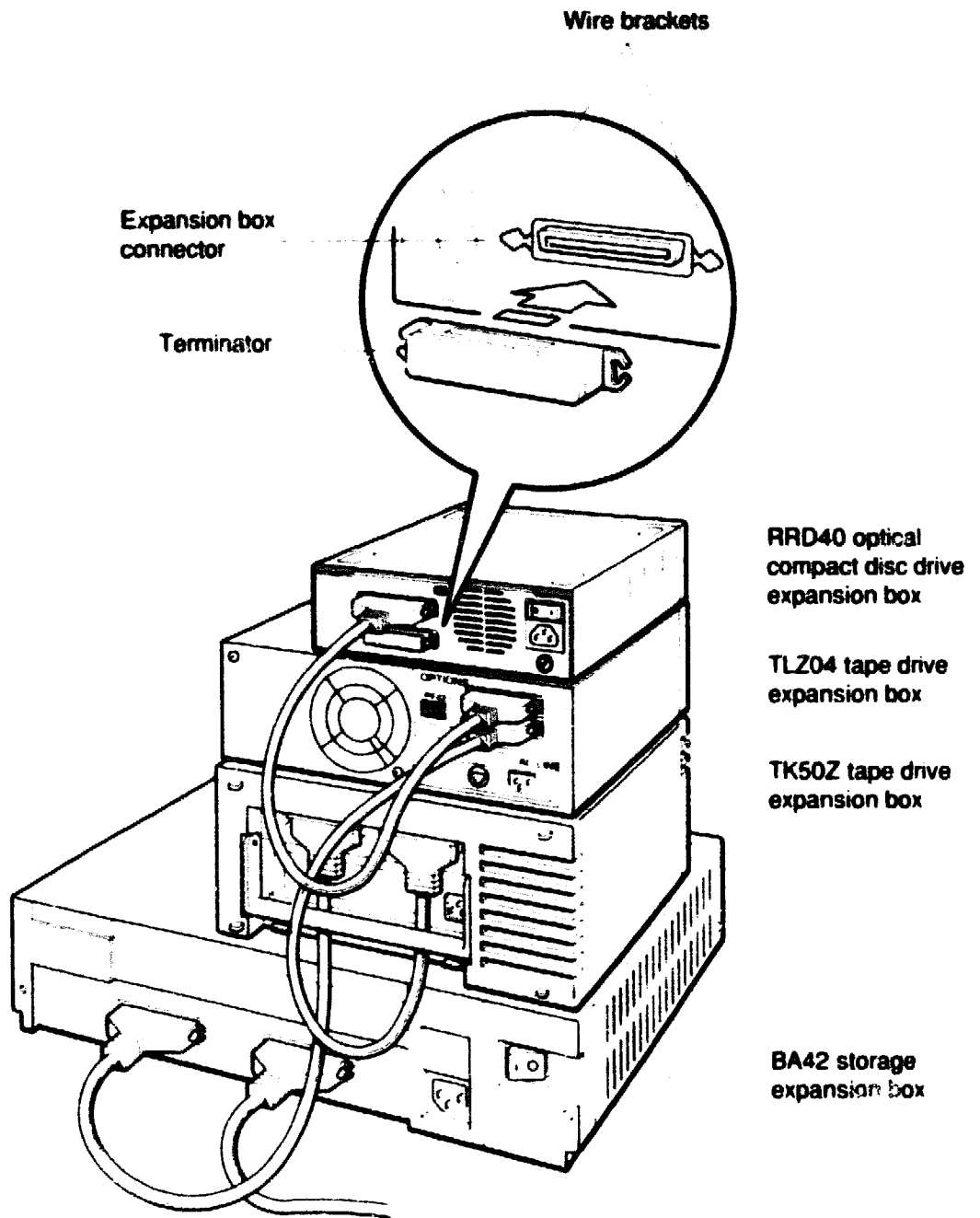

DEP1079

Figure 4-14. Terminating the final expansion box

5. Plug the prongless end of the power cord into the power connector on each expansion box.

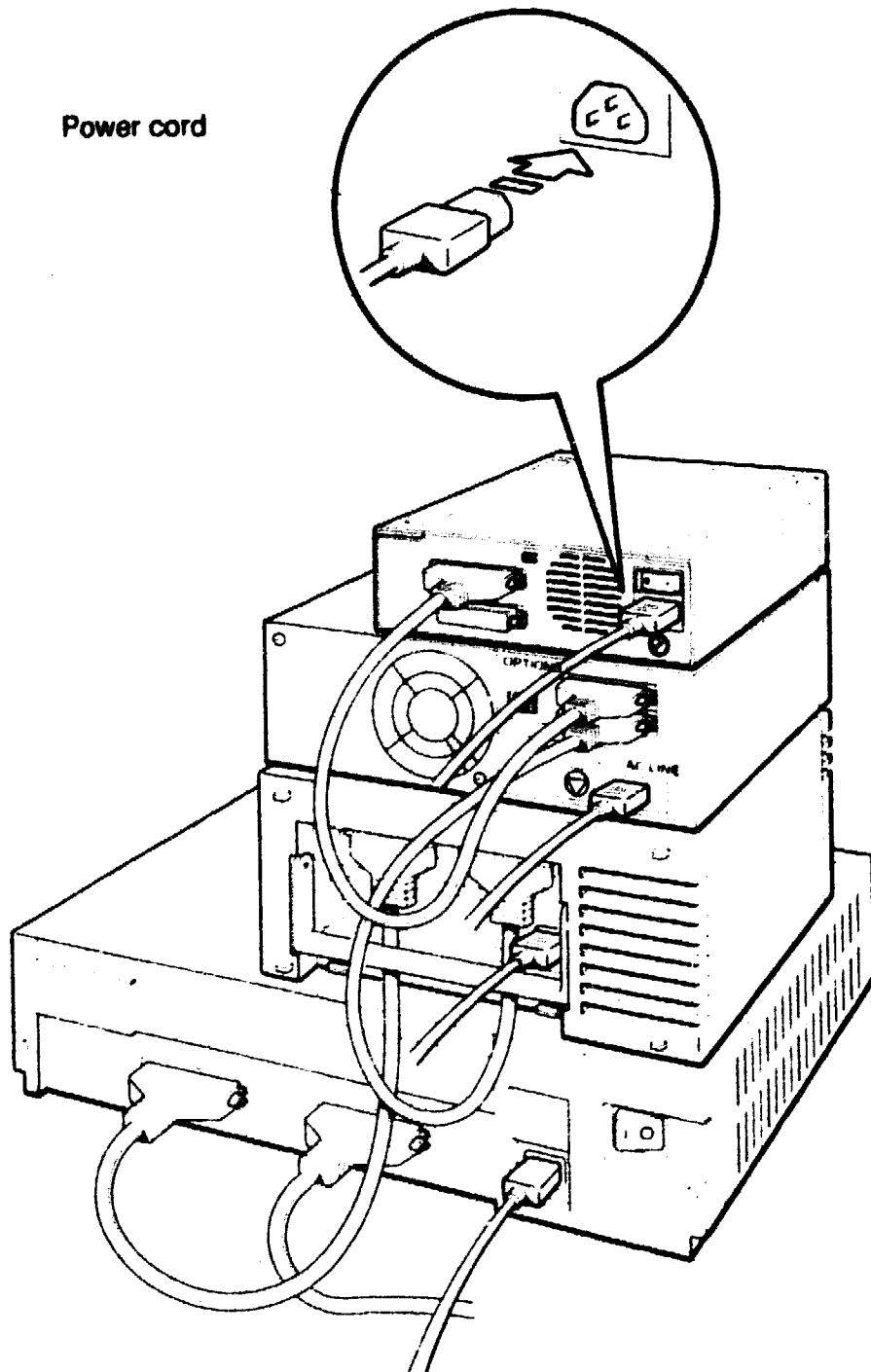

DEPI080

Figure 4-15. Connecting the power cord

6. Plug the pronged end of the cord into the power source.

Because you are installing more than one box, the power source for your system unit and expansion boxes should be one common power strip.

7. Be sure the voltage-selection switch on your optical compact disc drive is set for the same voltage as that of your power source.

Caution: Connecting an expansion box to a power source that does not meet the voltage requirements of the box can damage the device inside that box.

8. Turn on each expansion box by pressing the 1 on the on/off switch on the box.

After this first time, turn your expansion boxes on and off by using the on/off switch on your power strip.

9. Turn on the system unit by pressing the 1 on the on/off switch on the back of the unit.

After this, turn your system unit on and off by using the on/off switch on your power strip.

Your system performs its self-test and displays the console prompt (>>) when all the subtests are completed successfully.

If a subtest fails,

- a. Turn off your system by using the on/off switch on your power strip.
- b. Check your expansion box connections. Be sure to inspect your connectors for damaged pins.
- c. Use the on/off switch on your power strip to turn your system on again.

If the subtest still fails, contact your Digital service representative.

10. Type **test -c** at the console prompt (>>) and check your configuration display to be sure your system recognizes each device.

Installing a Printer

When you ordered your printer, you may also have ordered a serial line cable. If you have one, you connect one end of this cable to your printer cable and the other end to your system unit.

- 1. Find your serial line cable if one came with your shipment.**
- 2. Follow the instructions that came with your printer to perform these tasks:**
 - Be sure the printer is turned off.**
 - Set up the printer and attach the cable that came with it.**
 - Set the proper baud rate and control settings.**
- 3. Turn off the system unit by pressing the 0 on the on/off switch on the back of the system unit or, if you have a power strip, by turning off the power strip.**
- 4. If you have a serial line cable, attach one end of it to the free end of the printer cable.**
- 5. Position the connector on your printer cable, or on the free end of the serial line cable, so the clip is down.**
- 6. Push the cable connector into the connector under the printer icon on the back of the system unit, as shown on Figure 4-16.**

The connector clicks into place.

- 7. Plug the power cord into the power source.**
- 8. Turn on the printer.**
- 9. Turn on the system unit by pressing the 1 on the on/off switch or by turning on the power strip.**

Your system performs its self-test and displays the console prompt (>>) when all the subtests are completed successfully.

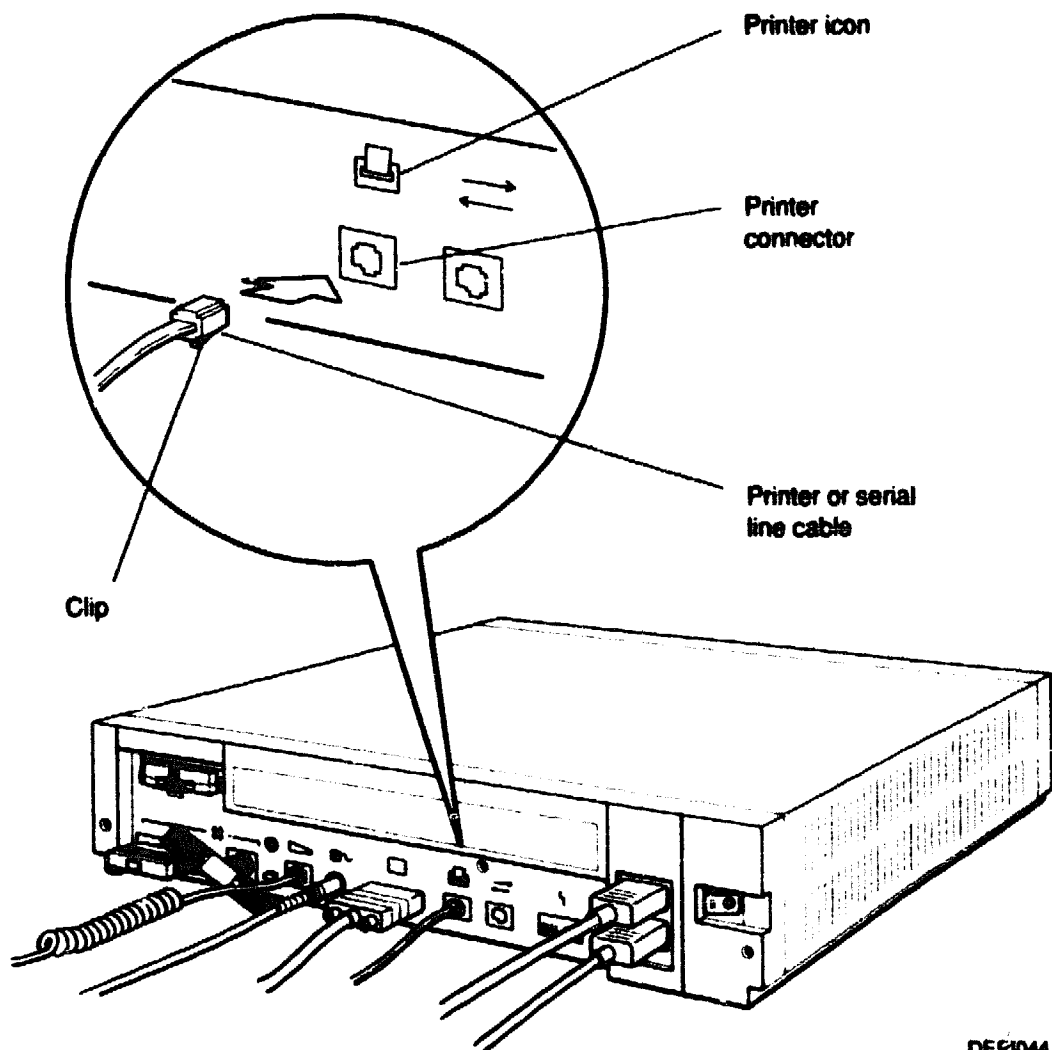

DEF1044

Figure 4-16. Connecting a printer to the system unit

If a subtest fails,

- a. Turn off your printer and system unit.
- b. Check your printer connections.
- c. Turn your printer and system unit on again.

If the subtest still fails, contact your Digital service representative.

See the documentation that came with your operating system for instructions on setting the correct baud rate in the DECstation 2100/3100 environment variables.

Installing a Communications Device

When you ordered your communications device, you may also have ordered a serial line cable with which to connect the device to your system unit.

1. If you ordered one, find the serial line cable that came with your shipment.
2. Follow the instructions that came with your device to perform these tasks:
 - Be sure the device is turned off.
 - Set up and attach the device to the cable that came with it.
 - Set the proper baud rate and control settings.
3. Turn off the system unit by pressing the 0 on the on/off switch on the back of the system unit or, if you have a power strip, by turning off the power strip.
4. If you have a serial line cable, attach one end of it to the free end of the device cable.
5. Position the connector on your device cable, or on the free end of your serial line cable, so the clip is down.
6. Push the cable connector into the connector under the communications icon on the back of the system unit as shown in Figure 4-17.
7. Plug the power cord into the power source.
8. Turn on the device by pressing the 1 on the on/off switch.
9. Turn on the system unit by pressing the 1 on the on/off switch or by turning on the power strip.

Your system performs its self-test and displays the console prompt (>>) when all the subtests are completed successfully.

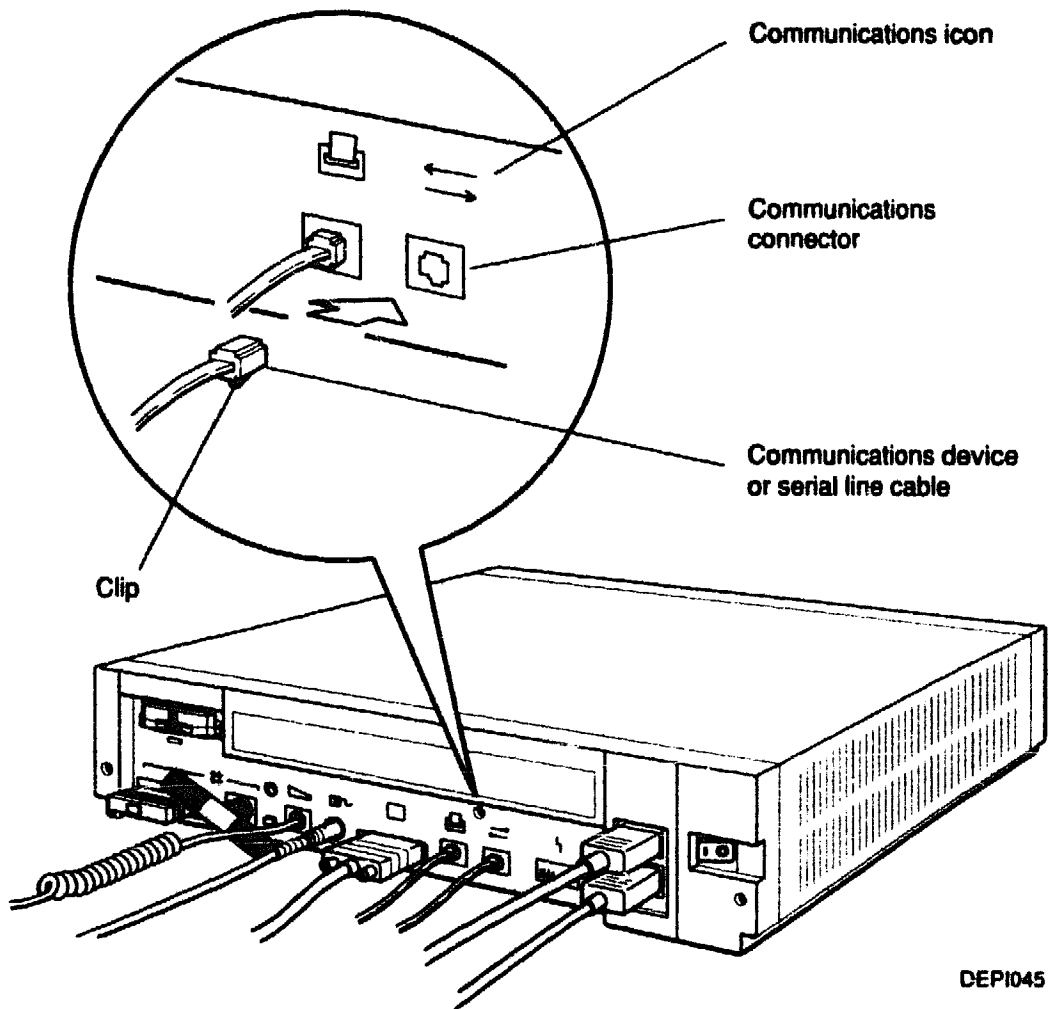

DEPI045

Figure 4-17. Connecting a communications device to the system unit

If a subtest fails,

- a. Turn off your device and system unit.
- b. Check your device connections.
- c. Turn your device and system unit on again.

If the subtest still fails, contact your Digital service representative.

See the documentation that came with your operating system for instructions on setting the correct baud rate in the DECstation 2100/3100 environment variables.

Completing the Hardware Installation

This chapter tells you

- How to gather the information you need to begin installing your worksystem software
- Where to learn how to install your applications software

Important: If line 1 of your power-up screen displays KN01 V6.5 or a lower version number, and any diagnostic command is issued, issue a hardware reset or an init command before attempting a boot or an auto command.

Using Ethernet to Access Your Worksystem Software

If you want to use Ethernet to access your worksystem software, make sure your system manager has your Ethernet station address to register you to do so. Ask your system manager for instructions on how to boot your worksystem software.

Installing Your Worksystem Software on a Hard Disk

To Use a Tape Drive

When using a tape drive to install an operating system on a hard disk, you need the following:

- A TK50Z or a TZ30 tape drive
- The ULTRIX TK50Z tape cartridge kit
- A hard disk drive

Your hard disk drive is formatted (ready to receive information) when you receive it from the factory.

In addition, you need to know

- The unit number of your tape drive
- How to use tape cartridges

See Chapter 4 of the *DECstation 2100/3100 Operator's Guide* or the documentation that came with your tape drive for instructions on using tape cartridges.

Finding the unit number of your tape drive

Type **test -c** at the console prompt (**>>**) and press Return.

A display similar to the one in Figure 5-1 appears on the screen.

```
MEM: 16Mbytes
VIDEO: MONO
ETHERNET STA ADDR: 08-00-2b-0d-f7-6a
SCSI DEVS:
U[7]
U[6]KN01--SII
U[5] Dev typ 1 TZ
          RMB          0xd0 rmv mda TZK50
          Vrs          1
          Format        0
          Add len      0
U[4]
U[3]
U[2]
U[1]
U[0]
>>
```

Figure 5-1. Sample configuration display

Line 4 of this display introduces the list of drives installed as part of your system.

- For hard disk drives or diskette drives, the following appears on the line that contains the unit number:

```
Dev typ 0 RZ
```

To determine whether the device is a hard disk or a diskette drive, look at the rightmost entry in the unit-number line.

- For tape drives or cassette tape drives, the following appears on the line that contains the unit number:

Dev typ 1 TZ

To determine whether the device is a tape drive or a cassette tape drive, look at the rightmost entry in the unit-number line.

In the sample display in Figure 5-1, you can see that unit 5 contains a tape drive.

To install your worksystem software, turn to “Where To Go from Here” later in this chapter.

To Use Ethernet

When using Ethernet to install an operating system on a hard disk, you need the following:

- A connection to Ethernet
- A hard disk drive

Your hard disk drive is formatted (ready to receive information) when you receive it from the factory.

Ask your system manager to tell you when the remote installation service on the Ethernet server is ready so you can install your operating system.

Where To Go from Here

If You Have Factory-Installed Software

Important: *Your worksystem contains factory-installed software if the power connector on your system unit is covered with a yellow label that reads*

Attention: If this system contains a hard disk with preinstalled software, see installation guide before booting system.

For startup instructions for factory-installed software, see *Start-up Instructions for Factory-Installed Software on DECstations 2100/3100* after you have installed your workstation hardware.

Caution: *Use the start-up instructions guide before booting your system. Failure to do so could damage the software.*

Be sure to back up your software as soon as your system is running. Refer to the *Guide to SCAMP for Workstations* for information on backing up your system.

To Perform a Basic Worksystem Software Installation

If your worksystem does not contain factory-installed software,

1. Read the release notes.
2. Follow the instructions provided in the *ULTRIX Basic Installation Guide*.

If you plan to use a tape drive to perform the basic installation you need to have an external hard disk drive as part of your workstation.

To Tailor Your Worksystem Software to Meet Special Needs

1. Read the release notes.
2. Perform the basic operating system installation as described in the *ULTRIX Basic Installation Guide*, until the guide asks you to choose the type of installation.
3. Then follow the instructions provided in the *ULTRIX Advanced Installation Guide*.

To Install Application Software Products

Follow the instructions in the installation guides that came with your software.

Installation Notes for Experienced Installers

The instructions given here assume that all power cords remain unplugged until step 10, and that power switches remain in the off (0) position until step 12.

Warning: *Turning on power before you are instructed to do so can cause injury and damage equipment.*

Installing the Basic DECstation 2100/3100

1. Review site requirements.
2. Unpack and check your shipment.
3. Set up the system unit.
4. Connect the video cable.
5. Attach the keyboard cable to the back of the system unit at the keyboard icon.
6. Attach the mouse cable to the back of the system unit at the mouse icon.
7. Connect the SCSI terminator to the SCSI connector on the system unit.
8. Install the ThickWire Ethernet loopback connector and terminate ThinWire Ethernet.

9. Set up the monitor.

Use the knob with the short screw for the VR150, VR160, and VR262 monitors. Use the knob with the long screw for the VR299 monitor. The VR297 monitor does not need a screw.

10. Connect the monitor-system unit power cable.

Caution: Connecting the monitor to a system unit that is receiving power from a source that does not meet the voltage requirements of the monitor can damage the monitor.

11. Connect the system unit power cord.

12. Turn on the DECstation by first turning on the monitor and then the system unit.

13. Check the results of the power-up self-test.

- If the testing is successful, the monitor shows a display similar to the following:

```
KN01 V6.71
08-00-2b-0d-f7-6a
0x010 0000
>>
```

- If the monitor screen remains blank, contact your system manager or refer to the troubleshooting chapter in the *DECstation 2100/3100 Operator's Guide*.

14. Give your Ethernet station address to your system manager.

Type **test -c** at the console prompt.

15. Install any optional peripheral devices according to the instructions given in "Installing Optional Peripheral Devices," the next section of this chapter.

16. Install your software.

Installing Optional Peripheral Devices

Caution: Attaching a peripheral device to the wrong connector on the system unit can damage the system unit and peripheral device.

To Install External Storage Devices

External storage devices come preinstalled in expansion boxes. You can connect as many as four expansion boxes to your system.

Connecting the first expansion box to the system unit

1. Set up the device and be sure the SCSI switches on the back of the box are set correctly.

See the *BA42 Storage Expansion Box Installation Guide* for information on how to set SCSI switches on drives in the BA42 expansion box.

- If your first box is a TK50Z tape drive, the settings are
Down Up Down
- If your first box is an RZ55 hard disk drive in its own expansion box, the settings are
Down Down Down
- If your first box is an RRD40 optical compact disc drive, the settings are
Up Down Down Down
- If your first box is a TLZ04 cassette tape drive, the settings are
Up Down Up Down

2. Attach the cable with two different connectors on it to the SCSI connector on the system unit and to one of the connectors on the back of the box.
3. If you are not attaching another expansion box, plug the SCSI terminator into the empty connector on the expansion box.

Connecting boxes after the first

1. Stack the boxes on top of the first box.
If you use an optical compact disc drive, always connect it last.
2. Set the SCSI switches for each box
 - a. Type **test -c** to display the configuration table.
 - b. Use the SCSI ID switch settings listed in Table 4-1 earlier in this guide.
3. Use the 18-inch expansion box cable with identical connectors at each end to connect the new expansion box to the installed box.

Caution: Using a cable other than the Digital-supplied 18-inch cable between expansion boxes can cause the boxes to malfunction.

Repeat this step for each additional box.

4. Plug the expansion box terminator into the empty connector on your final box.

To Install a Printer

1. Set up the printer and its cable according to the instructions that came with it.
2. Attach the printer cable to the back of the system unit at the printer icon.

See the documentation that came with your operating system for instructions on setting the baud rate in the DECstation 2100/3100 environment variables.

To install a Communications Device

- 1. Set up the device and its cable according to the instructions that came with it.**
- 2. Attach the communications device connector to the back of the system unit at the communications icon.**

See the documentation that came with your operating system for instructions on setting the baud rate in the DECstation 2100/3100 environment variables.

Ethernet Hardware Connections

This appendix tells you how to prepare your workstation for connection to ThinWire or ThickWire Ethernet.

If you have a ThickWire network, follow the instructions on page A-2. If you have a ThinWire network, turn to page A-4.

Connecting to a ThickWire Network

When connecting your workstation to a ThickWire network, you must have a 15-pin Ethernet cable.

To connect to a ThickWire network,

1. Turn off the system unit by pressing the 0 on the on/off switch on the back of the unit.
2. Position the cable connector so the widest part of the connector aligns with the widest part of the connector on the system unit.
3. Push the cable connector into the ThickWire connector, as shown in Figure A-1.
4. Find the slide latch, located at the right of the ThickWire connector.
5. Push it all the way to the left to lock the ThickWire cable connector in place.
6. Turn on the system unit by pressing the 1 on the on/off switch.

A light between the ThickWire Ethernet connector and the Ethernet button should glow green.

- If the light fails to glow, use the point of a ballpoint pen, or some similar tool, to press and release the Ethernet button, located to the right of the ThickWire connector.

Caution: The graphite in pencil lead can damage the system u. it.

- If the light still fails to glow, contact your Digital service representative.
7. Complete the network installation according to the instructions provided in the networking guide for your operating system.

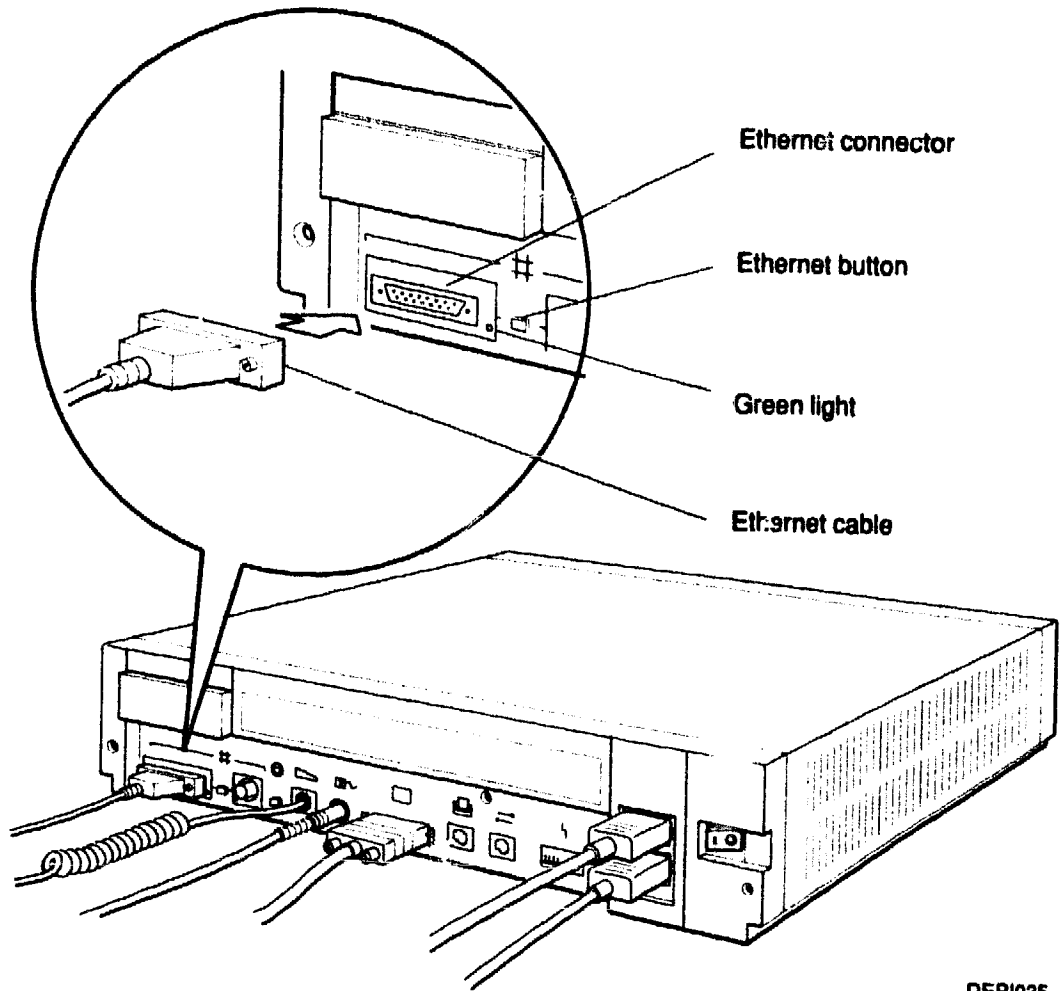

DEPI025

Figure A-1. Connecting the ThickWire ethernet cable

Connecting to a ThinWire Network

When connecting your workstation to the end of a ThinWire cable segment, you need one ThinWire cable. When connecting within a ThinWire cable segment, you need two ThinWire cables.

To connect to the end of a ThinWire segment, follow the instructions in the next section.

To connect within a ThinWire segment, follow the instructions on page A-7.

To Connect to the End of a ThinWire Segment

1. Turn off the system unit by pressing the 0 on the on/off switch on the back of the system unit.
2. Remove one terminator from the T-connector.

Turn the left-hand terminator away from you or the right-hand terminator toward you until you can pull it away from the T-connector.

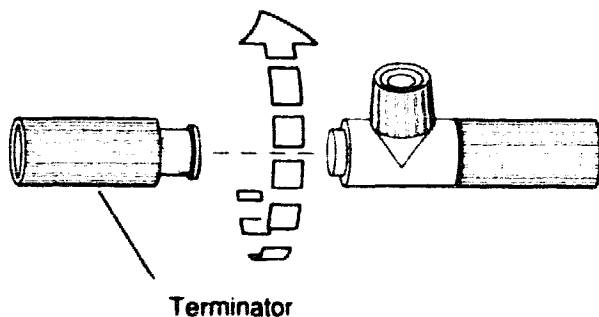

DEPI027

Figure A-2. Removing a Terminator from the T-Connector

3. Attach the cable connector to the free end of the T-connector.

Firmly push the cable connector into the T-connector and twist the cable connector until it slides forward and locks into place.

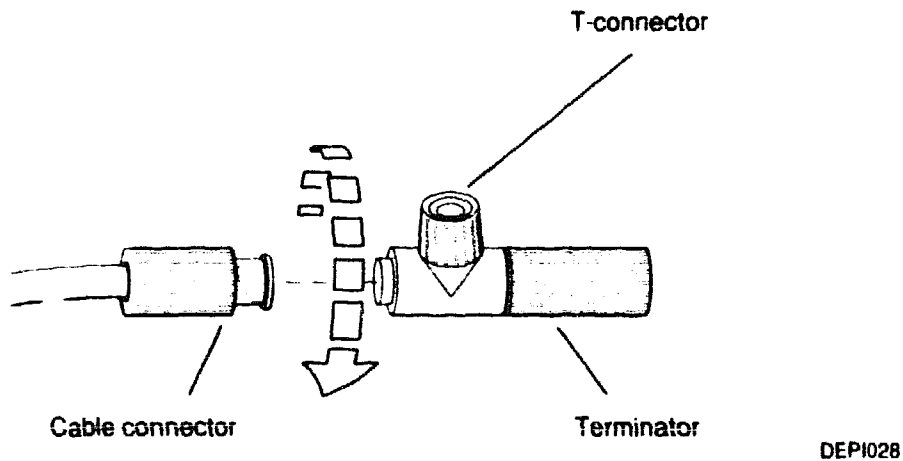

Figure A-3. Connecting the ThinWire Cable to the T-Connector

4. Push the ribbed portion of the T-connector into the ThinWire Ethernet connector below the Ethernet icon on the back of the system unit.
5. Twist the T-connector from side to side until it slips into place and you can push it onto the connector on the system unit.
6. Twist the ribbed portion of the connector to the right until it locks into place.
7. Turn on the system unit by pressing the 1 on the on/off switch.

A light should glow green to the left of the T-connector.

- If the light fails to glow, use the point of a ballpoint pen, or some similar tool, to press and release the Ethernet button, located to the left of the ThinWire connector.

Caution: The graphite in pencil lead can damage the system unit.

- If the light still fails to glow, contact your Digital service representative.

8. Complete the network installation according to the instructions provided in the networking guide for your operating system.

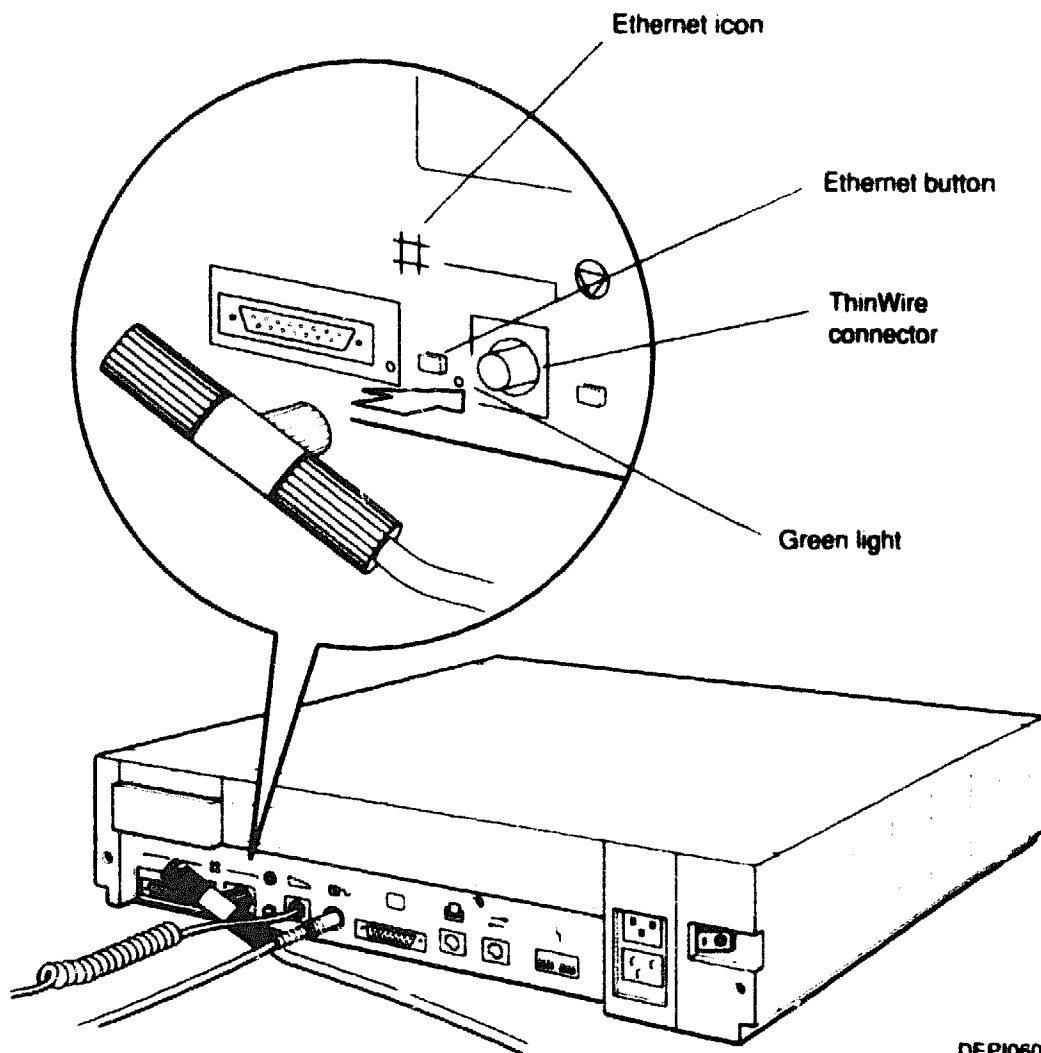

DEPI060

Figure A-4. Connecting one ThinWire cable

To Connect Within a ThinWire Segment

1. Turn off the system unit by pressing the 0 on the on/off switch on the back of the unit.
2. Remove both terminators from the T-connector.

Turn the right-hand terminator toward you and the left-hand terminator away from you until you can pull them away from the T-connector.

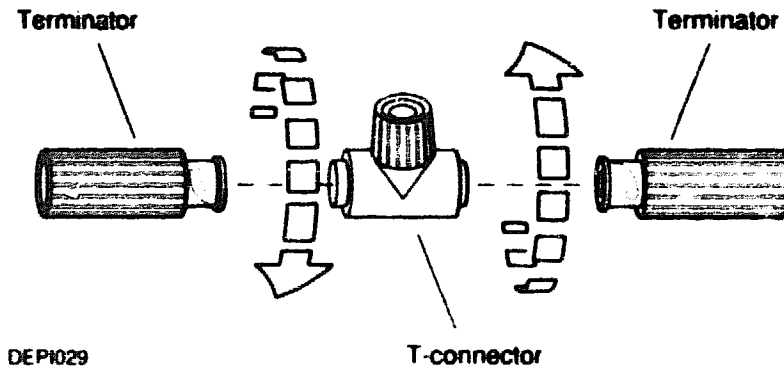

Figure A-5. Removing the Terminators from the T-Connector

3. Attach the cable connectors to the T-connector.

Firmly push each cable connector into the T-connector and twist the cable connector until they slide forward and lock into place.

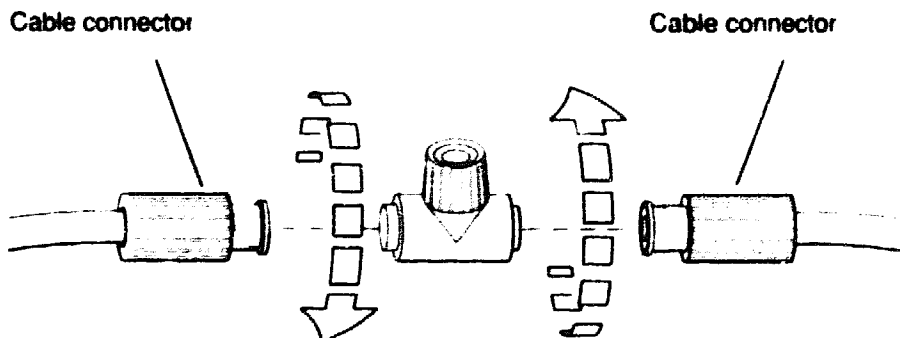

Figure A-6. Connecting the ThinWire Cables to the T-Connector

4. Push the ribbed portion of the T-connector into the ThinWire Ethernet connector below the Ethernet icon on the back of the system unit.
5. Twist the T-connector from side to side until it slips into place and you can push it onto the connector on the system unit.
6. Twist the ribbed portion of the connector to the right until it locks into place.
7. Turn on the system unit by pressing the 1 on the on/off switch.

A light should glow green to the left of the T-connector.

- If the light fails to glow, use the point of a ballpoint pen, or some similar tool, to press and release the Ethernet button, located to the left of the ThinWire connector.

Caution: The graphite in pencil lead can damage the system unit.

- If the light still fails to glow, contact your Digital service representative.
8. Complete network installation according to the instructions provided in the networking guide for your operating system.

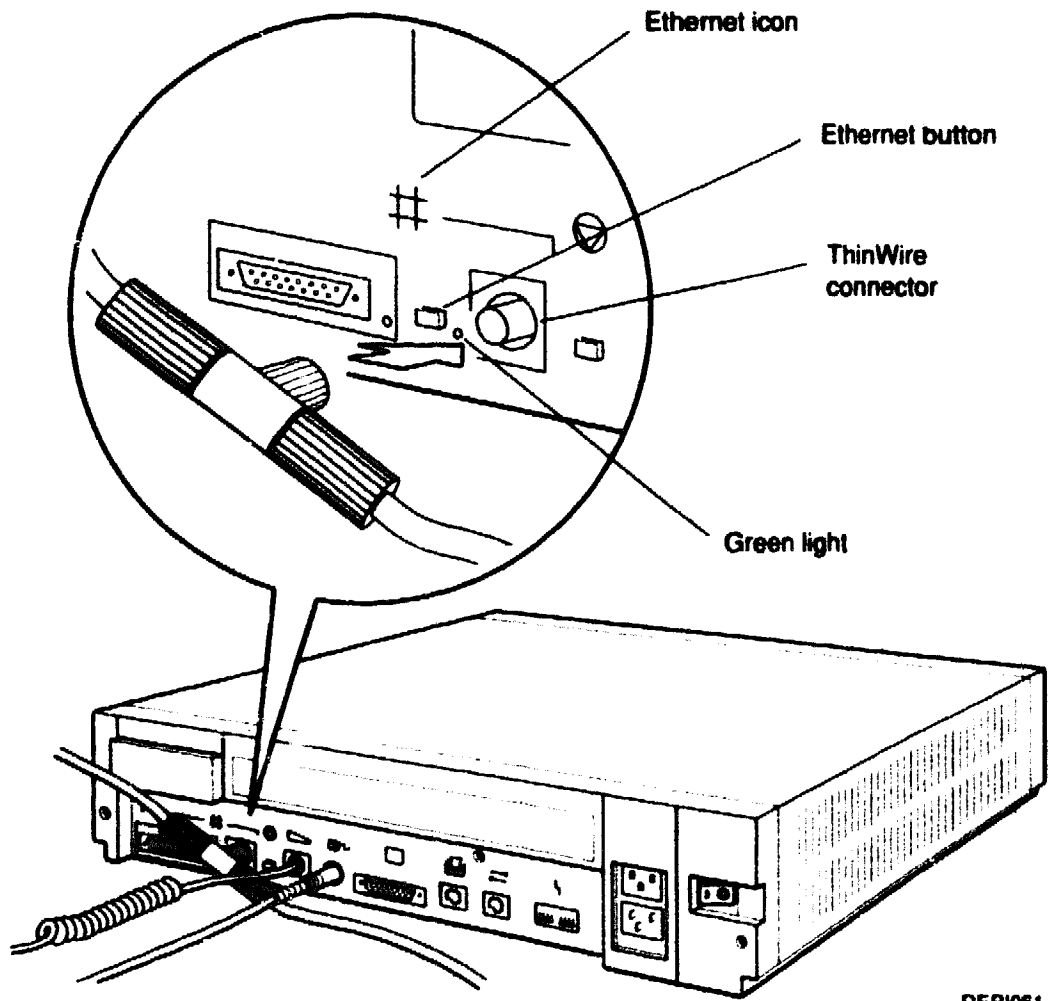

Figure A-7. Connecting two ThinWire cables

DECstation 2100/3100

Operator's Guide

digital equipment corporation
maynard, massachusetts

First printing, January 1989
Revised, July 1989
Revised, January 1991

The information in this document is subject to change without notice and should not be construed as a commitment by Digital Equipment Corporation. Digital Equipment Corporation assumes no responsibility for any errors that may appear in this document.

The software described in this document is furnished under a license and may be used or copied only in accordance with the terms of such license.

Digital Equipment Corporation assumes no responsibility for the use or reliability of its software on equipment that is not supplied by Digital or its affiliated companies.

© Digital Equipment Corporation 1989, 1991.
All Rights Reserved
Printed in U.S.A.

U.S.A.

This equipment generates, uses, and may emit radio frequency energy. The equipment has been type tested and found to comply with the limits for a Class A computing device pursuant to Subpart J of Part 15 of FCC Rules, which are designed to provide reasonable protection against such radio frequency interference. Operation of this equipment in a residential area may cause interference in which case the user at his own expense will be required to take whatever measures may be required to correct the interference.

The following are trademarks of Digital Equipment Corporation:

DEC	PDP	VAXcluster
DECnet	ThinWire	VAXstation
DECstation	ULTRIX	VMS
DECsystem	ULTRIX-32	VT
DECUS	UNIBUS	
MicroVAX	VAX	
MicroVMS	VAXBI	

Contents

Using This Guide	xi
1 Basic DECstation 2100/3100 Hardware	
The System Unit	1-2
The Monitor	1-5
Adjusting the Position of the Monitor	1-11
For the VR150, VR160, and VR297 monitors	1-11
For the VR299 color monitor	1-12
The Keyboard	1-13
Adjusting the Keyboard	1-13
The Mouse	1-14
Cleaning the Mouse	1-15
2 Hardware Options	
Adding Memory	2-1
To Add Memory Modules	2-1
Adding Storage	2-2
Internal Storage Devices	2-3
External Storage Devices	2-3
Adding a Printer	2-4
To Add a Printer	2-4
Adding a Modem	2-5
To Add a Modem	2-5

3 Using DECstation 2100/3100 Hardware

Turning On Your Workstation	3-2
For a Workstation on a Power Strip	3-2
For a Workstation Not on a Power Strip	3-3
Turning Off Your Workstation	3-5
For a Workstation on a Power Strip	3-5
For a Workstation Not on a Power Strip	3-5
Using the Configuration Display	3-6
To Display Your Workstation Configuration	3-6
Using Console Commands	3-9
Booting the Worksystem Software	3-10
Setting the Workstation for Automatic Booting	3-10
Shutting Down the Worksystem Software	3-11

4 Using Tape Drives

Checking the Position of the Tape Leader Inside a Cartridge	4-3
Write-Protecting a Cartridge	4-5
Write-Enabling a Cartridge	4-6
Checking the Take-Up Leader Inside the Drive	4-7
Loading a Tape Cartridge	4-8
Removing a Tape Cartridge	4-13
Labeling a Tape Cartridge	4-16

5 Using an Optical Compact Disc Drive

Connectors, Controls, and Indicator Lights on the Disc Drive	5-2
Using an Optical Compact Disc Drive	5-4
To Load a Disc into a Drive	5-5
To Unload a Disc from a Drive	5-8
Handling Compact Discs	5-9
To Unload a Disc from Its Caddy	5-10
To Load a Disc into Its Caddy	5-12
Cleaning a Compact Disc	5-16
For Further Information	5-16

6 Using the RX23 Diskette Drive

Using Diskettes	6-3
To Write-Protect a Diskette	6-4
To Write-Enable a Diskette	6-5
Inserting a Diskette into a Drive	6-6
Removing a Diskette from a Drive	6-8
To Remove a Diskette from a Drive	6-8
Formatting a Diskette	6-9
To Use the Console Program	6-9
To Continue Formatting the Diskette	6-11
If you are not using a high-density diskette or if your diskette is write-protected	6-12
To Terminate the Formatting Procedure	6-13
To Use Worksystem Software	6-13

7 Troubleshooting

Using the Self-Test	7-2
If a Subtest Fails	7-4
If Subtest 7, 6, 5, or 4 Fails	7-4
If Subtest 3 Fails	7-4
If Subtest 2 Fails	7-6
For a workstation not on a network	7-6
For a workstation on ThickWire Ethernet	7-7
For a workstation on ThinWire Ethernet	7-8
If Subtest 1 Fails	7-9
For a workstation with no external storage devices	7-9
For a workstation with external storage devices	7-10
Solving Hardware Problems	7-11
Contacting Your Digital Service Representative	7-18

8 Moving the DECstation 2100/3100 Workstation

Dismantling the Workstation	8-2
Packing Your Equipment	8-3
Reinstalling Your DECstation 2100/3100	8-3

A Equipment Specifications

B Part Numbers

C Console Commands

Conventions Used in This Appendix	C-3
Getting Help	C-4
Console Commands	C-5
The auto Command	C-6
The boot Command	C-6
The ctrs Command	C-8
The d (deposit) Command	C-9
The disable Command	C-10
The dump Command	C-10
The e (examine) Command	C-12
The enable Command	C-13
The fill Command	C-14
The go Command	C-15
The help Command	C-15
The ? Command	C-15
The init Command	C-16
The passwd Command	C-16
The printenv Command	C-17
The setenv Command	C-21
The test Command	C-21
The unsetenv Command	C-22

D Interpreting the Self-Test

Using the Power-Up Self-Test	D-1
Interpreting Monitor Self-Test Codes	D-2
Interpreting LED Self-Test Codes	D-3

Index

Figures

1-1	The basic DECstation 2100/3100 hardware	1-1
1-2	The back of the system unit	1-2
1-3	System unit icons	1-4
1-4	Monitor icons	1-5
1-5	The VR150 monochrome monitor	1-6
1-6	The VR160 color monitor	1-7
1-7	The VR262 monochrome monitor	1-8
1-8	The VR297 color monitor	1-9
1-9	The VR299 color monitor	1-10
1-10	The keyboard	1-13
1-11	The mouse	1-14
1-12	Removing the tracking ball from the mouse	1-15
2-1	Expansion boxes	2-3
3-1	Sample configuration display	3-6
4-1	The tape drive	4-2
4-2	Opening the door on the cartridge	4-3
4-3	A tape leader positioned correctly in the cartridge	4-4
4-4	A write-protected cartridge	4-5
4-5	A write-enabled cartridge	4-6
4-6	A take-up leader positioned correctly in the drive	4-7
4-7	Pressing the load/unload button on a tape drive	4-8
4-8	Lifting the insert/release handle on a tape drive	4-9
4-9	Inserting a tape drive	4-10
4-10	Lowering the insert/release handle on a tape drive	4-11
4-11	Pressing the load/unload button on a tape drive	4-13
4-12	Lifting the insert/release handle on a tape drive	4-14
4-13	Removing a tape cartridge	4-15
4-14	Labeling a tape cartridge	4-16
5-1	The optical compact disc drive	5-1
5-2	Connectors, controls, and indicator lights on the drive	5-2
5-3	The parts of a disc caddy	5-4
5-4	Turning on the drive	5-5
5-5	Positioning the caddy	5-6
5-6	Inserting the caddy	5-7
5-7	Positioning the protective sleeve	5-8
5-8	A compact disc	5-9
5-9	Beginning to remove the frame	5-10

5-10	Holding the disc	5-11
5-11	Positioning the disc	5-12
5-12	Positioning the frame	5-13
5-13	Placing the disc inside the frame	5-14
5-14	Inserting the disc and frame into the sleeve	5-15
6-1	The internal diskette drive	6-1
6-2	An RX23K diskette	6-2
6-3	Write-protecting a diskette	6-4
6-4	Write-enabling a diskette	6-5
6-5	A diskette positioned for insertion	6-6
6-6	A diskette positioned correctly in the drive	6-7
6-7	Ejecting a diskette from the drive	6-8
6-8	The indicator light on the diskette drive	6-11
7-1	The on/off switch and reset button on the system unit	7-2
7-2	Checking the mouse and keyboard connections	7-5
7-3	Checking Ethernet connections	7-6
7-4	Checking ThickWire connections	7-7
7-5	Checking ThinWire connections	7-8
7-6	Checking the SCSI terminator	7-9
7-7	Checking SCSI connections	7-10

Tables

1	Conventions Used in This Guide	xi
1-1	Connectors, Controls, and Indicator Lights on the System Unit	1-3
1-2	Controls, Connectors, and Indicator Lights on the Monitors	1-11
3-1	Shutdown Commands	3-11
5-1	Connectors, Controls, and Indicator Lights on the Disc Drive	5-3
7-1	Solutions to Common Hardware Problems	7-11
A-1	System Unit Description	A-2
A-2	System Specifications	A-2
A-3	System Unit Operating Conditions	A-2
A-4	System Unit Nonoperating Conditions	A-2
A-5	VR150 Monitor Description	A-3
A-6	VR150 Monitor Specifications	A-3
A-7	VR150 Monitor Operating Conditions	A-4

A-8	VR150 Monitor Nonoperating Conditions	A-5
A-9	VR160 Monitor Description	A-6
A-10	VR160 Monitor Specifications	A-6
A-11	VR160 Monitor Operating Conditions	A-7
A-12	VR160 Monitor Nonoperating Conditions	A-7
A-13	VR262 Monitor Description	A-8
A-14	VR262 Monitor Specifications	A-8
A-15	VR262 Monitor Operating Conditions	A-9
A-16	VR262 Monitor Nonoperating Conditions	A-10
A-17	VR297 Monitor Description	A-11
A-18	VR297 Monitor Specifications	A-11
A-19	VR297 Monitor Operating Conditions	A-12
A-20	VR297 Monitor Nonoperating Conditions	A-12
A-21	VR299 Monitor Description	A-13
A-22	VR299 Monitor Specifications	A-13
A-23	VR299 Monitor Operating Conditions	A-15
A-24	VR299 Monitor Nonoperating Conditions	A-15
A-25	LK201 Keyboard Description	A-16
A-26	LK201 Keyboard Specifications	A-16
A-27	LK201 Keyboard Operating Conditions	A-16
A-28	LK201 Keyboard Nonoperating Conditions	A-17
A-29	VSXXX-AA Mouse Description	A-18
A-30	VSXXX-AA Mouse Specifications	A-18
A-31	VSXXX-AA Mouse Operating Conditions	A-18
A-32	VSXXX-AA Mouse Nonoperating Conditions	A-19
A-33	RZ55 SCSI Hard Disk Drive Description	A-20
A-34	RZ55 SCSI Hard Disk Drive Specifications	A-20
A-35	RZ55 SCSI Hard Disk Drive Operating Conditions	A-21
A-36	RZ55 SCSI Hard Disk Drive Nonoperating Conditions	A-21
A-37	TK50Z Tape Drive Description	A-22
A-38	TK50Z Tape Drive Specifications	A-22
A-39	TK50Z Tape Drive Operating Conditions	A-22
A-40	TK50Z Tape Drive Nonoperating Conditions	A-23
A-41	TLZ04 Cassette Tape Drive Description	A-24
A-42	TLZ04 Cassette Tape Drive Specifications	A-24
A-43	TLZ04 Cassette Tape Drive Operating Conditions	A-24
A-44	TLZ04 Cassette Tape Drive Nonoperating Conditions	A-24
A-45	RRD40 Compact Disc Drive Description (Tabletop)	A-25
A-46	RRD40 Compact Disc Drive Specifications (Tabletop)	A-25

A-47	RRD40 Compact Disc Drive Operating Conditions (Tabletop)	A-25
A-48	RRD40 Compact Disc Drive Nonoperating Conditions (Tabletop)	A-25
A-49	RZ23 SCSI Hard Disk Drive Description	A-26
A-50	RZ23 SCSI Hard Disk Drive Specifications (formatted)	A-26
A-51	RZ23 SCSI Hard Disk Drive Operating Conditions	A-26
A-52	RZ23 SCSI Hard Disk Drive Nonoperating Conditions	A-27
A-53	RZ23L SCSI Hard Disk Drive Description	A-28
A-54	RZ23L SCSI Hard Disk Drive Specifications (formatted)	A-28
A-55	RZ23L SCSI Hard Disk Drive Operating Conditions	A-28
A-56	RZ23L SCSI Hard Disk Drive Nonoperating Conditions	A-29
A-57	RZ24 SCSI Hard Disk Drive Description	A-30
A-58	RZ24 SCSI Hard Disk Drive Specifications	A-30
A-59	RZ24 SCSI Hard Disk Drive Operating Conditions	A-31
A-60	RZ24 SCSI Hard Disk Drive Nonoperating Conditions	A-31
A-61	RX23 Floppy Disk Drive Description	A-32
A-62	RX23 Floppy Disk Drive Specifications (formatted)	A-32
A-63	RX23 Floppy Disk Drive Operating Conditions	A-33
A-64	RX23 Floppy Disk Drive Nonoperating Conditions	A-33
B-1	Basic Components	B-1
B-2	BA42 Storage Expansion Box Configuration	B-3
B-3	Cords, Cables, and Connectors	B-4
B-4	Software Documentation	B-5
B-5	Hardware Documentation	B-6
C-1	Console Commands	C-5
C-2	Default Environment Variables	C-18
D-1	Monitor Self-Test Display Codes	D-2
D-2	LED Self-Test Display Codes	D-3

Using This Guide

Use this guide to learn to use and troubleshoot your DECstation 2100/3100 hardware.

This guide tells you:

- How to use the connectors, controls, and indicator lights on your workstation hardware
- How to adjust your workstation hardware for your comfort
- What options you can use to increase your workstation's performance
- How to use a tape drive, an optical compact disc drive, and a diskette drive
- How to diagnose and solve hardware problems
- How to dismantle and pack your workstation in preparation for moving

Table 1. Conventions Used in This Guide

Convention	Use
Monospace type	Anything that appears on your monitor screen is set in monospace, like this.
Boldface type	Anything you are asked to type is set in boldface, like this.
	<i>Note:</i> All commands typed at the console level are case sensitive. The workstation does not recognize uppercase and lowercase letters as the same input.

Basic DECstation 2100/3100 Hardware

This chapter describes the four basic parts of the DECstation 2100/3100 workstation: the system unit, monitor, keyboard, and mouse.

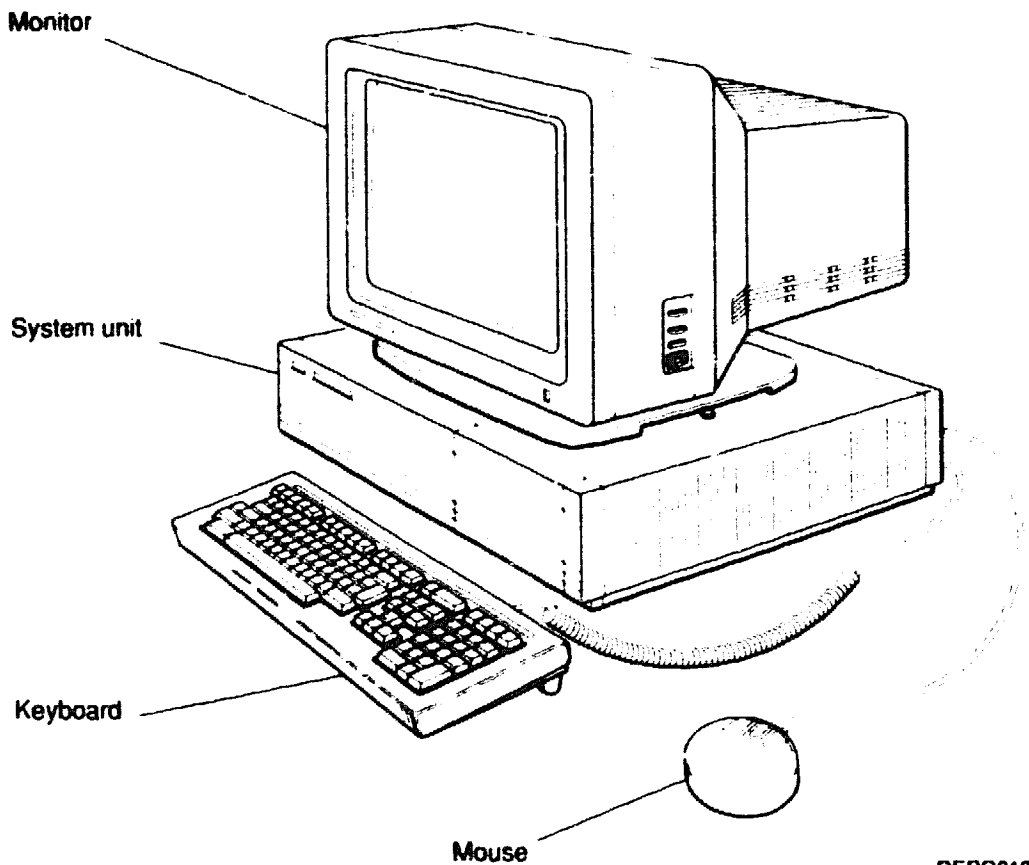

DEPG018

Figure 1-1. The basic DECstation 2100/3100 hardware

The System Unit

The system unit is designed to sit flat on your desk with the monitor placed on top of or next to it.

Caution: *Standing the system unit on its side blocks vents and can damage the unit.*

If you look at the back of the system unit, you can see, starting in the upper-left corner and moving from left to right, the connectors, controls, and indicator lights pictured in Figure 1-2 and described in Table 1-1. Figure 1-3 shows the icons that appear on the system unit.

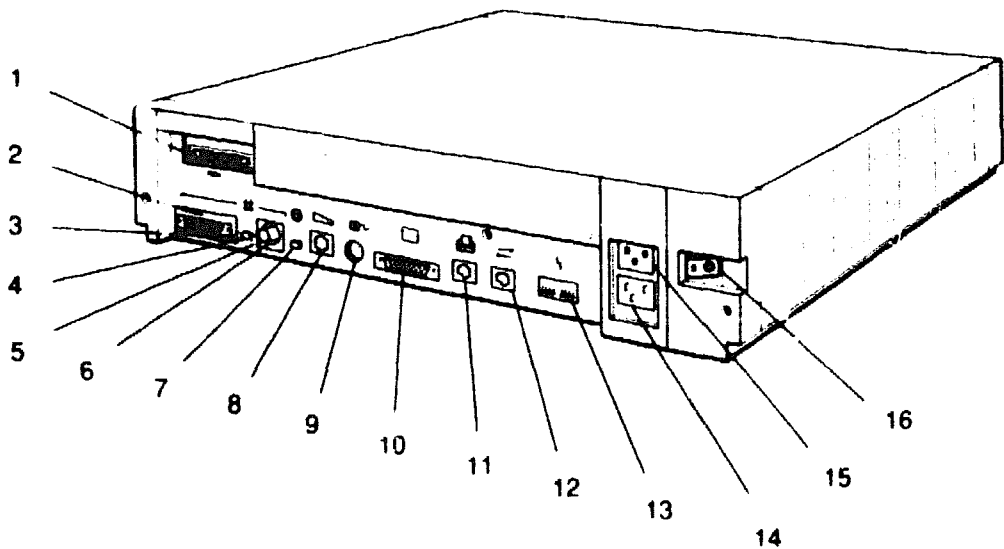

- | | |
|---------------------------------------|---|
| 1. SCSI connector | 9. Mouse connector |
| 2. ThickWire Ethernet connector | 10. Monitor connector |
| 3. ThickWire Ethernet indicator light | 11. Printer connector |
| 4. Ethernet button | 12. Communications connector |
| 5. ThinWire Ethernet indicator light | 13. Diagnostic indicator lights |
| 6. ThinWire Ethernet connector | 14. System unit power connector |
| 7. Reset button | 15. Monitor-system unit power connector |
| 8. Keyboard connector | 16. On/off switch |

DEPG019

Figure 1-2. The back of the system unit

Table 1-1. Connectors, Controls, and Indicator Lights on the System Unit

Item	Function
SCSI connector	The point at which external small computer system interface (SCSI) storage devices connect to the system unit. If you have no such devices, this connector must be covered with a terminator.
ThickWire connector	The point at which ThickWire Ethernet connects to the system unit.
ThickWire light	Glows green on a workstation selected for ThickWire Ethernet.
Ethernet button	Activates your ThinWire or ThickWire Ethernet connection. When your workstation is connected to ThickWire Ethernet, the light to the right of the ThickWire Ethernet connector glows green. When your workstation is connected to ThinWire Ethernet, the light to the left of the ThinWire T-connector glows green.
ThinWire light	Glows green on a workstation selected for ThinWire Ethernet.
ThinWire connector	The point at which ThinWire Ethernet connects to the system unit.
Reset button	Returns you to the console prompt.
Keyboard connector	The point at which the keyboard connects to the system unit.
Mouse connector	The point at which the mouse connects to the system unit.
Monitor connector	The point at which the video cable connects the monitor to the system unit.
Printer connector	The point at which a printer connects to the system unit.
Communications connector	The point at which a communications device connects to the system unit.
Diagnostic lights	Indicate where system failures occurred.
System unit power connector	The point at which power from the power source reaches the system unit.
Monitor-system unit power connector	The point at which power passes from the system unit to the monitor.
On/off switch	Turns the system unit on and off. Pressing the 1 turns the system on. Pressing the 0 turns it off.

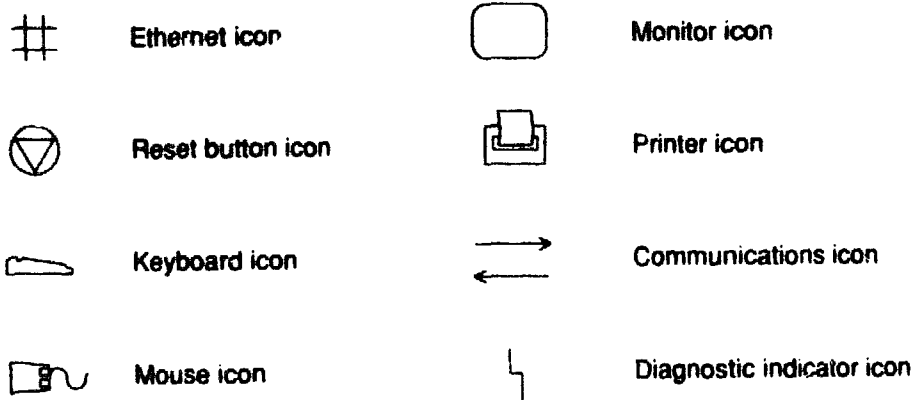

DEPG031

Figure 1-3. System unit icons

The Monitor

Caution: *Connecting or disconnecting your monitor while power is turned on can damage the monitor.*

Your DECstation 2100/3100 came with one of the following:

- VR150 15-inch monochrome monitor
- Vx160 15-inch color monitor
- VR297 16-inch color monitor
- VR262 19-inch monochrome monitor
- VR299 19-inch color monitor

Connectors, controls, and indicator lights are located in different places on the different monitors. Look at the illustration of your monitor to see where to find them.

Figure 1-4 shows the icons that appear on the monitors. Figures 1-5 through 1-9 show the various monitors. Table 1-2 describes the controls, connectors, and indicator lights on the monitors.

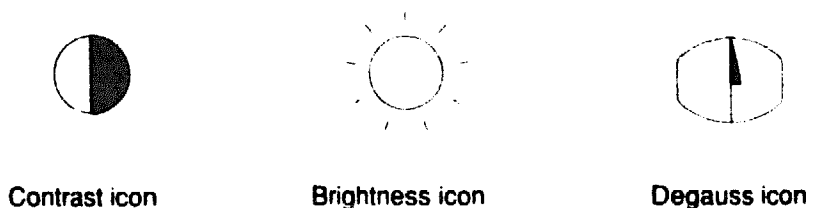

DEPI023

Figure 1-4. Monitor icons

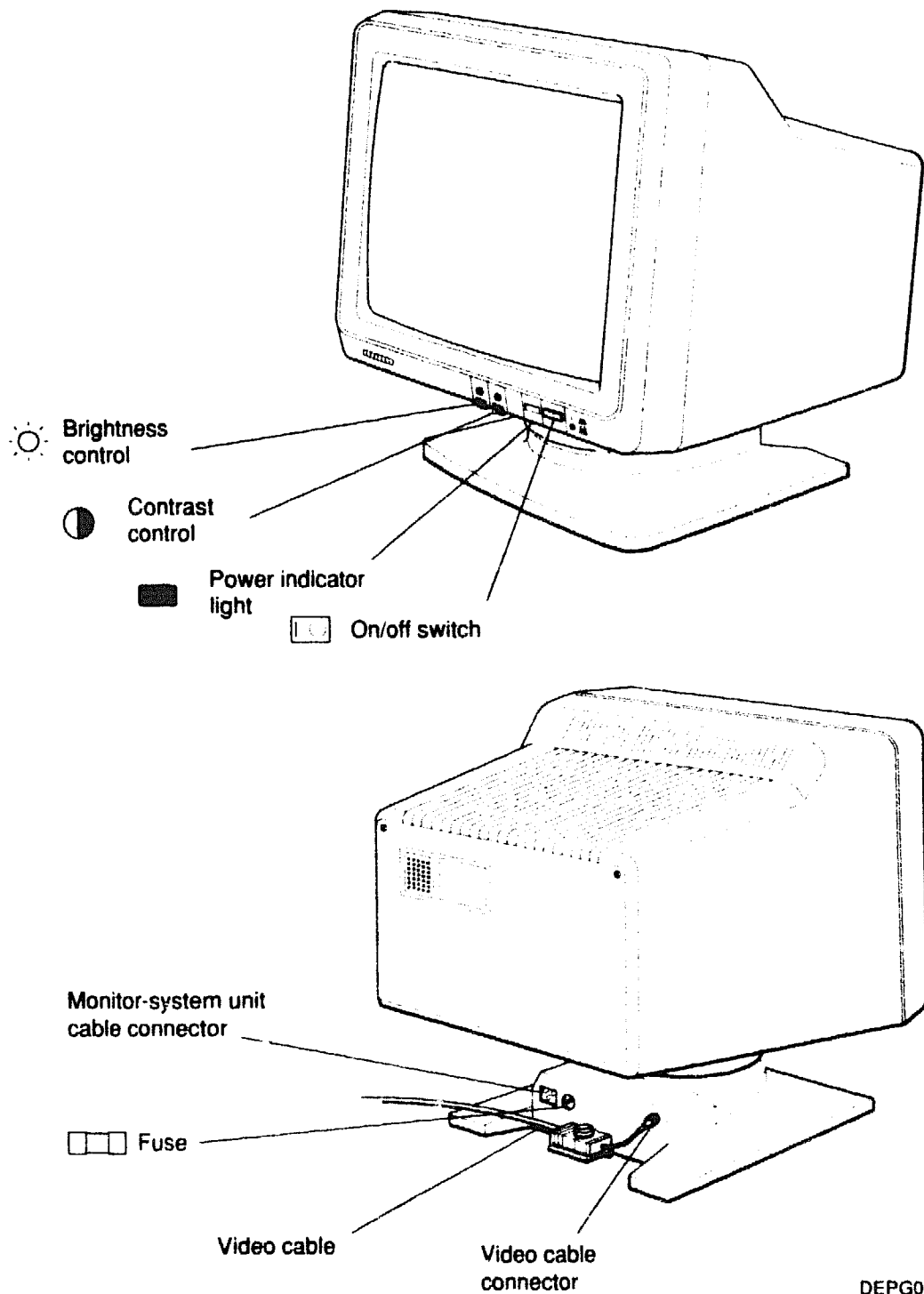

DEPG004

Figure 1-5. The VR150 monochrome monitor

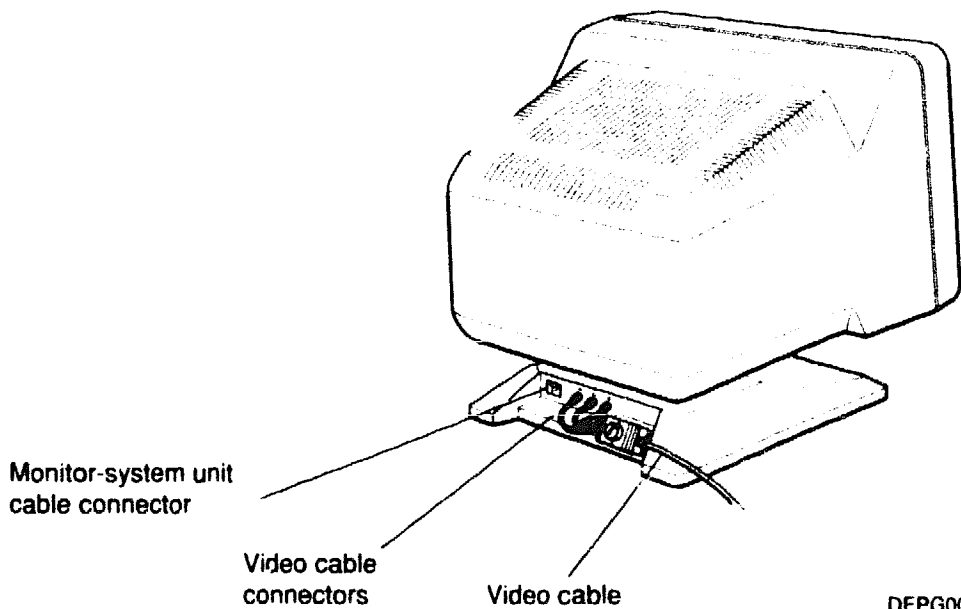
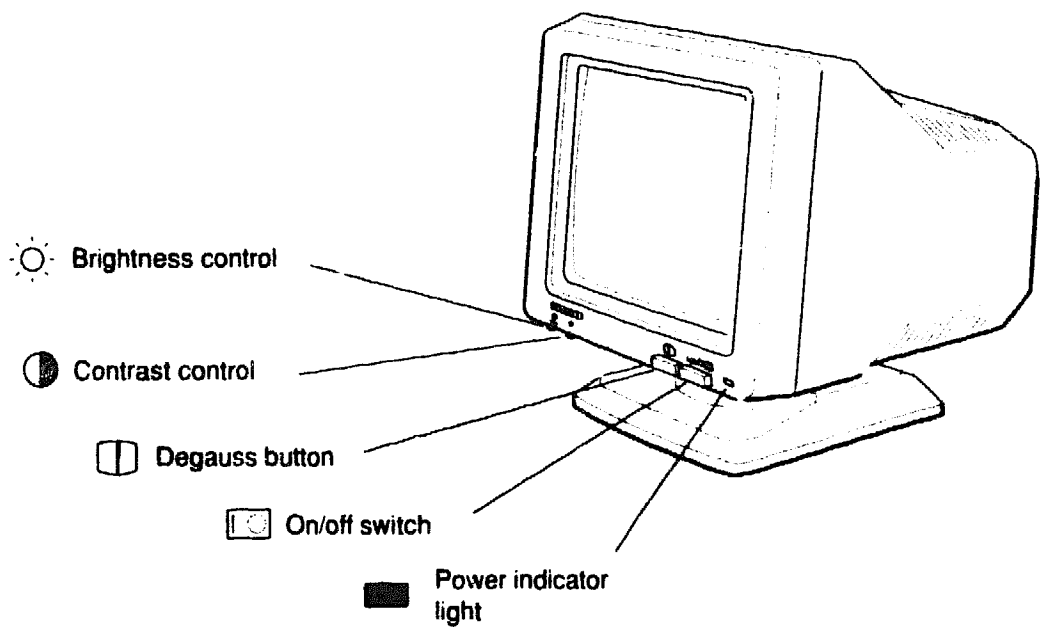

DEPG005

Figure 1-6. The VR160 color monitor

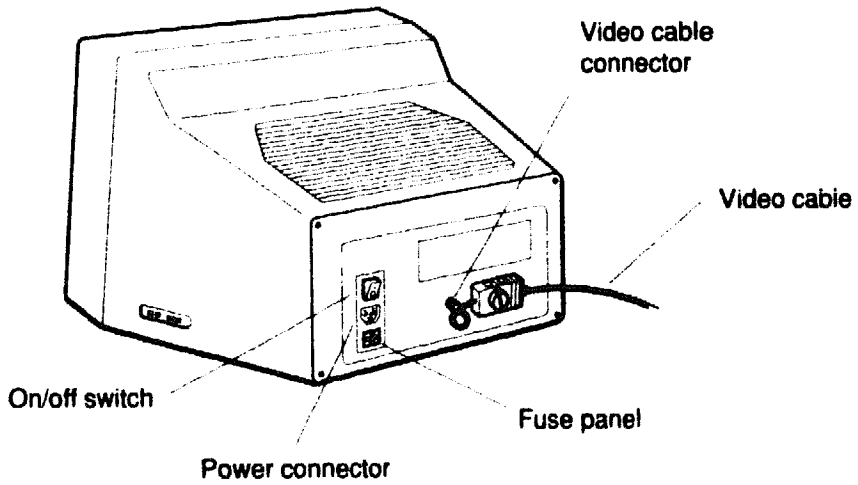
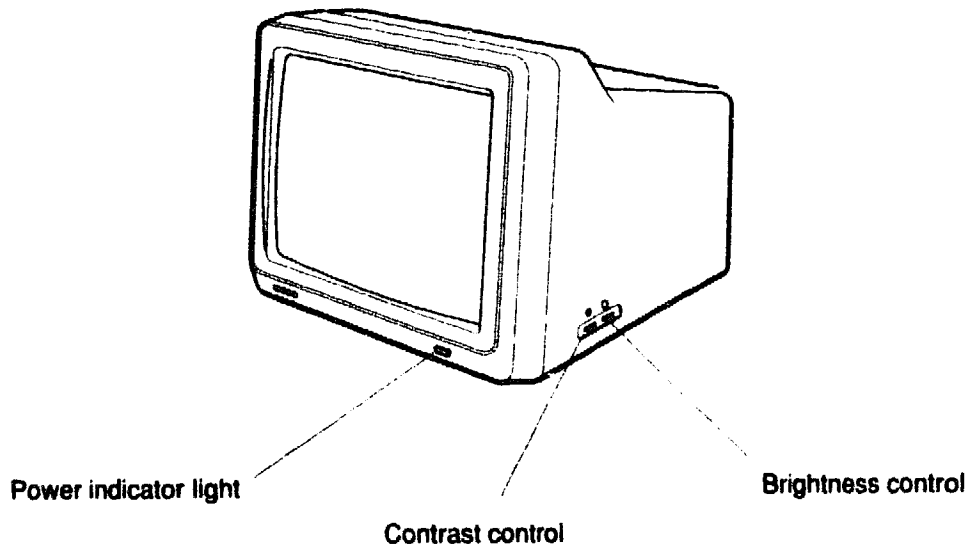

DEPG006

Figure 1-7. The VR262 monochrome monitor

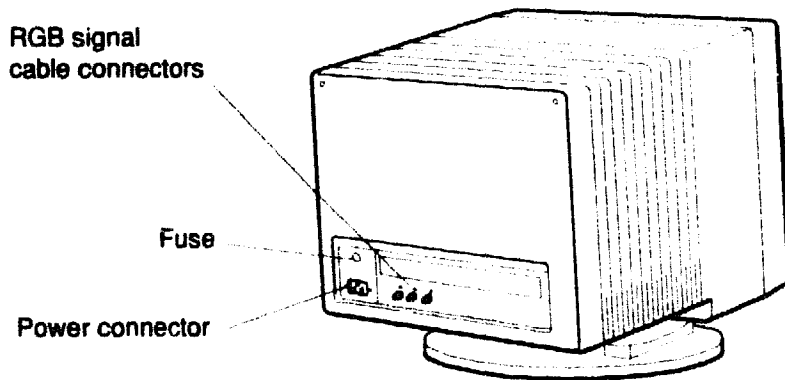
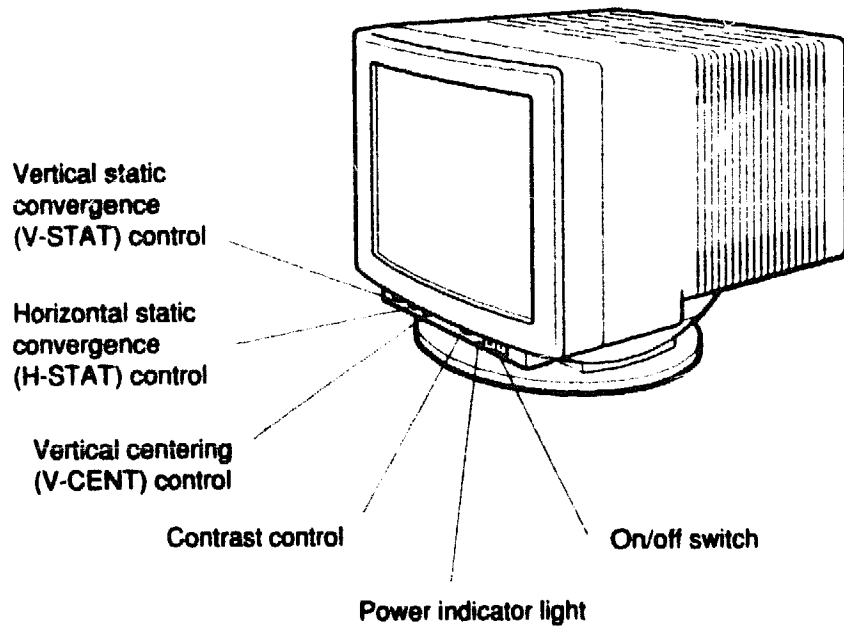

WSE20006

Figure 1-8. The VR297 color monitor

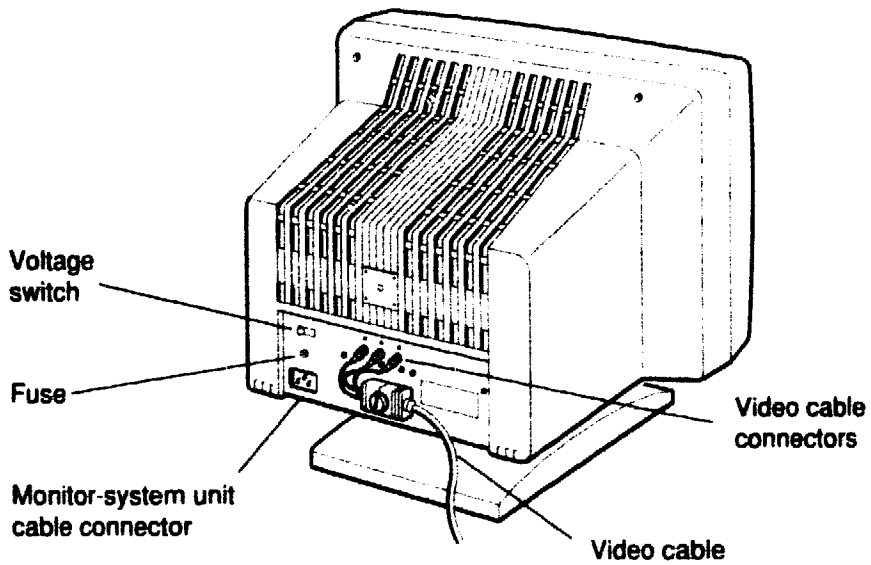
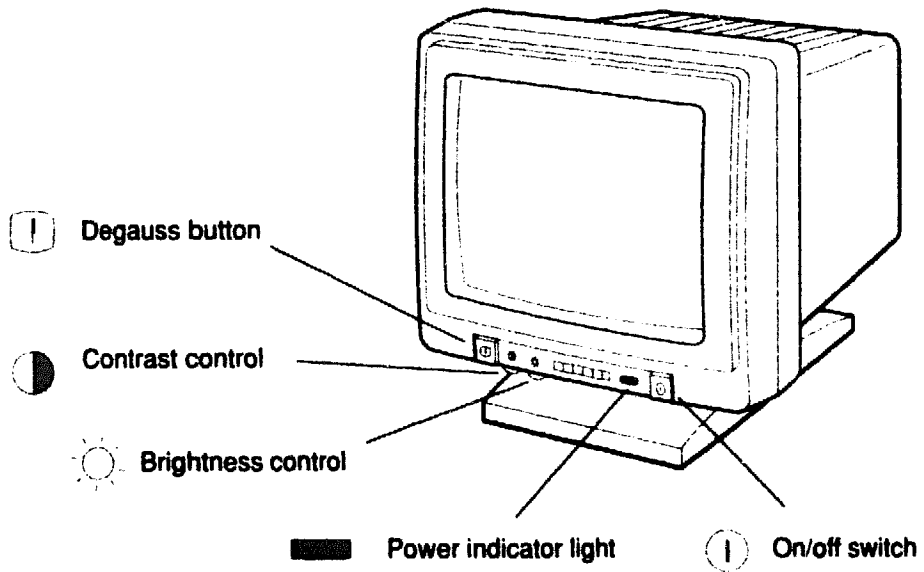

DEPG007

Figure 1-9. The VR299 color monitor

Table 1-2. Controls, Connectors, and Indicator Lights on the Monitors

Item	Function
Power indicator light	Glows green when the monitor receives power from the system unit.
Contrast control	Allows you to adjust the intensity of the display on your screen.
Brightness control	Allows you to adjust the brightness of the background on the screen.
Video cable	Allows video signals to flow between the monitor and the system unit. (Monochrome monitors have one connector; color monitors have three.)
Fuse	Protects the monitor from electrical damage.
Voltage switch	On the 19-inch monochrome monitor, lets you match the monitor's voltage to the voltage at your power source.
Monitor-system unit cable connector	Allows power to flow from the system unit to the monitor.
On/off switch	Turns the monitor on and off.
Degauss button	On color monitors, lets you clear color distortion caused by outside magnetic interference.
Tilt-lock lever	On the 19-inch color monitor, lets you adjust the tilt of the monitor and then lock it into the position you have chosen.

Adjusting the Position of the Monitor

Caution: *Swiveling the monitor in a complete circle can damage the base.*

All monitors except the VR262 monochrome monitor can be tilted and swiveled into the position that is most comfortable for you.

For the VR150, VR160, and VR297 monitors

The VR150 monochrome and VR160 and VR297 color monitors all come with built-in tilt-swivel stands that do not lock into place.

To set the angle of your monitor, slowly tilt the monitor forward or backward to the desired position.

You can turn the monitor from side to side without changing the tilt angle.

For the VR299 color monitor

The 19-inch color monitor comes with a built-in tilt-swivel mechanism and a tilt-lock lever that locks the monitor into the tilt position you select.

- **Push the lever toward the rear of the monitor to unlock the tilting mechanism.**
- **Pull the lever all the way forward to lock the tilting mechanism. The monitor can be swiveled from side to side at any time; there is no control that locks it into place.**

The Keyboard

Caution: *Connecting or disconnecting the keyboard while the system is turned on can damage the keyboard.*

The main part of your keyboard resembles a typewriter keyboard. Your keyboard also has some special function keys. The documentation that came with your software explains how to use these keys.

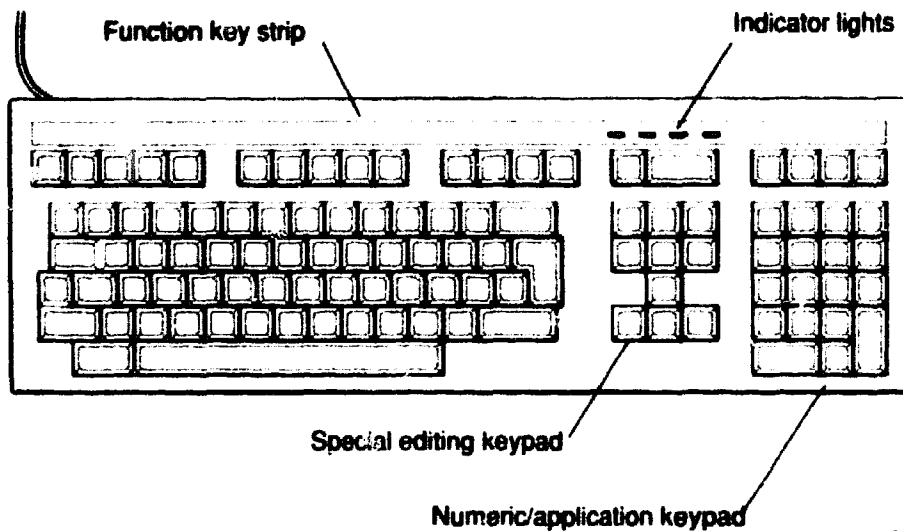

DEPG001

Figure 1-10. The keyboard

Adjusting the Keyboard

Your keyboard is shipped with the cable coming out of the right side. You can adjust the keyboard cable so it comes out of the left side if you prefer. You can also adjust the typing angle of your keyboard.

See the documentation that came with your keyboard for instructions on how to make these adjustments.

The Mouse

Caution: *Connecting or disconnecting the mouse while the system unit is turned on can damage the mouse.*

The mouse is a hand-held pointing device that lets you easily position the cursor on your screen.

The way you use your mouse depends on the software you use. The documentation that came with your software explains how to use your mouse.

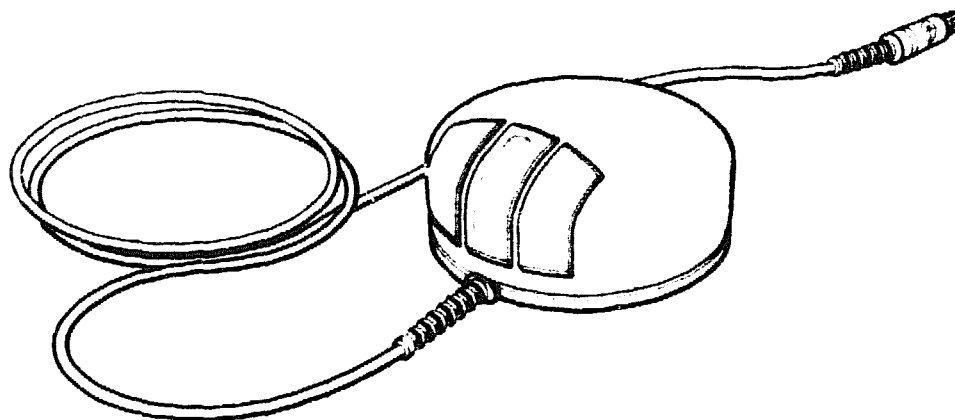

DEPG017

Figure 1-11. The mouse

Cleaning the Mouse

Clean the mouse when it fails to move the cursor smoothly on the screen.

To clean the mouse,

1. Turn the mouse upside down.
2. Release the round plate from the bottom of the mouse by placing your fingers in the grooves on the plate and turning the plate to the left.
3. Lift off the plate and remove the tracking ball from inside the mouse.

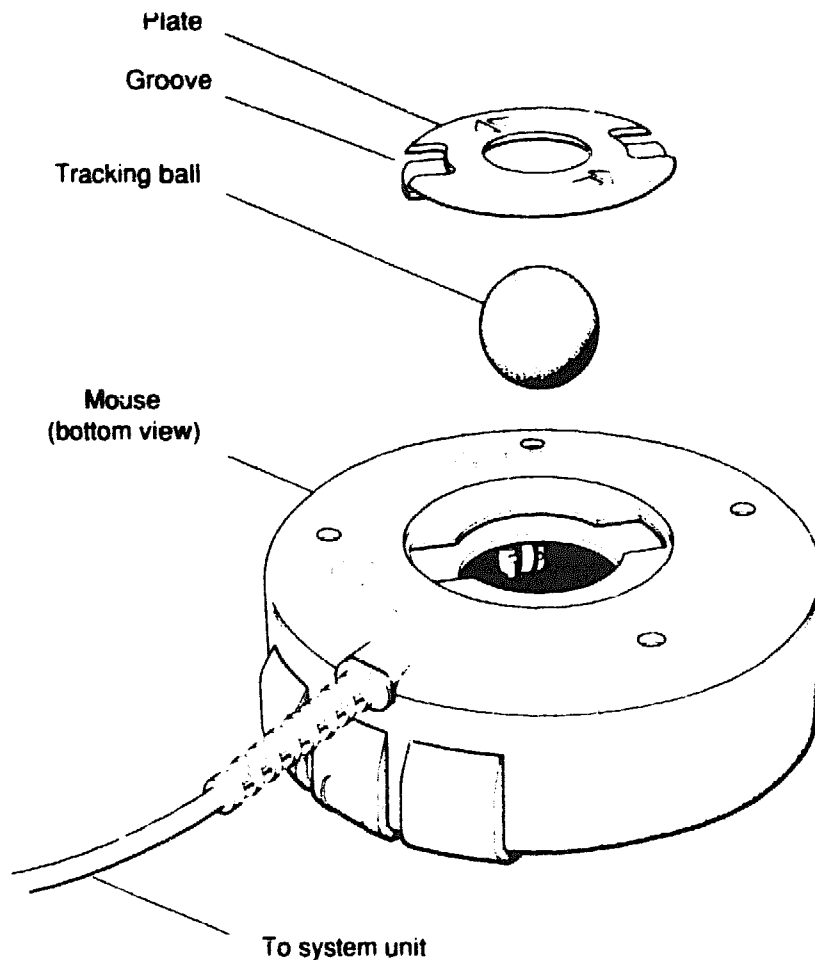

DEPG016

Figure 1-12. Removing the tracking ball from the mouse

4. Wash the ball with lukewarm water and, if necessary, mild soap.

Caution: Organic solvents, such as toluene or trichlorethane, damage the rubber coating.

5. Dry the ball with a soft, lint-free cloth.
6. Replace the ball by reversing steps 3 and 2.

Hardware Options

This chapter tells you

- What memory and storage options are available for the DECstation 2100/3100 workstation and how to get them installed
- What printers and modems are available for your system and where to learn how to install them

Adding Memory

You can add 4-megabyte memory modules to your system unit up to a total of 24 megabytes of memory.

To determine how much memory you can add, use the configuration display described in Chapter 3 of this guide.

To Add Memory Modules

To add memory modules, contact your Digital service representative, who will install them for you.

Adding Storage

Storage devices available for your DECstation 2100/3100 workstation include the following:

- 104-megabyte RZ23 internal hard disk drive
- 121-megabyte RZ23L internal hard disk drive
- 209-megabyte RZ24 internal hard disk drive
- 1.44-megabyte RX23 internal diskette drive
- 635-megabyte RRD40 external optical compact disc drive
- 332-megabyte RZ55 external hard disk drive
- 95-megabyte TK50Z external tape drive
- 1.2-gigabyte TLZ04 external cassette tape drive
- 2.2-gigabyte TKZ08 external tape drive

External devices come preinstalled in expansion boxes (see Figure 2-1).

External storage devices can also come preinstalled in the BA42 storage expansion box. This box can house up to two hard disk drives or one hard disk drive and one floppy disk or tape drive. The following storage devices are available:

- 332-megabyte RZ55 hard disk drive
- 655-megabyte RZ56 hard disk drive
- 1.0 gigabyte RZ57 hard disk drives
- 95-megabyte TZ30 tape drive
- 1.44-megabyte RX23 diskette drive
- 1.2-megabyte RX33 diskette drive
- 320-megabyte TZK10 QIC tape drive

Your workstation can have up to six such storage devices, including one or two internal hard disk drives and up to four external devices.

RRD40 optical
compact disc drive
expansion box

TLZ04 tape drive
expansion box

TK50Z tape drive
expansion box

BA42 storage
expansion box

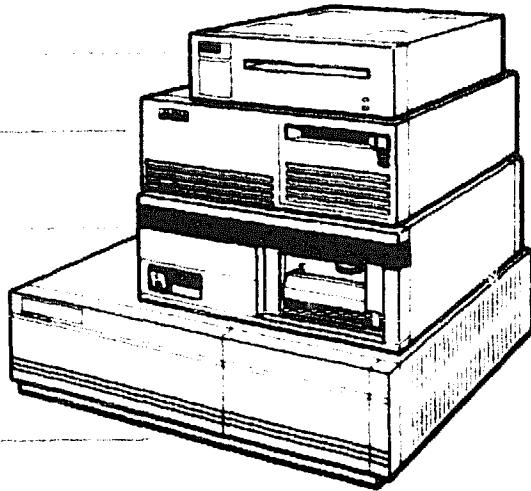

WSE20017

Figure 2-1. Expansion boxes

Internal Storage Devices

To add internal storage devices, contact your Digital service representative, who will install them for you.

External Storage Devices

To install external storage devices, follow the instructions in Chapter 4 of the *DECstation 2100/3100 Hardware Installation Guide*, which came in your DECstation 2100/3100 documentation kit.

Adding a Printer

Printers available for the DECstation 2100/3100 workstation include the following:

LN03 — A desktop, nonimpact laser printer that produces letter-quality text at a rate of eight pages per minute

LN03 Plus — An enhanced LN03 printer that prints documents with both text and graphics

LN03R Script Printer — A nonimpact page printer that uses laser recording technology to produce high-quality text, graphics, and images

LA100 — A desktop dot-matrix printing terminal

LA75 — A desktop dot-matrix printer with pixel graphics

LA50 — A desktop dot-matrix printer with bitmap or character-cell graphics

LJ250 color — A desktop dot-matrix color printer

LPS20 — A networked printer that functions as an independent system (or node) in a network

LPS40 — A networked printer that functions as an independent system (or node) in a network

When you order a printer, you may need to order a serial line cable to connect it to your system unit. Your Digital sales representative can tell you what you need.

To Add a Printer

For instructions on installing a printer, see Chapter 4 of the *DECstation 2100/3100 Hardware Installation Guide*, which came in your DECstation 2100/3100 documentation kit.

Adding a Modem

Modems available for the DECstation 2100/3100 workstation include the following:

DF242 Scholar Plus — A 300/1,200/2,400-bits-per-second, full-duplex asynchronous modem

DF224 — A 300/1,200/2,400-bits-per-second, full-duplex asynchronous modem

DF212 — A 300/600/1,200-bits-per-second, full-duplex asynchronous modem

DF112 — A 300/1,200-bits-per-second, full-duplex asynchronous modem

DF03 — A 300/1,200-bits-per-second, full-duplex asynchronous modem

Other modems that can be used are described in your software documentation.

When you order your modem, you may need to order a serial line cable with which to connect your modem cable to your system unit. Your Digital sales representative can tell you what you need.

Note: Auto-answer is not available; data leads only are connected.

To Add a Modem

For instructions on installing a modem, see the section on installing communication devices in Chapter 4 of the *DECstation 2100/3100 Hardware Installation Guide*, which came in your DECstation 2100/3100 documentation kit.

Using DECstation 2100/3100 Hardware

This chapter tells you

- How to turn your workstation on and off
- How to interpret and use the configuration display
- About some console commands you might find useful

Turning On Your Workstation

For a Workstation on a Power Strip

Turn on the power strip by pressing the raised portion of its on/off switch.

As soon as you turn on the power strip, the following things happen:

- The system unit begins its power-up self-test.
- The power indicator lights on your equipment glow green.

The monitor warms up, and a display similar to the following gradually appears on the screen:

```
KN01 V6.71
7..6..5..4..3..2..1..0
16Mb.....0
```

When testing has been completed successfully, a display similar to the following appears at the bottom of the screen:

```
KN01 V6.71
08-00-2b-0d-f7-6a
0x01000000
>>
```

The >> at the end of this display is the console program prompt. The console program is discussed later in this chapter and in Appendix C.

If the power-up self-test display fails to appear, or if the following line flashes on your screen, turn to Chapter 7 of this guide for troubleshooting instructions.

```
FAILURE - RESET TO CONTINUE
```

For a Workstation Not on a Power Strip

1. If you have an expansion box, turn it on by pressing the 1 on the on/off switch on the front of the box.
2. Turn on any printer and modem or other communications device by following the instructions that came with it.
3. Turn on the monitor.
 - On a VR150 monochrome or color monitor, press the on/off switch in the lower-right corner of the front of the monitor.
 - On a VR160 monochrome monitor, press the 1 on the on/off switch on the back of the monitor.
 - On a VR297 color monitor, press the 1 on the on/off switch on the front of the monitor.
 - On a VR262 or a VR299 color monitor, press the on/off switch on the right side of the monitor as you face the screen.

Note: After you turn the monitor on for the first time, you use the on/off switch on the system unit to turn the system unit and monitor on and off.

4. Turn on the system unit by pressing the 1 on the on/off switch on the back of the unit.

As soon as you turn on the system unit, the following things happen:

- The system unit begins its power-up self-test.
- The power indicator lights on your equipment glow green.

After about a minute, a display similar to the following gradually appears on the screen.

```
KN01 V6.71
7..6..5..4..3..2..1..0
16Mb.....0
```

When testing has been completed successfully, a display similar to the following appears at the bottom of the screen:

```
KN01 V6.71  
08-00-2b-0d-f7-6a  
0x01000000  
>>
```

The >> at the end of this display is the console program prompt. The console program is discussed later in this chapter and in Appendix C.

If the power-up self-test display fails to appear, or if the following line flashes on your screen, turn to Chapter 7 of this guide for troubleshooting instructions.

```
FAILURE - RESET TO CONTINUE
```

Turning Off Your Workstation

For a Workstation on a Power Strip

1. Shut down your operating system by following the instructions in your operating system software documentation.
2. Turn off the power strip by pressing the raised portion of its on/off switch.

For a Workstation Not on a Power Strip

1. Shut down your operating system by following the instructions in your operating system software documentation.
2. Turn off any printer and modem or other communications device by following the instructions that came with it.
3. If you have an expansion box, turn it off by pressing the 0 on the on/off switch on the box.
4. Turn off the system unit and monitor by pressing the 0 on the on/off switch on the back of the system unit.

Using the Configuration Display

The configuration display tells you

- How much memory your workstation contains
- Whether your monitor is monochrome or color
- What your Ethernet station address is (you must know this to be able to connect your workstation to a network)
- What storage devices your system has and what units they are assigned to

To Display Your Workstation Configuration

Type **test -c** at the console prompt (>>) and press Return.

A display similar to the following appears on your screen.

```
MEM: 16Mbytes
VIDEO: MONO
ETHERNET STA ADDR: 08-00-2b-0c-4a-8b
SCSI DEVS:
U[7]
U[6]KN01--SII
U[5]
U[4]
U[3] Dev typ 0 RZ
      RMB                0x0
      Vrs                 1
      Format               1 CCS
      Add len              31
      Vndr                 DEC
      PID                  RZ23      (C) DEC
      Frevlvl              0618
U[2]
U[1]
U[0]
```

Figure 3-1. Sample configuration display

From this display, you learn the following:

Line 1 — Tells you how much memory you have in your system. The system described in the figure has 16 megabytes of memory. You could add one or two 4-megabyte memory modules to this system.

Line 2 — Tells you what kind of monitor you have. The system described in the figure uses a monochrome monitor. If it had a color monitor, this line would read `COLOR`.

Line 3 — Tells you your Ethernet station address. The address for the system described in the figure is 08-00-2b-0c-4a-8b. You need to know your Ethernet address if you want to be able to connect your workstation to a network.

Line 4 — Introduces the list of small computer system interface (SCSI) device locations available in your system. The remaining lines of this display describe any SCSI devices assigned to units 7 through 0.

Line 5 — Tells you that the system described in the figure has nothing assigned to unit 7. Leave this unit empty. Assigning a storage device to unit 7 can cause the system to malfunction.

Line 6 — Tells you that unit 6 contains the controller that directs the operation of your SCSI devices.

Lines 7, 8 — Tells you that the system described in the figure has nothing assigned to units 5 and 4. You could add storage devices here.

Line 9 — The system in the figure has a hard disk drive assigned to unit 3. The words `Device type 0 DISK` appear on the unit-number line for any unit that contains a hard disk drive or a diskette drive. If unit 3 contained a tape drive or a cassette tape drive, the words `Device type 1 TAPE` would appear on the unit-number line. If unit 3 contained an optical compact disc drive, the words `Device type ROM DISK` would appear on the unit number line.

Lines 10-16 — Describes the device assigned to unit 3 in more detail. This type of description is displayed for any SCSI device connected to your system. In the example, line 16, column 2 reads RZ23 for an RZ23 internal hard disk drive.

Lines 17, 18, 19 — The system described in the figure has no devices assigned to units 2, 1, and 0. You could add storage devices here.

Using Console Commands

By typing commands, called console commands, at the console prompt (>>), you can gather some important information about your workstation hardware.

Many of the console commands are used for diagnostic testing and debugging by Digital service personnel. However, you may find the commands described here useful to know.

Important: *All commands typed at the console level are case sensitive. The workstation does not recognize uppercase and lowercase letters as the same input.*

help	Displays the list of console commands and tells how to issue them.
?	Displays the list of console commands and tells how to issue them.
init	Performs a full initialization of your system.
printenv	Displays the environment variables. This display contains a list of variables, such as the baud rate for your communications devices, and gives the current value for each variable.
test -a	Runs the workstation's hardware self-test.
test -c	Runs the configuration test and displays your current configuration.

For a more extensive list of console commands, see Appendix C of this guide.

Booting the Worksystem Software

When you boot your worksystem software, you load your software onto your system so that you can work with your system. When you boot successfully, your workstation prompts you for your username.

- To boot from the console program to a normal time-sharing environment, enter **auto** at the console prompt (>>).
- To boot from the console program to single-user mode, enter **boot** at the console prompt (>>).
- To boot from the console program to single-user mode using software on a network server, enter **boot -f mop()** at the console prompt (>>).

Booting a standalone workstation from disk takes approximately 3 minutes. If you boot the operating system successfully, the workstation prompts you to log on.

If the workstation does not boot successfully, contact your system manager.

Setting the Workstation for Automatic Booting

To set the workstation for automatic booting, use the **setenv** console command. Enter **setenv bootmode a** at the console prompt (>>).

The workstation automatically boots, using the file designated in the **bootpath** variable, each time power is turned on.

For a discussion of the **setenv** command, see Appendix C of this guide.

If the workstation does not boot successfully, contact your system manager.

Shutting Down the Worksystem Software

When you want to shut down the worksystem software, contact your system manager or consult the documentation that came with your worksystem software. The commands you use to shut down your worksystem software are described in Table 3-1.

Table 3-1. Shutdown Commands

Command	Result
<code>/etc/shutdown -h now</code>	Starts the operating system shutdown procedure immediately, without issuing warning messages.
<code>/etc/shutdown -h HHMM</code>	Shuts down the operating system at a specified time. In this table, HH indicates hours and MM indicates minutes. The workstation sends warning messages to all users on the local area network (LAN) indicating shutdown time.
<code>/etc/shutdown -h +N</code>	Shuts down the operating system after a specified number of minutes. In this table, N indicates the number of minutes after which the operating system shuts down. The workstation sends warning messages to all users on the LAN at an increasing frequency as shutdown time approaches.

Using Tape Drives

This chapter tells you how to use a TK50Z external tape drive. For instructions on using the TLZ04 cassette tape drive or the TKZ08 tape drive, see the owner's manual that came with that drive. For instructions on using the TZ30 tape drive, see the *BA42 Storage Expansion Box Installation Guide*.

The optional TK50Z tape drive can store 95 megabytes of data on each of its tape cartridges. Its function is to read and write data to and from the magnetic tape in a cartridge.

The cartridges for your tape drive contain magnetic tape on a single reel. The top of each cartridge carries the label "CompacTape."

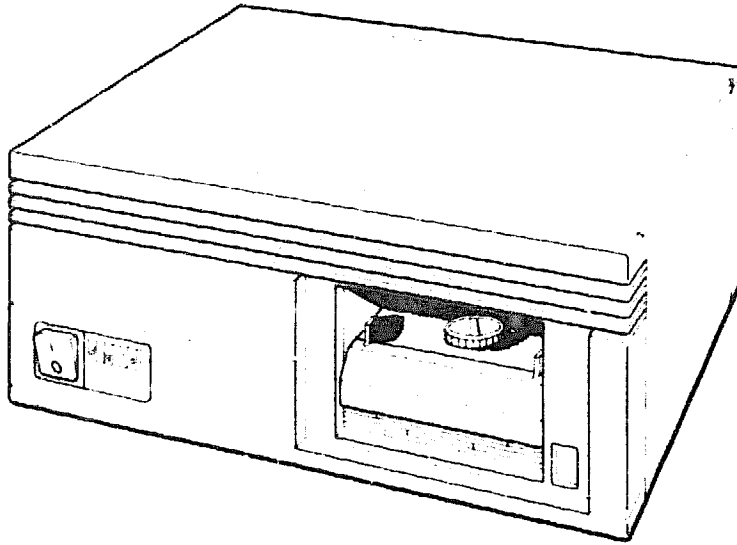

DEPG034

Figure 4-1. The tape drive

Checking the Position of the Tape Leader Inside a Cartridge

The magnetic tape inside a cartridge begins with a plastic leader. When the cartridge is inserted into a tape drive, a take-up leader inside the drive mates with the leader on the tape. This take-up leader draws the tape out of the cartridge and onto the take-up reel inside the tape drive.

Before using a cartridge, check the position of the leader inside it to make sure it is correct.

1. Remove the cartridge from its protective case.
2. Open the door on the back of the cartridge.
 - a. Insert your thumb into the groove on the right corner of the back of the cartridge.
 - b. Press up on the door lock to release it.
 - c. Push the right edge of the door away from you until the door is fully open and you can see the leader.

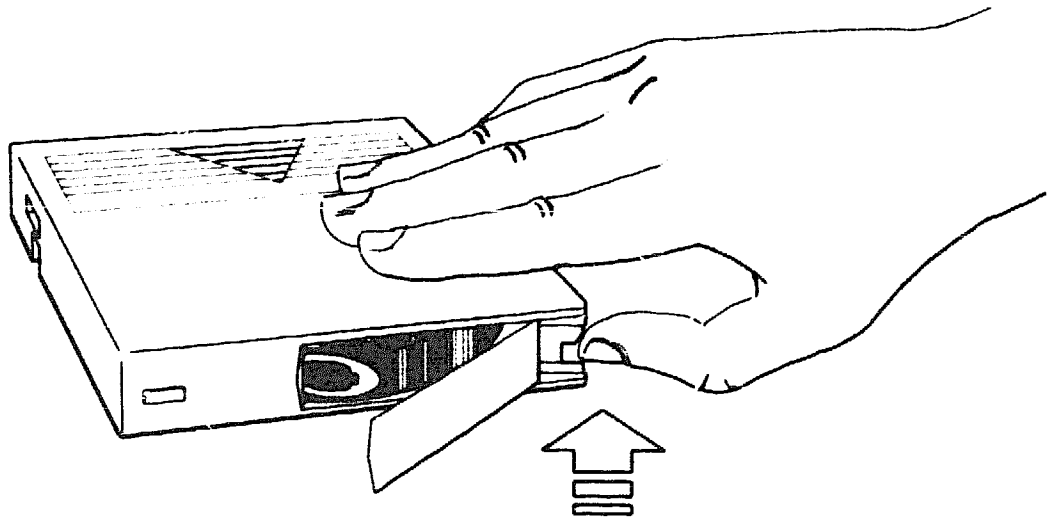

DEPG009

Figure 4-2. Opening the door on the cartridge

3. Be sure the leader is positioned as shown in Figure 4-3. If it looks different in any way, use another cartridge.

Caution: *Using a cartridge that has an incorrectly positioned leader can damage your tape drive.*

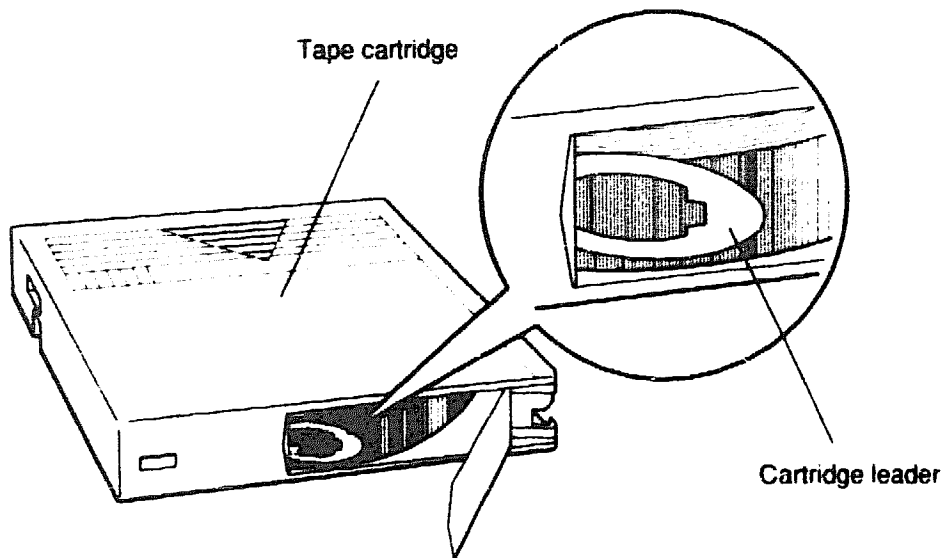

DEPG010

Figure 4-3. A tape leader positioned correctly in the cartridge

Write-Protecting a Cartridge

To prevent information on the tape from being written over, write-protect the cartridge. Do this when you use your drive to read software or data from the tape.

To write-protect a cartridge,

1. Find the write-protect switch on the right side of the front of the cartridge.
2. Slide the switch to the left until an orange dot appears above the left arrow on the switch.

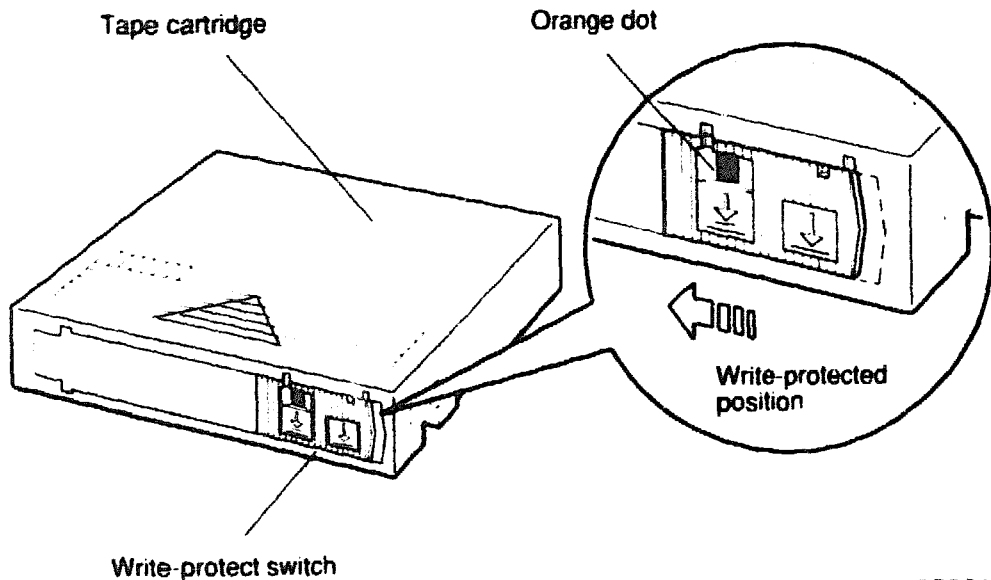

DEPG011

Figure 4-4. A write-protected cartridge

Write-Enabling a Cartridge

When you want to write data to a cartridge, write-enable it. Do this when you want to use your drive as a backup device.

To write-enable a cartridge,

1. Find the write-protect switch on the right side of the front of the cartridge.
2. Slide the switch all the way to the right until the orange dot disappears.

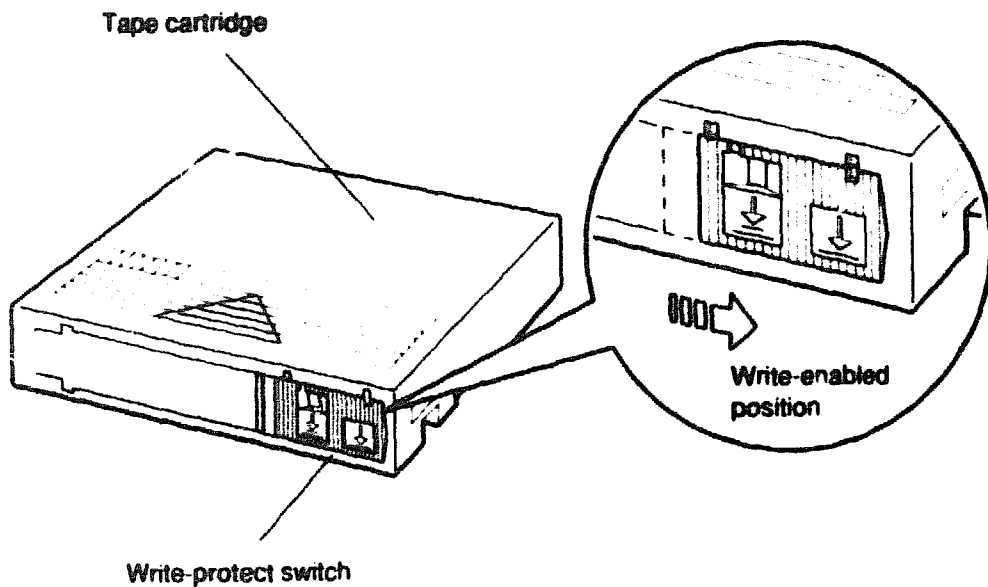

DEPG012

Figure 4-5. A write-enabled cartridge

Checking the Take-Up Leader Inside the Drive

The take-up leader inside the drive must be in the correct position for it to mate with the tape cartridge leader.

Caution: Trying to use a tape drive when the take-up leader is not in the correct position can damage the drive.

1. Find the cartridge insert/release handle on the front of the expansion box.
2. Press the handle down until you can see the leader inside the drive.
3. Be sure the leader is positioned as shown in Figure 4-3.

If the leader is not positioned correctly, call your Digital service representative.

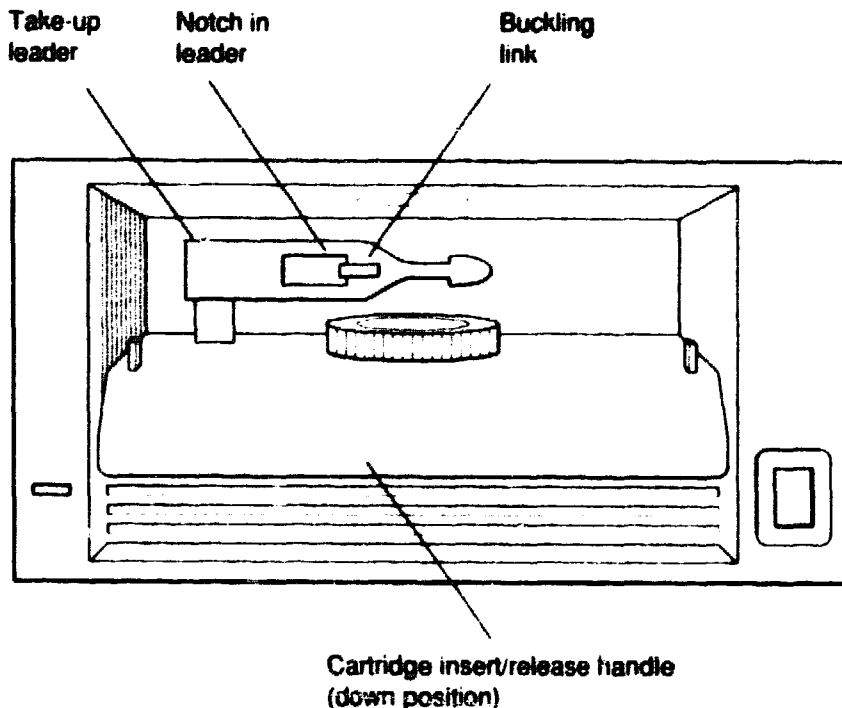

DEPG013

Figure 4-6. A take-up leader: positioned correctly in the drive

Loading a Tape Cartridge

When you load a cartridge, the tape automatically threads onto the reel inside the drive.

1. Turn on the drive by pressing the 1 on the on/off switch on the front of the drive.

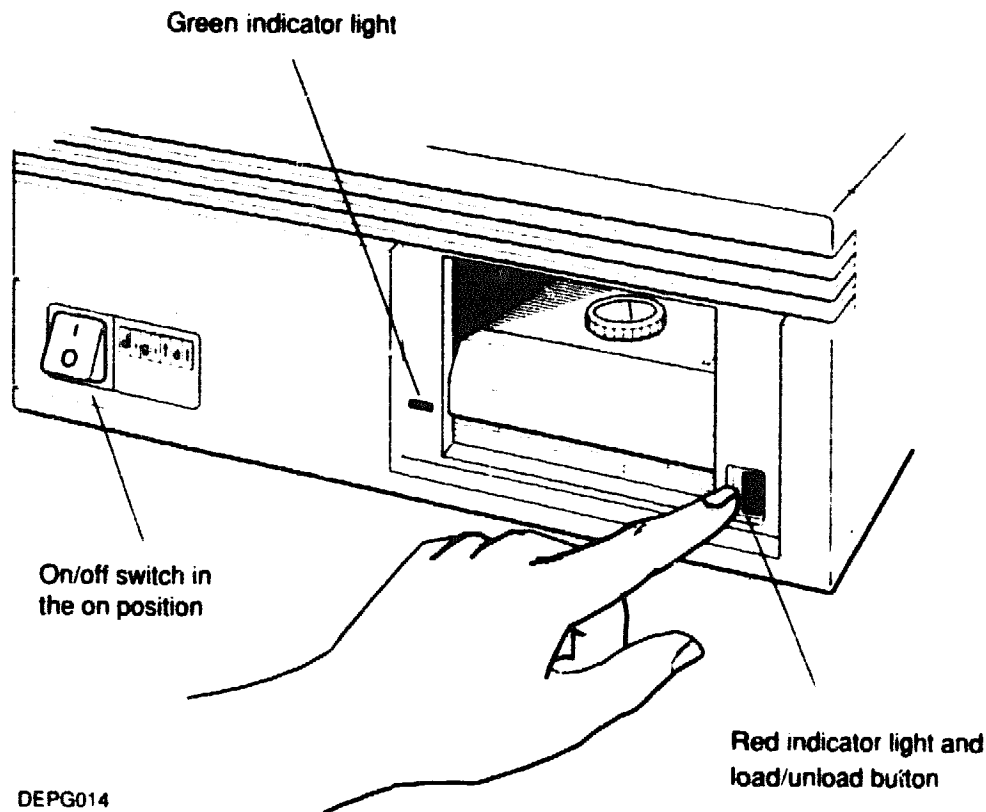

DEPG014

Figure 4-7. Pressing the load/unload button on a tape drive

2. Press and release the load/unload button on the front of the expansion box until it pops into the unload (out) position.

The red light in the lower-right corner of the front of the box glows for 5 to 15 seconds while the drive runs its self-test.

If the self-test fails, or if there is any problem with the drive, the red light blinks rapidly.

If this occurs, stop using the drive and refer to Chapter 7 of this guide for troubleshooting procedures or call your system manager or Digital service representative for help.

3. When the red light goes out and the green light in the lower-left corner glows, lift the cartridge insert/release handle to open the drive door.

Caution: *Lifting the insert/release handle while the red light glows or blinks can damage the tape and the drive.*

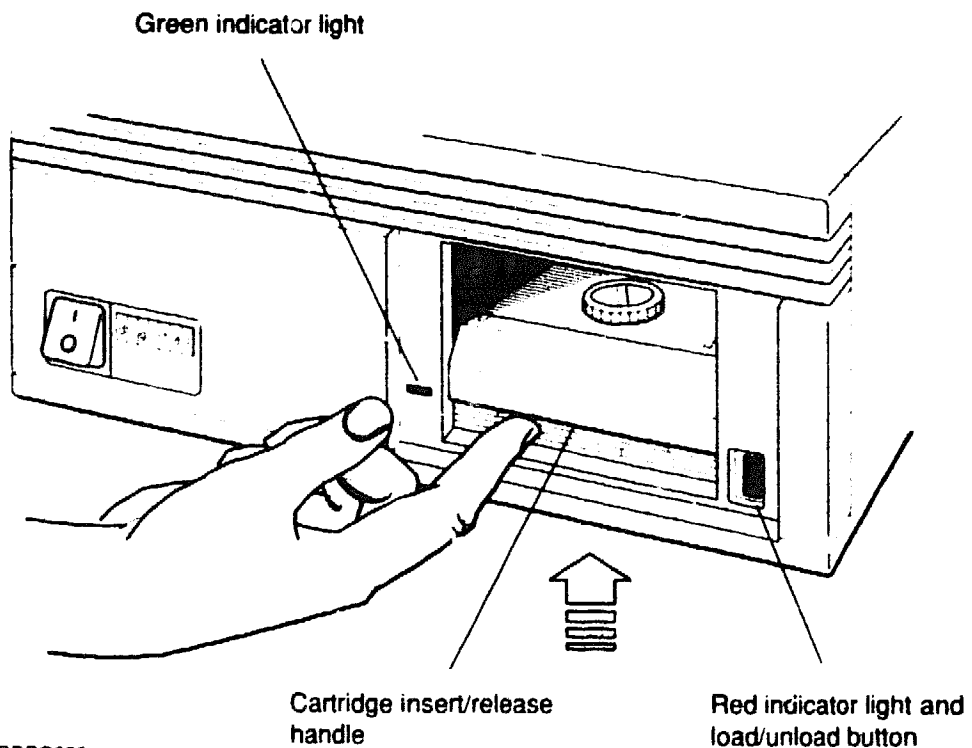

DEPG029

Figure 4-8. Lifting the insert/release handle on a tape drive

4. Position the cartridge so the arrow is on top and pointing away from you and the write-protect switch faces you.
5. Place the cartridge part way into the drive.

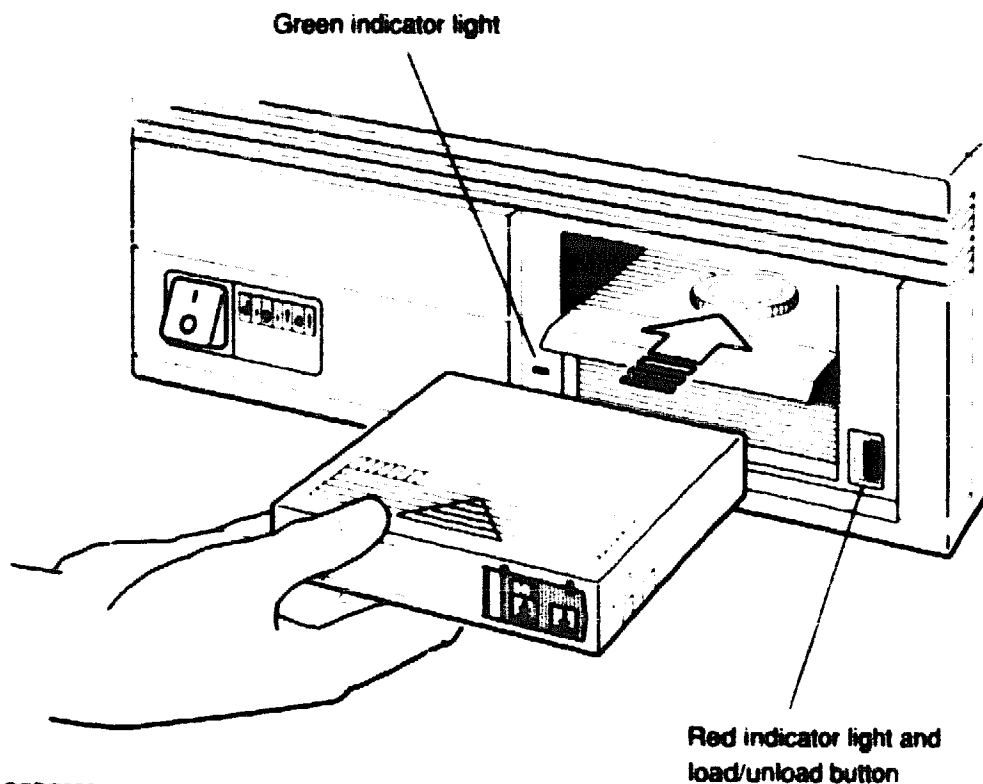

DEPG026

Figure 4-9. Inserting a tape drive

6. When you begin to feel resistance, push the cartridge firmly and smoothly into the drive until it locks into place.
The green light turns off and the red light glows.

7. Lower the insert/release handle to close the drive door, as shown in Figure 4-10.
8. Wait for the red light to turn off and the green light to glow.
9. Press the load/unload button until it locks into the load (in) position.

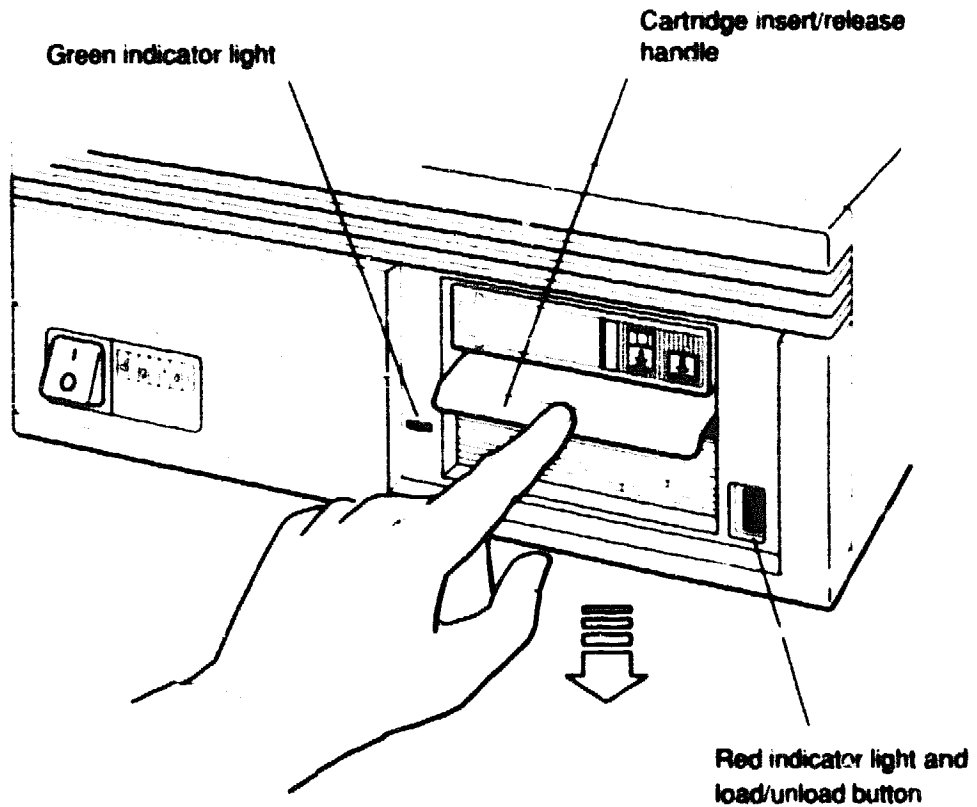

DEPG028

Figure 4-10. Lowering the insert/release handle on a tape drive

10. **Begin to use the cartridge when the red and green lights both glow steadily.**

As you use the cartridge, you will notice the following:

- **The green light blinks while the red light glows during normal system operation.**
- **Both the red and green lights blink while the tape rewinds.**
- **The green light turns off and the red light blinks rapidly when a problem occurs.**

If this happens, see Chapter 7 of this guide for troubleshooting procedures or call your system manager or Digital service representative for help.

Removing a Tape Cartridge

Before you remove a cartridge, the tape must be fully rewound. This process can take up to 90 seconds. Rewinding occurs automatically when you attempt to remove the cartridge.

1. Press and release the load/unload button on the front of the expansion box until it pops out into the unload position.

If any tape must be rewound, the red and green lights blink slowly while rewinding is in process.

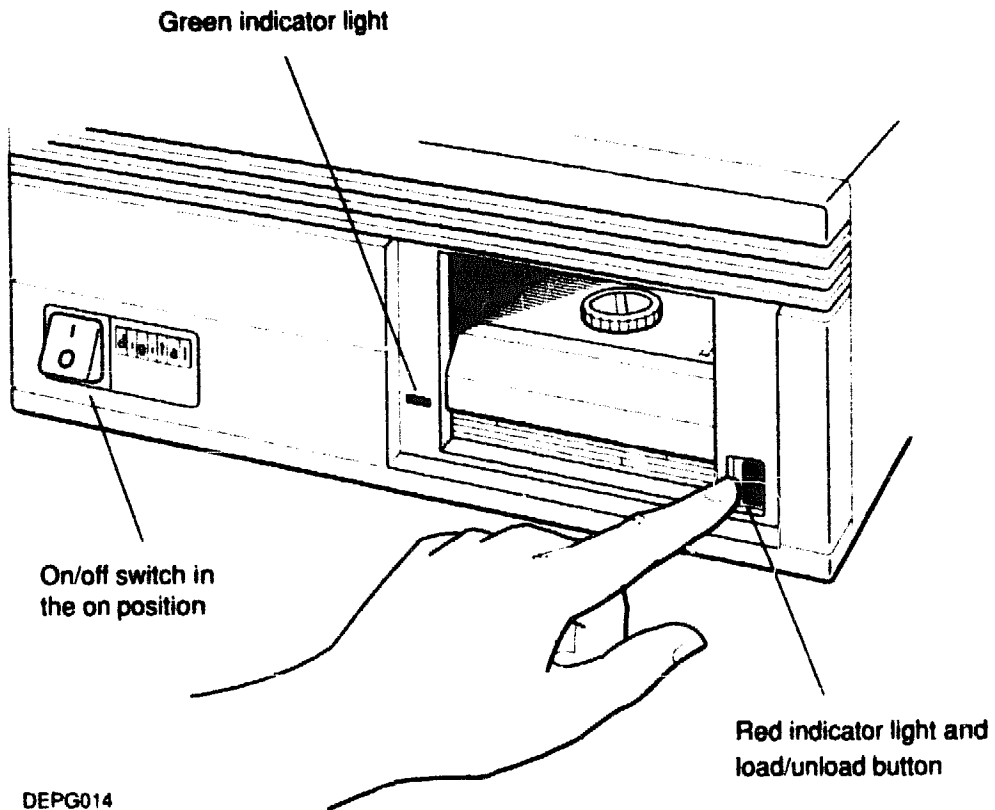

Figure 4-11. Pressing the load/unload button on a tape drive

2. Wait 8 to 10 seconds for the tape to unload after rewinding is complete.
 - The red light glows steadily while the tape unloads.
 - When the red light turns off and the green light glows, you can remove the cartridge.
3. Lift the insert/release handle on the front of the expansion box to partially eject the tape.

Caution: *Lifting the insert/release handle while the red light glows or blinks can damage the tape and drive.*

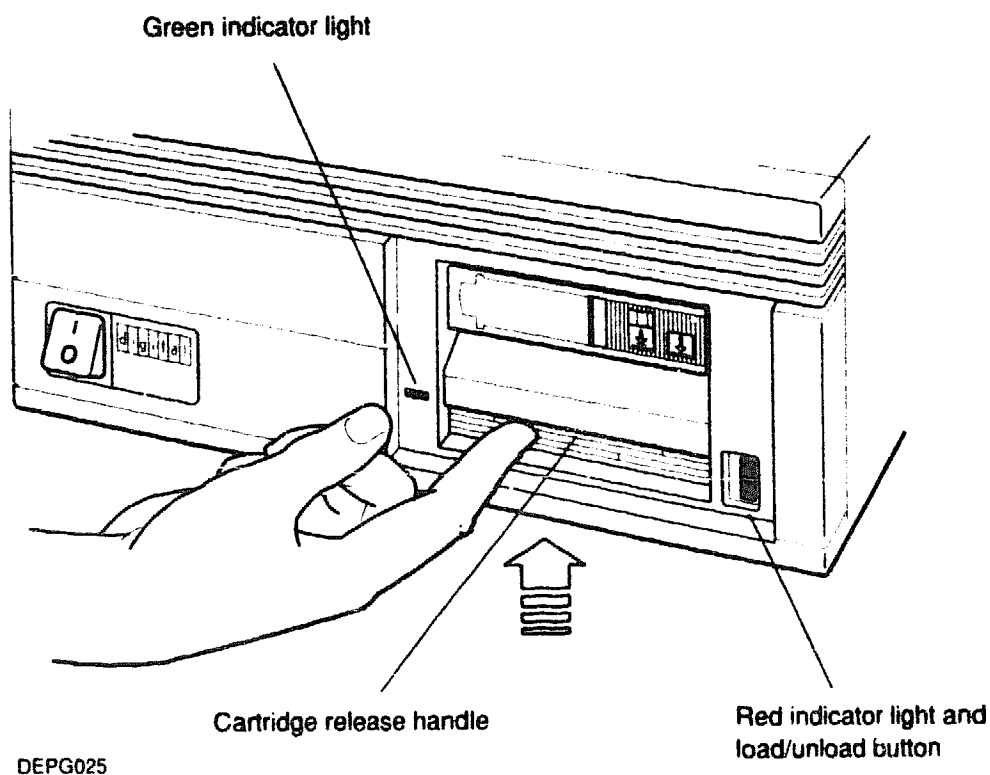
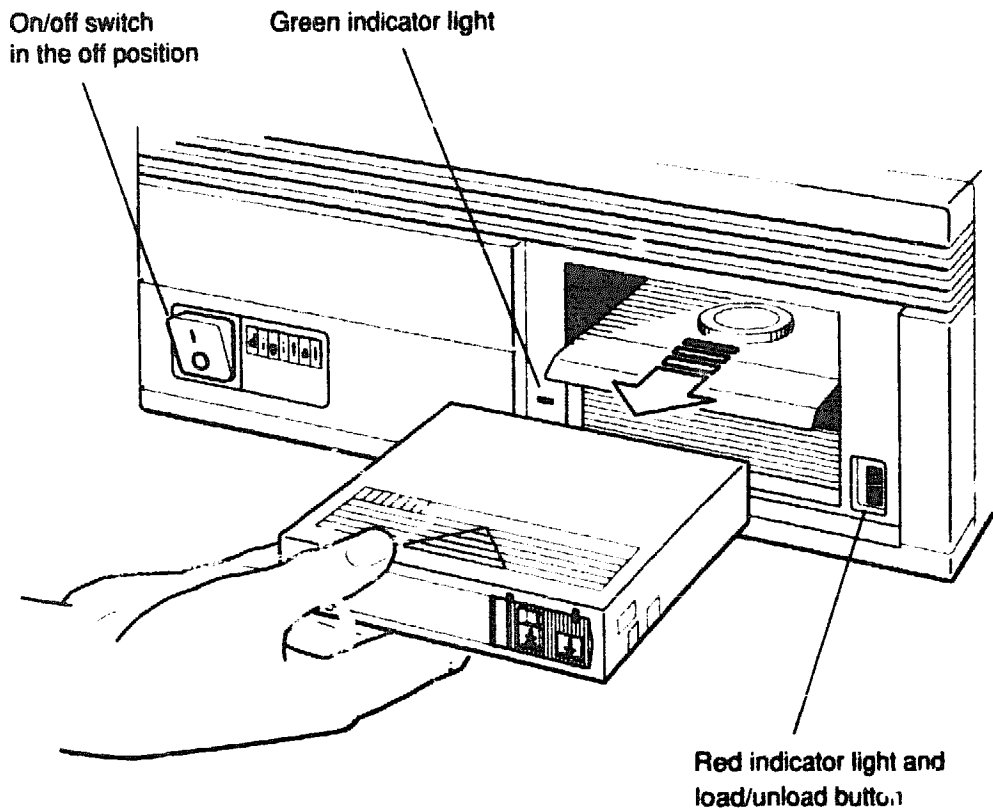

Figure 4-12. Lifting the insert/release handle on a tape drive

4. Pull the cartridge out of the drive, as shown in Figure 4-13, and return it to its protective case.
5. Press the 0 on the on/off switch to turn off the drive.



DEPG027

Figure 4-13. Removing a tape cartridge

Using an Optical Compact Disc Drive

This chapter tells you how to use an optical compact disc drive.

The disc drive is a read-only storage device that reads data from removable compact discs. Its uses include reading instructions during software installation and storing database data and online documentation.

The RRD40 optical compact disc drive, which can store up to 635 megabytes of data, comes preinstalled in an expansion box designed to sit on a desk or table.

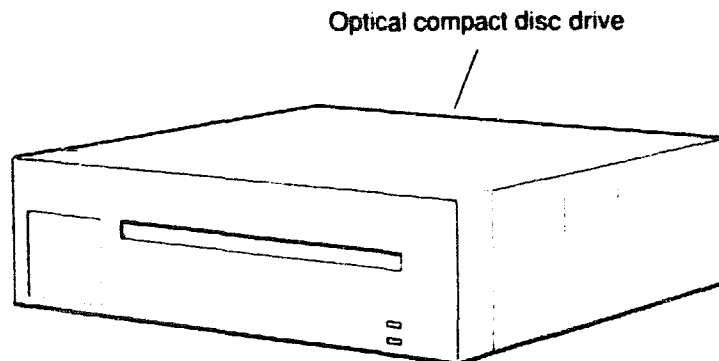

DEFO011

Figure 5-1. The optical compact disc drive

Connectors, Controls, and Indicator Lights on the Disc Drive

The optical compact disc drive has the controls, indicators, and connectors pictured in Figure 5-2 and described in Table 5-1.

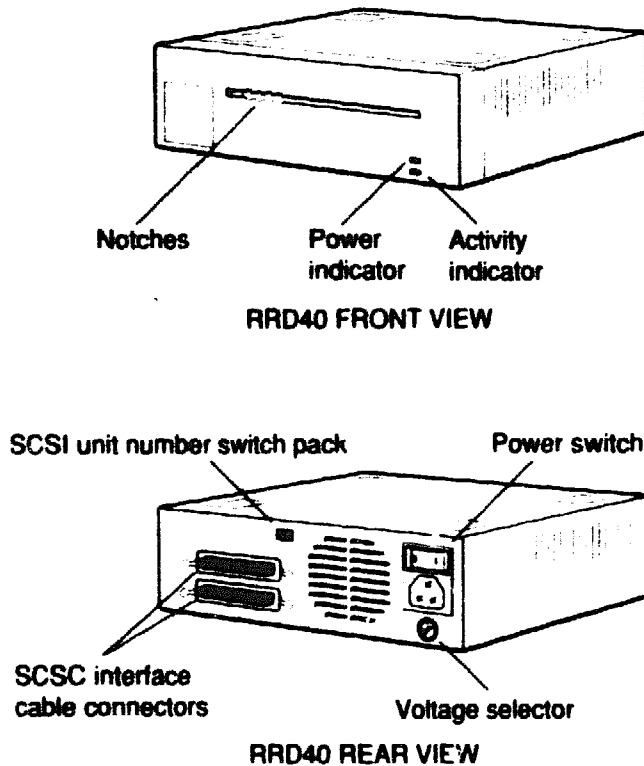

DEF1058

Figure 5-2. Connectors, controls, and indicator lights on the drive

Table 5-1. Connectors, Controls, and Indicator Lights on the Disc Drive

Item	Function
Power indicator light	Glows green to indicate the drive is receiving power.
Activity indicator light	Glows green to indicate a disc has been loaded into the drive; blinks while the disc transfers information.
Top cable connector	The point at which the disc drive connects to the system unit.
Bottom connector	Contains the small computer systems interface (SCSI) terminator that was removed from the system unit SCSI connector when the drive was connected to it.
SCSI switches	Allow you to set the SCSI address on your optical compact disc drive.
On/off switch	Turns the drive on and off. Pressing the 1 turns the drive on. Pressing the 0 turns it off.
Voltage-selection switch	Lets you match the drive's voltage to the voltage available at the power source.

Using an Optical Compact Disc Drive

An optical compact disc is one part of a three-part caddy that consists of the following:

- The disc
- A plastic frame that curves around the sides of the disc
- A transparent protective sleeve that covers the disc and frame

When the caddy is not in a drive, the frame surrounds the disc and is locked into place by a tab in each of the two corners of the frame. When you insert the caddy into a drive, the tabs unlock and the frame releases the disc. You then remove the sleeve from the drive.

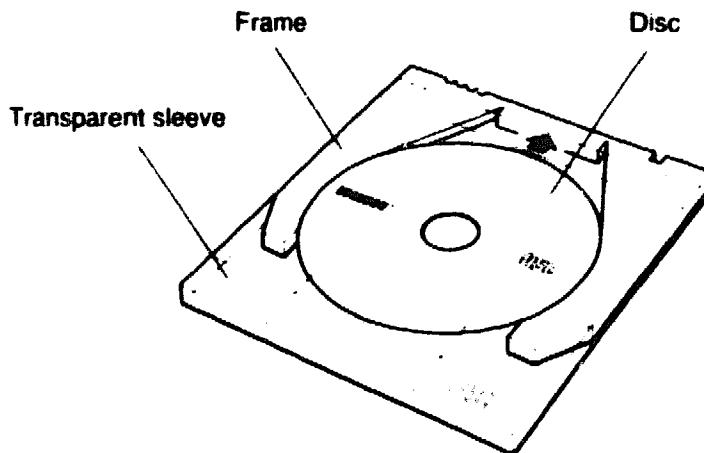

DEFO029

Figure 5-3. The parts of a disc caddy

To Load a Disc into a Drive

1. Look at the caddy carefully to be sure it is not damaged in any way.

Caution: Loading a cracked or otherwise damaged caddy into the drive can damage the disc and the drive.

2. Turn on the drive by pressing the 1 on the on/off switch on the back of the drive, as shown in Figure 5-4.
3. Be sure the power light in the lower-right corner of the front of the drive is glowing green.

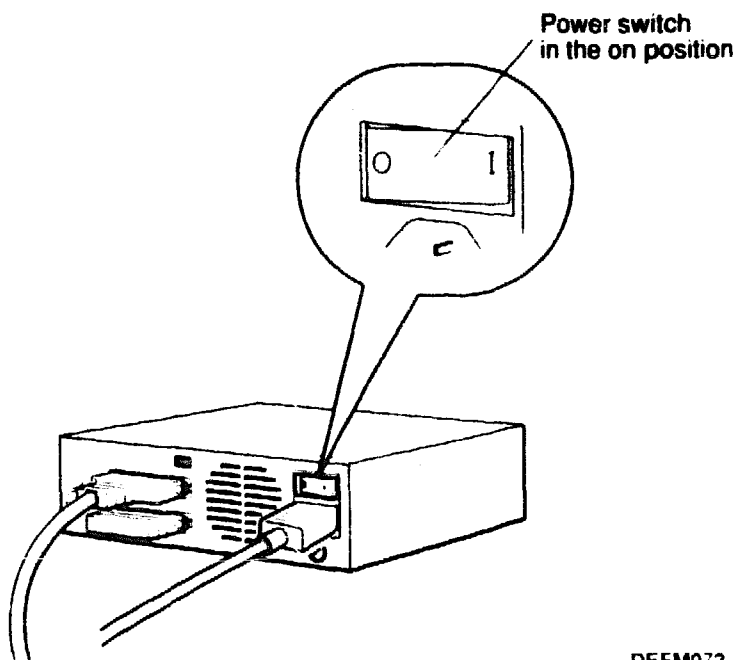

DEFM072

Figure 5-4. Turning on the drive

4. Position the caddy so that

- The hooked sides of the locking tabs face down
- The locking tabs face the door of the drive
- The label on the disc faces up
- The notches on the caddy are on the left and line up with the notches on the door of the drive

If any of these conditions cannot be met, the disc is positioned incorrectly in the caddy. Use another disc or refer to the discussions of unloading discs from and loading discs into caddies later in this chapter.

Caution: *Using a disc positioned incorrectly in its caddy can damage the disc.*

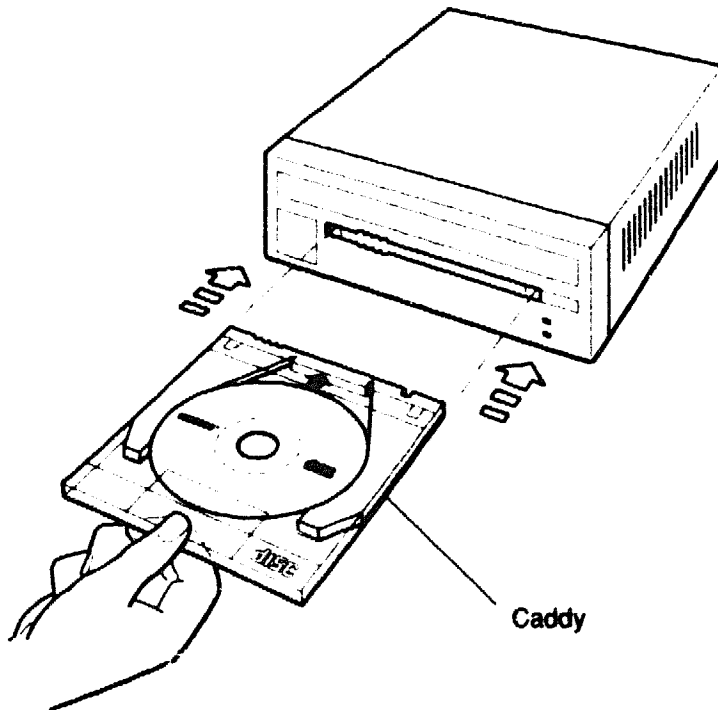

DEFO030

Figure 5-5. Positioning the caddy

5. Insert the caddy straight into the drive, sliding it in as far as it will go.

Caution: *Inserting a caddy at an angle can damage the drive.*

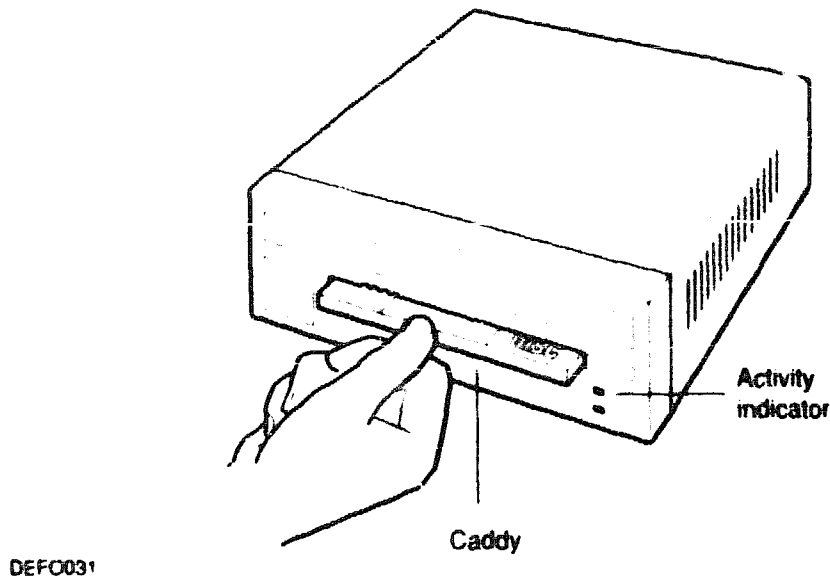

Figure 5-6. Inserting the caddy

6. Pull the protective sleeve out of the drive. The frame and the disc remain inside the drive.

Within 5 seconds, the green activity light begins to glow. If the light fails to glow, unload the disc, check to make sure it is positioned correctly, and insert it into the drive again.

If the activity light still fails to glow, contact your Digital service representative.

To Unload a Disc from a Drive

1. Be sure the green activity light glows steadily before you unload the disc. If the light blinks, the drive is transferring data. Wait until the blinking stops.
2. Position the protective sleeve so that
 - The open portion of the sleeve faces the drive door
 - The arrow on the sleeve faces up and points toward the drive door

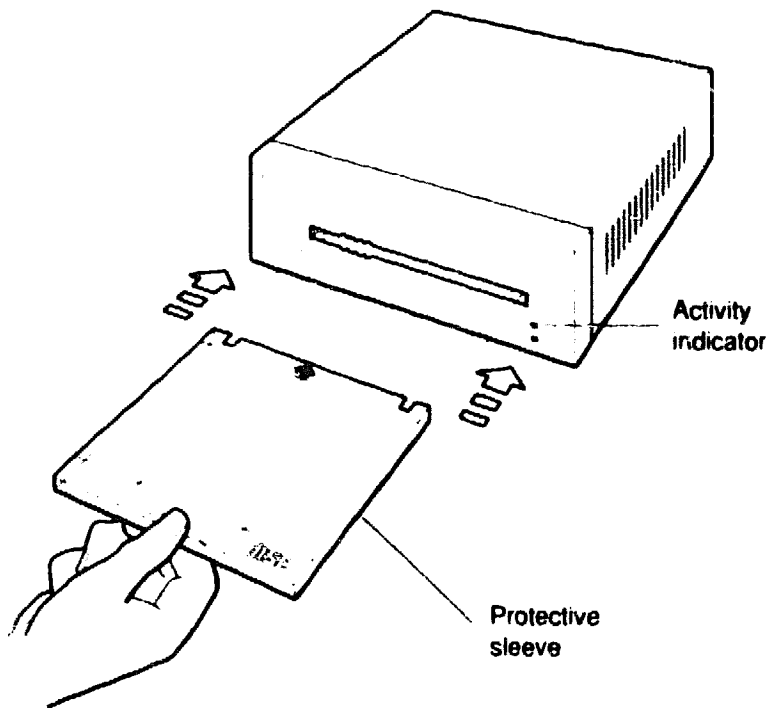

DEFO032

Figure 5-7. Positioning the protective sleeve

3. Insert the sleeve into the drive as far as it will go.

Caution: *Inserting the sleeve at an angle can damage the drive and the disc.*

4. Pull the caddy straight out of the drive. The disc and frame come out in the sleeve, and the green activity light goes out.

Handling Compact Discs

When handling a disc that is not in its caddy, work over a flat surface and position the disc with its label side down. This reduces the chances of damaging the data surface if you drop the disc.

Be careful not to touch the data side of the disc (the side without the label on it).

Caution: *Touching the data side of the disc when it is out of the caddy can cause tracking errors.*

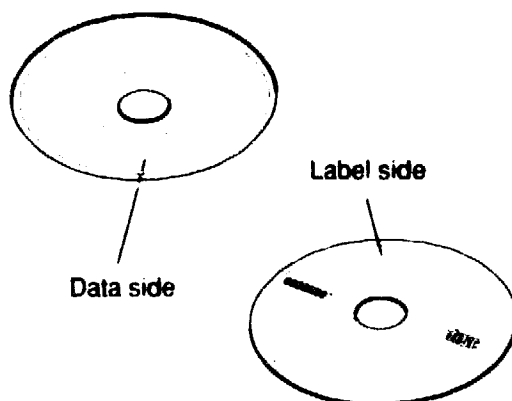

DEFO033

Figure 5-8. A compact disc

To Unload a Disc from Its Caddy

1. Position the caddy so the hooked sides of the frame-locking tabs face up.
2. Use the tip of a ballpoint pen, or some similar instrument, to press down on each tab while gently pulling the frame away from the sleeve.
3. Pull the frame a little way out of the sleeve.

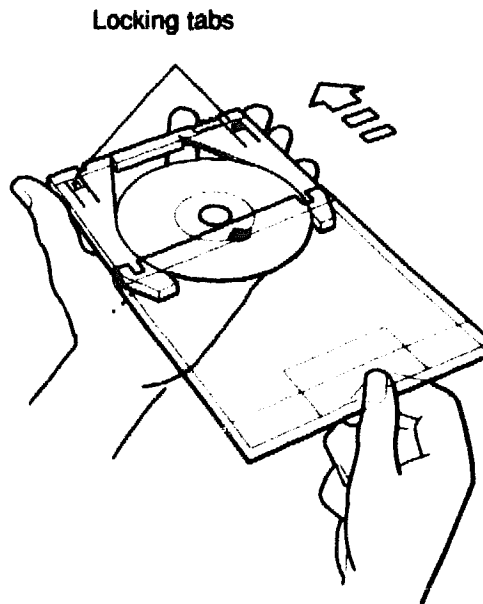

DEFO046

Figure 5-9. Beginning to remove the frame

4. Keeping continuous light pressure on the sides of the frame so it holds the disc firmly in place, completely remove the frame and disc from the sleeve. The disc is not locked in the frame; it is only the pressure of your hand that keeps it there.

Caution: *Releasing pressure on the sides of the frame allows the disc to drop out of the frame and can cause tracking errors.*

5. Place the index finger of your free hand in the hole in the disc and rest your thumb against the outer edge of the disc.

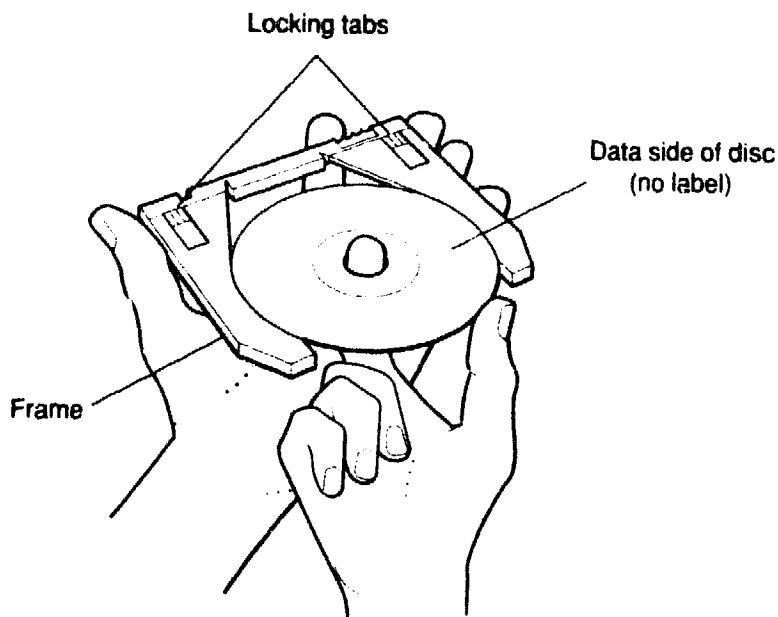

DEFO034

Figure 5-10. Holding the disc

6. Release the pressure you've been keeping on the frame and remove the disc from inside the frame.

To Load a Disc Into Its Caddy

1. Hold the disc with the index finger of one hand in the hole in the disc and the thumb of that hand resting against the side of the disc.
2. Position the disc so the data (unlabeled) side of the disc faces up.

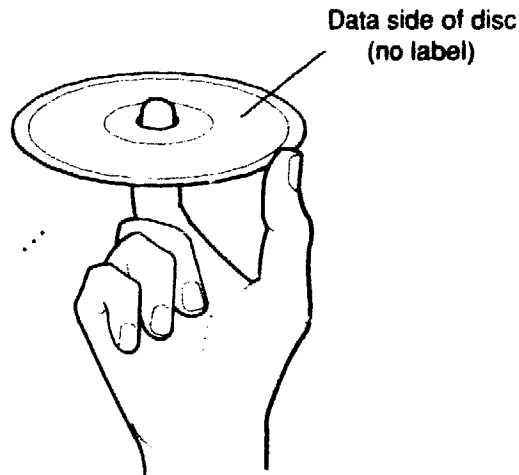

DEFO035

Figure 5-11. Positioning the disc

3. With the other hand, position the frame so the hooked sides of the locking tabs face up.

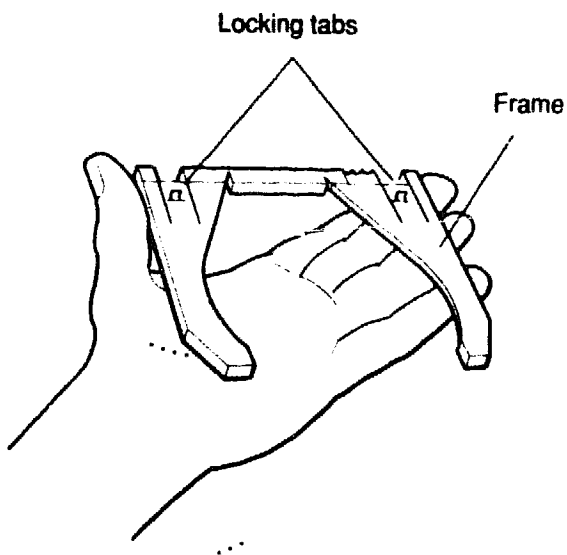

DEFO037

Figure 5-12. Positioning the frame

4. Place the disc inside the frame and press the sides of the frame firmly against the disc.

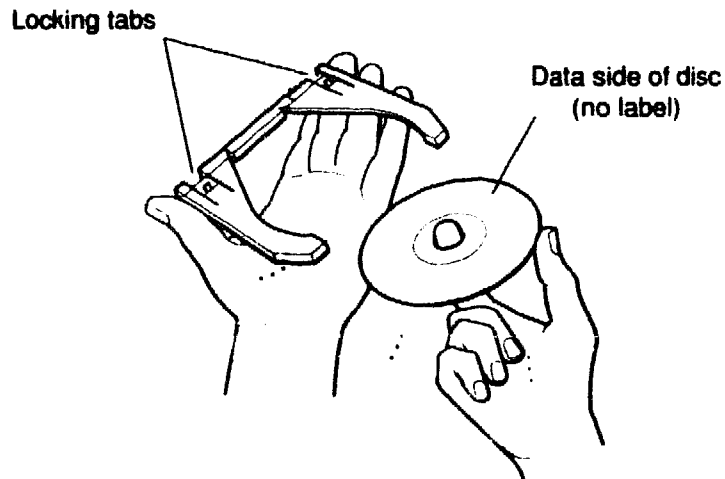

DEFO038

Figure 5-13. Placing the disc inside the frame

5. Insert the disc and frame into the sleeve until the locking tabs snap into place.

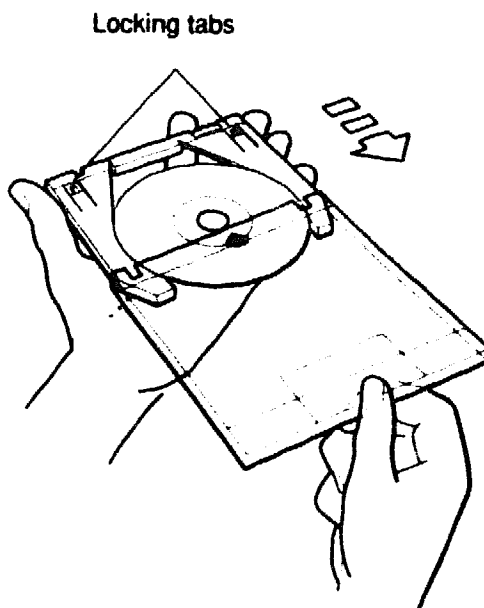

DEFO039

Figure 5-14. Inserting the disc and frame into the sleeve

Cleaning a Compact Disc

Tracking errors can develop when discs become dirty.

To clean a disc,

1. Remove the disc from its caddy, as described earlier in this chapter.
2. Hold the disc by its edges, with one finger in the hole in the center of the disc and your thumb resting against the side of the disc.
3. Use a dry, lint-free cloth to wipe the disc with small circular strokes, moving from the center of the disc out toward the rim.

Caution: *Using a continuous circular stroke around the disc can damage the disc.*

For Further Information

For a more detailed discussion of the RRD40 optical compact disc drive, see the *RRD40 Optical Disc Drive Owner's Manual*, which came with your drive.

Using the RX23 Diskette Drive

This chapter tells you how to use an internal diskette drive.

The optional RX23 diskette drive, shown in Figure 6-1, is located in the right front corner of the system unit.

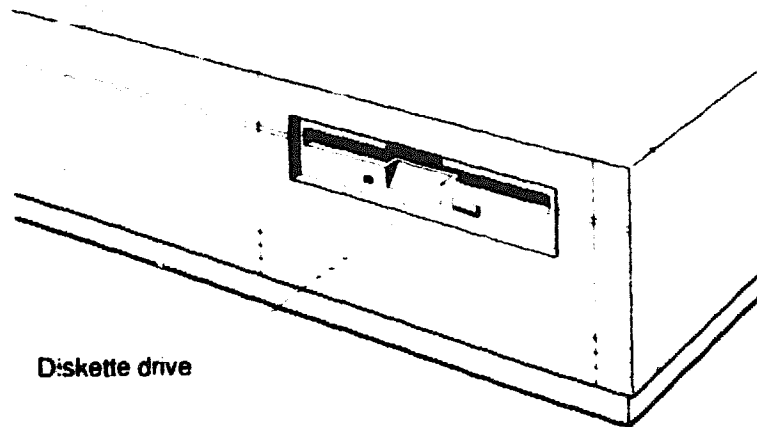

DERX034

Figure 6-1. The internal diskette drive

Use the diskette drive to read and write data to and from diskettes. You can store up to 1.44 megabytes of data on each formatted diskette.

The diskette drive requires high-density diskettes. You can identify high-density diskettes by the notches that appear in each lower corner of the diskette. A diskette that has a notch in only one corner is not a high-density diskette.

Digital recommends that you use RX23K diskettes. These diskettes carry the DIGITAL logo and the label RX23K on the metal portion of the front of the diskette.

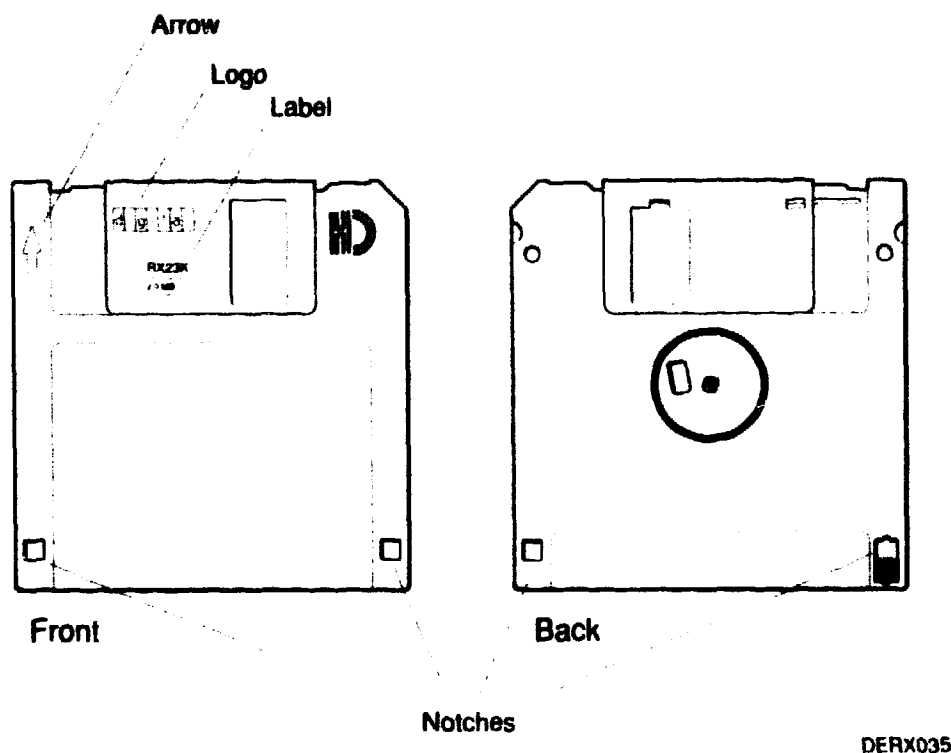

Figure 6-2. An RX23K diskette

Using Diskettes

When you use a diskette, it is always either write-protected or write-enabled.

- Write-protect a diskette to prevent the drive from writing over information already on the diskette.

Do this when you want to use your drive to read, but not write, software or data on the diskette.

- Write-enable a diskette when you want the drive to write data to the diskette.

Do this when your diskette holds data files you want to change.

You can tell whether a diskette is write-protected or write-enabled just by looking at it.

- A diskette is write-protected if a small, square opening appears in each corner of the bottom of the diskette.
- A diskette is write-enabled if there is an opening in only one corner of the bottom of the diskette.

To Write-Protect a Diskette

1. Find the black write-protect switch in the lower-right corner of the back of the diskette.
2. Move the switch toward the bottom of the diskette until it clicks and locks into place.

A small, square opening appears just above the switch.

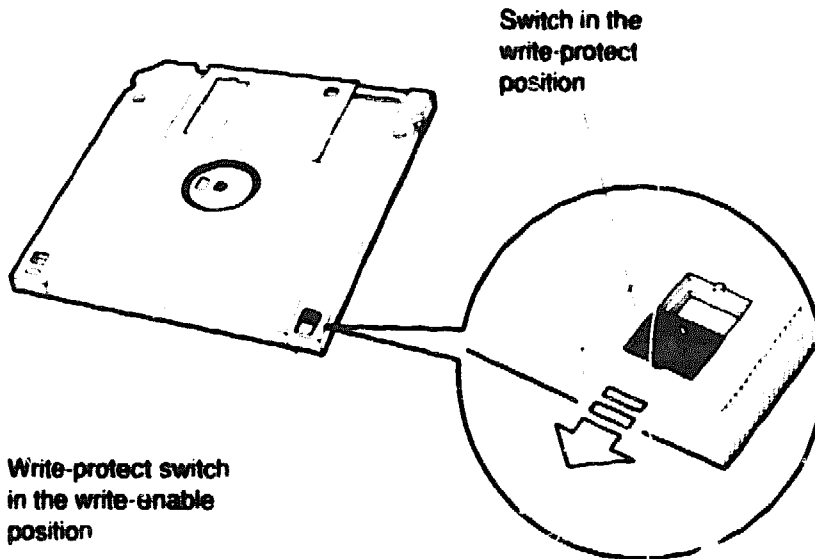

DERX032

Figure 6-3. Write-protecting a diskette

To Write-Enable a Diskette

1. Find the black write-protect switch in the lower-right corner of the back of the diskette.
2. Move the switch up until the hole in the diskette is closed and the switch clicks and locks into place.

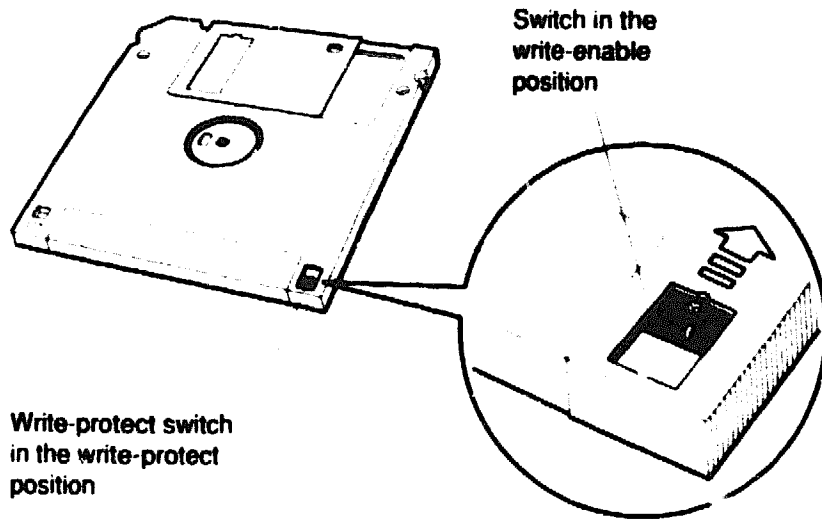

DERX040

Figure 6-4. Write-enabling a diskette

Inserting a Diskette into a Drive

To insert a diskette into a drive,

1. Position the diskette so the metal portion on the front of the diskette points to the center of the slot in the drive.

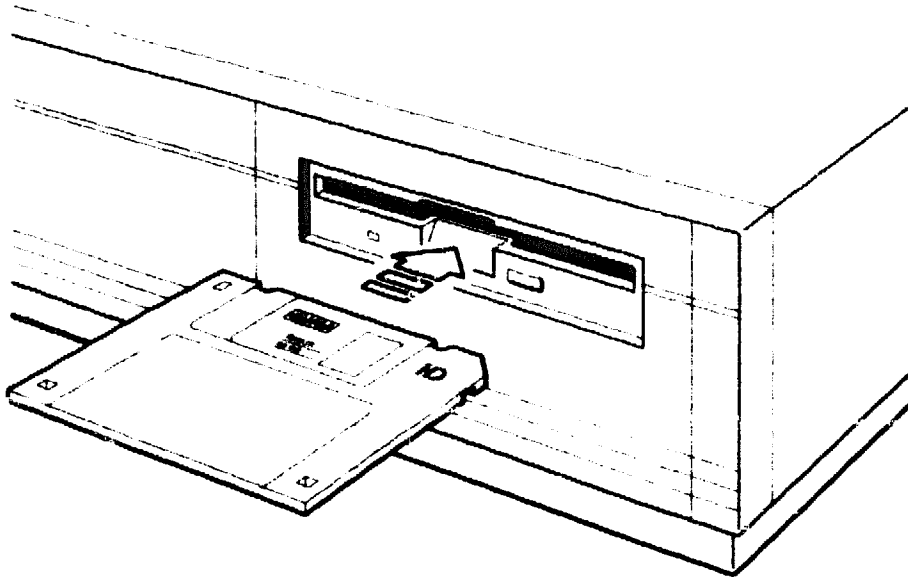

DERX036

Figure 6-5. A diskette positioned for insertion

2. Gently push the diskette into the slot until it clicks and drops down into place.

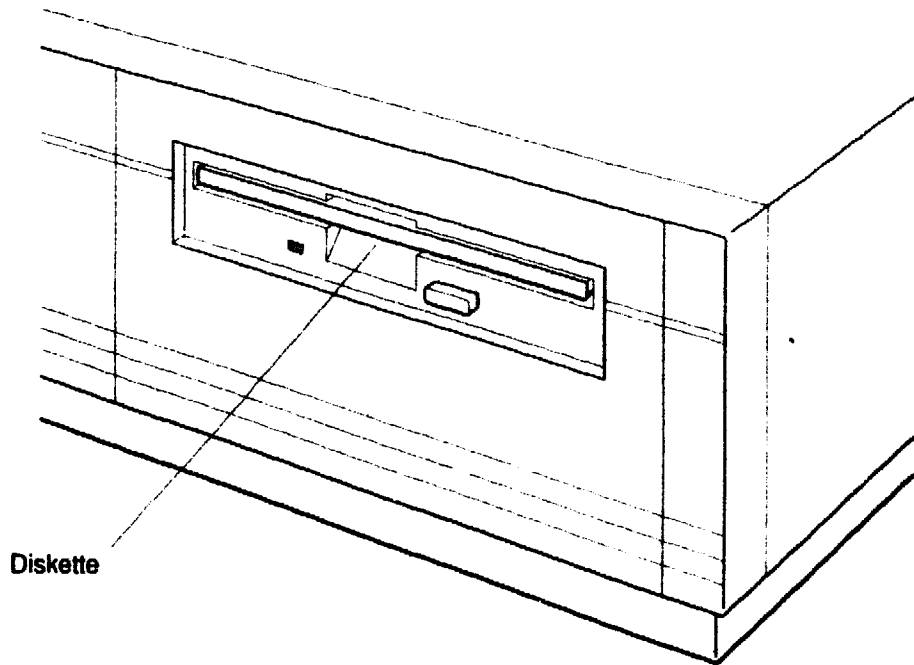

DERX037

Figure 6-6. A diskette positioned correctly in the drive

Removing a Diskette from a Drive

Caution: Removing a diskette from a drive while the indicator light glows yellow can damage the diskette and the drive.

If you are using your operating system or other software, see your software documentation for instructions for unmounting the diskette drive before removing the diskette from the drive.

To Remove a Diskette from a Drive

Press the eject button on the lower-right corner of the drive.

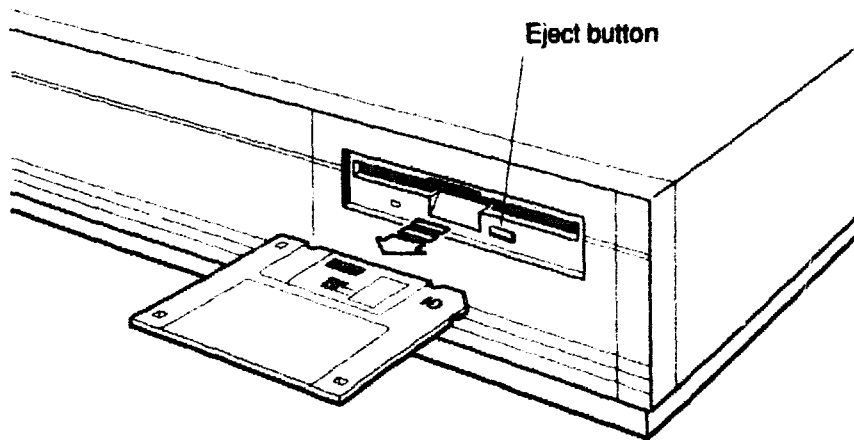

DERX038

Figure 6-7. Ejecting a diskette from the drive

Formatting a Diskette

A blank diskette must be formatted (prepared to receive data) before you can use it in your drive.

You can use either your console program or your worksystem software to format diskettes.

To Use the Console Program

Caution: *Formatting a diskette erases any data stored on that diskette.*

1. Find out the unit number for your diskette drive.

Type **test -c** at the console prompt (>>).

A display similar to the following appears on your screen:

```
MEM: 16Mbytes
VIDEO: MONO
ETHERNET STA ADDR: 08-00-2b-0d-f7-6a
SCSI DEVS:
U[7]
U[6] KN01--SII
U[5]
U[4]      Dev typ  0 RZ
          RMB          0x80 rmv mda
          Vrs          1
          Format        1 CCS
          Add len      31
          Vndr         DEC
          PID          RX23      (C) DEC
          Frevlvl      0051
U[3]
U[2]
U[1]
U[0]      Dev typ  0 RZ
          RMB          0x0
          Vrs          1
          Format        1 CCS
          Add len      31
          Vndr         DEC
          PID          RZ23      (C) DEC
          Frevlvl      0615
>>
```

In the display on the previous page, the unit numbers appear in brackets on the left side of the screen.

Any unit that contains a disk or diskette drive displays a unit-number line similar to the following:

```
U[4]      Dev typ   0 RZ
```

In the preceding example, the unit number is 4.

To determine whether the device is a hard disk drive or a diskette drive, look at the right-hand column under the unit-number line.

If you have a diskette drive, the second-to-last line in that column reads

```
RX23
```

2. Because the unit number in our example is 4, type **scsi cf 4** at the console prompt (>>) and press Return.

Note that the number you type here is always the unit number to which the diskette drive is assigned.

3. The following display appears at the bottom of your screen:

```
-04b-09 rz/tz wrt?  
Y/N?
```

At this point you can choose to continue formatting the diskette or to terminate the formatting procedure.

To Continue Formatting the Diskette

Type **Y** at the blinking prompt (`_`) and press **Return**. (Be sure to type an uppercase **Y**. The console program does not recognize uppercase and lowercase letters as being the same thing.)

When you do this, the following things happen:

1. The indicator light in the lower-left side of the drive glows yellow.

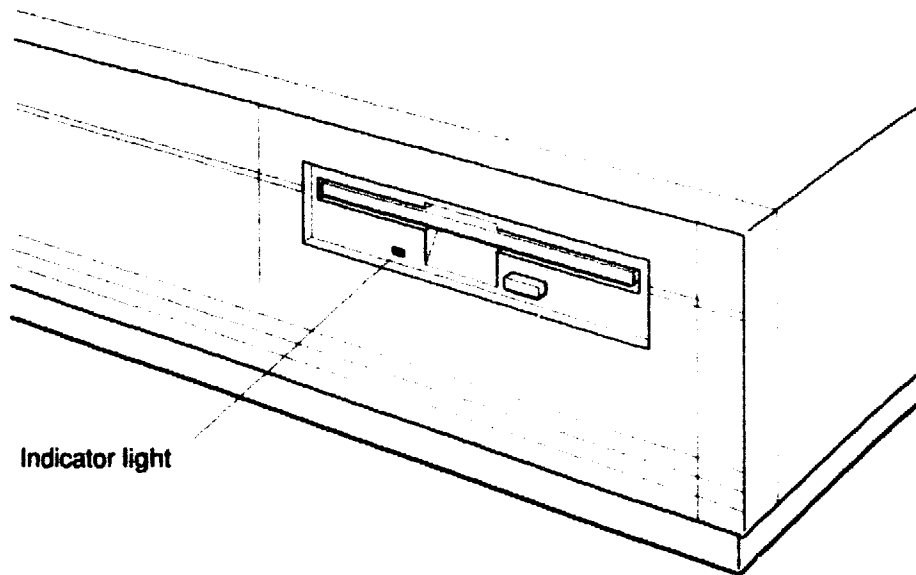

DERX039

Figure 6-8. The indicator light on the diskette drive

2. The following lines appear at the bottom of the display on your screen:

```
-04b-0d Fmt rz[5]  
-04b-11 wait!
```

3. The system then formats the disk and tests it to verify that it is formatted correctly.

This process takes about a minute and a half.

4. When tests are completed, two lines similar to the following appear at the bottom of the display:

```
Ps#      Blk      Ercnt
100      383      0
```

When the yellow light on the front of the drive goes out, the diskette is formatted and ready to use.

If a number other than 100 appears under `Ps#` or a number other than 0 appears under `Ercnt`, use another diskette.

If you are not using a high-density diskette or if your diskette is write-protected

When you type `Y` at the blinking prompt (`_`) and press `Return`, the following display appears at the bottom of the display on your screen:

```
-04b-0d Fmt rz[5]
-04b-11 wait!
?0d3-16 wrpt u# 00000005
```

- If you have a high-density diskette that is write-protected, write-enable it as described in this chapter.
- If you have a high-density diskette that is already write-enabled, replace it with a new diskette.
- If your diskette is not high density, replace it with a high-density diskette.

To Terminate the Formatting Procedure

Type **N** at the blinking prompt (**_**) on your screen and press Return.

The following display appears at the bottom of your display:

```
-04b-0a cmd abrt  
>>
```

When the console prompt (>>) appears, you can remove the diskette from the drive.

To Use Worksystem Software

Follow the instructions provided in your worksystem software documentation.

Troubleshooting

This chapter tells you

- **How to use the DECstation 2100/3100 self-test**
- **What you can do to correct hardware problems**
- **When you need to ask for help**
- **What kind of information your Digital service representative needs from you**

Using the Self-Test

The self-test consists of a number of subtests that check the parts of your workstation and tell you whether they are working correctly.

You can run the self-test in one of the following ways:

- By turning on your system unit
- By pressing the reset button on the back of the system unit
- By typing **test -a** at the console prompt (**>>**) and pressing Return

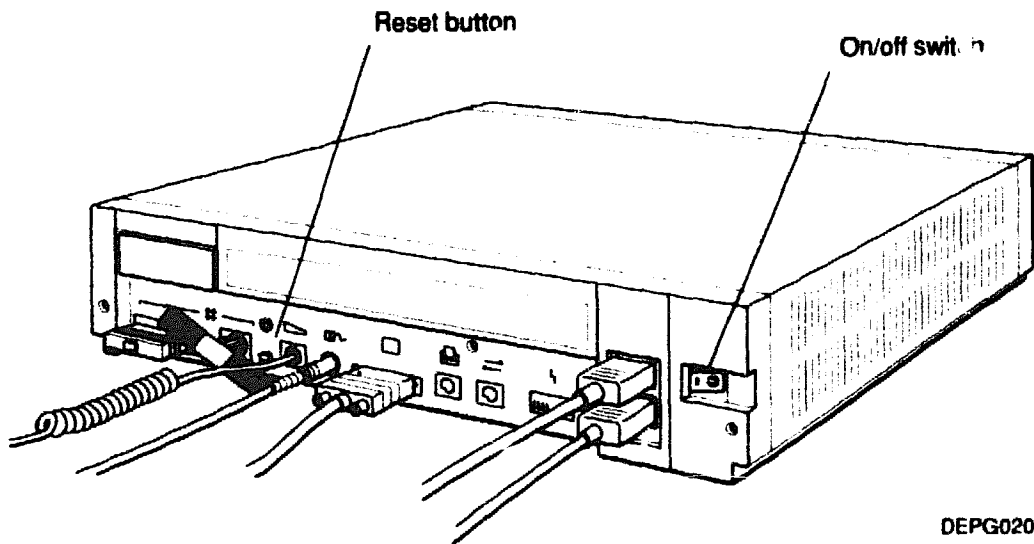

DEPG020

Figure 7-1. The on/off switch and reset button on the system unit

When you turn on the system unit or press the reset button, the self-test starts automatically.

If this power-up self-test is successful, a display similar to the following appears on your screen:

```
KN01 V6.71
7..6..5..4..3..2..1..0
16Mb.....0
KN01 V6.71
08-00-2b-0d-f7-6a
0x01000000
>>
```

When you type `test -a` to run the self-test, the power to the workstation is not turned off.

If this self-test is successful, a display similar to the following appears on your screen:

```
KN01 V6.71
7..6..5..4..3..2..1..0
16Mb.....0
>>
```

If a Subtest Fails

If your workstation fails one of the subtests, self-testing stops and a display similar to the following appears on the screen:

```
KN01 V6.71
7..6..5..4..3..2..
FAILURE
16Mb.....0
>>
```

The number of the subtest that failed is the last number that appears on your screen before the failure message. In the preceding example, subtest 2 failed.

If Subtest 7, 6, 5, or 4 Fails

Record the number of the subtest that failed and report it to your system manager or your Digital service representative.

If Subtest 3 Fails

Check your mouse and keyboard. Turn off your system unit before performing each of the following steps. Turn it back on to rerun the self-test.

Caution: *Checking a connection or connecting a new device with the system unit turned on can damage the system unit and the device.*

- Make sure the mouse and keyboard cable connectors are securely seated in their connectors on the back of the system unit.
- Try another mouse.
- Try another keyboard.

If the subtest still fails, report its number to your system manager or your Digital service representative.

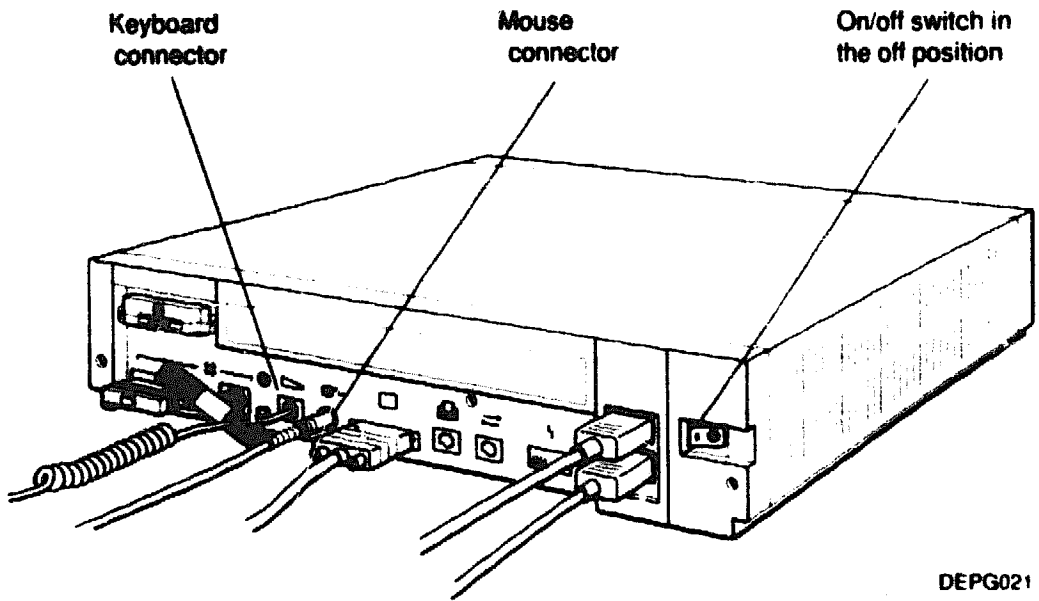

Figure 7-2. Checking the mouse and keyboard connections

If Subtest 2 Fails

Check your Ethernet connections.

Caution: *Checking a connection or connecting a cable to the system unit while the unit is turned on can damage the system unit.*

For a workstation not on a network

1. Make sure a ThickWire loopback connector is securely attached to the ThickWire connector on the back of the system unit (see Figure 7-3).

The light on the back of the loopback connector should glow green.

2. Turn off your system unit and make sure a ThinWire T-connector with a terminator on each end is securely attached to the ThinWire connector on the back of the system unit.
3. Turn on the system unit to rerun the self-test.
4. If your workstation continues to fail subtest 2, report the number of the subtest to your system manager or your Digital service representative.

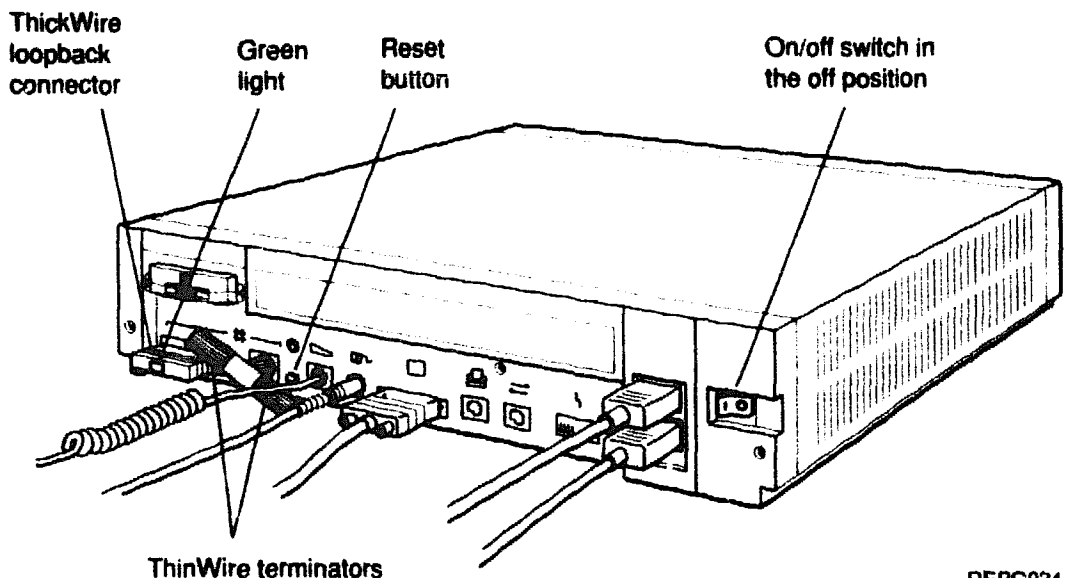

DEPG024

Figure 7-3. Checking Ethernet connections

For a workstation on ThickWire Ethernet

1. Turn off your system unit and make sure the ThickWire cable connector is securely attached to the ThickWire connector on the back of the system unit and that the slide latch is engaged.
2. Turn on the system unit to rerun the self-test.
3. Check the Ethernet indicator light that lies between the ThickWire connector and the Ethernet button.
 - a. If the light is not glowing green, use the point of a ballpoint pen or some similar tool (but not a pencil) to press the Ethernet button.

Caution: *The graphite in pencil lead can damage the system unit.*

- b. Press the reset button to rerun the self-test.

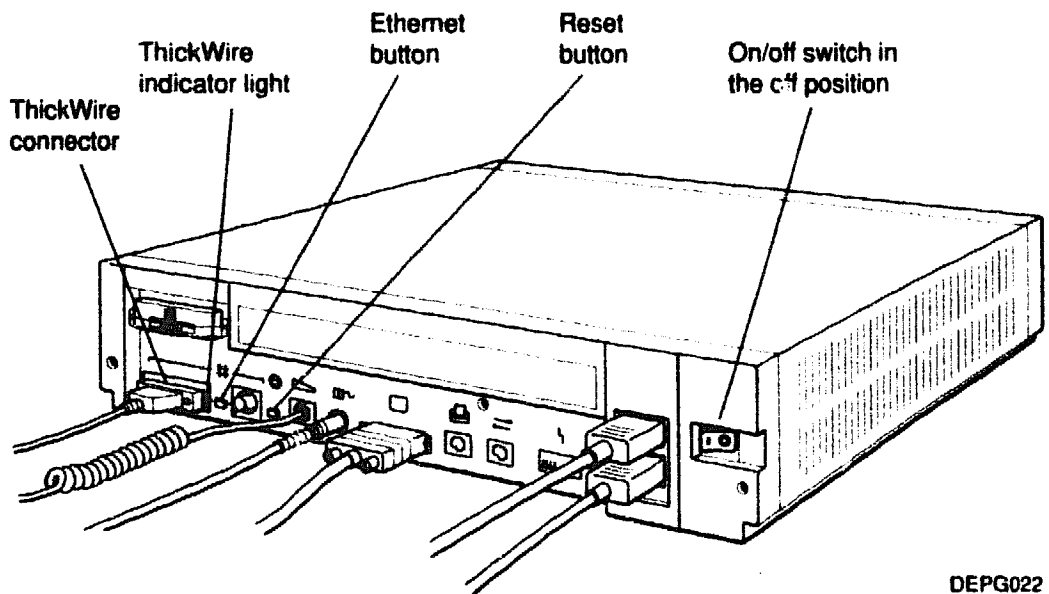

DEPG022

Figure 7-4. Checking ThickWire connections

- b.
 4. If the light still fails to glow green, or if your workstation continues to fail subtest 2, report the number of the subtest to your system manager or your Digital service representative.

For a workstation on ThinWire Ethernet

1. Turn off your system unit and make sure the ThinWire T-connector is securely connected to the ThinWire Ethernet connector on the back of the system unit (see Figure 7-5).
 - If your workstation is at the end of a ThinWire segment, make sure the ThinWire cable connector is firmly attached to one end of the T-connector and a ThinWire terminator is firmly attached to the other end.
 - If your workstation is within a ThinWire segment, make sure the ThinWire cable connectors are firmly attached to both ends of the T-connector.
2. Turn on the system unit to rerun the self-test.
3. Check the Ethernet indicator light that lies between the ThinWire connector and the Ethernet button.
 - a. If the light is not glowing green, use the point of a ballpoint pen or some similar tool (but not a pencil) to press the Ethernet button.

Caution: *The graphite in pencil lead can damage the system unit.*

- b. Press the reset button to rerun the self-test.

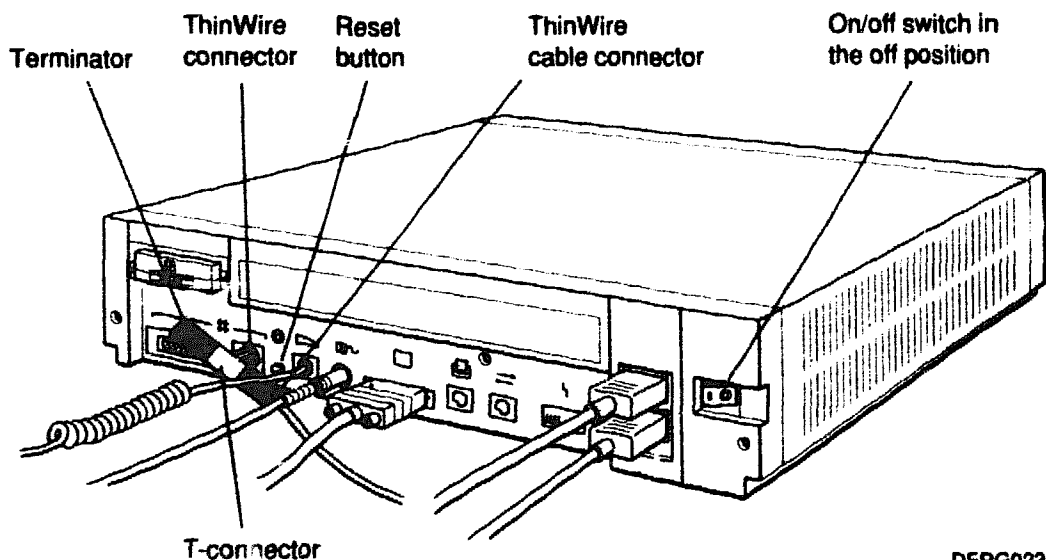

DEPG023

Figure 7-5. Checking ThinWire connections

4. If the light still fails to glow green, or if your workstation continues to fail subtest 2, report the number of the subtest to your system manager or your Digital service representative.

If Subtest 1 Fails

Check your small computer system interface (SCSI) connections.

Caution: *Checking a connection or connecting a cable to the system unit while the unit is turned on can damage the system unit.*

For a workstation with no external storage devices

1. Turn off your system unit and make sure the SCSI terminator is securely connected to the SCSI connector on the back of the system unit.
2. Check the connectors on the terminator and system unit for damaged pins.
3. Turn on the system unit to rerun the self-test.

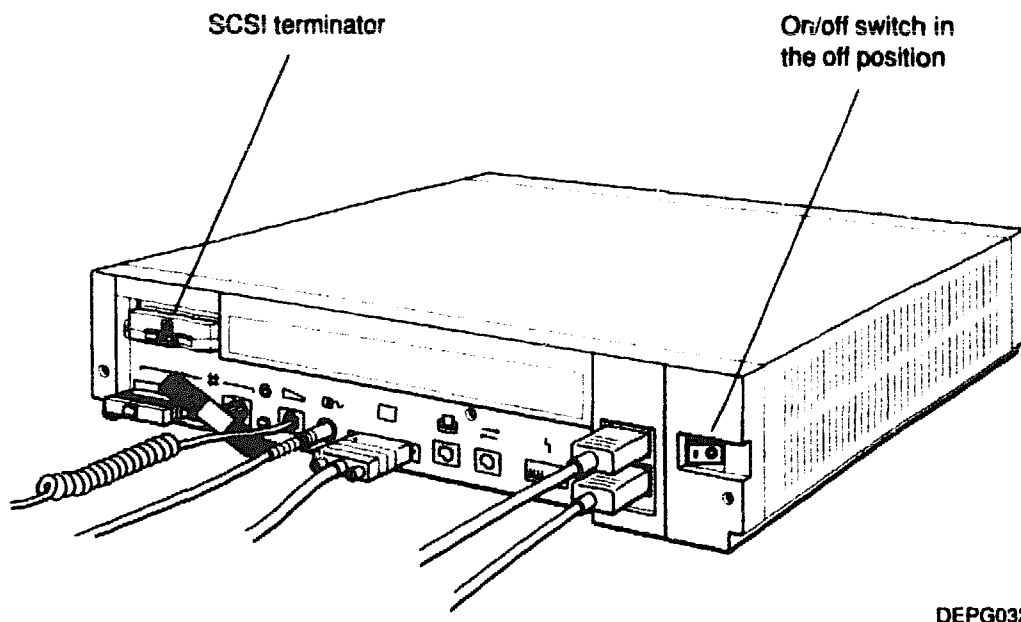
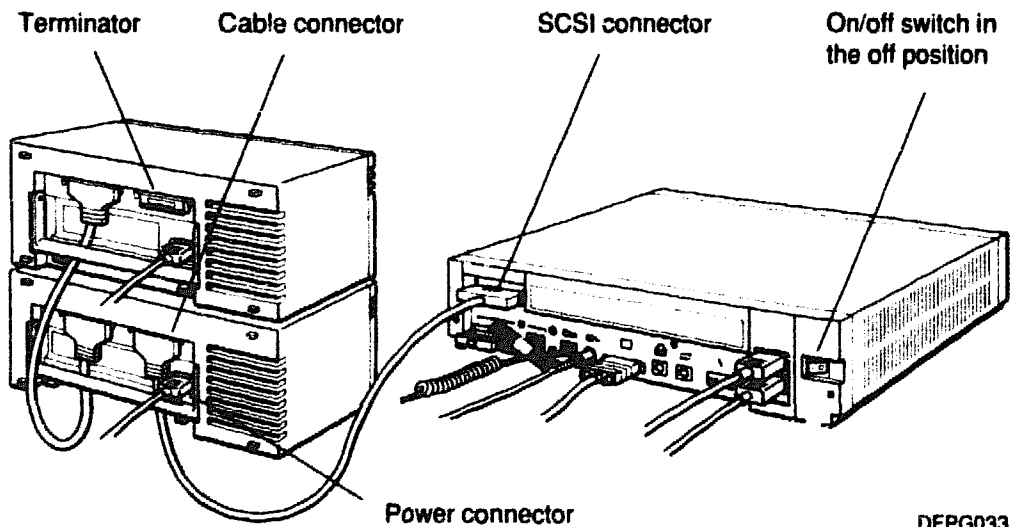

Figure 7-6. Checking the SCSI terminator

For a workstation with external storage devices

1. Turn off your system unit and any external storage devices. If you have more than one such device, turn off your power strip.
2. Make sure that
 - All storage device cables are securely connected
 - The final device has a terminator securely seated in the unused connector
 - All connectors are free of damaged pins
 - The cable that runs between expansion boxes is the 18-inch cable supplied by Digital
3. Turn on any external storage devices and your system unit to run the self-test. If you have more than one external storage device connected to your workstation, turn on your power strip.
4. If subtest 1 continues to fail, report the number of the subtest to your system manager or your Digital service representative.



DEPG033

Figure 7-7. Checking SCSI connections

Solving Hardware Problems

Table 7-1 offers solutions to some common hardware problems. If you follow the suggestions given here and your problem remains unresolved, contact your system manager or your Digital service representative.

For information for a BA42 storage expansion box, refer to the *BA42 Storage Expansion Box Installation Guide*.

Table 7-1. Solutions to Common Hardware Problems

Problem	Solution
The monitor screen is blank.	<p>Follow these steps:</p> <ol style="list-style-type: none">1. Press any key on your keyboard. If your screen saver was active, the display will reappear.2. Adjust your brightness and contrast controls to increase the brightness and contrast.3. Be sure your system unit and monitor are turned on.4. Turn off your system unit.5. Be sure the monitor-system unit power cable and the system unit power cord are connected correctly.6. Be sure the video cable is securely connected to the monitor and the system unit.7. Turn on your system unit.
The screen display is distorted or unstable.	<p>Follow these steps:</p> <ol style="list-style-type: none">1. Turn off your system unit.2. Make sure the video cable connectors are correctly attached to the monitor and system unit.3. Turn on the system unit.

(continued on next page)

Table 7-1 (Cont.). Solutions to Common Hardware Problems

Problem	Solution
Color is distorted or unclear.	<p>Follow these steps:</p> <ol style="list-style-type: none">1. Move any electric pencil sharpener or other electromechanical devices away from the monitor.2. Move such items as magnetic paper clip holders away from the monitor.3. Press the degauss button on the monitor for 5 seconds.4. If step 3 doesn't help, wait 10 minutes and press the degauss button for 5 seconds again.
On a color monitor, red or blue color is missing.	<p>Follow these steps:</p> <ol style="list-style-type: none">1. Turn off the system unit.2. Be sure the video cable connectors are correctly attached to the monitor and system unit.3. Turn on the system unit.
Everything happening on your screen freezes.	<p><i>If you are on a network, follow these steps:</i></p> <ol style="list-style-type: none">1. Wait a few minutes.2. Press the reset button. <p><i>If you are not on a network, press the reset button.</i></p>

(continued on next page)

Table 7-1 (Cont.). Solutions to Common Hardware Problems

Problem	Solution
When you type, nothing happens on the screen.	<p>Follow these steps:</p> <ol style="list-style-type: none">1. Press and release the Hold Screen key [F1] on your keyboard.2. Turn off your system unit.3. Make sure the keyboard cable is firmly attached to the system unit and turn on the system unit again.4. Turn off the system unit and try another keyboard.5. Turn on the system unit again.
You cannot log into the network.	<p><i>If you are using ThickWire Ethernet, follow these steps:</i></p> <ol style="list-style-type: none">1. Be sure the ThickWire Ethernet indicator light to the right of the ThickWire connector glows green. <p>If it does not, use the point of a ballpoint pen or some similar tool (but not a pencil), to press and release the Ethernet button.</p> <p><i>Caution: The graphite in pencil lead can damage the system unit.</i></p> <ol style="list-style-type: none">2. Turn off your system unit.3. Be sure your ThickWire connector is firmly attached to the ThickWire connector on the system unit.4. Turn on your system unit.

(continued on next page)

Table 7-1 (Cont.). Solutions to Common Hardware Problems

Problem	Solution
	<p><i>If you are using ThinWire Ethernet, follow these steps:</i></p> <ol style="list-style-type: none">1. Be sure the ThinWire Ethernet indicator light to the left of the ThinWire connector glows green. If it does not, use the point of a ballpoint pen or some similar tool (but not a pencil), to press and release the Ethernet button. Caution: <i>The graphite in pencil lead can damage the system unit.</i>2. Turn off your system unit.3. Be sure your ThinWire cable connector(s) and/or terminators are firmly attached to the ThinWire T-connector.4. Be sure the ThinWire T-connector is correctly attached to the ThinWire connector on the system unit.5. Turn on your system unit.
No cursor appears on the screen.	<p>Follow these steps:</p> <ol style="list-style-type: none">1. Move the mouse around on your desktop to be sure you haven't accidentally moved the cursor off your screen.2. Turn off your system unit.3. Make sure the mouse cable is correctly connected to the system unit.4. Turn on your system unit.5. Turn off your system unit and try another mouse.

(continued on next page)

Table 7-1 (Cont.). Solutions to Common Hardware Problems

Problem	Solution
The cursor on the screen fails to follow the movement of the mouse on the desktop.	Follow these steps: <ol style="list-style-type: none">1. Turn off your system unit.2. Be sure the mouse cable is correctly connected to the system unit.3. Turn on the system unit.4. Turn off the system unit.5. Disconnect the mouse and clean it as described in Chapter 1 of this guide.6. Reconnect the mouse and turn on the system unit.7. Turn off the system unit and try another mouse.
An error message appears when you try to use an internal diskette drive.	<ol style="list-style-type: none">1. Be sure you are using a high-density diskette.2. If you are trying to write to the diskette, be sure the diskette is not write-protected.3. Try another high-density diskette.4. Consult the documentation that came with your software for further troubleshooting instructions.
An error message appears when you try to use an external hard disk or tape drive.	<p><i>If you have only one external storage device, follow these steps:</i></p> <ol style="list-style-type: none">1. Be sure the device is turned on.2. Turn off the device and the system unit.3. Be sure the system unit expansion cable is correctly connected to the device and the system unit.4. Be sure a terminator is correctly attached to the second connector on the device.5. Turn on the device and the system unit.

(continued on next page)

Table 7-1 (Cont.). Solutions to Common Hardware Problems

Problem	Solution
	<p><i>If you have more than one external storage device, follow these steps:</i></p> <ol style="list-style-type: none">1. Be sure all devices are turned on.2. Turn off the power strip.3. Be sure the system unit expansion cable is correctly connected to the first device and the system unit.4. Be sure the connector cables between devices are the 18-inch cables supplied by Digital and that they are connected correctly.5. Be sure a terminator is firmly attached to the second connector on the final device.6. Turn on the power strip.
<p>A red light blinks rapidly on the front of your tape drive.</p>	<p>Follow these steps:</p> <ol style="list-style-type: none">1. Push the load/unload button four times.2. Turn the tape drive off and then back on again. Do this only one time.
<p>The top light blinks, or both lights are yellow at the same time, on the front of your cassette tape drive.</p>	<p>Refer to the <i>TLZ04 Cassette Tape Drive Owner's Manual</i>.</p>

(continued on next page)

Table 7-1 (Cont.). Solutions to Common Hardware Problems

Problem	Solution
An error message appears when you try to use your printer.	<p>Follow these steps:</p> <ol style="list-style-type: none">1. Be sure your printer is turned on.2. Turn off your printer and system unit.3. Be sure your printer power cord is connected to an active power source.4. Be sure the printer cable connector is correctly attached to the printer connector on the system unit.5. Turn on your printer and system unit.6. See the documentation that came with your printer for instructions on checking your printer's baud rate.
An error message appears when you try to use your communications device.	<p>Follow these steps:</p> <ol style="list-style-type: none">1. Be sure your device is turned on.2. Turn off your device and your system unit.3. Be sure your device's power cord is connected to an active power source.4. Be sure the connector on the communications device cable is correctly attached to the communications connector on the system unit.5. Turn on your device and system unit.6. See the documentation that came with your communications device for instructions on checking your device's baud rate.

Contacting Your Digital Service Representative

If you have followed the suggestions offered in this chapter and your problem remains unresolved, your Digital service representative can help you. You can get your service representative's name and telephone number from your Digital sales representative.

Before you place your call,

- Write down the nature of the problem, including any error messages you have received and the number of any self-test that failed.
- List the steps you have taken to correct the problem and the results you got.
- Write down the serial and model numbers of your system and any peripheral device involved.
- Be prepared to type commands on the keyboard and read information from the screen as you talk to your service representative.

Moving the DECstation 2100/3100 Workstation

This chapter tells you how to take your workstation apart and pack it in preparation for moving.

When you move your workstation, repack each piece of equipment in the carton it came in.

Dismantling the Workstation

1. Follow the procedures for turning off your workstation given in Chapter 3 of this guide.
2. Unplug all power cords from the power source.
3. Disconnect any optional peripheral devices from the system unit, and if you have more than one expansion box, disconnect them from each other.
4. If you have a small computer system interface (SCSI) terminator in the SCSI connector on the back of the system unit, remove the terminator from that connector.
5. Replace the plastic cover that protected the SCSI connector when you first received the system unit.
 - a. Line up the top and sides of the cover with the top and sides of the opening around the SCSI connector.
 - b. Press up on the latch on the bottom of the cover until you can push it into the slot under the connector and the cover snaps into place.
6. Disconnect the monitor, mouse, and keyboard from the system unit.
7. If you are on a network, disconnect your Ethernet cable from the connector on the system unit.

Caution: *Disconnecting the Ethernet cable at the network instead of at the system unit interrupts network performance.*

Packing Your Equipment

Pack each piece of equipment in the carton it came in.

Be sure to use the padding that came in the cartons to hold each item securely in place.

Be sure to include the following in each carton:

- **Any cables, power cords, and terminators that came with that device**
- **The documentation for that device**

Reinstalling Your DECstation 2100/3100

To reinstall your workstation, follow the instructions in the *DECstation 2100/3100 Hardware Installation Guide*, which came in your DECstation 2100/3100 documentation kit.

Equipment Specifications

This appendix lists the physical specifications, operating conditions, and nonoperating conditions for components listed here. For information on drives in the BA42 storage expansion box, see Appendix A in the *BA42 Storage Expansion Box Installation Guide*.

- System unit
- VR150 monitor
- VR160 monitor
- VR262 monitor
- VR297 monitor
- VR299 monitor
- LK201 keyboard
- VSXXX-AA mouse
- RZ55 hard disk drive
- TK50Z tape drive
- TLZ04 cassette tape drive
- RRD40 optical compact disc drive
- RZ23 hard disk drive
- RZ23L hard disk drive
- RZ24 hard disk drive
- RX23 diskette drive

Table A-1. System Unit Description

	Weight	Height	Width	Depth
System unit	17.8 kg (39 lb)	149.9 mm (5.90 in.)	463.8 mm (18.26 in.)	400.0 mm (15.75 in.)

Table A-2. System Specifications

Input voltage	Auto adjust 100-120 Vac to 220-240 Vac
Input current	2.8 amps at 100 to 120 Vac 1.5 amps at 220 to 240 Vac
Power	
- Frequency	47 to 63 Hz
- Heat dissipation	190 watts, maximum

Table A-3. System Unit Operating Conditions

Temperature range¹	10° C to 40° C (50° F to 104° F)
Temperature change rate	11° C (20° F) per hour, maximum
Relative humidity	10% to 90%, noncondensing
Maximum wet-bulb temperature	28° C (82° F)
Minimum dew-point temperature	2° C (36° F)
Altitude	2,400 m (8,000 ft) at 36° C (97° F)

¹Reduce maximum temperature by 1.8° C (3.24° F) for each 1,000-meter (3333.33 ft) increase in altitude.

Table A-4. System Unit Nonoperating Conditions

Temperature range	- 40° C to 66° C (- 40° F to 151° F)
Relative humidity	10% to 95%
Maximum wet-bulb temperature	46° C (115° F), packaged
Minimum dew-point temperature	2° C (36° F)
Altitude	4,900 m (16,000 ft)

Table A-5. VR150 Monitor Description

	Weight	Height	Width	Depth
Monitor	16.34 kg (36 lb)	394 mm (15.5 in.)	369 mm (14.5 in.)	403 mm (15.9 in.)

Table A-6. VR150 Monitor Specifications

External controls, switches, and indicators	Brightness Contrast Power switch Power indicator
Tilt range	- 5° to + 13°
Swivel range	± 60°
Display	
- Cathode-ray tube (CRT)	383 mm (15 in.) diagonal flat square Paper white phosphor High-efficiency antiglare treatment; reflects less than 1% of incident light within the visible spectrum
- Video input	75 ohms terminated BNC composite video 1.0 Vpp/75 ohm
- Display characteristics	1,024 pixels horizontal x 864 lines vertical, giving approximate picture size of 240 mm x 203 mm Maximum contrast no less than 30 footlamberts (fl)
Horizontal rate timing	
- Frequency timing	54.054 kHz
- Front porch	160 ns
- Sync pulse	1,850 ns
- Back porch	1,680 ns
- Blanking interval	3.70 μs maximum
- Active video time	14.8 μs
- Horizontal period	18.5 μs
- Pixels displayed	1,024

(continued on next page)

Table A-6 (Cont.). VR150 Monitor Specifications

Vertical rate timing

- Frequency	60 Hz
- Front porch	0 horizontal lines
- Sync pulse	3 horizontal lines
- Blanking interval	37 horizontal lines
- Active video time	16.0 ms
- Vertical period	16.67 ms
- Lines displayed	864

Video rate (bandwidth)

- Pixel frequency	70 MHz
- Pixel period	14.45 ns nominal

Power

- AC input voltage	88-132/185-254 Vac
- Frequency	50/60 Hz
- Power consumption	70 watts nominal

Table A-7. VR150 Monitor Operating Conditions

Temperature range	10° C to 40° C (50° to 104° F)
Relative humidity	10% to 95%, noncondensing
Maximum wet-bulb temperature	32° C (89° F)
Minimum dew-point temperature	2° C (36° F)
Altitude	2,400 m (8,000 ft) at 36° C (96° F)

Table A-8. VR150 Monitor Nonoperating Conditions

Temperature range	- 40° C to 66° C (- 40° F to 150° F)
Relative humidity	10% to 95%, noncondensing
Maximum wet-bulb temperature	46° C (115° F), packaged
Minimum dew-point temperature	2° C (36° F)
Altitude	4,900 m (16,000 ft) at 36° C (96° F)

Table A-9. VR160 Monitor Description

	Weight	Height	Width	Depth
Monitor	23 kg (51 lb)	394 mm (15.5 in.)	369 mm (14.5 in.)	457 mm (18 in.)

Table A-10. VR160 Monitor Specifications

External controls, switches, and indicators	Brightness Contrast Degauss Power switch Power indicator
Tilt range	- 7° to + 16°
Swivel range	± 60°
Display	
- Cathode-ray tube (CRT)	383 mm (15 in.) diagonal Color phosphor, medium persistence P22 RGB phosphor Color 0.28 pitch shadow mask High-efficiency antiglare treatment; reflects less than 1% of incident light within the visible spectrum
- Video input	Composite video Red: 0.7 Vpp/75 ohm Green (with sync): 1 Vpp/75 ohm Blue: 0.7 Vpp/75 ohm
- Display characteristics	1,024 pixels horizontal x 864 lines vertical, giving approximate picture size of 240 mm x 203 mm Maximum contrast no less than 30 footlamberts (f)
Power	
- Voltage range (switch selectable)	DA model, 88 - 132 Vac

(continued on next page)

Table A-10 (Cont.). VR160 Monitor Specifications

	D3, D4 models, 185 - 264 Vac
- Frequency	50/60 Hz
- Power consumption	125 watts/200 VA nominal 150 watts/250 VA maximum

Table A-11. VR160 Monitor Operating Conditions

Temperature range	10° C to 40° C (50° to 104° F)
Relative humidity	10% to 95%, noncondensing
Maximum wet-bulb temperature	32° C (89° F)
Minimum dew-point temperature	2° C (36° F)
Altitude	2,400 m (8,000 ft) at 36° C (96° F)

Table A-12. VR160 Monitor Nonoperating Conditions

Temperature range	- 40° C to 66° C (- 40° F to 151° F)
Relative humidity	10% to 95%, noncondensing
Maximum wet-bulb temperature	46° C (115° F), packaged
Minimum dew-point temperature	2° C (36° F)
Altitude	4,900 m (16,000 ft) at 36° C (96° F)

Table A-13. VR262 Monitor Description

	Weight	Height	Width	Depth
Monitor	19.2 kg (42 lb)	394 mm¹ (15.5 in.)	455 mm (17.9 in.)	395 mm (15.4 in.)

¹Including feet**Table A-14. VR262 Monitor Specifications**

External controls, switches, and indicators	Brightness Contrast Power switch Power indicator
Display	
- Cathode-ray Tube (CRT)	High resolution Paper white phosphor Spot size approximately 0.3 mm
- Video input	High-efficiency antiglare treatment
- Display characteristics	Maximum 1,024 pixels horizontal x 864 pixels vertical, giving an approximate picture size of 334 mm x 282 mm
Horizontal rate timing nominal	
- Frequency	54.054 kHz
- Front porch	160 ns
- Sync pulse	1,850 ns
- Back porch	1,690 ns
- Blanking interval	3.70 μs maximum
- Active video time	14.8 μs
- Horizontal period	18.5 μs
- Pixels displayed	1,024

(continued on next page)

Table A-14 (Cont.). VR262 Monitor Specifications

Vertical rate timing (nominal)

- Frequency	60 Hz
- Front porch	0 horizontal lines
- Sync pulse	3 horizontal lines
- Blanking interval	37 horizontal lines max
- Active video time	16.0 ms
- Vertical period	16.67 ms
- Lines displayed	864

Power

- Power supply type	Transistor, switch type AC to DC converter
- AC input	Switch-selectable
- Power consumption	Approximately 65 watts

Fuse

100 to 120 Vac: 1 A 6.35 mm x 31.8 mm (.25 x 1.25 in.) slow blow (Digital PN 90-07212-00)
220 to 240 Vac: 1A 5 mm x 20 mm time lag (Digital PN 12-19283-00)

Table A-15. VR262 Monitor Operating Conditions

Temperature range	10° C to 40° C (50° F to 104° F)
Temperature change rate	11° (20° F) per hour maximum
Relative humidity	10% to 90%, noncondensing
Maximum wet-bulb temperature	28° C (82° F)
Minimum dew-point temperature	2° C (36° F)

Table A-16. VR262 Monitor Nonoperating Conditions

Temperature range	- 40° C to 66° C (- 40° F to 151° F)
Relative humidity	10% to 95%, noncondensing
Maximum wet-bulb temperature	46° C (115° F), packaged
Minimum dew-point temperature	2° C (36° F)

Table A-17. VR297 Monitor Description

	Weight	Height	Width	Depth
Monitor	29 kg (64 lb)	406 mm (16 in)	406 mm (16 in)	450 mm (17.75 in)

Table A-18. VR297 Monitor Specifications

External controls, switches, and indicators	V-STAT, H-STAT, V-CENT Contrast Power switch and indicator
Display	
- Cathode-ray tube (CRT)	0.26 mm phosphor pitch aperture grill 16 in measured diagonally 90° deflection
- Video input	Composite with sync on green Red/blue: 0.714 V_p p at 75 Ohms Green: 1.0 V_p p at 75 Ohms
- Display characteristics	1,024 pixels horizontal x 864 pixels vertical
Horizontal rate timing	
- Frequency	54.04 kHz
- Front porch	160 ns
- Sync pulse	1,850 μs
- Back porch	1,680 μs
- Blanking interval	3.70 μs
- Active video	14.8 μs
Vertical rate timing	
- Frequency	60 Hz
- Front porch	0 lines
- Sync pulse	3 lines
- Blanking interval	37 lines
- Active video	16.0 ms
- Vertical period	16.67 ms

(continued on next page)

Table A-18 (Cont.). VR297 Monitor Specifications

Power	
– Power supply type	Transistor, switch-type AC to DC converter
– AC input	Switch-selectable
– Power consumption	Approximately 65 watts
Fuse	100 to 120 V: 2.4 A/2.2A 6.35 mm x 31.8 mm (.25 x 1.25 in) slow blow 220 to 240 V:1.4 A/1.3A 5 mm x 20 mm time lag

Table A-19. VR297 Monitor Operating Conditions

Temperature range	10° C to 40° C (50° F to 104° F)
Relative humidity	10% to 90%, noncondensing
Maximum wet-bulb temperature	28° C (82° F)
Minimum dew-point temperature	2° C (36° F)

Table A-20. VR297 Monitor Nonoperating Conditions

Temperature range	– 40° C to 66° C (– 40° F to 151° F)
Relative humidity	10% to 95%, noncondensing
Maximum wet-bulb temperature	46° C (115° F), packaged
Minimum dew-point temperature	2° C (36° F)

Table A-21. VR299 Monitor Description

	Weight	Height	Width	Depth
Monitor	32 kg (70 lbs)	470 mm (18.5 in.)	506 mm (19.9 in.)	525 mm (20.7 in.)

Table A-22. VR299 Monitor Specifications

External controls, switches, and indicators	Brightness Contrast Degauss Power switch Power indicator Voltage selector switch
Tilt range	- 5° to + 150°
Swivel range	± 200°
Display	
- Cathode-ray tube (CRT)	508 mm (20 in.) diagonal Color phosphor, medium persistence P22 RGB phosphor Color 0.32 mm pitch shadow mask High-efficiency antiglare treatment; reflects less than 1% of incident visible light
- Video input	Composite video Red: 0.7 Vpp/75 ohm Green (with sync): 0.7 Vpp/75 ohm Blue: 0.7 Vpp/75 ohm
- Display characteristics	1,024 pixels horizontal x 864 pixels vertical, giving approximate picture size of 326 mm x 275 mm Contrast 35 footlamberts (f) maximum
Horizontal rate timing	
- Frequency timing	54.054 kHz
- Front porch	159 ns
- Sync pulse	1,850 ns
- Back porch	1,680 ns

(continued on next page)

Table A-22 (Cont.). VR299 Monitor Specifications

- Blanking interval 3.69 μ s maximum
- Active video time 14.8 μ s
- Horizontal period 18.5 μ s

Vertical rate timing

- Frequency 60 Hz
- Front porch 0 horizontal lines
- Sync pulse 3 horizontal lines
- Blanking interval 37 horizontal lines
- Active video time 16.0 ms
- Vertical period 16.67 ms

Power

- AC input voltage (switch selectable) 88-132/185-254 Vac
- Frequency 50/60 Hz
- Power consumption 150 watts maximum

Fuse

- 3.2 A for 120 V system
 - 1.6 A for 240 V system
-

Table A-23. VR299 Monitor Operating Conditions

Temperature range	10° C to 40° C (50° to 104° F)
Relative humidity	10% to 95%, noncondensing
Maximum wet-bulb temperature	32° C (89° F)
Minimum dew-point temperature	2° C (36° F)
Altitude	2,400 m (8,000 ft) at 36° C (96° F)

Table A-24. VR299 Monitor Nonoperating Conditions

Temperature range	- 40° C to 66° C (- 40° F to 150° F)
Relative humidity	10% to 95%, noncondensing
Maximum wet-bulb temperature	46° C (115° F), packaged
Minimum dew-point temperature	2° C (36° F)
Altitude	4,900 m (16,000 ft) at 36° C (96° F)

Table A-25. LK201 Keyboard Description

	Weight	Height	Width	Depth
Keyboard	2 kg (4.5 lb)	51 mm (2 in.)	533 mm (21 in.)	171 mm (6.75 in.)

Table A-26. LK201 Keyboard Specifications

Number of keys	105
Number of indicators	4 status LEDs
Language variations	15
Diagnostics	Self-testing and self-identifying with respect to revision level but not with respect to language variants
Cable	1.76 m (6 ft) uncoiled, detachable; 4-pin mmj connector at both ends
Baud rate	4800
Power consumption	4.2 watts maximum
Power input	11.8 V +/- 6% @ 350 ma
Electrical interface	EIA RS 423
Volume control	8 levels, plus off; maximum 65 dba 1 ft above keyboard
Keystroke timing	20 Msec minimum

Table A-27. LK201 Keyboard Operating Conditions

Temperature range	10° C to 40° C (50° F to 104° F)
Relative humidity	10% to 90%
Maximum wet-bulb temperature	28° C (82° F)
Minimum dew-point temperature	2° C (36° F)
Altitude	2,400 m (8,000 ft) at 36° C (96° F)

Table A-28. LK201 Keyboard Nonoperating Conditions

Temperature range	- 40° C to 66° C (- 40° F to 151° F)
Relative humidity	10% to 95%, noncondensing
Maximum wet-bulb temperature	46° C (115° F), packaged
Minimum dew-point temperature	2° C (36° F)
Altitude	4,900 m (16,000 ft) at 36° C (96° F)

Table A-29. VSXXX-AA Mouse Description

	Weight	Height	Diameter
Mouse	0.82 kg (0.37 lb)	40 mm (1.57 in.)	88 mm (3.47 in.)

Table A-30. VSXXX-AA Mouse Specifications

Baud rate	4800
Cable length	1.5 m (5 ft), shielded, 6 conductors and terminals in a 7-pin micro-DIN-type connector (male)
Resolution	79 counts/(200 counts/in.)
Tracking speed	73.5 cm (30 in./sec)
Electrical interfaces	EIA RS-232-C or TTL
Operating modes	Incremental or polling
Tracking rate	In incremental mode: 55 reports/sec In polling mode: up to 95 reports/sec
Accuracy	+/- 3% 0 to 24.5 cm/sec (0 to 10 in./sec) any direction +/- 15% 24.5 to 49 cm/sec (10 to 20 in./sec) any direction +/- 30% 49 to 73.5 cm/sec (20 to 30 in./sec) any direction
Data format	Delta binary
Buttons	3
Diagnostics	Self-testing and self-identifying with respect to revision level
Power requirements	+5 V +/- 5% at 130 mA - 12 V +/- 10% at 20 mA

Table A-31. VSXXX-AA Mouse Operating Conditions

Temperature range	10° C to 40° C (50° F to 104° F)
Relative humidity	10% to 90%, noncondensing
Maximum wet-bulb temperature	28° C (82° F)
Minimum dew-point temperature	2° C (36° F)
Altitude	2,400 m (8,000 ft) at 36° C (96° F)

Table A-32. VSXXX-AA Mouse Nonoperating Conditions

Temperature range	- 40° C to 66° C (- 40° F to 151° F)
Relative humidity	5% to 95%
Maximum wet-bulb temperature	46° C (115° F), packaged
Minimum dew-point temperature	2° (36° F)
Altitude	4,900 m (16,000 ft) at 36° C (96° F)

Table A-33. RZ55 SCSI Hard Disk Drive Description

	Weight	Height	Width	Depth
Expansion box	13.2 kg (29 lb)	140 mm (3.25 in.)	330 mm (12.75 in.)	290 mm (11.25 in.)
Internal drive	3.78 kg (8.4 lb)	825 mm (3.25 in.)	1460 mm (5.75 in.)	2082 mm (8.20 in.)

Table A-34. RZ55 SCSI Hard Disk Drive Specifications

Capacity	332.3 Mbytes
- Per surface	22.48 Mbytes
- Per track	18,432
- Per block	512 bytes
Blocks	36 per track 649,040 per drive
Spare blocks	8 per track 10,300 per drive
Transfer rate to/from media	1.25 Mbytes/sec
Bus asynchronous mode	1.5 Mbytes/sec
Bus synchronous mode	4 Mbytes/sec
Seek time	<= 4 Msec track-to-track <= 16 Msec average <= 35 Msec maximum
Average latency	8.3 Msec
Rotational speed	3,600 RPM
Start time	20 sec maximum
Stop time	20 sec maximum
Interleave	1:1
Bus latency	600 μsec maximum
Heat dissipation	32 watts maximum
Recording density (bpi at ID)	21,231
Track density (Epi)	1,075
Tracks/surface (unformatted)	1,224
R/W heads	15

Table A-35. RZ55 SCSI Hard Disk Drive Operating Conditions

Temperature range ¹	10° C to 55° C (50° F to 131° F)
Relative humidity	20% to 80%, noncondensing
Maximum wet-bulb temperature	25.6° C (78° F)
Minimum dew-point temperature	2° C (36° F)
Altitude	- 304 to 4,600 m (- 1,000 ft to 15,000 ft) at 36° C (96° F)

¹Reduce maximum temperature by 1.8° C (3.24° F) for each 1,000-meter increase in altitude.

Table A-36. RZ55 SCSI Hard Disk Drive Nonoperating Conditions

Temperature range	- 40° C to 66° C (- 40° F to 151° F)
Relative humidity	20% to 95%, packaged
Maximum wet-bulb temperature	46° C (115° F), packaged
Minimum dew-point temperature	2° C (36° F)
Altitude	- 304 to 12,300 m (- 1,000 ft to 40,000 ft) at 36° C (96° F)

Table A-37. TK50Z Tape Drive Description

	Weight	Height	Width	Depth
Expansion box	12.7 kg (28 lb)	139.7 mm (5.5 in.)	323,8 mm (12.75 in.)	285.7 mm (11.25 in.)

Table A-38. TK50Z Tape Drive Specifications

Mode of operation	Streaming
Media	12.77 mm (.5 in.), 600 ft. long magnetic tape
Bit density	6,667 bits/in.
Number of tracks	22
Transfer rate (at host)	360 Kbits/sec (45 Kbytes/sec)
Type speed	75 in./sec
Track format	Serpentine
Cartridge capacity	131 Mbytes, unformatted
Power requirements	+12 Vdc +/- 5% + 5 Vdc +/- 5%
Input current	2.4 amps at 100 to 120 Vac 1.3 amps at 220 to 240 Vac
Power	160 watts
Frequency	50 to 60 Hz
Heat dissipation	32 watts maximum

Table A-39. TK50Z Tape Drive Operating Conditions

Temperature range ¹	10° C to 40° C (50° F to 104° F)
Relative humidity	10% to 80%, noncondensing
Maximum wet-bulb temperature	28° C (82° F)
Minimum dew-point temperature	2° C (36° F)
Altitude	2,400 m (8,000 ft) at 36° C (96° F)

¹Reduce maximum temperature by 1.8° C (3.24° F) for each 1,000-meter increase in altitude.

Table A-40. TK50Z Tape Drive Nonoperating Conditions

Temperature range	- 30° C to 66° C (- 22° F to 151° F)
Relative humidity	10% to 95%, noncondensing
Maximum wet-bulb temperature	46° C (115° F), packaged
Minimum dew-point temperature	2° C (36° F)
Altitude	9,140 mm (30,000 ft) at 36° C (96° F)

Table A-41. TLZ04 Cassette Tape Drive Description

	Weight	Height	Width	Depth
Expansion box	12.7 kg (28 lb)	102 mm (4 in)	219.2 mm (8.63 in)	285.7 mm (11.25 in)

Table A-42. TLZ04 Cassette Tape Drive Specifications

Mode of operation	Streaming and start/stop
Drive interface	SCSI
Media	TLZ04-CA cassette tape
Bit density	114 Mbits per square inch
Transfer rate	156 Kbytes/sec
Track format	Digital Data Storage (DDS)
Cassette capacity	1.2 Gbytes
Power requirements	100 to 120V, 1.6 amps 200 to 240V, 1.0 amps
Power consumption	230 watts

Table A-43. TLZ04 Cassette Tape Drive Operating Conditions

Temperature range ¹	10° C to 40° C (50° F to 104° F)
Relative humidity	20% to 80%, noncondensing
Altitude	0 km to 4.6 km (0 to 15,000 ft)

¹Reduce maximum temperature by 1.8° C (3.24° F) for each 1,000-meter (3333.33 ft) increase in altitude.

Table A-44. TLZ04 Cassette Tape Drive Nonoperating Conditions

Temperature range	- 45° C to 45° C (49° F to 113° F)
Relative humidity	5% to 95%, noncondensing
Altitude	0 km to 15.2 km (0 to 50,000 ft)

Table A-45. RRD40 Compact Disc Drive Description (Tabletop)

	Weight	Height	Width	Depth
Expansion box	4.0 kg (8.8 lb)	76.2 mm (3 in.)	231.7 mm (9.125 in.)	279.4 mm (11 in.)

Table A-46. RRD40 Compact Disc Drive Specifications (Tabletop)

Capacity per disc	635 Mbytes
Access time	Maximum 1,000 Msec, including latency average 500 Msec
Average latency	155 Msec at outer track 60 Msec at inner track
Average transfer rate	175.2 Kbytes/sec
Initialization startup time	Less than 6 sec
Heat dissipation	14 watts (typical)

Table A-47. RRD40 Compact Disc Drive Operating Conditions (Tabletop)

Temperature range¹	10° C to 50° C (50° F to 122° F)
Relative humidity	10% to 80%, noncondensing
Maximum wet-bulb temperature	28° C (82° F)
Minimum dew-point temperature	2° C (36° F)
Altitude	3400 m (11,150 ft) at 36° C (96° F)

¹Reduce maximum temperature by 1.8° C (3.24° F) for each 1,000-meter (3333.33 ft) increase in altitude.

Table A-48. RRD40 Compact Disc Drive Nonoperating Conditions (Tabletop)

Temperature range	4° C to 70° C (40° F to 158° F)
Relative humidity	5% to 95%, noncondensing
Maximum wet-bulb temperature	46° C (115° F), packaged
Minimum dew-point temperature	2° C (36° F)
Altitude	13,600 m (44,600 ft) at 36° C (96° F)

Table A-49. RZ23 SCSI Hard Disk Drive Description

	Weight	Height	Width	Depth
Internal drive	0.826 kg (1.82 lb)	41.28 mm (1.625 in.)	101.6 mm (4.00 in.)	146 mm (5.75 in.)

Table A-50. RZ23 SCSI Hard Disk Drive Specifications (formatted)

Capacity	104 Mbytes
- Per surface	13 Mbytes
- Per track	16,896 bytes
- Per block	512 bytes
Blocks	33 per track 204,864 per drive
Spare block	1 per track 6208 per drive
Transfer rate	1.25 Mbytes/sec to/from media 1.25 Mbytes/sec to/from buffer
Seek time	<= 8 Msec track-to-track <= 25 Msec average <= 45 Msec average
Average latency	8.4 Msec
Rotational speed	3,575 RPM +/- 0.1%
Start time	20 sec maximum
Stop time	20 sec maximum
Interleave	1:1

Table A-51. RZ23 SCSI Hard Disk Drive Operating Conditions

Temperature range	10° C to 60° C (50° F to 140° F)
Relative humidity	8% to 80%, noncondensing
Maximum wet-bulb temperature	26° C (78° F)
Minimum dew-point temperature	2° C (36° F)
Altitude	3,050 m (10,000 ft) at 36° C (96° F)

Table A-52. R223 SCSI Hard Disk Drive Nonoperating Conditions

Temperature range	- 40° C to 66° C (- 40° F to 151° F) per hour
Relative humidity	8% to 95%, packaged
Maximum wet-bulb temperature	46° C (115° F), packaged
Minimum dew-point temperature	2° C (36° F)
Altitude	- 305 m to 12,200 m (- 1,000 ft to 40,000 ft) at 36° C (96° F)

Table A-53. RZ23L SCSI Hard Disk Drive Description

	Weight	Height	Width	Depth
Internal drive	0.544 kg (1.2 lb)	25.64 mm (1.0 in.)	102.56 mm (4.00 in.)	147.44 mm (5.75 in.)

Table A-54. RZ23L SCSI Hard Disk Drive Specifications (formatted)

Capacity	121.65 Mbytes
- Per surface	30.41 Mbytes
- Per track	19,968 bytes
- Per block	512 bytes
Blocks	39 user plus 1 spare per track 237,588 per drive
Spare tracks	0
Spare blocks	6,092 per drive
Transfer rate	1.25 Mbytes/sec to/from media
Seek time	8 Msec track-to-track 19 Msec average <= 35 Msec average
Average latency	8.8 Msec
Rotational speed	3,409 RPM + 0.5%
Start time	20 sec maximum
Stop time	20 sec maximum
Interleave	1:1

Table A-55. RZ23L SCSI Hard Disk Drive Operating Conditions

Temperature range	10° C to 55° C (50° F to 128° F)
Relative humidity	8% to 80%, noncondensing
Maximum wet-bulb temperature	26° C (78° F)
Altitude	-305 m to 4,575 m (-1000 ft to 15,000 ft) at 36° C (96° F)

Table A-56. RZ23L SCSI Hard Disk Drive Nonoperating Conditions

Temperature range	- 40° C to 66° C (- 40° F to 151° F) per hour
Relative humidity	8% to 95%, packaged
Maximum wet-bulb temperature	46° C (115° F), packaged
Altitude	- 305 m to 12,200 m (- 1,000 ft to 40,000 ft) at 36° C (96° F)

Table A-57. RZ24 SCSI Hard Disk Drive Description

	Weight	Height	Width	Depth
Internal drive	.78 kg (1.7 lb)	81.6 mm (1.63 in)	102 mm (4.0 in)	293.25 mm (5.75 in)

Table A-58. RZ24 SCSI Hard Disk Drive Specifications

Capacity	209.7 Mbytes
– Per surface	26.2 Mbytes
– Per track	19,456
– Per block	512 bytes
Blocks	38 plus 1 spare per track 409.802 per drive
Spare blocks	10,944 per drive
Spare tracks	0
Transfer rate to/from media	1.05 Mbytes/sec
Bus asynchronous mode	3.0 Mbytes/sec
Bus synchronous mode	4.0 Mbytes/sec
Seek time	5 Msec track-to-track 16 Msec average 35 Msec maximum
Average latency	8.3 Msec
Rotational speed	3,497 +/- 0.5% RPM
Start time	20 sec maximum
Stop time	20 sec maximum
Interleave	1:1
Heat dissipation	6.6 watts seeking
Recording density at ID	31,800 bpi
Track density	1,700 tpi
Tracks/surface (formatted)	1,368
R/W heads	8

Table A-59. R224 SCSI Hard Disk Drive Operating Conditions

Temperature range ¹	10° C to 55° C (50° F to 131° F)
Relative humidity	8% to 80%
Maximum wet-bulb temperature	25.6° C (78° F)
Minimum dew-point temperature	2° C (36° F)
Altitude	- 304 to 4,600 m (- 1,000 ft to 15,000 ft) at 36° C (96° F)

¹Reduce maximum temperature by 1.8° C (3.24° F) for each 1,000-meter increase in altitude.

Table A-60. R224 SCSI Hard Disk Drive Nonoperating Conditions

Temperature range	- 40° C to 66° C (- 40° F to 151° F)
Relative humidity	20% to 95%, packaged (noncondensing)
Maximum wet-bulb temperature	46° C (115° F), packaged (noncondensing)
Minimum dew-point temperature	2° C (36° F)
Altitude	- 304 to 12,300 m (- 1,000 ft to 40,000 ft) at 36° C (96° F)

Table A-61. RX23 Floppy Disk Drive Description

	Weight	Height	Width	Depth
Internal drive	0.480 kg (1.06 lb)	30. mm (1.18 in.)	101.6 mm (4.0 in)	150 mm (5.91 in)

Table A-62. RX23 Floppy Disk Drive Specifications (formatted)

Capacity	
- Per drive	737 Kbytes (double) 1,474 Kbytes (high)
- Per surface	368 Kbytes (double) 737 Kbytes (high)
- Per track	4.61 Kbytes (double) 9.22 Kbytes (high)
- Per block	512 bytes
Blocks	9 (double) per track 18 (high) per track 1,440 (double) per drive 2,880 (high) per drive
Transfer rate	250 Kbytes/sec (double) to/from media 500 Kbytes/sec (high) to/from media
Seek time	<= 3 Msec minimum, track-to-track <= 94 Msec average
Average latency	100 Msec
Rotational speed	300 rpm
Start time	700 Msec maximum
Operating power	3.0 watts
Standby power	0.3 watts
Voltage	5.0 Vdc/12.0 Vdc

Table A-63. RX23 Floppy Disk Drive Operating Conditions

Temperature range	5° C to 50° C (40° F to 122° F)
Relative humidity	8% to 80%, noncondensing
Maximum wet-bulb temperature	25.6° C (78° F)
Altitude	- 304 to 3,060 m (- 1,000 ft to 10,000 ft)

Table A-64. RX23 Floppy Disk Drive Nonoperating Conditions

Temperature	- 40° C to 66° C (- 40° F to 151° F)
Relative humidity	5% to 95%, packaged
Maximum wet-bulb temperature	46° C (115° F), packaged
Altitude	- 304 to 12,300 m (- 1,000 ft to 40,000 ft) at 36° C (96° F)

Part Numbers**Table B-1. Basic Components**

Item	Order Number
15-inch monochrome monitor, 120 volts	VR150-AA
15-inch monochrome monitor, 240 volts	VR150-A3
15-inch color monitor, 120 volts	VR160-DA
15-inch color monitor, 240 volts, Northern Hemisphere	VR160-D3
15-inch color monitor, 240 volts, Southern Hemisphere	VR160-D4
19-inch monochrome monitor, 120 volts	VR262-AA
19-inch monochrome monitor, 240 volts	VR262-A3
16-inch color monitor, 120 volts	VR297-DA
16-inch color monitor, 240 volts, Northern Hemisphere	VR297-D3
16-inch color monitor, 240 volts, Southern Hemisphere	VR297-D4
19-inch color monitor, 120 volts	VR299-DA
19-inch color monitor, 240 volts, Northern Hemisphere	VR299-D3
19-inch color monitor, 240 volts, Southern Hemisphere	VR299-D4
External disk drive, 332 Mbytes, 120 volts	RZ55-FA
External disk drive, 332 Mbytes, 240 volts	RZ55-F3
Optical compact disc drive, 600 Mbytes, 120 volts	RRD40-FA
Optical compact disc drive, 600 Mbytes, 240 volts	RRD40-F3
Internal disk drive, 104 Mbytes	RZ23-FF

(continued on next page)

Table B-1 (Cont.). Basic Components

Item	Order Number
Internal disk drive, 121 Mbytes	RZ23L-FF
Internal disk drive, 209 Mbytes	RZ24-FF
Internal floppy disk drive, (floppy panel)	RX23-EH
Memory expansion	MS01-AA
Monochrome video SIM module	VFB01
Color video SIM module	VFB02
Tape drive, 95 Mbytes, 120 volts	TK50Z-GA
Tape drive, 95 Mbytes, 240 volts	TK50Z-G3
Tape drive, 2.2 Gbytes, 120 volts	TKZ08-AA
Tape drive, 2.2 Gbytes, 240 volts	TKZ08-A3
Cassette tape drive, 1.2 Gbytes, 120 volts	TLZ04-DA
Mouse	VSXXX-AA

Table B-2. BA42 Storage Expansion Box Configuration

Expansion Box Configuration	Order Number	
	120 Volt	240 Volt
Single RZ55	SZ12A-XA	SZ12A-XB
Double RZ55	SZ12A-AA	SZ12A-AB
Single RZ56	SZ12B-XA	SZ12B-XB
Double RZ56	SZ12B-BA	SZ12B-BB
Single RZ57	SZ12C-XA	SZ12C-XB
Double RZ57	SZ12C-CA	SZ12C-CB
Single RZ55, single RX23	SZ12A-LA	SZ12A-LB
Single RZ55, single RX33	SZ12A-MA	SZ12A-MB
Single RZ55, single TZ30	SZ12A-HA	SZ12A-HB
Single RZ55, single TZK10	SZ12A-EA	SZ12A-EB
Single RZ56, single TZ30	SZ12B-HA	SZ12B-HB
Single RZ56, single TZK10	SZ12B-EA	SZ12B-EB
Single RZ57, single TZK10	SZ12C-EA	SZ12C-EB
Single RX23	SZ12X-LA	SZ12X-LB
Single RX33	SZ12X-MA	SZ12X-MB
Single TZ30	SZ12X-HA	SZ12X-HB
Single TZK10	SZ12X-EA	SZ12X-EB

Table B-3. Cords, Cables, and Connectors

Item	Part Number	Order Number
Expansion box power cord	17-00606-10	—
Monitor-system unit cable (US)	17-00442-26	—
Power supply to internal disks cable	17-02225-01	—
SCSI cover	74-38189-01	—
SCSI 68-pin terminator	12-29635-01	—
SCSI internal cable (DECstation 2100/3100 only)	17-02358-01	—
SCSI internal cable (DECstation 3100S only)	17-02358-02	—
Serial line cable	—	BC16E-10
System unit power cord (U.S.)	17-00606-10	—
ThickWire cable	—	BNE4C-02
ThickWire loopback connector	12-22196-01	—
ThinWire T-connector	12-25534-01	H8223
ThinWire terminator	12-25535-01	H8225
ThinWire cable (12 ft)	17-01241-09	BC16M-12
ThinWire LAN assembly kit	22-00112-01	BC16T-12
Video cable, monochrome	17-01993-01	BC23K-03
Video cable, color	17-01992-01	BC23J-03
68-pin to 50-pin system unit-expansion box SCSI cable	17-02008-01	BC56H-03 Rev. B01
18-inch 50-pin to 50-pin SCSI cable	17-01351-04	BC19J-1E
36-inch 50-pin to 50-pin SCSI cable	17-01351-01	BC19J-03
50-pin SCSI terminator for expansion box	12-30552-01	—
25-pin (F) to 6-pin (F) MMJ adapter	12-23599-01	H8571-A
or	—	H8571-F

Table B-4. Software Documentation

Item	Order Number
ULTRIX Media and Doc-TK50	QA-VV1AA-H5
<i>Technical Summary for RISC Processors</i>	AA-MM35A-TE
<i>Documentation Overview for RISC Processors</i>	AA-MM05A-TE
<i>Start-up Instructions for Factory-Installed Software on DECstations 2100/3100</i>	EK-INFIS-IS
<i>Guide to SCAMP for Workstations</i>	EK-SCAMP-UG

Table B-5. Hardware Documentation

Item	Order Number
DECstation 2100/3100 User Documentation Kit	EK-308AB-DK
<i>DECstation 2100/3100 Maintenance Guide</i>	EK-291AB-MG
<i>DECstation 2100/3100 Hardware Installation Guide</i>	EK-290AB-IN
<i>DECstation 2100/3100 Operator's Guide</i>	EK-302AB-OG
Components and Add-Ons	
<i>The RZ22/23 Disk Drive Service Manual</i>	EK-RZ223-SV
<i>The RX23 Diskette Drive Subsystem Service Manual</i>	EK-RX23D-SV
<i>The RZ55 Disk Drive Service Manual</i>	EK-RZ55D-SV
<i>The RZ56 Disk Drive Subsystem Service Manual</i>	EK-RZ56D-SV
<i>The RZ57 Disk Drive Subsystem Service Manual</i>	EK-RZ57D-SV
<i>The TZK10 Cartridge Tape Drive Owner's Guide</i>	EK-TZK10-OG
<i>Installing and Using the LN03</i>	FK-0LN03-UG
<i>LN03 PLUS User Guide</i>	EK-LN03S-UG
<i>ScriptPrinter Installation Guide</i>	EK-LN03R-UG
<i>ScriptPrinter Operator Guide</i>	EK-LN03R-OG
<i>LA100 Letterwriter User Documentation Kit</i>	EK-LW100-UG
<i>Installing and Using the LA75 Companion Printer</i>	EK-0LA75-UG
<i>Installing and Using the LJ250/252 Companion Color Printer</i>	EK-LJ250-DK
<i>TK50Z Tape Drive Subsystem Owner's Manual</i>	EK-LEP05-OM
<i>TK50Z User's Guide</i>	EK-OTK50-UG
<i>TLZ04 Cassette Tape Drive Owner's Manual</i>	EK-TLZ04-OM
<i>BA42 Storage Expansion Box Installation Guide</i>	EK-BA42A-IN

Console Commands

Your workstation functions in two modes: program I/O mode and console I/O mode. Program I/O mode is the normal operating mode in which you interact with your terminal. Console I/O mode allows low-level communication between the user and DECstation 2100/3100 hardware. You can use it for such operations as booting the operating system, setting up automatic booting, setting baud rates, and examining memory.

On power up, your workstation automatically enters console mode after the self-test completes, unless you have programmed automatic boot-strapping. You can also invoke the console program by halting the operating system.

The console program displays the prompt >> when it is ready to accept commands. Observe the following rules when typing console commands:

- All commands typed at console level are case sensitive. The workstation does not recognize uppercase and lowercase letters as the same input.
- Command execution begins when you press the Return key.
- Enter numeric values as follows:
 - Enter *decimal values* as a string of decimal digits with no leading zeros (for example, 123).
 - Enter *octal values* as a string of octal digits with a leading zero (for example, 0177).
 - Enter *hexadecimal values* as a string of hexadecimal digits preceded by 0x (for example, 0x3ff).
 - Enter *binary values* as a string of binary digits preceded by 0b (for example, 0b1001).
- When reading or writing to memory, you have a choice of data sizes: byte, halfword, or word. Because a word is 4 bytes, successive addresses, when referenced by a word, are successive multiples of 4. For example, the address following 0x80000004 is 0x80000008. An error will occur if you try to specify an address that is not on a boundary for the data size you are using.
- The following key combinations have an immediate effect in console mode:
 - Ctrl-S stops output to the screen.
 - Ctrl-Q resumes output to the screen.
 - Ctrl-C aborts execution of a command.
 - Ctrl-U erases a partially typed command line.

Conventions Used in This Appendix

- Letters in roman type are to be typed exactly as they appear.
- Letters in italics represent arguments for which you supply values. (Note that your help and menu screens display these arguments in all capital letters.)
- Arguments enclosed in square brackets ([]) are optional.
- Ellipses (...) follow an argument that can be repeated.
- A vertical bar (|) separates choices. You can think of it as a symbol meaning *or*.
- Parentheses are used as in algebraic expressions. For example,

`-(b | h | w)`

means enter -b or -h or -w.

Getting Help

You can get help with console command syntax in several ways:

- You can type the word **help** or a question mark (?) to display a menu of all console commands.
- You can enter the name of the command for which you want help as an argument to help or ?.

For example, entering ? e at the console prompt (>>) displays the syntax for the examine (e) command:

```
e [- (b|h|w)] ADDR  
>>
```

- If you type an incorrect command line, you get a help screen.

For example, the e command requires an *addr* argument. Typing e -b at the console prompt (>>) without entering an address causes the screen to display the correct syntax for the command:

```
e [- (b|h|w)] ADDR  
>>
```

Console Commands

Table C-1 lists the console commands.

Table C-1. Console Commands

Command	Description
auto	Starts automatic bootstrapping.
boot	Boots the operating system.
ctrs	Displays network counters.
d	Deposits data at a given address.
disable	Disables a device.
dump	Dumps memory to the screen.
e	Examines memory.
enable	Enables a device.
fill	Deposits data in an address range.
go	Resumes execution of the program in memory.
help	Displays the syntax of console commands.
?	Displays the syntax of console commands.
init	Reinitializes memory.
passwd	Sets and clears the system password.
printenv	Displays console environment variables.
setenv	Sets console environment variables.
test	Runs tests or displays the system configuration.
unsetenv	Unsets console environment variables.

In addition to the commands described in Table C-1, two other commands—**cat** and **warm**—also show on the help menu. These commands are not supported at this time.

Commands, such as the **scsi** and **t** commands, that do not appear on the help menu are documented in the *DECstation 2100/3100 Maintenance Guide*.

The auto Command

auto

This command starts the automatic bootstrapping sequence that puts the workstation into multiuser mode (the normal time-sharing environment).

The workstation boots according to the *bootpath* variable stored in the environment variables table.

Execution is delayed for 5 seconds after you press Return. To abort the auto command, you can type Ctrl-C during this 5-second delay.

The boot Command

```
boot [-f file] [-n] [arg...]
```

This command loads the file that contains the operating system.

- The optional *-f* flag followed by the *file* parameter specifies the file you want to use during a boot procedure. If you do not specify the *-f* flag and a file, the file specified by the environment variable *bootpath* is loaded.

The *file* parameter has the format

```
dev([controller],[unit-number] [,partition-number])[filename]
```

- *dev* indicates the device from which you are booting the operating system. Typical devices are *rz* for a hard disk, *tz* for a tape, and *mop* for a network. Typing *mop* nullifies the other arguments in the list, so that *file* takes the form *mop*().
- *controller* indicates the ID number of the default controller. On the DECstation 2100/3100 workstation, this number is always 0.

- *unit-number* indicates the unit number of the device from which you are booting the operating system. To display a list of devices and their unit numbers, enter `test -c` at the console prompt (`>>`).
- *partition-number* indicates the number (or other designator) of the partition from which you are booting the operating system. When booting from a tape, this number is not used because the boot file must be the first thing on the tape. When booting from a disk, this number depends on how you partitioned the disk when you installed your operating system software. Refer to your software installation manual if you need a reminder about disk partition indicators.
- *file name* indicates the name of the operating system file.
 - The optional `-n` flag causes the specified file to be loaded but not executed.
 - The optional *arg* parameter contains any information to be passed to the booted image.

Examples:

```
>> boot -f rz(0,0,0)vmunix
```

This command boots the file `vmunix`, located in the `A` partition of the first hard disk (unit number 0), using controller, 0.

```
>> boot -f rz(0,4,c)vmunix
```

This command boots the file `vmunix` from the optical compact disc drive, which is unit 4 in this example.

```
>> boot -f tz(0,5)
```

This command boots from the tape, which is unit 5 in this case.

The `ctrs` Command

`ctrs`

This command displays all the network counters.

A typical display looks like this:

```
15905 : seconds since zeroed
  0 : bytes received
  0 : bytes sent
  0 : frames received
  0 : frames sent
  0 : multicast bytes received
  0 : multicast frames received
  0 : frames sent deferred
  0 : frames sent, single collision
  0 : frames sent, multiple collision
  0 : send failures
  0 : send failure bitmap
  0 : receive failures
  0 : receive failure bitmap
  0 : unrecognized destinations
  0 : data overruns
  0 : unavailable system buffers
  0 : unavailable user buffers
```

Note: *The counter values will not be zero after an ethernet boot.*

The **d** (deposit) Command

d [-(**b** | **h** | **w**)] *addr val*

This command deposits a single byte, halfword, or word value at the specified address.

The first parameter, which is optional, indicates the data size. If not given, data size defaults to word. If you do not specify a data size, a word is used.

- Use **-b** to deposit 1 byte of data
- Use **-h** to deposit a halfword (2 bytes) of data
- Use **-w** to deposit a word (4 bytes) of data

The *addr* parameter indicates the address to which you want data written. System address space ranges from 0x80000000 to 0xBF000000.

The *val* parameter contains the data you want deposited at the given address.

Example:

```
>> d -w 0x80000000 0xFFFFFFFF
```

This command deposits the value 0xFFFFFFFF, with a data size of one word, at address 0x80000000.

The `disable` Command

`disable [dev]`

This command disables the connection to a specified device. It also removes the device from the list of recognized console terminals stored in volatile memory.

The optional *dev* parameter indicates the device you are disabling. If you do not specify *dev*, `disable` displays the list of currently enabled console devices. The *dev* parameter has the format `tty(n) | crt(0)`.

- `tty(n)`, where *n* is a serial line, specifies a printer, console, or communications device.

Specify 2 for a communications connector and 3 for a printer/console connector.

For example, to disable an alternate console, enter

```
disable tty(3)
```

- `crt(0)` specifies the workstation monitor.

The `dump` Command

`dump [-b | h | w] [-o | d | u | x | c | B] rng`

This command shows a formatted display of the contents of memory.

The first parameter, which is optional, indicates the data size. If not given, data size defaults to word. If you do not specify a data size, the system uses a word.

- `-b` displays memory in bytes.
- `-h` displays memory in halfwords.
- `-w` displays memory in words.

The *next* parameter, also optional, determines how data is displayed.

- **-o** displays memory in octal format.
- **-d** displays memory in decimal format.
- **-u** displays memory in unsigned decimal format.
- **-x** displays memory in hexadecimal format.
- **-c** displays memory in ASCII format.
- **-B** displays memory in binary format.

If no format argument is given, hexadecimal format is used.

The *rng* parameter indicates the range of memory you want to see. You can specify the range in one of two ways:

- *addr#cnt* displays the number of addresses specified by *cnt*, beginning at *addr*.
- *addr:addr* displays all values between the specified addresses.

Examples:

```
>> dump 0x80000000#0xf
```

This command uses hexadecimal format to dump the first 15 words of memory to the screen.

```
>> dump -b 0x80000000#0xf
```

This command uses hexadecimal format to dump the first 15 bytes of memory to the screen. The dump display shows rows of address contents. The left-most column gives the address of the first field in each row.

The **e** (examine) Command

e [-(**b** | **h** | **w**)] *addr*

This command examines the byte, halfword, or word at the specified address.

The first parameter, which is optional, indicates the data size. If not given, data size defaults to word. If you do not specify the data size, a word is used.

- **-b** indicates a single byte.
- **-h** indicates a halfword.
- **-w** indicates a word.

The *addr* parameter indicates an address in the range 0x80000000 to 0xBF000000.

When you enter the examine command, a display similar to the following appears:

```
0x80000005: 65 0x41 'A'
```

The left-most field echoes the address you entered.

The next three fields display the contents of the address in decimal, hexadecimal, and ASCII formats, respectively. If the ASCII character is unprintable, it is displayed as an octal value preceded by a backslash: for example, '\032'.

Example:

```
>> e 0x80000000
```

This command examines the word at address 0x80000000. The resulting display might look like this:

```
0x80000000: 1008385985 0x3c1abfc1 '\301'
```

The **enable** Command

enable [*dev*]

This command enables the connection to a specified device. It also adds the device to the list of current console devices stored in volatile memory.

The optional *dev* parameter indicates the device you are enabling. If you do not specify *dev*, **enable** displays the list of currently enabled console devices. The *dev* parameter has the format **tty** (*n*) | **crt**(0)

- **tty**(*n*), where *n* is a serial line, specifies a printer, console, or communications device.

Specify 2 for a communications connector and 3 for a printer/console connector.

For example, to enable an alternate console, enter **enable tty(3)** at the console prompt (>>).

- **crt**(0), specifies the workstation monitor.

You can enable more than one device as a console device.

The fill Command

```
fill [-(b | h | w)] [-v val] rng
```

This command writes a specified value to a range of memory. If you do not specify a value, the workstation puts zeros in the memory range.

The first parameter, which is optional, indicates the data size. If not given, data size defaults to word.

- **-b** indicates bytes.
- **-h** indicates halfwords.
- **-w** indicates words.

The optional parameter **-v *val*** specifies the numeric value to write to memory. If you do not specify a value, all zeros are written. If the size of *val* does not match the data size parameter, *val* is truncated or expanded as necessary.

The *rng* parameter indicates the memory range. You can specify the range in one of two ways:

- ***addr#cnt*** fills addresses beginning at *addr* and continuing for *cnt* locations.
- ***addr:addr*** fills all locations between the two given addresses.

Example:

```
>> fill -v 0xffffffff 0x80000010:0x800000ff
```

This command sets all bits to 1 at addresses 16 to 255.

The go Command

`go [pc]`

This command transfers control to the indicated entry-point address.

The optional *pc* parameter indicates the entry-point address you want to use.

If you do not specify an entry-point address, the workstation uses the entry point of the program module that was most recently loaded. If no program module was previously loaded, the workstation uses 0 as the entry-point address.

The help Command

`help [cmd]`

This command displays the correct syntax for the console commands.

The optional *cmd* parameter indicates the command for which you want information. If you do not specify *cmd*, the complete console menu appears.

The ? Command

`? [cmd]`

This command functions exactly like the help command.

The `init` Command

`init`

This command fully initializes the system.

The effect of the `init` command is identical to turning the power on or pressing the reset button, except that the workstation does not execute its self-test.

The `passwd` Command

`passwd`

This command, which is not available on all systems, allows you to use only the boot and password commands until you enter the password. A system that requires a password before you can use all console commands displays the prompt `s>` until you enter the password.

To enter a password, type `passwd` at the prompt `s>`. Then type the password and press Return. Whenever all console commands are available, the system displays the prompt `>>`.

To set or change a password,

1. Type `passwd -s` at the prompt `>>` and press Return.
2. At the prompt `pwd:`, type the new password and press Return.
3. The system then repeats the prompt `pwd:`. Enter the password a second time at the prompt `pwd:`.

Note that passwords must

- Have at least 6 but no more than 32 characters
- Use the same uppercase and lowercase letters used when you first entered the password

If the two password entries match, the entry becomes the new password. If the two entries do not match, the old password remains in effect.

To remove a requirement for a password, type **passwd -c** at the prompt **>>** and press Return.

The printenv Command

```
printenv [var...]
```

This command displays the current value for the specified environment variable.

The optional *var* parameter indicates the variable whose value you want to see. If you do not specify a variable, the complete environment variables table appears. A typical display looks like this:

```
baud2=1200
baud3=9600
bootpath=
bootmode=*
console=0
kbd=4
scsiid0=6
systype=0x82011601
bitmap=0xa000fcc0
bitmaplen=0xc0
inetaddr=0
osconsole=1
```

There are three types of variables: volatile (lost when power resumes), nonvolatile (maintained after power resumes), and fixed (rebuilt when power is turned on). Table C-2 lists the default variables.

Table C-2. Default Environment Variables

Variable	Type	Description
<i>baud2</i>	Nonvolatile	Indicates the baud rate of the communications connector.
<i>baud3</i>	Nonvolatile	Indicates the baud rate of the printer/console connector.
<i>bootpath</i>	Nonvolatile	Indicates the default bootpath. The workstation uses this variable when you type the auto command.
<i>bootmode</i>	Nonvolatile	Determines what programs run when the workstation is turned on or reset. Use one of the following codes: <ul style="list-style-type: none">* The default code; makes the console program active on the workstationa Boots the operating system using the <i>bootpath</i> variabled Resets the workstation without running the self-testr Restarts the workstation

(continued on next page)

Table C-2 (Cont.). Default Environment Variables

Variable	Type	Description
<i>console</i>	Nonvolatile	<p>Determines which device is used for the console when the workstation is started. Use one of the following values to set this variable:</p> <ul style="list-style-type: none">0 Lets the system choose the console device.1 Specifies the workstation monitor, crt(0), and the keyboard connector, tty(0).4 Specifies the communications connector, tty(2).8 Specifies the printer/console connector, tty(3).9 Specifies the workstation monitor, crt(0); the keyboard connector, tty(0); and the printer/console connector, tty(3).
<i>kbd</i>	Nonvolatile	<p>Contains the keyboard code. A total of 16 different keyboard codes are supported. Valid values are 1 to 16.</p>
<i>scsiid0</i>	Nonvolatile	<p>Contains the SCSI ID of the processor. Valid values are 0 to 7. Values other than the default (6) are needed only for unusual SCSI bus configurations.</p>

(continued on next page)

Table C-2 (Cont.). Default Environment Variables

Variable	Type	Description
<i>systype</i>	Fixed	A value taken from the hardware register in the central processing unit. Do not change this variable.
<i>bitmap</i>	Fixed	Indicates the address of the memory bitmap. The bitmap keeps track of good and bad memory pages. Each bit corresponds to one page in memory; 1 indicates the page is good, and 0 indicates the page is bad. Do not change this variable.
<i>bitmaplen</i>	Fixed	Indicates the length of the memory bitmap. Do not change this variable.
<i>inetaddr</i>	Volatile	Indicates the workstation's internet address. This variable is used by the Ethernet driver.
<i>osconsole</i>	Volatile	Set by the system power up to indicate which device the workstation selected as the console. Values have the same meaning as for the <i>console</i> variable. The <i>osconsole</i> and <i>console</i> variables have the same value except when <i>console</i> is 0 or set to a value the system cannot use.

The **setenv** Command

setenv *var str*

This command assigns new values to the specified environment variable. Refer to the discussion of the **printenv** command for a description of each variable.

- The *var* parameter indicates the variable you want to set.
- The *str* parameter indicates the value you want to specify.

You can also add your own environment variables. These variables are stored in volatile memory. The environment variables table can contain up to 16 variables, for a total of 256 characters.

The **test** Command

test *arg*

This command allows you to run the self-test or display the current configuration table.

The *arg* parameter has the following format:

-(a/c)

- Specify **-a** runs the self-test. This self-test is similar to the power-up self-test.
- Specify **-c** displays the configuration table. The configuration table provides such information as how much memory is installed, whether a monochrome or color video SIM module is part of your workstation, and what kind of disk or tape storage device is connected to your system.

The following is a typical configuration table:

```
MEM: 16Mbytes
VIDEO: MONO
ETHERNET STA ADDR: 08-00-2b-0c-4a-8b
SCSI DEVS:
U[7]
U[6]KN01--SII
U[5]
U[4]
U[3]
U[2]
U[1]
U[0] Dev typ 0 RZ
      RMB          0x0
      Vrs          1
      Format       1 CCS
      Add len     31
      Vndr        DEC
      PID         RZ23 (C) DEC
      Frlvl       0618
```

The unsetenv Command

This command removes the specified variable from the environment variables table.

```
unsetenv var
```

The *var* parameter indicates the variable you are removing. Refer to Table C-2 earlier in this appendix for a description of each variable.

The `unsetenv` command does not affect the environment variables stored in nonvolatile memory. These variables are reset at the next reset or power cycle.

Interpreting the Self-Test

This appendix tells you how to interpret power-up self-test codes displayed on the monitor screen and in the LED status display on the back of the system unit.

Using the Power-Up Self-Test

There are two ways to interpret self-test results when a test fails:

- You can use the test codes displayed on the monitor.
- You can use the LED codes that appear on the LED status display on the back of the system unit.

Use the LED display when you cannot use the monitor to read the test codes.

Interpreting Monitor Self-Test Codes

If a subtest fails and the results are displayed on your screen, the number of the subtest that failed is the last number displayed.

Use Table D-1 to determine where the error occurred and what action to take.

Table D-1. Monitor Self-Test Display Codes

Test Code	Component Tested	Action to Take if Subtest Fails
7	Video single in-line memory (video SIM) module	Contact your Digital service representative.
6	VDAC and PCC	Contact your Digital service representative.
5	DZ serial line	Contact your Digital service representative.
4	System module	Follow the SCSI troubleshooting procedures described in Chapter 7 of this guide.
3	Keyboard and mouse	Follow the keyboard and mouse troubleshooting procedures described in Chapter 7 of this guide.
2	Network interface (LANCE)	Follow the Ethernet troubleshooting procedures described in Chapter 7 of this guide.
1	Disk and SCSI bus peripherals	Contact your Digital service representative.
0	Indicates the end of the test	None; the system test has succeeded.

Interpreting LED Self-Test Codes

If a subtest fails, the red lights glow on the LED status display on the back of the system unit. The configuration of the lights indicates the subtest that failed.

To interpret self-test results without using a monitor, use Table D-2 to determine where the error occurred and what action to take. The binary codes in the LED display column reflect the red status LED display as viewed from the back of the system unit.

Table D-2. LED Self-Test Display Codes

LED Display (1 = LED on, 0 = LED off)	Hexadecimal Code	Component Tested	Action to Take if Subtest Fails
0111 1111	7f	System module	Contact your Digital service representative.
1011 1111	bf	Disk	Follow the SCSI troubleshooting procedures described in Chapter 7 of this guide.
1101 1111	df	Keyboard	Follow the keyboard trouble- shooting procedures described in Chapter 7 of this guide.
1110 1111	ef	Memory	Contact your Digital service representative.
1111 0111	f7	Mouse	Follow the mouse troubleshoot- ing procedures described in Chapter 7 of this guide.
1111 1111	ff	LEDs set at power up or reset	Contact your Digital service representative.