

PDP-11/23B Mounting Box User's Guide

PDP-11/23B Mounting Box User's Guide

Prepared by Educational Services
of
Digital Equipment Corporation

Copyright © 1982 by Digital Equipment Corporation
All Rights Reserved

The material in this manual is for informational purposes and is subject to change without notice.

Digital Equipment Corporation assumes no responsibility for any errors which may appear in this manual.

Printed in U.S.A.

The manuscript for this book was created on a DIGITAL Word Processing System and, via a translation program, was automatically typeset on DIGITAL's DECset-8000 Typesetting System. Book production was done by Educational Services Development and Publishing in Marlboro, MA.

The following are trademarks of Digital Equipment Corporation:

DEC	EduSystem	RSTS
DECnet	IAS	RSX
DECUS	MASSBUS	TOPS-10
DECsystem-10	MINC-11	TOPS-20
DECSYSTEM-20	OMNIBUS	UNIBUS
DECwriter	OS/8	VAX
DIBOL	PDP	VMS
digital	PDT	VT

CONTENTS

CHAPTER 1 INTRODUCTION

1.1	GENERAL.....	1-1
1.2	BA11-S APPLICATIONS.....	1-3
1.3	H9276 BACKPLANE.....	1-7
1.4	MODULE LOADING OF THE EXTENDED LSI-11 BUS.....	1-8
1.5	PDP-11/23B MOUNTING BOX SPECIFICATIONS.....	1-10
1.6	RELATED DOCUMENTS.....	1-13

CHAPTER 2 UNPACKING, INSTALLATION, AND OPERATION

2.1	UNPACKING.....	2-1
2.2	INSTALLATION.....	2-1
2.2.1	Preliminary Checks.....	2-1
2.2.1.1	AC Voltage Selection.....	2-1
2.2.1.2	Backplane Jumper Positions.....	2-1
2.2.1.3	Bezel Assembly Jumper Positions.....	2-3
2.2.1.4	Power Controller Cable Installation.....	2-4
2.2.1.5	Module Insertion and Removal.....	2-4
2.2.1.6	Module Installation.....	2-5
2.2.2	Mounting the Logic Box Cover in an Equipment Rack.....	2-6
2.2.3	Installing the Logic Box Base in the Cover.....	2-10
2.2.4	Power Connections.....	2-11
2.2.5	Installation Checks.....	2-12
2.3	OPERATION.....	2-12

FIGURES

Figure No.	Title	Page
1-1	PDP-11/23B Subsystem.....	1-1
1-2	BA11-S with Control Panel and Blank Front Panel.....	1-2
1-3	BA11-S Logic Box, Cover Removed.....	1-4
1-4	BA11-S, Rear View.....	1-5
1-5	BA11-S Typical System Application (PDP-11/23B).....	1-5
1-6	BA11-S System Application (PDP-11/23A).....	1-6
1-7	H9276 Backplane Connectors (Module Side).....	1-8
1-8	KDF11-A and KDF11-B Configuration Comparison.....	1-9
1-9	AC Loading Violation.....	1-10
1-10	H7861 Power Supply Minimum Ride-Through After Power Interruption.....	1-13
2-1	BA11-S Voltage Selection Switch.....	2-2
2-2	Backplane Jumpers.....	2-2
2-3	Front Panel Bezel Printed Circuit Board.....	2-3
2-4	Insertion and Removal of Modules with Extractor-Type Handles.....	2-5
2-5	BA11-S Cover Mounting Dimensions.....	2-6
2-6	BA11-S Unit Assembly Drawing.....	2-7
2-7	Power Connections, PDP-11/23B.....	2-11
2-8	Front Panel Switches and Indicators.....	2-12

TABLES

Table No.	Title	Page
1-1	PDP-11/23B Fully Compatible H9276 Backplane Options	1-6
1-2	BA11-S Mounting Box Specifications	1-11
1-3	BA11-S/H7861 Power Supply Specification.....	1-12
2-1	Backplane Jumpers	2-3
2-2	Bezel Assembly Jumpers	2-4
2-3	Parts List.....	2-8
2-4	Extended LSI-11 Bus Expansion Cable Assemblies (PDP-11/23B)	2-10
2-5	BA11-S Front Panel Switches and Indicators.....	2-13

CHAPTER 1 INTRODUCTION

1.1 GENERAL

The PDP-11/23B mounting box subsystem consists of three main parts: a BA11-S mounting box, a KDF11-B microprocessor, and an MSV11-P memory.

The PDP-11/23B mounting box subsystem can be installed in a standard 48.3 cm (19 in) wide equipment rack and is approximately 13.2 cm (5-3/16 in) high and 57.8 cm (22-3/4 in) deep. The PDP-11/23B subsystem consists of a BA11-S mounting box, two fans, an ac input unit, a power supply and a nine-slot backplane that accepts both double- and quad-height LSI-11 modules. The PDP-11/23B mounting box subsystem has a control panel that is equipped with operating switches and indicators. Systems having a multibox configuration use BA11-S mounting boxes with blank front panels for system expansion. Figure 1-1 shows the PDP-11/23B subsystem tree with the different supporting sub-assemblies. Figure 1-2 shows the PDP-11/23B mounting box subsystem with a control panel and an expansion box with a blank panel.

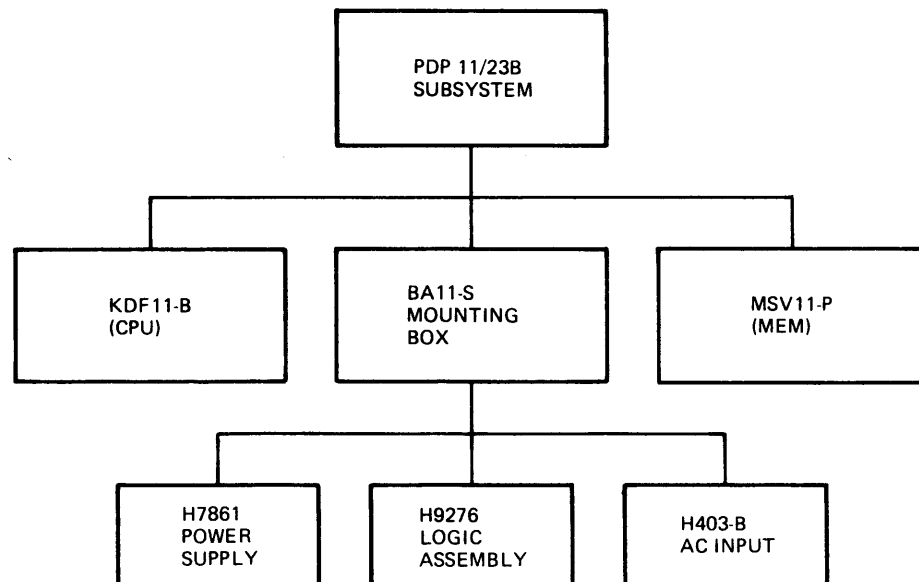

MR-6533

Figure 1-1 PDP-11/23B Subsystem

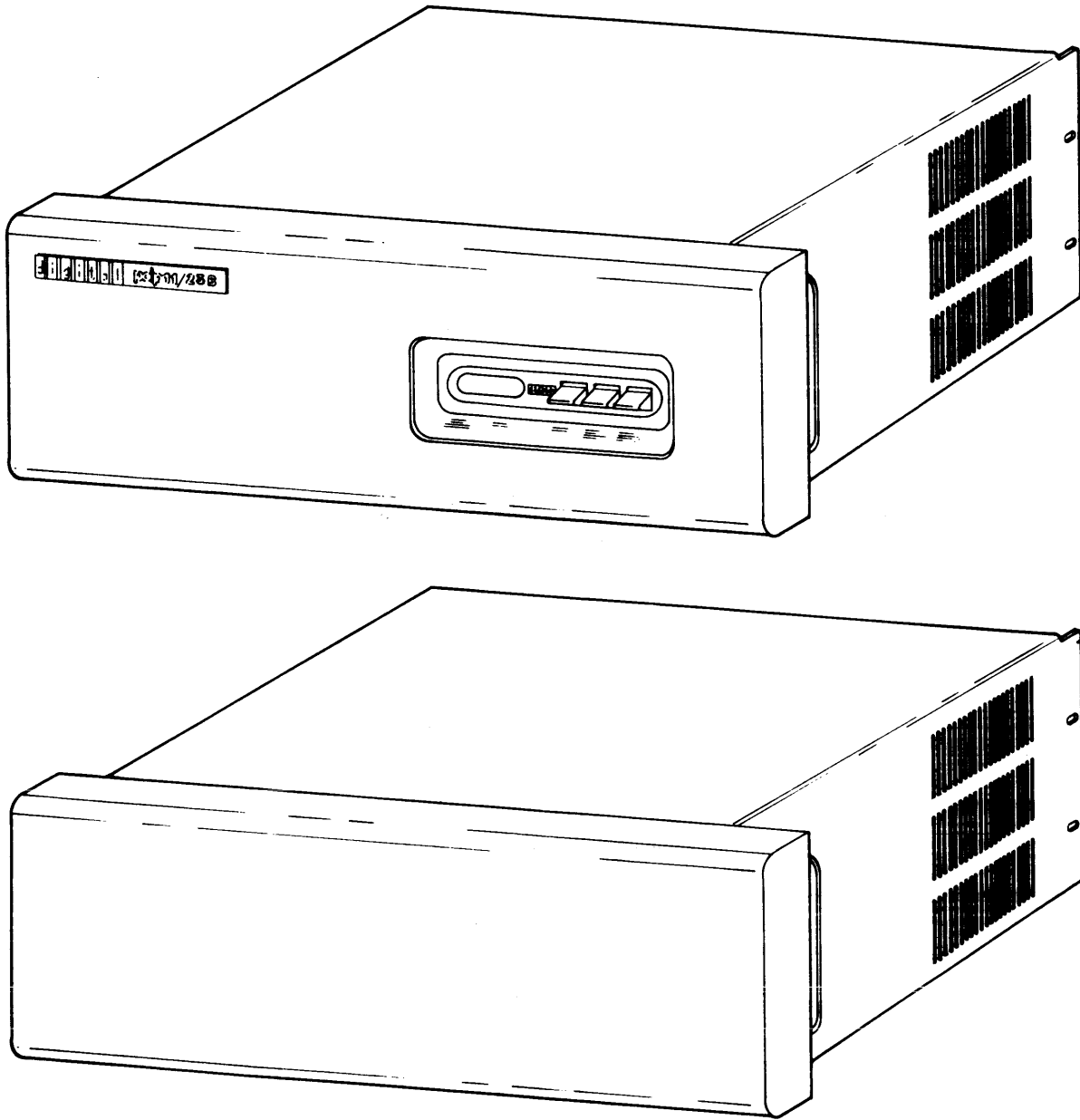

MR-6534

Figure 1-2 BA11-S with Control Panel and Blank Front Panel

The H9276, a 9 × 4 backplane, can accommodate both dual- and quad-height LSI-11 modules for use in the 22-bit addressing system.

The KDF11-B is a quad-height LSI-11 microprocessor (M8189) that includes a central processor, memory management unit, a line frequency clock, a BDV11-compatible boot-ROM/diagnostic ROM, and two serial line units. Three 40-pin IC sockets are provided for floating point (FP) and commercial instruction set (CIS) options.

The MSV11-P memory module (M8067) supports the KDF11-B microprocessor with memory storage in three sizes as follows:

MSV11-PF	128Kb (16K RAM)
MSV11-PK	256Kb (64K RAM)
MSV11-PL	512Kb (64K RAM)

The MSV11-P supports the extended LSI-11 bus which is a 22-bit address bus used with the KDF11-B system.

The BA11-S mounting box subsystem includes an H9276 logic assembly, two fans (a 70 cfm fan to cool the logic boards and a 100 cfm fan to cool the power supply), and an H403-B ac input box.

The mounting box is available for both 120 V and 240 V systems. Because a choice of front panels is provided, you can select any of the following BA11-S models.

Model	Primary Power/Front Panel
BA11-SA	120 V/control panel
BA11-SB	240 V/control panel
BA11-SC	120 V/blank panel
BA11-SD	240 V/blank panel

Figure 1-3 shows the BA11-S with the logic box cover removed. The ac input box, power supply, and H9276B logic assembly (which includes the fans and the backplane) are attached to the logic box base; the bezel is attached to the power supply. The power supply assembly is hinged to the base and can be swung open to expose the internal components; with little effort, the complete assembly can be removed from the base and replaced. Extended LSI-11 bus modules are inserted in the backplane from the rear of the box through the rear access door (Figure 1-4).

When the unit is to be mounted in an equipment rack, the logic box cover is attached to the rack with mounting hardware. The logic box base slides into the rack-mounted cover. A restraint cable is attached between the H403-B ac input box and the rack frame to prevent the base from being pulled completely out of the cover by mistake.

1.2 BA11-S APPLICATIONS

The BA11-S can be used in two ways. One, it can be used as a mounting box for a PDP-11/23B system, which consists of a KDF11-B microcomputer, MSV11-P memories and other extended LSI-11 bus options that are compatible with the PDP-11/23B system using the extended LSI-11 bus.

Two, it can be used as an expander box for the KDF11-B system. The number of expansion boxes might include as many as three mounting boxes including the box holding the CPU module.

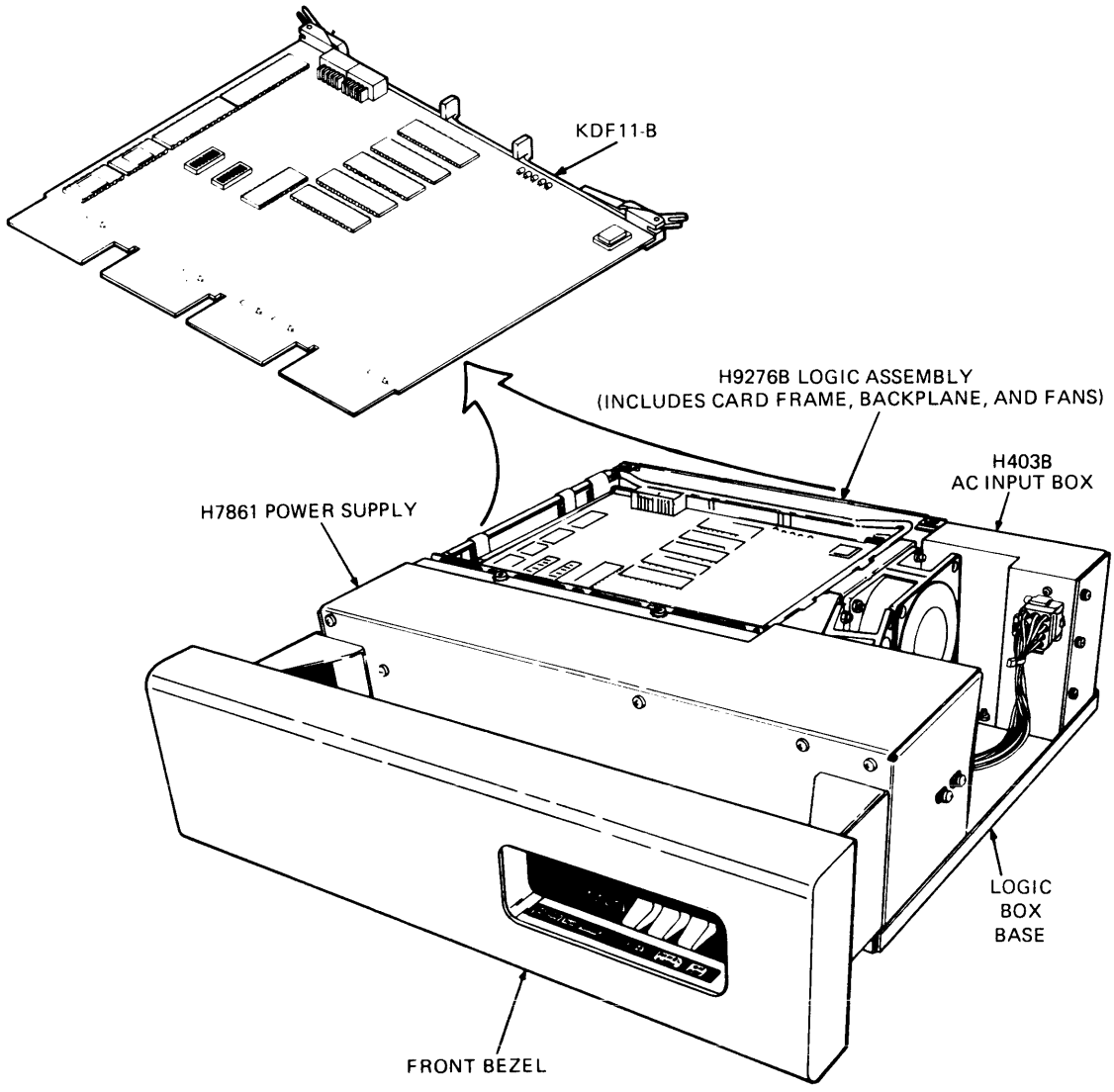

MR 6535

Figure 1-3 BA11-S Logic Box, Cover Removed

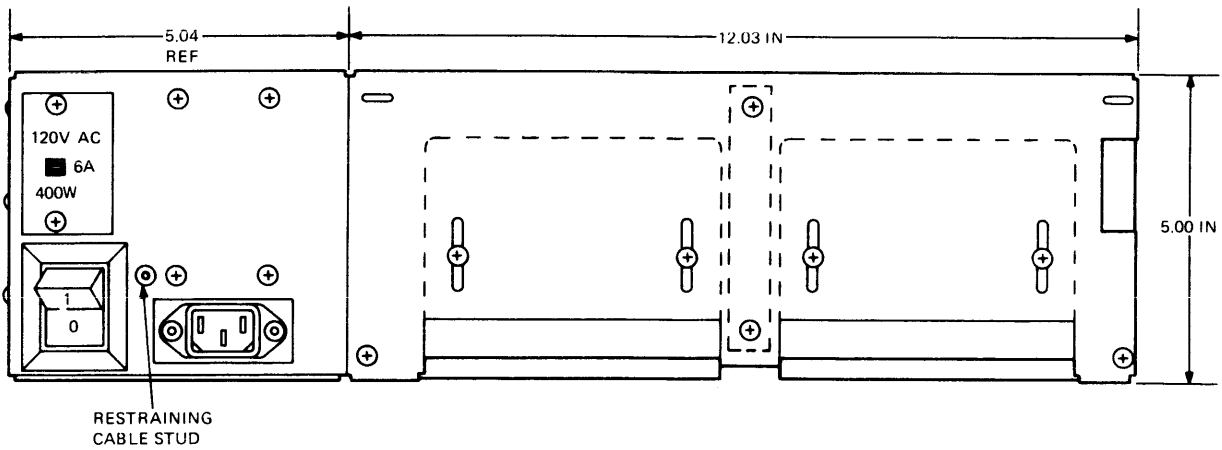

MR 6536

Figure 1-4 BA11-S, Rear View

Figures 1-5 and 1-6 show the possible combinations and includes interconnecting cable names. See that an LSI-11 system can include as many as three 9×4 backplanes (i.e., one in the main box, which holds the CPU, and one in each expansion box). Each expander box in the PDP-11/23's BA11-S system is physically identical to the main box, with the possible exception of the front panel (usually only one box has a functional front panel). The BA11-N box (with an H9273 backplane) functionally differs only slightly from that of the BA11-S box (with an H9276 backplane). The BA11-S box holds four more address lines than the BA11-N box, which are necessary for extended LSI-11 bus operation. Table 1-1 lists the CD bus modules that can be used in the H9276 backplane.

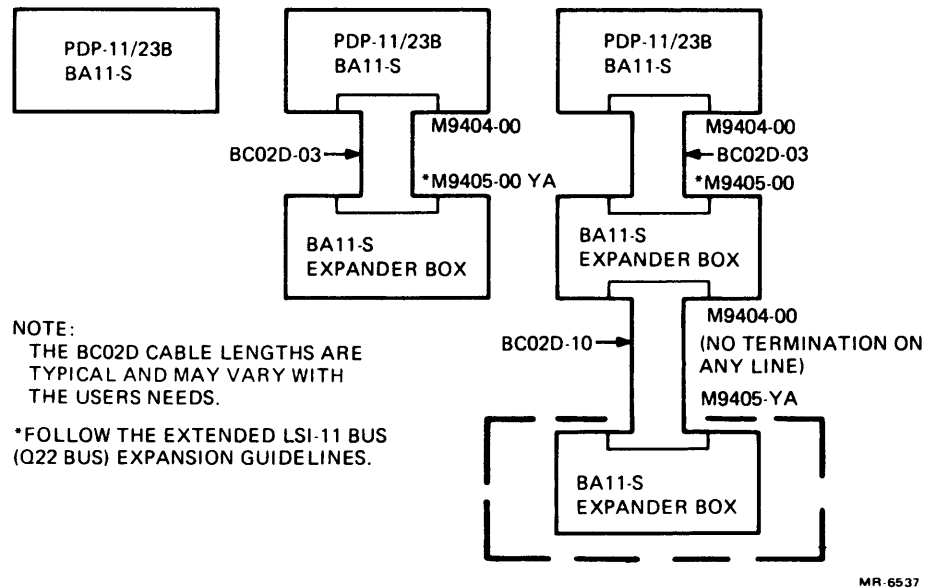

MR-6537

Figure 1-5 BA11-S Typical System Application (PDP-11/23B)

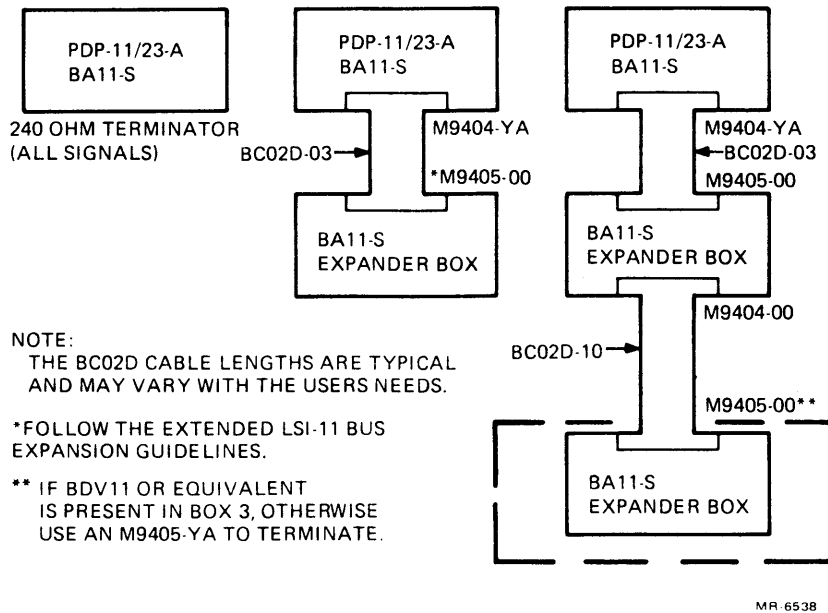

Figure 1-6 BA11-S System Application (PDP-11/23A)

Table 1-1 PDP-11/23B Fully Compatible H9276 Backplane Options

Option	Module No.	Description
CMV11	M7181	Bus control for CMR remote I/O control
*DLV11	M7940	Asynchronous serial line unit
*DLV11-E	M8017	Asynchronous serial line unit
*DLV11-F	M8028	Asynchronous serial line unit
DMV11-AA	M8053	Synchronous serial line unit (RS232/423)
DMV11-AC	M8064	Synchronous serial line unit (remote)
DPV11	M8020	Synchronous serial line unit
DRV11	M7941	Parallel line unit
DRV11-J	M8049	Parallel line unit
DUV11	M7951	Synchronous serial line unit
DZV11	M7959	Multiplexer 4-line serial line unit
FPF11	M8188	High-speed floating-point option
IBV11-A	M7954	Instrument bus interface
KDF11-B	M8189	PDP-11/23B CPU module
KEF11-A	57-00001	Hybrid floating-point option
KEF11-B	57-00006	Hybrid commercial instruction set
KPV11-A	M8016	Power fail/LTC module
KTF11-A	21-15542	Memory management unit (IC)
LAV11	M7949	LA180 printer interface
LPV11	M8027	LA180/LP05/LP25 line printer interface
MCV11-DA	M8631-AA	8Kb CMOS R/W memory w/battery
MCV11-DC	M8631-CA	32Kb CMOS R/W memory w/battery
MSV11-LF	M8059-FA	128Kb MOS R/W memory w/parity
MSV11-LK	M8059-KA	256Kb MOS R/W memory w/parity
MSV11-PK	M8067-KA	256Kb MOS R/W memory w/parity
MSV11-PL	M8067-LA	512Kb MOS R/W memory w/parity
RLV12	M8061	RL01/02 disk controller
RXV11	M7946	RX01 floppy disk controller
-	M9404	Bus cable connector
-	M9405	Bus cable connector
-	M9404-YA	Bus cable connector w/240 ohm terminator
-	M9405-YA	Bus cable connector w/120 ohm terminator

Table 1-1 PDP-11/23B Fully Compatible H9276 Backplane Options (Cont)

Option	Module No.	Description
The following modules are also fully compatible provided the proper revision is used as indicated:		
*BDV11	M8012	Bootstrap/terminator (CS rev. E or later)
*DLV11-J	M8043	4 serial line units (CS rev. E or later)
KDF11-A	M8186	PDP-11/23A CPU module (Etch rev. C or later)

*These options perform similar functions as the KDF11-B CPU module (2 serial line units, bootstrap/diagnostic read-only memory and program-controlled line clock). If any of these options are installed on a PDP-11/23B system, you must ensure that the system is properly configured, such that there are no conflicts. Serial line options, such as the DLV11-?, DZV11, and MXV11, can be configured at addresses which do not conflict with the KDF11-B. Read-only memory and line time clock options (MRV11-X, MXV11, KPV11, and BDV11) may require you to disable some duplicate function, either on the option or on the CPU module.

1.3 H9276 BACKPLANE

The connector labeled "connector 1" in Figure 1-7 has two connector slots wired in parallel (etch connections). When the KDF11-B CPU module is inserted into rows A, B, C, and D of slot 1, rows A and B carry the extended LSI-11 bus signals (alternatively, the bus signals cannot be continued from a previous backplane as previous backplanes do not have 22-bit addressing). Therefore, the A and B rows are called the extended LSI-11 bus rows.

The connector labeled "connector 2" in Figure 1-7 carries the CD bus signals. These connectors are not wired in parallel except the +5 V and ground. These connectors have no connections to the extended LSI-11 bus in rows A and B. The C and D row pins in each slot are connected to the C and D row pins in every other slot. Therefore, the pins in row C slot 1 are also connected to slot 2, 3, 4, 5, etc. (Refer to Paragraph 3.2.3 in the *PDP-11/23B Mounting Box Technical Manual* for a detailed description of the backplane wiring). If you put a module in the C and D rows slots 3, 4, and 5 and if the fingers on the module connectors are jumpered correctly, a 3-slot bus is formed. Buses of different lengths can be formed by correctly wiring the modules that make up a module set; therefore, rows C and D are called the CD bus rows.

The H9276 backplane was designed for use in the BA11-S mounting box to support dual- and quad-height extended LSI-11 bus structure, henceforth referred to as the extended LSI-11 bus. The extended LSI-11 bus is actually an 18-bit LSI-11 address bus, modified for 22-bit bus addressing.

The connectors that make up this backplane are identical to those used on the H9273 backplane. Four rows (i.e., A, B, C, and D) each have 9 slots. Each slot has two rows of connector pins, 18 on either side of the slot.

NOTE

RLV12 modules occupy the last (lowest priority) usable backplane slot.

The extended LSI-11 bus signals are found on all 9 slots of rows A and B and use rows CD connector slots for communications between any number of consecutive slots between slots 2 and 9.

Figure 1-8 shows a typical configuration comparison between the KDF11-A and KDF11-B systems. LSI-11 double-height modules are inserted into the extended LSI-11 bus slot, rows A and B on the H9276 backplane. (If one or more of the modules' options are quad modules, one or more of the CD bus option modules would have to be moved.) Paragraph 3.1.3 in the *PDP-11/23B Mounting Box Technical Manual* describes the H9276 backplane in detail and provides additional CD bus information.

NOTE

The MMV11 module is not compatible for use on the H9276 backplane.

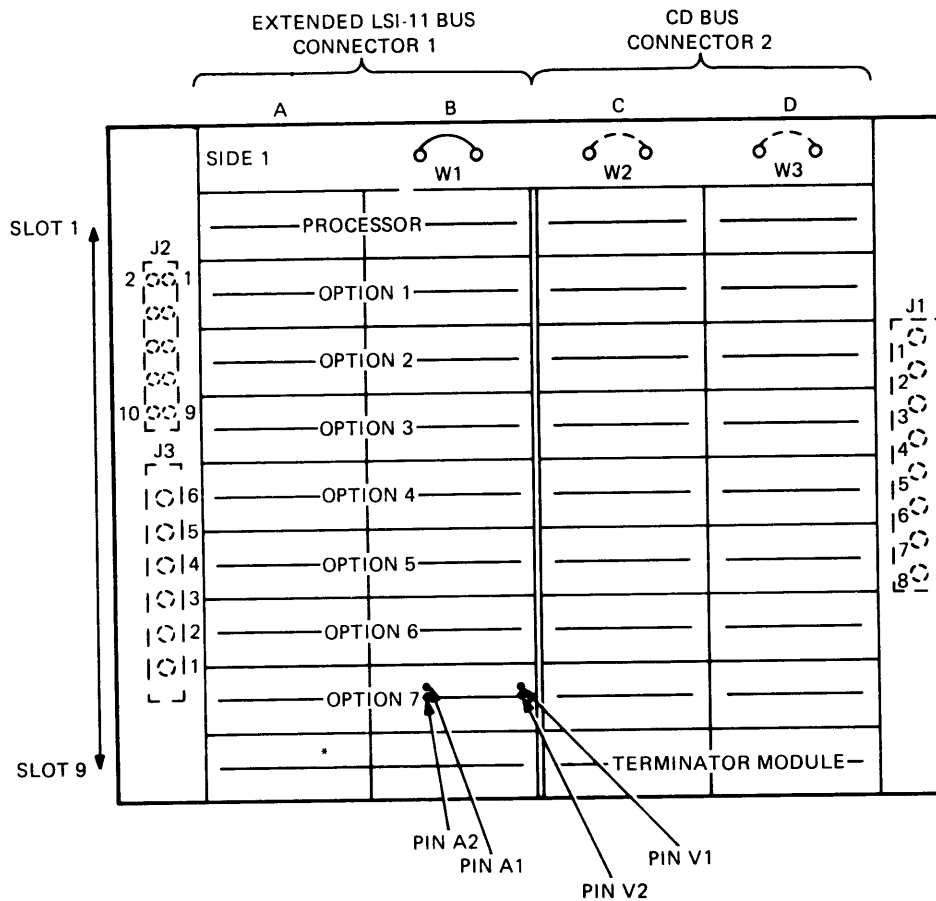

* KDF11-A SYSTEMS ONLY
 BDV11-A BOOTSTRAP/TERMINATOR
 QUAD MODULE MUST BE USED
 IN THE LAST USABLE BACKPLANE
 SLOT.

MR-6539

Figure 1-7 H9276 Backplane Connectors (Module Side)

1.4 MODULE LOADING OF THE EXTENDED LSI-11 BUS

When organizing a system, you must give specific attention to three characteristics of each module, namely, bus ac loading, bus dc loading and power used. Bus ac loading refers to the dynamic impedance that an element displays to an extended LSI-11 bus signal line. This impedance, which is due to etch runs, receiver input loading, and driver output loading, causes a reflection to occur when a step is placed on the signal line. This reflection manifests itself as a spike that occurs just after an asserting or negating edge. If too many elements are placed on a bus, the total impedance reaching to a specific signal line can produce a reflection of unacceptable magnitude; thus, a false logic signal that might cause a failure is created. Figure 1-9 shows such a false logic signal, where threshold level of an 8640 bus receiver is crossed twice because of the lumped-load reflection.

Bus ac loading is described in terms of ac loads, an ac load being defined as 9.35 pF (typical) capacitance. The ac load rating of a bus element is based on the largest of the capacitances that the element sends to the BDOOUT, BDIN, BSYNC, BREF, and BSACK signal lines. For example, if the element sends two ac loads (approximately 37.4 pF) to the BSYNC line, the element is rated at four ac loads.

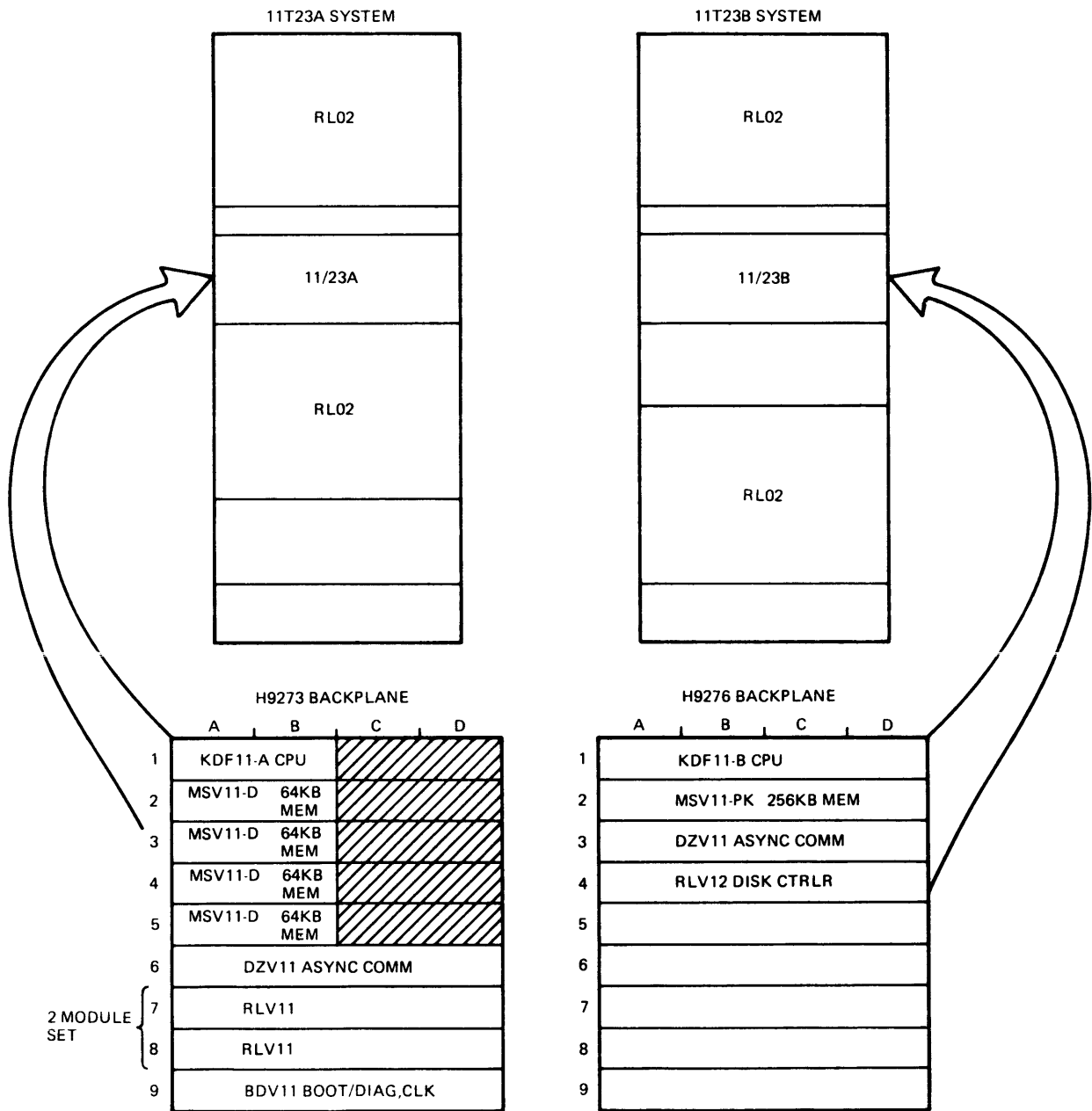

MR-6695

Figure 1-8 KDF11-A and KDF11-B Configuration Comparison

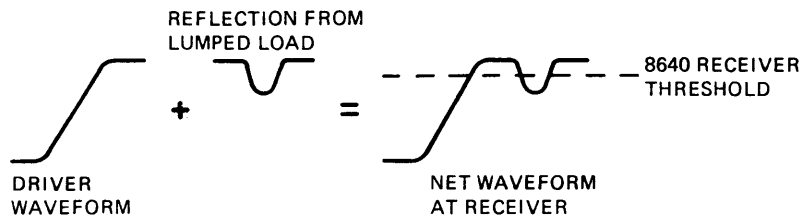

MR 6541

Figure 1-9 AC Loading Violation

In a single-backplane system, the bus can support 20 ac loads with the termination that is available on the processor module. If the other end of the bus is terminated with 120 ohm, the number of ac loads can be increased to 35. Keep in mind that this applies only to the system with one backplane; if the bus is extended off this backplane in any way, a multiple-backplane system results and the rules change. Incidentally, the backplane itself loads down the bus; therefore, the ac loads attributable to the backplane must be added when determining the total ac load.

Bus dc loading refers to the dc leakage current that an element presents to an extended LSI-11 bus signal line when that line is high (undriven). If too many elements are placed on the bus, the inactive (undriven) voltage may be lowered to such a level that bus receivers become susceptible to reflections from lumped loads. Furthermore, the overall noise margin on the high end (bus undriven) may become too small.

Bus dc loading is described in terms of dc loads, a dc load being defined as 105 μA (nominal) of leakage current (105 μA is the total of 80 μA of receiver leakage current and 25 μA of driver leakage current). The dc load rating of a bus element is **not** based strictly on the signal line that has the most leakage (e.g., dc leakage is less important on BDAL lines than on the BSYNC line); therefore, the dc load for an element should always be obtained from the specification for that element.

In both single- and multiple-backplane systems, the maximum number of dc loads allowed is 20 (backplanes have zero dc loads). Loading for customer-designed modules will have to be determined by computation of receiver and driver leakage currents.

Power consumption refers to the amount of current that must be provided by the power supply combined with each backplane. The total current to be drawn from the +5 V source must be determined individually from that to be drawn from the +12 V source. Naturally, each total must be less than the maximum rated output current for that source. To allow for typical amounts of current that might be drawn by single modules, remember this rule of thumb: keep the amount of current to be drawn from a power supply to 70 percent or less of the supply's maximum rated current.

1.5 PDP-11/23B MOUNTING BOX SPECIFICATIONS

Table 1-1 is a list of modules which are fully compatible with the PDP-11/23B system components (KDF11-B, MSV11-P, and BA11-S). Where no module or option variant is specified, assume that the all variants are implied. Table 1-2 lists significant PDP-11/23B mounting box specifications.

Table 1-2 BA11-S Mounting Box Specifications

Item	Specifications
Dimensions (including bezel)	
Width	48.3 cm (19 in)
Height	13.2 cm (5.19 in)
Depth (without mounting brackets)	57.8 cm (22.75 in)
Weight (without modules)	20 kg (44 lb)
Operating Temperature*	5° C–50° C (41° F–122° F)
Operating Humidity	10%–95% with a maximum wet bulb temperature of 32° C (90° F) and a minimum dew point of 2° C (36° F)
Input Voltage	120 Vac (BA11-SA/-SC) 240 Vac (BA11-SB/-SD)
Input Current	6 A max (BA11-SA/-SC) 3 A max (BA11-SB/-SD)
Output Voltage	+5 V @ 2 A to 36 A +12 V @ 0.0 A to 5 A

*The maximum allowable operating temperature is based on operation at sea level, i.e., at 760 mm Hg (29.92 in Hg). Maximum allowable operating temperature will be lowered by a factor of 1.8° C/100 m (1° F/100 ft) for operation at higher altitude sites.

When the equipment is being operated at the maximum allowable temperature, air flow must maintain air temperature rise to a maximum of 7° C (44.5° F).

H7861 Power Supply

The H7861 power supply is designed to meet the needs of the KDF11-B (H8189) CPU module and MSV11-P (M8067) memory module with single voltage 64K RAM (512Kb on each module). The H7861 power supply uses a unidirectional transformer in a halfwave transformer mode and provides a single-ended, switch type, regulated ac/dc converter circuit. (See Table 1-3 for H7861 power supply specifications.)

The H7861 power supply is powered directly (via a power control unit) from 120/240 Vac single-phase utility power and needs only a line cord and power control unit (H403-B). A main power board and two daughter boards (power monitor board and control circuit board) are mounted in a sheet metal enclosure to protect against voltage hazards and provide EMI shielding.

Figure 1-10 shows power interruption ride through characteristics for the H7861 power supply used in the PDP-11/23B CPU.

Table 1-3 BA11-S/H7861 Power Supply Specification

Item	Specification
Current Rating	5.5 A @ 120 V rms 2.7 A @ 240 V rms
Inrush Current	100 A peak, for 1/2 cycle at 128 V rms or 256 V rms
Apparent Power	630 VA
Power Factor	The ratio of input power to apparent power shall be greater than 0.6 at full load and low input voltage.
Output Power	+5 Vdc, ± 150 mV, @ 36 A (A minimum of 2 A of +5 Vdc power must be drawn to ensure that the +12 Vdc supply regulates correctly is drawn.)
Power Up/Down Characteristics	+12 Vdc, @ ± 360 mV, @ 5 A
Static performance	
Power up	BDCOK H goes high: @ 75 Vac BPOK H goes high: @ 85 Vac
Power down	BPOK H goes low: @ 80 Vac BDCOK H goes low: @ 75 Vac
Power up	3 ms (min) from dc power within specification to BDCOK H asserted 70 ms (min) from BDCOK H asserted to BPOK H asserted.
Power down	4 ms (min) from ac power OFF to BPOK H negated. 4 ms (min) from BPOK H negated to BDCOK H negated. 5 μ s (min) from BDCOK H negated to dc power out of specification.

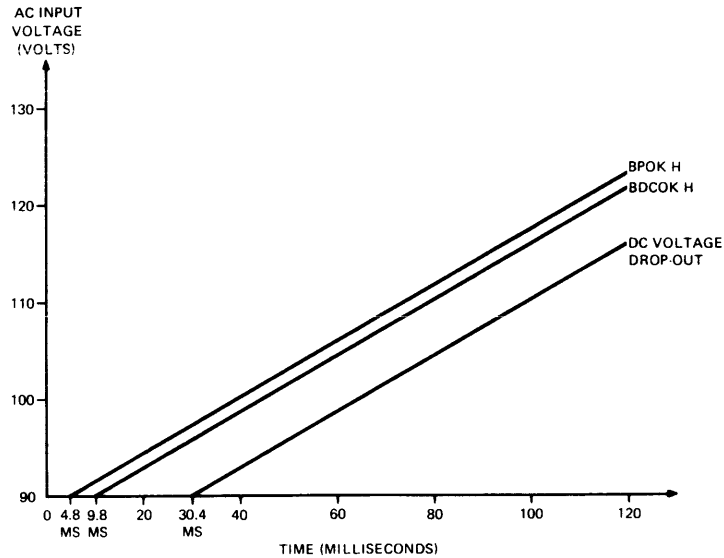

TO OBTAIN TIME FOR PARTIAL LOADING
MULTIPLY BY THE RATIO OF FULL OUTPUT
POWER TO PARTIAL OUTPUT POWER; E.G.,
 $T(1/2 \text{ LOAD}) = T(\text{FULL LOAD} \times 100\%/50\%)$.

MR 6542

Figure 1-10 H7861 Power Supply Minimum Ride-Through After Power Interruption

1.6 RELATED DOCUMENTS

The following DIGITAL documents include information for the BA11-S user.

Document	Document Number	Comments
PDP-11/23B Mounting Box Technical Manual	EK-23BMB-TM-001	In microfiche library; available in hard copy.
MSV11-P Memory User's Guide	EK-MSVIP-UG-001	In microfiche library; available in hard copy.
BDV11-AA Technical Manual	EK-BDV11-TM-001	In microfiche library; available in hard copy.
BDV11-AA User's Guide	EK-BDV11-UG-001	Not in microfiche library; available in hard copy.
KDF11-B User's Guide	EK-KDF1B-UG-001	In microfiche library; available in hard copy.

General information about educational and maintenance services provided by DIGITAL, as well as equipment warranty statements, can be found in the *Microcomputer Processor Handbook* (1979-1980).

CHAPTER 2

UNPACKING, INSTALLATION, AND OPERATION

2.1 UNPACKING

The PDP-11/23B is packaged for shipment in a protective box. Remove the PDP-11/23B system from the shipping box and visually examine the system for damage. Save the shipping containers and packing materials in case it is necessary to return the unit for service.

2.2 INSTALLATION

You can start physical installation of the system when you have unpacked and checked the shipment for completeness. You might consider, at some time, to either add to an existing system or create a new system. If so, check the appendices in the *PDP-11/23B Mounting Box Technical Manual*, which include important information about backplane and module configuration.

2.2.1 Preliminary Checks

Before installing the logic box base, check the features described in the following paragraphs.

2.2.1.1 AC Voltage Selection – The BA11-S can be used with line voltage of either 120 Vac or 240 Vac. Only the ac line cord is different for the two voltages. However, a voltage selection switch must be set to the position that agrees with the line voltage being used. This switch is found on the rear of the ac input box, above the circuit breaker (Figure 2-1). The switch lever extends through a plate that is attached to the box. The plate is made so that the screw holes in the plate and the input box line up only when the switch position agrees with the printing on the outside on the plate. If the line voltage being used is 120 Vac, the label “120 Vac” should be printed on the plate above the switch lever. If the printing on the plate is “240 Vac,” remove the plate, and flip it over. The label “120 Vac” should be there. Also, see that the switch lever itself is imprinted with “240 Vac.” Move the switch lever down; “120 Vac” should appear on the top of the lever. Replace the plate over the switch lever so that the printing on the outside of the plate reads “120 Vac.” (When the plate is on, the printing on the switch lever cannot be seen.)

2.2.1.2 Backplane Jumper Positions – There are three jumper positions – W1, W2, and W3 – on the H9276 backplane (Figure 2-2). A jumper is installed in jumper position W1 only, when the backplane is made. Table 2-1 summarizes the conditions under which jumpers should be inserted or removed.

The jumper in position W1 is used with CPU event interrupts. These interrupts can be started in two ways. First, an external (to the BA11-S) signal source can be used to pull the extended LSI-11 bus BEVNT L line low; in this arrangement, the jumper in W1 of each H9276 backplane in the system would have to be removed. Second, the LTC signal generated in the H7861 power supply can be used to pull the BEVNT L line low, thereby setting vectored interrupts at a rate that depends on the BA11-S line frequency. W1 connects the LTC signal to the BEVNT L line; so, in this instance, the jumper would be left in position W1 of the H9276 backplane. In a multiple-box system, jumper W1 is removed from all expansion boxes in the system and must be the source of the LTC signal. Therefore, the W1 jumper must be inserted in the backplane of the first box in the system and must be removed from all others.

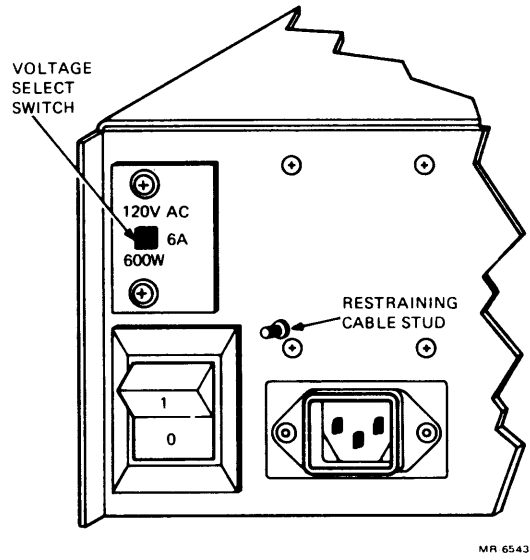

Figure 2-1 BA11-S Voltage Selection Switch

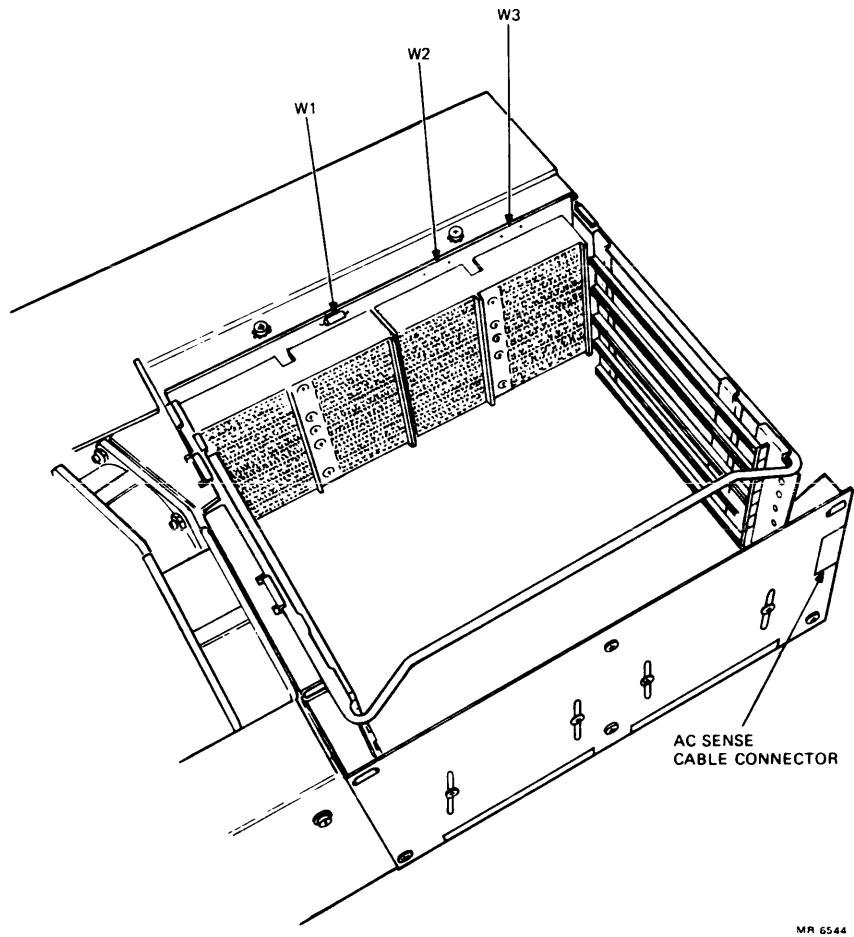

Figure 2-2 Backplane Jumpers

Table 2-1 Backplane Jumpers

Jumper	Jumper(s) In	Jumper(s) Out
W1	When the H7861 power supply-generated LTC signal is used to assert the extended LSI-11 bus BEVNT L signal (inserted for CPU box).	When it is not wanted to have line time clock (LTC) sourcing BEVNT L, such as when an external source is used instead.
W2, W3	Usually unused.	Unused.

2.2.1.3 Bezel Assembly Jumper Positions – There are four jumper positions – W1, W2, W3, and W4 – on the printed circuit board of the bezel assembly (Figure 2-3). When the board is built, jumpers are inserted in positions W1, W2, and W4; position W3 is left blank. Table 2-2 describes the conditions under which jumpers are inserted or removed.

If it is necessary to remove the bezel assembly printed circuit board for any reason, follow the instructions for removal of the bezel assembly given in Paragraph 4.3.2 of the *PDP-11/23B Mounting Box Technical Manual*.

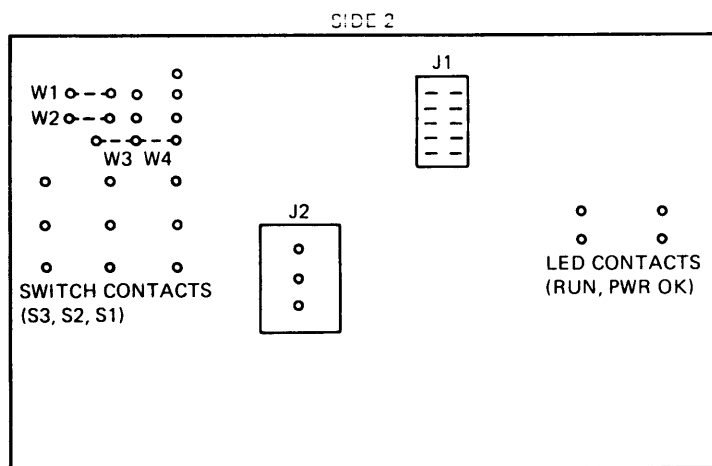

- NOTES:
1. VIEW IS FROM THE REAR OF THE BEZEL WHEN THE BOARD IS MOUNTED ON THE BEZEL.
 2. JUMPERS ARE MOUNTED ON SIDE 1.

MR 6545

Figure 2-3 Front Panel Bezel Printed Circuit Board

Table 2-2 Bezel Assembly Jumpers

Jumper	Jumper(s) In	Jumper(s) Out
W1, W2	When the bezel AUX ON/OFF switch is used to control the power supply-generated LTC signal. (When the switch is in the AUX ON position, LTC-initiated interrupts are possible.)	When the bezel AUX ON/OFF switch is used to turn the system power controller on and off (Paragraph 2.2.1.4).
W3	When the bezel is to be mounted on an expander box. (W3 permits the HALT switch to light the RUN indicator.)	When the bezel is part of the main box, i.e., the CPU is mounted in this bezel's backplane.
W4	When the bezel is part of the main box. (W4 enables the S RUN L signal to light the RUN indicator.)	When the bezel is mounted on an expander box.

2.2.1.4 Power Controller Cable Installation – In a large system, it is convenient to turn on the power to each unit from a central point, instead of turning on each unit individually. You can do this by including a power controller (such as the DIGITAL 874 model) with the system. Plug the power controller into the ac main and plug each unit into the “switched” outlets on the controller. By keeping each unit’s ON/OFF switch in the ON position, you can use the ON/OFF switch on the power controller to apply and remove power for all system units together.

Furthermore, you can configure the power controller ON/OFF switch so that power control can be switched from some other location, e.g., from the AUX ON/OFF switch on the BA11-S bezel. (Paragraph 2.2.4 describes possible power connection designs for the PDP-11/23B systems.) If you plan to include a power controller with the system and want to use the bezel AUX switch to turn system power on and off, a three-wire Mate-N-Lok™ cable is connected between J2 of the bezel assembly printed circuit board (Figure 2-3) and a notch opening in the module access door frame (Figure 2-2). You can then connect the cable to the power controller ON/OFF switch so the two switches are in parallel. By keeping the controller switch open, you can control system power application by using the AUX switch.

If the cable is not installed in the bezel assembly, plug the connector into J2 of the assembly printed circuit board. Route the cable back to the power supply and across the power supply chassis. Use two (2) strain reliefs to fasten the cable to the upper section of the power supply. Continue routing the cable down and around the notched corner of the power supply and back to the cutout in the access door bracket. Snap the connector into the bracket to complete the installation.

2.2.1.5 Module Insertion and Removal – You must turn off power before you insert and remove modules. Use the front panel AUX ON/OFF switch or the ON/OFF switch on the rear of the ac input box to turn off the power. (Refer to Paragraph 2.3 for a description of each of these switches.)

Some quad modules are equipped with metal extractor-type handles that help with module insertion and removal. When inserting such a module into the backplane, start by sliding the module, component side up, into the card guides. Slide the module all the way in and just start the module connector fingers into the backplane connectors. Fit the prongs of the handles into the holes in the card frame, as shown in Figure 2-4. Press in on both handles together to completely insert the fingers in the backplane connector.

® Mate-N-Lok is a trademark of AMP, Inc.

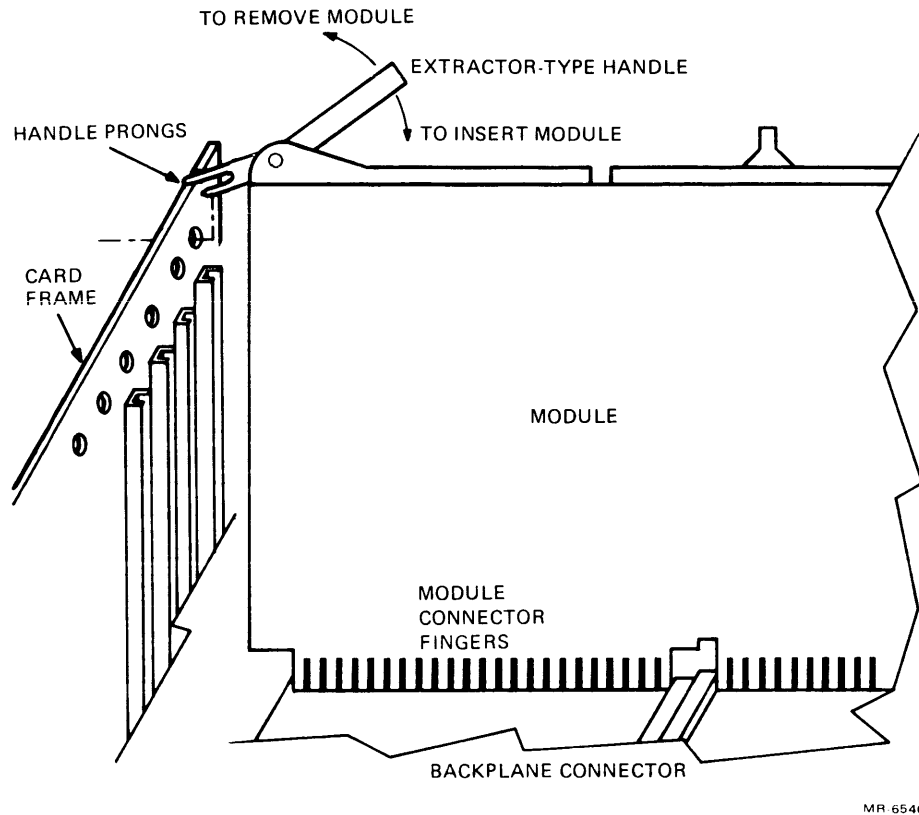

MR 6546

Figure 2-4 Insertion and Removal of Modules with Extractor-Type Handles

To remove a module, pull both handles out together until the prongs of the handle are clear of the holes in the card frame. The module fingers will now be clear of the backplane connector and you can remove the module easily.

CAUTION

Modules and/or the backplane assembly might be damaged if modules are inserted and removed with the power on, or if the modules are inserted upside down. (Refer to Paragraph 3.2.3 in the *PDP-11/23B Mounting Box Technical Manual* for details about module restraints.)

2.2.1.6 Module Installation – The equipment is shipped from the factory with the modules installed. Bus cables and communication cables must be connected to the modules, if not in place. When removing modules to connect cables or when installing new modules in a known installation, follow these rules.

1. Ensure that double-size modules are inserted correctly in the backplane; i.e., extended LSI-11 bus modules plug into rows A and B (the two left-most rows), CD bus modules plug into rows C and D, and both types must be inserted component-side up. (Refer to Paragraph 3.2.3 in the *PDP-11/23B Mounting Box Technical Manual* for details.)

2. Insert the CPU only in bus position 1 of the H9276 backplane. ("Bus positions" are defined in the backplane selector tables.)
3. Confirm that jumper W1 is in place in the backplane of the first system box; other backplanes must have the jumper removed (Paragraph 2.2.1.2).
4. If a module uses the bus grant and interrupt signals (BDMGI L/BDMGO L and BIAKI L/BIAKO L, in order), ensure that there are no empty extended LSI-11 bus positions between the module and the CPU, although empty CD bus positions are permitted (Refer to Paragraph 3.2.3 in the *PDP-11/23B Mounting Box Technical Manual*).
5. Always confirm that modules are seated firmly and securely in the backplane.
6. The +5 Vdc regulated voltage is rated at 36 A, full load, while the +12 Vdc regulated voltage is rated at 5 A, full load. When installing new modules in a system backplane, refer to Table A-1 in the *PDP-11/23B Mounting Box Technical Manual*.

2.2.2 Mounting the Logic Box Cover in an Equipment Rack

Use the following procedure to mount the logic box cover in an equipment rack. Figure 2-5 shows the mounting dimensions and shows the cover mounted to the four cabinet uprights. The item callouts in Figure 2-5 and in the following mounting procedure are identified in a unit assembly drawing (Figure 2-6). Additional installation information can be obtained from drawing D-UA-BA11-S-D. Table 2-3 is a parts list that will help you identify each part called out in Figure 2-6. The assembly drawing will make assembly removal easier, and you should refer to it when necessary.

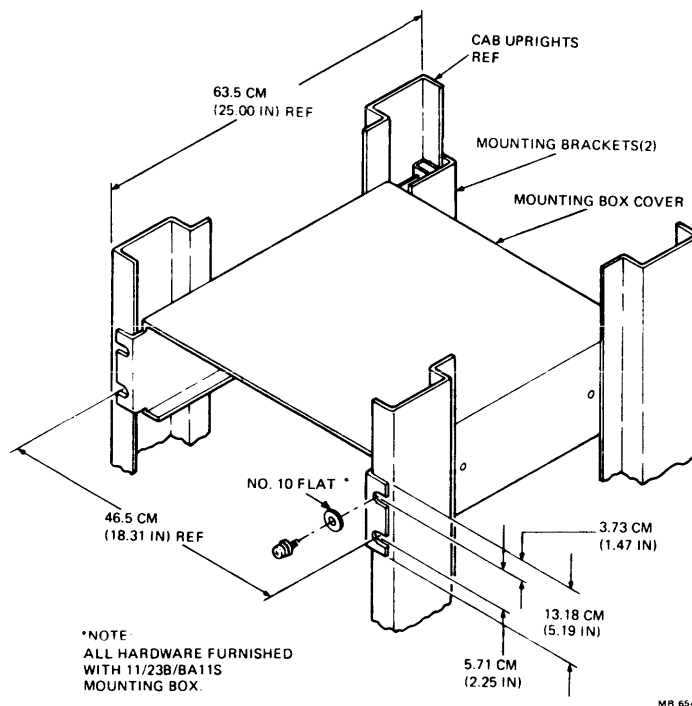
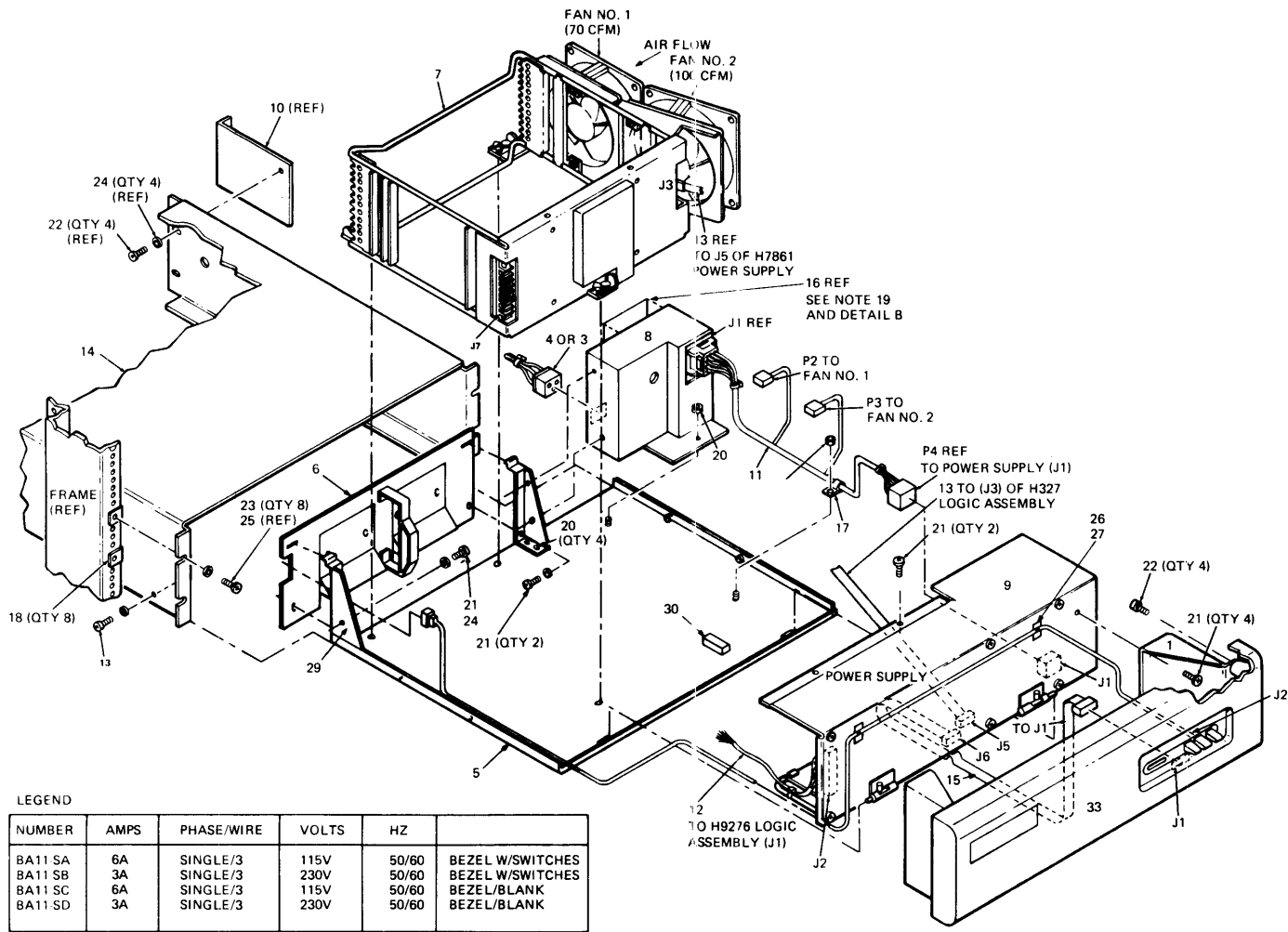

Figure 2-5 BA11-S Cover Mounting Dimensions



MR-6587

Figure 2-6 BA11-S Unit Assembly Drawing

Table 2-3 Parts List

Item No.	Part No.	Description	Quantity			
			SA	SB	SC	SD
1	74-18573-00	Brkt, bezel	2	2	2	2
2	37-00323-00	Pkg, computer 11/03-L, -N and DMP23	1	1	1	1
3	17-00083-02	Line cord (120 Vac) U.S.A.	1		1	
4	17-00090-00	Line cord (240 Vac) U.S.A.		1		1
5	70-18360-00	Base, logic box Weldment	1	1	1	1
6	70-18352-00	Door assembly	1	1	1	1
7	H9276-B	H9276-A and card wire frame	1	1	1	1
8	OH403-B	AC input box H403-B	1	1	1	1
9	H7861-00	BA11-SA, SB, P/S +5 V @ 36 A, +12 V @ 5 A	1	1	1	1
10	74-18276-00	Brkt, support (logic box)	1	1	1	1
11	70-14093-00	AC harness	1	1	1	1
12	70-17971-00	DC harness	1	1	1	1
13	70-11411-OK	3M cable (LSI-11)	1	1	1	1
14	74-18275-00	Cover, logic box	1	1	1	1
15	70-11411-1A	Console/backplane cable	1	1		
16	36-17674-00	Label, serial and power	1	1	1	1
17	90-07084-00	Clamp, cable, screw KTD 7/16	1	1	1	1
18	90-07786-00	Retainer, U-nut 10/32	8	8	8	8
19	90-08196-00	Recp, clip-on 1/4 turn fastnr	2	2	2	2
20	90-06563-00	Nut, kep 8/32	10	10	10	10
21	90-09642-00	Screw, pan, Phil 8-32 × 1/4	14	14	14	14
22	90-00049-27	Screw, pan, Phil 8-32 × 3/8	9	9	9	9
23	90-9700-00	Screw, trus, Phil 10-32 × 1/2	8	8	8	8
24	90-06661-00	Washer, flat, .437 × .187	9	9	9	9
25	90-10032-00	Fastener, push-on (.170 dia)	4	4		
26	90-07880-00	Tie, cable bundle	5	5	5	5
27	90-08264-00	Mount, cable tie adhesive back	3	3	3	3
28	74-25342-00	Bracket, door support	1	1	1	1

Table 2-3 Parts List (Cont)

Item No.	Part No.	Description	Quantity			
			SA	SB	SC	SD
29	74-25342-01	Bracket, door support opposite	1	1	1	1
30	74-25442-00	Foam, base	1	1	1	1
31	70-18384-03	Sense cable, box	1	1	1	1
32	70-18386-00	Console assembly	1	1	1	1
33	74-15313-02	Die cast blank No. 8-32			1	1
34	74-15313-03	Die cast window, logo	1	1		

1. When the unit is shipped, the logic box cover is held to the base by four screws (these are used only in nonrack-mounted applications) and a single shipping screw, which, for safety, must be in place whenever the unit is moved or shipped. First, remove the four shipping screws that attach the cover to the base; then, open the rear door and remove the restraining screw.
2. Attach the Tinnerman nuts to the cabinet uprights in eight places.
3. Mount the cover to the front cabinet uprights using four 10-32 screws and four No. 10 flat washers.
4. Attach the two support brackets to the cover using four 8-32 Phillips screws.
5. Attach the support brackets to the rear cabinet uprights using four 10-32 Phillips screws and four No. 10 flat washers.
6. Slide the unit into the cover. In the rear of the unit, attach a restraining cable to the stud on the H403-B ac input box with a No. 8 nut. Anchor the other end of the restraining cable to the chassis or patch panel.
7. If you must move or ship the system, replace the shipping screw.
8. A safety restraining cable is located on the right rear side of the unit (when looking from the front). This cable (DEC Part No. 12-15700-06), when attached to the rear of the ac input box, keeps the logic box base from being overextended. When the system unit is in the closed position, the restraining cable loops around at the rear of the unit inside the cover. When the base is pulled out from the cover to its extended position, the 44 cm (17-1/2 inch) restraining cable holds the box, preventing the base from accidentally being pulled completely out of the cover.

To pull the base completely out of the cover, remove the nut on the H403-B ac input box stud, and then remove the restraining cable. Slide the base forward and set the base out of the way.

2.2.3 Installing the Logic Box Base in the Cover

Set the rear of the logic box base on the support flanges of the cover and slide the base in until the base is in the closed position. Take care not to pinch the cables while sliding the base in.

NOTE

A stud extending from the H403-B ac input box is used to anchor a restraining cable (DEC Part No. 12-15700-06) to the patch panel, therefore preventing the logic box base from accidentally being pulled completely away from the cover assembly.

Perform the following steps to complete the installation.

NOTE

The box being installed is either the main box, i.e., the one holding the CPU, or an expander base (two expander boxes can be added). Modify the following instructions to satisfy the type of box you are installing; e.g., if there is a blank front panel, skip the first half of step 1.

1. Put the AUX switch on the front panel in the OFF position; put the ON/OFF switch on the ac input box in the OFF position.
2. When the AUX switch on the front panel is in the ON position, the two wires of the power controller cable are common (Paragraph 2.2.1.4). Connect the loose end of the cable to the input circuit of the power controller so that the AUX switch controls the application of primary power to the controller. Keep the AUX switch in the OFF position.
3. To install the expanded LSI-11 bus expansion cable assemblies, open and remove the rear access door by turning the two quarter-turn screws in the lower corners of the door, then swinging the door out and up to unhook it. Then, put it aside. The BC02D cable and module configurations are listed in Table 2-4. When inserting the modules, make sure the connectors are on top.

Table 2-4 Extended LSI-11 Bus Expansion Cable Assemblies (PDP-11/23B)

Assembly	Assembly Arrangement	Insert Modules In
BC02D	Two BC02D-03 cables One M9404-00 module	Rows A and B of the first open slot after all other extended LSI-11 bus options have been installed in the main box.
	One M9405-00 module	Rows A and B of slot 1 of expander box 1.
BC02D	Two BC02D-10 cables One M9404-00 module	Rows A and B of the first open slot after all other Q22 bus options have been installed in expander box 1.
	One M9405-YA module	Rows A and B of slot 1 of expander box. 2.

4. After installing the correct module and cable, leave the cable extending out of the rear opening, and replace the access door in the reverse of the way it was removed. Loosen the two Phillips screws on the correct cable strain relief to allow enough space for the cable to exit without binding when the box is extended. After installing the cables, retighten the two screws.

NOTE

“XX” in the cable assembly number means the length, which can be 2, 3, 4, 6 or 10 ft (each cable of an assembly is the same length). When both assemblies are used in a system (three boxes), the lengths differ by 214 cm (7 ft). To assist in servicing, the BC02D cables for the first expansion box should be 92 cm (3 ft) long, while the cables for a second expansion box should be 305 cm (10 ft) long.

2.2.4 Power Connections

The separate mounting boxes of a multiple-box system can be connected to a power source in different ways. Figure 2-7 shows how you might connect the boxes in typical PDP-11/23B systems using only BA11-S mounting boxes. Figure 2-7 shows power connections to a controller; however, the controller is turned on and off from different locations. That is, in Figure 2-7, the switch that turns the power ON and OFF is found on the power controller, or from some place external to the controller AUX ON/OFF switch or on the PDP-11/23B front panel. In Figure 2-7 the switch that turns power ON and OFF is the AUX ON/OFF switch on the PDP-11/23B front panel. If you buy the BA11-S with a front panel, you will be able to control the complete system power as shown in Figure 2-7.

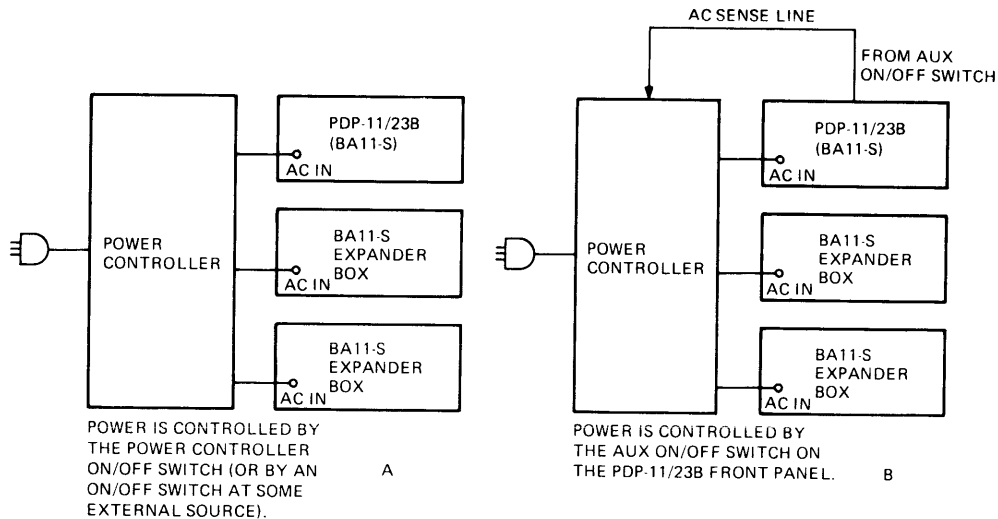

MR 654R

Figure 2-7 Power Connections, PDP-11/23B

2.2.5 Installation Checks

When you have completed the installation, check the operating condition of the equipment. This is a relatively easy task if the system is a PDP-11/23B. This system includes a pair of 2K ROMs that have BDV11 bootstrap-type diagnostic programs. When the PDP-11/23B system power is turned on, or when the system is restarted, diagnostic programs implemented by the on-board ROMs are automatically started and executed. These diagnostics verify the operation of a number of options that you might have in your system. Four red lights, found on the KDF11-B module, indicate the quick-test results (17 octal error types) after a power-up/reboot failure.

NOTES

1. Options that are not checked by the diagnostic boot-ROMs have separate diagnostic programs available.
2. When problems are found with system options, refer to the appropriate option technical manual for instructions. For those problems that are isolated to the PDP-11/23B itself, refer to Chapter 4 of the *PDP-11/23B Mounting Box Technical Manual* which includes some troubleshooting hints and procedures.

2.3 OPERATION

The BA11-S can have either a blank front panel or one equipped with three switches and three indicators. The control-equipped front panel is shown in Figure 2-8 (one indicator is not used). Table 2-5 lists the switches and indicators and describes the function of each. Refer to Paragraph 3.2.4 in the *PDP-11/23B Mounting Box Technical Manual* for details.

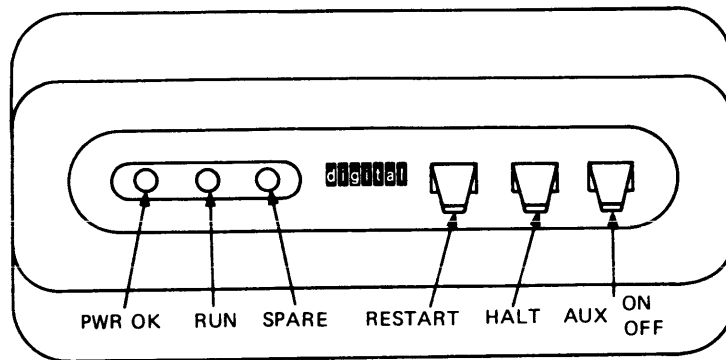

MR-6549

Figure 2-8 Front Panel Switches and Indicators

In addition to the front panel switches and indicators, there is an ON/OFF switch and a primary voltage selection switch, both on the ac input box. The ON/OFF switch stays in the ON position when a power controller is used to apply primary power to the BA11-S. If a power controller is not used, the switch can be used to turn power ON and OFF. Refer to Paragraph 2.2.1.1 for information about the primary voltage selection switch.

Table 2-5 BA11-S Front Panel Switches and Indicators

Description	Function
Switches	
AUX ON/OFF	<p>Can be used for any needed function (switch is rated at 48 Vdc, 1 A). Two specific functions are:</p> <p>If the BA11-S is wired to control system power, the AUX switch turns the power on and off. If the BA11-S is not wired to control system power, the switch can control the LTC signal, disabling the signal when the switch is in the OFF position.</p>
HALT	<p>In the down position, the HALT switch forces the CPU to suspend usual program execution, enables console ODT microcode operation, and permits single-instruction execution. To continue program execution, return the HALT switch to the up position and enter a P command from the console terminal (providing the contents of register R7 were not changed; refer to Chapter 4 of the 1979–1980 <i>Microcomputer Processor Handbook</i> for a description of console ODT command use).</p> <p>In an expander box, the HALT switch can be used to light the RUN indicator. (Refer to Paragraph 3.2.4 of the <i>PDP-11/23B Mounting Box Technical Manual</i>.)</p>
RESTART	<p>When the user presses the momentary RESTART switch, the CPU automatically carries out a power-up sequence; then, the user can reboot the CPU at any time from the front panel.</p>
Indicators	
PWR OK	<p>The PWR OK indicator lights when the power supply dc voltages are present.</p>
RUN	<p>The RUN indicator lights when the CPU is executing programs.</p>

Reader's Comments

PDP-11/23B Mounting Box User's Guide
EK-23BMB-UG-001

Your comments and suggestions will help us in our continuous effort to improve the quality and usefulness of our publications.

What is your general reaction to this manual? In your judgment is it complete, accurate, well organized, well written, etc.? Is it easy to use? _____

What features are most useful? _____

What faults or errors have you found in the manual? _____

Does this manual satisfy the need you think it was intended to satisfy? _____

Does it satisfy *your* needs? _____ Why? _____

Please send me the current copy of the *Technical Documentation Catalog*, which contains information on the remainder of DIGITAL's technical documentation.

Name _____ Street _____

Title _____ City _____

Company _____ State/Country _____

Department _____ Zip _____

Additional copies of this document are available from:

Digital Equipment Corporation
444 Whitney Street
Northboro, MA 01532
Attention: Printing and Circulating Service (NR2/M15)
Customer Services Section

Order No. EK-23BMB-UG



Do Not Tear – Fold Here and Staple

digital



No Postage
Necessary
if Mailed in the
United States

BUSINESS REPLY MAIL
FIRST CLASS PERMIT NO. 33 MAYNARD, MA.

POSTAGE WILL BE PAID BY ADDRESSEE

**Digital Equipment Corporation
Educational Services Development and Publishing
200 Forest Street (MR1-2/T17)
Marlboro, MA 01752**

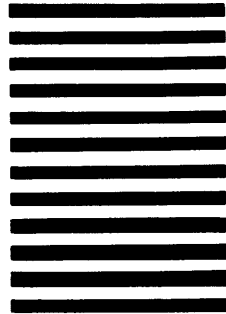

Digital Equipment Corporation • Bedford, MA 01730