

PDP-11/23-PLUS

SYSTEM MANUAL



PDP-11/23-PLUS

SYSTEM MANUAL

1st Edition, January 1982

Copyright © 1982 by Digital Equipment Corporation
All Rights Reserved

The material in this manual is for informational purposes and is subject to change without notice.

Digital Equipment Corporation assumes no responsibility for any errors which may appear in this manual.

Printed in U.S.A.

The manuscript for this book was created on a DIGITAL Word Processing System and, via a translation program, was automatically typeset on DIGITAL's DECset-8000 Typesetting System. Book production was done by Educational Services Development and Publishing in Marlboro, MA.

The following are trademarks of Digital Equipment Corporation:

| | | |
|---|-----------|---------|
| DEC | EduSystem | RSFS |
| DECnet | IAS | RSX |
| DECUS | MASSBUS | TOPS-10 |
| DECsystem-10 | MINC-11 | TOPS-20 |
| DECSYSTEM-20 | OMNIBUS | UNIBUS |
| DECwriter | OS/8 | VAX |
| DIBOL | PDP | VMS |
|  | PDT | VT |

CONTENTS

PREFACE

CHAPTER 1 GETTING STARTED

| | |
|--|---|
| INTRODUCTION | 1 |
| CONTROL PANEL | 2 |
| SYSTEM CONFIGURATION | 2 |
| RL02 Disk Drives | 2 |
| BREAK Key | 4 |
| Receive Speed / Transmit Speed | 5 |
| Bootstrap Technique | 5 |
| DISK CARTRIDGE LOADING PROCEDURE | 5 |
| INITIAL SYSTEM START-UP | 7 |
| LOADING THE OPERATING SYSTEM..... | 7 |
| CHANGING A DISK CARTRIDGE | 8 |
| POWERING DOWN | 9 |

CHAPTER 2 PROGRAMMING

| | |
|--|----|
| INTRODUCTION | 11 |
| DIAGNOSTIC PROGRAMS | 11 |
| The DLDP + Diagnostic Programs | 12 |
| How to Find a Diagnostic Program | 12 |
| Help Messages | 14 |
| Diagnostic Chain Files | 14 |
| Running Individual Diagnostic Programs | 14 |
| How to Copy the Diagnostic Disk | 15 |
| DEC / X11 | 17 |
| RSX-11M SOFTWARE | 18 |
| Monitor Functions | 19 |
| Multiprogramming | 19 |
| Event-Driven Priority Scheduling | 19 |
| Task Checkpointing | 19 |
| Dynamic Memory Allocation | 19 |
| Executive | 19 |
| I/O Services | 20 |
| File System | 20 |
| User Interface | 20 |

| | |
|--|----|
| RSTS/E AND CTS-500 SOFTWARE | 20 |
| Timesharing | 21 |
| Dynamic Allocation of System Resources | 21 |
| Privilege | 22 |
| Batch Processing | 22 |
| File System | 22 |
| Terminal Handling | 23 |
| Shared Common Code | 24 |
| Disk Data Cache | 24 |
| Intertask Communication | 24 |
| Disk File and Device Backup | 24 |
| System Operation Control | 25 |
| System Reliability and Maintenance | 25 |
| User Command Languages | 26 |
| DIGITAL Command Language (DCL) | 26 |
| Concise Command Language | 26 |
| | |
| CHAPTER 3 INSTALLATION CHECKOUT AND TROUBLESHOOTING | |
| | |
| INTRODUCTION | 27 |
| UNPACKING PROCEDURE | 27 |
| INSTALLATION CHECKOUT PROCEDURE | 29 |
| TROUBLESHOOTING | 36 |
| Using the Flowchart..... | 39 |
| BOOTSTRAP DIALOG RESPONSE | 39 |
| AC Power Indications | 40 |
| 874 Power Controller..... | 40 |
| Terminal Off Line Checks | 40 |
| Terminal Power Cable Connection..... | 40 |
| Computer Switches and Indicators..... | 40 |
| PWR OK Indicator..... | 41 |
| Check Power Switches and Power Cable | 41 |
| RUN Indicator ON | 41 |
| Terminal Interface Cabling | 41 |
| NO PROMPT AFTER BOOTSTRAP | 42 |
| Disk Drive Power Indications | 42 |
| Check Disk Cable Connections | 42 |
| Check Disk Cartridge | 43 |
| | |
| CHAPTER 4 ADVANCED HARDWARE CHECKOUT | |
| | |
| INTRODUCTION | 45 |
| BOOTSTRAP AND DIAGNOSTIC PROGRAMS | 45 |
| Diagnostic Errors..... | 46 |
| Serial Line Unit Error..... | 49 |
| CPU, Memory, or ROM Error | 49 |
| Disk Bootstrap Errors..... | 49 |
| Trap Vector..... | 51 |
| ON-LINE DEBUGGING TECHNIQUE (ODT) | 51 |

| | |
|---|----|
| TROUBLESHOOTING WITH DLDP + | 52 |
| Error Messages | 52 |
| Restarting Programs | 52 |
| Modifying a Diagnostic Program | 52 |
| Single Instruction Execution | 54 |
| Expanding the Diagnostic Chain | 54 |
| TROUBLESHOOTING WITH DEC/X11 | 56 |
| Error Messages | 56 |
| The System Error Printout | 56 |
| The Data Error Printout | 57 |
| The Status Error Printout | 57 |
| Selecting and Deselecting Program Modules | 58 |
| Expanding the Run-Time Exerciser | 59 |
| | |
| CHAPTER 5 SYSTEM COMPONENTS | |
| | |
| INTRODUCTION | 61 |
| PDP-11/23-PLUS MODELS | 61 |
| PDP-11/23B PROCESSOR SUBSYSTEM | 61 |
| KDF11-B Microprocessor | 64 |
| MSV11-P Memory | 68 |
| DZY11 Asynchronous Multiplexer | 70 |
| RLV12 Disk Controller | 70 |
| BA11-S Mounting Box | 73 |
| H9276 Backplane | 73 |
| H7861 Power Supply | 73 |
| H403-B AC Input Box | 73 |
| Control Panel | 76 |
| H349 DISTRIBUTION PANEL | 76 |
| RLQ2 DISK SYSTEM | 78 |
| H9642 CONSOLE CABINET | 79 |
| 874 POWER CONTROLLER | 79 |
| | |
| CHAPTER 6 OPTIONAL SYSTEM COMPONENTS | |
| | |
| INTRODUCTION | 81 |
| TERMINAL OPTIONS | 82 |
| VT100 and VT102 Terminals | 82 |
| Summary of VT100 and VT102 Specifications | 83 |
| LA120 DECwriter III | 83 |
| BA11-S EXPANDER BOX | 85 |
| | |
| CHAPTER 7 SYSTEM REQUIREMENTS | |
| | |
| INTRODUCTION | 87 |
| SYSTEM POWER | 87 |
| ENVIRONMENT | 88 |
| Heat Dissipation | 89 |
| Radiated Emissions | 89 |
| Cleanliness | 89 |
| Cooling | 90 |

| | |
|------------------------------|----|
| Static Electricity | 90 |
| Disk Cartridge Storage | 90 |

CHAPTER 8 RULES FOR EXPANSION

| | |
|---|-----|
| INTRODUCTION | 91 |
| PRIORITY CHAINING | 91 |
| MULTIPLE BACKPLANE CONFIGURATION RULES | 91 |
| MICROPROCESSOR RECONFIGURATION | 94 |
| CPU Option..... | 94 |
| Device Selection | 96 |
| Boot/Diagnostic ROM | 97 |
| Serial Line Units (SLU)..... | 99 |
| SLU Baud Rate Selection..... | 99 |
| Character Formats | 99 |
| Break Halt | 101 |
| Internal/External SLU Clock Jumpers | 101 |
| Test Jumpers..... | 102 |
| MEMORY EXPANSION | 102 |
| Configuring the MSV11-P | 103 |
| Starting Address..... | 105 |
| Control and Status Register (CSR) Address | 107 |
| Power | 108 |
| Bus Grant Continuity | 108 |
| General Jumpers | 108 |
| MASS STORAGE DISK EXPANSION | 108 |
| GABINET EXPANSION | 108 |
| Removal of Cabinet Side Panels..... | 110 |

APPENDIX A RELATED DOCUMENTATION

APPENDIX B PDP-11/23-PLUS GLOSSARY

FIGURES

| | | |
|------|---|-----|
| 1-1 | PDP-11/23-PLUS Computer System | 1 |
| 1-2 | Control Panel Switches and Indicators | 2 |
| 1-3 | Installation Checklist | 3 |
| 1-4 | RL02 Disk Drive (Front View)..... | 4 |
| 1-5 | Disk Cartridge Loading..... | 6 |
| 2-1 | Program Code and Name | 12 |
| 2-2 | DLDP + Help Message | 13 |
| 2-3 | Example of a Directory Listing..... | 13 |
| 2-4 | Example of a Diagnostic Chain | 14 |
| 3-1 | PDP-11/23-PLUS System Unpacking Instructions..... | 28 |
| 3-2 | Installation of Cabinet Legs and Stabilizer Foot..... | 29 |
| 3-3 | PDP-11/23-PLUS System (Rear Panel Removed)..... | 30 |
| 3-4 | RL02 Lower Disk Drive (Rear View)..... | 31 |
| 3-5 | 874 Power Controller (Front View) | 32 |
| 3-6 | PDP-11/23B Subsystem (Rear View) | 33 |
| 3-7 | PDP-11/23-PLUS System Cable Connections..... | 34 |
| 3-8 | RL02 Head Positioner Restraining Bracket..... | 35 |
| 3-9 | PDP-11/23-PLUS Control Panel Operation | 37 |
| 3-10 | PDP-11/23-PLUS Troubleshooting Flowchart | 38 |
| 4-1 | KDF11-B Diagnostic LED Display | 50 |
| 5-1 | PDP-11/23B Subsystem..... | 63 |
| 5-2 | Basic PDP-11/23-PLUS System's Module Location in an H9276 Backplane..... | 64 |
| 5-3 | KDF11-B Jumper, Switch, and Diagnostic Display Locations..... | 65 |
| 5-4 | MSV11-P Memory Factory Jumper Locations..... | 71 |
| 5-5 | DZV11 Factory Jumper and Switch Locations..... | 72 |
| 5-6 | RLV12 Factory Jumper Locations | 74 |
| 5-7 | BA11-S Major Assemblies..... | 75 |
| 5-8 | H9276 Connector and Jumper Locations..... | 75 |
| 5-9 | Control Panel Printed Circuit Board | 76 |
| 5-10 | PDP-11/23-PLUS Distribution Panel (H349)..... | 77 |
| 6-1 | Standard EIA Interface..... | 81 |
| 6-2 | Telephone Line Interface Via Data Set | 81 |
| 6-3 | VT100 Video Terminal | 82 |
| 6-4 | LA120 DECwriter III..... | 84 |
| 7-1 | PDP-11/23-PLUS Power Connectors | 87 |
| 8-1 | PDP-11/23-PLUS System (H9276) Two Backplane Configuration..... | 92 |
| 8-2 | PDP-11/23-PLUS System Three Backplane Configuration | 93 |
| 8-3 | KDF11-B Jumper, Switch, and Diagnostic Display Locations | 95 |
| 8-4 | MSV11-P Jumper Locations | 104 |
| 8-5 | CSR Bit Allocation | 107 |
| 8-6 | Left and Right Side Panel Removal..... | 111 |

TABLES

| | | |
|------|---|-----|
| 1-1 | Control Panel Operation | 3 |
| 1-2 | Control Panel LED Indicators | 3 |
| 1-3 | RL02 Front Panel Operation | 4 |
| 3-1 | Voltage and Range Selector Setting | 31 |
| 3-2 | System's Diagnostics | 36 |
| 4-1 | Dialog Commands | 46 |
| 4-2 | List of Error Halts | 47 |
| 4-3 | Diagnostic LED Error Display | 50 |
| 4-4 | DEC/X11-DLDP + Program Cross Reference | 58 |
| 5-1 | PDP-11/23-PLUS System Components | 62 |
| 5-2 | Factory Jumper Configuration | 66 |
| 5-3 | Bootstrap/Diagnostic Factory Switch Configuration | 68 |
| 5-4 | SLU Baud Rate Factory Switch Configuration | 68 |
| 5-5 | MSV11-P Versions | 69 |
| 5-6 | MSV11-P (M8067-LA and KA) Jumper Configuration | 69 |
| 5-7 | DZV11 (M7957) Jumper Configuration (Basic System) | 72 |
| 5-8 | DZV11 (M7957) Factory Switch Setting | 73 |
| 5-9 | Control Panel Jumpers | 76 |
| 5-10 | Distribution Panel Cable Assemblies to PDP-11/23-PLUS System Options | 78 |
| 7-1 | System Model Designations | 88 |
| 7-2 | Optional Console Terminals | 88 |
| 8-1 | CPU Jumper Configuration | 94 |
| 8-2 | On-Board Device Selection Jumpers | 96 |
| 8-3 | Diagnostic/Bootstrap Program Selection | 97 |
| 8-4 | Diagnostic/Bootstrap Program Switch Position | 97 |
| 8-5 | Bootstrap Program Selection | 98 |
| 8-6 | ROM-EPROM Jumpers | 98 |
| 8-7 | Baud Rate Selection | 99 |
| 8-8 | Character Format Jumpers | 100 |
| 8-9 | Character Jumper Configuration | 101 |
| 8-10 | Break Halt Jumper Configuration | 102 |
| 8-11 | Internal/External SLU Clock Jumper Configuration | 102 |
| 8-12 | Manufacturing Test Jumpers | 103 |
| 8-13 | Field Service Test Jumpers | 103 |
| 8-14 | Starting Address Configuration | 106 |
| 8-15 | CSR Address Selection | 108 |
| 8-16 | General Jumpers | 109 |
| 8-17 | PDP-11/23-PLUS Expansion Cabinets | 109 |

PREFACE

This manual provides the user with information on the operation, configuration, and maintenance for the PDP-11/23-PLUS system. It describes both the hardware and software operating features of the system. The configuration requirements are explained, and the factory configuration is defined. The manual includes software diagnostic programs used to troubleshoot the system and a hardware system checkout procedure.

NOTE: The dialog used by the operator when communicating with the system is printed in orange.

Specifications for the optional terminals appear in Chapter 6. Chapter 8 presents the rules for expanding the system. All address references such as registers, software locations, and interrupt vectors are octal numbers.

CHAPTER 1 GETTING STARTED

INTRODUCTION

The PDP-11/23-PLUS is a high performance microcomputer system used for developing and executing programs for a variety of applications. Optional hardware and software are available for applications such as high-level language program development, foreground/background real-time support, multiprogramming, and equipment monitoring and control.

The PDP-11/23-PLUS (Figure 1-1) includes an operator's switch panel, a processor with memory management functions, a 256K byte memory (expandable to 1 megabyte), a 2-channel serial line interface, and two RL02 disk drives. The memory supports the extended LSI-11 bus (22-bit address). Each disk drive has a removable top-loading disk cartridge that provides 10 million bytes of storage. Special bootstrap read-only memories (ROM) initiate the system software when the system is turned on and can also automatically test the system.

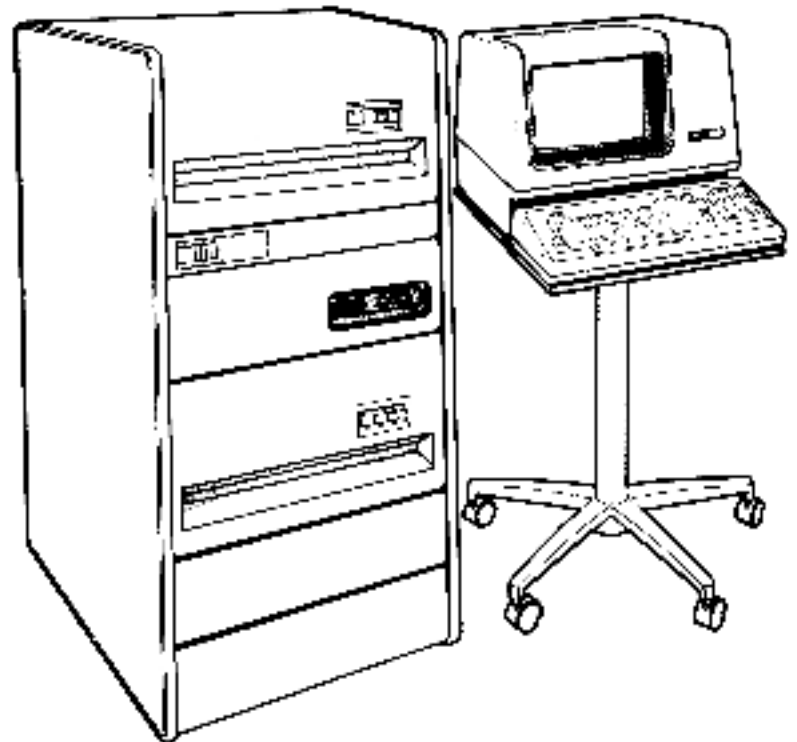

11-123C

Figure 1-1 PDP-11/23-PLUS Computer System

DIGITAL provides either an LA 120 DECwriter III, VT100, or VT102 terminal for the PDP-11/23-PLUS system (see Chapter 6). The system terminal implements communication between the user and the processor. Interface with the system and the user's terminal is provided by a patch and filter panel located at the rear of the system's cabinet. Chapter 5 contains a complete description of the PDP-11/23-PLUS.

CONTROL PANEL

Control panel switches provide power, stop, and bootstrap communications between the user and the microcomputer system. This panel contains three switches: AUX ON/OFF, HALT, and RESTART. Switch locations are shown in Figure 1-2, and their operation is listed in Table 1-1.

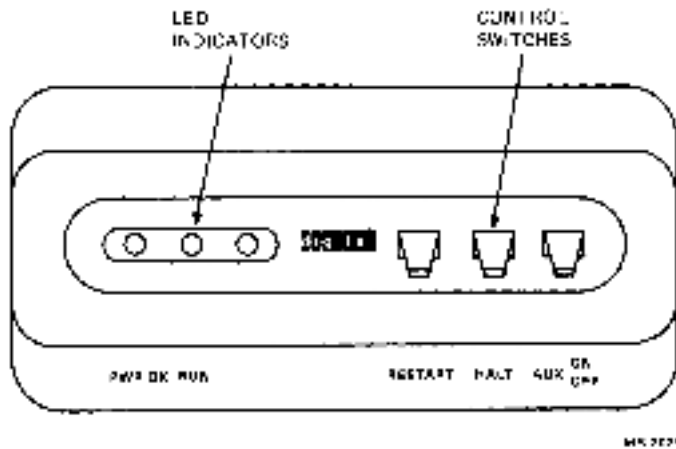

Figure 1-2 Control Panel Switches and Indicators

The switch panel contains three LED indicators, but only two are used: POWER OK and RUN. Their operation is listed in Table 1-2.

SYSTEM CONFIGURATION

The PDP-11/23-PLUS is configured and tested at the factory and is ready to be installed at the user's site. Several features can be changed when the system is installed by DIGITAL's Field Service. Figure 1-3 is a checklist to use as a reminder of the desired configuration when the system is installed.

RL02 Disk Drives

The RL02 disk drive is a random-access, mass storage device with a removable, top-loading disk cartridge. A cover lifts up to gain access to the disk. The RL02 has four indicators on its front panel, as shown in Figure 1-4. Their operation is listed in Table 1-3.

Table 1-1 Control Panel Operation

| Switch | Position | Function |
|---------------|----------------------------------|---|
| AUX ON/OFF | OFF | In the normal factory configuration, setting this switch to off turns off the system ac power. |
| | ON | In the normal factory configuration, setting this switch to on turns on the system ac power. If the HALT switch is also up, the system automatically boots at this time. |
| HALT | Up (Enable) | Placing this switch up enables the processor to run. |
| | Down (Halt) | The processor halts and responds to console ODT commands. Refer to the <i>Microcomputer and Memories Handbook</i> for ODT instructions. |
| RESTART | RESTART (momentary switch) | When the Halt switch is up, the processor carries out a power-up sequence and displays the bootstrap dialog as below. TESTING MEMORY 0256.KW MEMORY START ? DL0-<CR> |

Table 1-2 Control Panel LED Indicators

| LED | Function |
|--------|--|
| PWR OK | This LED is on when the processor is generating correct dc output voltages. |
| RUN | This LED is on when the processor is operating; the LED goes off when the processor is not executing instructions. |

NOTE: It is possible that this indicator may blink. It should be ignored when the ODT character is enabled.

| <u>OPTIONAL FEATURE</u> | <u>CHECK DESIRED CONFIGURATION</u> | |
|-------------------------|------------------------------------|--|
| UNIT 0/UNIT 1 | TOP SOCKET | <input type="checkbox"/> UNIT 0 UNIT 1 <input type="checkbox"/> UNIT 1 UNIT 0 |
| BREAK KEY FUNCTION | | <input type="checkbox"/> DISABLE <input type="checkbox"/> HALT SYSTEM |
| RECEIVE SPEED | | <input type="checkbox"/> 9600 BAUD (AS SHIPPED) <input type="checkbox"/> CHANGE TO * _____ |
| TRANSMIT SPEED | | <input type="checkbox"/> 9600 BAUD (AS SHIPPED) <input type="checkbox"/> CHANGE TO * _____ |
| BOOTSTRAP TECHNIQUE | | <input type="checkbox"/> DIALOG USING D, O OR DL1 <input type="checkbox"/> AUTOMATIC |

* TRANSMIT AND RECEIVE SPEED MUST MATCH TERMINAL

101-100

Figure 1-3 Installation Checklist

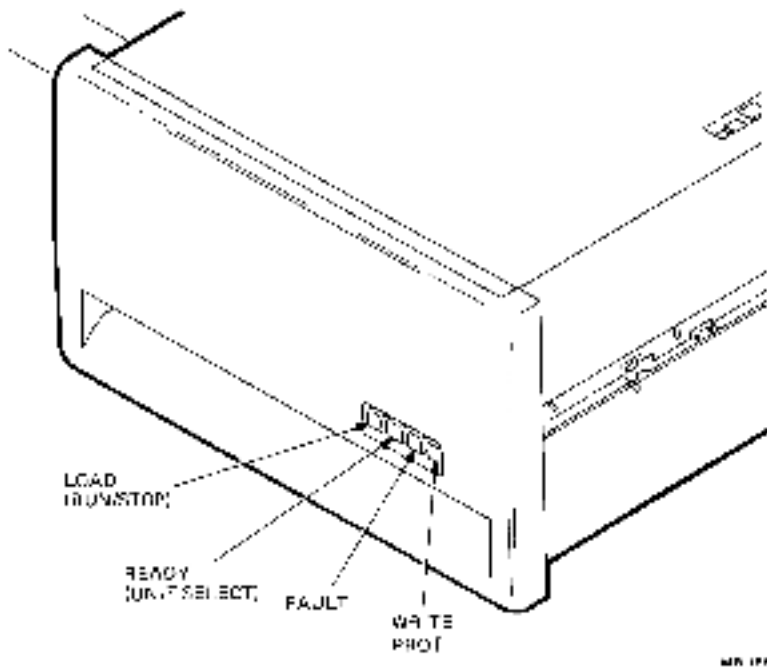

Figure 1-4 RL02 Disk Drive (Front View)

Table 1-3 RL02 Front Panel Operation

| Indicator | Function |
|-----------------------------|--|
| LOAD (push-button) | Lights to indicate that the spindle has stopped and a cartridge can be loaded. |
| UNIT SELECT (READY) | Lights to indicate that drive 0 or 1 is ready to read, write, or receive controller commands. |
| FAULT | Lights to indicate that a drive error condition exists. |
| WRITE PROT (push-button) | Lights to indicate that the cartridge currently mounted is protected from having data written on it. |

BREAK Key

The BREAK key is factory configured to halt the system. For the convenience of the operator, who must be aware of its function, the BREAK key can be disabled so that it is ignored when typed. The key is normally located near the RETURN key. If the BREAK key is set to halt and is accidentally typed, it could halt the system in the middle of a program. To change the configuration, refer to the terminal's user guide (listed in Appendix A).

Receive Speed/Transmit Speed

The receive and transmit speeds are factory configured to 9600 baud. This is the normal speed for the VT100, VT102, and LA120 DECwriter terminals. To change the baud rates refer to the terminal's user guide (listed in Appendix A).

Bootstrap Technique

The user can select either an automatic boot or an operator-controlled boot. To use either boot, the HALT switch must be set to ENABLE and the AUX ON/OFF switch turned ON. The operator-controlled boot requires the operator to indicate which bootable disk drive, DL0 or DL1, has been selected.

DISK CARTRIDGE LOADING PROCEDURE

Use the following procedure to load a disk cartridge (Figure 1-5).

1. Turn the power on with the AUX ON/OFF switch (Figure 1-2). After 15 seconds, the LOAD indicator on each drive should light.

NOTE: A safety interlock prevents the opening of the RL02 cartridge access door when no power is available to the drive. Check that the RL02 head restraining bracket is in its proper position, as shown in Figure 3-8.

2. Raise the cartridge access door, as shown in Figure 1-5.
3. Support cartridge (A) with left hand.
4. Push handle slide (C) to left with thumb of right hand.
5. Raise cover handle (D) to full upright position, releasing protection cover (B).
6. Lift cartridge (A) from protection cover (B) and carefully seat it on drive spindle with the handle recess facing the rear of the drive.
7. Carefully rotate top cover handle (D) a few degrees clockwise and counterclockwise to ensure that it seats firmly.
8. Gently lower the top cover handle (D) to the horizontal position to engage the cartridge on the drive spindle.
9. Place protection cover (B) on top of the cartridge.
10. Close the cartridge access door.

8 GETTING STARTED

11. Press the LOAD indicator button. Note that the LOAD indicator goes out; and, after 30 seconds, the unit-select (READY) indicator illuminates.
12. If write protection is desired, press the WRITE PROT indicator button.

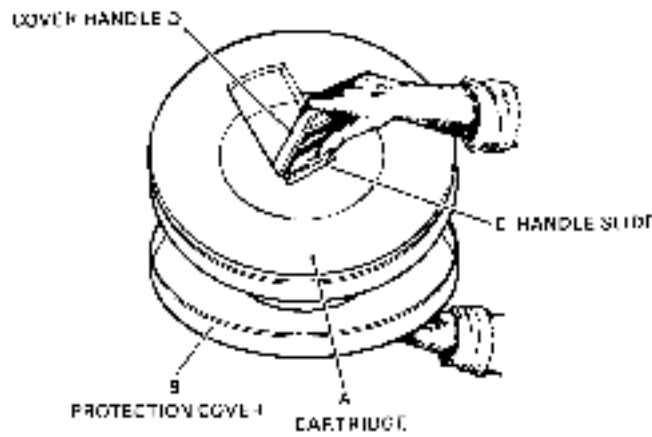
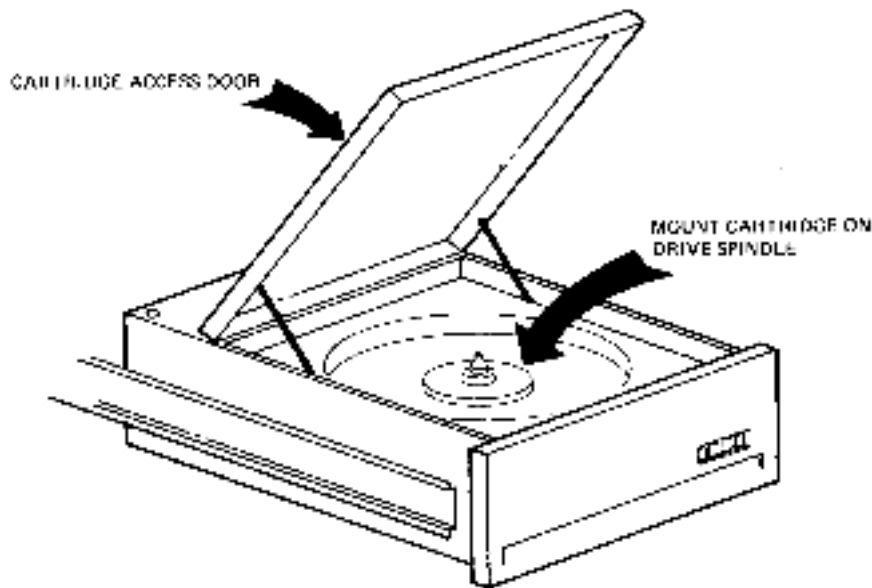

UP LMC

Figure 1-5 Disk Cartridge Loading

INITIAL SYSTEM START-UP

The recommended system start-up sequence is listed below. If the system does not respond as noted, refer to Chapter 4 for further instructions.

1. Check that your terminal is configured as follows.
 - a. Power ON/OFF switch is set to ON.
 - b. LINE/LOCAL mode is set to LINE.
 - c. FDX/HDX is set to FDX (full-duplex).
 - d. BAUD RATE matches the system.

2. Set switches on the PDP-11/23-PLUS control panel as follows.
 - a. Set the HALT switch up (enable).
 - b. Set the AUX ON/OFF switch to ON. In approximately 15 seconds, the PWR OK and LOAD indicators will light.

NOTE The FAULT indicator may also light at this time. It should go off, however, as soon as the disk drive is accessed. If it does not go off, consult Figure 3-10, the PDP-11/23-PLUS Troubleshooting Flowchart, or your local DIGITAL Field Service office.

3. Ensure that the system software disk cartridge is READY and write protected. Press the WRITE PROT indicator button on the RLO2 if it is not illuminated.

NOTE: Operating systems normally require that the system disk be write enabled; however, do not enable it until the master cartridge has been copied.

LOADING THE OPERATING SYSTEM

Before the computer can read the programs on the disk cartridge, the disk drive must be bootstrapped. The bootstrap is a short program that establishes a communication path between the computer and the disk drive. Once the bootstrap program has been executed, the computer can interact with the disk drive to use the operating system programs contained on the disk. To boot disk drive 0 (usually the upper disk), proceed as follows.

NOTE: In this manual, examples of commands that are typed by the operator are printed in orange. Characters that are printed or displayed by the computer appear in black type.

Characters enclosed by < > brackets are nonprinting commands. For example, <CR> indicates carriage return, and the operator should press the RETURN key.

B GETTING STARTED

When the AUX ON/OFF switch is turned ON (after a halt, press the RESTART switch momentarily), the computer prints the following on the terminal. (If a video terminal is used, allow a short warm-up period until the cursor appears on the screen.)

```
TESTING MEMORY
Q256.KW
START?
```

The bootstrap and diagnostic software program automatically sizes the available memory in the system. The actual available memory maximum is 1 megabyte. The user should be aware of the actual memory and not depend on the printout. If the displayed memory size does not agree with the actual memory size in the system, a hardware problem may exist. Consult your local DIGITAL Field Service office.

Type "DLO" and the RETURN key after the "START?".

```
START? DLO<CR.>
```

The processor reads from the disk and, after several seconds, prints the name of the operating system and the system monitor.

When the processor prints the monitor name, it indicates that the operating system is now controlling the computer and monitoring the keyboard. RSX (Real Time Executive) uses (:>) as a prompt character to signal that it is waiting for a command from the operator.

At this time, the system is ready for the user's application. It is advisable to copy the disk onto a spare cartridge and store the original as a backup copy.

CHANGING A DISK CARTRIDGE

Before a disk cartridge is changed, it is very important to make certain that the cartridge is not being accessed. On a single-user system this is relatively easy to do. On a multiuser system, however, it is more difficult to determine whether a cartridge is in use. Each active user must be consulted before dismounting a disk cartridge. Once it is certain that there is no risk involved in changing the disk cartridge, use the following procedure.

1. Press the LOAD button on the RL02 drive.
 - a. The disk stops rotating.
 - b. After several seconds, the LOAD indicator illuminates on the RL02.
2. Remove the disk cartridge.

3. Raise the cartridge access door (Figure 1-5).
4. Remove the cartridge protection cover previously stored on top of the disk cartridge within the drive. Hold this protection cover in your left hand.
5. Push the handle slide on the disk handle to the left with your thumb while raising the handle with your right hand.
6. Raise the handle to a full upright position to release the cartridge from the drive spindle.
7. Carefully lift the cartridge up and out of the drive, and place it in the protection cover.
8. Lower the top cover handle to the horizontal position to lock the protection cover in place.

POWERING DOWN

The LOAD indicator on each drive should be illuminated before the power is turned off. Programs in progress should be completed before the disk drives are switched to LOAD. The system can be turned off as follows.

1. Press the LOAD button on each RL02 drive, if necessary, to ensure that both disk drive LOAD indicators are illuminated on the RL02.
2. Set the AUX ON/OFF switch (Figure 1-2) on the control panel to OFF. The PWR OK indicator on the control panel should turn off, and the fans will stop.

NOTE: The 874 power controller still has ac power applied, but power has been removed from the switched outlets.

3. To remove ac power, open the backpanel (see Chapter 3); and set the circuit breaker on the 874 power controller to OFF, or remove the power cable from the ac outlet. In most cases, ac power is not removed except for servicing or during lengthy periods of disuse.
4. Turn off ac power to the system's terminal.

CHAPTER 2 PROGRAMMING

INTRODUCTION

The PDP-11/23-PLUS software consists of diagnostic programs and system operation programs. The diagnostic programs include the DEC/X11, the DLDP+, and other small programs implemented in the system hardware. DEC/X11 programs diagnose problems that occur in the interaction of system components, while DLDP+ programs diagnose problems that occur within the individual components of the system.

The system operation programs use either RSX-11M, RSX-11M-PLUS, RSTS/E, or CTS-500 software. These are real-time multiprogramming systems, capable of executing two or more concurrent programs.

DIAGNOSTIC PROGRAMS

Diagnostic programs help to verify that the system is working correctly or to isolate malfunctions of the failing part. They are used for maintenance purposes and play no part in normal system operation (except automatically during the system power-up sequence). There are three groups of diagnostic programs for the PDP-11/23-PLUS: the DEC/X11 system exerciser software, the DLDP+ component diagnostic software, and the bootstrap and diagnostic hardware-implemented programs.

The DEC/X11 software system consists of a collection of diagnostic programs as well as the monitor and utility programs necessary to generate, run, control, and update these diagnostic programs. The DEC/X11 run-time exerciser is a combination of individual programs chained together to produce an interactive system. It exercises and checks the PDP-11/23-PLUS's reliability as an integrated system. Each PDP-11/23-PLUS system is shipped with a DEC/X11 run-time exerciser factory configured for the requirements of that individual system.

DLDP+ diagnostic software also consists of a collection of diagnostic programs as well as the monitor and utility programs. DLDP+ programs, however, are designed to diagnose individual system components rather than to exercise the overall computer system.

A third group of diagnostic programs is built into the computer hardware and does not have to be loaded from a disk. The boot and diagnostic read-only memory contains both CPU and memory diagnostics that are automatically executed when bootstrapping the system. Chapter 4 describes the operation of the bootstrap and diagnostic programs.

The remaining diagnostic tool is the hardware on-line debugging technique (ODT). This is built into the computer processor and is the most basic means of communicating with the computer. The ODT commands allow the operator to use the terminal for functions normally available on a control panel containing an array of lights and switches. Chapter 4 further describes the ODT commands.

The DLDP+ Diagnostic Programs

The DLDP+ diagnostic kit contains programs that are configured for an RL02 disk-based system such as the PDP-11/23-PLUS. As received, the diagnostic kit is configured to test the PDP-11/23-PLUS system. If the system is expanded, other programs may be requested. Instructions for program modification and addition are presented in the *XXDP+/SUPR User's Manual*.

Program listings for the individual diagnostics explain the purpose, use, and interpretation of the individual programs.

How to Find a Diagnostic Program – Each diagnostic program has a product code that appears on the title page of its listing and a file name used to call it from the disk. This file name is derived from the diagnostic code, as illustrated in Figure 2-1. The revision of the program and the revision status (program changes that have been added) are also included.

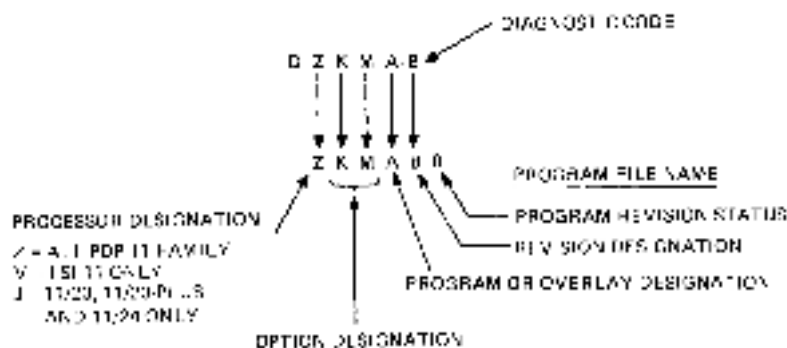

DLDP+

Figure 2-1 Program Code and Name

A list of file names is obtained directly from the disk by calling for a directory listing. To do this, load the diagnostic disk cartridge into the disk drive and bootstrap the drive. The system prints the title of the diagnostic software system, a help message (Figure 2-2), and the prompt character. After the prompt, type the D command to get a directory listing of the contents of the disk.

```
> D<CR>
```

Figure 2-3 is an example of a directory listing. The mnemonics in the FILENAM column are the file names. These correspond to the product codes shown in Figure 2-1. Note that the last character in the file name is a number (0, 1, etc.) indicating the revision status of the program. If the letter O is typed instead of the number 0, the program will not run.

```

TESTING MEMCR*
0001.KM
START: 01.

CONNECT WITH DL POSITION
SCOTED VCA UNIT 1
JBR
DOES THE SYSTEM HAVE A MICROST 17A DRIVE IN
NOW UNDER SYSTEM

ENTER DATE (DD-MMM-YY) 1-01-81

RESTART ADDR: 152010
THIS IS XDP4+. TYPE 'H' OR 'HELP' FOR HELP.

JNL
D:MENU 0001-HELP TEST FILE 0001-0001 0-000000

```

0001-0000

Figure 2-2 DLDP + Help Message

| ENTRY# | FILENAME | DATE | LENGTH | START |
|--------|----------|----------|--------|--------|
| 1 | HMFBLSYS | 18-01-81 | 17 | 000012 |
| 2 | HMFBLSYS | 18-01-81 | 17 | 000015 |
| 3 | HMFBLSYS | 18-01-81 | 17 | 000018 |
| 4 | HMFBLSYS | 18-01-81 | 17 | 000021 |
| 5 | HMFBLSYS | 18-01-81 | 17 | 000024 |
| 6 | HMFBLSYS | 18-01-81 | 17 | 000027 |
| 7 | HMFBLSYS | 18-01-81 | 17 | 000030 |
| 8 | HMFBLSYS | 18-01-81 | 17 | 000033 |
| 9 | HMFBLSYS | 18-01-81 | 17 | 000036 |
| 10 | HMFBLSYS | 18-01-81 | 17 | 000039 |
| 11 | HMFBLSYS | 18-01-81 | 17 | 000042 |
| 12 | HMFBLSYS | 18-01-81 | 17 | 000045 |
| 13 | HMFBLSYS | 18-01-81 | 17 | 000048 |
| 14 | HMFBLSYS | 18-01-81 | 17 | 000051 |

0001-0000

Figure 2-3 Example of a Directory Listing

Help Messages – Help messages are included on each disk to assist the user in implementing the diagnostic operations. The messages normally list the DLDP+ commands needed to use the disk programs and a brief explanation of their operation. The help messages are aborted by typing the CTRL C command. A typical help message is shown in Figure 2-2, and more detailed explanations are presented in the *XXDP+/SUPR User's Manual* supplied with the software. To request a help message type the following.

```
H<:CR>
```

Diagnostic Chain Files – The initial program modification sets up a file of chained diagnostics. This file is a "quick verify" test to check the processor but not the disk drive system or system options. The test takes approximately 30 minutes.

To start the quick verify test, type the following command.

```
.C 11T23B<:CR>
```

If a chained diagnostic program fails, it can be run separately from the chain to recheck the hardware. See Figure 2-4 for an example of a successful diagnostic chain file output. The ??'s indicate the latest revision.

```

1 11T23B
2
3      L1T23B QUICK VERIFY DIAGNOSTIC CHAIN
4
5      F-11 D11 DIAGNOSTIC (RE-11-C1001)
6  LK001?
7
8  CHECKED (RE-11-AA CPU DIAGNOSTIC
9  (RE-11-PASS 4      01      F-11 D11 CPU DIAGNOSTIC (RE-11-C1001)
10 LK001??
11
12 CHECKED (RE-11-AA CPU DIAG.
13
14 (RE-11-PASS 4      1      F-11 D11 CPU DIAGNOSTIC (RE-11-C1001)
15 01      01      01      01      01      01      01      01
16 01      01      01      01      01      01      01      01
17 01      01      01      01      01      01      01      01
18 01      01      01      01      01      01      01      01
19 01      01      01      01      01      01      01      01
20 01      01      01      01      01      01      01      01
21 01      01      01      01      01      01      01      01
22 01      01      01      01      01      01      01      01
23 01      01      01      01      01      01      01      01
24 01      01      01      01      01      01      01      01
25 01      01      01      01      01      01      01      01
26 01      01      01      01      01      01      01      01
27 01      01      01      01      01      01      01      01
28 01      01      01      01      01      01      01      01
29 01      01      01      01      01      01      01      01
30 01      01      01      01      01      01      01      01
31 01      01      01      01      01      01      01      01
32 01      01      01      01      01      01      01      01
33 01      01      01      01      01      01      01      01
34 01      01      01      01      01      01      01      01
35 01      01      01      01      01      01      01      01
36 01      01      01      01      01      01      01      01
37 01      01      01      01      01      01      01      01
38 01      01      01      01      01      01      01      01
39 01      01      01      01      01      01      01      01
40 01      01      01      01      01      01      01      01
41 01      01      01      01      01      01      01      01
42 01      01      01      01      01      01      01      01
43 01      01      01      01      01      01      01      01
44 01      01      01      01      01      01      01      01
45 01      01      01      01      01      01      01      01
46 01      01      01      01      01      01      01      01
47 01      01      01      01      01      01      01      01
48 01      01      01      01      01      01      01      01
49 01      01      01      01      01      01      01      01
50 01      01      01      01      01      01      01      01
51 01      01      01      01      01      01      01      01
52 01      01      01      01      01      01      01      01
53 01      01      01      01      01      01      01      01
54 01      01      01      01      01      01      01      01
55 01      01      01      01      01      01      01      01
56 01      01      01      01      01      01      01      01
57 01      01      01      01      01      01      01      01
58 01      01      01      01      01      01      01      01
59 01      01      01      01      01      01      01      01
60 01      01      01      01      01      01      01      01
61 01      01      01      01      01      01      01      01
62 01      01      01      01      01      01      01      01
63 01      01      01      01      01      01      01      01
64 01      01      01      01      01      01      01      01
65 01      01      01      01      01      01      01      01
66 01      01      01      01      01      01      01      01
67 01      01      01      01      01      01      01      01
68 01      01      01      01      01      01      01      01
69 01      01      01      01      01      01      01      01
70 01      01      01      01      01      01      01      01
71 01      01      01      01      01      01      01      01
72 01      01      01      01      01      01      01      01
73 01      01      01      01      01      01      01      01
74 01      01      01      01      01      01      01      01
75 01      01      01      01      01      01      01      01
76 01      01      01      01      01      01      01      01
77 01      01      01      01      01      01      01      01
78 01      01      01      01      01      01      01      01
79 01      01      01      01      01      01      01      01
80 01      01      01      01      01      01      01      01
81 01      01      01      01      01      01      01      01
82 01      01      01      01      01      01      01      01
83 01      01      01      01      01      01      01      01
84 01      01      01      01      01      01      01      01
85 01      01      01      01      01      01      01      01
86 01      01      01      01      01      01      01      01
87 01      01      01      01      01      01      01      01
88 01      01      01      01      01      01      01      01
89 01      01      01      01      01      01      01      01
90 01      01      01      01      01      01      01      01
91 01      01      01      01      01      01      01      01
92 01      01      01      01      01      01      01      01
93 01      01      01      01      01      01      01      01
94 01      01      01      01      01      01      01      01
95 01      01      01      01      01      01      01      01
96 01      01      01      01      01      01      01      01
97 01      01      01      01      01      01      01      01
98 01      01      01      01      01      01      01      01
99 01      01      01      01      01      01      01      01
100 01      01      01      01      01      01      01      01
101 01      01      01      01      01      01      01      01
102 01      01      01      01      01      01      01      01
103 01      01      01      01      01      01      01      01
104 01      01      01      01      01      01      01      01
105 01      01      01      01      01      01      01      01
106 01      01      01      01      01      01      01      01
107 01      01      01      01      01      01      01      01
108 01      01      01      01      01      01      01      01
109 01      01      01      01      01      01      01      01
110 01      01      01      01      01      01      01      01
111 01      01      01      01      01      01      01      01
112 01      01      01      01      01      01      01      01
113 01      01      01      01      01      01      01      01
114 01      01      01      01      01      01      01      01
115 01      01      01      01      01      01      01      01
116 01      01      01      01      01      01      01      01
117 01      01      01      01      01      01      01      01
118 01      01      01      01      01      01      01      01
119 01      01      01      01      01      01      01      01
120 01      01      01      01      01      01      01      01
121 01      01      01      01      01      01      01      01
122 01      01      01      01      01      01      01      01
123 01      01      01      01      01      01      01      01
124 01      01      01      01      01      01      01      01
125 01      01      01      01      01      01      01      01
126 01      01      01      01      01      01      01      01
127 01      01      01      01      01      01      01      01
128 01      01      01      01      01      01      01      01
129 01      01      01      01      01      01      01      01
130 01      01      01      01      01      01      01      01
131 01      01      01      01      01      01      01      01
132 01      01      01      01      01      01      01      01
133 01      01      01      01      01      01      01      01
134 01      01      01      01      01      01      01      01
135 01      01      01      01      01      01      01      01
136 01      01      01      01      01      01      01      01
137 01      01      01      01      01      01      01      01
138 01      01      01      01      01      01      01      01
139 01      01      01      01      01      01      01      01
140 01      01      01      01      01      01      01      01
141 01      01      01      01      01      01      01      01
142 01      01      01      01      01      01      01      01
143 01      01      01      01      01      01      01      01
144 01      01      01      01      01      01      01      01
145 01      01      01      01      01      01      01      01
146 01      01      01      01      01      01      01      01
147 01      01      01      01      01      01      01      01
148 01      01      01      01      01      01      01      01
149 01      01      01      01      01      01      01      01
150 01      01      01      01      01      01      01      01
151 01      01      01      01      01      01      01      01
152 01      01      01      01      01      01      01      01
153 01      01      01      01      01      01      01      01
154 01      01      01      01      01      01      01      01
155 01      01      01      01      01      01      01      01
156 01      01      01      01      01      01      01      01
157 01      01      01      01      01      01      01      01
158 01      01      01      01      01      01      01      01
159 01      01      01      01      01      01      01      01
160 01      01      01      01      01      01      01      01
161 01      01      01      01      01      01      01      01
162 01      01      01      01      01      01      01      01
163 01      01      01      01      01      01      01      01
164 01      01      01      01      01      01      01      01
165 01      01      01      01      01      01      01      01
166 01      01      01      01      01      01      01      01
167 01      01      01      01      01      01      01      01
168 01      01      01      01      01      01      01      01
169 01      01      01      01      01      01      01      01
170 01      01      01      01      01      01      01      01
171 01      01      01      01      01      01      01      01
172 01      01      01      01      01      01      01      01
173 01      01      01      01      01      01      01      01
174 01      01      01      01      01      01      01      01
175 01      01      01      01      01      01      01      01
176 01      01      01      01      01      01      01      01
177 01      01      01      01      01      01      01      01
178 01      01      01      01      01      01      01      01
179 01      01      01      01      01      01      01      01
180 01      01      01      01      01      01      01      01
181 01      01      01      01      01      01      01      01
182 01      01      01      01      01      01      01      01
183 01      01      01      01      01      01      01      01
184 01      01      01      01      01      01      01      01
185 01      01      01      01      01      01      01      01
186 01      01      01      01      01      01      01      01
187 01      01      01      01      01      01      01      01
188 01      01      01      01      01      01      01      01
189 01      01      01      01      01      01      01      01
190 01      01      01      01      01      01      01      01
191 01      01      01      01      01      01      01      01
192 01      01      01      01      01      01      01      01
193 01      01      01      01      01      01      01      01
194 01      01      01      01      01      01      01      01
195 01      01      01      01      01      01      01      01
196 01      01      01      01      01      01      01      01
197 01      01      01      01      01      01      01      01
198 01      01      01      01      01      01      01      01
199 01      01      01      01      01      01      01      01
200 01      01      01      01      01      01      01      01
201 01      01      01      01      01      01      01      01
202 01      01      01      01      01      01      01      01
203 01      01      01      01      01      01      01      01
204 01      01      01      01      01      01      01      01
205 01      01      01      01      01      01      01      01
206 01      01      01      01      01      01      01      01
207 01      01      01      01      01      01      01      01
208 01      01      01      01      01      01      01      01
209 01      01      01      01      01      01      01      01
210 01      01      01      01      01      01      01      01
211 01      01      01      01      01      01      01      01
212 01      01      01      01      01      01      01      01
213 01      01      01      01      01      01      01      01
214 01      01      01      01      01      01      01      01
215 01      01      01      01      01      01      01      01
216 01      01      01      01      01      01      01      01
217 01      01      01      01      01      01      01      01
218 01      01      01      01      01      01      01      01
219 01      01      01      01      01      01      01      01
220 01      01      01      01      01      01      01      01
221 01      01      01      01      01      01      01      01
222 01      01      01      01      01      01      01      01
223 01      01      01      01      01      01      01      01
224 01      01      01      01      01      01      01      01
225 01      01      01      01      01      01      01      01
226 01      01      01      01      01      01      01      01
227 01      01      01      01      01      01      01      01
228 01      01      01      01      01      01      01      01
229 01      01      01      01      01      01      01      01
230 01      01      01      01      01      01      01      01
231 01      01      01      01      01      01      01      01
232 01      01      01      01      01      01      01      01
233 01      01      01      01      01      01      01      01
234 01      01      01      01      01      01      01      01
235 01      01      01      01      01      01      01      01
236 01      01      01      01      01      01      01      01
237 01      01      01      01      01      01      01      01
238 01      01      01      01      01      01      01      01
239 01      01      01      01      01      01      01      01
240 01      01      01      01      01      01      01      01
241 01      01      01      01      01      01      01      01
242 01      01      01      01      01      01      01      01
243 01      01      01      01      01      01      01      01
244 01      01      01      01      01      01      01      01
245 01      01      01      01      01      01      01      01
246 01      01      01      01      01      01      01      01
247 01      01      01      01      01      01      01      01
248 01      01      01      01      01      01      01      01
249 01      01      01      01      01      01      01      01
250 01      01      01      01      01      01      01      01
251 01      01      01      01      01      01      01      01
252 01      01      01      01      01      01      01      01
253 01      01      01      01      01      01      01      01
254 01      01      01      01      01      01      01      01
255 01      01      01      01      01      01      01      01
256 01      01      01      01      01      01      01      01
257 01      01      01      01      01      01      01      01
258 01      01      01      01      01      01      01      01
259 01      01      01      01      01      01      01      01
260 01      01      01      01      01      01      01      01
261 01      01      01      01      01      01      01      01
262 01      01      01      01      01      01      01      01
263 01      01      01      01      01      01      01      01
264 01      01      01      01      01      01      01      01
265 01      01      01      01      01      01      01      01
266 01      01      01      01      01      01      01      01
267 01      01      01      01      01      01      01      01
268 01      01      01      01      01      01      01      01
269 01      01      01      01      01      01      01      01
270 01      01      01      01      01      01      01      01
271 01      01      01      01      01      01      01      01
272 01      01      01      01      01      01      01      01
273 01      01      01      01      01      01      01      01
274 01      01      01      01      01      01      01      01
275 01      01      01      01      01      01      01      01
276 01      01      01      01      01      01      01      01
277 01      01      01      01      01      01      01      01
278 01      01      01      01      01      01      01      01
279 01      01      01      01      01      01      01      01
280 01      01      01      01      01      01      01      01
281 01      01      01      01      01      01      01      01
282 01      01      01      01      01      01      01      01
283 01      01      01      01      01      01      01      01
284 01      01      01      01      01      01      01      01
285 01      01      01      01      01      01      01      01
286 01      01      01      01      01      01      01      01
287 01      01      01      01      01      01      01      01
288 01      01      01      01      01      01      01      01
289 01      01      01      01      01      01      01      01
290 01      01      01      01      01      01      01      01
291 01      01      01      01      01      01      01      01
292 01      01      01      01      01      01      01      01
293 01      01      01      01      01      01      01      01
294 01      01      01      01      01      01      01      01
295 01      01      01      01      01      01      01      01
296 01      01      01      01      01      01      01      01
297 01      01      01      01      01      01      01      01
298 01      01      01      01      01      01      01      01
299 01      01      01      01      01      01      01      01
300 01      01      01      01      01      01      01      01
301 01      01      01      01      01      01      01      01
302 01      01      01      01      01      01      01      01
303 01      01      01      01      01      01      01      01
304 01      01      01      01      01      01      01      01
305 01      01      01      01      01      01      01      01
306 01      01      01      01      01      01      01      01
307 01      01      01      01      01      01      01      01
308 01      01      01      01      01      01      01      01
309 01      01      01      01      01      01      01      01
310 01      01      01      01      01      01      01      01
311 01      01      01      01      01      01      01      01
312 01      01      01      01      01      01      01      01
313 01      01      01      01      01      01      01      01
314 01      01      01      01      01      01      01      01
315 01      01      01      01      01      01      01      01
316 01      01      01      01      01      01      01      01
317 01      01      01      01      01      01      01      01
318 01      01      01      01      01      01      01      01
319 01      01      01      01      01      01      01      01
320 01      01      01      01      01      01      01      01
321 01      01      01      01      01      01      01      01
322 01      01      01      01      01      01      01      01
323 01      01      01      01      01      01      01      01
324 01      01      01      01      01      01      01      01
325 01      01      01      01      01      01      01      01
326 01      01      01      01      01      01      01      01
327 01      01      01      01      01      01      01      01
328 01      01      01      01      01      01      01      01
329 01      01      01      01      01      01      01      01
330 01      01      01      01      01      01      01      01
331 01      01      01      01      01      01      01      01
332 01      01      01      01      01      01      01      01
333 01      01      01      01      01      01      01      01
334 01      01      01      01      01      01      01      01
335 01      01      01      01      01      01      01      01
336 01      01      01      01      01      01      01      01
337 01      01      01      01      01      01      01      01
338 01      01      01      01      01      01      01      01
339 01      01      01      01      01      01      01      01
340 01      01      01      01      01      01      01      01
341 01      01      01      01      01      01      01      01
342 01      01      01      01      01      01      01      01
343 01      01      01      01      01      01      01      01
344 01      01      01      01      01      01      01      01
345 01      01      01      01      01      01      01      01
346 01      01      01      01      01      01      01      01
347 01      01      01      01      01      01      01      01
348 01      01      01      01      01      01      01      01
349 01      01      01      01      01      01      01      01
350 01      01      01      01      01      01      01      01

```

This example runs the RLV12 disk controller test. A listing of the directory may be necessary to obtain the current revision and status of the program desired.

How to Copy the Diagnostic Disk

The diagnostic software can be copied onto a spare disk cartridge by using the COPY utility program. This program transfers the entire contents of one disk (DLDP+ diagnostics, DEC:XX11 exerciser, monitor, utilities, and user-generated files) onto another disk.

CAUTION: Care must be exercised when using the COPY command. If the source and destination codes are wrong and the source disk is not write protected, the system can copy a blank disk onto a master disk, thereby destroying the master.

Copy a diagnostic disk as follows.

1. Load the diagnostic disk cartridge into disk drive 0. Press the WRITE PROT push button, if necessary, so that the WRITE PROT indicator on disk drive 0 is on.
2. Load a blank RL02 cartridge into disk drive 1. Press the WRITE PROT push button, if necessary, so that the WRITE PROT indicator on disk drive 1 is off.
3. Initialize the system by pressing RESTART. The system responds with "256KW START" or a similar response. Boot the system by typing "DL0" and the RETURN key. The system responds by printing the program heading and asking the operator to enter the date.

```
TESTING MEMORY
0256KW MEMORY
START? DL0<CR>
```

```
C TIMDL02 XXDP+ DL MONITOR
BOOTED VIA UNIT 0
```

```
28K
DOES THE SYSTEM HAVE UNIBUS (Y/N CR — Y)
ENTER DATE (DD-MMM-YY):
```

4. Enter the date as follows: 14-OCT-81. Press the RETURN key, and the system responds as follows.

```
ENTER DATE (DD-MMM-YY): 14-OCT-81<CR>
```

```
RESTART ADDR: 152010
THIS IS XXDP+. TYPE "H" OR "H/L" FOR HELP
```

- The "." is the system monitor. Run diagnostics by typing "R", the desired diagnostic utility name such as "UPD2", and the RETURN key. To see the help message, type "H" and the RETURN key. This message is lengthy and can be aborted by typing the CTRL C command; press "CTRL" and type "C".
- The copy procedure uses the UPD2 utility program. Type "R UPD2" and the RETURN key after the system monitor "." is printed. The system responds with the following printout.

```
.R UPD2.<CR>
UPD2 .BIN
CHUP2B1 XXDP 1 UPB2 UTILITY
RESTART:003710
*
```

- The "*" is the UPD2 program monitor. At this time either return to the system monitor "." from the monitor mode by typing "EXIT" and the RETURN key, or type in the source and destination information for the copy program.

```
*COPY DL1:-DL0:
```

This indicates that the drive 0 (DL0) disk is to be copied onto the drive 1 disk, destroying any data already stored on the drive 1 disk. At this point the system responds with the following.

```
USER DATA ON DL1 WILL BE DESTROYED
PROCEED? (Y/N OR - N)
FILE COPY OR IMAGE COPY? 1 - BLOCK F = FILE
*
```

- At this time ensure that the master disk is in drive 0 and the blank disk is in drive 1. Also verify that commands in step 8 are correct. After verifying that everything is correct, type "F" and the RETURN key.

```
*F <CR>
```

- The process takes approximately 30 minutes. This time varies with the number of files to transfer.
- The master disk is now removed from drive 0 and stored for future reference. The new copy is removed from drive 1 and filed. To copy another disk at this time, insert the master into drive 0 and a blank cartridge disk into drive 1. Repeat the above process, starting at step 7.
- To return to the system monitor "." type the following.

```
*EXIT <CR>
```

The system then prints the "." system prompt character.

DEC/X11

The DEC/X11 software is used primarily to check the reliability of the PDP-11/23-PLUS as an integrated system. The software includes libraries of many separate program modules, each intended for a possible system component. Program modules that apply to the PDP-11/23-PLUS components are selected and chained to produce an interactive system program that exercises the PDP-11/23-PLUS as a complete system. This package is unique to the PDP-11/23-PLUS as shipped. It is called the system run-time exerciser and given the file name EXXXXX.BIN, where XXXXX is the last five alphanumeric characters of the DEC order number. The programs in the run-time exerciser are configured to run continuously rather than to halt on errors, unless a fatal error occurs.

The exerciser sequences through each program module and records any errors that have occurred. When the operator stops the exerciser (by typing the CTRL C command), it prints a summary of the programs run, the number of times they were run (pass count), and the accumulated errors (error count).

The run-time exerciser can be called by its file name under the DLDP—monitor program. It can also be updated when the system is expanded.

The run-time exerciser is started as follows.

1. Load the RL02 diagnostic disk into disk drive 0 and press RESTART. Bootstrap drive 0 by typing "DL0" and the RETURN key.

```
TESTING MEMORY
0256.KW
START? DL0<CR>
```

2. The system responds by printing the name of the DLDP | monitor program. Next enter the date; the system responds with the "." system monitor.

Call the exerciser by typing "R" and the appropriate file name. For example:

```
R FILE NAME< CR>
CHNDLC XXDP—
BOOTED VIA UNIT 0
ENTER DATE (DD-MMM-YY)
```

3. The system prints the run-time exerciser name and status as configured for your specific system. It then prints the following instruction.

```
TO EXERCISE LOAD MEDIUM YOU MUST CLEAR LOC 40.
```

4. At this time, remove the diagnostic disk cartridge from disk drive 0, and insert a blank or "scratch" disk into drives 0 and 1. This is necessary to allow the disk drive system to be exercised without destroying the contents of the diagnostic disk. (A "scratch" disk is one whose contents need not be saved; it should **not** be a previously damaged or scratched disk.)

CAUTION: The contents of both disks are lost when the run-time exerciser is used. Make certain that any disk with programs that must be saved is removed from the system.

5. When the scratch disk is up to operating speed and the unit select (READY) indicator illuminates, press the WRITE PROT button, if necessary, on both drives so that the WRITE PROT indicators on both drives are out.
6. Change the contents of location 40 to 0 as follows.

```
.MOD 40<:CR>  
000040 004000 0<:CR>
```

7. Type "RUN" and the RETURN key after the prompt character.

```
.RUN<:CR>
```

The exerciser now runs until stopped by the operator.

8. To stop the exerciser, type the CTRL C command. (This is done by holding down the CTRL key and striking the C key.) The program stops and prints a run summary.

For explanations of error messages, refer to the *DEC/X11 User's Manual* and the *DECX11 Cross Reference Manual*.

RSX-11M SOFTWARE

The RSX-11M or RSX-11M-PLUS are part of the RSX-11 family and are real-time multiprogramming and multiuse systems for PDP-11/23-PLUS computer systems. They are designed for minimum size and overhead and can be generated to run in a variety of hardware and application environments. Applications range from small, dedicated laboratory or industrial control systems to large, multiuser, transaction-processing and information management systems. The RSX-11M uses high-level languages such as FORTRAN IV, FORTRAN 77, BASIC 11, BASIC PLUS-2, and COBOL.

Monitor Functions

The RSX-11M software performs monitoring functions such as multiprogramming, priority scheduling, task checkpointing, and executive and dynamic memory allocation.

Multiprogramming – This is the concurrent processing of two or more tasks (program images) residing in memory. In the RSX-11 family, multiprogramming is accomplished by logically dividing available memory into a number of named partitions. Tasks are built to execute in a specific partition, and all partitions in the system can operate in parallel.

Event-Driven Priority Scheduling – Task scheduling in the RSX-11 family is primarily event driven, in contrast to systems that use a static scheduling mechanism to determine a task's eligibility to execute. The basis of event-driven task scheduling is the software priority assigned to each active task.

When a significant event (such as I/O completion) occurs, the executive interrupts the executing task and searches for the highest priority task capable of executing.

There is an optional round-robin scheduling capability that ensures that all tasks have equal priority with the CPU.

Task Checkpointing – Once a task is in memory, the executive normally allows it to run to completion in a multiprogrammed fashion even if the task's memory space is required for the execution of a higher priority, nonresident task. However, if it is desirable to free memory for the execution of a higher priority task, a task can be declared checkpointable when created.

A checkpointable task currently active in a partition can be interrupted and swapped out of memory to disk when a higher priority task requests that partition. Later, after the higher priority task has completed its execution, the checkpointed task is rolled in and restored to active execution at the point where it was interrupted.

Dynamic Memory Allocation – As an option in systems with the hardware memory management unit, the RSX-11M executive can dynamically allocate available memory in system-controlled partitions. The executive keeps a list of the available areas in memory and all tasks ready to execute in the partitions. Tasks are brought into memory on a priority basis until all the requests are satisfied or until there is no memory available in the partitions. When a task terminates, the memory it occupies becomes available again.

Executive – The basic executive includes the code that controls the multiprogramming environment, performs task checkpointing and power-fail recovery, and handles system traps.

I/O Services

The file control services allow the user to perform record-oriented and block-oriented I/O operations and to perform additional functions required for file control such as open, close, wait, and delete operations. The file services allow the user to read and write files on file-structured devices and to process files in terms of logical records. Both sequential and direct access modes are supported. Optionally indexed sequential access can be added (RMS-11K).

File System

Files 11 is a general-purpose file system providing a facility for the creation, extension, and deletion of files. Files are normally accessed by the logical file names assigned to them. Many users can have file directories. A scheme for volume and file protection that allows the owner of a volume or file to deny all access or certain kinds of access to all users, groups of users, or particular users in the system is designed into Files 11.

User Interface

The monitor console routine (MCR) is the terminal interface with the user and the RSX-11M or RSX-11M-PLUS operating system. MCR includes: initialization commands, status, messages, task control commands, and system maintenance commands.

Some commands are privileged commands that can be invoked only at privileged terminals, as defined by the system manager. The MCR organization makes it possible for users to add commands to meet special application needs.

RSTS/E AND CTS-500 SOFTWARE

The RSTS/E (Resource Sharing Timesharing System: Extended) and CTS-500 (Commercial Transaction System) are sophisticated, multiuser, timesharing systems. The CTS-500 software system includes all the capabilities of the RSTS/E with the addition of specialized languages and data management software for commercial applications.

The systems' uses include interact timesharing, batch processing, program development, and special purpose applications. With multiterminal services, a number of concurrent terminal users in both local and remote locations can interact with multiterminal application tasks. Tasks can share computational, storage, and input/output services provided by the RSTS/E and CTS-500 systems. With optional software and hardware, either system can be a node in a network of computers using the DECnet DNA architecture. Detailed user information is available in the *RSTS/E Systems User's Guide*.

The systems use industry-standard languages that include BASIC PLUS and MACRO-11 assembly language. The following optional languages are also available: BASIC PLUS-2, COBOL-81, PDP-11 COBOL, DIBOL-11/DECFORM, FORTRAN IV, and FORTRAN 77.

BASIC PLUS-2, COBOL-81, and PDP 11 COBOL require the support of the record management services (RMS) software that is included with all systems. The optional DATATRIEVE-11 data management software also uses RMS. The use of RMS is optional for DIBOL-11, FORTRAN 77 and MACRO-11 assembly language programs. BASIC PLUS and FORTRAN IV do not use RMS.

Both systems consist of a monitor, device drivers, CPUs, and standard software components. Some of the major features include:

- Interactive timesharing environment
- Dynamic allocation of system resources
- User and job privileges
- Batch processing capabilities
- Extensive file processing including file sharing and protection mechanisms
- Terminal handler designed for interactive environments
- Shared common code
- Software-maintained cache of frequently accessed disk data
- Intertask communication
- Disk file and device backup and restore utilities
- System operations and access control utilities
- System maintenance tools
- DIGITAL Command Language (DCL)
- System manager definable terminal commands.

NOTE: The features of the RSTS/E system described below apply to the CTS-500 system as well.

Timesharing

While most users interact with their jobs through terminals, jobs can also run detached (not using a terminal) or with a pseudo keyboard. For example, batch jobs run under the control of other jobs and thus use a pseudo keyboard. A given system's configuration and its particular application and use determines the number of terminals the system can support. System processes and other detached jobs on the system also diminish the number of user jobs.

Dynamic Allocation of System Resources

RSTS/E schedules CPU time and memory residency among jobs based on their priority and processing requirements. Jobs are rescheduled based on time-slicing or as a result of waiting for system services. A round-robin algorithm selects among eligible jobs with the same priority. Job priorities can be altered by the system manager, any privileged user, or a privileged program.

Privilege

As a resource sharing system, RSTS/E gives every user access to all system peripherals and resources unless otherwise restricted by the system manager or other privileged user. A privileged user has full access to all the capabilities allowed by the RSTS/E system and may control the operations of the system such as starting up or shutting down the system, adding or deleting user accounts, designating certain programs as privileged, and controlling the use of system features that make the system operate more efficiently.

Batch Processing

Users can submit batch jobs to perform tasks that require no terminal interaction or to run programs at a later time (outside normal working hours for example). For each batch job, the user can set a limit on the amount of CPU and/or elapsed time allowed and can request error level checking. The system manager starts up and controls batch processors. There can be a maximum of eight batch processors per system. Each batch processor requires a pseudo keyboard and two jobs (one for itself and one for the batch job).

File System

The RSTS/E data file system provides a range of on-line processing capabilities. Disk files can be created, updated, extended, deleted, and renamed under program control; or they can be created, deleted, and renamed using terminal commands. Files can be created and extended dynamically with the RSTS/E file system automatically allocating disk space wherever available. Alternatively, a file can be preallocated to use physically contiguous space. The ability to specify the location of a file on a disk volume also helps to enhance system performance.

Files can be accessed by multiple users simultaneously. When opened for shared update, multiple users can update the same file while it remains open. The file system's block interlock mechanism prevents different users from updating the same part of the file at the same time.

The RSTS/E disk structure consists of a Master File Directory (MFD), User File Directory (UFD), and files. The MFD on each disk can contain up to 1735 UFDs, depending on the size of the MFD. The number of files that a UFD can contain depends on parameters such as the size of the files. Each file is distinguished from other files in that UFD by its unique file name and type.

RSTS/E disk volumes, when used as file-structured devices, are either public or private. The system disk together with any other mounted public volumes constitutes the public structure. All users have access to the public structure. Files cannot span volumes within the public structure. Users have access to mounted private volumes only if their UFDs exist on the private volumes or if the protection codes of the files in other UFDs on those volumes permit access.

Disk volumes can be used as random-access mass storage rather than file-structured devices. Since RSTS/E uses a unique file structure, volumes with disk structures of other operating systems can be used only as nonfile-structured volumes.

Terminal Handling

The RSTS/E terminal handler is designed for interactive environments. It features:

- Full-duplex communications
- Modem control
- Type-ahead with immediate echo
- Programmable echo control
- Multiterminal I/O for individual jobs
- Pseudo keyboard capability.

The echo control allows programs to handle terminal input one file at a time and to retain control of the screen display. This feature gives application programs the capability to use nonblock mode transfer terminals to simulate block mode input. RSTS/E does not support block mode transfer terminals.

The multiterminal service feature allows any job to control multiple terminals, up to the maximum number configured for the system, on a logical channel. This allows one program to control a multitude of terminals that are all performing the same function.

Pseudo keyboards are logical devices that have the logical characteristics of real, physical terminals but have no terminals associated with them. Pseudo keyboards have input and output buffers to which a program can send output, and from which it can receive input. Using a pseudo keyboard as a communications device, a user can write a program to control other jobs. Each RSTS/E system includes at least one pseudo keyboard.

Shared Common Code

RSTS/E allows the sharing of code that is common to multiple jobs. For example, the BASIC PLUS Run Time System is shared by all users of that language. The RMS resident library capability can also be used for those languages and service products using RMS: PDP-11 COBOL, COBOL-81, BASIC PLUS-2, FORTRAN 77, FMS, and EDT. EDT can also be used as a resident library. The code in the resident library must be written in the MACRO-11 Assembler Language. It is recommended that resident libraries be used on systems with greater than 248K bytes (124K words) of memory.

Disk Data Cache

RSTS/E minimizes the need to access a disk by keeping frequently used data in a software-maintained cache. This cache is a specially designated area of system memory space. The data retained in this cache can be restricted to disk directory blocks or it can include data from disk files. In the latter case, a privileged user can allow all disk files or only certain eligible files to be put in cache. As a general rule, disk data files require much more memory dedicated to the cache than do disk directory blocks to obtain system performance gains.

Inter-task Communication

RSTS/E jobs can communicate with each other by sending and/or receiving intertask messages under program control. For example, submission of batch jobs or requesting files to be printed by the line printer spooler uses the message send/receive mechanism.

Jobs can send messages to valid message receivers. A job must have privileges to declare itself as a message receiver. With optional DECnet/E software, the message send/receive mechanism is extended to sending and receiving messages between jobs on different DIGITAL computer systems.

Disk File and Device Backup

RSTS/E allows for total or selective backup of accounts and files to disk. Selective backup can be done on-line. Picking up entire disk volumes can be performed off line for all volumes including the system disk, or it may be performed on line for any volume that is not logically mounted. Since the system disk is always logically mounted, it can only be backed up off-line, or files on it can be backed up selectively on-line.

System Operation Control

The system manager has the ability at system start-up to:

- Add run-time systems
- Set the default run-time system
- Set the default keyboard monitor
- Allocate memory usage
- Install a new RSTS/E executive with different system generation parameters
- Initialize, verify, and correct the file structure of RSTS/E disks.

The system manager and other privileged users have access to many utilities for controlling system operations on-line. The functions they can perform include the following.

- Define normal system startup control files
- Define automatic system restart control files
- Logically mount and dismount disk packs
- Add or remove swap files, run-time systems, and resident libraries
- Add or remove system-dependent commands
- Define terminal characteristics for any terminal
- Change job priorities and other job-related parameters
- Add or delete user accounts and change passwords
- Dump account statistics for all or selected accounts
- Control usage of disk data cache features

System Reliability and Maintenance

The error logging mechanism in RSTS/E records certain classes of hardware errors in a disk file including memory parity and disk errors. The mechanism records system traps that occur in the executive, as well as other events such as system startup and shutdown, and power-fail recovery restarts. The system manager can print the error and analyze it on-line.

If the hardware detects power failure, RSTS/E automatically ceases system operations. When the hardware detects power restoration, RSTS/E automatically reloads the system from the system disk, and reinitializes the system operation by doing a "cold restart". The system resumes operation without operator intervention, but any users previously logged in will be required to log in again. On systems that have MOS memory, the power failure destroys the content of memory unless the hardware battery backup option is installed. Without battery backup the system will have to be manually started.

The system manager can check the reliability of most peripherals on-line by adding a Device Test package. The package exercises the peripherals in an attempt to force errors and identify fault-prone devices.

Software integrity is kept at a high level by using software maintenance tests that allow the system manager to correct software components that are in error. The *RSTS/E Software Dispatch* is a publication which contains articles describing known problems and, where applicable, includes instructions for patching the affected software components.

The automated patching facility (Auto-patch) applies patches by using on-line readable command files, thus avoiding the effort and potential errors associated with keying in patches manually.

User Command Languages

User commands to the RSTS/E system are handled and interpreted by one of the run-time systems capable of acting as a keyboard monitor.

The three standard Keyboard Monitors are BASIC PLUS, RSX, and DCL. All of these interpret sets of system commands, that is, English words followed by optional command parameters. These system commands allow users to perform all the fundamental functions of the RSTS/E system such as logging on and off and running programs.

DIGITAL Command Language (DCL)

The DCL feature is a subset of the DCL implemented VAX/VMS operating system. DCL is implemented as a keyboard monitor and may be used either as the default keyboard monitor or as an additional keyboard monitor. This command set gives the user access to most RSTS/E system features.

Concise Command Language (CCL)

The CCL feature allows each installation's system manager to define additional commands to run system utilities and other user programs. Each CCL command definition specifies the full form of the command and its abbreviation, the program to be run to process the command, and the entire parameters for the program.

CHAPTER 3

INSTALLATION CHECKOUT AND TROUBLESHOOTING

INTRODUCTION

This chapter assists the user in unpacking, installing, maintaining, and troubleshooting the basic PDP-11/23-PLUS system by describing mechanical and electrical hardware checkout procedures as well as the use of diagnostic programs when the basic system is operational. If these procedures do not solve the problem, the user should arrange for equipment servicing. There are several alternative servicing arrangements. Check your warranty and contact your local DIGITAL Field Service representative for information on servicing.

UNPACKING PROCEDURE

The basic PDP-11/23-PLUS system is packaged in two cartons. The smaller carton or "accessory box" contains the system shipping list, three RLO2 disks, cables, and all documentation. Check the shipping lists for proper documentation revision levels and hardware received. Optional units such as VT100, VT102, or LA120 terminals are packaged in additional cartons containing their own unpacking and installation guides.

The following procedures outline the steps required to unpack and inspect a basic PDP-11/23-PLUS system.

1. Cut the nylon retaining straps from around the two shipping cartons and discard them.
2. Remove the accessory box (smaller of the two cartons) from the top of the system. Open and remove the contents. Place the contents on a clean, dry surface area, and check items against shipping lists.
3. Unpack the PDP-11/23-PLUS system as shown in Figure 3-1, steps 1 through 6.

NOTE: Four leveling legs and a stabilizer foot are found in a polybag located between the base of the system and the wooden skid.

4. Slide the ac power cable from underneath the system.

5. Remove the system from the wooden skid.
 - a. Remove the four hex head bolts that secure the shipping blocks to the skid assembly.
 - b. Remove the four shipping blocks at the base of the system.
 - c. Slide and roll the system off the wooden skid. (Use a ramp if available.)

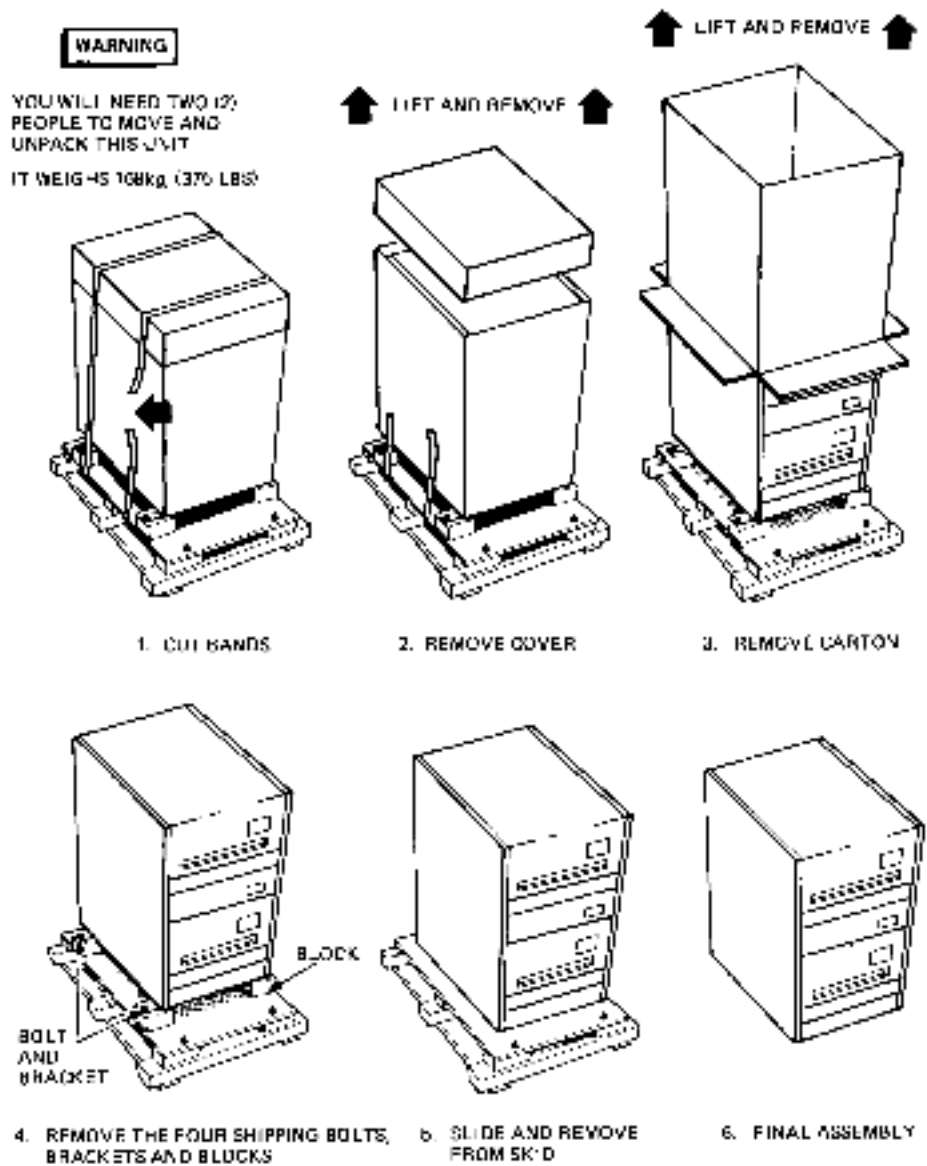

MR 742

Figure 3-1 PDP-11/23-PLUS System Unpacking Instructions

6. Install and adjust the four leveling legs and stabilizer foot as shown in Figure 3-2.
7. Carefully inspect the PDP-11/23-PLUS system for possible shipping damage. Inspect and check the enclosed packing list for lost or missing items. Report any damaged or missing items to the local DIGITAL Field Service or Sales office and to the local carrier.

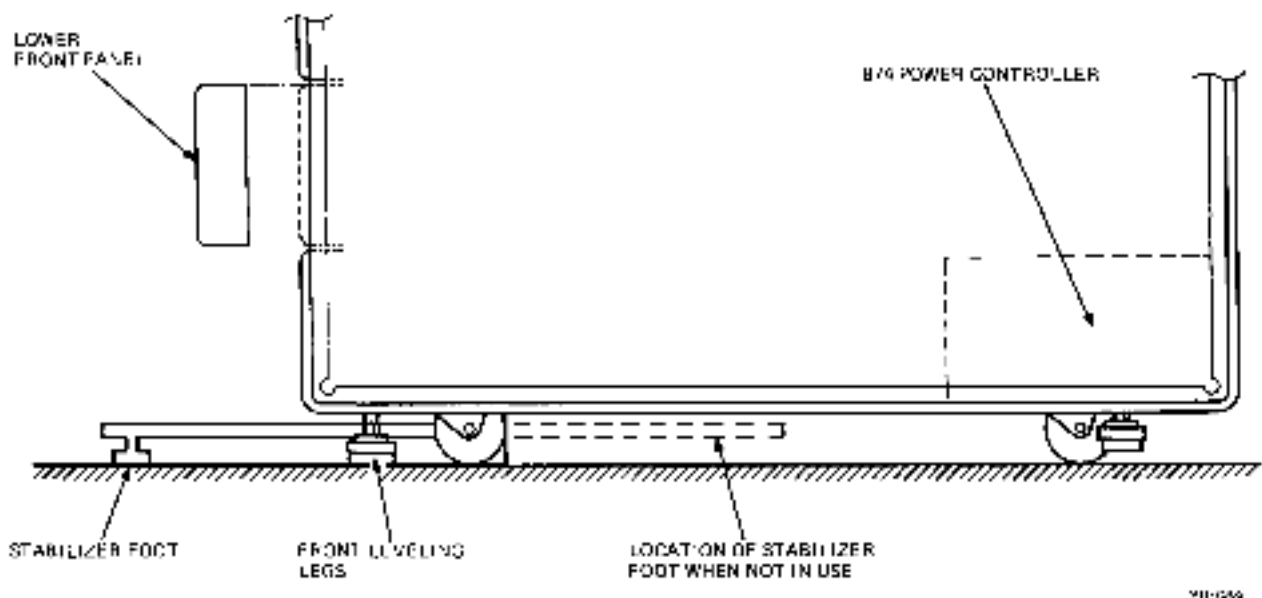

Figure 3-2 Installation of Cabinet Legs and Stabilizer Foot

INSTALLATION CHECKOUT PROCEDURE

The following procedures should be followed to ensure the proper installation checkout of the PDP-11/23-PLUS.

1. Unlock the backpanel using a 5/32 allen wrench. Open the backpanel by swinging it from the right to the left. Remove the backpanel from the system's console by depressing the top spring hinge (top inside of backpanel).
2. Remove the two Phillips head screws from the lower disk shipping bracket located on the left of the drive (Figure 3-3). Check that the lower disk moves easily on its slides and that there is no binding in the cabinet. Ensure that the two RL02 disk drives are adjusted on their mounts an equal distance from each side of the cabinet. The top disk drive shipping brackets should remain in place and be removed only for maintenance.

NOTE: A safety interlock prevents the opening of the RL02 cartridge access cover when power is not available to the drive.

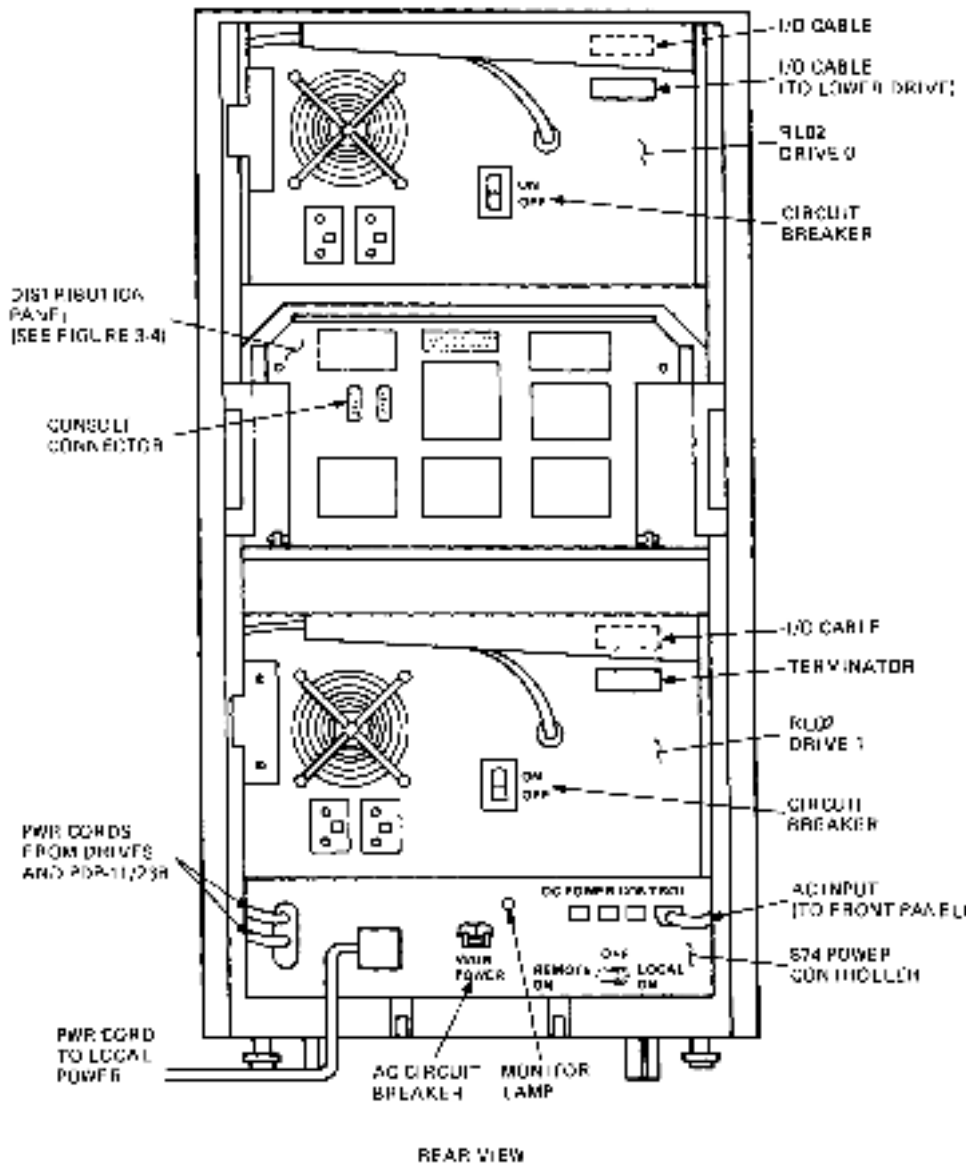

04-2362

Figure 3-3 PDP-11/23-PLUS System (Rear Panel Removed)

3. Check the voltage setting and voltage range selector position, "Low" or "Normal" (NOM), on the back of each RLO2 disk drive, as shown in Figure 3-4. It should be set according to Table 3-1.

WARNING: Be sure that the "Low" position is selected only when the line voltage is below normal and that the ac line voltage at the customer's receptacle is verified by qualified personnel. If the range selector is set to the "Low" position and the line voltage is normal, the performance of the system may be erratic.

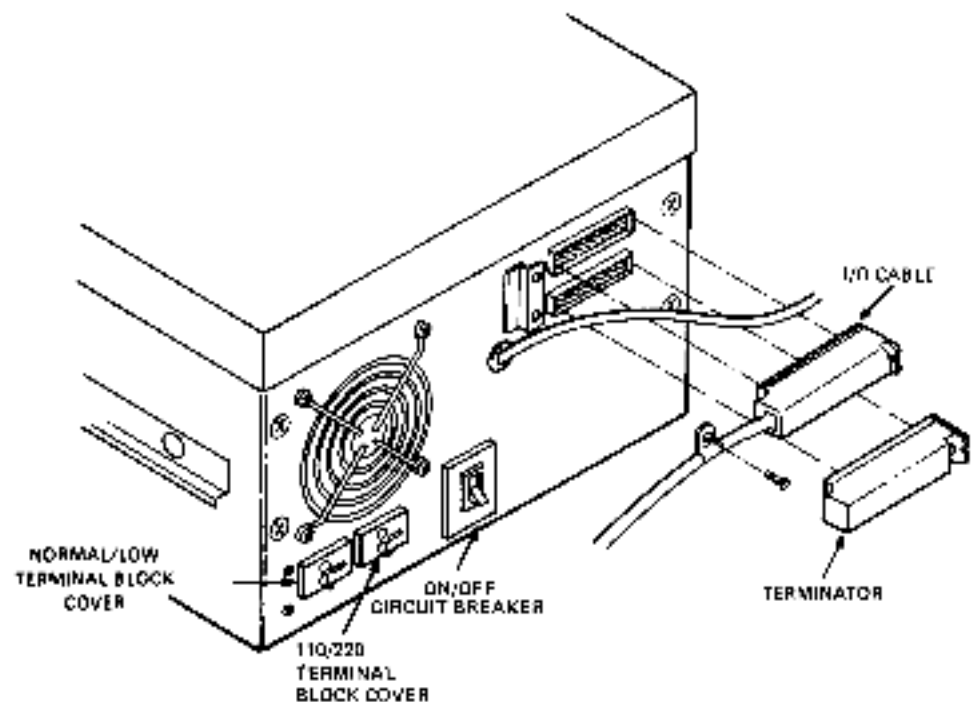

MR-2204

Figure 3-4 RLO2 Lower Disk Drive (Rear View)

Table 3-1 Voltage and Range Selector Setting

| Line Voltage | 110/220 Setting | NORMAL/LOW Setting |
|--------------|-----------------|--------------------|
| 90-105 Vac | 110 | LOW |
| 100-127 Vac | 110 | NOM |
| 180-210 Vac | 220 | LOW |
| 200-254 Vac | 220 | NOM |

For systems operating with low line voltage, proceed as follows.

- a. Remove the two screws from the voltage range selector cover.
- b. Withdraw the cover and reinsert it turned upside down.
- c. After insertion, "Low" must be showing through the small window.
- d. Replace the two screws.

NOTE: Steps 4 through 12 are presented here to verify a factory configured system. In new system installations, omit steps 4 through 12 since all factory shipped systems are operational before shipping.

4. Check that the RLO2 disk drives are properly cabled to the RLV12.

5. Verify that each drive power cord is plugged into the switched ac receptacle J5 on the 874 power controller (Figure 3-5). The circuit breaker at the rear of each drive should be in the ON position (refer to Figure 3-4).
6. Check that the power cord from the PDP-11/23B subsystem is plugged into the switched ac receptacle J4 on the 874 power controller (Figure 3-5).

NOTE: The front of the 874 power controller (Figure 3-5) can be easily viewed by removing the two Phillips head screws on the lower front panel of the system lifting off the front panel (see Figure 3-2).

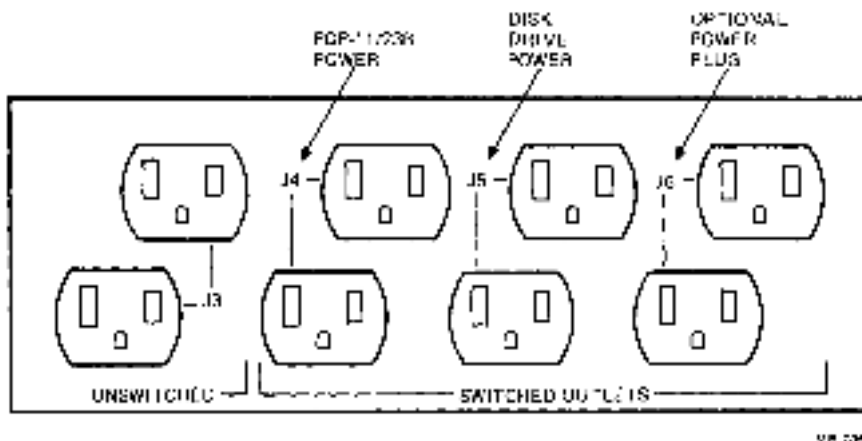

Figure 3-5 874 Power Controller (Front View)

7. Lower the system's distribution panel to its horizontal position by turning the two quarter-turn captive screws located at the top of the panel.
8. Remove the rear cover of the PDP-11/23B subsystem by removing two screws located at the bottom of the rear cover.
9. Ensure that the modules in the PDP-11/23B backplane (Figure 3-6) are securely seated and in the proper position.
10. Check that all ribbon cables from the H349 distribution panel are connected and securely seated on the modules in the PDP-11/23B as shown in Figures 3-6 and 3-7.
11. Verify that the PDP-11/23B voltage select switch is properly configured to either 120 Vac or 240 Vac. Ensure that the circuit breaker on the back of the PDP-11/23B is in the ON position (see Figure 3-6).

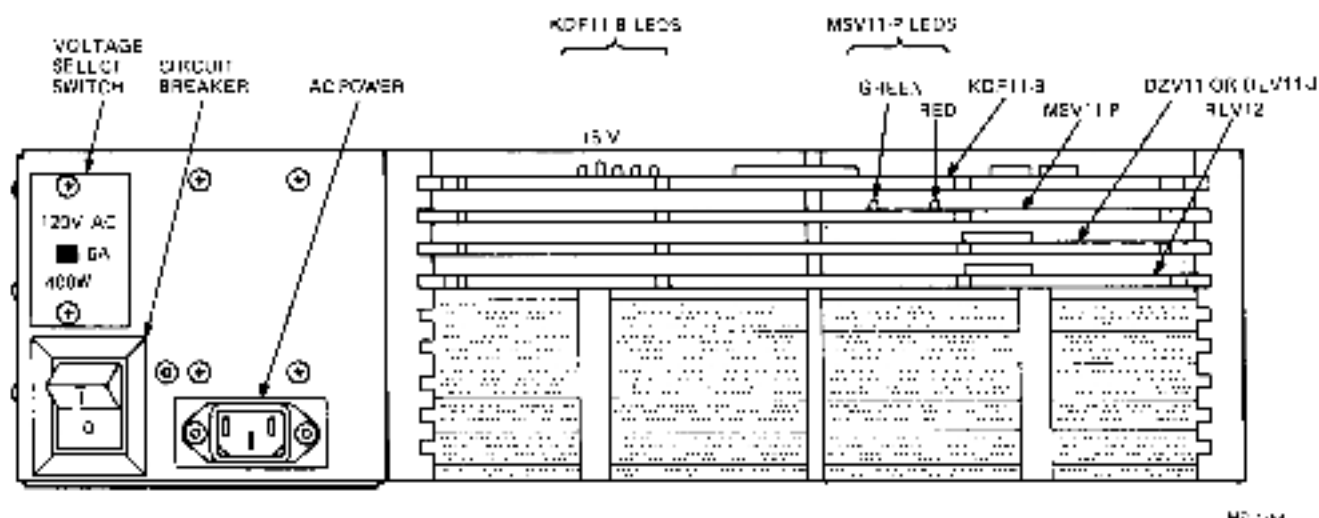

Figure 3-6 PDP-11/23B Subsystem (Rear View)

12. Replace the rear cover on the back of the PDP-11/23B and raise the distribution panel to its normal vertical position.
13. Install the interface cables from the optional units (VT100, VT102, or LA120 terminals) to the system's distribution panel as shown in Figure 3-7.

NOTE: Interface cables must not interfere with the cooling fan on the lower disk drive.

14. Insert the power cables for the optional units into an ac wall outlet.
15. With the circuit breaker on the back of the 874 power controller off (see Figure 3-3) and the Local/Remote switch in the REMOTE position, plug the PDP-11/23-PLUS system cable into the wall outlet. Turn the circuit breaker on.

NOTE: The rear panel should be closed for proper system operation. For maintenance checkout and repair purposes only, the rear panel may remain open for a short period.

16. With the HALT switch on the control panel in the down position (Figure 1-2), apply power using the AUX ON/OFF switch. After 15 seconds, the LOAD indicator on the disk drive (Figure 1-4) illuminates. Open the drive access cover on each drive.
17. Loosen (but do not remove) the head positioner restraining bracket screw (Figure 3-8) on both disk drives. Turn the bracket 90 degrees and retighten the screw.
18. Check that the fan at the rear of each disk drive is operating.

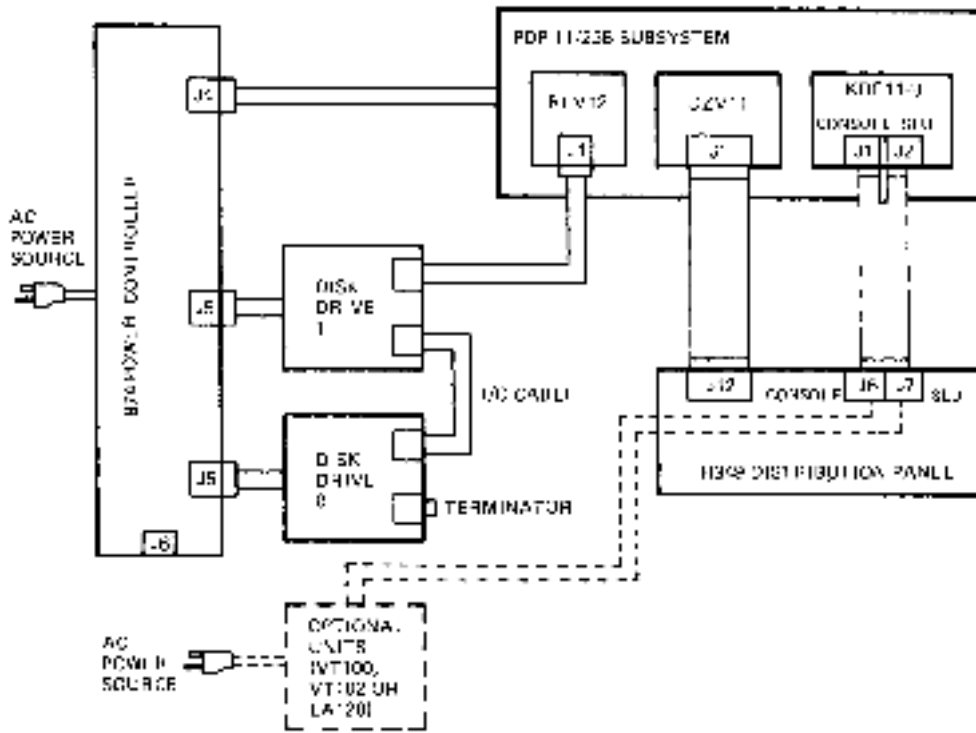

44-1234

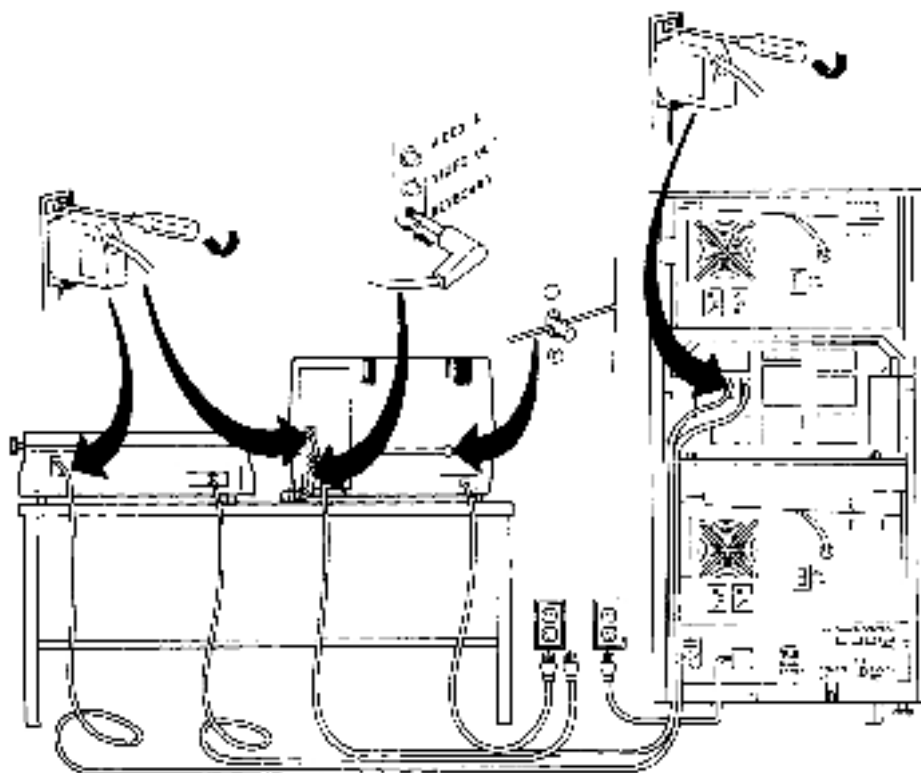

44-1234

Figure 3-7 PDP-11:23-PLUS System Cable Connections

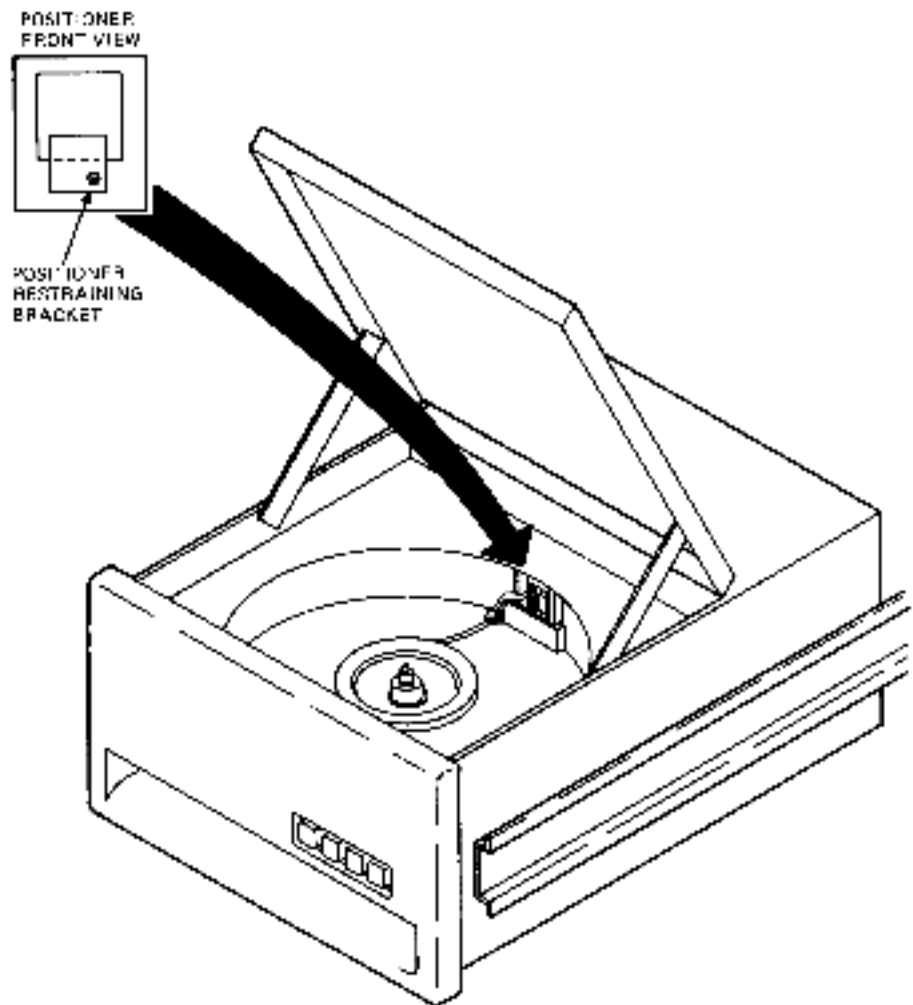

617-2406

Figure 3-6 RLQ2 Head Positioner Restraining Bracket

19. Install the DLDP+ diagnostic disk cartridge with the diagnostic chain program into unit 0 (the top disk drive), and a blank disk cartridge into unit 1 (the bottom disk drive).
20. Check each RLQ2 disk drive for the following.
 - a. The FAULT light indicator is not on.

NOTE: The FAULT indicator may light at this time but should go off as soon as the disk drive is accessed. If it does not go off, consult Figure 3-10.

- b. The WRITE PROT push button cycles off and on.
- c. The LOAD push button cycles off and on.
- d. The top cover cannot be opened when drive power is off, but it can be opened when the drive power is on.

NOTE: If successful completion of the above procedures is not possible, consult the RL02 Disk Subsystem Service Manual for troubleshooting assistance.

21. Check the self-test diagnostics.
 - a. With the HALT switch up, toggle the RESTART switch (Figure 1-2).
 - b. If errors are indicated on the terminal, refer to the troubleshooting procedures in this chapter before continuing with the installation checkout.
22. If no errors are indicated, reset switch E102 (Figure 5-2) on the KDF 11-B (M8189), if necessary, to the user's desired method for bootstrap operation. (Refer to Chapters 5 and 8.)
23. Ensure that the bootstrap is operational. (Refer to Chapters 1 and 2.)
24. Run the system's diagnostics to properly exercise and check out the PDP-11/23-PLUS system. (See Table 3-2.) Refer to Chapter 2 for running the chain diagnostics. Refer to the program listings for running the RLV12/RL02 diagnostics.

Table 3-2 System's Diagnostics

| Program | Title | Number of Passes | Approximate Run Time |
|---------|-------------------------------|------------------|----------------------|
| 11T23B | Chain diagnostics | 1 | 25 min |
| CZRLG | RLV12 controller test part 1 | 2 | 5 min |
| CZRLH | RLV12 controller test part 2 | 2 | 5 min |
| CZRLI | RL02 drive test part 1 | 2 | 10 min |
| CZRLJ | RL02 drive test part 2 | 2 | 10 min |
| CZRLN | RL02 drive test part 3 | 2 | 10 min |
| CZRLK | RL02 performance exerciser | * | * |
| CZRLM | RL02 drive compatibility test | * | * |
| VDZABO | DZV11-1 | * | * |
| VDZBAO | DZV11-2 | * | * |
| CJKBHA | CIS | * | * |

*These tests are lengthy or require operator intervention; refer to program listing for instructions.

TROUBLESHOOTING

The PDP-11/23-PLUS system is fully functional only when all the components of the system are operating properly and are securely interconnected. A malfunction is indicated when the user does not receive the "START?" message after the system is powered up, or the "." prompt character when the disk drives are booted.

The PDP-11/23-PLUS is powered up by setting the HALT switch to the ENABLE (up) position and the AUX ON/OFF switch to the ON (up) position (see Figure 3-9). The system should respond by illuminating the PWR OK indicator and printing (or displaying) the following message on the terminal.

```
TESTING MEMORY
0256.KW
START?
```

If the system fails to respond properly, refer to Figure 3-10, and follow the steps in the troubleshooting flowchart.

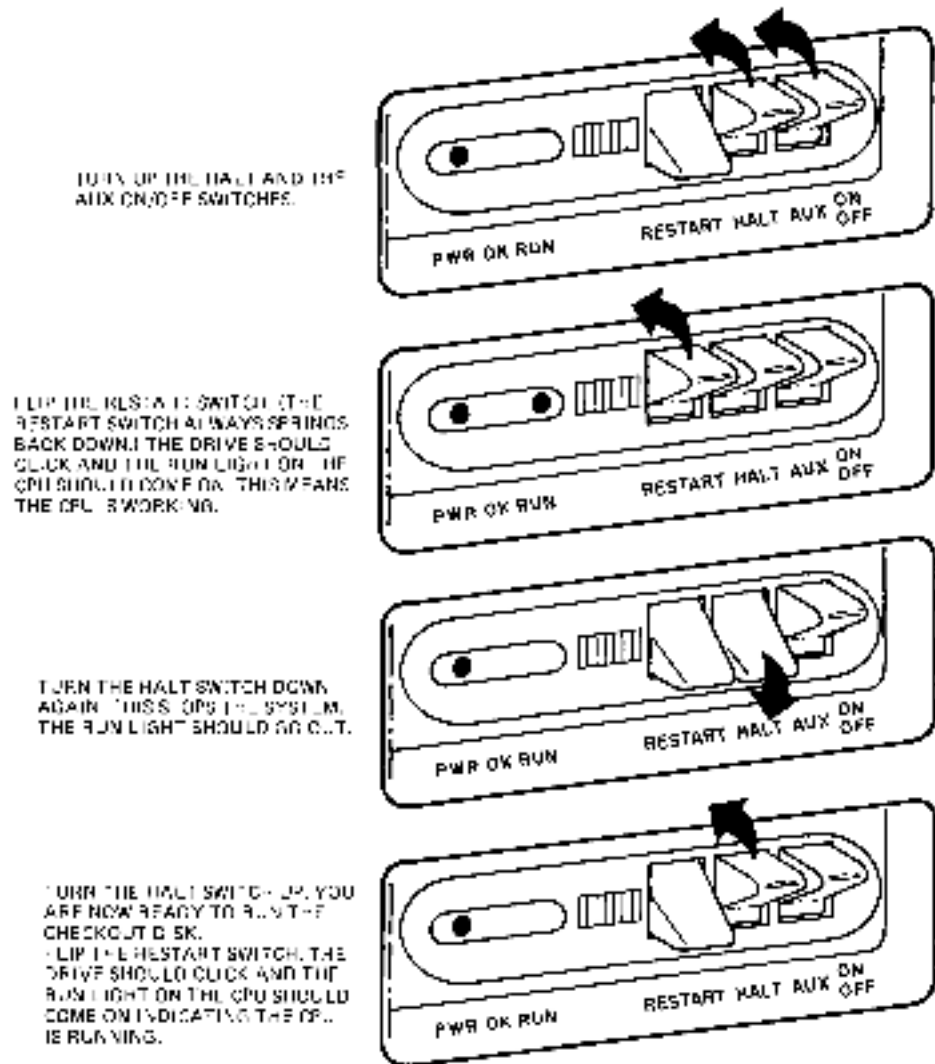

MO-224

Figure 3-9 PDP-11/23-PLUS Control Panel Operation

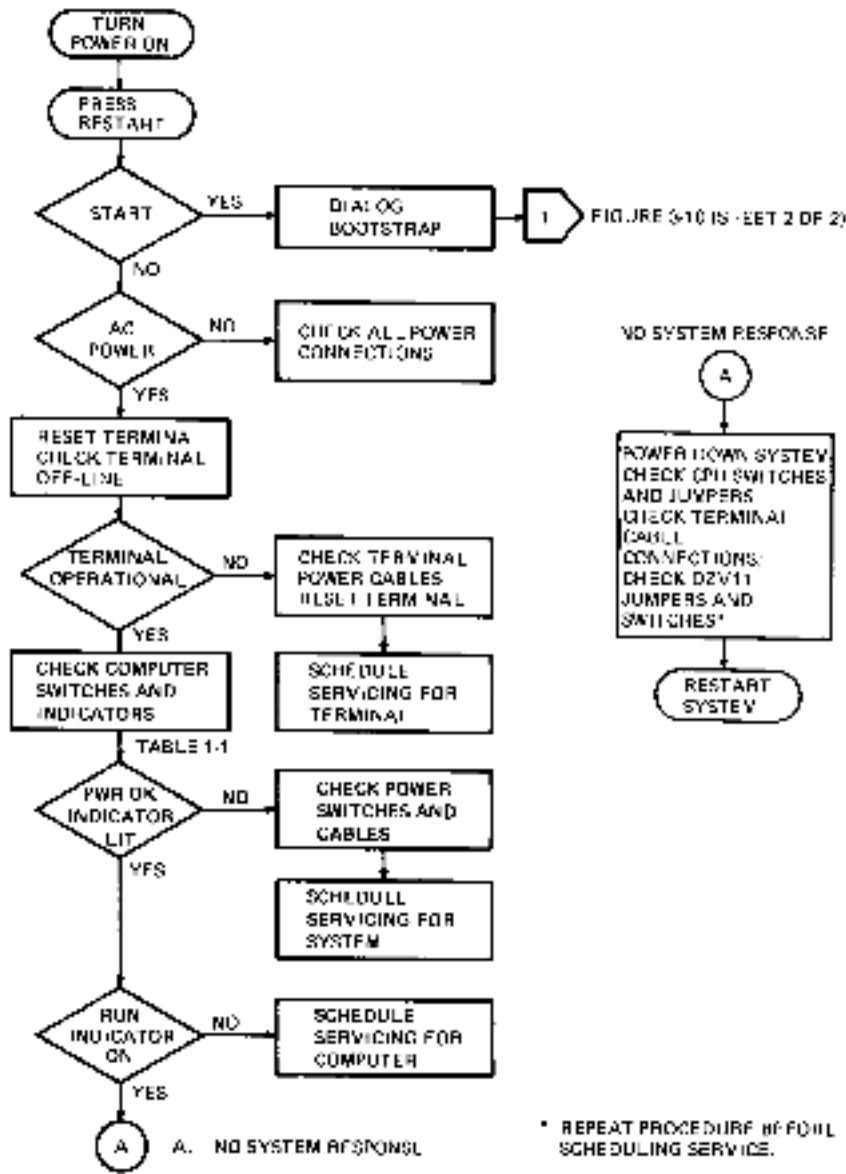

Figure 3-10 PDP-11/23-PLUS Troubleshooting Flowchart (Sheet 1 of 2)

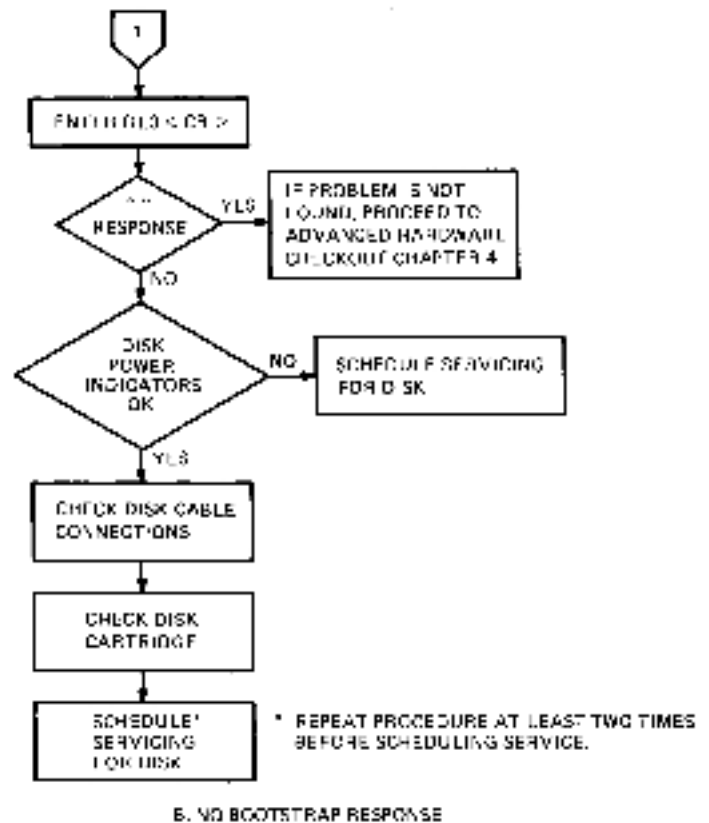

Figure 3-10 PDP-11:20-PLUS Troubleshooting Flowchart (Sheet 2 of 2)

Using the Flowchart

Figure 3-10 is a diagnostic flowchart to assist the user in determining the type of failure that has occurred and the appropriate action to be taken. The system described is the basic configuration. The flowchart should be used as a guide to indicate the problem area. The references in the flowchart indicate paragraphs in this manual that describe the check procedure in detail. These checks are intended to correct some problems; other problems will require servicing by your local DIGITAL Field Service representative.

BOOTSTRAP DIALOG RESPONSE

If the "START?" printout on the terminal occurs, the CPU and memory have been tested and passed. Proceed to the No Prompt After Bootstrapping section in this chapter.

If some other printout occurs or nothing is printed, the system failed to power up properly. The flowchart in Figure 3-10 helps isolate the problem, and the following paragraphs aid in correcting the problem.

AC Power Indications

There are several indications that the power is on once the AUX ON:OFF switch is switched on. After a short time, check the lights on the disk drives and listen for the sound of the cooling fans. If the lights and fans are operating, continue with the troubleshooting flowchart. If no indications of power are present, check the power controller.

874 Power Controller

The 874 power controller is located behind the rear panel at the bottom of the computer cabinet (see Figures 3-2 and 3-3). Open the rear panel and check the following conditions.

1. REMOTE:OFF:LOCAL switch is in REMOTE position.
2. Main ac circuit breaker is in ON (up) position.
3. Monitor lamp is illuminated.
4. Plugs are fully inserted into the outlets located in the front of the 874 power controller (Figure 3-5).

If the circuit breaker is on but the ac monitor lamp is out, try resetting the breaker by switching it off and then on again. If there is still no indication of power, verify that the system power cord is plugged into a live and correctly wired outlet.

Terminal Off-Line Checks

The terminal can be checked while not connected to the computer, or off-line, by switching the terminal to local mode. In this off-line condition, the terminal should operate like an electric typewriter, printing what the operator types. If it does, the problem is likely to be in the computer cabinet; continue with the troubleshooting flowchart. If the terminal does not operate off-line, the problem is in the terminal, and its power should be checked. If the terminal functions off-line, check the baud rate settings.

Terminal Power Cable Connection

The terminal connects to power with a single plug (Figure 3-3). Check that this plug is secure in the ac wall outlet.

Computer Switches and Indicators

The PDP-11/23-PLUS switches and indicators are defined in Table 1-1 and shown in Figure 3-8. Check for the following conditions on the front panel.

1. HALT switch is set to the up position.
2. AUX ON:OFF switch is set to ON.
3. PWR OK indicator is illuminated.
4. RUN indicator is illuminated.

Check the LEDs on the KDF11-B (M8189) microprocessor module. The LED illumination pattern can indicate an error as defined in Table 4-3.

PWR OK Indicator

If the PWR OK indicator on the front panel is not illuminated, check the computer's power. If the PWR OK indicator is illuminated but the RUN indicator is out, the problem is probably in the computer.

Check Power Switches and Power Cable

If the PWR OK indicator does not illuminate when the system power is switched on, check that the circuit breaker on the back of the PDP-11/23B (shown in Figure 3-6) is in the ON position. If the circuit breaker is on and the fuse is good, trace the power cable and verify that it is plugged into the power controller. If the PWR OK indicator still does not illuminate, the system requires servicing.

RUN Indicator ON

When the RESTART switch is pressed, the computer should run until halted. If the computer stops running, it probably failed the internal diagnostics and requires servicing.

Terminal Interface Cabling

The terminal is interfaced to the computer through the console connection located on the system's distribution panel. The KDF11-B microprocessor is connected to the console connector on the distribution panel by a ribbon cable. If this cable works loose during shipping, the terminal will not respond to the computer. Check the cable connection as follows.

1. Switch the AUX ON/OFF switch on the control panel to the OFF position.
2. For PDP-11/23-PLUS systems, refer to Figure 3-6 and locate the KDF11-B (M8189).
3. Check that the cable connector is secure in its socket. This split cable should be connected to J1 and J2 on the KDF11-B and is keyed to fit one way. Check that all modules are seated firmly into the computer backplane.
4. Switch the system power AUX ON/OFF switch back to the ON position.

If the cabling is correct and the problem is not corrected, verify the configuration of the module jumpers. (Refer to Chapter 5.)

NO PROMPT AFTER BOOTSTRAPPING

If the terminal prints the bootstrap dialog when the system power is switched on but fails to respond with the ":" prompt character when DLO or DL1 is entered, the problem is probably in the processor or in a disk drive. Figure 3-10 (Sheet 2) is a flowchart to help isolate the problem to either the computer or a disk drive.

If the ":" character is printed after DLO or DL1 is entered, and the problem is still evident, proceed to Chapter 4 for advanced hardware checkout. If the system prompt is not printed, continue with the troubleshooting flowchart. The remainder of this chapter explains the steps listed in the flowchart.

Disk Drive Power Indications

The LOAD indicators on both disk drives should illuminate when system power is applied. The LOAD indicators will not illuminate if the push button is in the "in" position. If neither indicator illuminates, check the disk drive circuit breaker. Both disk drives have a circuit breaker on the rear of the chassis. Remove the rear panel of the computer cabinet and check the breaker on the failing unit.

If the circuit breaker is not tripped, trace the power cable from the disk drive to the power controller in the bottom of the cabinet (Figure 3-3). Check that the plug is fully inserted in the power outlet.

Check Disk Cable Connections

The disk drives are controlled by an RLV12 (M8061) disk drive controller. The controller connects to the drives as follows.

1. A 40-conductor cable connects to J1 on the RLV12 (M8061) disk controller module. The other end of this cable connects to the lower socket on the top disk drive.
2. From the upper socket on the top disk drive, a second disk I/O cable connects to the system's lower disk drive.

NOTE: On the last disk drive in the system, the I/O cable can connect to either socket. A terminator assembly (70-12293) plugs into the remaining empty socket.

If no loose cables are observed in the disk drive system, check that the modules are firmly seated in the computer backplane.

Check Disk Cartridge

A bad or incorrectly labeled disk cartridge can cause an incorrect response when the disk drive is bootstrapped. Before concluding that the equipment is malfunctioning, make certain the proper disk is in use (the RL02 disks normally have a blue label), and try using another disk.

CAUTION: A sustained tinging, scratching, or rumbling sound (not to be confused with the hissing sound made by the ground brushes riding on the spindle) may indicate head-to-disk contact. If this sound is heard, shut down the drive immediately to avoid damage to the heads. If the heads have "crashed" into the disk, do not use the disk drive again before it is serviced. Do not load a good disk into a disk drive suspected of having had a head crash until the drive has been serviced.

CHAPTER 4 ADVANCED HARDWARE CHECKOUT

INTRODUCTION

When the computer detects a hardware error, it can halt the program and print an error message. Some errors cause the computer to halt any program, while other errors must be detected by using diagnostic programs. An error message may be a number or several words, depending on the program and the error. Such messages help in diagnosing the nature of hardware failures.

When a program halts, the operator can use hardware-implemented routines to examine the conditions under which the error occurred. The operator can halt the program if the computer does not automatically halt it. The operator can also modify maintenance programs to perform specific checks, chain groups of programs together to check larger functional areas, and build exercisers to exercise selected functions. This chapter discusses the on-line debugging technique (ODT), the bootstrap and diagnostic, and the use of DLDP+ and DEC/X11 software.

BOOTSTRAP AND DIAGNOSTIC PROGRAMS

The bootstrap and diagnostic programs are stored in read-only memories (ROMs) on the KDF11-B (M8189) module. One program automatically checks the CPU, another checks the system memory, and a third executes a console test and dialog. These programs are switch selectable (refer to Chapter 5). To use the internal diagnostics, switch E102 on the KDF11-B must be positioned as follows.

| Switch (E102) | Position | Program Selected |
|---------------|----------|-------------------------|
| 1 | ON | CPU test |
| 2 | ON | Memory test |
| 3 | OFF | Turn DECnet boot off |
| 4 | ON | Console test and dialog |
| 5 | OFF | - |
| 6 | OFF | - |
| 7 | ON | RL02 Bootstrap program |
| 8 | OFF | - |

Each time the PDP-11/23-PLUS is switched on or the RESTART switch is toggled, the programs selected by the switches are executed.

The program passes its internal diagnostics when the terminal prints the following.

```
TESTING MEMORY
0256.KW MEMORY
START? DL0
```

At this time the operator enters the commands listed in Table 4-1. DL (or DL0) bootstraps RL02 disk drive unit 0; DL1 bootstraps unit 1.

Table 4-1 Dialog Commands

Command Function

| | |
|-----|--|
| Y | Yes; use the internal switch settings on the KDF11B module to determine the boot device. |
| N | No; halt the processor and enter the ODT program. This enables the operator to examine or modify memory and register locations, as described in the On-line Debugging Technique (ODT) section in this chapter. |
| DLn | RLV12 (RL02) disk bootstrap where n = 0, 1, 2, or 3 for the disk unit select button on the front of the disk drive. If the bootstrap is successfully loaded, the program will respond with the '.' prompt character. |
| DYn | RXV21 (RX02) bootstrap where n = 0 or 1. |

NOTE: If an unrecognized mnemonic or switch setting is encountered, check for the presence of an additional ROM. If present, invoke the ROM boot. If not, the switch checking routine halts, and the dialog routine reprints.

Diagnostic Errors

If one of the programs fails to function properly, the computer prints an error message in the following form.

```
nnnnnn
@
```

The nnnnnn is the address of the error. The @ sign indicates that the computer has halted and control has passed from the program to the console emulator mode, in which the system responds to ODT commands. Check the cause of the error, as listed in Table 4-2.

Table 4-2 List of Error Halts

| Address of Error* | Display (Octal) | Cause of Error |
|-------------------|-----------------|---|
| 173036 | 01 | CP1ERR, R0 contains address of error |
| 173040 | 05 | SLU switch selection incorrect. error in switches |
| 173046 | 05 | SLU error, CSR address for selected device in error. Check CSR for selected device in floating CSR address area. |
| 173200 | 12 | ROM loader error. Checksum on data block. |
| 173232 | 02 | Memory error 2. Write address into itself. Test 0-30 KW with MMU off if present R1 — Address in error and expected data R5 — Failing data |
| 173238 | 01 | CP4ERR, R0 points to cause of error. |
| 173240 | 01 | CP3ERR, R0 contains address of error. |
| 173262 | 02 | Memory error 3. Odd parity pattern (072527) using byte addressing. Failure in this test usually will indicate problem in byte logic. Test 0-30 KW with MMU off if present R1 — Failing address R4 — Expected data R5 — Failing data |
| 173302 | 02 | Memory error in pre-memory data test for Locations 000-776. R2 — Failing data R3 — Expected data R6 — Failing address (000-776) |
| 173316 | 02 | Memory error. Bit 16 set in one of the parity CSRs (772100-772136). Failing memory should have parity error light on. R4 — Address of failing CSR Contents of failing CSR identifies which 1 KW bank of memory caused error. |
| 173364 | 12 | ROM loader error. Checksum on address block. |
| 173376 | 12 | ROM loader error. Jump address is odd. |
| 173526 | 05 | RL01/RL02 device error. |
| 173652 | 05 | AK05 device error. |

*Contents of R7 after halt.

Table 4-2 List of Error Halts (Cont)

| Address of Error* | Display (Octal) | Cause of Error | | | | | | | | | | | | | | | | | | |
|-------------------|-----------------|---|----------------|----------|------------------|-------------|---|-------------------------|--------|---|-----------|--------|---|-----------|--------|---|-------------------------|--------|---|----------------------|
| 173654 | 01 | Switch mode halt. Match was not made with switches. | | | | | | | | | | | | | | | | | | |
| 173660 | 02 | Memory error in 0000-2044 KW 22-bit memory test. This is a common error halt for 6 different tests. If R3 = 0 then error in test 1-5, R4 determines failing test. R4 = Expected data R5 = Failing data <table border="1"> <thead> <tr> <th>Contents of R4</th> <th>Test No.</th> <th>Test Description</th> </tr> </thead> <tbody> <tr> <td>20000-27776</td> <td>1</td> <td>Address test bits 11-00</td> </tr> <tr> <td>177777</td> <td>2</td> <td>Data test</td> </tr> <tr> <td>000000</td> <td>3</td> <td>Data test</td> </tr> <tr> <td>072527</td> <td>4</td> <td>Odd parity pattern test</td> </tr> <tr> <td>125125</td> <td>5</td> <td>Byte addressing test</td> </tr> </tbody> </table> For tests 1-5 (R3 = 0) determine 22-bit failing address as follows: R1 bits 11-00 = failing address bits 11-00 R2 bits 15-06 = failing address bits 21-12 Example: R2 = 123400 R1 = 027776 R2 = 1234XX R1 = XX7776 Ignore the upper 2 octal digits of R1 and the lower 2 octal digits of R2 Failing 22-bit address = 12347776 Errors in address uniqueness test. Test checks address bits 21-06. Test No. 6. If R3 is not equal to 0 then error is in this test. R4 = Expected data R5 = Failing data R2 = 22 bit failing physical address bits 21-06 Failing address bits 06-00 are always 0. Example: R2 = 024566 Failing address = 02456600 | Contents of R4 | Test No. | Test Description | 20000-27776 | 1 | Address test bits 11-00 | 177777 | 2 | Data test | 000000 | 3 | Data test | 072527 | 4 | Odd parity pattern test | 125125 | 5 | Byte addressing test |
| Contents of R4 | Test No. | Test Description | | | | | | | | | | | | | | | | | | |
| 20000-27776 | 1 | Address test bits 11-00 | | | | | | | | | | | | | | | | | | |
| 177777 | 2 | Data test | | | | | | | | | | | | | | | | | | |
| 000000 | 3 | Data test | | | | | | | | | | | | | | | | | | |
| 072527 | 4 | Odd parity pattern test | | | | | | | | | | | | | | | | | | |
| 125125 | 5 | Byte addressing test | | | | | | | | | | | | | | | | | | |
| 173664 | 02 | Memory error in preliminary address test for locations 000-776. R2 = Failing data R5 = Failing address and expected data | | | | | | | | | | | | | | | | | | |
| 173670 | 01 | Error CPU test 9. JSR R3 failed. | | | | | | | | | | | | | | | | | | |
| 173700 | 01 | Error CPU test 9. JSR PC failed. | | | | | | | | | | | | | | | | | | |

*Contents of R7 after halt.

Table 4-2 List of Error Halts (Cont)

| Address of Error* | Display (Octal) | Cause of Error |
|-------------------|-----------------|---|
| 173704 | 05 | RX01/RX02 device error. |
| 173714 | 04 | In console terminal test a "NO" typed. |
| 173738 | 02 | Memory error 1. Data test failed. Test 00-30 KW with MMU off if present. R1 — Failing address R4 — Expected data (either 0 or 177777) R5 — Failing data |
| 173740 | 01 | Error CPU test 9. "RTS" return failed. |
| 173742 | 03:04 | Console terminal test. No done flag |
| 173760 | 06 | TU68 error halt. |

*Contents of R7 after halt.

If there is no printout, check the diagnostic lights on the KDF11-B (M8189 module) to determine the failure. Refer to Figure 4-1 and Table 4-3.

Serial Line Unit Error — If the error message points to the serial line unit, check switch E114 on the KDF11-B module (Figure 5-3 and Table 5-4), and ensure that the terminal is configured correctly. Refer to Chapter 5.

CPU, Memory, or ROM Error — Arrange for equipment servicing.

Disk Bootstrap Errors — If the error message points to the disk, refer to the troubleshooting procedure in Chapter 3 to isolate a possible power or cabling problem.

The control status register (CSR) for the system can be examined by using the ODT command as follows.

```
@R3:nnnn<CR>
```

R3 contains the contents of the control status register. If the drive error bit is set in R3, the drive status can be examined in R5 as follows.

```
@R5:nnnn<CR>
```

After examining the registers, the RLV12 bootstrap can be restarted with the RESTART switch.

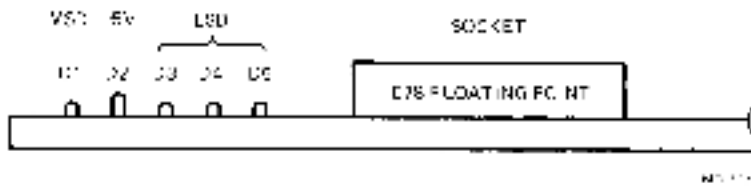

Figure 4-1 KDF11-B Diagnostic LED Display

Table 4-3 Diagnostic LED Error Display*

| Display (Octal) LED | MSD | | LSD | | Type of Error |
|---------------------------|-------------|-------------|-------------|-------------|---|
| | Bit 3 D1 | Bit 2 D3 | Bit 1 D4 | Bit 0 D5 | |
| 01 | OFF | OFF | OFF | ON | CPU test error. |
| 02 | OFF | OFF | ON | OFF | Memory test error. |
| 03 | OFF | OFF | ON | ON | Waiting for console terminal transmitter ready flag. |
| 04 | OFF | ON | OFF | OFF | Waiting for console terminal receiver done flag. |
| 06 | OFF | ON | OFF | ON | Load device status error. |
| 08 | OFF | ON | ON | OFF | Bootstrap code incorrect. |
| 07 | OFF | ON | ON | ON | DECnet waiting for response from host. |
| 10 | OFF | ON | ON | ON | DECnet waiting for message completion. |
| 11 | ON | OFF | OFF | ON | DECnet processing received message. |
| 12 | ON | OFF | ON | OFF | ROM bootstrap error (not used on KDF11-B). |
| 13 | ON | OFF | ON | ON | Special memory test failure on locations 0-8 (Can occur when memory test disabled.) |
| 17 | ON | ON | ON | ON | System hung, HALT switch on, or not power-up mode 2. |

*The light pattern indicates the corresponding test is in progress or failed. Some test retry (DECnet) and others will halt the CPU (CPU, memory non-DECnet boots).

Trap Vector – If the program halts in the trap vector area (location 0-100), a time-out trap returns the program to the dialog routine. Check for an unrecognized mnemonic and refer to the troubleshooting procedure in Chapter 3. If the problem cannot be isolated, schedule the system for servicing.

ON-LINE DEBUGGING TECHNIQUE (ODT)

The on-line debugging technique (ODT) is the most basic way of communicating with the computer. It consists of a group of commands and routines for locating error conditions and for simple communication with the computer.

The hardware-implemented ODT commands are a subset of the commands in a larger software-implemented ODT program. The hardware ODT program serves primarily for hardware-oriented diagnosis of problems. The computer responses to ODT commands help to trace events occurring in the computer. The hardware-implemented ODT resides on the KDF 11-B module.

CAUTION: The hardware ODT can alter programs; therefore, the master disks should be copied and set aside before using ODT. Chapter 2 presents instructions for copying disks.

The ODT functions only when the computer is in the console emulator mode. This mode of operation is used instead of switches and lights on a console panel to communicate directly with the computer. The operator types commands on the keyboard, and the computer prints responses on the terminal instead of lighting lamps on a computer console. The computer enters the console emulator mode by any of the following methods.

1. The operator presses the **BREAK** key (when this key is configured to halt the processor).
2. The program executes a **HALT** instruction.
3. The computer detects an error condition.
4. The operator presses the **HALT** switch on the front panel.

When the computer halts the program and enters the console emulator mode, the system prints the following.

```
nnnnnn
@
```

The number nnnnnn is the octal location of the next instruction to be executed, and the @ is the ODT prompt character. At this point the operator may examine or alter the contents of the computer registers and memory by typing ODT commands. The use of ODT commands is explained in the *Microcomputer and Memories Handbook*.

TROUBLESHOOTING WITH DLDP+

The DLDP+ diagnostics help to isolate failures by testing functions on a pass/fail basis. Some programs can be modified to perform specific functions within the more general functions they test. Using DLDP— programs beyond the pass/fail level requires careful study of the program listings and the *XXDP ; /SUPR User's Manual*.

The user's manual describes the commands available under the various DLDP— utility programs, listing specific program modifications and procedures. This section describes some of the more common operations. For more comprehensive instructions, refer to the program listings and the *XXDP ; /SUPR User's Manual*.

Error Messages

DLDP+ programs do not use a universal format for error printouts. The large number of parameters tested requires a variety of formats. Most formats print several octal words giving the parameters at the time of the error plus a mnemonic indicating what happened. This mnemonic can be found in a table or error directory in the listing. The meanings of these mnemonics are usually program-specific and therefore are not discussed here.

Restarting Programs

Diagnostic programs can be configured to run continuously, halt at the end of a pass, and/or halt (or loop) on selected errors. The operator can halt a program by pressing the BREAK key (if enabled to halt the processor) or by pressing the HALT switch. The BREAK command causes the computer to enter the console emulator mode and print the @ prompt character. The operator can then enter ODT commands or restart the diagnostic program by typing the restart address given in the program listing. For example:

```
@2006
```

If the diagnostic program has not overwritten the memory locations of the DLDP+ monitor program, the operator can restart the monitor by typing the restart address that was printed in the monitor heading when the disk was bootstrapped. If the diagnostic program did overwrite the memory (a memory exerciser, for example), the disk must be rebooted to return to the DLDP— monitor.

Modifying a Diagnostic Program

Diagnostic programs can be modified to perform specialized diagnostic functions. The program listings explain what to modify for each purpose. The modification process requires the ODT program to change the contents of certain locations. For example, assume the memory exerciser

program must be altered to perform a long loop instead of a short loop. The program listing directs the user to change software switch register 176 to 1000. This can be done as follows.

1. Load the program with the L command instead of the R command.

```
.L ZKMAD0<:CH>
```

The computer loads the program into memory and returns the "." prompt character. The program is not executed at this time.

2. Press the BREAK key on the terminal, or use the HALT switch on the processor. This places the computer into the console emulator mode and gives control to the ODT program. The system responds by printing the @ prompt character.
3. Open location 176 by typing 176 and the slash command. The computer responds by printing the present contents of that location.

```
@176:000000
```

4. After the zeros printed by the computer, type the number specified by the program listing.

```
@176:000000 1000<:CH>
```

```
@
```

5. Verify that the change has been made by typing the 176: again and examining what is printed. If the contents are correct, strike the carriage return.

```
@176:001000<:CR>
```

```
@
```

6. Start the program at location 200 with the ODT GO command.

```
@200G
```

7. The computer prints the program name and executes the program. When testing is complete, the system prints END PASS and begins another pass.
8. To terminate the program, press the BREAK key or HALT switch. This returns control to the ODT program. To return to the DLDP+ monitor program, place the HALT switch up and press RESTART.

Modifying the program by this method affects only the computer memory not the program on the disk. Therefore, it is unnecessary to change the location back after finishing the program.

For further explanation of ODT commands, refer to the *Microcomputer and Memories Handbook*.

Single Instruction Execution

ODT can execute a program a single step at a time. To do this, load the program with the L command instead of the R command. Place the HALT switch down. Enter the starting address (or a desired address for the first instruction to be executed) as described for normal program execution. The G command initializes the system; thereafter, the program can be executed one instruction at a time by repeatedly pressing P (Proceed) on the terminal. An example of single word instruction execution is shown below.

```
@2000
000202
@P
000204
@P
000206
@P
```

Note that after executing each instruction, the processor halts and prints the address of the next instruction. Thus, branch, jump, and skip instructions will alter the program counter (PC) as required in normal program execution, allowing the operator time to observe program and hardware operation.

Expanding the Diagnostic Chain

The diagnostic chain file configured for the PDP-11/23-PLUS system can be expanded to include diagnostics for add on options. An example is presented here for expanding the chain to include a diagnostic program that tests an LA 180 printer option. For details on the use and meaning of the commands shown, refer to the *XXDP ; /SUPR User's Manual*. Boot the system and get the "." system monitor as described in Chapter 2.

1. Load the text editor program.

```
.R XTECO<CR>
XTECO.BIN
```

The system prints the program heading.

```
C HUTE81 XXDP - XTECO UTILITY
RESTART:005128
```

2. Enter the name of the disk on which the file will be built, the file name, and the CCC chain extension.

```
*TECO DL1:11T23LB CCC<CR>
```

The system responds as follows.

```
MAKE OUTPUT READY. TYPE <CR> WHEN READY.
```

At this point press the WRITE PROT button on disk drive 1 so that the WRITE PROT indicator is not illuminated. Then type a carriage return.

```
<CR>
```

3. Next, expand the existing chain file space by typing

```
A<ESC>A<ESC>A<ESC><ESC>
```

after the asterisk. This is echoed by the system.

```
*ASA$$$
```

ESC is the escape key on the terminal. On some terminals it is labeled ALT MODE. The escape command is echoed as a S on the printout. One ESC separates commands; two ESCs terminate a command.

4. The new program should be inserted after the existing programs. To reach that point in the existing file, type 27LT<ESC><ESC> after the asterisk. This is echoed by the system as follows.

```
*?7LT$$
```

5. Insert the LA180 diagnostic. Enter the program name and diagnostic number. For example:

```
*I;LA180 PHINTER TEST (MAINDEC 11 DZLAE B D)<CR>
```

```
R ZLAEB0<CR>
```

```
<ESC><ESC>
```

```
*
```

6. Exit from the program by pressing EX<ESC><ESC>, and then the EXIT and the RETURN keys. The commands are echoed.

```
*EX$$  
EXIT<CR>
```

The chain file can be run under the DLDP+ system monitor as follows. The "C" is interpreted as an "R" for running chain programs (see HELP MESSAGE).

```
.11T23B<CR>
```

For further information about building and editing files, refer to Chapter 4 of the *XXDP+/SUPR User's Manual*.

TROUBLESHOOTING WITH DEC/X11

When the DEC/X11 system run-time exerciser detects an error, it prints an error message describing the circumstances of the failure. In analyzing the message, first determine what system component was involved in the error. Then either run the appropriate DLDP+ diagnostic or analyze the error message further. Next look up the error call in the program listing to see what operation was in progress when the error occurred. Finally, examine the parameters of the failure (program counter, processor status word, stack pointer, etc.).

Program modules can be modified to halt on different errors, provide different printouts, and run alone or with selected other programs. ODT can be used to examine processor registers and memory locations. Such detailed analysis requires extensive knowledge of DEC/X11 commands and the computer hardware. Chapters 5 through 9 of the *DEC/X11 User's Manual* and *DEC/X11 Cross Reference Manual* explain commands, errors, and techniques. The two-volume Microcomputer Handbook series describes the computer hardware, peripherals, and memory options. This manual discusses fault isolation to the system component level.

Error Messages

There are three basic types of error printouts from the run-time exerciser: system errors, data errors, and status errors.

The System Error Printout – DEC/X11 prints a system error message whenever it detects one of the following.

1. A bus error trap (to location 4)
2. A reserved instruction trap (to location 10)
3. A queue overflow

A system error printout can be recognized by the mnemonic SYS ERR. If a system error occurs, run the program modules individually. If all modules pass when they are run alone, run them in groups until the failure returns. Refer to the **Selecting and Deselecting Program Modules** section in this chapter for instructions on selecting individual program modules.

The Data Error Printout - The program modules report data errors by means of a printout in the format

```
RLAAG PC XXXXXX APC YYYYYY PASS# NNNNN. ERR# NNNNN. DATA
ERROR
CSRA AAAAAA S/B BBBBBB WAS WWWWWW WRADR DDDDDD ROADR
EEEEEE
```

where:

RLAAG is the name of the failing module.

PC XXXXXX is the physical address of the program call that causes the printout (program counter).

APC YYYYYY is the assembled program count of the program call.

PASS# NNNNN. is the pass number (decimal) during which the error occurred.

ERR# NNNNN. is the error count (decimal) for the current run.

CSRA AAAAAA is the address of the control and status register of the failing device.

S/B BBBBBB is the expected data ("should be" data).

WAS WWWWWW is the actual data (bad data).

WRADR DDDDDD is the address of the expected data.

ROADR EEEEE is the address of the bad data.

The printout can be recognized as a data error printout, because the first line ends with the words DATA ERROR. The first line starts with the name of the program test module. This can be referenced in the module abstracts. Table 4-4 lists DEC/X11 module names for the basic PDP-11/23-PLUS and the corresponding DLDP + diagnostics. The user can rerun the DEC/X11 modules individually, or run the applicable DLDP— program. If the DEC/X11 error printout is to be examined further, the APC value can be found in the program listing. The location printed for the APC contains the program call that caused the error printout.

The Status Error Printout - This printout is in the same general format as the data error printout. It can be recognized as a status error by the absence of the terms SYS ERR or DATA ERROR in the first line. It does not contain the S/B (should be) or WAS printouts, but instead includes a STATC value. This value is the contents of the status register of the failing device. Like the data error, the status error also can be traced to the listing by looking up the location given for the APC.

Table 4-4 DEC/X11-DLDP+ Program Cross Reference

| DEC/X11 Test Module | PDP-11/23-PLUS Function/ Component Tested | Applicable DLDP – Diagnostic Program |
|---------------------------|--|---|
| CPAF | Processor instruction set | CJKDBD.BIC |
| - | Processor MMU | CJKDAD.BIN |
| CPBG | Processor boot/ROM | CVMHAE.BIN |
| - | Processor SLUs | CJDLAA.BIN* |
| - | Processor SLUs and line clock | CJKDHA.BIN |
| - | MOS/CORE memory exerciser | CVMSAA |
| - | Processor floating point instruction set | CJKDC.BIN CJKDD.BIN |
| - | DZV11 | CXDZBCO |
| RLAA | Disk drive system | |
| | RLV12 diskless test | CIRLAA.BIC |
| | RLV12 controller test part 1 | CVRLBA |
| | RLV12 controller test part 2 | ZRLB |
| | RL02 drive test part 1 | ZRLC |
| | RL02 drive test part 2 | ZRLD |
| | RL02 performance exerciser | ZRLE |
| | RL02 drive compatibility test | ZRLF |
| DLAH | (DLV11-J) serial line interface | VOLA |
| | *Also checks a DLV11-J | |

Selecting and Deselecting Program Modules

When troubleshooting the PDP-11/23 PLUS, the user may find it useful to delete a failing program module or to delete all modules except one or two that are failing. This can be accomplished by using the select and deselect commands. The user can deselect program modules one at a time or deselect all modules and then select just those that are desired. The commands function as follows.

- .SEL <CR> This command selects all modules for execution.
- .SEL RLAA0 <CR> This command selects only the RLAA0 program. The program name must be typed as it appears in the listing.
- .DES <CR> This command deselects all modules.

`.DES RLAA0 <CR>` This command deselects only the RLAA0 module.

NOTE: *The select and deselect commands operate only within the system exerciser program. They cannot be executed without first starting the exerciser.*

The status of a module (selected or deselected) can be obtained using the MAP command. This command instructs the monitor program to type a list of the resident modules with their starting addresses and status. For example:

```
.MAP < CR>

CPAFO AT 017752 STAT 040020
CPBG0 AT 021502 STAT 040020
RLAA0 AT 023242 STAT 150000
```

The second most significant octal digit of the STAT (status) printout indicates whether or not a module is selected. If the number is a 0, 1, 2, or 3 the module is deselected; if it is a 4, 5, 6, or 7 the module is selected. Bit definitions for the entire number are presented in Chapter 5 of the *DEC/X11 User's Manual* and *DEC/X11 Cross Reference Manual*.

Expanding the Run-Time Exerciser

The run-time exerciser for each system has a unique configuration. If the system is expanded, a new exerciser must be built. Because the exerciser is an interactive system of programs, the user must rebuild it rather than simply add to it. This involves selecting the program modules appropriate to the new hardware and including them with the existing program modules in a new exerciser. The user should refer to the *DEC/X11 User's Manual* and *DEC/X11 Cross Reference Manual* for detailed explanations of the steps and possible error messages.

CHAPTER 5 SYSTEM COMPONENTS

INTRODUCTION

The PDP-11/23-PLUS system contains a PDP-11/23B processor subsystem and two RL02 disks installed in a free-standing console. The system features a distribution panel (located in the rear of the system) that provides for convenient interfacing with peripheral equipment. The PDP-11/23-PLUS becomes a complete and operational computer system when connected to a terminal. DIGITAL offers a selection of terminals that interface with the PDP-11/23-PLUS.

PDP-11/23-PLUS MODELS

The PDP-11/23-PLUS is available in a number of configurations that operate at 120 Vac or 240 Vac with 256 or 512K bytes of memory. The components for the various configurations are listed in Table 5-1. Optional system components are presented in Chapter 6.

PDP-11/23B PROCESSOR SUBSYSTEM

The PDP-11/23-PLUS contains a PDP-11/23B processor subsystem. This subsystem (Figure 5-1) consists of a BA11-S mounting box that houses a power supply, a logic assembly, and an ac input box. The BA11-S is available with a control panel equipped with operating switches and indicators or with a blank front panel used for system expansion.

The logic assembly includes a card frame, two cooling fans, and a H9276 backplane. This 9 × 4 backplane accepts the three quad-height modules used in the basic PDP-11/23-PLUS system, leaving six additional empty slots for system expansion.

The basic processor subsystem consists of a KDF11-B microprocessor, a MSV11-PK (256K bytes) or MSV11-PL (512K bytes) memory module, a DZV11* asynchronous multiplexer module (commercial systems only), and a RLV12 disk controller module. The location of these modules in an H9276 backplane are shown in Figure 5-2.

*Or other communication options such as a DLV11-J.

Table 6-1 PDP-11/23-PLUS System Components

| | PDP-11/23 | | | | | | | |
|---------------------------|-----------|-----|-----|-----|-----|-----|-----|-----|
| | BH | BJ | BK | BL | BM | BN | BP | BR |
| Operating Voltages | 120 | 240 | 120 | 240 | 120 | 240 | 120 | 240 |
| Memory Size (Kb) | 256 | 256 | 512 | 512 | 256 | 256 | 512 | 512 |
| PDP-11/23 Box | BC | BD | BE | BF | BC | BJ | BK | BF |
| KDF 11-B M8189 | 1 | 1 | 1 | 1 | 1 | 1 | 1 | 1 |
| KEF 11-BA CTS* | - | - | - | - | 1 | 1 | 1 | 1 |
| KTF 11-AA MMU | 1 | 1 | 1 | 1 | 1 | 1 | 1 | 1 |
| MSV 11 M8067 | PK | PK | PL | PL | PK | PK | PL | PL |
| RLV 12 M8061 | 1 | 1 | 1 | 1 | 1 | 1 | 1 | 1 |
| BC80M-6 Cable | 1 | 1 | 1 | 1 | 1 | 1 | 1 | 1 |
| DZV 11-C M7957* | - | - | - | - | 1 | 1 | 1 | 1 |
| BA 11-Mounting Box | SA | SB | SA | SB | SA | SB | SA | SB |
| H403B AC Input Box | 1 | 1 | 1 | 1 | 1 | 1 | 1 | 1 |
| H7851 Power Supply | 1 | 1 | 1 | 1 | 1 | 1 | 1 | 1 |
| H9276 Backplane | 1 | 1 | 1 | 1 | 1 | 1 | 1 | 1 |
| H9642 Console Cabinet | AA | AA | AA | AA | AA | AA | AA | AA |
| B74 Power Controller | A | B | A | A | A | B | A | A |
| HS49 Distribution Panel | 1 | 1 | 1 | 1 | 1 | 1 | 1 | 1 |
| 7018281 Cable to KDF 11-B | 1 | 1 | 1 | 1 | 1 | 1 | 1 | 1 |
| 7018219 Cable to DZV 11-C | 1 | 1 | 1 | 1 | 1 | 1 | 1 | 1 |
| RL02-FK | 2 | 2 | 2 | 2 | 2 | 2 | 2 | 2 |
| BC21Z-8 | 1 | 1 | 1 | 1 | 1 | 1 | 1 | 1 |

*Options available

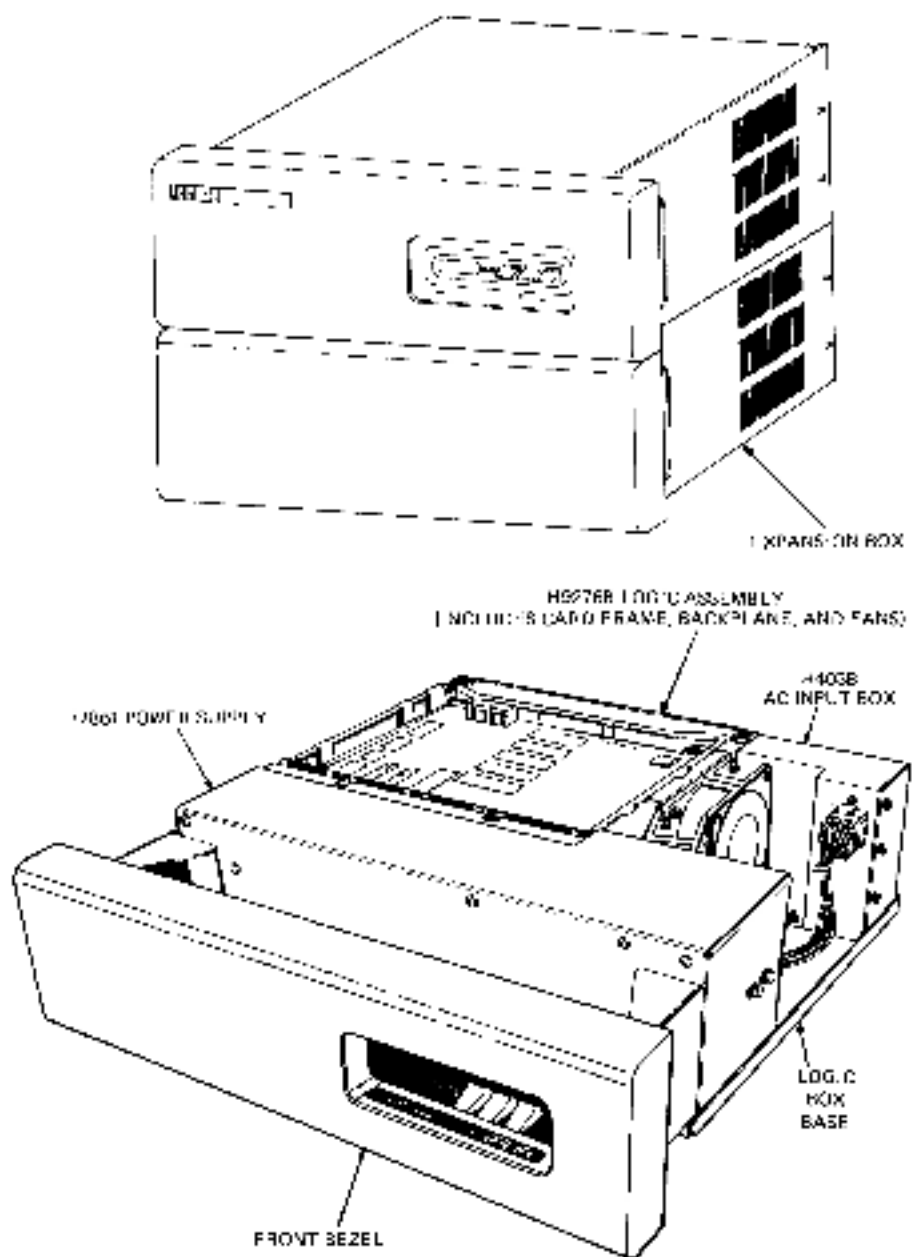

6-1 2102

Figure 5-1 PDP-11/23B Subsystem

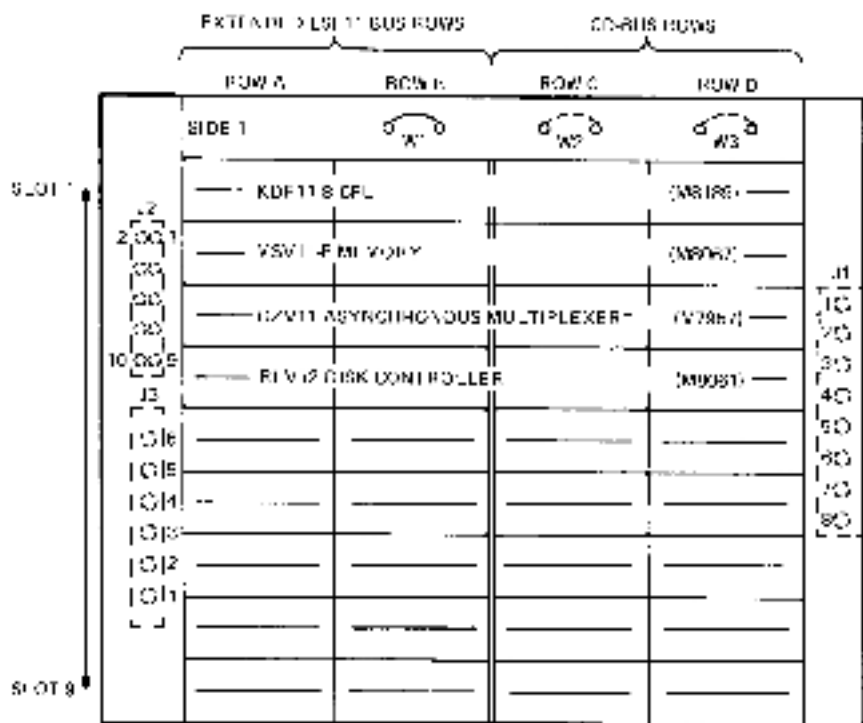

* OF OTHER COMMUNICATION OPTIONS SUCH AS SLV114

NOTE:
VIEW IS FROM MODULE
SIDE OF CONNECTIONS

50-2047

Figure 5-2 Basic PDP-11/23-PLUS System's Module Location in an H9276 Backplane

KDF11-B Microprocessor

The KDF11-B microprocessor (M8189) is a quad-height module that must occupy the first slot in the H9276 backplane. This module contains a central processor, a line frequency clock, bootstrap and diagnostic ROMs, and two serial line units. Five forty-pin sockets located on the module support the standard memory management unit (MMU) and provide for the addition of an optional floating point (FP) or a commercial instruction set (CIS).

The M8189 contains numerous jumpers and two eight-position DIP switches (one for baud rate selection [E114], and one for boot/diagnostic [E102]), as shown in Figure 5-3. These jumpers and switches allow reconfiguration of the module for special application. Table 5-2 lists the factory jumper configurations, while Tables 5-3 and 5-4 list the boot/diagnostic switch and SLU baud rate switch positions. Chapter 6 contains the information required to reposition these jumpers and switches to reconfigure the modules for special applications. More detailed information is presented in the *KDF11-B CPU Module User's Guide*.

Table 5-2 Factory Jumper Configuration

| Jumper | State | Function |
|---------|-------|---|
| J6-J7 | I | Master clock. Enables internal oscillator. |
| J8-J9 | I | Phase. Connects signal to F11 chip Clk drivers. |
| J20-J21 | I | XTAL. Connects baud rate oscillator. |
| J35-J34 | I | LINITF (1) H. Connects reset to console UART. |
| J33-J34 | R | DCOKG2B H. Installed for APT mfg. testing (only after removing jumper J35-J34). |
| J27-J28 | R | Installed for field service wraparound testing (only after removing jumper J27-J28). |
| | | The CPU option jumpers are described in Chapter 2.* |
| J19-J18 | I | Power-up mode 2 (jumper J19-J18 installed; jumper J17-J18 removed) causes the processor to begin executing the bootstrap code at starting address 173000. |
| J17-J18 | R | |
| J16-J18 | R | Processor enters console ODT microcode when it executes a kernel mode halt instruction. |
| | | The on-board device selection jumpers are described in Chapter 2.* |
| J11-J10 | R | LTC ENJ L. BEVENT can request interrupts only if the processor program has set bit 06 of the line clock register (17777346). |
| J12-J10 | R | The second SLU is enabled with an ACSR address of 17776500 and an interrupt vector address of 300 and 304. |
| J13-J10 | R | |
| J14-J10 | R | The console SLU is enabled. |
| J15-J10 | R | The BDV ROMs and registers, as well as the line clock register, are enabled. |
| | | The boot and diagnostic ROM jumpers are described in Chapter 2.* |
| J22-J23 | | Note: When ROMs are used jumper J22 to J23 is installed and jumper J24 to J23 is removed. |
| J24-J23 | | Note: When EPROMs are used jumper J22 to J23 is removed and jumper J24 to J23 is installed. |
| | | The console SLU character formats are described in Chapter 2.* |
| J36-J38 | R | Console SLU parity check is disabled. |
| J37-J38 | I | Console SLU character contains one stop bit. |
| J39-J38 | R | Console SLU character contains 8 bits. |

*Found in the *KDF11-B CPU Module User's Guide*.

Table 5-2 Factory Jumper Configuration (Cont)

| Jumper | State | Function |
|---------|-------|---|
| J40-J38 | R | (No effect; console parity already disabled.) The break halt jumpers are described in Chapter 2.* |
| J3-J4 | R | Break halt feature is disabled. The break key on the console SLU does not halt the processor. |
| J5-J4 | I | This feature may be enabled by removing J5-J4 and then installing J3-J4. The second SLU character formats are described in Chapter 2.* |
| J28-J30 | R | Second SLU parity check is disabled. |
| J29-J30 | I | Second SLU character contains one stop bit. |
| J31-J33 | R | Second SLU character contains 5 bits. |
| J32-J33 | R | (No effect; second SLU parity already disabled.) The internal/external SLU clock jumpers are described in Chapter 2.* |
| J41-J42 | R | The on-board baud rate generator is connected to the console SLU. The external clock input from connector J1 is disabled. |
| J43-J42 | I | |
| J44-J45 | R | The on-board baud rate generator is connected to the second SLU. The external clock input from connector J2 is disabled. The bus grant continuity jumpers are described in Chapter 2.* |
| J46-J45 | I | |
| W1 | I | Provides bus grant continuity for the BIAK signal. |
| W2 | I | Provides bus grant continuity for the BDMG signal. |

*Found in the *KDF 11-B CPU Module User's Guide*

Table 5-3 Bootstrap/Diagnostic Factory Switch Configuration

Switch S1 (E102)

| Number | Position | Function (Note 1) |
|--------|----------|---------------------------|
| 1 | ON | Execute CPU diagnostic |
| 2 | ON | Execute memory diagnostic |
| 3 | OFF | DECnet boot disabled |
| 4 | ON | Console test and dialogue |
| 5 | OFF | |
| 6 | OFF | |
| 7 | ON | RL02 bootstrap program |
| 8 | OFF | |

Note: Power up or restart of the KDF11-B will execute the CPU diagnostic and the memory diagnostic, followed by the console tests after switch S1 is placed in the position as shown. If the operator wishes to terminate the memory diagnostic and immediately enter the console test, the Control/C keys must be depressed on the console terminal.

Table 5-4 SLU Baud Rate Factory Switch Configuration

Switch S2 (E114)

| Number | Position | Function |
|--------|----------|-------------------------------|
| 1 | ON | |
| 2 | OFF | Console SLU set for 9600 baud |
| 3 | OFF | |
| 4 | OFF | |
| 5 | ON | |
| 6 | OFF | |
| 7 | OFF | Second SLU set for 9600 baud |
| 8 | OFF | |

NOTE: Power-up or restart of the KDF11-B will execute the CPU diagnostic and the memory diagnostic, followed by the console tests after switch S1 is placed in the position as shown. If the operator wishes to terminate the memory diagnostic and immediately enter the console test, the Control/C keys must be depressed on the console terminal.

MSV11-P Memory

The MSV11-P memory (M8067) is a quad-height module that occupies the slot adjacent to the KDF11-B module. The M8067 memory contains metal oxide semiconductors (MOS) and random access memory (RAM) and is designed to be used with the extended LSI-11 bus (22-bit address). The MSV11-P provides storage for 18-bit words, 16 data bits and 2 parity bits. It also contains parity control circuitry and a control and status register (CSR). Two light emitting diodes (LEDs) indicate module status. The green LED indicates that +5 V is present on the module; the red LED indicates the detection of a parity error. The three versions of the MSV11-P memory modules used in the basic PDP-11/23-PLUS system are listed in Table 5-5.

Table 5-6 MSV11-P Versions

| Option Designation | Module Designation | Storage Capacity | MOS Chips | Module Population | Number Rows |
|--------------------|--------------------|----------------------------|-----------|-------------------|-------------|
| MSV11-PL | M8067-LA | 256K words (512K bytes) | 64K | Full | 8 |
| MSV11-PK | M8067-KA | 128K words (256K bytes) | 64K | Half | 4 |
| MSV11-PF | M8067-FA | 64K words (128K bytes) | 16K | Full | 8 |

Additional modules are available as options for system expansion. Each additional memory module added to a system requires reconfiguration of the module. This is accomplished by repositioning jumpers on the module's wire-wrap stakes.

The factory configuration for the jumpers is listed in Table 5-6 and shown in Figure 5-4. Refer to Chapter 6 for rules of expansion and jumper relocation information for added memory modules. The *MSV11-P User's Guide* contains more detailed information on the MSV11-P memory module.

Table 5-6 MSV11-P (M8067-LA and KA) Jumper Configuration

| Jumper | State | Function |
|----------|-------|--|
| W1 | I | Grant continuity |
| W2 | I | Grant continuity |
| W3 | R | Power jumper -5 V |
| W4 | I | Power jumper, decoupler +5 V |
| W5 | I | Power jumper, decoupler +5 V |
| W9 | I | Power jumper |
| W10 | R | Power jumper |
| W11 | R | Power jumper |
| W12 | R | Power jumper |
| W13 | I | Power jumper |
| W14 | R | Power jumper |
| W15 | I | Power jumper |
| 6 to 7 | I | Write wrong parity |
| 8, 21 | R | Ground |
| 3 to 8 | I | Row latch -- 64K MOS chip |
| 4 to 10 | I | Row latch -- 64K MOS chip |
| 14 to 18 | I | Column latch -- 64K MOS chip |
| 13 to 15 | I | Column latch -- 64K MOS chip |
| 44 to 45 | I | Multiple voltage MOS RAM access time inhibit |
| 22 to 23 | I | Inhibit |
| A | R | CSR address |
| B | R | |
| C | R | Address bits |
| D | R | |

Table 5-6 MSV11-P (M8067-LA and KA) Jumper Configuration (Cont)

| Jumper | State | Function |
|--------|-------|------------------|
| E | R | Ground |
| L | R | Starting address |
| M | R | |
| N | R | |
| P | R | |
| R | R | Ground |
| S | R | |
| T | R | |
| U | R | Ground |
| V | R | |
| W | R | |
| X | R | |
| Y | R | Ground |

DZV11 Asynchronous Multiplexer

The DZV11 asynchronous multiplexer (M7957) is a quad-height module that occupies the slot adjacent to the last memory module in the backplane. This module provides an interface through the distribution panel with the KDF11-B processor and up to four asynchronous serial data communication channels.

The M7957 provides EIA interface levels. It also provides enough data set control to permit dial-up (auto answer) operation with modems using full-duplex operations.

There are sixteen jumpers and two DIP switches on the M7957 module that are used to change the operation of the DZV11 for specific applications. The location of jumpers and switches, shown in Figure 5-5 and listed in Tables 5-7 and 5-8, are for the basic PDP-11/23-PLUS system. Refer to Chapter 6 for expansion information.

RLV12 Disk Controller

The RLV12 disk controller (M8061) is a quad-height module that occupies the backplane slot adjacent to the DZV11 module. The M8061 controls the two RL02 disk drives in the PDP-11/23-PLUS system. This module transfers data to and from the extended LSI-11 bus using direct memory access (DMA) transactions (transactions that do not first go to the processor). The RLV12 is factory configured for 22-bit addressing with a starting address (octal) of 17774400. The device starting address is selected by the position of the jumpers shown in Figure 5-6. Detailed information for the RLV12 module is presented in the *RLV12 Disk Controller User's Guide*.

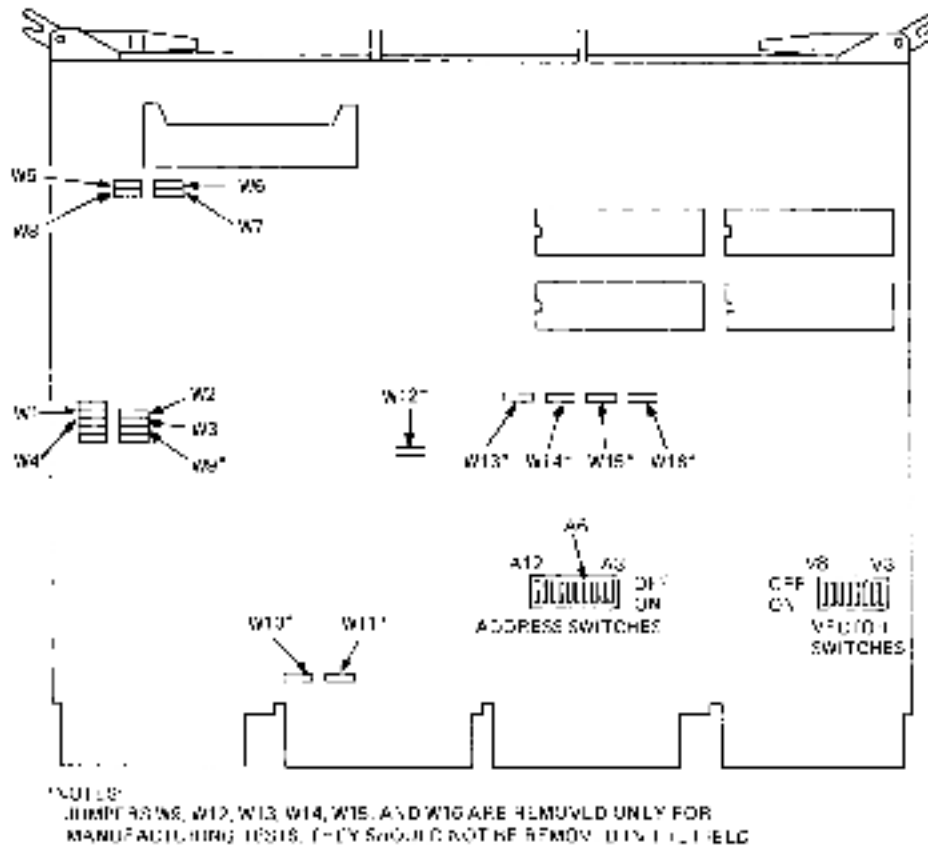

DA-1277

Figure 5-5 DZV11 Factory Jumper and Switch Locations

Table 5-7 DZV11 (M7967) Jumper Configuration (Basic System)

| Jumper | Jumper Installed | Function |
|--------|------------------|---|
| W1 | R | Connects data terminal ready (DTR) to request to send (RTS) |
| W2 | R | |
| W3 | R | |
| W4 | R | |
| W5 | R | Connects forced busy (FB) to request to send (RTS) |
| W6 | R | |
| W7 | R | |
| W8 | R | |
| W9 | I | Bus signals |
| W10 | R | |
| W11 | R | |
| W12 | I | |
| W13 | I | |
| W14 | I | |
| W15 | I | |
| W16 | I | |

I — installed
R — removed

Table 5-8 DZV11 (M7857) Factory Switch Setting

| Number | Switch | Position |
|--|--------|----------|
| Address Switch Selection (160100) | | |
| A3 | 10 | OFF |
| A4 | 9 | OFF |
| A5 | 8 | OFF |
| A6 | 7 | ON |
| A7 | 6 | OFF |
| A8 | 5 | OFF |
| A9 | 4 | OFF |
| A10 | 3 | OFF |
| A11 | 2 | OFF |
| A12 | 1 | OFF |
| Vector Switch Selection (300) | | |
| V3 | 6 | OFF |
| V4 | 5 | OFF |
| V5 | 4 | OFF |
| V6 | 3 | ON |
| V7 | 2 | ON |
| V8 | 1 | OFF |

BA11-S Mounting Box

The BA11-S mounting box houses a 70 cfm fan to cool the logic modules, a 100 cfm fan to cool the power supply, an H9276 backplane with a card frame assembly, an H7861 power supply, and an H403 ac input box. The BA11-S is shown in Figure 5-7.

H9276 Backplane – The H9276 is a 9 × 4 backplane consisting of nine slots with four rows each (Figure 5-8). Both double and quad-modules can be inserted. Rows A and B of each slot supply the extended LSI-11 bus signals, which are bussed to each of the nine rows. The pins of the C and D rows are connected to the pins of adjacent rows. The factory configuration of jumpers on the backplane is shown in Figure 5-8.

H7861 Power Supply* – The H7861 power supply contains three circuit boards that supply +12 Vac and +5 Vdc to the backplane.

H403-B AC Input Box* – The H403 B ac input box receives the ac input power and distributes it to the power supply and the fans. The input box provides a fused input and a switch used to adapt for either 120 Vac or 240 Vac. This switch is located on the rear of the 11/23B processor shown in Figure 3-6.

*More detailed information is contained in the *PDP 11/23B Mounting Box Technical Manual*.

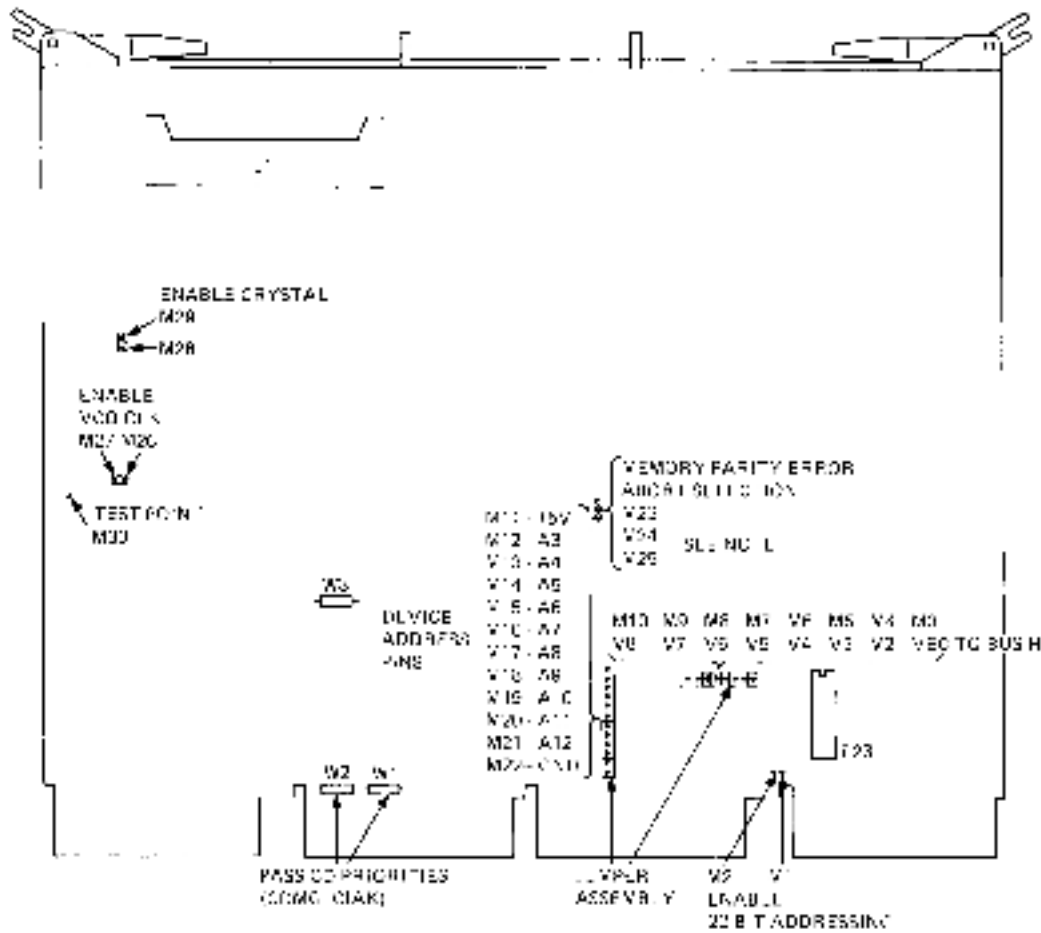

NOTE
 THE MEMORY PARITY ERROR ABORT FEATURE IS AVAILABLE FOR USE WITH MEMULS THAT HAVE PARITY ERROR CHECKING. FIRSTLY, THE DUAL IN-LINE DEVICES MUST BE DISABLED FOR VENDORS THAT DO NOT HAVE PARITY ERROR CHECKING. THE PINS ARE CONFIGURED AS FOLLOWS.

| CONNECTION | FUNCTION |
|------------|--------------------|
| M23-M24 | NO PARITY |
| M25-M26 | PARITY ERROR ABORT |

5112240

Figure 5-6 RLV12 Factory Jumper Locations

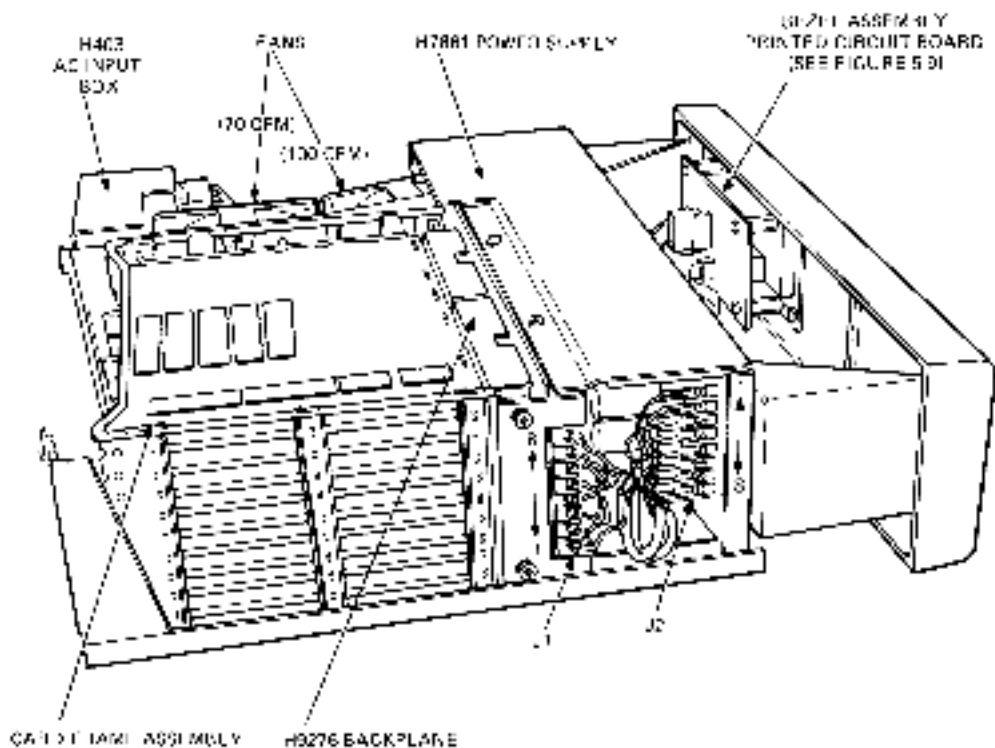

DA-1927

Figure 5-7 DA11-S Major Assemblies

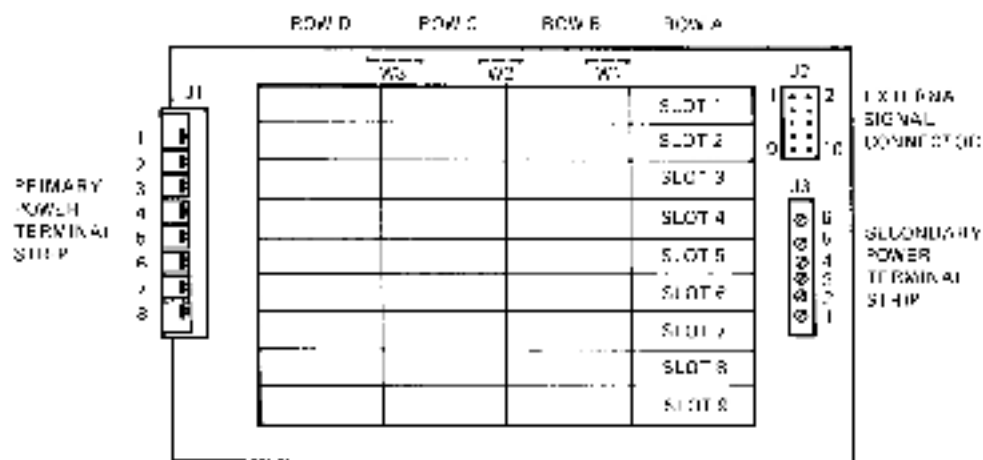

DA-1928

Figure 5-8 H9276 Connector and Jumper Locations

Control Panel – The control panel is equipped with switches and LEDs (Figure 1-2) used by the PDP-11/23-PLUS system. The circuit board for the control panel is factory configured by the jumpers shown in Figure 5-9 and described in Table 5-9. The connection for the remote power cable is shown as J2 in Figure 5-9.

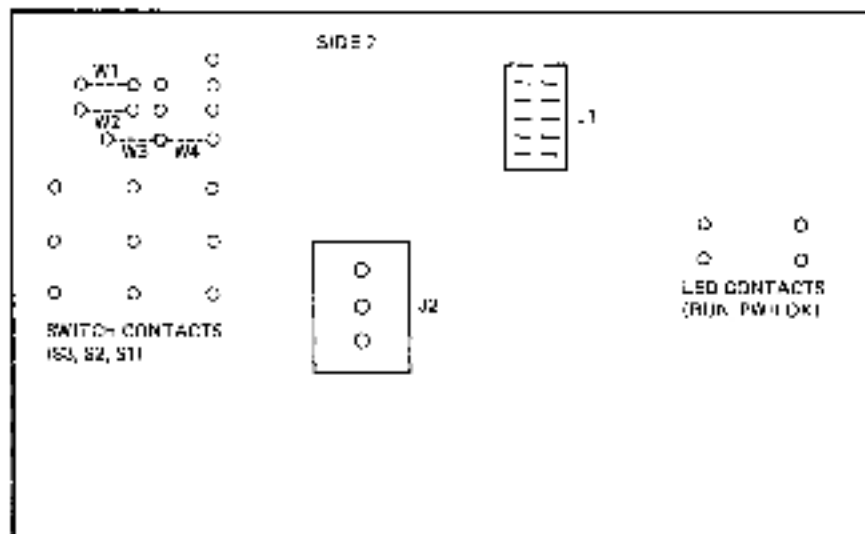
**NOTES**

1. VIEW IS FROM THE REAR OF THE BEZEL WHEN THE BOARD IS MOUNTED ON THE BEZEL.
2. JUMPERS ARE MOUNTED ON SIDE 1.

11-6278

Figure 5-9 Control Panel Printed Circuit Board

Table 5-9 Control Panel Jumpers

| Jumper | State ¹ | Function |
|--------|--------------------|---|
| W1, W2 | R | Allows remote control of power by the AUX ON/OFF switch. |
| W3 | R | Processor is mounted into this control panel's backplane. |
| W4 | I | Enables the RUN indicator because the CPU is mounted in this backplane. |

I – installed
R – removed

¹More detailed information is contained in the *PDP-11/23B Mounting Box Technical Manual*.

H349 DISTRIBUTION PANEL

The H349 distribution panel is located directly behind the PDP-11/23B processor subsystem and is accessible from the rear of the system. The panel provides simple and convenient means of interfacing peripheral equipment with the PDP-11/23B processor subsystem.

This 28.32 cm (11.15 in) by 44.10 cm (18 in) hinged panel is held in its vertical position by two quarter-turn captive screws and can swing down to a horizontal position in order to service the PDP-11/23B processor subsystem.

The H349 panel contains ten mounting locations that provide mounting for up to fifteen connector (J1 through J15) cable assemblies, as illustrated in Figure 5-10. Eleven cable assemblies contain 1×4 slots (J1 through J11) and four contain 4×4 slots (J12 through J15). An adapter is available to transform four of the 1×4 slots (J8 through J11) into a 4×4 slot. When mounted, each cable assembly is connected to the PDP-11/23B processor subsystem by ribbon cables.

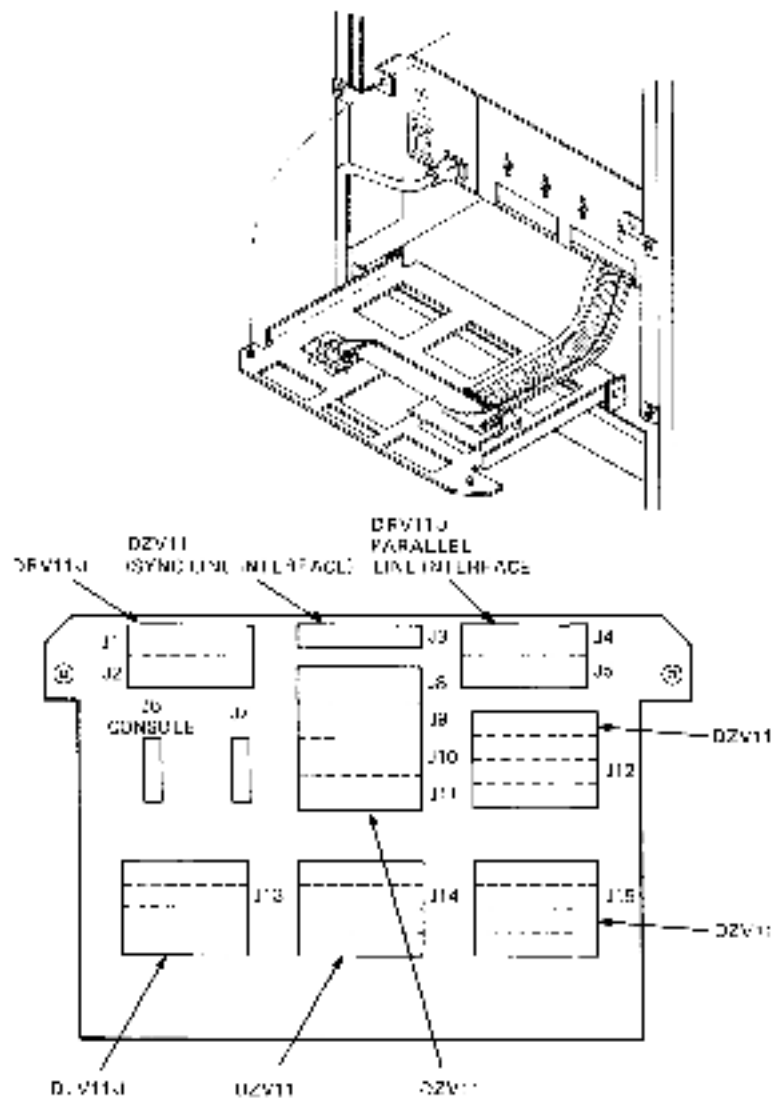

MH 1278

Figure 5-10 PDP-11/23-PLUS Distribution Panel (H349)

All system configurations contain the KDF 11-B cable assembly, which provides console and printer connections to the two serial lines on the KDF11-B microprocessor module. Systems containing a DZV11-C module are cabled to connector J12. Table 5-10 lists suggested mounting locations for the cable assemblies of available PDP-11/23-PLUS system options.

Table 5-10 Distribution Panel Cable Assemblies to PDP-11/23-PLUS System Options

| Option | Module | Cable Assembly | Extension Cable |
|--|----------------|----------------------------|--|
| DLV11-E0 | M8017 | BC03L-2F | BC05D-25 or BC03M-25 or BC22A-25 |
| DLV11-J | M8043 | 7018204-00 | BC22A-25 |
| DMV11-AA DMV11-AC | M8053 M8054 | BC55H-03 BC55F-03 | BC05D-25 (EIA) HC55M-95 (Local) |
| DPV11-DC | M8020 | 7018209-00 | BC05D-25 or HC22B-22 |
| DZV11-C | M7957 | 7018203-00 | BC05D-25 or BC03M-25 or BC22A-25 |
| DRV11-D DRV11-JA | M7941 M8049 | 7012406-02 | BC08R-25 |
| IBV11-C | M7954 | * | * |
| LPV11-AC LPV11-BC LPV11-EE LPV11-EF | M8027 | BC06K-4B and 1214814-01 | 7011212-25 |

*Request cable part numbers from DIGITAL's local Sales office.

RL02 DISK SYSTEM

The RL02 disk drive is a random access, mass storage system that stores data in fixed-length blocks on a preformatted disk cartridge. Each drive can store 10.48 million bytes, and the two RL02 drives can store over 20 million bytes. The RLV12 interface controller transfers data from the extended LSI 11 bus by using direct memory access (DMA) techniques. This allows data transfers without any processor interruptions at the bus bandwidth speed. The RLV12 interface controller can interface with four RL02 disk drives.

H9642 CONSOLE CABINET

The console cabinet is the H9642 free-standing unit, which is 101.6 cm (40.00 in) high, 54 cm (21.25 in) wide, and 76 cm (30.00 in) deep. The cabinet has a vented backpanel that can be removed. The side panels are also removable. (See Chapter 8.)

874 POWER CONTROLLER

The 874 power controller, located on the rear base of the console cabinet, contains the main circuit breaker for the system. The system component line cords are plugged into the outlets provided on the controller. The remote operation cable also plugs into a connector mounted on the controller and allows the operator to turn on the ac power from the AUX ON/OFF switch (Figure 1-2). There are three configurations for the power controller. 120 Vac systems use the 874-A rated at 12 A and the 874-C rated at 16 A. The 874-B rated at 8 A is used on 240 Vac systems.

CHAPTER 6 OPTIONAL SYSTEM COMPONENTS

INTRODUCTION

The basic PDP-11/23-PLUS system offers a choice of terminals. The KDF11-B contains the serial line unit that connects any of the standard DIGITAL terminals via a standard EIA configuration (except for modem control). The selected terminal can be interfaced with the KDF11-B serial line unit through the distribution panel, as shown in Figure 6-1; or it can be operated in a remote location and interfaced with an EIA data set, as in Figure 6-2.

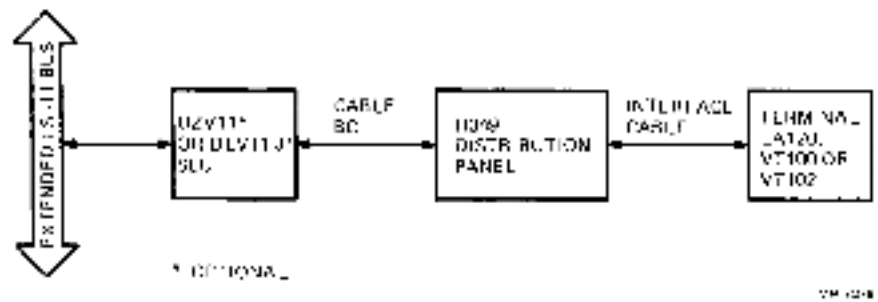

Figure 6-1 Standard EIA Interface

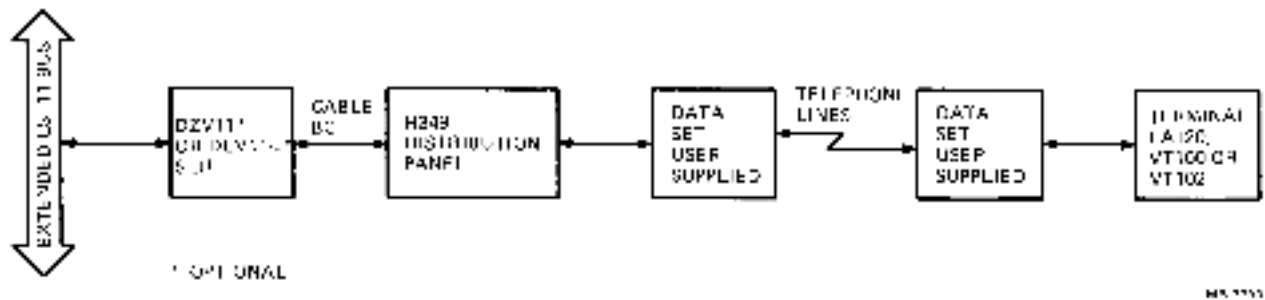

Figure 6-2 Telephone Line Interface Via Data Set

TERMINAL OPTIONS

Terminals recommended for the PDP-11/23-PLUS are the VT100 Video Terminal, the VT102 Video Terminal, and the LA120 DECwriter III. The following paragraphs describe the features of each of these terminals. Refer to the appropriate user's manual for installation procedures and terminal operation.

VT100 and VT102 Terminals

The VT100 (Figure 6-3) and VT102 are video terminals with detachable keyboards. They use a nonvolatile memory that remembers the features selected during a setup mode. The features that can be set up include tab stops, margins, characters per line (80 or 132), smooth or jump scrolling, auto-repeat of every character, dark or light screen, XON/XOFF, ANSI or VT52 escape sequences, keystroke click, margin bell, line wraparound, auto-new-line, interlaced or noninterlaced modes, 50 or 60 Hz, odd or even parity, and transmit and receive speed. The VT102 video terminal contains a built-in advance video and is not expandable.

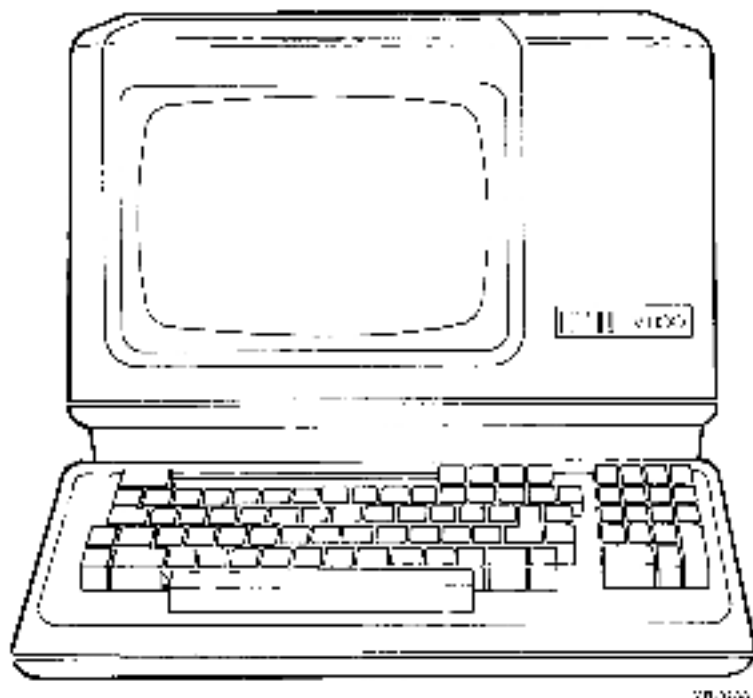

Figure 6-3 VT100 Video Terminal

When the terminal is in the setup mode the status of its features is displayed on the screen. Each feature may then be individually changed, either temporarily or permanently, with a **SAVE** operation. The basic VT100 and VT102 include:

- 24 lines of 80 or 132 columns

- Detachable keyboard with electric typewriter layout

- Numeric function keyboard

- Asynchronous data communication at individually programmed transmit and receive baud rates from 75 to 19200 baud

- ASCII code utilized, plus ANSI standard commands using escape sequences

- Horizontal tabs

- Easy interfacing with 20 mA current loop or RS232C levels

- Keystroke click for rhythmic typing (may be disabled)

- Three-key rollover protection

- Full-duplex operation.

Summary of VT100 and VT102 Specifications

Dimensions

| | |
|---------|----------------------------|
| Height | 36.8 cm (14.5 in) |
| Width | 45.7 cm (18.0 in) |
| Depth | 51.4 cm (20.3 in) |
| Monitor | 30.5 cm (12.0 in) diagonal |

Power consumption 100 W (max)

Phosphor P4

NOTE: Refer to the VT100 or VT102 user's guide for detailed specifications.

LA120 DECwriter III

The LA120 (Figure 6-4) is a highly reliable, 180 characters-per-second impact printer that prints bidirectionally. It uses a nonvolatile memory that remembers the features selected during the setup mode.

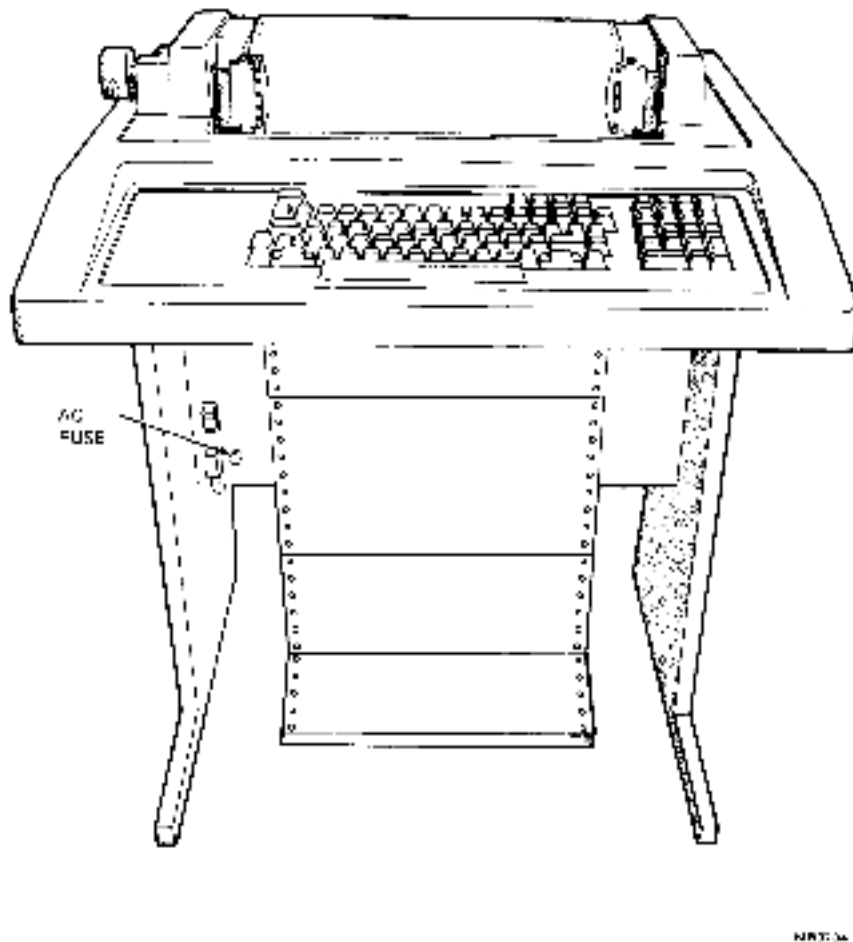

Figure 6-4 LA120 DECwriter III

The form features are lines per inch, form length, top of form, vertical margins and tabs, horizontal margins and tabs, and characters per inch. The operator comfort features include auto-repeat, lost character view, bell volume, and keystroke click. The communication features are baud rate, answerback, buffer control, keyboard and character set, auto-disconnect, local echo, auto-new-line, auto-line-feed, modem, half duplex, secondary channel, parity and data bits, printer new line character, and XON/XOFF function. The LA120 DECwriter III basic features are as follows. (Refer to the *LA120 User's Guide* for printer specifications.)

Dimensions

| | |
|--------|-------------------|
| Width | 69.9 cm (27.5 in) |
| Height | 85.1 cm (33.5 in) |
| Depth | 61.0 cm (24.0 in) |
| Weight | 46.4 kg (102 lb) |

BA11-S EXPANDER BOX

The basic PDP-11:23-PLUS system has five slot positions available for adding options. Adding an expander box makes eight additional slot positions available for a total of twelve for system expansion.

NOTE: The last slot of the computer backplane and the first slot of the expander box are reserved for the connection of the BC02D-03 cable. (See Figure 8-1.)

In addition to the BA11-SC (120 Vac) expander box, the BC02D-03 jumper cable/terminator assembly is required to connect the existing backplane to the backplane in the expander box. A sample of an expanded system is shown in Chapter 8. The available system expansion options are listed below.

| Option | Description |
|----------|---|
| BA11-SC | An expander box that includes a 9 × 4 backplane and a power supply for use in a 120 Vac system. |
| BC02D-03 | The jumper cable/terminator assembly consists of two modules (M9405-YA and M9404-00) interconnected by two 91 cm (3 ft) 40-conductor BC02D-03 connector cables. |







CHAPTER 7 SYSTEM REQUIREMENTS

INTRODUCTION

This chapter describes the system power, environment, and mechanical characteristics of the PDP-11/23-PLUS. This system is designed to operate in a business or light industry setting. The system's environment, however, should be within the limits defined by this chapter.

SYSTEM POWER

The basic difference between the variations of the PDP-11/23-PLUS is the power controller. Figure 7-1 shows the power connectors used on each model. Refer to Table 7-1 for system identification and Table 7-2 for terminal options according to the type of power available.

| LOCAL POWER | POWER CONTROLLER | |
|------------------------|---|---|
| | PLUG | RECEPTACLE |
| 120V 15A 60/50/60Hz |  NEMA # 5-15P DEC # 90-09932 |  E-15R 12-14829 |
| 240V 15A 60/50/60Hz |  NEMA # 6-15P DEC # 90-09952 |  R-15R 12-11204 |
| 120V 20A 60/50/60Hz |  HUBBELL # 6388-C DEC # 12-15183 |  NEMA # 5-20R 12-12265 |

- * NON-EXPANDABLE SINGLE BOX SYSTEM
- ** EXPANDABLE BOX SYSTEM

Figure 7-1 PDP-11/23-PLUS Power Connectors

Table 7-1 System Model Designations

| PDP-11/23-PLUS | BH* | BJ** |
|------------------|--------------|-------------|
| Input voltage | 120 Vac | 240 Vac |
| Power controller | 874-A | 874-B |
| Current rating | 16 A rms max | 8 A rms max |
| Frequency | 50-60 Hz | 60-60 Hz |
| | *BK, BM, BN | |
| | **BL, BN, BR | |

Table 7-2 Optional Console Terminals

| Terminal | 120 V/60 Hz | 240 V/60 Hz | 120 V/50 Hz | 240 V/50 Hz |
|----------|-------------|-------------|-------------|-------------|
| LA120 | HA | -DA | -BA | -DA |
| VT100 | AA | -AB | -AA | -AB |
| VT102 | AA | -AB | -AA | -AB |

ENVIRONMENT

The environment is an important consideration in the installation of any computer system, but it is particularly crucial for the proper operation of a system with disk drives. Altitude affects the flying height of read/write heads in disks, and excess humidity and mechanical shock should be avoided. The following specifications should be considered when selecting the environment of the PDP-11/23-PLUS.

| Environmental Conditions | Specifications |
|------------------------------|---|
| Altitude | 2400 m (8000 ft) max |
| Operating temperature | 10° to 40° C (50° to 104° F) nominal; reduce temperature 1.8° C/1000 m (1° F/1000 ft) |
| Maximum wet bulb temperature | 28° C (82° F) |
| Minimum dew point | 2° C (36° F) |
| Storage temperature | 40° C (104° F) to 66° C (151° F) |
| Temperature change rate | 15.6° C (30° F) per hour |
| Relative humidity | 10% to 90% (no condensation) |
| Maximum shock pulse | 10 g's peak (half-sine) for 10 ± 3 ms duration |

| Environmental Conditions | Specifications |
|--------------------------|----------------|
| Pitch and roll | 1.5° maximum |
| Power requirements | |
| PDP-11T23B system | 360 W |
| Optional LA120 | 440 W |
| Optional VT100 | 100 W |
| Optional VT102 | 100 W |

Heat Dissipation

The heat dissipation factor for the RL02 disk system is less than 600 Btu/hr. The approximate cooling requirements for the system are determined by adding 600 Btu/hr to the total heat dissipation for the other system components and then adjusting the result to compensate for such factors as the number of personnel, the heat radiation from adjoining areas, and sun exposure through windows. It is advisable to allow a safety margin of at least 25 percent above the maximum estimated requirements.

Radiated Emissions

Because magnetic fields can have adverse effects on disks, sources of radiation such as FM, vehicle ignitions, and radar transmitters located close to the computer system may affect the performance of the RL02 disk system. A magnetic field with an intensity of 50 oersteds or greater might destroy all or some of the information recorded on the disk.

Cleanliness

Cleanliness is important in all facets of a computer system, but it is particularly important in the case of moving magnetic media such as the RL02. Therefore, the PDP-11/23-PLUS should not be subjected to contaminated atmospheres. An environment that contains abrasive airborne particles is particularly damaging to the system.

NOTE: The RL02 uses a removable disk pack that requires handling and maintenance which are beyond DIGITAL's direct control. DIGITAL disclaims responsibility for performance of the equipment when operated with disk packs not meeting DIGITAL specifications or with a disk pack that has been damaged or not maintained in accordance with procedures approved by DIGITAL. DIGITAL shall not be liable for damages to the equipment or media resulting from such operation.

Cooling

Proper ventilation for the system's components is very important. The vents on the rear panel of the computer cabinet must be kept clear, and a minimum clearance of 10 cm (4 in) must be maintained at the rear of the cabinet. The lower panels on the front of the cabinet must be kept closed to ensure proper air flow through the equipment. Side panels can be butted together.

Static Electricity

Static electricity may interfere with the system's operation. If the system is used in an environment with very low humidity, it is advisable to use a humidifier or to place the system on a tile floor rather than on carpeting.

Disk Cartridge Storage

An additional metal cabinet with doors should be provided for storage of disk cartridges, which have a diameter of 38.4 cm (15 in) and a height of 6.2 cm (2.5 in).

CAUTION: RLO2 disk cartridges must never be stacked on top of each other. A designated shelf area or specifically designed disk cartridge storage area is recommended.

CHAPTER 8 RULES FOR EXPANSION

INTRODUCTION

The PDP-11/23-PLUS is expanded by adding a BA11-SC (120 V) expander box and a BC02D-03 expander cable. The cable plugs into the last slot of the computer backplane and the first slot of the expander box (Figure 8-1). Optional modules can be added, up to the capacity of the space or power supply. Refer to the two-volume Microcomputer Handbook series for details of module power requirements and computer power limitations. The *PDP-11/23B Mounting Box Technical Manual* provides details for installing and using these expander boxes.

NOTE: DIGITAL assumes no responsibility for compliance to FCC regulations when the system is expanded beyond the guidelines presented in this document.

PRIORITY CHAINING

The position of the module in the computer backplane determines the device's priority. A signal passes through each module in turn. The closer a module is to the microprocessor, the higher is its hardware priority.

Either quad- or double-sized modules that conform to extended LSI-11 specifications can be added to the H9276 backplane. Double-sized modules that require the use of the extended LSI-11 bus must be installed in slots A and B only.

The microprocessor module is always installed in slot one followed by one or more memory modules.

MULTIPLE BACKPLANE CONFIGURATION RULES

1. No more than three backplanes can be connected together. Two and three backplane configurations are shown in Figures 8-1 and 8-2, respectively.
2. Each backplane can have no more than 20 ac loads.
3. The total number of dc loads cannot be more than 20.

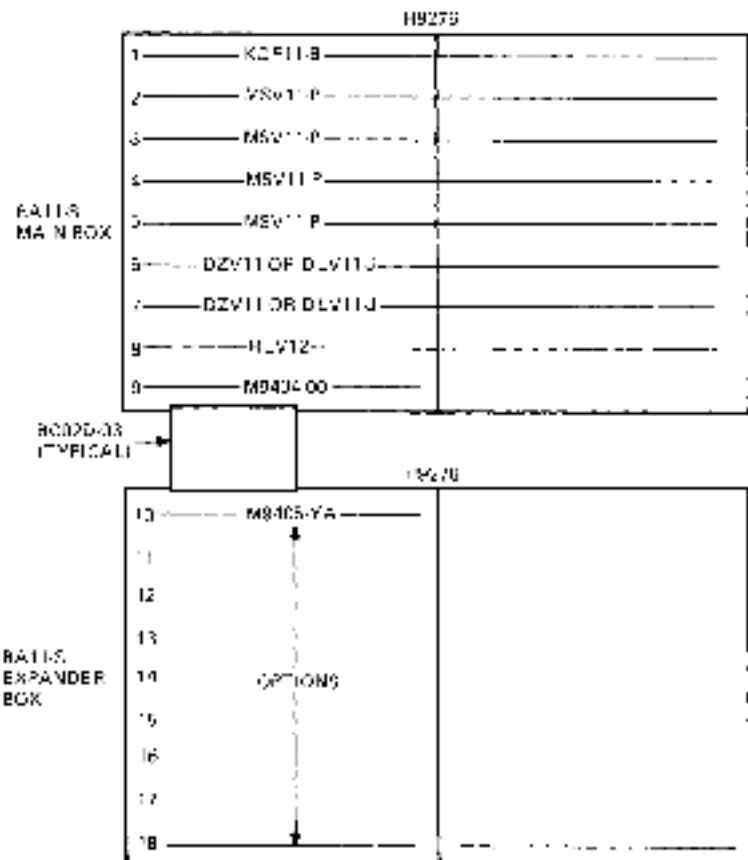

PDP-11/23 PLUS SYSTEM RESTRICTIONS:

THE HLVT2 MUST HAVE JUMPER M22 TIED TO M17, M20 AND M21, AND JUMPER M11 TIED TO M12 FOR 22 BIT ADDRESSING.

MSV11A AND MSV11-B (NOT SUPPLIED) MEMORY MODULES SHOULD NOT BE USED TOGETHER IN THE SAME SYSTEM.

Figure H-1 PDP-11/23-PLUS System (H9276) Two Backplane Configuration

4. Both ends of the termination line must be terminated with 120 ohm;* i.e., the first backplane must have an impedance of 120 ohms and the last backplane must have a termination of 120 ohms.
5. The cable connecting the first two backplanes, the main box and expander box 1, must be at least 91 cm (3 ft) long.
6. The cable connecting the backplane of expander box 1 to the backplane of expander box 2 is typically at least 305 cm (4 ft) long. This length is recommended for ease of installation.
7. The combined length of both cables in the three backplane system cannot exceed 488 cm (16 ft).

*The KDF11-B CPU module contains 120 ohm bus termination and thus does not require an external termination module.

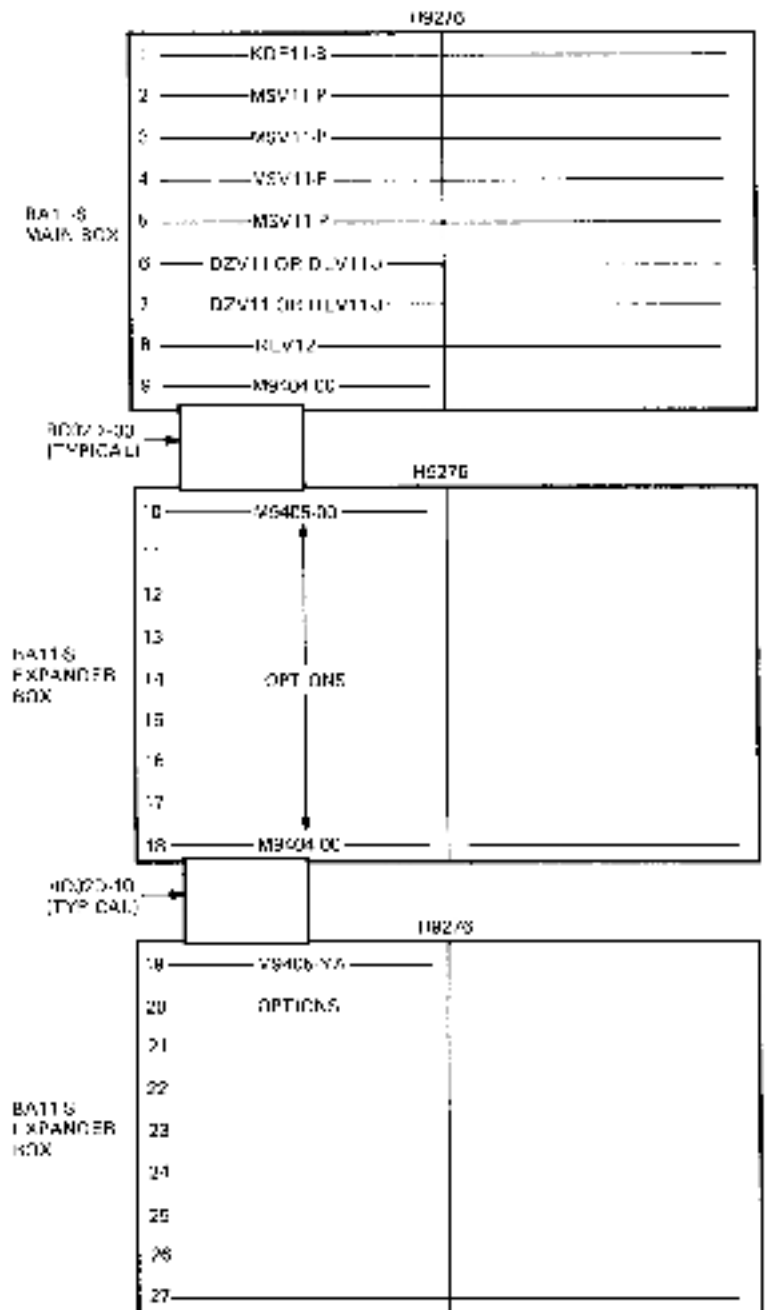

011-6907

Figure 8-2 PDP-11/23-PLUS System Three Backplane Configuration

MICROPROCESSOR RECONFIGURATION

The KDF11-B microprocessor is capable of handling up to 512K bytes of address space. The microprocessor is factory configured with 256K or 512K bytes of memory depending on the memory option chosen for a PDP-11/23-PLUS system. Factory configuration of the KDF11-B module for a PDP-11/23-PLUS system is presented in Chapter 5.

The KDF11-B contains two DIP switch units (E102 and E114) and twelve jumpers that select the desired module features. Figure 8-3 shows the location of these jumpers and switches. The jumpers and switches are divided into the following groups.

- CPU option
- Device selection
- Boot and diagnostic ROM
- Serial line units
- Internal/external SLU clock jumpers
- Test jumpers

CPU Option

Four wire-wrap stakes provide user selected features for the central processor unit (CPU) that include the power-up mode and halt/trap option. The jumper configuration for the CPU power-up mode and halt/trap option are listed in Table 8-1.

Table 8-1 CPU Jumper Configuration

Power-Up Mode Jumper

| Mode | Jumpers | | | Name/Function |
|------|----------|----------|----|--------------------|
| | 18 to 17 | 18 to 16 | 19 | |
| 0 | R | - | R | PC @ 24, PS @ 28 |
| 1 | I | - | R | Console ODT |
| 2 | R | - | I | Bootstrap |
| 3 | I | - | I | Extended microcode |

Halt/Trap Jumper

| | | | | |
|--------|---|---|---|---|
| Kernel | - | R | - | Processor enters console ODT microcode when it executes a halt instruction. |
| Kernel | - | I | - | Processor traps to location 10g when it executes a halt instruction. |
| User | - | X | - | Halt instruction decode results in a trap to location 10g regardless of the status of the halt/trap jumper. |

*R - removed
I - installed
X - don't care

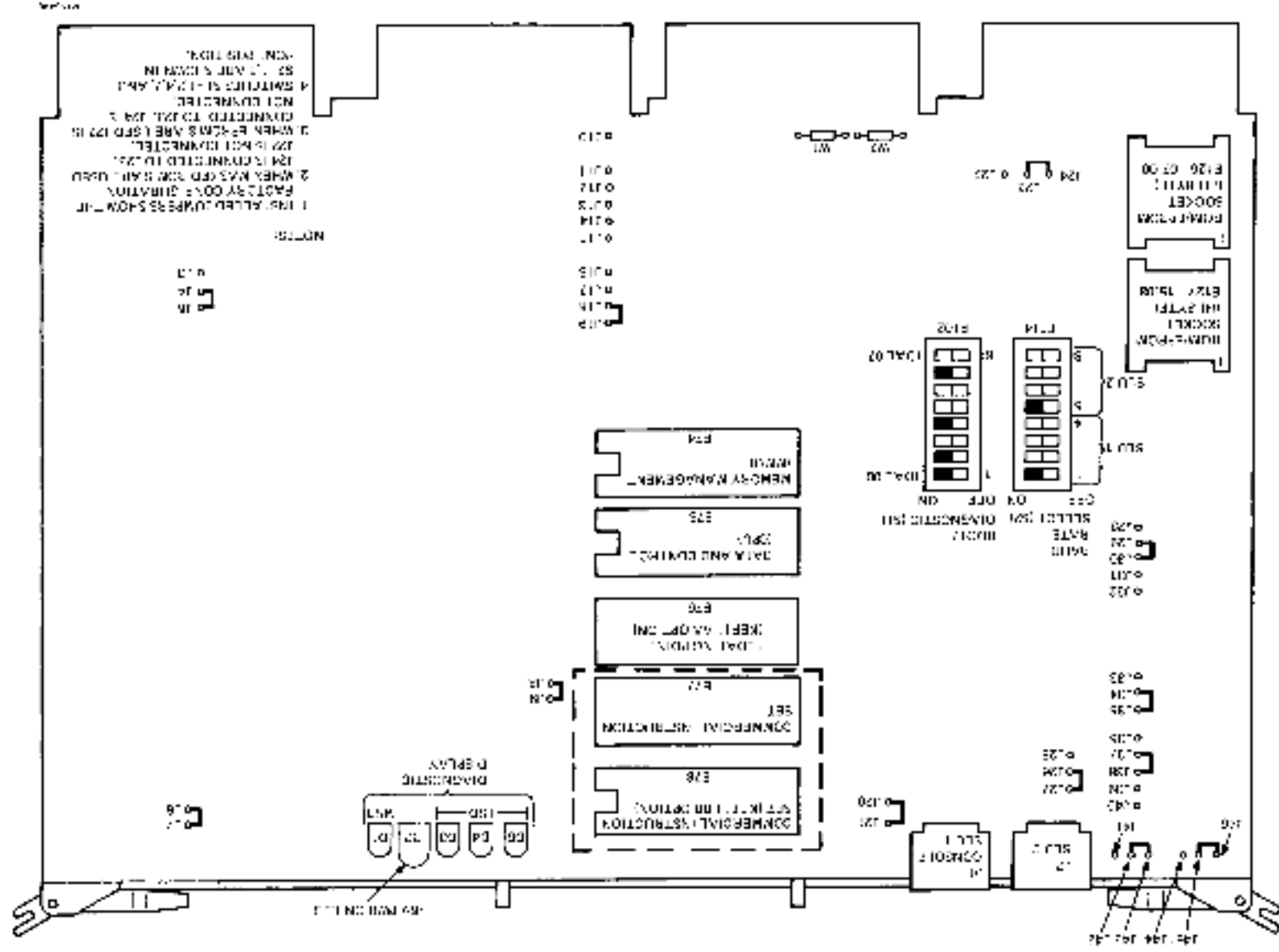

Figure H-3. KDF 11-B Jumper, Switch, and Diagnostic Display Locations

Device Selection

Six wire-wrap stakes are used to select which on-board peripheral devices are enabled or disabled. The jumper functions are presented in Table 8-2.

Table 8-2 On-Board Device Selection Jumpers

| Stake Number | Stake Name | Function | | | | | | | | | | | | | | | | | | | | | | | | | | | | | | | | | | | | | | | | |
|------------------|------------|---|------------------|--|-------------------|--|------|--------|----------|-----|------|--------|-------------|-----|------|--------|--|--|------|--------|--|--|------------------|--|-------------------|--|------|--------|----------|-----|------|--------|-------------|-----|------|--------|--|--|------|--------|--|--|
| J10 | Ground | This wire-wrap stake provides a ground source for the other five wire-wrap stakes in this group. | | | | | | | | | | | | | | | | | | | | | | | | | | | | | | | | | | | | | | | | |
| J15 | BDK DISJ L | When grounded, this signal disables the boot/diagnostic registers, the boot/diagnostic ROMs, and the line clock register. | | | | | | | | | | | | | | | | | | | | | | | | | | | | | | | | | | | | | | | | |
| J14 | DL1 DISJ L | When grounded, this signal disables the console serial line registers. When ungrounded, the device and vector addresses for the console SLU are the following. <table border="1" data-bbox="467 925 999 1074" style="margin-left: 40px;"> <thead> <tr> <th colspan="2">Device Addresses</th> <th colspan="2">Interrupt Vectors</th> </tr> </thead> <tbody> <tr> <td>RCSR</td> <td>777560</td> <td>Receiver</td> <td>080</td> </tr> <tr> <td>RBUF</td> <td>777562</td> <td>Transmitter</td> <td>084</td> </tr> <tr> <td>XCSR</td> <td>777564</td> <td></td> <td></td> </tr> <tr> <td>XBUF</td> <td>777566</td> <td></td> <td></td> </tr> </tbody> </table> | Device Addresses | | Interrupt Vectors | | RCSR | 777560 | Receiver | 080 | RBUF | 777562 | Transmitter | 084 | XCSR | 777564 | | | XBUF | 777566 | | | | | | | | | | | | | | | | | | | | | | |
| Device Addresses | | Interrupt Vectors | | | | | | | | | | | | | | | | | | | | | | | | | | | | | | | | | | | | | | | | |
| RCSR | 777560 | Receiver | 080 | | | | | | | | | | | | | | | | | | | | | | | | | | | | | | | | | | | | | | | |
| RBUF | 777562 | Transmitter | 084 | | | | | | | | | | | | | | | | | | | | | | | | | | | | | | | | | | | | | | | |
| XCSR | 777564 | | | | | | | | | | | | | | | | | | | | | | | | | | | | | | | | | | | | | | | | | |
| XBUF | 777566 | | | | | | | | | | | | | | | | | | | | | | | | | | | | | | | | | | | | | | | | | |
| J13 | DL2 DISJ L | When grounded, this signal disables the second serial line registers. When ungrounded, the device and vector addresses for the second SLU are determined by the status of the DL2 ADRJ L jumper. | | | | | | | | | | | | | | | | | | | | | | | | | | | | | | | | | | | | | | | | |
| J12 | DL2 ADRJ L | When DL2 ADRJ L is ungrounded, the second SLU device and vector addresses are as follows. <table border="1" data-bbox="467 1330 999 1478" style="margin-left: 40px;"> <thead> <tr> <th colspan="2">Device Addresses</th> <th colspan="2">Interrupt Vectors</th> </tr> </thead> <tbody> <tr> <td>RCSR</td> <td>776500</td> <td>Receiver</td> <td>300</td> </tr> <tr> <td>RBUF</td> <td>776502</td> <td>Transmitter</td> <td>304</td> </tr> <tr> <td>XCSR</td> <td>776504</td> <td></td> <td></td> </tr> <tr> <td>XBUF</td> <td>776506</td> <td></td> <td></td> </tr> </tbody> </table> <p>When DL2 ADRJ L is grounded, the device and vector addresses are as follows.</p> <table border="1" data-bbox="467 1585 999 1734" style="margin-left: 40px;"> <thead> <tr> <th colspan="2">Device Addresses</th> <th colspan="2">Interrupt Vectors</th> </tr> </thead> <tbody> <tr> <td>RCSR</td> <td>776540</td> <td>Receiver</td> <td>340</td> </tr> <tr> <td>RBUF</td> <td>776542</td> <td>Transmitter</td> <td>344</td> </tr> <tr> <td>XCSR</td> <td>776544</td> <td></td> <td></td> </tr> <tr> <td>XBUF</td> <td>776546</td> <td></td> <td></td> </tr> </tbody> </table> | Device Addresses | | Interrupt Vectors | | RCSR | 776500 | Receiver | 300 | RBUF | 776502 | Transmitter | 304 | XCSR | 776504 | | | XBUF | 776506 | | | Device Addresses | | Interrupt Vectors | | RCSR | 776540 | Receiver | 340 | RBUF | 776542 | Transmitter | 344 | XCSR | 776544 | | | XBUF | 776546 | | |
| Device Addresses | | Interrupt Vectors | | | | | | | | | | | | | | | | | | | | | | | | | | | | | | | | | | | | | | | | |
| RCSR | 776500 | Receiver | 300 | | | | | | | | | | | | | | | | | | | | | | | | | | | | | | | | | | | | | | | |
| RBUF | 776502 | Transmitter | 304 | | | | | | | | | | | | | | | | | | | | | | | | | | | | | | | | | | | | | | | |
| XCSR | 776504 | | | | | | | | | | | | | | | | | | | | | | | | | | | | | | | | | | | | | | | | | |
| XBUF | 776506 | | | | | | | | | | | | | | | | | | | | | | | | | | | | | | | | | | | | | | | | | |
| Device Addresses | | Interrupt Vectors | | | | | | | | | | | | | | | | | | | | | | | | | | | | | | | | | | | | | | | | |
| RCSR | 776540 | Receiver | 340 | | | | | | | | | | | | | | | | | | | | | | | | | | | | | | | | | | | | | | | |
| RBUF | 776542 | Transmitter | 344 | | | | | | | | | | | | | | | | | | | | | | | | | | | | | | | | | | | | | | | |
| XCSR | 776544 | | | | | | | | | | | | | | | | | | | | | | | | | | | | | | | | | | | | | | | | | |
| XBUF | 776546 | | | | | | | | | | | | | | | | | | | | | | | | | | | | | | | | | | | | | | | | | |
| J11 | LTC ENBJ L | When grounded, this signal sets the line clock interrupt enable flip-flop and allows the LSI-11 bus BEVNT signal to request program interrupts. | | | | | | | | | | | | | | | | | | | | | | | | | | | | | | | | | | | | | | | | |

Boot/Diagnostic ROM

Two jumpers and one eight-switch DIP pack (E102) on the KDF11-B module provide a selection of bootstrap and diagnostic programs for hard disks. They also allow for the customer's own bootstrap programs if diagnostic/bootstrap ROMs are installed in sockets E126 and E127. Refer to Figure 8-3 for location of E126 and E127. The switch and jumper functions are described in Tables 8-3 through 8-5. Table 8-6 lists the jumper configurations when using ROMs or EPROMs.

Table 8-3 Diagnostic/Bootstrap Program Selection

| CDAL Bit | Switch Number | Switch Position | Function |
|----------|---------------|-----------------|--|
| 00 | S1-1 | ON | Execute CPU diagnostic upon power-up or restart. |
| 01 | S1-2 | ON | Execute memory diagnostic upon power-up or restart. |
| 02 | S1-3 | ON | DECnet boot (S1-4 through S1-7 are arguments). |
| 03 | S1-4 | ON | Console test and dialogue (S1-3 OFF). |
| 03 | S1-4 | OFF | Turnkey boot dispatched by S1-5 through S1-8 configuration (S1-3 OFF). |

Table 8-4 Diagnostic/Bootstrap Program Switch Position

| Boot Device** | Switch Positions | | | |
|---------------|------------------|------|------|------|
| | S1-4 | S1-5 | S1-6 | S1-7 |
| DUV11 | ON | X | X | X |
| DLV11-E | OFF | ON | X | OFF |
| DLV11-F | OFF | ON | X | ON |

** DLV11-E CSR - 775610
 DLV11-F CSR - 776500
 DUV11 CSR - 760040 if no devices from 760010 to 760038

X - don't care

Table 8-5 Bootstrap Program Selection

| Device Mnemonic | Switches CDAL Bit | S1-5 04 | S1-6 05 | S1-7 06 | S1-8 07 | Program Selected |
|-----------------|-------------------|---------|---------|---------|---------|---------------------------|
| DKn:n<:8* | | OFF | OFF | OFF | ON | RK0b Boot |
| DLn:n<:4 | | OFF | OFF | ON | OFF | RL01 or RL02 Boot |
| DDn:n<:2 | | OFF | OFF | ON | ON | TU68 (SLU) at //8500 Boot |
| DXn:n<:2 | | OFF | ON | OFF | OFF | RX01 Boot |
| DYn:n<:2 | | OFF | ON | ON | OFF | RX02 Boot |

*n = unit number

Table 8-6 ROM - EPROM Jumpers

| Jumper From | To | Memory ROM | Type EPROM | Function |
|-------------|-----|------------|------------|--|
| J24 | J23 | I* | R† | Connects BTRA 13 H to pin 21 of the two ROM sockets. |
| J22 | J23 | R | I | Connects + 6 V to pin 21 of the two ROM sockets. |

*I = installed; R = removed

Table 8-8 Character Format Jumpers

| Stake Number | Stake Name | Function |
|--------------------|------------|---|
| Console SLU | | |
| J38 | Ground | This wire-wrap stake provides a ground source for the other four wire-wrap stakes in this group. |
| J39 | DL1 CH7J L | When grounded, this signal causes the UART to transmit and receive 7-bit characters. Otherwise, the UART is formatted for 8-bit characters. |
| J37 | DL1 ST1J L | When grounded, this signal causes the UART to transmit and receive one stop bit. Otherwise, it is formatted for two stop bits. |
| J36 | DL1 PARJ L | When grounded, this signal enables UART parity generation and checking. Otherwise, parity is disabled. |
| J40 | DL1 ODDJ L | When DL1 PARJ L and DL1 ODDJ L are both grounded, odd parity is selected. If only DL1 PARJ L is grounded, even parity is selected. |
| Second SLU | | |
| J30 | Ground | This wire-wrap stake provides a ground source for the other four wire-wrap stakes in this group. |
| J31 | DL2 CH7J L | When grounded, this signal causes the UART to transmit and receive 7-bit characters. Otherwise, the UART is formatted for 8-bit characters. |
| J29 | DL2 ST1J L | When grounded, this signal causes the UART to transmit and receive one stop bit. Otherwise, it is formatted for two stop bits. |
| J28 | DL2 PARJ L | When grounded, this signal enables UART parity generation and checking. Otherwise, parity is disabled. |
| J32 | DL2 ODDJ L | When DL2 PARJ L and DL2 ODDJ L are both grounded, odd parity is selected. If only DL2 PARJ L is grounded, even parity is selected. |

Table 8-9 Character Jumper Configuration

| Jumper | From | To GND | Character Format Option |
|--------------------|------|--------|--------------------------|
| Console SLU | | | |
| J31 | IN | | 7-bit characters |
| | OUT | | 8-bit characters |
| J29 | OUT | | Two stop bits |
| | IN | | One stop bit |
| J28 | IN | | Parity check enabled |
| | OUT | | Parity check disabled |
| J32 | IN | | Odd parity if J28 is in |
| | OUT | | Even parity if J28 is in |
| Second SLU | | | |
| J39 | IN | | 7-bit characters |
| | OUT | | 8-bit characters |
| J37 | OUT | | Two stop bits |
| | IN | | One stop bit |
| J38* | IN | | Parity check enabled |
| | OUT | | Parity check disabled |
| J40 | IN | | Odd parity if J38 is in |
| | OUT | | Even parity if J38 is in |

*If 8-bit characters (J39 OUT) are selected, parity check must be disabled (J38 OUT).

Break Halt – Two jumpers enable and disable the break halt feature. If this feature is enabled, the detection of a break condition by the console UART causes the processor to halt and enter the octal debugging technique microcode. When disabled, there is no response to the break condition. Table 8-10 describes the jumper configuration to select the break halt feature.

Internal/External SLU Clock Jumpers

Two sets of jumpers are provided to select an internal or external clock for the console SLU and the second SLU. When the internal clock jumpers are installed, the SLU clocks are obtained from the internal baud rate generator. When the external clock jumpers are installed, external clocks are routed to the SLUs through pin 1 of the J1 and J2 SLU connectors. Table 8-11 describes the internal/external SLU clock jumper configurations.

Table 8-10 Break Halt Jumper Configuration

| Jumper From | To | Function | Break Feature | |
|----------------|----|-------------------------------|---------------|----------|
| | | | Enabled | Disabled |
| J5 | J4 | Connects ground to RO HLT H | R* | I* |
| J3 | J4 | Connects DL1 FE H to RO HLT H | I | R |

*R = removed; I = installed

J3 - DL1 FE H

J4 - RO HLT H

J5 - Ground

Table 8-11 Internal/External SLU Clock Jumper Configuration

| Jumper From | To | Function | Selected Clock | |
|----------------|-----|--|----------------|----------|
| | | | Internal | External |
| J43 | J42 | Connects internal baud rate generator to the console SLU UART. Normal configuration. | I | R |
| J41 | J42 | Connects external clock to the console SLU UART. | R | I |
| J48 | J45 | Connects internal baud rate generator to the second SLU UART. Normal configuration. | I | R |
| J44 | J45 | Connects external clock to the second SLU UART. | R | I |

Test Jumpers

Two types of test jumpers are used for tests performed by manufacturing and field service. Tables 8-12 and 8-13 describe these test jumpers and their functions.

MEMORY EXPANSION

The KDF11-B processor is capable of handling up to 512K bytes of address space. This microprocessor is factory configured with 256K or 512K bytes of memory depending on the memory option chosen for a basic PDP-11/23-PLUS system. Chapter 5 presents factory configuration for the basic system.

Additional MSV11-P (M8067) memory modules are available for system expansion. Each memory module, when added to a PDP-11/23-PLUS system, requires reconfiguration. This is accomplished by repositioning jumpers on the MSV11-P module wire-wrap stakes. The guidelines for memory reconfiguration are presented in the following paragraphs and explained in detail in the *MSV11-P User's Guide*.

Table 8-12 Manufacturing Test Jumpers

| Jumper | | Function |
|--------|-----|---|
| From | To | |
| J6 | J7 | Connects the system oscillator to the CPU and LSI-11 bus timing circuits. |
| J8 | J9 | Connects the PHASE signal to the input of the F11 chip clock drivers. |
| J20 | J21 | Connects the baud rate crystal oscillator to the SLU baud rate generator and the -12 V charge pump circuit. |

Table 8-13 Field Service Test Jumpers

| Jumper | | Function | Field Service | Normal Operation |
|--------|-----|--|---------------|------------------|
| From | To | | | |
| J27 | J26 | Connects the output of the console serial line driver to the console serial output line. | R* | I* |
| J25 | J26 | Connects the serial line input from the console connector to the console connector serial line output. | I | R |

*R = removed; I = installed

Configuring the MSV11-P

The jumpers on the MSV11-P memory module are divided into five groups.

- Starting Address
- Control and Status Register (CSR) Address
- Power
- Bus Grant Continuity
- General

Figure 8-4 illustrates the five jumper groups. Four jumper groups are enclosed in solid boxes and labeled; the remaining jumpers are classified as general jumpers and are enclosed in dotted boxes. Table 8-6 lists the jumpers and their functions for factory configured memories.

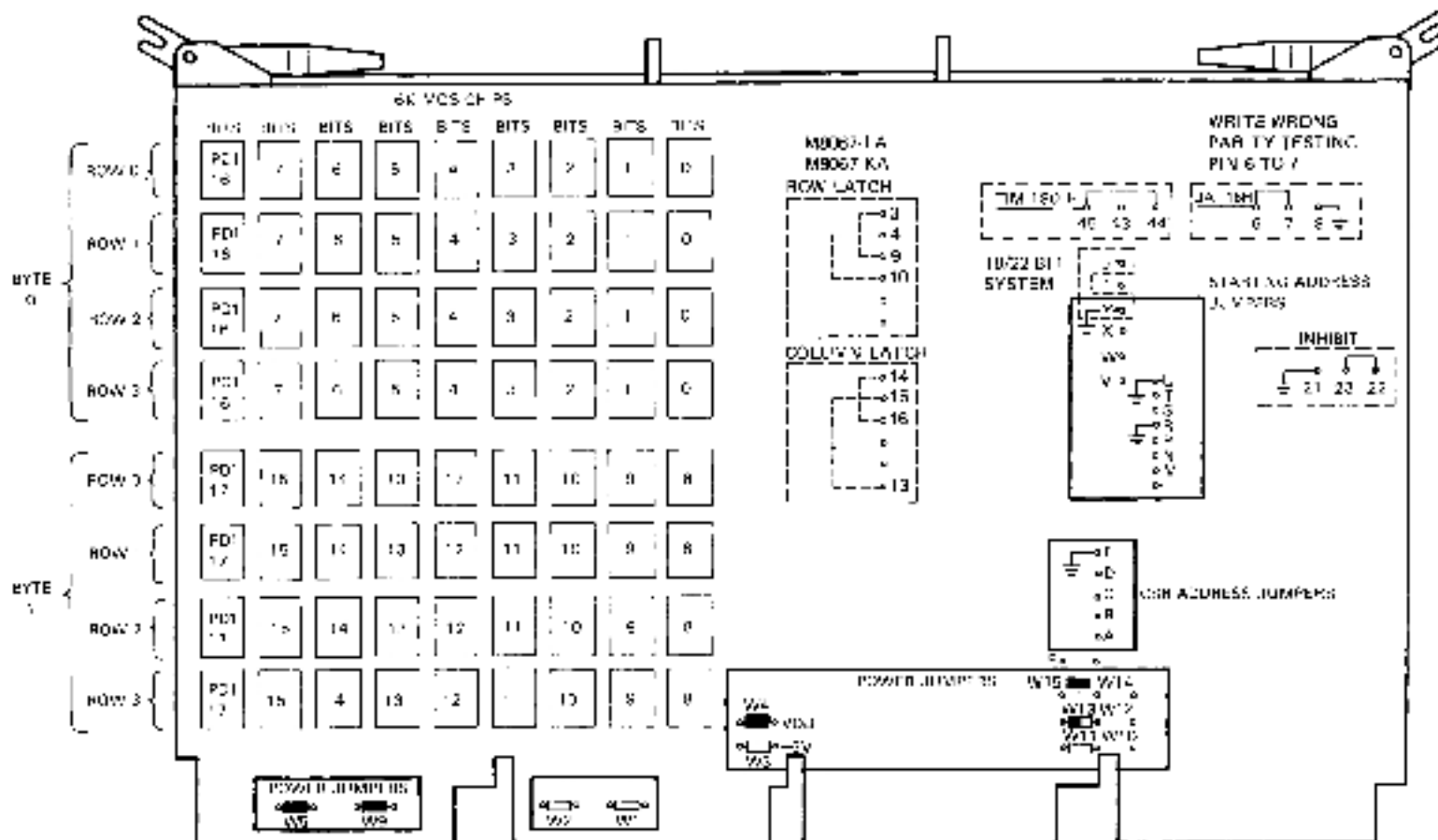

64K SINGLE VOLTAGE DEVICES

NON-BAT BACKUP

- W4
- W5
- W9
- W13/W15

BAT BACKUP

- W4
- W5
- W12
- W14

VOLTAGES

- DECOUPLE -6
- DECOUPLE -5
- +5 CK
- +5 VDD

GRANT CONTINUITY
 W1 AND W2 -5 FOR
 Q01 MACH 1, Q22, Q23
 MACHINE
 W1 AND W2 OUT FOR
 Q03 AND Q22 Q11 MACHINE

POWER JUMPERS

WITH BATTERY BACKUP

- POWER JUMPER IN FOR BAT CHIPS
- POWER JUMPER IN FOR BPT 15K-16K CHIPS

Figure 8-4 MSV11-P Jumper Locations

Starting Address - To determine the starting address, you must first know the system's memory capacity before replacing the module. Change the byte value (total memory of the system) to a word value (1/2 the byte value). This word value is the module starting address (MSA). This address is divided into two groups, the first address of the range (FAR) and the partial starting address (PSA). Table 8-14 is used to determine the FAR and PSA values.

Find the FAR value - This is done by looking at Table 8-14, Part 1 and locating the address range in which the MSA falls. The FAR value is the first address of the selected address range. A specific configuration of jumper pins (X, W, and V) that use jumper pin Y (a ground pin) is associated with the FAR value.

Find the PSA value - This is done by inserting the MSA and FAR values into the equation $PSA = MSA - FAR$. After you do the subtraction, locate the PSA value on Table 8-14, Part 2. A specific configuration of jumper pins (P, N, M, L, and T) that use jumper pin R (a ground pin) is associated with the PSA.

The following example shows how to use the equation to jumper a module.

The system has 512K bytes of memory. To jumper the memory module, change this byte value (512K) to a word value (256K). This word value is called the MSA.

Insert this value into the equation.

$$PSA = MSA - FAR$$

$$PSA = 256K - FAR$$

To find the value of FAR use Table 8-14, Part 1 to locate the address range in which the MSA value falls. Take the first address of the address range and insert it into the equation.

$$PSA = MSA - FAR$$

$$PSA = 256K - 256K$$

$$PSA = 0K$$

Use Table 8-14, Part 1 - The FAR value equals 256K; this means wire-wrap pins V to Y.

Use Table 8-14, Part 2 - The PSA value equals 0K; this means no wire-wraps on pins P, N, M, L, and T.

Table 8-14 Starting Address Configuration (Part 1)

First Address Ranges (FAR) Jumpers to Ground (Pin Y)

| Decimal K Words | Octal K Words | Pin X (A21) | Pin W (A20) | Pin V (A19) |
|-----------------|-------------------|-------------|-------------|-------------|
| 000-248 | 00000000-01740000 | OUT | OUT | OUT |
| 256-504 | 02000000-03740000 | OUT | OUT | IN |
| 512-760 | 04000000-05740000 | OUT | IN | OUT |
| 768-1016 | 06000000-07740000 | OUT | IN | IN |
| 1024-1272 | 10000000-11740000 | IN | OUT | OUT |
| 1280-1528 | 12000000-13740000 | IN | OUT | IN |
| 1528-1784 | 14000000-15740000 | IN | IN | OUT |
| 1742-2040 | 16000000-17740000 | IN | IN | IN |

Table 8-14 Starting Address Configuration (Part 2)

Partial-Starting Address (PSA)

Jumpers to Ground (Pin R)

| Decimal K Words | Octal K Words | Pin P (A18) | Pin N (A17) | Pin M (A16) | Pin L (A15) | Pin T (A14) |
|-----------------|---------------|-------------|-------------|-------------|-------------|-------------|
| 0 | 00000000 | OUT | OUT | OUT | OUT | OUT |
| 8 | 00040000 | OUT | OUT | OUT | OUT | IN |
| 16 | 00100000 | OUT | OUT | OUT | IN | OUT |
| 24 | 00140000 | OUT | OUT | OUT | IN | IN |
| 32 | 00200000 | OUT | OUT | IN | OUT | OUT |
| 40 | 00240000 | OUT | OUT | IN | OUT | IN |
| 48 | 00300000 | OUT | OUT | IN | IN | OUT |
| 56 | 00340000 | OUT | OUT | IN | IN | IN |
| 64 | 00400000 | OUT | IN | OUT | OUT | OUT |
| 72 | 00440000 | OUT | IN | OUT | OUT | IN |
| 80 | 00500000 | OUT | IN | OUT | IN | OUT |
| 88 | 00540000 | OUT | IN | OUT | IN | IN |
| 96 | 00600000 | OUT | IN | IN | OUT | OUT |
| 104 | 00640000 | OUT | IN | IN | OUT | IN |
| 112 | 00700000 | OUT | IN | IN | IN | OUT |
| 120 | 00740000 | OUT | IN | IN | IN | IN |
| 128 | 01000000 | IN | OUT | OUT | OUT | OUT |
| 136 | 01040000 | IN | OUT | OUT | OUT | IN |
| 144 | 01100000 | IN | OUT | OUT | IN | OUT |
| 152 | 01140000 | IN | OUT | OUT | IN | IN |
| 160 | 01200000 | IN | OUT | IN | OUT | OUT |
| 168 | 01240000 | IN | OUT | IN | OUT | IN |
| 176 | 01300000 | IN | OUT | IN | IN | OUT |
| 184 | 01340000 | IN | OUT | IN | IN | IN |
| 192 | 01400000 | IN | IN | OUT | OUT | OUT |
| 200 | 01440000 | IN | IN | OUT | OUT | IN |
| 208 | 01500000 | IN | IN | OUT | IN | OUT |
| 216 | 01540000 | IN | IN | OUT | IN | IN |
| 224 | 01600000 | IN | IN | IN | OUT | OUT |
| 232 | 01640000 | IN | IN | IN | OUT | IN |
| 240 | 01700000 | IN | IN | IN | IN | OUT |
| 248 | 01740000 | IN | IN | IN | IN | IN |

Control and Status Register (CSR) Address – Each MSV1 1-P CSR is assigned to one of the 16 addresses shown in Figure 8-5 and Table 8-15. CSR addresses are assigned as follows.

1. Determine how many memory modules in your system have CSR registers.
2. List the memory modules sequential position from the CPU.
3. The memory modules closest to the CPU have the lower module starting address (MSA).
4. The memory module with the lowest MSA is assigned to the lowest CSR address and jumpered according to Table 8-15.
5. The next sequential CSR memory module is assigned the next higher CSR address.

Each memory module has four CSR jumper pins (A, B, C, and D) which can be daisy chained to pin E, the ground pin. The jumpers allow logic to detect a specific CSR address that has been assigned to a CSR memory module.

For example, assume the system has two memory modules with CSR registers. You are installing the third CSR memory. Refer to Table 8-15 and find the column labeled module number three. The CSR jumper pin configuration is pin B wire-wrapped to pin E. The memory module's CSR address is 17772104 for large systems or 772104 for small systems.

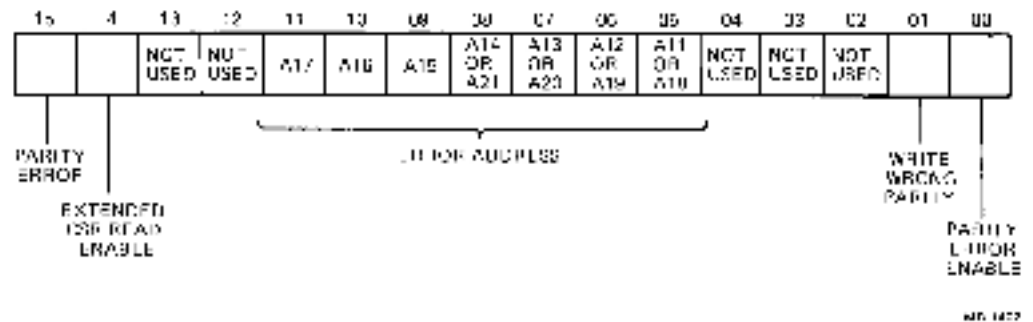

Figure 8-5 CSR Bit Allocation

Table 8-15 CSR Address Selection

| Module Number | Large System LSI-11 Bus Address | Small System LSI-11 Bus Address | Jumper to Ground (Pin E) | | | |
|---------------|---------------------------------|---------------------------------|--------------------------|-----|-----|-----|
| | | | D | C | B | A |
| 1 | 17772100 | 772100 | OUT | OUT | OUT | OUT |
| 2 | 17772102 | 772102 | OUT | OUT | OUT | IN |
| 3 | 17772104 | 772104 | OUT | OUT | IN | OUT |
| 4 | 17772106 | 772106 | OUT | OUT | IN | IN |
| 5 | 17772110 | 772110 | OUT | IN | OUT | OUT |
| 6 | 17772112 | 772112 | OUT | IN | OUT | IN |
| 7 | 17772114 | 772114 | OUT | IN | IN | OUT |
| 8 | 17772116 | 772116 | OUT | IN | IN | IN |
| 9 | 17772120 | 772120 | IN | OUT | OUT | OUT |
| 10 | 17772122 | 772122 | IN | OUT | OUT | IN |
| 11 | 17772124 | 772124 | IN | OUT | IN | OUT |
| 12 | 17772126 | 772126 | IN | OUT | IN | IN |
| 13 | 17772130 | 772130 | IN | IN | OUT | OUT |
| 14 | 17772132 | 772132 | IN | IN | OUT | OUT |
| 16 | 17772134 | 772134 | IN | IN | IN | OUT |
| 16 | 17772136 | 772136 | IN | IN | IN | IN |

Power – All possible power configurations are shown in Figure 8-4.

Bus Grant Continuity – These jumpers are removed for systems using an H9276 backplane.

General Jumpers – All remaining jumpers and their functions are listed in Table 8-16.

MASS STORAGE DISK EXPANSION

The RLV12 disk controller is capable of handling up to four RLD2 disk drives. Each additional disk drive provides 10.40 million bytes of data storage. An additional cabinet is required for adding an additional mass storage disk.

CABINET EXPANSION

An additional cabinet can be ordered to attach to the present cabinet; or a new, completely assembled cabinet with its own power controller can be ordered. Refer to Table 8-17 for the module and description of the expansion cabinet desired.

Table 8-16 General Jumpers

| Pin Numbers | Function |
|--------------------|---|
| 8 to 7 | In - write wrong parity. |
| 8 to 7 | In - disables wrong parity. |
| 2 to Y | 2 to Y out - 22-bit machine. 2 to Y in - 16 bit machine. |
| 43 to 44 | In - single voltage MOS RAM access time (150 ns device). |
| 45 to 44 | In - multiple voltage MOS RAM access time (200 ns device). |
| 22 to 23 | Not used. |
| 21 to 23 | Not used. |
| F to H | F to H in - connected to force starting address to 16K F to H out - disables force function. |
| 8 to 9 | 3 to 9 in - connected on 16K and 64K MOS chip. |
| 13 to 15 | Connected on 16K and 64K MOS chip. |
| 4 to 10 | Connected only on 64K MOS chip. |
| 14 to 16 | Connected only on 64K MOS chip. |

Table 8-17 PDP-11/23-PLUS Expansion Cabinets

| Model | Description |
|--------------|---|
| H9542-AA | Left-hand top-loading RL02 cabinet with no power controller. |
| H8542-AB | Right-hand top-loading RL02 cabinet with no power controller. |
| H9542-AA | Left-hand solid-top cabinet with no power controller. |
| H9542-AB | Right-hand solid-top cabinet with no power controller. |

Removal of Cabinet Side Panels

Proceed as follows to remove the side panels.

1. Remove the rear panel (see Figure 8-6).
2. From the rear of the top RL02 disk drive, remove the two screws that prevent the drive from being extended on its chassis slides, from the shipping bracket.
3. Pull out the stabilizer foot at the base of the system cabinet.
4. Slide the top RL02 out to extend in front of the cabinet.
5. Pull the side panel up and out, as shown (arrow) in Figure 8-6.

To replace the panel, simply position the side panel so that the top edge of the panel extends approximately 7.62 cm (3 in) above the top edge of the cabinet. Line up the slotted groove brackets located approximately 25.4 cm (10 in) from the bottom of the cabinet with the extended bracket on the side panel. Slide the panel down on the brackets until the top edge of the panel is flush with the top of the cabinet.

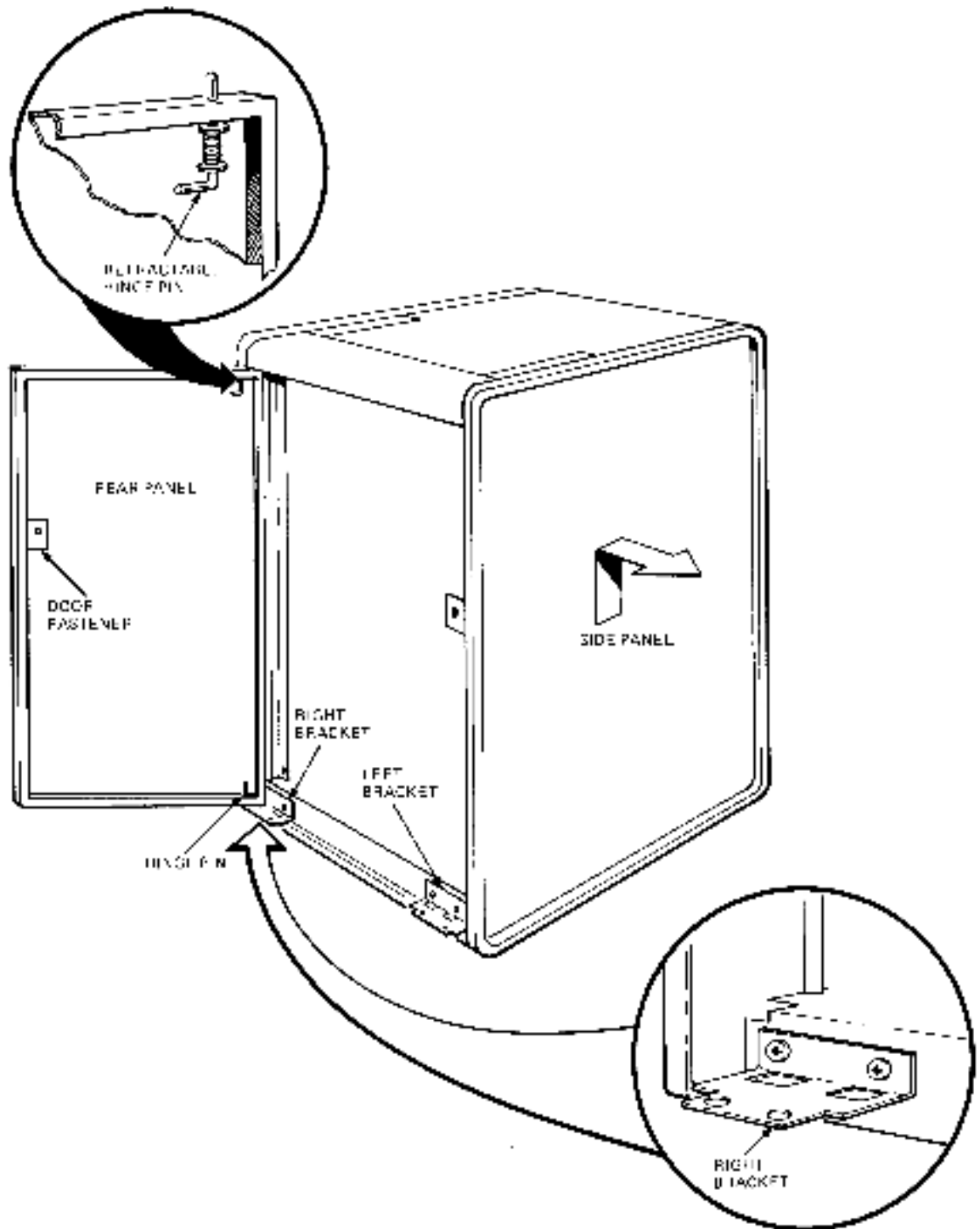

99-300

Figure 8-6 Left and Right Side Panel Removal

APPENDIX A RELATED DOCUMENTATION

HARDWARE DOCUMENTATION

| Title | Part Number | Medium |
|--|-------------|---------------------------------|
| KDF11 B User's Guide | EK-KDFEB-UG | Hardcopy |
| Microcomputer Handbook Series | | |
| Microcomputer and Memories | EB-18451-20 | Handbook * |
| Microcomputer Interfaces | EB-17723-20 | Handbook * |
| RL02 Disk Drive User's Guide | EK-ORL02-UG | Hardcopy * |
| RL02 Disk Drive Technical Description | EP-ORL02-TD | Microfiche |
| RL021 Disk Subsystem Service Manual | EP-ORL02-SV | Microfiche |
| RLV12 Disk Controller User's Guide | EK-RLV12-UG | Hardcopy |
| DLV11-J User's Guide | EK-DLV1J-UG | Hardcopy * |
| MSV11-P User's Manual | EK-MSVOP-UG | Hardcopy * |
| PDP-11/2B Mounting Box Technical Manual | EK-1123B-TM | Hardcopy * and Microfiche |
| LA120 User's Guide | EK-LA120-UG | Hardcopy * |
| VT100 Video Terminal User's Guide | EK-VT100-UG | Hardcopy * |
| VT102 Video Terminal User's Guide | EK-VT102-UG | Hardcopy * |

*These documents can be ordered from:

Digital Equipment Corporation
Accessories and Supplies Group
P.O. Box CS 2008
Nashua, NH 03061

For information concerning microfiche libraries, contact:

Digital Equipment Corporation
 Microfiche Distribution (MDS)
 Bedford, MA 01730

DIAGNOSTIC SOFTWARE

| Title | Part Number | Medium |
|--------------------------------|--------------------|---------------|
| XXDP+ / SUPR User's Manual | AC-F348A-MC | Hardcopy |
| DEC/X11 User's Manual | AC-F053-MC | Hardcopy |
| DEC/X11 Cross Reference Manual | AC-F055-MC | Hardcopy |
| RSTS/E System User's Manual | AA-5133B-TC | Hardcopy |

For further information on diagnostic software and the medium desired, refer to the *PDP-11 Diagnostic Software Components Catalogue*, AV-B021E-TC. To order these documents, see your DIGITAL sales representative.

SYSTEM SOFTWARE

| Title | Part Number | Medium |
|-------------------------------|--------------------|---------------|
| Introduction to RT-11 | DEC-11-ORITA-A-D | Hardcopy |
| RT-11 Documentation Directory | DEC-11-ORDDA-A-D | Hardcopy |
| RT-11 System User's Guide | DEC-11-ORGDA-A-D | Hardcopy |

To order these documents, see your DIGITAL sales representative.

APPENDIX B PDP-11/23-PLUS GLOSSARY

Acoustic Coupler – A modem that converts data into a sequence of different tones to be transmitted via a conventional telephone.

ANSI – Acronym for American National Standards Institute.

Answerback – A preprogrammed response from a terminal.

ASCII – Acronym for American Standard Code for Information Interchange. A 7- or 8-bit standard code to transmit data for data processing.

Backplane – The back part of the box that contains the bus into which all options are connected.

B-Event – An external bus event that interrupts the processor's normal routine.

Bootstrap – A program used to load the instructions of a program into storage.

Buffer Control – A temporary storage memory used to equalize different operating speeds.

Bus Error Trap – A high-priority interrupt that halts the processor routine and initiates a subroutine.

Byte – A group of binary bits used to encode a single character.

CCC Chain – A process of linking a series of programs to operate together.

Character Set – Contains the numbers, letters, and symbols associated with a given device or coding system.

Control Panel – The portion of the processor that contains the control switches and indicators.

CPU – Acronym for Central Processing Unit.

Diagnostic Program – A program designed to locate a malfunction in the central processing unit or in a peripheral device.

Directory – A listing of diagnostic programs or utility programs.

Double Density – A recording scheme that allows magnetic floppy disks to increase their storage capability.

Double-Height Board – An option for LSI-11 systems that requires only two connectors on the backplane.

EIA Interface – A standard interface that is defined by the Electronic Industries Association (EIA).

Emulator – A type of device that allows the user to write a program on one computer system for use on a different computer system.

Error Message – A printed statement indicating the computer has detected a mistake or malfunction.

External LTC – An external line time clock used to interrupt the processor's normal routine.

Fill Characters – Nonprintable characters that are transmitted to occupy time while the terminal performs nonprintable functions.

Floating Point – A method of calculation that automatically moves the decimal point.

Instruction Set – A set of vendor-supplied operation codes for a particular computer.

Interlace Mode – The assignment of successive addresses to physically separated storage locations in such a way as to reduce the access time. Interlace mode causes the video processor to display 480 scan lines per frame, versus 240 scan lines in noninterlace mode. For high resolution equipment, such as a camera, there is no difference in character resolution. Interlace mode may cause the screen to flicker.

Interrupt Vector – An address that causes the hardware to transfer program control to some specific location.

LED – An acronym for Light Emitting Diode.

Line Wraparound – When the end of a line is reached on a video screen, the next character automatically prints at the beginning of the next line.

Memory Management – The organization, creation, and maintenance of memory so that needless data can be removed and valuable data preserved.

Modem – A telecommunications device that provides the appropriate interface between the computer and a communications link.

MOS – An acronym for **Metallic Oxide Semiconductor**.

Nonvolatile Memory – A storage media that returns its data in the absence of power.

ODT – An acronym for **on-line debugging technique**.

Oersted – A unit of magnetic field strength equal to the magnetic intensity one centimeter from a unit magnetic pole. Abbreviated: Oe.

Parity – An extra bit that is added to a byte character or word to ensure that there is always either an even or odd number of bits, according to the logic of the system.

Peripheral Device – An input/output unit or an auxiliary storage unit of a computer system.

Power Controller – A unit that receives ac power from a wall receptacle, monitors the power with a circuit breaker, and distributes that power to the computer system.

Program Monitor – An asterisk (*) that is printed to inform the user that the program is waiting for instructions.

Quad Module – An option for LSI-11 systems that requires four connectors on the backplane.

Queue Overflow – An overflow of items waiting to be acted upon by the computer.

Real Time – The computations of the computer are fast enough to sense the changes of input data that influence the output.

Reserved Instruction Trap – A nonprogrammed conditional jump to a specified location whenever a reserved instruction is initiated.

ROM – An acronym for **read-only memory**.

RL02 Controller – The interface module mounted in the backplane that transfers data between the CPU and the RL02.

Scrolling – The up or down movement of data on a video screen to allow for new data to be presented.

System Monitor – A period (.) that is printed to inform the user that the system is waiting for instructions.

Utility Program – A program used to perform some frequently required process in the operation of a computer.

PDP-11/23-PLUS INDEX

| | |
|----------------------------------|-----------|
| A | |
| AC Power Indicator..... | 3 |
| AUX ON/OFF Switch..... | 3 |
| B | |
| BA11-S Expander Box..... | 63,75 |
| BA11-S Mounting Box..... | 63 |
| Backpanel Expansion..... | 91-93 |
| Baud Rate Selection..... | 99 |
| Booting the System..... | 5 |
| Boottrap Technique..... | 5,39 |
| BREAK Key Function..... | 4 |
| C | |
| Cabinet Expansion..... | 108,109 |
| Cabinet Side Panels..... | 110 |
| Changing a Disk Cartridge..... | 8 |
| Configuration..... | 94 |
| PDP-11/23-PLUS System..... | 2,62,63 |
| 11/23 Subsystem..... | 62,63,94 |
| KDF11-B Microprocessor..... | 64,65 |
| MSV11-P Memory..... | 68,71,102 |
| DZV11..... | 70,72 |
| H9276 Backplane..... | 73,75 |
| RLV12 Disk Controller..... | 70,74 |
| Console Cabinet..... | 79,111 |
| Control Panel..... | 2,76 |
| Copying the Diagnostic Disk..... | 15 |
| D | |
| DEC/X11 Diagnostics..... | 11,17,56 |
| Error Messages..... | 56 |
| Restarting Programs..... | 52 |
| Diagnostic Directory..... | 12 |
| Diagnostic Programs..... | 11,58 |
| Diagnostic Flowchart..... | 38,39 |
| Disk Cartridges..... | 6 |
| Disk Cartridge Loading..... | 5,6 |
| Disk Drive Cables..... | 32 |

| | |
|------------------------------------|--------|
| Disk Drive Indicators | 4 |
| Disk Storage | 4 |
| Directory Listing | 12 |
| DLDP+ Programs | 12,52 |
| Error Messages | 52 |
| Restarting | 52 |
| Modifying Programs | 52 |
| Single Instruction | 54 |
| Expanding Chains | 54 |
| E | |
| Expansion | 91 |
| General | 91 |
| Memory | 102 |
| Mass Storage Disk | 108 |
| Cabinet | 108 |
| F | |
| FAULT Indicator | 4 |
| FDX/HDX Switch | 4 |
| Finding a Diagnostic Program | 12 |
| H | |
| HALT Switch | 2 |
| Help Message | 13, 14 |
| H403 Input Box | 73 |
| H7861 Power Supply | 73 |
| H349 Distribution Panel | 76 |
| I | |
| Installation Checklist | 3,27 |
| Initial System Start-up | 7 |
| L | |
| LA 120 Terminal | 81,83 |
| LINE/LOCAL | 79 |
| LOAD Indicator | 4 |
| Loading the Operating System | 7 |
| O | |
| ODT | 51 |
| P | |
| Processor Subsystem | 33,81 |
| Power Controller | 79 |
| Powering Down | 9 |
| Programming | 11 |
| PWR OK Indicator | 2 |
| PWR OK LED | 2 |

| | |
|---|------|
| R | |
| Receive Speed..... | 5 |
| RESTART Switch..... | 2.3 |
| RSX-11M and RSX-11M-PLUS Software | 16 |
| RSTS/E and CTS-500 Software | 20 |
| RUN LED | 2 |
| Running the Diagnostic Program | 14 |
| RL02 Disk Drive..... | 78 |
| RL02 Front Panel | 2 |
| S | |
| Stabilizer Foot | 29 |
| System..... | 1,30 |
| Cabling | 34 |
| Cooling..... | 90 |
| Cleanliness..... | 89 |
| Heat Dissipation | 89 |
| Radiated Emissions..... | 89 |
| Specifications..... | 88 |
| Static Electricity | 90 |
| Power | 87 |
| Start-Up..... | 7 |
| T | |
| Terminal Checkout..... | 40 |
| Transmit Speed..... | 5 |
| Troubleshooting | 36 |
| U | |
| UNIT SELECT Indicator..... | 4 |
| Unpacking Procedure..... | 27 |
| V | |
| VT100 Terminal..... | 82 |
| VT102 Terminal..... | 82 |
| W | |
| WRITE PROT Indicator | 4 |

Reader's Comments

PDP-11/23-PLUS System Manual
EK-1T23B-OP-001

Your comments and suggestions will help us in our continuous effort to improve the quality and usefulness of our publications.

What is your general reaction to this manual? In your judgement is it complete, accurate, well organized, well written, etc? Is it easy to use? _____

What features are most useful? _____

What faults or errors have you found in the manual? _____

Does this manual satisfy the need you think it was intended to satisfy? _____

Does it satisfy *your* needs? _____ Why? _____

Please send me the current copy of the *Technical Documentation Catalog*, which contains information on the remainder of DIGITAL's technical documentation.

Name _____ Street _____
Title _____ City _____
Company _____ State/Country _____
Department _____ Zip _____

Additional copies of this document are available from:

Digital Equipment Corporation
Accessories and Supplies Group
Cotton Road
Nashua, NH 03060

Attention *Documentation Products*
Telephone 1-800-258-1710

Order No. EK-1T23B-OP

Do Not Tear - Fold Here and Staple

digital



No Postage
Necessary
if Mailed in the
United States

BUSINESS REPLY MAIL
FIRST CLASS PERMIT NO 33 MAYNARD, MA

POSTAGE WILL BE PAID BY ADDRESSEE

Digital Equipment Corporation
Educational Services Development and Publishing
200 Forest Street (MR1-2/T17)
Marlboro, MA 01752



digital