

JULY 1981

# LCG LARGE COMPUTER GROUP

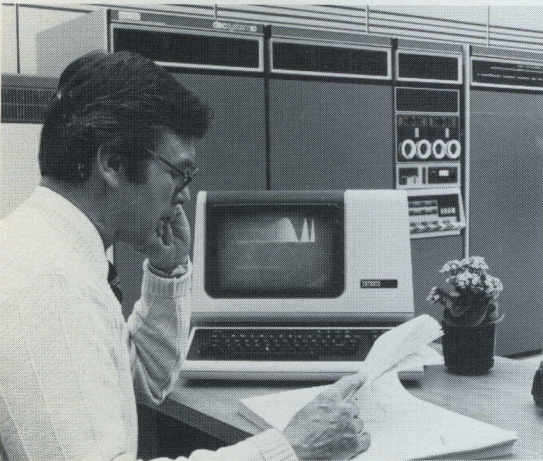
# PRODUCT SUMMARY



DECSYSTEM-2040



DECsystem-1090 SMP



DECsystem-1090



DECSYSTEM-2020



DECSYSTEM-2060



DECsystem-1091

digital

**LCG**  
**LARGE COMPUTER GROUP**

# **PRODUCT SUMMARY**

**digital**

DIGITAL EQUIPMENT CORPORATION

**The information in this document  
is subject to change without notice  
and should not be construed as a commitment  
by Digital Equipment Corporation. Digital  
Equipment Corporation assumes no responsibility  
for any errors that may appear in this summary.**

**DIGITAL, DEC, DECnet,  
MASSBUS, UNIBUS, TOPS-10,  
TOPS-20, DECsystem-10, and  
DECSYSTEM-20 are trademarks of  
Digital Equipment Corporation.**

**COPYRIGHT © 1981 DIGITAL EQUIPMENT CORPORATION**

**Forward Content/Format Comments To:  
LCG Product Summary  
MR1-2/E78**

# CONTENTS

## DECsystem-10

### DECsystem-1090 SYSTEM & OPTIONS

1090 Basic System Package.....	5
1090L License Only Package.....	5
1090 Symmetrical Multi-Processing (SMP).....	5
1090P to 1090 SMP Upgrades.....	5
Central Processor.....	6
Memory.....	6
Disk & Tape Controller.....	6
Add-on Disk Pack Drives.....	6
RP20 Series.....	6
Master Disk Subsystem.....	6
Add-On Disk Units.....	7
Options.....	7
TU77 Series.....	7
Magnetic Tape Subsystem.....	7
Add-On Magnetic Tape Drive.....	7
TU72 Series.....	7
Magnetic Tape Subsystem.....	7
Add-On Magnetic Tape Drive.....	7
Switch Options.....	7
Line Printers.....	8
LP100 Charabands.....	8
Card Equipment.....	9
Paper Tape.....	9
DN20 Front End Communications.....	9
Universal Front Ends.....	9
Synchronous Line Interfaces.....	9
Asynchronous Line Interfaces.....	10
DN200 Remote Station.....	10
DN200 Options.....	10
CPU Package Upgrades.....	11
Dual KI10 Upgrade.....	11

### 1090 CONFIGURATORS & RULES

DECsystem-1090-P Core Configurator.....	14
DN20 Configurator.....	15
TOPS-10 Networks and Decnet-10 Communications.....	15
IBM Communications.....	16
DN200 Configurator.....	17

### 1091 SYSTEM & OPTIONS

1091 Basic System Package.....	20
1091L License Only Package.....	20
MOS Memory.....	20
MF20 Memory Configurator.....	21
Disk & Tape Controller.....	21
Add-On Disk Pack Drives.....	21
RP20 Series.....	21
Master Disk Subsystem.....	21
Add-On Disk Units.....	21
Options.....	22
TU77 Series.....	22
Magnetic Tape Subsystem.....	22
Add-On Magnetic Tape Drive.....	22
TU72 Series.....	22
Magnetic Tape Controller.....	22
Add-On Magnetic Tape Drive.....	22
Switch Options.....	22
Line Printers.....	23

LP200 Charabands.....	23
Card Equipment .....	24
Paper Tape .....	24
I/O Bus Interface.....	24
Front End Communications .....	24
Asynchronous Line Interfaces .....	24
DN20 Front End Communications .....	24
Universal Front Ends.....	24
DN20 Front End Communications .....	25
Synchronous Line Interfaces .....	25
Asynchronous Line Interfaces .....	25
DN200 Remote Station.....	26
DN200 Options.....	26
Upgrades .....	26

**1091 CONFIGURATORS & RULES**

DECsystem-1091-S MOS Configurator.....	28
DN20 Configurator.....	29
TOPS-10 Networks and DECnet-10 Communications .....	29
IBM Communications .....	30
DN200 Configurator.....	31

**DECSYSTEM-20**

**DECSYSTEM-2020 SYSTEMS & OPTIONS**

2020 Basic System Packages.....	34
2020L License Only Packages .....	35
2020-J/K Special System Packages .....	36
MOS Memory .....	36
Add-on Disk Pack Drives .....	36
TAU77 Series .....	36
Magnetic Tape Subsystem.....	36
Add-On Magnetic Tape Drive .....	37
Line Printers.....	37
Card Equipment .....	37
Communication Equipment.....	38
Asynchronous Line Multiplexers .....	38
Synchronous Line Interfaces.....	38
2780/3780/HASP Communications for TOPS-20 Only .....	38
DN200 Remote Station for TOPS-10 Only .....	38
DN200 Options.....	38

**2020 CONFIGURATORS & RULES**

DECSYSTEM-2020 Configurator .....	42
DN22 Configurator.....	42

**DECSYSTEM-2040/2060 SYSTEMS & OPTIONS**

2040 Basic System Package.....	44
2040L License Only Package .....	44
2060 Basic System Package.....	44
2060L License Only Package .....	44
MOS Memory .....	44
MF20 Memory Configurator.....	45
Disk & Tape Controller .....	45
Add-On Disk Pack Drives .....	45
RP20 Series .....	45
Master Disk Subsystem .....	45
Add-On Disk Units.....	45
Options .....	46

TU77 Series .....	46
Magnetic Tape Subsystem.....	46
Add-On Magnetic Tape Drive.....	46
TU72 Series .....	46
Magnetic Tape Controller .....	46
Add-On Magnetic Tape Drives .....	46
Switch Options.....	46
Line Printers.....	47
LP200 Charabands.....	47
Card Equipment .....	48
Paper Tape .....	48
I/O Bus Interface.....	48
Front End Communications .....	48
Asynchronous Line Interfaces .....	48
DN20 Front End Communications .....	48
Universal Front Ends.....	48
Synchronous Line Interfaces .....	49
DN200 Remote Station.....	49
DN200 Options.....	49
DECSYSTEM-20 Upgrades .....	50
DECSYSTEM-20 Memory Guidelines.....	50
System Memory Guidelines .....	50
Memory Expansion/Exchange Guidelines .....	50

#### 2040/2060 CONFIGURATORS & RULES

DECSYSTEM-2040/2060 Configurator .....	52
DECSYSTEM-20 Configuration Guidelines .....	53
DN20 Universal Communications Front End Configurator .....	54
DECnet-20 Communications .....	54
Synchronous Option Types.....	54
IBM Communications .....	56
DN200 Configurator.....	57

### TERMINALS

#### TOPS-10/TOPS-20 SOFTWARE

#### HOW TO ORDER SOFTWARE & SERVICES

Software Order Number Format.....	62
-----------------------------------	----

#### OPTIONAL SOFTWARE PACKAGES

Sources.....	64
1090 Symmetrical Multi-Processing (SMP).....	64
Communications Software (Supported) .....	64
Languages and Data Management (Supported) .....	65
License Upgrades .....	66
Support Services .....	66
Miscellaneous Unsupported Software.....	66
Sources (Unsupported).....	66
Microcode and Diagnostics (Unsupported).....	67
Product Line Specific 10/20 Languages .....	67

#### ADDITIONAL EQUIPMENT AND INFORMATION

DC20, DN20, and DZ11 Communications Cabling .....	70
Cable Specifications .....	71
RTP20 Disk System Configurations.....	73
TU72 Series Magnetic Tape Configurations.....	77
Miscellaneous Options.....	83
Synchronous Line Options for DN87 .....	84
Asynchronous Line Options for DN87 .....	84

## FIGURES

<b>Figure 1</b> RTP20 Single-Port Configuration .....	75
<b>Figure 2</b> RTP20 Dual-Port Configuration.....	75
<b>Figure 3</b> RTP20 Dual-Channel, Single-Port Configuration.....	76
<b>Figure 4</b> RTP20 Dual-Channel, Dual-Port Configuration .....	76
<b>Figure 5</b> Single-Channel Configuration TX02-E Plus Tape Drives .....	78
<b>Figure 6</b> Dual-Channel Configuration TX02-E Plus TX03-E and Tape Drives .....	78
<b>Figure 7</b> Single-Channel Extended Configuration 2X02-E Plus TX05-E and Tape Drives .....	79
<b>Figure 8</b> Dual-Channel Two-Control Unit Configuration Two TX02-Es Plus Optional TX03-F and Tape Drives.....	80
<b>Figure 9</b> Two-Channel Dual-Control Unit Configuration Two TX02-Es Plus TX05-F and Tape Drives.....	81
<b>Figure 10</b> Dual-Channel Dual-Control Unit Configuration Two TX02-Es Plus TX03-F Plus TX05-F and Tape Drives.....	82
<b>INDEX</b> .....	85

## **INTRODUCTION**

This product summary gives you a concise description of DECsystem-10 and DECSYSTEM-20 systems, options, configurators, and their rules.

The catalog is divided into five major sections:

1. DECsystem-10 System Packages, Add-on Equipment, Configurators, Rules and Upgrade Information
2. DECSYSTEM-20 System Packages, Add-on Equipment, Configurators, Rules and Upgrade Information
3. Terminals
4. Software
5. Additional Equipment and Information

# **DECsystem-1090 System & Options**

## 1090 BASIC SYSTEM PACKAGE

- KL10-D Central Processor with Cache Memory
- 256K word MH10 Memory
- RH20 (for disk)
- One RP06-B Disk
- LA120 Console Terminal
- DN20 with 16 Asynchronous Lines
- Initial Support Package
- TOPS-10 Operating System (with TOPS-10 License)
- TOPS-10 Sources (Front End (RSX-20F) Sources are not included)

## INITIAL SUPPORT PACKAGE

- Ten training credits
- Hardware installation with 90-day warranty
- Software installation with 90-day warranty
- One set of Software Notebooks and 90 days update service
- Five sets of manuals (for the Operating System)

**A minimum system must include, in addition to the basic system package, a magnetic tape subsystem with a 1600 bit per inch, 9-track tape transport and a line printer.**

## BASIC SYSTEM PACKAGES

1090-PC      Basic System Package with Initial Support Package.  
1090-PD

## LICENSE ONLY PACKAGES *(Purchases of License Only Packages require a prerequisite of at least one fully supported Basic System Package.)*

1090L-PC      License Only Package  
1090L-PD      PREREQUISITE: 1090 Basic System Package

## 1090 SYMMETRICAL MULTI-PROCESSING (SMP): 1090P to 1090 SMP Upgrades

TOPS-10 DPE (Dual Processor Extension) Version 7.01 provides Symmetrical Multi-Processing (SMP) features for dual KL10 central processors. SMP provides the capability for attaching and sharing both memory and I/O devices between the central processors in a symmetric dual (master/master) configuration. The basic SMP product is software which provides a single reentrant copy of the monitor. The SMP product is an extension of the TOPS-10 Operating System. The hardware remains the same as with the older master/slave configurations (i.e., DECsystem-1099). Refer to the TOPS-10 DPE SPD (SPD 7.9) for software description.

**7.01 SMP (Symmetrical Multi-Processing) Customer Qualification Acknowledgement** form must be signed and a copy must accompany M.O.F. before Order Processing will log customer orders for the following options. The original copy should be forwarded to Customer Service Systems Engineering (CSSE) in Marlboro at MR1-1/S35. The Customer Qualification Acknowledgement form may also be obtained from CSSE.

1090S-UE	QH302-Xx
1090S-UF	M9301-WA
1090S-UG	M9301-WB
1090S-UH	

## 1090L LICENSE ONLY PACKAGE

- KL10-D Central Processor with Cache Memory
- 256K word MH10 Memory
- RH20 (for disk)
- One RP06-B Disk
- LA120 Console Terminal
- DN20 with 16 Asynchronous Lines
- Hardware installation with 90-day warranty
- TOPS-10 Operating System License

**A minimum system must include in addition to the license only package, a magnetic tape subsystem with a 1600 bit per inch 9-track tape transport and a line printer.**

- 1090S-UE  
1090S-UF      1090 "Model A" to 1090 SMP upgrade includes the KL10-D central processor (includes one RH20), KL10-PV CPU upgrade, QH302 SMP software features for TOPS-10, two (2) M9301 bootstraps (specify type), and an LA120 console terminal. (An RP06 must be provided separately for the KL10-D included in this package; it may be ordered as a separate line item or the customer may utilize an extra RP06 from his existing system.)  
*PREREQUISITE: 1090 "MODEL A"*
- 1090S-UG  
1090S-UH      1090 "Model B" to 1090 SMP Upgrade includes the KL10-D central processor (includes one RH20), TOPS-10 DPE (QH302) SMP software features for TOPS-10, two (2) M9301 bootstraps (specify type), and an LA120 console terminal. (An RP06 must be provided separately for the KL10-D included in this package; it may be ordered as a separate line item or the customer may utilize an extra RP06 from his existing system.)  
*PREREQUISITE: 1090 "MODEL B"*
- M9301-WA      SMP bootstrap for DN87S.
- M9301-WB      SMP bootstrap for DN20.
- QH302-Xx      TOPS-10 DPE SMP software features for TOPS-10.

### CENTRAL PROCESSOR

- KL10-FA  
KL10-FB      Add-on or upgrade central processor for the 1090 systems. Includes KL10D central processor (with one RH20 expandable up to eight RH20 controllers and three communication front ends), and an LA120 console terminal. Cables, software and the Initial Support Package are not included.

### MEMORY

- MH10-HA  
MH10-HB      128K word 1.2 microsecond memory module which includes 8 ports.  
*PREREQUISITE: KA10, KI10, KL10*
- MH10-LA  
MH10-LB      256K word 1.2 microsecond memory module (one MH10-H and two MH10-E's) which includes 8 ports.  
*PREREQUISITE: KA10, KI10, KL10*
- MH10-E      64K words expansion module which upgrades the MH10-HA to MH10-L.  
*PREREQUISITE: MH10-H*

### DISK & TAPE CONTROLLER

- RH20      MASSBUS controller for disks and tapes.  
*The 1090 system does not contain an RH20 for the tapes. It must be ordered separately.*

### RP06 ADD-ON DISK PACK DRIVES

- RP06-AA  
RP06-AB      Single access 176.0 megabyte add-on disk pack drive which includes one RP06-P disk pack.  
*PREREQUISITE: RH20*
- RP06-BA  
RP06-BB      Dual access 176.0 megabyte add-on disk pack drive which includes one RP06-P disk pack.  
*PREREQUISITE: RH20*
- RP06-C      RP06 dual access kit.  
*PREREQUISITE: RP06-A*

### RP20 SERIES

#### Master Disk Subsystem

- RTP20-EE  
RTP20-EF      967MB Fixed media disk master subsystem. Includes one RH20 and RP20 software.

**RP20 SERIES**  
**Add-On Disk Units**

RP20-AC      967MB Fixed media add-on disk unit TOPS-10 format.  
RP20-AD      *PREREQUISITE:* RTP20

**RP20 SERIES**  
**Options**

RTP20-EH      Dual channel option for RTP20 master subsystem.  
RTP20-EJ      *PREREQUISITE:* RTP20-EE/EF

RP20-CA      Dual port option for master subsystem.  
*PREREQUISITE:* RTP20

RP20-CB      Dual port option for add-on disk unit.  
*PREREQUISITE:* RP20-A

**NOTE**  
**RP20 CABLES**

All cables necessary to configure are supplied and are 20 feet long. Other lengths are available at additional charge. Consult the RTP20 Disk System Options Bulletin - Order No. ED 19725 26.

**TU77 SERIES**  
**Magnetic Tape Subsystem**

TU77-CB      Magnetic tape subsystem including a controller and one master tape drive 9-track, 125 inches per second, 800/1600 bits per inch (expandable to a maximum of four tape drives per controller with the addition of the TU77-AF(AJ) add-on tape drive).  
TU77-CD      *PREREQUISITE:* RH20

**TU77 SERIES**  
**Add-On Magnetic Tape Drive**

TU77-AF      9-track add-on magnetic tape drive 125 inches per second, 800/1600 bits per inch.  
TU77-AJ      *PREREQUISITE:* TU77-CB(CD)

**TU72 SERIES**  
**Magnetic Tape Subsystem**

TX02-EC      Magnetic tape controller and a DX20 channel for TU72 series tapes.  
TX02-ED      *PREREQUISITE:* RH20

**TU72 SERIES**  
**Add-On Magnetic Tape Drive**

TU72-EC      9-track add-on magnetic tape drive 125 inches per second, 1600/6250 bits per inch.  
TU72-ED      *PREREQUISITE:* TX02-E

**TU72 SERIES**  
**Switch Options**

*(See pages 78 through 82 for configurations.)*

TX03-EC      Two channel switch options and a DX20 channel which includes a BC10Z-25 cable.  
TX03-ED      *PREREQUISITE:* TX02-E; TOPS-10, Release 7.01

TX03-FB      Two channel switches for (2) TX02s which include 4 BC10Y-25 cables.  
*PREREQUISITE:* (2) TX02-Es; TOPS-10, Release 7.01

TX05-EC Two control unit tape switch options and a TX02 which include a BC10X-25, two  
TX05-ED BC10W-25, and two BC10Y-25 cables.  
*PREREQUISITE:* TX02-E; TOPS-10, Release 7.01

TX05-FB Two control unit tape switch options which include a BC10X-25, and two  
BC10W-25 cables.  
*PREREQUISITE:* (2) TX02-Es; TOPS-10, Release 7.01

## LINE PRINTERS

LP100-DA 300 lines per minute, LP05 line printer with 64-character **EDP** drum, 132 columns and  
LP100-DB LP100 controller.

LP100-DC 300 lines per minute, LP05 line printer with 64-character **Scientific** drum, 132 columns  
LP100-DD and LP100 controller.

LP100-EA 240 lines per minute, LP05 line printer with 96-character **EDP** drum, 132 columns and  
LP100-EB LP100 controller.

LP100-EC 240 lines per minute, LP05 line printer with 96-character **Scientific** drum, 132 columns  
LP100-ED and LP100 controller.

LP100-FA 900 lines per minute, LP14 line printer with 64-character **EDP** drum, 132 columns with  
LP100-FB long line interface, and LP100 controller.

LP100-FC 900 lines per minute, LP14 line printer with 64-character **Scientific** drum, 132 columns  
LP100-FD with long line interface, and LP100 controller.

LP100-HA 660 lines per minute, LP14 line printer with 96-character **EDP** drum, 132 columns with  
LP100-HB long line interface, and LP100 controller.

LP100-HC 660 lines per minute, LP14 line printer with 96-character **Scientific** drum, 132 columns  
LP100-HD with long line interface, and LP100 controller.

## CHARABAND LINE PRINTERS

LP100-BA LP07 **Charaband** line printer with LP100 controller, 900/1200 lines per minute.  
LP100-BB Specify one or more charabands listed below.

LP07-YA Charaband containing two sets of **EDP** 64-character fonts.  
*PREREQUISITE:* LP100-B

LP07-YB Charaband containing two sets of **EDP** 96-character fonts.  
*PREREQUISITE:* LP100-B

LP07-YC Standard Charaband containing one set of **EDP** 64-character fonts and one set of **EDP**  
96-character fonts.  
*PREREQUISITE:* LP100-B

LP07-YD Charaband one set of 64-character **EDP** fonts and one set of **Kata Kana** 49-character  
fonts.  
*PREREQUISITE:* LP100-B

LP07-YF Charaband containing one set of **OCR-A** 64-character fonts and one set of **OCR-A** 96-  
character fonts.  
*PREREQUISITE:* LP100-B

LP07-YH Charaband containing two sets of **Scientific** 96-character fonts.  
*PREREQUISITE:* LP100-B

LP07-YJ Charaband containing one set of **EDP** 96-character fonts and one set of **Scientific** 96-  
character fonts.  
*PREREQUISITE:* LP100-B

- LP07-YK Charaband containing two sets of **Swedish/Finnish EDP** 96-character fonts.  
*PREREQUISITE:* LP100-B
- LP07-YL Charaband containing one set of **British EDP** 96-character fonts and one set of **British EDP** 64-character fonts.  
*PREREQUISITE:* LP100-B
- LP07-YM Charaband containing two sets of **Open Gothic EDP** 64-character fonts (IBM 1401).  
*PREREQUISITE:* LP100-B

## CARD EQUIPMENT

- CR10-FA 300 cards per minute table reader and controller.  
*CR10-FB PREREQUISITE:* BA10 (Only available for add-ons to existing BA10s or when reconditioned BA10s are available from Advanced Systems Manufacturing.)
- CR10-HA 1200 cards per minute console reader and controller.  
*CR10-HB PREREQUISITE:* BA10 (Only available for add-ons to existing BA10s or when reconditioned BA10s are available from Advanced Systems Manufacturing.)

## PAPER TAPE

- PC10-CL 300 characters per second paper tape reader/50 characters per second punch including a cabinet, power supplies, and a PC04 high-speed PTR/PTP.  
*PC10-CM PREREQUISITE:* DIA (Digital Analyzer & Monitoring Device), which is included on the KL10-D.

## DN20 FRONT END COMMUNICATIONS

### Universal Front Ends

*(See page 15 for configurations.)*

The DN20 is a universal data communications front end used on DECsystem-10. It requires the addition of DN20-xx and DN21-xx options for synchronous operations and/or DN25-xx for asynchronous operations.

The DN20 universal data communications front ends operate with TOPS-10 Networks, DECnet-10 or IBM 2780/3780 communications software. The TOPS-10 Networks software is included with the TOPS-10 operating system. DECnet-10 and IBM communications software are both optional and must be purchased separately. Refer to TOPS-10, DECnet-10 and DECsystem-10 2780/3780 E/T SPDs for software descriptions.

DN20 universal data communications front ends also support the addition of a DN200 remote job entry station for which software is included in the TOPS-10 operating system (see DN200 configurator).

Up to three DN20 front ends can be configured per CPU (see DN20 configurator). IBM front ends, TOPS-10 Network and DECnet-10 front ends can be configured in any mix, except that IBM front ends must be used on CPU 0 of a SMP system. TOPS-10 Network software and DECnet-10 software can co-reside in one physical subsystem; however, IBM communications software requires a separate front end subsystem.

The DN20-based communications front ends do not include single-device cables to asynchronous terminals or modems. Cables must be ordered separately. (See cable information in Additional Equipment and Information Section.)

- DN20-CC Data Communications Universal Front End with 32K words of core memory which requires the addition of DN20-xx, DN21-xx, or DN25-xx options for synchronous and asynchronous operations.  
*DN20-CD*

## DN20 FRONT END COMMUNICATIONS

### Synchronous Line Interfaces

- DN20-BA Low speed synchronous line controller, including one low speed line interface (KMC11/DUP11) expandable to 4 lines with the addition of the DN20-BB.  
*PREREQUISITE:* DN20-C

- DN20-DA  
DN20-DB Synchronous expansion drawer, including one low speed line interface (KMC11/ DUP11) expandable to 4 lines with the addition of the DN20-BB.  
*PREREQUISITE:* DN20-BA
- DN20-BB Low speed synchronous line interface (DUP11) for speeds between 2.4Kb and 19.2Kb baud (RS-232-C modem interface).  
*PREREQUISITE:* DN20-BA or DN20-DA
- DN21-DA  
DN21-DB Synchronous expansion drawer, including one high speed line interface (DMC11-AR/FA) expandable to 4 lines with the addition of the DN21-BA.  
*PREREQUISITE:* DN20-C
- DN21-BA High speed synchronous line interface (DMC11-AR/FA) for speeds between 19.2Kb and 56.0Kb baud.  
*PREREQUISITE:* DN21-D

## **DN20 FRONT END COMMUNICATIONS**

### **Asynchronous Line Interfaces**

- DN25-EC  
DN25-ED Asynchronous expansion cabinet and first drawer including one 8-line multiplexer.  
*PREREQUISITE:* DN20-C
- DN25-DA  
DN25-DB Asynchronous expansion drawer including one 8-line multiplexer (expandable to 16 lines with the addition of a DN25-BA).  
*PREREQUISITE:* DN25-E
- DN25-AA 8-line asynchronous line multiplexer and controller (expandable to 16 lines with the addition of a DN25-BA).  
*PREREQUISITE:* DN25-AB, DN200
- DN25-AB 8-line asynchronous multiplexer with distribution panel (expandable to 16 lines with the addition of a DN25-BA).  
*PREREQUISITE:* DN25-A/D/E
- DN25-BA 8-line asynchronous expansion multiplexer.  
*PREREQUISITE:* DN25-A/D/E

## **DN200 REMOTE STATION**

*(See page 17 for configurations.)*

- DN200-AA  
DN200-AB Remote Station including only the Kernal hardware and console terminal which requires the addition of add-on options for operations.  
*PREREQUISITE:* DN87 or DN20

## **DN200 OPTIONS (See DN25-Ax/Bx for DN200 Asynchronous Line interfaces.)**

- DNSXX-AA Synchronous line unit (DMC11-AR/DA) for speeds between 2.4Kb and 19.2Kb baud (RS-232-C interface with cable).  
*PREREQUISITE:* DN200-A
- DNSXX-AB Synchronous line unit (DMC11-AR/FA) for speeds between 19.2Kb and 56.0Kb baud.  
*PREREQUISITE:* DN200-A
- DNLXX-BA  
DNLXX-BB 300 lines per minute, LP05 line printer with 64-character **EDP** drum, 132 columns.  
*PREREQUISITE:* DN200-A
- DNLXX-CA  
DNLXX-CB 230 lines per minute, LP05 line printer with 96-character **EDP** drum, 132 columns.  
*PREREQUISITE:* DN200-A
- DNCXX-AA  
DNCXX-AB 300 cards per minute card reader.  
*PREREQUISITE:* DN200-A

## **CPU PACKAGE UPGRADES TO THE DECsystem 1090**

- 1090-VC      Upgrade for the KA10 or KI10 to KL10-D. This upgrade package includes the KL10-D  
1090-VD      Central Processor (includes one RH20 controller), RP06-B Disk Pack Drive, an LA120  
console terminal, Software License and Sources<sup>2</sup> for TOPS-10 and the Initial Support  
Package. There is an allowance for the KA and KI processor trade-ins (see the Large  
Computer Group Price List).  
*PREREQUISITE: KA10/KI10*
- KL10-PM      Upgrade for the KL10-A CPU to the KL10-B CPU. This upgrade adds backplane wiring for  
KL10-PG<sup>1</sup>      up to 8 MASSBUS controllers and the wiring for up to 3 DTE Communication Interfaces.  
Channels or controllers are not included.
- KL10-PV<sup>1</sup>      Upgrade for the KL10-B CPU to the KL10-D CPU. This will upgrade the KL10-B CPU to the  
latest design. Channels or controllers are not included.

<sup>1</sup>Does not include software.

<sup>2</sup>Does not include Front-End Sources.

## **DUAL KI10 UPGRADE**

- 1077-UA      TOPS-10 DPE (dual processor extension) Version 7.01 software and KI10 processor up-  
grade kit for existing KI10 processor site.

**On Dual KI10 configurations, all I/O equipment is connected to the Policy CPU. Bus switches can be used to redefine the Policy CPU if reconfiguration is required.**

Refer to TOPS-10 DPE SPD (SPD 7.9) for software description.

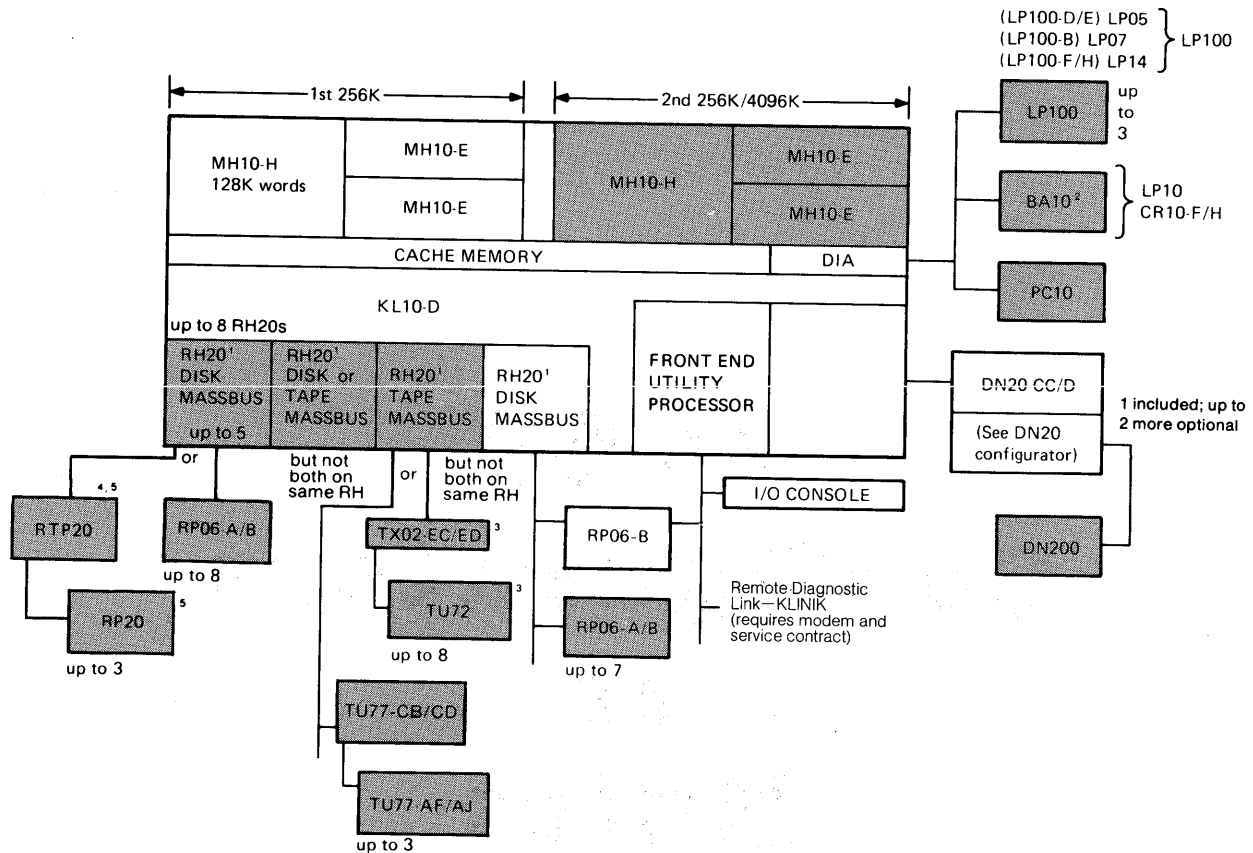
**1090**  
**Configurators**  
**&**  
**Rules**

## DECsystem-1090-P CORE CONFIGURATOR

**Basic System includes:**  
 CPU and Cache Memory  
 256K Words Core Memory  
 One MASSBUS Controller for Disks

RP06 Disk pack Drive  
 16 Asynchronous Lines  
 LA120 Console Terminal

A minimum system must include the basic system package plus a tape subsystem, and a line printer.



**BASIC SYSTEM:** SHADED AREA OPTIONAL

<sup>1</sup>The system will accommodate up to eight RH20 MASSBUS channels of which:

- One must be used for disk to support the dual ported RP06-B system disk that connects to the front end utility processor.
- One must be used for tape to support the minimum system requirements of at least one 9-track tape drive to a system.
- The remaining six RH20 MASSBUS channels may be used for either disk or tape.

<sup>2</sup>The BA10 devices are not sold on the DECsystem-1090 but may be attached from the KA or KI CPU upgrades.

<sup>3</sup>See pages 78 through 82 for additional TX02, TX03, TX05, and TU72 configuration information.

<sup>4</sup>RH20 is included with RTP20 option (otherwise it is purchased separately).

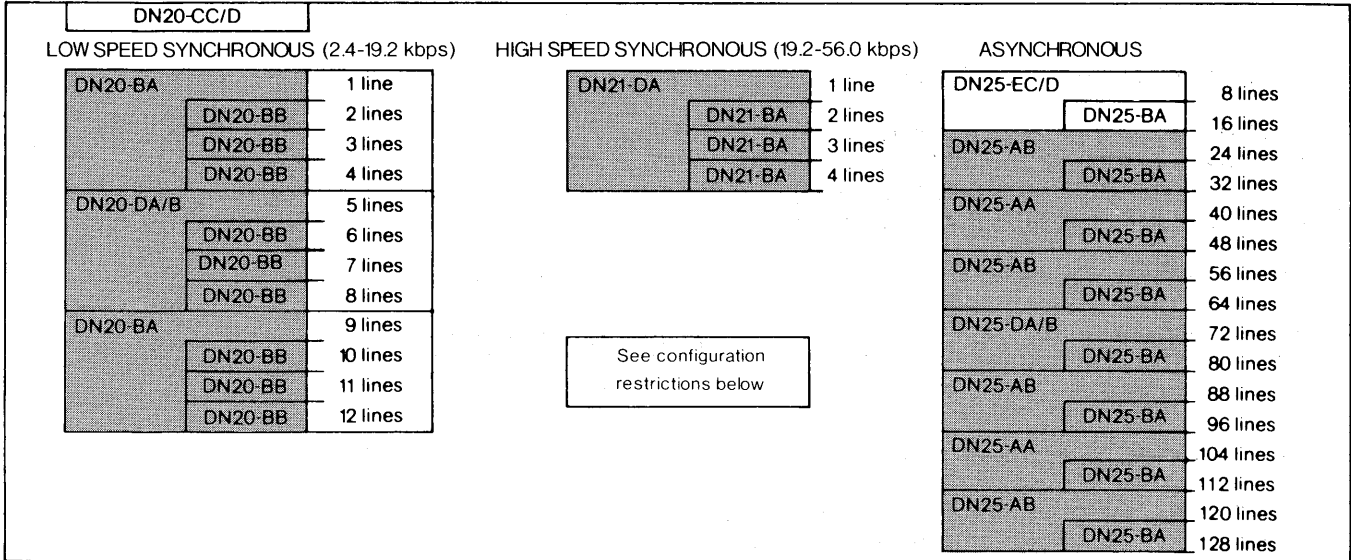
<sup>5</sup>See pages 73 through 76 for RP20 configuration information.

# DN20 UNIVERSAL COMMUNICATIONS FRONT END CONFIGURATOR

(TOPS-10 Networks, DECnet-10, or IBM Communications)

Up to three DN20 front ends can be configured per CPU. The following configuration rules apply to **EACH** DN20 Front End.

## TOPS-10 NETWORKS AND DECNET-10 COMMUNICATIONS



**BASIC SYSTEM:** SHADED AREA OPTIONAL

TOPS-10 network software is included with the Basic System Package. DECnet-10 (QH682) is optional software. Consult the relevant SPD for a software description. You may combine (co-reside) TOPS-10 Networks and DECnet-10 in the same DN20 front end if you wish.

### Configuration Rules

- The combined number of synchronous lines configured is dependent on the number of asynchronous lines configured.

The general rules for configuring synchronous and asynchronous lines on a DN20 are:

Number of Synchronous Lines (High & Low Speed Combined)	Maximum Number of Asynchronous Lines
0	128
4	64
8	32
12	0

- The number of high speed synchronous lines configured is dependent on the number of low speed synchronous lines configured.

The general rule for configuring high speed and low speed synchronous lines on a DN20 takes aggregate line speed into account and whether or not asynchronous lines are configured. Aggregate line speed is the sum of the individual line speeds.

**No Asynchronous Lines**

$$\frac{\text{Aggregate Speed of DN20-Bs}}{38\text{Kb}} + \frac{\text{Aggregate Speed of DN21s}}{75\text{Kb}} \leq 1.2$$

Examples of supported configurations:

- 12 DN20s at 2.4 Kbps, no DN21s
- 4 DN21s at 19.2 Kbps, no DN20s
- 1 DN21 at 56.0 Kbps, 1 DN20 at 9.6 Kbps
- 6 DN20s at 2.4 Kbps, 2 DN21s at 19.2 Kbps

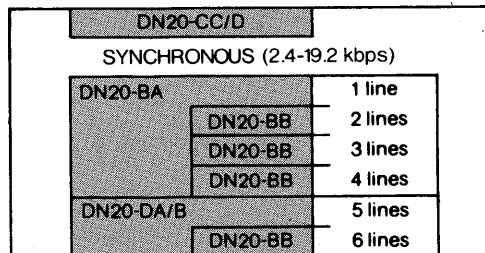
**With Asynchronous Lines**

$$\frac{\text{Aggregate Speed of DN20-Bs}}{19.2\text{Kb}} + \frac{\text{Aggregate Speed of DN21s}}{55\text{Kb}} \leq 1.2$$

Examples of supported configurations:

- 2 DN20s at 9.6 Kbps, no DN21s, 64 Asynch
- 3 DN21s at 19.2 Kbps, no DN20s, 64 Asynch
- 2 DN20s at 2.4 Kbps, 1 DN21 at 56 Kbps, 64 Asynch

**IBM COMMUNICATIONS**



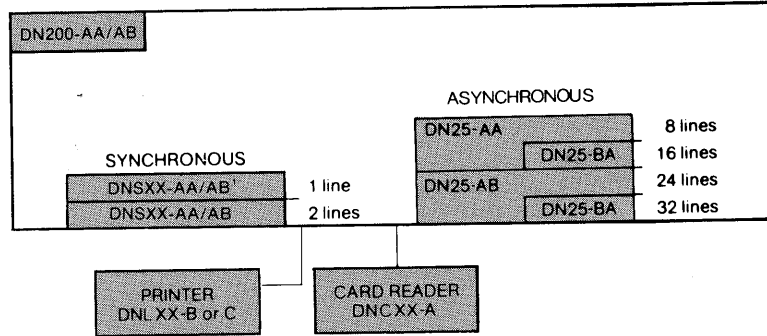
**BASIC SYSTEM:** SHADED AREA OPTIONAL

TOPS-10 Networks and DECnet-10 cannot co-reside with DECsystem-10 2780/3780 E/T (IBM communications) in the same DN20.

DECsystem-10 2780/3780 E/T (QH603) must be purchased separately.

A maximum of six bisynchronous lines (DN20-Bx) are supported per DN20.

## DN200 CONFIGURATOR



**BASIC SYSTEM:** SHADED AREA OPTIONAL

Software for the DN200 is included in the Basic System Package.

The first DNSXX-AA/AB is used for connecting to the system. A DN20-BA, BB, or DA or DN21-BA, BB, or DA is required in the DN20 Front End.

### Configuration Rules

DN200s are to be treated as DN20 low speed lines when configuring DN21 high speed synchronous lines and/or DN25 asynchronous lines in the DN20 Front End. The maximum configuration would be 36 DN200s. (Three DN20 Front Ends  $\times$  12 low speed lines per Front End.)

Connection of synchronous interfaces such as the DN20 to the DN200 without modems requires the use of a synchronous modem eliminator (a null modem with clock). DIGITAL does not sell such a device, but one can be obtained from several communications vendors or their representatives. A synchronous modem eliminator, or two modems, must be provided by the customer before any installation can occur.

# **DECsystem-1091 System & Options**

## 1091 BASIC SYSTEM PACKAGE

- KL10-E Central Processor with Cache Memory
- MCA20 Cache Memory
- 2 - RH20 (for disk and tapes)
- 256K words MF20 MOS Memory
- One RP06-B Disk
- LA120 Console Terminal
- 16 Asynchronous Lines (Console Front End)
- Initial Support Package
- TOPS-10 Operating System (with TOPS-10 License)
- TOPS-10 Sources (Front End (RSX-20F) Sources are not included)

## INITIAL SUPPORT PACKAGE

- Ten training credits
- Hardware installation with 90-day warranty
- Software installation with 90-day warranty
- One set of Software Notebooks and 90 day Update service
- Five sets of manuals (for the Operating System)

**A minimum system must include, in addition to the basic system package, a magnetic tape subsystem with a 1600 bit per inch, 9-track tape transport and a line printer.**

## BASIC SYSTEM PACKAGES

1091-SC      Basic System Package with Initial Support Package.  
1091-SD

## LICENSE ONLY PACKAGES *(Purchases of License Only Packages require a prerequisite of at least one fully supported Basic System Package.)*

1091L-SC      License Only Package  
1091L-SD      *PREREQUISITE:* 1091 Basic System Package

## MOS MEMORY

MF20-LA      256K word MOS memory with space for 2 MF20-Es, first backplane.  
MF20-LB

MF20-LC      256K word MOS memory with space for two MF20-Es, second backplane.  
MF20-LD

MF20-LM      256K word External MOS memory with space for 2 MF20-Es, first external backplane.  
MF20-LN      *PREREQUISITE:* TOPS-10, Release 7.01

MF20-LK      256K word External MOS memory with space for 2 MF20-Es, second external backplane.  
MF20-LL      *PREREQUISITE:* TOPS-10, Release 7.01

MF20-E      256K word expansion memory.  
*PREREQUISITE:* MF20-L

## 1091L LICENSE ONLY PACKAGE

- KL10-E Central Processor with Cache Memory
- MCA20 Cache Memory
- 2 - RH20 (for disk and tapes)
- 256K words MF20 MOS Memory
- One RP06-B Disk
- LA120 Console Terminal
- 16 Asynchronous Lines (Console Front End)
- Hardware installation with 90-day warranty
- TOPS-10 Operating System License

**A minimum system must include in addition to the license only package, a magnetic tape subsystem with a 1600 bit per inch 9-track tape transport and a line printer.**

## MF20 MEMORY CONFIGURATOR

(Number of units of each memory type required for memory size)

Memory Size (words)	MF20-LA(LB)*	MF20-LC(LD)	MF20-LM(LN)	MF20-LK(LL)	MF20-E
256K*	1				
512K	1				1
768K	1				2
1024K	1	1			2
1280K	1	1			3
1536K	1	1			4
1792K	1	1	1		4
2048K	1	1	1		5
2304K	1	1	1		6
2560K	1	1	1	1	6
2816K	1	1	1	1	7
3072K	1	1	1	1	8

\*Memory included in the system package is shown here for upgrades only.

## DISK & TAPE CONTROLLER

RH20 MASSBUS controller for disks and tapes.

## ADD-ON DISK PACK DRIVES

RP06-AA Single access 176.0 megabyte word add-on disk pack drive which includes one RP06-P disk pack.  
 RP06-AB  
 PREREQUISITE: RH20

RP06-BA Dual access 176.0 megabyte word add-on disk pack drive which includes one RP06-P disk pack.  
 RP06-BB  
 PREREQUISITE: RH20

RP06-C RP06 dual access kit.  
 PREREQUISITE: RP06-A

## RP20 SERIES

### Master Disk Subsystem

RTP20-EA 967MB Fixed media disk master subsystem. Includes an RH20 and RP20 software.  
 RTP20-EB

## RP20 SERIES

### Add-On Disk Units

RP20-AC 967MB Fixed media add-on disk unit TOPS-10 format.  
 RP20-AD PREREQUISITE: RTP20

## **RP20 SERIES**

### **Options**

- RTP20-EC      Dual channel option for RTP20 master subsystem.  
RTP20-ED      *PREREQUISITE:* RTP20-EA/EB,FH/FJ
- RP20-CA      Dual port option for master subsystem.  
*PREREQUISITE:* RTP20
- RP20-CB      Dual port option for add-on disk unit.  
*PREREQUISITE:* RP20-A

### **NOTE RP20 CABLES**

All cables necessary to configure are supplied and are 20 feet long. Other lengths are available at additional charge. Consult the RTP20 Disk System Options Bulletin - Order No. ED 19725 26.

## **TU77 SERIES**

### **Magnetic Tape Subsystem**

- TU77-CB      Magnetic tape subsystem including a controller and one 9-track master tape drive 125  
TU77-CD      inches per second, 800/1600 bits per inch (expandable to a maximum of 4 tape drives  
per controller with the addition of the TU77-AF(AJ) add-on tape drive).  
*PREREQUISITE:* RH20

## **TU77 SERIES**

### **Add-On Magnetic Tape Drive**

- TU77-AF      9-track add-on magnetic tape drive 125 inches per second, 800/1600 bits per inch.  
TU77-AJ      *PREREQUISITE:* TU77-CB(CD)

## **TU72 SERIES**

### **Magnetic Tape Controller**

- TX02-EH      Magnetic tape controller and a DX20 channel for TU72 series tapes.  
TX02-EJ      *PREREQUISITE:* RH20

## **TU72 SERIES**

### **Add-On Magnetic Tape Drive**

- TU72-EC      9-track add-on magnetic tape drive 125 inches per seconds, 1600/6250 bits per inch.  
TU72-ED      *PREREQUISITE:* TX02-E

## **TU72 SERIES**

### **Switch Options**

*(See pages 77 through 81 for configurations.)*

- TX03-EH      Two channel switch options and a DX20 channel which includes a BC10Z-25 cable.  
TX03-EJ      *PREREQUISITE:* TX02-E; TOPS-10, Release 7.01
- TX03-FB      Two channel switches for (2) TX02s which include 4 BC10Y-25 cables.  
*PREREQUISITE:* (2) TX02-Es; TOPS-10, Release 7.01

- TX05-EC  
TX05-ED Two channel unit tape switch options and a TX02 which includes a BC10X-25, BC10W-25, and two BC10Y-25 cables.  
*PREREQUISITE:* TX02-E; TOPS-10, Release 7.01
- TX05-FB Two control unit tape switch options which include a BC10X-25, and two BC10W-25 cables.  
*PREREQUISITE:* (2) TX02-Es; TOPS-10, Release 7.01

## LINE PRINTERS

- LP20-AA  
LP20-AB 300 lines per minute, LP05 line printer with 64-character **EDP** drum, 132 columns, LP20 controller and cable kit.
- LP20-AC  
LP20-AD 300 lines per minute, LP05 line printer with 64-character **Scientific** drum, 132 columns, LP20 controller and cable kit.
- LP20-BA  
LP20-BB 240 lines per minute, LP05 line printer with 96-character **EDP** drum, 132 columns, LP20 controller and cable kit.
- LP20-BC  
LP20-BD 240 lines per minute, LP05 line printer with 96-character **Scientific** drum, 132 columns, LP20 controller and cable kit.
- LP20-CA  
LP20-CB 900 lines per minute, LP14 line printer with 64-character **EDP** drum, 132 columns, LP20 controller and cable kit.
- LP20-CC  
LP20-CD 900 lines per minute, LP14 line printer with 64-character **Scientific** drum, 132 columns, LP20 controller and cable kit.
- LP20-DA  
LP20-DB 660 lines per minute, LP14 line printer with 96-character **EDP** drum, 132 columns, LP20 controller and cable kit.
- LP20-DC  
LP20-DD 660 lines per minute, LP14 line printer with 96-character **Scientific** drum, 132 columns, LP20 controller and cable kit.

## CHARABAND LINE PRINTERS

- LP200-BA  
LP200-BB LP07 **Charaband** line printer with LP20 controller and cable kit, 900/1200 lines per minute. Specify one or more charabands listed below.
- LP07-YA Charaband containing two sets of **EDP** 64-character fonts.  
*PREREQUISITE:* LP200-B
- LP07-YB Charaband containing two sets of **EDP** 96-character fonts.  
*PREREQUISITE:* LP200-B
- LP07-YC Standard Charaband containing one set of **EDP** 64-character fonts and one set of **EDP** 96-character fonts.  
*PREREQUISITE:* LP200-B
- LP07-YD Charaband containing one set of 64-character **EDP** fonts and one set of **Kata Kana** 49-character fonts.  
*PREREQUISITE:* LP200-B
- LP07-YF Charaband containing one set of **OCR-A** 64-character fonts and one set of **OCR-A** 96-character fonts.  
*PREREQUISITE:* LP200-B
- LP07-YH Charaband containing two sets of **Scientific** 96-character fonts.  
*PREREQUISITE:* LP200-B

- LP07-YJ Charaband containing one set of **EDP** 96-character fonts and one set of **Scientific** 96-character fonts.  
*PREREQUISITE:* LP200-B
- LP07-YK Charaband containing one set of **Swedish/Finnish EDP** 96-character fonts.  
*PREREQUISITE:* LP200-B
- LP07-YL Charaband containing one set of **British EDP** 96-character fonts and one set of **British EDP** 64-character fonts.  
*PREREQUISITE:* LP200-B
- LP07-YM Charaband containing two sets of **Open Gothic EDP** 64-character fonts (IBM 1401).  
*PREREQUISITE:* LP200-B

#### **CARD EQUIPMENT**

- CD20-AA 300 cards per minute table reader and controller.  
*CD20-AB*
- CD20-CA 1200 cards per minute console reader and controller.  
*CD20-CB*

#### **PAPER TAPE**

- PC20-BL 300 characters per second paper tape reader/50 characters per second punch including a cabinet, power supplies, and a PC04 high-speed PTR/PTP.  
*PC20-BM*  
*PREREQUISITE:* DIB20

#### **I/O BUS INTERFACE**

- DIB20 I/O Bus Interface.

#### **FRONT END COMMUNICATIONS** **Asynchronous Line Interfaces**

*(Cables are not included with the DC20 interfaces)*

- DC20-AA Basic 8-line asynchronous interface (DH11-AD) expandable to 16 lines with the addition of the DC20-DA.
- DC20-DA 8-line asynchronous expansion interface (a maximum of one DC20-DA per DC20-AAs).  
*PREREQUISITE:* DC20-AA
- DC20-CD Distribution cabinet (required for configuration between 32 and 128 lines).  
*PREREQUISITE:* DC20
- DC20-EA Communications expansion cabinet for over 32 lines which includes one DC20-AA (can accommodate up to three additional DC20-AAs).  
*DC20-EB*  
*PREREQUISITE:* DC20-CD

#### **DN20 FRONT END COMMUNICATIONS** **Universal Front Ends**

*(See page 29 for configurations.)*

The DN20 is a universal data communications front end used on DECsystem-10. It requires the addition of DN20-xx and DN21-xx options for synchronous operations and/or DN25-xx for asynchronous operations.

The DN20 universal data communications front ends operate with TOPS-10 Networks, DECnet-10 or IBM 2780/3780 communications software. The TOPS-10 Networks software is included with the TOPS-10 operating system. DECnet-10 and IBM communications software are both optional and must be purchased separately. Refer to TOPS-10, DECnet-10 and DECsystem-10 2780/3780 E/T SPDs for software descriptions.

DN20 universal data communications front ends also support the addition of a DN200 remote job entry station for which software is included in the TOPS-10 operating system.

Up to three DN20 front ends can be configured per CPU (see DN20 configurator). IBM front ends, TOPS-10 Network and DECnet-10 front ends can be configured in any mix. TOPS-10 Network software and DECnet-10 software can co-reside in one physical subsystem, however, IBM communication software requires a separate front end subsystem.

The DN20-based communications front ends do not include single-device cables to asynchronous terminals or modems. Cables must be ordered separately. (See cable information in the Additional Equipment and Information Section.)

**DN20-CC**      Data Communications Universal Front End with 32K words of core memory which requires  
*DN20-CD*      the addition of the DN20-xx, DN21-xx, or DN25-xx options for synchronous and asynchro-  
                  nous operations).

## **DN20 FRONT END COMMUNICATIONS**

### **Synchronous Line Interfaces**

**DN20-BA**      Low speed synchronous line controller including one low speed line interface  
                  (KMC11/DUP11) expandable to 4 lines with the addition of the DN20-BB.  
*PREREQUISITE: DN20-C*

**DN20-DA**      Synchronous expansion drawer including one low speed line interface (KMC11/DUP11)  
*DN20-DB*      expandable to 4 lines with the addition of the DN20-BA.  
*PREREQUISITE: DN20-BA*

**DN20-BB**      Low speed synchronous line interface (DUP11) for speeds between 2.4Kb and 19.2Kb  
                  baud (RS-232-C modem interface).  
*PREREQUISITE: DN20-BA or DN20-DA*

**DN21-DA**      Synchronous expansion drawer including one high speed line interface (DMC11-AR/FA)  
*DN21-DB*      expandable to 4 lines with the addition of the DN21-BA.  
*PREREQUISITE: DN20-C*

**DN21-BA**      High speed synchronous line interface (DMC11-AR/FA) for speeds between 19.2Kb and  
                  56.0Kb baud.  
*PREREQUISITE: DN21-D*

## **DN20 FRONT END COMMUNICATIONS**

### **Asynchronous Line Interfaces**

**DN25-EC**      Asynchronous expansion cabinet and first drawer including one 8-line multiplexer.  
*DN25-ED*      *PREREQUISITE: DN20-C*

**DN25-DA**      Asynchronous expansion drawer including one 8-line multiplexer (expandable to 16 lines  
*DN25-DB*      with the addition of a DN25-BA).  
*PREREQUISITE: DN25-E*

**DN25-AA**      8-line asynchronous line multiplexer and controller (expandable to 16 lines with the addi-  
                  tion of a DN25-BA).  
*PREREQUISITE: DN25-AB, DN200*

**DN25-AB**      8-line asynchronous multiplexer with distribution panel (expandable to 16 with addition of  
                  a DN25-BA).  
*PREREQUISITE: DN25-A/D/E*

**DN25-BA**      8-line asynchronous expansion multiplexer.  
*PREREQUISITE: DN25-A/D/E*

## DN200 REMOTE STATION

*(See page 31 for configuration.)*

DN200-AA Remote Station including only the Kernal hardware and console terminal which requires  
DN200-AB the addition of add-on options for operations.  
PREREQUISITE: DN87 or DN20

## DN200 OPTIONS *(See DN25-Ax/Bx for DN200 Asynchronous Line interfaces.)*

DNSXX-AA Synchronous line unit (DMC11-AR/DA) for speeds between 2.4Kb and 19.2 Kb baud  
(RS-232-C interface with cable).  
PREREQUISITE: DN200-A

DNSXX-AB Synchronous line unit (DMC11-AR/FA) for speeds between 19.2Kb and 56.0Kb baud.  
PREREQUISITE: DN200-A

DNLXX-BA 300 lines per minute, LP05 line printer with 64-character **EDP** drum, 132 columns.  
DNLXX-BB PREREQUISITE: DN200-A

DNLXX-CA 230 lines per minute, LP05 line printer with 96-character **EDP** drum, 132 columns.  
DNLXX-CB PREREQUISITE: DN200-A

DNCXX-AA 300 cards per minute card reader.  
DNCXX-AB PREREQUISITE: DN200-A

## UPGRADES

### Upgrades from 1091P (Core System) to 1091S (MOS System)

MB20 core memory in its maximum configuration consists of two memory sections, each with a maximum of 256K words per section of 512KW per system.

When expanding with or upgrading to MOS memory, at least one section of core must be removed. That is, up to 256K words of core may be retained in one section if desired. The MOS memory section (MF20-LA) added can expand up to 756K words. Expansion beyond 1M word (756KW MOS + 256KW core) will require replacement of the remaining core section by a second MOS section.

**1091**  
**Configurators**  
**&**  
**Rules**

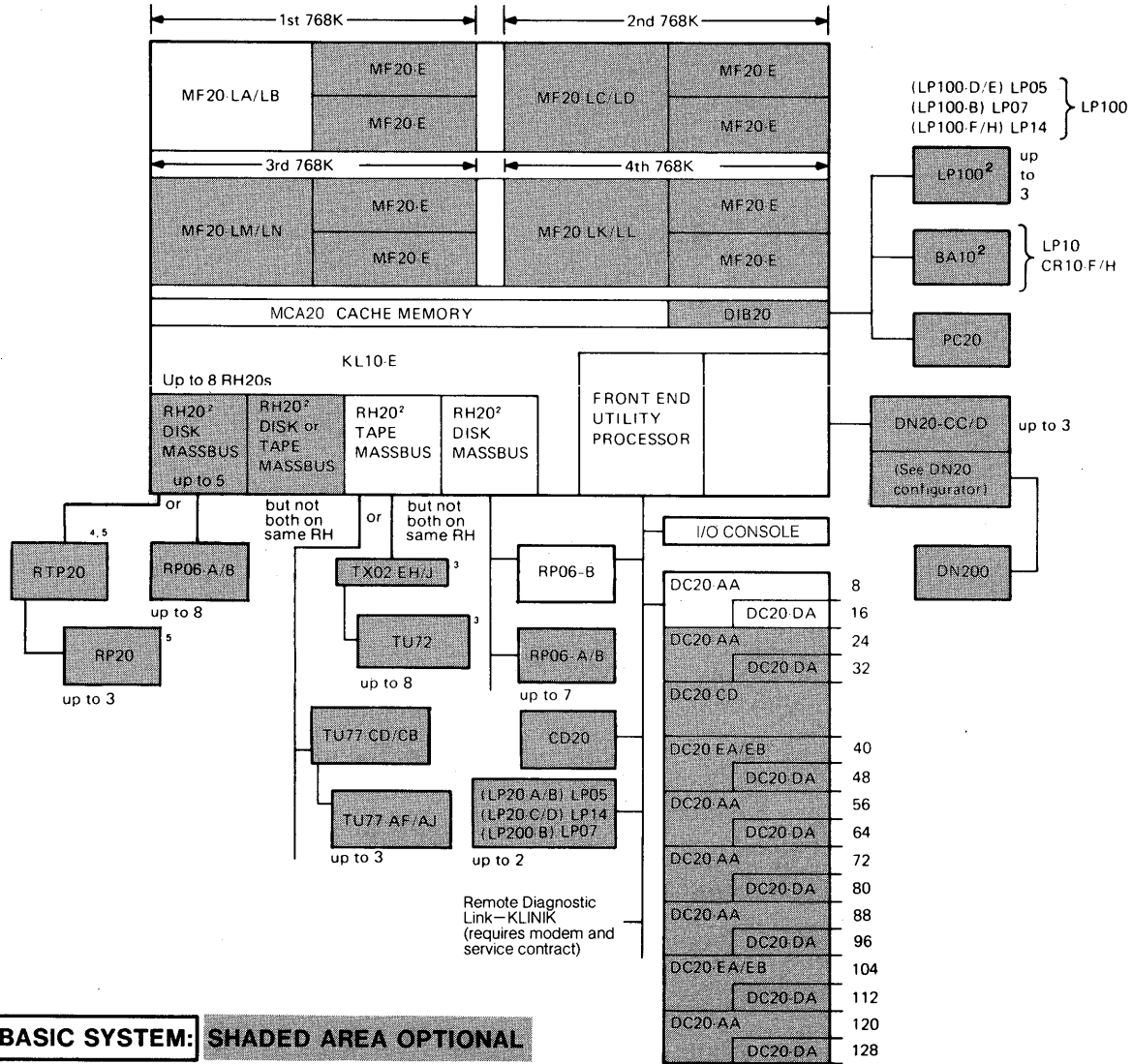
## DECsystem-1091-S MOS CONFIGURATOR

**Basic System includes:**

CPU and Cache Memory  
 256K Words MOS Memory  
 Two MASSBUS Controllers  
 for Disk and Tapes

RP06 Disk Pack Drive  
 16 Asynchronous Lines  
 LA120 Console Terminal

A minimum system must include the basic system package plus a tape subsystem, and a line printer.



<sup>1</sup>The system will accommodate up to eight RH20 MASSBUS channels of which:

- One must be used for the disk to support the dual ported RP06-B system disk that connects to the front end utility processor.
- One must be used for the tape to support the minimum system requirements of at least one 9-track tape drive to a system.
- The remaining six RH20 MASSBUS channels may be used for either disk or tape.

<sup>2</sup>The BA10 devices and the LP100 line printer are not sold on the DECsystem-1091. They may be attached from the KA or KI CPU upgrades but require the addition of a DIB20.

<sup>3</sup>See pages 77 through 81 for additional TX02, TX03, TX05, and TU72 configuration information.

<sup>4</sup>RH20 is included with the RTP20 option (otherwise it is purchased separately).

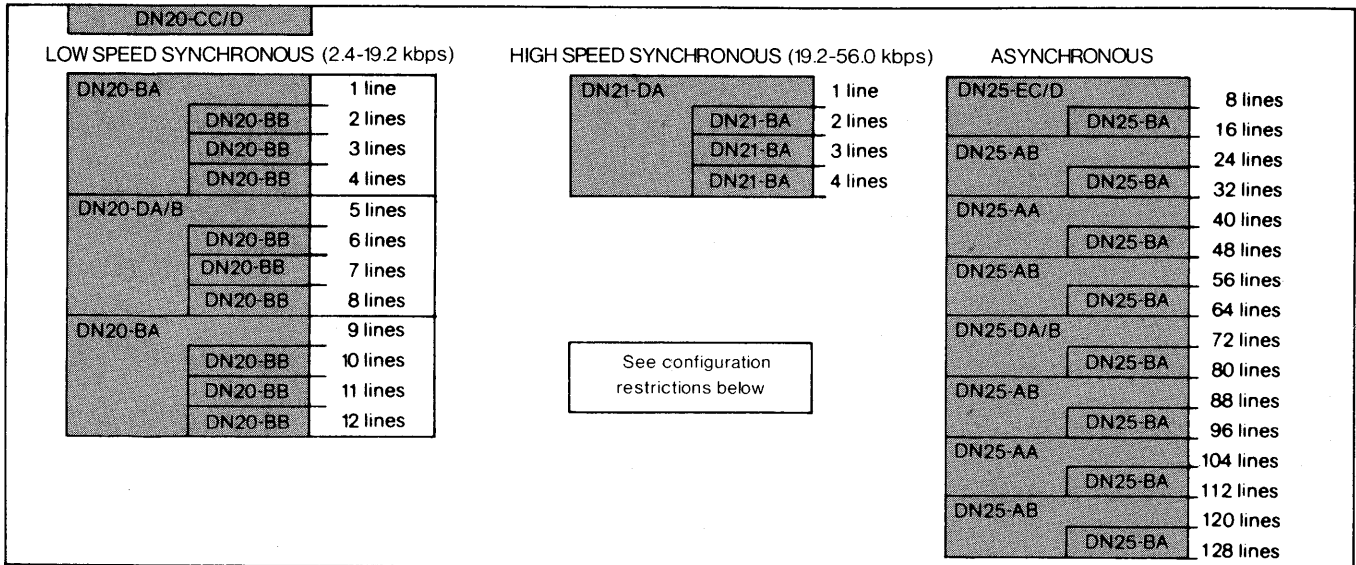
<sup>5</sup>See pages 73 through 76 for RP20 configuration information.

# DN20 UNIVERSAL COMMUNICATIONS FRONT END CONFIGURATOR

(TOPS-10 Networks, DECnet-10, or IBM Communications)

Up to three DN20 front ends can be configured per CPU. The following configuration rules apply to **EACH** DN20 Front End.

## TOPS-10 NETWORKS AND DECNET-10 COMMUNICATIONS



### BASIC SYSTEM: SHADED AREA OPTIONAL

TOPS-10 Networks software is included with the Basic System Package. DECnet-10 (QH682) is optional software. Consult the relevant SPD for a software description. You may combine (co-reside) TOPS-10 Networks and DECnet-10 in the same DN20 front end if you wish.

### Configuration Rules

- The combined number of synchronous lines configured is dependent upon the number of asynchronous lines configured.

The general rules for configuring synchronous and asynchronous lines on a DN20 are:

<u>Number of Synchronous Lines (High &amp; Low Speed Combined)</u>	<u>Maximum Number of Asynchronous Lines</u>
0	128
4	64
8	32
12	0

- The number of high speed synchronous lines configured is dependent upon the number of low speed lines configured.

The general rule for configuring high speed and low speed synchronous lines on a DN20 takes aggregate line speed into account and whether or not asynchronous lines are configured. Aggregate line speed is the sum of the individual line speeds.

**No Asynchronous Lines**

$$\frac{\text{Aggregate Speed of DN20-Bs}}{38\text{Kb}} + \frac{\text{Aggregate Speed of DN21s}}{75\text{Kb}} \leq 1.2$$

Examples of supported configurations:

- 12 DN20s at 2.4 Kbps, no DN21s
- 4 DN21s at 19.2 Kbps, no DN20s
- 1 DN21 at 56.0 Kbps, 1 DN20 at 9.6 Kbps
- 6 DN20s at 2.4 Kbps, 2 DN21s at 19.2 Kbps

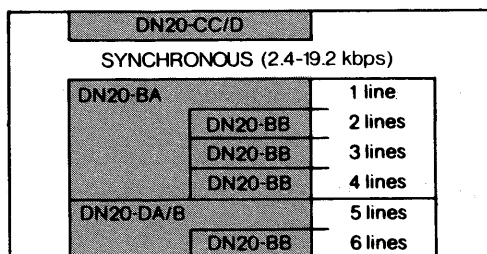
**With Asynchronous Lines**

$$\frac{\text{Aggregate Speed of DN20-Bs}}{19.2\text{Kb}} + \frac{\text{Aggregate Speed of DN21s}}{55\text{Kb}} \leq 1.2$$

Examples of supported configurations:

- 2 DN20s at 9.6 Kbps, no DN21s, 64 Asynch
- 3 DN21s at 19.2 Kbps, no DN20s, 64 Asynch
- 2 Dn20s at 2.4 Kbps, 1 DN21 at 56 Kbps, 64 Asynch

**IBM COMMUNICATIONS**



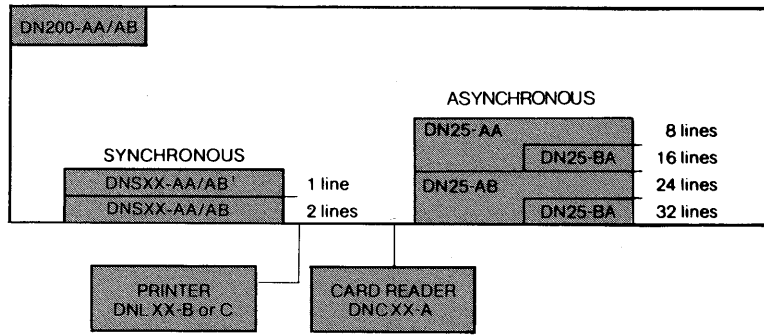
**BASIC SYSTEM:** SHADED AREA OPTIONAL

TOPS-10 Networks and DECnet-10 cannot co-reside with DECsystem-10 2780/3780 E/T (IBM communications) in the same DN20.

DECsystem-10 2780/3780 E/T (QH603) must be purchased separately.

A maximum of six bisynchronous lines (DN20-Bx) are supported per DN20.

## DN200 CONFIGURATOR



**BASIC SYSTEM:** SHADED AREA OPTIONAL

Software for the DN200 is included in the Basic System Package.

<sup>1</sup>The first DNSXX-AA/AB is used for connecting to the system. A DN20-BA, BB, or DA or DH21-BA, BB, or DA is required in the DN20 Front End.

### Configuration Rules

DN200s are to be treated as DN20 low speed lines when configuring DN21 high speed synchronous lines and/or DN25 asynchronous lines in the DN20 Front End. The maximum configuration would be 36 DN200s. (Three DN20 Front Ends × 12 low speed lines per Front End.)

Connection of synchronous interfaces such as the DN20 to the DN200 without modems requires the use of a synchronous modem eliminator (a null modem with clock). DIGITAL does not sell such a device, but one can be obtained from several communications vendors or their representatives. A synchronous modem eliminator, or two modems, must be provided by the customer before any installation can occur.

# **DECSYSTEM-2020**

## **Systems & Options**

## 2020 BASIC SYSTEM PACKAGES

### TOPS-10

- KS10 Central Processor
- 256K words MS10 Memory
- One RM03 or RP06 Disk
- LA120 Console Terminal
- 16 Asynchronous Lines
- TOPS-10 Operating System (with TOPS-10 License)
- TOPS-10 Sources
- Initial Support Package
- 25 day Consulting Services Package

### TOPS-20

- KS10 Central Processor
- 256K words MS10 Memory
- One RM03 or RP06 Disk
- LA120 Console Terminal
- 16 Asynchronous Lines
- TOPS-20 Operating System (with TOPS-20 License)
- Initial Support Package
- 25 day Consulting Services Package

**A minimum system must include in addition to the basic system package, a magnetic tape subsystem with a 1600 bit per inch 9-track tape transport and a line printer.**

### INITIAL SUPPORT PACKAGE

- Ten Training Credits
- Hardware installation with 90-day warranty
- Software installation with 90-day warranty
- One set of Software Notebooks and 90-day Update Service
- Five sets of manuals (for the Operating System)

**NOTE:** No maintenance documentation or diagnostics are provided.

### BASIC SYSTEM PACKAGES

2020-PE 2020-PF	TOPS-20 Basic System Package with an RM03 and Initial Support Package.
2020-PG 2020-PH	TOPS-10 Basic System Package with an RM03 and Initial Support Package.
2020-SE 2020-SF	TOPS-20 Basic System Package with an RP06 and Initial Support Package.
2020-SG 2020-SH	TOPS-10 Basic System Package with an RP06 and Initial Support Package.

## 2020L LICENSE ONLY PACKAGES

### TOPS-10

- KS10 Central Processor
- 256K words MS10 Memory
- One RM03 or RP06 Disk
- LA120 Console Terminal
- 16 Asynchronous Lines
- TOPS-10 Operating System License
- Hardware installation with 90-day warranty

### TOPS-20

- KS10 Central Processor
- 256K words MS10 Memory
- One RM03 or RP06 Disk
- LA120 Console Terminal
- 16 Asynchronous Lines
- TOPS-20 Operating System License
- Hardware installation with 90-day warranty

**A minimum system must include in addition to the license only package, a magnetic tape subsystem with a 1600 bit per inch 9-track tape transport and a line printer.**

**LICENSE ONLY PACKAGES** *(Purchases of License Only Packages require a prerequisite of at least one fully supported Basic System Package.)*

2020L-PE      TOPS-20 License Only Package with an RM03  
2020L-PF      *PREREQUISITE: 2020 Basic System Package*

2020L-PG      TOPS-10 License Only Package with an RM03  
2020L-PH      *PREREQUISITE: 2020 Basic System Package*

2020L-SE      TOPS-20 License Only Package with an RP06  
2020L-SF      *PREREQUISITE: 2020 Basic System Package*

2020L-SG      TOPS-10 License Only Package with an RP06  
2020L-SH      *PREREQUISITE: 2020 Basic System Package*

## 2020 J/K SPECIAL SYSTEM PACKAGES

### System Packages

2020-JE 2020-JF	<sup>1</sup> Special System Package which includes 256K words of memory, two (2) RM03 disk pack drives, 16 asynchronous lines, an LA120 console terminal, the Initial Support Package, 25-Day Consulting Services Package, five (5) Software Units <sup>2</sup> , and the TOPS-20 Operating System <sup>3</sup> .
2020-JG 2020-JH	<sup>1</sup> Special System Package which includes 256K words of memory, two (2) RM03 disk pack drives, 16 asynchronous lines, an LA120 console terminal, the Initial Support Package, 25-Day Consulting Services Package, five (5) Software Units <sup>2</sup> , the TOPS-10 Monitor, and the TOPS-10 Sources <sup>3</sup> .
2020-KE 2020-KF	<sup>1</sup> Special System Package which includes 256K words of memory, two (2) RP06 disk pack drives, 16 asynchronous lines, an LA120 console terminal, the Initial Support Package, 25-Day Consulting Services Package, five (5) Software Units <sup>2</sup> , the TOPS-10 Monitor, and the TOPS-20 Operating System <sup>3</sup> .
2020-KG 2020-KH	<sup>1</sup> Special System Package which includes 256K words of memory, two (2) RP06 disk pack drives, 16 asynchronous lines, an LA120 console terminal, the Initial Support Package, 25-Day Consulting Services Package, five (5) Software Units <sup>2</sup> , the TOPS-10 Monitor, and the TOPS-10 Sources <sup>3</sup> .

### 2020-J/K SPECIAL SYSTEM PACKAGE NOTES

<sup>1</sup>In addition to the basic system package, the minimum system requirement must include a magnetic tape subsystem with 800/1600 bits per inch tape transport and a line printer.

<sup>2</sup>Packages **booked** with 384K words of memory will receive 6 Software Units and packages **booked** with 512K words of memory will receive 8 Software Units. In addition, the 2020 software units must be used at the time of the order.

<sup>3</sup>Includes TOPS-10/20 License.

### MOS MEMORY

MS10-BA      64K words add-on MOS Memory

### ADD-ON DISK PACK DRIVES

RM03-AA      Single access 67.0 megabyte top loading disk pack drive which includes one RM03-P  
*RM03-AD*      disk pack.

RP06-AA      Single access 176.0 megabyte word add-on disk pack drive which includes one RP06-P  
*RP06-AB*      disk pack.

### TAU77 SERIES

#### Magnetic Tape Subsystem

TAU77-EC      Magnetic tape subsystem including a controller and one 9-track master tape drive, 125  
*TAU77-ED*      inches per second, 800/1600 bits per inch (expandable to a maximum of 4 tape drives  
per controller with the addition of the TU77-AF(AJ) add-on tape drive).

## TU77 SERIES

### Add-On Magnetic Tape Drive

TU77-AF 9-track add-on magnetic tape drive 125 inches per second, 800/1600 bits per inch.  
TU77-AJ *PREREQUISITE: TAU77-EC(ED)*

## LINE PRINTERS

LP20-AA 300 lines per minute, LP05 line printer with 64-characters **EDP** drum, 132 columns, LP20  
LP20-AB controller and cable kit.

LP20-AC 300 lines per minute, LP05 line printer with 64-character **Scientific** drum, 132 columns,  
LP20-AD LP20 controller and cable kit.

LP20-BA 240 lines per minute, LP05 line printer with 96-character **EDP** drum, 132 columns, LP20  
LP20-BB controller and cable kit.

LP20-BC 240 lines per minute, LP05 line printer with 96-character **Scientific** drum, 132 columns,  
LP20-BD LP20 controller and cable kit.

LP20-CA 900 lines per minute, LP14 line printer with 64-character **EDP** drum, 132 columns, LP20  
LP20-CB controller and cable kit.

LP20-CC 900 lines per minute, LP14 line printer with 64-character **Scientific** drum, 132 columns,  
LP20-CD LP20 controller and cable kit.

LP20-DA 660 lines per minute, LP14 line printer with 96-character **EDP** drum, 132 columns, LP20  
LP20-DB controller and cable kit.

LP20-DC 660 lines per minute, LP14 line printer with 96-character **Scientific** drum, 132 columns,  
LP20-DD LP20 controller and cable kit.

## CARD EQUIPMENT

CD20-AA 300 cards per minute table reader and controller.  
CD20-AB *PREREQUISITE: DNHXX-A*

CD20-CA 1200 cards per minute console reader and controller.  
CD20-CB *PREREQUISITE: DNHXX-A*

DNHXX-AA Expansion cabinet with BA11-K and the 861 power supply which is used **only** with CD20  
DNHXX-AB card reader.

## COMMUNICATION EQUIPMENT

### Asynchronous Line Multiplexers

- DZ11-AA Asynchronous 8-line multiplexer for EIA terminals or lines which feature programmable speeds (up to 9600 bits per second) and formats on a per-line basis. With the addition of a DZ11-B, this multiplexer can be expanded to a 16-line multiplier that includes a data set control for use with Bell-103 modems or equivalent. Cables are not included.
- DZ11-BA 8-line EIA expansion multiplexer which is required when more than 24 lines are ordered. Cables are not included.  
*PREREQUISITE: DZ11-AA*

### Synchronous Line Interfaces

Synchronous line interfaces operate on 2020/TOPS-20 with DECnet-20 software (QTD20) which must be purchased separately and on 2020/TOPS-10 with TOPS-20 Networks software which is included with the TOPS-10 operating system.

- DN20-BA First synchronous line and controller for speeds between 2.4Kb and 19.2Kb baud (RS-232-C modem interface).
- DN20-BB Second synchronous line interface for speeds between 2.4Kb and 19.2Kb baud (RS-232-C modem interface).

### 2780/3780/HASP COMMUNICATIONS FOR TOPS-20 ONLY

- DN22-AA **IBM 2780/3780/HASP - Multileaving Emulator/Terminator**  
DN22-AB Hardware subsystem including software acting as a remote station to an IBM host in emulation mode, or as a host communicating with 2780, 3780, or HASP multileaving terminals in termination mode. Two communication lines are provided in any mix of emulation or termination. Consult TOPS-20 2780/3780/HASP Software Product Description (SPD 23.7).  
*PREREQUISITE: A DECSYSTEM-2020 running TOPS-20 Release 4 and one DN20-B synchronous line from DECSYSTEM-2020 with either synchronous modems for remote use or a single synchronous null modem for local use. SUBJECT TO CONTROLLED RELEASE PLAN WITH CUSTOMER SERVICES ENGINEERING.*

**Connection of synchronous interfaces such as the DN20 to the DN22 without modems requires the use of a synchronous modem eliminator (a null modem with a clock). DIGITAL does not sell such a device, but one can be obtained from several communications vendors or their representatives. A synchronous modem eliminator, or two modems, must be provided by the customer before any installation can occur.**

### DN200 REMOTE STATION FOR TOPS-10 ONLY

*(See page 31 for configuration.)*

- DN200-AA Remote Station including only the Kernal hardware and console terminal which requires  
DN200-AB the addition of add-on options for operations.  
*PREREQUISITE: DN20*

### DN200 OPTIONS

- DNSXX-AA Synchronous line unit (DMC11-AR/DA) for speeds between 2.4Kb and 19.2Kb baud (RS-232-C interface with cable).  
*PREREQUISITE: DN200-A*

DNSXX-AB Synchronous line unit (DMC11-AR/FA) for speeds between 19.2Kb and 56.0Kb baud.  
*PREREQUISITE: DN200-A*

DNLXX-BA 300 lines per minute. LP05 line printer with 64-character **EDP** drum, 132 columns.  
*DNLXX-BB PREREQUISITE: DN200-A*

DNLXX-CA 230 lines per minute, LP05 line printer with 96-character **EDP** drum, 132 columns.  
*DNLXX-CB PREREQUISITE: DN200-A*

DNCXX-AA 300 cards per minute card reader.  
*DNCXX-AB PREREQUISITE: DN200-A*

**2020**  
**Configurators**  
**&**  
**Rules**

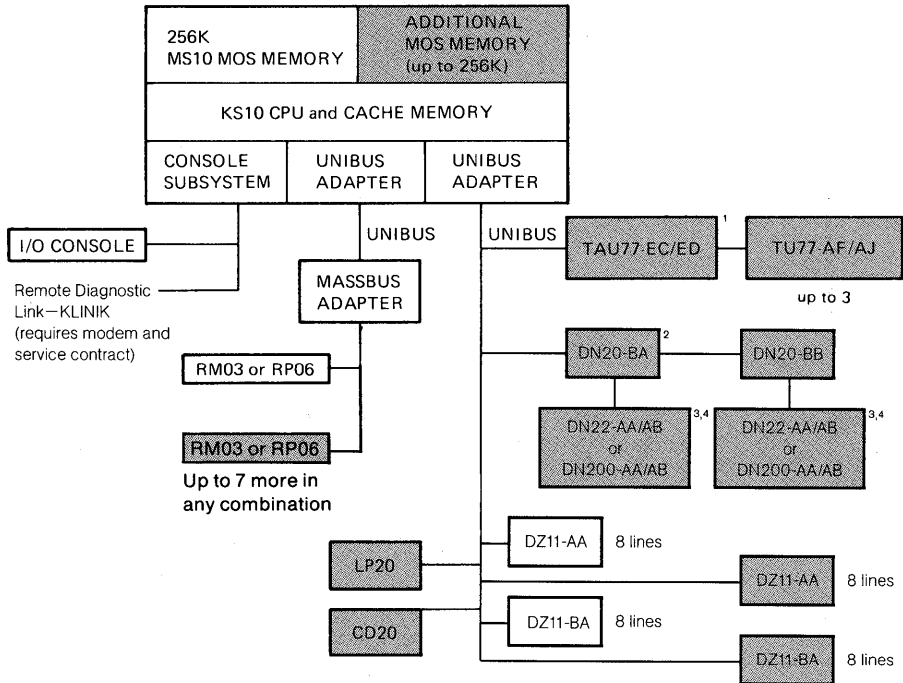
# DECSYSTEM-2020 CONFIGURATOR

## Basic System includes:

CPU, Console Subsystem  
and Cache Memory  
256K Words MOS Memory  
Disk MASSBUS Adapter

RM03 or RP06 Disk Pack Drive  
16 Asynchronous Lines  
LA 120 Console Terminal

A minimum system must include the basic system plus a tape subsystem and a line printer.



## BASIC SYSTEM: SHADED AREA OPTIONAL

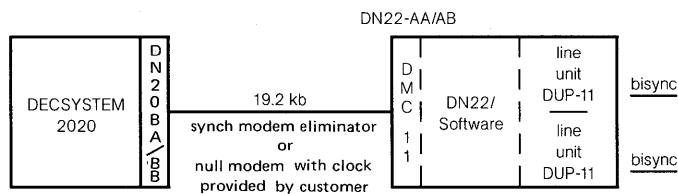
<sup>1</sup>The TAU45 and the TAU77 Magnetic Tape Subsystem cannot be combined on a 2020.

<sup>2</sup>TOPS-10 Network software is included in the Basic System Package. TOPS-20 requires DECnet-20 software (QTD20-XM).

<sup>3</sup>DN22 is for TOPS-20 only.  
DN200 is for TOPS-10 only.

<sup>4</sup>There may be only one DN22 and one DN200 per 2020 system.

## DN22 PRODUCT CONFIGURATION



**DECSYSTEM**  
**2040/2060**  
**Systems & Options**

### 2040 BASIC SYSTEM PACKAGE

- KL10-E Central Processor
- 256K words MF20 MOS Memory
- 2 - RH20 (for disks and tapes)
- One RP06-B Disk
- LA120 Console Terminal
- 16 Asynchronous Lines
- TOPS-20 Operating System (with TOPS-20 License)
- Initial Support Package
- Consulting Services Package (50 days)

### 2060 BASIC SYSTEM PACKAGE

Includes all of the above plus:

- MCA20 Cache Memory

### INITIAL SUPPORT PACKAGE

- Ten Training Credits
- Hardware installation with 90-day warranty
- Software installation with 90-day warranty
- One set of Software Notebooks and 90 days update service
- Five sets of manuals (for the Operating System)

**NOTE:** No maintenance documentation or diagnostics are provided.

**A minimum system must include in addition to the basic system package, a magnetic tape subsystem with a 1600 bit per inch 9-track tape transport and a line printer must be included.**

### BASIC SYSTEM PACKAGES

2040-SC 2040-SD	2040 Basic System Package with Initial Support Package
2060-PE 2060-PF	2060 Basic System Package with Initial Support Package.

### LICENSE ONLY PACKAGES *(Purchases of License Only Packages require a prerequisite of at least one fully supported Basic System Package.)*

2040L-SC 2040L-SD	2040 License Only Package. <i>PREREQUISITE:</i> 2040 Basic System Package
2060L-PE 2060L-PF	2060 License Only Package. <i>PREREQUISITE:</i> 2060 Basic System Package

### MOS MEMORY

MF20-LA MF20-LB	256K words MOS memory with space for 2 MF20-Es, first backplane. <i>(Included in 2060-P system package, shown here for upgrade orders only.)</i>
MF20-LC MF20-LD	256K words MOS memory with space for 2 MF20-Es, second backplane.
MF20-LH MF20-LJ	256K words External MOS memory with space for 1 MF20-E. <i>PREREQUISITE:</i> TOPS-20, Release 4
MF20-E	256K words expansion memory. <i>PREREQUISITE:</i> MF20-L

### 2040L LICENSE ONLY PACKAGE

- KL10-E Central Processor
- 256K words MF20 MOS Memory
- 2-RH20 (for disks and tapes)
- One RP06-B Disk
- LA120 Console Terminal
- 16 Asynchronous Lines
- TOPS-20 Operating System License
- Hardware installation with 90-day warranty

### 2060L LICENSE ONLY PACKAGE

Includes all of the above plus:

- MCA20 Cache Memory

**A minimum system must include in addition to the license only package, a magnetic tape subsystem with a 1600 bit per inch 9-track tape transport and a line printer.**

## MF20 MEMORY CONFIGURATOR

(Number of units of each memory type required for memory size.)

Memory Size (words)	MF20-LA(LB)*	MF20-LC(LD)	MF20-LH(LJ)	MF20-E
256K*	1			
512K	1			1
768K	1			2
1024K	1	1		2
1280K	1	1		3
1536K	1	1		4
1792K	1	1	1	4
2048K	1	1	1	5

\*Memory included in the system package shown here for upgrades only.

## DISK & TAPE CONTROLLER

RH20 MASSBUS controller for disks and tapes.

## ADD-ON DISK PACK DRIVES

RP06-AA Single access 176.0 megabyte add-on disk pack drive which includes one RP06-P disk pack.  
 RP06-AB  
*PREREQUISITE: RH20*

RP06-BA Dual access 176.0 megabyte add-on disk pack drive which includes one RP06-P disk pack.  
 RP06-BB  
*PREREQUISITE: RH20*

RP06-C RP06 dual access kit.  
*PREREQUISITE: RP06-A*

## RP20 SERIES Master Disk Subsystem

RTP20-FA 929MB Fixed media disk unit master subsystem. Includes an RH20 and RP20 Software.  
 RTP20-FB  
*PREREQUISITE: 2040-Sx/2060-Px*

RTP20-FE 929MB Fixed media disk unit master subsystem. Includes an RH20 and RP20 Software.  
 RTP20-FF  
*PREREQUISITE: 2040-Px/2050-Px*

## RP20 SERIES Add-On Disk Units

RP20-AH 929MB Fixed media add-on disk unit TOPS-20 format.  
 RP20-AJ  
*PREREQUISITE: RTP20*

## **RP20 SERIES**

### **Options**

- RTP20-FC      Dual channel option for RTP20 master subsystem.  
RTP20-FD      *PREREQUISITE:* RTP20-FA/FB, FE/FF
- RP20-CA      Dual port option for master subsystem  
*PREREQUISITE:* RTP20
- RP20-CB      Dual port option for add-on disk unit  
*PREREQUISITE:* RP20-A

### **RP20 Cables**

All cables necessary to configure are supplied and are 20 feet long. Other lengths are available at additional charge. Consult the RTP20 Disk System Option Bulletin - Order No. ED 1972526 and the Large Computer Group Price List.

## **TU77 SERIES**

### **Magnetic Tape Subsystem**

- TU77-CB      Magnetic tape subsystem including a controller and one 9-track master tape drive, 125 inches per second, 800/1600 bits per inch (expandable to a maximum of four tape drives per controller with the addition of the TU77-AF(AJ) add-on tape drive).  
TU77-CD      *PREREQUISITE:* RH20

## **TU77 SERIES**

### **Add-On Magnetic Tape Drive**

- TU77-AF      9-track add-on magnetic tape drive 125 inches per second, 800/1600 bits per inch.  
TU77-AJ      *PREREQUISITE:* TU77-CB(CD)

## **TU72 SERIES**

### **Magnetic Tape Controller**

- TX02-EE      Magnetic tape controller and a DX20 channel for TU72 series tapes.  
TX02-EF      *PREREQUISITE:* RH20

## **TU72 SERIES**

### **Add-On Magnetic Tape Drive**

- TU72-EC      9-track add-on magnetic tape drive 125 inches per second, 1600/6250 bits per inch.  
TU72-ED      *PREREQUISITE:* TX02-E

## **TU72 SERIES**

### **Switch Options**

*(See pages 77 through 81 for configurations.)*

- TX03-EE      Two channel switch options and a DX20 channel which includes a BC10Y-25 cable.  
TX03-EF      *PREREQUISITE:* TX02-E; TOPS-20, Release 4
- TX03-FB      Two channel switch options for two (2) TX02s which includes 4 BC10Y-25 cables.  
*PREREQUISITE:* (2) TX02-Es; TOPS-20, Release 4
- TX05-EC      Two control unit tape switch options and a TX02 which includes a BC10X-25, two BC10W-25, and two BC10Y-25 cables.  
TX05-ED      *PREREQUISITE:* TX02-E; TOPS-20, Release 4
- TX05-FB      Two control unit tape switch options which include a BC10X-25 and two BC10W-25 cables.  
*PREREQUISITE:* (2) TX02-Es; TOPS-20, Release 4

## LINE PRINTERS

LP20-AA LP20-AB	300 lines per minute, LP05 line printer with 64-character <b>EDP</b> drum, 132 columns, LP20 controller and cable kit.
LP20-AC LP20-AD	300 lines per minute, LP05 line printer with 64-character <b>Scientific</b> drum, 132 columns, LP20 controller and cable kit.
LP20-BA LP20-BB	240 lines per minute, LP05 line printer with 96-character <b>EDP</b> drum, 132 columns, LP20 controller and cable kit.
LP20-BC LP20-BD	240 lines per minute, LP05 line printer with 96-character <b>Scientific</b> drum, 132 columns, LP20 controller and cable kit.
LP20-CA LP20-CB	900 lines per minute, LP14 line printer with 64-character <b>EDP</b> drum, 132 columns, LP20 controller and cable kit.
LP20-CC LP20-CD	900 lines per minute, LP14 line printer with 64-character <b>Scientific</b> drum, 132 columns, LP20 controller and cable kit.
LP20-DA LP20-DB	660 lines per minute, LP14 line printer with 96-character <b>EDP</b> drum, 132 columns, LP20 controller and cable kit.
LP20-DC LP20-DD	660 lines per minute, LP14 line printer with 96-character <b>Scientific</b> drum, 132 columns, LP20 controller and cable kit.

## CHARABAND LINE PRINTERS

LP200-BA LP200-BB	LP07 <b>Charaband</b> line printer with LP20 controller and cable kit, 900/1200 lines per minute. Specify one or more charabands listed below.
LP07-YA	Charaband containing two sets of <b>EDP</b> 64-character fonts. <i>PREREQUISITE:</i> LP200-B
LP07-YB	Charaband containing two sets of <b>EDP</b> 96-character fonts. <i>PREREQUISITE:</i> LP200-B
LP07-YC	Standard Charaband containing one set of <b>EDP</b> 64-character fonts and one set of <b>EDP</b> 96-character fonts. <i>PREREQUISITE:</i> LP200-B
LP07-YD	Charaband containing one set of 64-character <b>EDP</b> fonts and one set of <b>Kata Kana</b> 49-character fonts. <i>PREREQUISITE:</i> LP200-B
LP07-YF	Charaband containing one set of <b>OCR-A</b> 64-character fonts and one set of <b>OCR-A</b> 96-character fonts. <i>PREREQUISITE:</i> LP200-B
LP07-YH	Charaband containing two sets of <b>Scientific</b> 96-character fonts. <i>PREREQUISITE:</i> LP200-B
LP07-YJ	Charaband containing one set of <b>EDP</b> 96-character fonts and one set of <b>Scientific</b> 96-character fonts. <i>PREREQUISITE:</i> LP200-B
LP07-YK	Charaband containing one set of <b>Swedish/Finnish EDP</b> 96-character fonts. <i>PREREQUISITE:</i> LP200-B
LP07-YL	Charaband containing one set of <b>British EDP</b> 96-character fonts and one set of <b>British EDP</b> 64-character fonts. <i>PREREQUISITE:</i> LP200-B

LP07-YM Charaband containing two sets of **Open Gothic EDP** 64-character fonts (IBM 1401).  
*PREREQUISITE:* LP200-B

### **CARD EQUIPMENT**

CD20-AA 300 cards per minute table reader and controller.  
*CD20-AB*

CD20-CA 1200 cards per minute console reader and controller.  
*CD20-CB*

### **PAPER TAPE**

PC20-CL 300 characters per second paper tape reader/50 characters per second punch which  
*PC20-CM* include a cabinet, power supplies, and a PC04 high-speed PTR/PTP.  
*PREREQUISITE:* DIB20

### **I/O BUS INTERFACE**

DIB20 I/O Bus Interface.

### **FRONT END COMMUNICATIONS**

#### **Asynchronous Line Interfaces**

*(Cables are not included with the DC20 interfaces)*

DC20-AA Basic 8-line interface (DH11-AD) expandable to 16 lines with the addition of the DC20-DA.

DC20-DA 8-line asynchronous expansion interface (maximum of one DC20-DA per DC20-AA).  
*PREREQUISITE:* DC20-AA

DC20-CC Distribution cabinet (required for configuration between 32 and 128 lines).  
*PREREQUISITE:* DC20

DC20-EC Communications expansion cabinet for over 32 lines which includes one DC20-AA (can  
*DC20-ED* accommodate up to three additional DC20-AAs).  
*PREREQUISITE:* DC20-CD

### **DN20 FRONT END COMMUNICATIONS**

#### **Universal Front Ends**

*(See page 54 for configurations.)*

The DN20 is a universal data communications front end. It requires the addition of DN20-XX and DN21-XX options for synchronous operations.

The DN20 universal data communications front ends operate with DECnet-20 (QTD01) or IBM 2780/3780 (QT042) or 2780/3780/HASP (QT052) communications software. Both DECnet-20 and IBM communications software are optional and must be purchased separately. Refer to DECnet-20 (SPD 23.2), TOPS-20 2780/3780 E/T (SPD 23.1) or TOPS-20 2780/3780/HASP (SPD 23.3) SPDs for software descriptions.

Up to two DN20 front ends can be configured per CPU (see DN20 configurator) of which a maximum of one DECnet-20 and one IBM Front End are supported.

DN20-M universal data communications front ends also support the addition of a DN200 remote job entry station for which remote job entry software, RJE-20 (QT062) and DECnet-20 software must be purchased separately. Consult the RJE-20 SPD (SPD 23.6) for a software description.

The DN20-based communications front ends do not include single-device cables to asynchronous terminals or modems. Cables must be ordered separately. (See cable information in the Additional Equipment and Information Section.)

DN20-CA Data Communications Universal Front End with 32K words of core memory and used with  
*DN20-CB* IBM communications (requires the addition of the DN20-xx option for synchronous operations).

- DN20-MA Data Communications Universal Front End with 128K words of MOS memory and used  
 DN20-MB with DECnet-20 Version 2 (requires the addition of DN20-xx or DN21-xx options for syn-  
 synchronous operations).
- DN20-MU Upgrade kit which can expand memory from 32K words core to 128K words MOS.  
 PREREQUISITE: DN20-CA(CB).

**DN20 FRONT END COMMUNICATIONS**  
**Synchronous Line Interfaces**

- DN20-BA Low speed synchronous line controller including one low speed line interface  
 (KMC11/DUP) expandable to 4 lines with the addition of the DN20-BB.  
 PREREQUISITE: DN20-C or DN20-M
- DN20-DA Synchronous expansion drawer including one low speed line interface (KMC11/DUP11)  
 DN20-DB expandable to 4 lines with the addition of the DN20-BA.  
 PREREQUISITE: DN20-BA
- DN20-BB Low speed synchronous line interface (DUP11) for speeds between 2.4Kb and 19.2Kb  
 baud (RS-232-C modem interface).  
 PREREQUISITE: DN20-BA or DN20-DA
- DN21-DA Synchronous expansion drawer including one high speed line DN21-BA interface  
 DN21-DB (DMC11-AR/FA) expandable to 4 lines with the addition of the DN21-BA.  
 PREREQUISITE: DN20-C or DN20-M
- DN21-BA High speed synchronous line interface (DMC11-AR/FA) for speeds between 19.2Kb and  
 56.0Kb baud.  
 PREREQUISITE: DN21-D
- DN21-BB High speed local integral modem synchronous line interface (DMC11-AL/MD) for speeds  
 between 19.2Kb and 56.0Kb baud.  
 PREREQUISITE: DN21-D
- DN21-HA High speed local integral modem synchronous line interface (DMC11-AL/MA) for speeds  
 up to 1Mb baud.  
 PREREQUISITE: DN21-M

**DN200 REMOTE STATION**

*(See page 57 for configuration.)*

- DN200-BA Remote Station including only the Kernal hardware and console terminal which requires  
 DN200-BB the addition of add-on options for operations.  
 PREREQUISITE: DN20

**DN200 OPTIONS**

- DNSXX-AA Synchronous line unit (DMC11-AR/DA) for speeds between 2.4Kb and 19.2 Kb baud (RS-  
 232-C interface with cable).  
 PREREQUISITE: DN200-B
- DNSXX-AB Synchronous line unit (DMC11-AR/FA) for speeds between 19.2Kb and 56.0Kb baud.  
 PREREQUISITE: DN200-B
- DNLXX-BA 300 lines per minute, LP05 line printer with 64-character EDP drum, 132 columns.  
 DNLXX-BB PREREQUISITE: DN200-B
- DNLXX-CA 230 lines per minute, LP05 line printer with 96-character EDP drum, 132 columns.  
 DNLXX-CB PREREQUISITE: DN200-B
- DNCXX-AA 300 cards per minute card reader.  
 DNCXX-AB PREREQUISITE: DN200

## DECSYSTEM-20 UPGRADES

Upgrades are installed in the field and should take a minimum of one (1) to two (2) days depending upon the number of add-ons. The installation price is charged separately on the M.O.F., and the maintenance price will change to reflect the new 2060 system which will exist after the upgrade.

### 2040 to 2060 Upgrade Package\*

- 2060-UA      2040-2060 Upgrade includes Cache Memory (MCA20), and the TOPS-20 Extended Features.
- 2060-UB      2040-2060 Upgrade includes Cache Memory (MCA20), TOPS-20 Extended Features, and the KLPV CPU Upgrade.

### 2050 to 2060 Upgrade Package\*

- 2060-UC      2050-2060 Upgrade includes TOPS-20 Extended Features.
- 2060-UD      2050-2060 Upgrade includes TOPS-20 Extended Features, and the KLPV CPU Upgrade.

\*Contact Field Service to determine if the customer requires the KLPV CPU Upgrade.

## DECSYSTEM-20 MEMORY GUIDELINES

### SYSTEM MEMORY GUIDELINES

#### 2040

- |         |   |            |                     |
|---------|---|------------|---------------------|
| 2040-Px | { | 128-256KW  | MA Only             |
|         |   | 128-384KW  | MA 128KW, MB 256KW  |
|         |   | 128-512KW  | MB20 Only           |
| 2040-Sx | { | 128-1684KW | MA 128KW, MF 1536KW |
|         |   | 256-1792KW | MB 256KW, MF 1536KW |
|         |   | 256-2048KW | MF20                |

#### 2050

- |           |                    |
|-----------|--------------------|
| 128-256KW | MA Only            |
| 128-384KW | MA 128KW, MB 256KW |
| 128-512KW | MB Only            |

#### 2060

- |            |                     |
|------------|---------------------|
| 256-512KW  | MB Only             |
| 256-1792KW | MB 256KW, MF 1536KW |
| 256-2048KW | MF20                |

### MEMORY EXPANSION/EXCHANGE GUIDELINES

In order to expand memory it is sometimes necessary to exchange the old memory type for a newer high-density memory (i.e., the MB memory exchanged for the MF memory).

When an exchange is required to expand memory, all of the memory in a section must be traded in to make room for the new memory. There are typically two sections, A and B, each of which has its own power supply and memory control.

This means that two sections of different memory types may exist in the same processor, however, different memory types cannot be mixed within a section.

A section can have a maximum amount of memory depending on the memory type as follows:

- MA - 128KW
- MB - 256KW
- MF - 768KW

**2040/2060  
Configurators  
&  
Rules**

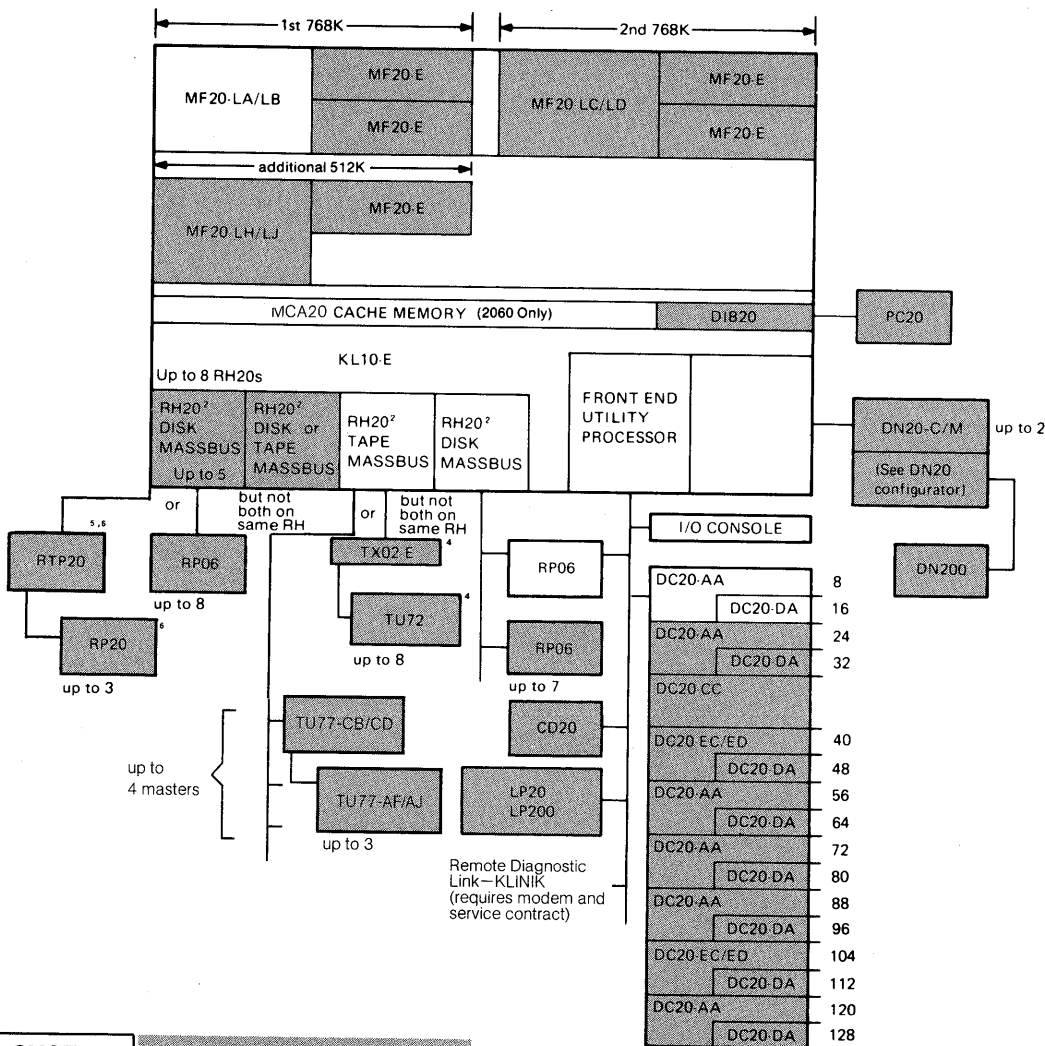
# DECSYSTEM-2040/2060 CONFIGURATOR

## Basic System Includes:

CPU and Front End Processor  
 256K Words MOS Memory  
 Two MASSBUS Controllers  
 for Disks and Tapes  
 LA120 Console Terminal

Cache Memory (2060 Only)  
 RP06 Disk Pack Drive  
 16 Asynchronous Lines

A minimum system must include the basic system package plus a tape subsystem, and a line printer.



**BASIC SYSTEM: SHADED AREA OPTIONAL**

<sup>1</sup>Memory sizes greater than 1536K words require the TOPS-20, Version 4 Operating System.

<sup>2</sup>The system will accommodate up to 8 RH20 MASSBUS channels of which:

- One must be used for the disk to support the dual ported RP06-B system disk that connects to the front end utility processor.
- One must be used for the tape to support the minimum system requirements of at least one 9-track tape drive to a system.
- The remaining six RH20 MASSBUS channels may be used for either disk or tape.

<sup>3</sup>See pages 77 through 81 for additional TX02, TX03, TX05, and TU72 configuration information.

<sup>4</sup>RH20 is included with the RTP20 option (otherwise it is purchased separately).

<sup>5</sup>See pages 73 through 76 for RP20 configuration information.

## DECSYSTEM-20 MAXIMUM STRUCTURE SIZES

	2020	2040	2050	2060
Maximum number of structures per system	8	16	16	16
Maximum structure size (number of RP06s)	2	2	2	3
Maximum structure size (RP20)	N/A	1 Spindle*	1 Spindle*	3 Spindles*

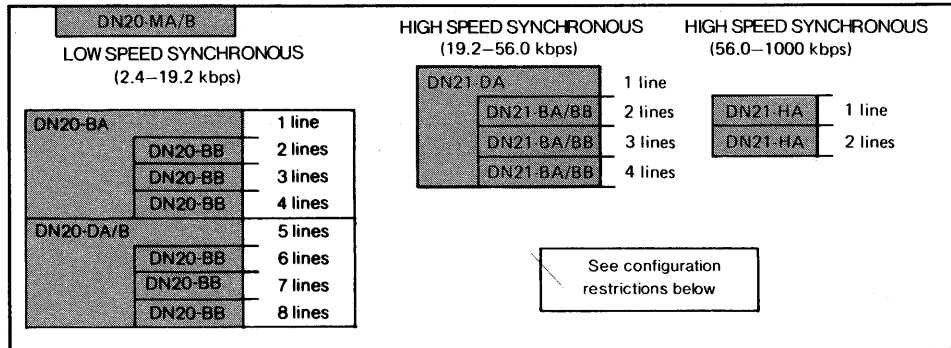
\*There are 2 spindles per RP20 unit (1 spindle = 201K pages)

# DN20 UNIVERSAL COMMUNICATIONS FRONT END CONFIGURATOR

(DECnet-20 and IBM Communications)

Up to two DN20 front ends can be configured per CPU of which one may be for DECnet-20 and one may be for IBM communications.

## DECNET-20 COMMUNICATIONS



**BASIC SYSTEM:** SHADED AREA OPTIONAL

DECnet-20 (QTD01) software must be purchased separately. Consult the DECnet-20 SPD (SPD 23.2) for a software description.

### SYNCHRONOUS OPTION TYPES

#### LINE SPEEDS

2.4- 19.2 Kbps Low Speed Lines

19.2-56.0 Kbps High Speed Lines

56.0- 1000 Kbps High Speed Lines

#### OPTION TYPES

DN20-BA/BB/DA/DB

DN21-BA/BB/DA/DB

DN21-HA

### Configuration Rules

- The number of low speed synchronous lines configured is dependent upon the number of high speed synchronous lines configured.
- There are two ranges of high speed synchronous lines to be considered in the first rule: 19.2-56.0 Kbps (DN21-BA/BB/DA) and 56.0-1000 Kbps (DN21-HA.)

**No High Speed Lines Required**

Up to eight low speed synchronous lines may be configured.

**19.2-56.0 Kbps Lines Required**

**No 56.0-1000 Kbps Lines Required**

Up to four low speed synchronous lines may be configured.

A maximum of four 19.2-56.0 Kbps high speed lines are supported.

**One 56.0-1000 Kbps Line Required**

Up to four low speed synchronous lines may be configured.

One 19.2-56.0 Kbps high speed synchronous line is supported.

**Two 56.0-1000 Kbps Lines Required**

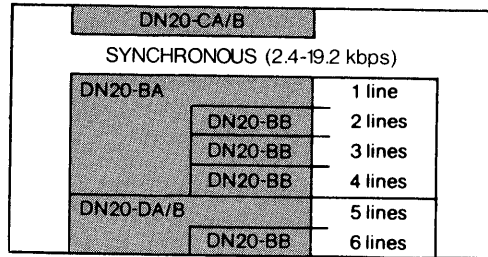
No low speed synchronous lines are permitted.

No 19.2-56.0 Kbps high speed synchronous lines are permitted.

**Summary of Maximum Configurations for DECnet-20 Synchronous Communications**

Maximum Config.	Number of Lines		
	56.0-1000 Kbps HIGH SPEED LINES	19.2-56.0 Kbps HIGH SPEED LINES	2.4-19.2 Kbps HIGH SPEED LINES
A	0	0	8
B	0	4	4
C	1	1	4
D	2	0	0

## IBM COMMUNICATIONS



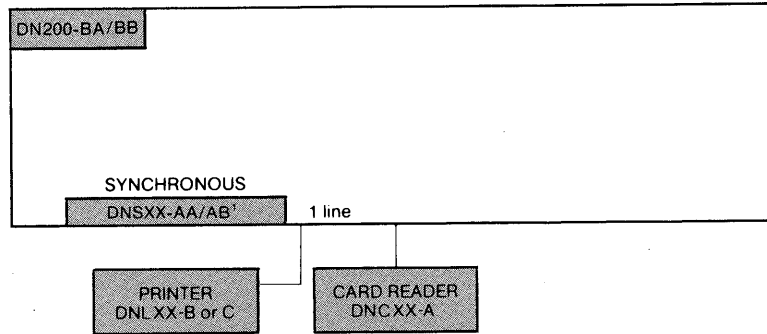
**BASIC SYSTEM:** SHADED AREA OPTIONAL

IBM communications software, TOPS-20 2780/3780 E/T (QT042) or TOPS-20 2780/3780/HASP (QT052), must be purchased separately. Consult the TOPS-20 2780/3780/ E/T SPD (SPD 23.1) and TOPS-20 2780/3780/HASP SPD (SPD 23.3) for software descriptions.

### Configuration Rules

Software Option	Max. No. of Lines	Line Speed (Kilobits/Sec.)	Max. Device Bandwidth (Kilobits/Sec.)
TOPS-20 2780/3780 E/T	6	2.4-19.2	40
TOPS-20 2780/ 3780/HASP			
2780/3780 MODE	4	2.4-19.2	40
HASP MODE	2	2.4-19.2	40

## DN200 CONFIGURATOR



### **BASIC SYSTEM:** SHADED AREA OPTIONAL

The DNSXX-AA/AB is used for connecting to the system. A DN20-BA, BB or DA or DN21-BA, BB or DA is required in the DN20 Front End. Only one synchronous line is supported under TOPS-20.

Connection of synchronous interfaces such as the DN20 to the DN200 without modems requires the use of a synchronous modem eliminator (a null modem with clock). DIGITAL does not sell such a device, but one can be obtained from several communications vendors or their representatives. A synchronous modem eliminator, or two modems, must be provided by the customer before any installation can occur.

DN200 remote job entry stations require RJE-20 (QT062) software and DECnet-20 (QTD01) running in the DN20, both of which must be purchased separately.

A maximum of four DN200s is supported per system, and they must all be configured to the DN20 running DECnet-20.

# **Terminals**

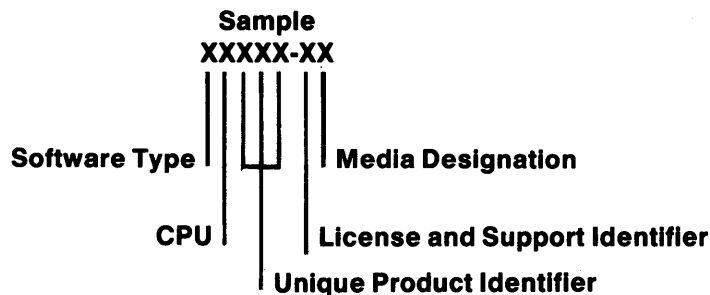
## TERMINALS

- DF01-A Acoustic Telephone Coupler with data rates up to 300 baud, TTY and (RS-232-C) output and half- and full-duplex operations. Used with remote terminals to provide information transfer to/from a Bell 103A3 dataset or equivalent.
- LA38-AA Table-top DECwriter IV printing terminal. Includes universal power supply, standard EIA interface, variable horizontal tabs and margins, four character sizes, six line spacings and printhead adjustment, 18-button numeric keypad, 30-character per second print speed and baud rates up to 300 bits per second. Requires EIA modem or null modem cable or 20mA option.
- LA38-BA Free-standing DECwriter IV printing terminal. Includes stand, universal power supply, standard EIA interface, variable horizontal tabs and margins, four character sizes, six line spacings and printhead adjustment, 18-button numeric keypad, 30-character per second print speed and baud rates up to 300 bits per second. Requires EIA modem or null modem cable or 20mA option.
- LAX34-CL 20mA current loop option for LA38.
- LA120-DA Free-standing high speed interactive hardcopy terminal with contoured typewriter-styled keyboard with n-key rollover. EIA version, 180 characters per second, up to 9600 baud, 7×7 dot matrix, and universal power supply. Requires EIA modem or null modem cable or 20mA option.
- LA12X-AL 20mA conversion kit for LA120.
- VT100-AA  
VT100-AB High performance table-top video display terminal. Double-width/double-size characters, 80 columns × 24 lines or 132 columns × 14 lines, detachable keyboard, line-drawing graphic characters, smooth scrolling, split screen, reverse video or underline character attribute and composite video input/output. The VT100 operates on full-duplex asynchronous communication lines and is supplied with a standard EIA interface. Requires EIA modem or null modem cable or 20mA option.
- VT1XX-AA 20mA current loop adapter for the VT100 which allows a VT100 terminal to connect to a 20mA current loop interface. BC05F-15 cable is included.
- VT1XX-AB Advanced Video Option for the VT100 provides four additional character attributes in any combination; space and connections for an alternate character set memory; and extra screen memory.

# **Software**

## HOW TO ORDER SOFTWARE & SERVICES

The Format of a Software Module Number (Q number) is:



---

### Software Type: Xxxxx-xx

The single character indicates that the option is either System Software (Q) or Diagnostic Software (Z).

### CPU:xXxxx-xx

This single character indicates the Central Processing Unit on which the software is used. The following codes have been assigned:

**QHxxx-xx** identifies TOPS-10 Software

**QTxxx-xx** identifies TOPS-20 Software

### Unique Product Identifier:xxXXX-xx

Therefore, the first five characters (QHxxx or QTxxx) indicate the product code. For example, QH500 stands for FORTRAN-10, and QT001 stands for FORTRAN-20.

### License and Support Identifier:xxxx-Xx

This single character indicates the type of license and support service the option carries. Code assignments are as follows:

- 1 = Additional Dispatch Subscription.
- 3 = Self-Maintenance Service for Software.
- A = Single-use license, binaries, documentation, support services.
- C = Single-use license, binaries, documentation, no support services.
- D = Single-use license only, no binaries, no documentation, no support services.
- E = Sources license, sources, no support services.
- H = Out-of-warranty binaries update, documentation, no support services.
- K = Subscription/maintenance service.
- N = Out-of-Warranty sources update, no support services (may also contain binaries).
- X = Single-use license, sources license, sources or sources and binaries, documentation, support services.
- Y = Same as "X", only no support services.

## Media Designation:xxxx-xX

This single character identifies the Distribution Media. The following codes have been assigned:

Media type	Value of "x"	Where used
9-track tape, 800 bpi	P	TOPS-10 software only
9-track tape, 1600 bpi	M	TOPS-10 or TOPS-20 software
RP04-P	K	Front end source code only
RP06-P	L	Front end source code only
Microfiche	R	Software Dispatch
Paper	Z	Software Dispatch, Notebooks and Notebook Updates

### Software Examples

Distribution/Support	TOPS-10	Maint. Svcs	TOPS-20	Maint. Svcs
Binaries only, supported	QHxxx-Ax	QHxxx-3x <sup>1</sup>	QTxxx-Ax	QTxxx-3x <sup>1</sup>
Binaries and/or Sources supported	QHxxx-Xx	QHxxx-3x <sup>1</sup>	QTxxx-Xx	QTxxx-3x <sup>1</sup>
Binaries only, unsupported	QHxxx-Cx	-	QTxxx-Cx	-
Sources only, unsupported	QHxxx-Ex	-	QTxxx-Ex	-
Notebooks & Notebook updates/Dispatch	-	QHxxx-Kx	-	QTxxx-Kx
Binaries & Sources unsupported	QHxxx-Yx	-	QTxxx-Yx	-
Additional software DISPATCH subscription	-	QHxxx-1x	-	QTxxx-1x
Source Update Kit	-	QHxxx-Nx	-	QTxxx-Nx
Out of Warranty Binary Update Kits	-	QHxxx-Hx <sup>2</sup>	-	QTxxx-Hx <sup>2</sup>
License to Copy	QHxxx-Dz <sup>3</sup>	-	QTxxx-Dz <sup>3</sup>	-
Right to Copy Updates	-	QHxxx-Hz	-	QTxxx-Hz
	-	QHxxx-Nz	-	QTxxx-Nz

<sup>1</sup>Applies to Operating System Maintenance Services only.

<sup>2</sup>With the exception of certain components of TOPS-10.

<sup>3</sup>Not applicable to operating system software except in License only packaged systems ("L" series).

TOPS-10 software is available on two different kinds of tape. TOPS-20 software is available only on 9-track tape, 1600 bits per inch (media type "M"). Front end source code is available only on RP04 and RP06 disk packs (codes K, L). The front end cannot access tape drives.

## OPTIONAL SOFTWARE PACKAGES

### SOURCES

There are three source policy codes used in the following tables:

1. B, S - Binaries and sources are shipped with the product.
2. B, S# - Binaries and sources are shipped with the product, even though the Software Product Description (SPD) for the product indicates that sources are not shipped. In this case, the sources are intended for use by the customer only as a product support tool.
3. B - No sources are shipped with the product. In this case, the customer may purchase the sources from DIGITAL.

The appropriate source policy is indicated by product in the source policy column.

TOPS-10	TOPS-20	Description	SW <sup>1</sup> Units	Source Policy	
				TOPS-10	TOPS-20
<b>1090 SYMMETRICAL MULTI-PROCESSING (SMP)</b>					
QH302-Xx		TOPS-10 SMP support for Dual 1090 (Prerequisite is TOPS-10 License M9301-W bootstrap - See 1090 Section)		B,S	
<b>COMMUNICATIONS SOFTWARE (Supported)</b>					
QH603-Xx		2780/3780 Software V7.01 for DECsystem-10	1	B,S	
QH682-Xx		DECnet-10 (DCP) Task-to-Task		B,S	
	QT042-Xx	2780/3780 Software (2040,2050,2060)	1		B,S
	QT052-Xx	2780/3780/HASP			B,S
	QTD01-Ax	DECnet-20 (2040, 2060)	1		B <sup>2</sup>
	QTD20-Ax	DECnet-20 (2020)	1		B <sup>2</sup>
	QT062-Ax	RJE-20	1		B <sup>2</sup>

<sup>1</sup>Apply only to the 2020-J/K Special System Packages.

<sup>2</sup>Sources not available at this time.

TOPS-10	TOPS-20	Description	SW <sup>1</sup> Units	Source Policy	
				TOPS-10	TOPS-20
<b>LANGUAGES AND DATA MANAGEMENT (Supported)</b>					
QH500-Xx	QT001-Ax	FORTRAN (ANS-66 compiler)	1	B,S	B,S#
QH502-Xx	QT002-Ax	ALGOL (ALGOL-60 compiler)	1	B,S	B,S#
QH503-Xx		BASIC-10	1	B,S	
	QT027-Ax	BASIC-PLUS-2	1		B
QH300-Xx	AT007-Ax	SORT-MERGE	1	B,S	B,S#
QH099-Xx	QT099-Ax	COBOL-68/74 (ANS-74) compiler plus COBOL-68 with SORT/MERGE	1	B,S	B,S#
QH101-Ax	QT008-Ax	DBMS (Includes 2 training credits)	3	B	B
QH045-Ax	QT016-Ax	IQL, Interactive Query Language (Extended version, with DBMS interface, and both ISAM and sequential)	2	B,S#	B,S#
QH020-Xx		MCS-10 Message Control System <sup>1</sup>		B,S	
	QT037-Ax	TRAFFIC-20	1		B,S#
QH072-Ax	QT014-Ax	APL (Basic Version) (Same as APLSF, but with no file input- output)	1	B	B
QH071-Ax	QT012-Ax	APLSF (APL with system functions)	2	B	B
QH060-Ax	QT009-Ax	CPL Conversational Program Language (ANS-76 PL/I subset interpreter)	1	B	B
QH115-Ax	QT115-Ax	BLISS-36		B	B

<sup>1</sup>Apply only to the 2020-J/K Special System Packages.

TOPS-10	TOPS-20	Description	Source Policy	
			TOPS-10	TOPS-20
<b>LICENSE UPGRADES</b>				
QH074-Ax	QT025-Ax	APL (Basic) to APLSF	B	B
QH076-Ax		APL-E and APL-F to APL-SF	B	
	QT028-Ax	BASIC to BASIC-Plus-2		B
QH509-Xx	QT024-Ax	SORT/MERGE to COBOL-68/74 with SORT/MERGE		B
QH512-Xx	QT047-Ax	COBOL-68/74 with SORT/MERGE Upgrade from 68	B	B
	QT054-Xx	2780/3780 to 2780/3780/HASP	B	B
<b>SUPPORT SERVICES</b>				
QHK20-KZ	QT018-KZ	Software Notebook Set (Includes one year of update service.)	N/A	N/A
QHK14-3Z	QT018-3Z	Software Notebook Update Service	N/A	N/A
QHK12-1Z	QT021-1Z	Additional Software DISPATCH subscription (paper)	N/A	N/A
QHK12-1R		Additional Software DISPATCH subscription (fiche)	N/A	N/A
<b>MISCELLANEOUS UNSUPPORTED SOFTWARE</b>				
	QT004-Cx	BASIC-20		B,S
<b>SOURCES (UNSUPPORTED)</b>				
All source packages require the corresponding binary package.				
	QT030-Ex	TOPS-20 Monitor Sources		S
	QT038-Ex	TOPS-20 Exec Sources		S
	QT029-Ex	TOPS-20 Front End Sources		S
	QT040-Ex	TOPS-20 Source Package (Includes QT030, QT029, QT038)		S
QH666-Ex		TOPS-10 Front End Sources	S	
	QT120-EM <sup>1</sup>	TOPS-20/RP20 Monitor Sources		S

<sup>1</sup>Available only after purchase of TOPS-20 Monitor Sources (QT030 or QT040).

TOPS-10	TOPS-20	Description	Source Policy	
			TOPS-10	TOPS-20
<b>MICROCODE AND DIAGNOSTICS (UNSUPPORTED)</b>				
QH850-Yx	QT850-Yx	KL 10 Microcode Source Code	B,S	
ZH009-Cx	ZH009-Cx	KL 10-A/B Maintenance Product	B	
ZH006-Cx	ZH006-Cx	KL 10C Maintenance Product		B
ZH007-Cx	ZH007-Cx	KL 10D Maintenance Product		
ZH008-Cx	ZH008-Cx	KL 10E Maintenance Product	B	B
ZH010-Cx	ZH010-Cx	10/20 Maintenance Product ZH006 to ZH009 Upgrade		
QT046-Yx	QT046-Yx	KS 10 Microcode Product	B	B
	ZT001-Yx	2020 Diagnostics	B	B

**OTHER LANGUAGE PRODUCTS AVAILABLE (CONTACT YOUR SALES REPRESENTATIVE)**

**Language**

COGO

PCS

GIGI

SITGO

SITBOL/SNOBOL

# **Additional Equipment & Information**

## DC20, DN20 and DZ11 COMMUNICATIONS CABLING

On an individual basis each asynchronous line may be either local EIA or EIA with full modem control. By the use of an H313-A TTY voltage/current adapter, an EIA local line may terminate a 20mA current mode terminal. This difference is transparent to the communications hardware and is determined solely by the type of cable attached to the DN25, DC20-AA, DC20-DA, or DZ11. Therefore, it is extremely critical that the correct type of line is ordered.

### FULL MODEM CONTROL LINES

- For each full modem control line specified, a BC05D-25 (25 foot) cable must be ordered.
- If a 25-foot cable is not long enough, an additional BC05D-25 cable per line may be ordered as a separate line item. Two is the maximum number of BC05D-25 cables that may be joined.

### LOCAL LINES

- For each local EIA line specified, a BC03M-A0 (100-foot) cable must be ordered.
- The H313-A is not included; which means that in order to support a 20mA current loop terminal, the appropriate number of H313-As must be ordered as a separate line item, (one H313-A per line) at the current price.
- If the 100-foot (BC03M-A0) local EIA cable is not long enough, then either longer cables must be ordered as separate items at current prices, or cables may be customer built to DIGITAL supplied specifications (available from Field Service).

### 20mA CURRENT MODE TERMINAL SUPPORT

- The DC20, DN25, and DZ11 internal hardware is EIA and it supports EIA lines and terminals only.
- When cable length requirements for local terminals are in excess of the published capabilities (1000 feet at up to 2400 baud and 250 feet at up to 9600 baud), then EIA short-haul modems or the use of dial-up is required. The 20mA current mode is not supported for longer distances than the EIA, because the transmission must be all EIA and not current mode.
- All new terminals ordered with or for systems must be EIA.
- Most terminal vendors provide a field upgrade to convert current mode terminals to EIA terminals.
- When it is necessary to attach a current mode terminal to a system - this should only be when the customer has an installed current mode terminal which is non-field convertible to EIA - then an H313-A can be ordered. Remember that this only converts EIA to/from current mode; the terminal must still be operated within the published EIA length specifications and the H313-A must be within 25 feet (7.5m) of the terminal.
- The H313-A works at any power frequency in the 50 to 500 hertz range but works only with 120 volt power. Customers in countries which do not use 120 volt power will be required to supply their own step-down transformer from 240 volt to 120 volt. Local Field Service has the specifications for the required transformer.

### TERMINAL CABLING

All terminals equipped with the 20mA current loop interface will be supplied with a cable terminated with a 4-pin telephone plug connector unless otherwise specified. Conversely, all terminals equipped with an EIA interface will be supplied with a cable that is terminated with a 25-pin dataset connector.

BC11S-25	Cable, H856 to H856, 18 twisted pair, for use with the LA180.
BC03M-xx	Null modem cable allows local connection of asynchronous interfaces or terminals having EIA interfaces. The following lengths are available: 25 ft. (7.6m), 100 ft. (30.5m), 250 ft. (76.2m), 500 (152.4m), 1000 ft. (304.8m) cable (3 shielded twisted pair) with two DB25S sockets.
BC05D-xx	EIA extension cable for use with cinch DB25S socket and DB25P plug. The following lengths are available: 10 ft. (3.0m) and 25 ft. (7.6m).

## Cable Specifications

Line Type	Local EIA	EIA with Full Modem Control	Local 20mA Current Loop																					
Line Usage	Direct attachments to EIA terminals	Direct attachments to EIA dial-up or non-dial up modems. The modems must have user interfaces which meet EIA RS-232-C interface type E (i.e., Bell 103-A type interface compatible).	Direct attachments to Local Current Loop terminals																					
Maximum Cable Length	1000 ft. if terminal speed is 2400 baud. 2500 ft. if terminal speed is 9600 baud.	50 feet	max. length computer to H313-A 1000 ft. @ 2400 baud  250 ft. @ 9600 baud  max. length H313-A to terminal 25 ft.																					
	<table border="1"> <thead> <tr> <th>BAUD</th> <th>SHIELDED (IN FEET)</th> <th>UNSHIELDED (IN FEET)</th> </tr> </thead> <tbody> <tr> <td>110</td> <td>5000</td> <td>3000</td> </tr> <tr> <td>300</td> <td>5000</td> <td>3000</td> </tr> <tr> <td>1200</td> <td>3000</td> <td>3000</td> </tr> <tr> <td>2400</td> <td>1000</td> <td>600</td> </tr> <tr> <td>4800</td> <td>1000</td> <td>250</td> </tr> <tr> <td>9600</td> <td>250</td> <td>250</td> </tr> </tbody> </table>			BAUD	SHIELDED (IN FEET)	UNSHIELDED (IN FEET)	110	5000	3000	300	5000	3000	1200	3000	3000	2400	1000	600	4800	1000	250	9600	250	250
BAUD	SHIELDED (IN FEET)	UNSHIELDED (IN FEET)																						
110	5000	3000																						
300	5000	3000																						
1200	3000	3000																						
2400	1000	600																						
4800	1000	250																						
9600	250	250																						
	<p>All distances shown are more than 50 feet/2500ft. hence these transmissions violate RS-232-C.</p> <p>Note that in the "EIA" interface case, shielded pair outperformed unshielded wire.</p>																							
Cable Type	one BC03M-xx per line	one BC05D-25 per line	one BC03M-xx plus one H313-A per line																					
Cable Specification for customer desired length	BC03M-25 25 ft. BC03M-A0 100 ft. BC03M-B5 250 ft. BC03M-E0 500 ft. BC03M-LO 1000 ft.	BC05D-25 25 ft. for 50 ft. use two (max.) joined together	BC03M-25 25 ft. BC03M-A0 100 ft. BC03M-B5 250 ft. BC03M-E0 500 ft. BC03M-LO 1000 ft. plus one H313-A line																					
Notes	BC03M cables cannot not be joined for length extension purposes		Requires one desired length BC03M cable plus one H313-A per line																					

## TX02/03/05 CABLING

The TX02, TX03 and TX05 cable options are supplied in 25 foot standard lengths. Longer lengths are available at additional charge, 90 days ARO.

- BC10X-xx Emergency power-off cable. Used with the TX02s and the TX05s. The following lengths are available: 25 ft. (7.6m), 50 ft. (15.2m), 75 ft (22.9m), and 100 ft. (30.5m).
- BC10Y-xx IBM bus or tag. Used with the TX02s and the TX05s. The following lengths are available: 25 ft. (7.6m), 50 ft. (15.2m), 75 ft. (22.9m), and 100 ft. (30.5m).
- BC10W-xx Communication cable for the TX05 connector switches. The following lengths are available: 25 ft. (7.6m), 50 ft. (15.2m), 75 ft. (22.9m), and 100 ft. (30.5m).
- BC10Z-xx Channel Bus cable (DX20). The following lengths are available: 25 ft. (7.6m), 50 ft. (15.2m), and 75 ft. (22.9m).
- BS10B-xx Drive bus power and signal cable set used on TX02s. The following lengths are available: 25 ft. (7.6m), 35 ft. (10.6m), and 50 ft. (15.2m).

## STANDARD 2020 CABLES

From	To	Length
KS10	LP*	25 ft.
KS10	RM03	25 ft.
KS10	RP06	15 ft.
KS10	TAU45	15 ft.
RP06	RP06	2/25 ft.
RM03	RM03	15 ft.
KS10	LA120	25 ft.
KS10	MODEM or TERMINAL	25 ft.

\*This cable is available at an additional charge.

## LINE PRINTER

- 70-11426-A0 Optional 100-ft. (30.5m) line printer cable.  
*PREREQUISITE: LP20*

## RTP20 DISK SYSTEM CONFIGURATIONS

The RP20 is a fixed (nonremovable) media disk. Each CPU can be configured with up to 24 of these units giving a total capacity of over 20 billion bytes of online RP20 storage. Each disk unit consists of two data modules (spindles) which operate independently and can transfer data simultaneously when the optional dual-ported feature is employed. Each data module has fifteen recording surfaces with two read/write heads per surface and a transfer rate of 1.2 megabytes per second.

The RTP20 Master Subsystem includes an RH20 Massbus Channel, DX20 Massbus Adapter, RP20 Controller, and formatted Master Disk Unit. Each RTP20 Master Subsystem can control up to three additional RP20 add-on disk units.

The RH20 Massbus Channel is the interface between the KL10 Central Processor and the Massbus which connects to the DX20. The RH20 is housed in the CPU cabinet.

The DX20 is a microprocessor-based adapter which interfaces the Massbus to the disk controller. The RP20 Disk Unit and tapes cannot be connected to the same DX20.

The RP20 Control Unit is an advanced Read/Write memory microprocessor. When loaded from its self-contained, flexible disk drive, it offers off-line diagnostics, a full function front-end panel, and a two-channel switch option.

## OPTIONS

### Dual Port Option

The dual port option allows a disk unit to be accessed from two RTP20 Master Subsystems. The dual port option requires two master Subsystems and a Dual Port feature on *all* disk units in the configuration. Each subsystem may be fully configured with four disk units. A total of eight disk units (two masters and six add-ons) may be configured. See the Dual Port Configuration for operating restrictions.

### Dual Channel Option

The Dual Channel option allows an RP20 string to be connected to two channels. Only one path at a time may be active and is selected by a manual switch in the RP20 Controller.

## CONFIGURATIONS

*(See figures 1 through 4.)*

### Single Port Configurations

The Single Port configuration (Figure 1) consists of an RTP20 Master Subsystem. Additionally, the Master Disk Unit contains the control functions necessary to operate up to three RP20 add-on units. Therefore, the maximum number of disk units supported in this configuration is four.

### Dual Port Configuration

The Dual Port configuration (Figure 2) provides enhanced performance and greater configuration flexibility. This configuration allows each disk unit to be connected to two RP20 Subsystems. The Dual Port configuration requires two RTP20 Master Subsystems. Up to six add-on units may be added to this configuration. All disk units in this configuration must contain a dual port option.

The DECsystem-10 uses the Dual Port option dynamically. This means that transfers may be initiated through either of the control units. The operating system selects the path which optimizes overall performance. If a control unit is turned off-line, all transfers automatically are switched to the other. This provides both load balancing and alternate path selection for improved availability. On a dual SMP system, the control units may be on different CPUs.

The DECSYSTEM-20 provides manual Dual Porting with static load balancing. This means that a disk unit may be manually switched to operate through one control unit or the other but not both. If the switch setting allows access from both control units, the operating system will assign each data module in a disk unit to a separate control unit at a system startup time. This provides static load balancing and improved performance.

### Dual Channel/Single Port Configuration

The Dual Channel Master Subsystem (Figure 3) consists of an RTP20 Master Disk System and a Dual Channel Option. The master disk unit contains the control functions necessary to operate up to three RP20 add-on units. Thus, the maximum number of disk units supported by the Dual Channel Master Subsystem is four. This configuration provides dual access from a single or two processors and is generally requested when a user desires to share a data base between two systems either for convenience or availability. Only manual operations of a dual channel configuration are supported, and the channel may only be switched to one CPU at a time.

### Dual Channel/Dual Port Configuration

The Dual Channel/Dual Port configuration (Figure 4) is a combination of the previously described Dual Channel configuration and Dual Port configuration. The maximum number of disk units is the same as for the dual port configuration.

This configuration provides redundancy for high availability environments. Users requesting this configuration are generally trying to keep downtime to a minimum by utilizing redundancy design throughout the entire computing system.

### System Configuration Notes

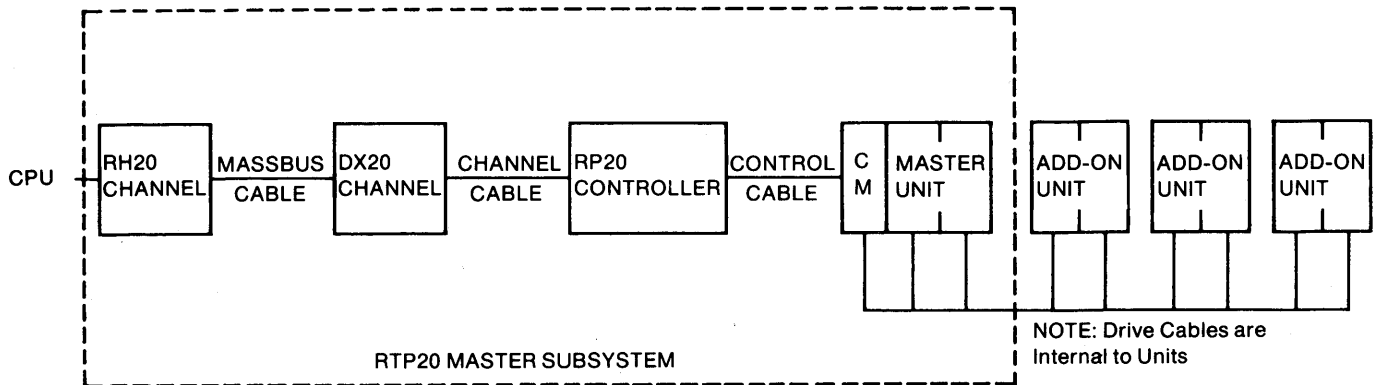
- There may be only one RTP20 per RH20 channel.
- An RTP20 cannot share an RH20 with any other device.
- Up to six RTP20 channels per CPU (giving a maximum of 24 disk units) are available.
- There is a maximum of eight RH20 channels on a KL10 CPU. At least one must be reserved for RP06s, and at least one must be reserved for tape.
- An RP20 cannot be used as the front-end device. There must be at least one RP06 to meet this need.

### CABLES

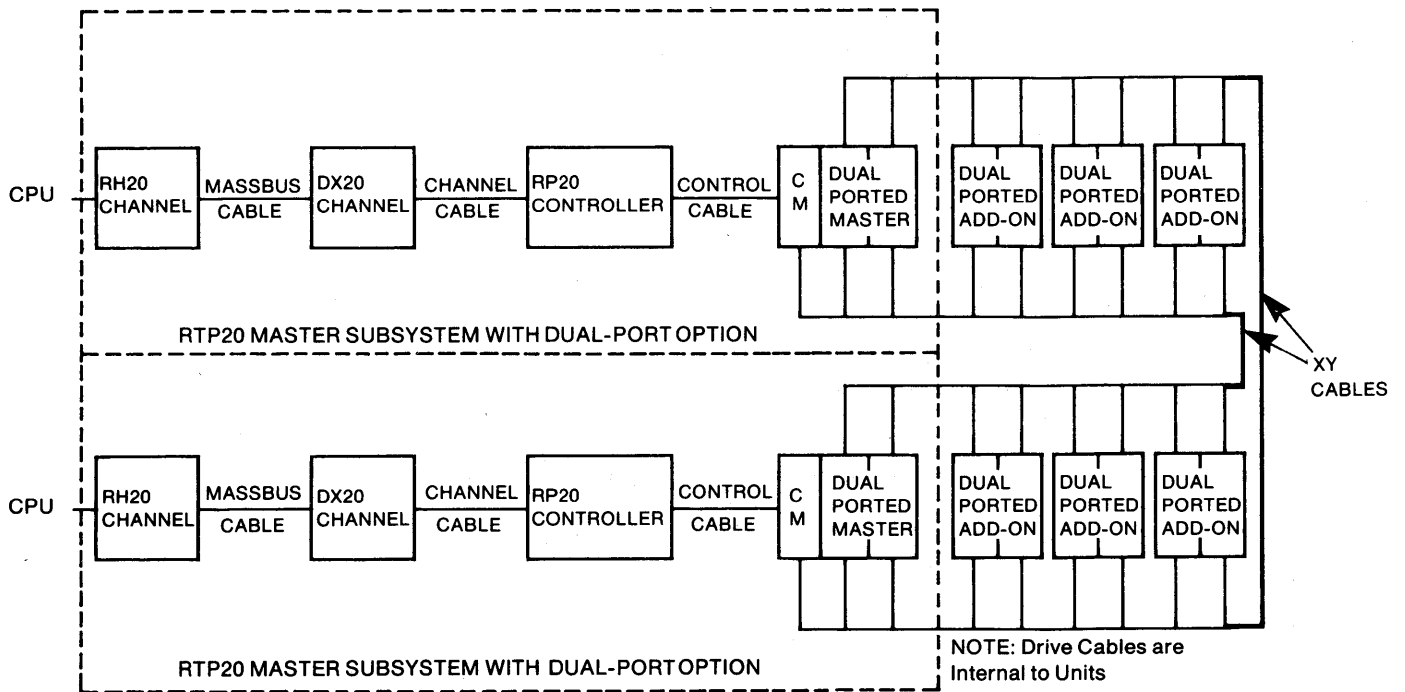
Cable	Description	Maximum Length
BC06S	Massbus Cable	39m (130 ft)
BC10X	Emergency Power-Off Cable	30m (100 ft)
BC10Z	Channel Cable	30m (100 ft)
BC10S	Control Cable	30m (100 ft)
BC10R	XY Cable	12m (40 ft)

(1) Cables supplied are 20 feet long. Other lengths are available at additional charge.

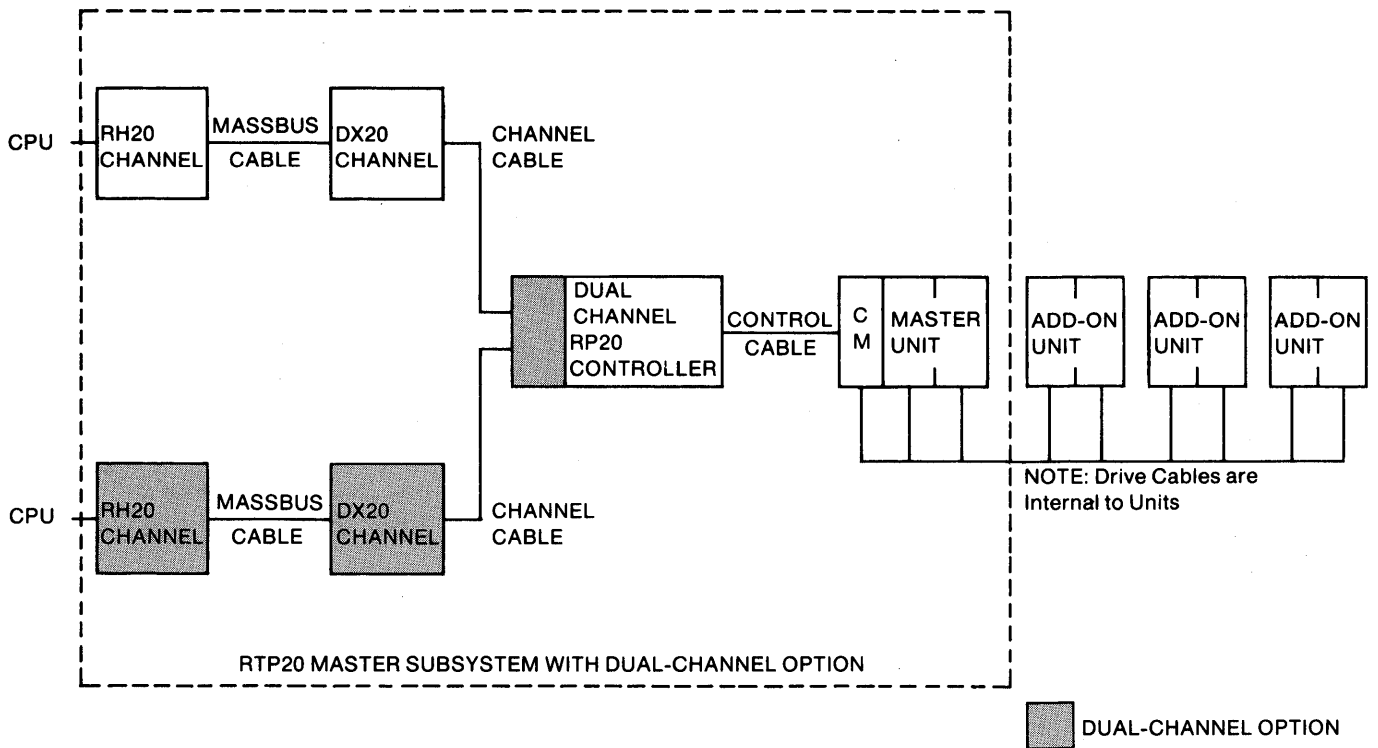
(2) All add-on units are manufactured with internal signal and power buses.



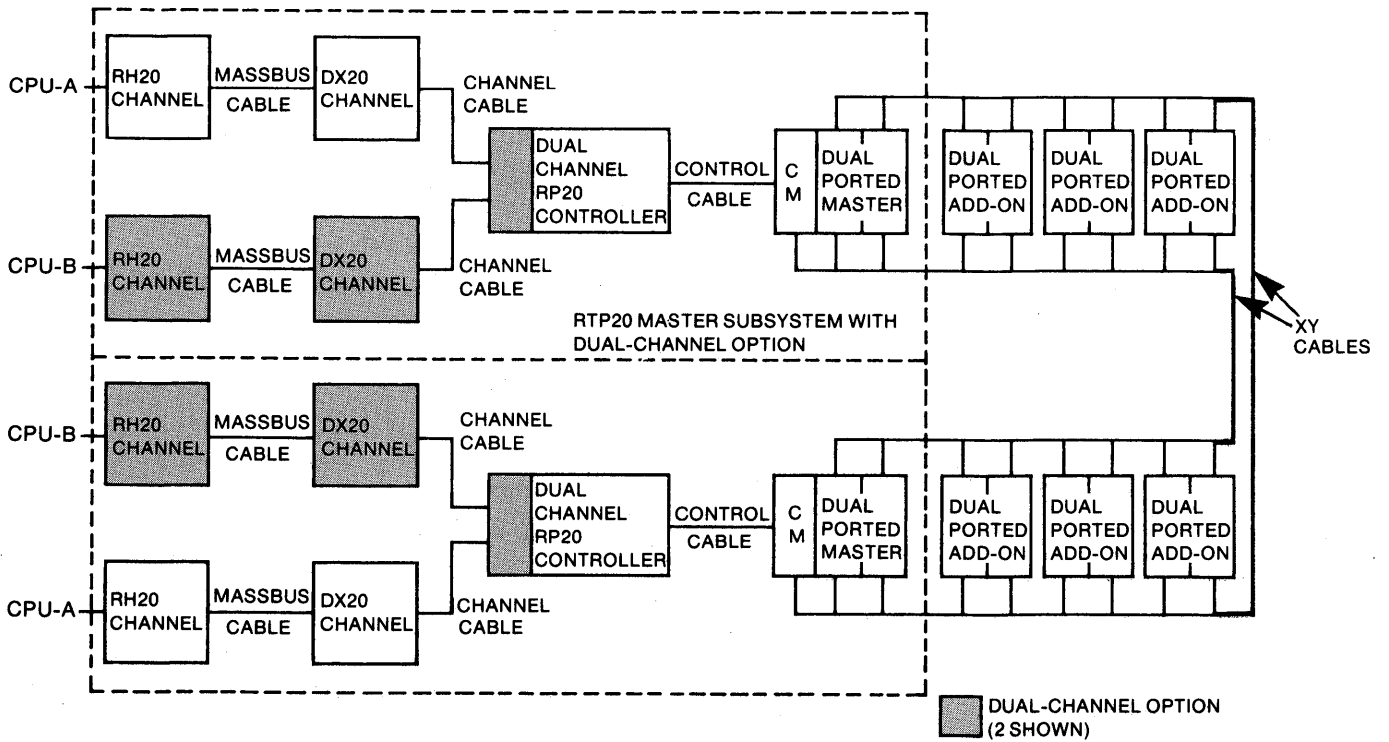
**Figure 1**  
**Single-Port Configuration**



**Figure 2**  
**Dual-Port Configuration**



**Figure 3**  
Dual-Channel, Single-Port Configuration



**Figure 4**  
Dual-Channel, Dual-Port Configuration

## TU72 SERIES MAGNETIC TAPE DRIVE CONFIGURATIONS

A system may consist of one or more TU72 drives, up to a maximum of eight drives with any combination of TU72 or a previously offered tape TU70 or TU71 drives, a TX02 tape control unit, and a DX20 data channel.

The tape control unit connects to each drive using radial cabling. The DX20 data channel connects directly to the internal data channel (RH20) of the mainframe.

TOPS-20 Release 3A or later supports one DX20 with one TX02, and up to eight tape drives (TU70, TU71, TU72) per channel. A TOPS-10 LIR under Release 6.03A or later supports the DX20/TX02 subsystem. TX03 and TX05 switches are supported configurations when there is a close operator control over one channel at a time. These configurations are not supported when both channels are enabled.

### TX03 Two Channel Switch

The TX03 is a dual-ported switch which allows the user to interface between the two data channels, one control unit, and up to eight drives. It allows access to all tape drives available to the TX02.

### TX05 Two Control Unit Switch

The TX05 is essentially a drive switch and allows interface operations between two data channels, two control units, and up to 16 tape drives.

The TX05 switch enables a tape drive which is physically attached to one tape controller to be controlled by a second tape controller. This is accomplished by two communicator cables which connect the two TX02s via the TX05 option. Switch panels (which contain two rows of eight switches each and are provided with the TX05 option) enable access to individual drives to be manually enabled/disabled from either controller.

## Configurations

**Figure 5** shows the Single-Channel basic configuration. Up to eight tape drives can be accessed.

**Figure 6** shows the Dual-Channel configuration for dual access from one or two processors. Generally requested when a user would like to share tape drives between two processors (manual operation only).

**Figure 7** shows the Single-Channel Extended configuration with the tape drives available extended to 16.

**Figure 8** shows the Dual-Channel/Two Control Unit for tape sharing and redundancy from two processors. Either channel can access a bank of drives through either control unit via the TX03 control unit switch. This configuration is requested when a user with two processors wants to share tape drives and also have a high-availability tape system to assure uptime (manual operation only).

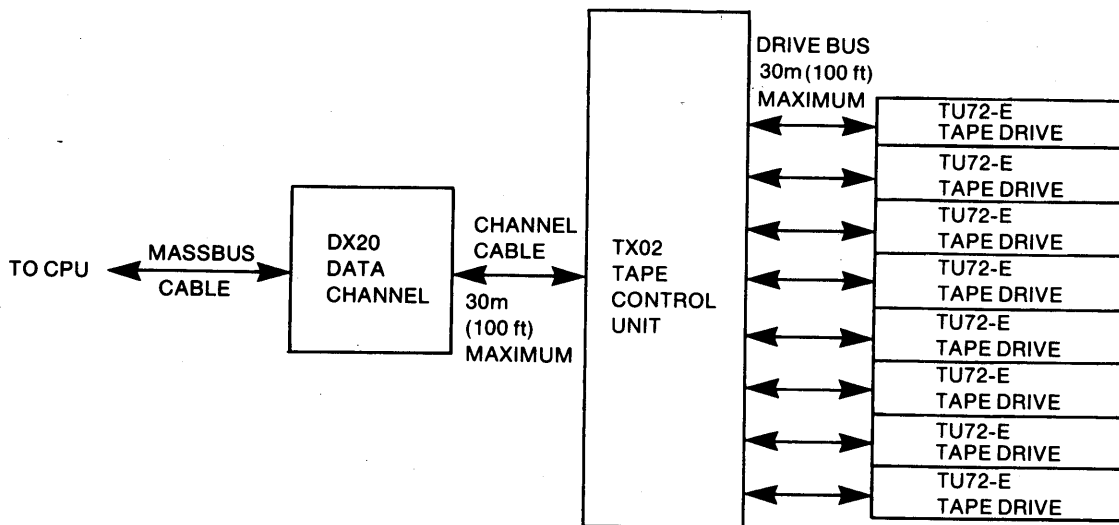
**Figure 9** shows the Two-Channel/Dual Control Unit for tape sharing and redundancy from two processors which allows specific tape drive selection for either processor by switches available with the TX05 option. Each channel can access designated tape drives through its associated control unit via the TX05 option.

**Figure 10** shows the Dual-Channel/Dual Control Unit for tape sharing and dual redundancy in high-availability environments. Either channel can access tape drives through multiple paths. Users requesting this configuration are generally providing timesharing services and are trying to keep downtime to a minimum by utilizing redundancy design throughout the entire computing system (manual operation only).

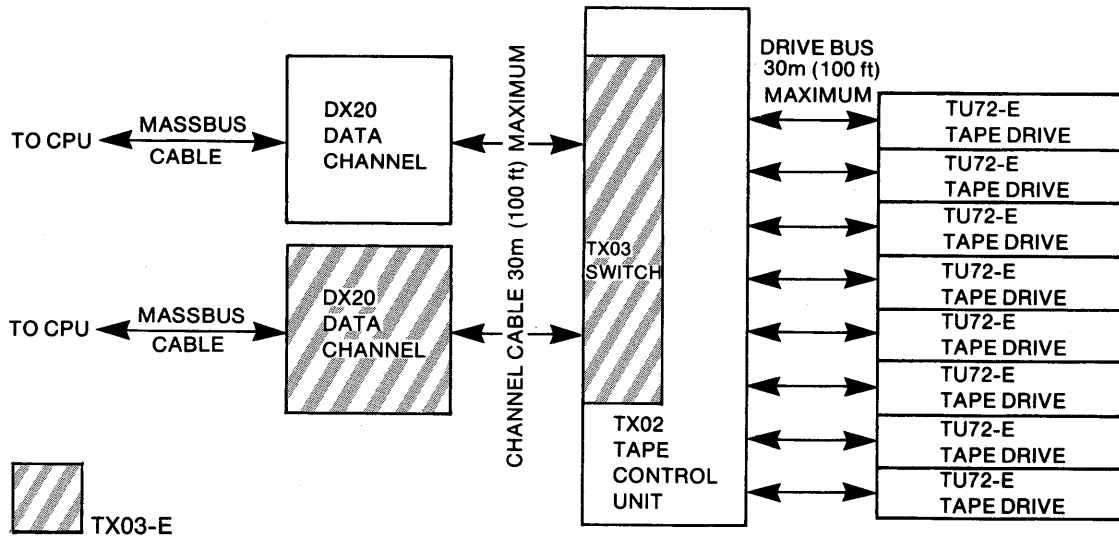
CABLE	DESCRIPTION	MAXIMUM LENGTH
BC06S	MASSBUS CABLE	39m (130 ft)
BS10B	DRIVE BUS	30m (100 ft)
BC10W	TX05 COMMUNICATOR CABLE	25m (85 ft)
BC10X	EMERGENCY POWER-OFF CABLE	30m (100 ft)
BC10Y	BUS OR TAG CABLE	30m (100 ft)
BC10Z	CHANNEL CABLE	30m (100 ft)

**NOTES:**

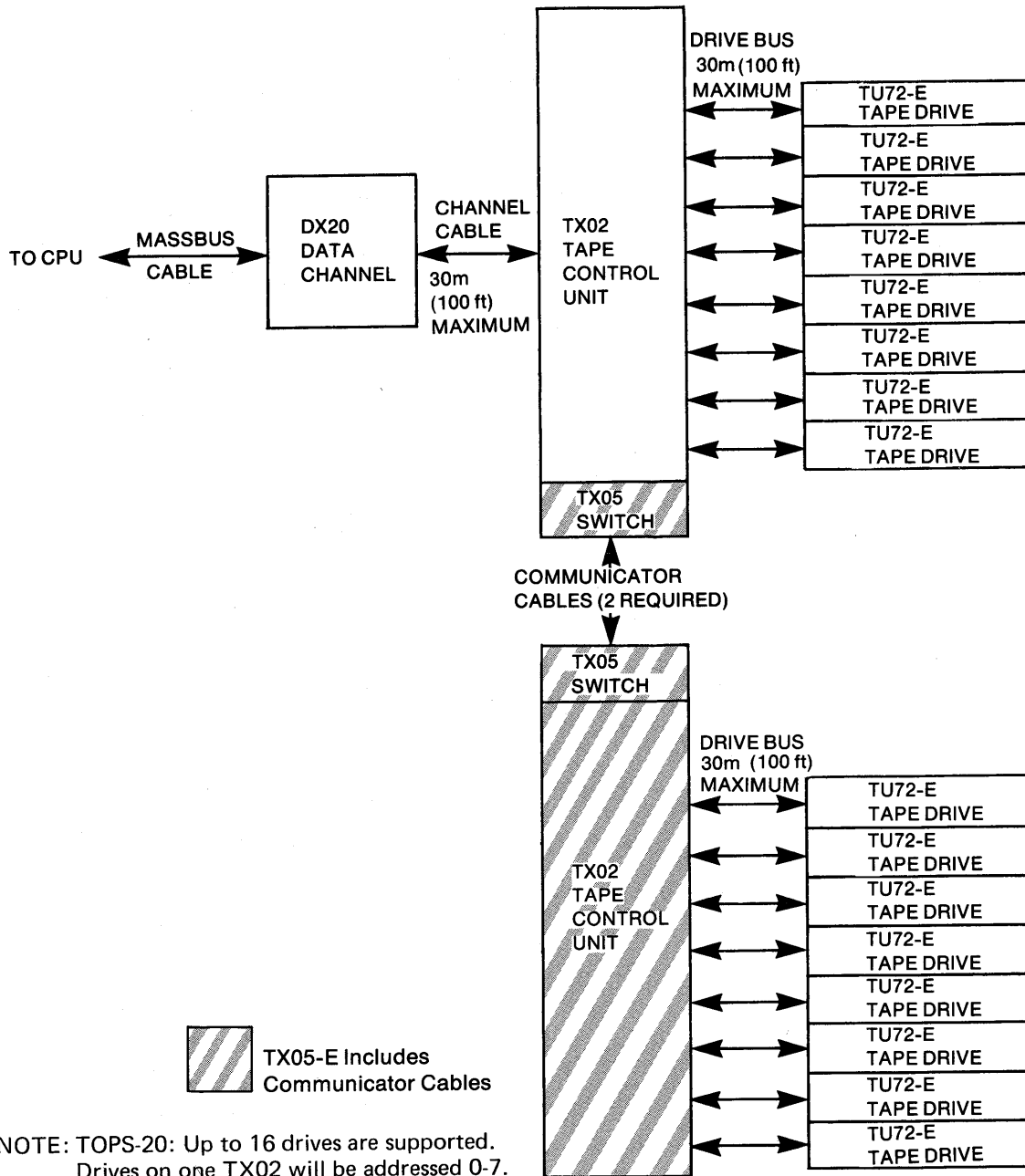
- (1) Cables supplied are 25 feet long. Other lengths are available at an additional charge.
- (2) Maximum combined length of drive bus and communicator cable is 36m (120 ft).
- (3) Maximum combined length of channel bus, and bus or tag cable is 30m (100 ft).



**Figure 5**  
Single-Channel Configuration  
TX02-E Plus Tape Drives

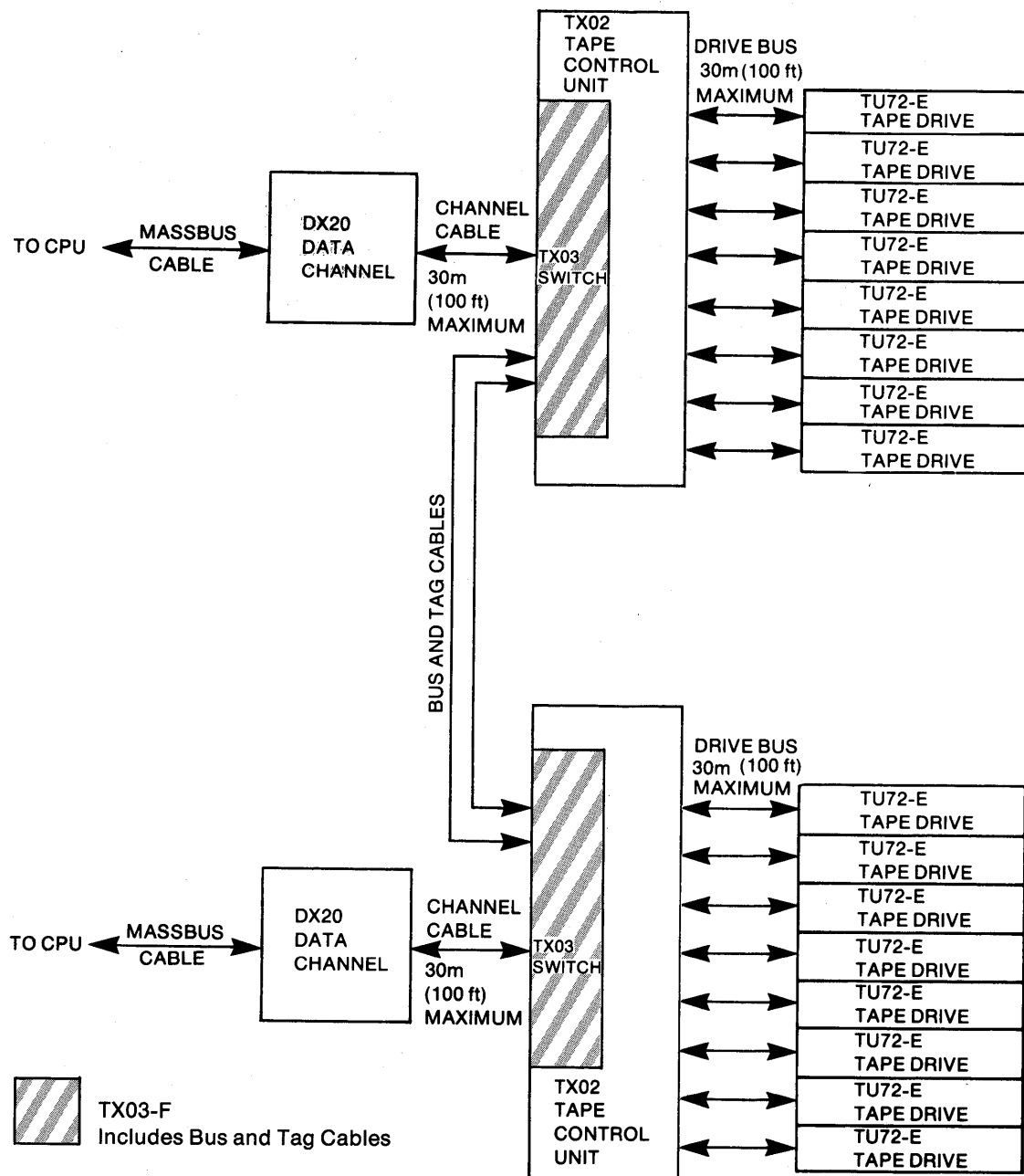


**Figure 6**  
Dual-Channel Configuration  
TX02-E Plus TX03-E and Tape Drives



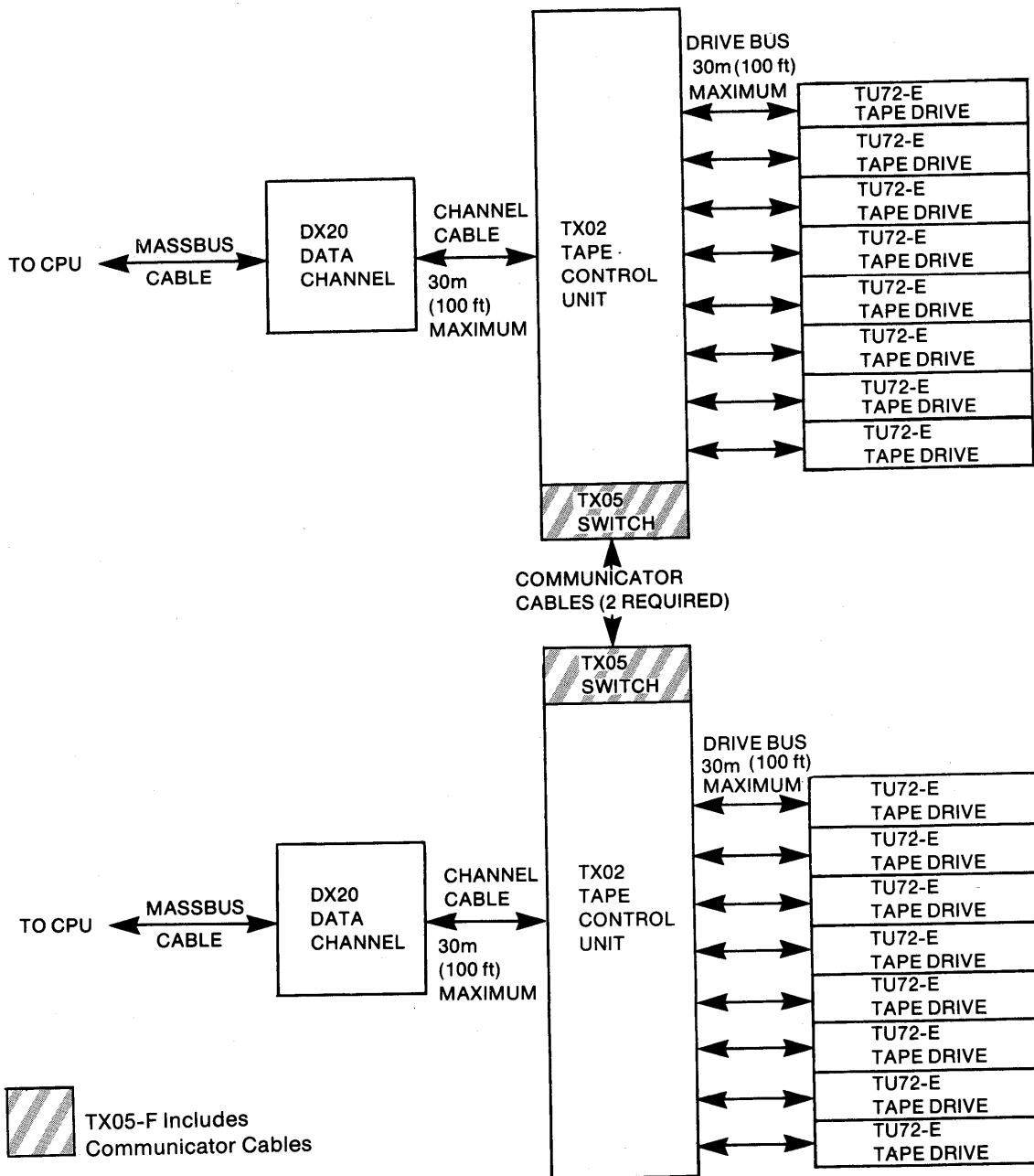
NOTE: TOPS-20: Up to 16 drives are supported.  
 Drives on one TX02 will be addressed 0-7.  
 Drives on other TX02 will be addressed 10-17.  
 TOPS-10: Not supported.

**Figure 7**  
**Single-Channel Extended Configuration**  
**TX02-E plus TX05-E and Tape Drives**



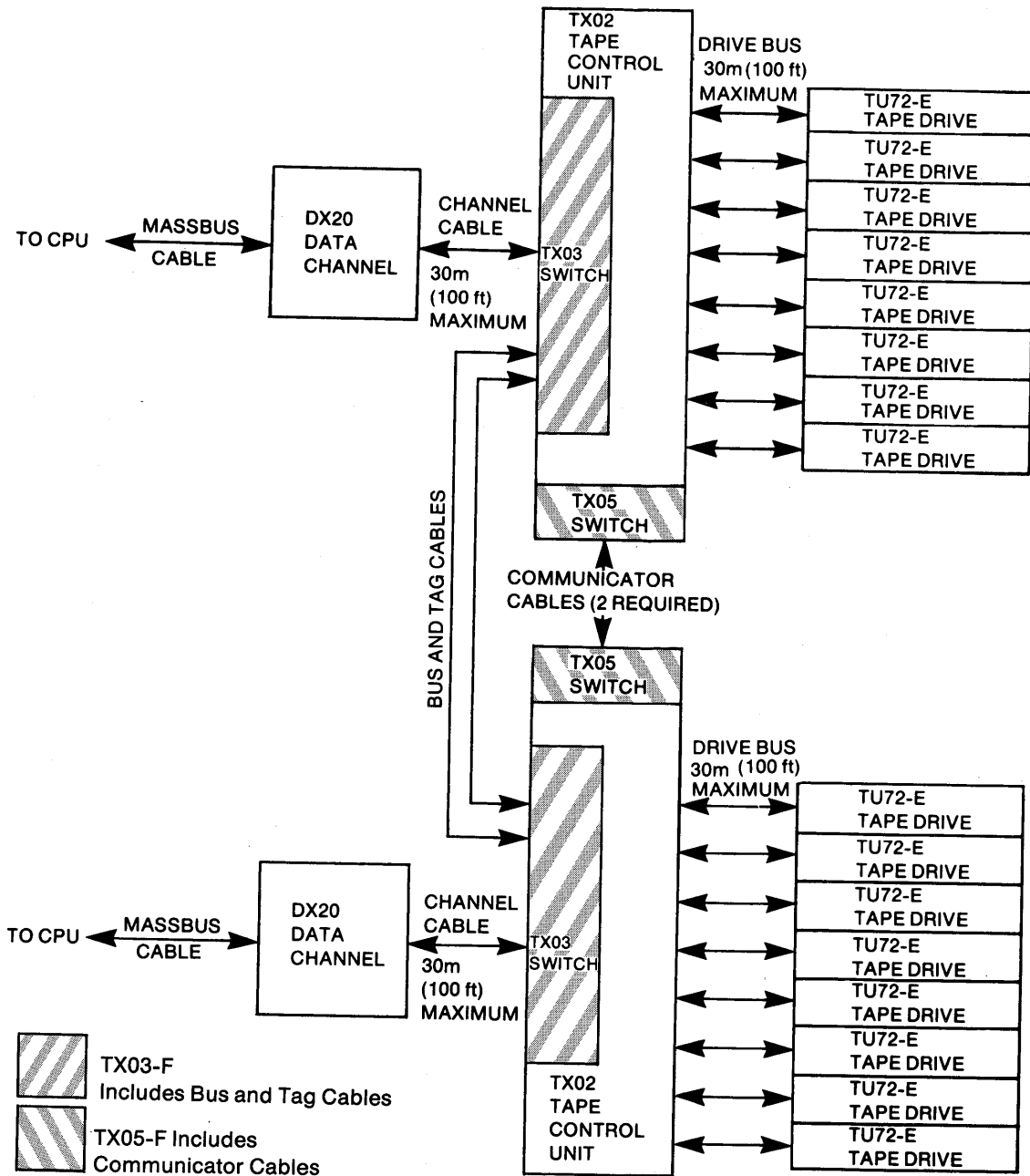
NOTE: TOPS-20: Up to 16 drives are supported.  
 Drives on one TX02 will be addressed 0-7.  
 Drives on other TX02 will be addressed 20-27.  
 TOPS-10: A maximum of 8 drives are supported.  
 They may be divided between the two controllers. Drives will be addressed as 0-7. A special patch is required. See your Home Office Software Support (HOSS).

**Figure 8**  
**Dual-Channel Two-Control Unit Configuration**  
**Two TX02-Es Plus Optional TX03-F and Tape Drives**



NOTE: TOPS-20: Up to 16 drives are supported.  
 Drives on one TX02 will be addressed 0-7.  
 Drives on other TX02 will be addressed 10-17.  
 TOPS-10: A maximum of 8 drives are supported  
 addressed 0-7 and all must be configured on  
 one TX02 controller.

**Figure 9**  
**Two-Channel/Dual-Control Unit Configuration**  
**Two TX02-Es Plus TX05-F and Tape Drives**



NOTE: TOPS-20: Up to 16 drives are supported. Drives on one TX02 will be addressed 0-7. Other TX02s will be addressed 10-17 (by TX05 path) or 20-27 (by TX03 path).  
 TOPS-10: A maximum of 8 drives are supported. They will be addressed as 0-7. For purposes of addressing the drives via the TX03 path the drives may be divided between the 2 controllers. However, a special patch is required. See your Home Office Software Support (HOSS). For purposes of addressing the drives via the TX05 all drives configured must be on one TX02 controller.

**Figure 10**  
**Dual-Channel/Dual-Control Unit Configuration**  
**Two TX02-Es Plus TX03-F Plus TX05-F and Tape Drives**

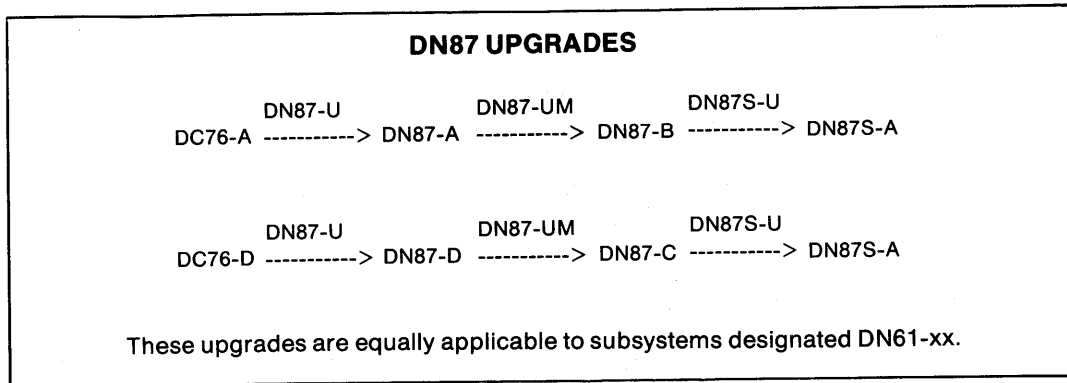
## MISCELLANEOUS OPTIONS

- DT03-DT      1 × 2 I/O bus switch - no cabinet or power control  
*PREREQUISITE:* 15-3/4 inch Mounting Space. If mounting space is not available, cabinet must be ordered.
- DT05-DT      1 × 2 memory bus switch - no cabinet or power control  
*PREREQUISITE:* 10-1/2 inch Mounting Space. If mounting space is not available cabinet must be ordered.
- TX03-A        Two channel switch for TX01.  
*PREREQUISITE:* TU70-C or TU72-C
- TX05-A        2 × 16 tape switch for the TX01.  
*PREREQUISITE:* TU70-C or TU72-C

**NOTE:** These options are made available for existing systems that may require the continued availability of these items. In most cases it is desirable to sell newer and mainstream products which would be found in the appropriate system sections of this product summary.

## DECsystem-1090 ONLY

### FRONT END COMMUNICATION UPGRADE OPTIONS



- DN87-U        Upgrade from DC76-A or D to DN87-A or D.
- DN87-UM      Upgrade from DN87-A to B and DN87-D to C.
- DN87S-U      Upgrade from DN87-B or C to DN87S.

## SYNCHRONOUS LINE OPTIONS FOR DN87

- DN81-EE  
DN81-EF      Synchronous expansion cabinet which includes one DN81-H synchronous line controller for up to 10K bits per second with EIA RS-232-C modem interface.  
*PREREQUISITE:* DN61/62/87
- DN81-H      Synchronous expansion line controller, for speeds up to 10K bits per second with EIA RS-232-C modem interface and includes a 25 foot cable.
- DN81-J      Synchronous expansion line controller, for speeds up to 40.8K bits per second with 303-type current modem interface and includes a 25 foot cable.
- DN83-A      Null Modem for use with the DN81-H for speeds of: 2.0, 2.4, 4.8, 9.6, and 19.2Kb.  
*PREREQUISITE:* DN81-H.

## ASYNCHRONOUS LINE OPTIONS FOR DN87

- DN81-EA  
DN81-EB      Asynchronous expansion cabinet including one DN81-EC, 16-line asynchronous expansion group, which also requires two DN81-Fx, 8-line terminator groups to activate the lines.
- DN81-EC  
DN81-ED      Asynchronous 16-line expansion group that requires two DN81-Fx 8-line terminator groups to activate the lines.  
*PREREQUISITE:* DN81-EA/B, (2) DN81-F
- DN81-FA      8-line terminators with 20mA current loop local interfaces which includes an H322 distribution panel.  
*PREREQUISITE:* DN81-EC/D
- DN81-FB      8-line terminators with EIA local interfaces which includes a 25 foot cable plus H312 null modems.  
*PREREQUISITE:* DN81-EC/D
- DN81-FC      8-line terminators with EIA full modem control interfaces which include 8 25-foot cables.  
*PREREQUISITE:* DN81-EC/D
- DN81-FD      8-line terminators with integral Auto-Answer modems.  
*PREREQUISITE:* DN81-EC/D
- DN81-FF      Controller for 2 Bell 801-type Automatic Calling Units (ACU) which include one DN81-FG.
- DN81-FG      Expansion for additional Bell 801-type Automatic Calling Unit (ACU).
- H312-A      Null modem for use with DN81-FC.  
*PREREQUISITE:* DN81-FB
- H322      Distribution Panel which distributes signals from two DN81-FAs to nine 10-screw terminal strips.

**NOTE:** These options are made available for existing systems that may require the continued availability of these items. In most cases it is desirable to sell newer and mainstream products which are found in the appropriate system sections of this product summary.

## SYSTEMS & OPTIONS INDEX

Option No.	Page	Option No.	Page	Option No.	Page	Option No.	Page
1077-UA	11	BC10R-20	74	DC20-EC(ED)	48	DN87S-U	83
1090-PC(PD)	5	BC10R-30	74	DF01-A	60	DNCXX-AA(AB)	10,26,49
1090-VC(VD)	11	BC10R-40	74	DIB20	24,48		
1090L-PC(PD)	5	BC10S-20	74	DN20-BA	9,25,38,49	DNHXX-AA(AB)	37
1090S-UE(UF)	6	BC10S-50	74	DN20-BB	10,25,38,49	DNLXX-BA(BB)	10,26,49
1090S-UG(UG)	6	BC10S-70	74	DN20-CA(CB)	48		
1091-SC(SD)	20	BC10S-A0	74	DN20-CC(CD)	9,25	DNLXX-CA(CB)	10,26,49
1091L-SC(SD)	20	BC10W-25	72	DN20-DA(DB)	10,25,49		
2020-JE(JF)	36	BC10W-50	72	DN20-MA(MB)	49	DNSXX-AA	10,26,49
2020-JG(JH)	36	BC10W-75	72	DN20-MU	49	DNSXX-AB	10,26,49
2020-KE(KF)	36	BC10W-AO	72	DN200-AA(AB)	10,26	DT03-DT	83
2020-KG(KH)	36	BC10X-25	72	DN200-BA(BB)	49	DT05-DT	83
2020-PE(PF)	34	BC10X-50	72	DN21-BA	10,25,49	DZ11-AA	38
2020-PG(PH)	34	BC10X-75	72	DN21-BB	49	DZ11-BA	38
2020-SE(SF)	34	BC10X-AO	72	DN21-DA(DB)	10,25,49	H312-A	84
2020-SG(SH)	34	BC10Y-25	72	DN21-HA	49	H322	84
2020L-PE(PF)	35	BC10Y-50	72	DN22-AA(AB)	38	KL10-FA(FB)	6
2020L-PG(PH)	35	BC10Y-75	72	DN25-AA	10,25	KL10-PM(PB)	11
2020L-SE(SF)	35	BC10Y-AO	72	DN25-AB	10,25	KL10-PV	11
2020L-SG(SH)	35	BC10Z-25	72	DN25-BA	10,25	LA120-DA	60
2040-SC(SD)	44	BC10Z-50	72	DN25-DA(DB)	10,25	LA12X-AL	60
2040L-SC(SD)	44	BC10Z-75	72	DN25-EC(ED)	10,25	LA38-AA	60
2060-PE(PF)	44	BC11S-25	70	DN81-EA(EB)	84	LA380BA	60
2060-UA	50	BS10B-25	72	DN81-EC(ED)	84	LAX34-CL	60
2060-UB	50	BS10B-35	72	DN81-EE(EF)	84	LP07-YA	8,23,47
2060-UC	50	BS10B-50	72	DN81-FA	84	LP07-YB	8,23,47
2060-UD	50	CD20-AA(AB)	24,37,48	DN81-FB	84	LP07-YC	8,23,47
2060L-PE(PF)	44	CD20-CA(CB)	24,37,48	DN81-FC	84	LP07-YD	8,23,47
70-1426-A0	72		48	DN81-FD	84	LP07-YF	8,23,47
BC03M-25	71	CR10-FA(FB)	9	DN81-FF	84	LP07-YH	8,23,47
BC03M-A0	71	CR10-HA(HB)	9	DN81-FG	84	LP07-YJ	8,24,47
BC03M-B5	71	DC20-AA	24,48	DN81-H	84	LP07-YK	9,24,47
BC03M-E0	71	DC20-CC	48	DN91-J	84	LP07-YL	9,24,47
BC03M-L0	71	DC20-CD	24	DN83-A	84	LP07-YM	9,24,48
BC05D-10	70	DC20-DA	24,48	DN87-U	83	LP100-BA(BB)	8
BC05D-25	70	DC20-EA(EB)	24	DN87-UM	83	LP100-DA(DB)	8

Option No.	Page	Option No.	Page	Option No.	Page	Option No.	Page
LP100-DC(DD).....	8	RP20-CB.....	7,22,46	QH115.....	65	QT038.....	66
LP100-EA(EB).....	8	RTP20-EA(EB).....	22	QH300.....	65	QT040.....	66
LP100-EC(ED).....	8	RTP20-EC(ED).....	22	QH302.....	64	QT042.....	64
LP100-FA(FB).....	8	RTP20-EE(EF).....	7	QH500.....	65	QT046.....	67
LP100-FC(FD).....	8	RTP20-EH(EJ).....	7	QH502.....	65	QT047.....	66
LP100-HA(HB).....	8	RTP20-FA(FB).....	45	QH503.....	65	QT052.....	64
LP100-HC(HD).....	8	RTP20-FC(FD).....	46	QH509.....	66	QT054.....	66
LP20-AA(AB) ...	23,37,47	RTP20-FE(FF).....	45	QH512.....	66	QT062.....	64
LP20-AC(AD) ...	23,37,47	TAU77-EC(ED).....	36	QH603.....	64	QT099.....	65
LP20-BA(BB) ...	23,37,47	TU72-EC(ED).....	7,22,46	QH666.....	66	QT115.....	65
LP20-BC(BD) ...	23,37,47	TU77-AF(AJ).....	7,22,46	QH682.....	64	QT850.....	67
LP20-CA(CB) ...	23,37,47	TU77-CB(CD)D ..	7,22,46	QH850.....	67	QTD01.....	64
LP20-CC(CD) ...	23,37,47	TX02-EC(ED).....	7,22	QHK12.....	66	QTD20.....	64
LP20-DA(DB) ...	23,37,47	TX02-EE(EF).....	46	QHK14.....	66	ZT001.....	64
LP20-DC(DD) ...	23,37,47	TX02-EH(EJ).....	22	QHK20.....	66		
LP200-BA(BB).....	23,47	TX03-A.....	83	ZH006.....	67		
M9301-WA.....	6	TX03-EC(ED).....	7	ZH007.....	67		
M9301-WB.....	6	TX03-EE(EF).....	46	ZH008.....	67		
MF20-E.....	20,44	TX03-EH(EJ).....	22	ZH009.....	67		
MF20-LA(LB).....	20,44	TX03-FB.....	7,22,46	ZH010.....	67		
MF20-LC(LD).....	20,44	TX05-A.....	83	QT001.....	65		
MF20-LH(LJ).....	44	TX05-EC(ED).....	8,23,46	QT002.....	65		
MF20-LK(LL).....	20	TX05-FB.....	8,23,46	QT004.....	66		
MF20-LM(LN).....	20	VT100-AA(AB).....	60	QT007.....	65		
MH10-E.....	6	VT1XX-AA.....	60	QT008.....	65		
MH10-HA(HB).....	6	VT1XX-AB.....	60	QT009.....	65		
MH10-LA(LB).....	6			QT012.....	65		
MS10-BA.....	36			QT014.....	65		
		<b>SYSTEM SOFTWARE</b>					
PC10-CL(CM).....	9	<b>Option No.</b>	<b>Page</b>	QT016.....	65		
PC20-BL(BM).....	24	QH020.....	65	QT018.....	66		
PC20-CL(CM).....	48	QH045.....	65	QT021.....	66		
RH20.....	6,21,45	QH060.....	65	QT024.....	66		
RP06-AA(AB) ...	21,36,45	QH071.....	65	QT025.....	65		
RP06-BA(BB).....	6,20,45	QH072.....	66	QT027.....	65		
RP06-C.....	6,20,45	QH074.....	66	QT028.....	66		
RP20-AC(AD).....	7,21	QH076.....	66	QT029.....	66		
RP20-AH(AJ).....	45	QH099.....	65	QT030.....	66		
RP20-CA.....	7,22,46	QH101.....	65	QT037.....	65		

