

MG-20

# FIELD MAINTENANCE PRINT SET TABLE OF CONTENTS

UNIT VARIATIONS  
COVERED BY THIS  
PRINT SET

- MG20-LA
- MG20-LB
- MG20-LC
- MG20-LD

MG20-L  
FIELD MAINTENANCE  
PRINT SET

DIGITAL EQUIPMENT  
CORPORATION

PRINT SET PART NO.  
MP01904-01

"THE MATERIAL HEREIN IS FOR INFORMATION PURPOSES ONLY AND IS  
SUBJECT TO CHANGE WITHOUT NOTICE. DIGITAL EQUIPMENT CORPORATION  
ASSUMES NO RESPONSIBILITY FOR ANY ERRORS WHICH MAY APPEAR HEREIN."

THIS DRAWING AND SPECIFICATIONS  
HEREIN ARE THE PROPERTY OF  
DIGITAL EQUIPMENT CORPORATION AND  
SHALL NOT BE REPRODUCED OR COPIED  
OR USED IN WHOLE OR IN PART AS  
THE BASIS FOR THE MANUFACTURE OR  
SALE OF ITEMS WITHOUT WRITTEN  
PERMISSION. COPYRIGHT © 1984,  
DIGITAL EQUIPMENT CORPORATION.

REVISIONS	
CHK	CHANGE NO. / REV
	RELEASED A

digital	DRW: <i>J. J. J.</i>	DATE: 22-JUN-84	ENG: <i>W. J. J.</i>	DATE: 25-JUN-84	TITLE: MOS MEMORY MG20
	CHK: <i>W. J. J.</i>	DATE: 22-JUN-84	BOARD LOCATION: N/A	SHEET: 1 OF 3	
DSK: MG20TC.T2PL4.571		22-JUN-84 14:44	NEXT HIGHER ASSEMBLY: NONE	SIZE CODE: D TC	NUMBER: MG20-L-1
FIRST USED ON OPTION/MODEL: MG20				REV.:	A

REV. A  
NUMBER MG20-L-1  
TC  
D  
B  
A

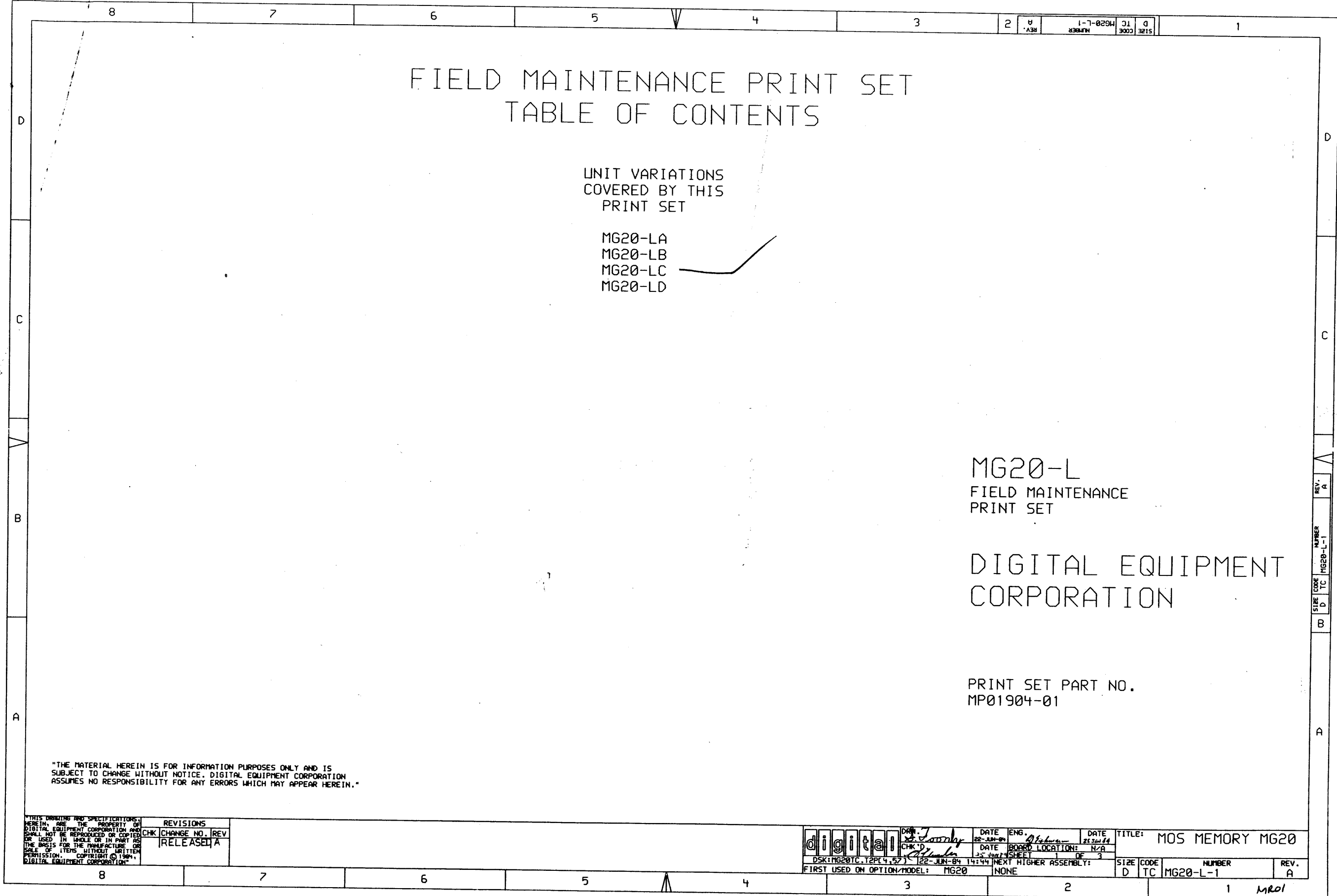

DOCUMENT NUMBER	REV	DESCRIPTION
D-TC-MG20-L-1	A	TABLE OF CONTENTS
D-MU-MG20-0-2	A	MG20 MODULE UTILIZATION LIST
D-MU-MG20-L-CPMU	A	MODULE UTILIZATION

MODULE (C.S.) MOS MEMORY

D-DD-5412855-0	*	XBUS TERMINATOR SHEET 1
D-UA-5412855-0-0	A	XBUS TERMINATOR SHEET 1
D-CS-5412855-0-1	*	XBUS TERMINATOR BOARD

D-DD-5412851-0	B	ADDRESS TIMER SHEET 1
D-UA-5412851-0-0	D	ADDRESS TIMER SHEET 1
D-CS-5412851-0-OSC1	A	SELECT LOGIC
D-CS-5412851-0-OSC2	B	POWER SUPPLY

D-DD-M8572-0	A	CABLE BOARD SHEET 1
D-UA-M8572-0-0	B	CABLE BOARD SHEET 1
D-CS-M8572-0-XCD1	*	CLK SEL LOGIC
D-CS-M8572-0-XCD2	A	XBUS CABLE
D-CS-M8572-0-XCD3	*	POWER AND GND

D-DD-M8574-0	B	WRITE PATH SHEET 1
E-UA-M8574-0-0	B	WRITE PATH SHEET 1
D-CS-M8574-0-WRP0	A	DATA 00-15
D-CS-M8574-0-WRP1	*	DATA 16-PAR
D-CS-M8574-0-WRP2	*	MIX AND LATCH A
D-CS-M8574-0-WRP3	*	MIX AND LATCH B
D-CS-M8574-0-WRP4	*	MIX AND LATCH C
D-CS-M8574-0-WRP5	*	DATA BUFFER
D-CS-M8574-0-WRP6	*	ECC GENERATOR
D-CS-M8574-0-WRP7	*	ECC DIAG REG
D-CS-M8574-0-WRP8	*	SPARE BIT RAM
D-CS-M8574-0-WRP9	*	SPARE BIT MIXER
D-CS-M8574-0-WRPA	*	POWER. GND. CAPS.
D-CS-M8574-0-WRPB	*	POWER. GND. CAPS.
D-CS-M8574-0-RES	*	TERMINATORS

DOCUMENT NUMBER	REV	DESCRIPTION
D-DD-M8575-0	*	SYNDROME SHEET 1
E-UA-M8575-0-0	A	SYNDROME SHEET 1
D-CS-M8575-0-SYN0	*	BIT SUB DECODER
D-CS-M8575-0-SYN1	*	BIT SUB DATA
D-CS-M8575-0-SYN2	*	BIT SUB,ECC BITS
D-CS-M8575-0-SYN3	*	GENERATOR
D-CS-M8575-0-SYN4	*	CALCULATOR
D-CS-M8575-0-SYN5	*	CORRECTION DECODE
D-CS-M8575-0-SYN6	*	DATA CORRECTION
D-CS-M8575-0-SYN7	*	PORT ADDRESS
D-CS-M8575-0-SYN8	*	DIAG SELECTION
D-CS-M8575-0-SYN9	*	DIAG MIXER
D-CS-M8575-0-SYNA	*	POWER CONTROL
D-CS-M8575-0-SYNB	*	POWER. GND. CAPS.
D-CS-M8575-0-SYNC	*	POWER. GND. CAPS.
D-CS-M8575-0-RES	*	TERMINATORS

D-DD-M8576-0	A	MOS CONTROL SHEET 1
E-UA-M8576-0-0	B	MOS CONTROL SHEET 1
D-CS-M8576-0-CTL0	*	SBUS DRVR & RECVR
D-CS-M8576-0-CTL1	A	START LOGIC
D-CS-M8576-0-CTL2	A	CYCLE CONTROL
D-CS-M8576-0-CTL3	A	WRITE DATA MOVER
D-CS-M8576-0-CTL4	A	ERR REG & ACKN
D-CS-M8576-0-CTL5	*	READ DATA MOVER
D-CS-M8576-0-CTL6	*	DATA VALID
D-CS-M8576-0-CTL7	*	DIAGNOSTIC MOVER
D-CS-M8576-0-CTL8	A	DIAGNOSTIC CNTRL
D-CS-M8576-0-CTL9	*	SM PROM CONTROL
D-CS-M8576-0-CTLA	*	RAS & SEL DRVR
D-CS-M8576-0-CTLB	*	POWER. GND. CAPS.
D-CS-M8576-0-CTLC	*	POWER. GND. CAPS.
D-CS-M8576-0-RES	A	TERMINATORS

D-DD-M8577-0	B	ADDRESS AND TIME SHEET 1
E-UA-M8577-0-0	C	ADDRESS AND TIME SHEET 1
D-CS-M8577-0-ADT0	*	PORT ADR INTER
D-CS-M8577-0-ADT1	*	PORT ADR REG
D-CS-M8577-0-ADT2	*	PORT ADR MIXERS
D-CS-M8577-0-ADT3	*	REFRESH CYCLE
D-CS-M8577-0-ADT4	A	TIMING RAM
D-CS-M8577-0-ADT5	A	ARRAY TIME DRVRS
D-CS-M8577-0-ADT6	A	PHS COM CLOCK
D-CS-M8577-0-ADT7	*	ERR HANDLE LOGIC
D-CS-M8577-0-ADT8	*	DATA BUFFER
D-CS-M8577-0-ADT9	A	DIAGNOSTIC LOGIC
D-CS-M8577-0-ADTA	*	POWER. GND. CAPS.
D-CS-M8577-0-ADTB	*	POWER. GND. CAPS.
D-CS-M8577-0-RES	A	TERMINATORS

THIS DRAWING AND SPECIFICATIONS ARE THE PROPERTY OF DIGITAL EQUIPMENT CORPORATION AND SHALL NOT BE REPRODUCED OR COPIED OR USED IN WHOLE OR IN PART AS THE BASIS FOR THE MANUFACTURE OR SALE OF ITEMS WITHOUT WRITTEN PERMISSION. COPYRIGHT © 1984, DIGITAL EQUIPMENT CORPORATION.

REVISIONS	
CHK	CHANGE NO. REV.

	DRN: <i>J. Lashby</i> CHK'D: <i>J. Lashby</i>	DATE: 22-JUN-84 DATE: 22-JUN-84	ENG: <i>J. Lashby</i> BOARD LOCATION: N/A	DATE: 22-JUN-84 SHEET: 2 OF 3	TITLE: MOS MEMORY MG20
	DSK:MG20TC.T2P(4,57)	22-JUN-84 14:44	NEXT HIGHER ASSEMBLY: NONE	SIZE CODE: D	NUMBER: MG20-L-1

DOCUMENT NUMBER REV DESCRIPTION

D-DD-M8570-0	A	MOS STORAGE SHEET 1
F-LIA-M8570-0-0	A	MOS STORAGE SHEET 2
D-CS-M8570-0-SM00	A	ARRAY BIT[T+00]
D-CS-M8570-0-SM01	A	ARRAY BIT[T+01]
D-CS-M8570-0-SM02	A	ARRAY BIT[T+02]
D-CS-M8570-0-SM03	A	ARRAY BIT[T+03]
D-CS-M8570-0-SM04	A	ARRAY BIT[T+04]
D-CS-M8570-0-SM05	A	ARRAY BIT[T+05]
D-CS-M8570-0-SM06	A	ARRAY BIT[T+06]
D-CS-M8570-0-SM07	A	ARRAY BIT[T+07]
D-CS-M8570-0-SM08	A	ARRAY BIT[T+08]
D-CS-M8570-0-SM09	A	ARRAY BIT[T+09]
D-CS-M8570-0-SM10	A	ARRAY BIT[T+10]
D-CS-M8570-0-SM11	A	WR PULSE LOGIC
D-CS-M8570-0-SM12	A	ROW ADR STROBE
D-CS-M8570-0-SM13	A	COL ADR STROBE
D-CS-M8570-0-SM14	A	ADDRESS CONTROL
D-CS-M8570-0-SM15	A	SM TERMINATOR
D-CS-M8570-0-SM16	A	GNDS, SPARE TERMS
D-CS-M8570-0-SM17	A	5V PWR1/RAMS CAPS
D-CS-M8570-0-SM18	A	5V PWR2/CNTL CAPS
D-CS-M8570-0-SM19	A	-5.2V/-2.0V CAPS

D-DD-M8580-0	*	DUAL TRANSLATOR SHEET 1
D-LIA-M8580-0-0	A	DUAL TRANSLATOR SHEET 1
D-CS-M8580-0-DT01	*	DUAL TRANSLATOR
D-CS-M8580-0-DT02	*	DATA TRNCVR 0-5
D-CS-M8580-0-DT03	*	DATA TRNCVR 6-11
D-CS-M8580-0-DT04	*	DATA TRNCVR 12-17
D-CS-M8580-0-DT05	*	ADDRESS DRIVERS
D-CS-M8580-0-DT06	*	CTRL & REF VOLT
D-CS-M8580-0-DT07	*	MEM DATA DRVRS
D-CS-M8580-0-DT08	*	POWER. GND. CAPS.
D-CS-M8580-0-RES	*	TERMINATORS

D-DD-M8581-0	*	XBUS TRANSLATOR SHEET 1
D-LIA-M8581-0-0	A	XBUS TRANSLATOR SHEET 1
D-CS-M8581-0-DX01	*	XBUS TRANSLATOR
D-CS-M8581-0-DX02	*	DATA TRNCVR 0-5
D-CS-M8581-0-DX03	*	DATA TRNCVR 6-11
D-CS-M8581-0-DX04	*	DATA TRNCVR 12-17
D-CS-M8581-0-DX05	*	ADDRESS DRIVERS
D-CS-M8581-0-DX06	*	CTRL & REF VOLT
D-CS-M8581-0-DX07	*	POWER. GND. CAPS.
D-CS-M8581-0-RES	*	TERMINATORS

OPTION/ASSY MOS MEMORY

DOCUMENT NUMBER	REV	DESCRIPTION
D-IC-MG20-L-2	A	MG20-L CABLE DIAGRAM
D-BD-MG20-0-1	A	STORAGE ARRAY ORGANIZATION
D-BD-MG20-0-3	A	MG20M BLOCK DIAGRAM
D-BD-MG20-0-4	A	MG20 BLOCK DIAGRAM
D-TD-MG20-0-5	A	MG20 TIMING RAMS
E-TD-MG20-0-6	A	MG20 READ CYCLE TIMING DIAGRAM
E-TD-MG20-0-7	A	MG20 WRITE CYCLE TIMING DIAGRAM
D-FD-MF20-0-5	*	MF20 READ CYCLE FLOW CHART
D-FD-MF20-0-6	*	MF20 REFRESH CYCLE FLOW CHART
D-FD-MF20-0-7	*	MF20 WRITE CYCLE FLOW CHART
D-TD-MF20-0-8	*	DIAGNOSTIC CYCLE TIMING DIAGRAM
D-TD-MF20-0-9	*	MF20 READ/REFRESH CYCLE TIMING DIAGRAM
D-TD-MF20-0-12	*	REFRESH CYCLE TIMING DIAGRAM
D-BD-MF20-0-13	*	BATTERY BOX BLOCK DIAGRAM
D-IC-MF20-0-14	*	POWER SUPPLY CONNECTOR DIAGRAM
D-BD-MF20-0-16	*	MASTER OSCILLATOR BLOCK DIAGRAM
D-BS-MF20-0-18	*	MF20 FIXED VALUED RAM CONTENTS
D-BS-MF20-0-19	*	MF20 BACKPLANE XBUS CONNECTIONS
A-SP-MF20-0-SYNC	*	MF20 XBUS CLOCK SYNCHRONIZATION
A-SP-MF20-0-2	B	INSTALLATION PROCEDURE
E-LIA-MF20-0-0	D	MOS MEMORY
K-PL-MG20-L-DBP	A	MOS MEMORY (PL)
E-LIA-KW20-0-0	B	MASTER OSCILLATOR
A-PL-KW20-0-0	B	MASTER OSCILLATOR (PL)
E-AD-7015075-0-0	B	BATTERY BOX ASSY
A-PL-7015075-0-0	B	BATTERY BOX ASSY (PL)
E-AD-7016018-0-0	C	CARD CAGE ASSY
K-PL-7016018-0-0	A	CARD CAGE ASSY (PL)
E-AD-7014358-0-0	*	WIRED ASSY MF20
K-WL-MF20-0-WL	C	WIRE LIST (MF20)
K-PL-MG20-L-SH	A	SHIP LIST

NOTE: A REVISION DESIGNATED AS "\*" REPRESENTS THE INITIAL RELEASE REVISION OF A DOCUMENT IN THE CASE WHERE THE INITIAL RELEASE REVISION WAS "-", "\*", OR WAS LEFT BLANK.

THIS DRAWING AND SPECIFICATIONS ARE THE PROPERTY OF DIGITAL EQUIPMENT CORPORATION AND SHALL NOT BE REPRODUCED OR COPIED OR USED IN WHOLE OR IN PART AS THE BASIS FOR THE MANUFACTURE OR SALE OF ITEMS WITHOUT WRITTEN PERMISSION. COPYRIGHT © 1981, DIGITAL EQUIPMENT CORPORATION.

REVISIONS		
CHK	CHANGE NO.	REV



DRN: J. J. J.	DATE: 22-JUN-84	ENG: R. J. J.	DATE: 22-JUN-84	TITLE: MOS MEMORY MG20
CHK: J. J. J.	DATE: 22-JUN-84	BOARD LOCATION: N/A	SHEET: 3	OF: 3
DSK:MG20TC.T2PL4.57		122-JUN-84 14:44	NEXT HIGHER ASSEMBLY:	SIZE CODE: D TC
FIRST USED ON OPTION/MODEL: MG20		NONE	NUMBER: MG20-L-1	REV: A

THIS DRAWING AND SPECIFICATIONS, HEREIN, ARE THE PROPERTY OF BENTON ELECTRONIC CORPORATION AND SHALL NOT BE REPRODUCED OR COPIED IN WHOLE OR IN PART WITHOUT THE WRITTEN PERMISSION OF BENTON ELECTRONIC CORPORATION.

NOTES:

- 1A. GROUP 0 IS FIRST 1024K WORDS.
- 1B. GROUP 1 IS SECOND 1024K WORDS.
- 2. TWO GROUPS (MG20-E'S) REPRESENT THE MAXIMUM CONFIGURATION IN EACH MG20 BACKPLANE.

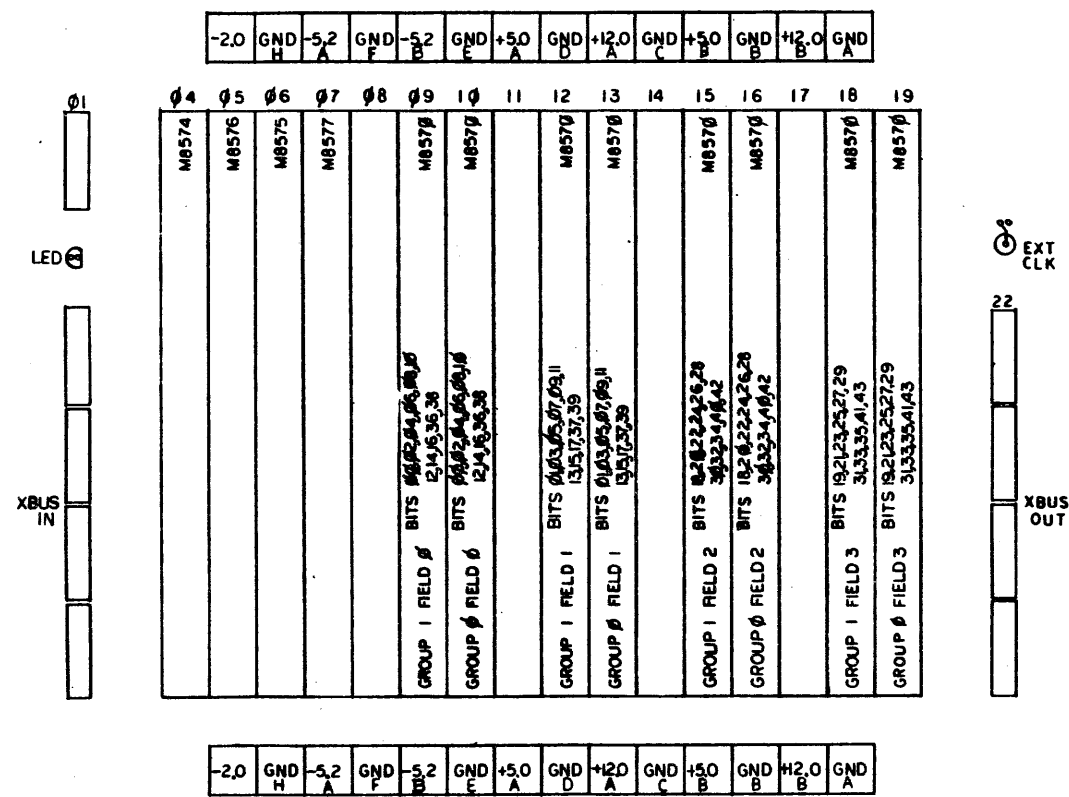

REVISIONS  
 CHANGE NO. 1  
 RELEASED A

DRN. <i>H. H. H.</i>	FIRST USED ON	MG 20-L <i>digital</i>		
CHK'D <i>P. J. J.</i>	TITLE	MG20 MODULE		
ENG. <i>P. J. J.</i>	UTILIZATION LIST			
PROD. ENG. <i>P. J. J.</i>	NEXT HIGHER ASSY.	SIZE	CODE	NUMBER
	B-DD-MG20-1	D	MU	MG20-0-2
	SCALE	NONE		REV. A
	SHEET	1	OF	1

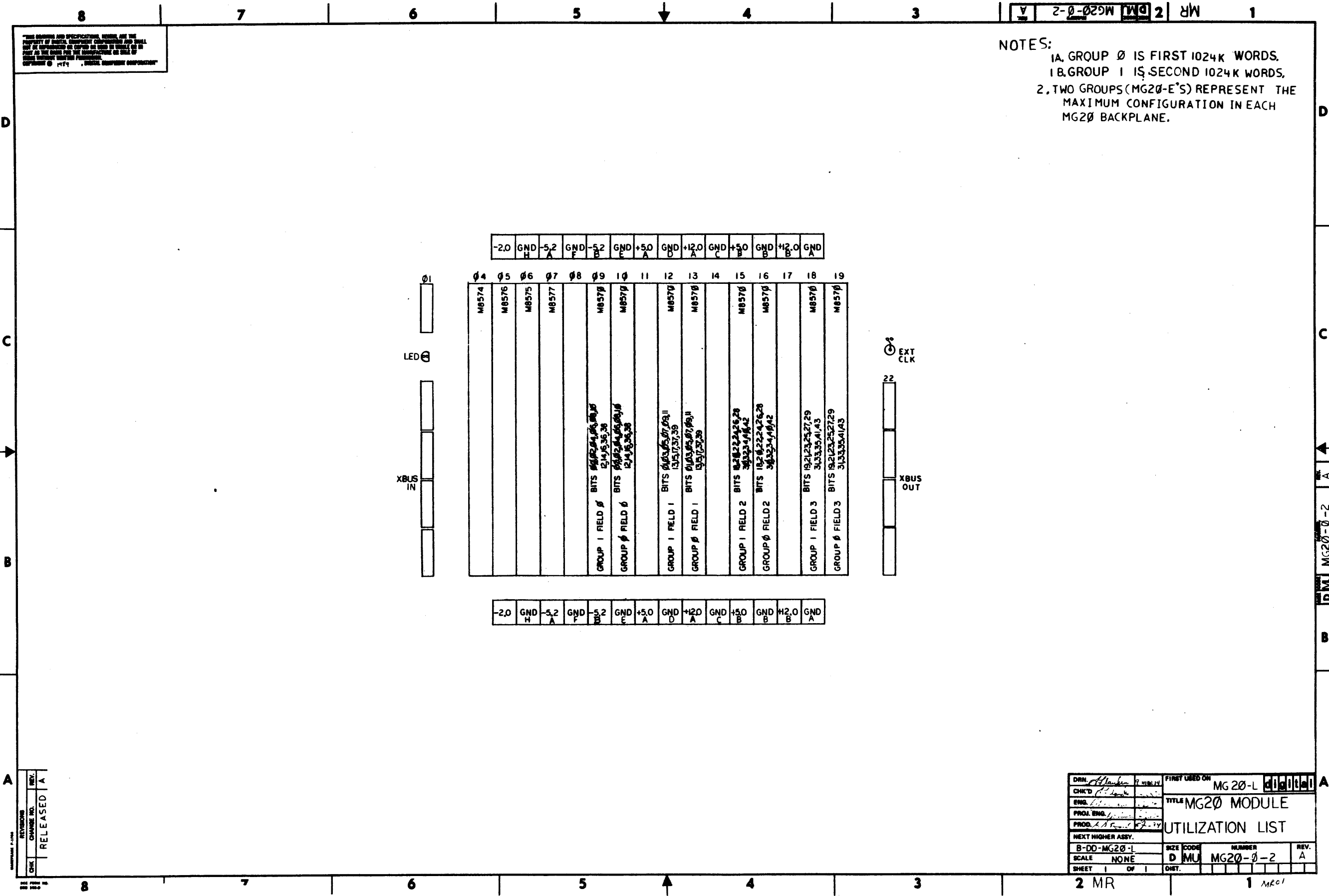

THIS DRAWING AND SPECIFICATIONS HEREIN ARE THE PROPERTY OF ORIGIN, GENERAL CORPORATION AND SHALL NOT BE REPRODUCED OR COPIED IN WHOLE OR IN PART WITHOUT THE WRITTEN PERMISSION OF ORIGIN. © 1977, GENERAL CORPORATION

DWG. NO. B-D-D-MG20-L-CPMU A

SEE NOTES 1, 2, 3

Slot	Cache No	Channel	Module / Variation
1			
2			
3			
4			
5			
6			
7			
8			
9			
10			
11			
12			
13			
14			
15			
16			
17			
19			
20			
22			
23			
24			
25			
26			
27			
28			
29			
30			
31			
32			
33			
34			
35			
36			
38			
39			
40			
41			
42			
43			
44			
45			
46			
47			
48			
49			
50			
51			
52			
53			
54			

VARIATION MODULE LOCATION CHART

SLOT	CACHE NO	CHANNEL	MODULE / VARIATION
9	M8540-YA		M8533
10	NONE		M8535
11	M8540 YD		M8536
12	M8540 YB		M8534
17	M8521		M8540-YH
18	NONE		NONE
19	M8521		M8540-YH
24	M8521		M8540-YH
25	M8521		M8540-YH
27	M8514		M8540-YE
28	M8515		M8540-YF
KL10 AA, AB REF		KL10 CA, CB REF	KL10 BA, BB, BC, BD REF

NOTES:

- SLOT 2 & 3 (SONS) DC20C CABLES FROM INTERNAL MEMORY, OR DMA20 OR EMPTY
- SLOT 1 (E AND C BUS) DC11A & DC20C CABLES FROM BTE
- XBUS CABLE BOARD (M8572)(ITEM#29) OF MG20-L P.L. IS PLUGGED INTO SLOT 2 OF KL10-PV/PW LOGIC ASSY FOR MG20-LA/LB.
- REPLACE (2) M8519'S IN SLOTS 7 AND 8 OF KL10-PV LOGIC ASSY WITH (2) M8580'S (ITEM#41) OF MG20 P.L..

SEE NOTE 4

REF. PIN SIDE  
\* SEE MODULE VARIATION TABLE

DATE: 11/18/77  
DRAWN: J. J. ...  
CHECKED: ...  
RELEASED: A

DESCRIPTION		DWG. PART NO.		ITEM NO.
UNLESS OTHERWISE SPECIFIED DIMENSIONS ARE IN INCHES				
ANNEAL	CLASS OF ACCURACY	NOMINAL DIMENSION RANGE INCHES		
MP 20'	(CHECK ONE)	0.000 - 0.250	0.250 - 0.500	0.500 - 1.000
SURFACE QUALITY	(CHECK ONE)	0.000 - 0.250	0.250 - 0.500	0.500 - 1.000
QUANTITY & VARIATION	(CHECK ONE)	0.000 - 0.250	0.250 - 0.500	0.500 - 1.000
THIRD ANGLE PROJECTION	DRW. BY: <i>J. J. ...</i>	DATE: <i>11/18/77</i>	FIRST USED ON: <i>MG20-L</i>	
REMOVE BURRS AND BREAK SHARP CORNERS	CHK'D: <i>J. J. ...</i>	ENG. <i>J. J. ...</i>	TITLE: <b>MODULE UTILIZATION (CPU)</b>	
DO NOT SCALE DIMS	PROJ. ENG. <i>J. J. ...</i>	PROD. <i>J. J. ...</i>	MATERIAL: <i>H</i>	
	NEXT HIGHER ASSY.		SCALE: <i>H</i>	
			FINISH: <i>H</i>	
			SIZE: <i>D</i>	
			CODE: <i>MJ</i>	
			NUMBER: <i>MG20-L-CPMU</i>	
			REV: <i>A</i>	
			SHEET: <i>1</i> OF <i>1</i>	
			DWT.:	

8 7 6 5 4 3 2 1

DRAWING NUMBER	PAGE	PART NO.	DESCRIPTION	REVISIONS
			FILE: ORIGINAL LAYOUT	
			ECO NUMBER	
			MODULE REVISION	A
D-UA-5412855-0-0	2		XBUS TERMINATOR	A
K-PL-5412855-0-0	1		PARTS LIST	A
D-CS-5412855-0-1	1		XBUS TERMINATOR BOARD	-
E-MD-5012854-0-0	2		DRILL & ETCH DRAWING	A
		5012854	ETCH CIRCUIT BOARD	B
K-PC-5412855-0-DBC	-		P.C. DESIGN DATA BASE	A

NOTES:

D  
C  
B  
A

D  
C  
B  
A

REV.  
NUMBER  
DD 15412855-0  
D  
B

THIS DRAWING AND SPECIFICATIONS, HEREIN, ARE THE PROPERTY OF DIGITAL EQUIPMENT CORPORATION AND SHALL NOT BE REPRODUCED OR COPIED OR USED IN WHOLE OR IN PART AS THE BASIS FOR THE MANUFACTURE OR SALE OF ITEMS WITHOUT WRITTEN PERMISSION.  
COPYRIGHT © 1976, DIGITAL EQUIPMENT CORPORATION

REVISIONS		
CHK	CHANGE NO.	REV

DRN <i>P. Lucian</i>	DATE <i>01-JAN-64</i>	ENG <i>John Hockenberry</i>	DATE <i>1/19/78</i>	TITLE: XBUS TERMINATOR
CHK'D <i>M. M...</i>	DATE <i>May 78</i>	BOARD LOCATION: <i>N2A</i>	SHEET <i>1</i> OF <i>1</i>	SIZE CODE NUMBER REV.
TERMD. TXT (4,662)	01-JAN-64 00:00	NEXT HIGHER ASSEMBLY:	SIZE CODE NUMBER REV.	
FIRST USED ON OPTION/MODEL: MF20	NCNE		D DD 5412855-0	



8 7 6 5 4 3 2 1

THIS DRAWING AND SPECIFICATIONS, HEREIN, AND THE PROPERTY OF DIGITAL EQUIPMENT CORPORATION AND SHALL NOT BE REPRODUCED OR COPIED OR USED IN WHOLE OR IN PART AS THE BASIS FOR THE MANUFACTURE OR SALE OF ITEMS WITHOUT WRITTEN PERMISSION.  
 COPYRIGHT © DIGITAL EQUIPMENT CORPORATION

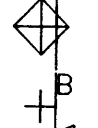
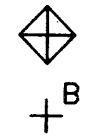
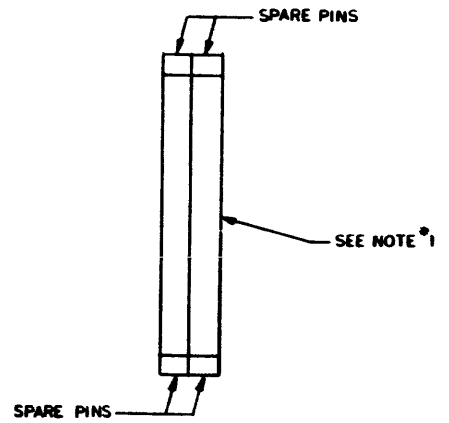
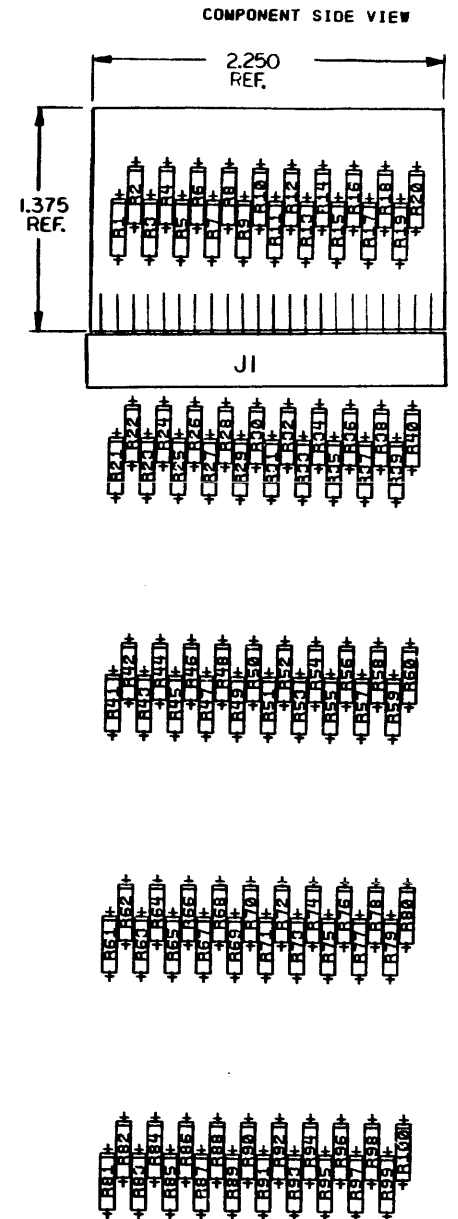

NOTES: 1. THE SPARE PINS SHOWN ARE ON THE CONNECTOR CARD ON BACKPLANE. THIS IS THE WRAP SIDE OF THE BACKPLANE.

CHANGE NO	REV

ETCH REV.	
P.L.C. DESIGN DATA BRD REV.	

SIGNATURES		DATE
DRN. <i>[Signature]</i>		10/26/78
CHK'D BY <i>[Signature]</i>		10/26/78
ENG. <i>[Signature]</i>		11/01/78
PROJ. ENG. <i>[Signature]</i>		11/02/78
PROD. <i>[Signature]</i>		11/02/78
SCALE 2:1		
SHT. 1 OF 2		
NEXT NUMBER PLSY. D-00-5412855-0		

digital	
TITLE	XBUS TERMINATOR
SIZE CODE	0 UA
NUMBER	5412855-0-0
REV	A

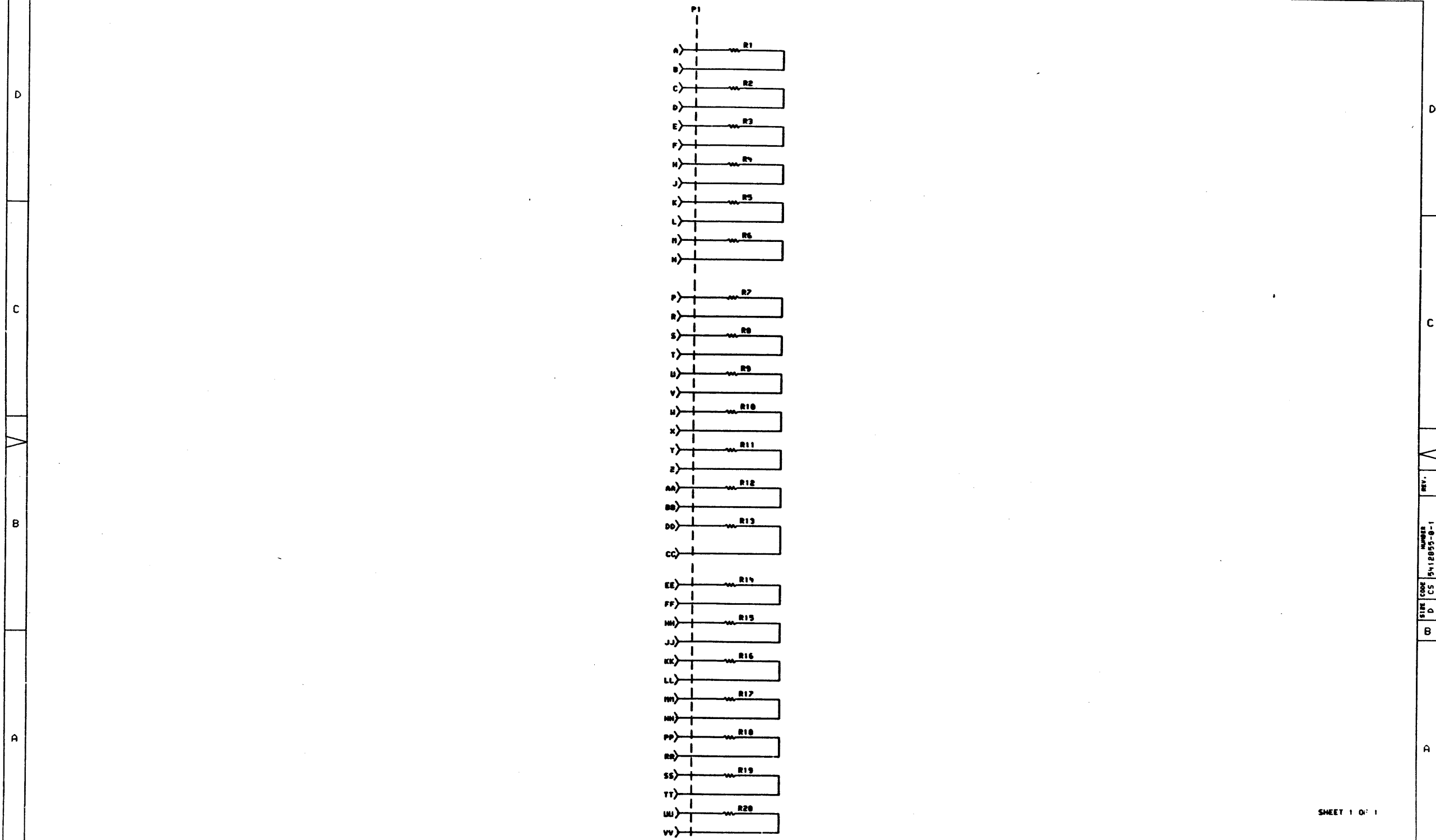

SHEET 1 OF 1

THIS DRAWING AND SPECIFICATIONS, HEREIN, ARE THE PROPERTY OF DIGITAL EQUIPMENT CORPORATION AND SHALL NOT BE REPRODUCED OR COPIED OR USED IN WHOLE OR IN PART AS THE BASIS FOR THE MANUFACTURE OR SALE OF ITEMS WITHOUT WRITTEN PERMISSION.  
 COPYRIGHT © 1970, DIGITAL EQUIPMENT CORPORATION

REVISIONS	
CHK	REV

	DRW. <i>P. Luciani</i>	DATE <i>12-10-70</i>	ENG. <i>P. Luciani</i>	DATE <i>1/20/70</i>	TITLE: XBUS TERMINATOR BOARD
	CHK'D <i>[Signature]</i>	DATE <i>1/20/70</i>	BOARD LOCATION: <i>[Blank]</i>	SHEET 1 OF 1	
FIRST USED ON OPTION/MODEL: MF20		NEXT HIGHER ASSEMBLY: D-DD-5412855-0		SIZE CODE: D CS	NUMBER: 5412855-0-1
				REV.:	

REV. NUMBER 5412855-0-1

8	7	6	5	4	3	2	1	MR
							0-1582145 3003 3215	
DRAWING NUMBER			PAGES	PART NO.	DESCRIPTION	REVISIONS		
					FILE: ORIGINAL LAYOUT			
					ECO NUMBER	1	2	
					MODULE REVISION	A	B	C
D-UA-5412851-0-0	5			MASTER OSCILLATOR	B	C	D	
K-PL-5412851-0-DBP	3			PARTS LIST	B	C	D	
D-CS-5412851-0-OSC1	1			SELECT LOGIC	-	-	A	
D-CS-5412851-0-OSC2	1			POWER SUPPLY	-	A	B	
D-MD-5012850-0-0	7			DRILL & ETCH DRAWING	B	C	C	
		5012850			ETCH CIRCUIT BOARD	C	D	D
K-PC-5412851-0-DBC	-			P.C. DESIGN DATA BASE	A	B	B	
NOTES:								
REVISIONS								
THIS DRAWING IS THE PROPERTY OF DIGITAL AND IS NOT TO BE REPRODUCED OR USED IN ANY MANNER WITHOUT THE WRITTEN PERMISSION OF DIGITAL. © 1984	CHK CHANGE NO. REV			DRG. NO. DATE 22-JAN-88	ENG. DATE 22-JAN-88	SHEET 1 OF 1	TITLE: MASTER OSCILLATOR	
DSK: MROSDD.TPI(4,558) 22-JAN-88 14134 NEXT HIGHER ASSEMBLY:				NONE		SIZE D DD	NUMBER 5412851-0	REV. B
8	7	6	5	4	3	2	1	MR

COMPONENT SIDE VIEW

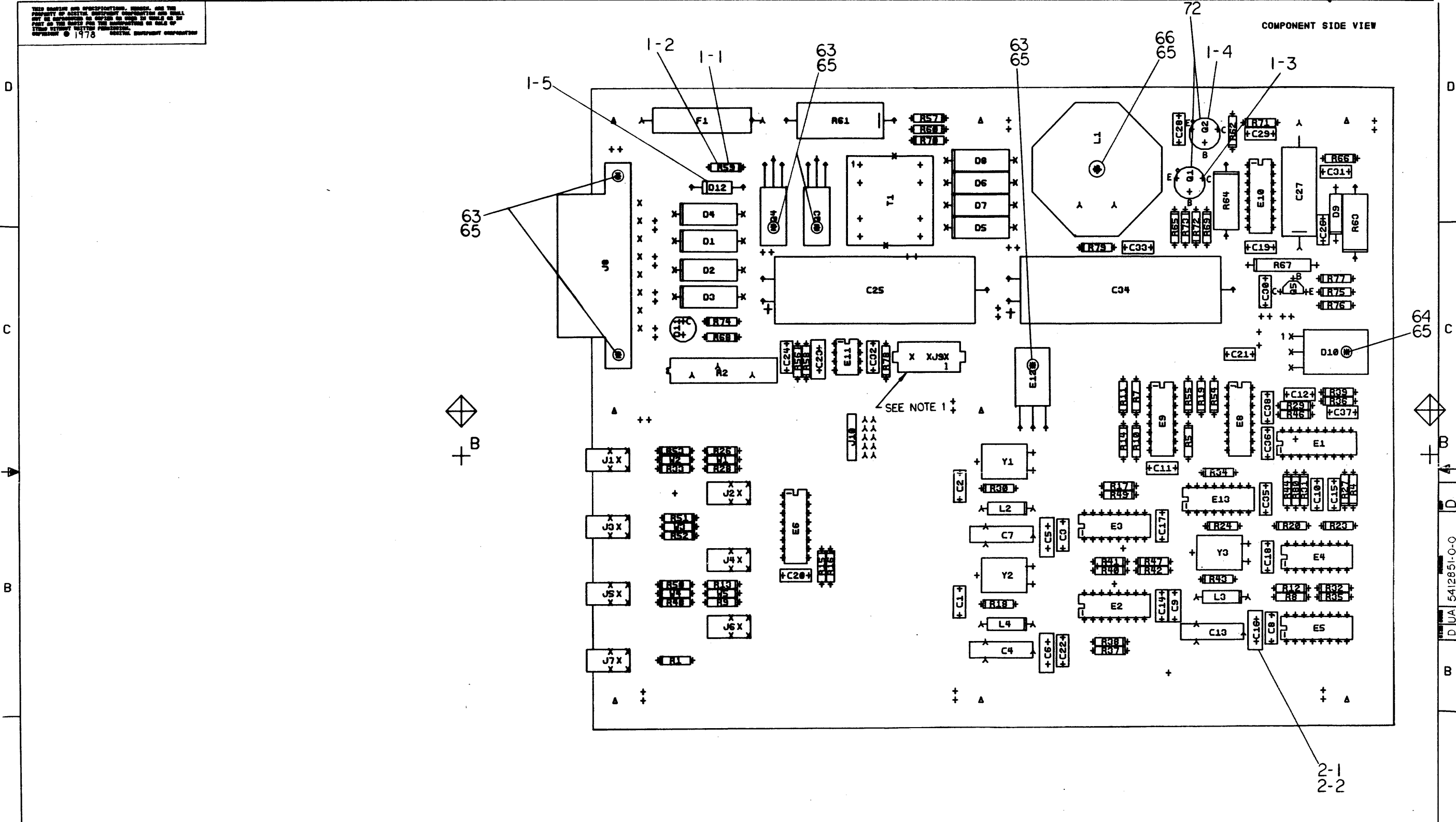

THIS DRAWING AND SPECIFICATIONS, HEREON, ARE THE PROPERTY OF DIGITAL EQUIPMENT CORPORATION AND SHALL NOT BE REPRODUCED OR TRANSMITTED IN ANY FORM OR BY ANY MEANS, ELECTRONIC OR MECHANICAL, INCLUDING PHOTOCOPYING, RECORDING, OR BY ANY INFORMATION STORAGE AND RETRIEVAL SYSTEM, WITHOUT PERMISSION IN WRITING FROM DIGITAL EQUIPMENT CORPORATION, SEPTEMBER © 1978

NOTES: 1. ITEM #71 CONNECTS TO J9 ON BOARD

CHANGE NO	REV	DATE	BY
5412851-1	C	1/24/78	...
...	...	...	...
...	...	...	...
...	...	...	...

ETCH REV.	C
P.C. DESIGN DATA BRSE REV.	C

SIGNATURES	DATE	digital
DRN. P. J. ...	1/24/78	
CHK'D. ...	1/24/78	
ENG. ...	7-21-78	
PROJ. ENG. ...	5-2-78	
PROD. ...	8-28-78	
SCALE 2/1	SIZE CODE	NUMBER
SHT. 1 OF 5	0 UA	5412851-0-0
NEXT HIGHER ASSY. D-DD-5412851-C		

2-1  
2-2

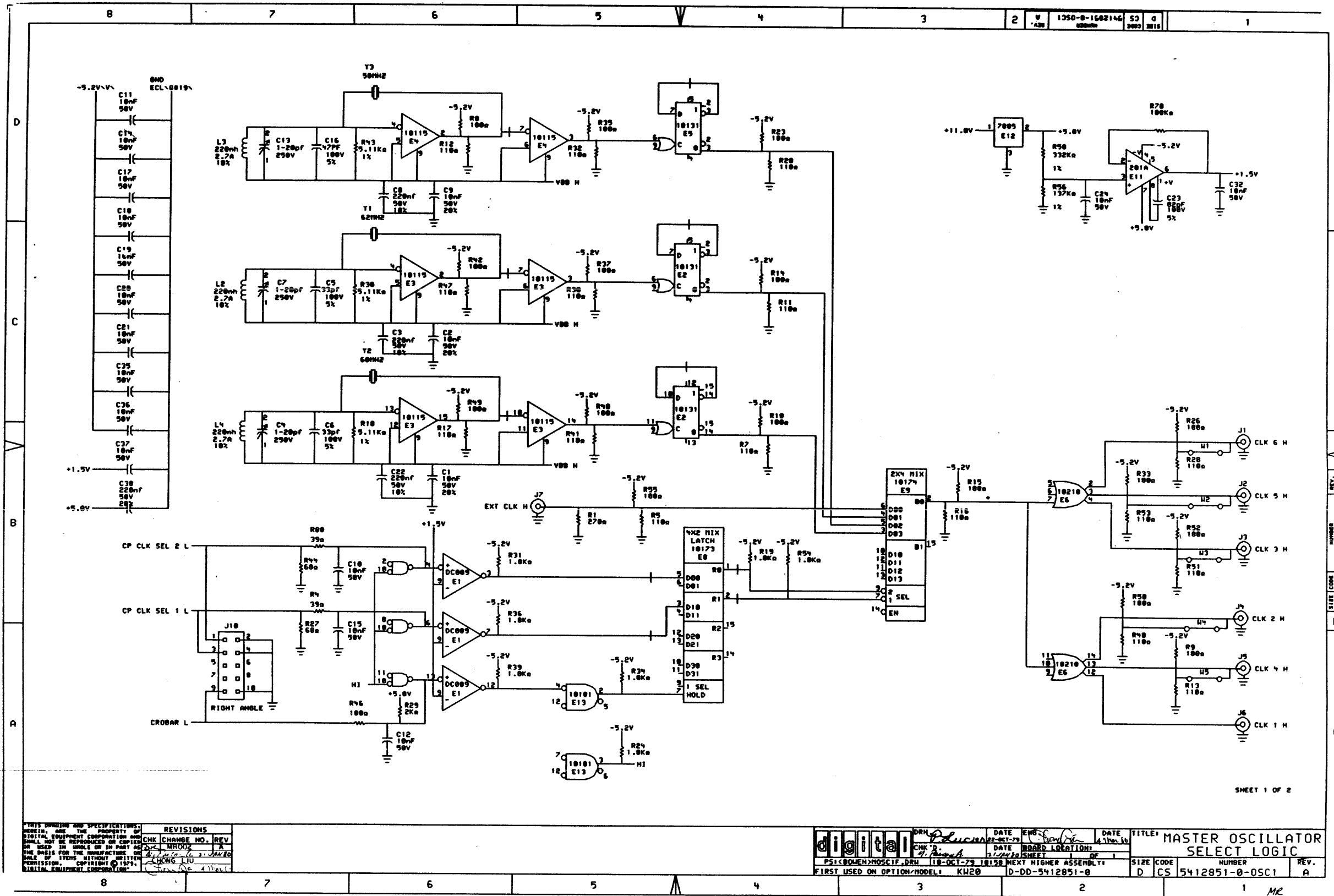

SHEET 1 OF 2

REVISIONS	
CHK	CHANGE NO. REV

	DRN	DATE	ENG	DATE	TITLE
	CHK	DATE	BOARD LOCATION	DATE	
PS1C0000EN00001F.DRW 118-OCT-79 18128 NEXT HIGHER ASSEMBLY FIRST USED ON OPTION-MODEL: KW20 D-DD-5412851-0					SIZE CODE NUMBER REV. D CS 5412851-0-0SC1 A

MK

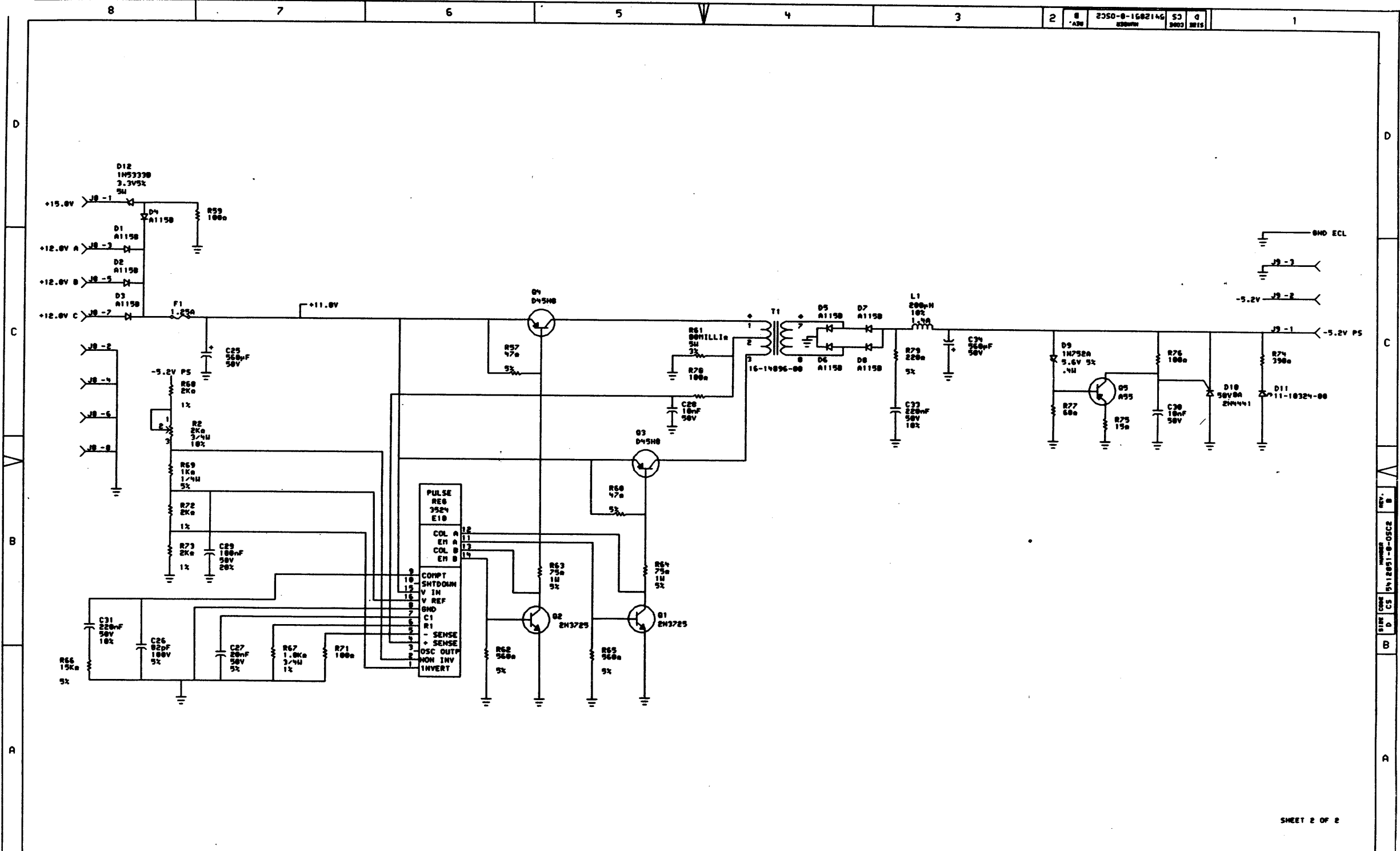

SHEET 2 OF 2

THIS DRAWING AND SPECIFICATIONS ARE THE PROPERTY OF DIGITAL EQUIPMENT CORPORATION AND SHALL NOT BE REPRODUCED OR COPIED OR USED IN WHOLE OR IN PART AS THE BASIS FOR THE MANUFACTURE OR SALE OF ITEMS WITHOUT WRITTEN PERMISSION. COPYRIGHT © 1973. DIGITAL EQUIPMENT CORPORATION

REV.	DATE	BY	CHK	CHANGE NO.
1	11-10-72	LLW	LLW	
2	11-10-72	LLW	LLW	

	DATE	11-10-72	DATE	11-10-72	TITLE	MASTER OSCILLATOR POWER SUPPLY
	DATE	11-10-72	DATE	11-10-72	SIZE	D CS
FIRST USED ON OPTION/MODEL:		KUR0		NEXT HIGHER ASSEMBLY:		
D-DD-5412851-0				NUMBER	5412851-0-OSCE	REV. B

MK

8 7 6 5 4 3 2 1

D  
C  
B  
A

D  
C  
B  
A

DRAWING NUMBER	PAGE	PART NO.	DESCRIPTION	REVISIONS	
			FILE: ORIGINAL LAYOUT		
			ECO NUMBER	1	
			MODULE REVISION	A	B
D-UA-M8572-0-0	5		CABLE BOARD	A	B
K-PL-M8572-0-DBP	1		PARTS LIST	A	B
K-PL-M8572-YA-DBP	1		PARTS LIST	A	A
D-CS-M8572-0-XCD1	1		CLK SEL LOGIC	-	-
D-CS-M8572-0-XCD2	1		XBUS CABLE	-	A
D-CS-M8572-0-XCD3	1		POWER AND GND	-	-
D-MD-5012820-0-0	5		DRILL & ETCH DRAWING	A	A
		5012820	ETCH CIRCUIT BOARD	D	D
K-PC-M8572-0-DBC	-		P.C. DESIGN DATA BASE	A	A

NOTES:

REV. A  
NUMBER  
M8572-0  
D  
DD  
B

CHK	CHANGE NO.	REV.
		A
		A

<b>digital</b>	DR. J. J. J.	DATE 11-DEC-78	ENG. SMITH	DATE 27-11-78	TITLE: CABLE BOARD
DSK1052200.12P14.9501	M. NORMAND	11-DEC-78 16:14	BOARD LOCATION: 1 OF 1	SIZE CODE D DD	NUMBER M8572-0
FIRST USED ON OPTION/MODEL: MF20		NONE	NEXT HIGHER ASSEMBLY:		REV. A

8 7 6 5 4 3 2 1

THIS DRAWING AND SPECIFICATIONS, HEREIN, ARE THE PROPERTY OF DIGITAL EQUIPMENT CORPORATION AND SHALL NOT BE REPRODUCED OR TRANSMITTED IN ANY FORM OR BY ANY MEANS, ELECTRONIC OR MECHANICAL, INCLUDING PHOTOCOPYING, RECORDING, OR BY ANY INFORMATION STORAGE AND RETRIEVAL SYSTEM, WITHOUT THE WRITTEN PERMISSION OF DIGITAL EQUIPMENT CORPORATION. © 1972

8 2-2-2298W 2 1  
13(QTY 12) COMPONENT SIDE VIEW

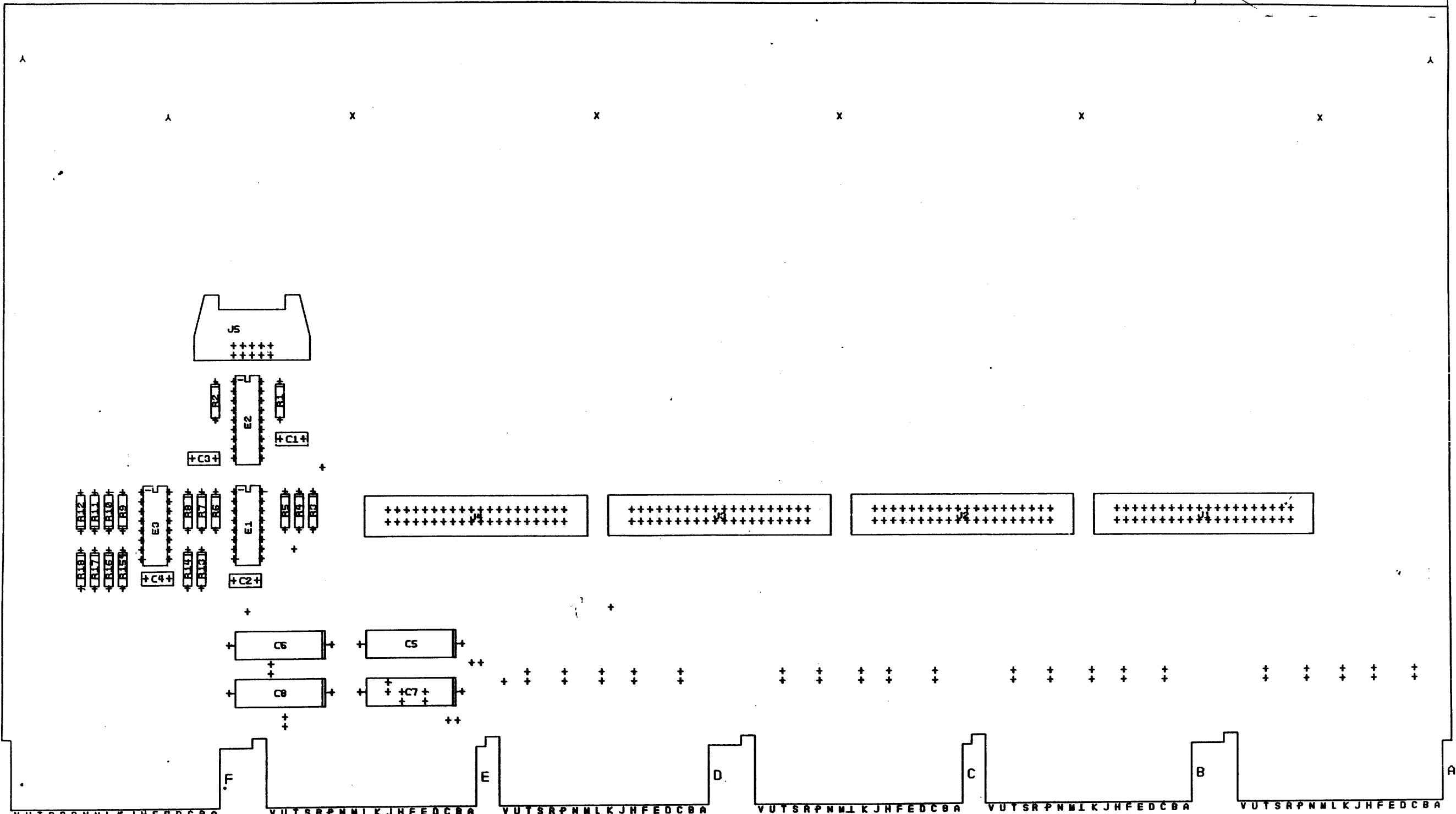

NOTES:  
 \_\_\_\_\_  
 \_\_\_\_\_  
 \_\_\_\_\_  
 \_\_\_\_\_  
 \_\_\_\_\_

CHANGE NO.	REV.	DATE	BY
1	A	5-27-72	W. J. BOWEN
2	B	6-27-72	W. J. BOWEN
3	C	7-27-72	W. J. BOWEN

ETCH REV.	D
P.C. DESIGN DATA BASE REV.	A

SIGNATURES		DATE	digital
DRN. <i>W. J. Bowen</i>		5-27-72	
CHK'D. <i>W. J. Bowen</i>		6-27-72	TITLE X-BUS CABLE BOARD
ENG. <i>W. J. Bowen</i>		7-27-72	
PROJ. ENG. <i>W. J. Bowen</i>		7-27-72	SIZE CODE NUMBER REV 0 UA M8572-0-0 S
PROD. <i>W. J. Bowen</i>		7-27-72	
SCALE 2/1			
SHT. 1 OF 5			
NEXT HIGHER ASSY. B-DD-M8572-0			

MR 1 MS# 104448

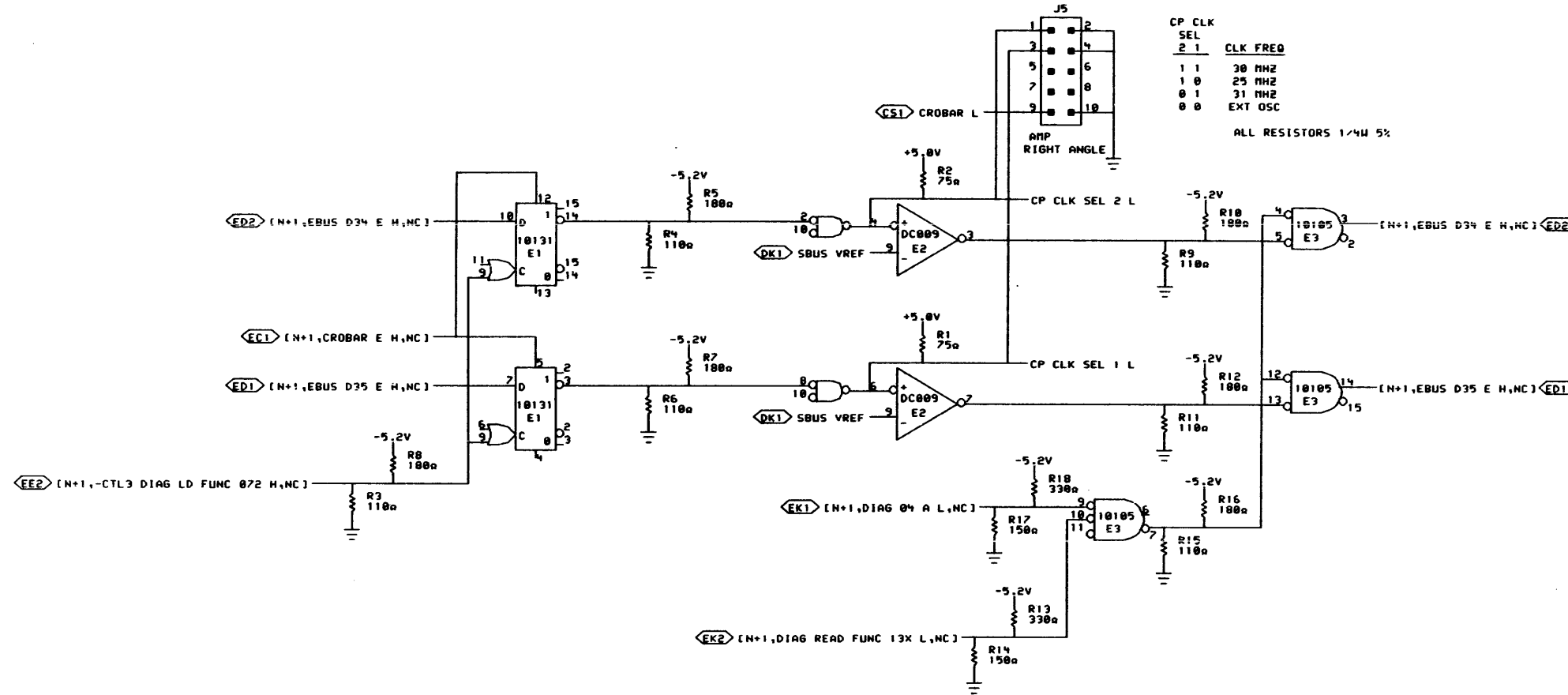

SHEET 1 OF 3

THIS DRAWING AND SPECIFICATIONS, HEREIN, ARE THE PROPERTY OF DIGITAL EQUIPMENT CORPORATION AND SHALL NOT BE REPRODUCED OR COPIED OR USED IN WHOLE OR IN PART AS THE BASIS FOR THE MANUFACTURE OR SALE OF ITEMS WITHOUT WRITTEN PERMISSION. COPYRIGHT © 1978 DIGITAL EQUIPMENT CORPORATION

REVISIONS		
CHK	CHANGE NO.	REV

digital	DRN	DATE	ENG	DATE	TITLE:
	CHK	26-JUL-78	Smith	6/14/78	CABLE BOARD CLK SEL LOGIC
PUB: M8572-N05 XCD1 EF.DRN 125-JUL-78 14249		DATE	BOARD LOCATION:	SIZE CODE NUMBER REV.	
FIRST USED ON OPTION/MODEL: MF20		SHEET 1 OF 1	D DD M8572-0		MR 1

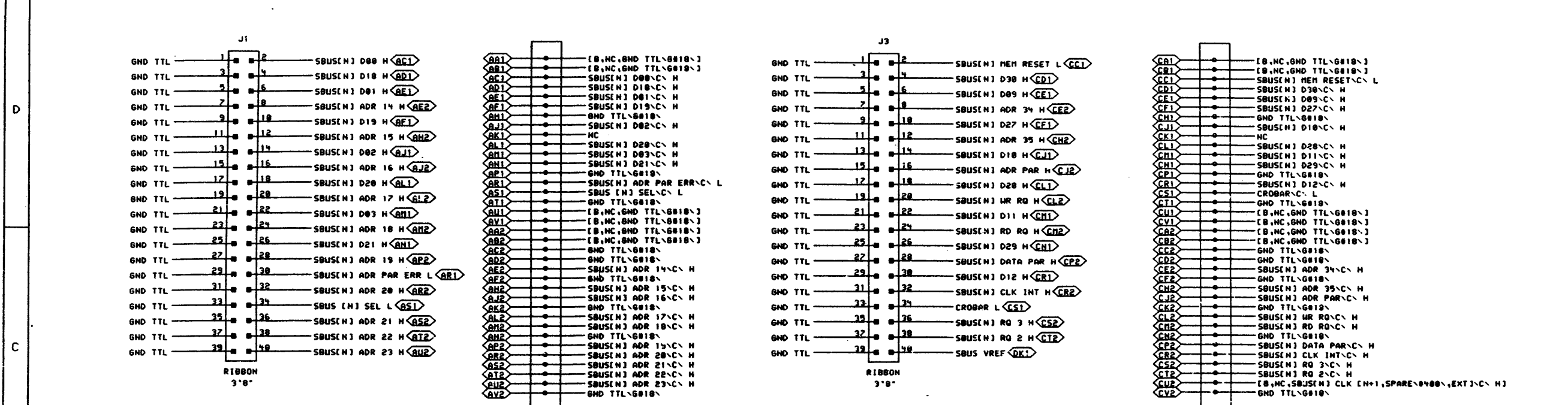

OPTION	CABLE LOCATION	VARIABLE
KL10	4AD02 4AD03	N = 0 N = 1

NOTE: SBUS1 CLK EXT (PIN CU2) IS NOT USED IN THE XBUS AND IS NOT CONNECTED ON THIS MODULE.

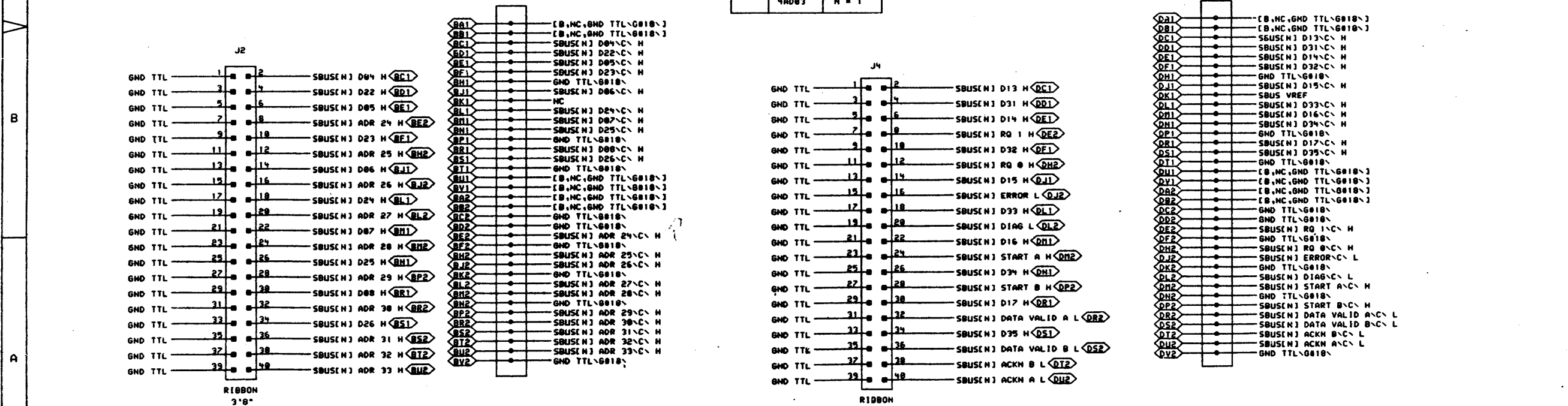

<small>THIS DRAWING AND SPECIFICATIONS ARE THE PROPERTY OF DIGITAL EQUIPMENT CORPORATION AND SHALL NOT BE REPRODUCED OR COPIED OR USED IN WHOLE OR IN PART HEREON OR FOR THE MANUFACTURE OR SALE OF ITEMS WITHOUT WRITTEN PERMISSION. COPYRIGHT © 1978, DIGITAL EQUIPMENT CORPORATION.</small>	REVISIONS CHG. CHANGE NO. REV. M8572-0-1A M8572-0-1B M8572-0-1C	DATE 15-NOV-78 ENG. C. SMITH DATE BOARD LOCATION: 7 JUL 79 SHEET 1 OF 1	TITLE: CABLE BOARD XBUS CABLE NUMBER: M8572-0-XCD2 REV. A	
	DIGITAL DRN. P. LUCAS CHK'D E. CALVO	DATE 15-NOV-78 ENG. C. SMITH DATE BOARD LOCATION: 7 JUL 79 SHEET 1 OF 1	TITLE: CABLE BOARD XBUS CABLE NUMBER: M8572-0-XCD2 REV. A	SIZE CODE: D CS FIRST USED ON OPTION/MODEL: MF20
	DATE 15-NOV-78 ENG. C. SMITH DATE BOARD LOCATION: 7 JUL 79 SHEET 1 OF 1	TITLE: CABLE BOARD XBUS CABLE NUMBER: M8572-0-XCD2 REV. A	SIZE CODE: D CS FIRST USED ON OPTION/MODEL: MF20	DATE 15-NOV-78 ENG. C. SMITH DATE BOARD LOCATION: 7 JUL 79 SHEET 1 OF 1

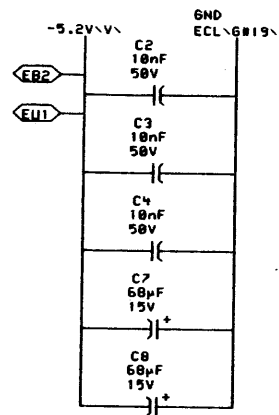
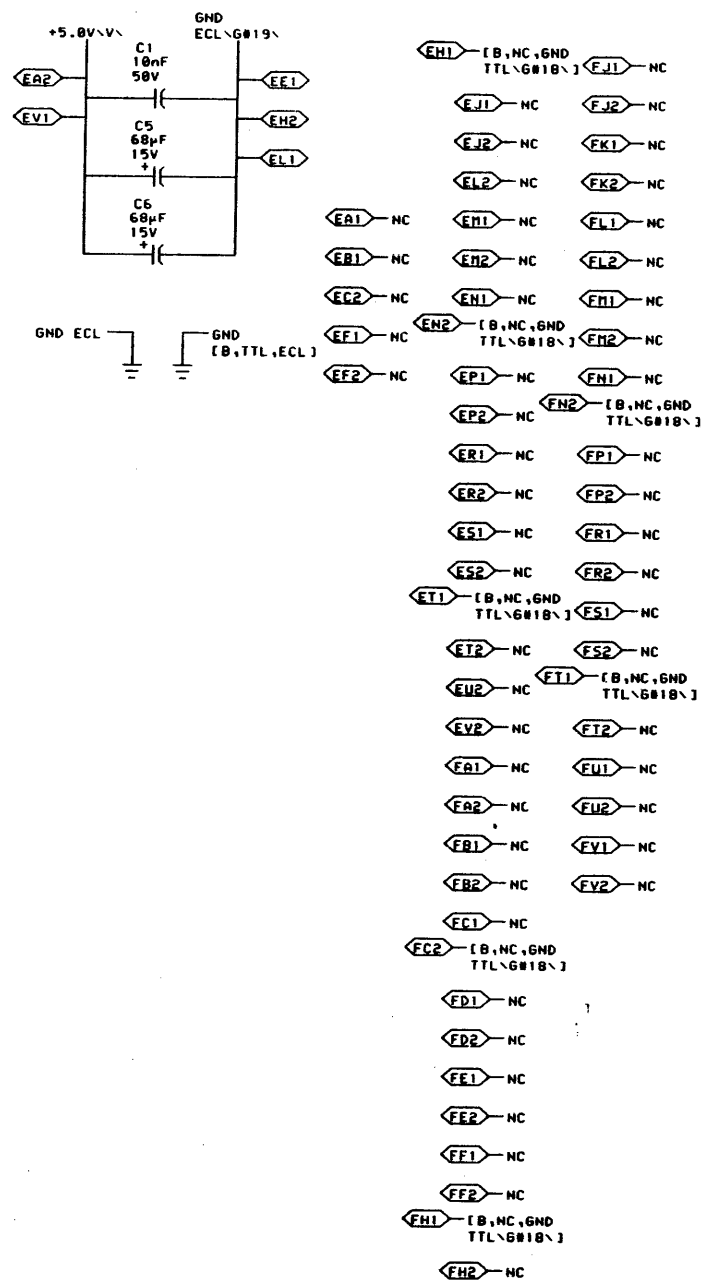

NOTE:

- ALL 74H SERIES LOGIC IS TO BE 1074H SERIES
- UNLESS OTHERWISE SPECIFIED THE FOLLOWING PIN NUMBERS APPLY:

GND	+5.0V	PACKAGE TYPE
8	16	16 PIN DIP
7	14	14 PIN DIP

- THE FOLLOWING PIN NUMBERS APPLY TO ECL DIP PACKAGES

GND	-5.2	+5.0V	MANUFACTURER'S PART NUMBER
1			ALL 10,000 SERIES UNLESS OTHERWISE SPECIFIED
16	8	NC	
1			
15			10110 & 10210
16	8	NC	
16	8	9	10124 & 10125

- THE FOLLOWING PIN NUMBERS APPLY TO DC009 DIP PACKAGES

GND	-5.2	+5.0V	MANUFACTURER'S PART NUMBER
5			
14	1	18	DC009

SHEET 3 OF 3

THIS DRAWING AND SPECIFICATIONS, HEREIN, ARE THE PROPERTY OF DIGITAL EQUIPMENT CORPORATION AND SHALL NOT BE REPRODUCED OR COPIED OR USED IN WHOLE OR IN PART AS THE BASIS FOR THE MANUFACTURE OR SALE OF ITEMS WITHOUT WRITTEN PERMISSION. COPYRIGHT © 1978, DIGITAL EQUIPMENT CORPORATION.

REVISIONS	
CHK	CHANGE NO. REV

digital	DATE	26-JUL-78	ENG	Smith	DATE	27-JUL-78	TITLE:	XBUS CABLE
	CHK'D	Smith	DATE	27-JUL-78	BOARD LOCATION:			POWER AND GND
PUB: M8572-MOS-XCD3EF.DRW	26-JUL-78	14:18	NEXT HIGHER ASSEMBLY:	B-DD-M8572-0	SIZE	CODE	NUMBER	REV.
FIRST USED ON OPTION/MODEL:	MF20				D	CS	M8572-0-XCD3	

DRAWING NUMBER	PAGE	PART NO.	DESCRIPTION	REVISIONS		
FILE: ORIGINAL LAYOUT						
ECO NUMBER				1	2	
MODULE REVISION				A	A	B
E-UA-M8574-0-0	4		WRITE PATH	A	A	B
K-PL-M8574-0-DBP	2		PARTS LIST	A	A	B
D-CS-M8574-0-WRP0	1		DATA 00-15	-	-	A
D-CS-M8574-0-WRP1	1		DATA 16-PAR	-	-	-
D-CS-M8574-0-WRP2	1		MIX AND LATCH A	-	-	-
D-CS-M8574-0-WRP3	1		MIX AND LATCH B	-	-	-
D-CS-M8574-0-WRP4	1		MIX AND LATCH C	-	-	-
D-05-M8574-0-WRP5	1		DATA BUFFER	-	-	-
D-CS-M8574-0-WRP6	1		ECC GENERATOR	-	-	-
D-CS-M8574-0-WRP7	1		ECC DIAG REG	-	-	-
D-CS-M8574-0-WRP8	1		SPARE BIT RAM	-	-	-
D-CS-M8574-0-WRP9	1		SPARE BIT MIXER	-	-	-
D-CS-M8574-0-WRPA	1		POWER. GND. CAPS.	-	-	-
D-CS-M8574-0-WRPB	1		POWER. GND. CAPS.	-	-	-
D-CS-M8574-0-RES	2		TERMINATORS	-	-	-
E-MD-5012898-0-0	5		DRILL & ETCH DRAWING	B	C	C
		5012898	ETCH CIRCUIT BOARD	C	C	C
K-PC-M8574-0-DBC	-		P.C. DESIGN DATA BASE	A	A	A
P00-M8574-00	-		PROCESS SHEET (REF ONLY)	-	-	-

NOTES:

THIS DRAWING AND SPECIFICATIONS ARE THE PROPERTY OF DIGITAL EQUIPMENT CORPORATION AND SHALL NOT BE REPRODUCED OR COPIED OR USED IN WHOLE OR IN PART AS THE BASIS FOR THE MANUFACTURE OR SALE OF ITEMS WITHOUT WRITTEN PERMISSION. COPYRIGHT © 1979. DIGITAL EQUIPMENT CORPORATION

REVISIONS	CHK	CHANGE NO.	REV

<b>digital</b>	DATE: 11-28-79	ENG: C. SMITH	DATE:	TITLE: WRITE PATH
DR: <i>C. Smith</i>	DATE: 11-28-79	BOARD LOCATION: SAF4	SHEET: 1 OF 1	
CHK: <i>C. Smith</i>	DATE: 11-28-79	NEXT HIGHER ASSEMBLY:	SIZE CODE: D DD	NUMBER: M8574-0
FIRST USED ON OPTION/MODEL: HF20	NONE			REV: B

COMPONENT SIDE VIEW

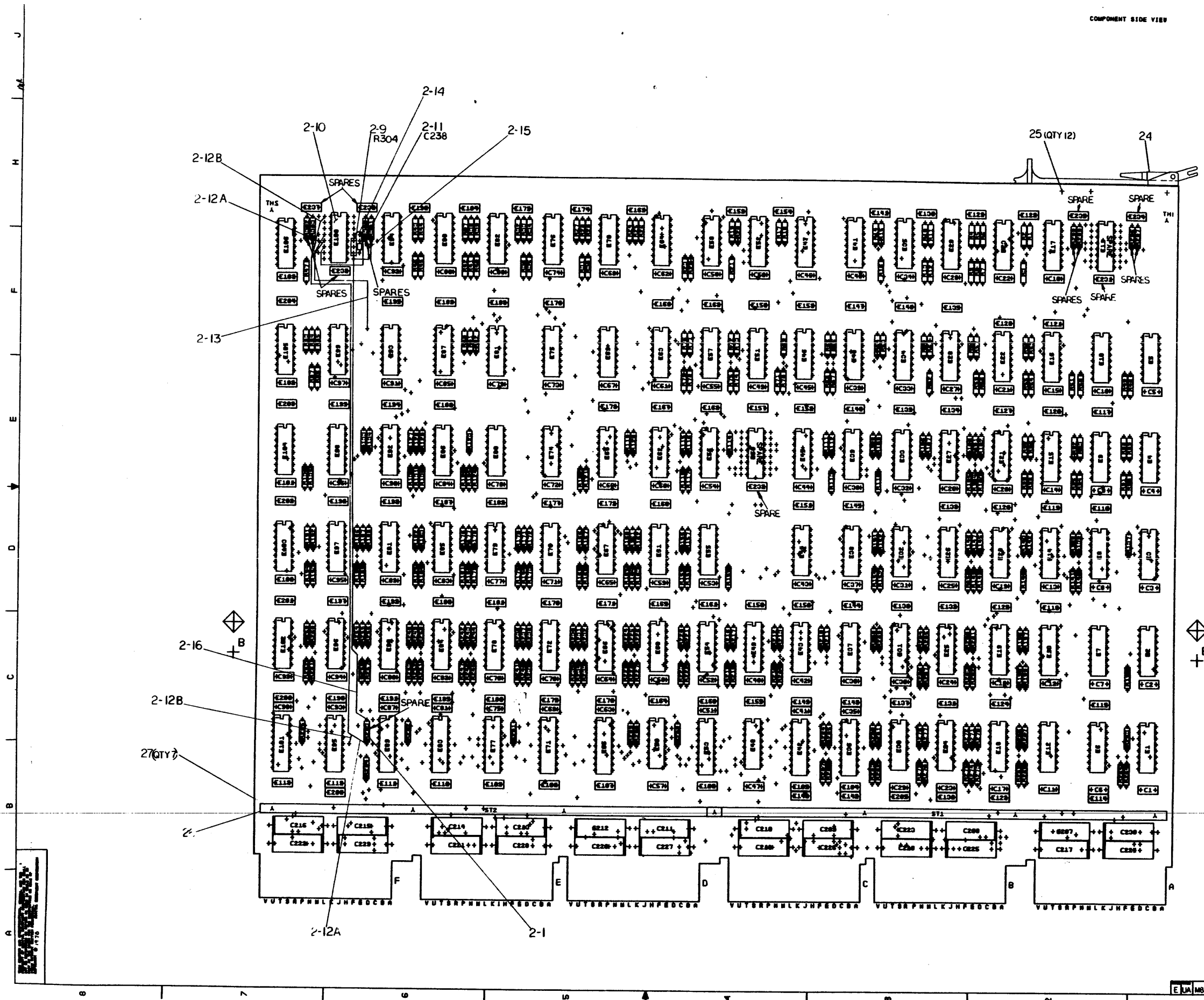

TITLE		WRITE PATH	
digital		EUA M8574 0-0 B	
DATE		REV	
BY		CHK	
DESIGNED		DRAWN	
CHECKED		APPROVED	
PART NUMBER		EUA M8574 0-0 B	
REV		REV	
BY		BY	
DATE		DATE	

NOTES: EXCEPT AS OTHERWISE SPECIFIED:	
1. UNLESS OTHERWISE SPECIFIED, ALL DIMENSIONS ARE IN MILLIMETERS.	
2. ALL DIMENSIONS ARE TO CENTER UNLESS OTHERWISE SPECIFIED.	
3. DIMENSIONS TO CENTER UNLESS OTHERWISE SPECIFIED.	
4. DIMENSIONS TO CENTER UNLESS OTHERWISE SPECIFIED.	
5. DIMENSIONS TO CENTER UNLESS OTHERWISE SPECIFIED.	

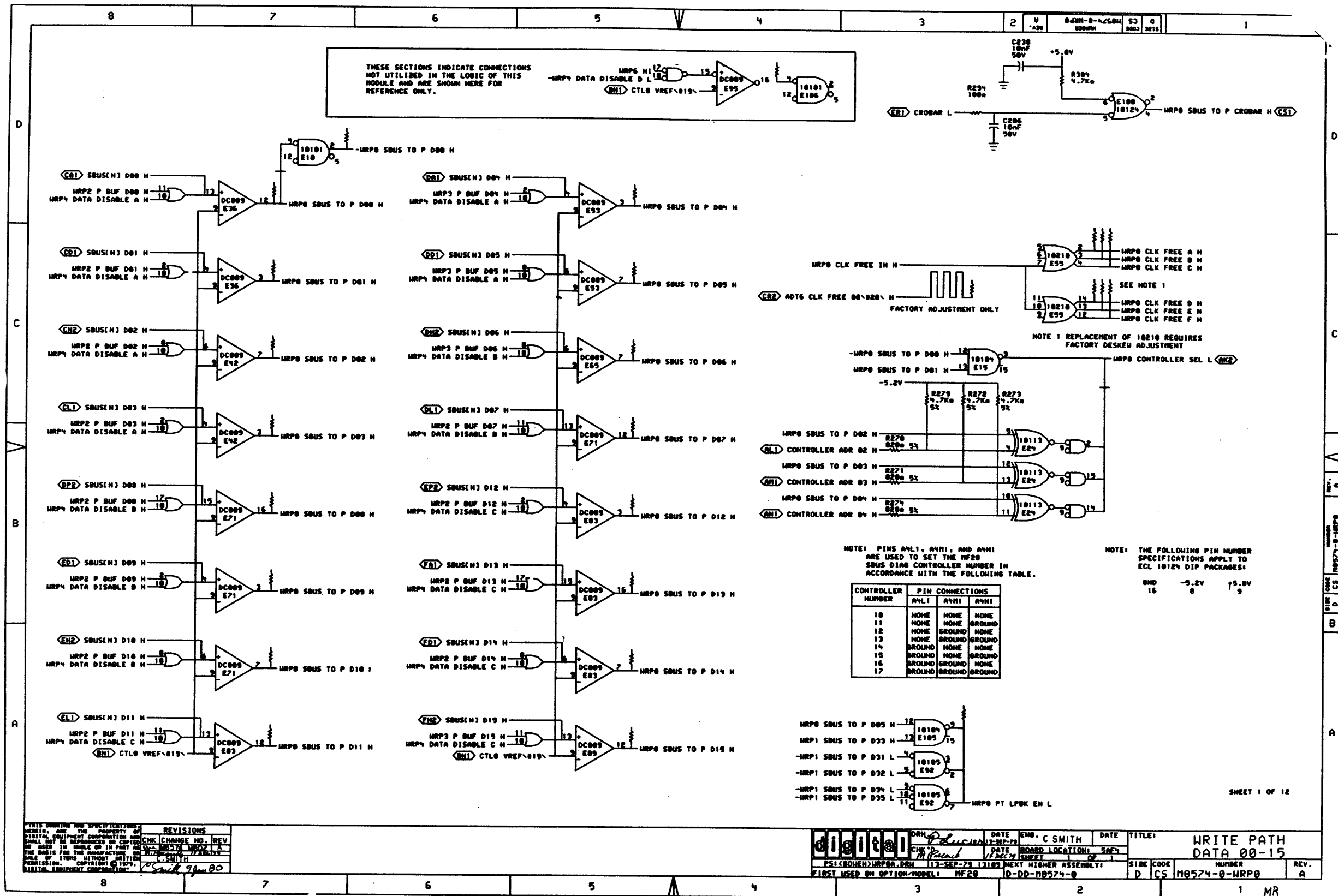

THESE SECTIONS INDICATE CONNECTIONS NOT UTILIZED IN THE LOGIC OF THIS MODULE AND ARE SHOWN HERE FOR REFERENCE ONLY.

NOTE 1 REPLACEMENT OF 10210 REQUIRES FACTORY DESKTOP ADJUSTMENT

NOTE: PINS A4L1, A4H1, AND A4H1 ARE USED TO SET THE MRP0 SBUS DIAG CONTROLLER NUMBER IN ACCORDANCE WITH THE FOLLOWING TABLE.

CONTROLLER NUMBER	A4L1	A4H1	A4H1
10	NONE	NONE	NONE
11	NONE	NONE	GROUND
12	NONE	GROUND	NONE
13	NONE	GROUND	GROUND
14	GROUND	NONE	NONE
15	GROUND	NONE	GROUND
16	GROUND	GROUND	NONE
17	GROUND	GROUND	GROUND

NOTE: THE FOLLOWING PIN NUMBER SPECIFICATIONS APPLY TO ECL 10124 DIP PACKAGES!

BND	-5.2V	+5.0V
16	0	9

THIS DRAWING AND SPECIFICATIONS ARE THE PROPERTY OF DIGITAL EQUIPMENT CORPORATION AND SHALL NOT BE REPRODUCED OR COPIED IN ANY MANNER OR USED IN WHOLE OR IN PART AS THE BASIS FOR THE MANUFACTURE OR SALE OF ITEMS WITHOUT WRITTEN PERMISSION. COPYRIGHT © 1974 DIGITAL EQUIPMENT CORPORATION

REVISIONS	DATE	BY
1	9/24/80	C. SMITH

DATE: 12-26-79	DATE: 12-26-79	DATE: 12-26-79	TITLE: WRITE PATH DATA 00-15
DESIGNER: C. SMITH	DATE: 12-26-79	DATE: 12-26-79	DATE: 12-26-79
PSI: BOHEN/HRP0A.DRM	113-SEP-79 13183	NEXT HIGHER ASSEMBLY: D-DD-M8574-0	SIZE CODE: D CS
FIRST USED ON OPTION/MODEL: MF20	NUMBER: M8574-0-MRP0	REV. A	

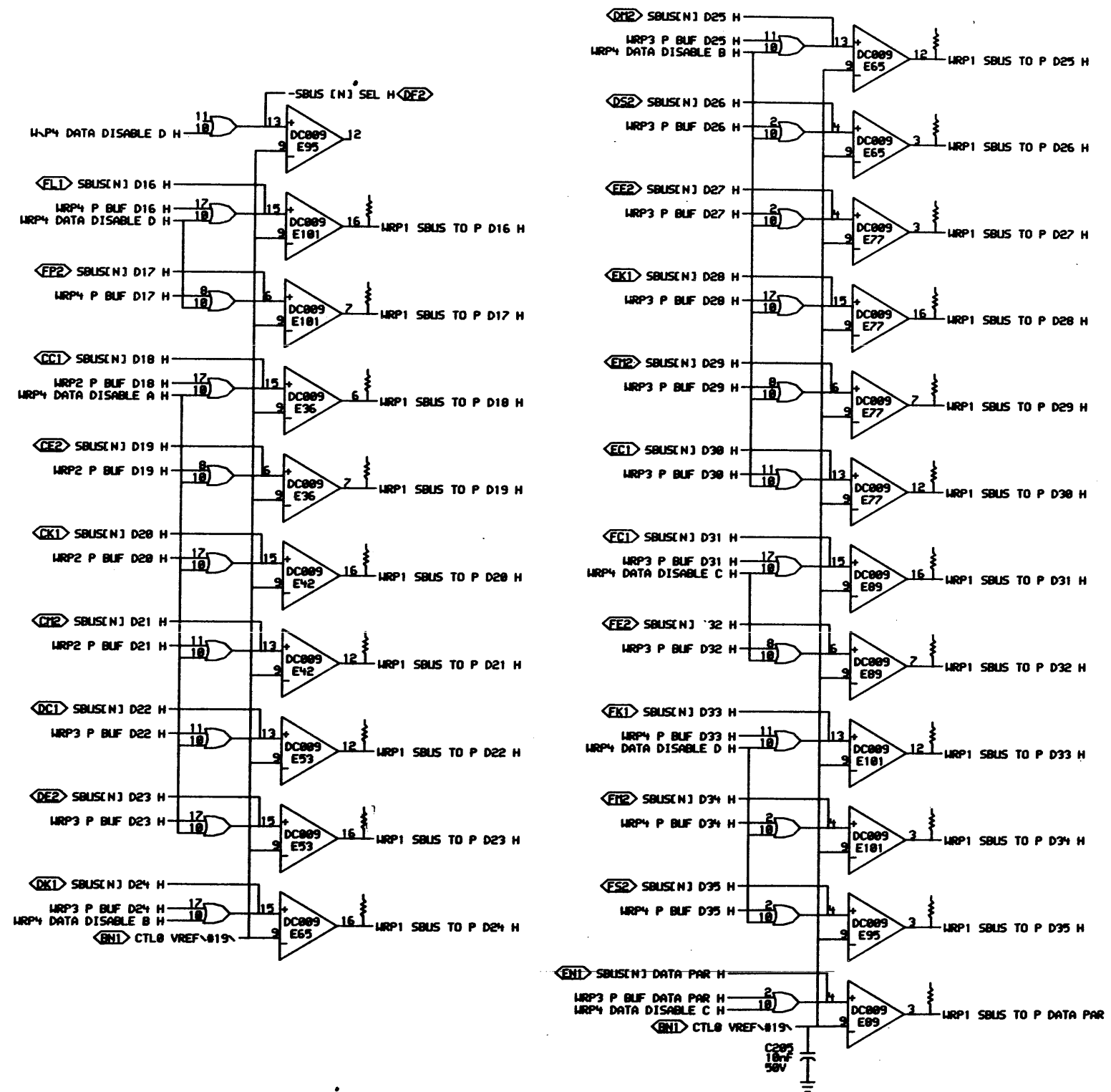

SHEET 2 OF 12

THIS DRAWING AND SPECIFICATIONS  
HEREIN ARE THE PROPERTY OF  
DIGITAL EQUIPMENT CORPORATION AND  
SHALL NOT BE REPRODUCED OR COPIED  
OR USED IN WHOLE OR IN PART AS  
THE BASIS FOR THE MANUFACTURE OR  
SALE OF ITEMS WITHOUT WRITTEN  
PERMISSION. COPYRIGHT © 1974  
DIGITAL EQUIPMENT CORPORATION

REVISIONS
CHK CHANGE NO. REV

<b>digital</b>	DRN <i>D. L. Chin</i>	DATE <i>2-18-78</i>	ENG. <i>D. L. Chin</i>	DATE <i>2-18-78</i>	TITLE: <b>WRITE PATH DATA 16-PAR</b>
		DATE <i>2-18-78</i>	BOARD LOCATION: <i>5A194</i>	DATE <i>2-18-78</i>	REV. <i>001</i>
FIRST USED ON OPTION MODEL: <i>MF20</i>			NEXT HIGHER ASSEMBLY: <i>10-DD-18574-0</i>		
SIZE CODE: <b>D CS</b>		NUMBER: <b>18574-0-WRP1</b>		REV. <i>mr</i>	

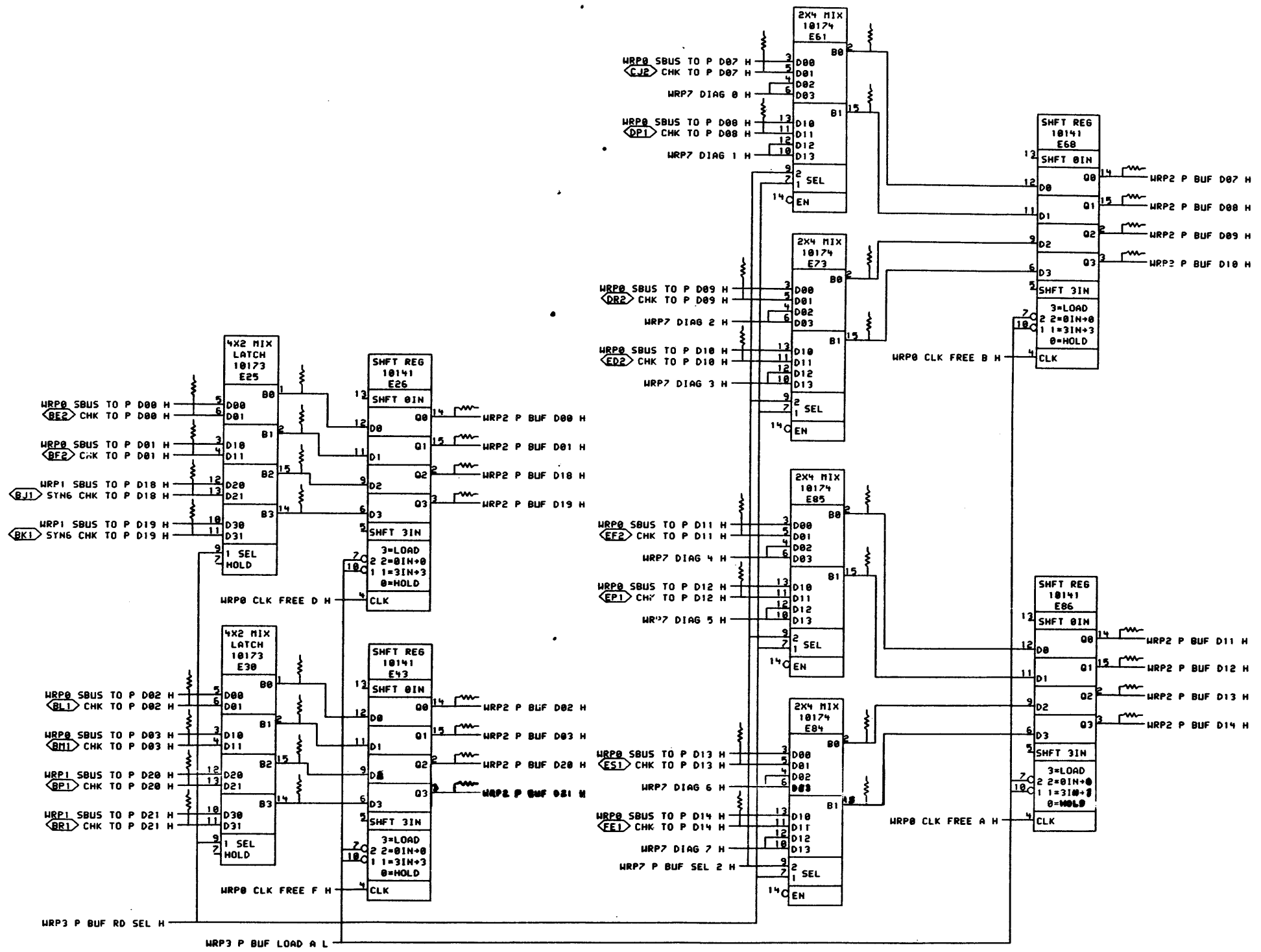

SHEET 3 OF 12

THIS DRAWING AND SPECIFICATIONS ARE THE PROPERTY OF DIGITAL EQUIPMENT CORPORATION AND SHALL NOT BE REPRODUCED OR COPIED OR USED IN WHOLE OR IN PART AS THE BASIS FOR THE MANUFACTURE OR SALE OF ITEMS WITHOUT WRITTEN PERMISSION. COPYRIGHT © 1978, DIGITAL EQUIPMENT CORPORATION.

REVISIONS		
CHK	CHANGE NO.	REV

	DRN <i>P. Luciani</i>	DATE 26-MAY-78	ENG <i>J. Chen</i>	DATE 29-MAY-78	TITLE: WRITE PATH MIX AND LATCH A
	CHK AD <i>P. Luciani</i>	DATE 126-MAY-78	BOARD LOCATION: 5AF04	SHEET 1 OF 1	
FIRST USED ON OPTION/MODEL: MF20		NEXT HIGHER ASSEMBLY: D-DD-M8574-0		SIZE CODE D CS	NUMBER M8574-0-WRP2

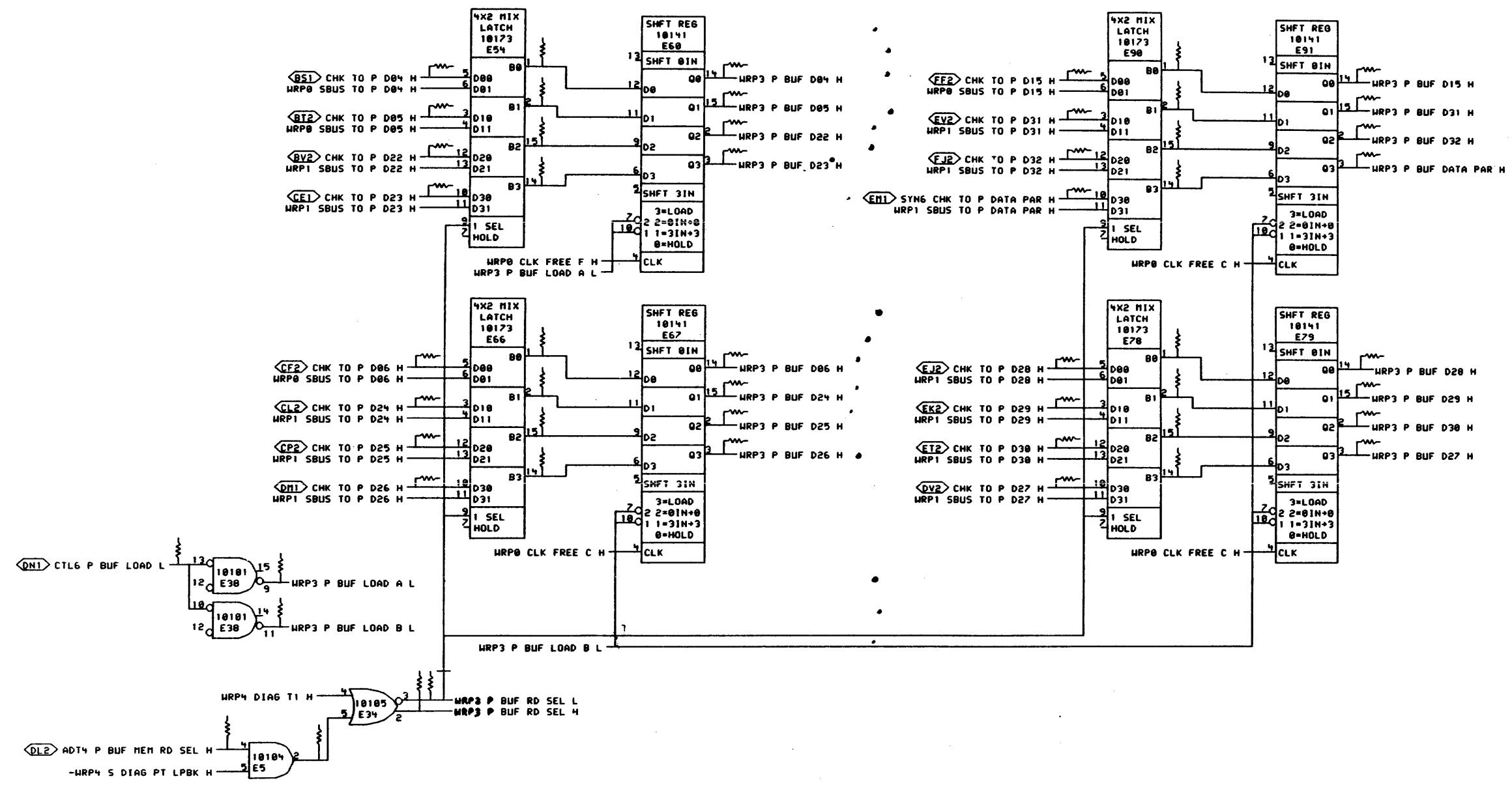

REV. 1  
NUMBER 10574-0-WRP3  
D 45  
SIZE CODE  
D

SHEET 4 OF 12

\*THIS DRAWING AND SPECIFICATIONS, HEREIN, ARE THE PROPERTY OF DIGITAL EQUIPMENT CORPORATION AND SHALL NOT BE REPRODUCED OR COPIED OR USED IN WHOLE OR IN PART AS THE BASIS FOR THE MANUFACTURE OR SALE OF ITEMS WITHOUT WRITTEN PERMISSION.  
COPYRIGHT © 1970, DIGITAL EQUIPMENT CORPORATION\*

REVISIONS	
CHK	CHANGE NO. REV

digital	DRN <i>P. Lucas</i>	DATE 27-FEB-78	ENG. <i>D.J. Chen</i>	DATE <i>28-FEB-78</i>	TITLE
	CHK'D <i>P. Lucas</i>	DATE 27-FEB-78	BOARD LOCATION	5AFB4	WRITE PATH MIX AND LATCH B
WRP3A DRU4,664		28-APR-78 07:21	NEXT HIGHER ASSEMBLY:	SIZE CODE	NUMBER
FIRST USED ON OPTION/MODEL: MF20		D-DD-10574-0		D CS	10574-0-WRP3

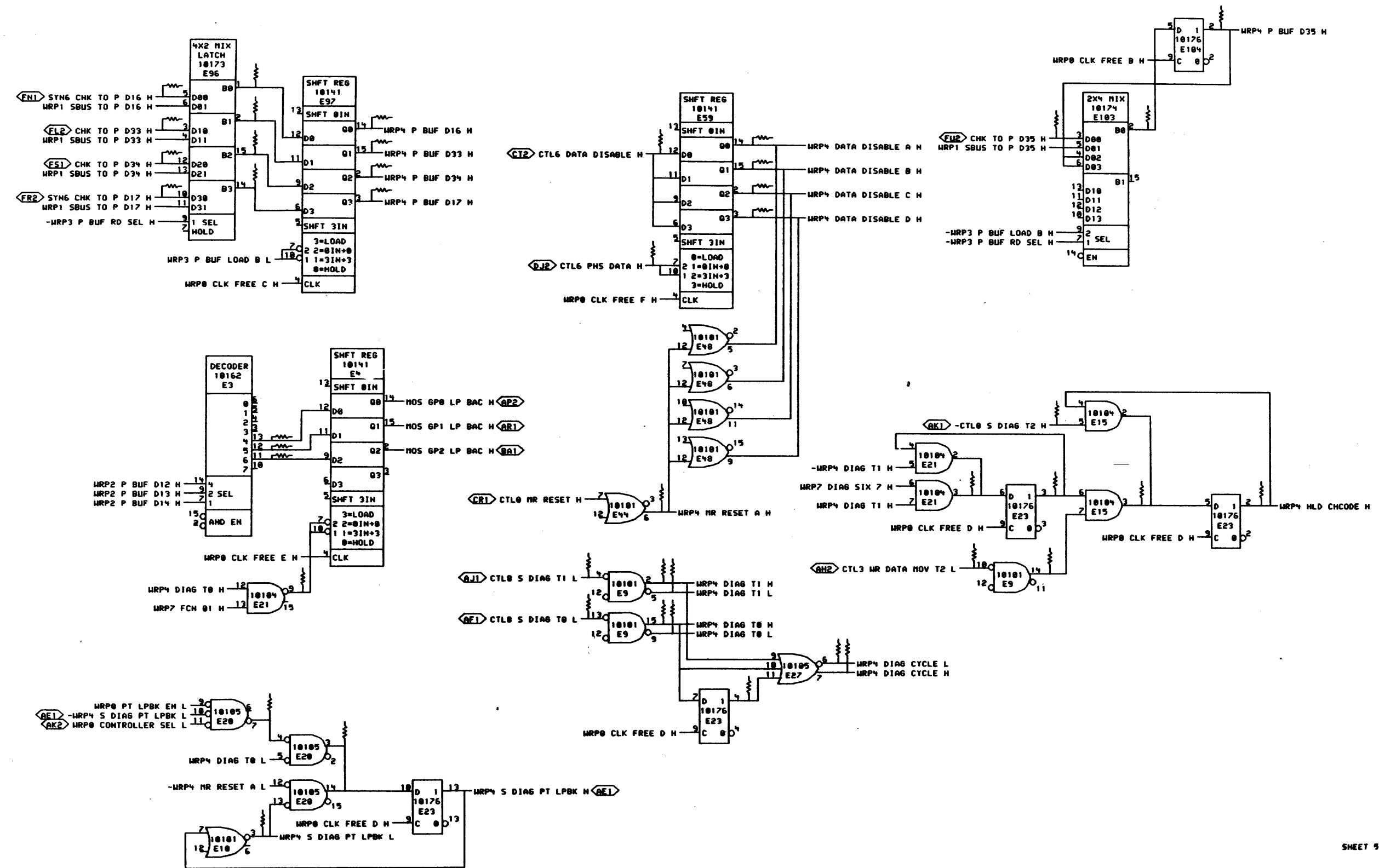

SHEET 5 OF 12

"THIS DRAWING AND SPECIFICATIONS, HEREIN, ARE THE PROPERTY OF DIGITAL EQUIPMENT CORPORATION AND SHALL NOT BE REPRODUCED OR COPIED OR USED IN WHOLE OR IN PART AS THE BASIS FOR THE MANUFACTURE OR SALE OF ITEMS WITHOUT WRITTEN PERMISSION. COPYRIGHT © 1976, DIGITAL EQUIPMENT CORPORATION"

REVISIONS	
CHK	CHANGE NO. REV

	DATE	ENG. 1	DATE	TITLE:
	24-FEB-79	Chin	24-FEB-79	WRITE PATH MIX AND LATCH C
CHK'D	DATE	BOARD LOCATION:	SHEET	OF
1	27-MAY-79	3A804	1	1
FIRST USED ON OPTION/MODEL: MF20				D-DD-M8574-0
SIZE	CODE	NUMBER	REV.	
D	CS	M8574-0-WRP4		

SDR-8-42584 53 0  
3002 3E15

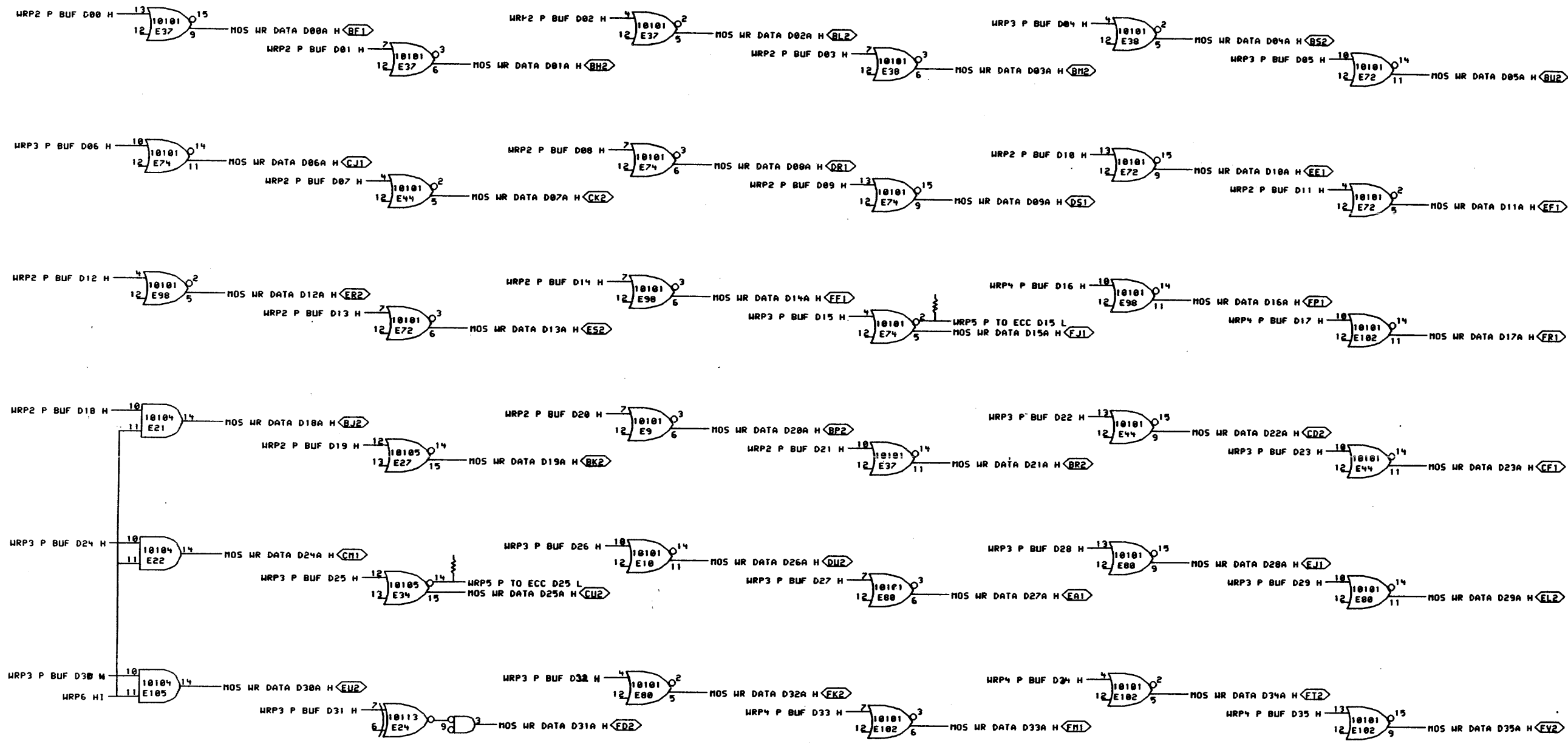

"THIS DRAWING AND SPECIFICATIONS, HEREIN, ARE THE PROPERTY OF DIGITAL EQUIPMENT CORPORATION AND SHALL NOT BE REPRODUCED OR COPIED OR USED IN WHOLE OR IN PART AS THE BASIS FOR THE MANUFACTURE OR SALE OF ITEMS WITHOUT WRITTEN PERMISSION.  
 COPYRIGHT © 1978, DIGITAL EQUIPMENT CORPORATION"

REVISIONS	
CHK	CHANGE NO. REV

digital	DRN: <i>P. Lucier</i>	DATE: 24-FEB-78	ENG: <i>J. Chen</i>	DATE: 24-FEB-78	TITLE: WRITE PATH DATA BUFFER
	CHK: <i>D. J. C. (M)</i>	DATE: 22-MAR-78	BOARD LOCATION: SAF04	SHEET 1 OF 1	SIZE CODE: D CS
FIRST USED ON OPTION/MODEL: MF20		NEXT HIGHER ASSEMBLY: D-DD-M8574-0		NUMBER: ml	REV.:

SIZE CODE	NUMBER	REV.
D CS	M8574-0-WRP5	

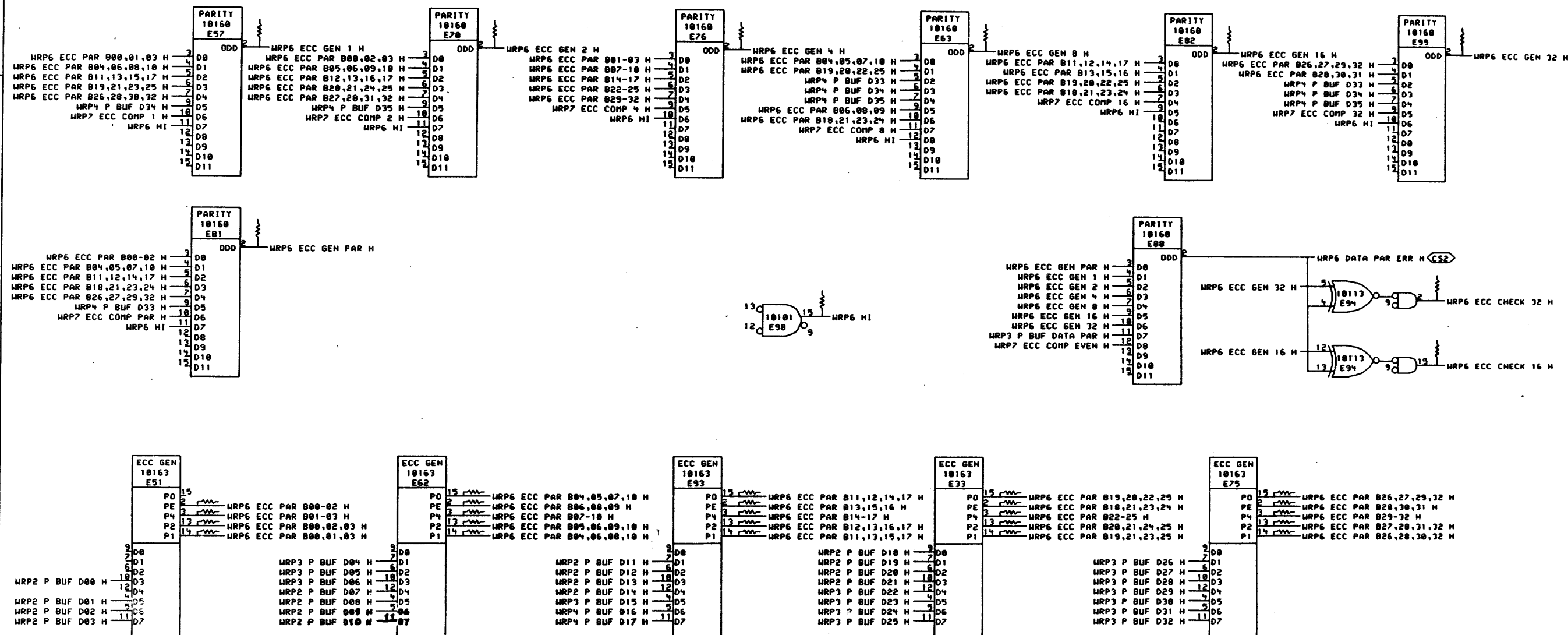

THIS DRAWING AND SPECIFICATIONS, HEREIN, ARE THE PROPERTY OF DIGITAL EQUIPMENT CORPORATION AND SHALL NOT BE REPRODUCED OR COPIED OR USED IN WHOLE OR IN PART AS THE BASIS FOR THE MANUFACTURE OR SALE OF ITEMS WITHOUT WRITTEN PERMISSION.  
 COPYRIGHT © 1970, DIGITAL EQUIPMENT CORPORATION

REVISIONS		
CHK	CHANGE NO.	REV

	DRAWN	DATE	ENG.	DATE	TITLE
	CHKD	DATE			
FIRST USED ON OPTION/MODEL: MF20		NEXT HIGHER ASSEMBLY: D-DD-M8574-0		BOARD LOCATION: 5A84	

SIZE	CODE	NUMBER	REV.
D	CS	M8574-0-WRP6	

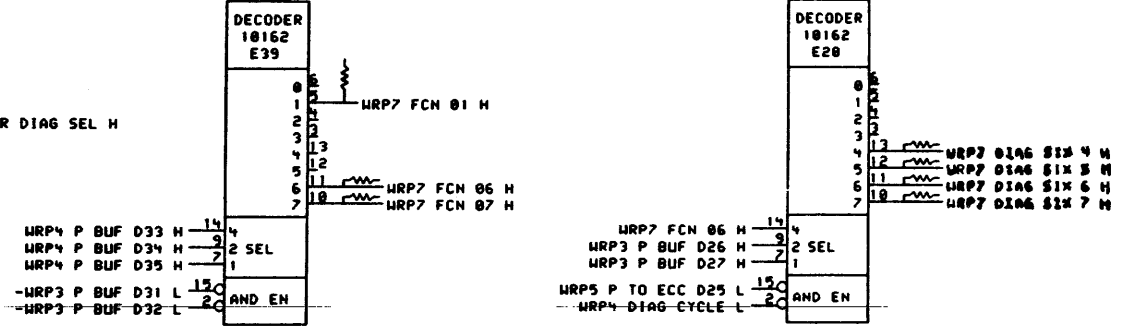
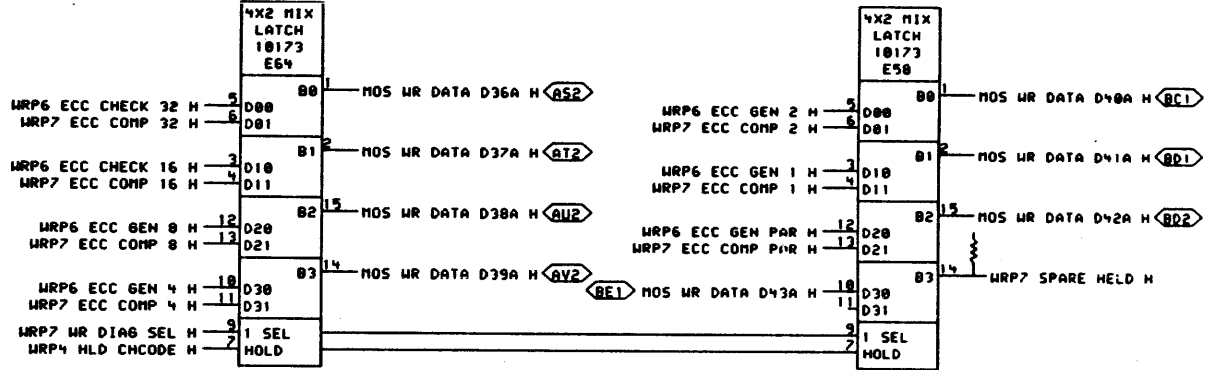
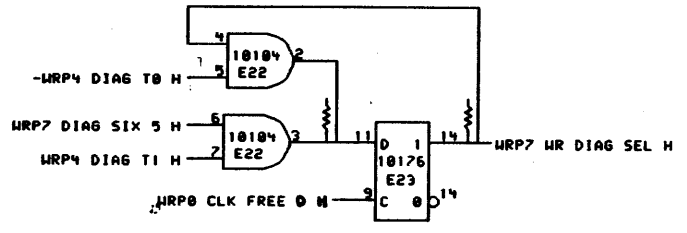
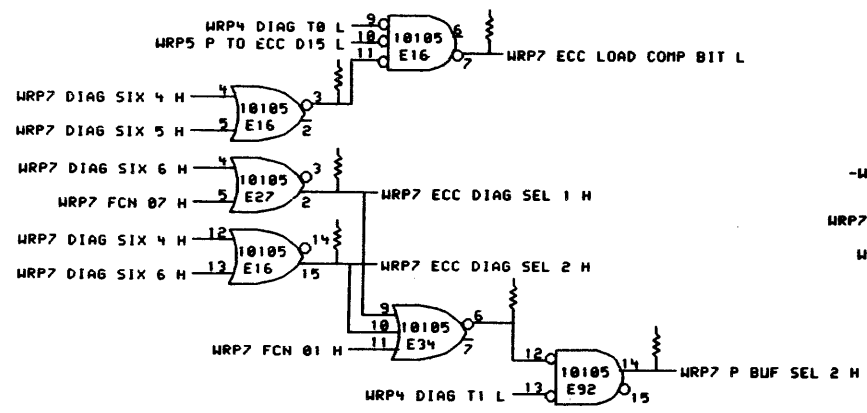
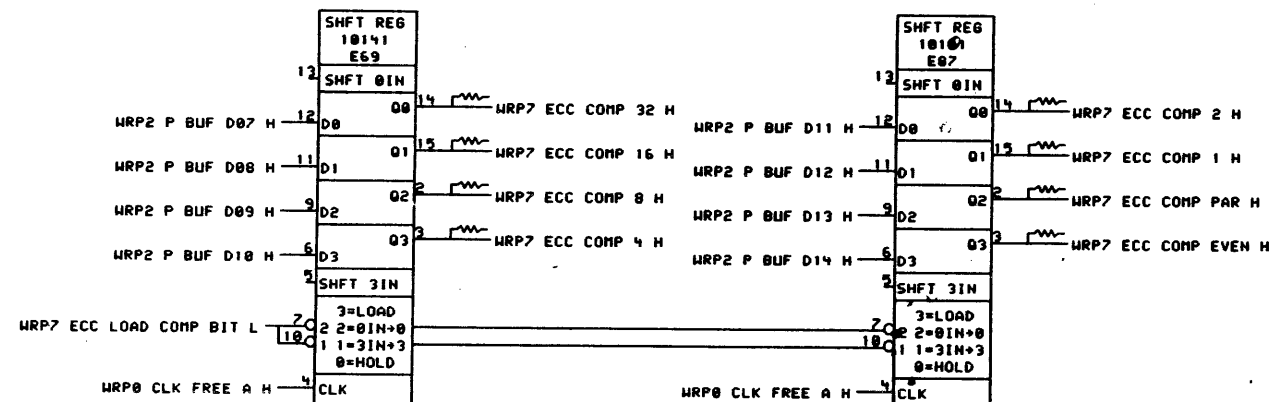
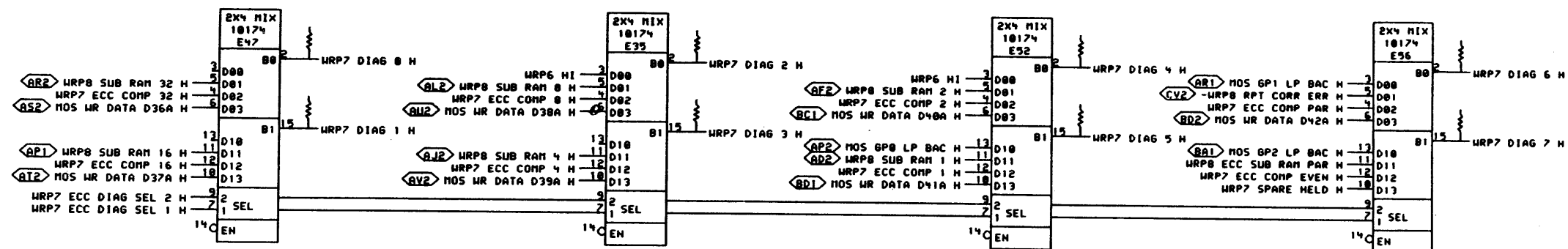

"THIS DRAWING AND SPECIFICATIONS, HEREIN, ARE THE PROPERTY OF DIGITAL EQUIPMENT CORPORATION AND SHALL NOT BE REPRODUCED OR COPIED OR USED IN WHOLE OR IN PART AS THE BASIS FOR THE MANUFACTURE OR SALE OF ITEMS WITHOUT WRITTEN PERMISSION. COPYRIGHT © 1978, DIGITAL EQUIPMENT CORPORATION"

REVISIONS		
CHK	CHANGE NO.	REV

digital	DRN	DATE	ENG.	DATE	TITLE
	CHK'D	22-JUN-78	J. J. ...	24-JUN-78	WRITE PATH ECC DIAG REG
WRP7A.DRW(4,664)		104-MAY-78 13:45	NEXT HIGHER ASSEMBLY:		SIZE CODE
FIRST USED ON OPTION/MODEL: MF20		D-DD-M8574-0		D	CS

NUMBER	REV.
M8574-0-WRP7	

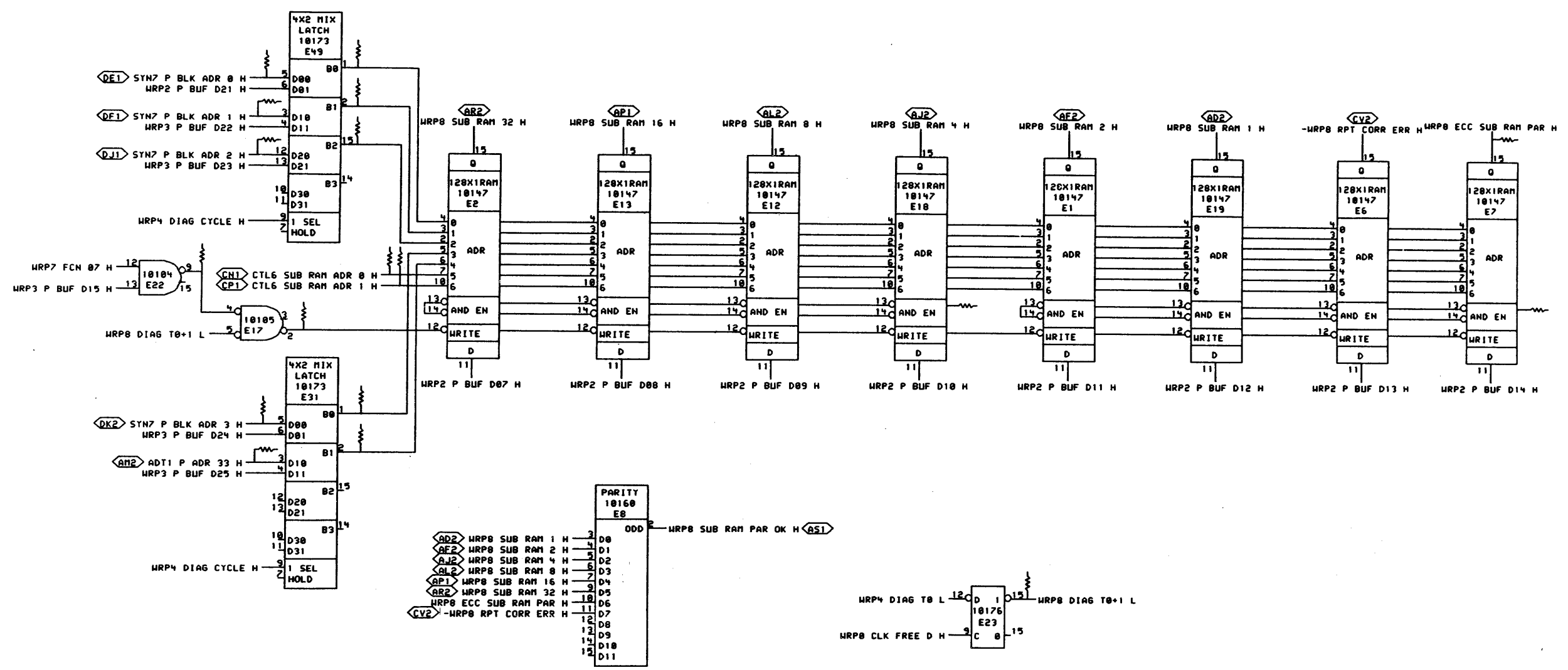

SHEET 9 OF 12

"THIS DRAWING AND SPECIFICATIONS, HEREIN, ARE THE PROPERTY OF DIGITAL EQUIPMENT CORPORATION AND SHALL NOT BE REPRODUCED OR COPIED OR USED IN WHOLE OR IN PART AS THE BASIS FOR THE MANUFACTURE OR SALE OF ITEMS WITHOUT WRITTEN PERMISSION. COPYRIGHT © 1970, DIGITAL EQUIPMENT CORPORATION"

REVISIONS	
CHK	CHANGE NO. REV

<b>digital</b>	DRN <i>P. Luciani</i>	DATE 24-FEB-78	ENG. <i>J. Allen</i>	DATE 24-FEB-78	TITLE: WRITE PATH SPARE BIT RAM
	CHKD <i>P. Luciani</i>	DATE 22-MAR-78	BOARD LOCATION: 58F04	SHEET 1 OF 1	SIZE CODE NUMBER REV.
WRP8A.DRW(4,654)		128-APR-78 07:22	NEXT HIGHER ASSEMBLY: D-DD-M8574-0	0 CS	M8574-0-WRP8
FIRST USED ON OPTION/MODEL: MF20					

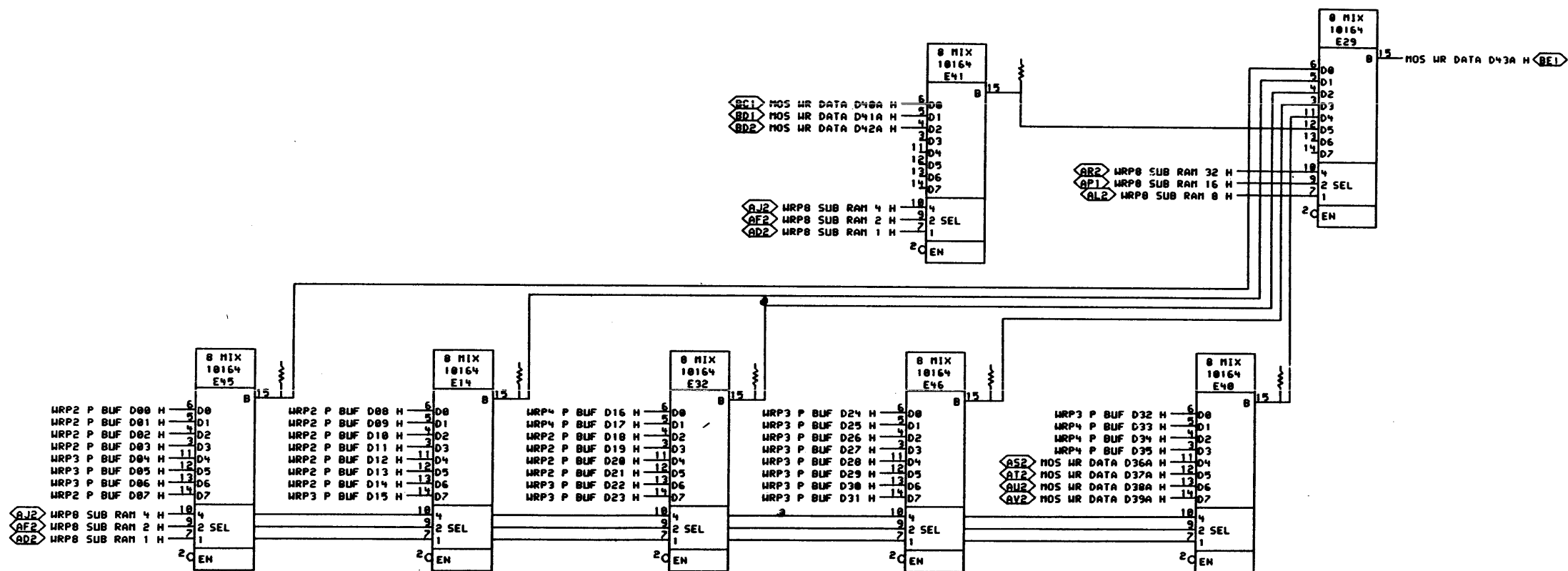

THIS DRAWING AND SPECIFICATIONS HEREIN ARE THE PROPERTY OF DIGITAL EQUIPMENT CORPORATION AND SHALL NOT BE REPRODUCED OR COPIED OR USED IN WHOLE OR IN PART AS THE BASIS FOR THE MANUFACTURE OR SALE OF ITEMS WITHOUT WRITTEN PERMISSION. COPYRIGHT © 1976. DIGITAL EQUIPMENT CORPORATION.

REVISIONS		
CHK	CHANGE NO.	REV

<b>digital</b>	DRN <i>P. Lucian</i>	DATE 31-MAY-78	ENG. <i>J. Chen</i>	DATE 6-JUN-78	TITLE: WRITE PATH SPARE BIT MIXER
	CHK <i>P. Lucian</i>	DATE 27-JUN-78	BOARD LOCATION: 3AF04	OF 1	SIZE CODE NUMBER REV. D CS 18574-0-WRP9
FIRST USED ON OPTION/MODEL: MF20		NEXT HIGHER ASSEMBLY: D-DD-18574-0			

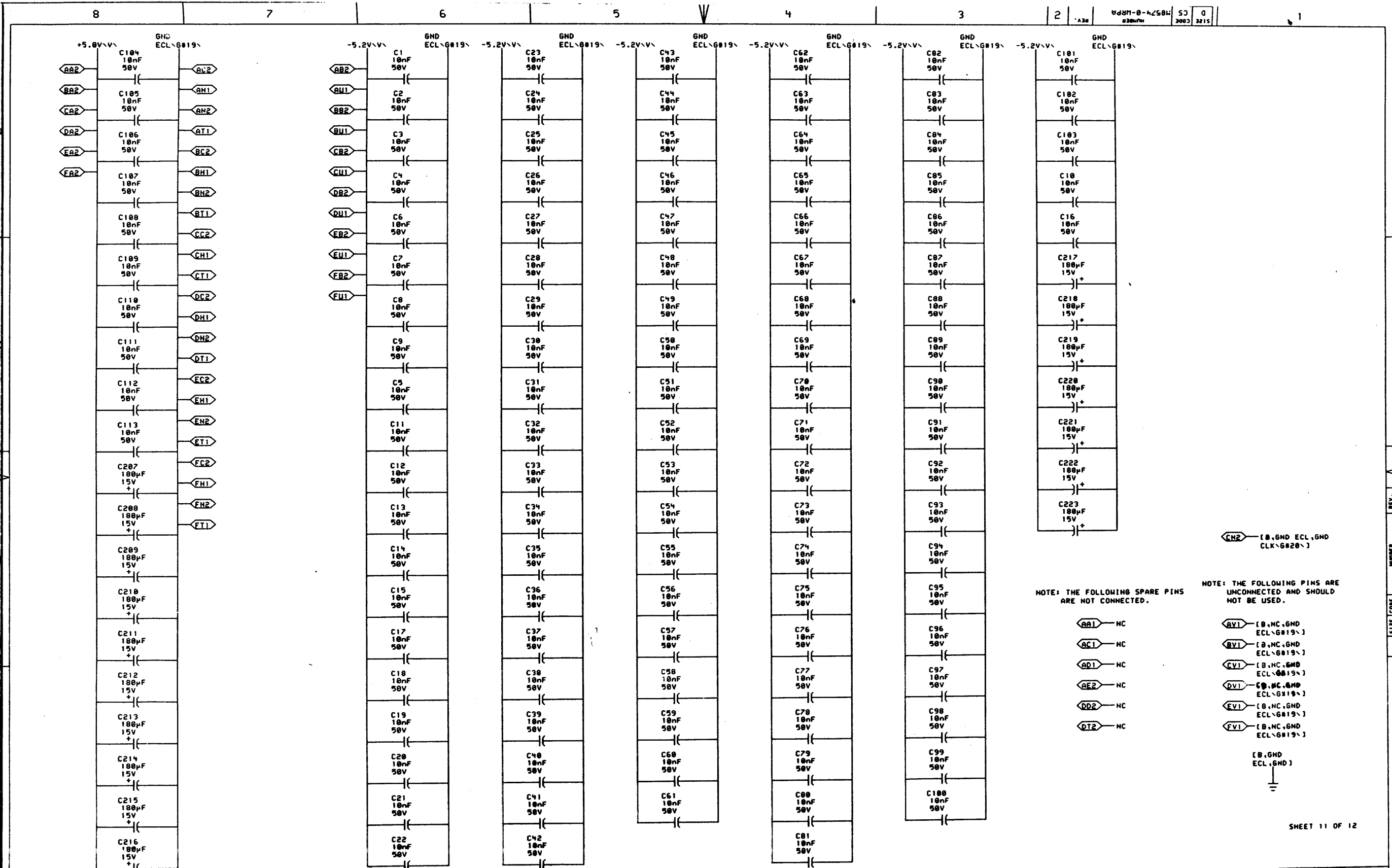

NOTE: THE FOLLOWING SPARE PINS ARE NOT CONNECTED.

- AB1 - NC
- AC1 - NC
- AD1 - NC
- AE2 - NC
- DD2 - NC
- DT2 - NC

NOTE: THE FOLLOWING PINS ARE UNCONNECTED AND SHOULD NOT BE USED.

- AV1 - [B,NC,GND ECL-G#19]
- BV1 - [B,NC,GND ECL-G#19]
- CV1 - [B,NC,GND ECL-G#19]
- DV1 - [B,NC,GND ECL-G#19]
- EV1 - [B,NC,GND ECL-G#19]
- FV1 - [B,NC,GND ECL-G#19]



THIS DRAWING AND SPECIFICATIONS HEREIN ARE THE PROPERTY OF DIGITAL EQUIPMENT CORPORATION AND SHALL NOT BE REPRODUCED OR COPIED OR USED IN WHOLE OR IN PART AS THE BASIS FOR THE MANUFACTURE OR SALE OF ITEMS WITHOUT WRITTEN PERMISSION. COPYRIGHT © 1975, DIGITAL EQUIPMENT CORPORATION

REVISIONS	
CHK	CHANGE NO. REV

digital	DRN <i>D. Lucas</i>	DATE 07-JUN-78	ENG. <i>J. Chen</i>	DATE 22-JUN-78	TITLE: WRITE PATH POWER, GND, CAPS.
	CHK <i>D. Lucas</i>	DATE 107-JUN-78	BOARD LOCATION: 3A8B4	SHEET 11 OF 12	SIZE CODE NUMBER REV.
FIRST USED ON OPTION/MODEL: MF20		NEXT HIGHER ASSEMBLY: D-DD-M8574-0		D CS M8574-0-WRPA	

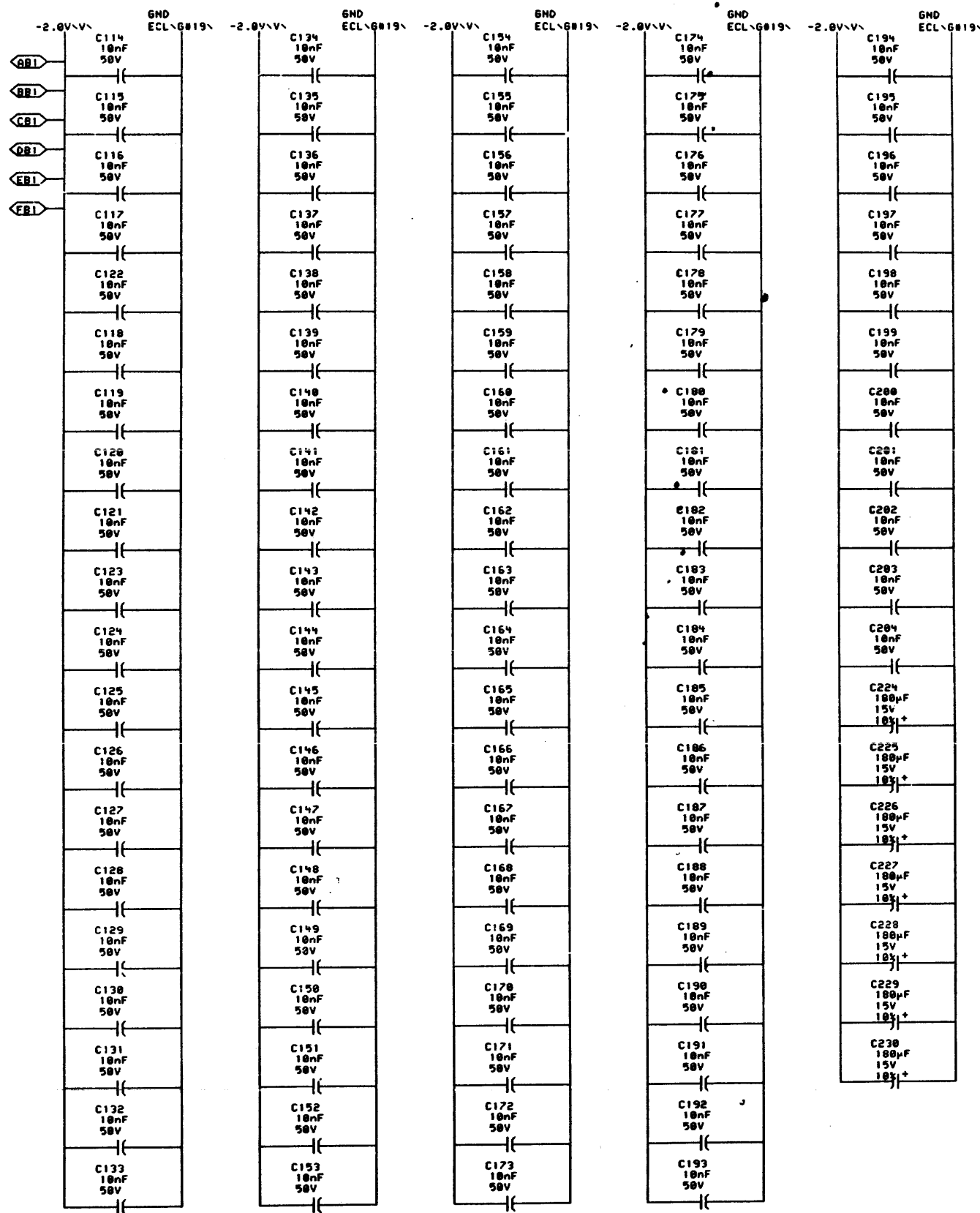

NOTE:  
 1. THE FOLLOWING PIN NUMBERS APPLY TO ECL DIP PACKAGES

GND	-5.2	MANUFACTURER'S PART NUMBER
1	8	ALL 10,000 SERIES UNLESS OTHERWISE SPECIFIED
15	8	10110 & 10210
16	8	10150 & 10173
1	12	10101
24		

THE FOLLOWING PIN NUMBERS APPLY TO DC009 DIP PACKAGES

GND	-5.2	+5.0V	MANUFACTURER'S PART NUMBER
5		10	DC009

THIS DRAWING AND SPECIFICATIONS HEREIN ARE THE PROPERTY OF DIGITAL EQUIPMENT CORPORATION AND SHALL NOT BE REPRODUCED OR COPIED OR USED IN WHOLE OR IN PART AS THE BASIS FOR THE MANUFACTURE OR SALE OF ITEMS WITHOUT WRITTEN PERMISSION. COPYRIGHT © 1970, DIGITAL EQUIPMENT CORPORATION.

REVISIONS	
CHK	CHANGE NO. REV

**digital** DRN: *Polunin* DATE: 07-JUN-70 ENG: *John* DATE:  TITLE: WRITE PATH POWER, GND, CAPS.

CHK:  DATE: 21-JUN-70 BOARD LOCATION: SAF84

MRPA: DRW(4,664) 07-JUN-70 11:18 NEXT HIGHER ASSEMBLY: SHEET 1 OF 1

FIRST USED ON OPTION/MODEL: MF20 D-DD-M8574-0

SIZE CODE: D CS NUMBER: M8574-0-WRPA REV.:

RESISTOR LOC(PIN)	SHOWN DRN#	ON REF	VALUE	TERMINATES SIGNAL	RESISTOR LOC(PIN)	SHOWN DRN#	ON REF	VALUE	TERMINATES SIGNAL	RESISTOR LOC(PIN)	SHOWN DRN#	ON REF	VALUE	TERMINATES SIGNAL	RESISTOR LOC(PIN)	SHOWN DRN#	ON REF	VALUE	TERMINATES SIGNAL
R263(1)	WRP8	C1	60a	XE1(13)	R220(1)	WRP3	C5	60a	XE54(15)	R172(1)	WRP2	C4	60a	CHK TO P D09 H	R209(1)	WRP8	B7	60a	SYN7 P BLK ADR 3 H
R136(1)	WRP4	D2	60a	XE103(2)	R227(1)	WRP3	D5	60a	XE54(2)	R168(1)	WRP2	C4	60a	CHK TO P D10 H	R129(1)	WRP8	C2	60a	WRP8 CLK FREE A H
R11(1)	WRP9	B6	60a	XE14(15)	R120(1)	WRP2	D3	60a	XE61(15)	R176(1)	WRP2	B4	60a	CHK TO P D11 H	R135(1)	WRP8	C2	60a	WRP8 CLK FREE B H
R6(1)	WRP4	B2	60a	XE15(2)	R119(1)	WRP2	D3	60a	XE61(2)	R100(1)	WRP2	B4	60a	CHK TO P D12 H	R100(1)	WRP8	C2	60a	WRP8 CLK FREE C H
R55(1)	WRP7	B7	60a	XE16(3)	R160(1)	WRP3	C5	60a	XE66(1)	R250(1)	WRP2	B4	60a	CHK TO P D13 H	R0(1)	WRP8	C2	60a	WRP8 CLK FREE D H
R199(1)	WRP8	C7	60a	XE17(2)	R167(1)	WRP3	B5	60a	XE66(14)	R245(1)	WRP2	A4	60a	CHK TO P D14 H	R93(1)	WRP8	C2	60a	WRP8 CLK FREE E H
R198(1)	WRP8	C4	60a	XE2(13)	R164(1)	WRP3	B5	60a	XE66(15)	R256(1)	WRP3	D3	60a	CHK TO P D15 H	R290(1)	WRP8	C2	60a	WRP8 CLK FREE F H
R3(1)	WRP4	A6	60a	XE20(3)	R165(1)	WRP3	C5	60a	XE66(2)	R206(1)	WRP2	A6	60a	CHK TO P D20 H	R144(1)	WRP8	A2	60a	-WRP8 PT LPBK EN H
R140(1)	WRP4	A7	60a	XE20(7)	R121(1)	WRP2	C3	60a	XE73(15)	R200(1)	WRP2	A6	60a	CHK TO P D21 H	R50(1)	WRP8	D7	60a	WRP8 S0US TO P D00 H
R5(1)	WRP4	B3	60a	XE21(2)	R122(1)	WRP2	C3	60a	XE73(2)	R216(1)	WRP3	C6	60a	CHK TO P D22 H	R96(1)	WRP8	D6	60a	-WRP8 S0US TO P D00 H
R91(1)	WRP4	B7	60a	XE21(9)	R170(1)	WRP3	C3	60a	XE70(1)	R219(1)	WRP3	C6	60a	CHK TO P D23 H	R97(1)	WRP8	C7	60a	WRP8 S0US TO P D01 H
R4(1)	WRP7	A5	60a	XE22(2)	R179(1)	WRP3	B3	60a	XE70(14)	R230(1)	WRP3	B6	60a	CHK TO P D24 H	R277(1)	WRP8	C7	60a	WRP8 S0US TO P D02 H
R2(1)	WRP8	C7	60a	XE22(9)	R174(1)	WRP3	B3	60a	XE70(15)	R224(1)	WRP3	B6	60a	CHK TO P D25 H	R276(1)	WRP8	B7	60a	WRP8 S0US TO P D03 H
R103(1)	WRP4	B3	60a	XE23(3)	R175(1)	WRP3	C3	60a	XE70(2)	R229(1)	WRP3	B6	60a	CHK TO P D26 H	R275(1)	WRP8	D5	60a	WRP8 S0US TO P D04 H
R105(1)	WRP4	A4	60a	XE23(4)	R130(1)	WRP2	A3	60a	XE04(15)	R241(1)	WRP3	B3	60a	CHK TO P D27 H	R03(1)	WRP8	C5	60a	WRP8 S0US TO P D05 H
R146(1)	WRP2	C6	60a	XE25(1)	R126(1)	WRP2	B3	60a	XE04(2)	R244(1)	WRP3	C3	60a	CHK TO P D28 H	R234(1)	WRP8	C5	60a	WRP8 S0US TO P D06 H
R150(1)	WRP2	B6	60a	XE25(14)	R124(1)	WRP2	B3	60a	XE05(15)	R246(1)	WRP3	B3	60a	CHK TO P D29 H	R161(1)	WRP8	B5	60a	WRP8 S0US TO P D07 H
R149(1)	WRP2	C6	60a	XE25(15)	R123(1)	WRP2	B3	60a	XE05(2)	R236(1)	WRP3	B3	60a	CHK TO P D30 H	R156(1)	WRP8	B7	60a	WRP8 S0US TO P D08 H
R147(1)	WRP2	C6	60a	XE25(2)	R104(1)	WRP4	B3	60a	XE04(14)	R252(1)	WRP3	D3	60a	CHK TO P D31 H	R171(1)	WRP8	B7	60a	WRP8 S0US TO P D09 H
R90(1)	WRP4	B7	60a	XE3(11)	R102(1)	WRP3	D3	60a	XE06(1)	R250(1)	WRP3	C3	60a	CHK TO P D32 H	R166(1)	WRP8	A7	60a	WRP8 S0US TO P D10 H
R00(1)	WRP4	B7	60a	XE3(12)	R107(1)	WRP3	C3	60a	XE06(14)	R254(1)	WRP4	D7	60a	CHK TO P D33 H	R177(1)	WRP8	A7	60a	WRP8 S0US TO P D11 H
R09(1)	WRP4	B7	60a	XE3(13)	R104(1)	WRP3	C3	60a	XE06(15)	R259(1)	WRP4	D7	60a	CHK TO P D34 H	R170(1)	WRP8	B5	60a	WRP8 S0US TO P D12 H
R210(1)	WRP2	B6	60a	XE30(1)	R105(1)	WRP3	D3	60a	XE00(2)	R191(1)	WRP4	B3	60a	CHK TO P D35 H	R249(1)	WRP8	B5	60a	WRP8 S0US TO P D13 H
R213(1)	WRP2	A6	60a	XE30(14)	R47(1)	WRP0	D2	60a	XE95(16)	R94(1)	WRP4	D3	60a	-CTL3 WR DATA MOV T2 H	R243(1)	WRP8	A5	60a	WRP8 S0US TO P D14 H
R214(1)	WRP2	A6	60a	XE30(15)	R106(1)	WRP4	D7	60a	XE06(1)	R209(1)	WRP4	D5	60a	CTL6 DATA DISABLE H	R257(1)	WRP8	A5	60a	WRP8 S0US TO P D15 H
R211(1)	WRP2	B6	60a	XE30(2)	R102(1)	WRP4	D7	60a	XE06(14)	R151(1)	WRP3	B7	60a	-CTL6 P BUF LOAD H	R262(1)	WRP1	D5	60a	WRP1 S0US TO P D16 H
R270(1)	WRP8	B6	60a	XE31(1)	R109(1)	WRP4	D7	60a	XE06(15)	R200(1)	WRP4	C5	60a	CTL6 PHS DATA H	R255(1)	WRP1	C5	60a	WRP1 S0US TO P D17 H
R269(1)	WRP8	B6	60a	XE31(2)	R190(1)	WRP4	D7	60a	XE06(2)	R196(1)	WRP8	C6	60a	CTL6 SUB RAN ADR 0 H	R200(1)	WRP1	C5	60a	WRP1 S0US TO P D18 H
R13(1)	WRP9	B5	60a	XE32(15)	R200(1)	WRP8	B7	60a	ADT1 P ADR 33 H	R197(1)	WRP8	C6	60a	CTL6 SUB RAN ADR 1 H	R203(1)	WRP1	C5	60a	WRP1 S0US TO P D19 H
R127(1)	WRP7	A7	60a	XE34(6)	R40(1)	WRP3	A7	60a	ADT4 P BUF NEN RD SEL H	R95(1)	WRP4	B5	60a	-CTL8 S DIAG T0 H	R207(1)	WRP1	B5	60a	WRP1 S0US TO P D20 H
R9(1)	WRP9	B3	60a	XE40(15)	R155(1)	WRP8	C3	60a	ADT6 CLK FREE 00-020- H	R92(1)	WRP4	B5	60a	-CTL8 S DIAG T1 H	R203(1)	WRP1	B5	60a	WRP1 S0US TO P D21 H
R10(1)	WRP9	C4	60a	XE41(15)	R204(1)	WRP2	C6	60a	CHK TO P D00 H	R102(1)	WRP4	C3	60a	-CTL8 S DIAG T2 H	R220(1)	WRP1	B5	60a	WRP1 S0US TO P D22 H
R12(1)	WRP9	B7	60a	XE45(15)	R205(1)	WRP2	C6	60a	CHK TO P D01 H	R260(1)	WRP4	D7	60a	SYN6 CHK TO P D16 H	R223(1)	WRP1	B5	60a	WRP1 S0US TO P D23 H
R14(1)	WRP9	B4	60a	XE46(15)	R205(1)	WRP2	B6	60a	CHK TO P D02 H	R261(1)	WRP4	D7	60a	SYN6 CHK TO P D17 H	R235(1)	WRP1	A5	60a	WRP1 S0US TO P D24 H
R260(1)	WRP8	D6	60a	XE49(1)	R201(1)	WRP2	B6	60a	CHK TO P D03 H	R201(1)	WRP2	B6	60a	SYN6 CHK TO P D18 H	R231(1)	WRP1	D3	60a	WRP1 S0US TO P D25 H
R267(1)	WRP8	C6	60a	XE49(15)	R221(1)	WRP3	D6	60a	CHK TO P D04 H	R202(1)	WRP2	B6	60a	SYN6 CHK TO P D19 H	R233(1)	WRP1	D3	60a	WRP1 S0US TO P D26 H
R266(1)	WRP8	C6	60a	XE49(2)	R222(1)	WRP3	D6	60a	CHK TO P D05 H	R253(1)	WRP3	C3	60a	SYN6 CHK TO P DATA PAR H	R239(1)	WRP1	D3	60a	WRP1 S0US TO P D27 H
R63(1)	WRP3	A6	60a	XE5(2)	R232(1)	WRP3	C6	60a	CHK TO P D06 H	R217(1)	WRP8	D7	60a	SYN7 P BLK ADR 0 H	R240(1)	WRP1	C3	60a	WRP1 S0US TO P D28 H
R225(1)	WRP3	D5	60a	XE54(1)	R162(1)	WRP2	D4	60a	CHK TO P D07 H	R210(1)	WRP8	C7	60a	SYN7 P BLK ADR 1 H	R237(1)	WRP1	C3	60a	WRP1 S0US TO P D29 H
R226(1)	WRP3	C5	60a	XE54(14)	R157(1)	WRP2	D4	60a	CHK TO P D08 H	R212(1)	WRP8	C7	60a	SYN7 P BLK ADR 2 H	R230(1)	WRP1	C3	60a	WRP1 S0US TO P D30 H

NOTE:

1. ALL TERMINATORS HAVE PIN TWO CONNECTED TO -2.0V AND ARE 5% 1/4WATT UNLESS OTHERWISE SPECIFIED
2. ENTRIES ARE SORTED BY SIGNAL NAME
3. % INDICATES OUTPUT OF DIP LOC AND (<) INDICATES PIN NUMBER

THIS DRAWING AND SPECIFICATIONS HEREBY ARE THE PROPERTY OF DIGITAL EQUIPMENT CORPORATION AND SHALL NOT BE REPRODUCED OR COPIED IN WHOLE OR IN PART OR THE BASIS FOR THE MANUFACTURE OR SALE OF ITEMS WITHOUT WRITTEN PERMISSION OF DIGITAL EQUIPMENT CORPORATION.	REVISIONS CHK CHANGE NO. REV		<b>digital</b> DRN. <i>G. Smith</i> DATE <i>07-20-78</i> ENR. <i>W. Chen</i> DATE <i>07/28/78</i> TITLE: WRITE PATH TERMINATORS	
EQ3741 DRN 4.654	07-20-78	27.3m 74 SHEET 1 OF 2	SIZE CODE D CS	NUMBER 18574-0-RES
FIRST USED ON OPTION/MODEL: MF20			REV.	

8

7

6

5

4

3

2

53W-0-4260U 53 0 3003 3015

1

RESISTOR LOC(PIN)	DRUM	SHOWN ON REF	VALUE	TERMINATES SIGNAL
R133(1)	WRP1	B3	60a	WRP1 SBUS TO P D31 H
R134(1)	WRP1	B3	60a	WRP1 SBUS TO P D32 H
R07(1)	WRP1	B3	60a	WRP1 SBUS TO P D33 H
R131(1)	WRP1	B3	60a	WRP1 SBUS TO P D34 H
R132(1)	WRP1	A3	60a	WRP1 SBUS TO P D35 H
R248(1)	WRP1	A3	60a	WRP1 SBUS TO P DATA PAR H
R71(1)	WRP2	C5	60a	WRP2 P BUF D00 H
R74(1)	WRP2	C5	60a	WRP2 P BUF D01 H
R73(1)	WRP2	B5	60a	WRP2 P BUF D02 H
R70(1)	WRP2	B5	60a	WRP2 P BUF D03 H
R195(1)	WRP2	D2	60a	WRP2 P BUF D07 H
R141(1)	WRP2	D2	60a	WRP2 P BUF D08 H
R140(1)	WRP2	C2	60a	WRP2 P BUF D09 H
R142(1)	WRP2	C2	60a	WRP2 P BUF D10 H
R264(1)	WRP2	B2	60a	WRP2 P BUF D11 H
R137(1)	WRP2	B2	60a	WRP2 P BUF D12 H
R265(1)	WRP2	B2	60a	WRP2 P BUF D13 H
R139(1)	WRP2	B2	60a	WRP2 P BUF D14 H
R204(1)	WRP2	C5	60a	WRP2 P BUF D10 H
R206(1)	WRP2	B5	60a	WRP2 P BUF D19 H
R90(1)	WRP2	A5	60a	WRP2 P BUF D20 H
R107(1)	WRP2	A5	60a	WRP2 P BUF D21 H
R154(1)	WRP3	D5	60a	WRP3 P BUF D04 H
R111(1)	WRP3	D5	60a	WRP3 P BUF D05 H
R112(1)	WRP3	C5	60a	WRP3 P BUF D06 H
R130(1)	WRP3	D2	60a	WRP3 P BUF D15 H
R106(1)	WRP3	C5	60a	WRP3 P BUF D22 H
R109(1)	WRP3	C5	60a	WRP3 P BUF D23 H
R59(1)	WRP3	C5	60a	WRP3 P BUF D24 H
R69(1)	WRP3	B5	60a	WRP3 P BUF D25 H
R49(1)	WRP3	B5	60a	WRP3 P BUF D26 H
R62(1)	WRP3	B2	60a	WRP3 P BUF D27 H
R60(1)	WRP3	C2	60a	WRP3 P BUF D28 H
R65(1)	WRP3	C2	60a	WRP3 P BUF D29 H
R66(1)	WRP3	B2	60a	WRP3 P BUF D30 H
R202(1)	WRP3	D2	60a	WRP3 P BUF D31 H
R67(1)	WRP3	C2	60a	WRP3 P BUF D32 H
R41(1)	WRP3	C2	60a	WRP3 P BUF DATA PAR H
R125(1)	WRP3	B7	60a	-WRP3 P BUF LOAD A H
R193(1)	WRP3	B7	60a	-WRP3 P BUF LOAD B H

RESISTOR LOC(PIN)	DRUM	SHOWN ON REF	VALUE	TERMINATES SIGNAL
R251(1)	WRP3	A6	60a	WRP3 P BUF RD SEL H
R194(1)	WRP3	A6	60a	-WRP3 P BUF RD SEL H
R207(1)	WRP4	D4	60a	WRP4 DATA DISABLE A H
R291(1)	WRP4	D4	60a	WRP4 DATA DISABLE B H
R292(1)	WRP4	D4	60a	WRP4 DATA DISABLE C H
R295(1)	WRP4	C4	60a	WRP4 DATA DISABLE D H
R215(1)	WRP4	B4	60a	WRP4 DIAG CYCLE H
R61(1)	WRP4	B4	60a	-WRP4 DIAG CYCLE H
R7(1)	WRP4	B5	60a	WRP4 DIAG T0 H
R51(1)	WRP4	B5	60a	-WRP4 DIAG T0 H
R64(1)	WRP4	B5	60a	WRP4 DIAG T1 H
R120(1)	WRP4	B5	60a	-WRP4 DIAG T1 H
R24(1)	WRP4	B2	60a	WRP4 HLD CHCODE H
R145(1)	WRP4	B5	60a	WRP4 MR RESET A H
R153(1)	WRP4	D6	60a	WRP4 P BUF D16 H
R152(1)	WRP4	D6	60a	WRP4 P BUF D17 H
R100(1)	WRP4	D6	60a	WRP4 P BUF D33 H
R110(1)	WRP4	D6	60a	WRP4 P BUF D34 H
R113(1)	WRP4	D2	60a	WRP4 P BUF D35 H
R143(1)	WRP4	A7	60a	-WRP4 S DIAG PT LPBK H
R54(1)	WRP5	C4	60a	-WRP5 P TO ECC D15 H
R60(1)	WRP5	B6	60a	-WRP5 P TO ECC D25 H
R25(1)	WRP6	B1	60a	WRP6 ECC CHECK 16 H
R26(1)	WRP6	C1	60a	WRP6 ECC CHECK 32 H
R43(1)	WRP6	D7	60a	WRP6 ECC GEN 1 H
R46(1)	WRP6	D2	60a	WRP6 ECC GEN 16 H
R44(1)	WRP6	D6	60a	WRP6 ECC GEN 2 H
R42(1)	WRP6	D1	60a	WRP6 ECC GEN 32 H
R23(1)	WRP6	D5	60a	WRP6 ECC GEN 4 H
R45(1)	WRP6	D4	60a	WRP6 ECC GEN 8 H
R19(1)	WRP6	C7	60a	WRP6 ECC GEN PAR H
R72(1)	WRP6	B7	60a	WRP6 ECC PAR 000,01,03 H
R27(1)	WRP6	B7	60a	WRP6 ECC PAR 000,02,03 H
R01(1)	WRP6	B7	60a	WRP6 ECC PAR 000-02 H
R32(1)	WRP6	B7	60a	WRP6 ECC PAR 001-03 H
R02(1)	WRP6	B6	60a	WRP6 ECC PAR 004,05,07,10 H
R75(1)	WRP6	B6	60a	WRP6 ECC PAR 004,06,00,10 H
R20(1)	WRP6	B6	60a	WRP6 ECC PAR 005,06,09,10 H
R79(1)	WRP6	B6	60a	WRP6 ECC PAR 006,00,09 H
R33(1)	WRP6	B6	60a	WRP6 ECC PAR 007-10 H

RESISTOR LOC(PIN)	DRUM	SHOWN ON REF	VALUE	TERMINATES SIGNAL
R37(1)	WRP6	B5	60a	WRP6 ECC PAR 011,12,14,17 H
R77(1)	WRP6	B5	60a	WRP6 ECC PAR 011,13,15,17 H
R29(1)	WRP6	B5	60a	WRP6 ECC PAR 012,13,16,17 H
R30(1)	WRP6	B5	60a	WRP6 ECC PAR 013,15,16 H
R34(1)	WRP6	B5	60a	WRP6 ECC PAR 014-17 H
R40(1)	WRP6	B3	60a	WRP6 ECC PAR 010,21,23,24 H
R39(1)	WRP6	B3	60a	WRP6 ECC PAR 019,20,22,25 H
R76(1)	WRP6	B3	60a	WRP6 ECC PAR 019,21,23,25 H
R31(1)	WRP6	B3	60a	WRP6 ECC PAR 020,21,24,25 H
R36(1)	WRP6	B3	60a	WRP6 ECC PAR 022-25 H
R04(1)	WRP6	B2	60a	WRP6 ECC PAR 026,27,29,32 H
R70(1)	WRP6	B2	60a	WRP6 ECC PAR 026,28,30,32 H
R30(1)	WRP6	B2	60a	WRP6 ECC PAR 027,20,31,32 H
R05(1)	WRP6	B2	60a	WRP6 ECC PAR 020,30,31 H
R35(1)	WRP6	B2	60a	WRP6 ECC PAR 029-32 H
R99(1)	WRP6	C4	60a	WRP6 HI
R163(1)	WRP7	D6	60a	WRP7 DIAG 0 H
R159(1)	WRP7	D6	60a	WRP7 DIAG 1 H
R173(1)	WRP7	D5	60a	WRP7 DIAG 2 H
R169(1)	WRP7	D5	60a	WRP7 DIAG 3 H
R103(1)	WRP7	D3	60a	WRP7 DIAG 4 H
R101(1)	WRP7	D3	60a	WRP7 DIAG 5 H
R242(1)	WRP7	D2	60a	WRP7 DIAG 6 H
R247(1)	WRP7	D2	60a	WRP7 DIAG 7 H
R53(1)	WRP7	A1	60a	WRP7 DIAG SIX 4 H
R50(1)	WRP7	A1	60a	WRP7 DIAG SIX 5 H
R52(1)	WRP7	A1	60a	WRP7 DIAG SIX 6 H
R101(1)	WRP7	A1	60a	WRP7 DIAG SIX 7 H
R17(1)	WRP7	C5	60a	WRP7 ECC COMP 1 H
R10(1)	WRP7	C7	60a	WRP7 ECC COMP 16 H
R21(1)	WRP7	C5	60a	WRP7 ECC COMP 2 H
R06(1)	WRP7	C7	60a	WRP7 ECC COMP 32 H
R16(1)	WRP7	C7	60a	WRP7 ECC COMP 4 H
R15(1)	WRP7	C7	60a	WRP7 ECC COMP 0 H
R115(1)	WRP7	C5	60a	WRP7 ECC COMP EVEN H
R20(1)	WRP7	C5	60a	WRP7 ECC COMP PAR H
R117(1)	WRP7	B7	60a	WRP7 ECC DIAG SEL 1 H
R110(1)	WRP7	A7	60a	WRP7 ECC DIAG SEL 2 H
R00(1)	WRP7	B7	60a	-WRP7 ECC LOAD COMP BIT H
R100(1)	WRP7	B3	60a	WRP7 FCH 01 H

RESISTOR LOC(PIN)	DRUM	SHOWN ON REF	VALUE	TERMINATES SIGNAL
R56(1)	WRP7	A3	60a	WRP7 FCH 06 H
R57(1)	WRP7	A3	60a	WRP7 FCH 07 H
R150(1)	WRP7	A6	60a	WRP7 P BUF SEL 2 H
R114(1)	WRP7	B1	60a	WRP7 SPARE HELD H
R22(1)	WRP7	A4	60a	WRP7 MR DIAG SEL H
R1(1)	WRP8	B3	60a	-WRP8 DIAG T0+1 H
R116(1)	WRP8	C1	60a	WRP8 ECC SUB RAN PAR H

NOTE:

- 1. ALL TERMINATORS HAVE PIN TWO CONNECTED TO -2.0V AND ARE 5% 1/4WATT UNLESS OTHERWISE SPECIFIED
- 2. ENTRIES ARE SORTED BY SIGNAL NAME
- 3. % INDICATES OUTPUT OF DIP LOC AND ( ) INDICATES PIN NUMBER

THIS DRAWING AND SPECIFICATIONS HEREOF ARE THE PROPERTY OF DIGITAL EQUIPMENT CORPORATION AND SHALL NOT BE REPRODUCED OR COPIED OR USED IN WHOLE OR IN PART AS THE BASIS FOR THE MANUFACTURE OR SALE OF ITEMS WITHOUT WRITTEN PERMISSION. COPYRIGHT © 1976, DIGITAL EQUIPMENT CORPORATION.

REVISIONS		
CHK	CHANGE NO.	REV

<b>digital</b>	DRN. <u>G. Smith</u>	DATE <u>02-20-78</u>	ENG. <u>J. Chen</u>	DATE <u>02/20/78</u>	TITLE: <b>WRITE PATH TERMINATORS</b>
	CHK'D BY <u>J. Kucera</u>	DATE <u>02-20-78</u>	DATE <u>02-20-78</u>	SHEET <u>2</u> OF <u>2</u>	
FIRST USED ON OPTION/MODEL: <u>MF20</u>			NEXT HIGHER ASSEMBLY: <u>D-DD-M8574-0</u>		
SIZE	CODE	NUMBER	REV.		
D	CS	M8574-0-RES			

8

7

6

5

4

3

2

1

DRAWING NUMBER	PAGE	PART NO.	DESCRIPTION	REVISIONS
			FILE: ORIGINAL LAYOUT	
			ECO NUMBER	
			MODULE REVISION	A
E-UA-M8575-0-0	4		SYNDROME	A
D-UA-M8575-0-0	1		SYNDROME	A
K-PL-M8575-0-DBP	2		PARTS LIST	A
D-CS-M8575-0-SYN0	1		BIT SUB DECODER	-
D-CS-M8575-0-SYN1	1		BIT SUB DATA	-
D-CS-M8575-0-SYN2	1		BIT SUB, ECC BITS	-
D-CS-M8575-0-SYN3	1		GENERATOR	-
D-CS-M8575-0-SYN4	1		CALCULATOR	-
D-CS-M8575-0-SYN5	1		CORRECTION DECODE	-
D-CS-M8575-0-SYN6	1		DATA CORRECTION	-
D-CS-M8575-0-SYN7	1		PORT ADDRESS	-
D-CS-M8575-0-SYN8	1		DIAG SELECTION	-
D-CS-M8575-0-SYN9	1		DIAG MIXER	-
D-CS-M8575-0-SYNA	1		POWER CONTROL	-
D-CS-M8575-0-SYNB	1		POWER. GND. CAPS.	-
D-CS-M8575-0-SYNC	1		POWER. GND. CAPS.	-
D-CS-M8575-0-RES	3		TERMINATORS	-
E-MD-5012899-0-0	5		DRILL & ETCH DRAWING	B
		5012899	ETCH CIRCUIT BOARD	C
K-PC-M8575-0-DBC	-		P.C. DESIGN DATA BASE	A
P00-M8575-00	-		PROCESS SHEET (REF ONLY)	-

NOTES:

THIS DRAWING AND SPECIFICATIONS, HEREIN, ARE THE PROPERTY OF DIGITAL EQUIPMENT CORPORATION AND SHALL NOT BE REPRODUCED OR COPIED OR USED IN WHOLE OR IN PART AS THE BASIS FOR THE MANUFACTURE OR SALE OF ITEMS WITHOUT WRITTEN PERMISSION. COPYRIGHT © 1970, DIGITAL EQUIPMENT CORPORATION.

REVISIONS		
CHK	CHANGE NO.	REV

digital

DRN *P. Luciani*

DATE 20-20-78

ENG. *J. Ann*

DATE 24-04-78

BOARD LOCATION: 5200C

DATE 22-04-78

SHEET 1 OF 1

TITLE: SYNDROME

PROD. *W. J. Early 28 Jun 78*

DSK10975DD.T2PL4.6651 120-JUN-78 15:35 FIRST USED ON OPTION MODEL: MF20

NEXT HIGHER ASSEMBLY: NONE

2

SIZE CODE D DD

88575-0

REV. 1

MR

REV. NUMBER 88575-0

A

COMPONENT SIDE VIEW

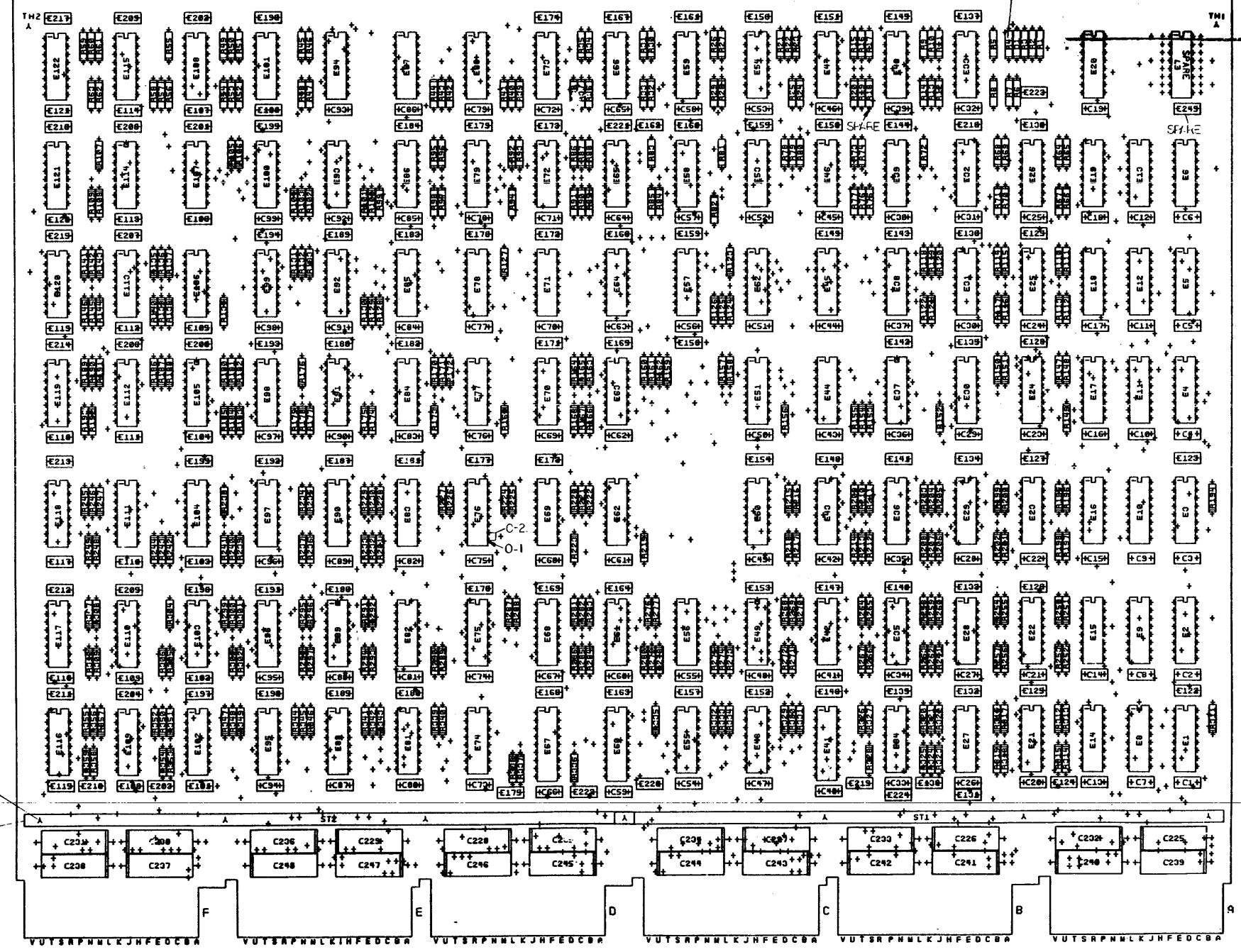

DATE	2/27/74
DESIGNED BY	W. J. ...
ENGINEER	...
PROJ. NO.	...
REV. NO.	...
REV. DATE	...
REV. BY	...
REV. REASON	...
REV. NO.	...
REV. DATE	...
REV. BY	...
REV. REASON	...
REV. NO.	...
REV. DATE	...
REV. BY	...
REV. REASON	...

DESIGNED BY	W. J. ...
ENGINEER	...
PROJ. NO.	...
REV. NO.	...
REV. DATE	...
REV. BY	...
REV. REASON	...
REV. NO.	...
REV. DATE	...
REV. BY	...
REV. REASON	...

DATE	2/27/74
DESIGNED BY	W. J. ...
ENGINEER	...
PROJ. NO.	...
REV. NO.	...
REV. DATE	...
REV. BY	...
REV. REASON	...
REV. NO.	...
REV. DATE	...
REV. BY	...
REV. REASON	...

DATE	2/27/74
DESIGNED BY	W. J. ...
ENGINEER	...
PROJ. NO.	...
REV. NO.	...
REV. DATE	...
REV. BY	...
REV. REASON	...
REV. NO.	...
REV. DATE	...
REV. BY	...
REV. REASON	...

NOTES: 1. CAUTION: FOR REMOVAL OF THIS BOARD FROM THE SYSTEM, THE BOARD MUST BE DISCONNECTED FROM ALL POWER SUPPLIES AND GROUNDING POINTS.  
 2. ALL COMPONENTS MUST BE IDENTIFIED BY PART NUMBER AND VALUE.  
 3. ALL COMPONENTS MUST BE IDENTIFIED BY PART NUMBER AND VALUE.  
 4. ALL COMPONENTS MUST BE IDENTIFIED BY PART NUMBER AND VALUE.

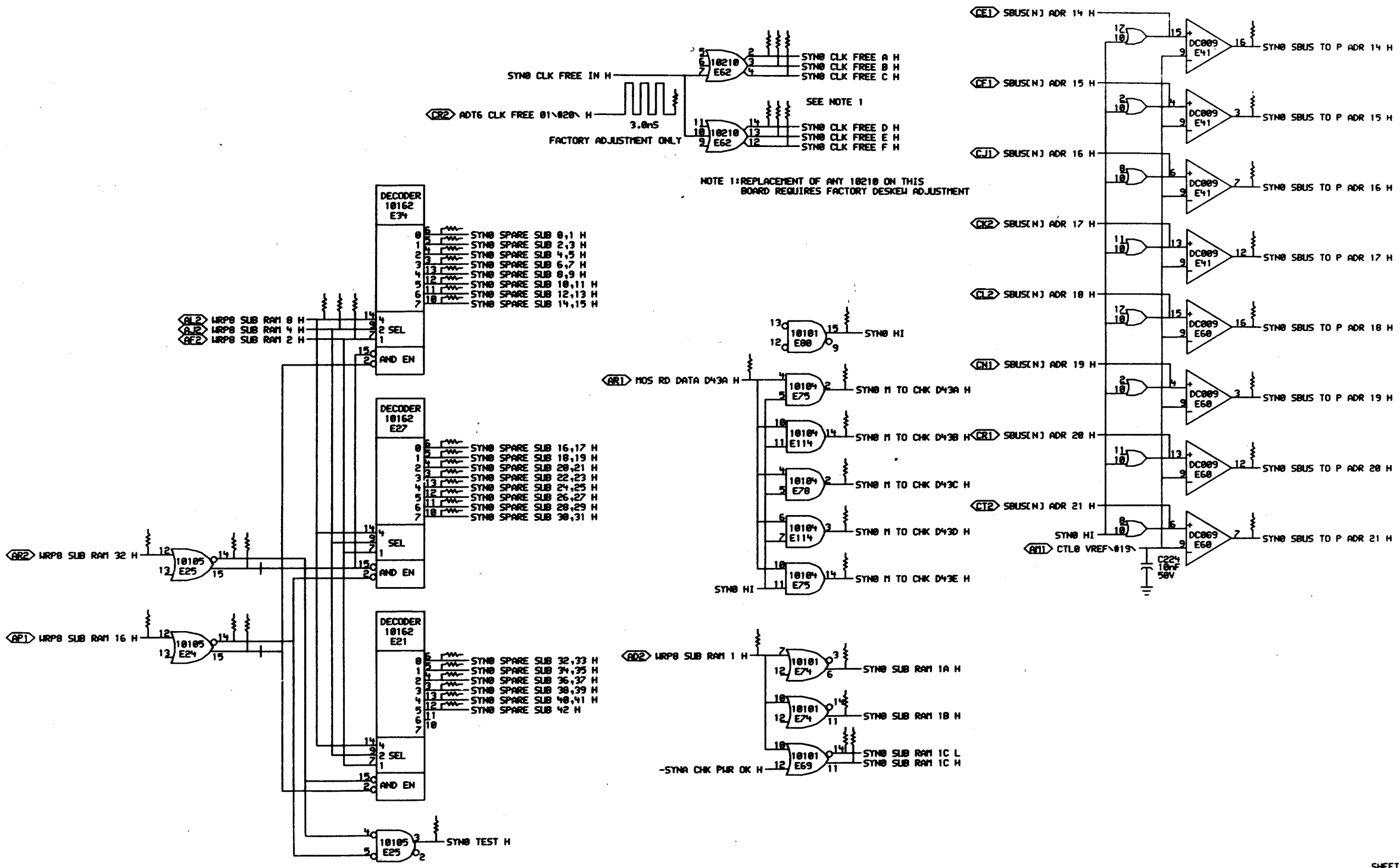

SHEET 1 OF 13

REV. 1  
 NUMBER 108575-0-SYN0  
 CODE CS  
 SIZE D  
 B  
 A

THIS DRAWING AND SPECIFICATIONS ARE THE PROPERTY OF DIGITAL EQUIPMENT CORPORATION AND SHALL NOT BE REPRODUCED OR COPIED OR USED IN WHOLE OR IN PART AS THE BASIS FOR THE MANUFACTURE OR SALE OF ITEMS WITHOUT WRITTEN PERMISSION. COPYRIGHT © 1974 DIGITAL EQUIPMENT CORPORATION.

REVISIONS	CHK	CHANGE NO.	REV

DATE	ENG.	DATE	TITLE
12-28-79	DJ Chin	2/6-78	SYNDROME BIT SUB DECODER
11-1-78			

**digital** ORN *Lucas* DATE 12-28-79 ENG. DJ Chin DATE 2/6-78 TITLE: SYNDROME BIT SUB DECODER

108575-0-SYN0 DRUID: JAY-78 1312 NEXT HIGHER ASSEMBLY: SIZE CODE NUMBER REV. D CS 108575-0-SYN0 ME 1

FIRST USED ON OPTION/MODEL: MF20 D-DD-M8575-0

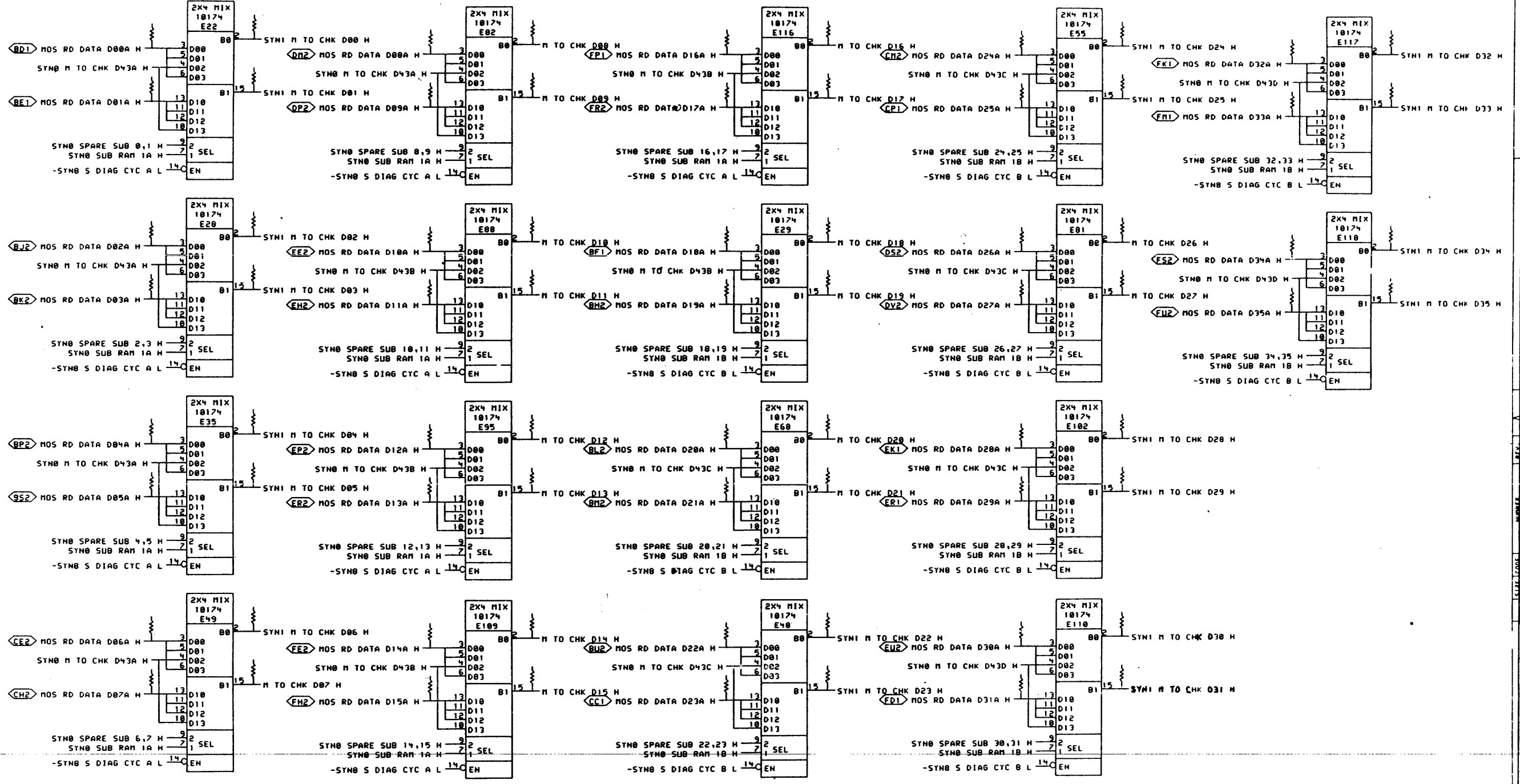

"THIS DRAWING AND SPECIFICATIONS, HEREIN, ARE THE PROPERTY OF DIGITAL EQUIPMENT CORPORATION AND SHALL NOT BE REPRODUCED OR COPIED OR USED IN WHOLE OR IN PART AS THE BASIS FOR THE MANUFACTURE OR SALE OF ITEMS WITHOUT WRITTEN PERMISSION. COPYRIGHT © 1978, DIGITAL EQUIPMENT CORPORATION"

REVISIONS		
CHK	CHANGE NO.	REV

	DRN <i>Plucan</i>	DATE 15-000-78	ENG. <i>clm</i>	DATE 24-000-78	TITLE: SYNDROME BIT SUB DATA
	CHK: 17	DATE 28-APR-78	BOARD LOCATION: 3A8B6	DATE 22-APR-78	REV. 1
SYN18-DRAW 4,665/1		28-APR-78 08:22	NEXT HIGHER ASSEMBLY: D-DD-M8575-0	SIZE CODE D CS	NUMBER M8575-0-SYN1
FIRST USED ON OPTION/MODEL: MF20					REV. 1

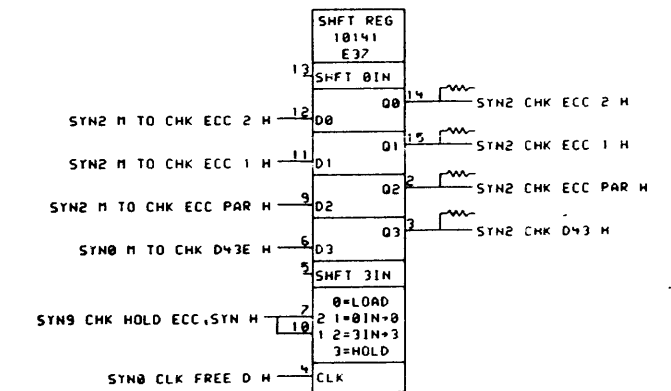
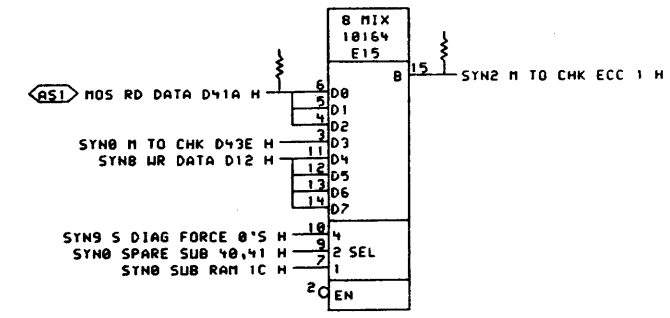
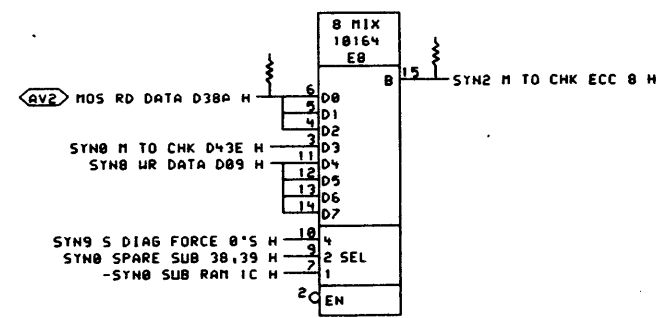
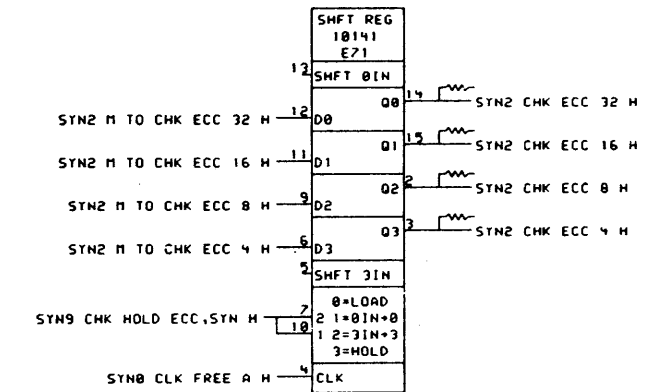
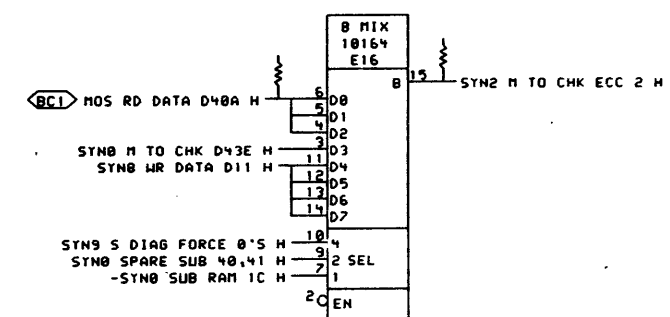
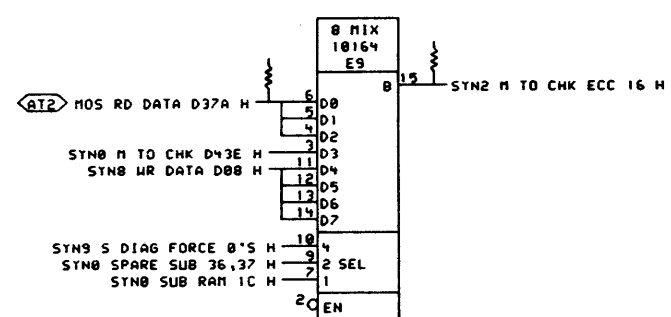
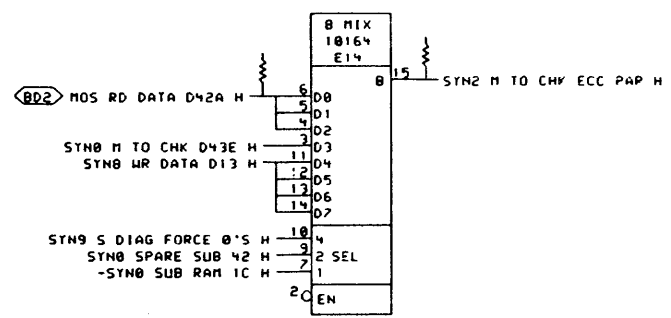
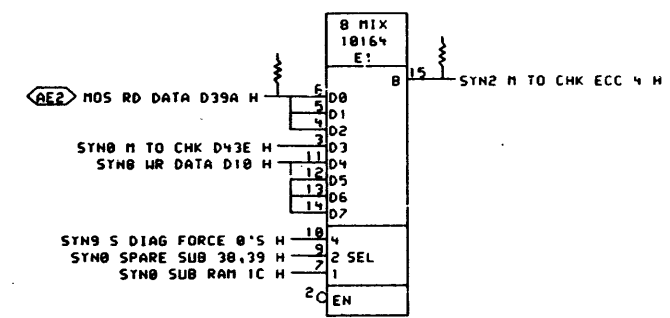
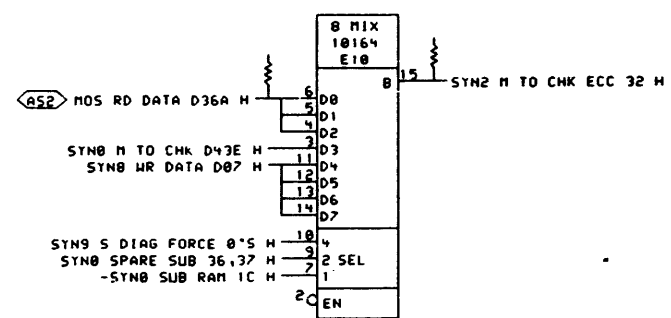

"THIS DRAWING AND SPECIFICATIONS, HEREIN, ARE THE PROPERTY OF DIGITAL EQUIPMENT CORPORATION AND SHALL NOT BE REPRODUCED OR COPIED OR USED IN WHOLE OR IN PART AS THE BASIS FOR THE MANUFACTURE OR SALE OF ITEMS WITHOUT WRITTEN PERMISSION."  
 COPYRIGHT © 1978, DIGITAL EQUIPMENT CORPORATION

REVISIONS		
CHK	CHANGE NO.	REV

DRN	DATE	ENG.	DATE	TITLE:
CHK	19-APR-78	me	19-APR-78	SYNDROME BIT SUB ECC BITS

digital

SYN2B.DRW 4,665 128-APR-78 08:22 NEXT HIGHER ASSEMBLY: D CS M8575-0-SYN2

FIRST USED ON OPTION MODEL: MF20

DATE: 19-APR-78

RCARD LOCATION: 5AF06

SIZE CODE: D CS

NUMBER: M8575-0-SYN2

REV.:

REV. NUMBER SIZE CODE

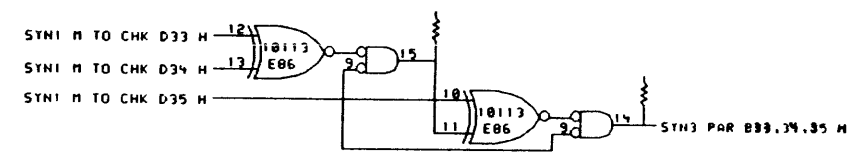
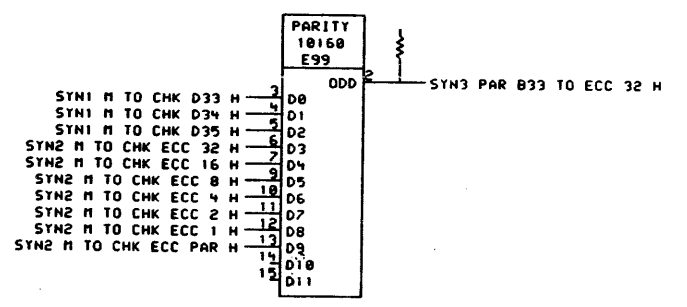
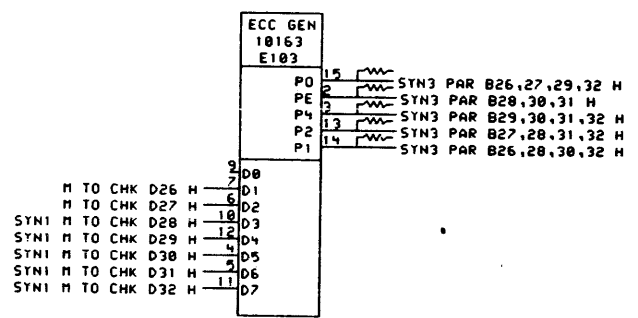
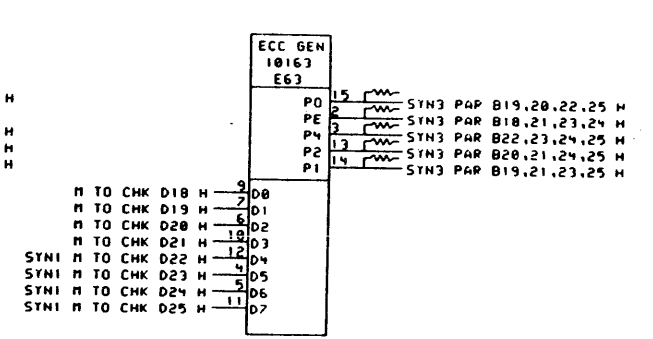
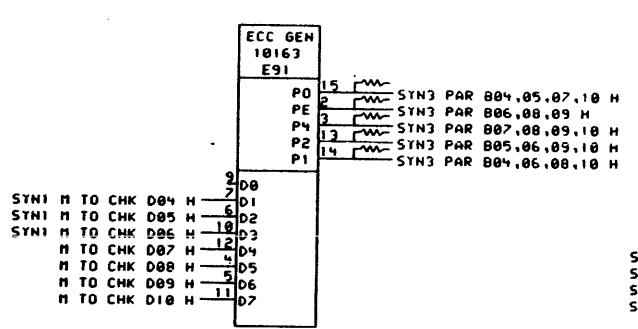
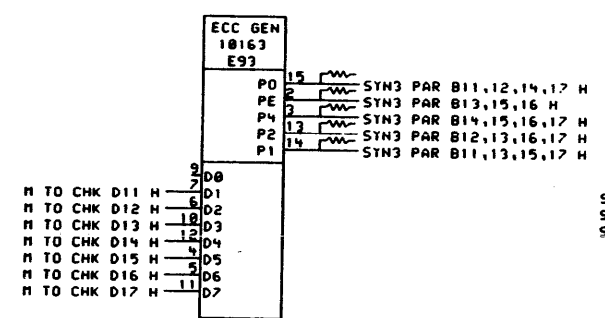
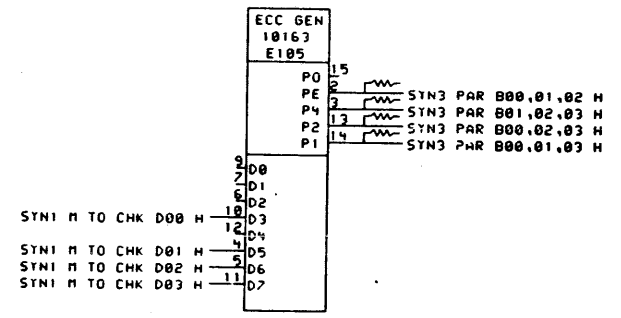

THIS DRAWING AND SPECIFICATIONS, HEREIN, ARE THE PROPERTY OF DIGITAL EQUIPMENT CORPORATION AND SHALL NOT BE REPRODUCED OR COPIED OR USED IN WHOLE OR IN PART AS THE BASIS FOR THE MANUFACTURE OR SALE OF ITEMS WITHOUT WRITTEN PERMISSION.  
COPYRIGHT © 1978, DIGITAL EQUIPMENT CORPORATION

REVISIONS		
CHK	CHANGE NO.	REV

<b>digital</b>	DRN <i>Deviser</i>	DATE 19-APR-78	ENG. <i>Chen</i>	DATE 28-APR-78	TITLE: <b>SYNDROME GENERATOR</b>
	CHK'D <i>Deviser</i>	DATE 28-APR-78	BOARD LOCATION: 5AF06	SHEET 1 OF 1	NUMBER
FIRST USED ON OPTION/MODEL: SYN3B, DRAW 4.665J MF20		NEXT HIGHER ASSEMBLY: D-DD-M8F75-0		SIZE CODE: D	CS.M8575-0-SYN3

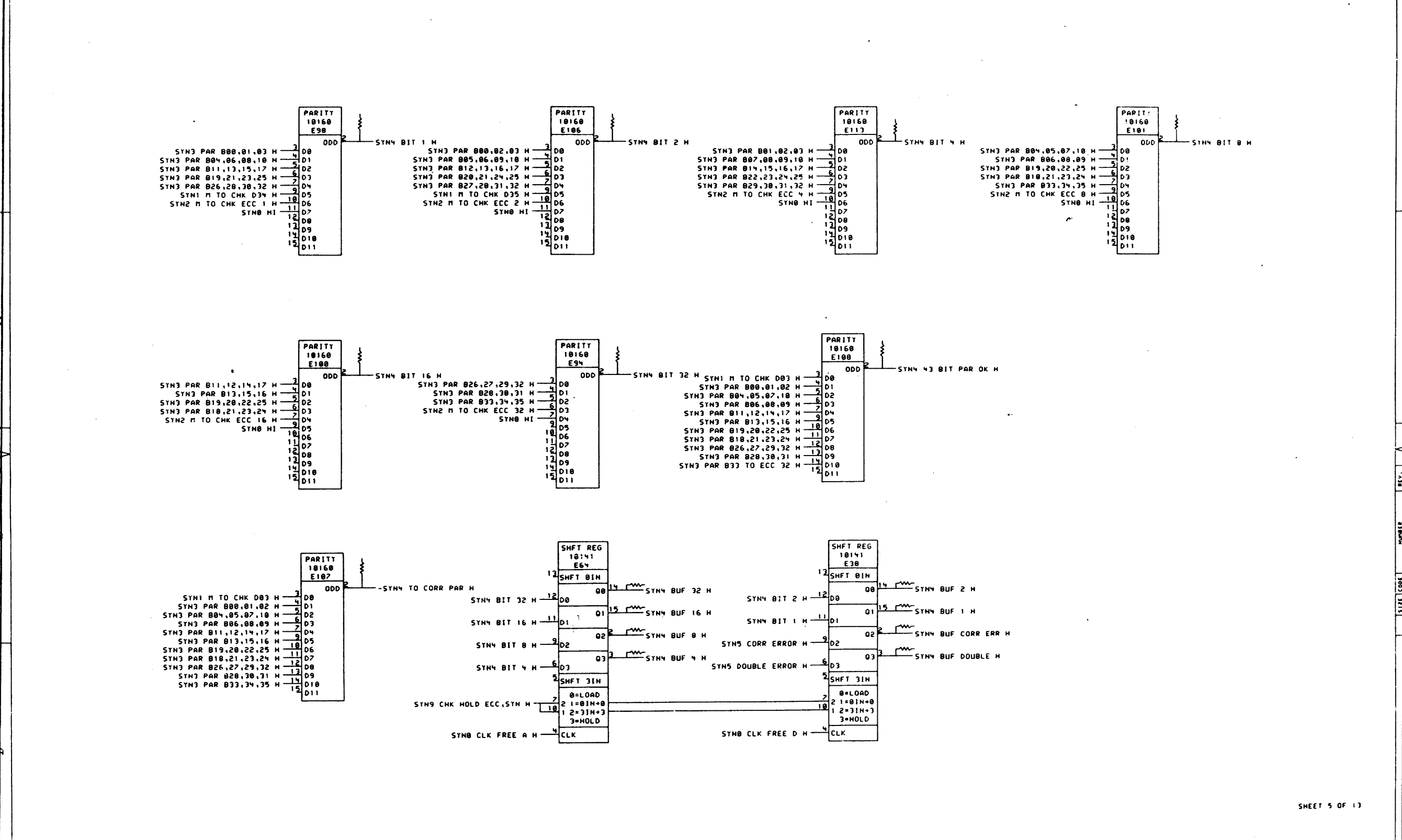

SHEET 5 OF 13

"THIS DRAWING AND SPECIFICATIONS, HEREIN, ARE THE PROPERTY OF DIGITAL EQUIPMENT CORPORATION AND SHALL NOT BE REPRODUCED OR COPIED OR USED IN WHOLE OR IN PART AS THE BASIS FOR THE MANUFACTURE OR SALE OF ITEMS WITHOUT WRITTEN PERMISSION. COPYRIGHT © 1970, DIGITAL EQUIPMENT CORPORATION"

REVISIONS		
CHK	CHANG. NO.	REV.

DATE	ENG.	DATE	TITLE:
18-APR-70	Lucas	23-APR-70	SYNDROME CALCULATOR
DATE	BOARD LOCATION:	DATE	SIZE CODE
28-APR-70	5A866	28-APR-70	D CS
DATE	NEXT HIGHER ASSEMBLY:	DATE	NUMBER
28-APR-70	D-DD-M8575-0	28-APR-70	M8575-0-SYN4
DATE	FIRST USED ON OPTION/MODEL:	DATE	REV.
28-APR-70	MF20	28-APR-70	ME

digital DRN Lucas  
 SYN4B.DRW(4,565)  
 FIRST USED ON OPTION/MODEL: MF20

me

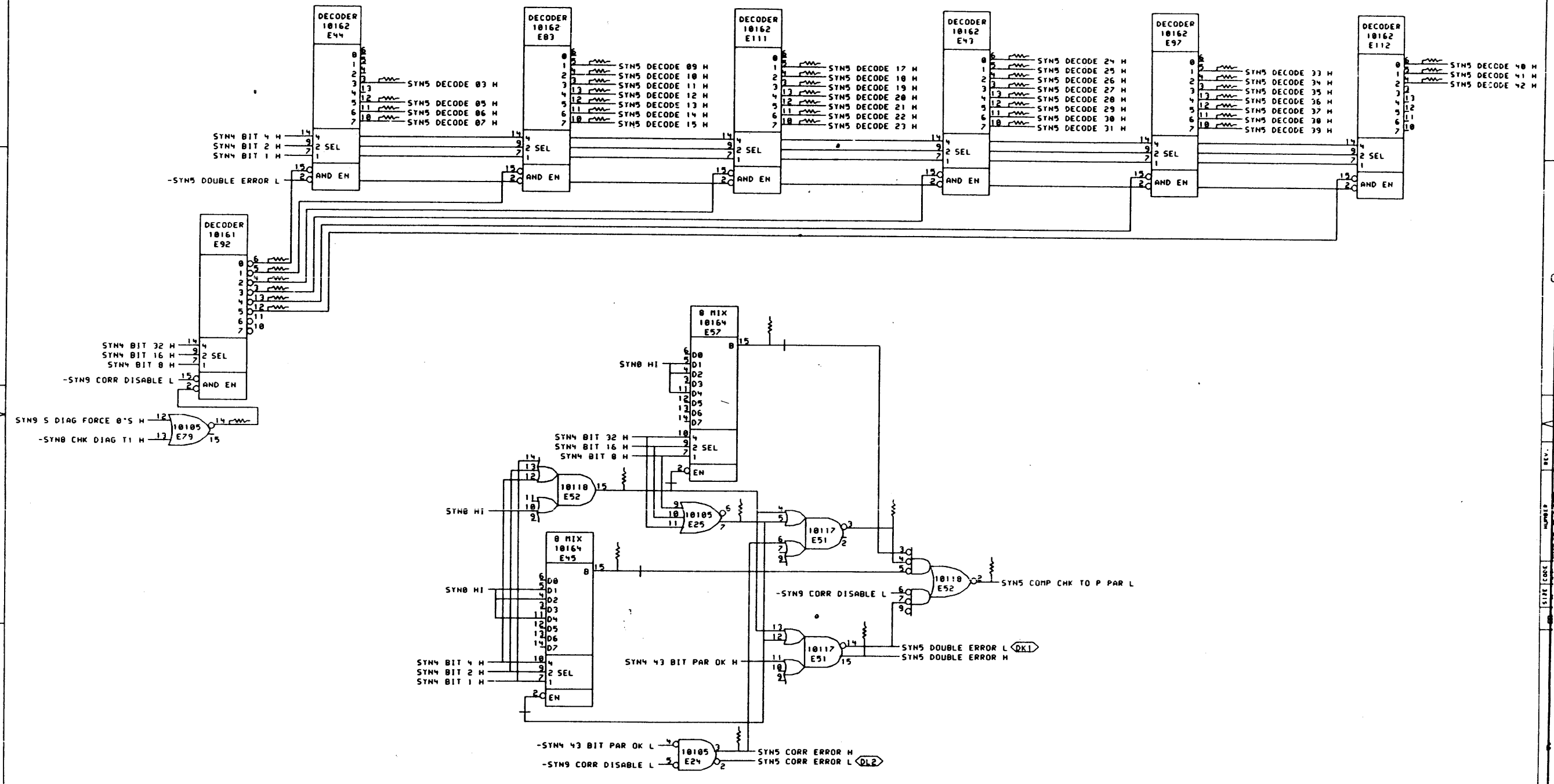

SHEET 6 OF 13

THIS DRAWING AND SPECIFICATIONS, HEREIN, ARE THE PROPERTY OF DIGITAL EQUIPMENT CORPORATION AND SHALL NOT BE REPRODUCED OR COPIED OR USED IN WHOLE OR IN PART AS THE BASIS FOR THE MANUFACTURE OR SALE OF ITEMS WITHOUT WRITTEN PERMISSION.  
 COPYRIGHT © 1970, DIGITAL EQUIPMENT CORPORATION

REVISIONS	
CHK	CHANGE NO. REV

digital	DRN	DATE	ENG.	DATE	TITLE:
	CHP	19-APR-70			SYNDROME CORRECTION DECODE
SIN5B.DRW(4,665)		20-APR-70 08:24	NEXT HIGHER ASSEMBLY:	SIZE	CODE
FIRST USED ON OPTION/MODEL: MF20		D-DD-M8575-0		D	CS M8575-0-SYN5

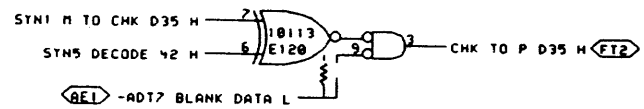
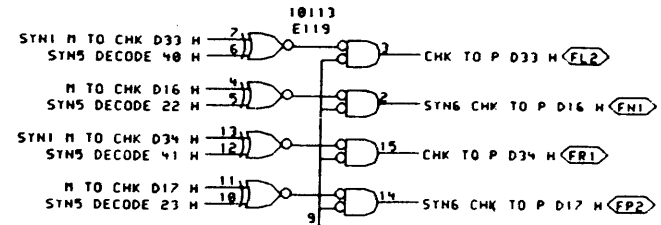
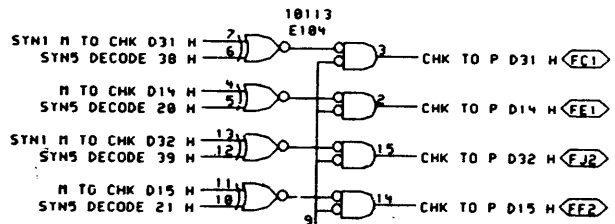
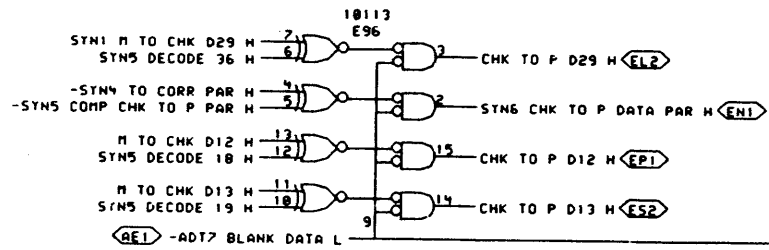
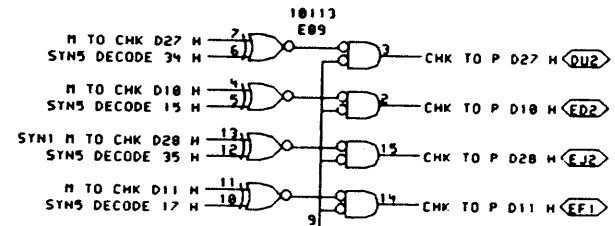
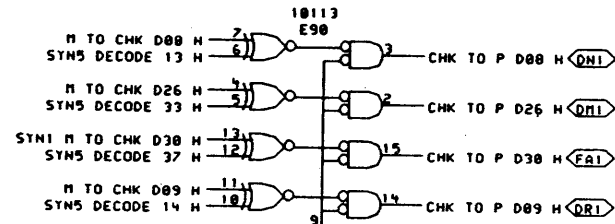
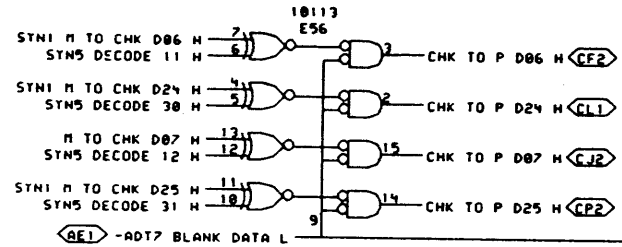
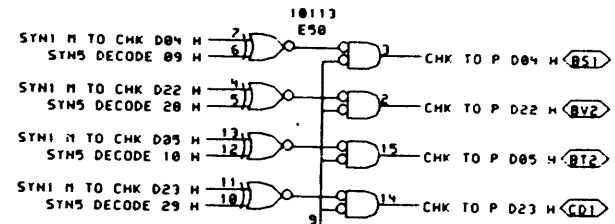
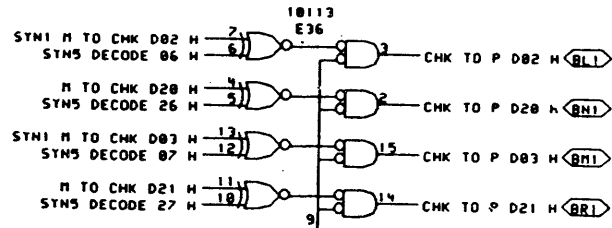
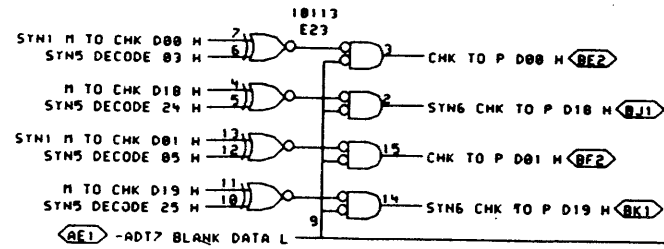

THIS DRAWING AND SPECIFICATIONS, HEREIN, ARE THE PROPERTY OF DIGITAL EQUIPMENT CORPORATION AND SHALL NOT BE REPRODUCED OR COPIED OR USED IN WHOLE OR IN PART AS THE BASIS FOR THE MANUFACTURE OR SALE OF ITEMS WITHOUT WRITTEN PERMISSION.  
COPYRIGHT © 1970, DIGITAL EQUIPMENT CORPORATION

REVISIONS	
CHK	CHANGE NO. / REV

digital  
SYN60.DRM(4,665)  
FIRST USED ON OPTION/MODEL: MF20

DRN: *P. Lucum*  
DATE: 19-APR-78  
DATE: 20-APR-78 08:24  
BOARD LOCATION: 7AF06  
SHEET: 1  
NEXT HIGHER ASSEMBLY: D-DD-M8575-0

TITLE: SYNDROME DATA CORRECTION  
SIZE CODE: D, CS  
NUMBER: M8575-0-SYN6  
REV. 1

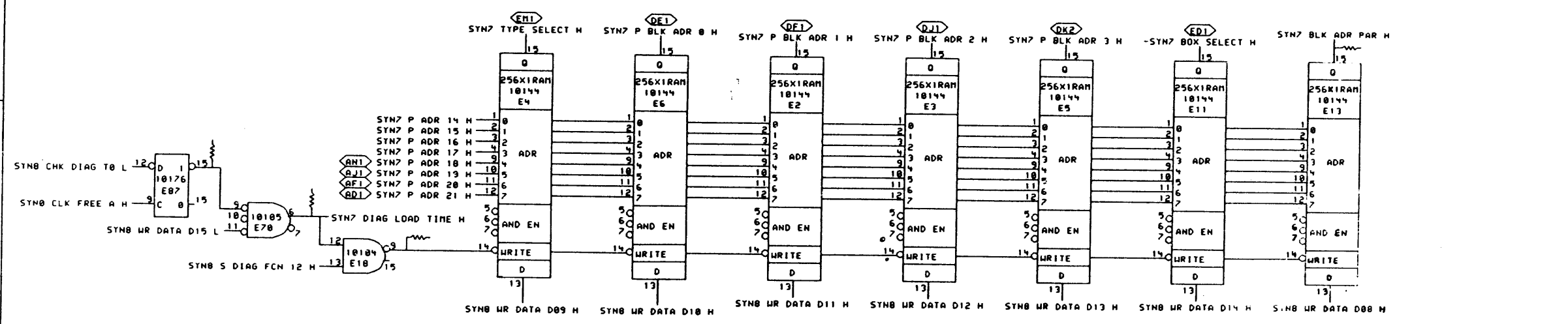
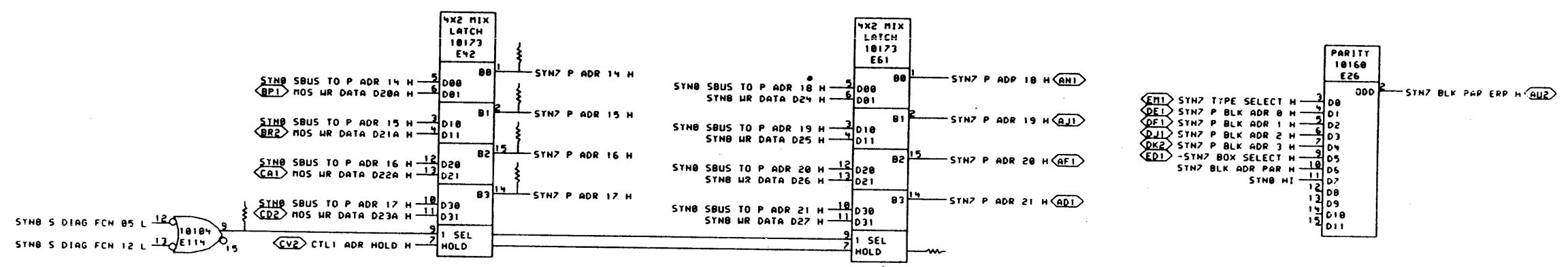
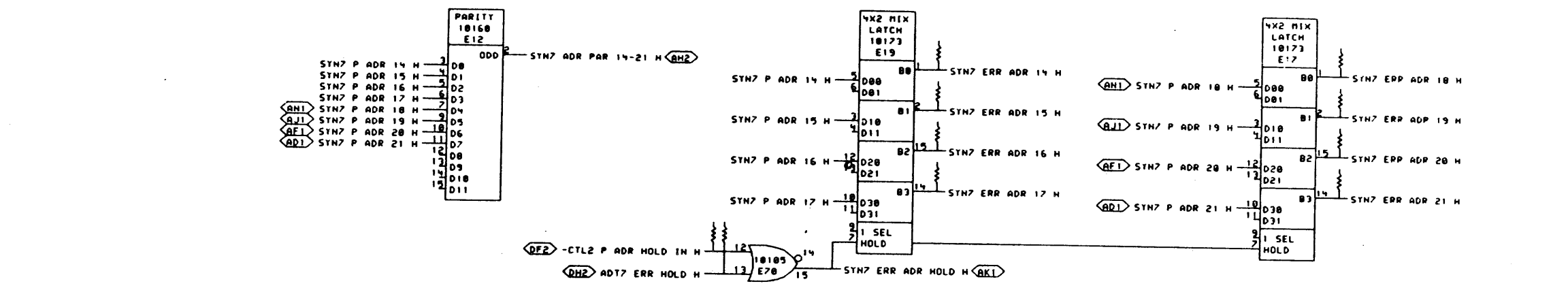

THIS DRAWING AND SPECIFICATIONS, HEREIN, ARE THE PROPERTY OF DIGITAL EQUIPMENT CORPORATION AND SHALL NOT BE REPRODUCED OR COPIED OR USED IN WHOLE OR IN PART AS THE BASIS FOR THE MANUFACTURE OR SALE OF ITEMS WITHOUT WRITTEN PERMISSION.  
 COPYRIGHT © 1978, DIGITAL EQUIPMENT CORPORATION

REVISIONS	
CHK	CHANGE NO. REV

	DRN: <i>Drucen</i>	DATE: 10-MAY-78	ENG: <i>...</i>	DATE: <i>...</i>	TITLE: SYNDROME PORT ADDRESS
	CHK: <i>...</i>	DATE: 22 JUN 1978	BOARD LOCATION: 5H06	REV: <i>...</i>	
SYN7B.DRM 4.663		10-MAY-78 13:25	NEXT HIGHER ASSEMBLY:	SIZE CODE: D	NUMBER: CS 18575-0-SYN7
FIRST USED ON OPTION/MODEL: MF20		0-DD-18575-0			REV. <i>...</i>

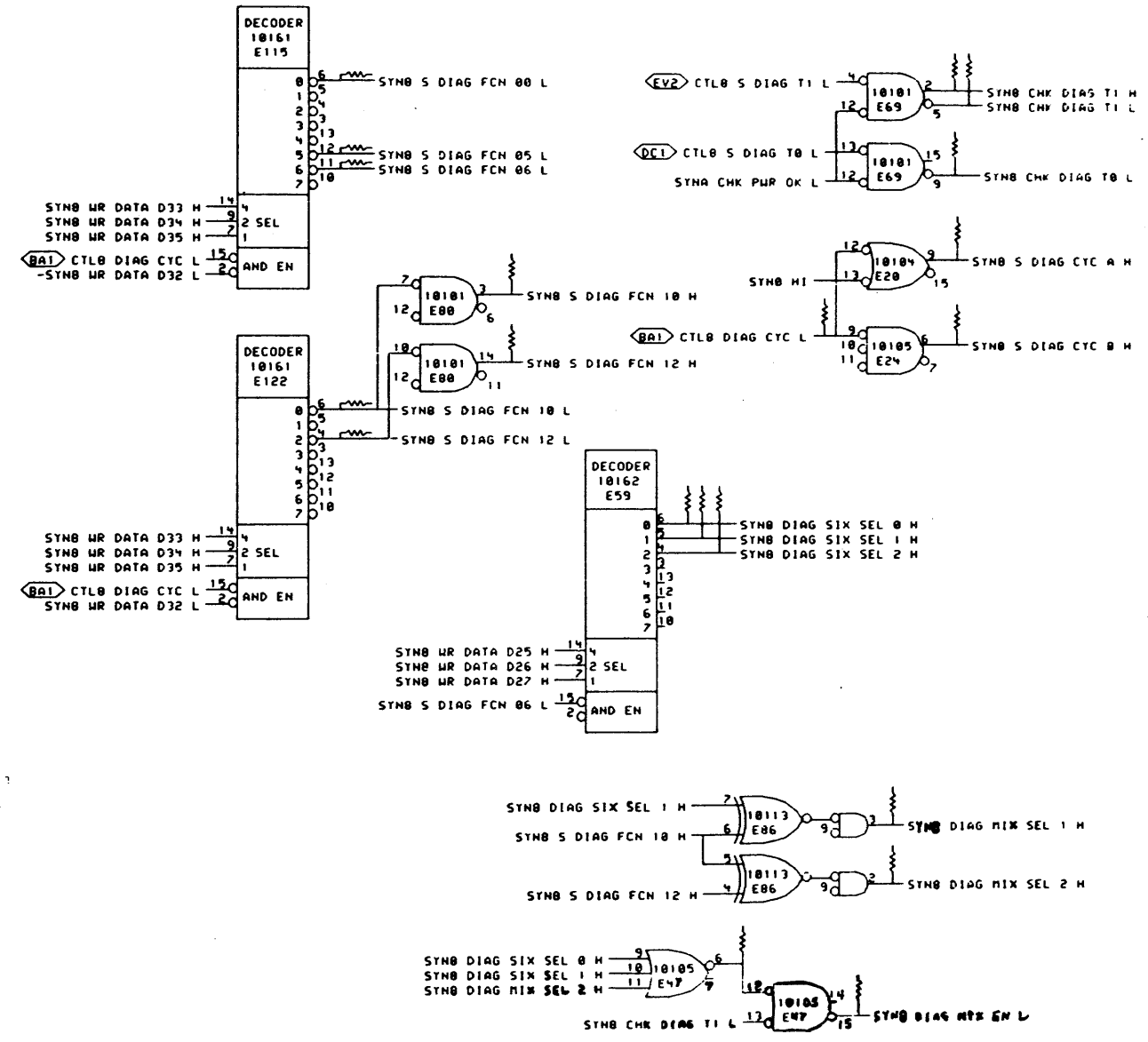
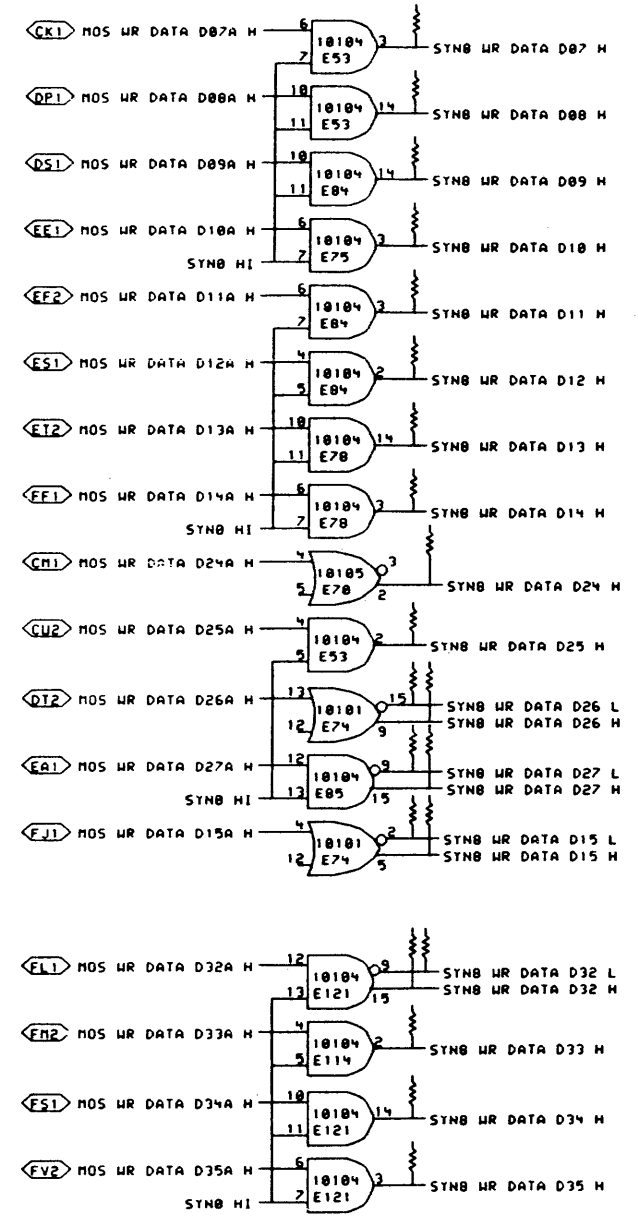

\*THIS DRAWING AND SPECIFICATIONS, HEREIN, ARE THE PROPERTY OF DIGITAL EQUIPMENT CORPORATION AND SHALL NOT BE REPRODUCED OR COPIED OR USED IN WHOLE OR IN PART AS THE BASIS FOR THE MANUFACTURE OR SALE OF ITEMS WITHOUT WRITTEN PERMISSION.  
COPYRIGHT © 1974, DIGITAL EQUIPMENT CORPORATION

REVISIONS		
CHK	CHANGE NO.	REV

digital	DRN <i>P. Lucas</i>	DATE 18-APR-78	ENG. <i>Lucas</i>	DATE <i>18-APR-78</i>	TITLE: <b>SYNDROME DIAG SELECTION</b>
CHK <i>9</i>	DATE <i>18-APR-78</i>	BOARD LOCATION: <i>9AF06</i>		REV.	
SYMB. DRAWING: <i>4, 663</i>			NEXT HIGHER ASSEMBLY:		SIZE CODE NUMBER
FIRST USED ON OPTION/MODEL: <i>MF20</i>			D-00-M8575-0		<b>D CS M8575-0-SYN8</b>

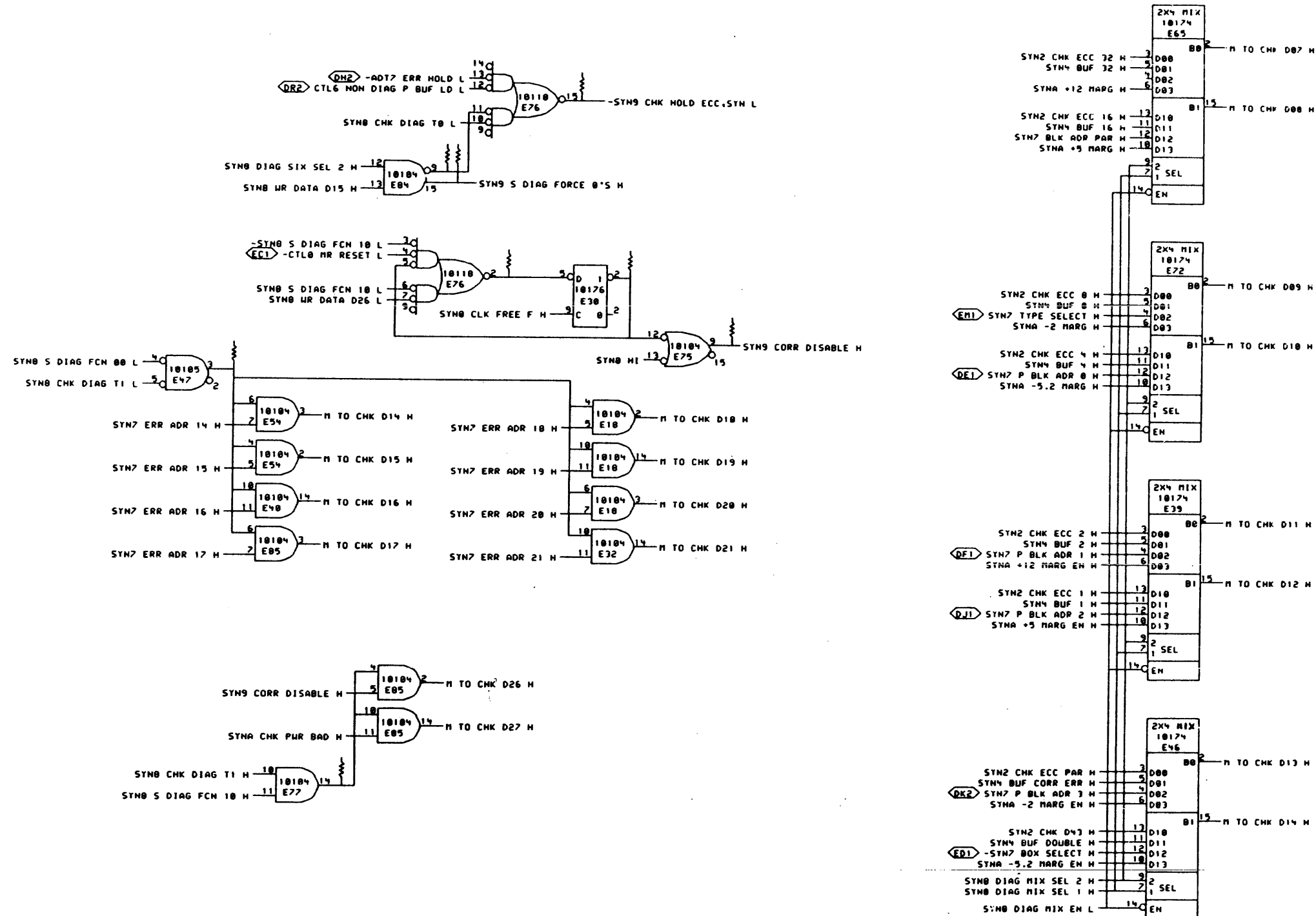

THIS DRAWING AND SPECIFICATIONS, HEREIN, ARE THE PROPERTY OF DIGITAL EQUIPMENT CORPORATION AND SHALL NOT BE REPRODUCED OR COPIED OR USED IN WHOLE OR IN PART AS THE BASIS FOR THE MANUFACTURE OR SALE OF ITEMS, WITHOUT WRITTEN PERMISSION. COPYRIGHT © 1978, DIGITAL EQUIPMENT CORPORATION.

REVISIONS	
CHK	CHANGE NO. REV

DRN	DATE	ENG.	DATE	TITLE:
CHK	DATE	BOARD LOCATION:	SAF86	SYNDROME DIAG MIXER

STN9.DRM4.663	109-JUN-78	10:46	NEXT HIGHER ASSEMBLY:
FIRST USED ON OPTION/MODEL:	MF20	D-DD-M8575-0	

SIZE	CODE	NUMBER	REV.
D	CS	M8575-0-SYN9	

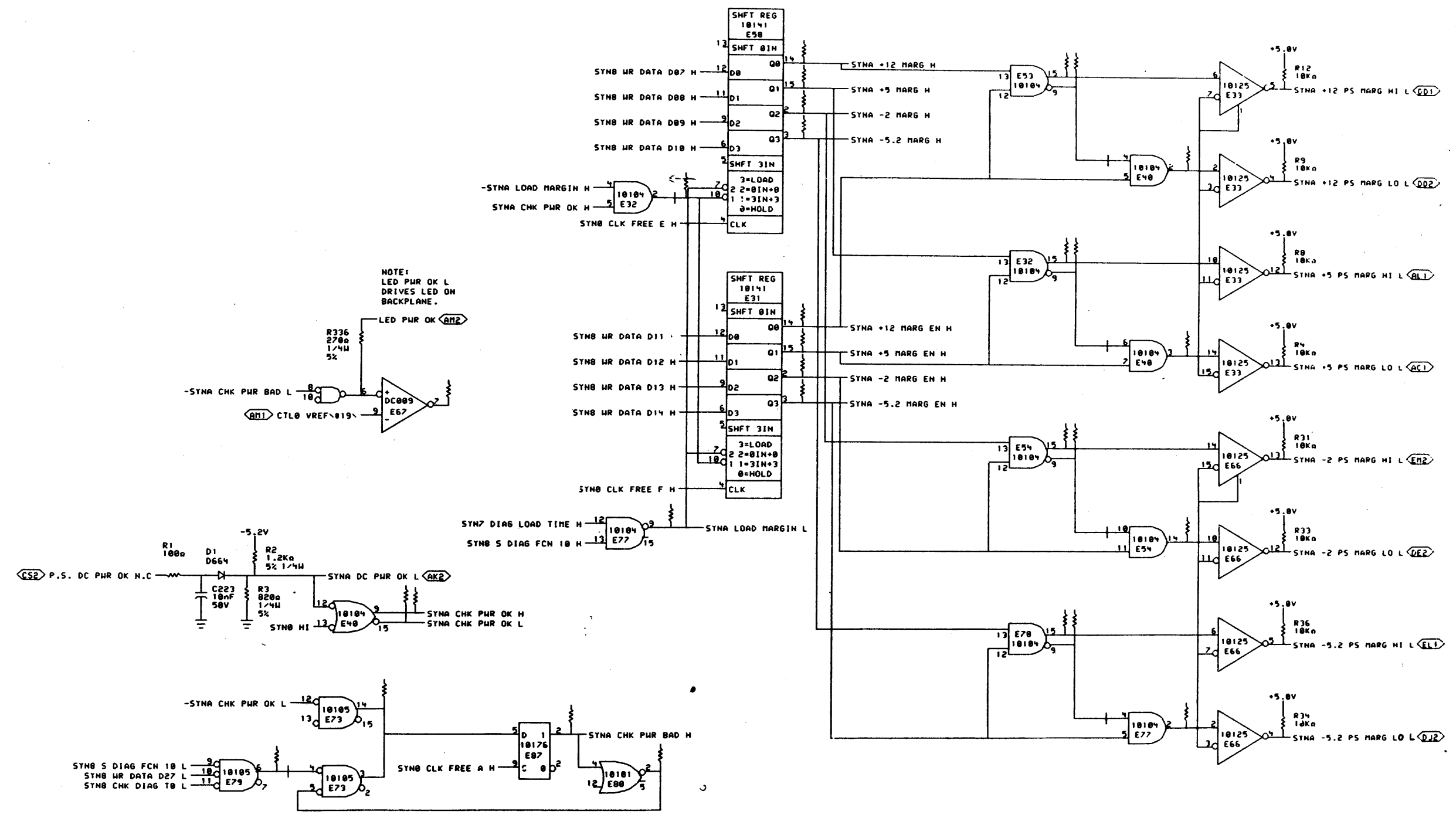

SHEET 11 OF 18

"THIS DRAWING AND SPECIFICATIONS, HEREIN, ARE THE PROPERTY OF DIGITAL EQUIPMENT CORPORATION AND SHALL NOT BE REPRODUCED OR COPIED OR USED IN WHOLE OR IN PART AS THE BASIS FOR THE MANUFACTURE OR SALE OF ITEMS WITHOUT WRITTEN PERMISSION. COPYRIGHT © 1978, DIGITAL EQUIPMENT CORPORATION"

REVISIONS		
CHK	CHANGE NO.	REV

digital	DRN	DATE	ENG.	DATE	TITLE
	CHK	19-08-78	Lucien	25-08-78	SYNDROME POWER CONTROL
SYN85.DRW(4,655)		DATE	BOARD LOCATION	SIZE	CODE
FIRST USED ON OPT:ON-MODEL		11-05-78 13:28	SAF86	D	CS
				NUMBER	REV.
				D-DD-M8575-0	1 ME

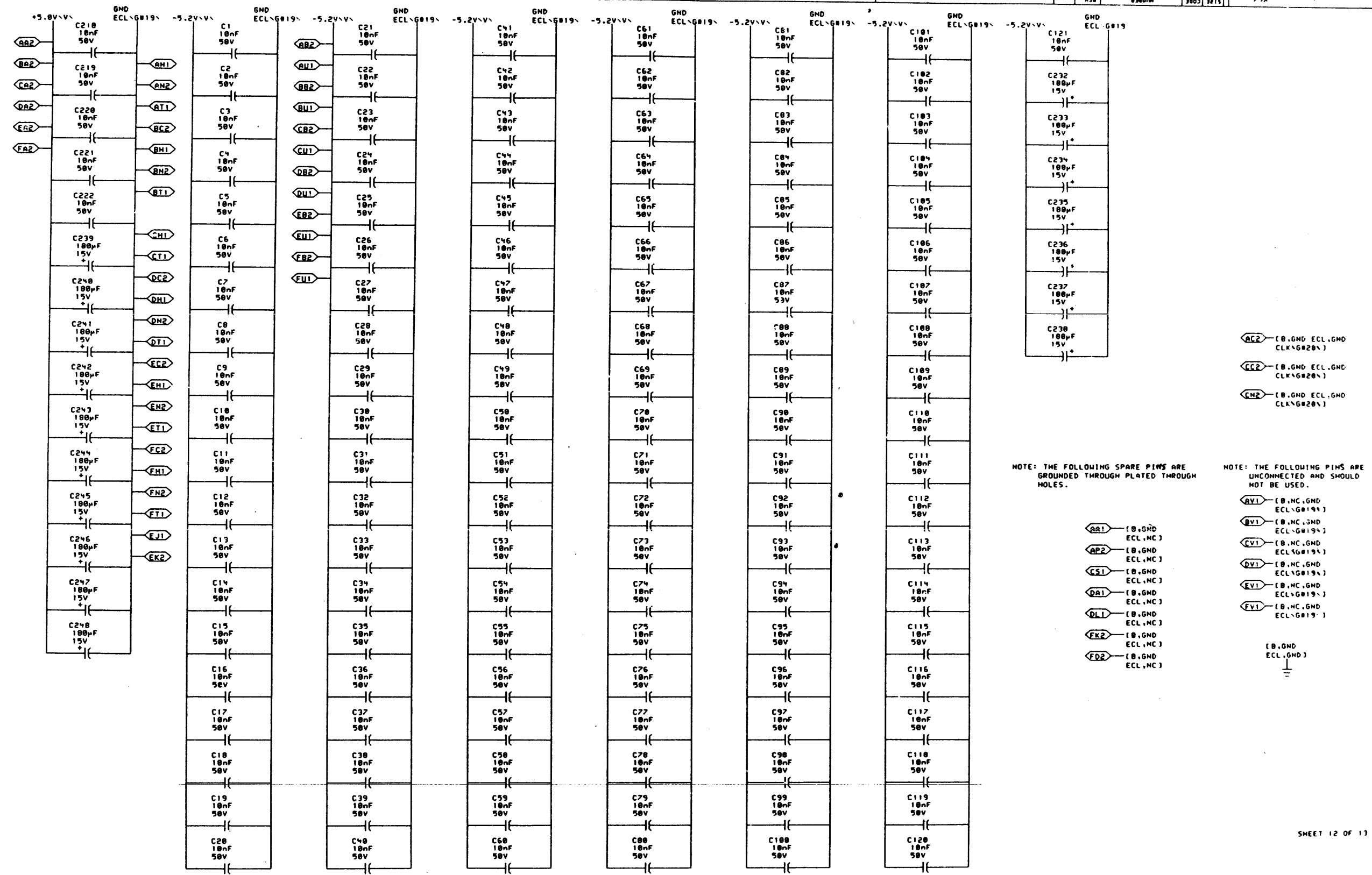

NOTE: THE FOLLOWING SPARE PINS ARE GROUNDED THROUGH PLATED THROUGH HOLES.

NOTE: THE FOLLOWING PINS ARE UNCONNECTED AND SHOULD NOT BE USED.

- AB1 (B,GND ECL,NC)
- AB2 (B,GND ECL,NC)
- CS1 (B,GND ECL,NC)
- DA1 (B,GND ECL,NC)
- DL1 (B,GND ECL,NC)
- EK2 (B,GND ECL,NC)
- FD2 (B,GND ECL,NC)
- AV1 (B,NC,GND ECL,G819)
- BV1 (B,NC,GND ECL,G819)
- CV1 (B,NC,GND ECL,G819)
- DV1 (B,NC,GND ECL,G819)
- EV1 (B,NC,GND ECL,G819)
- FV1 (B,NC,GND ECL,G819)
- (B,GND ECL,GND)

SHEET 12 OF 13

THIS DRAWING AND SPECIFICATIONS HEREBY ARE THE PROPERTY OF DIGITAL EQUIPMENT CORPORATION AND SHALL NOT BE REPRODUCED OR COPIED OR USED IN WHOLE OR IN PART AS THE BASIS FOR THE MANUFACTURE OR SALE OF ITEMS WITHOUT WRITTEN PERMISSION. COPYRIGHT © 1978. DIGITAL EQUIPMENT CORPORATION.

REVISIONS	
CHK	CHANGE NO. REV

<b>digital</b>	DRN <i>P. Lucas</i>	DATE 30-MAY-78	ENG. <i>John</i>	DATE 26-MAY-78	TITLE: SYNDROME POWER. GND. CAPS.
	CHKD <i>Lucas</i>	DATE 27-MAY-78	BOARD LOCATION: 50A96	REV. 1	
SYMB DRN 6651		30-MAY-78 13:20	NEXT HIGHER ASSEMBLY:	SIZE C008	NUMBER
FIRST USED ON OPTION/MODEL: MF20		D-DD-M8575-0		D	CS M8575-0-SYMB

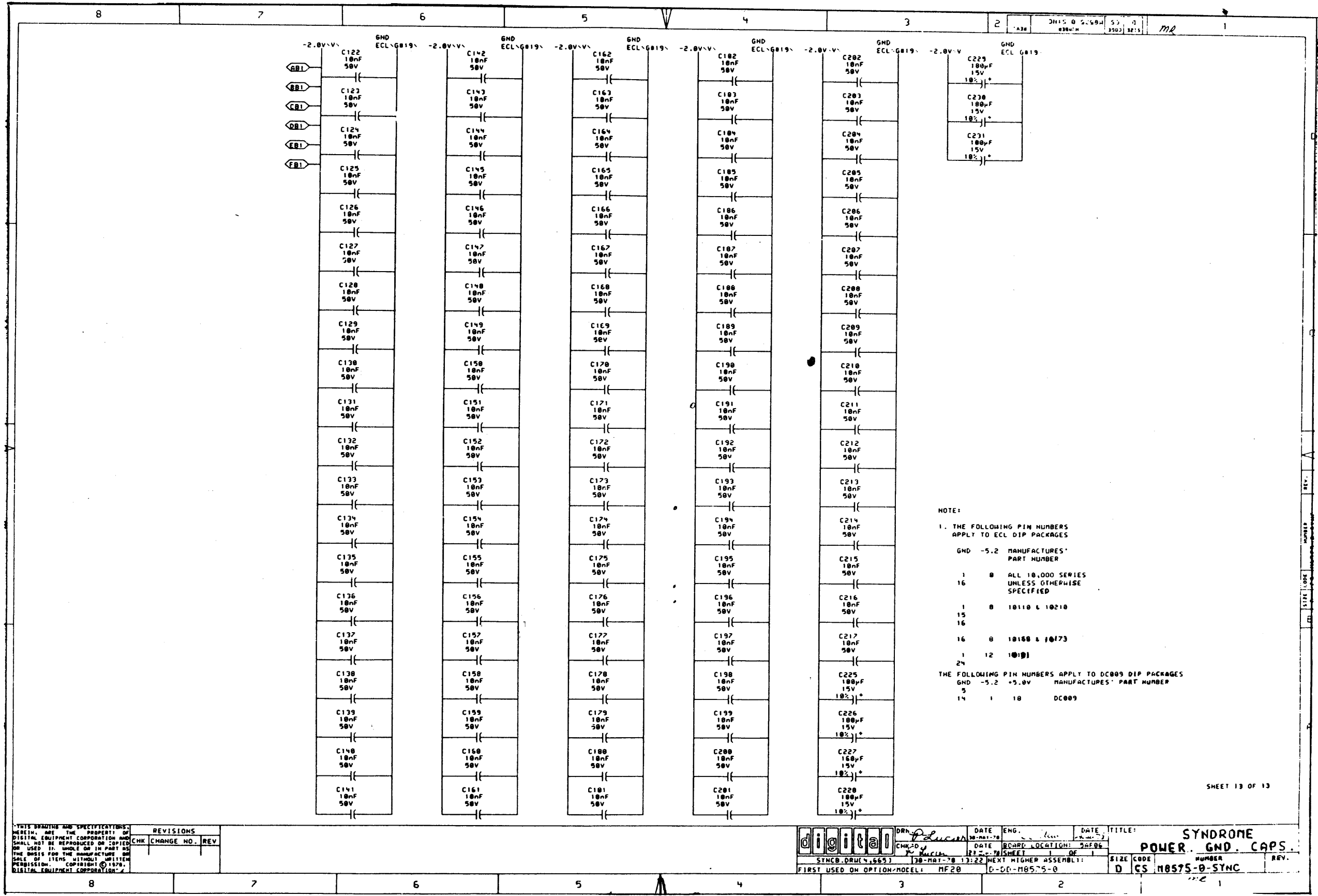

NOTE:

- THE FOLLOWING PIN NUMBERS APPLY TO ECL DIP PACKAGES
 

GND	-5.2	MANUFACTURER'S PART NUMBER
1	0	ALL 10,000 SERIES UNLESS OTHERWISE SPECIFIED
16	0	10110 & 10210
15	0	10160 & 10170
16	0	10160 & 10170
1	12	1010
24		
- THE FOLLOWING PIN NUMBERS APPLY TO DC009 DIP PACKAGES
 

GND	-5.2	+5.0V	MANUFACTURER'S PART NUMBER
5			DC009
14	1	10	DC009

THIS DRAWING AND SPECIFICATIONS HEREIN ARE THE PROPERTY OF DIGITAL EQUIPMENT CORPORATION AND SHALL NOT BE REPRODUCED OR COPIED OR USED IN WHOLE OR IN PART AS THE BASIS FOR THE MANUFACTURE OR SALE OF ITEMS WITHOUT WRITTEN PERMISSION. COPYRIGHT © 1970, DIGITAL EQUIPMENT CORPORATION.

REVISIONS		
CHK	CHANGE NO.	REV

digital	DRN: <i>Plucan</i>	DATE: 10-MAY-70	ENG: <i>...</i>	DATE: 10-MAY-70	TITLE: SYNDROME POWER GND CAPS.
	CHK'D: <i>...</i>	DATE: 10-MAY-70	DATE: 10-MAY-70	DATE: 10-MAY-70	DATE: 10-MAY-70
SYNCD: DRW 4,665		10-MAY-70 13:22	NEXT HIGHER ASSEMBLY:	SIZE CODE: D CS	NUMBER: M8575-0-SYNC
FIRST USED ON OPTION MODEL: MF20		G-00-M8575-0		REV.:	

RESISTOR LOC(PIN)	SHOWN DRN# REF	VALUE	TERMINATES SIGNAL	RESISTOR LOC(PIN)	SHOWN DRN# REF	VALUE	TERMINATES SIGNAL	RESISTOR LOC(PIN)	SHOWN DRN# REF	VALUE	TERMINATES SIGNAL	RESISTOR LOC(PIN)	SHOWN DRN# REF	VALUE	TERMINATES SIGNAL
R266(1)	SYN7 B7	60a	%E11(9)	R244(1)	SYN5 C7	60a	%E92(4)	R356(1)	SYN1 A6	60a	NOS RD DATA D14A H	R306(1)	SYN0 B4	60a	SYN0 H TO CHK D430 H
R64(1)	SYN7 A7	60a	%E10(9)	R230(1)	SYN5 C7	60a	%E92(5)	R350(1)	SYN1 A6	60a	NOS RD DATA D15A H	R153(1)	SYN0 B4	60a	SYN0 H TO CHK D43E H
R321(1)	SYN0 B7	60a	%E24(14)	R195(1)	SYN5 C7	60a	%E92(6)	R350(1)	SYN1 D5	60a	NOS RD DATA D16A H	R270(1)	SYN0 D2	60a	SYN0 SBUS TO P ADR 14 H
R326(1)	SYN0 B7	60a	%E24(15)	R219(1)	SYN0 D5	60a	ADT6 CLK FREE 01\B20\ H	R350(1)	SYN1 D5	60a	NOS RD DATA D17A H	R269(1)	SYN0 D2	60a	SYN0 SBUS TO P ADR 15 H
R322(1)	SYN0 B7	60a	%E25(14)	R109(1)	SYN6 A7	60a	ADT7 BLANK DATA H	R203(1)	SYN1 C5	60a	NOS RD DATA D18A H	R264(1)	SYN0 D2	60a	SYN0 SBUS TO P ADR 16 H
R320(1)	SYN0 B7	60a	%E25(15)	R225(1)	SYN7 C5	60a	ADT7 ERR HOLD H	R204(1)	SYN1 C5	60a	NOS RD DATA D19A H	R267(1)	SYN0 C2	60a	SYN0 SBUS TO P ADR 17 H
R150(1)	SYN5 B5	60a	%E25(7)	R271(1)	SYN7 B4	60a	CTLI ADR HOLD H	R280(1)	SYN1 B5	60a	NOS RD DATA D20A H	R209(1)	SYN0 C2	60a	SYN0 SBUS TO P ADR 18 H
R207(1)	SYN9 C5	60a	%E30(2)	R164(1)	SYN7 C5	60a	-CTL2 P ADR HOLD IN H	R201(1)	SYN1 B5	60a	NOS RD DATA D21A H	R202(1)	SYN0 C2	60a	SYN0 SBUS TO P ADR 19 H
R6(1)	SYNA C3	60a	%E32(15)	R59(1)	SYN0 C2	60a	-CTL0 DIAB CTC H	R374(1)	SYN1 A5	60a	NOS RD DATA D22A H	R276(1)	SYN0 B2	60a	SYN0 SBUS TO P ADR 20 H
R02(1)	SYNA C5	60a	%E32(2)	R174(1)	SYN1 A7	60a	H TO CHK D07 H	R329(1)	SYN1 A5	60a	NOS RD DATA D23A H	R279(1)	SYN0 B2	60a	SYN0 SBUS TO P ADR 21 H
R10(1)	SYNA C3	60a	%E32(9)	R236(1)	SYN1 D6	60a	H TO CHK D08 H	R335(1)	SYN1 D3	60a	NOS RD DATA D24A H	R257(1)	SYN0 C6	60a	SYN0 SPARE SUB 0.1 H
R11(1)	SYNA D2	60a	%E40(2)	R176(1)	SYN1 D6	60a	H TO CHK D09 H	R332(1)	SYN1 D3	60a	NOS RD DATA D25A H	R342(1)	SYN0 C6	60a	SYN0 SPARE SUB 10.11 H
R5(1)	SYNA C2	60a	%E40(3)	R175(1)	SYN1 C6	60a	H TO CHK D10 H	R343(1)	SYN1 C3	60a	NOS RD DATA D26A H	R345(1)	SYN0 C6	60a	SYN0 SPARE SUB 12.13 H
R124(1)	SYN5 B5	60a	%E45(15)	R104(1)	SYN1 C6	60a	H TO CHK D11 H	R339(1)	SYN1 C3	60a	NOS RD DATA D27A H	R354(1)	SYN0 C6	60a	SYN0 SPARE SUB 14.15 H
R120(1)	SYN9 C6	60a	%E47(3)	R102(1)	SYN1 B6	60a	H TO CHK D12 H	R351(1)	SYN1 B3	60a	NOS RD DATA D28A H	R359(1)	SYN0 B6	60a	SYN0 SPARE SUB 16.17 H
R15(1)	SYN0 A3	60a	%E47(6)	R100(1)	SYN1 B6	60a	H TO CHK D13 H	R347(1)	SYN1 B3	60a	NOS RD DATA D29A H	R207(1)	SYN0 B6	60a	SYN0 SPARE SUB 18.19 H
R123(1)	SYN5 B4	60a	%E51(3)	R352(1)	SYN1 A6	60a	H TO CHK D14 H	R300(1)	SYN1 A3	60a	NOS RD DATA D30A H	R261(1)	SYN0 C6	60a	SYN0 SPARE SUB 2.3 H
R156(1)	SYN5 B5	60a	%E52(15)	R230(1)	SYN1 A6	60a	H TO CHK D15 H	R299(1)	SYN1 A3	60a	NOS RD DATA D31A H	R206(1)	SYN0 B6	60a	SYN0 SPARE SUB 20.21 H
R7(1)	SYNA D3	60a	%E53(15)	R103(1)	SYN1 D4	60a	H TO CHK D16 H	R307(1)	SYN1 D2	60a	NOS RD DATA D32A H	R330(1)	SYN0 B6	60a	SYN0 SPARE SUB 22.23 H
R17(1)	SYNA D3	60a	%E53(9)	R101(1)	SYN1 D4	60a	H TO CHK D17 H	R309(1)	SYN1 D2	60a	NOS RD DATA D33A H	R333(1)	SYN0 B6	60a	SYN0 SPARE SUB 24.25 H
R32(1)	SYNA B2	60a	%E54(14)	R166(1)	SYN1 C4	60a	H TO CHK D18 H	R245(1)	SYN1 C2	60a	NOS RD DATA D34A H	R340(1)	SYN0 B6	60a	SYN0 SPARE SUB 26.27 H
R30(1)	SYNA B3	60a	%E54(15)	R165(1)	SYN1 C4	60a	H TO CHK D19 H	R249(1)	SYN1 C2	60a	NOS RD DATA D35A H	R340(1)	SYN0 B6	60a	SYN0 SPARE SUB 28.29 H
R24(1)	SYNA B3	60a	%E54(9)	R213(1)	SYN1 B4	60a	H TO CHK D20 H	R195(1)	SYN2 D7	60a	NOS RD DATA D36A H	R305(1)	SYN0 B6	60a	SYN0 SPARE SUB 30.31 H
R126(1)	SYN5 C5	60a	%E57(15)	R193(1)	SYN1 B4	60a	H TO CHK D21 H	R250(1)	SYN2 C7	60a	NOS RD DATA D37A H	R310(1)	SYN0 B6	60a	SYN0 SPARE SUB 32.33 H
R337(1)	SYNA C6	60a	%E67(7)	R220(1)	SYN1 C3	60a	H TO CHK D25 H	R317(1)	SYN2 B7	60a	NOS RD DATA D38A H	R240(1)	SYN0 B6	60a	SYN0 SPARE SUB 34.35 H
R42(1)	SYNA A6	60a	%E73(3)	R304(1)	SYN1 C3	60a	H TO CHK D27 H	R213(1)	SYN2 D5	60a	NOS RD DATA D39A H	R190(1)	SYN0 B6	60a	SYN0 SPARE SUB 36.37 H
R152(1)	SYN9 C5	60a	%E76(2)	R254(1)	SYN1 D0	60a	NOS RD DATA D00A H	R195(1)	SYN2 C5	60a	NOS RD DATA D40A H	R314(1)	SYN0 A6	60a	SYN0 SPARE SUB 38.39 H
R129(1)	SYN9 A6	60a	%E77(14)	R295(1)	SYN1 D0	60a	NOS RD DATA D01A H	R291(1)	SYN2 B5	60a	NOS RD DATA D41A H	R263(1)	SYN0 C6	60a	SYN0 SPARE SUB 4.5 H
R35(1)	SYNA A2	60a	%E77(2)	R299(1)	SYN1 C0	60a	NOS RD DATA D02A H	R316(1)	SYN2 D3	60a	NOS RD DATA D42A H	R197(1)	SYN0 A6	60a	SYN0 SPARE SUB 40.41 H
R37(1)	SYNA B3	60a	%E78(15)	R260(1)	SYN1 C0	60a	NOS RD DATA D03A H	R100(1)	SYN0 C4	60a	NOS RD DATA D43A H	R323(1)	SYN0 A6	60a	SYN0 SPARE SUB 42 H
R172(1)	SYNA B3	60a	%E78(9)	R265(1)	SYN1 B0	60a	NOS RD DATA D04A H	R44(1)	SYN0 D4	60a	SYN0 CLK FREE A H	R272(1)	SYN0 C6	60a	SYN0 SPARE SUB 6.7 H
R133(1)	SYN5 B7	60a	%E79(14)	R250(1)	SYN1 B0	60a	NOS RD DATA D05A H	R221(1)	SYN0 D4	60a	SYN0 CLK FREE B H	R290(1)	SYN0 C6	60a	SYN0 SPARE SUB 8.9 H
R40(1)	SYNA A7	60a	%E79(6)	R273(1)	SYN1 A0	60a	NOS RD DATA D06A H	R222(1)	SYN0 D4	60a	SYN0 CLK FREE C H	R262(1)	SYN0 B4	60a	SYN0 SUB RAM 1A H
R39(1)	SYNA A5	60a	%E80(2)	R260(1)	SYN1 A0	60a	NOS RD DATA D07A H	R110(1)	SYN0 D4	60a	SYN0 CLK FREE D H	R353(1)	SYN0 A4	60a	SYN0 SUB RAM 1B H
R224(1)	SYN9 D5	60a	%E84(9)	R292(1)	SYN1 D6	60a	NOS RD DATA D08A H	R01(1)	SYN0 D4	60a	SYN0 CLK FREE E H	R315(1)	SYN0 A4	60a	SYN0 SUB RAM 1C H
R90(1)	SYN3 B2	60a	%E86(15)	R209(1)	SYN1 D6	60a	NOS RD DATA D09A H	R120(1)	SYN0 D4	60a	SYN0 CLK FREE F H	R324(1)	SYN0 A4	60a	-SYN0 SUB RAM 1C H
R167(1)	SYN7 A7	60a	%E87(15)	R346(1)	SYN1 C6	60a	NOS RD DATA D10A H	R67(1)	SYN0 C4	60a	SYN0 HI	R119(1)	SYN0 A6	60a	SYN0 TEST H
R106(1)	SYN5 C7	60a	%E92(12)	R341(1)	SYN1 C6	60a	NOS RD DATA D11A H	R256(1)	SYN0 C4	60a	SYN0 H TO CHK D430 H	R105(1)	SYN1 D7	60a	SYN1 H TO CHK D00 H
R234(1)	SYN5 C7	60a	%E92(13)	R349(1)	SYN1 B6	60a	NOS RD DATA D12A H	R206(1)	SYN0 C4	60a	SYN0 H TO CHK D430 H	R100(1)	SYN1 D7	60a	SYN1 H TO CHK D01 H
R209(1)	SYN5 C7	60a	%E92(3)	R344(1)	SYN1 B6	60a	NOS RD DATA D13A H	R331(1)	SYN0 B4	60a	SYN0 H TO CHK D430 H	R107(1)	SYN1 C7	60a	SYN1 H TO CHK D02 H

NOTE:  
 1. ALL TERMINATORS HAVE PIN TWO CONNECTED TO -2.0V AND ARE 5% 1/4WATT UNLESS OTHERWISE SPECIFIED  
 2. ENTRIES ARE SORTED BY SIGNAL NAME  
 3. % INDICATES OUTPUT OF DIP LOC AND (<) INDICATES PIN NUMBER

THIS DRAWING AND SPECIFICATIONS HEREIN ARE THE PROPERTY OF DIGITAL EQUIPMENT CORPORATION AND SHALL NOT BE REPRODUCED OR COPIED OR USED IN WHOLE OR IN PART OR THE BASIS FOR THE MANUFACTURE OR SALE OF ITEMS WITHOUT WRITTEN PERMISSION. COPYRIGHT © 1978 DIGITAL EQUIPMENT CORPORATION

REVISIONS		
CHK	CHANGE NO.	REV

	DRN. <u>G Smith</u>	DATE <u>12-31-78</u>	ENG. <u>DJ Chen</u>	DATE <u>12/31/78</u>	TITLE: <u>SYNDROME TERMINATORS</u>
	DATE <u>12-31-78</u>	BOARD LOCATION: <u>1 DE 3</u>	DATE <u>12-31-78</u>	SIZE <u>D</u>	CODE <u>CS</u>
	FIRST USED ON OPTION/MODEL: <u>NF20</u>			NEXT HIGHER ASSEMBLY: <u>D-DD-M8575-0</u>	

SIZE	CODE	NUMBER	REV.
D	CS	M8575-0-RES	

RESISTOR LOC(PIN)	SHOWN ON DRWG	ON REF	VALUE	TERMINATES SIGNAL	RESISTOR LOC(PIN)	SHOWN ON DRWG	ON REF	VALUE	TERMINATES SIGNAL	RESISTOR LOC(PIN)	SHOWN ON DRWG	ON REF	VALUE	TERMINATES SIGNAL	RESISTOR LOC(PIN)	SHOWN ON DRWG	ON REF	VALUE	TERMINATES SIGNAL
R55(1)	SYN1	C7	60a	SYN1 N TO CHK D03 H	R57(1)	SYN3	C6	60a	SYN3 PAR B11,12,14,17 H	R215(1)	SYN5	D5	60a	SYN5 DECODE 10 H	R116(1)	SYN7	D2	60a	SYN7 ERR ADR 20 H
R179(1)	SYN1	B7	60a	SYN1 N TO CHK D04 H	R181(1)	SYN3	C6	60a	SYN3 PAR B11,13,15,17 H	R270(1)	SYN5	D5	60a	SYN5 DECODE 11 H	R71(1)	SYN7	D2	60a	SYN7 ERR ADR 21 H
R177(1)	SYN1	B7	60a	SYN1 N TO CHK D05 H	R136(1)	SYN3	C6	60a	SYN3 PAR B12,13,16,17 H	R274(1)	SYN5	D5	60a	SYN5 DECODE 12 H	R69(1)	SYN7	C6	60a	SYN7 P ADR 14 H
R178(1)	SYN1	A7	60a	SYN1 N TO CHK D06 H	R54(1)	SYN3	C6	60a	SYN3 PAR B13,15,16 H	R237(1)	SYN5	D5	60a	SYN5 DECODE 13 H	R60(1)	SYN7	C6	60a	SYN7 P ADR 15 H
R160(1)	SYN1	A4	60a	SYN1 N TO CHK D22 H	R142(1)	SYN3	C6	60a	SYN3 PAR B14,15,16,17 H	R233(1)	SYN5	D5	60a	SYN5 DECODE 14 H	R66(1)	SYN7	C6	60a	SYN7 P ADR 16 H
R162(1)	SYN1	A4	60a	SYN1 N TO CHK D23 H	R52(1)	SYN3	C2	60a	SYN3 PAR B10,21,23,24 H	R296(1)	SYN5	D5	60a	SYN5 DECODE 15 H	R65(1)	SYN7	D6	60a	SYN7 P ADR 17 H
R163(1)	SYN1	D3	60a	SYN1 N TO CHK D24 H	R53(1)	SYN3	C2	60a	SYN3 PAR B19,20,22,25 H	R294(1)	SYN5	D4	60a	SYN5 DECODE 17 H	R43(1)	SYN0	C2	60a	-SYN0 CHK DIAG T0 H
R161(1)	SYN1	D3	60a	SYN1 N TO CHK D25 H	R103(1)	SYN3	C2	60a	SYN3 PAR B19,21,23,25 H	R295(1)	SYN5	D4	60a	SYN5 DECODE 18 H	R169(1)	SYN0	D2	60a	SYN0 CHK DIAG T1 H
R291(1)	SYN1	B3	60a	SYN1 N TO CHK D20 H	R138(1)	SYN3	C2	60a	SYN3 PAR B20,21,24,25 H	R290(1)	SYN5	D4	60a	SYN5 DECODE 19 H	R22(1)	SYN0	D2	60a	-SYN0 CHK DIAG T1 H
R303(1)	SYN1	B3	60a	SYN1 N TO CHK D29 H	R144(1)	SYN3	C2	60a	SYN3 PAR B22,23,24,25 H	R243(1)	SYN5	D4	60a	SYN5 DECODE 20 H	R07(1)	SYN0	A2	60a	-SYN0 DIAG NIX EN H
R229(1)	SYN1	A3	60a	SYN1 N TO CHK D30 H	R45(1)	SYN3	B7	60a	SYN3 PAR B26,27,29,32 H	R241(1)	SYN5	D4	60a	SYN5 DECODE 21 H	R75(1)	SYN0	B2	60a	SYN0 DIAG NIX SEL 1 H
R242(1)	SYN1	A3	60a	SYN1 N TO CHK D31 H	R104(1)	SYN3	B7	60a	SYN3 PAR B26,28,30,32 H	R109(1)	SYN5	D4	60a	SYN5 DECODE 22 H	R20(1)	SYN0	A2	60a	SYN0 DIAG NIX SEL 2 H
R239(1)	SYN1	D1	60a	SYN1 N TO CHK D32 H	R139(1)	SYN3	B7	60a	SYN3 PAR B27,28,31,32 H	R192(1)	SYN5	D4	60a	SYN5 DECODE 23 H	R19(1)	SYN0	B3	60a	SYN0 DIAG SIX SEL 0 H
R96(1)	SYN1	D1	60a	SYN1 N TO CHK D33 H	R46(1)	SYN3	B7	60a	SYN3 PAR B28,30,31 H	R095(1)	SYN5	D3	60a	SYN5 DECODE 24 H	R97(1)	SYN0	B3	60a	SYN0 DIAG SIX SEL 1 H
R95(1)	SYN1	C1	60a	SYN1 N TO CHK D34 H	R145(1)	SYN3	B7	60a	SYN3 PAR B29,30,31,32 H	R201(1)	SYN5	D3	60a	SYN5 DECODE 25 H	R171(1)	SYN0	B3	60a	SYN0 DIAG SIX SEL 2 H
R99(1)	SYN1	C1	60a	SYN1 N TO CHK D35 H	R49(1)	SYN3	B5	60a	SYN3 PAR B33 TO ECC 32 H	R211(1)	SYN5	D3	60a	SYN5 DECODE 26 H	R397(1)	SYN0	C2	60a	SYN0 S DIAG CTC A H
R77(1)	SYN2	B2	60a	SYN2 CHK D43 H	R105(1)	SYN3	B1	60a	SYN3 PAR B33,34,35 H	R200(1)	SYN5	D3	60a	SYN5 DECODE 27 H	R246(1)	SYN0	C2	60a	SYN0 S DIAG CTC B H
R72(1)	SYN2	B2	60a	SYN2 CHK ECC 1 H	R151(1)	SYN4	C3	60a	SYN4 43 BIT PAR OK H	R216(1)	SYN5	D3	60a	SYN5 DECODE 28 H	R23(1)	SYN0	D4	60a	-SYN0 S DIAG FCH 00 H
R03(1)	SYN2	C2	60a	SYN2 CHK ECC 16 H	R122(1)	SYN4	D6	60a	SYN4 BIT 1 H	R210(1)	SYN5	D3	60a	SYN5 DECODE 29 H	R107(1)	SYN0	C4	60a	-SYN0 S DIAG FCH 05 H
R73(1)	SYN2	B2	60a	SYN2 CHK ECC 2 H	R147(1)	SYN4	C6	60a	SYN4 BIT 16 H	R277(1)	SYN5	D3	60a	SYN5 DECODE 30 H	R26(1)	SYN0	C4	60a	-SYN0 S DIAG FCH 06 H
R08(1)	SYN2	C2	60a	SYN2 CHK ECC 32 H	R125(1)	SYN4	D5	60a	SYN4 BIT 2 H	R275(1)	SYN5	D3	60a	SYN5 DECODE 31 H	R227(1)	SYN0	C3	60a	SYN0 S DIAG FCH 10 H
R06(1)	SYN2	C2	60a	SYN2 CHK ECC 4 H	R114(1)	SYN4	C5	60a	SYN4 BIT 32 H	R235(1)	SYN5	D2	60a	SYN5 DECODE 33 H	R226(1)	SYN0	C4	60a	-SYN0 S DIAG FCH 10 H
R92(1)	SYN2	C2	60a	SYN2 CHK ECC 8 H	R214(1)	SYN4	D3	60a	SYN4 BIT 4 H	R297(1)	SYN5	D2	60a	SYN5 DECODE 34 H	R111(1)	SYN0	C3	60a	SYN0 S DIAG FCH 12 H
R70(1)	SYN2	B2	60a	SYN2 CHK ECC PAR H	R117(1)	SYN4	D2	60a	SYN4 BIT 0 H	R293(1)	SYN5	D2	60a	SYN5 DECODE 35 H	R41(1)	SYN0	C4	60a	-SYN0 S DIAG FCH 12 H
R132(1)	SYN2	B4	60a	SYN2 N TO CHK ECC 1 H	R76(1)	SYN4	B3	60a	SYN4 BUF 1 H	R302(1)	SYN5	D2	60a	SYN5 DECODE 36 H	R194(1)	SYN0	D6	60a	SYN0 HR DATA D07 H
R106(1)	SYN2	C6	60a	SYN2 N TO CHK ECC 16 H	R05(1)	SYN4	B5	60a	SYN4 BUF 16 H	R232(1)	SYN5	D2	60a	SYN5 DECODE 37 H	R252(1)	SYN0	D6	60a	SYN0 HR DATA D08 H
R134(1)	SYN2	C4	60a	SYN2 N TO CHK ECC 2 H	R74(1)	SYN4	B3	60a	SYN4 BUF 2 H	R247(1)	SYN5	D2	60a	SYN5 DECODE 38 H	R310(1)	SYN0	D6	60a	SYN0 HR DATA D09 H
R47(1)	SYN2	D6	60a	SYN2 N TO CHK ECC 32 H	R90(1)	SYN4	B5	60a	SYN4 BUF 32 H	R240(1)	SYN5	D2	60a	SYN5 DECODE 39 H	R311(1)	SYN0	C6	60a	SYN0 HR DATA D10 H
R140(1)	SYN2	D4	60a	SYN2 N TO CHK ECC 4 H	R91(1)	SYN4	A5	60a	SYN4 BUF 4 H	R190(1)	SYN5	D1	60a	SYN5 DECODE 40 H	R293(1)	SYN0	C6	60a	SYN0 HR DATA D11 H
R48(1)	SYN2	B6	60a	SYN2 N TO CHK ECC 0 H	R93(1)	SYN4	B5	60a	SYN4 BUF 0 H	R193(1)	SYN5	D1	60a	SYN5 DECODE 41 H	R196(1)	SYN0	C6	60a	SYN0 HR DATA D12 H
R131(1)	SYN2	D2	60a	SYN2 N TO CHK ECC PAR H	R79(1)	SYN4	B3	60a	SYN4 BUF CORR ERR H	R146(1)	SYN5	D1	60a	SYN5 DECODE 42 H	R319(1)	SYN0	C6	60a	SYN0 HR DATA D13 H
R56(1)	SYN3	C7	60a	SYN3 PAR B00,01,02 H	R00(1)	SYN4	A3	60a	SYN4 BUF DOUBLE H	R191(1)	SYN5	A4	60a	SYN5 DOUBLE ERROR H	R149(1)	SYN0	C6	60a	SYN0 HR DATA D14 H
R100(1)	SYN3	C7	60a	SYN3 PAR B00,01,03 H	R301(1)	SYN4	B6	60a	-SYN4 TO CORR PAR H	R04(1)	SYN7	B2	60a	SYN7 BLK ADR PAR H	R170(1)	SYN0	B6	60a	SYN0 HR DATA D15 H
R135(1)	SYN3	C7	60a	SYN3 PAR B00,02,03 H	R300(1)	SYN5	B3	60a	-SYN5 COMP CORR TO P PAR H	R113(1)	SYN7	A7	60a	SYN7 DIAG LOAD TIME H	R168(1)	SYN0	B6	60a	-SYN0 HR DATA D15 H
R141(1)	SYN3	C7	60a	SYN3 PAR B01,02,03 H	R157(1)	SYN5	A5	60a	SYN5 CORR ERROR H	R20(1)	SYN7	D4	60a	SYN7 ERR ADR 14 H	R204(1)	SYN0	C6	60a	SYN0 HR DATA D24 H
R50(1)	SYN3	C4	60a	SYN3 PAR B04,05,07,10 H	R202(1)	SYN5	D7	60a	SYN5 DECODE 03 H	R27(1)	SYN7	D4	60a	SYN7 ERR ADR 15 H	R203(1)	SYN0	C6	60a	SYN0 HR DATA D25 H
R102(1)	SYN3	C4	60a	SYN3 PAR B04,06,00,10 H	R200(1)	SYN5	D7	60a	SYN5 DECODE 05 H	R14(1)	SYN7	D4	60a	SYN7 ERR ADR 16 H	R29(1)	SYN0	B6	60a	SYN0 HR DATA D26 H
R137(1)	SYN3	C4	60a	SYN3 PAR B05,06,09,10 H	R212(1)	SYN5	D7	60a	SYN5 DECODE 06 H	R130(1)	SYN7	D4	60a	SYN7 ERR ADR 17 H	R231(1)	SYN0	B6	60a	-SYN0 HR DATA D26 H
R51(1)	SYN3	C4	60a	SYN3 PAR B06,00,09 H	R210(1)	SYN5	D7	60a	SYN5 DECODE 07 H	R110(1)	SYN7	D2	60a	SYN7 ERR ADR 18 H	R200(1)	SYN0	B6	60a	SYN0 HR DATA D27 H
R143(1)	SYN3	C4	60a	SYN3 PAR B07,00,09,10 H	R217(1)	SYN5	D5	60a	SYN5 DECODE 09 H	R112(1)	SYN7	D2	60a	SYN7 ERR ADR 19 H	R94(1)	SYN0	B6	60a	-SYN0 HR DATA D27 H

NOTE:  
1. ALL TERMINATORS HAVE PIN TWO CONNECTED TO -2.0V AND ARE 1/4WATT UNLESS OTHERWISE SPECIFIED  
2. ENTRIES ARE SORTED BY SIGNAL NAME  
3. % INDICATES OUTPUT OF DIP LOC AND (<) INDICATES PIN NUMBER

THIS DRAWING AND SPECIFICATIONS HEREIN ARE THE PROPERTY OF DIGITAL EQUIPMENT CORPORATION AND SHALL NOT BE REPRODUCED OR COPIED OR USED IN WHOLE OR IN PART AS THE BASIS FOR THE MANUFACTURE OR SALE OF ITEMS WITHOUT WRITTEN PERMISSION. COPYRIGHT © 1974.

REVISIONS		
CHK	CHANGE NO.	REV

**digital** ORN: G Smith DATE: 10-28-70 ENG: D. J. Chin DATE: 10/28/70  
7000  
72-50-78 SHEET 2 OF 3  
D05752.DRW 4.663 107-JUN-70 15130 NEXT HIGHER ASSEMBLY: D-DD-10575-0  
FIRST USED ON OPTION MODEL: MF20  
TITLE: SYNDROME TERMINATORS  
SIZE CODE: D CS NUMBER: M8575-0-RES REV: ME

RESISTOR LOC(PIN)	SHOWN ON DRWG	ON REF	VALUE	TERMINATES SIGNAL
R61(1)	SYND	B6	60Ω	SYND MR DATA D32 H
R60(1)	SYND	B6	60Ω	-SYND MR DATA D32 H
R53(1)	SYND	B6	60Ω	SYND MR DATA D33 H
R50(1)	SYND	A6	60Ω	SYND MR DATA D34 H
R62(1)	SYND	A6	60Ω	SYND MR DATA D35 H
R154(1)	SYND	D5	60Ω	SYND CHK HOLD ECC,SYND H
R150(1)	SYND	C4	60Ω	SYND CORR DISABLE H
R312(1)	SYND	D5	60Ω	SYND S DIAG FORCE 0'S H
R89(1)	SYND	D4	60Ω	SYND +12 HARB H
R16(1)	SYND	C4	60Ω	SYND +12 HARB EN H
R70(1)	SYND	D4	60Ω	SYND +5 HARB H
R12(1)	SYND	C4	60Ω	SYND +5 HARB EN H
R21(1)	SYND	D4	60Ω	SYND -2 HARB H
R25(1)	SYND	C4	60Ω	SYND -2 HARB EN H
R127(1)	SYND	D4	60Ω	SYND -5.2 HARB H
R173(1)	SYND	C4	60Ω	SYND -5.2 HARB EN H
R330(1)	SYND	A5	60Ω	SYND CHK PWR BAD H
R30(1)	SYND	B6	60Ω	SYND CHK PWR OK H
R220(1)	SYND	B6	60Ω	-SYND CHK PWR OK H
R121(1)	SYND	B5	60Ω	-SYND LOAD MARGIN H
R223(1)	SYND	B4	60Ω	MRPS SUB RAN 1 H
R140(1)	SYND	B7	60Ω	MRPS SUB RAN 16 H
R320(1)	SYND	C6	60Ω	MRPS SUB RAN 2 H
R115(1)	SYND	B7	60Ω	MRPS SUB RAN 32 H
R325(1)	SYND	C6	60Ω	MRPS SUB RAN 4 H
R327(1)	SYND	C6	60Ω	MRPS SUB RAN 8 H

NOTE:  
 1. ALL TERMINATORS HAVE PIN TWO CONNECTED TO -2.0V AND ARE 5% 1/4WATT UNLESS OTHERWISE SPECIFIED  
 2. ENTRIES ARE SORTED BY SIGNAL NAME  
 3. X INDICATES OUTPUT OF DIP LOC AND ( ) INDICATES PIN NUMBER

THIS DRAWING AND SPECIFICATIONS HEREIN ARE THE PROPERTY OF DIGITAL EQUIPMENT CORPORATION AND SHALL NOT BE REPRODUCED OR COPIED OR USED IN WHOLE OR IN PART AS THE BASIS FOR THE MANUFACTURE OR SALE OF ITEMS WITHOUT WRITTEN PERMISSION. COPYRIGHT © 1979. DIGITAL EQUIPMENT CORPORATION.

REVISIONS	
CHK	CHANGE NO. REV

	DRW. <i>Smith</i> DATE <i>10-2-78</i>	ENG. <i>J. Allen</i> DATE <i>10-2-78</i>	TITLE: SYNDROME TERMINATORS
	DATE BOARD LOCATION: <i>107-401-28 1918</i>	DATE: <i>10-2-78</i> SHEET <i>3</i> OF <i>3</i>	SIZE CODE NUMBER REV.
FIRST USED ON OPTION/MODEL: <i>MF20</i>		D-DD-M8575-0	D CS M8575-0-RES

DRAWING NUMBER	PAGE	PART NO.	DESCRIPTION	REVISIONS
FILE: ORIGINAL LAYOUT				
ECO NUMBER				1
MODULE REVISION				A B
E-UA-M8576-0-0	4		MOS CONTROL	A B
D-UA-M8576-0-0	1		MOS CONTROL	A B
K-PL-M8576-0-DBP	2		PARTS LIST	A B
D-CS-M8576-0-CTL0	1		SBUS DRVR & RCVR	- -
D-CS-M8576-0-CTL1	1		START LOGIC	- A
D-CS-M8576-0-CTL2	1		CYCLE CONTROL	- A
D-CS-M8576-0-CTL3	1		WRITE DATA MOVER	- A
D-CS-M8576-0-CTL4	1		ERR REG & ACKN	- A
D-CS-M8576-0-CTL5	1		READ DATA MIXER	- -
D-CS-M8576-0-CTL6	1		DATA VALID	- -
D-CS-M8576-0-CTL7	1		DIAGNOSTIC MOVER	- -
D-CS-M8576-0-CTL8	1		DIAGNOSTIC CNTRL	- A
D-CS-M8576-0-CTL9	1		SM PROM CONTROL	- -
D-CS-M8576-0-CTLA	1		RAS & SEL DRVR	- -
D-CS-M8576-0-CTLB	1		POWER. GND. CAPS.	- -
D-CS-M8576-0-CTLC	1		POWER. GND. CAPS.	- -
D-CS-M8576-0-RES	2		TERMINATORS	- A
E-MD-5012900-0-0	6		DRILL & ETCH DRAWING	A A
		5012900	ETCH CIRCUIT BOARD	D D
K-PC-M8576-0-DBC	-		P.C. DESIGN DATA BASE	A A
P00-M8576-00	-		PROCESS SHEET (REF ONLY)	- -
NOTES:				

THIS DRAWING AND SPECIFICATIONS  
HEREIN ARE THE PROPERTY OF  
DIGITAL EQUIPMENT CORPORATION AND  
SHALL NOT BE REPRODUCED OR COPIED  
OR USED IN WHOLE OR IN PART AS  
THE BASIS FOR THE MANUFACTURE OR  
SALE OF ITEMS WITHOUT WRITTEN  
PERMISSION. COPYRIGHT © 1978,  
DIGITAL EQUIPMENT CORPORATION.

REVISIONS	CHG	CHANGE NO.	REV
		M8576-MR001	A
			B
			C
			D
			E
			F
			G
			H
			I
			J
			K
			L
			M
			N
			O
			P
			Q
			R
			S
			T
			U
			V
			W
			X
			Y
			Z

DATE: 20-01-78	ENG: [Signature]	DATE: 13-02-77	TITLE: MOS CONTROL
DATE: 11-06-77	BOARD LOCATION: 9AEM3	SHEET: 1	OF: 1
SIZE: D	CODE: DD	NUMBER: M8576-0	REV.: A
FIRST USED ON OPTION/MODEL: MF20	NONE		

REV. A  
 NUMBER M8576-0  
 DDD  
 B  
 A



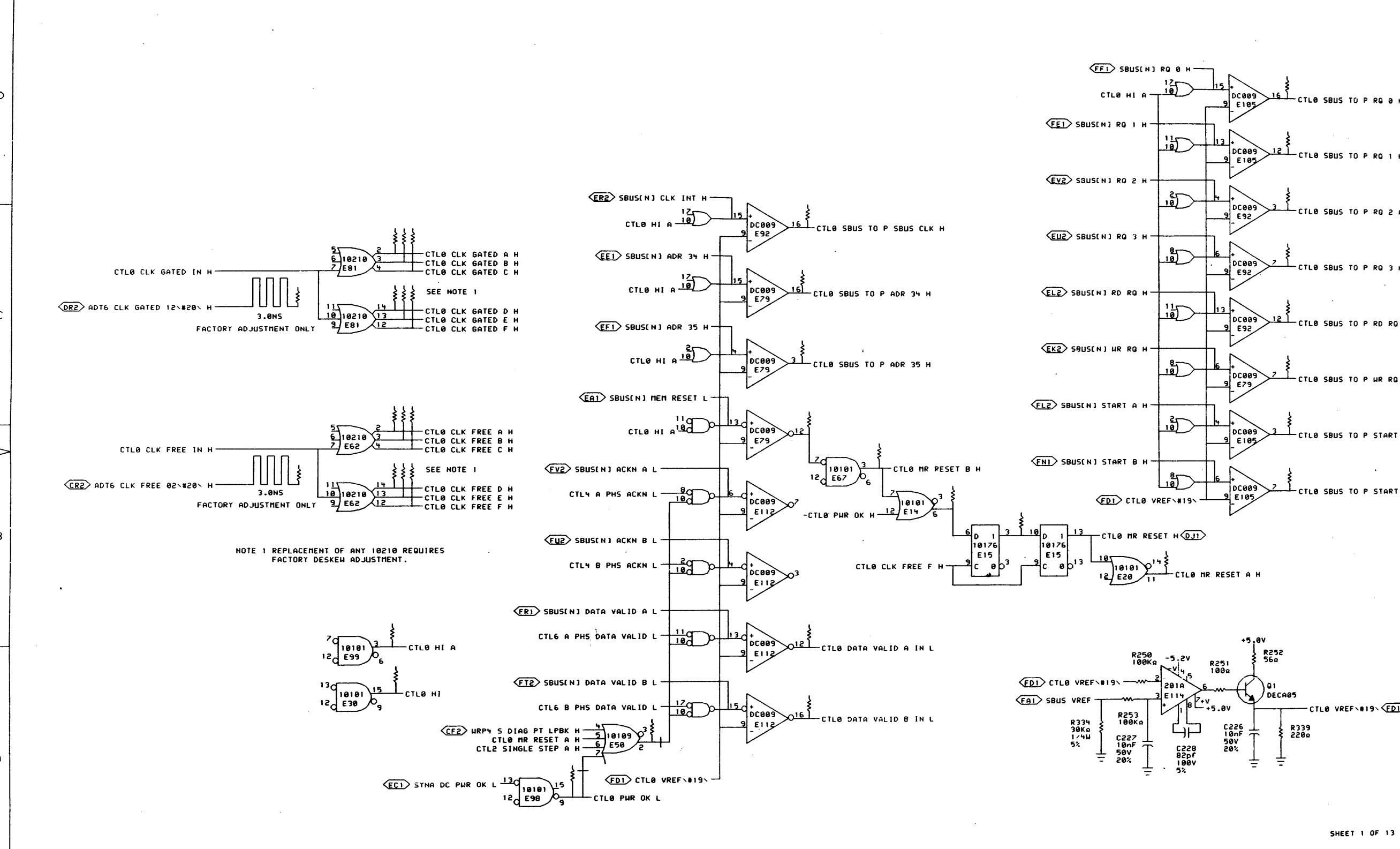

REV. NUMBER  
D CS M8576-0-CTL0  
SIZE CODE  
D CS  
B  
A

SHEET 1 OF 13

THIS DRAWING AND SPECIFICATIONS, HEREIN, ARE THE PROPERTY OF DIGITAL EQUIPMENT CORPORATION AND SHALL NOT BE REPRODUCED OR COPIED OR USED IN WHOLE OR IN PART AS THE BASIS FOR THE MANUFACTURE OR SALE OF ITEMS, WITHOUT WRITTEN PERMISSION. COPYRIGHT © 1978, DIGITAL EQUIPMENT CORPORATION.

REVISIONS	
CHK	CHANGE NO. REV

digital	DRN <i>P. Lucian</i>	DATE ENG. 18-JUL-78	DATE	TITLE: MOS CONTROL SBUS DRVR & RCVR
	CHK <i>P. Lucian</i>	DATE BOARD LOCATION: 5AF85	DATE	NUMBER
PLB: M8576-MOS>CTL0B.DRW 18-JUL-78 11:44		NEXT HIGHER ASSEMBLY:	SIZE CODE	REV.
FIRST USED ON OPTION/MODEL: MF20		D-DD-M8576-0	D CS	M8576-0-CTL0

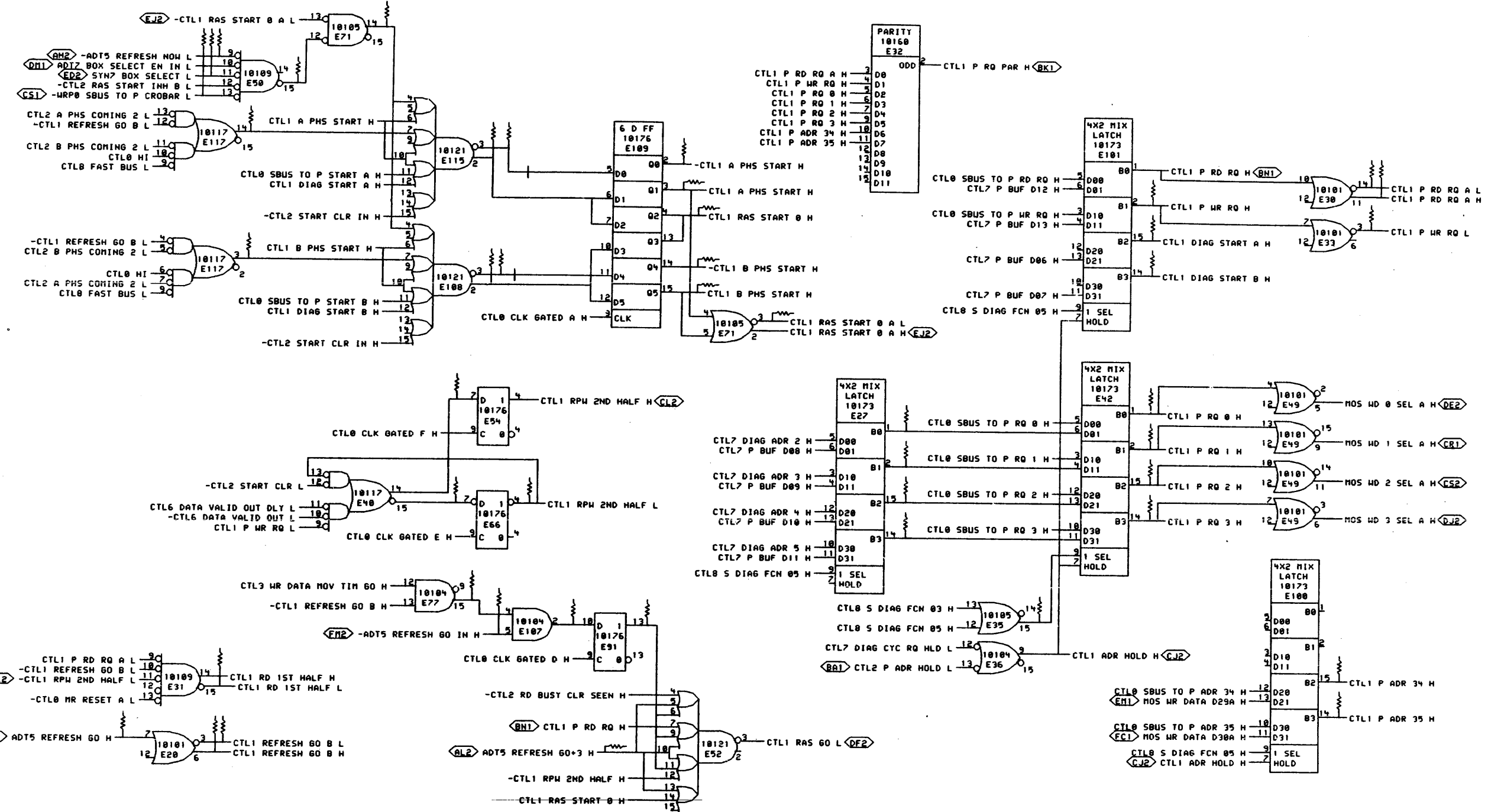

REVISIONS
CHK CHANGE NO. REV
DATE
BY
DESCRIPTION

digital	DRN <i>P. Lucas</i>	DATE 20-OCT-78	ENG <i>Smith</i>	DATE 11/16/79	TITLE: MOS CONTROL START LOGIC
	CHK'D <i>Ch. M. M...</i>	DATE 11/16/79	BOARD LOCATION: 5A805	SHEET 1 OF 1	SIZE CODE D CS
PUB: M8576-MOS>CTL1B.DRW106-OCT-78 09:52			NEXT HIGHER ASSEMBLY:	NUMBER M8576-0-CTL1	REV. A
FIRST USED ON OPTION/MODEL: MF20			D-DD-M8576-0	MR	

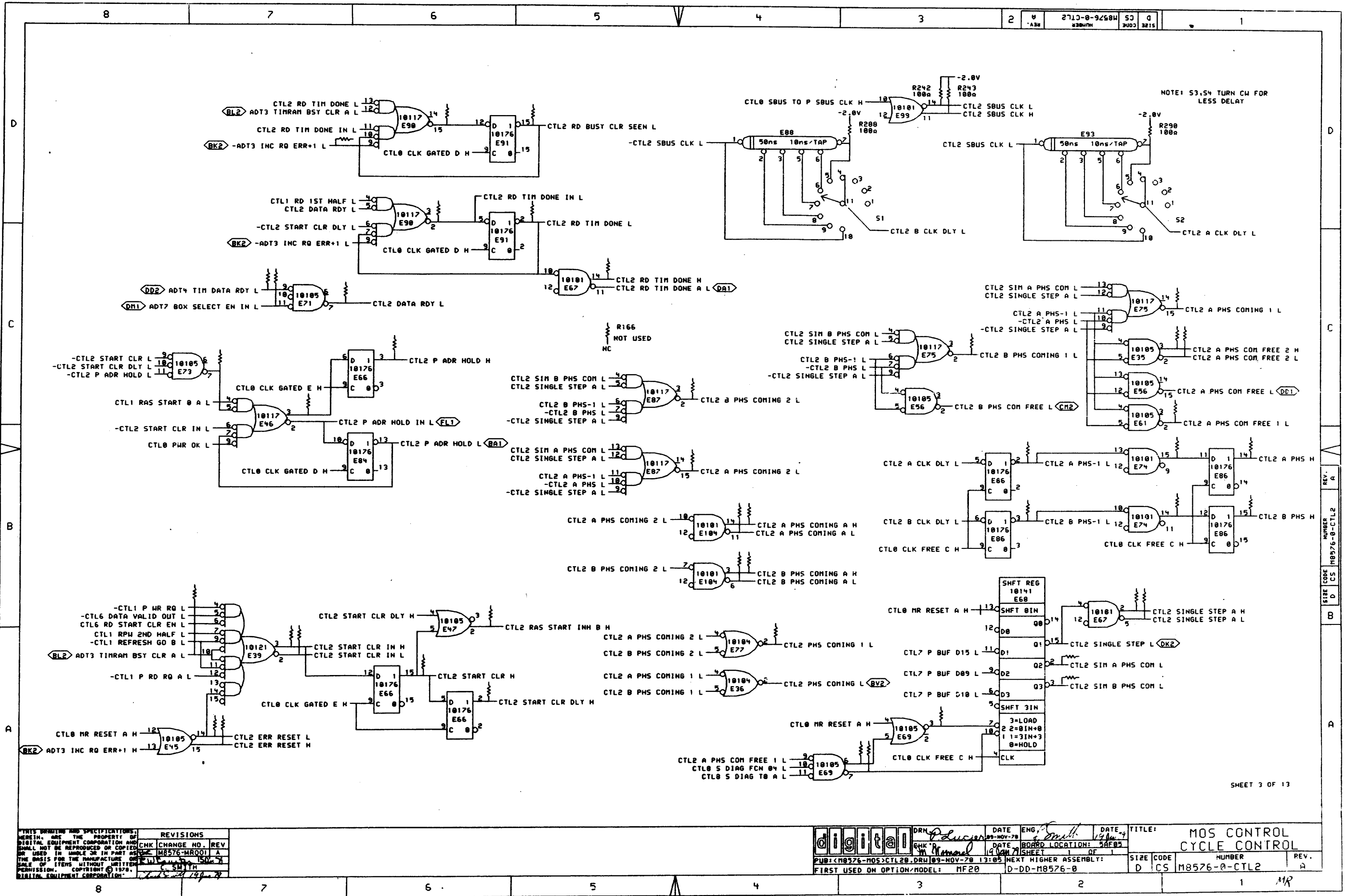

NOTE: 53.54 TURN CW FOR LESS DELAY

REV. A  
 NUMBER 10141  
 SIZE CODE CS  
 MODEL M8576-0-CTL2

SHEET 3 OF 13

THIS DRAWING AND SPECIFICATIONS HEREIN ARE THE PROPERTY OF DIGITAL EQUIPMENT CORPORATION AND SHALL NOT BE REPRODUCED OR COPIED OR USED IN WHOLE OR IN PART AS THE BASIS FOR THE MANUFACTURE OR SALE OF ITEMS WITHOUT WRITTEN PERMISSION. COPYRIGHT © 1978. DIGITAL EQUIPMENT CORPORATION.

REV.	CHG. NO.	DESCRIPTION
1	1	INITIAL DESIGN
2	1	REVISION

DATE	ENG.	DATE	REV.
09-NOV-78	Smith	12/1/78	1
19-NOV-78	Smith	12/1/78	2

DATE: 19-NOV-78  
 ENG: Smith  
 DATE: 12/1/78  
 REV: 2

TITLE: MOS CONTROL CYCLE CONTROL

BOARD LOCATION: 5AF85

SHEET 1 OF 1

SIZE CODE: D CS

MODEL: M8576-0-CTL2

REV. A

REV.	NUMBER	MODEL
A	10141	M8576-0-CTL2

REV. A  
 NUMBER 10141  
 MODEL M8576-0-CTL2

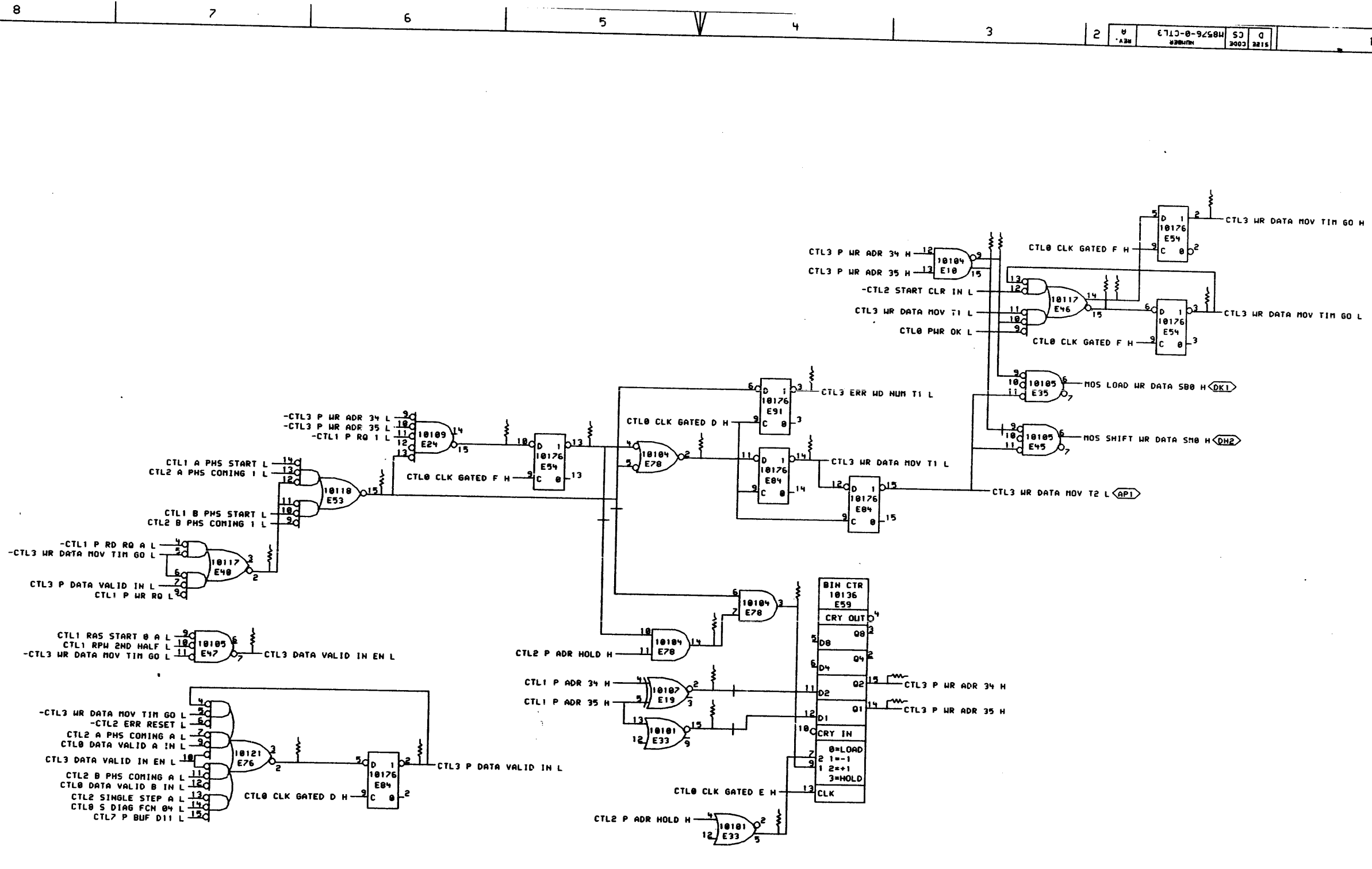

SHEET 4 OF 13

THIS DRAWING AND SPECIFICATIONS ARE THE PROPERTY OF DIGITAL EQUIPMENT CORPORATION AND SHALL NOT BE REPRODUCED OR COPIED OR USED IN WHOLE OR IN PART AS BASIS FOR THE MANUFACTURE OR SALE OF ITEMS WITHOUT WRITTEN PERMISSION. COPYRIGHT © 1979 DIGITAL EQUIPMENT CORPORATION.

REVISIONS	CHK	CHANGE NO.	REV.

DRN	DATE	ENG	DATE	TITLE:
<i>P. Lucier</i>	28-OCT-78	<i>C. Smith</i>	12-2-77	MOS CONTROL
CHK'D	DATE	BOARD LOCATION:	DATE	WRITE DATA MOVER
<i>M. M...</i>	11-29-78	5A8A5	11-29-78	
PUB: M8576-MOS>CTL3B.DRW	22-SEP-78	14184	1	1
FIRST USED ON OPTION/MODEL:	MF20	D-DD-M8576-0		

SIZE	CODE	NUMBER	REV.
D	CS	M8576-0-CTL3	A

REV. A  
 M8576-0-CTL3

MR

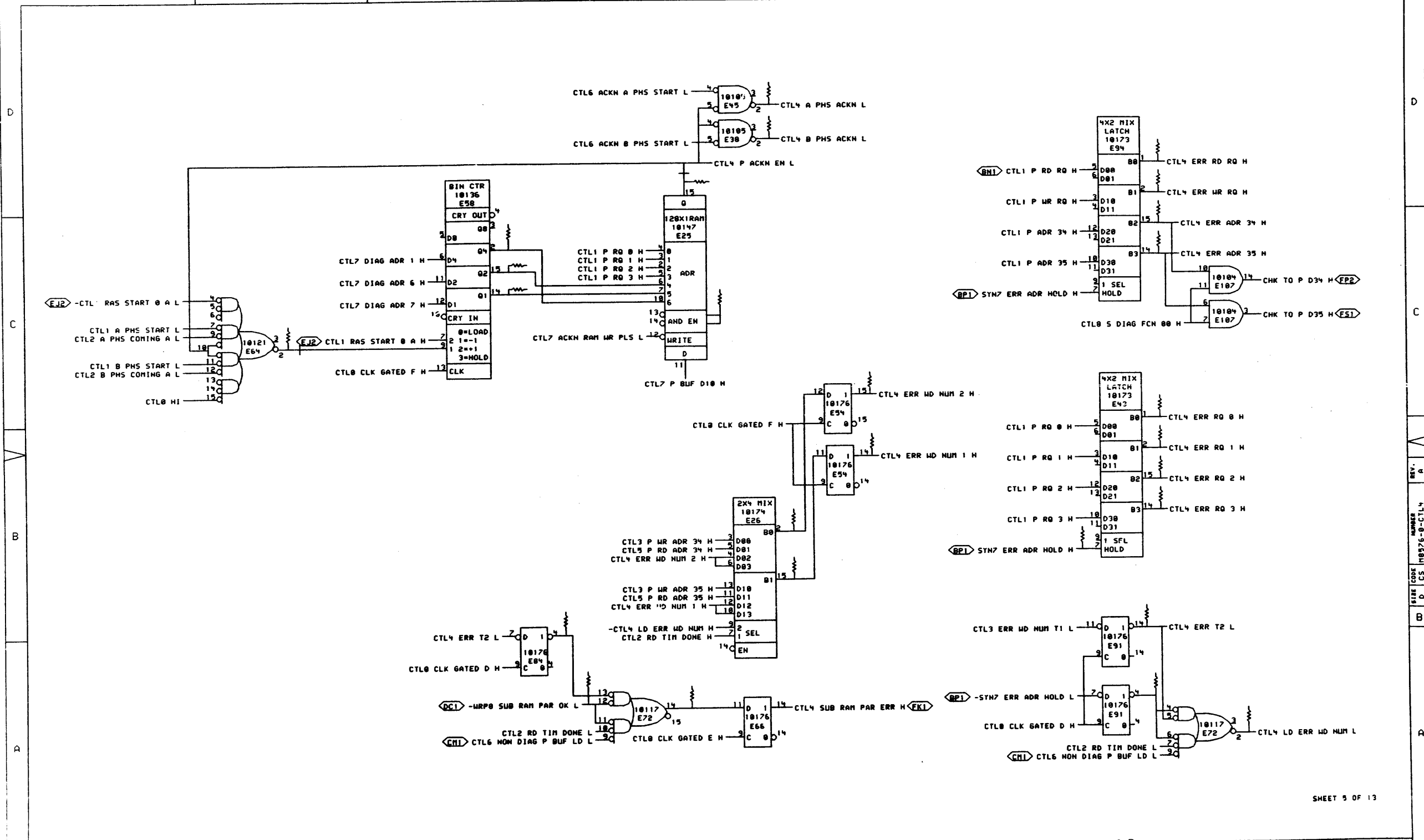

SHEET 5 OF 13

THIS DRAWING AND SPECIFICATIONS ARE THE PROPERTY OF DIGITAL EQUIPMENT CORPORATION AND SHALL NOT BE REPRODUCED OR COPIED OR USED IN WHOLE OR IN PART AS THE BASIS FOR THE MANUFACTURE OF ANY ITEM WITHOUT WRITTEN PERMISSION. COPYRIGHT © 1978.

REV.	CHG.	NO.	REV.
1	1	1	A
2	1	1	A

DATE	DESIGNER	DATE	CHK'D	DATE	DRN	DATE	ENG	DATE	TITLE
10/29/78	W. M. M...	10/29/78	W. M. M...	10/29/78	W. M. M...	10/29/78	W. M. M...	10/29/78	MOS CONTROL ERR REG & ACKN

SIZE	CODE	NUMBER	REV.
D	CS	M8576-0-CTL4	A

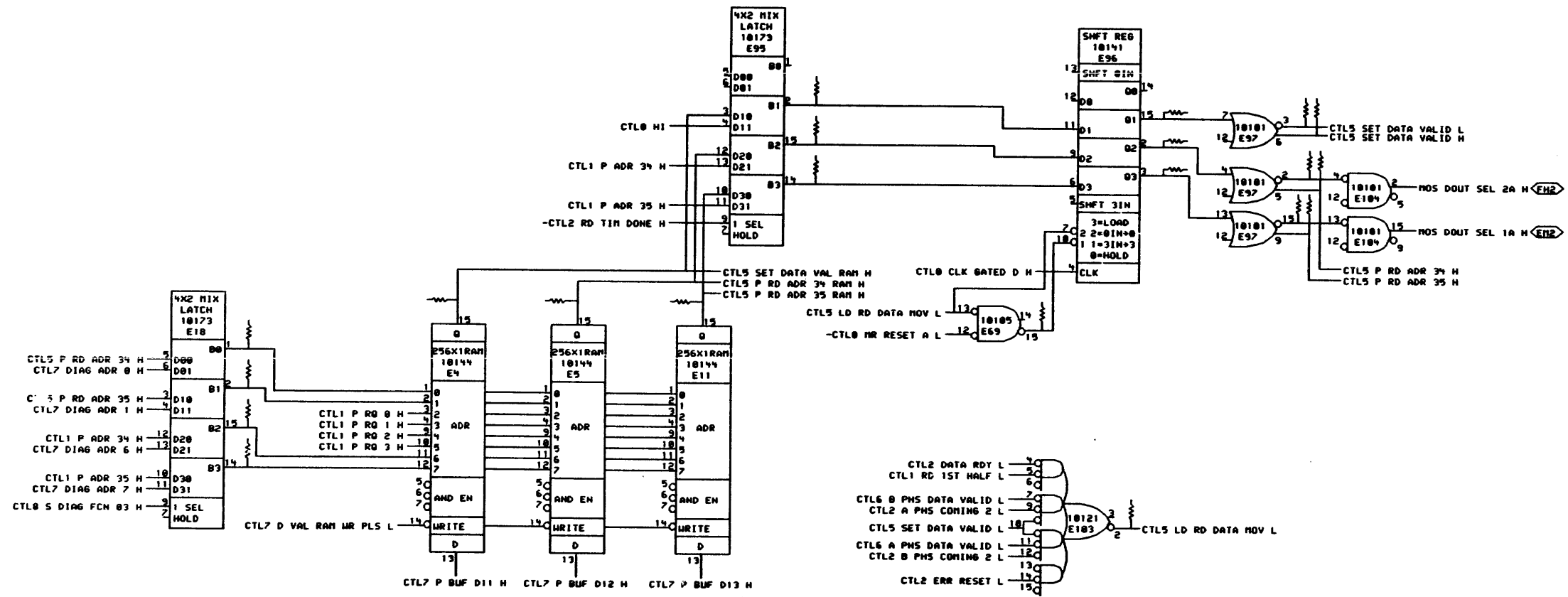

THIS DRAWING AND SPECIFICATIONS, HEREIN, ARE THE PROPERTY OF DIGITAL EQUIPMENT CORPORATION AND SHALL NOT BE REPRODUCED OR COPIED OR USED IN WHOLE OR IN PART AS THE BASIS FOR THE MANUFACTURE OR SALE OF ITEMS WITHOUT WRITTEN PERMISSION.  
 COPYRIGHT © 1979, DIGITAL EQUIPMENT CORPORATION

REVISIONS		
CHK	CHANGE NO.	REV

	DRN <i>Lucien</i>	DATE 27-MAR-78	ENG. <i>J. Chen</i>	DATE 27-MAR-78	TITLE: MOS CONTROL READ DATA MOVER
	CHK <i>Lucien</i>	DATE 01-MAY-78	BOARD LOCATION: 3AF85	SHEET 1 OF 1	SIZE CODE NUMBER
CTL5B.DRW 4,666 FIRST USED ON OPTION/MODEL: MF20		01-MAY-78 18:10	NEXT HIGHER ASSEMBLY: D-DD-M8576-0	SIZE CODE NUMBER	REV.

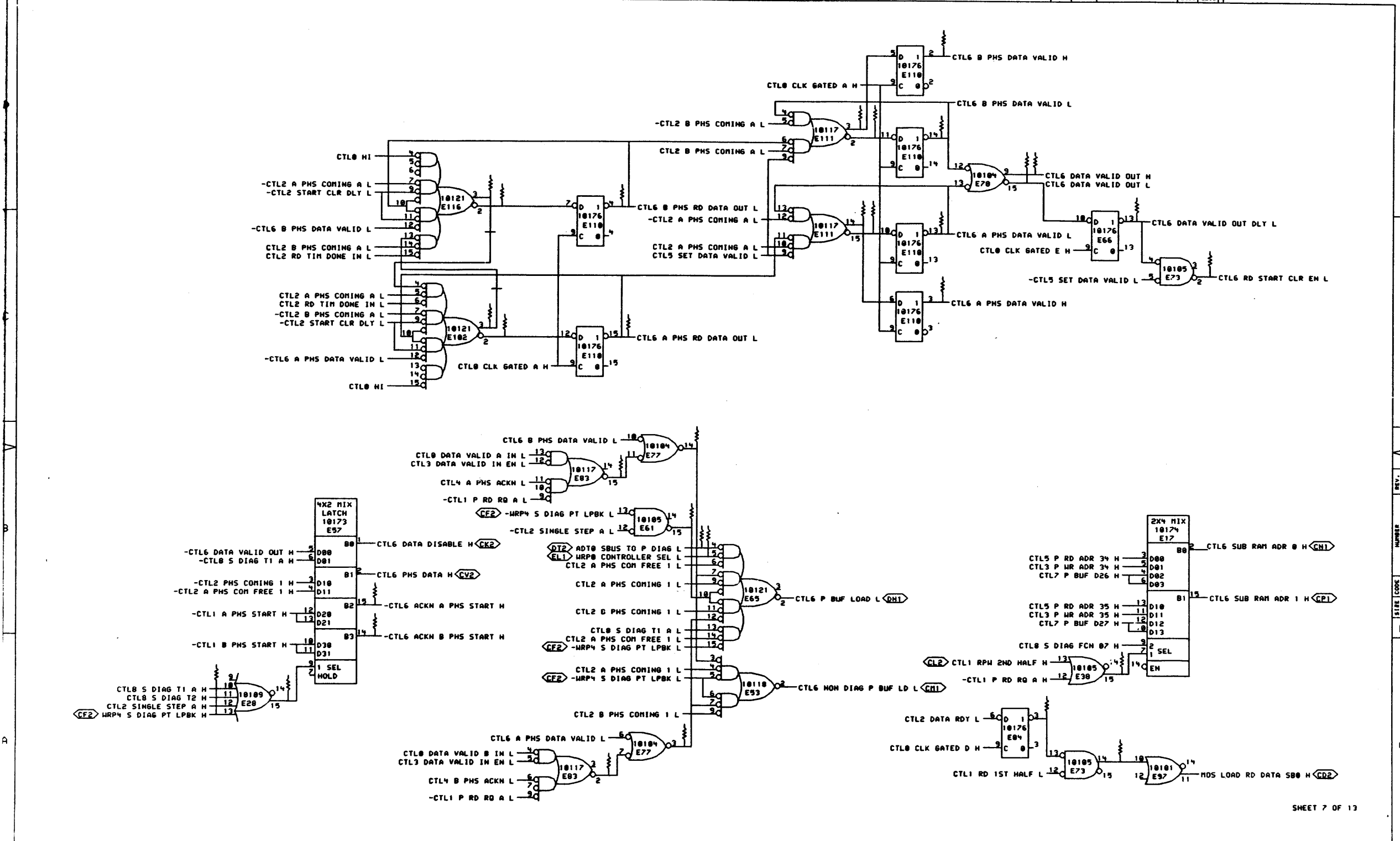

THIS DRAWING AND SPECIFICATIONS, HEREIN, ARE THE PROPERTY OF DIGITAL EQUIPMENT CORPORATION AND SHALL NOT BE REPRODUCED OR COPIED OR USED IN WHOLE OR IN PART AS THE BASIS FOR THE MANUFACTURE OR SALE OF ITEMS WITHOUT WRITTEN PERMISSION.  
 COPYRIGHT © 1978, DIGITAL EQUIPMENT CORPORATION

REVISIONS		
CHK	CHANGE NO.	REV.

	DRN: <i>Plumier</i>	DATE: <i>11-10-78</i>	ENG: <i>D.J. Chen</i>	DATE: <i>11-10-78</i>	TITLE: MOS CONTROL DATA VALID
	CHK: <i>Plumier</i>	DATE: <i>11-10-78</i>	BOARD LOCATION: <i>5A05</i>	SHEET: <i>1</i>	OF: <i>1</i>
CTL6B.DRW 4,666	01-MAY-78 10:12	NEXT HIGHER ASSEMBLY:		SIZE CODE: <i>me</i>	NUMBER: D CS M8576-0-CTL6
FIRST USED ON OPTION/MODEL: MF20	D-DD-M8576-0			REV.:	

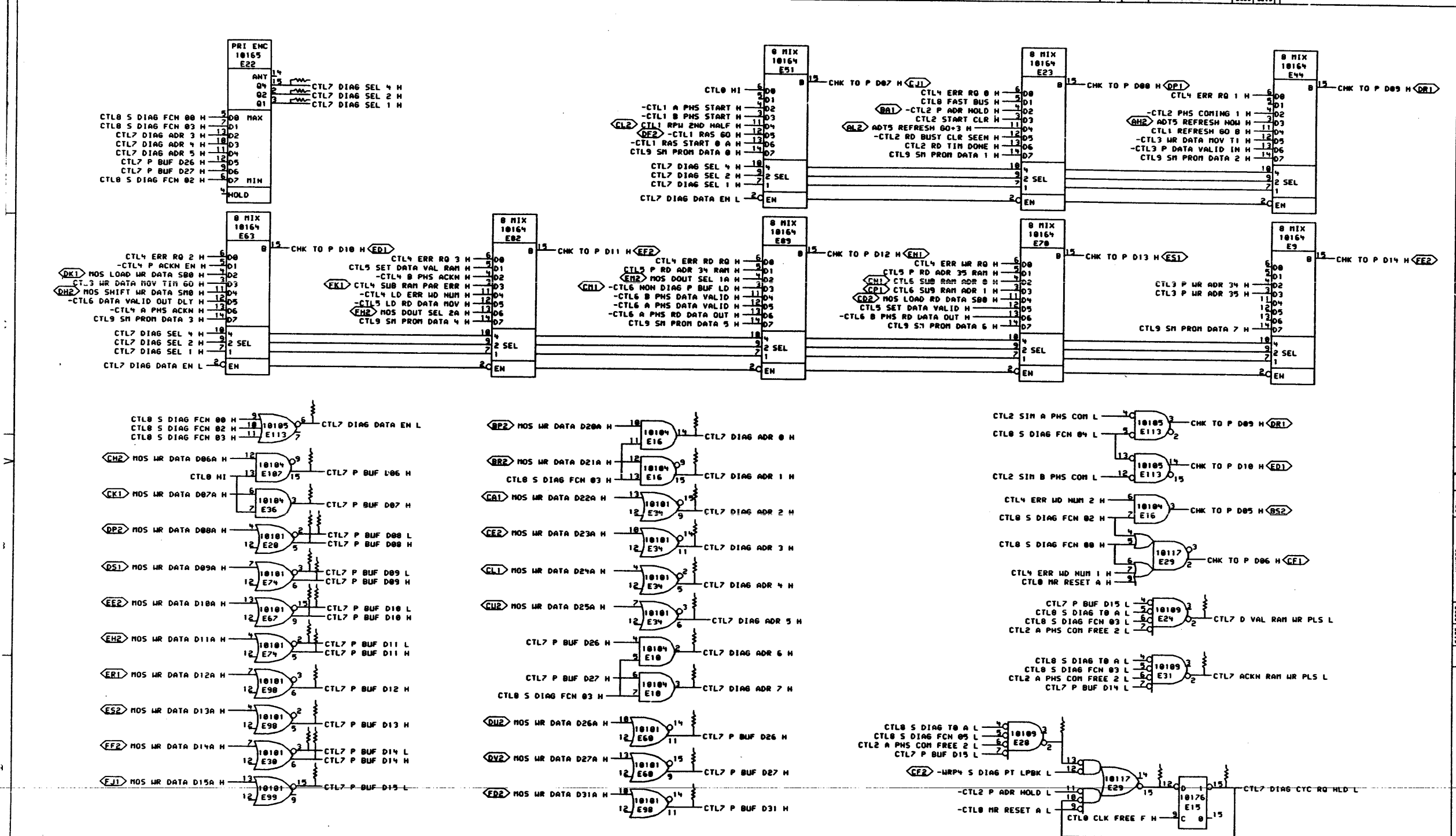

THIS DRAWING AND SPECIFICATIONS HEREIN ARE THE PROPERTY OF DIGITAL EQUIPMENT CORPORATION AND SHALL NOT BE REPRODUCED OR COPIED OR USED IN WHOLE OR IN PART AS THE BASIS FOR THE MANUFACTURE OR SALE OF ITEMS WITHOUT WRITTEN PERMISSION. COPYRIGHT © 1978, DIGITAL EQUIPMENT CORPORATION.

REVISIONS	CHK	CHANGE NO.	REV

<b>digital</b>	DRN: <i>Lucia</i>	DATE: 11-MAY-78	ENG: <i>DJ Clun</i>	DATE: <i>11-MAY-78</i>	TITLE: MOS CONTROL DIAGNOSTIC MIXER
CTL7B, DRUEN, 6663	CHK: <i>DJ Clun</i>	DATE: 19-MAY-78 14:42	BOARD LOCATION: 3AF05	SHEET: 1 OF 1	SIZE CODE: D CS
FIRST USED ON OPTION/MODEL: MF20		NEXT HIGHER ASSEMBLY: D-DD-M8576-0			NUMBER: M8576-0-CTL7

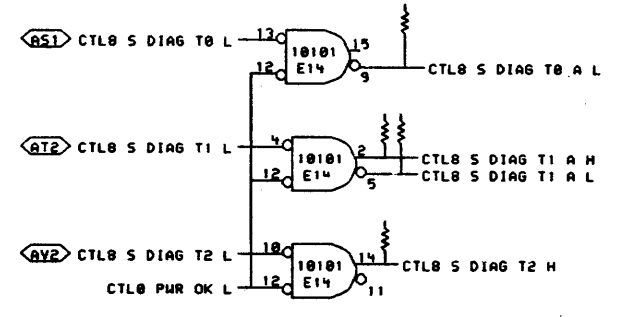
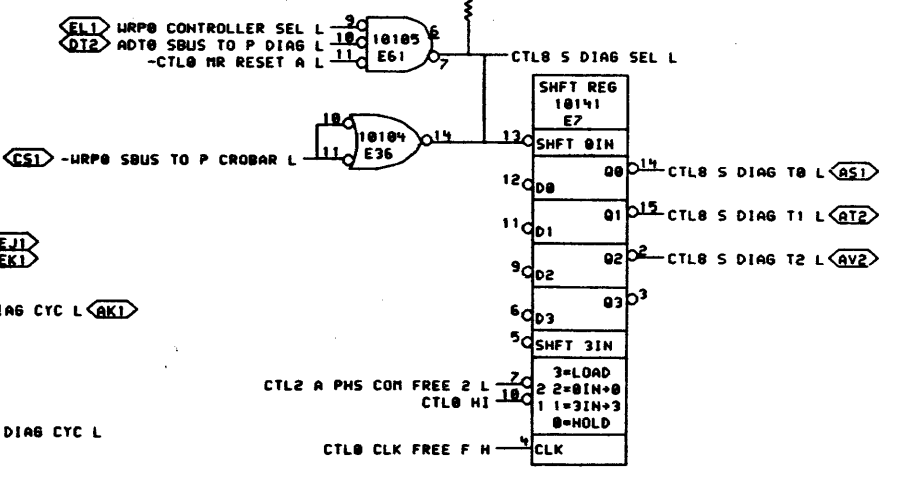
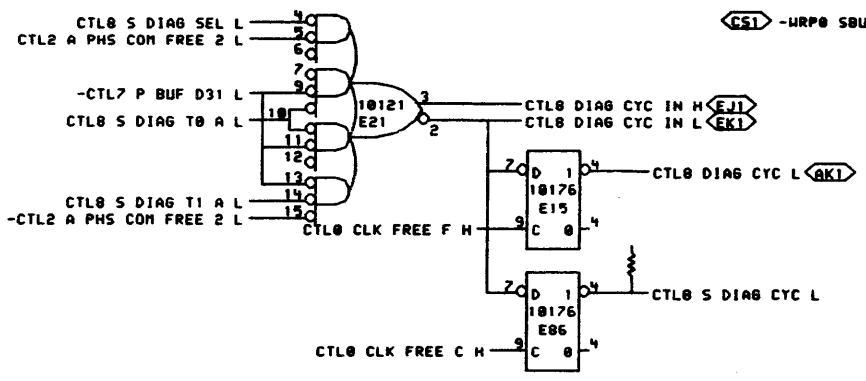
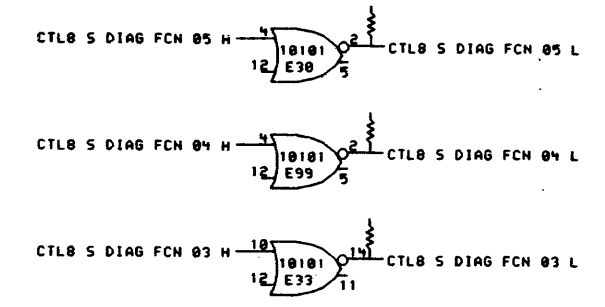
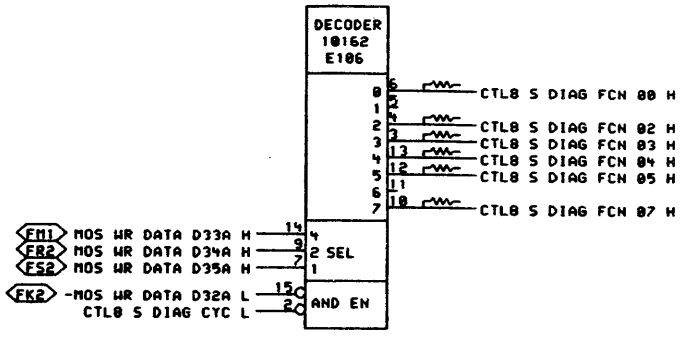
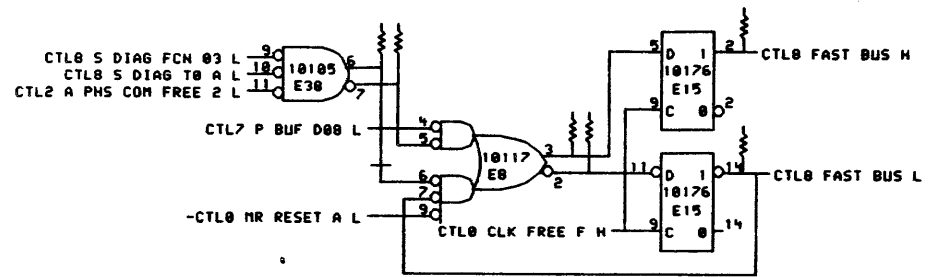

THIS DRAWING AND SPECIFICATIONS ARE THE PROPERTY OF DIGITAL EQUIPMENT CORPORATION AND SHALL NOT BE REPRODUCED OR COPIED OR USED IN WHOLE OR IN PART AS THE BASIS FOR THE MANUFACTURE OR SALE OF ITEMS WITHOUT WRITTEN PERMISSION. COPYRIGHT © 1978, DIGITAL EQUIPMENT CORPORATION.

REV.	CHG.	DATE	BY
1			

REV.	CHG.	DATE	BY
1			

**digital** DRN: P. Luciani, DATE: 28-OCT-78, ENG: Smith, DATE: 11-27-78  
 CHK'D: J. K. Knevel, DATE: 11-27-78, BORD LOCATION: 2AF03  
 PUB: <M8576-MOS>CTL0B.DRW 22-SEP-78 14:31 NEXT HIGHER ASSEMBLY: 1 OF 1 SHEET  
 FIRST USED ON OPTION/MODEL: MF20 D-DD-M8576-0

SIZE	CODE	NUMBER	REV.
D	CS	M8576-0-CTL0	A

REV. A  
 NUMBER M8576-0-CTL0  
 SIZE CODE CS  
 B

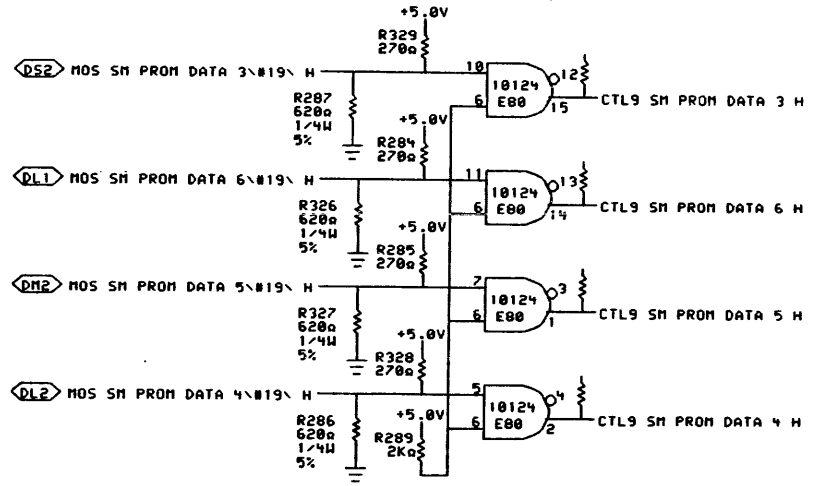
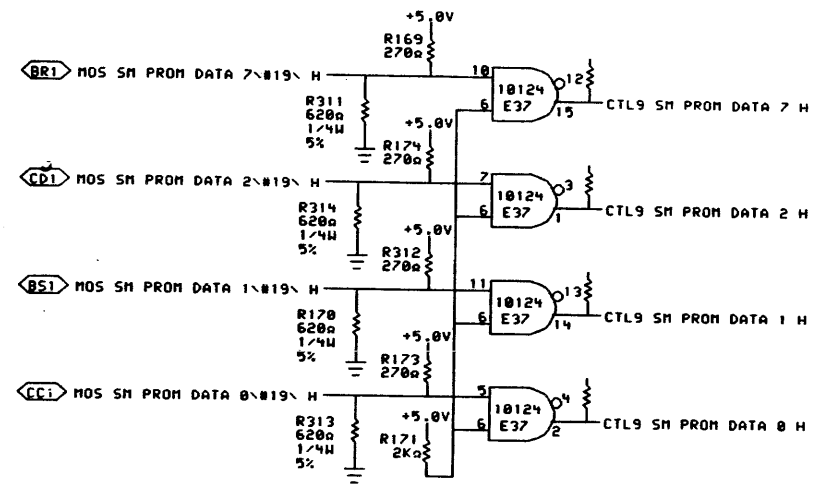
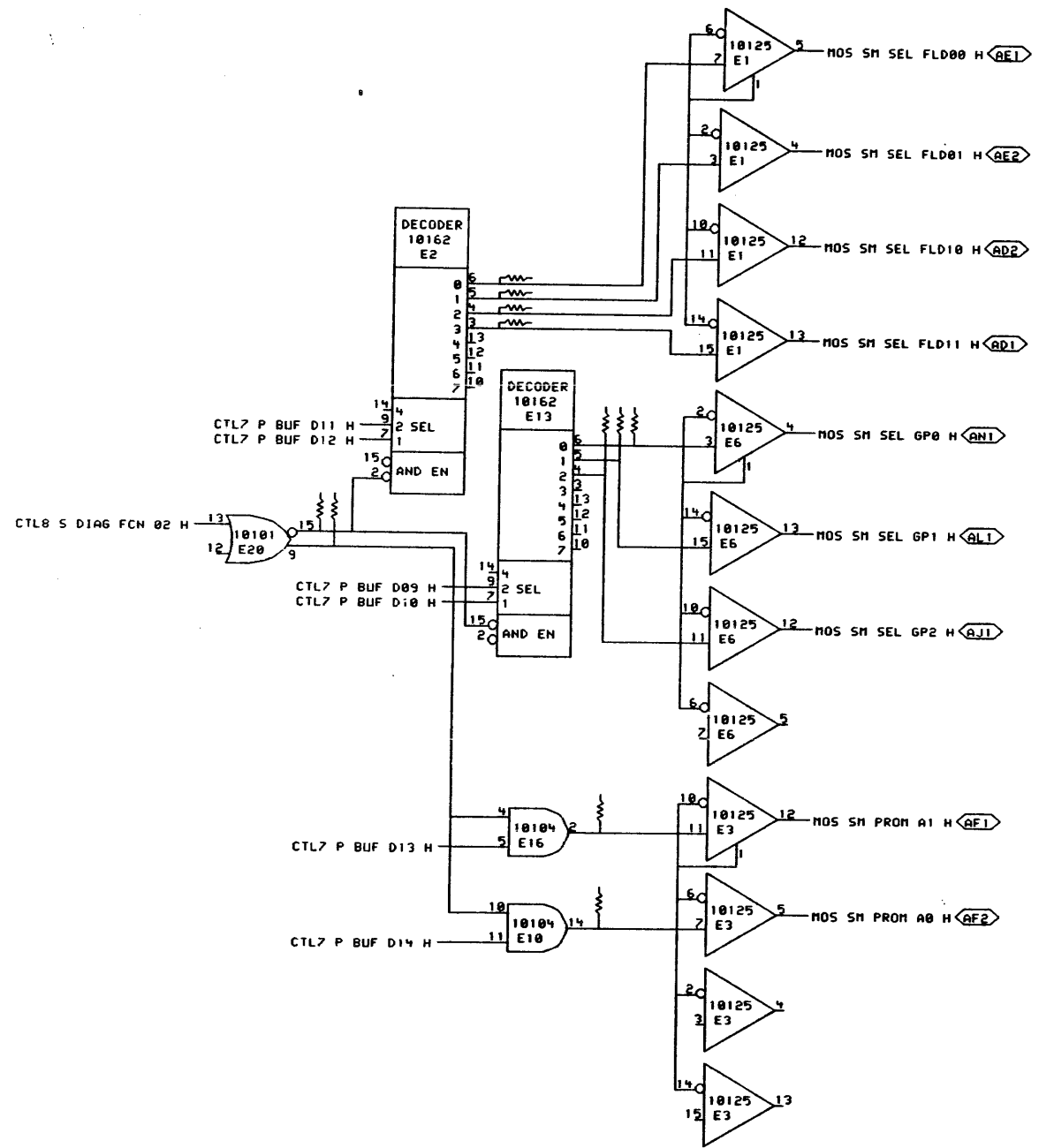

SHEET 10 OF 13

"THIS DRAWING AND SPECIFICATIONS, HEREIN, ARE THE PROPERTY OF DIGITAL EQUIPMENT CORPORATION AND SHALL NOT BE REPRODUCED OR COPIED OR USED IN WHOLE OR IN PART AS THE BASIS FOR THE MANUFACTURE OR SALE OF ITEMS WITHOUT WRITTEN PERMISSION. COPYRIGHT © 1978, DIGITAL EQUIPMENT CORPORATION"

REVISIONS		
CHK	CHANGE NO.	REV

digital	DRN	DATE	ENG.	DATE	TITLE:	MOS CONTROL
	CHK	DATE	BOARD LOCATION:	SAF05	SM PROM CONTROL	REV.
CTL9B.DRW(4,666)		101-MAY-78 10:15	NEXT HIGHER ASSEMBLY:		SIZE	
FIRST USED ON OPTION MODEL:		MF20	D-DD-M8576-0		NUMBER	M8576-0-CTL9

8

7

6

5

4

3

2

9710-3 3/2/84 50 0 3902 3215

1

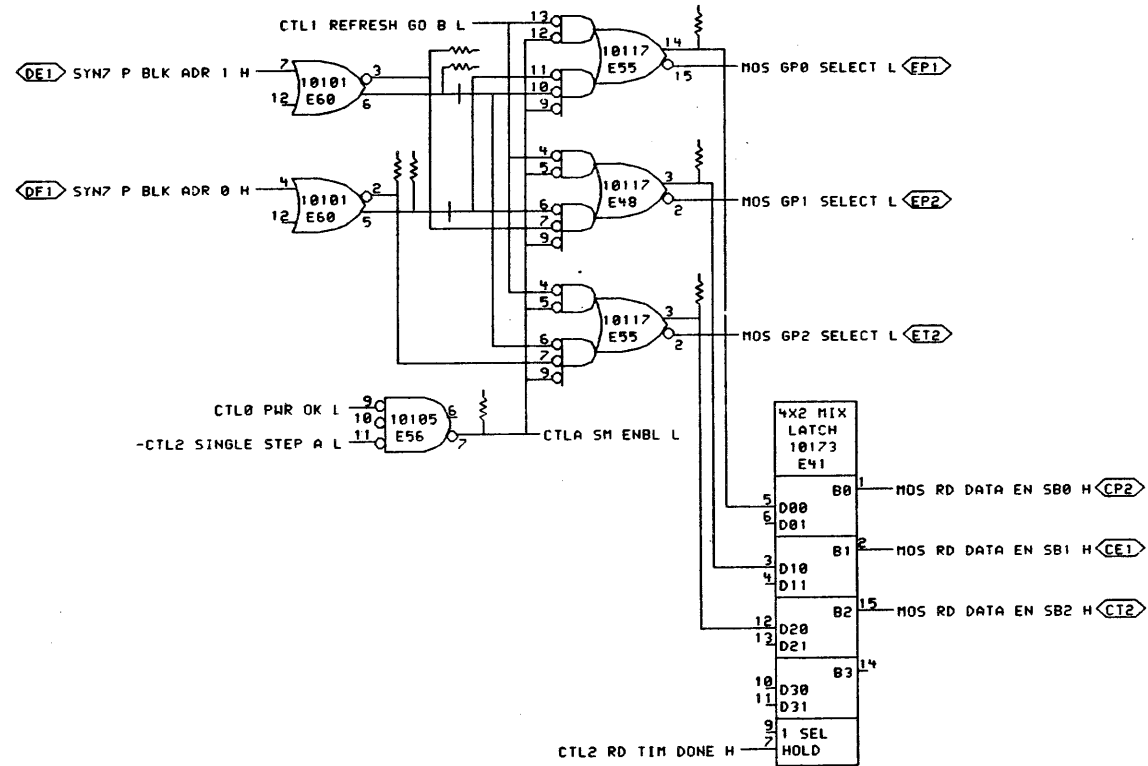

SHEET 11 OF 13

THIS DRAWING AND SPECIFICATIONS, HEREIN, ARE THE PROPERTY OF DIGITAL EQUIPMENT CORPORATION AND SHALL NOT BE REPRODUCED OR COPIED OR USED IN WHOLE OR IN PART AS THE BASIS FOR THE MANUFACTURE OR SALE OF ITEMS WITHOUT WRITTEN PERMISSION.  
 COPYRIGHT © 1978, DIGITAL EQUIPMENT CORPORATION

REVISIONS		
CHK	CHANGE NO.	REV.

	DRN: <i>P. Luciani</i>	DATE: 24-MAR-78	ENG. <i>Alan</i>	DATE: <i>3/2/84</i>	TITLE: MOS CONTROL RAS & SEL DRVR
	CHK'D: <i>P. Luciani</i>	DATE: 27-MAY-78	BOARD LOCATION: 5AF05	SHEET 1 OF 1	SIZE CODE: D CS
CTLAB.DRM 4,666 J		01-MAY-78 10:16	NEXT HIGHER ASSEMBLY: D-DD-M8576-0	NUMBER: M8576-0-CTLA	REV.:
FIRST USED ON OPTION/MODEL: MF20					

8

7

6

5

4

3

2

1

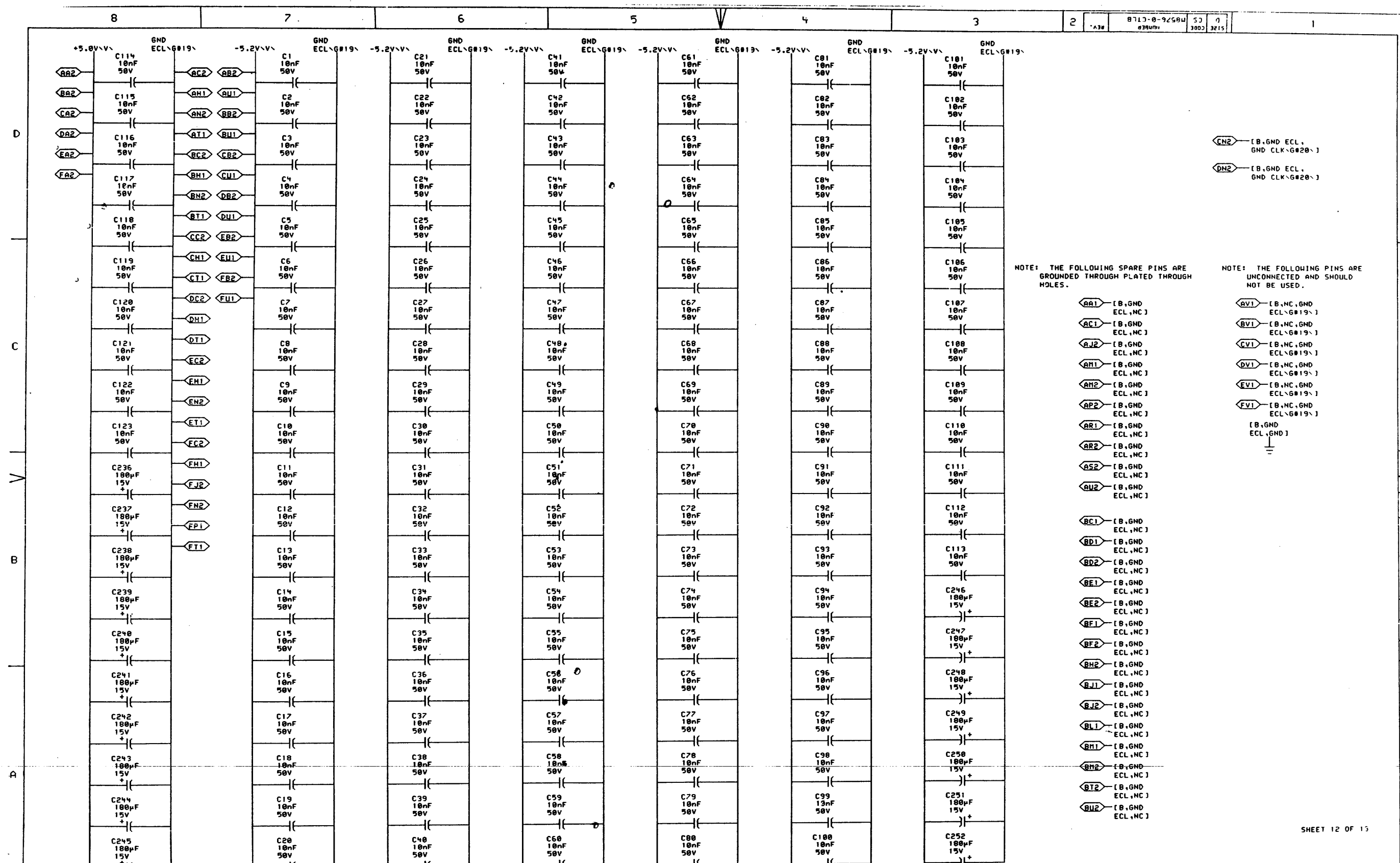

(AA2) [B,GND ECL, GND CLK-G#19]  
 (AB2) [B,GND ECL, GND CLK-G#19]

NOTE: THE FOLLOWING SPARE PINS ARE GROUNDED THROUGH PLATED THROUGH HOLES.

NOTE: THE FOLLOWING PINS ARE UNCONNECTED AND SHOULD NOT BE USED.

- (AA1) [B,GND ECL,NC]
- (AC1) [B,GND ECL,NC]
- (AJ2) [B,GND ECL,NC]
- (AM1) [B,GND ECL,NC]
- (AM2) [B,GND ECL,NC]
- (AP2) [B,GND ECL,NC]
- (AR1) [B,GND ECL,NC]
- (AR2) [B,GND ECL,NC]
- (AS2) [B,GND ECL,NC]
- (AV2) [B,GND ECL,NC]
- (BC1) [B,GND ECL,NC]
- (BD1) [B,GND ECL,NC]
- (BD2) [B,GND ECL,NC]
- (BE1) [B,GND ECL,NC]
- (BE2) [B,GND ECL,NC]
- (BF1) [B,GND ECL,NC]
- (BF2) [B,GND ECL,NC]
- (BH2) [B,GND ECL,NC]
- (BJ1) [B,GND ECL,NC]
- (BJ2) [B,GND ECL,NC]
- (BL1) [B,GND ECL,NC]
- (BM1) [B,GND ECL,NC]
- (BM2) [B,GND ECL,NC]
- (BT2) [B,GND ECL,NC]
- (BU2) [B,GND ECL,NC]

- (AV1) [B,NC,GND ECL-G#19]
- (BV1) [B,NC,GND ECL-G#19]
- (CV1) [B,NC,GND ECL-G#19]
- (DV1) [B,NC,GND ECL-G#19]
- (EV1) [B,NC,GND ECL-G#19]
- (FV1) [B,NC,GND ECL-G#19]
- [B,GND ECL,GND]

REVISIONS		
CHK	CHANGE NO.	REV

	DRN <i>P. Luciani</i>	DATE 25-MAY-78	ENG. <i>Luciani</i>	DATE 25-MAY-78	TITLE: MUS CONTROL POWER. GND. CAPS.
	CHK <i>Luciani</i>	DATE 22-JUN-78	BOARD LOCATION: 5AF05	DATE 22-JUN-78	REV. 1
CTLBB.DRW(4,666)		FIRST USED ON OPTION/MODEL: MF20	NEXT HIGHER ASSEMBLY: D-DD-M8576-0	SIZE CODE D CS	NUMBER M8576-0-CTLB

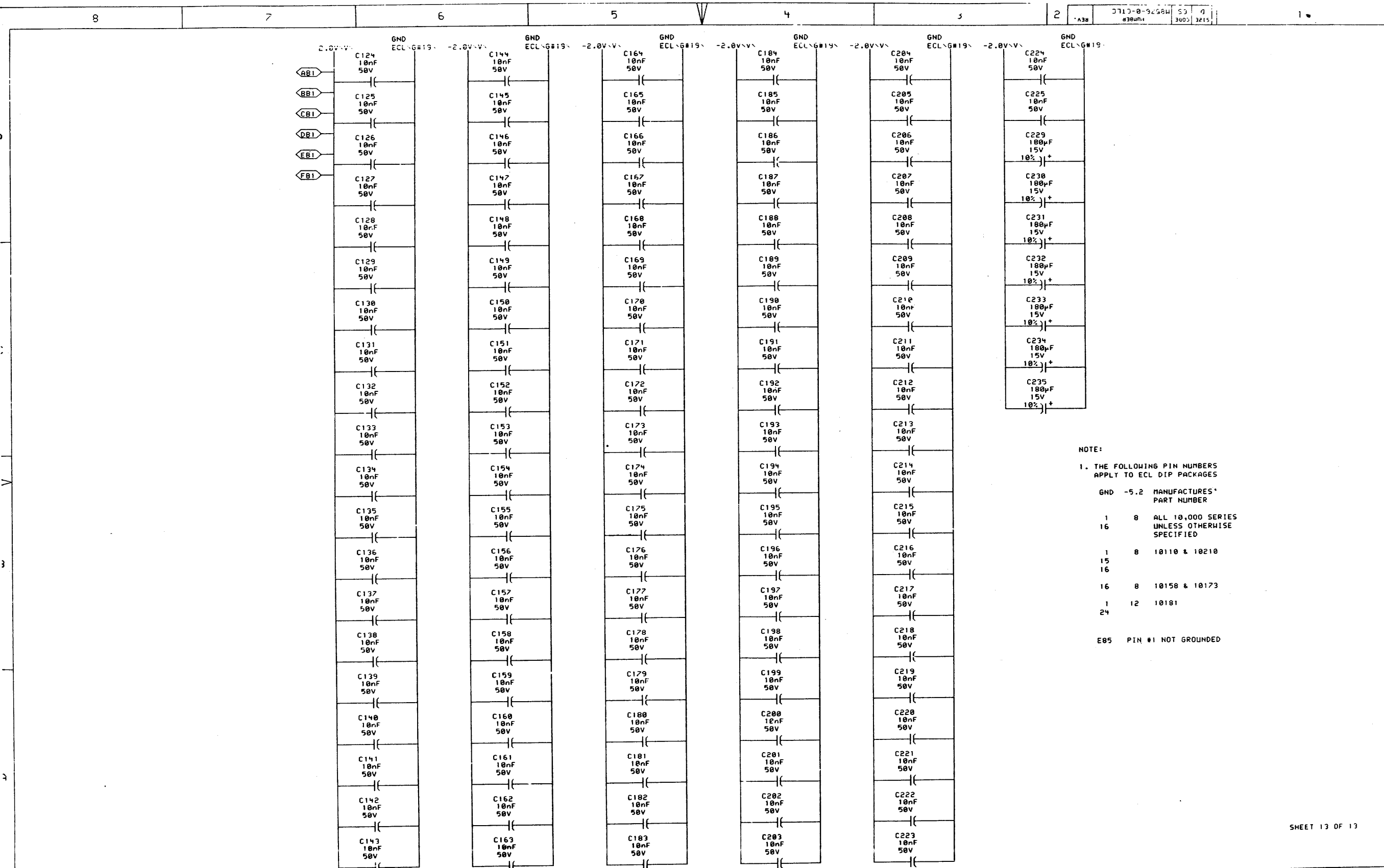

NOTE:  
 1. THE FOLLOWING PIN NUMBERS APPLY TO ECL DIP PACKAGES

GND	-5.2	MANUFACTURERS' PART NUMBER
1	8	ALL 10,000 SERIES UNLESS OTHERWISE SPECIFIED
15	8	10110 & 10210
16	8	10158 & 10173
1	12	10181
24		
E85		PIN #1 NOT GROUNDED

THIS DRAWING AND SPECIFICATIONS, HEREIN, ARE THE PROPERTY OF DIGITAL EQUIPMENT CORPORATION AND SHALL NOT BE REPRODUCED OR COPIED OR USED IN WHOLE OR IN PART AS THE BASIS FOR THE MANUFACTURE OR SALE OF ITEMS WITHOUT WRITTEN PERMISSION. COPYRIGHT © 1978, DIGITAL EQUIPMENT CORPORATION.

REVISIONS		
CHK	CHANGE NO.	REV

**digital** DRN *Lucien* DATE 25-MAY-78 ENG. *Lucien* DATE 25-MAY-78 TITLE: MOS CONTROL POWER. GND. CAPS.

CHG'D BY *Y* DATE 12-MAY-78 BOARD LOCATION: 5AF05 SHEET 1 OF 1

CTLCD, DRN 4, 6663 125-MAY-78 12:46 NEXT HIGHER ASSEMBLY: SIZE CODE NUMBER

FIRST USED ON OPTION/MODEL: MF20 D-DD-M8576-0 D CS M8576-0-CTLCD

RESISTOR LOC(PIN)	SHOWN ON DRUM	REF	VALUE	TERMINATES SIGNAL
R212(1)	CTL9	B6	68 $\Omega$	%E10(14)
R118(1)	CTL3	D3	68 $\Omega$	%E10(15)
R266(1)	CTL3	D3	68 $\Omega$	%E10(9)
R92(1)	CTL6	C6	68 $\Omega$	%E10(2)
R98(1)	CTL6	C6	68 $\Omega$	%E10(3)
R139(1)	CTL1	B5	68 $\Omega$	%E10(2)
R147(1)	CTL1	C6	68 $\Omega$	%E10(2)
R150(1)	CTL1	C6	68 $\Omega$	%E10(2)
R38(1)	CTL6	C4	68 $\Omega$	%E11(14)
R95(1)	CTL6	C4	68 $\Omega$	%E11(15)
R93(1)	CTL6	D3	68 $\Omega$	%E11(2)
R37(1)	CTL6	D4	68 $\Omega$	%E11(3)
R153(1)	CTL1	D6	68 $\Omega$	%E11(5)
R148(1)	CTL1	D6	68 $\Omega$	%E11(3)
R97(1)	CTL6	D6	68 $\Omega$	%E11(2)
R143(1)	CTL6	D6	68 $\Omega$	%E11(3)
R209(1)	CTL1	D7	68 $\Omega$	%E11(14)
R205(1)	CTL1	D7	68 $\Omega$	%E11(3)
R302(1)	CTL9	C6	68 $\Omega$	%E13(4)
R304(1)	CTL9	C6	68 $\Omega$	%E13(5)
R303(1)	CTL9	C6	68 $\Omega$	%E13(6)
R220(1)	CTL0	B3	68 $\Omega$	%E14(2)
R217(1)	CTL0	B3	68 $\Omega$	%E15(3)
R213(1)	CTL9	B6	68 $\Omega$	%E16(2)
R43(1)	CTL5	B7	68 $\Omega$	%E18(1)
R102(1)	CTL5	B7	68 $\Omega$	%E18(14)
R160(1)	CTL5	B7	68 $\Omega$	%E18(15)
R44(1)	CTL5	B7	68 $\Omega$	%E18(2)
R19(1)	CTL9	B4	68 $\Omega$	%E19(2)
R290(1)	CTL9	C7	68 $\Omega$	%E2(3)
R301(1)	CTL9	C7	68 $\Omega$	%E2(4)
R299(1)	CTL9	C7	68 $\Omega$	%E2(5)
R300(1)	CTL9	C7	68 $\Omega$	%E2(6)
R255(1)	CTL9	C7	68 $\Omega$	%E20(15)
R106(1)	CTL9	C7	68 $\Omega$	%E20(9)
R13(1)	CTL3	C5	68 $\Omega$	%E24(15)
R50(1)	CTL4	C4	68 $\Omega$	%E25(13)
R11(1)	CTL4	B4	68 $\Omega$	%E26(15)
R10(1)	CTL4	B4	68 $\Omega$	%E26(2)
R275(1)	CTL1	B4	68 $\Omega$	%E27(1)

RESISTOR LOC(PIN)	SHOWN ON DRUM	REF	VALUE	TERMINATES SIGNAL
R270(1)	CTL1	B4	68 $\Omega$	%E27(14)
R260(1)	CTL1	B4	68 $\Omega$	%E27(15)
R273(1)	CTL1	B4	68 $\Omega$	%E27(2)
R123(1)	CTL6	A7	68 $\Omega$	%E28(15)
R225(1)	CTL7	A3	68 $\Omega$	%E28(2)
R214(1)	CTL7	A2	68 $\Omega$	%E29(15)
R14(1)	CTL3	B4	68 $\Omega$	%E33(15)
R22(1)	CTL3	A4	68 $\Omega$	%E33(5)
R271(1)	CTL1	B3	68 $\Omega$	%E35(15)
R110(1)	CTL6	A2	68 $\Omega$	%E38(15)
R216(1)	CTL0	C7	68 $\Omega$	%E38(6)
R210(1)	CTL0	C7	68 $\Omega$	%E38(7)
R17(1)	CTL1	C6	68 $\Omega$	%E40(14)
R24(1)	CTL1	B6	68 $\Omega$	%E40(15)
R61(1)	CTL3	B7	68 $\Omega$	%E40(2)
R16(1)	CTL3	C2	68 $\Omega$	%E46(14)
R10(1)	CTL3	C2	68 $\Omega$	%E46(15)
R25(1)	CTL2	C7	68 $\Omega$	%E46(3)
R315(1)	CTLA	C4	68 $\Omega$	%E48(3)
R127(1)	CTL1	D7	68 $\Omega$	%E50(15)
R335(1)	CTL0	A5	68 $\Omega$	%E50(2)
R100(1)	CTL3	C6	68 $\Omega$	%E53(15)
R20(1)	CTL3	C5	68 $\Omega$	%E54(13)
R317(1)	CTLA	C4	68 $\Omega$	%E55(14)
R316(1)	CTLA	C4	68 $\Omega$	%E55(3)
R53(1)	CTL4	C6	68 $\Omega$	%E58(14)
R54(1)	CTL4	C6	68 $\Omega$	%E58(15)
R52(1)	CTL4	C6	68 $\Omega$	%E58(2)
R322(1)	CTLA	C5	68 $\Omega$	%E60(2)
R320(1)	CTLA	C5	68 $\Omega$	%E60(3)
R310(1)	CTLA	C5	68 $\Omega$	%E60(5)
R321(1)	CTLA	C5	68 $\Omega$	%E60(6)
R72(1)	CTL6	B5	68 $\Omega$	%E61(15)
R67(1)	CTL4	C7	68 $\Omega$	%E64(2)
R84(1)	CTL5	B3	68 $\Omega$	%E69(15)
R202(1)	CTL2	A3	68 $\Omega$	%E69(3)
R237(1)	CTL2	A3	68 $\Omega$	%E69(6)
R201(1)	CTL2	A3	68 $\Omega$	%E69(7)
R207(1)	CTL1	D6	68 $\Omega$	%E71(14)
R23(1)	CTL4	A5	68 $\Omega$	%E72(14)

RESISTOR LOC(PIN)	SHOWN ON DRUM	REF	VALUE	TERMINATES SIGNAL
R30(1)	CTL6	A2	68 $\Omega$	%E73(14)
R60(1)	CTL2	C7	68 $\Omega$	%E73(7)
R330(1)	CTL2	B1	68 $\Omega$	%E74(14)
R331(1)	CTL2	B1	68 $\Omega$	%E74(15)
R81(1)	CTL3	A6	68 $\Omega$	%E76(2)
R65(1)	CTL6	B5	68 $\Omega$	%E77(14)
R247(1)	CTL1	B6	68 $\Omega$	%E77(15)
R66(1)	CTL6	A5	68 $\Omega$	%E77(3)
R27(1)	CTL3	B4	68 $\Omega$	%E78(14)
R80(1)	CTL3	C4	68 $\Omega$	%E78(2)
R21(1)	CTL3	B4	68 $\Omega$	%E78(3)
R325(1)	CTL0	C4	68 $\Omega$	%E79(12)
R215(1)	CTL0	C6	68 $\Omega$	%E8(2)
R219(1)	CTL0	C6	68 $\Omega$	%E8(3)
R76(1)	CTL6	B5	68 $\Omega$	%E83(15)
R79(1)	CTL6	A5	68 $\Omega$	%E83(2)
R26(1)	CTL6	A2	68 $\Omega$	%E84(3)
R345(1)	CTL4	B5	68 $\Omega$	%E84(4)
R02(1)	CTL2	D6	68 $\Omega$	%E90(15)
R122(1)	CTL1	B5	68 $\Omega$	%E91(13)
R70(1)	CTL4	A2	68 $\Omega$	%E91(4)
R90(1)	CTL5	C4	68 $\Omega$	%E95(14)
R07(1)	CTL5	C4	68 $\Omega$	%E95(2)
R05(1)	CTL5	C4	68 $\Omega$	%E95(15)
R33(1)	CTL5	C3	68 $\Omega$	%E96(15)
R32(1)	CTL5	C3	68 $\Omega$	%E96(2)
R23(1)	CTL5	C3	68 $\Omega$	%E96(3)
R31(1)	CTL5	C2	68 $\Omega$	%E97(15)
R34(1)	CTL5	C2	68 $\Omega$	%E97(2)
R74(1)	CTL6	B4	68 $\Omega$	-ADT0 SBUS TO P DIAG H
R142(1)	CTL2	D7	68 $\Omega$	ADT3 INC RQ ERR+1 H
R141(1)	CTL2	D7	68 $\Omega$	-ADT3 TIMRAN BSY CLR A H
R129(1)	CTL2	C7	68 $\Omega$	-ADT4 TIM DATA RDY H
R306(1)	CTL1	A0	68 $\Omega$	ADT5 REFRESH 60 H
R240(1)	CTL1	B6	68 $\Omega$	-ADT5 REFRESH 60 IN H
R124(1)	CTL1	A5	68 $\Omega$	ADT5 REFRESH 60+3 H
R176(1)	CTL1	D7	68 $\Omega$	ADT5 REFRESH NON H
R233(1)	CTL0	B7	68 $\Omega$	ADT6 CLK FREE 02-020\ H
R239(1)	CTL0	C7	68 $\Omega$	ADT6 CLK GATED 12\020\ H
R130(1)	CTL2	C7	68 $\Omega$	-ADT7 BUX SELECT EN IN H

RESISTOR LOC(PIN)	SHOWN ON DRUM	REF	VALUE	TERMINATES SIGNAL
R234(1)	CTL0	C6	68 $\Omega$	CTL0 CLK FREE A H
R235(1)	CTL0	C6	68 $\Omega$	CTL0 CLK FREE B H
R333(1)	CTL0	C6	68 $\Omega$	CTL0 CLK FREE C H
R180(1)	CTL0	B6	68 $\Omega$	CTL0 CLK FREE D H
R181(1)	CTL0	B6	68 $\Omega$	CTL0 CLK FREE E H
R257(1)	CTL0	B6	68 $\Omega$	CTL0 CLK FREE F H
R94(1)	CTL0	C6	68 $\Omega$	CTL0 CLK GATED A H
R240(1)	CTL0	C6	68 $\Omega$	CTL0 CLK GATED B H
R241(1)	CTL0	C6	68 $\Omega$	CTL0 CLK GATED C H
R09(1)	CTL0	C6	68 $\Omega$	CTL0 CLK GATED D H
R15(1)	CTL0	C6	68 $\Omega$	CTL0 CLK GATED E H
R12(1)	CTL0	C6	68 $\Omega$	CTL0 CLK GATED F H
R134(1)	CTL0	B4	68 $\Omega$	-CTL0 DATA VALID A IN H
R131(1)	CTL0	A4	68 $\Omega$	-CTL0 DATA VALID B IN H
R246(1)	CTL0	A6	68 $\Omega$	CTL0 HI
R332(1)	CTL0	B6	68 $\Omega$	CTL0 HI A
R277(1)	CTL0	B2	68 $\Omega$	CTL0 MR RESET A H
R258(1)	CTL0	B4	68 $\Omega$	CTL0 MR RESET B H
R256(1)	CTL0	A5	68 $\Omega$	-CTL0 PWR OK H
R244(1)	CTL0	C4	68 $\Omega$	CTL0 SBUS TO P ADR 34 H
R245(1)	CTL0	C4	68 $\Omega$	CTL0 SBUS TO P ADR 35 H
R190(1)	CTL0	C1	68 $\Omega$	CTL0 SBUS TO P RD R0 H
R274(1)	CTL0	D1	68 $\Omega$	CTL0 SBUS TO P RD 0 H
R276(1)	CTL0	D1	68 $\Omega$	CTL0 SBUS TO P RD 1 H
R267(1)	CTL0	D1	68 $\Omega$	CTL0 SBUS TO P RD 2 H
R272(1)	CTL0	C1	68 $\Omega$	CTL0 SBUS TO P RD 3 H
R291(1)	CTL0	C4	68 $\Omega$	CTL0 SBUS TO P SBUS CLK H
R204(1)	CTL0	C1	68 $\Omega$	CTL0 SBUS TO P START A H
R203(1)	CTL0	B1	68 $\Omega$	CTL0 SBUS TO P START B H
R201(1)	CTL0	C1	68 $\Omega$	CTL0 SBUS TO P MR R0 H
R135(1)	CTL1	C5	68 $\Omega$	CTL1 A PHS START H
R59(1)	CTL1	D5	68 $\Omega$	-CTL1 A PHS START H
R133(1)	CTL1	C5	68 $\Omega$	CTL1 B PHS START H
R62(1)	CTL1	C5	68 $\Omega$	-CTL1 B PHS START H
R206(1)	CTL1	C2	68 $\Omega$	CTL1 DIAG START A H
R202(1)	CTL1	C2	68 $\Omega$	CTL1 DIAG START B H
R1(1)	CTL1	A2	68 $\Omega$	CTL1 P ADR 34 H
R40(1)	CTL1	A2	68 $\Omega$	CTL1 P ADR 35 H
R130(1)	CTL1	C1	68 $\Omega$	CTL1 P RD R0 A H
R114(1)	CTL1	C1	68 $\Omega$	-CTL1 P RD R0 A H

NOTE:

1. ALL TERMINATORS HAVE PIN TWO CONNECTED TO -2.0V AND ARE 5% 1/4WATT UNLESS OTHERWISE SPECIFIED
2. ENTRIES ARE SORTED BY SIGNAL NAME
3. % INDICATES OUTPUT OF DIP LOC AND ( ) INDICATES PIN NUMBER

REVISIONS	CHK	CHANGE NO.	REV
1	CS	1552	A
2	CS	1552	B

DATE	ENG	DATE	TITLE
20-OCT-78	Smith	19-10-78	MOS CONTROL TERMINATORS
DATE	BOARD LOCATION	DATE	SHEET
12-OCT-78	1	12-OCT-78	1
DATE	BOARD LOCATION	DATE	SHEET
12-OCT-78	1	12-OCT-78	1

**digital** DRN. *G. Smith* DATE 20-OCT-78 ENG. *G. Smith* DATE 19-10-78 TITLE: MOS CONTROL TERMINATORS  
 CHK'D BY *Mr. M. M. M.* BOARD LOCATION: 1 SHEET OF 2  
 PUB: (M8576-MOS)M8576.1.DRW 12-OCT-78 10:29 NEXT HIGHER ASSEMBLY:  
 FIRST USED ON OPTION/MODEL: MF20 B-DD-M8576-0 SIZE CODE NUMBER REV. D CS M8576-0-RES A

REV. A  
 SIZE CODE NUMBER M8576-0-RES

RESISTOR LOC(PIN)	SHOWN DRW#	ON REF	VALUE	TERMINATES SIGNAL	RESISTOR LOC(PIN)	SHOWN DRW#	ON REF	VALUE	TERMINATES SIGNAL	RESISTOR LOC(PIN)	SHOWN DRW#	ON REF	VALUE	TERMINATES SIGNAL	RESISTOR LOC(PIN)	SHOWN DRW#	ON REF	VALUE	TERMINATES SIGNAL
R100(1)	CTL1	C2	60a	CTL1 P RD 0 H	R136(1)	CTL2	B2	60a	-CTL2 SINGLE STEP A H	R117(1)	CTL6	B6	60a	-CTL6 ACKN B PHS START H	R259(1)	CTL7	A5	60a	CTL7 P BUF D31 H
R101(1)	CTL1	B2	60a	CTL1 P RD 1 H	R167(1)	CTL2	A6	60a	CTL2 START CLR H	R151(1)	CTL6	D3	60a	CTL6 B PHS DATA VALID H	R168(1)	CTL8	C6	60a	CTL8 FAST BUS H
R158(1)	CTL1	B2	60a	CTL1 P RD 2 H	R152(1)	CTL2	A6	60a	CTL2 START CLR DLY H	R330(1)	CTL6	D3	60a	-CTL6 B PHS DATA VALID H	R96(1)	CTL8	C6	60a	-CTL8 FAST BUS H
R159(1)	CTL1	B2	60a	CTL1 P RD 3 H	R20(1)	CTL2	A7	60a	CTL2 START CLR IN H	R184(1)	CTL6	D5	60a	-CTL6 B PHS RD DATA OUT H	R295(1)	CTL8	B6	60a	-CTL8 S DIAG CYC H
R6(1)	CTL1	C2	60a	CTL1 P MR RD H	R200(1)	CTL2	A7	60a	-CTL2 START CLR IN H	R55(1)	CTL6	D3	60a	CTL6 DATA VALID OUT H	R223(1)	CTL8	C4	60a	CTL8 S DIAG FCN 00 H
R7(1)	CTL1	C1	60a	-CTL1 P MR RD H	R140(1)	CTL3	B7	60a	-CTL3 DATA VALID IN EN H	R126(1)	CTL6	D3	60a	-CTL6 DATA VALID OUT H	R307(1)	CTL8	C4	60a	CTL8 S DIAG FCN 02 H
R120(1)	CTL1	C5	60a	CTL1 RAS START 0 H	R03(1)	CTL3	C4	60a	-CTL3 ERR MD NUM T1 H	R5(1)	CTL6	C2	60a	-CTL6 DATA VALID OUT DLY H	R4(1)	CTL8	C4	60a	CTL8 S DIAG FCN 03 H
R9(1)	CTL1	C4	60a	-CTL1 RAS START 0 A H	R0(1)	CTL3	A6	60a	-CTL3 P DATA VALID IN H	R50(1)	CTL6	C2	60a	-CTL6 RD START CLR EN H	R115(1)	CTL8	C2	60a	-CTL8 S DIAG FCN 03 H
R36(1)	CTL1	A7	60a	-CTL1 RD 1ST HALF H	R155(1)	CTL3	B3	60a	CTL3 P MR ADR 34 H	R49(1)	CTL7	A2	60a	-CTL7 ACKN RAM MR PLS H	R293(1)	CTL8	C4	60a	CTL8 S DIAG FCN 04 H
R350(1)	CTL1	A7	60a	CTL1 REFRESH 60 B H	R156(1)	CTL3	B3	60a	CTL3 P MR ADR 35 H	R41(1)	CTL7	B2	60a	-CTL7 D VAL RAM MR PLS H	R296(1)	CTL8	C2	60a	-CTL8 S DIAG FCN 04 H
R346(1)	CTL1	A7	60a	-CTL1 REFRESH 60 B H	R179(1)	CTL3	C4	60a	-CTL3 MR DATA NOV T1 H	R45(1)	CTL7	C5	60a	CTL7 DIAG ADR 0 H	R310(1)	CTL8	C4	60a	CTL8 S DIAG FCN 05 H
R119(1)	CTL1	B6	60a	-CTL1 RPW END HALF H	R347(1)	CTL3	D2	60a	CTL3 MR DATA NOV TIM 60 H	R71(1)	CTL7	B5	60a	CTL7 DIAG ADR 1 H	R265(1)	CTL8	C2	60a	-CTL8 S DIAG FCN 05 H
R264(1)	CTL2	B1	60a	CTL2 A PHS H	R57(1)	CTL3	C2	60a	-CTL3 MR DATA NOV TIM 60 H	R300(1)	CTL7	B5	60a	CTL7 DIAG ADR 2 H	R111(1)	CTL8	C4	60a	CTL8 S DIAG FCN 07 H
R69(1)	CTL2	C1	60a	-CTL2 A PHS COM FREE 1 H	R340(1)	CTL4	D4	60a	-CTL4 A PHS ACKN H	R210(1)	CTL7	B5	60a	CTL7 DIAG ADR 3 H	R254(1)	CTL8	B4	60a	-CTL8 S DIAG SEL H
R261(1)	CTL2	C1	60a	CTL2 A PHS COM FREE 2 H	R337(1)	CTL4	D4	60a	-CTL4 B PHS ACKN H	R221(1)	CTL7	B5	60a	CTL7 DIAG ADR 4 H	R236(1)	CTL8	C2	60a	-CTL8 S DIAG T0 A H
R116(1)	CTL2	C1	60a	-CTL2 A PHS COM FREE 2 H	R292(1)	CTL4	C2	60a	CTL4 ERR ADR 34 H	R224(1)	CTL7	B5	60a	CTL7 DIAG ADR 5 H	R263(1)	CTL8	B2	60a	CTL8 S DIAG T1 A H
R229(1)	CTL2	C1	60a	-CTL2 A PHS COMING 1 H	R249(1)	CTL4	C2	60a	CTL4 ERR ADR 35 H	R64(1)	CTL7	B5	60a	CTL7 DIAG ADR 6 H	R68(1)	CTL8	B2	60a	-CTL8 S DIAG T1 A H
R40(1)	CTL2	B4	60a	-CTL2 A PHS COMING 2 H	R195(1)	CTL4	D2	60a	CTL4 ERR RD RD H	R63(1)	CTL7	A5	60a	CTL7 DIAG ADR 7 H	R262(1)	CTL8	B2	60a	CTL8 S DIAG T2 H
R154(1)	CTL2	B4	60a	CTL2 A PHS COMING A H	R165(1)	CTL4	C2	60a	CTL4 ERR RD 0 H	R226(1)	CTL7	A2	60a	-CTL7 DIAG CYC RD HLD H	R175(1)	CTL9	C3	60a	CTL9 SM PROM DATA 0 H
R125(1)	CTL2	B4	60a	-CTL2 A PHS COMING A H	R178(1)	CTL4	B2	60a	CTL4 ERR RD 1 H	R162(1)	CTL7	C7	60a	-CTL7 DIAG DATA EN H	R164(1)	CTL9	C3	60a	CTL9 SM PROM DATA 1 H
R269(1)	CTL2	B2	60a	-CTL2 A PHS-1 H	R126(1)	CTL4	B2	60a	CTL4 ERR RD 2 H	R197(1)	CTL7	D7	60a	CTL7 DIAG SEL 1 H	R172(1)	CTL9	C3	60a	CTL9 SM PROM DATA 2 H
R270(1)	CTL2	B1	60a	CTL2 B PHS H	R103(1)	CTL4	B2	60a	CTL4 ERR RD 3 H	R193(1)	CTL7	D7	60a	CTL7 DIAG SEL 2 H	R182(1)	CTL9	B3	60a	CTL9 SM PROM DATA 3 H
R230(1)	CTL2	C3	60a	-CTL2 B PHS COMING 1 H	R77(1)	CTL4	B2	60a	-CTL4 ERR T2 H	R194(1)	CTL7	D7	60a	CTL7 DIAG SEL 4 H	R190(1)	CTL9	B3	60a	CTL9 SM PROM DATA 4 H
R39(1)	CTL2	C4	60a	-CTL2 B PHS COMING 2 H	R227(1)	CTL4	B4	60a	CTL4 ERR MD NUM 1 H	R199(1)	CTL7	B7	60a	CTL7 P BUF D06 H	R192(1)	CTL9	B3	60a	CTL9 SM PROM DATA 5 H
R149(1)	CTL2	B4	60a	CTL2 B PHS COMING A H	R161(1)	CTL4	C4	60a	CTL4 ERR MD NUM 2 H	R200(1)	CTL7	B7	60a	CTL7 P BUF D07 H	R187(1)	CTL9	B3	60a	CTL9 SM PROM DATA 6 H
R120(1)	CTL2	B4	60a	-CTL2 B PHS COMING A H	R180(1)	CTL4	D2	60a	CTL4 ERR MR RD H	R309(1)	CTL7	B7	60a	CTL7 P BUF D08 H	R157(1)	CTL9	D3	60a	CTL9 SM PROM DATA 7 H
R279(1)	CTL2	B2	60a	-CTL2 B PHS-1 H	R2(1)	CTL4	A1	60a	-CTL4 LD ERR MD NUM H	R211(1)	CTL7	B7	60a	-CTL7 P BUF D08 H	R319(1)	CTLA	B5	60a	-CTLA SM ENBL H
R35(1)	CTL2	C6	60a	-CTL2 DATA RDT H	R105(1)	CTL4	D5	60a	-CTL4 P ACKN EN H	R305(1)	CTL7	B7	60a	CTL7 P BUF D09 H	R232(1)	CTL1	D7	60a	-SYN7 BOX SELECT H
R137(1)	CTL2	A7	60a	CTL2 ERR RESET H	R230(1)	CTL5	B3	60a	-CTL5 LD RD DATA NOV H	R200(1)	CTL7	B7	60a	-CTL7 P BUF D09 H	R06(1)	CTL4	B2	60a	SYN7 ERR ADR HOLD H
R00(1)	CTL2	A7	60a	-CTL2 ERR RESET H	R103(1)	CTL5	C2	60a	CTL5 P RD ADR 34 H	R51(1)	CTL7	B7	60a	CTL7 P BUF D10 H	R75(1)	CTL6	B4	60a	-WRP0 CONTROLLER SEL H
R222(1)	CTL2	C6	60a	CTL2 P ADR HOLD H	R196(1)	CTL5	B5	60a	CTL5 P RD ADR 34 RAM H	R203(1)	CTL7	B7	60a	-CTL7 P BUF D10 H	R220(1)	CTL1	D7	60a	WRP0 SBUS TO P CROBAR H
R177(1)	CTL2	A4	60a	-CTL2 PHS COMING 1 H	R104(1)	CTL5	C2	60a	CTL5 P RD ADR 35 H	R103(1)	CTL7	B7	60a	CTL7 P BUF D11 H	R70(1)	CTL6	A7	60a	WRP4 S DIAG PT LPBK H
R231(1)	CTL2	B6	60a	CTL2 RAS START IMM B H	R145(1)	CTL5	B5	60a	CTL5 P RD ADR 35 RAM H	R132(1)	CTL7	B7	60a	-CTL7 P BUF D11 H	R73(1)	CTL4	A5	60a	WRP0 SUB RAM PAR OK H
R163(1)	CTL2	D5	60a	-CTL2 RD BUSTY CLR SEEN H	R144(1)	CTL5	B6	60a	CTL5 SET DATA VAL RAM H	R42(1)	CTL7	A7	60a	CTL7 P BUF D12 H					
R3(1)	CTL2	C5	60a	CTL2 RD TIM DONE H	R103(1)	CTL5	C2	60a	CTL5 SET DATA VALID H	R46(1)	CTL7	A7	60a	CTL7 P BUF D13 H					
R324(1)	CTL2	D5	60a	-CTL2 RD TIM DONE H	R91(1)	CTL5	C2	60a	-CTL5 SET DATA VALID H	R105(1)	CTL7	A7	60a	CTL7 P BUF D14 H					
R99(1)	CTL2	D6	60a	-CTL2 RD TIM DONE IM H	R146(1)	CTL6	C3	60a	CTL6 A PHS DATA VALID H	R113(1)	CTL7	A7	60a	-CTL7 P BUF D14 H					
R297(1)	CTL2	A2	60a	-CTL2 SIN A PHS COM H	R336(1)	CTL6	C3	60a	-CTL6 A PHS DATA VALID H	R112(1)	CTL7	A7	60a	-CTL7 P BUF D15 H					
R294(1)	CTL2	A2	60a	-CTL2 SIN B PHS COM H	R191(1)	CTL6	C5	60a	-CTL6 A PHS RD DATA OUT H	R47(1)	CTL7	A5	60a	CTL7 P BUF D26 H					
R260(1)	CTL2	B2	60a	CTL2 SINGLE STEP A H	R121(1)	CTL6	B6	60a	-CTL6 ACKN A PHS START H	R107(1)	CTL7	A5	60a	CTL7 P BUF D27 H					

NOTE:  
 1. ALL TERMINATORS HAVE PIN TWO CONNECTED TO -2.0V AND ARE 5% 1/4WATT UNLESS OTHERWISE SPECIFIED  
 2. ENTRIES ARE SORTED BY SIGNAL NAME  
 3. % INDICATES OUTPUT OF DIP LOC AND ( ) INDICATES PIN NUMBER

REV. NO.	DATE	DESCRIPTION
1	11/19/78	INITIAL DESIGN
2	12/12/78	REVISED TO INCLUDE BOARD LOCATION
3	1/12/79	REVISED TO INCLUDE BOARD LOCATION
4	2/12/79	REVISED TO INCLUDE BOARD LOCATION

	DRN. <u>G. Smith</u>	DATE <u>11-19-78</u>	ENG. <u>[Signature]</u>	DATE <u>1/12/79</u>	TITLE: <b>MOS CONTROL TERMINATORS</b>
	CHK'D <u>[Signature]</u>	DATE <u>11-19-78</u>	BOARD LOCATION: <u>2</u>	SHEET <u>2</u> OF <u>2</u>	SIZE CODE: <b>D CS M8576-0-RES</b>
FIRST USED ON OPTION/MODEL: <b>HF20</b>				NEXT HIGHER ASSEMBLY: <b>B-DD-M8576-0</b>	

REV. A  
 NUMBER M8576-0-RES  
 SIZE CODE D CS  
 B  
 A





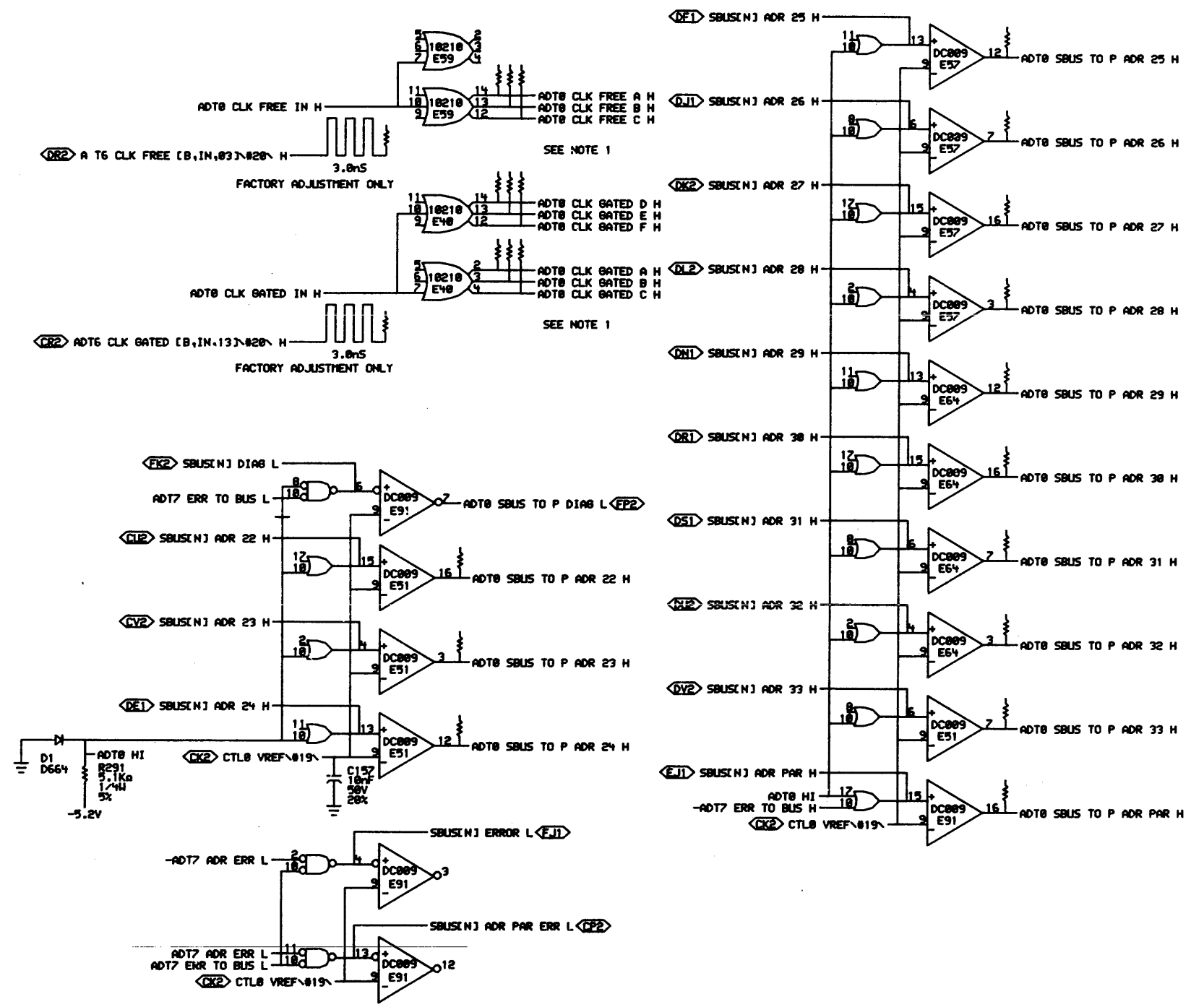

SHEET 1 OF 12

THIS DRAWING AND SPECIFICATIONS  
HEREIN ARE THE PROPERTY OF  
DIGITAL EQUIPMENT CORPORATION AND  
SHALL NOT BE REPRODUCED OR COPIED  
OR USED IN WHOLE OR IN PART AS  
THE BASIS FOR THE MANUFACTURE OR  
SALE OF ITEMS WITHOUT WRITTEN  
PERMISSION. COPYRIGHT © 1978,  
DIGITAL EQUIPMENT CORPORATION

REVISIONS	
CHK	CHANGE NO. REV

digital

DATE 11-22-78

ENG. D.J. Chin

DATE 7-18-78

BOARD LOCATION 5E02

TITLE: ADDRESS AND TIME PORT ADR INTER

SIZE CODE NUMBER REV.

D CS M8577-0-ADT0

FIRST USED ON OPTION/MODEL: MF20

NEXT HIGHER ASSEMBLY: D-DD-M8577-0

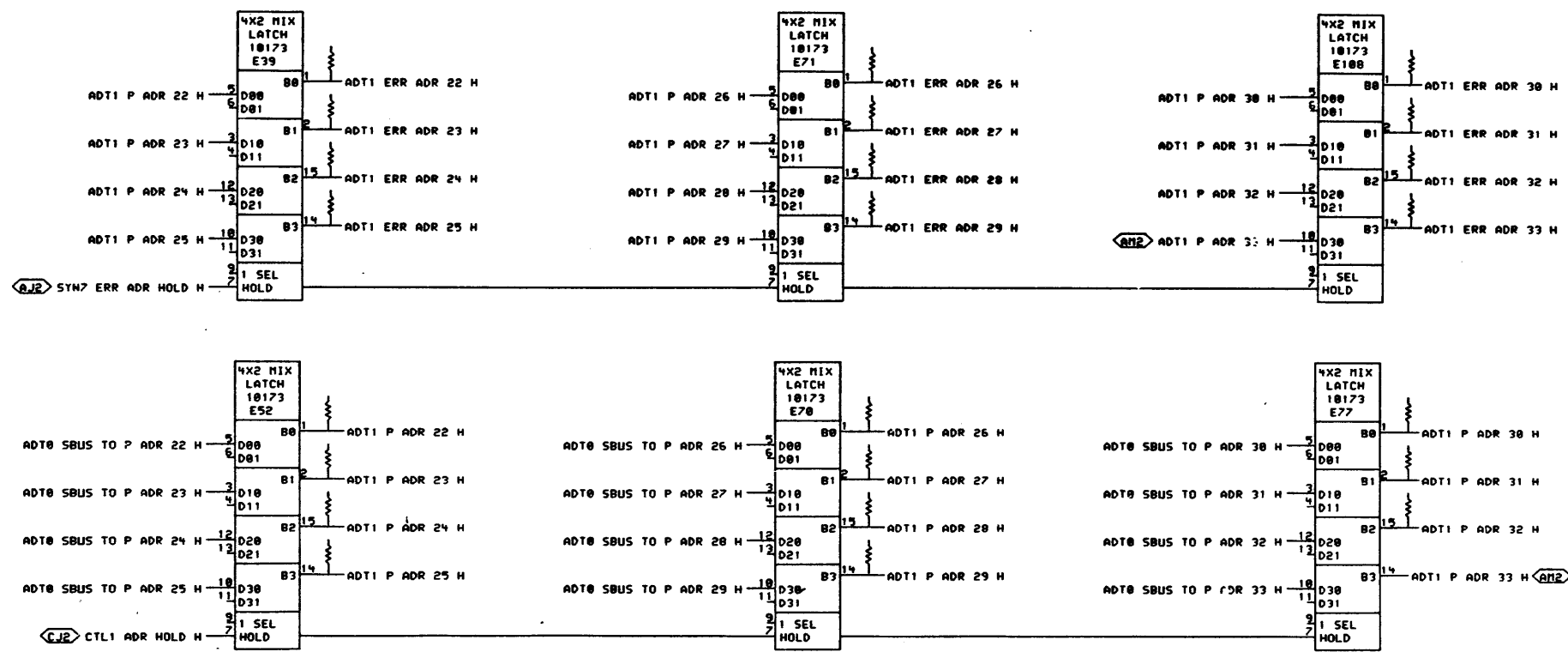

REV.  
 NUMBER  
 1104-B-22584-ADT1  
 CS  
 D  
 B

THIS DRAWING AND SPECIFICATIONS, HEREIN, ARE THE PROPERTY OF DIGITAL EQUIPMENT CORPORATION AND SHALL NOT BE REPRODUCED OR COPIED OR USED IN WHOLE OR IN PART AS THE BASIS FOR THE MANUFACTURE OR SALE OF ITEMS WITHOUT WRITTEN PERMISSION.  
 COPYRIGHT © 1978, DIGITAL EQUIPMENT CORPORATION

REVISIONS	
CHK	CHANGE NO. REV.

digital	DRN <i>Lucien</i>	DATE 27-MAR-78	ENG. <i>N. Chen</i>	DATE <i>27-Mar-78</i>	TITLE: ADDRESS AND TIME PORT ADR REG
	CHK'D <i>Y. Lucien</i>	DATE 22-JUN-78	BOARD LOCATION: 3AF07	SHEET 1 OF 1	
ADT1B.DRW 4,6671		85-MAY-78 07:00	NEXT HIGHER ASSEMBLY:	SIZE CODE D CS	NUMBER M8577-0-ADT1
FIRST USED ON OPTION/MODEL: MF20		D-DD-M8577-0		REV.	

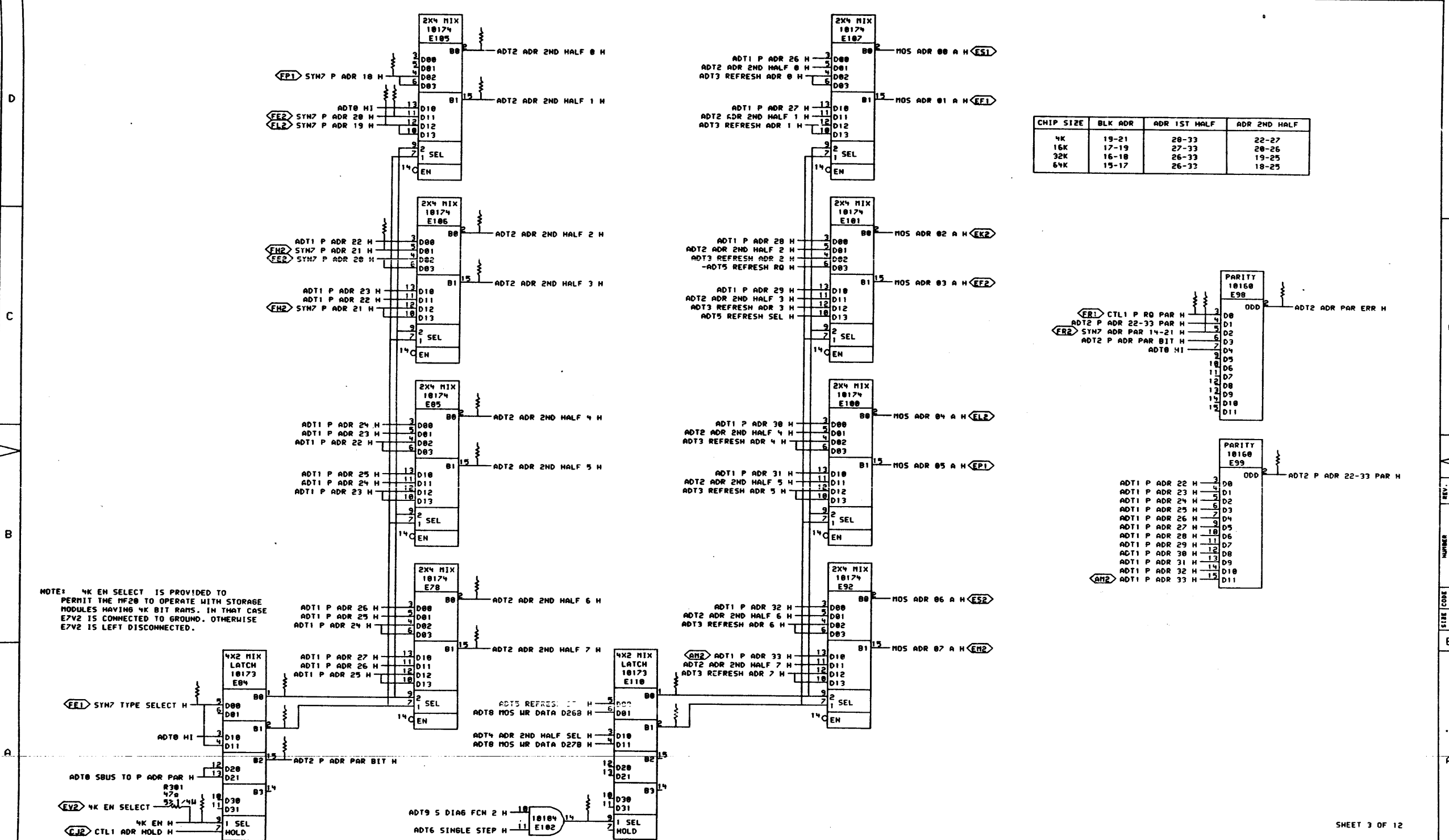

THIS DRAWING AND SPECIFICATIONS HERENTIN ARE THE PROPERTY OF DIGITAL EQUIPMENT CORPORATION AND SHALL NOT BE REPRODUCED OR COPIED OR USED IN WHOLE OR IN PART AS THE BASIS FOR THE MANUFACTURE OR SALE OF ITEMS WITHOUT WRITTEN PERMISSION. COPYRIGHT © 1978, DIGITAL EQUIPMENT CORPORATION.

REVISIONS		
CHK	CHANGE NO.	REV

**digital** DRN *DeLuca* DATE 15-MAY-78 ENG. *J. Chen* DATE *24 May 78* TITLE: ADDRESS AND TIME PORT ADR MIXERS

CHK'D *DeLuca* DATE BOARD LOCATION: 3AF87

ADT2B\_ORN(4,667) 11-MAY-78 10:16 NEXT HIGHER ASSEMBLY: SIZE CODE NUMBER REV.

FIRST USED ON OPTION/MODEL: MF20 D-DD-M8577-0 D CS M8577-0-ADT2

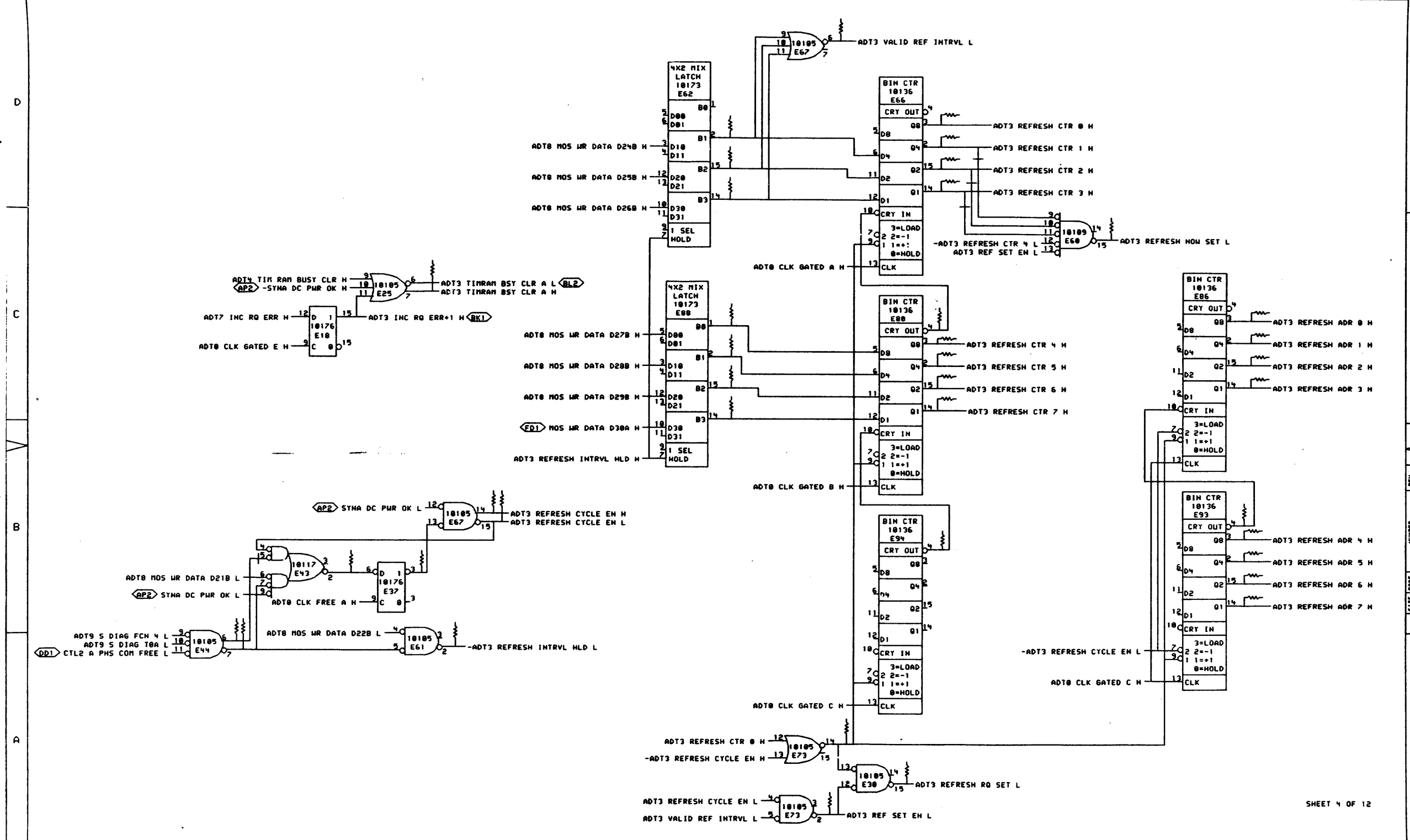

SHEET 4 OF 12

"THIS DRAWING AND SPECIFICATIONS, HEREIN, ARE THE PROPERTY OF DIGITAL EQUIPMENT CORPORATION AND SHALL NOT BE REPRODUCED OR COPIED OR USED IN WHOLE OR IN PART AS THE BASIS FOR THE MANUFACTURE OR SALE OF ITEMS WITHOUT WRITTEN PERMISSION. COPYRIGHT © 1978, DIGITAL EQUIPMENT CORPORATION"

REVISIONS	
CHG	NO. REV

DRN: <i>P. Luciani</i>	DATE: 27-MAR-78	ENG: <i>D. Chen</i>	DATE: 25-JUN-78	TITLE: ADDRESS AND TIME REFRESH CYCLE
CHK'D: <i>Luciani</i>	DATE: 25-JUN-78	BOARD LOCATION: 5A07	OF: 1	SIZE: D CS
ADT3B.DRW(4,667)	05-MAY-78 07:38	NEXT HIGHER ASSEMBLY:		NUMBER: M8577-0-ADT3
FIRST USED ON OPTION/MODEL: MF20	D-DD-M8577-0			REV: MR

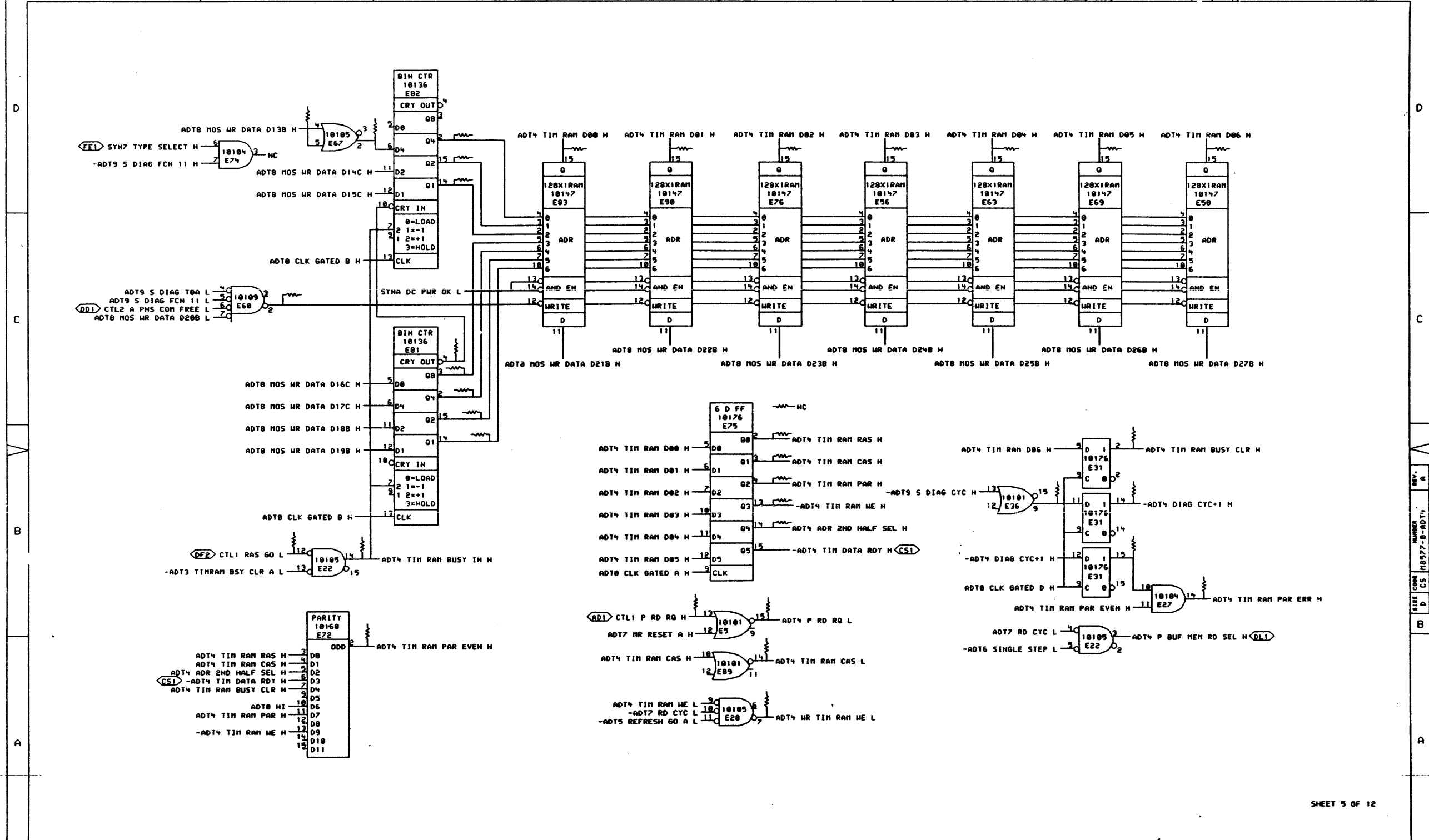

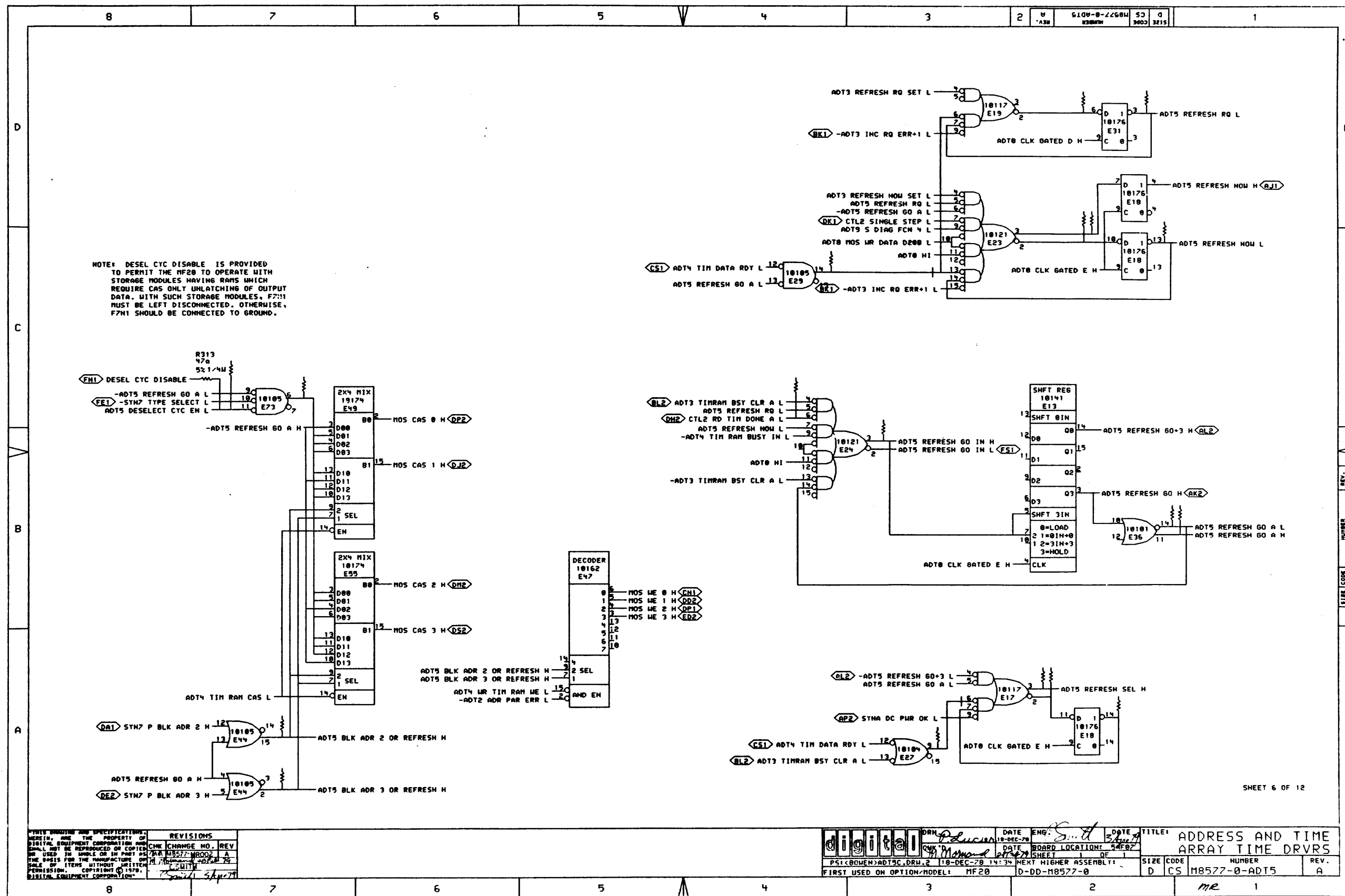

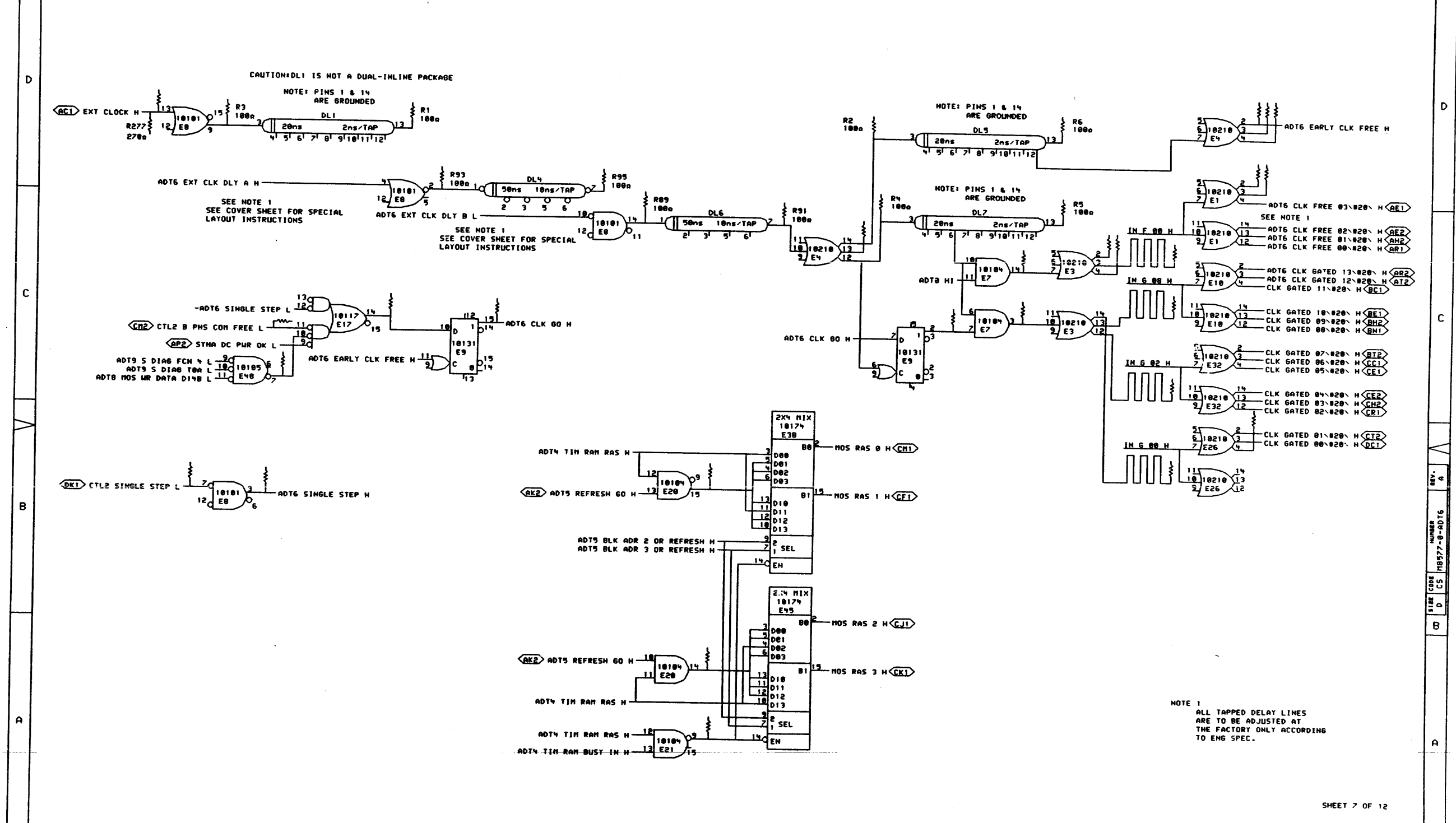

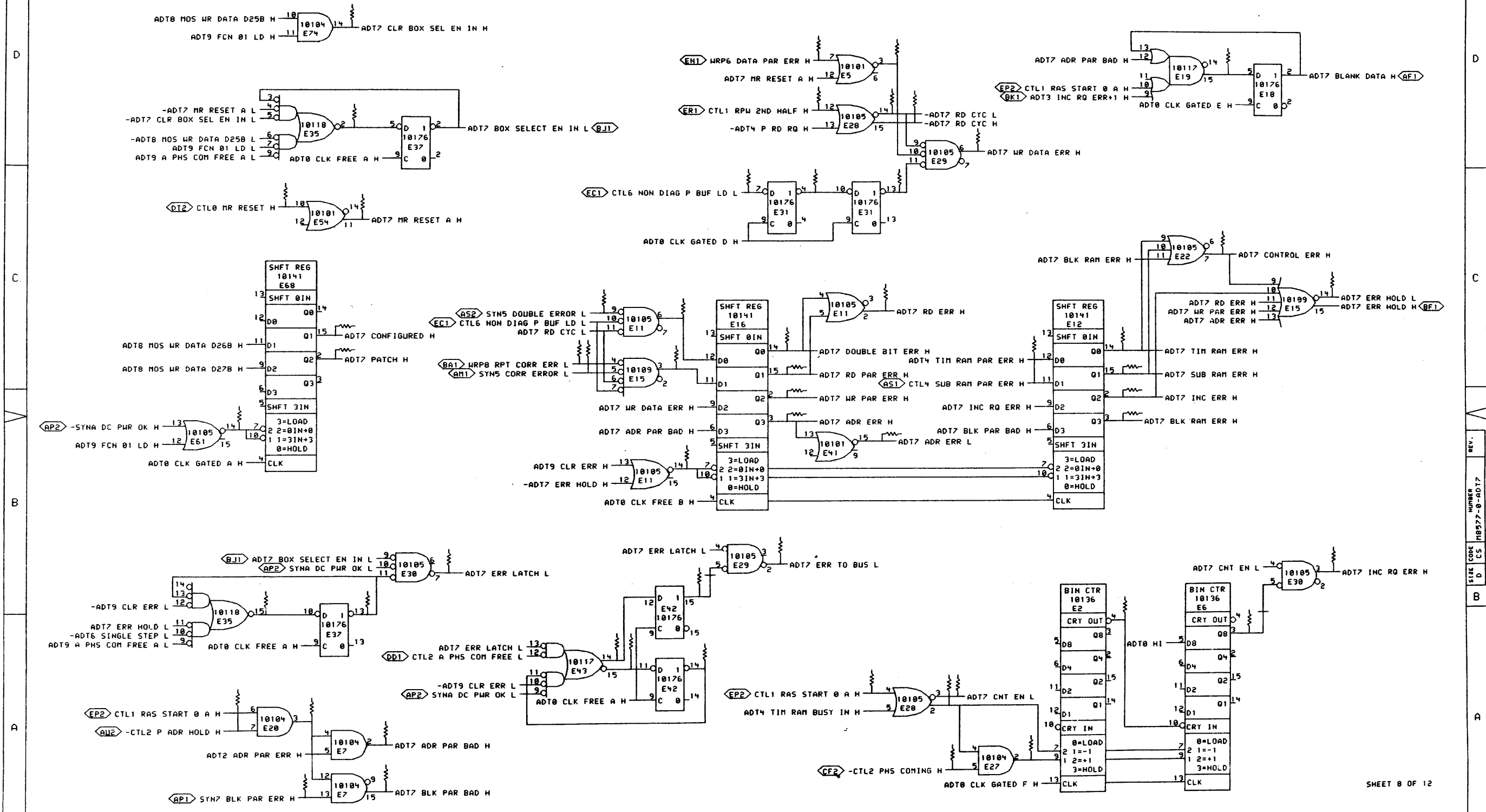

REV. 1  
 NUMBER 1  
 SIZE CODE CS  
 D CS M8577-0-ADT7  
 B  
 A

THIS DRAWING AND SPECIFICATIONS, HEREIN, ARE THE PROPERTY OF DIGITAL EQUIPMENT CORPORATION AND SHALL NOT BE REPRODUCED OR COPIED OR USED IN WHOLE OR IN PART AS THE BASIS FOR THE MANUFACTURE OR SALE OF ITEMS WITHOUT WRITTEN PERMISSION.  
 COPYRIGHT © 1978, DIGITAL EQUIPMENT CORPORATION

REVISIONS		
CHK	CHANGE NO.	REV

	DRN <i>Aducian</i>	DATE 27-MAR-78	ENG. <i>J. Kim</i>	DATE 03-MAR-78	TITLE: ADDRESS AND TIME ERR HANDLE LOGIC
	CHK <i>...</i>	DATE 23-MAY-78 07:58	BOARD LOCATION: 2AF07	SHEET 1	
ADT7B.DRM 4,6673		NEXT HIGHER ASSEMBLY:		SIZE CODE D CS	NUMBER M8577-0-ADT7
FIRST USED ON OPTION MODEL: MF20		D-DD-M8577-0		REV. 1	

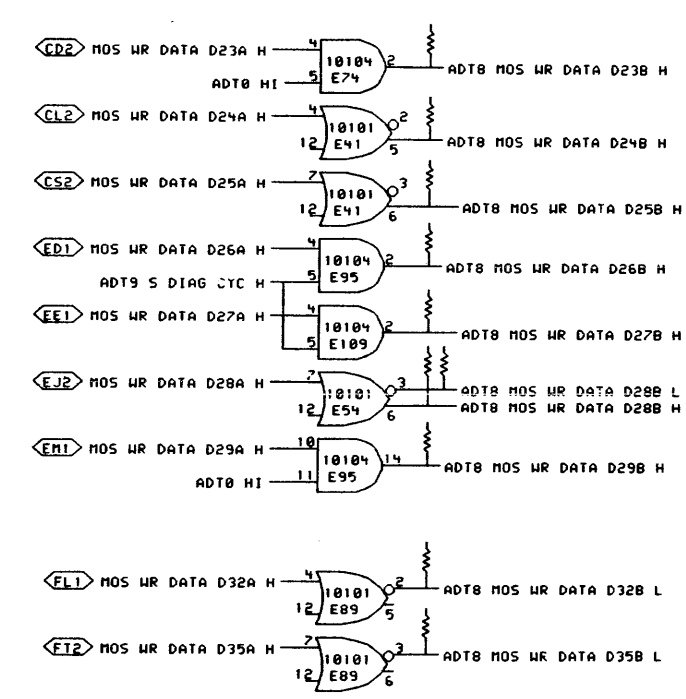
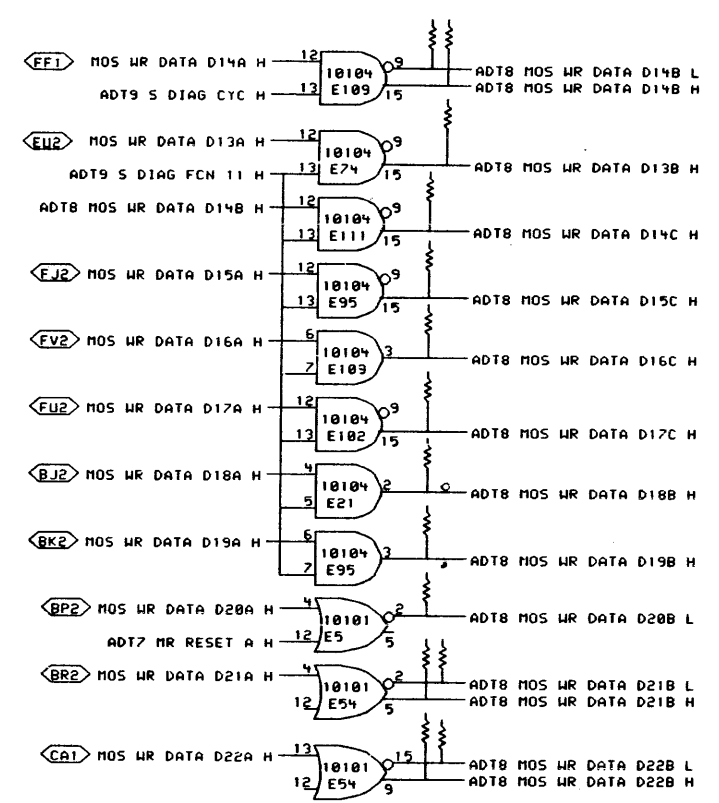

THIS DRAWING AND SPECIFICATIONS, HEREIN, ARE THE PROPERTY OF DIGITAL EQUIPMENT CORPORATION AND SHALL NOT BE REPRODUCED OR COPIED OR USED IN WHOLE OR IN PART AS THE BASIS FOR THE MANUFACTURE OR SALE OF ITEMS WITHOUT WRITTEN PERMISSION. COPYRIGHT © 1978, DIGITAL EQUIPMENT CORPORATION.

REVISIONS		
CHK	CHANGE NO.	REV.

	DRN <i>P. Lucier</i>	DATE 19-20-78	ENG. <i>D. Chen</i>	DATE 21-20-78	TITLE: ADDRESS AND TIME DATA BUFFER
	CHK <i>9.0</i>	DATE 11-24-78	BOARD LOCATION: 9A87	SHEET 1 OF 1	
PUB: M8577-MOS-ADT8B.DRW 19-JUN-78 10:12 FIRST USED ON OPTION/MODEL: MF20			NEXT HIGHER ASSEMBLY: D-DD-M8577-0		SIZE CODE D CS NUMBER M8577-0-ADT8 REV.

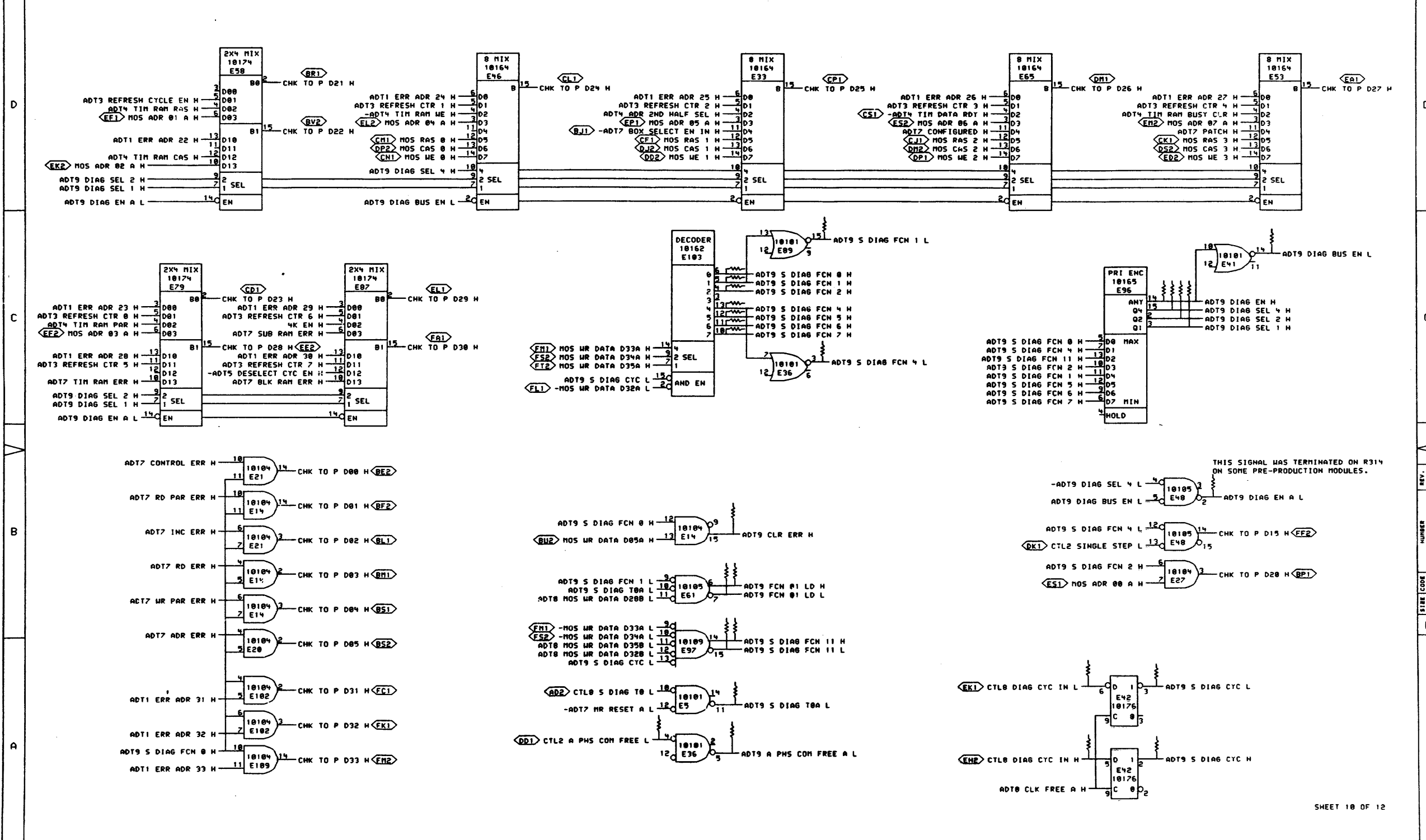

THIS DRAWING AND SPECIFICATIONS HEREIN ARE THE PROPERTY OF DIGITAL EQUIPMENT CORPORATION AND SHALL NOT BE REPRODUCED OR COPIED OR USED IN WHOLE OR IN PART AS THE BASIS FOR THE MANUFACTURE OR SALE OF ITEMS WITHOUT WRITTEN PERMISSION. COPYRIGHT © 1979, DIGITAL EQUIPMENT CORPORATION.

REVISIONS	
CHK	CHANGE NO. REV.
7/1	M8577-0-ADT9 A

<b>digital</b>	DATE: 02-20-79	ENG: <i>Smith</i>	DATE: 02-20-79	TITLE: ADDRESS AND TIME DIAGNOSTIC LOGIC
PUB: M8577-NOS)ADT9E.DRW)02-JAN-79 16:49		NEXT HIGHER ASSEMBLY: D-DD-M8577-0		SIZE CODE: D CS M8577-0-ADT9
FIRST USED ON OPTION/MODEL: MF20		BOARD LOCATION: 5E07		NUMBER: 1
		SHEET: 1		REV: A

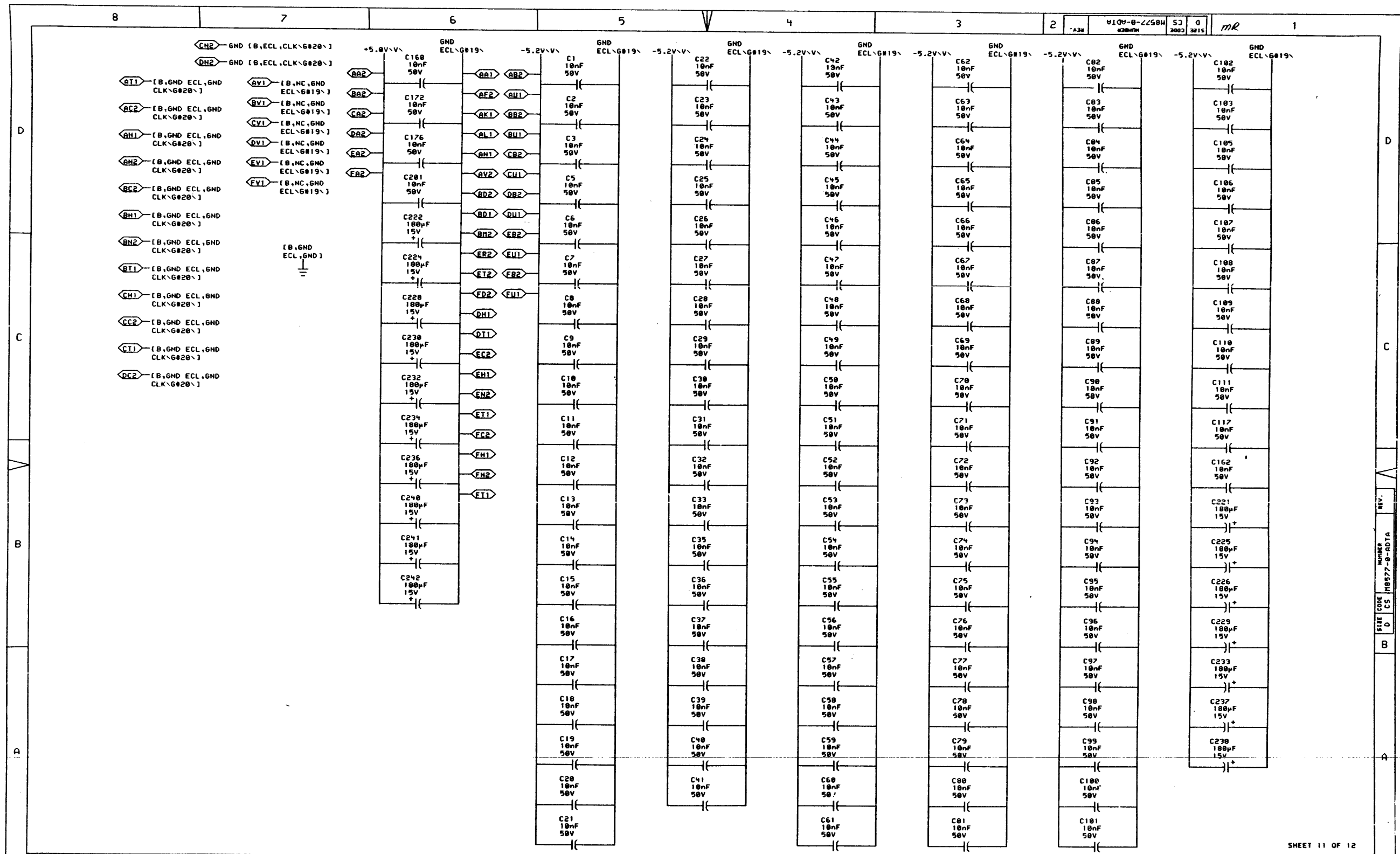

REVISIONS		
CHK	CHANGE NO.	REV.

THIS DRAWING AND SPECIFICATIONS ARE THE PROPERTY OF DIGITAL EQUIPMENT CORPORATION AND SHALL NOT BE REPRODUCED OR COPIED OR USED IN WHOLE OR IN PART AS THE BASIS FOR THE MANUFACTURE OR SALE OF ITEMS WITHOUT WRITTEN PERMISSION. COPYRIGHT © 1978, DIGITAL EQUIPMENT CORPORATION.

digital ORN *Plucian* DATE 01-JUN-78 ENG. *J. Chen* DATE 28-JUN-78  
CHK *P. S.* BOARD LOCATION: 5A8Z7  
ADTAS.DRM 4.6671 01-JUN-78 09:24 NEXT HIGHER ASSEMBLY: D-DD-M8577-0  
FIRST USED ON OPTION/MODEL: MF20

TITLE: ADDRESS AND TIME POWER, GND, CAPS.  
SIZE CODE NUMBER REV.  
D CS M8577-0-ADTA

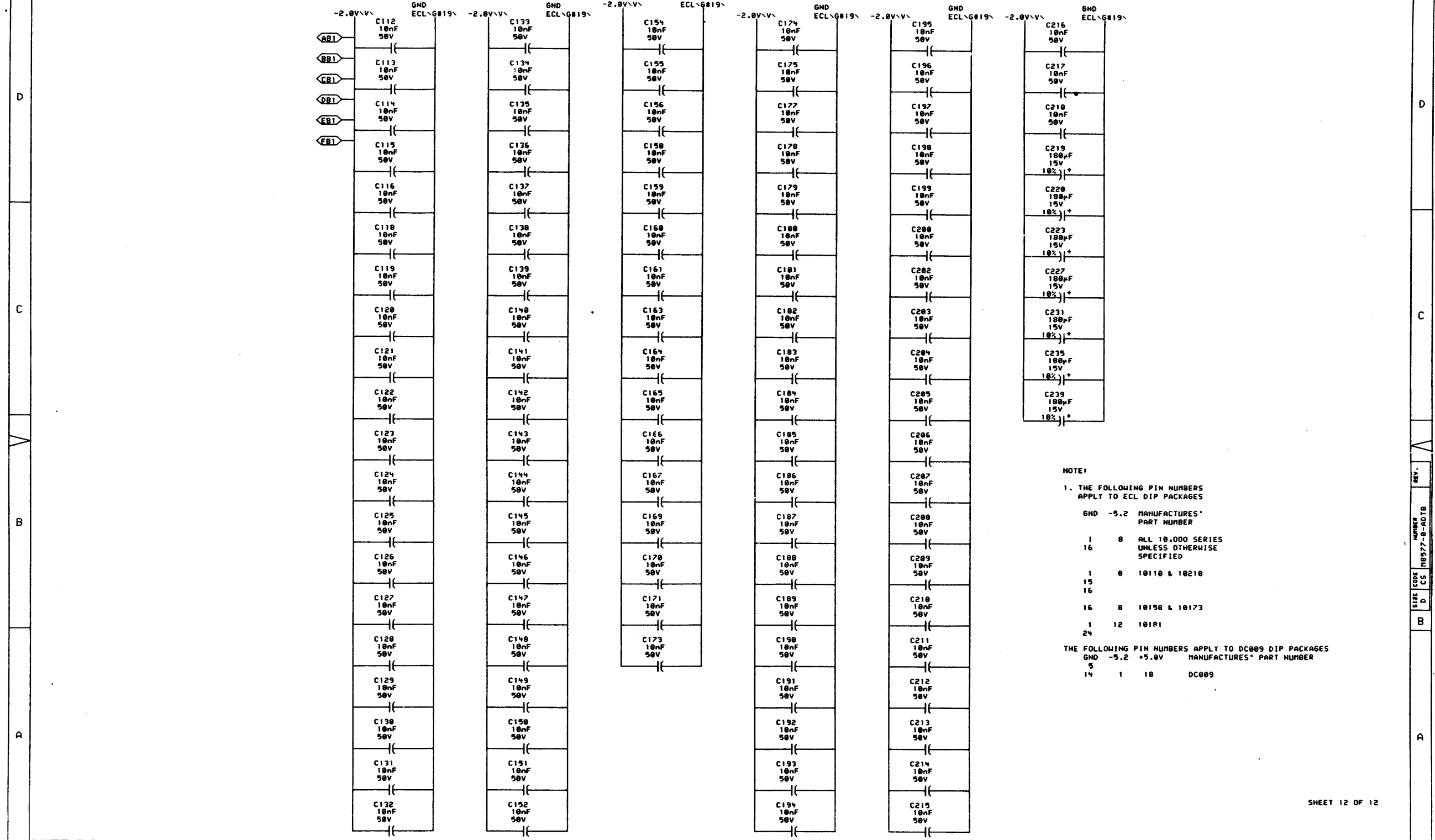

NOTE:  
 1. THE FOLLOWING PIN NUMBERS APPLY TO ECL DIP PACKAGES

SIZE	CODE	CS	NUMBER	REV.
16	8		ALL 18,000 SERIES UNLESS OTHERWISE SPECIFIED	
15	8		10110 & 10210	
16	8		10150 & 10173	
1	12		10181	
24				

THE FOLLOWING PIN NUMBERS APPLY TO DC009 DIP PACKAGES

SIZE	CODE	NUMBER	REV.
5			
14	1	18	DC009

SHEET 12 OF 12

THIS DRAWING AND SPECIFICATIONS ARE THE PROPERTY OF DIGITAL EQUIPMENT CORPORATION AND SHALL NOT BE REPRODUCED OR COPIED OR USED IN WHOLE OR IN PART AS THE BASIS FOR THE MANUFACTURE OR SALE OF ITEMS WITHOUT WRITTEN PERMISSION. COPYRIGHT © 1978, DIGITAL EQUIPMENT CORPORATION

REVISIONS		
CHK	CHANGE NO.	REV.

digital	DRN	DATE	ENG.	DATE	TITLE:
	CHK	DATE	NAME	DATE	ADDRESS AND TIME POWER. GND. CAPS.
ADTB-DRAW 4,667		01-JUN-78 09:59	101	01-JUN-78	1 OF 1
FIRST USED ON OPTION/MODEL: HF20		NEXT HIGHER ASSEMBLY: D-DD-M8577-0		SIZE CODE	NUMBER
				D CS	M8577-0-ADTB

RESISTOR LOC(PIN)	SHOWN ON DRUM	REF	VALUE	TERMINATES SIGNAL	RESISTOR LOC(PIN)	SHOWN ON DRUM	REF	VALUE	TERMINATES SIGNAL	RESISTOR LOC(PIN)	SHOWN ON DRUM	REF	VALUE	TERMINATES SIGNAL	RESISTOR LOC(PIN)	SHOWN ON DRUM	REF	VALUE	TERMINATES SIGNAL
R1<1>	ADT6	D6	100Ω	%DL1<13>	R21<1>	ADT7	D7	60Ω	%E35<2>	R36<1>	ADT4	D6	60Ω	%E02<15>	R220<1>	ADT1	C4	60Ω	ADT1 ERR ADR 20 H
R95<1>	ADT6	D5	100Ω	%DL4<7>	R12<1>	ADT4	B3	60Ω	%E36<9>	R37<1>	ADT4	D6	60Ω	%E02<2>	R105<1>	ADT1	C4	60Ω	ADT1 ERR ADR 29 H
R6<1>	ADT6	D3	100Ω	%DL5<13>	R102<1>	ADT7	B7	60Ω	%E37<13>	R311<1>	ADT2	A7	60Ω	%E04<1>	R100<1>	ADT1	C2	60Ω	ADT1 ERR ADR 30 H
R91<1>	ADT6	C4	100Ω	%DL6<7>	R121<1>	ADT3	B6	60Ω	%E37<3>	R312<1>	ADT2	A7	60Ω	%E04<2>	R130<1>	ADT1	C2	60Ω	ADT1 ERR ADR 31 H
R5<1>	ADT6	C3	100Ω	%DL7<13>	R4<1>	ADT6	C4	100Ω	%E4<12>	R179<1>	ADT3	C4	60Ω	%E00<1>	R139<1>	ADT1	C2	60Ω	ADT1 ERR ADR 32 H
R201<1>	ADT6	D2	60Ω	%E1<2>	R42<1>	ADT6	C4	60Ω	%E4<13>	R172<1>	ADT3	C4	60Ω	%E00<14>	R140<1>	ADT1	C2	60Ω	ADT1 ERR ADR 33 H
R276<1>	ADT6	D1	60Ω	%E1<3>	R2<1>	ADT6	D4	100Ω	%E4<14>	R173<1>	ADT3	C4	60Ω	%E00<15>	R275<1>	ADT1	B6	60Ω	ADT1 P ADR 22 H
R00<1>	ADT2	A5	60Ω	%E102<14>	R43<1>	ADT6	D1	60Ω	%E4<3>	R101<1>	ADT3	C4	60Ω	%E00<2>	R270<1>	ADT1	B6	60Ω	ADT1 P ADR 23 H
R156<1>	ADT7	B5	60Ω	%E11<14>	R49<1>	ADT6	D1	60Ω	%E4<4>	R147<1>	ADT6	C3	60Ω	%E9<2>	R274<1>	ADT1	B6	60Ω	ADT1 P ADR 24 H
R151<1>	ADT7	C5	60Ω	%E11<6>	R61<1>	ADT7	A5	60Ω	%E42<14>	R235<1>	ADT3	B1	60Ω	%E93<4>	R273<1>	ADT1	B6	60Ω	ADT1 P ADR 25 H
R264<1>	ADT2	A5	60Ω	%E110<1>	R104<1>	ADT7	B5	60Ω	%E42<15>	R177<1>	ADT3	B3	60Ω	%E94<4>	R241<1>	ADT1	B4	60Ω	ADT1 P ADR 26 H
R267<1>	ADT2	A5	60Ω	%E110<2>	R100<1>	ADT7	A5	60Ω	%E43<14>	R104<1>	ADT2	A7	50Ω	HK EM H	R243<1>	ADT1	B4	60Ω	ADT1 P ADR 27 H
R154<1>	ADT7	C5	60Ω	%E15<3>	R112<1>	ADT7	A5	60Ω	%E43<15>	R19<1>	ADT0	D5	60Ω	ADT0 CLK FREE A H	R195<1>	ADT1	B4	60Ω	ADT1 P ADR 28 H
R44<1>	ADT6	C6	60Ω	%E17<14>	R15<1>	ADT3	B7	60Ω	%E43<2>	R152<1>	ADT0	D5	60Ω	ADT0 CLK FREE B H	R109<1>	ADT1	B4	60Ω	ADT1 P ADR 29 H
R54<1>	ADT5	A2	60Ω	%E17<2>	R65<1>	ADT3	A7	60Ω	%E44<6>	R226<1>	ADT0	D5	60Ω	ADT0 CLK FREE C H	R190<1>	ADT1	B2	60Ω	ADT1 P ADR 30 H
R90<1>	ADT5	A2	60Ω	%E10<14>	R120<1>	ADT3	A7	60Ω	%E44<7>	R74<1>	ADT0	C5	60Ω	ADT0 CLK GATED A H	R194<1>	ADT1	B2	60Ω	ADT1 P ADR 31 H
R52<1>	ADT7	D2	60Ω	%E19<15>	R92<1>	ADT6	C7	60Ω	%E40<7>	R77<1>	ADT0	C5	60Ω	ADT0 CLK GATED B H	R197<1>	ADT1	B2	60Ω	ADT1 P ADR 32 H
R16<1>	ADT5	D2	60Ω	%E19<2>	R106<1>	ADT7	D4	60Ω	%E5<3>	R100<1>	ADT0	C5	60Ω	ADT0 CLK GATED C H	R242<1>	ADT2	D6	60Ω	ADT2 ADR 2ND HALF 0 H
R202<1>	ADT7	A2	60Ω	%E2<4>	R56<1>	ADT7	A2	60Ω	%E6<3>	R13<1>	ADT0	D5	60Ω	ADT0 CLK GATED D H	R244<1>	ADT2	D6	60Ω	ADT2 ADR 2ND HALF 1 H
R290<1>	ADT6	A5	60Ω	%E20<14>	R29<1>	ADT4	C7	60Ω	%E60<2>	R47<1>	ADT0	D5	60Ω	ADT0 CLK GATED E H	R193<1>	ADT2	C6	60Ω	ADT2 ADR 2ND HALF 2 H
R209<1>	ADT6	B5	60Ω	%E20<15>	R73<1>	ADT7	B7	60Ω	%E61<14>	R200<1>	ADT0	D5	60Ω	ADT0 CLK GATED F H	R191<1>	ADT2	C6	60Ω	ADT2 ADR 2ND HALF 3 H
R140<1>	ADT7	A7	60Ω	%E20<3>	R167<1>	ADT3	D4	60Ω	%E62<14>	R237<1>	ADT0	B5	60Ω	ADT0 SBUS TO P ADR 22 H	R236<1>	ADT2	C6	60Ω	ADT2 ADR 2ND HALF 4 H
R317<1>	ADT6	A5	60Ω	%E21<9>	R160<1>	ADT3	D4	60Ω	%E62<15>	R256<1>	ADT0	B5	60Ω	ADT0 SBUS TO P ADR 23 H	R239<1>	ADT2	B6	60Ω	ADT2 ADR 2ND HALF 5 H
R53<1>	ADT5	C2	60Ω	%E23<2>	R169<1>	ADT3	D4	60Ω	%E62<2>	R251<1>	ADT0	B5	60Ω	ADT0 SBUS TO P ADR 24 H	R263<1>	ADT2	B6	60Ω	ADT2 ADR 2ND HALF 6 H
R51<1>	ADT5	C2	60Ω	%E23<3>	R76<1>	ADT4	D6	60Ω	%E67<2>	R254<1>	ADT0	D3	60Ω	ADT0 SBUS TO P ADR 25 H	R266<1>	ADT2	B6	60Ω	ADT2 ADR 2ND HALF 7 H
R206<1>	ADT6	B2	60Ω	%E26<4>	R122<1>	ADT4	D7	60Ω	%E67<5>	R296<1>	ADT0	D3	60Ω	ADT0 SBUS TO P ADR 26 H	R145<1>	ADT2	C1	60Ω	ADT2 ADR PAR ERR H
R199<1>	ADT7	A3	60Ω	%E27<2>	R143<1>	ADT6	C3	60Ω	%E7<14>	R295<1>	ADT0	C3	60Ω	ADT0 SBUS TO P ADR 27 H	R305<1>	ADT2	B1	60Ω	ADT2 P ADR 22-33 PAR H
R99<1>	ADT5	A3	60Ω	%E27<9>	R144<1>	ADT6	C3	60Ω	%E7<3>	R292<1>	ADT0	C3	60Ω	ADT0 SBUS TO P ADR 28 H	R300<1>	ADT2	A7	60Ω	ADT2 P ADR PAR BIT H
R201<1>	ADT7	A3	60Ω	%E20<2>	R176<1>	ADT3	A4	60Ω	%E73<14>	R293<1>	ADT0	C3	60Ω	ADT0 SBUS TO P ADR 29 H	R50<1>	ADT3	A4	60Ω	-ADT3 REF SET EM H
R7<1>	ADT5	C4	60Ω	%E29<14>	R67<1>	ADT5	C7	60Ω	%E73<6>	R299<1>	ADT0	C3	60Ω	ADT0 SBUS TO P ADR 30 H	R245<1>	ADT3	C1	60Ω	ADT3 REFRESH ADR 0 H
R250<1>	ADT6	C2	60Ω	%E3<12>	R09<1>	ADT6	C5	100Ω	%E8<14>	R300<1>	ADT0	B3	60Ω	ADT0 SBUS TO P ADR 31 H	R246<1>	ADT3	C1	60Ω	ADT3 REFRESH ADR 1 H
R240<1>	ADT6	B2	60Ω	%E3<14>	R93<1>	ADT6	D6	100Ω	%E0<2>	R294<1>	ADT0	B3	60Ω	ADT0 SBUS TO P ADR 32 H	R196<1>	ADT3	C1	60Ω	ADT3 REFRESH ADR 2 H
R142<1>	ADT6	C2	60Ω	%E3<2>	R3<1>	ADT6	D7	100Ω	%E0<9>	R297<1>	ADT0	B3	60Ω	ADT0 SBUS TO P ADR 33 H	R190<1>	ADT3	C1	60Ω	ADT3 REFRESH ADR 3 H
R247<1>	ADT6	C2	60Ω	%E3<3>	R164<1>	ADT3	C3	60Ω	%E00<4>	R290<1>	ADT0	A3	60Ω	ADT0 SBUS TO P ADR PAR H	R237<1>	ADT3	B1	60Ω	ADT3 REFRESH ADR 4 H
R141<1>	ADT6	C2	60Ω	%E3<4>	R31<1>	ADT4	B6	60Ω	%E01<14>	R295<1>	ADT1	C6	60Ω	ADT1 ERR ADR 22 H	R240<1>	ADT3	B1	60Ω	ADT3 REFRESH ADR 5 H
R105<1>	ADT7	C4	60Ω	%E31<13>	R33<1>	ADT4	C6	60Ω	%E01<15>	R233<1>	ADT1	C6	60Ω	ADT1 ERR ADR 23 H	R260<1>	ADT3	B1	60Ω	ADT3 REFRESH ADR 6 H
R217<1>	ADT4	B2	60Ω	%E31<15>	R30<1>	ADT4	C6	60Ω	%E01<2>	R253<1>	ADT1	C6	60Ω	ADT1 ERR ADR 24 H	R265<1>	ADT3	B1	60Ω	ADT3 REFRESH ADR 7 H
R14<1>	ADT7	C4	60Ω	%E31<4>	R20<1>	ADT4	C6	60Ω	%E01<3>	R210<1>	ADT1	C6	60Ω	ADT1 ERR ADR 25 H	R234<1>	ADT3	D3	60Ω	ADT3 REFRESH CTR 0 H
R20<1>	ADT7	B7	60Ω	%E35<15>	R00<1>	ADT4	C6	60Ω	%E01<4>	R262<1>	ADT1	C4	60Ω	ADT1 ERR ADR 26 H	R252<1>	ADT3	D3	60Ω	ADT3 REFRESH CTR 1 H
					R35<1>	ADT4	D6	60Ω	%E02<14>	R224<1>	ADT1	C4	60Ω	ADT1 ERR ADR 27 H	R219<1>	ADT3	D3	60Ω	ADT3 REFRESH CTR 2 H

NOTE:  
 1. ALL TERMINATORS HAVE PIN TWO CONNECTED TO -2.0V AND ARE 5% 1/4WATT UNLESS OTHERWISE SPECIFIED  
 2. ENTRIES ARE SORTED BY SIGNAL NAME  
 3. % INDICATES OUTPUT OF DIP LOC AND (<) INDICATES PIN NUMBER

THIS DRAWING AND SPECIFICATIONS HEREIN ARE THE PROPERTY OF DIGITAL EQUIPMENT CORPORATION AND SHALL NOT BE REPRODUCED OR COPIED OR USED IN WHOLE OR IN PART AS THE BASIS FOR THE MANUFACTURE OR SALE OF ITEMS WITHOUT WRITTEN PERMISSION. COPYRIGHT © 1979, DIGITAL EQUIPMENT CORPORATION.		<b>REVISIONS</b> CHK CHANGE NO. REV 10/15/79 10/15/79 10/15/79 10/15/79 10/15/79 10/15/79		DATE ENG'D: 10/15/79 DATE: 10/15/79 DRAWN BY: [Signature] CHECKED BY: [Signature]	TITLE: RESISTOR DRAWING ADDRESS AND TIME BOARD LOCATION: 28/28 SHEET: 1 OF 2	SIZE CODE: D CS NUMBER: M8577-0-RES REV.: A
---	--	---	--	--	--	---

8			7			6			5			4			3			2			1			
RESISTOR LOC(PIN)	SHOWN ON DRW#	VALUE	TERMINATES SIGNAL	RESISTOR LOC(PIN)	SHOWN ON DRW#	VALUE	TERMINATES SIGNAL	RESISTOR LOC(PIN)	SHOWN ON DRW#	VALUE	TERMINATES SIGNAL	RESISTOR LOC(PIN)	SHOWN ON DRW#	VALUE	TERMINATES SIGNAL	RESISTOR LOC(PIN)	SHOWN ON DRW#	VALUE	TERMINATES SIGNAL	RESISTOR LOC(PIN)	SHOWN ON DRW#	VALUE	TERMINATES SIGNAL	
R263(1)	ADT3	D3	68a	ADT3	D3	68a	ADT3 REFRESH CTR 3 H	R86(1)	ADT5	A2	68a	ADT5 REFRESH SEL H	R166(1)	ADT8	B6	68a	-ADT8 NOS HR DATA D200 H	R278(1)	ADT4	B5	68a	CTL1 P RD RQ H		
R223(1)	ADT3	C3	68a	ADT3	C3	68a	ADT3 REFRESH CTR 4 H	R227(1)	ADT8	D6	68a	ADT6 CLK FREE [B,IN,03]~020\ H	R27(1)	ADT8	B6	68a	ADT8 NOS HR DATA D218 H	R386(1)	ADT2	C2	68a	CTL1 P RQ PAR H		
R238(1)	ADT3	C3	68a	ADT3	C3	68a	ADT3 REFRESH CTR 5 H	R228(1)	ADT8	C6	68a	ADT6 CLK GATED [B,IN,13]~020\ H	R66(1)	ADT8	B6	68a	-ADT8 NOS HR DATA D218 H	R213(1)	ADT4	B7	68a	-CTL1 RAS GO H		
R187(1)	ADT3	C3	68a	ADT3	C3	68a	ADT3 REFRESH CTR 6 H	R40(1)	ADT6	C6	68a	ADT6 CLK 60 H	R32(1)	ADT8	B6	68a	ADT8 NOS HR DATA D228 H	R9(1)	ADT7	A4	68a	CTL1 RAS START 0 A H		
R183(1)	ADT3	C3	68a	ADT3	C3	68a	ADT3 REFRESH CTR 7 H	R45(1)	ADT6	D2	68a	ADT6 EARLY CLK FREE H	R117(1)	ADT8	B6	68a	-ADT8 NOS HR DATA D228 H	R157(1)	ADT7	C4	68a	CTL1 RPH 2ND HALF H		
R238(1)	ADT3	B6	68a	ADT3	B6	68a	ADT3 REFRESH CYCLE EN H	R134(1)	ADT6	B7	68a	ADT6 SINGLE STEP H	R26(1)	ADT8	C3	68a	ADT8 NOS HR DATA D238 H	R23(1)	ADT9	A5	68a	-CTL2 A PHS COM FREE H		
R68(1)	ADT3	B6	68a	-ADT3	B6	68a	REFRESH CYCLE EN H	R384(1)	ADT7	B4	68a	ADT7 ADR ERR H	R69(1)	ADT8	C3	68a	ADT8 NOS HR DATA D248 H	R58(1)	ADT6	C7	68a	-CTL2 B PHS COM FREE H		
R135(1)	ADT3	A6	68a	ADT3	A6	68a	REFRESH INTRVL HLD H	R383(1)	ADT7	B4	68a	-ADT7 ADR ERR H	R124(1)	ADT8	C3	68a	ADT8 NOS HR DATA D258 H	R288(1)	ADT7	A7	68a	-CTL2 P ADR HOLD H		
R188(1)	ADT3	C2	68a	ADT3	C2	68a	REFRESH NOW SET H	R18(1)	ADT7	A6	68a	ADT7 ADR PAR BAD H	R25(1)	ADT8	B3	68a	ADT8 NOS HR DATA D268 H	R215(1)	ADT7	A3	68a	-CTL2 PHS COMING H		
R8(1)	ADT3	A3	68a	ADT3	A3	68a	REFRESH RO SET H	R149(1)	ADT7	A6	68a	ADT7 BLK PAR BAD H	R24(1)	ADT8	B3	68a	ADT8 NOS HR DATA D278 H	R55(1)	ADT5	C4	68a	-CTL2 RD TIM DONE A H		
R155(1)	ADT3	C6	68a	ADT3	C6	68a	TIMRAM BSY CLR A H	R182(1)	ADT7	B2	68a	ADT7 BLK RAM ERR H	R136(1)	ADT8	B3	68a	ADT8 NOS HR DATA D288 H	R94(1)	ADT6	B8	68a	-CTL2 SINGLE STEP H		
R175(1)	ADT3	D4	68a	ADT3	D4	68a	VALID REF INTRVL H	R189(1)	ADT7	D7	68a	ADT7 CLR BOX SEL EN IN H	R118(1)	ADT8	B3	68a	-ADT8 NOS HR DATA D288 H	R283(1)	ADT7	C3	68a	CTL4 SUB RAM PAR ERR H		
R87(1)	ADT4	B4	68a	ADT4	B4	68a	ADR 2ND HALF SEL H	R57(1)	ADT7	A3	68a	-ADT7 CNT EN H	R133(1)	ADT8	B3	68a	ADT8 NOS HR DATA D298 H	R18(1)	ADT7	C4	68a	-CTL6 NON DIAG P BUF LD H		
R11(1)	ADT4	B2	68a	ADT4	B2	68a	DIAG CYC4 H	R268(1)	ADT7	C7	68a	ADT7 CONFIGURED H	R39(1)	ADT8	B3	68a	-ADT8 NOS HR DATA D328 H	R114(1)	ADT9	A2	68a	CTL8 DIAG CYC IN H		
R158(1)	ADT4	B4	68a	ADT4	B4	68a	P RD RQ H	R288(1)	ADT7	C2	68a	ADT7 CONTROL ERR H	R48(1)	ADT8	B3	68a	-ADT8 NOS HR DATA D358 H	R113(1)	ADT9	A2	68a	-CTL8 DIAG CYC IN H		
R229(1)	ADT4	B2	68a	ADT4	B2	68a	TIM RAM BUST CLR H	R287(1)	ADT7	C4	68a	ADT7 DOUBLE BIT ERR H	R111(1)	ADT9	A4	68a	ADT9 A PHS COM FREE A H	R98(1)	ADT6	D8	68a	EXT CLOCK H		
R131(1)	ADT4	B7	68a	ADT4	B7	68a	TIM RAM BUST IN H	R183(1)	ADT7	C1	68a	-ADT7 ERR HOLD H	R63(1)	ADT9	B4	68a	ADT9 CLR ERR H	R277(1)	ADT6	D8	270a	EXT CLOCK H		
R258(1)	ADT4	B4	68a	ADT4	B4	68a	TIM RAM CAS H	R59(1)	ADT7	B6	68a	-ADT7 ERR LATCH H	R163(1)	ADT9	C1	68a	-ADT9 DIAG BUS EN H	R287(1)	ADT4	C4	68a	NC		
R64(1)	ADT4	A4	68a	ADT4	A4	68a	TIM RAM CAS H	R382(1)	ADT7	B4	68a	-ADT7 ERR TO BUS H	R168(1)	ADT9	C2	68a	ADT9 DIAG EH H	R289(1)	ADT7	C5	68a	-SYN5 CORR ERROR H		
R78(1)	ADT4	D5	68a	ADT4	D5	68a	TIM RAM D00 H	R212(1)	ADT7	B2	68a	ADT7 INC ERR H	R178(1)	ADT9	B1	68a	-ADT9 DIAG EN A H	R285(1)	ADT7	C5	68a	-SYN5 DOUBLE ERROR H		
R79(1)	ADT4	D5	68a	ADT4	D5	68a	TIM RAM D01 H	R158(1)	ADT7	B1	68a	ADT7 INC RD ERR H	R261(1)	ADT9	C2	68a	ADT9 DIAG SEL 1 H	R387(1)	ADT2	C2	68a	SYN7 ADR PAR 14-21 H		
R126(1)	ADT4	D4	68a	ADT4	D4	68a	TIM RAM D02 H	R279(1)	ADT7	C7	68a	ADT7 MR RESET A H	R259(1)	ADT9	C2	68a	ADT9 DIAG SEL 2 H	R146(1)	ADT7	A7	68a	SYN7 BLK PAR ERR H		
R75(1)	ADT4	D4	68a	ADT4	D4	68a	TIM RAM D03 H	R162(1)	ADT7	C7	68a	ADT7 PATCH H	R222(1)	ADT9	C2	68a	ADT9 DIAG SEL 4 H	R389(1)	ADT2	D6	68a	SYN7 P ADR 18 H		
R72(1)	ADT4	D3	68a	ADT4	D3	68a	TIM RAM D04 H	R187(1)	ADT7	D4	68a	ADT7 RD CYC H	R125(1)	ADT9	B4	68a	ADT9 FCN 01 LD H	R318(1)	ADT2	D6	68a	SYN7 P ADR 19 H		
R71(1)	ADT4	D2	68a	ADT4	D2	68a	TIM RAM D05 H	R286(1)	ADT7	D4	68a	-ADT7 RD CYC H	R118(1)	ADT9	B5	68a	-ADT9 FCN 01 LD H	R272(1)	ADT2	D6	68a	SYN7 P ADR 20 H		
R17(1)	ADT4	D2	68a	ADT4	D2	68a	TIM RAM D06 H	R284(1)	ADT7	C4	68a	ADT7 RD ERR H	R137(1)	ADT9	A2	68a	ADT9 S DIAG CYC H	R271(1)	ADT2	C6	68a	SYN7 P ADR 21 H		
R232(1)	ADT4	B4	68a	ADT4	B4	68a	TIM RAM PAR H	R283(1)	ADT7	C4	68a	ADT7 RD PAR ERR H	R34(1)	ADT9	A2	68a	-ADT9 S DIAG CYC H	R127(1)	ADT2	A7	68a	SYN7 TYPE SELECT H		
R284(1)	ADT4	B2	68a	ADT4	B2	68a	TIM RAM PAR ERR H	R186(1)	ADT7	C2	68a	ADT7 SUB RAM ERR H	R282(1)	ADT9	C5	68a	ADT9 S DIAG FCN 0 H	R288(1)	ADT7	D4	68a	WRP6 DATA PAR ERR H		
R216(1)	ADT4	A6	68a	ADT4	A6	68a	TIM RAM PAR EVEN H	R231(1)	ADT7	C2	68a	ADT7 TIM RAM ERR H	R82(1)	ADT9	C5	68a	ADT9 S DIAG FCN 1 H	R218(1)	ADT7	C5	68a	-WRP8 RPT CORR ERR H		
R318(1)	ADT4	B4	68a	ADT4	B4	68a	TIM RAM RAS H	R153(1)	ADT7	D3	68a	ADT7 HR DATA ERR H	R119(1)	ADT9	C4	68a	-ADT9 S DIAG FCN 1 H							
R159(1)	ADT4	B4	68a	ADT4	B4	68a	TIM RAM WE H	R285(1)	ADT7	B4	68a	ADT7 HR PAR ERR H	R211(1)	ADT9	B4	68a	ADT9 S DIAG FCN 11 H							
R161(1)	ADT4	A4	68a	ADT4	A4	68a	HR TIM RAM WE H	R123(1)	ADT8	C6	68a	ADT8 NOS HR DATA D138 H	R165(1)	ADT9	B5	68a	-ADT9 S DIAG FCN 11 H							
R315(1)	ADT5	A7	68a	ADT5	A7	68a	BLK ADR 2 OR REFRESH H	R4(1)	ADT8	D6	68a	ADT8 NOS HR DATA D148 H	R214(1)	ADT9	C5	68a	ADT9 S DIAG FCN 2 H							
R316(1)	ADT5	A7	68a	ADT5	A7	68a	BLK ADR 3 OR REFRESH H	R115(1)	ADT8	D6	68a	-ADT8 NOS HR DATA D148 H	R62(1)	ADT9	C5	68a	ADT9 S DIAG FCN 4 H							
R171(1)	ADT5	C7	68a	ADT5	C7	68a	DESELECT CYC EN H	R8(1)	ADT8	C6	68a	ADT8 NOS HR DATA D148 H	R18(1)	ADT9	C4	68a	-ADT9 S DIAG FCN 4 H							
R178(1)	ADT5	B1	68a	ADT5	B1	68a	REFRESH GO A H	R78(1)	ADT8	C6	68a	ADT8 NOS HR DATA D158 H	R83(1)	ADT9	C5	68a	ADT9 S DIAG FCN 5 H							
R68(1)	ADT5	B2	68a	ADT5	B2	68a	REFRESH GO A H	R138(1)	ADT8	C6	68a	ADT8 NOS HR DATA D168 H	R84(1)	ADT9	C5	68a	ADT9 S DIAG FCN 6 H							
R46(1)	ADT5	B3	68a	ADT5	B3	68a	REFRESH GO IN H	R132(1)	ADT8	C6	68a	ADT8 NOS HR DATA D178 H	R85(1)	ADT9	C5	68a	ADT9 S DIAG FCN 7 H							
R96(1)	ADT5	C2	68a	ADT5	C2	68a	REFRESH NOW H	R129(1)	ADT8	B6	68a	ADT8 NOS HR DATA D188 H	R22(1)	ADT9	A4	68a	-ADT9 S DIAG T0A H							
R192(1)	ADT5	D2	68a	ADT5	D2	68a	REFRESH RO H	R128(1)	ADT8	B6	68a	ADT8 NOS HR DATA D198 H	R116(1)	ADT7	C7	68a	CTL8 MR RESET H							

NOTE:  
1. ALL TERMINATORS HAVE PIN TWO CONNECTED TO -2.0V AND ARE 5% 1/4WATT UNLESS OTHERWISE SPECIFIED  
2. ENTRIES ARE SORTED BY SIGNAL NAME  
3. % INDICATES OUTPUT OF DIP LOC AND < > INDICATES PIN NUMBER

THIS DRAWING AND SPECIFICATIONS ARE THE PROPERTY OF DIGITAL EQUIPMENT CORPORATION AND SHALL NOT BE REPRODUCED OR COPIED OR USED IN WHOLE OR IN PART AS THE BASIS FOR THE MANUFACTURE OR SALE OF ITEMS WITHOUT WRITTEN PERMISSION. COPYRIGHT © 1979. DIGITAL EQUIPMENT CORPORATION.

REVISIONS		
CHK	CHANGE NO.	REV.

digital  
DATE: 01/22/79  
DRAWN: [Signature]  
ENGR: [Signature]  
DATE: 01/22/79  
BOARD LOCATION: 2 OF 2 SHEET  
FIRST USED ON OPTION/MODEL: MF20  
D-DD-M8577-0  
TITLE: RESISTOR DRAWING ADDRESS AND TIME  
SIZE CODE: D CS  
NUMBER: M8577-0-RES  
REV: A

REV. A  
D D CS M8577-0-RES

DRAWING NUMBER		NO. OF SHT	PART NUMBER	DESCRIPTION	REVISION	
					ORIG	M8570
						MR001
			M8570-AA	MODULE REVISION	A1	A1
E-UA-M8570-0-0		1		MF20 1024K MOS STORAGE	A	B
K-PL-M8570-0-DBP		4		PART LIST, M8570	A	B
D-CS-M8570-0-SM00		1		MOS STORAGE ARRAY BIT [T+00]	A	A
D-CS-M8570-0-SM01		1		MOS STORAGE ARRAY BIT [T+01]	A	A
D-CS-M8570-0-SM02		1		MOS STORAGE ARRAY BIT [T+02]	A	A
D-CS-M8570-0-SM03		1		MOS STORAGE ARRAY BIT [T+03]	A	A
D-CS-M8570-0-SM04		1		MOS STORAGE ARRAY BIT [T+04]	A	A
D-CS-M8570-0-SM05		1		MOS STORAGE ARRAY BIT [T+05]	A	A
D-CS-M8570-0-SM06		1		MOS STORAGE ARRAY BIT [T+06]	A	A
D-CS-M8570-0-SM07		1		MOS STORAGE ARRAY BIT [T+07]	A	A
D-CS-M8570-0-SM08		1		MOS STORAGE ARRAY BIT [T+08]	A	A
D-CS-M8570-0-SM09		1		MOS STORAGE ARRAY BIT [T+09]	A	A
D-CS-M8570-0-SM10		1		MOS STORAGE ARRAY BIT [T+10]	A	A
D-CS-M8570-0-SM11		1		MOS STORAGE WRITE PULSE LOGIC	A	A
D-CS-M8570-0-SM12		1		MOS STORAGE ROW ADDRESS STROBE	A	A
D-CS-M8570-0-SM13		1		MOS STORAGE COL ADDRESS STROBE	A	A
D-CS-M8570-0-SM14		1		MOS STORAGE ADDRESS CONTROL	A	A
D-CS-M8570-0-SM15		1		MOS STORAGE SM TERMINATORS	A	A
D-CS-M8570-0-SM16		1		MOS STORAGE GNDS, SPARE TERMS	A	A
D-CS-M8570-0-SM17		1		MOS STORAGE 5V PWR1/RAM CAPS	A	A
D-CS-M8570-0-SM18		1		MOS STORAGE 5V PWR2 / CNTL CAPS	A	A
D-CS-M8570-0-SM19		1		MOS STORAGE -5.2V/-2.0V CAPS	A	A
K-PC-M8570-0-DBI		-		P.C. DESIGN DATA BASE TAPE	B	B
D-DD-5016346-0		1		5016346 DRAWING DIRECTORY	REF	REF
A-SP-M8570-0-1		18		MG20M MOS MEMORY ENGINEERING SPEC	A	A

REVISIONS	
CHK	CHANGE NO. REV

digital	DRN. R. J. EICHMANN	DATE 20-10-85	ENG. R. J. EICHMANN	DATE 20-10-85	TITLE: M8570
	CHK'D R. H. CALINTER	DATE 20-10-85	BOARD LOCATION: N/A	DE 1	DRAWING DIRECTORY
DSK: M8570A.T2PL4.521		20-MAR-85 09:52	NEXT HIGHER ASSEMBLY:	SIZE CODE	NUMBER
FIRST USED ON OPTION/MODEL: MG20		NONE		D DD	M8570-0
					REV. B

REV. B  
 NUMBER M8570-0  
 CODE DD  
 SIZE D

MAO 1

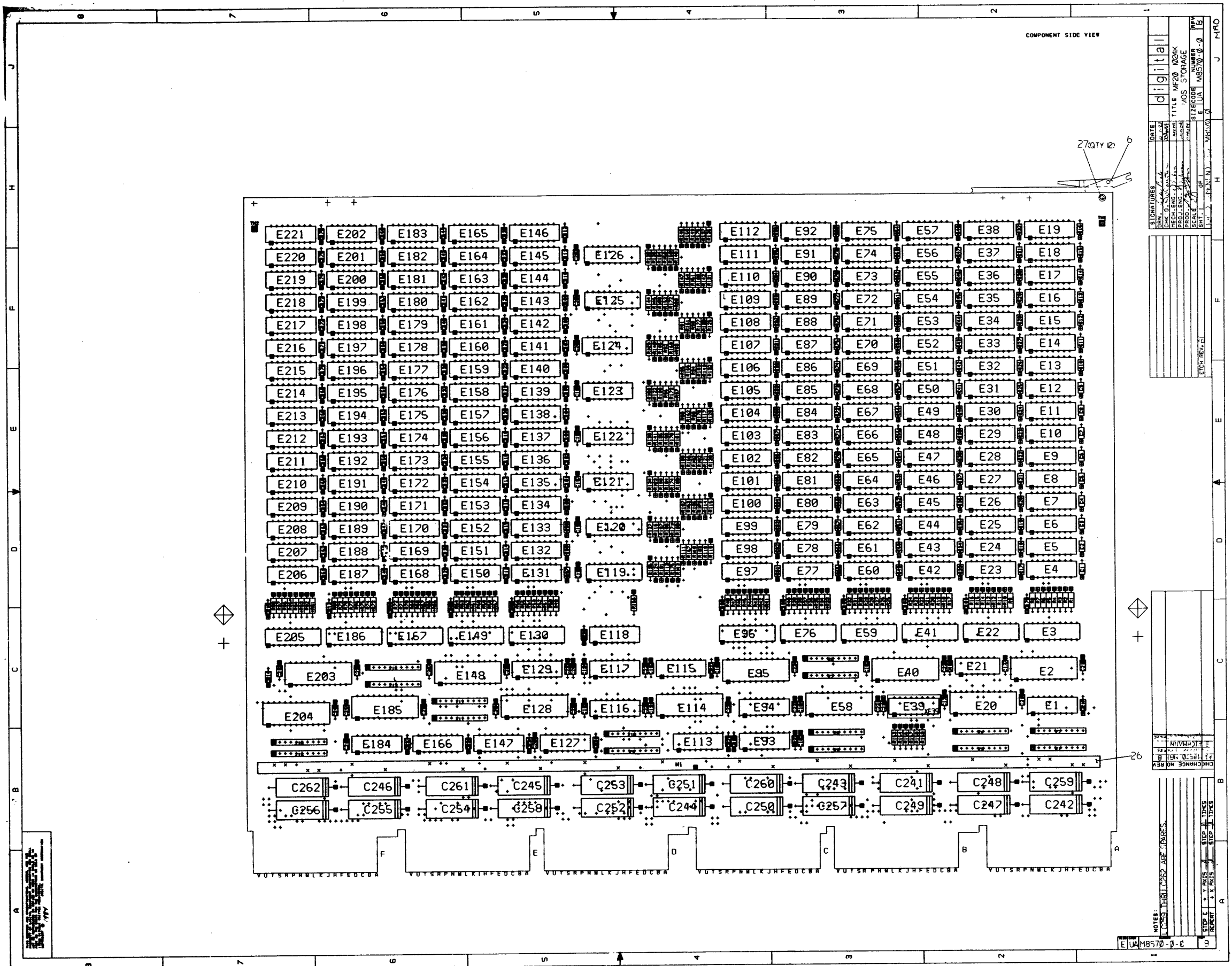

COMPONENT SIDE VIEW

DATE	10/24/77	REV	0
DRN.	W. J. J.	CHK. BY	W. J. J.
RECH. ENG.	W. J. J.	SCALE	1:1
PROD. BY	W. J. J.	SIZE CODE	1024K
TITLE	DIGITAL / AOS STORAGE		
REV.	0	NUMBER	19
REV.	0	NUMBER	19

DATE	10/24/77	REV	0
DRN.	W. J. J.	CHK. BY	W. J. J.
RECH. ENG.	W. J. J.	SCALE	1:1
PROD. BY	W. J. J.	SIZE CODE	1024K
TITLE	DIGITAL / AOS STORAGE		
REV.	0	NUMBER	19
REV.	0	NUMBER	19

DATE	10/24/77	REV	0
DRN.	W. J. J.	CHK. BY	W. J. J.
RECH. ENG.	W. J. J.	SCALE	1:1
PROD. BY	W. J. J.	SIZE CODE	1024K
TITLE	DIGITAL / AOS STORAGE		
REV.	0	NUMBER	19
REV.	0	NUMBER	19

2-0-0158M13

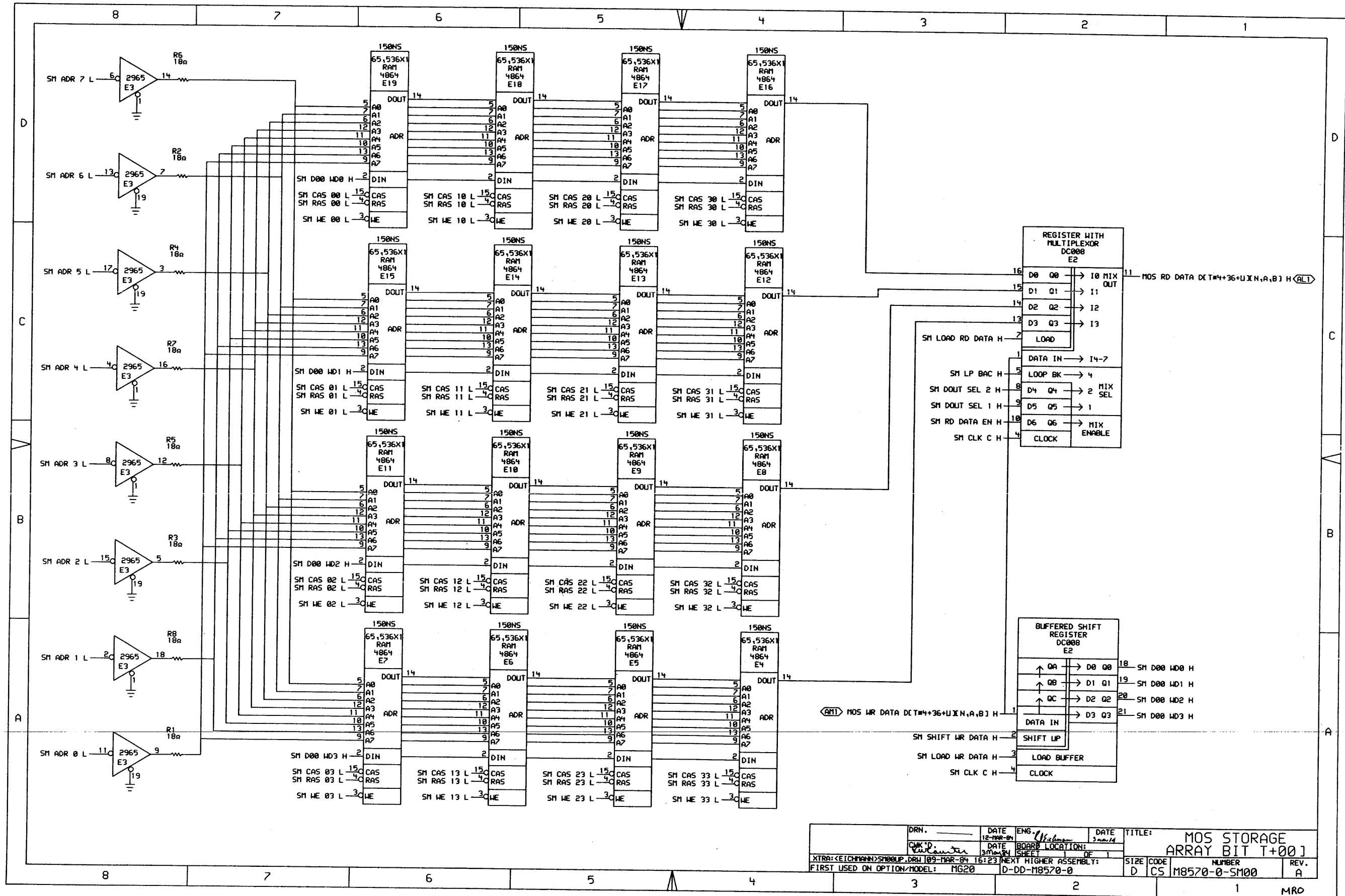

DRN.	DATE	ENG.	DATE	TITLE:
	12-MAR-84	W. S. ...	3-MAR-84	MOS STORAGE ARRAY BIT T+001
CHK'D.	DATE	BOARD LOCATION:		
W. S. ...	3-MAR-84			
XTRA: (EICHMANN) SMOBUP.DRW 109-MAR-84 16:23 NEXT HIGHER ASSEMBLY:				SIZE
FIRST USED ON OPTION/MODEL: MG20				D-DD-M8570-0
		NUMBER	REV.	
		D C5 M8570-0-SM00	A	

MRO

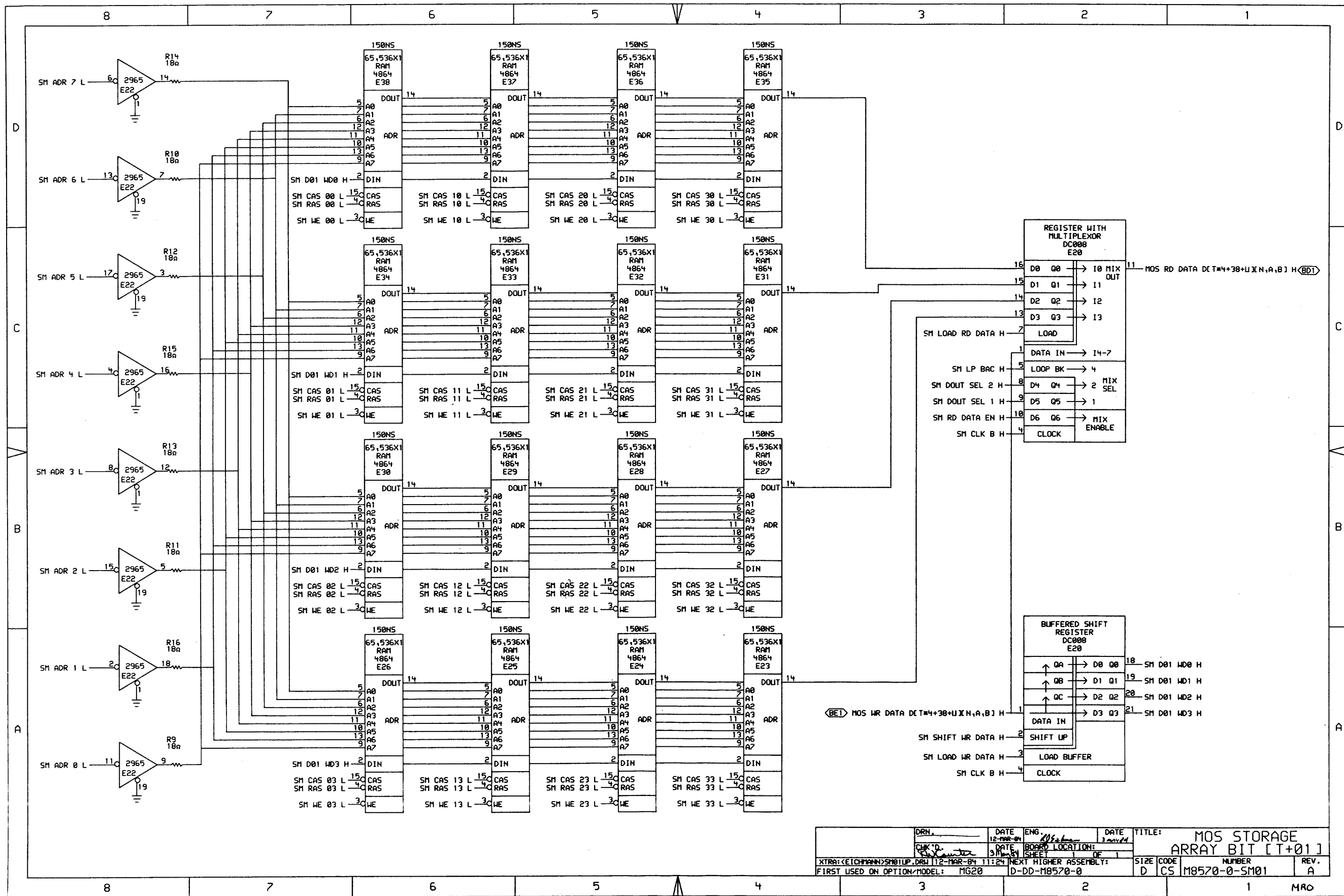

DRN.	DATE	ENG.	DATE	TITLE:
	12-MAR-84	W. Schuman	3-MAR-84	MOS STORAGE
CHK'D.	DATE	BOARD LOCATION:		ARRAY BIT [T+01]
	3-MAR-84	SHEET 1 OF 1		
NEXT HIGHER ASSEMBLY:				SIZE CODE
FIRST USED ON OPTION/MODEL: MG20				D C5
				NUMBER
				M8570-0-SM01
				REV.
				A

MRO

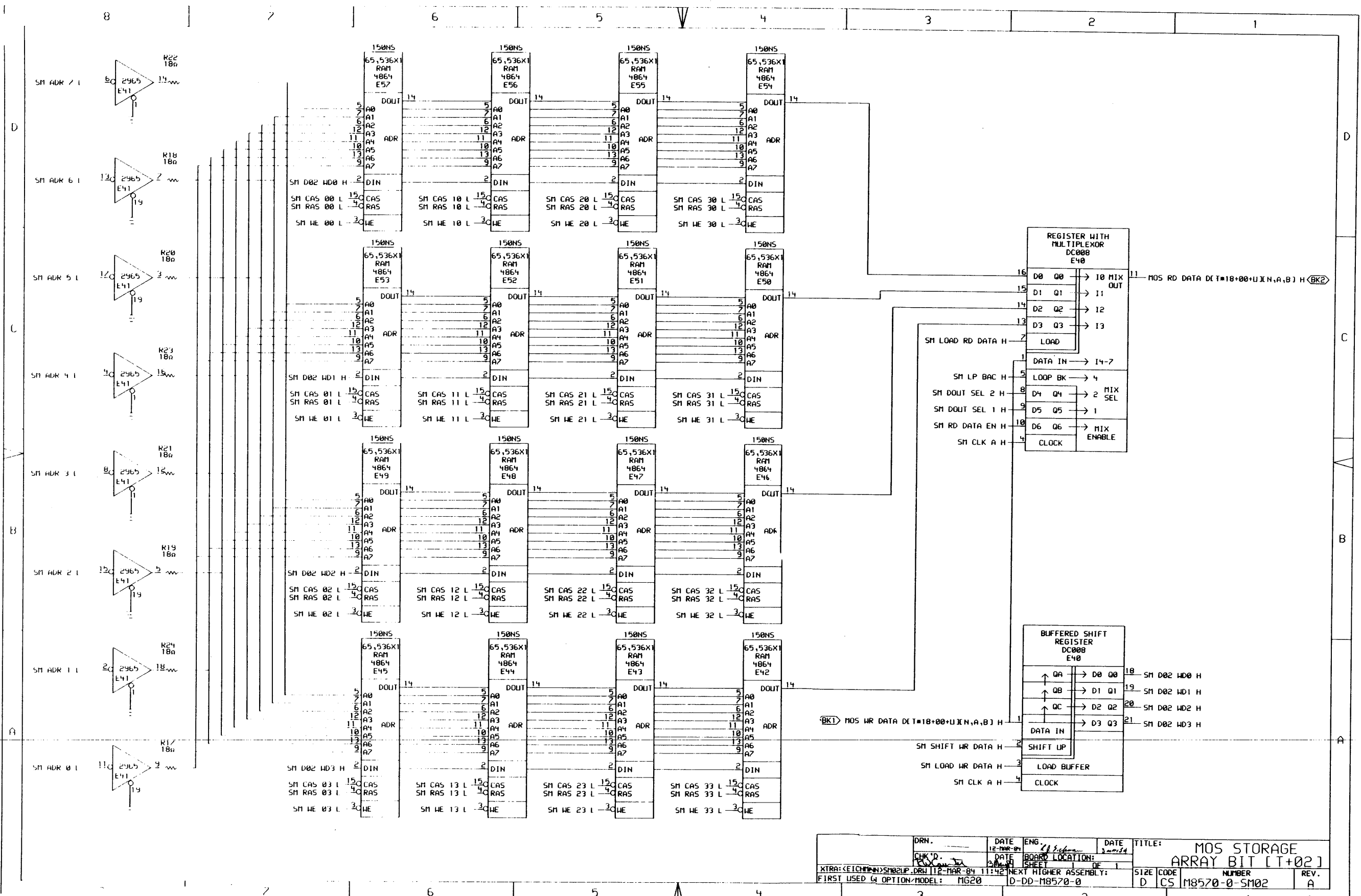

DRN.	DATE	ENG.	DATE	TITLE:
CHK'D.	12-MAR-84	W. J. ...	3-MAR-84	MOS STORAGE
DATE	BOARD LOCATION:	DATE	DATE	ARRAY BIT [T+02]
12-MAR-84	11:42	11:42	11:42	
NEXT HIGHER ASSEMBLY:				SIZE CODE
D-DD-M8570-0				D CS
NUMBER				REV.
M8570-0-SM02				A
MRO				

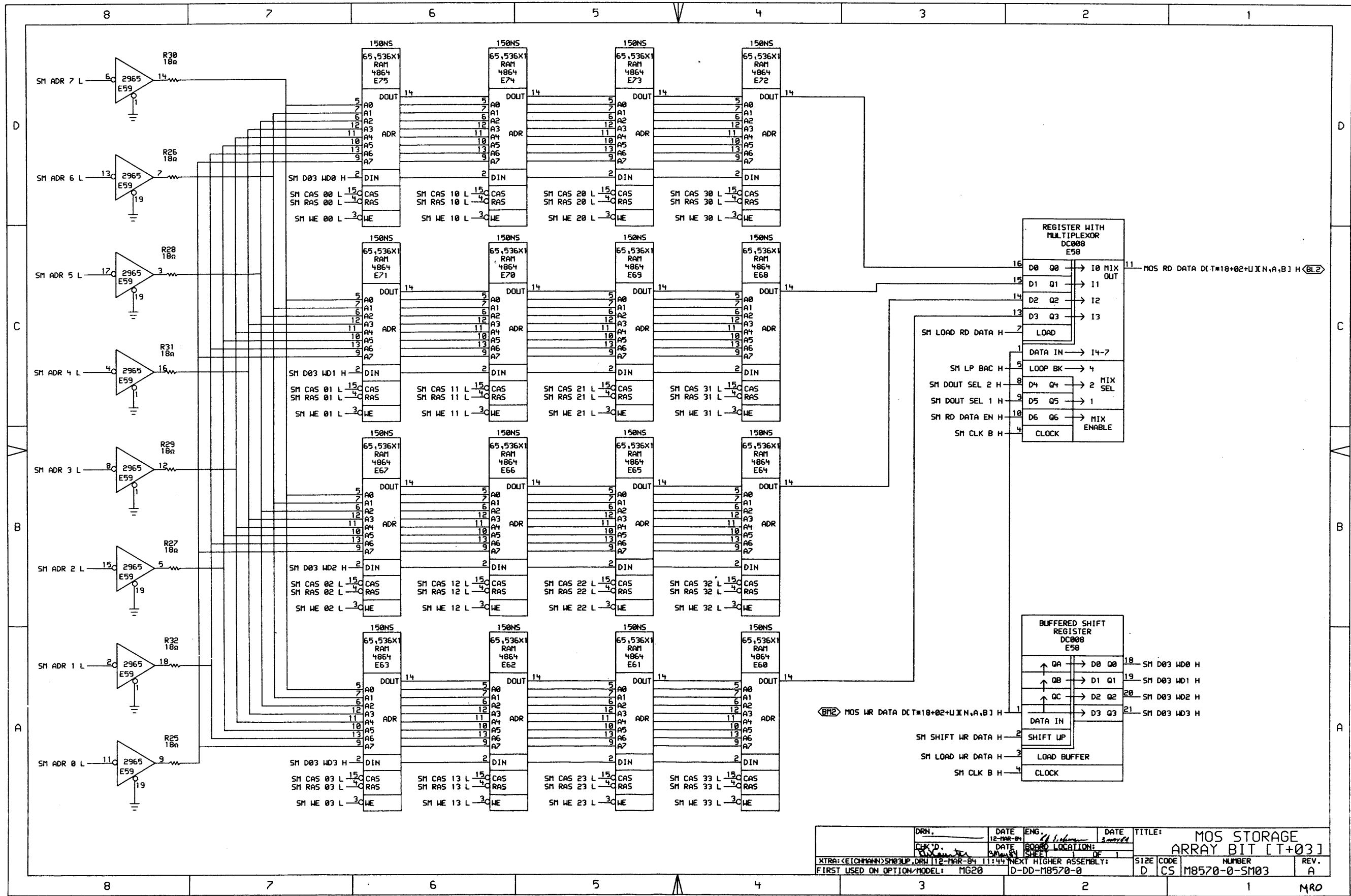

DRN.	DATE	ENG.	DATE	TITLE:
CHK'D.	12-1988-04	J. L. Johnson	3-1989	MOS STORAGE ARRAY BIT [T+03]
DATE	BOARD LOCATION:	SHEET	OF	
12-1988-04	DE 1	1	1	
XTRA: <EICHMANN> SM03LP.DRW [12-MAR-84 11:44] NEXT HIGHER ASSEMBLY:				SIZE CODE NUMBER REV.
FIRST USED ON OPTION/MODEL: MG20 D-DD-M8570-0				D CS M8570-0-SM03 A

MRO

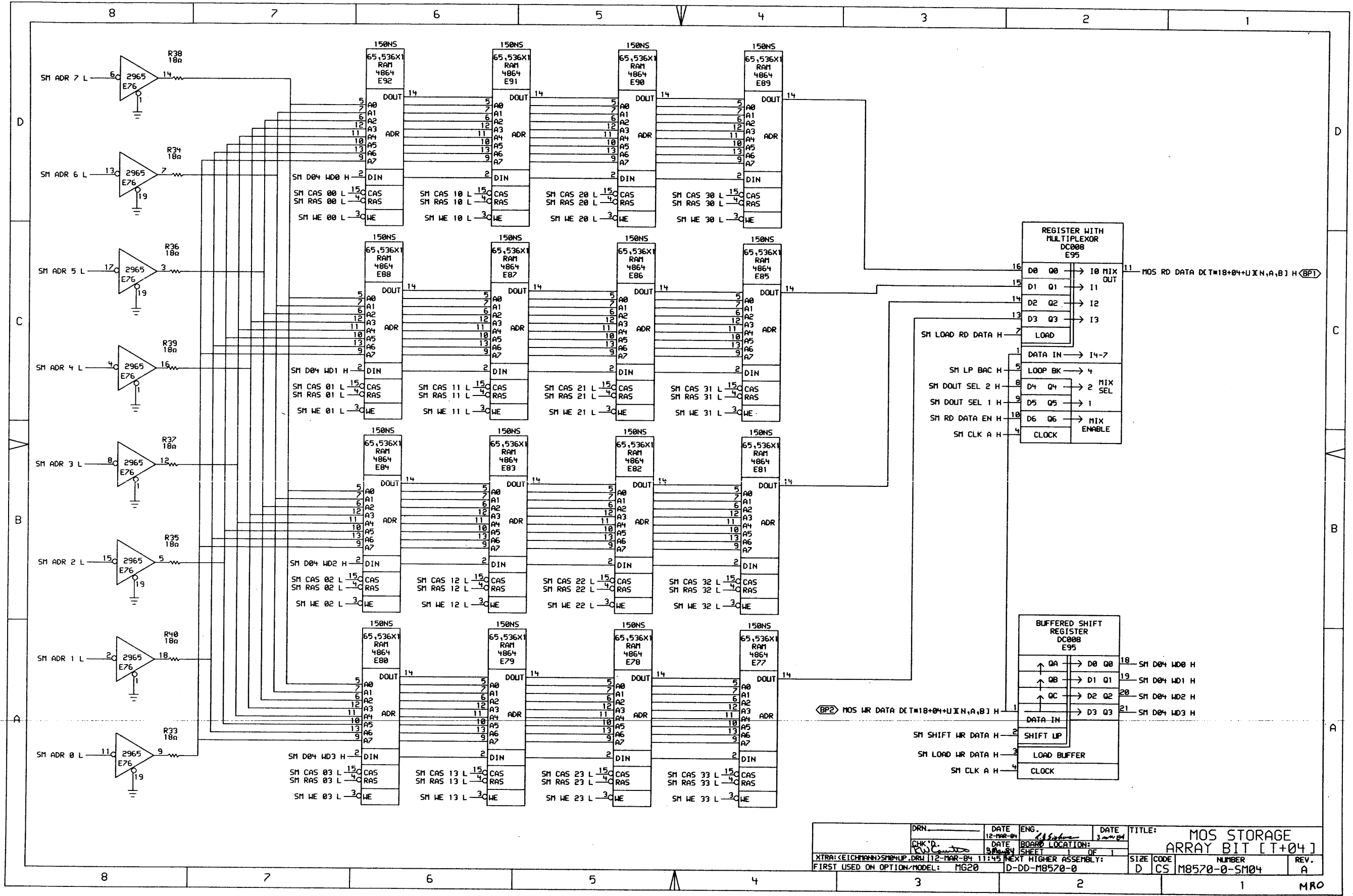

DRN	DATE	ENG.	DATE	TITLE:
CHK'D.	12-MAR-84		3-MAR-84	MOS STORAGE
				ARRAY BIT [T+04]
XTRA: <EICHMANN> SM04LUP.DRW 112-MAR-84 11:45 NEXT HIGHER ASSEMBLY:				SIZE CODE NUMBER REV.
FIRST USED ON OPTION/MODEL: MG20 D-DD-M8570-0				D CS M8570-0-SM04 A

MRO

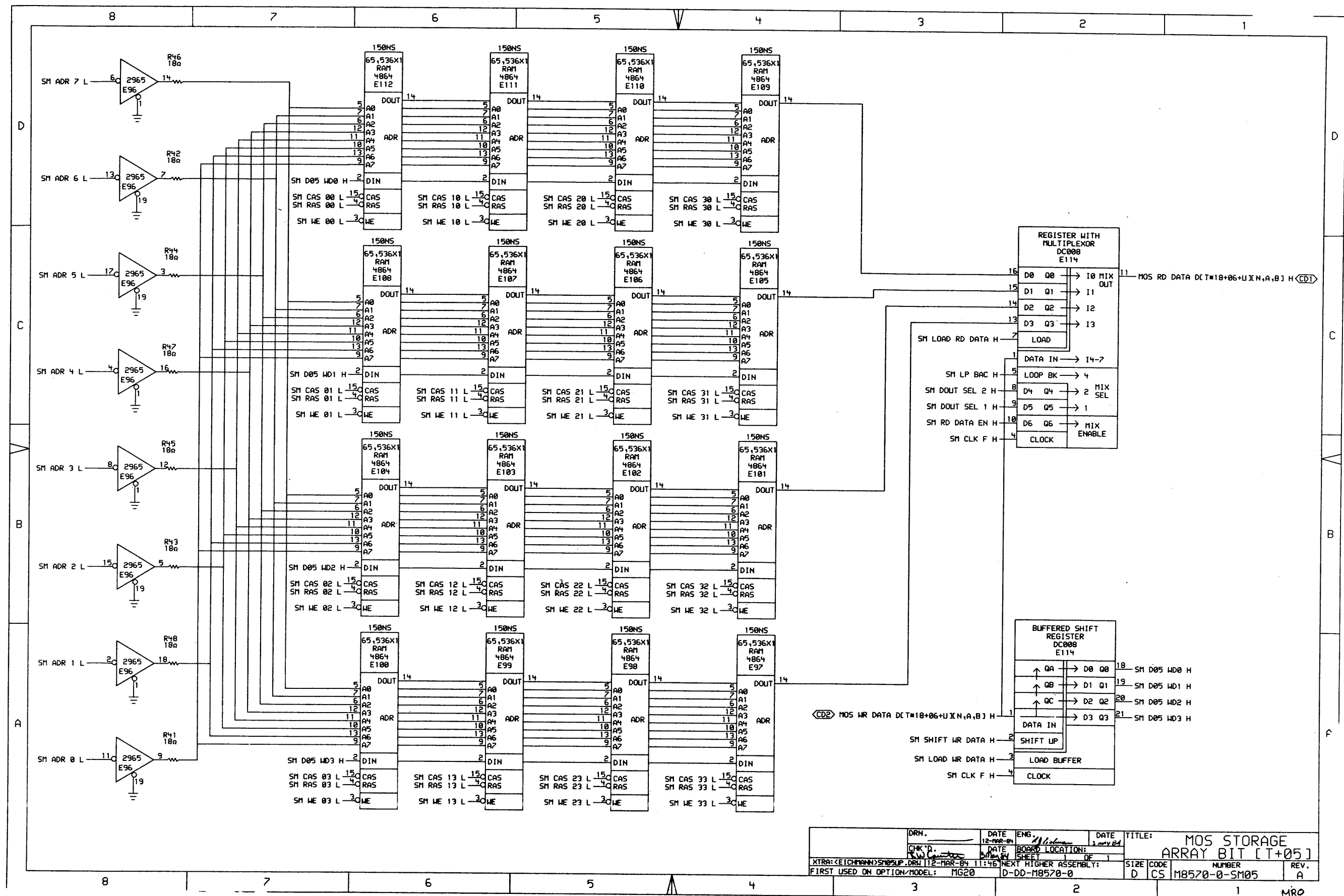

DRN.	DATE	ENG.	DATE	TITLE:
CHK'D.	12-MAR-84	M. Wilson	3-MAR-84	MOS STORAGE
DATE	BOARD LOCATION:	REV.		ARRAY BIT [T+05]
11-MAR-84	DEF 1			
XTRA: (EICHMANN) SMO SUP. DRW 112-MAR-84 11:46 NEXT HIGHER ASSEMBLY:				SIZE CODE
FIRST USED ON OPTION/MODEL: MG20 D-DD-M8570-0				NUMBER
				D CS M8570-0-SM05
				REV. A

MRO

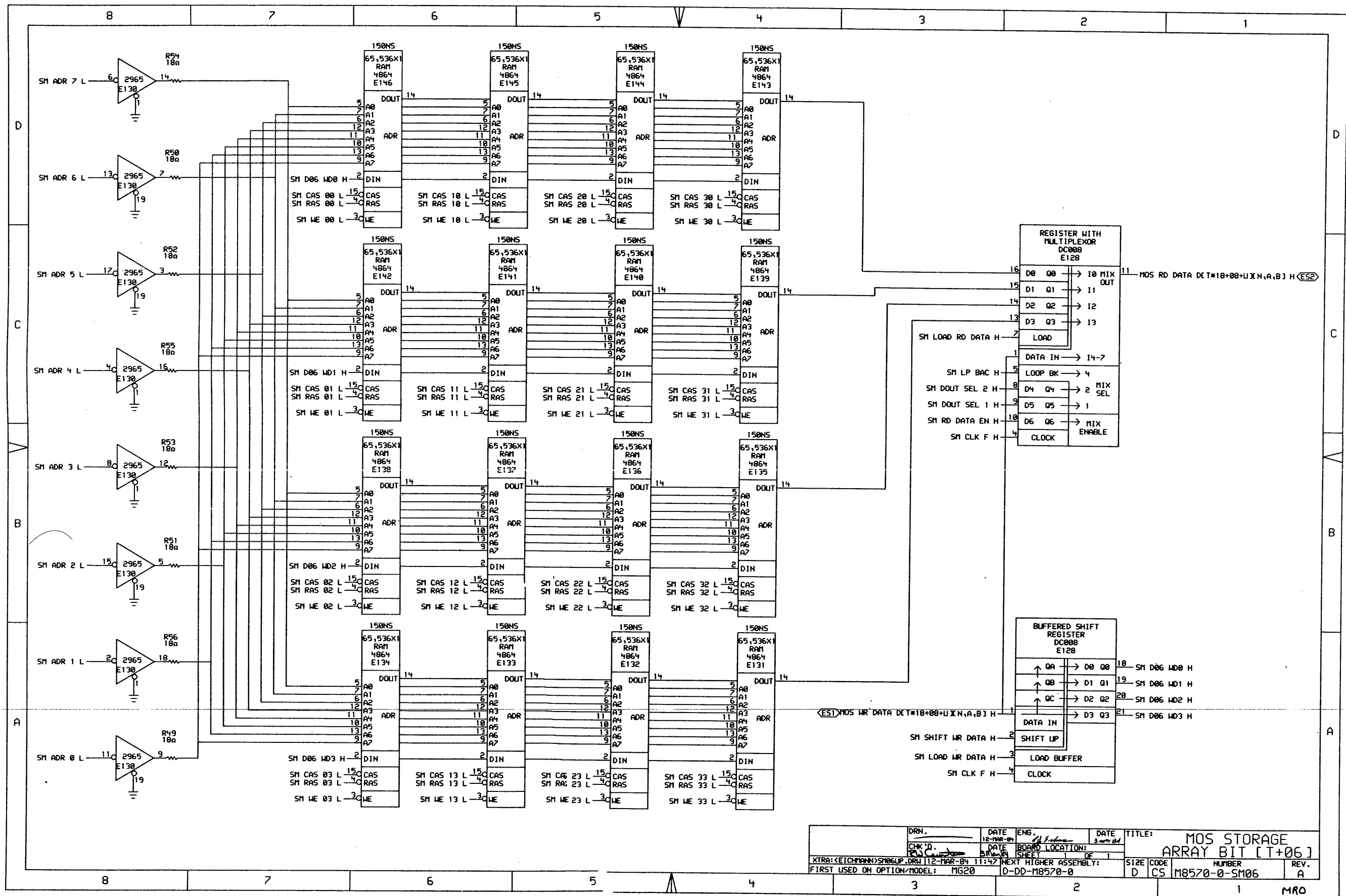

DRN.	DATE	ENG.	DATE	TITLE:
CHK'D.	12-MAR-84	W. Fisher	3-MAR-84	MOS STORAGE
REV. C	DATE	BOARD LOCATION:	SHEET	ARRAY BIT [T+06]
	12-MAR-84	11:47	1	
FIRST USED ON OPTION/MODEL: M620		NEXT HIGHER ASSEMBLY: D-DD-M8570-0		SIZE CODE NUMBER REV.
				D CS M8570-0-SM06 A

MRO

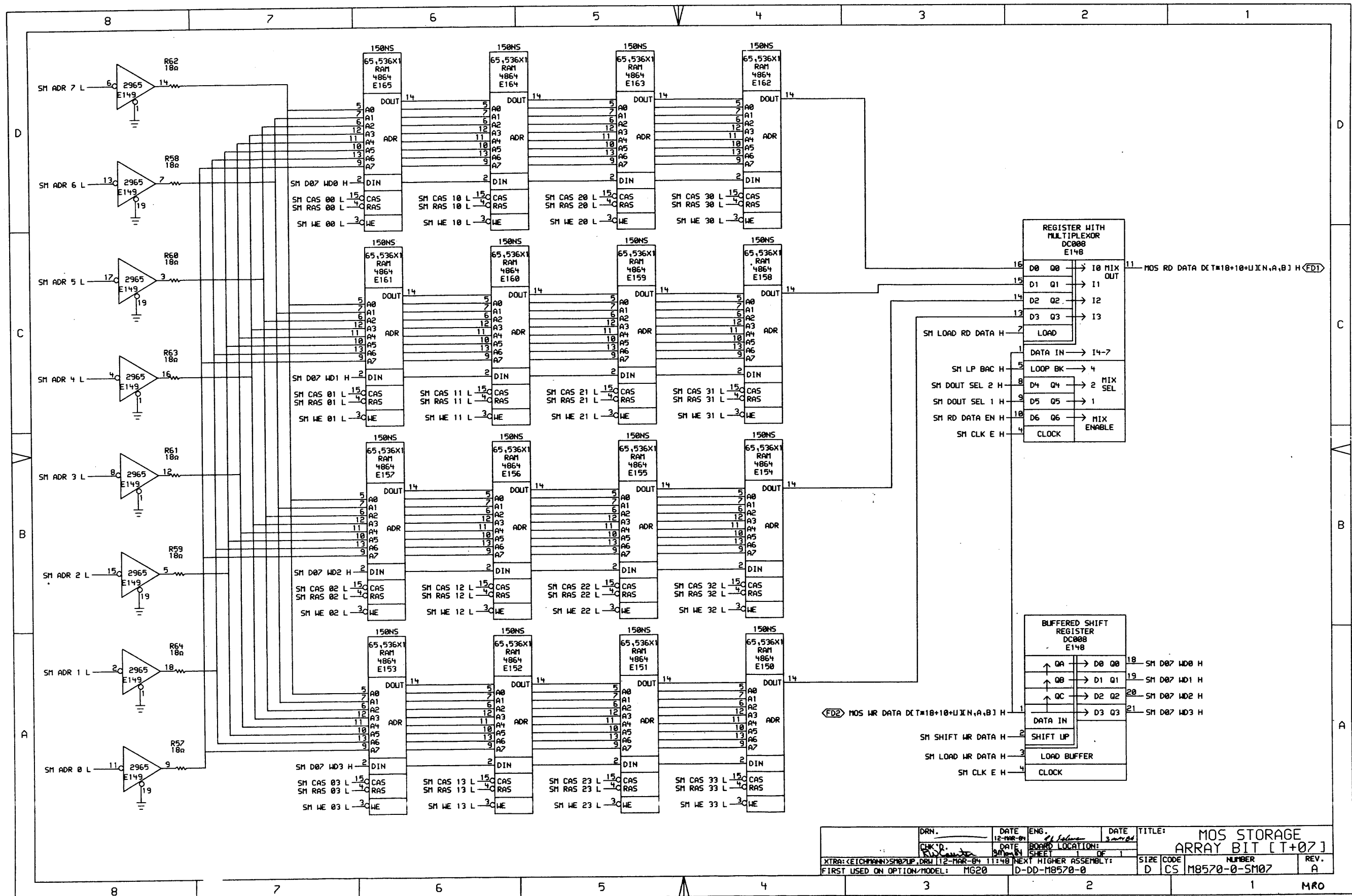

DRN.	DATE	ENG.	DATE	TITLE:
	12-MAR-84	J. J. Sullivan	3-MAR-84	MOS STORAGE ARRAY BIT [T+07]
CHK'D.	DATE	BOARD LOCATION:	SHEET	OF
	30-MAR-84		1	1
XTRA: (EICHMANN) SHIP, DRU 112-MAR-84 11:48				NEXT HIGHER ASSEMBLY:
FIRST USED ON OPTION/MODEL: MG20				D-DD-M8570-0
SIZE	CODE	NUMBER	REV.	
D	CS	M8570-0-S107	A	

MRO

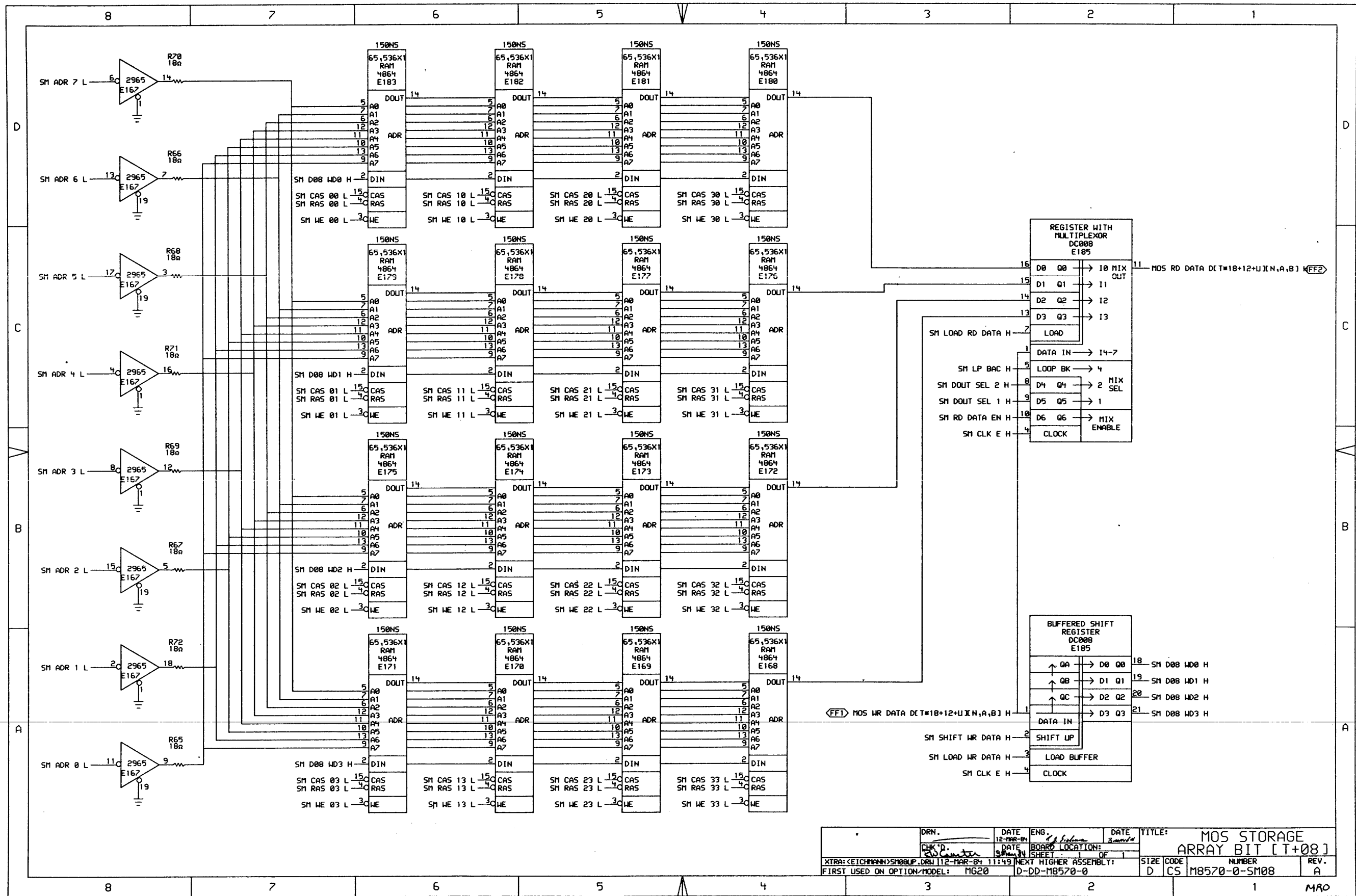

DRN.	DATE	ENG.	DATE	TITLE:
CHK'D.	12-MAR-84	A. S. S.	3/20/84	MOS STORAGE ARRAY BIT [T+08]
XTRA: <EICHMANN> SMOBUP.DRW	112-MAR-84	11:49	NEXT HIGHER ASSEMBLY:	SIZE CODE NUMBER
FIRST USED ON OPTION MODEL:	MG20	D-DD-M8570-0		D CS M8570-0-SM08

REV. A

MA0

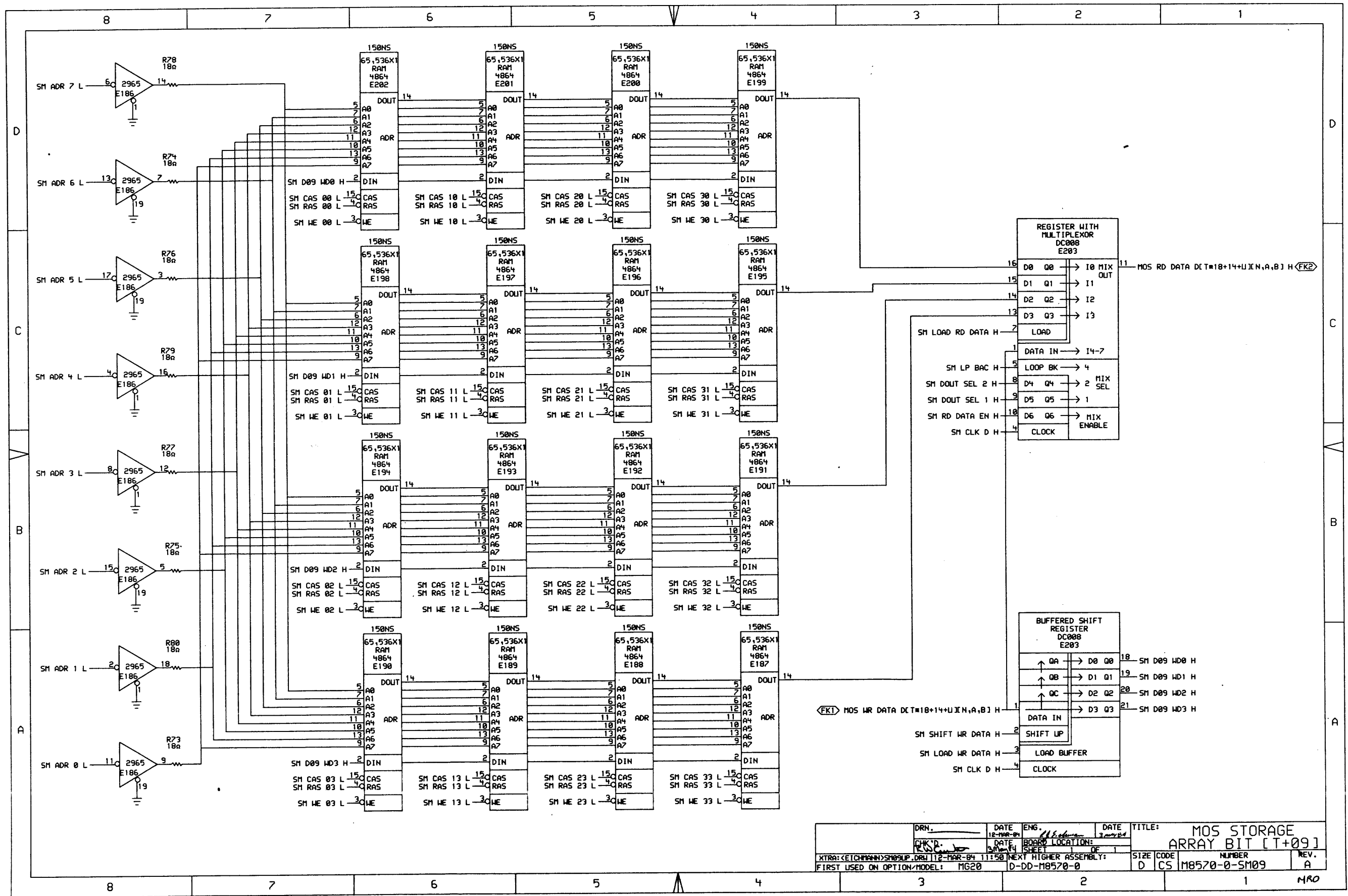

DRN.	DATE	ENG.	DATE	TITLE:
CHK'D.	12-1988-04	M. Johnson	3-20-89	MOS STORAGE
DATE	3-20-89	BOARD LOCATION:	DE	ARRAY BIT [T+09]
SHEET	4	DATE	DE	
NEXT HIGHER ASSEMBLY:				SIZE CODE
FIRST USED ON OPTION/MODEL: MG20				D CS
				NUMBER
				M8570-0-SM09
				REV.
				A

MRO

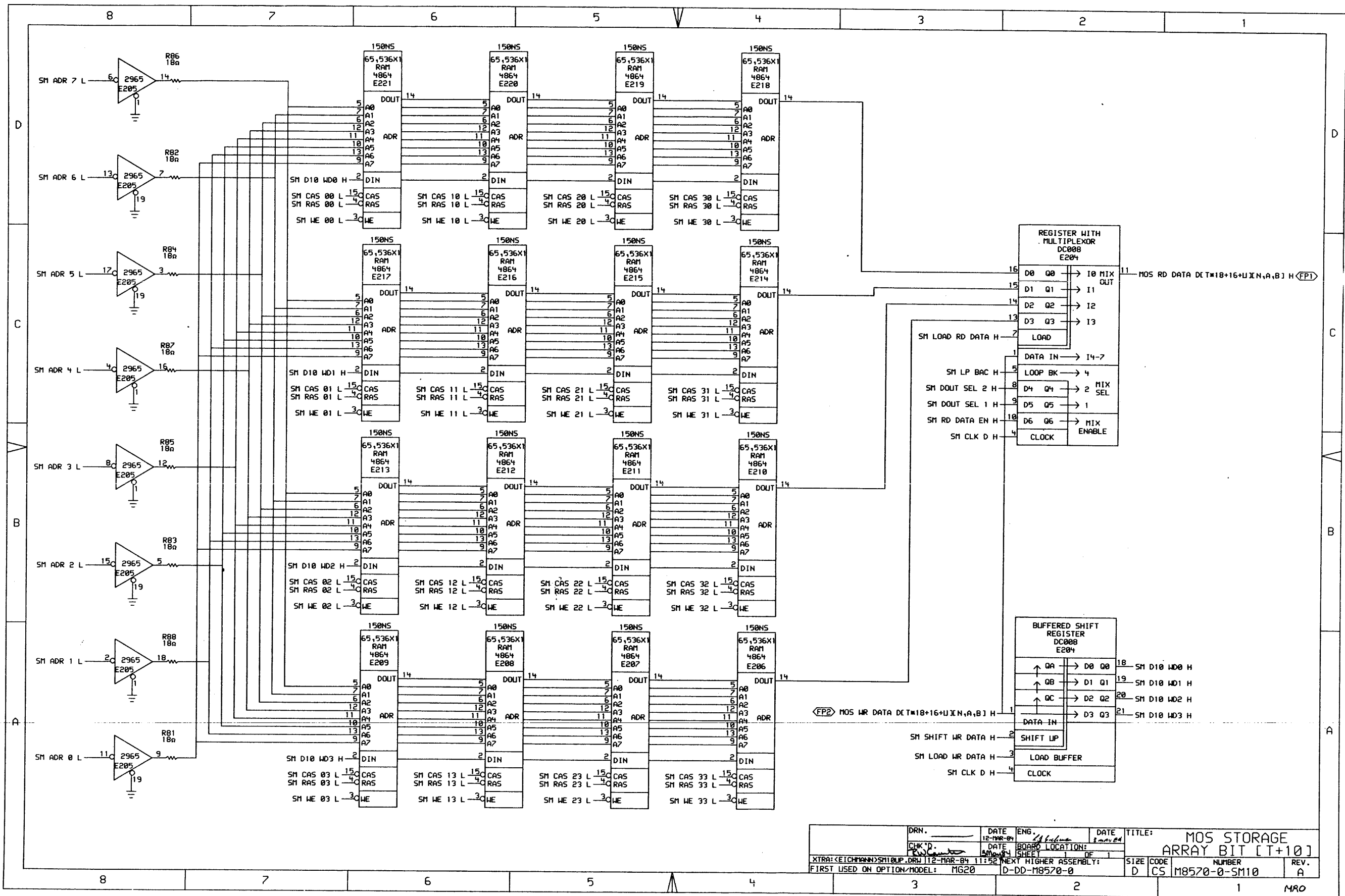

DRN.	DATE	ENG.	DATE	TITLE:
CHK'D.	12-MAR-84	W. Williams	8-Mar-84	MOS STORAGE
				ARRAY BIT [T+10]
XTRA: <EICHMANN> SM10LP.DRW 12-MAR-84 11:52 NEXT HIGHER ASSEMBLY:				SIZE CODE NUMBER REV.
FIRST USED ON OPTION/MODEL: MG20 D-DD-M8570-0				D CS M8570-0-SM10 A

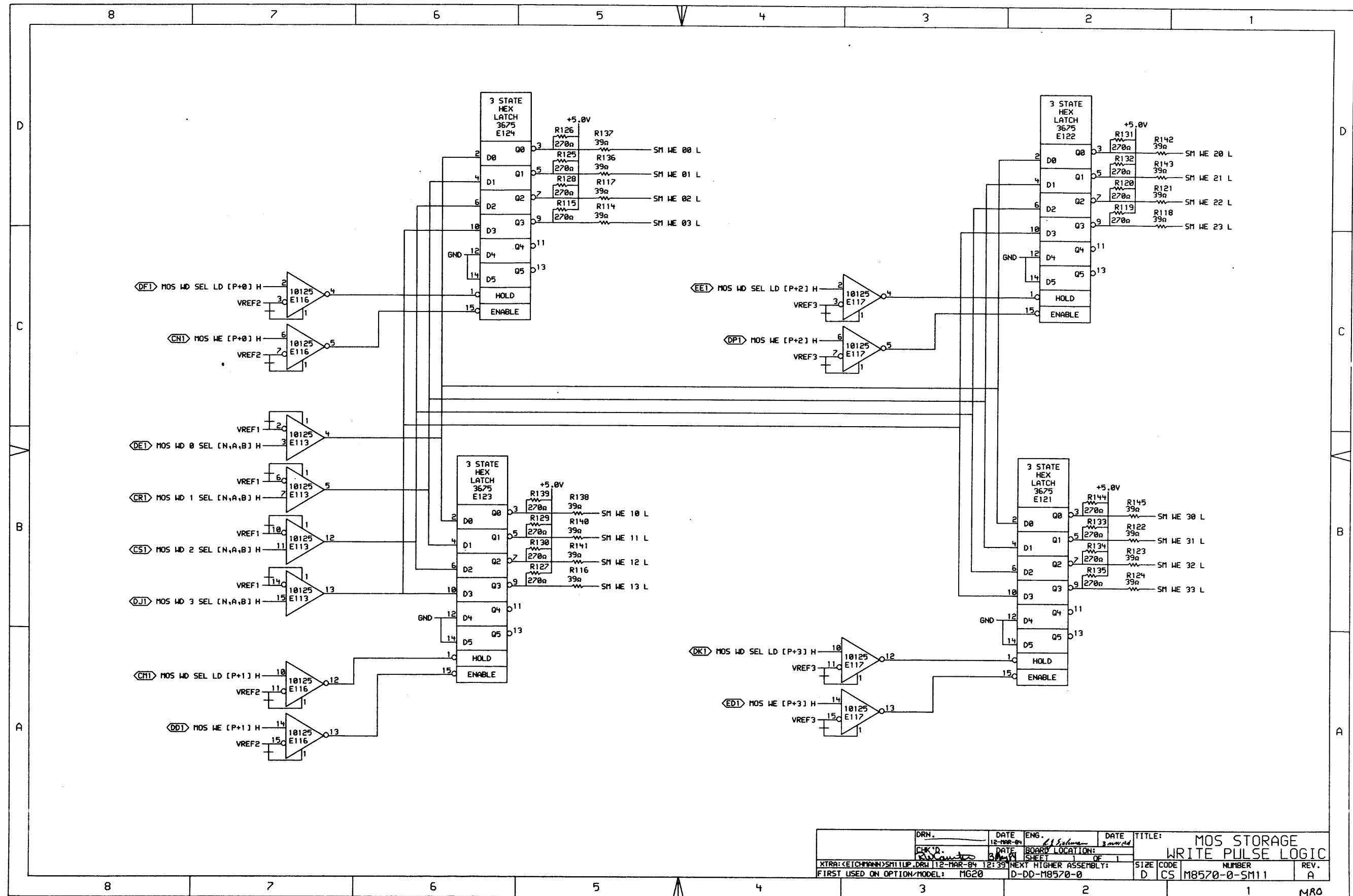

DRN.	DATE	ENG.	DATE	TITLE:
CHK'D.	12-1988-84	<i>[Signature]</i>	3-1989-84	MOS STORAGE WRITE PULSE LOGIC
XTRA: (EICHMANN) SM11UP.DRW	DATE	BOARD LOCATION:	SIZE	CODE
FIRST USED ON OPTION/MODEL: MG20	12-MAR-84 12:39	DE-1	D	CS
		NEXT HIGHER ASSEMBLY:	NUMBER	REV.
		D-DD-M8570-0	M8570-0-SM11	A

MRO

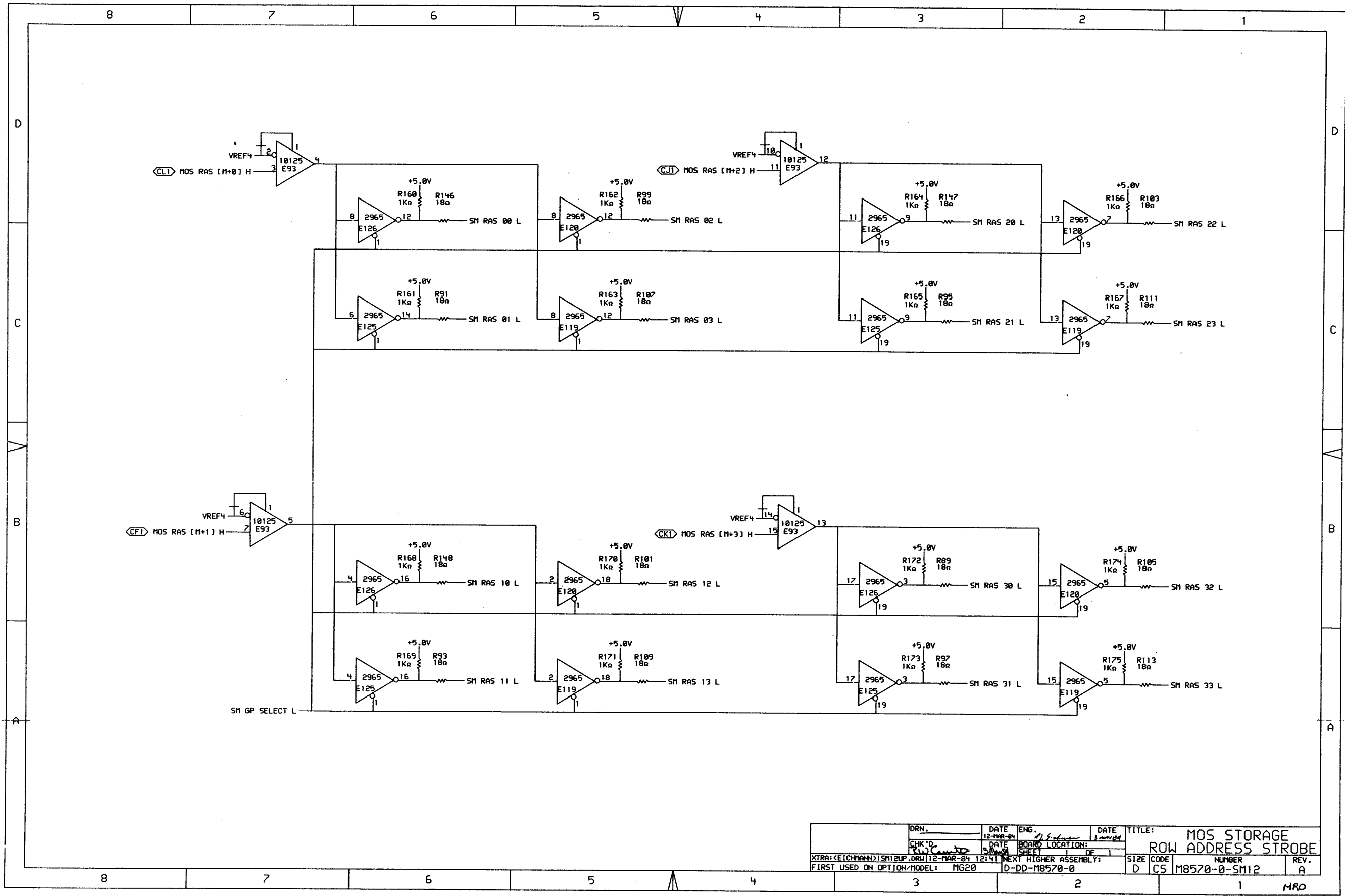

DRN.	DATE	ENG.	DATE	TITLE:
CHK'D	12-MAR-84	<i>[Signature]</i>	3-MAR-84	MOS STORAGE
XTRA: <EICHMANN>   SHIPUP.DRW   12-MAR-84   12:41	DATE	BOARD LOCATION:	SHEET	ROW ADDRESS STROBE
FIRST USED ON OPTION/MODEL: MG20	D-DD-M8570-0	SIZE	CODE	NUMBER
		D	CS	M8570-0-SM12
				REV. A

MRO

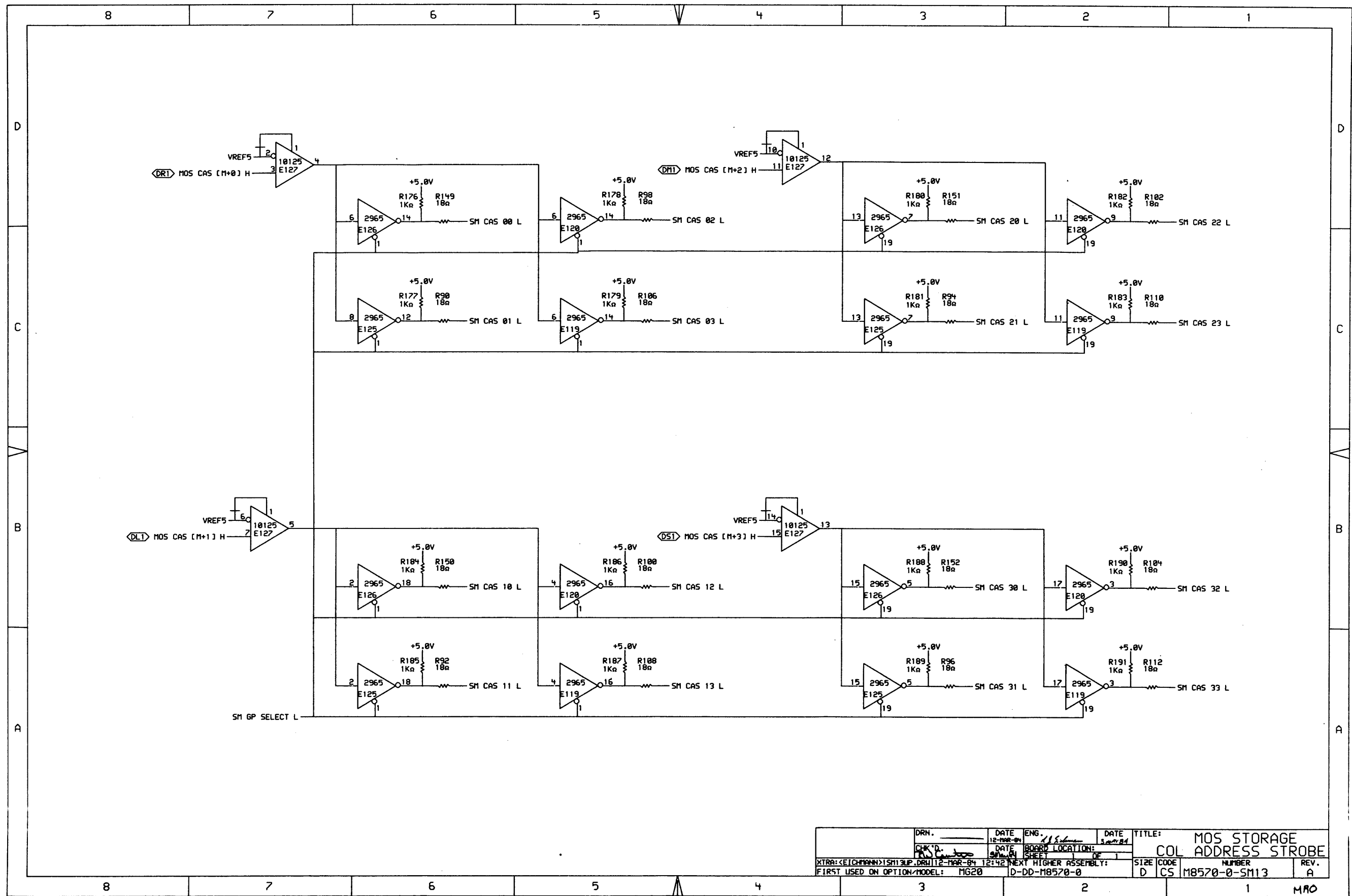

DRN.	DATE	ENG.	DATE	TITLE:
CHK'D.	DATE	BOARD LOCATION:		MOS STORAGE
EXTRA: EICHMANN	12-1988-04	3000		COL ADDRESS STROBE
FIRST USED ON OPTION/MODEL:	12:42	NEXT HIGHER ASSEMBLY:		NUMBER
MG20	D-DD-M8570-0			REV.
				A

MRO

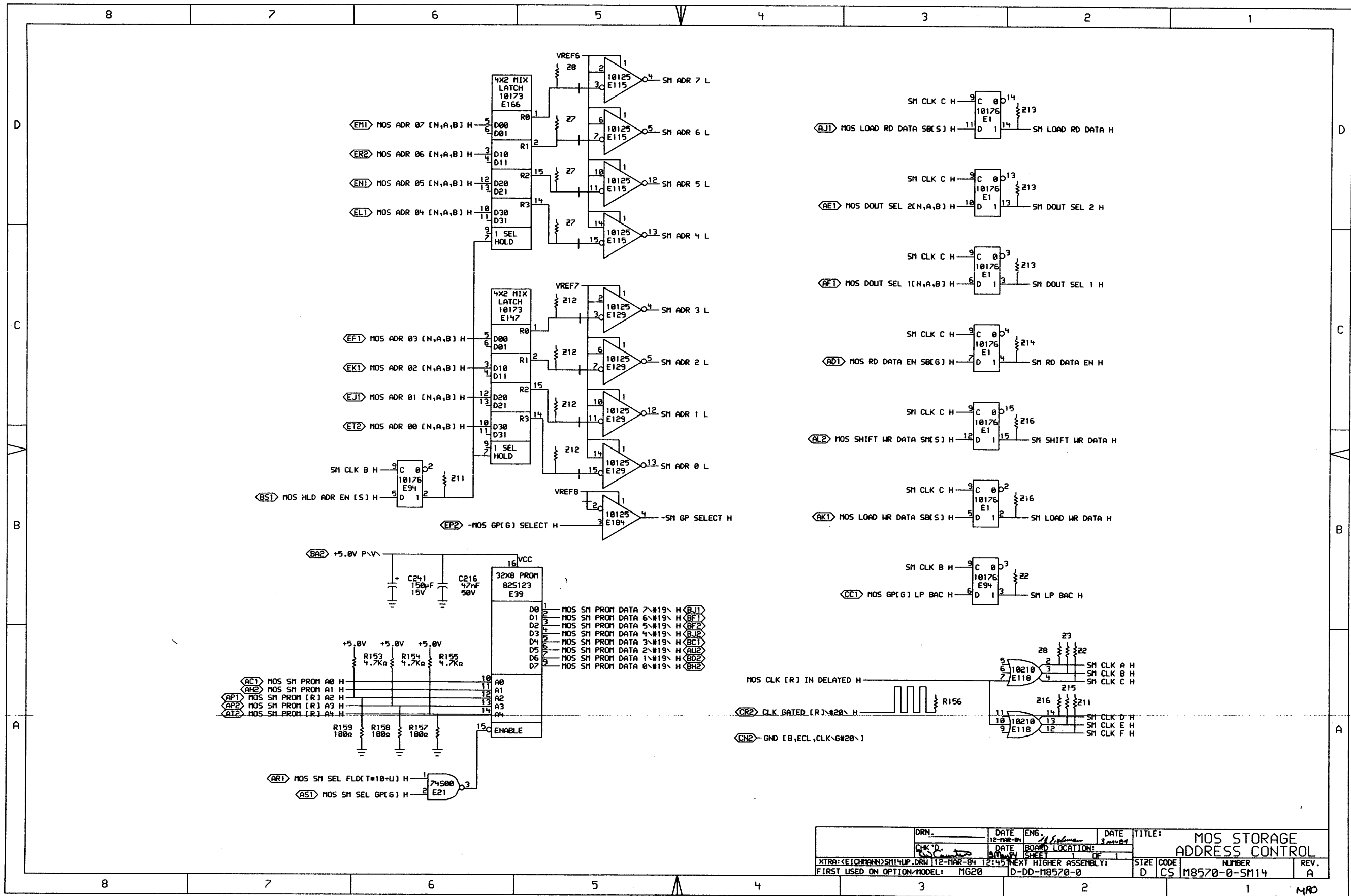

DRN.	DATE	ENG.	DATE	TITLE:		
	12-MAR-84	J. K. ...	3-24-84	MOS STORAGE ADDRESS CONTROL		
CHK'D.	DATE	BOARD LOCATION:	SIZE CODE NUMBER REV.			
			D	CS	M8570-0-SM14	A
XTRA: (EICHMANN) SM14UP.DRW 12-MAR-84 12:45 NEXT HIGHER ASSEMBLY:				FIRST USED ON OPTION/MODEL: MG20 D-DD-M8570-0		

MRO

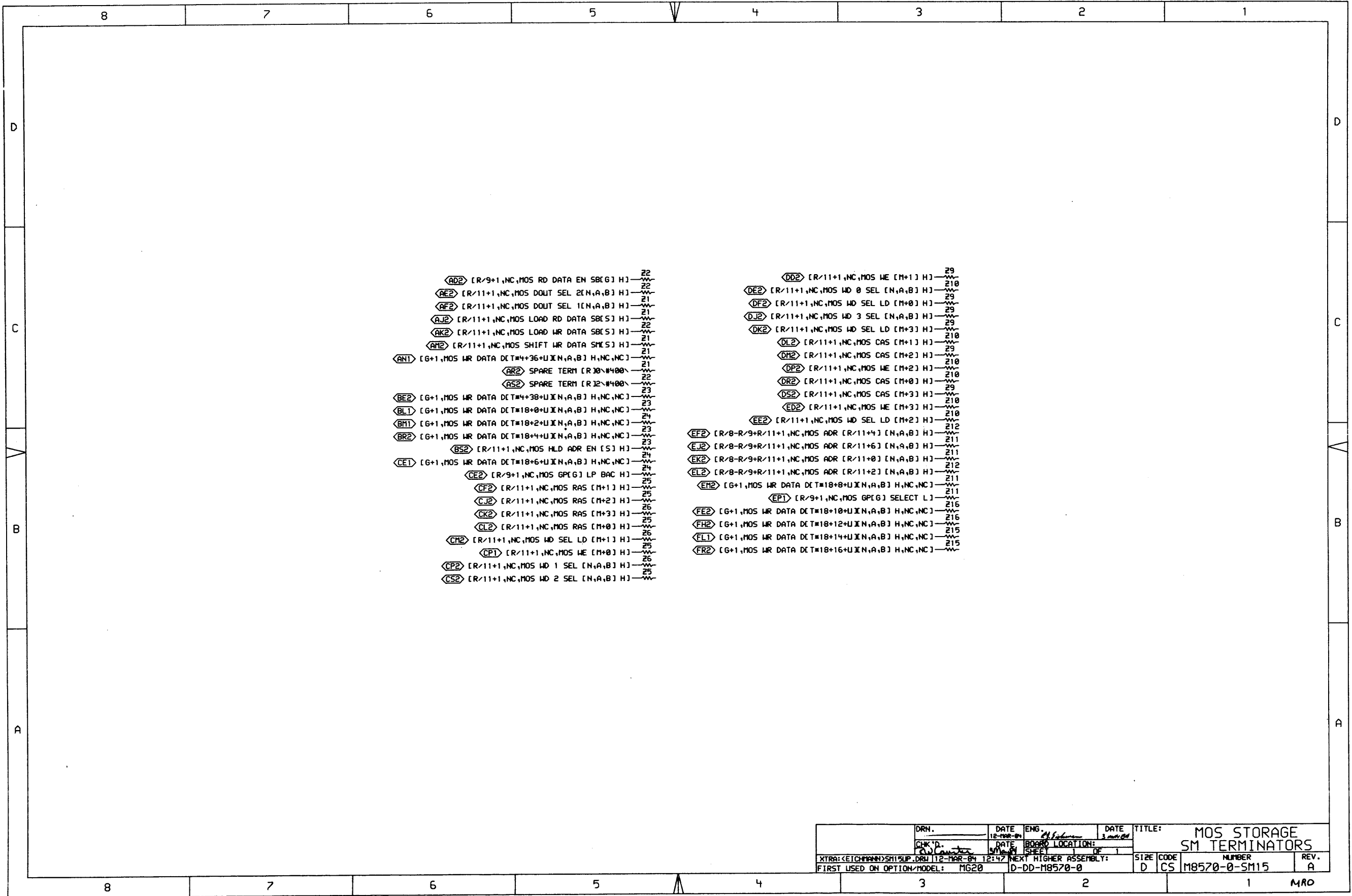

AD2 [R/9+1,NC,MOS RD DATA EN SBEG] H) 22  
 AE2 [R/11+1,NC,MOS DOUT SEL 2(N,A,B)] H) 21  
 AF2 [R/11+1,NC,MOS DOUT SEL 1(N,A,B)] H) 21  
 AJ2 [R/11+1,NC,MOS LOAD RD DATA SBEG] H) 22  
 AK2 [R/11+1,NC,MOS LOAD WR DATA SBEG] H) 21  
 AM2 [R/11+1,NC,MOS SHIFT WR DATA SMES] H) 21  
 AN1 [G+1,MOS WR DATA DET#4+36+UJIN,A,B] H,NC,NC) 21  
 AR2 SPARE TERM [R]0#400 22  
 AS2 SPARE TERM [R]2#400 23  
 BE2 [G+1,MOS WR DATA DET#4+38+UJIN,A,B] H,NC,NC) 23  
 BL1 [G+1,MOS WR DATA DET#18+0+UJIN,A,B] H,NC,NC) 23  
 BM1 [G+1,MOS WR DATA DET#18+2+UJIN,A,B] H,NC,NC) 23  
 BR2 [G+1,MOS WR DATA DET#18+4+UJIN,A,B] H,NC,NC) 23  
 BS2 [R/11+1,NC,MOS HLD ADR EN [S] H) 24  
 CE1 [G+1,MOS WR DATA DET#18+6+UJIN,A,B] H,NC,NC) 24  
 CE2 [R/9+1,NC,MOS GPIG] LP BAC H) 25  
 CF2 [R/11+1,NC,MOS RAS [M+1] H) 25  
 CJ2 [R/11+1,NC,MOS RAS [M+2] H) 26  
 CK2 [R/11+1,NC,MOS RAS [M+3] H) 26  
 CL2 [R/11+1,NC,MOS RAS [M+0] H) 26  
 CH2 [R/11+1,NC,MOS WD SEL LD [M+1] H) 26  
 CP1 [R/11+1,NC,MOS WE [M+0] H) 26  
 CP2 [R/11+1,NC,MOS WD 1 SEL [N,A,B] H) 25  
 CS2 [R/11+1,NC,MOS WD 2 SEL [N,A,B] H) 25

DD2 [R/11+1,NC,MOS WE [M+1] H) 29  
 DE2 [R/11+1,NC,MOS WD 0 SEL [N,A,B] H) 210  
 DF2 [R/11+1,NC,MOS WD SEL LD [M+0] H) 29  
 DJ2 [R/11+1,NC,MOS WD 3 SEL [N,A,B] H) 29  
 DK2 [R/11+1,NC,MOS WD SEL LD [M+3] H) 29  
 DL2 [R/11+1,NC,MOS CAS [M+1] H) 210  
 DM2 [R/11+1,NC,MOS CAS [M+2] H) 29  
 DP2 [R/11+1,NC,MOS WE [M+2] H) 210  
 DR2 [R/11+1,NC,MOS CAS [M+0] H) 210  
 DS2 [R/11+1,NC,MOS CAS [M+3] H) 29  
 ED2 [R/11+1,NC,MOS WE [M+3] H) 210  
 EE2 [R/11+1,NC,MOS WD SEL LD [M+2] H) 210  
 EF2 [R/8-R/9+R/11+1,NC,MOS ADR [R/11+4] [N,A,B] H) 212  
 EJ2 [R/8-R/9+R/11+1,NC,MOS ADR [R/11+6] [N,A,B] H) 211  
 EK2 [R/8-R/9+R/11+1,NC,MOS ADR [R/11+0] [N,A,B] H) 211  
 EL2 [R/8-R/9+R/11+1,NC,MOS ADR [R/11+2] [N,A,B] H) 212  
 EM2 [G+1,MOS WR DATA DET#18+8+UJIN,A,B] H,NC,NC) 211  
 EP1 [R/9+1,NC,MOS GPIG] SELECT L) 216  
 FE2 [G+1,MOS WR DATA DET#18+10+UJIN,A,B] H,NC,NC) 216  
 FH2 [G+1,MOS WR DATA DET#18+12+UJIN,A,B] H,NC,NC) 215  
 FL1 [G+1,MOS WR DATA DET#18+14+UJIN,A,B] H,NC,NC) 215  
 FR2 [G+1,MOS WR DATA DET#18+16+UJIN,A,B] H,NC,NC) 215

DRN.	DATE	ENG.	DATE	TITLE:
CHK'D.	DATE	BOARD LOCATION:		MOS STORAGE
DATE	DATE	SIZE	CODE	NUMBER
12-19-84	12-19-84	D	CS	M8570-0-SM15
FIRST USED ON OPTION/MODEL: MG20		NEXT HIGHER ASSEMBLY: D-DD-M8570-0		REV. A

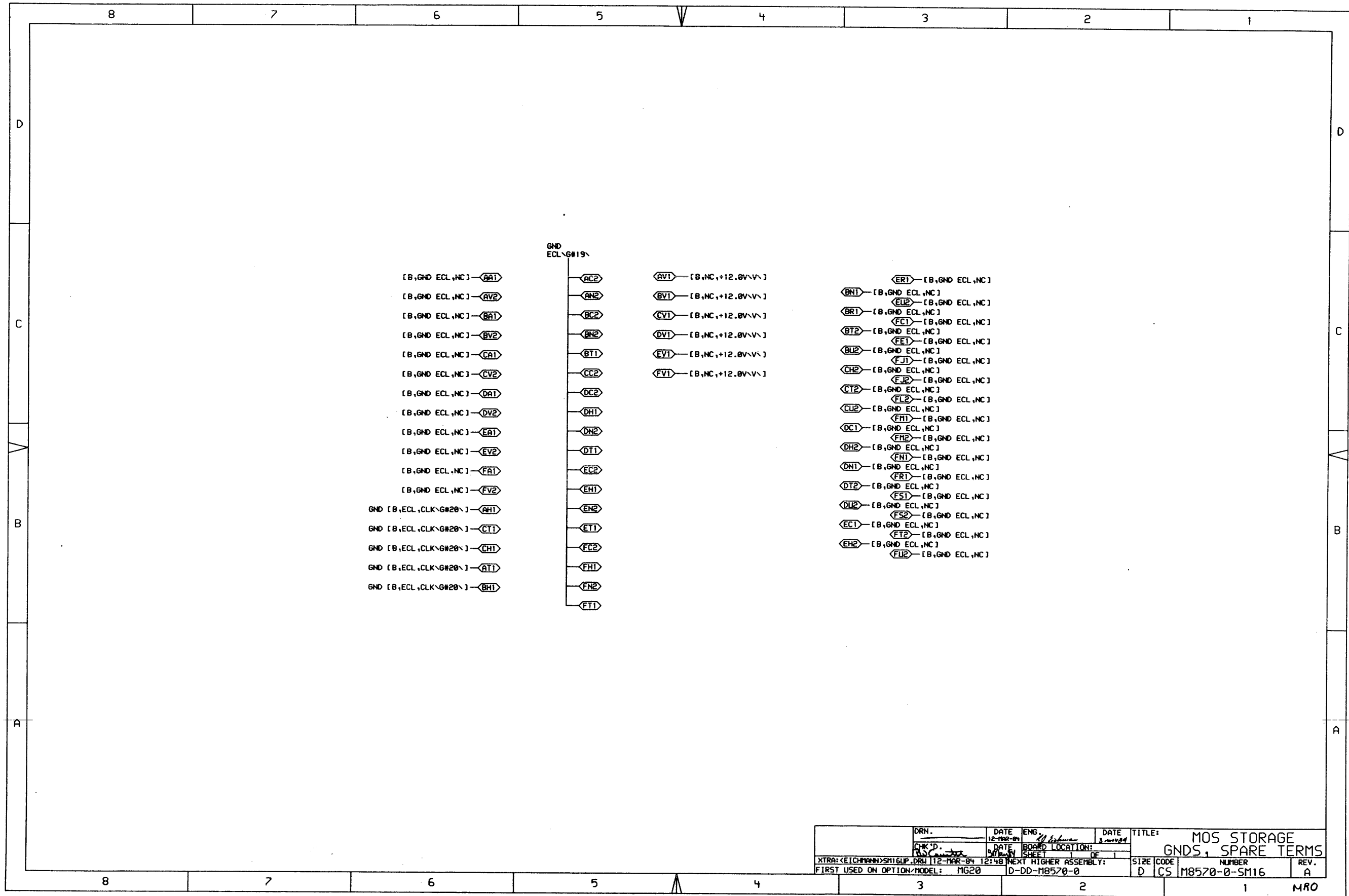

DRN.	DATE	ENG.	DATE	TITLE:
CHK'D.	12-198-84	W. Johnson	3-20-84	MOS STORAGE
DATE	BOARD LOCATION:	DE		GNDS, SPARE TERMS
12-198-84	1	1		
XTRA: <EICHMANN> SM16UP.DRW 12-MAR-84 12:48 NEXT HIGHER ASSEMBLY:				SIZE CODE NUMBER REV.
FIRST USED ON OPTION/MODEL: MG20 D-DD-M8570-0				D CS M8570-0-SM16 A

MRO

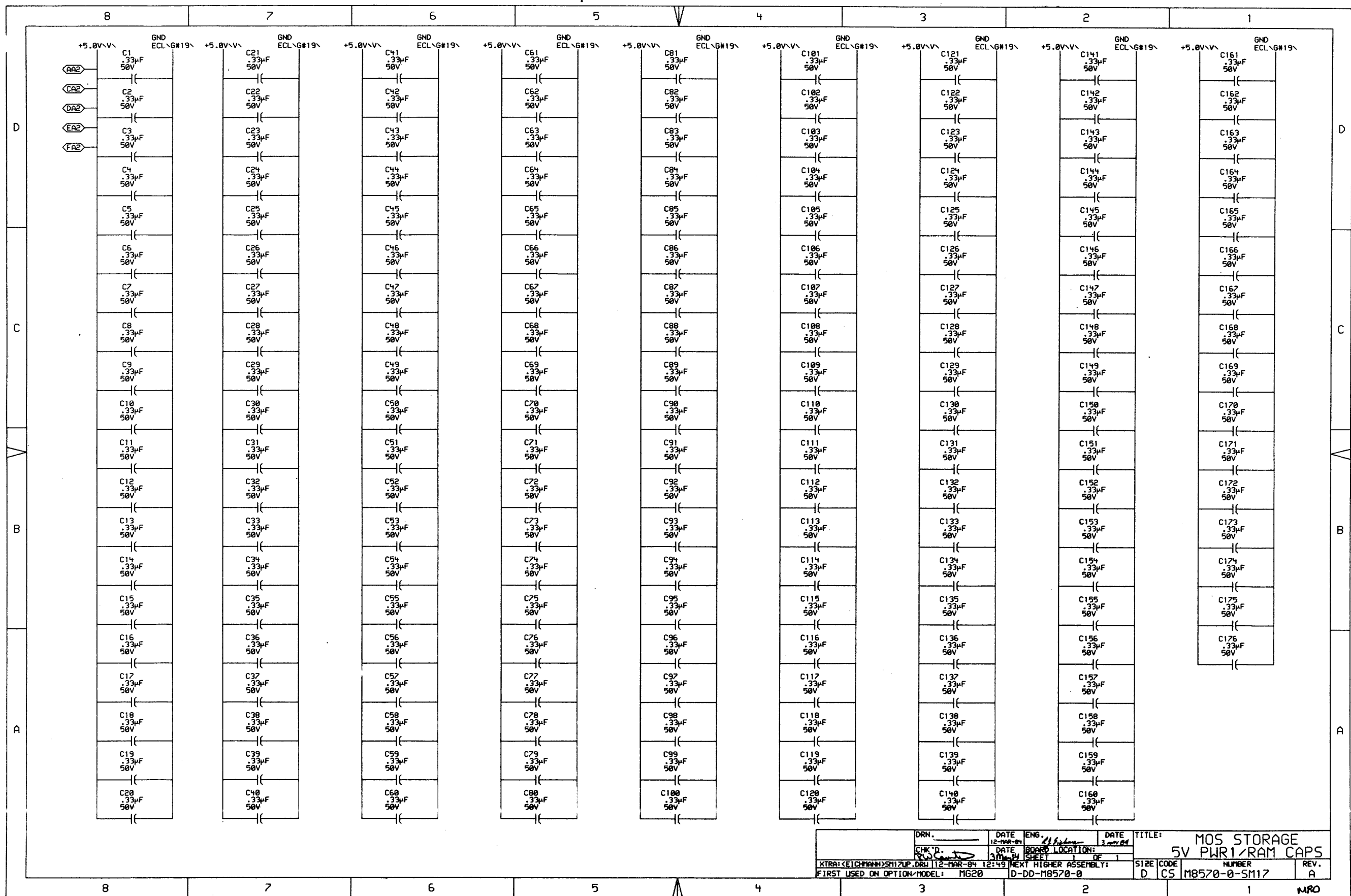

DRN.	DATE	ENG.	DATE	TITLE:
CHK'D.	DATE	BOARD LOCATION:		MOS STORAGE
				5V PWR1/RAM CAPS
FIRST USED ON OPTION/MODEL: MG20				REV. A

MRO

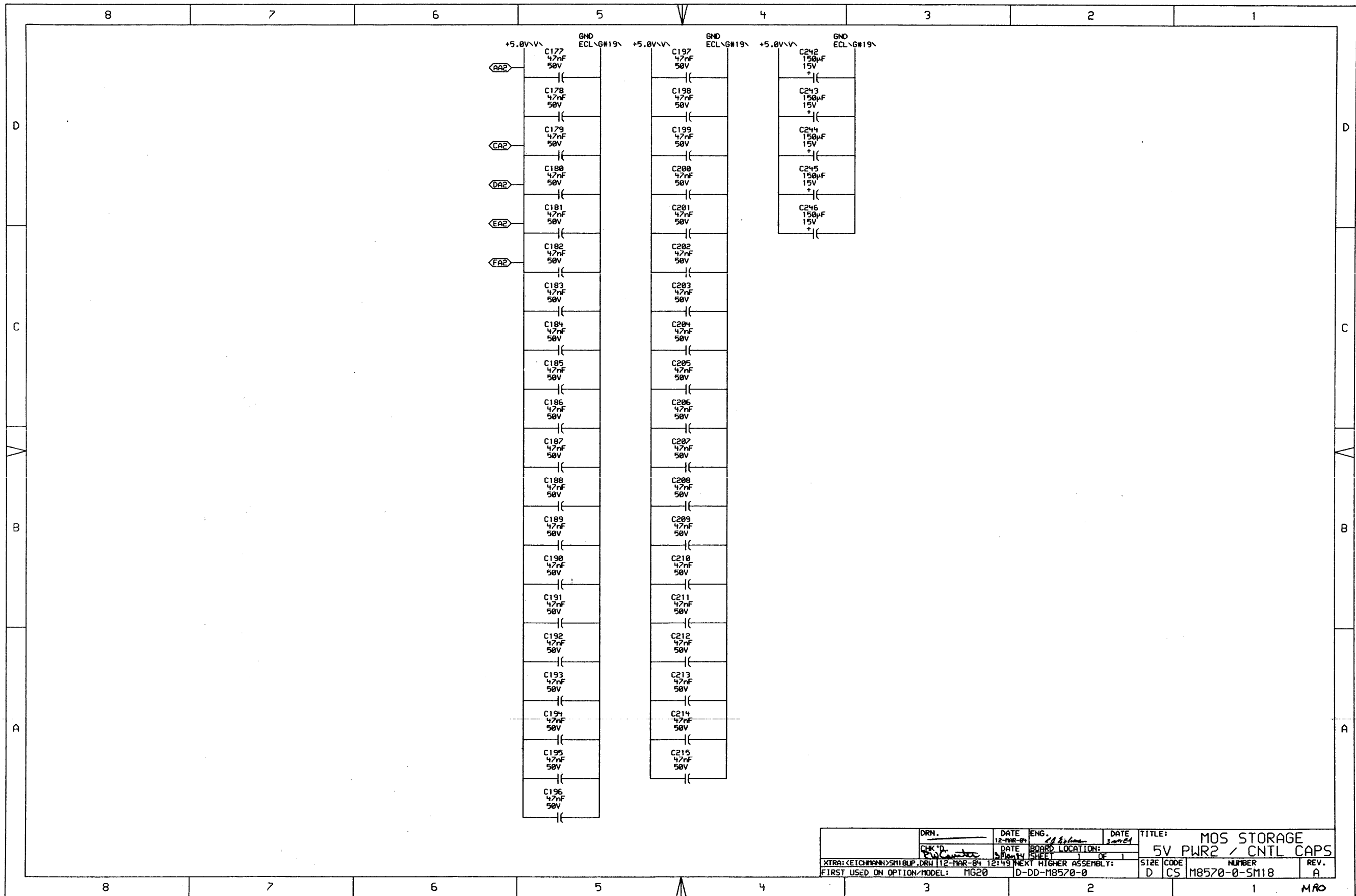

DRN.	DATE	ENG.	DATE	TITLE:
	12-MAR-84	<i>J. E. ...</i>	2-2-84	MOS STORAGE
CHK'D	DATE	BOARD LOCATION:		5V PWR2 / CNTL CAPS
<i>P. ...</i>	DATE	SHEET	OF	
XTRA: (EICHMANN) SM18UP.DRW 12-MAR-84 12:49		NEXT HIGHER ASSEMBLY:		SIZE CODE
FIRST USED ON OPTION/MODEL: MG20		D-DD-M8570-0		NUMBER
				REV.
				A

MAO

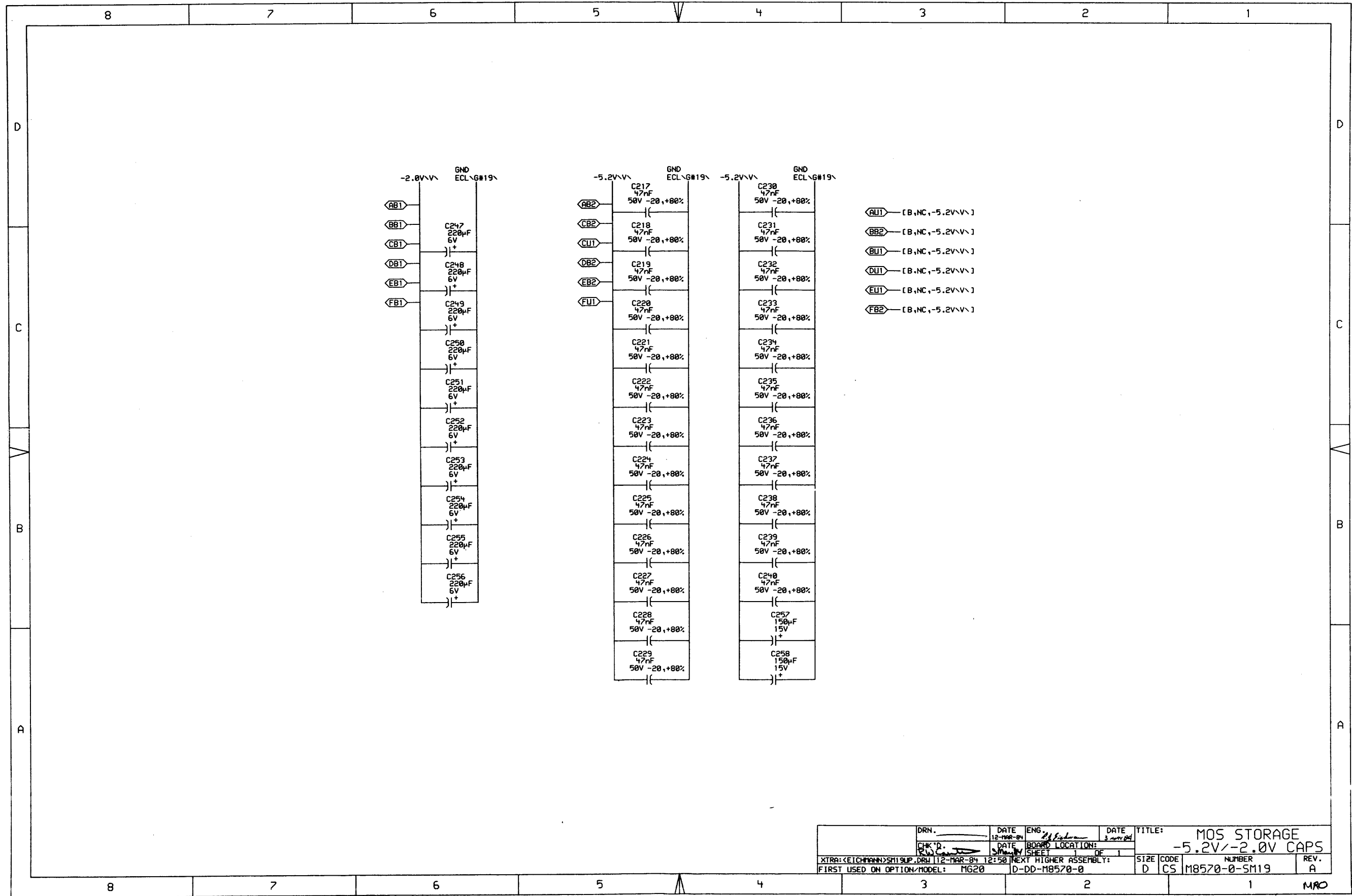

DRN.	DATE	ENG.	DATE	TITLE:
	12-MAR-84	M. K. K.	3-MAR-84	MOS STORAGE
CHK'D.	DATE	BOARD LOCATION:		-5.2V/-2.0V CAPS
R. W. C.	3-MAR-84	SHEET	OF	
XTRA: (EICHMANN) SM19UP, DRN 12-MAR-84 12:50 NEXT HIGHER ASSEMBLY:				SIZE CODE NUMBER REV.
FIRST USED ON OPTION/MODEL: MG20 D-DD-M8570-0				D CS M8570-0-SM19 A

MRO

DRAWING NUMBER	PAGE	PART NO.	DESCRIPTION	REVISIONS
			ECO NUMBER	- 1
		M8580-00	MODULE REVISION	A A1
D-LA-M8580-0-0	4		DUAL TRANSLATOR	A A
K-PL-M8580-0-DBP	2		PARTS LIST, M8580	A B
D-CS-M8580-0-DT01	1		DUAL TRANSLATOR	- -
D-CS-M8580-0-DT02	1		DATA TRNCVR 0-5	- -
D-CS-M8580-0-DT03	1		DATA TRNCVR 6-11	- -
D-CS-M8580-0-DT04	1		DATA TRNCVR 12-17	- -
D-CS-M8580-0-DT05	1		ADDRESS DRIVERS	- -
D-CS-M8580-0-DT06	1		CTRL & REF VOLT	- A
D-CS-M8580-0-DT07	1		MEM DATA DRVRS	- -
D-CS-M8580-0-DT08	1		POWER. GND. CAPS.	- -
D-CS-M8580-0-RES	1		TERMINATORS	- -
K-PC-M9580-0-DBC	-		CALDEC DESIGN DATA BASE	A A
D-DD-5012771-0	1		DRAWING DIRECTORY, 5012771	REF REF
P00-M8580-00	-		PROCESS SHEET (REF ONLY)	- -

D  
C  
B  
A

D  
C  
B  
A

REV. A  
NUMBER M8580-0  
SIZE CODE DD

THIS DRAWING AND SPECIFICATIONS ARE THE PROPERTY OF DIGITAL EQUIPMENT CORPORATION AND SHALL NOT BE REPRODUCED OR COPIED OR USED IN WHOLE OR IN PART AS THE BASIS FOR THE MANUFACTURE OR SALE OF ITEMS WITHOUT WRITTEN PERMISSION. COPYRIGHT © 1984 DIGITAL EQUIPMENT CORPORATION

REVISIONS	
CHK	CHANGE NO. REV

**digital** DRN. D. DELLORCO DATE 09-NOV-84 ENG. DATE 09-NOV-84 TITLE: DRAWING DIRECTORY M8580

CHK'D. DATE BOARD LOCATION: N/A

DSK: M8580A.T2P(4,36) 09-NOV-84 16:06 SHEET 1 OF 1

FIRST USED ON OPTION/MODEL: N/A N/A NEXT HIGHER ASSEMBLY:

SIZE CODE D DD NUMBER M8580-0 REV. A

THIS DRAWING AND APPROPRIATE DIMENSIONS ARE THE PROPERTY OF AEGION ELECTRONIC CORPORATION AND SHALL NOT BE REPRODUCED OR COPIED IN WHOLE OR IN PART WITHOUT THE WRITTEN PERMISSION IN FULL OF THE AEGION ELECTRONIC CORPORATION.

SPARES

38 (REV 12)

37

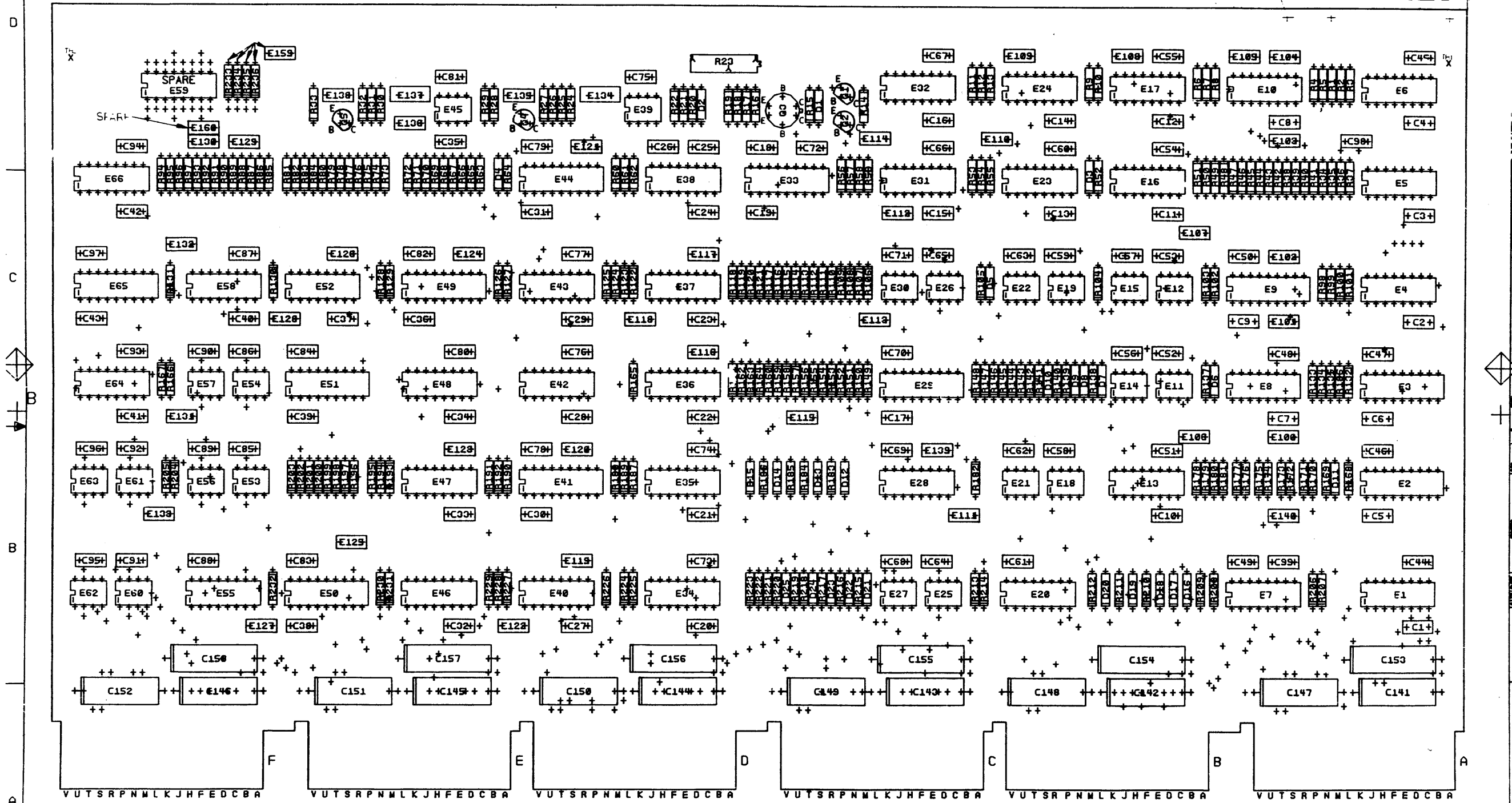

NOTES: 1. FOR POWER & GND PINS REFER TO: D-CS-M8580-0-DT08

CHANGE NO	REV

ETCH REV.	B
P.C. DESIGN DATA BASE REV.	A

SIGNATURES		DATE	digital
DRM.	<i>[Signature]</i>	6-1-78	
CHK'D.	<i>[Signature]</i>	6-1-78	TITLE
ENG.	<i>[Signature]</i>	6-1-78	DUAL TRANSLATOR
PROD. ENG.	<i>[Signature]</i>	6-1-78	
SCALE	2/1		SIZE CODE
SHT.	1 OF 4		NUMBER
NEXT HIGHER ASSY. D-DD-M8580-0			REV
			A

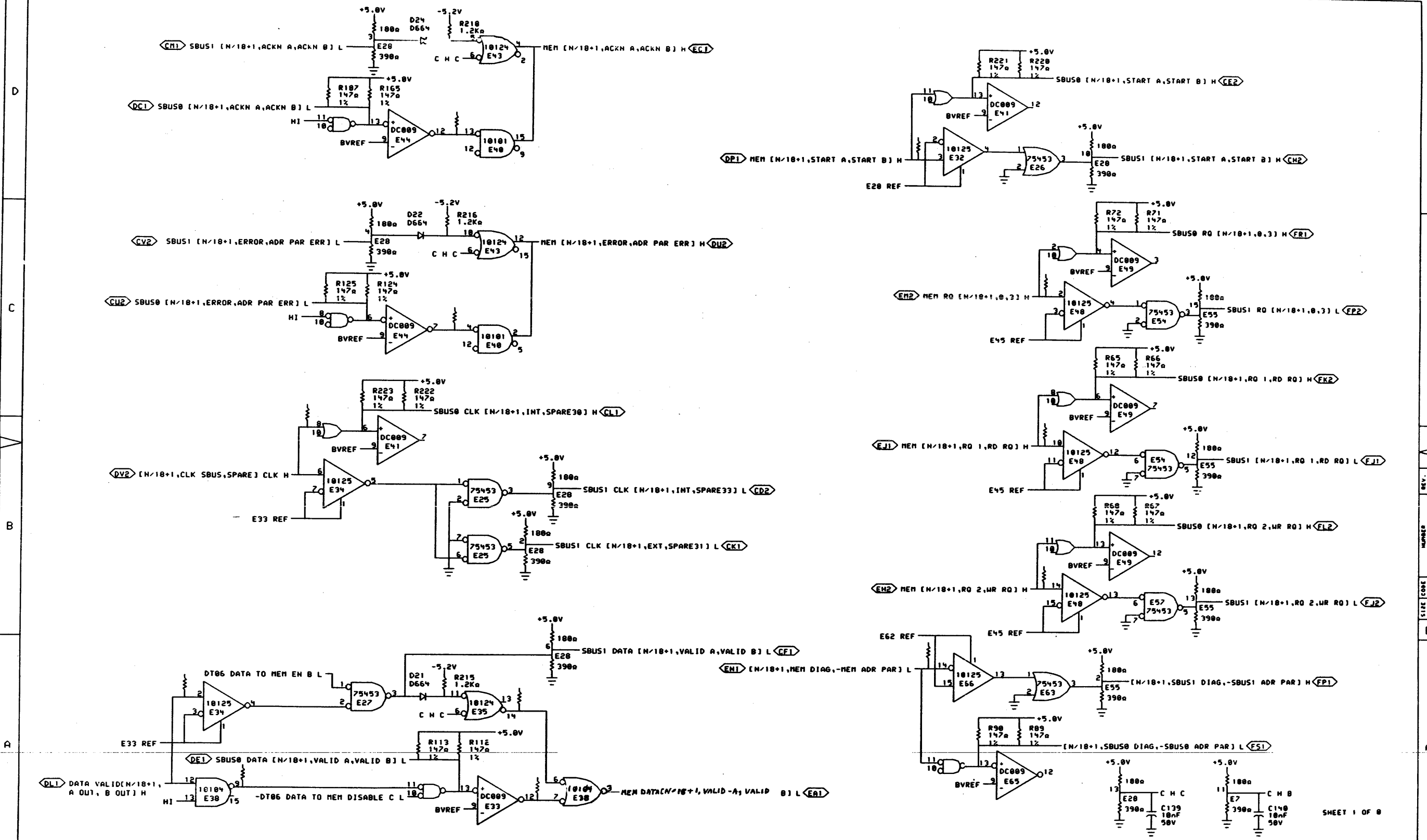

THIS DRAWING AND SPECIFICATIONS HEREIN, ARE THE PROPERTY OF DIGITAL EQUIPMENT CORPORATION AND SHALL NOT BE REPRODUCED OR COPIED OR USED IN WHOLE OR IN PART AS THE BASIS FOR THE MANUFACTURE OR SALE OF ITEMS WITHOUT WRITTEN PERMISSION. COPYRIGHT © 1970, DIGITAL EQUIPMENT CORPORATION.

REVISIONS	CHK	CHANGE NO.	REV

DRN. <i>C. Smith</i>	DATE 10-JUL-70	ENG. <i>L. J. ...</i>	DATE 10-JUL-70	TITLE: DUAL TRANSLATOR
CHK. <i>C. Smith</i>	DATE 10-JUL-70	BOARD LOCATION: 1010-0-00504	SHEET 1 OF 1	SIZE CODE D CS
PUB. (M8500-N05) DT01EP.DRW	10-JUL-70 11:35	NEXT HIGHER ASSEMBLY:	FIRST USED ON OPTION/MODEL: MF20	NUMBER M8500-0-DT01

REV. 1	REV. 1	REV. 1	REV. 1	REV. 1
--------	--------	--------	--------	--------

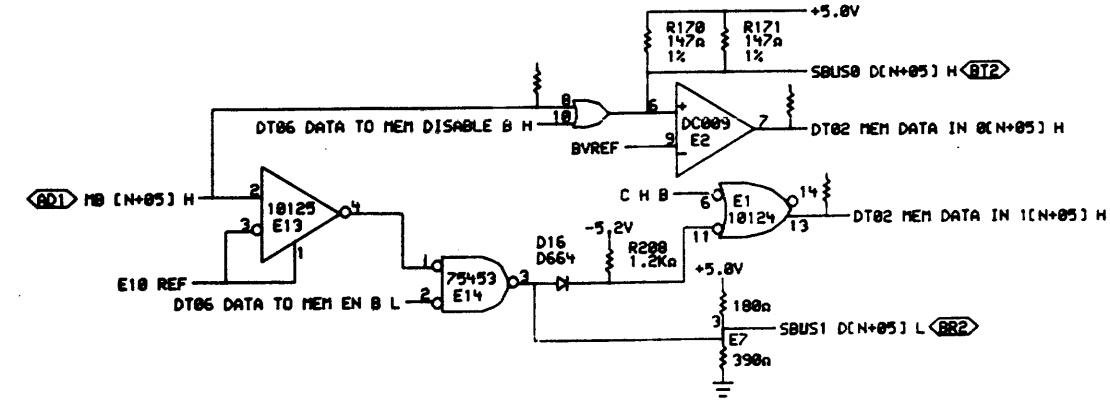
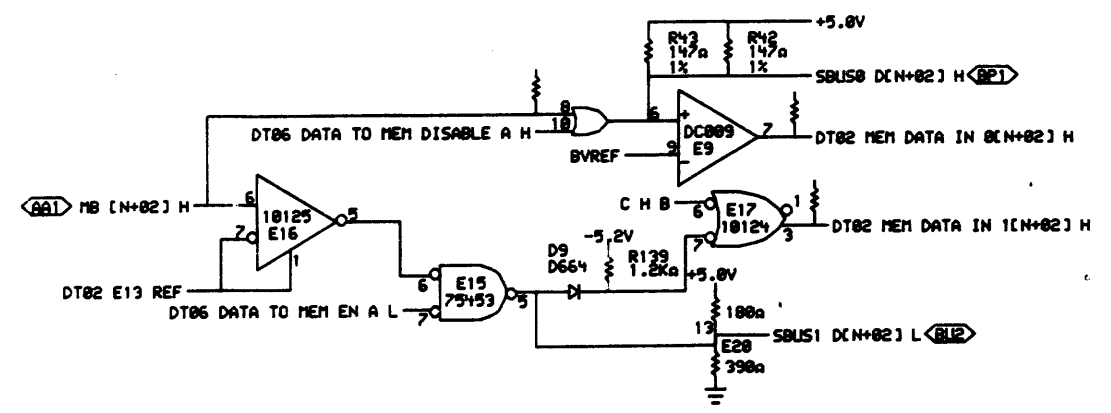
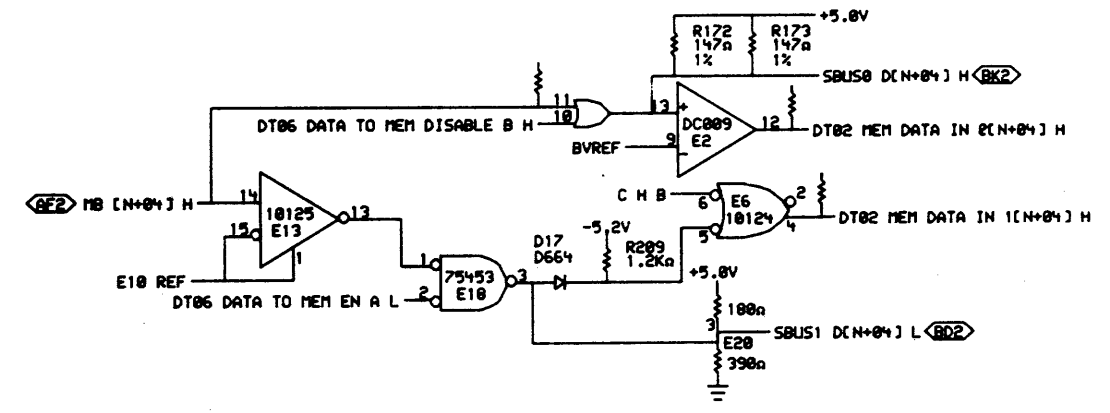
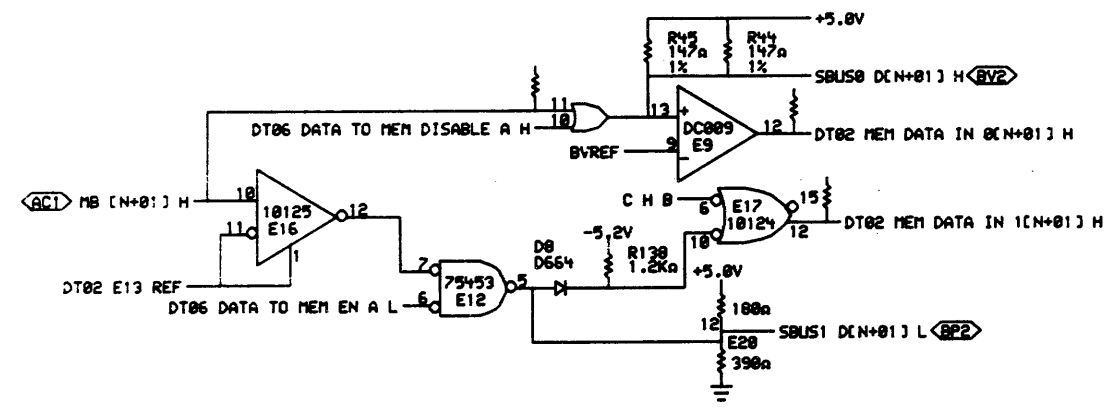
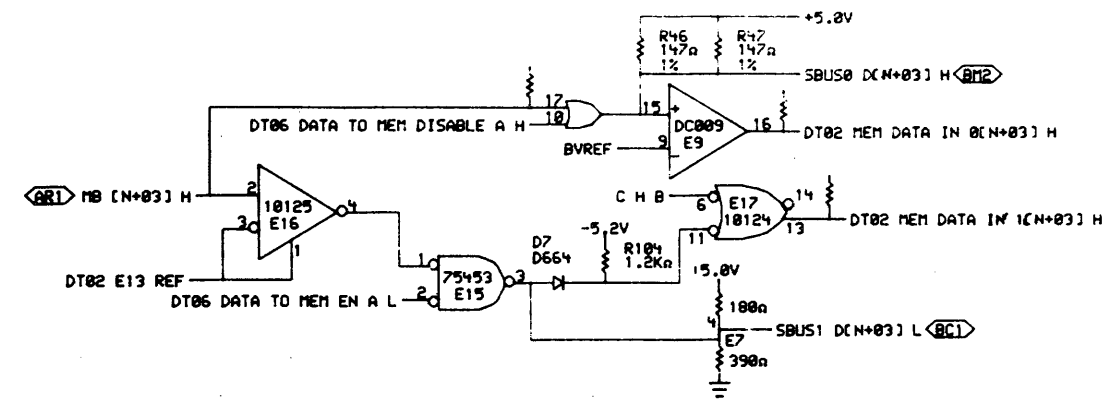
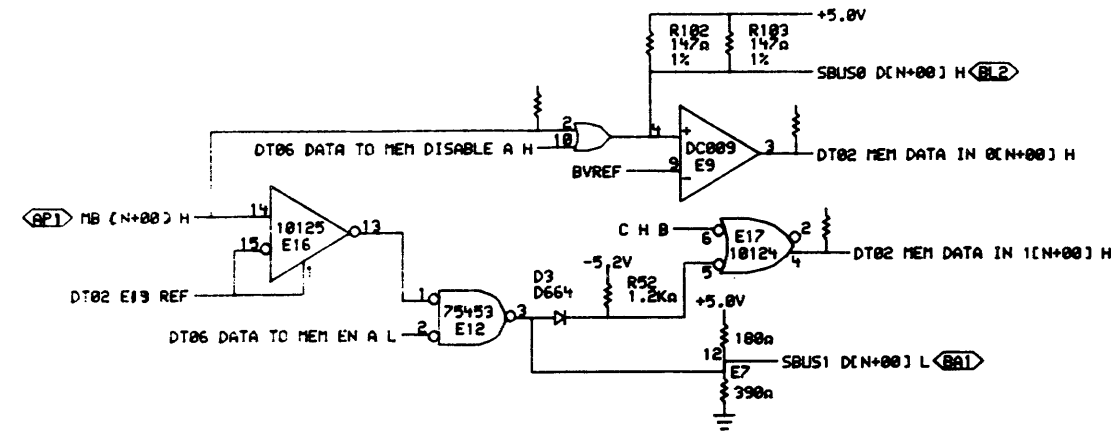

SHEET 2 OF 8

THIS DRAWING AND SPECIFICATIONS HEREIN ARE THE PROPERTY OF DIGITAL EQUIPMENT CORPORATION AND SHALL NOT BE REPRODUCED OR COPIED OR USED IN WHOLE OR IN PART AS THE BASIS FOR THE MANUFACTURE OR SALE OF ITEMS WITHOUT WRITTEN PERMISSION. COPYRIGHT © 1979, DIGITAL EQUIPMENT CORPORATION.

CHK	CHANGE NO.	REV

REV	DESCRIPTION	DATE	BY

	DRN. <i>Smith</i>	DATE <i>11-28-78</i>	ENG. <i>D.J. Chin</i>	DATE <i>2-18-78</i>	TITLE: <b>DUAL TRANSLATOR DATA TRNCVR 0-5</b>
	DATE <i>11-28-78</i> DRAWN BY <i>Smith</i> CHECKED BY <i>Smith</i> FIRST USED ON OPTION/MODEL: <i>MF20</i>	BOARD LOCATION: <i> </i> SHEET: <i> </i> OF <i> </i> NEXT HIGHER ASSEMBLY: <i> </i>	SIZE CODE: <i>D</i> CS: <i>CS</i>	NUMBER: <i> </i> REV.: <i> </i>	

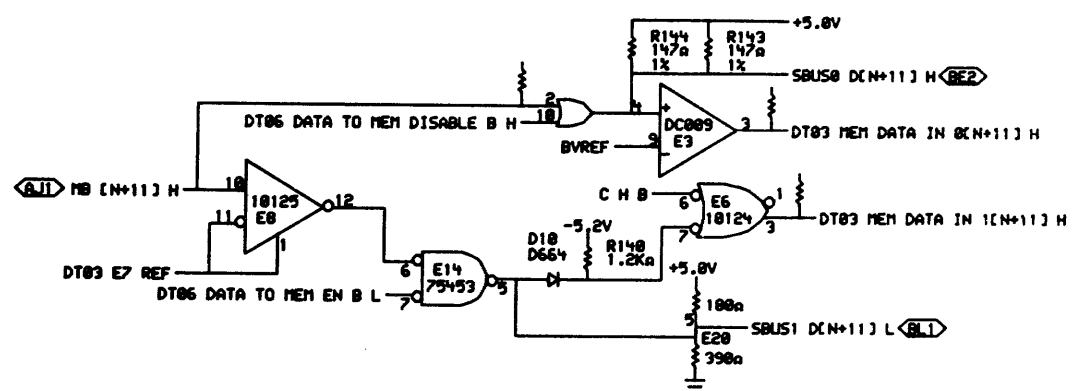
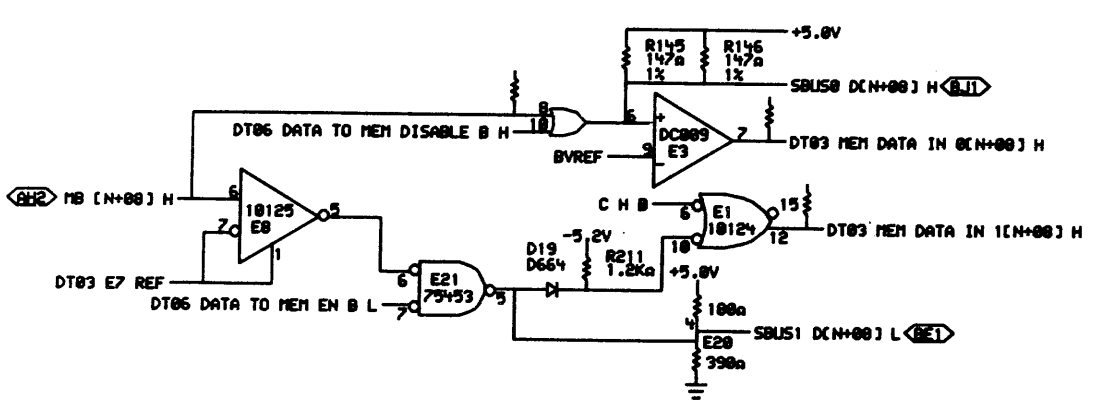
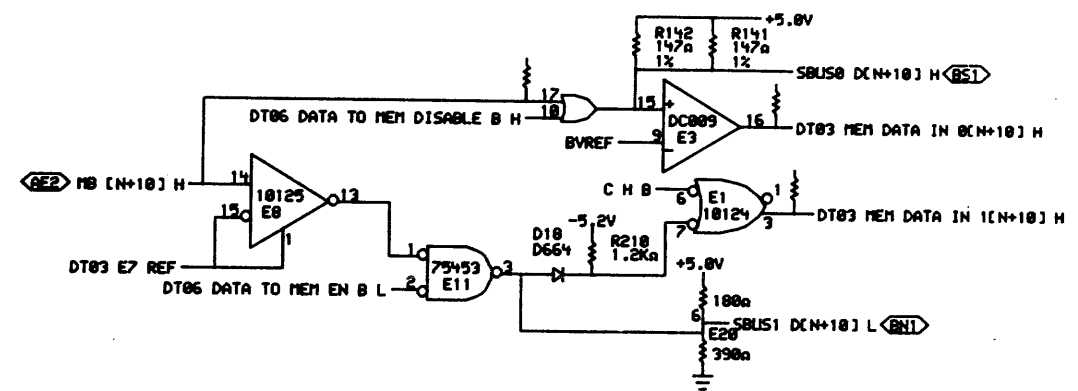
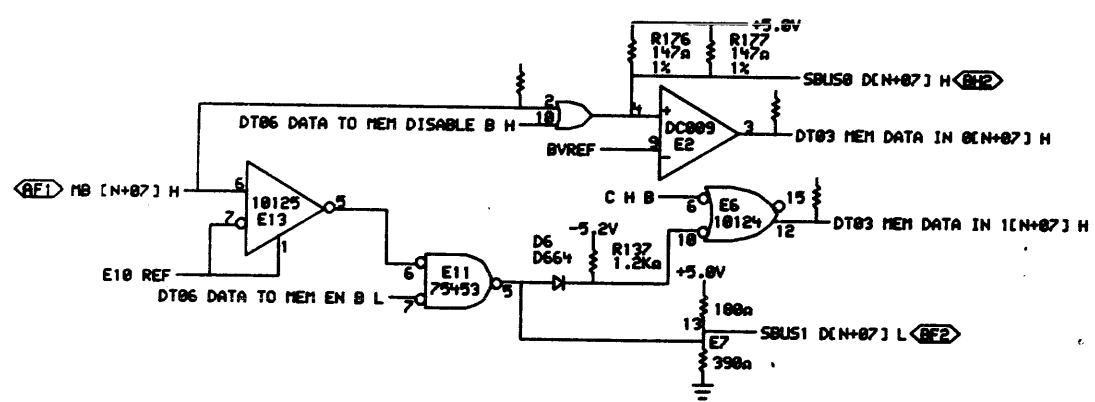
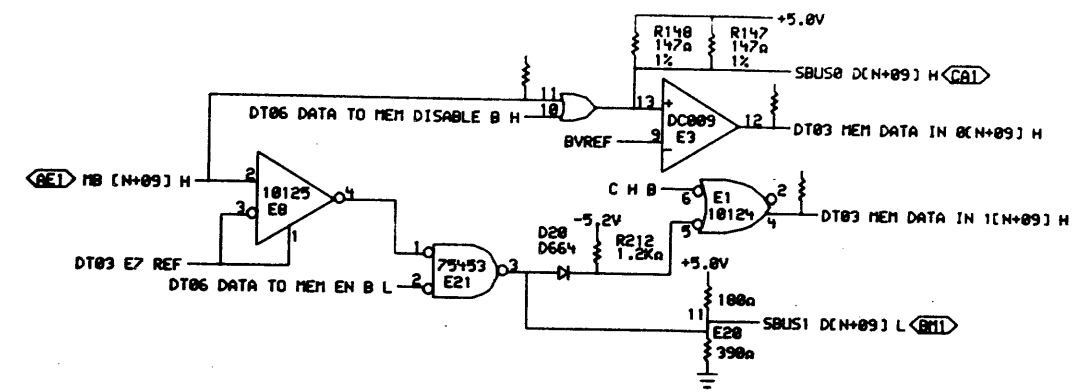
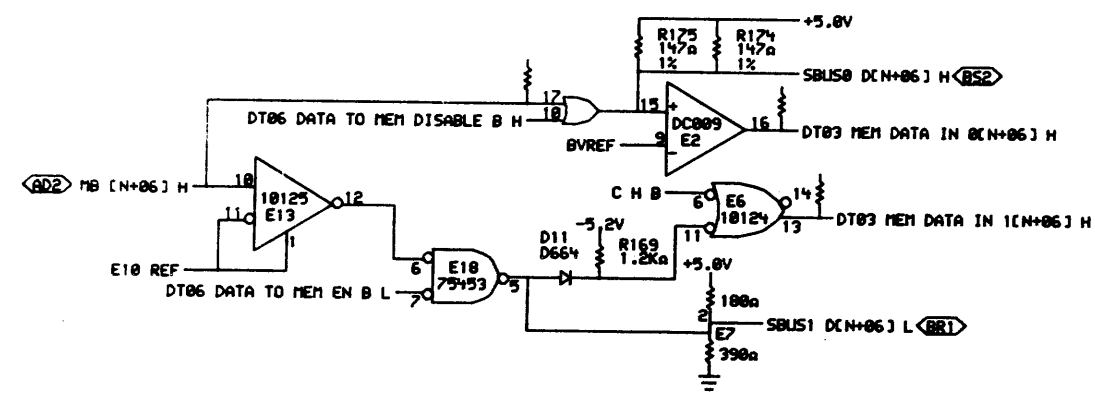

SHEET 3 OF 8

REVISIONS	
CHK	CHANGE NO. REV

--	--	--	--	--	--	--	--	--	--

	DRN: <i>C. Smith</i>	DATE: 10-18-78	ENG: <i>D.J. Chin</i>	DATE: 2-18-78	TITLE: DUAL TRANSLATOR DATA TRNCVR 6-11
	CHK: <i>P. Lucis</i>	DATE: 10-18-78	BOARD LOCATION:		
FIRST USED ON OPTION/MODEL: MF20		NEXT HYPER ASSEMBLY: D-DD-M8580-0		SIZE: D	CODE: CS
				NUMBER: M8580-0-DT03	REV:

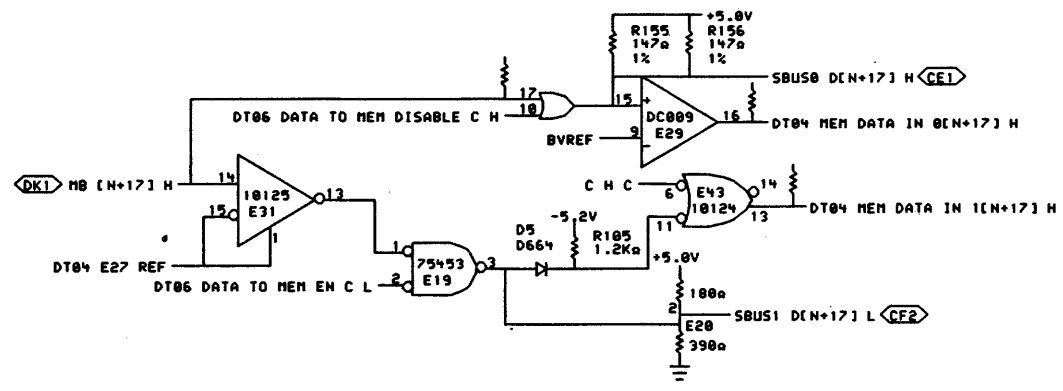
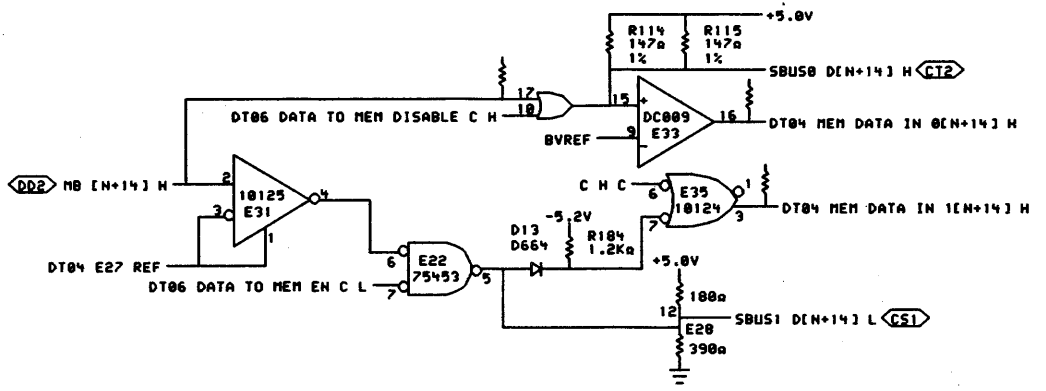
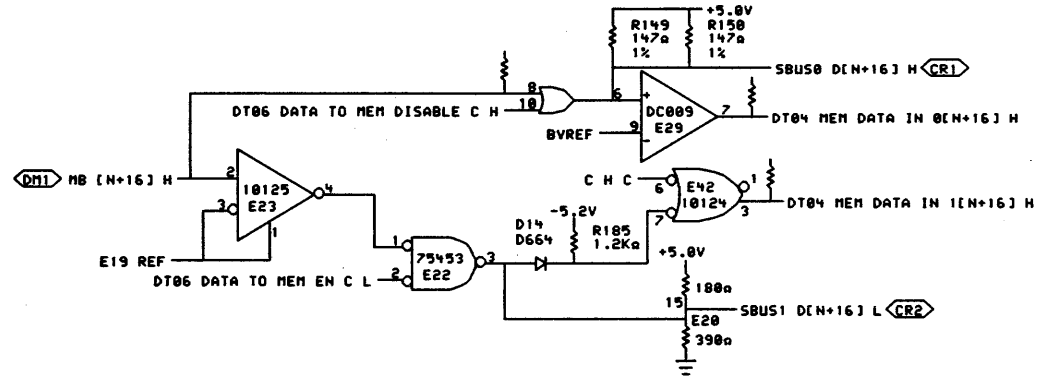
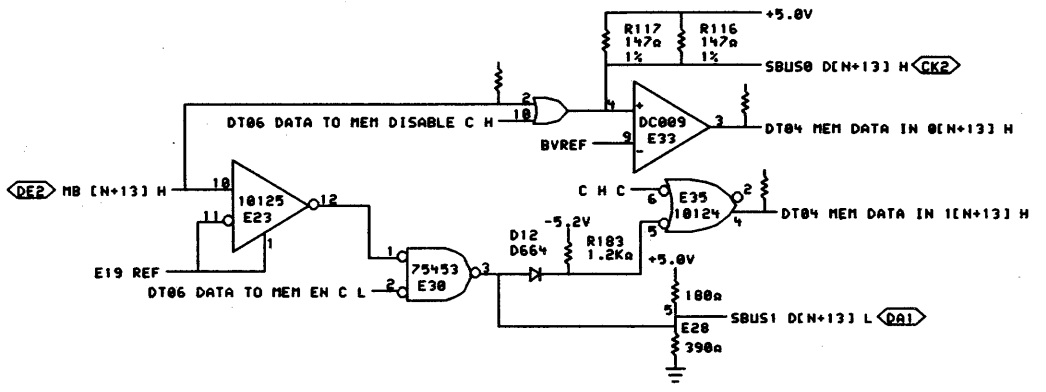
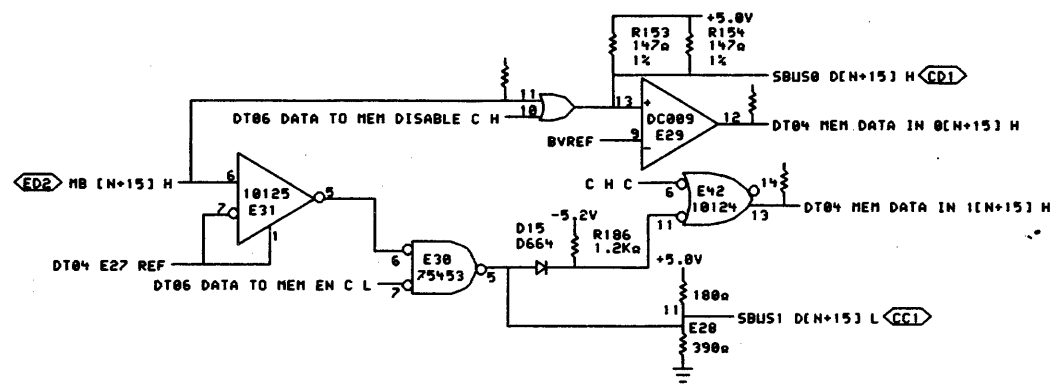
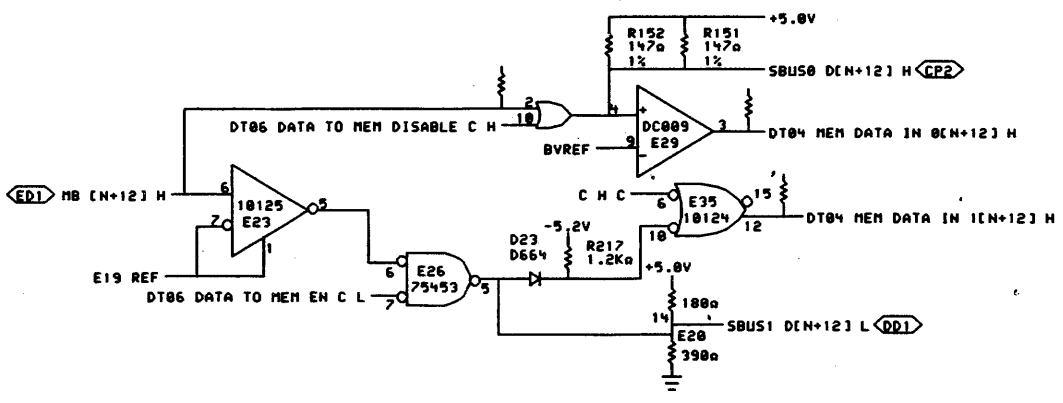

SHEET 4 OF 8

THIS DRAWING AND SPECIFICATIONS, HEREIN, ARE THE PROPERTY OF DIGITAL EQUIPMENT CORPORATION AND SHALL NOT BE REPRODUCED OR COPIED IN WHOLE OR IN PART AS THE BASIS FOR THE MANUFACTURE OR SALE OF ITEMS WITHOUT WRITTEN PERMISSION. COPYRIGHT © 1976, DIGITAL EQUIPMENT CORPORATION.

REVISIONS	
CHK	CHANGE NO. REV

--	--	--	--	--	--	--	--	--	--

digital	DRN. <i>P. Smith</i>	DATE 18-JUL-78	ENGR. <i>R. K. ...</i>	DATE 17-JUL-78	TITLE: DUAL TRANSLATOR DATA TRNCVR 12-17
	CHK. <i>P. ...</i>	DATE 18-JUL-78	BOARD LOCATION: 1 OF 1	SHEET 4 OF 8	
FIRST USED ON OPTION/MODEL: MF20		NEXT HIGHER ASSEMBLY: D-DD-M8580-0		SIZE CODE D CS	NUMBER M8580-0-DT04

REV. 1 2 3 4 5 6 7 8 9 10 11 12 13 14 15 16 17 18 19 20 21 22 23 24 25 26 27 28 29 30 31 32 33 34 35 36 37 38 39 40 41 42 43 44 45 46 47 48 49 50 51 52 53 54 55 56 57 58 59 60 61 62 63 64 65 66 67 68 69 70 71 72 73 74 75 76 77 78 79 80 81 82 83 84 85 86 87 88 89 90 91 92 93 94 95 96 97 98 99 100

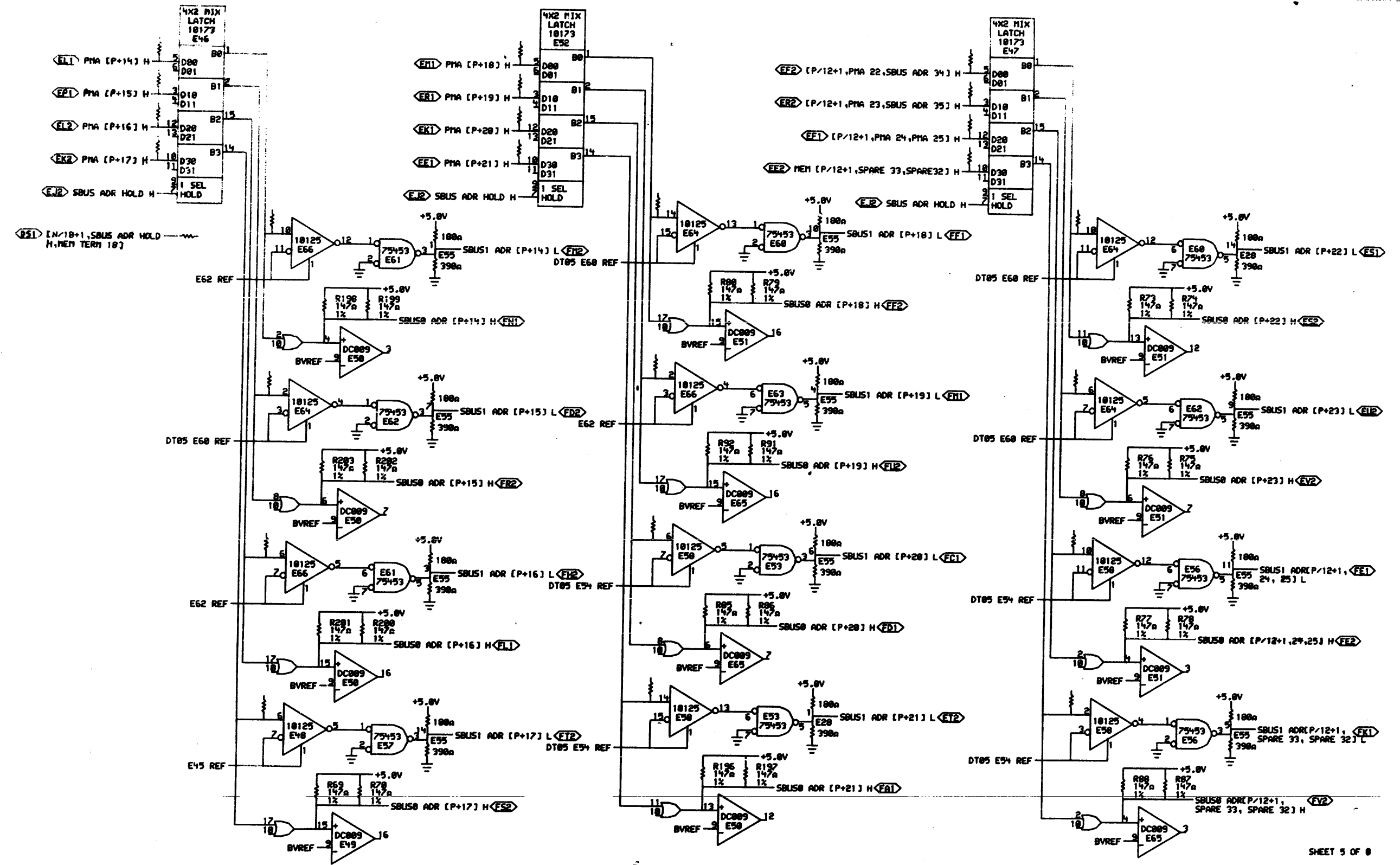

SHEET 5 OF 8

THIS DRAWING AND SPECIFICATIONS HEREIN, ARE THE PROPERTY OF DIGITAL EQUIPMENT CORPORATION AND SHALL NOT BE REPRODUCED OR COPIED OR USED IN WHOLE OR IN PART AS THE BASIS FOR THE MANUFACTURE OR SALE OF ITEMS WITHOUT WRITTEN PERMISSION. COPYRIGHT © 1974, DIGITAL EQUIPMENT CORPORATION.

REVISIONS	
CHK	CHANGE NO. REV

DRN. <i>P. Smith</i>	DATE <i>11-28-70</i>	ENG. <i>J. Chin</i>	DATE <i>7-18-70</i>	TITLE: <b>DUAL TRANSLATOR ADDRESS DRIVERS</b>
CHK. <i>P. Smith</i>	DATE <i>11-28-70</i>	DATE <i>7-18-70</i>	BOARD LOCATION: <i>1</i>	SIZE CODE: <i>D</i>
FIRST USED ON OPTION/MODEL: <i>MF20</i>			DATE NEXT HIGHER ASSEMBLY: <i>D-DD-M8580-0</i>	NUMBER: <i>CS M8580-0-DT05</i>

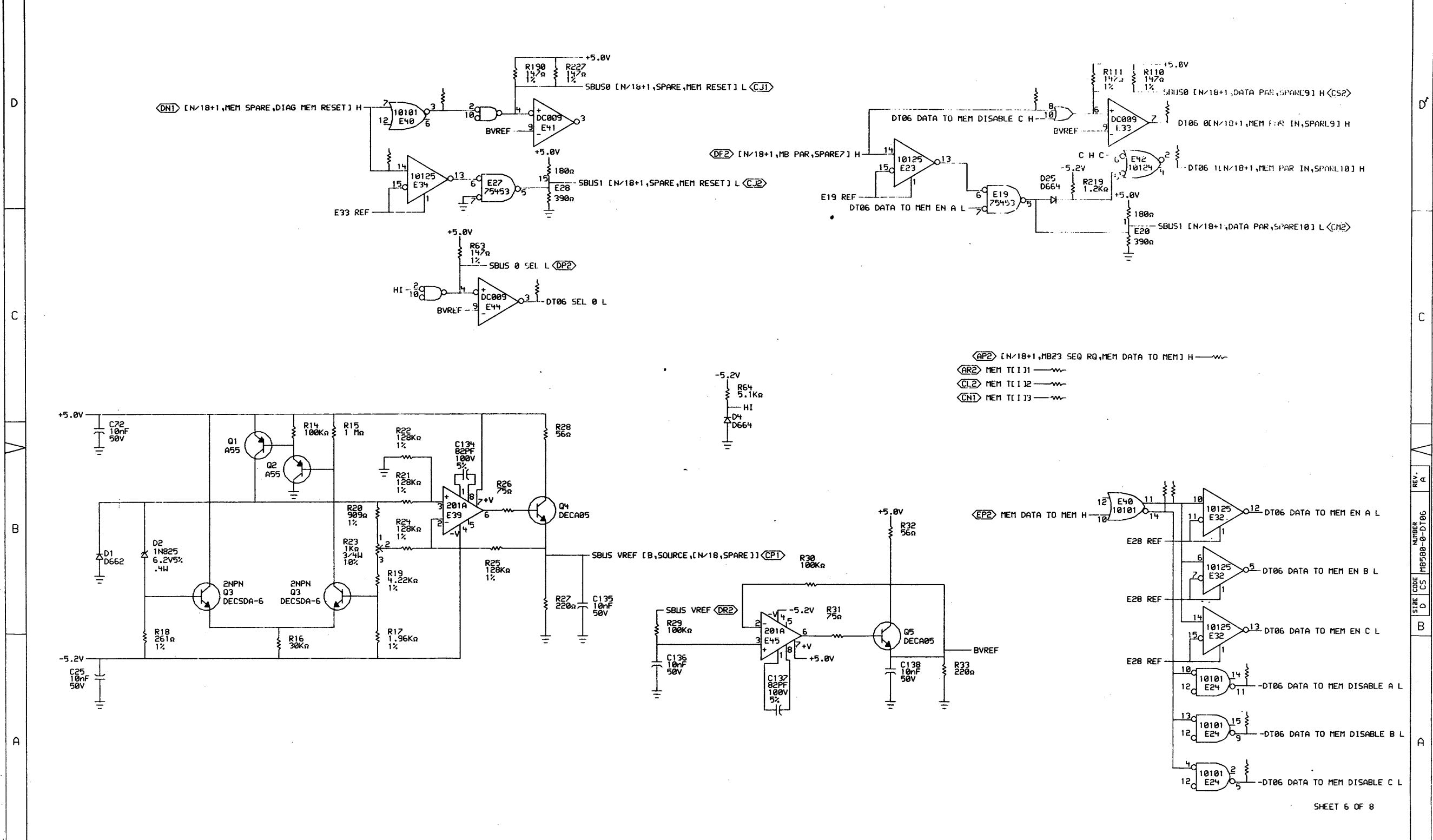

- AP2 [N/18+1, MB23 SEQ RQ, MEM DATA TO MEM] H
- AR2 MEM TI I J1
- CL2 MEM TI I J2
- CI2 MEM TI I J3

REVISIONS	
CHK	CHANGE NO. REV.

digital

DR: J. J. J. DATE: 08-NOV-84 ENG: DATE: 29-NOV-84 TITLE: DUAL TRANSLATOR CTRL & REF VOLT

CHK: D DATE: 12-NOV-84 BOARD LOCATION: 1

SUCOR: (BORN SCRATCH) DT06 REF. DMI 08-NOV-84 09:40 NEXT HIGHER ASSEMBLY: 1

FIRST USED ON OPTION/MODEL: MF20 D-DD-M8580-0

SIZE CODE NUMBER REV: D CS M8580-0-DT06 A

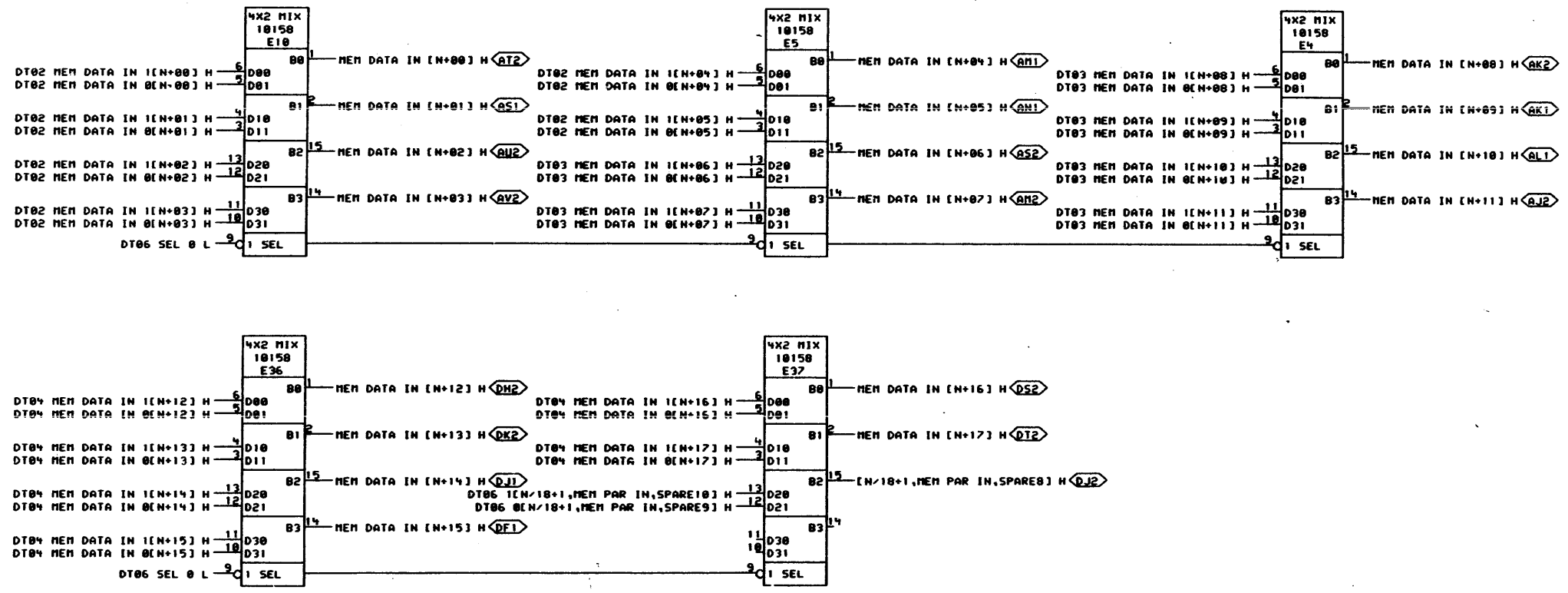

SHEET 7 OF 8

THIS DRAWING AND SPECIFICATIONS, HEREIN, ARE THE PROPERTY OF DIGITAL EQUIPMENT CORPORATION AND SHALL NOT BE REPRODUCED OR COPIED OR USED IN WHOLE OR IN PART AS THE BASIS FOR THE MANUFACTURE OR SALE OF ITEMS WITHOUT WRITTEN PERMISSION. COPYRIGHT © 1979, DIGITAL EQUIPMENT CORPORATION.

REVISIONS		
CHK	CHANGE NO.	REV

**digital**  
DRN. *C. Smith*  
CHK. *J. J. J.*

DATE 06-20-78  
ENG. *D. Chen*  
DATE 08-10-78  
BOARD LOCATION: 1 OF 1  
SHEET 1 OF 1  
NEXT HIGHER ASSEMBLY: D-DD-M8580-0  
FIRST USED ON OPTION/MODEL: MF20

TITLE: **BUS SELECT MEM DATA DRVRS**  
SIZE CODE: **0 CS**  
NUMBER: **M8580-0-DT07**  
REV.:

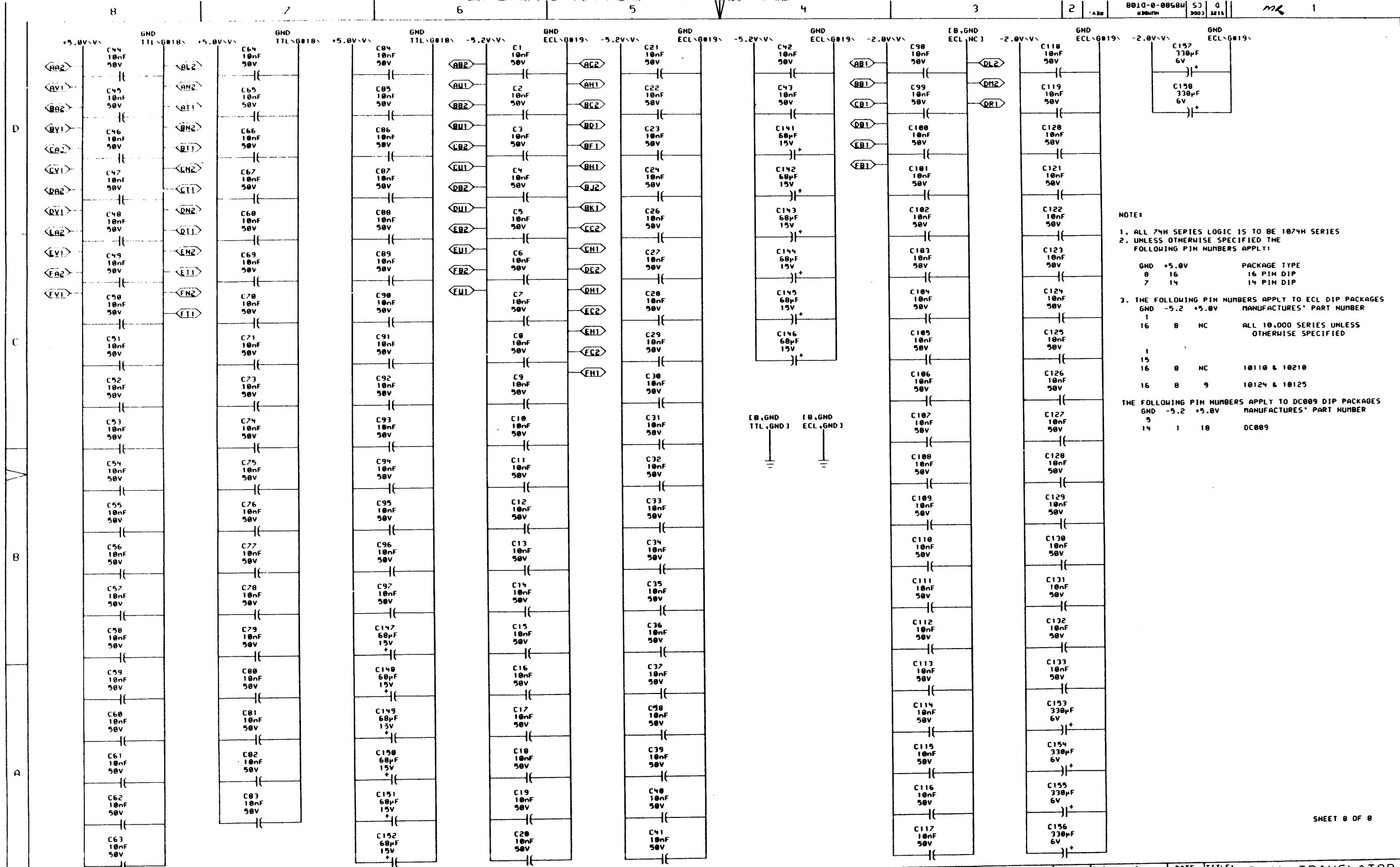

NOTE:  
 1. ALL 74H SERIES LOGIC IS TO BE 1074H SERIES  
 2. UNLESS OTHERWISE SPECIFIED THE FOLLOWING PIN NUMBERS APPLY:  
 GND +5.0V PACKAGE TYPE  
 8 16 16 PIN DIP  
 7 14 14 PIN DIP  
 3. THE FOLLOWING PIN NUMBERS APPLY TO ECL DIP PACKAGES  
 GND -5.2 +5.0V MANUFACTURES' PART NUMBER  
 1 8 NC ALL 10,000 SERIES UNLESS OTHERWISE SPECIFIED  
 15 8 NC 10110 & 10210  
 16 8 9 10124 & 10125  
 THE FOLLOWING PIN NUMBERS APPLY TO DC009 DIP PACKAGES  
 GND -5.2 +5.0V MANUFACTURES' PART NUMBER  
 5 14 1 18 DC009

SHEET 8 OF 8

THIS DRAWING AND SPECIFICATIONS, HEREIN, ARE THE PROPERTY OF DIGITAL EQUIPMENT CORPORATION AND SHALL NOT BE REPRODUCED OR COPIED OR USED IN WHOLE OR IN PART AS THE BASIS FOR THE MANUFACTURE OR SALE OF ITEMS WITHOUT WRITTEN PERMISSION. COPYRIGHT © 1974, DIGITAL EQUIPMENT CORPORATION.

CHK	CHANGE NO.	REV.

**digital** ORN *P. Lucas* DATE *06-JUN-78* ENG. *D. Allen* DATE *04-JUN-78*  
 CHK *P. Lucas* DATE *02-JUN-78* BOARD LOCATION: *2 of 7* SHEET *1* OF *1*  
 DT08EF.DRW 4.622 103-JUN-78 16:53 NEXT HIGHER ASSEMBLY: *D-DD-M8580-0*  
 FIRST USED ON OPTION/MODEL: *MF20*

TITLE: **DUAL TRANSLATOR POWER, GND, CAPS.**  
 SIZE CODE **D CS** NUMBER **M8580-0-DT08** REV.

REV. NUMBER  
 CS M8580-0-DT08  
 B  
 A

RESISTOR LOC(PIN)	SHOWN ON DRW#	REF	VALUE	TERMINATES SIGNAL
R61(1)	DT01	A6	68Ω	%E33(12)
R62(1)	DT01	A6	68Ω	%E35(14)
R109(1)	DT01	A7	68Ω	%E30(9)
R58(1)	DT06	B2	68Ω	%E40(11)
R13(1)	DT06	B2	68Ω	%E40(14)
R188(1)	DT06	D6	68Ω	%E40(3)
R228(1)	DT01	D6	68Ω	%E44(12)
R224(1)	DT01	C6	68Ω	%E44(7)
R97(1)	DT05	C7	68Ω	%E46(1)
R128(1)	DT05	A7	68Ω	%E46(14)
R94(1)	DT05	B7	68Ω	%E46(15)
R205(1)	DT05	C7	68Ω	%E46(2)
R167(1)	DT05	C2	68Ω	%E47(1)
R131(1)	DT05	A2	68Ω	%E47(14)
R130(1)	DT05	B2	68Ω	%E47(15)
R204(1)	DT05	C2	68Ω	%E47(2)
R166(1)	DT05	C5	68Ω	%E52(1)
R232(1)	DT05	A5	68Ω	%E52(14)
R93(1)	DT05	B5	68Ω	%E52(15)
R95(1)	DT05	C5	68Ω	%E52(2)
R60(1)	DT01	A8	68Ω	DATA VALID(N/18+1, A OUT, B OUT) H
R49(1)	DT02	D5	68Ω	DT02 MEM DATA IN 0(N+00) H
R51(1)	DT02	C5	68Ω	DT02 MEM DATA IN 0(N+01) H
R8(1)	DT02	B5	68Ω	DT02 MEM DATA IN 0(N+02) H
R6(1)	DT02	D2	68Ω	DT02 MEM DATA IN 0(N+03) H
R39(1)	DT02	C2	68Ω	DT02 MEM DATA IN 0(N+04) H
R41(1)	DT02	B2	68Ω	DT02 MEM DATA IN 0(N+05) H
R48(1)	DT02	C5	68Ω	DT02 MEM DATA IN 1(N+00) H
R50(1)	DT02	B5	68Ω	DT02 MEM DATA IN 1(N+01) H
R10(1)	DT02	A5	68Ω	DT02 MEM DATA IN 1(N+02) H
R7(1)	DT02	C2	68Ω	DT02 MEM DATA IN 1(N+03) H
R38(1)	DT02	B2	68Ω	DT02 MEM DATA IN 1(N+04) H
R40(1)	DT02	A2	68Ω	DT02 MEM DATA IN 1(N+05) H
R1(1)	DT03	D5	68Ω	DT03 MEM DATA IN 0(N+06) H
R3(1)	DT03	C5	68Ω	DT03 MEM DATA IN 0(N+07) H
R100(1)	DT03	B5	68Ω	DT03 MEM DATA IN 0(N+08) H
R132(1)	DT03	D2	68Ω	DT03 MEM DATA IN 0(N+09) H
R35(1)	DT03	C2	68Ω	DT03 MEM DATA IN 0(N+10) H
R37(1)	DT03	B2	68Ω	DT03 MEM DATA IN 0(N+11) H
R5(1)	DT03	D5	68Ω	DT03 MEM DATA IN 1(N+06) H

RESISTOR LOC(PIN)	SHOWN ON DRW#	REF	VALUE	TERMINATES SIGNAL
R2(1)	DT03	B5	68Ω	DT03 MEM DATA IN 1(N+07) H
R99(1)	DT03	A5	68Ω	DT03 MEM DATA IN 1(N+08) H
R101(1)	DT03	D2	68Ω	DT03 MEM DATA IN 1(N+09) H
R34(1)	DT03	B2	68Ω	DT03 MEM DATA IN 1(N+10) H
R36(1)	DT03	A2	68Ω	DT03 MEM DATA IN 1(N+11) H
R162(1)	DT04	D5	68Ω	DT04 MEM DATA IN 0(N+12) H
R164(1)	DT04	C5	68Ω	DT04 MEM DATA IN 0(N+13) H
R158(1)	DT04	B5	68Ω	DT04 MEM DATA IN 0(N+14) H
R159(1)	DT04	D2	68Ω	DT04 MEM DATA IN 0(N+15) H
R119(1)	DT04	C2	68Ω	DT04 MEM DATA IN 0(N+16) H
R121(1)	DT04	B2	68Ω	DT04 MEM DATA IN 0(N+17) H
R161(1)	DT04	D5	68Ω	DT04 MEM DATA IN 1(N+12) H
R163(1)	DT04	B5	68Ω	DT04 MEM DATA IN 1(N+13) H
R157(1)	DT04	A5	68Ω	DT04 MEM DATA IN 1(N+14) H
R160(1)	DT04	D2	68Ω	DT04 MEM DATA IN 1(N+15) H
R110(1)	DT04	B2	68Ω	DT04 MEM DATA IN 1(N+16) H
R120(1)	DT04	A2	68Ω	DT04 MEM DATA IN 1(N+17) H
R122(1)	DT06	D2	68Ω	DT06 0(N/18+1, MEM PAR IN, SPARE9) H
R123(1)	DT06	D2	68Ω	DT06 1(N/18+1, MEM PAR IN, SPARE10) H
R98(1)	DT06	A1	68Ω	DT06 DATA TO MEM DISABLE A H
R168(1)	DT06	A1	68Ω	DT06 DATA TO MEM DISABLE B H
R182(1)	DT06	A1	68Ω	DT06 DATA TO MEM DISABLE C H
R4(1)	DT06	C6	68Ω	-DT06 SEL 0 H
R12(1)	DT02	D6	68Ω	MB [N+00] H
R9(1)	DT02	C6	68Ω	MB [N+01] H
R54(1)	DT02	B6	68Ω	MB [N+02] H
R55(1)	DT02	D3	68Ω	MB [N+03] H
R180(1)	DT02	C3	68Ω	MB [N+04] H
R179(1)	DT02	B3	68Ω	MB [N+05] H
R181(1)	DT03	D6	68Ω	MB [N+06] H
R170(1)	DT03	C6	68Ω	MB [N+07] H
R134(1)	DT03	B6	68Ω	MB [N+08] H
R133(1)	DT03	D3	68Ω	MB [N+09] H
R135(1)	DT03	C3	68Ω	MB [N+10] H
R136(1)	DT03	B3	68Ω	MB [N+11] H
R57(1)	DT04	D6	68Ω	MB [N+12] H
R11(1)	DT04	C6	68Ω	MB [N+13] H
R107(1)	DT04	B6	68Ω	MB [N+14] H
R106(1)	DT04	D3	68Ω	MB [N+15] H
R53(1)	DT04	C3	68Ω	MB [N+16] H

RESISTOR LOC(PIN)	SHOWN ON DRW#	REF	VALUE	TERMINATES SIGNAL
R108(1)	DT04	B3	68Ω	MB [N+17] H
R129(1)	DT01	C3	68Ω	MEM RQ [N/18+1, 0, 3] H
R206(1)	DT06	C3	68Ω	MEM [I] I
R214(1)	DT06	C3	68Ω	MEM [I] I2
R213(1)	DT06	C3	68Ω	MEM [I] I3
R126(1)	DT01	B3	68Ω	MEM [N/18+1, RQ 1, RD RQ] H
R127(1)	DT01	B3	68Ω	MEM [N/18+1, RQ 2, UR RQ] H
R56(1)	DT01	D3	68Ω	MEM [N/18+1, START A, STAR B] H
R195(1)	DT05	D3	68Ω	MEM [P/12+1, SPARE 33, SPARE32] H
R230(1)	DT05	D7	68Ω	PMA [P+14] H
R231(1)	DT05	D7	68Ω	PMA [P+15] H
R191(1)	DT05	D7	68Ω	PMA [P+16] H
R229(1)	DT05	D7	68Ω	PMA [P+17] H
R82(1)	DT05	D5	68Ω	PMA [P+18] H
R81(1)	DT05	D5	68Ω	PMA [P+19] H
R83(1)	DT05	D5	68Ω	PMA [P+20] H
R84(1)	DT05	D5	68Ω	PMA [P+21] H
R189(1)	DT01	B7	68Ω	[N/18+1, CLK SBUS, SPARE] CLK H
R59(1)	DT06	D3	68Ω	[N/18+1, MB PAR, SPARE7] H
R207(1)	DT06	C2	68Ω	[N/18+1, MB23 SEQ RQ, MEM DATA TO MEM] H
R96(1)	DT01	A3	68Ω	-(N/18+1, MEM DIAG, -MEM ADR PAR) H
R225(1)	DT06	D6	68Ω	[N/18+1, MEM SPARE, DIAG MEM RESET] H
R226(1)	DT05	C7	68Ω	[N/18+1, SBUS ADR HOLD H, MEM TERM 18] H
R192(1)	DT05	D3	68Ω	[P/12+1, PMA 22, SBUS ADR 34] H
R193(1)	DT05	D3	68Ω	[P/12+1, PMA 23, SBUS ADR 35] H
R194(1)	DT05	D3	68Ω	[P/12+1, PMA 24, PMA 25] H

NOTE:  
 1. ALL TERMINATORS HAVE PIN TWO CONNECTED TO -2.0V AND ARE 5% 1/4WATT UNLESS OTHERWISE SPECIFIED  
 2. ENTRIES ARE SORTED BY SIGNAL NAME  
 3. % INDICATES OUTPUT OF DIP LOC AND ( ) INDICATES PIN NUMBER

THIS DRAWING AND SPECIFICATIONS HEREIN ARE THE PROPERTY OF DIGITAL EQUIPMENT CORPORATION AND SHALL NOT BE REPRODUCED OR COPIED OR USED IN WHOLE OR IN PART AS THE BASIS FOR THE MANUFACTURE OR SALE OF ITEMS WITHOUT WRITTEN PERMISSION. COPYRIGHT © 1978, DIGITAL EQUIPMENT CORPORATION.

REVISIONS		
CHK	CHANGE NO.	REV

digital DRN. G. Smith DATE 09-JUN-78 ENG. J. Chen DATE 24-JUN-78  
 CHK. J. Lucas DATE 18-JUL-78 SHEET 1 OF 1  
 F05801.DRW(4,672) 09-JUN-78 09:11 NEXT HIGHER ASSEMBLY: D-DD-M8580-0

DATE 09-JUN-78 ENG. J. Chen DATE 24-JUN-78  
 BOARD LOCATION:  
 TITLE: DUAL TRANSLATOR TERMINATORS

SIZE	CODE	NUMBER	REV.
D	CS	M8580-0-RES	

REV. NUMBER M8580-0-RES  
 SIZE CODE CS  
 D CS

DRAWING NUMBER	PAGE	PART NO.	DESCRIPTION	REVISIONS	
			ECO NUMBER	-	1
		M8581-00	MODULE REVISION	A	A1
D-LJA-M8581-0-0	5		XBUS TRANSLATOR	A	A
K-PL-M8581-0-DBP	2		PARTS LIST, M8581	A	B
D-CS-M8581-0-DX01	1		XBUS TRANSLATOR	-	-
D-CS-M8581-0-DX02	1		DATA TRNCVR 0-5	-	-
D-CS-M8581-0-DX03	1		DATA TRNCVR 6-11	-	-
D-CS-M8581-0-DX04	1		DATA TRNCVR 12-17	-	-
D-CS-M8581-0-DX05	1		ADDRESS DRIVERS	-	-
D-CS-M8581-0-DX06	1		CTRL & REF VOLT	-	A
D-CS-M8581-0-DX07	1		POWER, GND, CAPS.	-	-
D-CS-M8581-0-RES	1		TERMINATORS	-	-
K-PC-M8581-0-DBC	-		CALDEC DESIGN DATA BASE	A	A
D-DD-5013219-0	1		DRAWING DIRECTORY, 5013219	REF	REF
P00-M8581-00	-		PROCESS SHEET (REF ONLY)	-	-

THIS DRAWING AND SPECIFICATIONS  
 HEREIN ARE THE PROPERTY OF  
 DIGITAL EQUIPMENT CORPORATION AND  
 SHALL NOT BE REPRODUCED OR COPIED  
 OR USED IN WHOLE OR IN PART AS  
 THE BASIS FOR THE MANUFACTURE OR  
 SALE OF ITEMS WITHOUT WRITTEN  
 PERMISSION. COPYRIGHT © 1984  
 DIGITAL EQUIPMENT CORPORATION

REVISIONS		
CHK	CHANGE NO.	REV

digital

DRN D. DELLORCO	DATE 09-NOV-84	ENG D. Dellorco	DATE 09-NOV-84	TITLE DRAWING DIRECTORY
CHK'D D. Dellorco	DATE 09-NOV-84	BOARD LOCATION N/A	SHEET 1 OF 1	NUMBER M8581
DSK:M8581A.T2PL4.351		NEXT HIGHER ASSEMBLY: N/A		REV. A

SIZE CODE D DD	NUMBER M8581-0	REV. A
-------------------	-------------------	-----------

THIS DRAWING AND SPECIFICATIONS, HEREIN, AND THE PROPERTY OF AIRTEL EQUIPMENT COMPANY AND SHALL NOT BE REPRODUCED OR TRANSMITTED IN ANY FORM OR BY ANY MEANS, ELECTRONIC OR MECHANICAL, INCLUDING PHOTOCOPYING, RECORDING, OR BY ANY INFORMATION STORAGE AND RETRIEVAL SYSTEM.

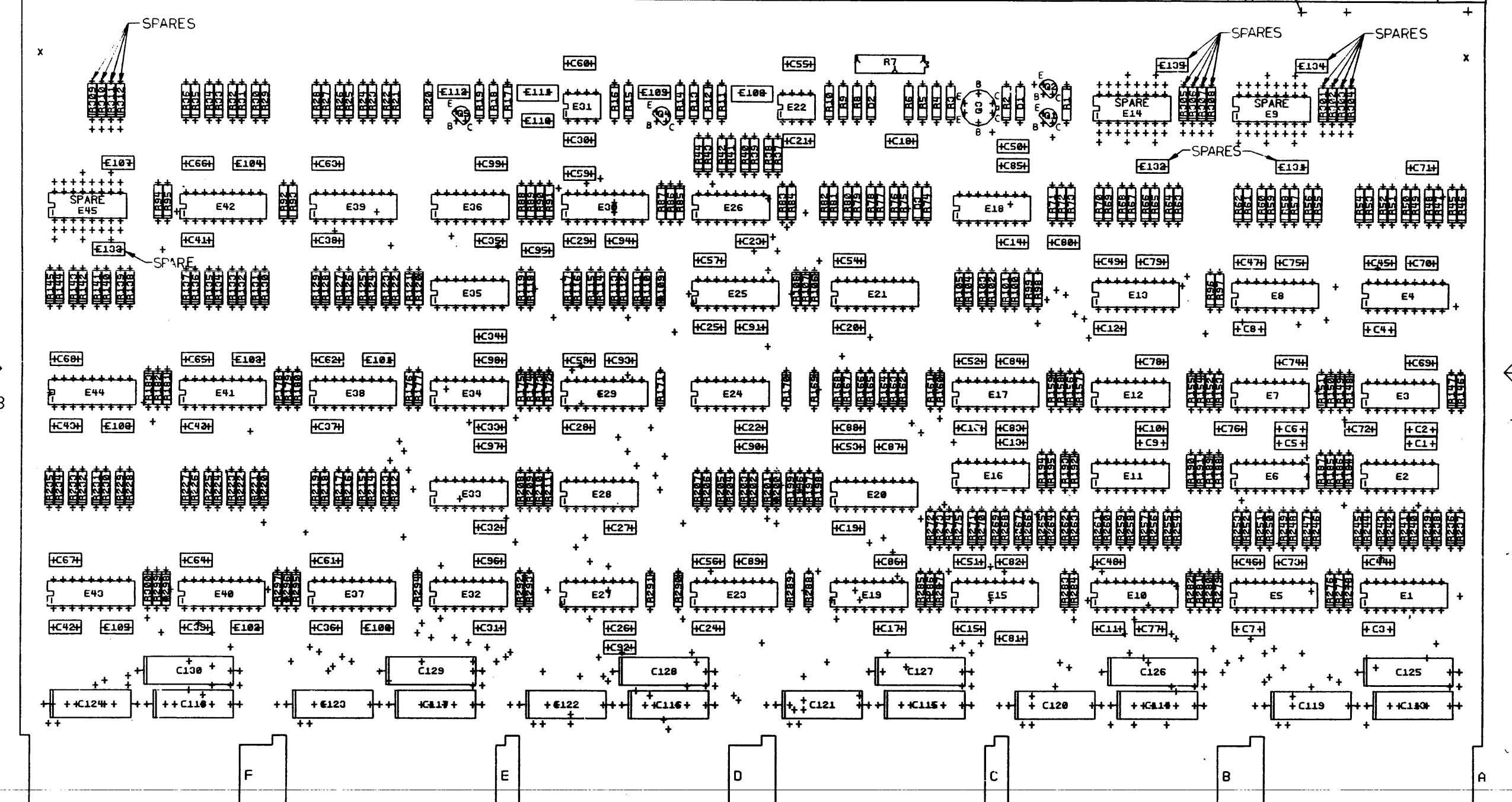
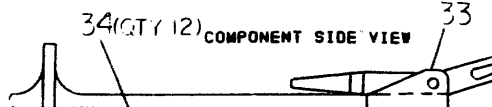

VUTSRPNMLKJHFEDCBA VUTSRPNMLKJHFEDCBA VUTSRPNMLKJHFEDCBA VUTSRPNMLKJHFEDCBA VUTSRPNMLKJHFEDCBA VUTSRPNMLKJHFEDCBA

NOTES:

CHANGE NO	REV

ETCH REV.	B
P.C. DESIGN DATA BRSE REV.	A

SIGNATURES		DATE	digital
DRN.			
CHK'D BY			TITLE
ENG.			XBUS
PROJ. ENG.			TRANSLATOR
PROD.			
SCALE	2/1	SIZE	CODE
SHT. 1 OF 5		NUMBER	
NEXT HIGHER ASSY. D-DD-18581-0			

D  
C  
B  
A

D  
C  
B  
A

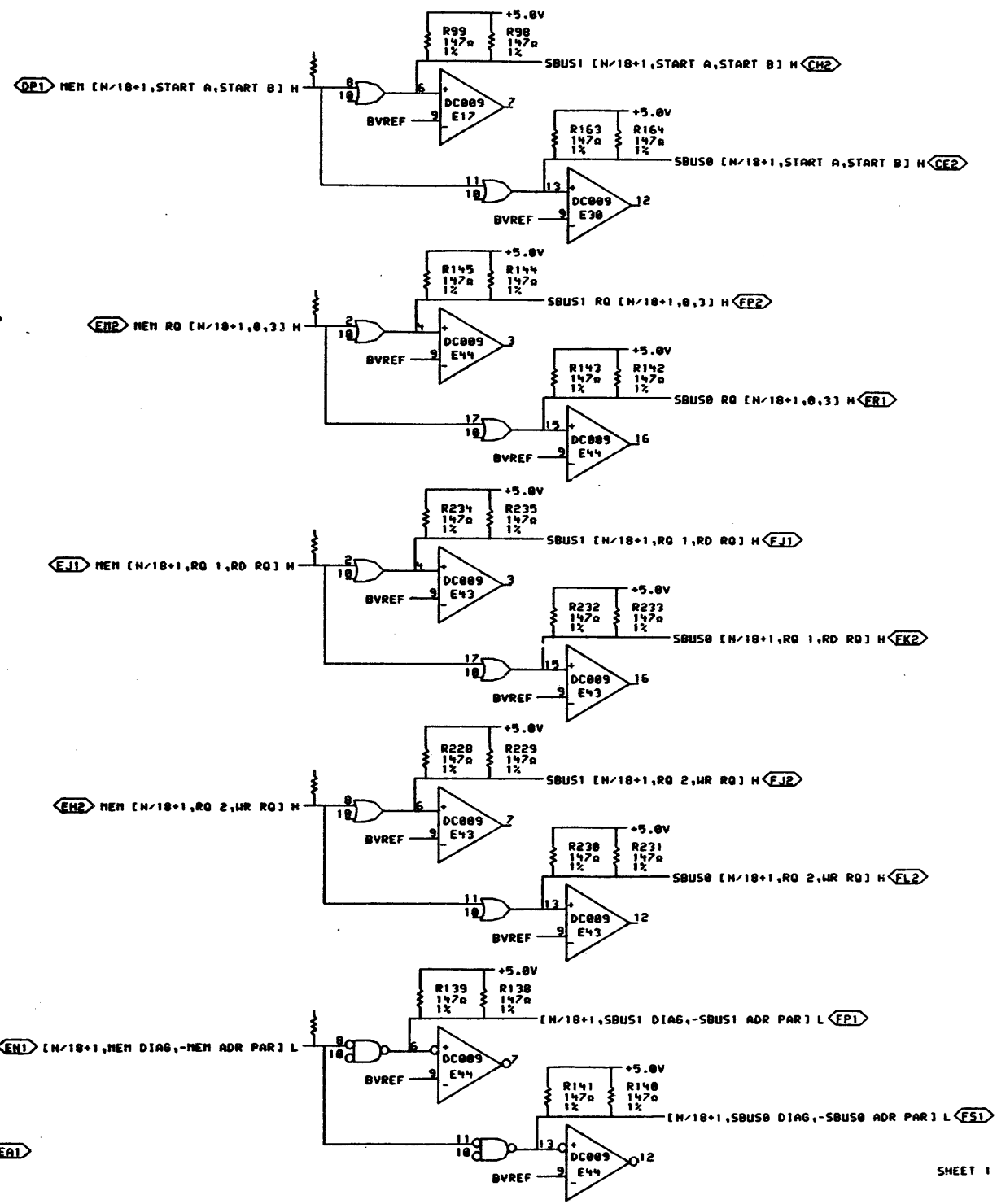
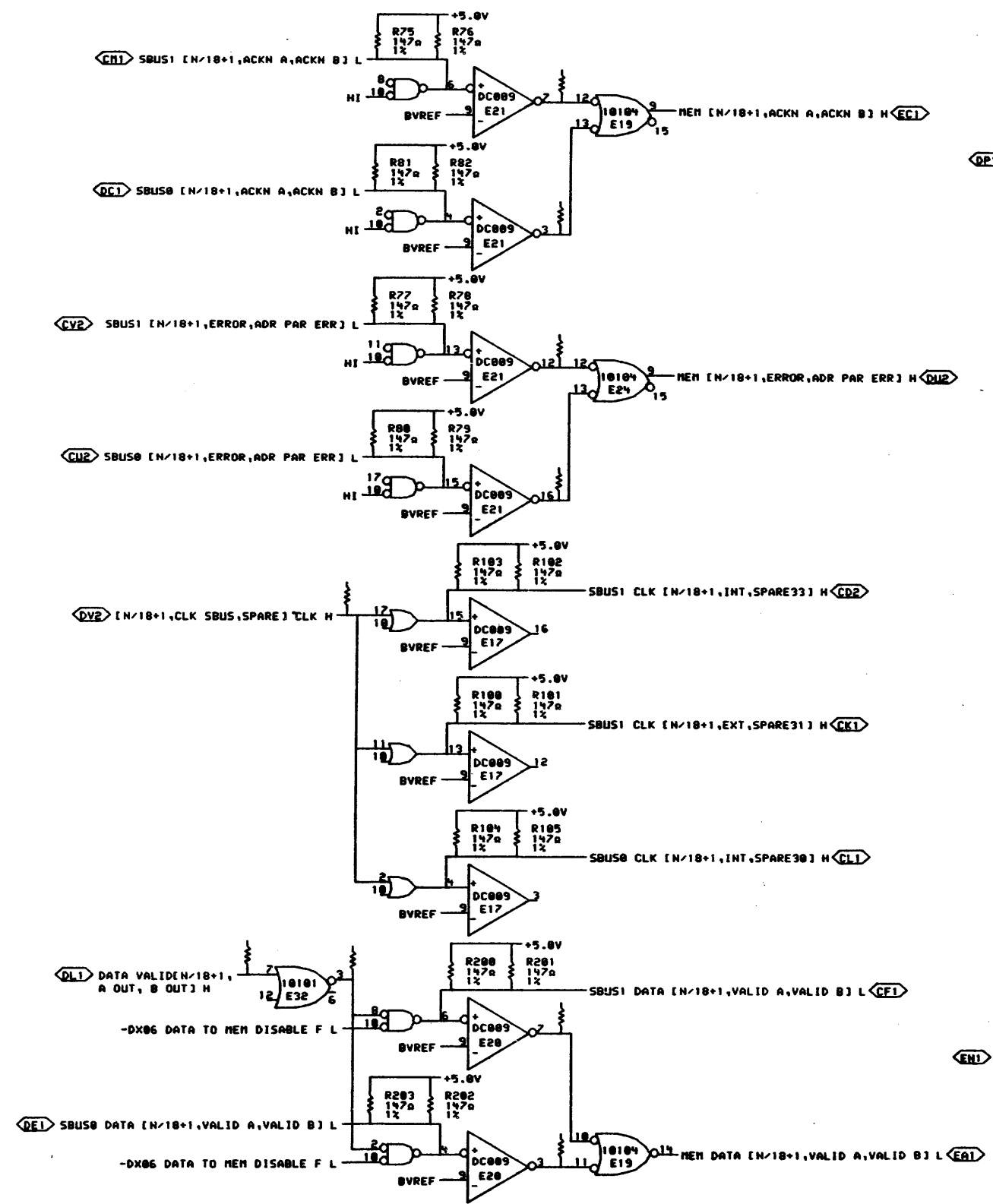

SHEET 1 OF 7

THIS DRAWING AND SPECIFICATIONS ARE THE PROPERTY OF DIGITAL EQUIPMENT CORPORATION AND SHALL NOT BE REPRODUCED OR COPIED OR USED IN WHOLE OR IN PART AS THE BASIS FOR THE MANUFACTURE OR SALE OF ITEMS WITHOUT WRITTEN PERMISSION. COPYRIGHT © 1970, DIGITAL EQUIPMENT CORPORATION.		<b>REVISIONS</b> CHK CHANGE NO. REV	<b>digital</b> DRN <i>Edw...</i> DATE <i>11/11/78</i> ENG <i>11/11/78</i> DATE <i>11/11/78</i> TITLE: XBUS TRANSLATOR PUB: (M8581-MOS)DX01B, DRU126-JUL-78 09:07 NEXT HIGHER ASSEMBLY: SHEET 1 OF 1 FIRST USED ON OPTION/MODEL: MF20 D-DD-M8581-0	SIZE CODE NUMBER REV. D CS M8581-0-DX01
--	--	--	---	--

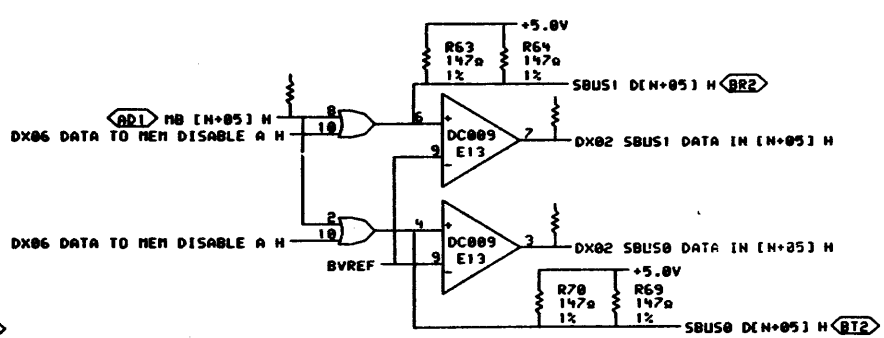
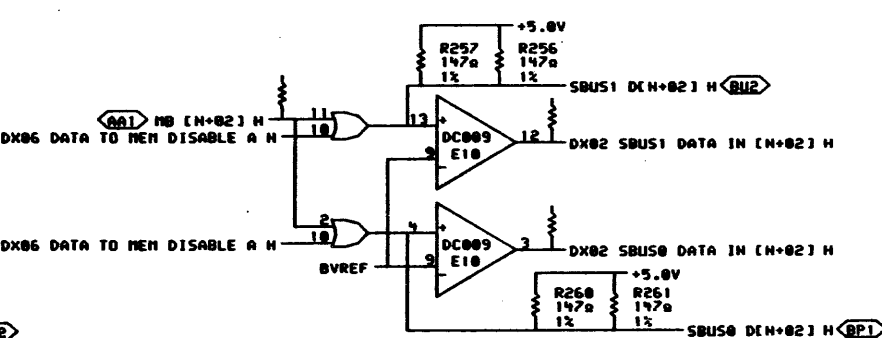
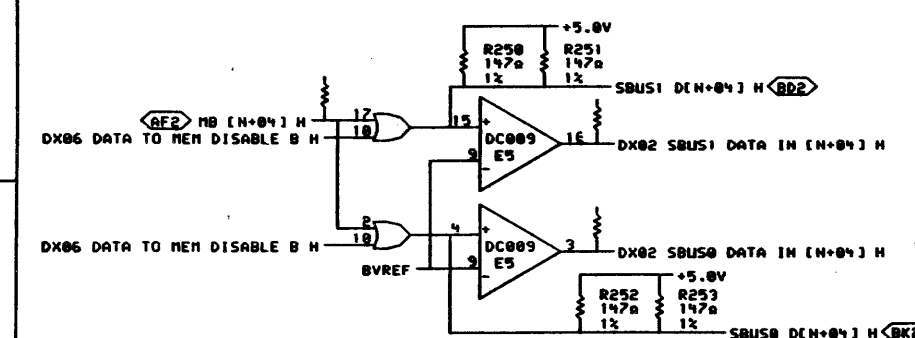
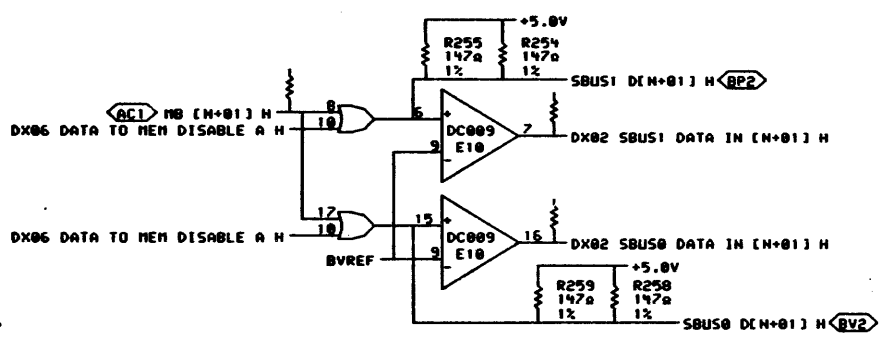
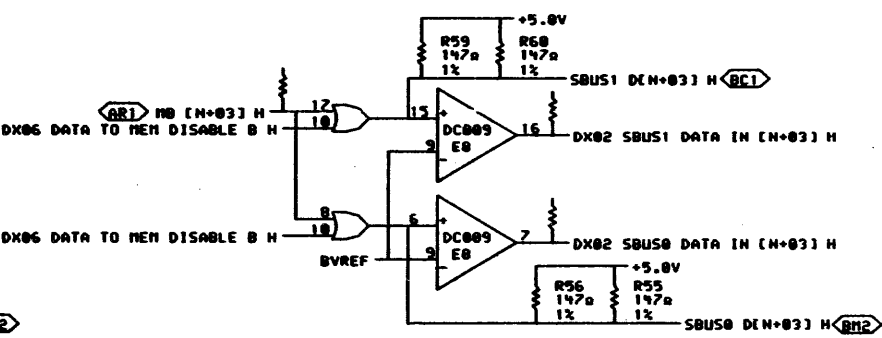
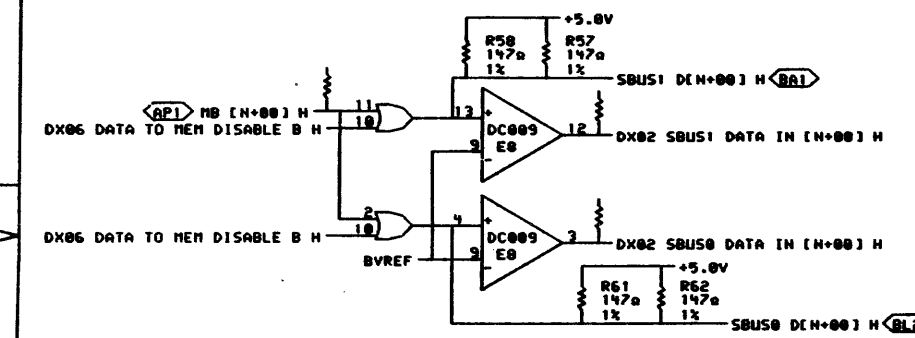
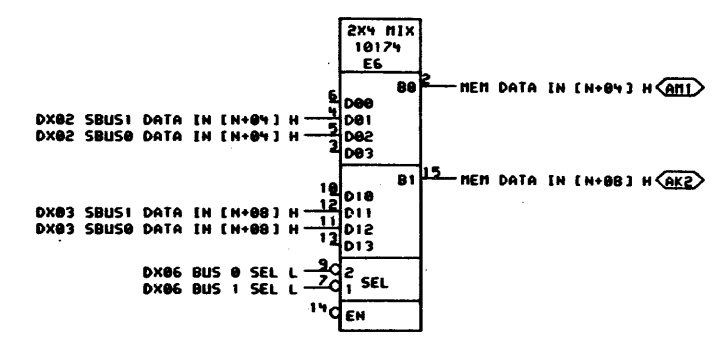
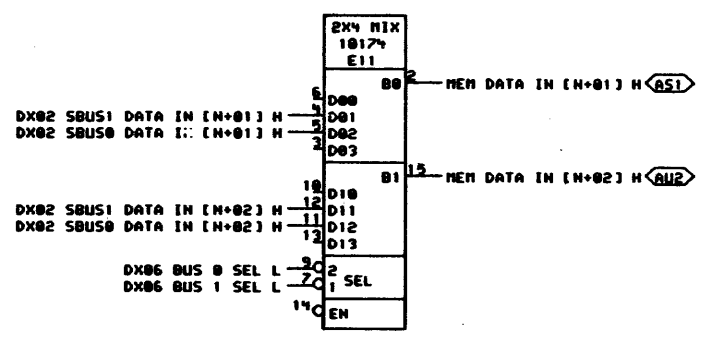
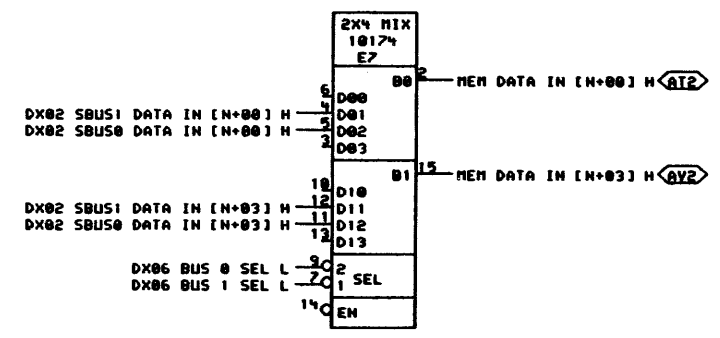

SHEET 2 OF 7

THIS DRAWING AND SPECIFICATIONS HEREIN, ARE THE PROPERTY OF DIGITAL EQUIPMENT CORPORATION AND SHALL NOT BE REPRODUCED OR COPIED OR USED IN WHOLE OR IN PART AS THE BASIS FOR THE MANUFACTURE OR SALE OF ITEMS WITHOUT WRITTEN PERMISSION. COPYRIGHT © 1970, DIGITAL EQUIPMENT CORPORATION.

REVISIONS	
CHK	CHANGE NO. REV.

--	--	--	--	--	--	--	--	--	--

digital	DRN	DATE	ENG	DATE	TITLE: XBUS TRANSLATOR DATA TRNCVR 0-5		
	CHK'D	DATE					
FIRST USED ON OPTION/MODEL: MF20					SIZE CODE	NUMBER	REV.
					D	CS	M8581-0-DX02

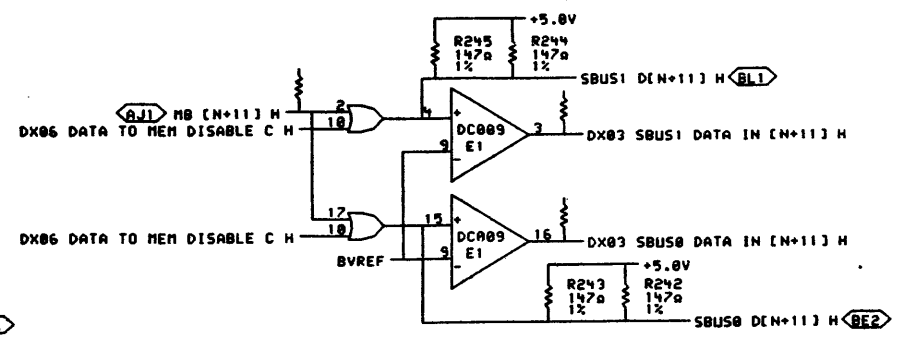
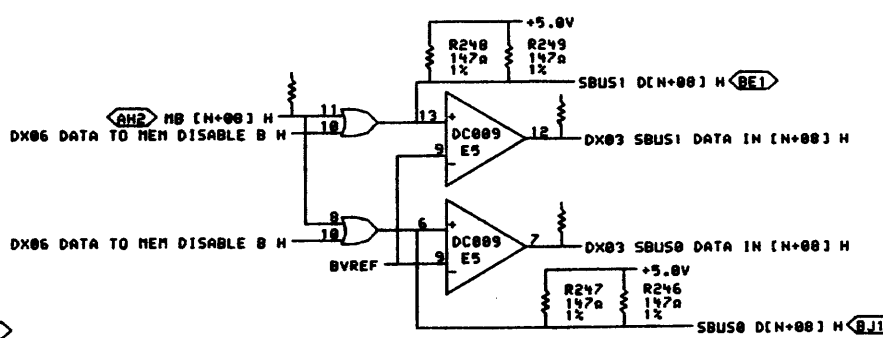
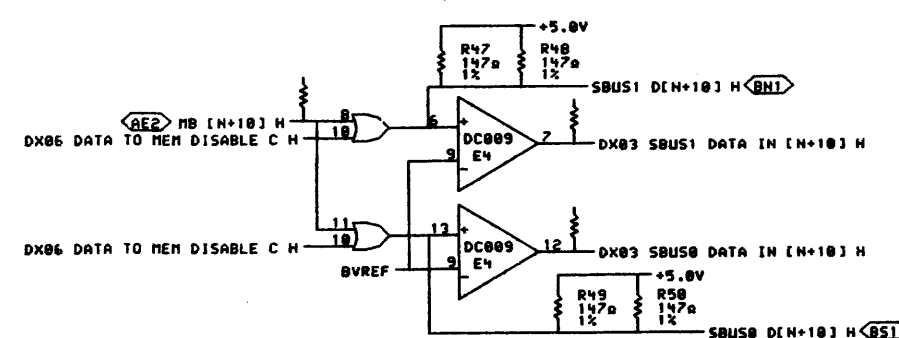
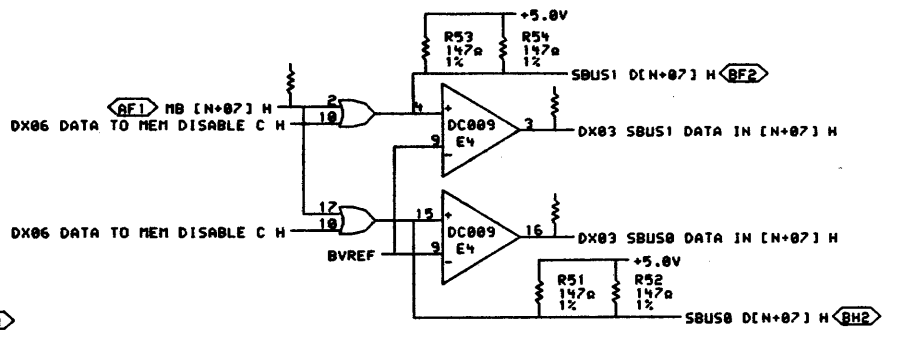
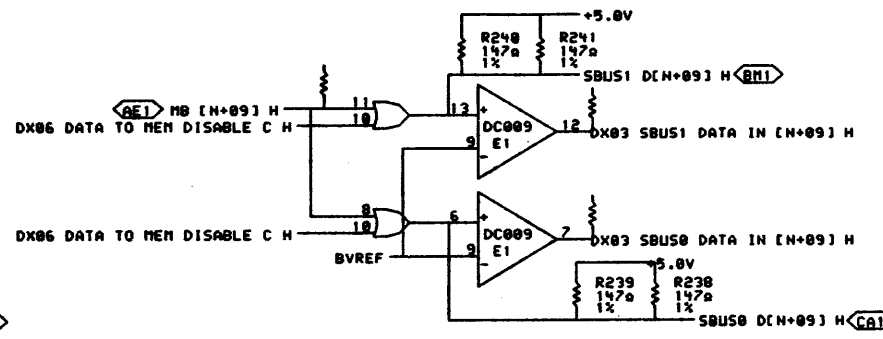
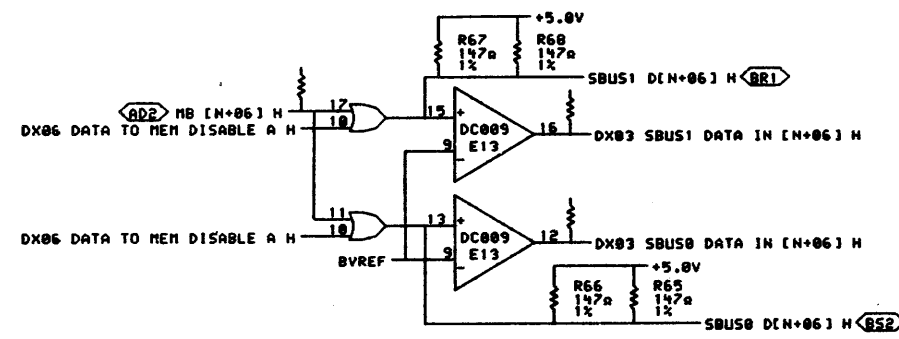
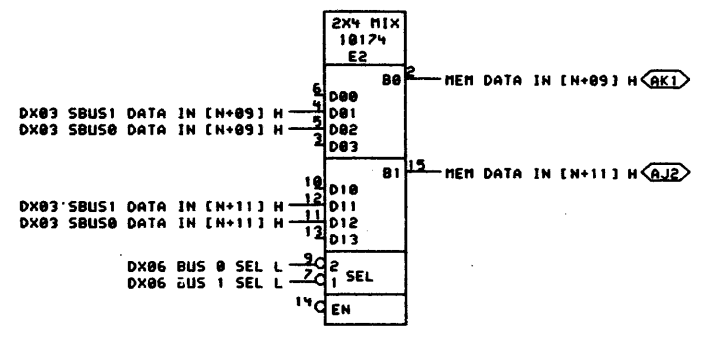
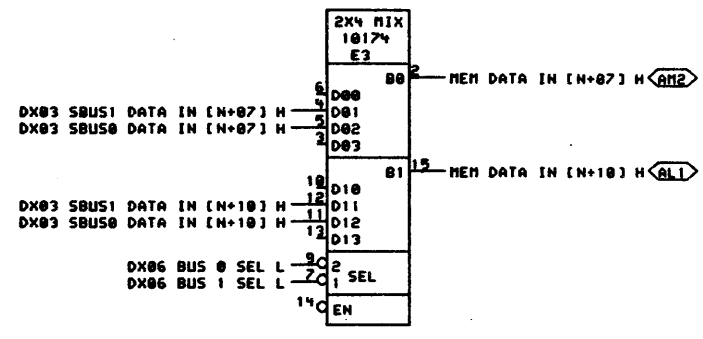
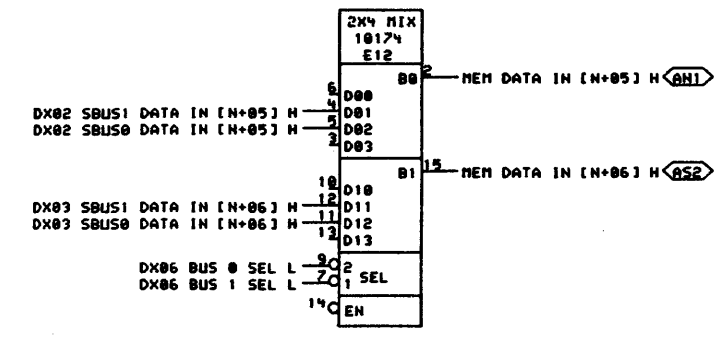

SHEET 3 OF 7

THIS DRAWING AND SPECIFICATIONS HEREIN ARE THE PROPERTY OF DIGITAL EQUIPMENT CORPORATION AND SHALL NOT BE REPRODUCED OR COPIED OR USED IN WHOLE OR IN PART AS THE BASIS FOR THE MANUFACTURE OR SALE OF ITEMS WITHOUT WRITTEN PERMISSION. COPYRIGHT © 1978. DIGITAL EQUIPMENT CORPORATION.

REVISIONS	
CHK	CHANGE NO. REV

**digital** DRN *P. Luciani* DATE *25-28-78* ENR *Allen T. Ho* DATE *2/28/78*  
 CHG'D DATE BOARD LOCATION: *1* OF *1*  
 PUB: M8581-005-DX03, DRW: 26-JUL-78 00:13 SHEET 1 OF 1  
 FIRST USED ON OPTION/MODEL: MF20 D-DD-M8581-0

TITLE: XBUS TRANSLATOR DATA TRNCVR 6-11  
 SIZE CODE NUMBER REV.  
 D CS M8581-0-DX03 me 1

REV. 1  
 NUMBER M8581-0-DX03  
 SIZE CODE D CS  
 B

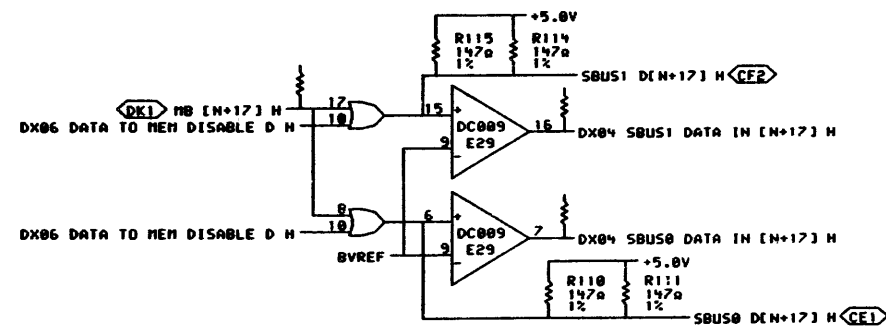
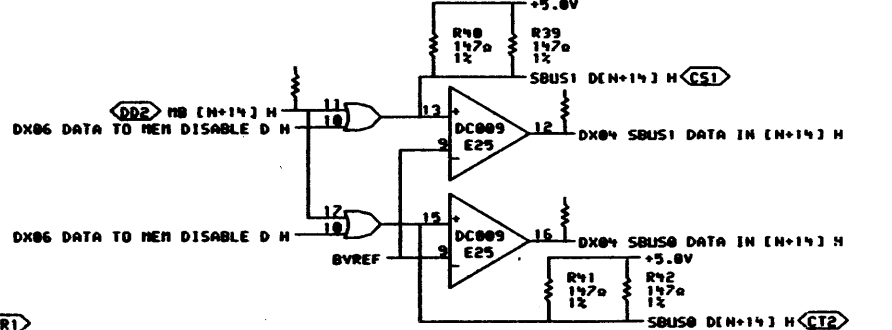
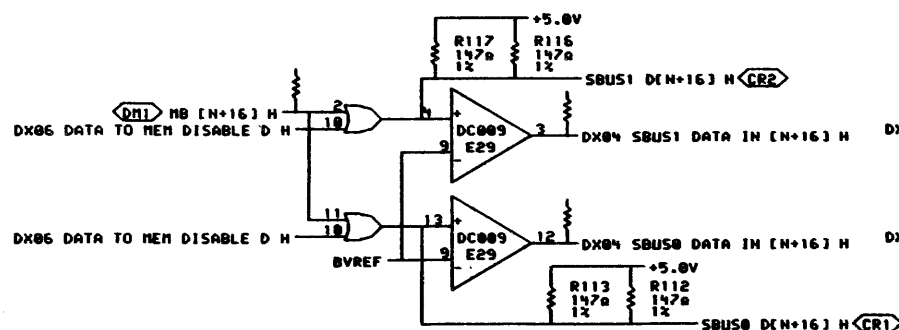
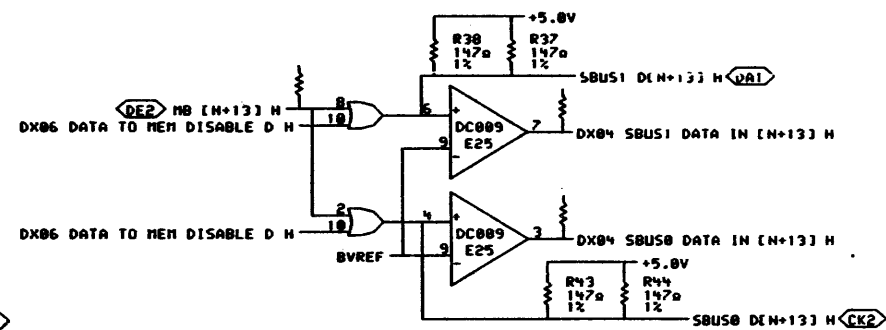
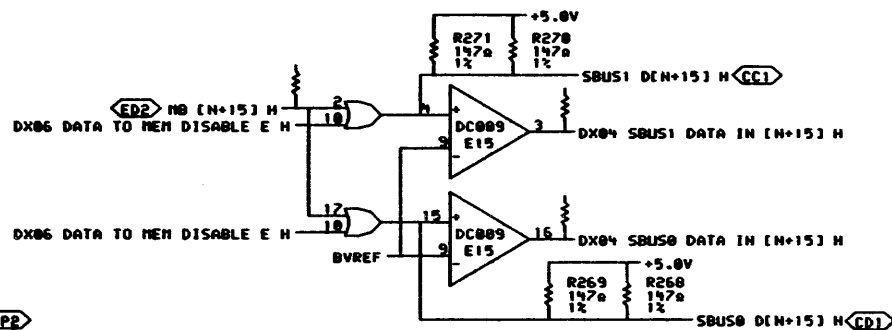
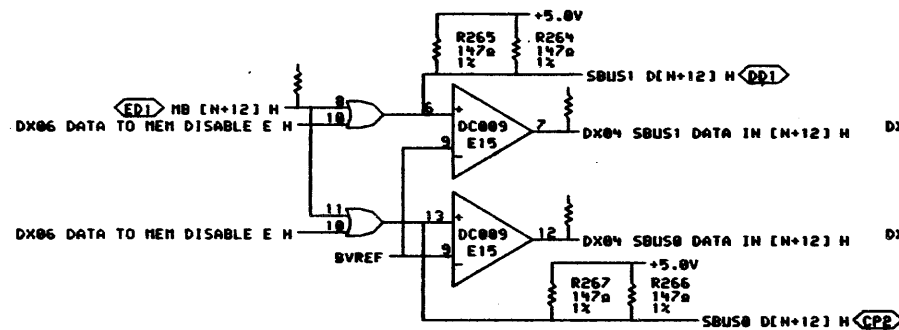
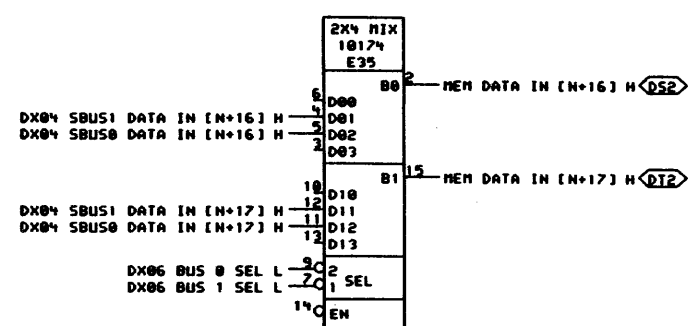
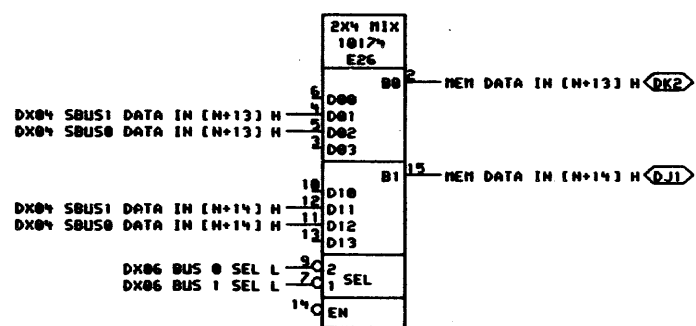
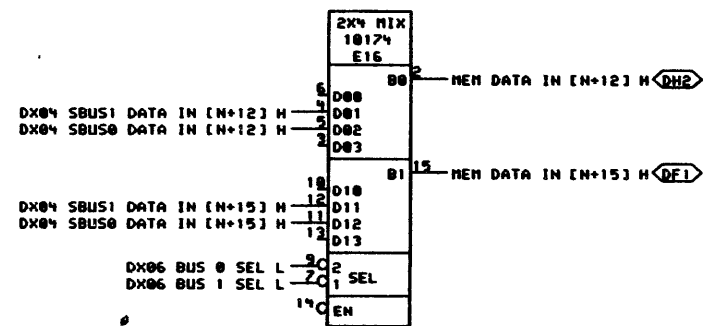

THIS DRAWING AND SPECIFICATIONS ARE THE PROPERTY OF DIGITAL EQUIPMENT CORPORATION AND SHALL NOT BE REPRODUCED OR COPIED OR USED IN WHOLE OR IN PART AS THE BASIS FOR THE MANUFACTURE OR SALE OF ITEMS WITHOUT WRITTEN PERMISSION. COPYRIGHT © 1979, DIGITAL EQUIPMENT CORPORATION.

REVISIONS	
CHK	CHANGE NO. REV

digital	DRN <i>Edwards</i>	DATE <i>25-JUL-78</i>	ENG <i>Allen H. 2</i>	DATE <i>Aug 78</i>	TITLE: XBUS TRANSLATOR
	CHK <i>Edwards</i>	DATE <i>25-JUL-78</i>	BOARD LOCATION: <i> </i>	SHEET <i>4</i> OF <i>7</i>	DATA TRNCVR 12-17
FIRST USED ON OPTION/MODEL: MF20			NEXT HIGHER ASSEMBLY: D-DD-M8581-0		SIZE CODE NUMBER REV.
					D CS M8581-0-DX04

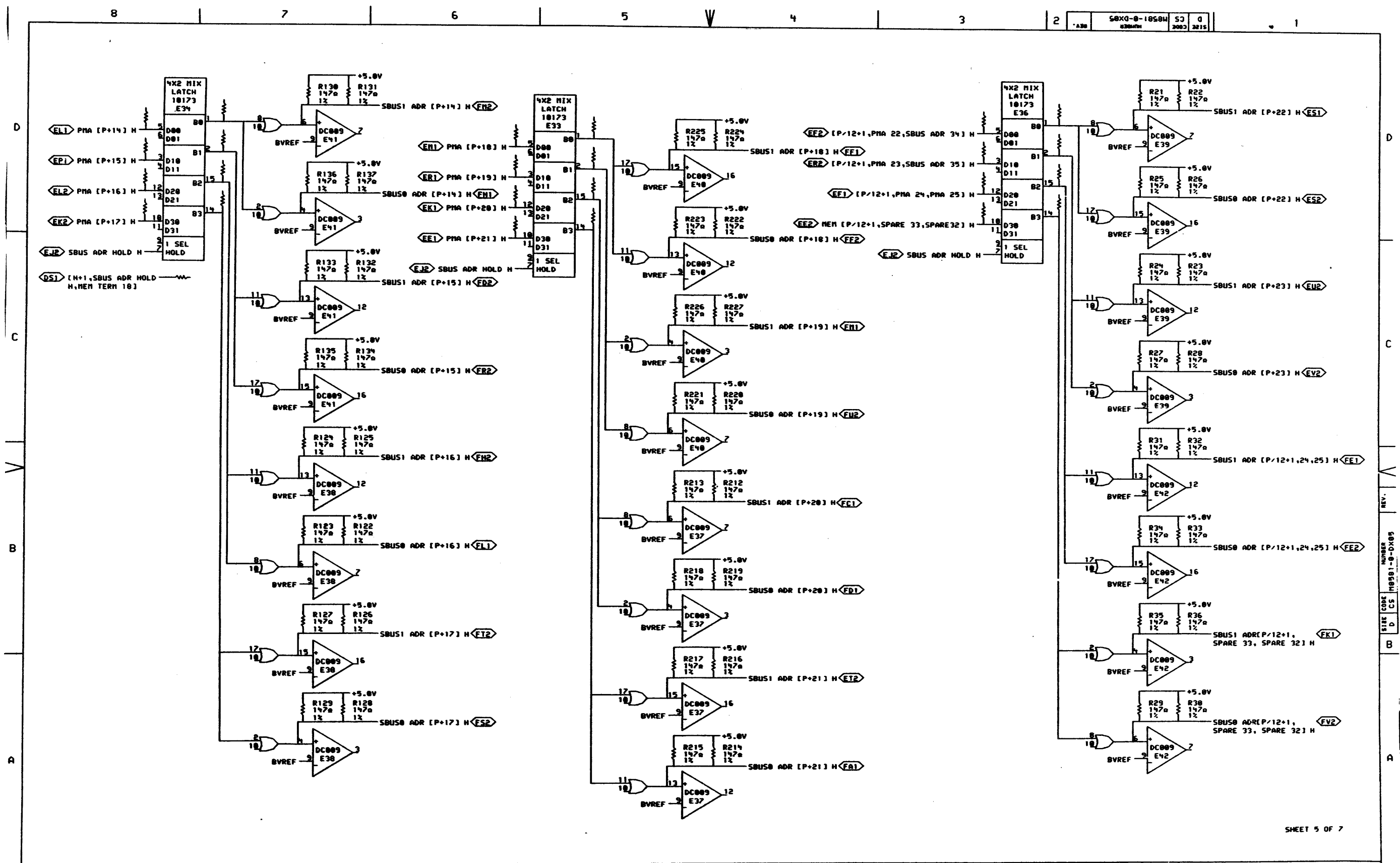

SHEET 5 OF 7

THIS DRAWING AND SPECIFICATIONS HEREIN ARE THE PROPERTY OF DIGITAL EQUIPMENT CORPORATION AND SHALL NOT BE REPRODUCED OR COPIED OR USED IN WHOLE OR IN PART AS THE BASIS FOR THE MANUFACTURE OR SALE OF ITEMS WITHOUT WRITTEN PERMISSION. COPYRIGHT © 1976, DIGITAL EQUIPMENT CORPORATION.

REVISIONS		
CHK	CHANGE NO.	REV

**digital** DRM *Educion* DATE ENG. *11/11/76* DATE *11/11/76*  
 CH. D. DATE BOARD LOCATION: *11/11/76*  
 PURI (M8581-M8581-DX05) DRAW 26-ML-78 00:27 NEXT HIGHER ASSEMBLY: *11/11/76*  
 FIRST USED ON OPTION/MODEL: MF20 D-DD-M8581-0

TITLE:	XBUS TRANSLATOR ADDRESS DRIVERS		
SIZE CODE	D	CS	M8581-0-DX05
NUMBER	1		
REV.			

REV. NUMBER 18581-0-DX05  
 SIZE CODE CS D  
 B

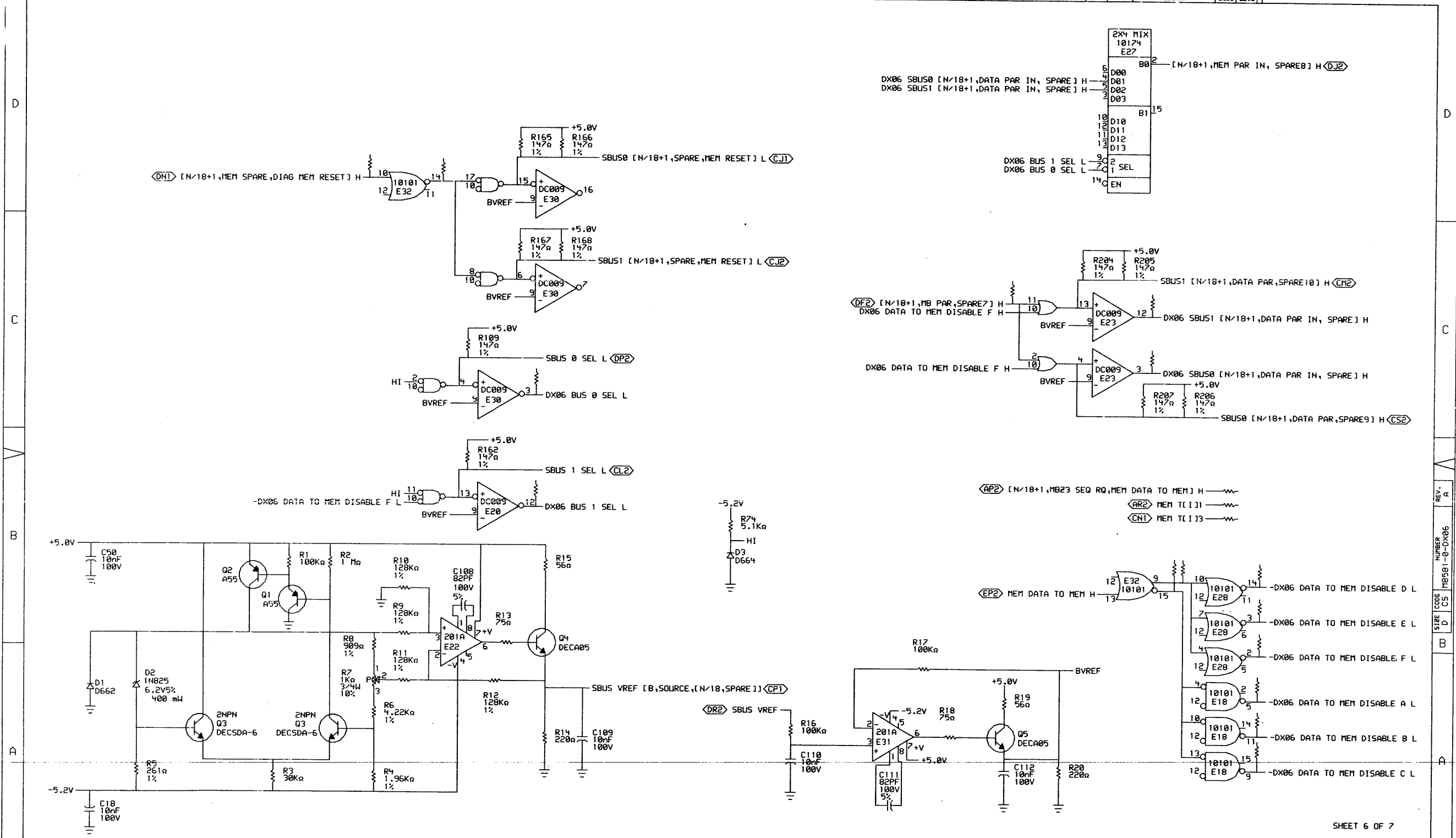

SHEET 6 OF 7

THIS DRAWING AND SPECIFICATIONS ARE THE PROPERTY OF DIGITAL EQUIPMENT CORPORATION AND SHALL NOT BE REPRODUCED OR COPIED OR USED IN WHOLE OR IN PART AS THE BASIS FOR THE MANUFACTURE OR SALE OF ITEMS WITHOUT WRITTEN PERMISSION. COPYRIGHT © 1984, DIGITAL EQUIPMENT CORPORATION.

REVISIONS	
CHK	CHANGE NO. REV

	DATE: 08-NOV-84	ENG: [Signature]	DATE: 9 Nov 84	TITLE: XBUS TRANSLATOR CTRL & REF VOLT
	CHK'D: [Signature]	DATE: 12 NOV 84	BOARD LOCATION: [Blank]	SIZE: D
SUBCON: [Blank]		NEXT HIGHER ASSEMBLY: D-DD-M8581-0		CODE: CS
FIRST USED ON OPTION/MODEL: MF20		D-DD-M8581-0		NUMBER: M8581-0-DX06
REV. A				MR0 1

REV. A  
NUMBER M8581-0-DX06  
SIZE CODE CS

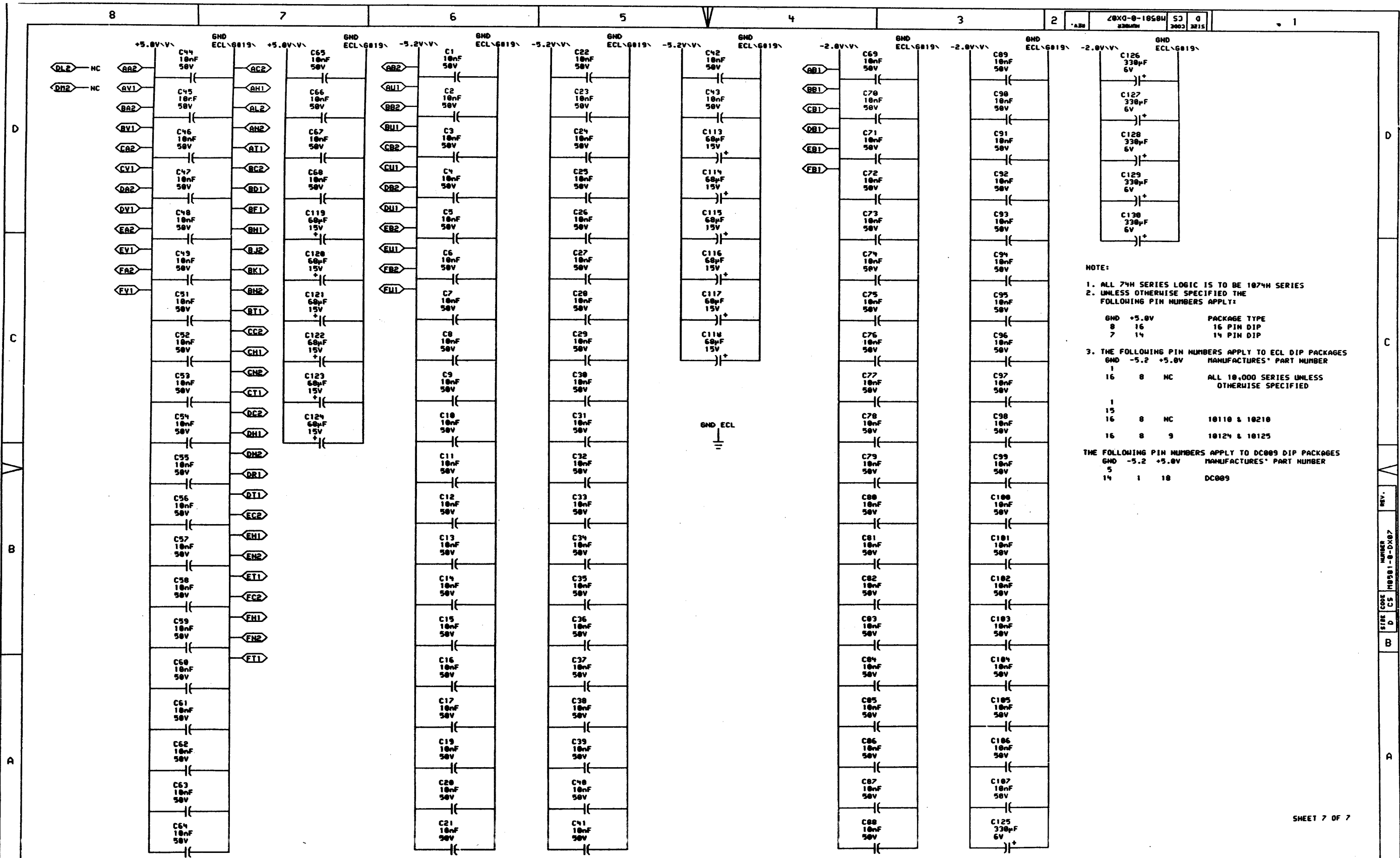

NOTE:

- ALL 74H SERIES LOGIC IS TO BE 1074H SERIES
- UNLESS OTHERWISE SPECIFIED THE FOLLOWING PIN NUMBERS APPLY:

GND	+5.0V	PACKAGE TYPE
8	16	16 PIN DIP
7	14	14 PIN DIP

- THE FOLLOWING PIN NUMBERS APPLY TO ECL DIP PACKAGES

GND	-5.2	+5.0V	MANUFACTURER'S PART NUMBER
1			ALL 10,000 SERIES UNLESS OTHERWISE SPECIFIED
16	8	NC	
1			
15			
16	8	NC	10110 & 10210
16	8	9	10124 & 10125

- THE FOLLOWING PIN NUMBERS APPLY TO DC009 DIP PACKAGES

GND	-5.2	+5.0V	MANUFACTURER'S PART NUMBER
5			
14	1	18	DC009

SHEET 7 OF 7

THIS DRAWING AND SPECIFICATIONS ARE THE PROPERTY OF DIGITAL EQUIPMENT CORPORATION AND SHALL NOT BE REPRODUCED OR COPIED OR USED IN WHOLE OR IN PART AS THE BASIS FOR THE MANUFACTURE OR SALE OF ITEMS WITHOUT WRITTEN PERMISSION. COPYRIGHT © 1979, DIGITAL EQUIPMENT CORPORATION

REVISIONS		
CHK	CHANGE NO.	REV

	DATE: 12-17-79	ENG: [Signature]	DATE: [Signature]	TITLE: XBUS TRANSLATOR POWER, GND, CAPS.
	DATE: [Signature]	DATE: [Signature]	DATE: [Signature]	DATE: [Signature]
SHEET 7 OF 7 NEXT HIGHER ASSEMBLY:				SIZE CODE: D NUMBER: CS NUMBER: M8581-0-DX07 REV.:
FIRST USED ON OPTION/MODEL: MF20				D-DD-M8581-0

SITE CODE CS  
 NUMBER M8581-0-DX07  
 REV.

RESISTOR LOC(PIN)	SHOWN ON DRUM REF	VALUE	TERMINATES SIGNAL
R273(1)	DX01 A6	60a	XE20(3)
R274(1)	DX01 A6	60a	XE20(7)
R178(1)	DX01 C6	60a	XE21(12)
R169(1)	DX01 C6	60a	XE21(16)
R198(1)	DX01 D6	60a	XE21(3)
R272(1)	DX01 D6	60a	XE21(7)
R87(1)	DX06 D6	60a	XE32(14)
R71(1)	DX06 B2	60a	XE32(15)
R197(1)	DX01 A7	60a	XE32(3)
R171(1)	DX06 B2	60a	XE32(9)
R297(1)	DX05 D5	60a	XE33(1)
R295(1)	DX05 D5	60a	XE33(14)
R296(1)	DX05 D5	60a	XE33(15)
R298(1)	DX05 D5	60a	XE33(2)
R178(1)	DX05 D7	60a	XE34(1)
R100(1)	DX05 D7	60a	XE34(14)
R179(1)	DX05 D7	60a	XE34(15)
R181(1)	DX05 D7	60a	XE34(2)
R92(1)	DX05 D2	60a	XE36(1)
R95(1)	DX05 D2	60a	XE36(14)
R94(1)	DX05 D2	60a	XE36(15)
R93(1)	DX05 D2	60a	XE36(2)
R292(1)	DX01 A7	60a	DATA VALID(N/10+1, A OUT, B OUT) H
R152(1)	DX02 B7	60a	DX02 SBUS0 DATA IN [N+00] H
R194(1)	DX02 B2	60a	DX02 SBUS0 DATA IN [N+01] H
R192(1)	DX02 A4	60a	DX02 SBUS0 DATA IN [N+02] H
R154(1)	DX02 B4	60a	DX02 SBUS0 DATA IN [N+03] H
R190(1)	DX02 A7	60a	DX02 SBUS0 DATA IN [N+04] H
R156(1)	DX02 A2	60a	DX02 SBUS0 DATA IN [N+05] H
R153(1)	DX02 C7	60a	DX02 SBUS1 DATA IN [N+00] H
R195(1)	DX02 C2	60a	DX02 SBUS1 DATA IN [N+01] H
R193(1)	DX02 B4	60a	DX02 SBUS1 DATA IN [N+02] H
R155(1)	DX02 C4	60a	DX02 SBUS1 DATA IN [N+03] H
R191(1)	DX02 B7	60a	DX02 SBUS1 DATA IN [N+04] H
R157(1)	DX02 B2	60a	DX02 SBUS1 DATA IN [N+05] H
R150(1)	DX03 B7	60a	DX03 SBUS0 DATA IN [N+06] H
R146(1)	DX03 B2	60a	DX03 SBUS0 DATA IN [N+07] H
R189(1)	DX03 A4	60a	DX03 SBUS0 DATA IN [N+08] H
R185(1)	DX03 B4	60a	DX03 SBUS0 DATA IN [N+09] H
R140(1)	DX03 A7	60a	DX03 SBUS0 DATA IN [N+10] H

RESISTOR LOC(PIN)	SHOWN ON DRUM REF	VALUE	TERMINATES SIGNAL
R187(1)	DX03 A2	60a	DX03 SBUS0 DATA IN [N+11] H
R159(1)	DX03 C7	60a	DX03 SBUS1 DATA IN [N+06] H
R147(1)	DX03 C2	60a	DX03 SBUS1 DATA IN [N+07] H
R180(1)	DX03 B4	60a	DX03 SBUS1 DATA IN [N+08] H
R186(1)	DX03 C4	60a	DX03 SBUS1 DATA IN [N+09] H
R149(1)	DX03 B7	60a	DX03 SBUS1 DATA IN [N+10] H
R184(1)	DX03 B2	60a	DX03 SBUS1 DATA IN [N+11] H
R286(1)	DX04 B7	60a	DX04 SBUS0 DATA IN [N+12] H
R84(1)	DX04 B2	60a	DX04 SBUS0 DATA IN [N+13] H
R85(1)	DX04 A4	60a	DX04 SBUS0 DATA IN [N+14] H
R287(1)	DX04 B4	60a	DX04 SBUS0 DATA IN [N+15] H
R119(1)	DX04 A7	60a	DX04 SBUS0 DATA IN [N+16] H
R121(1)	DX04 A2	60a	DX04 SBUS0 DATA IN [N+17] H
R285(1)	DX04 C7	60a	DX04 SBUS1 DATA IN [N+12] H
R83(1)	DX04 C2	60a	DX04 SBUS1 DATA IN [N+13] H
R86(1)	DX04 B4	60a	DX04 SBUS1 DATA IN [N+14] H
R288(1)	DX04 C4	60a	DX04 SBUS1 DATA IN [N+15] H
R118(1)	DX04 B7	60a	DX04 SBUS1 DATA IN [N+16] H
R120(1)	DX04 B2	60a	DX04 SBUS1 DATA IN [N+17] H
R150(1)	DX06 C6	60a	-DX06 BUS 0 SEL H
R151(1)	DX06 B6	60a	-DX06 BUS 1 SEL H
R282(1)	DX06 A1	60a	DX06 DATA TO MEN DISABLE A H
R279(1)	DX06 A1	60a	DX06 DATA TO MEN DISABLE B H
R237(1)	DX06 A1	60a	DX06 DATA TO MEN DISABLE C H
R186(1)	DX06 B1	60a	DX06 DATA TO MEN DISABLE D H
R262(1)	DX06 B1	60a	DX06 DATA TO MEN DISABLE E H
R196(1)	DX06 A1	60a	DX06 DATA TO MEN DISABLE F H
R290(1)	DX06 C2	60a	DX06 SBUS0 [N/10+1, DATA PAR IN, SPARE] H
R291(1)	DX06 C2	60a	DX06 SBUS1 [N/10+1, DATA PAR IN, SPARE] H
R97(1)	DX02 C7	60a	MB [N+00] H
R263(1)	DX02 C3	60a	MB [N+01] H
R284(1)	DX02 B5	60a	MB [N+02] H
R96(1)	DX02 C5	60a	MB [N+03] H
R281(1)	DX02 B7	60a	MB [N+04] H
R72(1)	DX02 B3	60a	MB [N+05] H
R73(1)	DX03 C7	60a	MB [N+06] H
R45(1)	DX03 C3	60a	MB [N+07] H
R280(1)	DX03 B5	60a	MB [N+08] H
R236(1)	DX03 C5	60a	MB [N+09] H
R46(1)	DX03 B7	60a	MB [N+10] H

RESISTOR LOC(PIN)	SHOWN ON DRUM REF	VALUE	TERMINATES SIGNAL
R278(1)	DX03 B3	60a	MB [N+11] H
R283(1)	DX04 C7	60a	MB [N+12] H
R188(1)	DX04 C3	60a	MB [N+13] H
R187(1)	DX04 B5	60a	MB [N+14] H
R275(1)	DX04 C5	60a	MB [N+15] H
R172(1)	DX04 B7	60a	MB [N+16] H
R173(1)	DX04 B3	60a	MB [N+17] H
R183(1)	DX01 C3	60a	MEM R0 [N/10+1,0,3] H
R276(1)	DX06 B2	60a	MEM T111
R289(1)	DX06 B2	60a	MEM T113
R300(1)	DX01 C3	60a	MEM [N/10+1, R0 1, R0 R0] H
R299(1)	DX01 B3	60a	MEM [N/10+1, R0 2, R0 R0] H
R161(1)	DX01 D3	60a	MEM [N/10+1, START A, START B] H
R91(1)	DX05 D3	60a	MEM [P/12+1, SPARE 33, SPARE 32] H
R176(1)	DX05 D8	60a	PMA [P+14] H
R177(1)	DX05 D8	60a	PMA [P+15] H
R175(1)	DX05 D8	60a	PMA [P+16] H
R174(1)	DX05 D8	60a	PMA [P+17] H
R289(1)	DX05 D6	60a	PMA [P+18] H
R288(1)	DX05 D6	60a	PMA [P+19] H
R211(1)	DX05 D6	60a	PMA [P+20] H
R210(1)	DX05 C6	60a	PMA [P+21] H
R293(1)	DX05 C8	60a	[N+1, SBUS ADR HOLD H, MEN TERM 10]
R160(1)	DX01 B7	60a	[N/10+1, CLK SBUS, SPARE] CLK H
R199(1)	DX06 C3	60a	[N/10+1, MB PAR, SPARE 7] H
R277(1)	DX06 B2	60a	[N/10+1, MB23 SEQ R0, MEN DATA TO MEN] H
R182(1)	DX01 A3	60a	[N/10+1, MEN DIAG, -MEN ADR PAR] H
R294(1)	DX06 D7	60a	[N/10+1, MEN SPARE, DIAG MEN RESET] H
R88(1)	DX05 D3	60a	[P/12+1, PMA 22, SBUS ADR 34] H
R89(1)	DX05 D3	60a	[P/12+1, PMA 23, SBUS ADR 35] H
R90(1)	DX05 D3	60a	[P/12+1, PMA 24, PMA 25] H

- NOTE:
- ALL TERMINATORS HAVE PIN TWO CONNECTED TO -2.0V AND ARE 5% 1/4WATT UNLESS OTHERWISE SPECIFIED
  - ENTRIES ARE SORTED BY SIGNAL NAME
  - X INDICATES OUTPUT OF DIP LOC AND ( ) INDICATES PIN NUMBER

REV. 1  
SIZE CODE CS M8581-0-RES  
D

PARTS DRAWING AND SPECIFICATIONS HEREIN ARE THE PROPERTY OF DIGITAL EQUIPMENT CORPORATION AND SHALL NOT BE REPRODUCED OR COPIED OR USED IN WHOLE OR IN PART AS THE BASIS FOR THE MANUFACTURE OR SALE OF ITEMS WITHOUT WRITTEN PERMISSION. COPYRIGHT © 1976, DIGITAL EQUIPMENT CORPORATION.	REVISIONS			DRN. <i>C. Smith</i>	DATE <i>10-20-76</i>	ENG. <i>D. ...</i>	DATE <i>10-20-76</i>	TITLE: <b>TERMINATORS</b>
	CHK	CHANGE NO.		REV.	BOARD LOCATION:	SHEET <i>1</i> OF <i>1</i>	NEXT HIGHER ASSEMBLY:	SIZE CODE
				FIRST USED ON OPTION/MODEL: <i>MF20</i>	<i>D-DD-M8581-0</i>			<i>D CS M8581-0-RES</i>

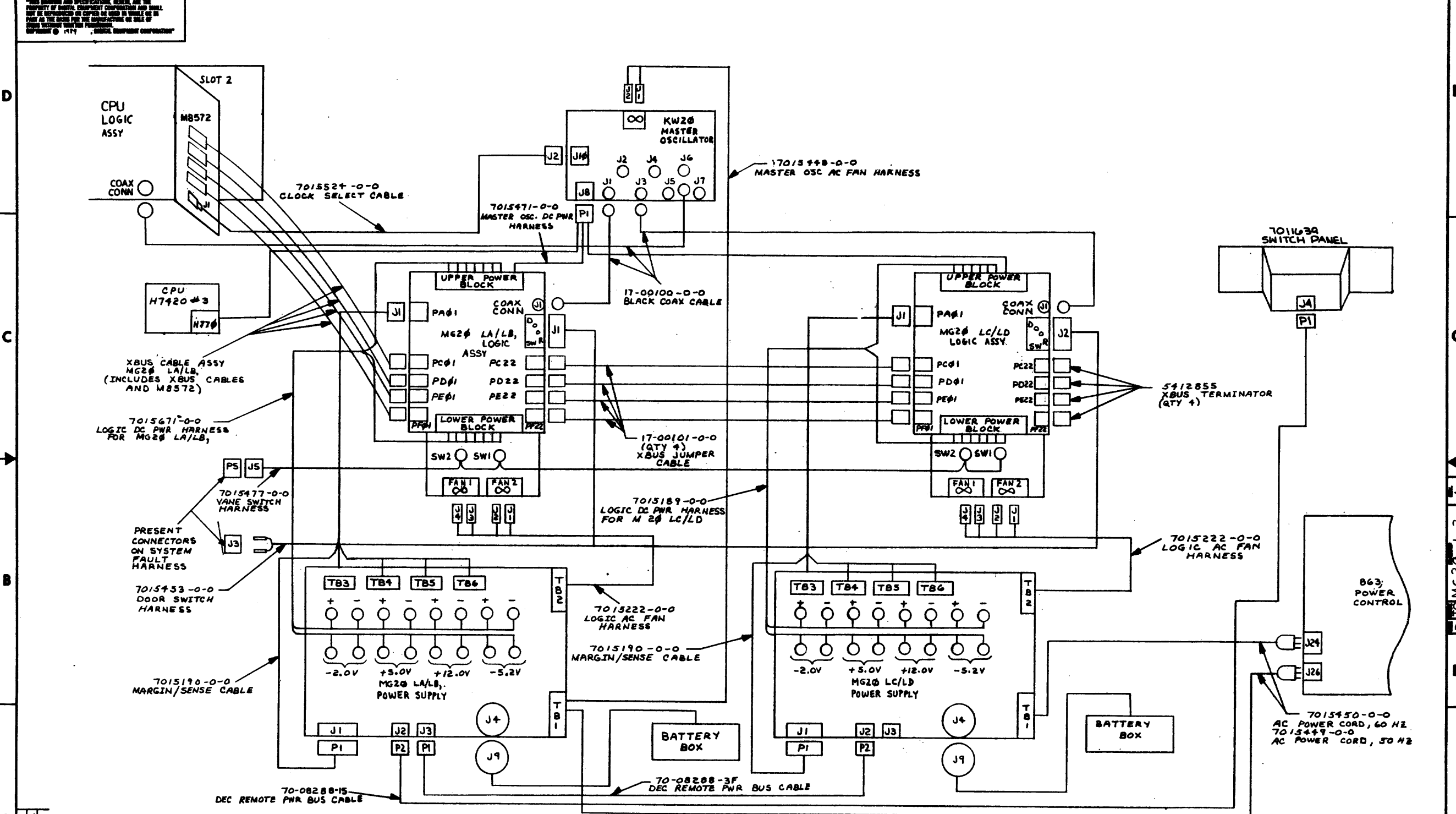

REV. 1  
 CHANGE NO. 1  
 RELEASED 1A

DRAWN: <i>[Signature]</i>	FIRST USED ON: MG20-L-10-00-01
CHECKED: <i>[Signature]</i>	TITLE: MG20-L
ENGR: <i>[Signature]</i>	CABLE DIAGRAM
PROD. ENGR: <i>[Signature]</i>	
PROD. <i>[Signature]</i>	
NEXT HIGHER ASSY:	
B-DD-MG20-L	SIZE CODE: NUMBER
SCALE: NONE	D I C MG20-L-2 A
SHEET: 1	OF: 1

MG20 "GROUP" 00

FIELD 0 ( BITS )	FIELD 1 ( BITS )	FIELD 2 ( BITS )	FIELD 3 ( BITS )
00,02,04,06 08,10,12,14 16,36,38	01,03,05,07 09,11,13,15 17,37,39	18,20,22,24 26,28,30,32 34,40,42	19,21,23,25 27,29,31,33 35,41,43
SUB-BLOCK 0	SUB-BLOCK 0	SUB-BLOCK 0	SUB-BLOCK 0
SUB-BLOCK 1	SUB-BLOCK 1	SUB-BLOCK 1	SUB-BLOCK 1
SUB-BLOCK 2	SUB-BLOCK 2	SUB-BLOCK 2	SUB-BLOCK 2
SUB-BLOCK 3	SUB-BLOCK 3	SUB-BLOCK 3	SUB-BLOCK 3

-- BLOCK 0  
0-256K

SUB-BLOCK 0	SUB-BLOCK 0	SUB-BLOCK 0	SUB-BLOCK 0
SUB-BLOCK 1	SUB-BLOCK 1	SUB-BLOCK 1	SUB-BLOCK 1
SUB-BLOCK 2	SUB-BLOCK 2	SUB-BLOCK 2	SUB-BLOCK 2
SUB-BLOCK 3	SUB-BLOCK 3	SUB-BLOCK 3	SUB-BLOCK 3

-- BLOCK 1  
256K-512K

SUB-BLOCK 0	SUB-BLOCK 0	SUB-BLOCK 0	SUB-BLOCK 0
SUB-BLOCK 1	SUB-BLOCK 1	SUB-BLOCK 1	SUB-BLOCK 1
SUB-BLOCK 2	SUB-BLOCK 2	SUB-BLOCK 2	SUB-BLOCK 2
SUB-BLOCK 3	SUB-BLOCK 3	SUB-BLOCK 3	SUB-BLOCK 3

-- BLOCK 2  
512K-768K

SUB-BLOCK 0	SUB-BLOCK 0	SUB-BLOCK 0	SUB-BLOCK 0
SUB-BLOCK 1	SUB-BLOCK 1	SUB-BLOCK 1	SUB-BLOCK 1
SUB-BLOCK 2	SUB-BLOCK 2	SUB-BLOCK 2	SUB-BLOCK 2
SUB-BLOCK 3	SUB-BLOCK 3	SUB-BLOCK 3	SUB-BLOCK 3

-- BLOCK 3  
768K-1024K

1. ALL BLOCK SIZES SHOWN ARE FOR 64K CHIP ONLY
2. GROUPS SHOWN REFLECT MG20 CONFIGURATIONS

MG20 "GROUP" 01

FIELD 0 ( BITS )	FIELD 1 ( BITS )	FIELD 2 ( BITS )	FIELD 3 ( BITS )
00,02,04,06 08,10,12,14 16,36,38	01,03,05,07 09,11,13,15 17,37,39	18,20,22,24 26,28,30,32 34,40,42	19,21,23,25 27,29,31,33 35,41,43
SUB-BLOCK 0	SUB-BLOCK 0	SUB-BLOCK 0	SUB-BLOCK 0
SUB-BLOCK 1	SUB-BLOCK 1	SUB-BLOCK 1	SUB-BLOCK 1
SUB-BLOCK 2	SUB-BLOCK 2	SUB-BLOCK 2	SUB-BLOCK 2
SUB-BLOCK 3	SUB-BLOCK 3	SUB-BLOCK 3	SUB-BLOCK 3

-- BLOCK 4  
1024K-1280K

SUB-BLOCK 0	SUB-BLOCK 0	SUB-BLOCK 0	SUB-BLOCK 0
SUB-BLOCK 1	SUB-BLOCK 1	SUB-BLOCK 1	SUB-BLOCK 1
SUB-BLOCK 2	SUB-BLOCK 2	SUB-BLOCK 2	SUB-BLOCK 2
SUB-BLOCK 3	SUB-BLOCK 3	SUB-BLOCK 3	SUB-BLOCK 3

-- BLOCK 5  
1280K-1536K

SUB-BLOCK 0	SUB-BLOCK 0	SUB-BLOCK 0	SUB-BLOCK 0
SUB-BLOCK 1	SUB-BLOCK 1	SUB-BLOCK 1	SUB-BLOCK 1
SUB-BLOCK 2	SUB-BLOCK 2	SUB-BLOCK 2	SUB-BLOCK 2
SUB-BLOCK 3	SUB-BLOCK 3	SUB-BLOCK 3	SUB-BLOCK 3

-- BLOCK 6  
1536K-1792K

SUB-BLOCK 0	SUB-BLOCK 0	SUB-BLOCK 0	SUB-BLOCK 0
SUB-BLOCK 1	SUB-BLOCK 1	SUB-BLOCK 1	SUB-BLOCK 1
SUB-BLOCK 2	SUB-BLOCK 2	SUB-BLOCK 2	SUB-BLOCK 2
SUB-BLOCK 3	SUB-BLOCK 3	SUB-BLOCK 3	SUB-BLOCK 3

-- BLOCK 7  
1792K-2048K

THIS DRAWING AND SPECIFICATIONS  
HEREIN ARE THE PROPERTY OF  
DIGITAL EQUIPMENT CORPORATION AND  
SHALL NOT BE REPRODUCED OR COPIED  
OR USED IN WHOLE OR IN PART AS  
THE BASIS FOR THE MANUFACTURE  
OR SALE OF ITEMS WITHOUT WRITTEN  
PERMISSION. COPYRIGHT © 1984,  
DIGITAL EQUIPMENT CORPORATION.

REVISIONS		
CHK	CHANGE NO.	REV
RELEASED	A	

digital	DRN.	DATE	ENG.	DATE	TITLE:
	R CARN	20-JUN-84	RJ EICHMANN	20-JUN-84	STORAGE ARRAY ORGANIZATION
	CHK'D	DATE	BOARD LOCATION:		
	G FLANDERS	20-JUN-84	SHEET 1 OF 1		
XTRA: EICHMANN 8520GR.DRW 119-JUN-84 11:52 NEXT HIGHER ASSEMBLY:					SIZE CODE
FIRST USED ON OPTION/MODEL: MG20					D BD
					NUMBER
					MG20-0-1
					REV.
					A

REV. A  
NUMBER  
MG20-0-1  
SIZE CODE D BD

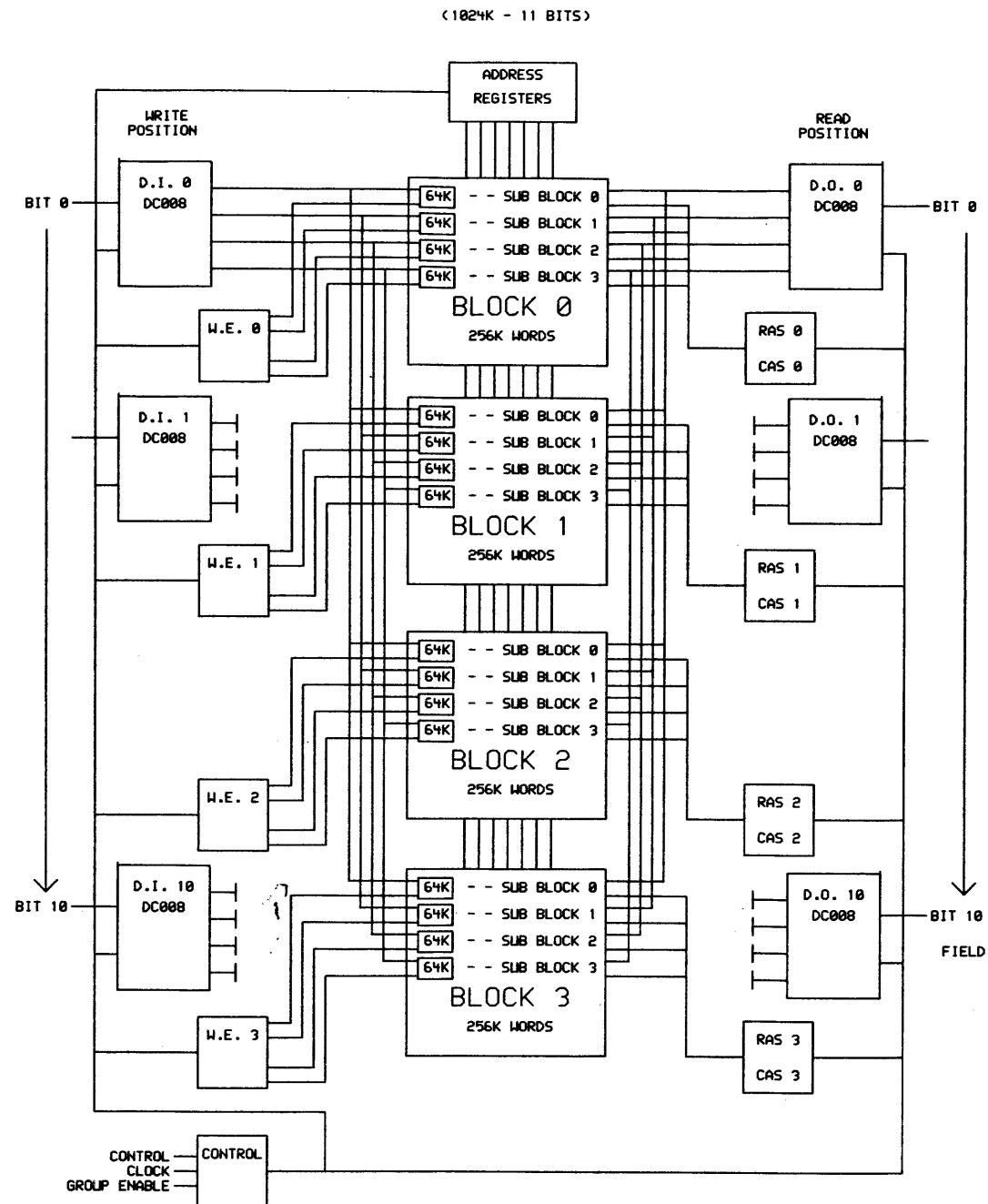

REV. A  
NUMBER MG20-0-3  
SIZE CODE BD  
B  
A

THIS DRAWING AND SPECIFICATIONS  
HEREIN ARE THE PROPERTY OF  
DIGITAL EQUIPMENT CORPORATION AND  
SHALL NOT BE REPRODUCED OR COPIED  
OR USED IN WHOLE OR IN PART AS  
THE BASIS FOR THE MANUFACTURE OR  
SALE OF ITEMS WITHOUT WRITTEN  
PERMISSION. COPYRIGHT © 1984  
DIGITAL EQUIPMENT CORPORATION

REVISIONS	
CHK	CHANGE NO. REV
RELEASED	A

DRN.	R CARM	DATE	20-JUN-84	ENG.	RJ EICHMANN	DATE	20-JUN-84	TITLE:	MG20M
CHK'D	G FLANDERS	DATE	20-JUN-84	BOARD LOCATION:					BLOCK DIAGRAM
XTRA: <EICHMANN>R570FL.DRW		120-JUN-84 15145		NEXT HIGHER ASSEMBLY:		SIZE	CODE	NUMBER	REV.
FIRST USED ON OPTION/MODEL:		MG20		MG20-0		D	BD	MG20-0-3	A

digital	DRN.	R CARM	DATE	20-JUN-84	ENG.	RJ EICHMANN	DATE	20-JUN-84	TITLE:	MG20M
	CHK'D	G FLANDERS	DATE	20-JUN-84	BOARD LOCATION:					BLOCK DIAGRAM
	XTRA: <EICHMANN>R570FL.DRW		120-JUN-84 15145		NEXT HIGHER ASSEMBLY:		SIZE	CODE	NUMBER	REV.
	FIRST USED ON OPTION/MODEL:		MG20		MG20-0		D	BD	MG20-0-3	A

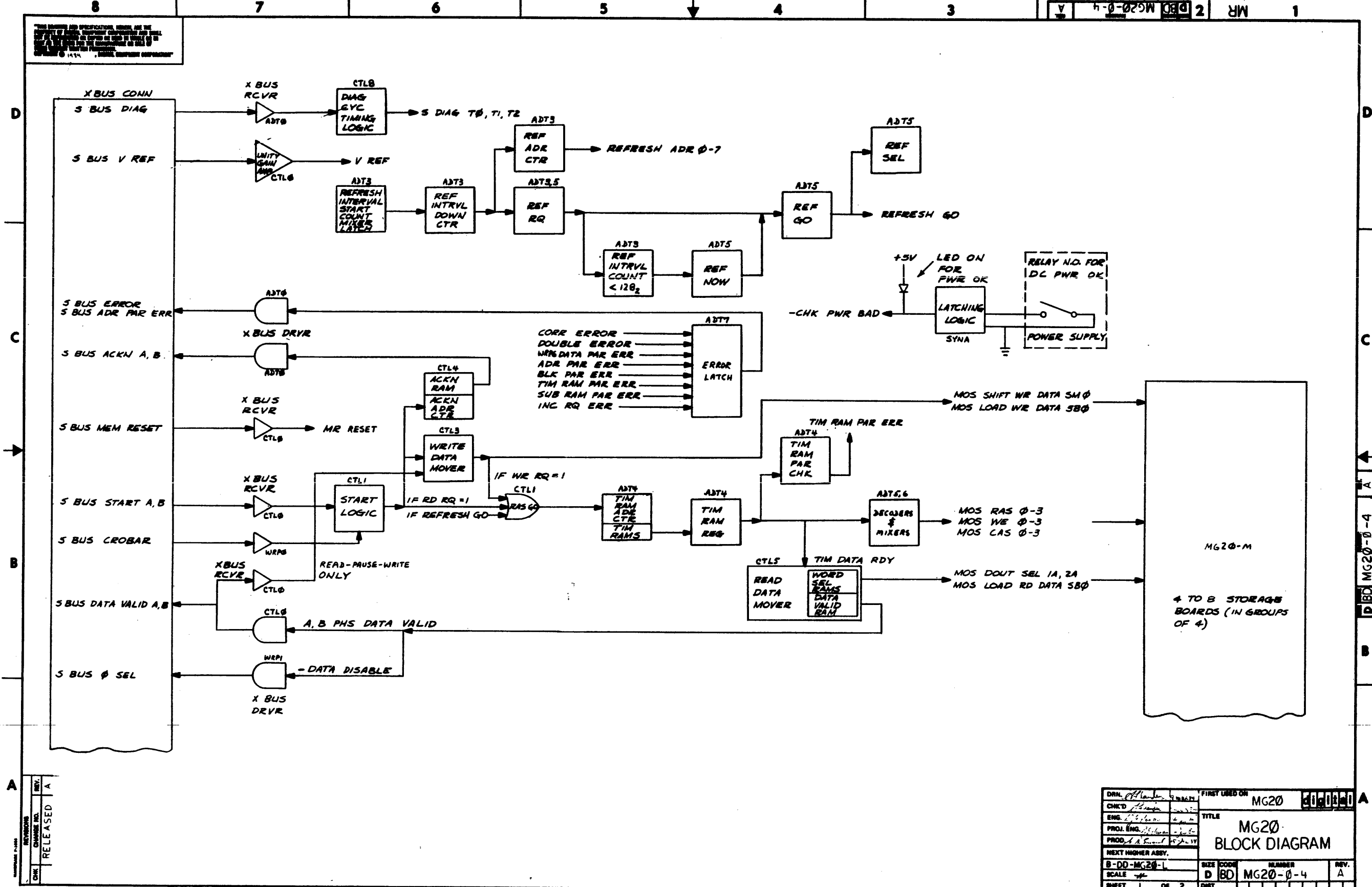

REV. A  
RELEASED

DRN. <i>[Signature]</i>	FIRST USED ON	MG20
CHK'D <i>[Signature]</i>	TITLE	MG20 BLOCK DIAGRAM
ENG. <i>[Signature]</i>	SIZE CODE	D BD
PROJ. ENG. <i>[Signature]</i>	NUMBER	MG20-0-4
PROD. <i>[Signature]</i>	REV.	A
NEXT HIGHER ASSY.	SCALE	
B-DD-MG20-1	SHEET	1 OF 2

"THIS DRAWING AND SPECIFICATIONS, HEREIN, ARE THE PROPERTY OF DIGITAL EQUIPMENT CORPORATION AND SHALL NOT BE REPRODUCED OR COPIED OR USED IN WHOLE OR IN PART AS THE BASIS FOR THE MANUFACTURE OR SALE OF ITEMS WITHOUT WRITTEN PERMISSION. COPYRIGHT © 1974 DIGITAL EQUIPMENT CORPORATION"

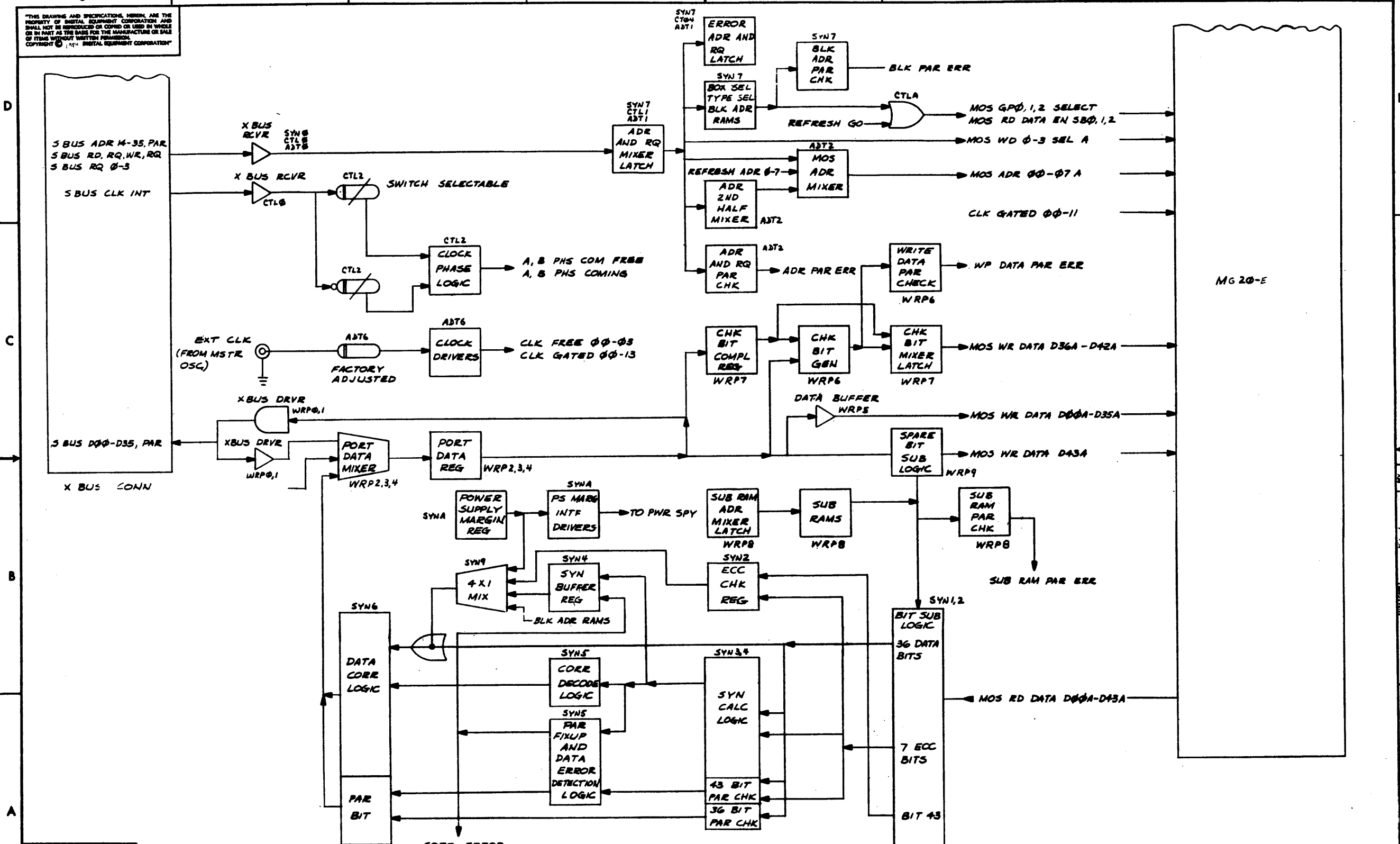

REVISIONS		
CHK	CHANGE NO.	REV.

THIS DRAWING AND SPECIFICATIONS HEREIN ARE THE PROPERTY OF MICHAEL BAKER CORPORATION AND SHALL NOT BE REPRODUCED OR COPIED IN WHOLE OR IN PART IN ANY MANNER FOR THE MANUFACTURE OR SALE OF ANY EQUIPMENT WITHOUT WRITTEN PERMISSION OF MICHAEL BAKER CORPORATION © 1974

MR 2 DTD MG20-0-5

TIM RAM ADDRESS

REPEAT FOR 166 → 177 →

RAMS CONTENTS

		0	1	2	3	4	5	6	7	8	9	10	11	12	13	14	15	16	17	18	19	20	21	→ 177	
RAS	D00	1	1	1	1	1	1	1	1	0	0	0	0	0	0	0	0	0	0	0	0	0	0	→	0
CAS	D01	0	0	0	1	1	1	1	1	0	0	0	0	0	0	0	0	0	0	0	0	0	0	→	0
PARITY	D02	0	0	0	1	1	1	0	1	1	1	1	1	1	1	1	1	0	1	0	0	0	→	0	0
WE(L)	D03	1	0	0	0	0	0	0	0	1	1	1	1	1	1	1	1	1	1	1	1	1	→	1	1
2NDHALF	D04	0	1	1	1	1	1	1	1	0	0	0	0	0	0	0	0	0	0	0	0	0	→	0	0
DATA RDY	D05	1	1	1	1	1	1	0	1	1	1	1	1	1	1	1	1	1	1	1	1	1	→	1	1
BUSY CLR	D06	0	0	0	0	0	0	0	0	0	0	0	0	0	0	0	0	1	0	0	0	0	→	0	0

REV. 1  
 CHANGE NO. 1  
 RELEASED A

DRN. <i>[Signature]</i>	DATE <i>[Date]</i>	PROJECT NO. MG20	REV. 0000
CHK'D <i>[Signature]</i>	DATE <i>[Date]</i>	TITLE MG20	
ENG. <i>[Signature]</i>		TIMING RAMS	
PROD. ENG. <i>[Signature]</i>			
PROD. <i>[Signature]</i>			
NEXT NUMBER ASSY.			
B-DO-MG20-1	SIZE CODE	NUMBER	REV. A
SCALE NONE	D TD	MG20-0-5	
SHEET 1 OF 1	DIST.		

2 MR 1

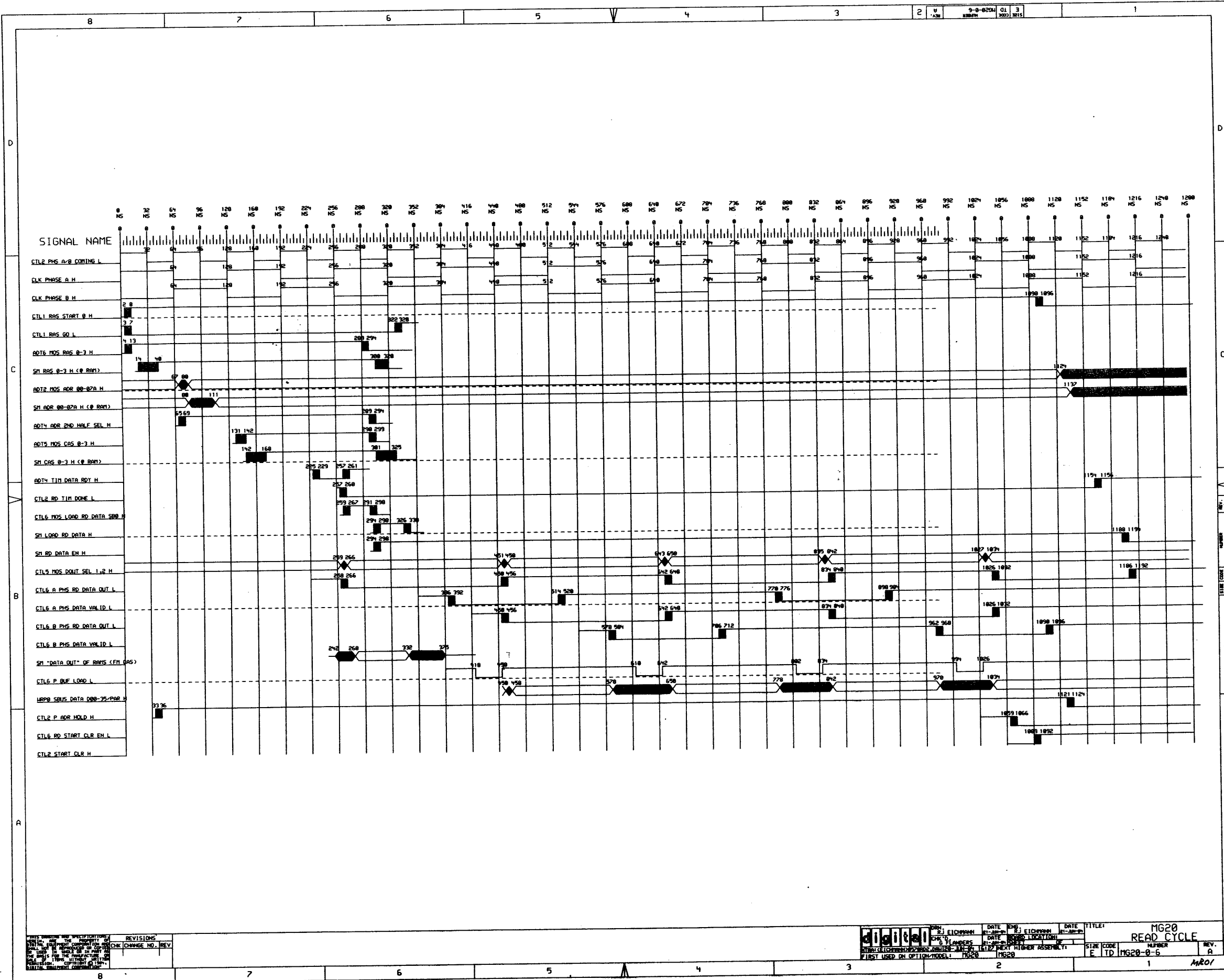

REV	CHG	NO.	REV

DATE: 10/1/82  
TITLE: MG20 READ CYCLE  
REV: A  
E I T D ING20-0-5  
MRO1

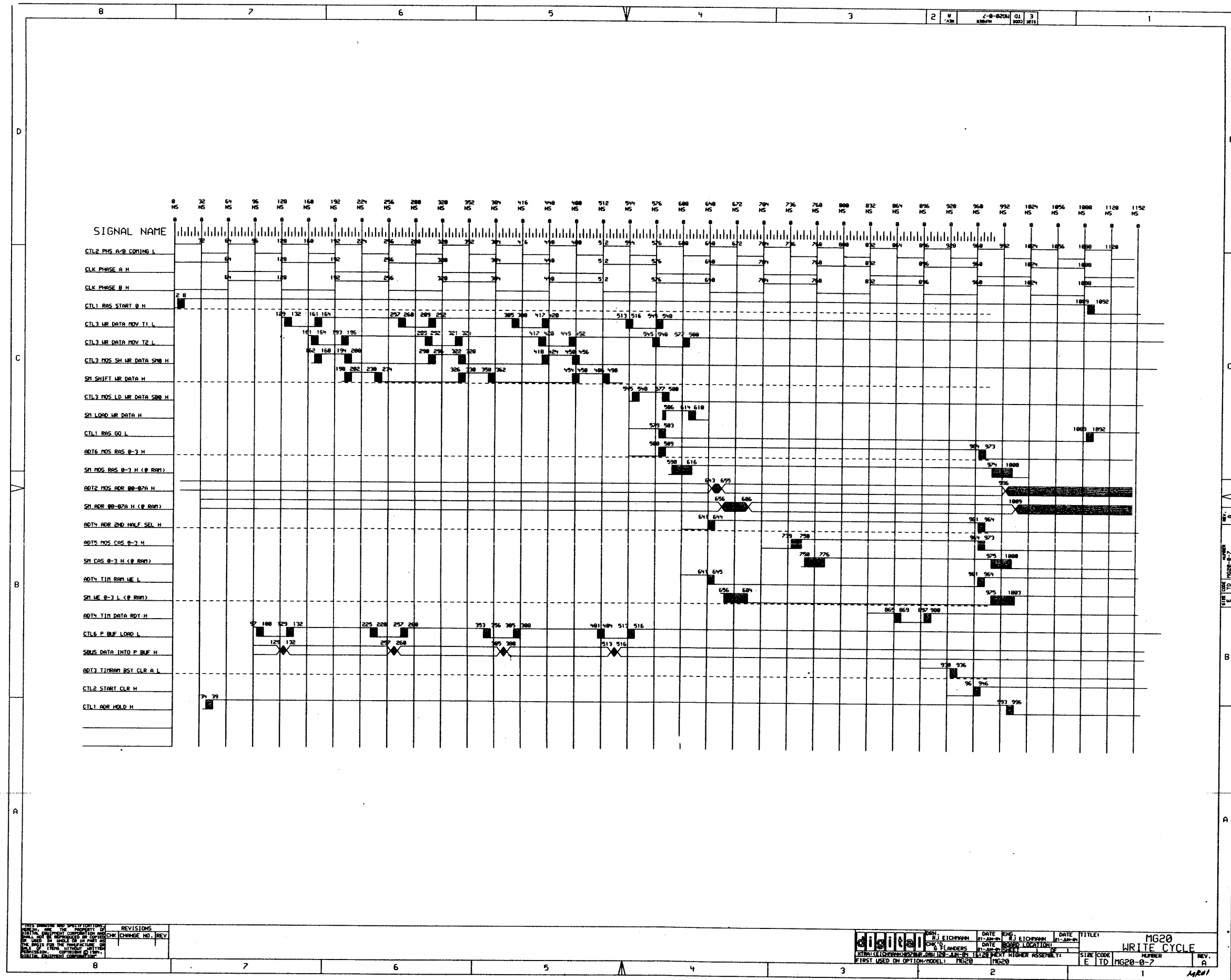

REVISIONS
CHANGE NO. REV

**digital** DATA CENTER

DATE: 10/1/84  
 DATE: 10/1/84  
 DATE: 10/1/84

TITLE: MG20 WRITE CYCLE

SIZE CODE: E  
 NUMBER: 1  
 REV: A

DATE: 10/1/84  
 TIME: 10:00 AM  
 BY: J. E. H. 10/1/84  
 REV. A

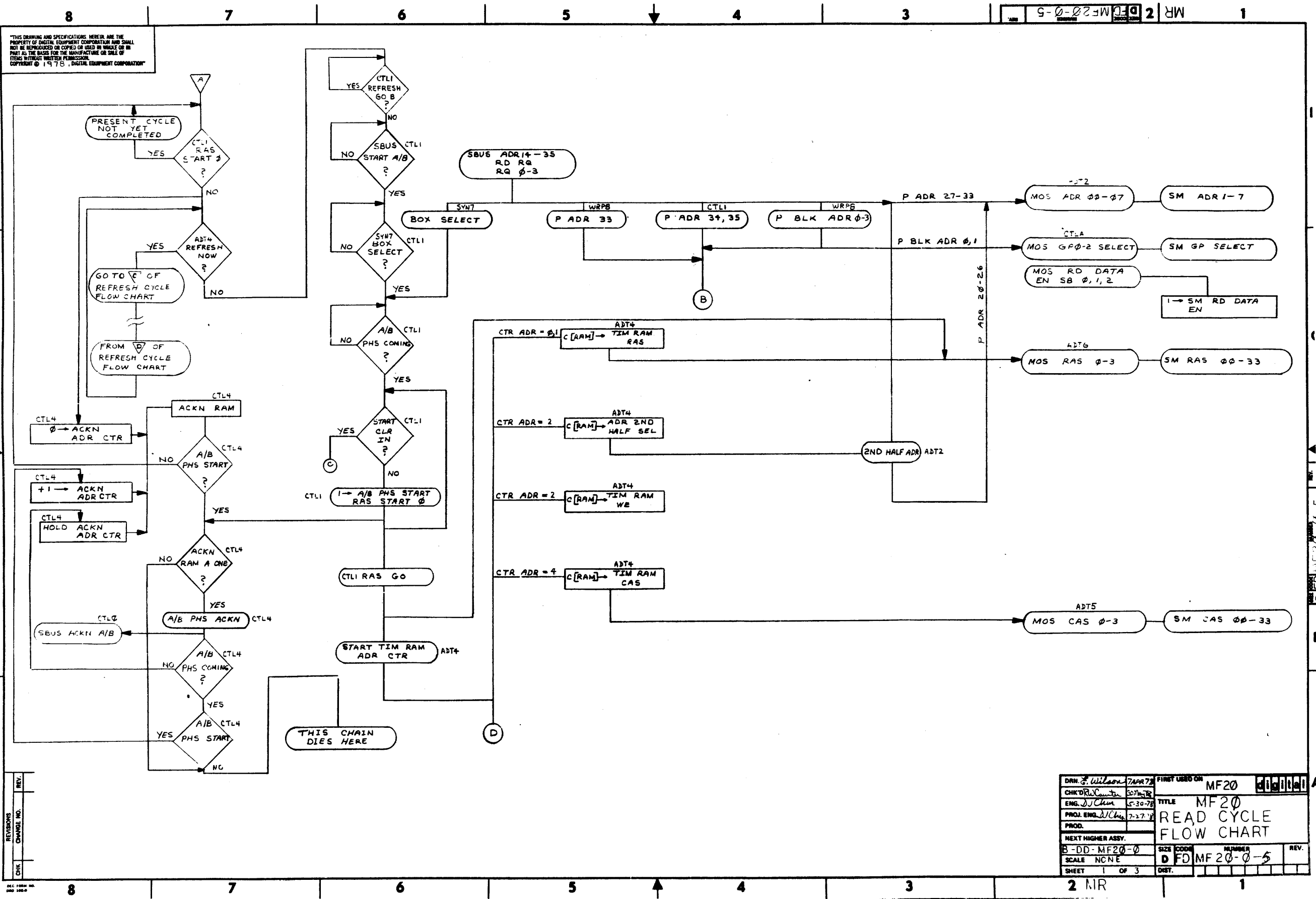

"THIS DRAWING AND SPECIFICATIONS HEREIN ARE THE PROPERTY OF DIGITAL EQUIPMENT CORPORATION AND SHALL NOT BE REPRODUCED OR COPIED OR USED IN WHOLE OR IN PART AS THE BASIS FOR THE MANUFACTURE OR SALE OF ITEMS WITHOUT WRITTEN PERMISSION. COPYRIGHT © 1978, DIGITAL EQUIPMENT CORPORATION"

DRN. J. Wilson	7/27/78	FIRST USED ON	MF20
CHK'D R. Cantor	8/14/78	TITLE	MF20 READ CYCLE FLOW CHART
ENG. J. Chen	5-30-78	SIZE CODE	D
PROJ. ENG. W. Chy	7-27-78	NUMBER	MF20-0-5
PROD.		REV.	
NEXT HIGHER ASSY.		SHEET	1 OF 3
B-DD-MF20-0		DIST.	
SCALE NONE			

"THIS DRAWING AND SPECIFICATIONS HEREIN ARE THE PROPERTY OF DIGITAL EQUIPMENT CORPORATION AND SHALL NOT BE REPRODUCED OR COPIED OR USED IN WHOLE OR IN PART AS THE BASIS FOR THE MANUFACTURE OR SALE OF ITEMS WITHOUT WRITTEN PERMISSION. COPYRIGHT © 1978 DIGITAL EQUIPMENT CORPORATION"

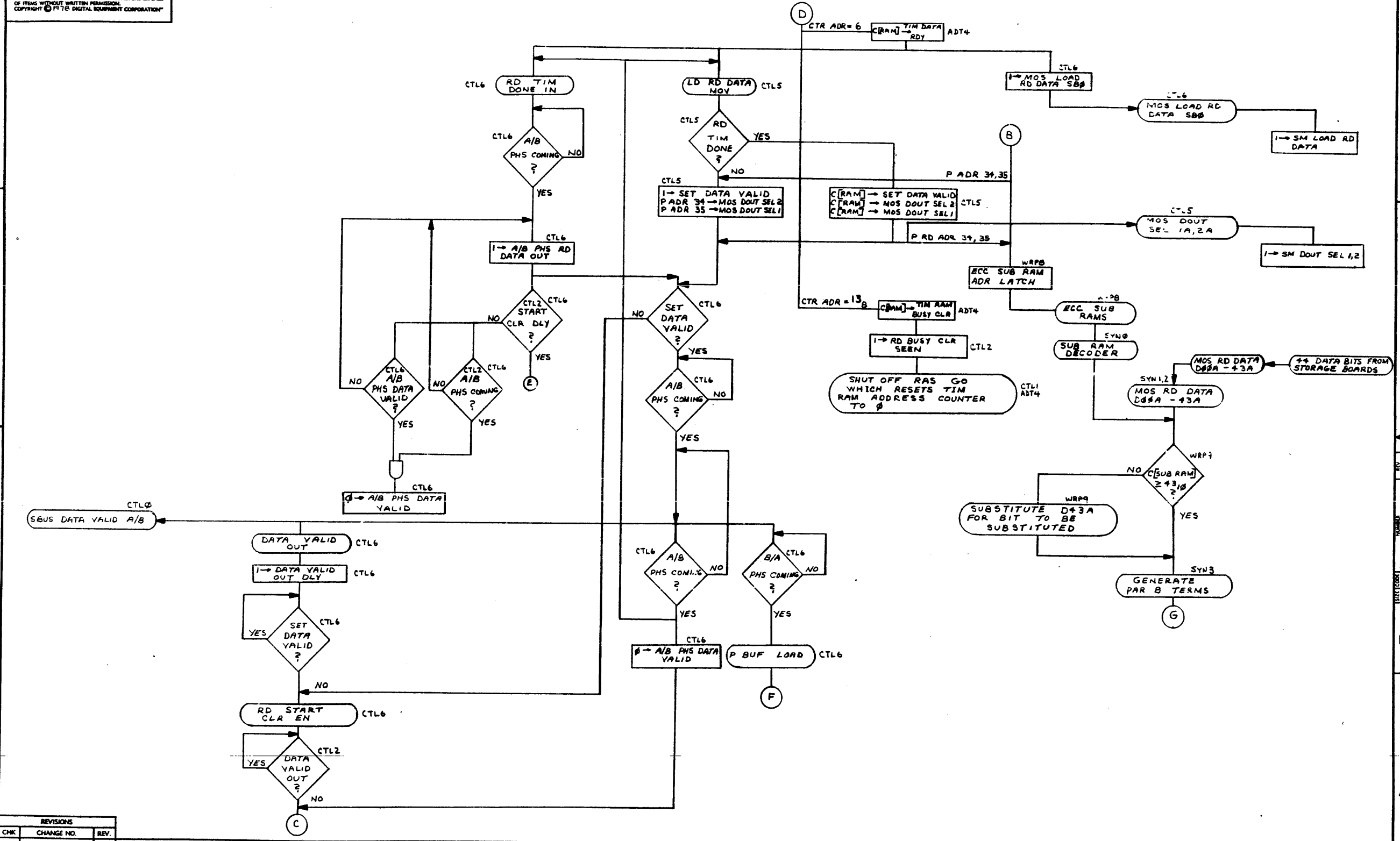

REVISIONS		
CHK	CHANGE NO.	REV.

THIS DRAWING AND SPECIFICATIONS HEREIN ARE THE PROPERTY OF DIGITAL EQUIPMENT CORPORATION AND SHALL NOT BE REPRODUCED OR COPIED OR USED IN WHOLE OR IN PART AS THE BASIS FOR THE MANUFACTURE OR SALE OF ITEMS WITHOUT WRITTEN PERMISSION. COPYRIGHT © 1978 DIGITAL EQUIPMENT CORPORATION

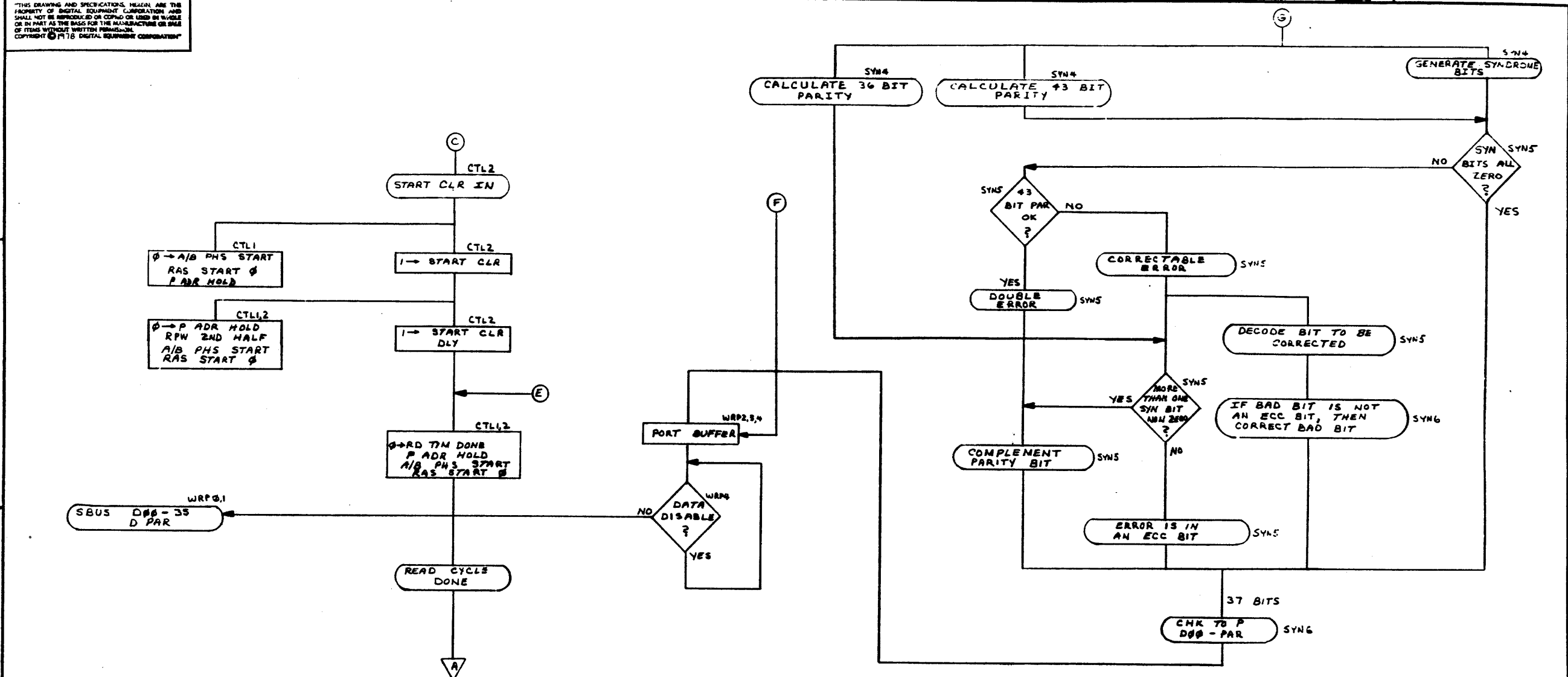

REVISIONS		
CHK	CHANGE NO.	REV.

"THIS DRAWING AND SPECIFICATIONS HEREIN ARE THE PROPERTY OF DIGITAL EQUIPMENT CORPORATION AND SHALL NOT BE REPRODUCED OR COPIED OR USED IN WHOLE OR IN PART AS THE BASIS FOR THE MANUFACTURE OR SALE OF ITEMS WITHOUT WRITTEN PERMISSION.  
 COPYRIGHT © 1978, DIGITAL EQUIPMENT CORPORATION"

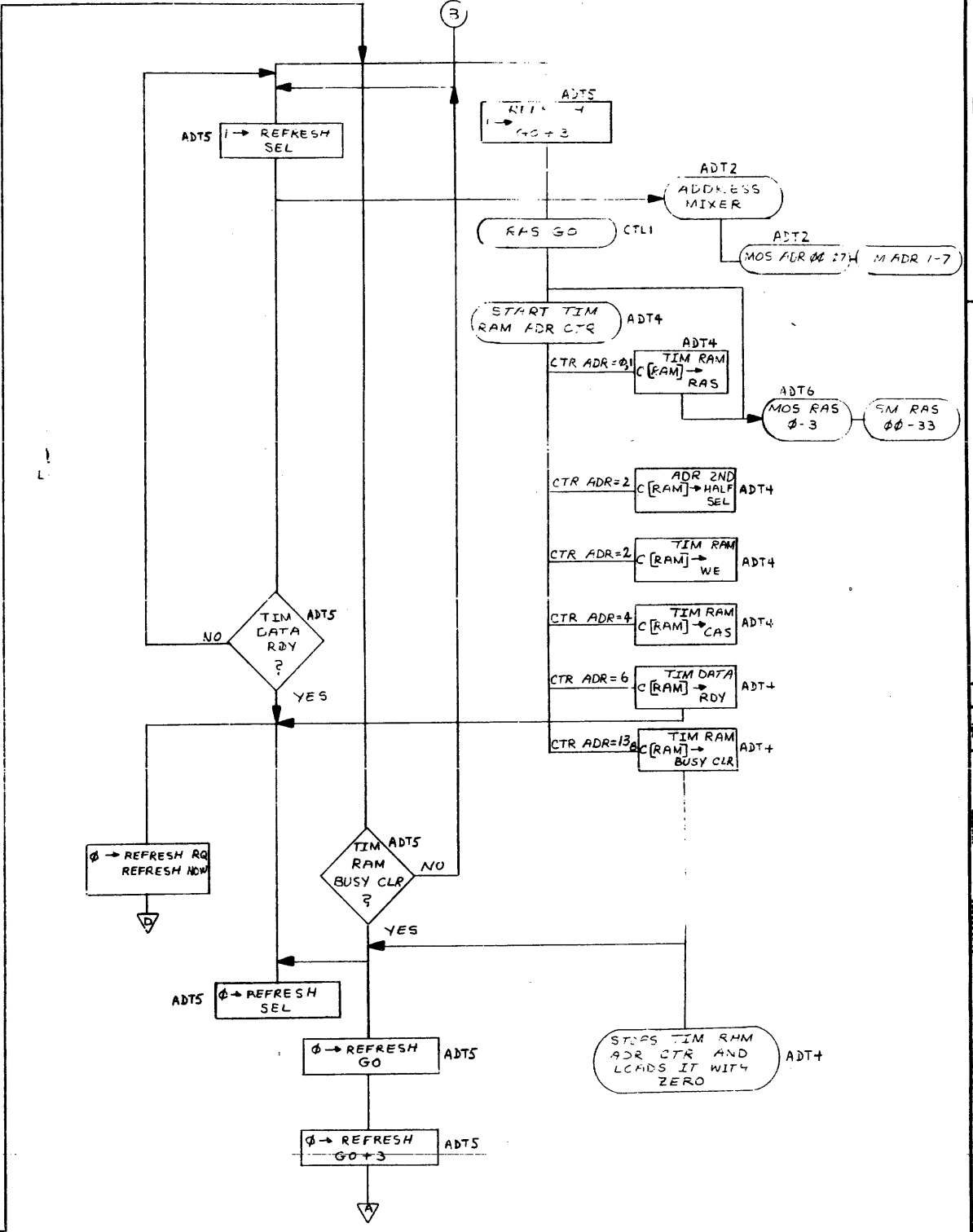
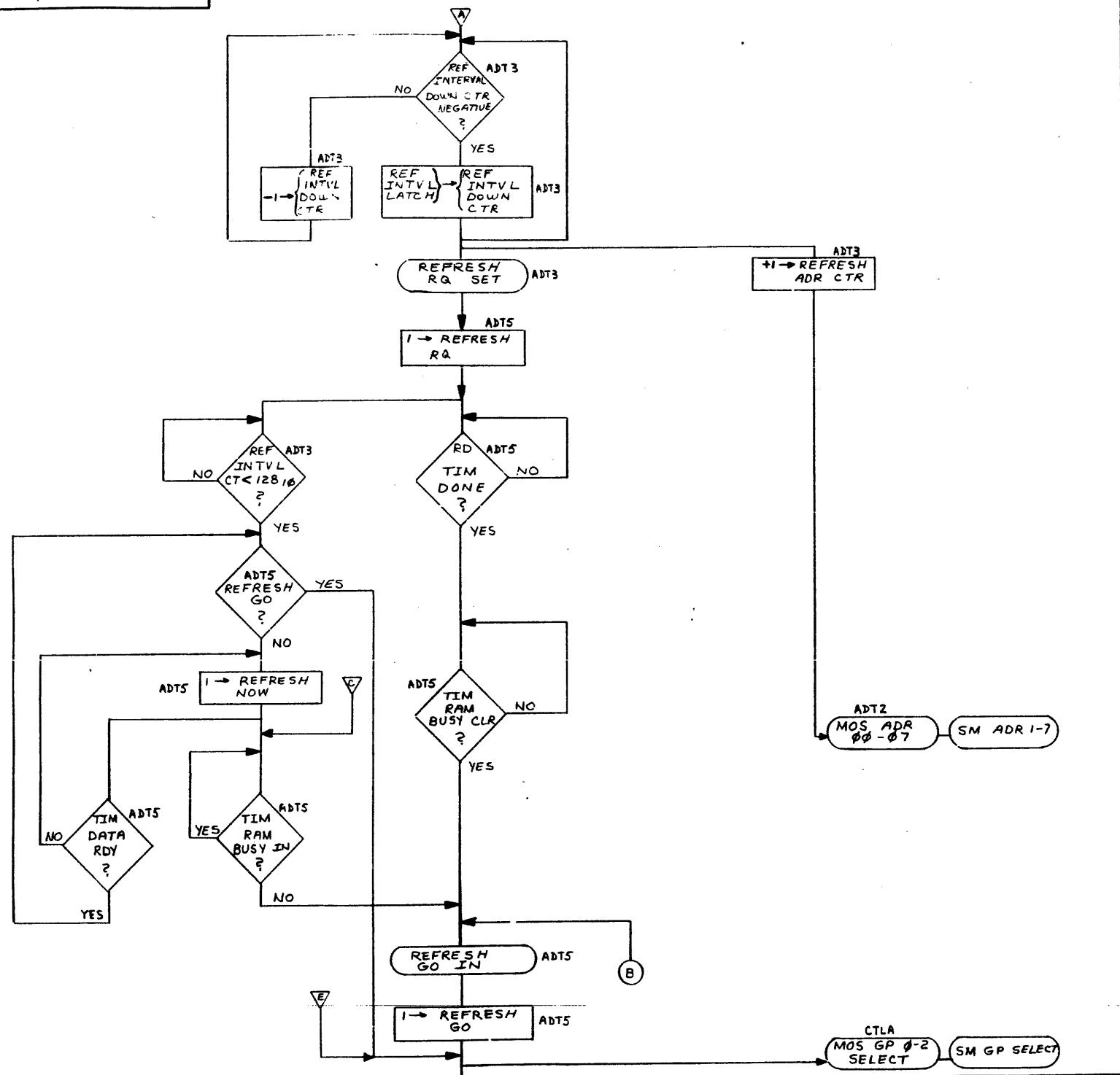

DRN: <i>W. C. ...</i>	FIRST USED ON: MF20
CHK'D: <i>W. C. ...</i>	TITLE: MF20
ENG: <i>W. C. ...</i>	REFRESH CYCLE
PROJ. ENG: <i>W. C. ...</i>	FLOW CHART
PROD.:	
NEXT HIGHER ASSY.:	
B-DD-MF20-0	SIZE CODE: D
SCALE: NONE	NUMBER: MF20-0-6
SHEET: / OF /	DIST.:

THIS DRAWING AND SPECIFICATIONS HEREAFTER ARE THE PROPERTY OF BUSH BROS. COMPANY AND SHALL NOT BE REPRODUCED OR COPIED IN WHOLE OR IN PART IN ANY MANNER WITHOUT THE WRITTEN PERMISSION OF BUSH BROS. COMPANY.

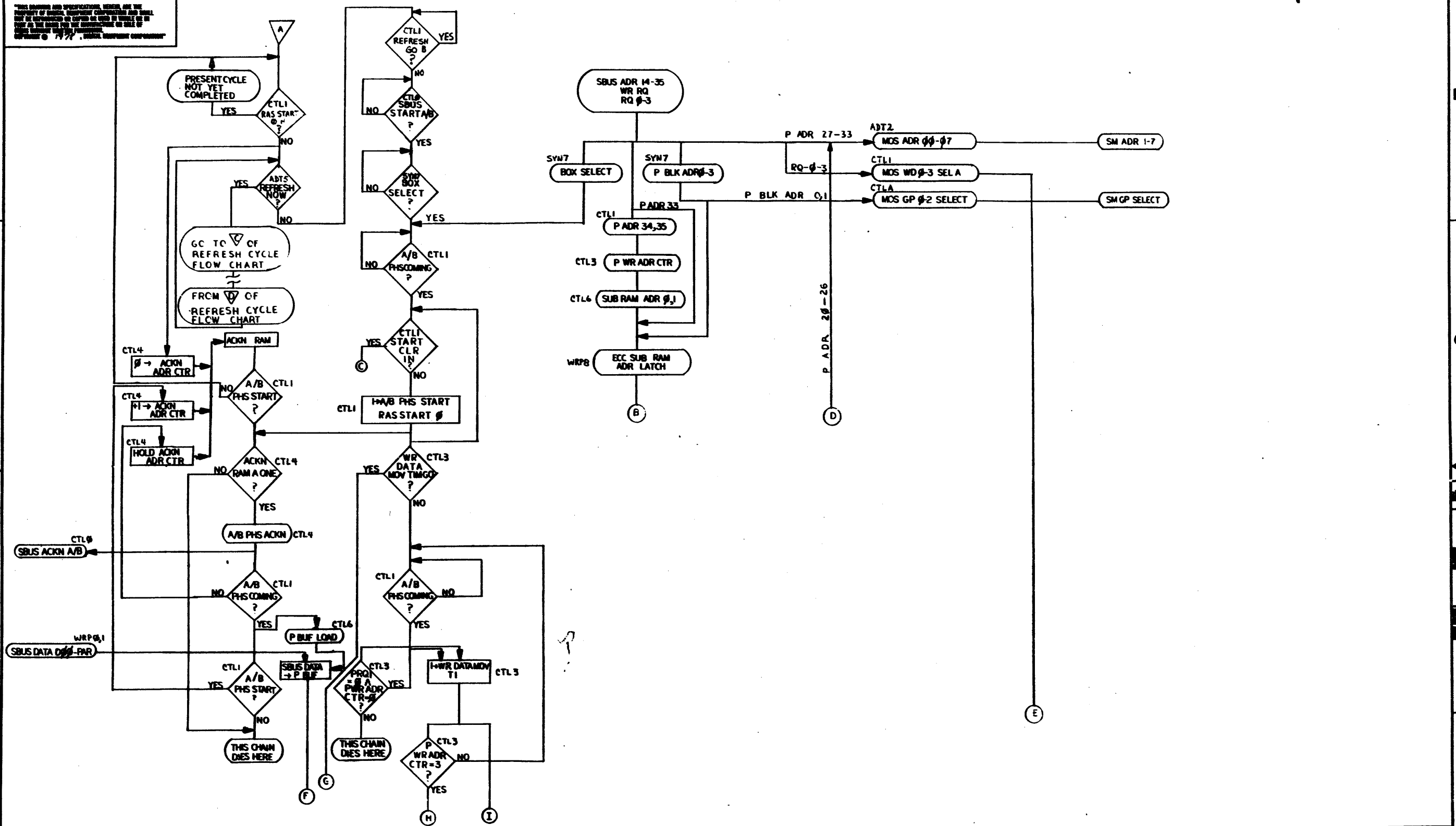

DATE	REV.	PROJ. ENG.	MF20
CHKD BY	DATE	TITLE	MF20
ENGR.	DATE	WRITE CYCLE	FLOW CHART
PROJ. ENG.	DATE	SIZE	D FD
PROJ.	DATE	NUMBER	MF20-0-7
NEXT HIGHER ASSY.	DATE	SCALE	NONE
B-DD-MF20-0	DATE	SHEET	1 OF 3

8  
7  
6  
5  
4  
3  
2  
1

"THE DRAWING AND SPECIFICATIONS HEREIN ARE THE PROPERTY OF DIGITAL EQUIPMENT CORPORATION AND SHALL NOT BE REPRODUCED OR COPIED OR USED IN WHOLE OR IN PART AS THE BASIS FOR THE MANUFACTURE OR SALE OF ITEMS WITHOUT WRITTEN PERMISSION. COPYRIGHT © 1975 DIGITAL EQUIPMENT CORPORATION"

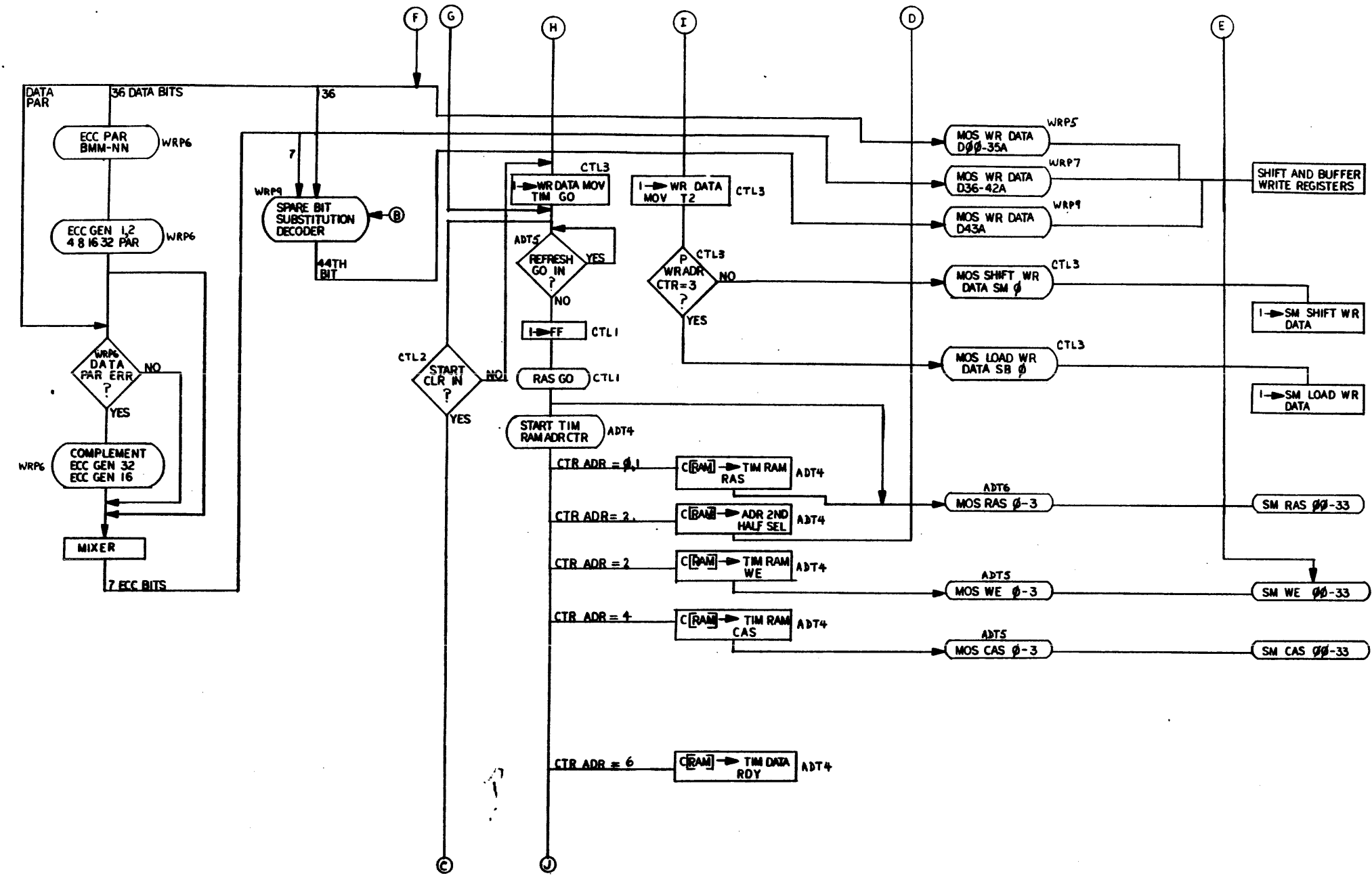

REVISIONS		
CHK	CHANGE NO.	REV.

TITLE	MF20 WRITE CYCLE FLOW CHART	SIZE CODE	D FD	NUMBER	MF20-0-7	REV.	
SCALE	NONE	SHEET	2	OF	3	DATE	

"THIS DRAWING AND SPECIFICATIONS, HEREIN, ARE THE PROPERTY OF DIGITAL EQUIPMENT CORPORATION AND SHALL NOT BE REPRODUCED OR COPIED OR USED IN WHOLE OR IN PART AS THE BASIS FOR THE MANUFACTURE OR SALE OF ITEMS WITHOUT WRITTEN PERMISSION. COPYRIGHT © 1977 DIGITAL EQUIPMENT CORPORATION"

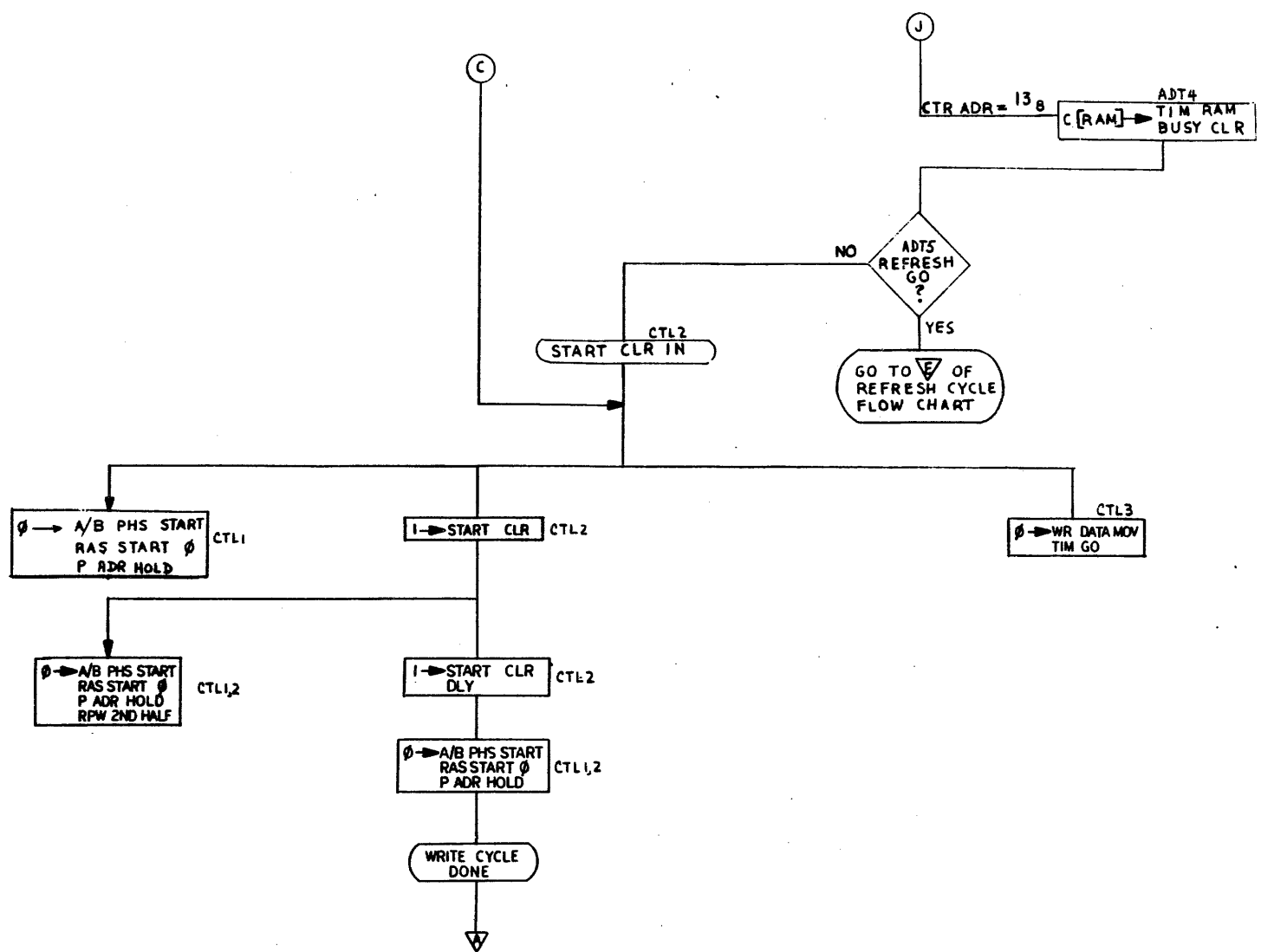

REVISIONS		
CHK	CHANGE NO.	REV.

REV. 1 DFD MF20-0-7

THIS DRAWING AND SPECIFICATIONS HEREIN ARE THE PROPERTY OF ANALOG DEVICES COMPANY AND SHALL NOT BE REPRODUCED OR COPIED IN WHOLE OR IN PART AS THE BASIS FOR THE MANUFACTURE OF ANY DEVICE WITHOUT WRITTEN PERMISSION.  
 COPYRIGHT © 1972, ANALOG DEVICES COMPANY

CTL0 CLK FREE FH  
 CTL8 SBUS TO P DIAG L  
 CTL8 SDIAG T0 L  
 CTL8 SDIAG T1 L  
 CTL8 SDIAG T2 L  
 CTL2 A PHS COM FREE L

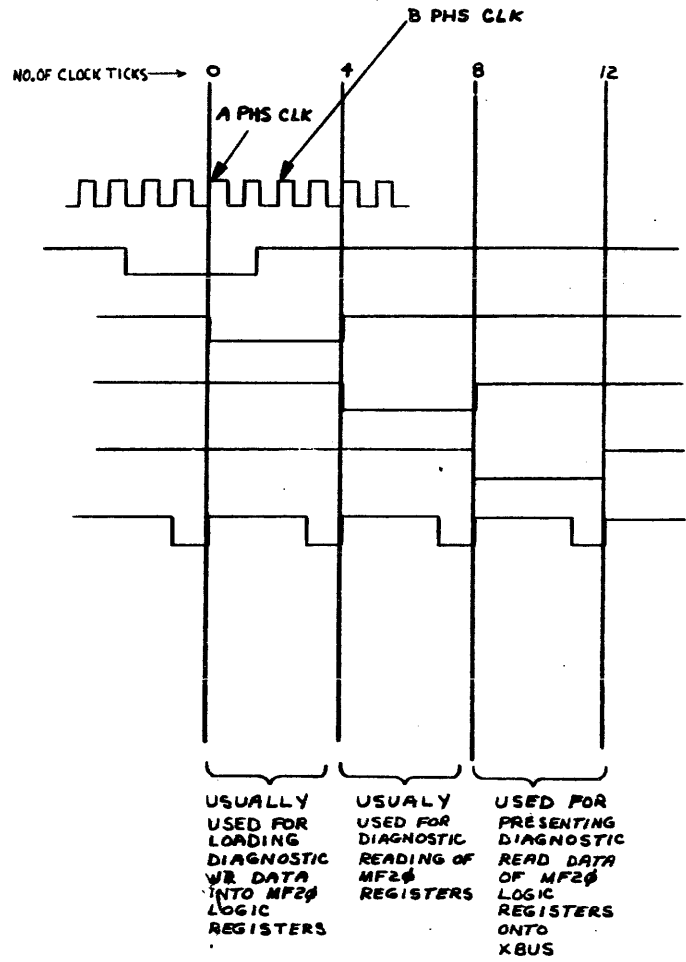

DRN. <i>E. Wilson</i>	DATE <i>11/1/78</i>	FIRST USED ON	MF20
CHKD. <i>J. Chin</i>	SCALE	TITLE	DIAGNOSTIC CYCLE TIMING DIAGRAM
ENG. <i>D. Chin</i>	<i>7-30-78</i>	PROJ. ENG. <i>J. Chin</i>	<i>530-78</i>
PROD.		NEXT HIGHER ASSY.	
B-DR-MF20-0	SIZE	CODE	NUMBER
SCALE NONE	D	TD	MF20-0-8
SHEET 1	OF 1	DIST.	

REVISIONS  
 CHANGE NO. REV.

THIS DRAWING AND SPECIFICATIONS HEREIN ARE THE PROPERTY OF DIGITAL EQUIPMENT CORPORATION AND SHALL NOT BE REPRODUCED OR COPIED IN WHOLE OR IN PART AS THE BASIS FOR THE MANUFACTURE OR SALE OF EQUIPMENT WITHOUT THE WRITTEN PERMISSION OF DIGITAL EQUIPMENT CORPORATION © 1978

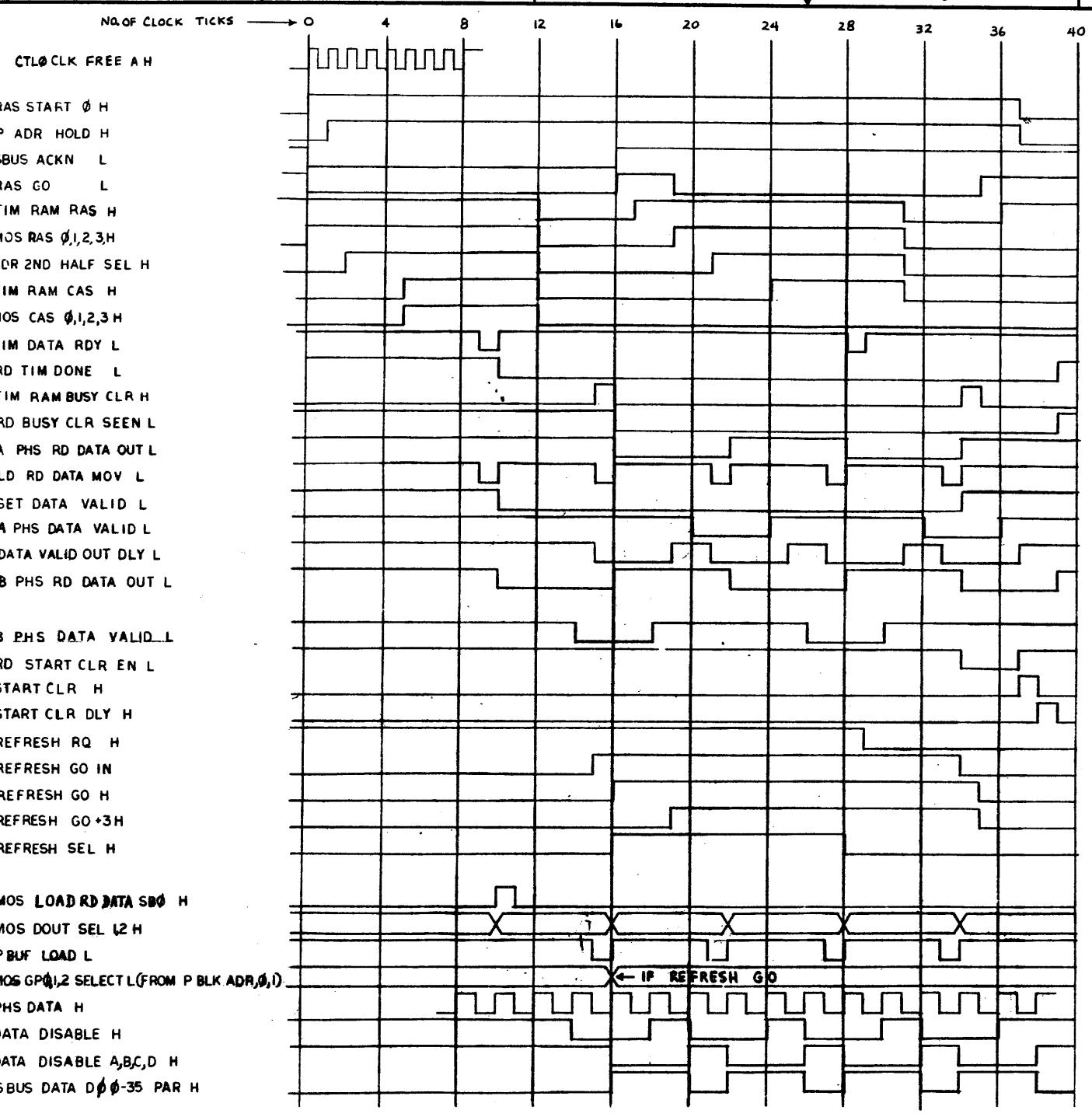

FOUR WORD TRANSFER  
RAS START 0 SHOWN BEING SET ON A PHS CLOCK. IT CAN ALSO BE SET ON B PHS CLOCK

REV.	
CHK	
CHANGE NO.	
REV.	

DRG: <i>K. C. ...</i>	FIRST USED ON: MF20
CHK: <i>J. C. ...</i>	TITLE: MF20 READ/REFRESH CYCLE TIMING DIAGRAM
ENG: <i>J. C. ...</i>	DATE: 6-2-78
PROJ. ENG: <i>J. C. ...</i>	PROJ. NO: 7-2778
PROD.	
NEXT HIGHER ASBY.	
B-D0-MF20-0	SIZE CODE: D
SCALE: NONE	NUMBER: MF20-0-9
SHEET: 1	OF: 1
DIST.	

THIS DRAWING AND SPECIFICATIONS, HEREIN ARE THE PROPERTY OF DIGITAL EQUIPMENT CORPORATION AND SHALL NOT BE REPRODUCED OR COPIED OR USED IN WHOLE OR IN PART IN THE DESIGN FOR THE MANUFACTURE OR SALE OF OTHER EQUIPMENT WITHOUT PERMISSION.  
 COPYRIGHT © 1978, DIGITAL EQUIPMENT CORPORATION

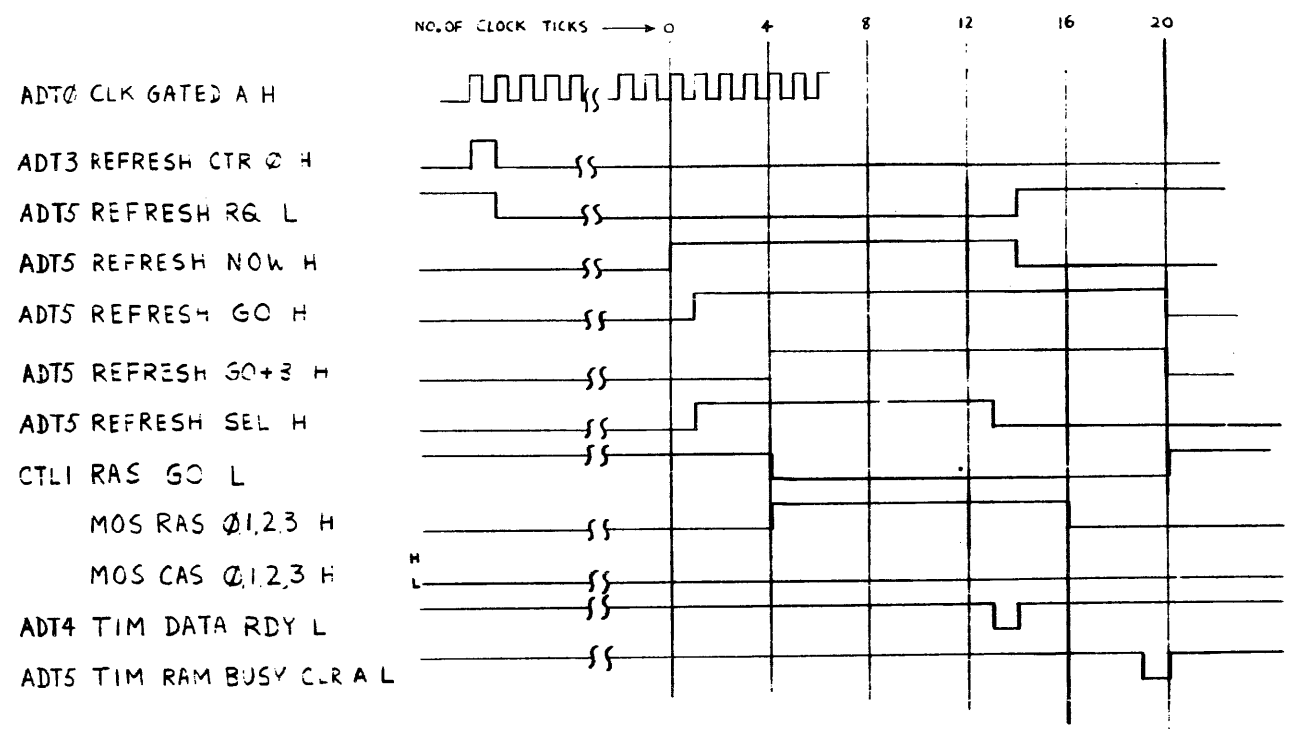

REFRESH NOW IS SET IF REFRESH INTERVAL DOWN CTR IS  $\leq 128_{10}$   
 AND REFRESH GO IS NOT YET SET

REV.	
CHK	
CHANGE NO.	

DRN. <i>E. Wilson</i>	DATE <i>19 APR 78</i>	FIRST USED ON <i>MF20</i>
CHK. <i>W. Caputo</i>	DATE <i>4-2-78</i>	TITLE <i>REFRESH CYCLE TIMING DIAGRAM</i>
ENG. <i>J. Chen</i>	DATE <i>6-1-78</i>	
PROJ. ENG. <i>J. Chen</i>	DATE <i>7-27-78</i>	
PROD.		
NEXT HIGHER ASSY.		
<i>B-DD-MF20-0</i>	SIZE CODE <i>D</i>	NUMBER <i>MF20-0-12</i>
SCALE <i>NCNE</i>	DIST.	REV.
SHEET <i>1</i>	OF <i>1</i>	

THIS DRAWING AND SPECIFICATIONS, HEREIN, ARE THE PROPERTY OF BENTON ELECTRIC CORPORATION AND SHALL NOT BE REPRODUCED OR COPIED IN WHOLE OR IN PART AS THE BASIS FOR THE MANUFACTURE OR SALE OF ANY EQUIPMENT WITHOUT THE WRITTEN PERMISSION OF BENTON ELECTRIC CORPORATION  
 COPYRIGHT © 1978, BENTON ELECTRIC CORPORATION

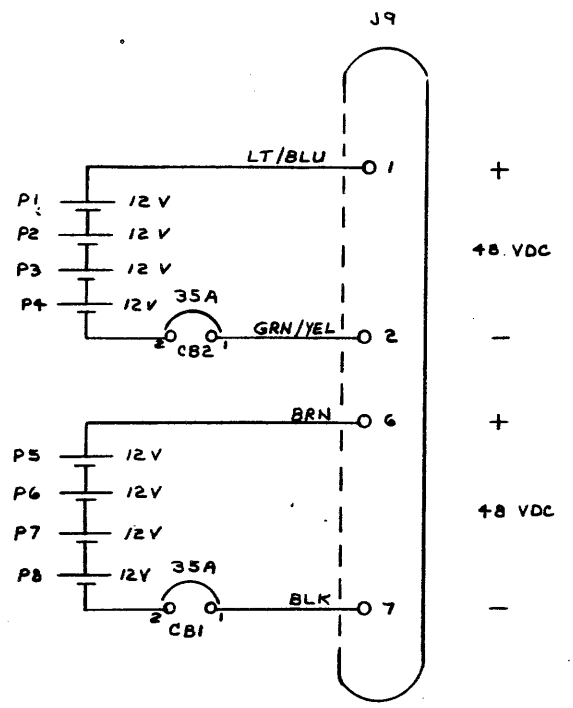

REV.	
CHK.	
CHG.	
NO.	

DRN. <i>E. Wilson</i>	12/1978	FIRST USED ON	MF20
CHK. <i>D. G. ...</i>	12/1978	TITLE	BATTERY BOX
ENG. <i>J. Chen</i>	5-30-77		BLOCK DIAGRAM
PROD. ENG. <i>J. Chen</i>	5-30-77		
PROD.			
NEXT HIGHER ASSY.			
B-DD-MF20-0		SIZE	D
SCALE	NCNE	CODE	BD
SHEET	OF	NUMBER	MF20-0-13
		REV.	

THIS DRAWING AND SPECIFICATION HEREIN ARE THE PROPERTY OF BUNTON ELECTRONIC CORPORATION AND SHALL NOT BE REPRODUCED OR COPIED IN WHOLE OR IN PART OR IN ANY MANNER WITHOUT THE WRITTEN PERMISSION OF BUNTON ELECTRONIC CORPORATION.

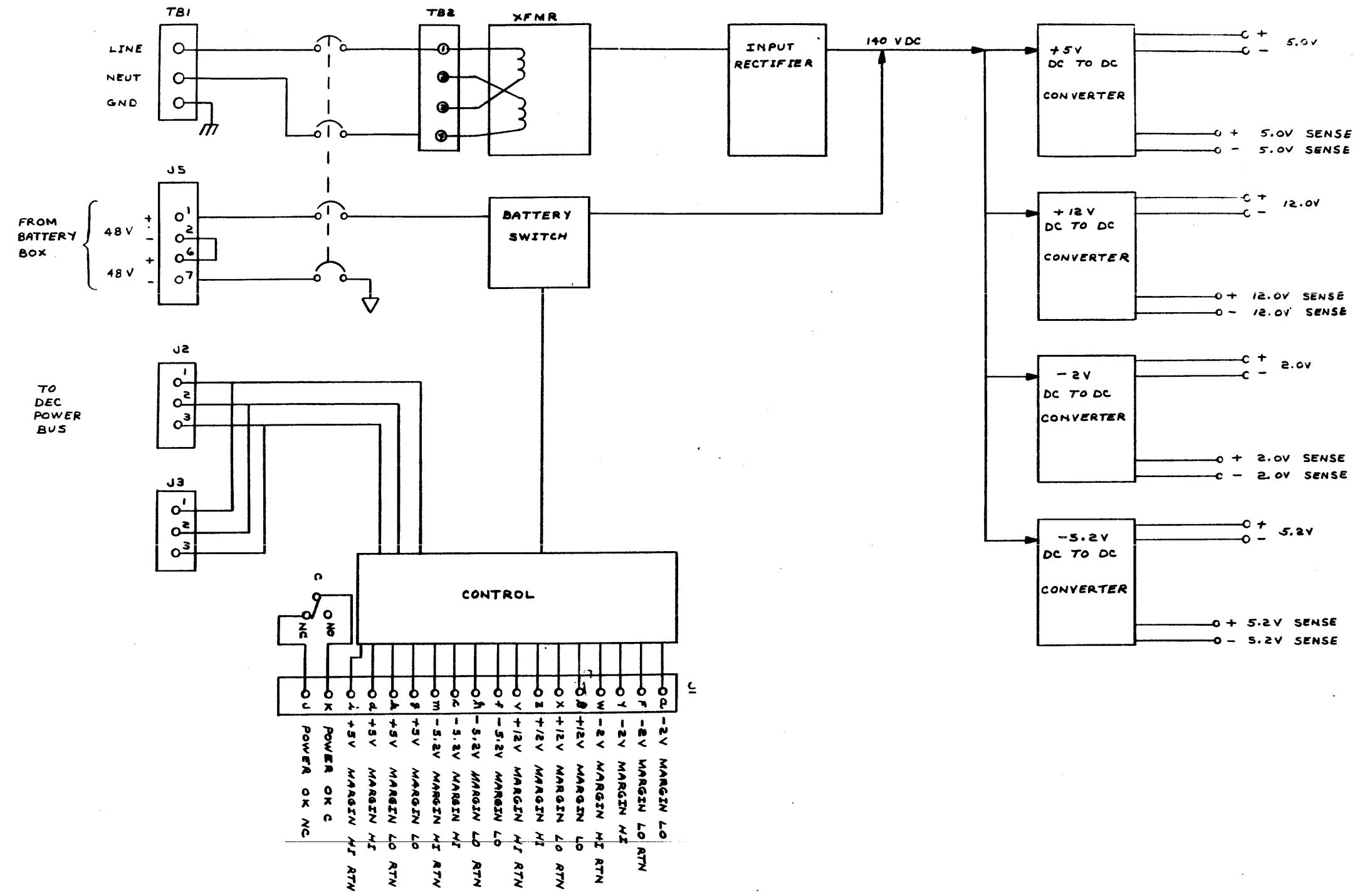

DRN: Wilson 13/01/78	FIRST USED ON: MF20
CHK: [Signature]	
ENG: [Signature]	
PROJ. ENG: [Signature]	
PROD:	
NEXT HIGHER ASSY:	
B-DD-MF20-0	SIZE CODE: D I C
SCALE: NONE	NUMBER: MF20-0-14
SHEET: 1 OF 1	DIST:

REV:	
CHG:	
NO:	

"THIS DRAWING AND SPECIFICATIONS, HEREIN, ARE THE PROPERTY OF DIGITAL EQUIPMENT CORPORATION AND SHALL NOT BE REPRODUCED OR COPIED OR USED IN WHOLE OR IN PART AS THE BASIS FOR THE MANUFACTURE OR SALE OF ITEMS WITHOUT WRITTEN PERMISSION.  
COPYRIGHT © 1978, DIGITAL EQUIPMENT CORPORATION"

NOTE:  
1. J1-J5 ARE INTERNALLY TERMINATED. WHEN J1-J5 ARE USED, CORRESPONDING JUMPERS 'N1-W5' MUST BE CUT. J6 IS NOT INTERNALLY TERMINATED.  
2. PIN 6 MUST BE ABSENT TO ACCOMMODATE POLARIZING PIN ON MATING CONNECTOR.

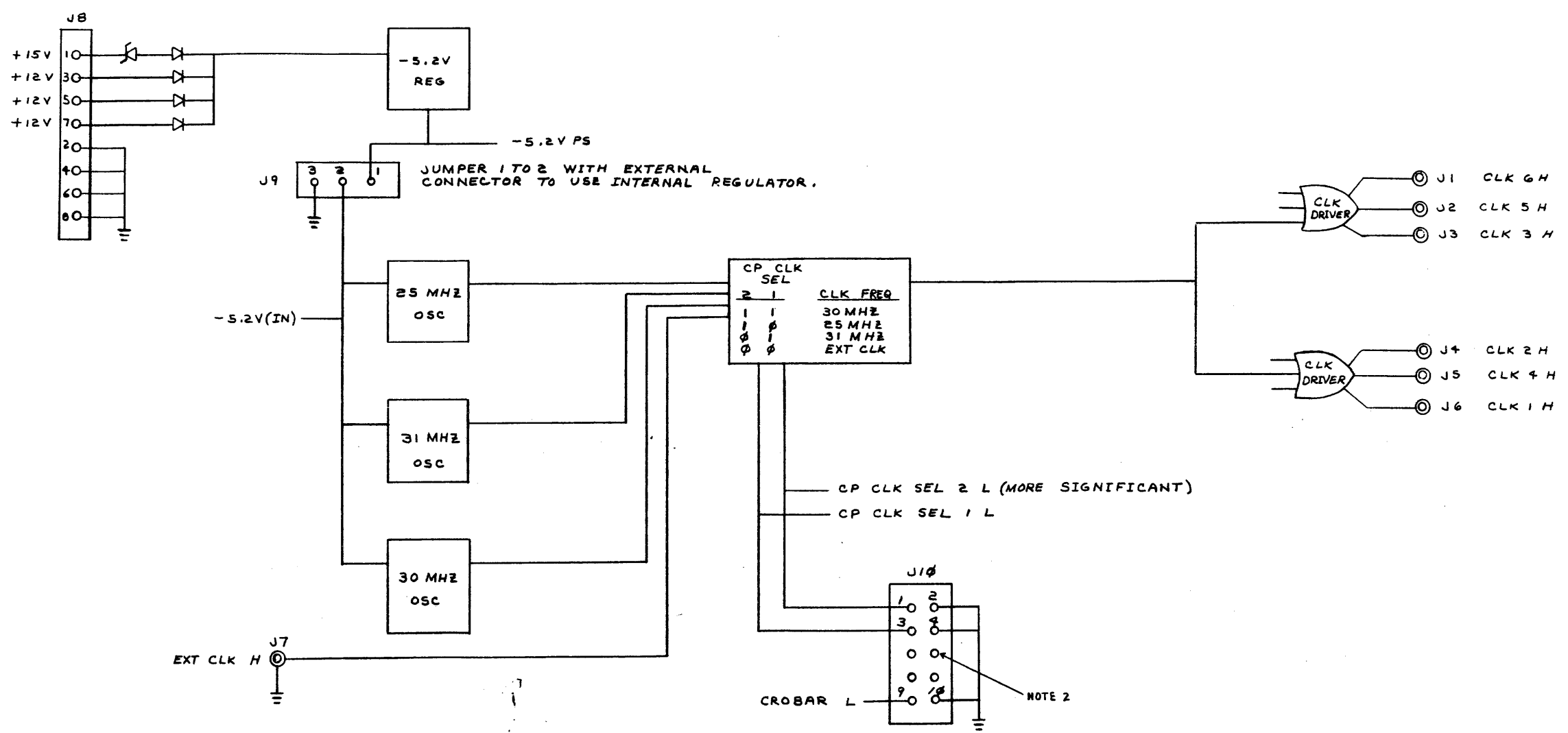

REV.	
CHK	
CHG	
NO.	

DRN. <i>William</i>	DATE <i>13 APR 78</i>	FIRST USED ON	<i>MF20</i>
CHK'D <i>W. Williams</i>	DATE <i>13 APR 78</i>	TITLE	<b>MASTER OSCILLATOR BLOCK DIAGRAM</b>
ENG. <i>J. Chen</i>	DATE <i>5-30-78</i>	SCALE	NONE
PROJ. ENG. <i>J. Chen</i>	DATE <i>5-30-78</i>	SHEET	1 OF 1
PROD.		DIST.	
NEXT HIGHER ASSY.		SIZE CODE	D
B-DD-MF20-0		NUMBER	BD MF20-0-16
SCALE	NONE	REV.	



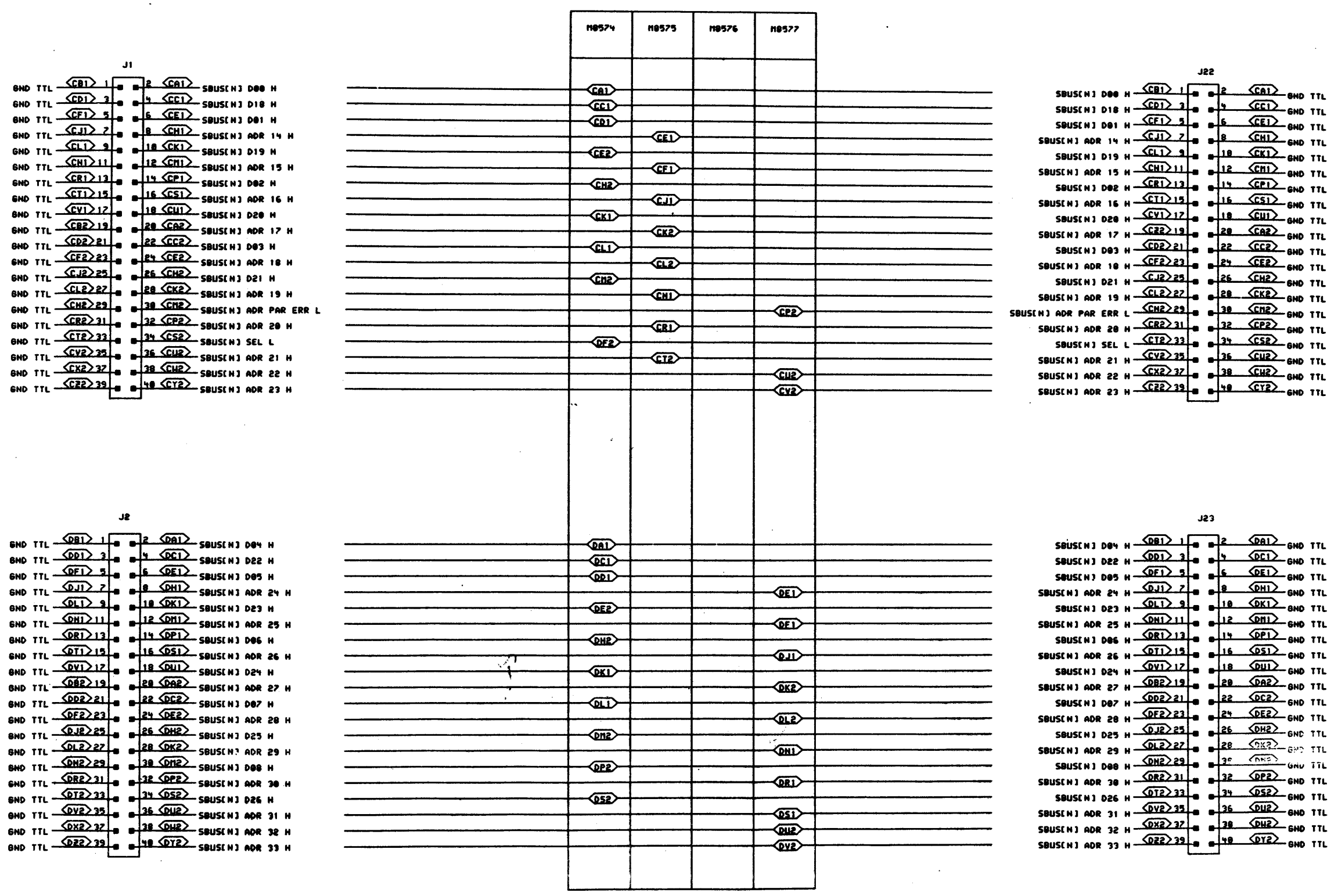

THIS DRAWING AND SPECIFICATIONS HEREIN ARE THE PROPERTY OF DIGITAL EQUIPMENT CORPORATION AND SHALL NOT BE REPRODUCED OR COPIED OR USED IN WHOLE OR IN PART AS THE BASIS FOR THE MANUFACTURE OR SALE OF ITEMS WITHOUT WRITTEN PERMISSION. COPYRIGHT © 1976. DIGITAL EQUIPMENT CORPORATION.

REVISIONS	CHK	CHANGE NO.	REV

--	--	--	--	--	--	--	--

	DRN: <i>P. L. ...</i>	DATE: 02-AUG-78	ENG: <i>J. C. ...</i>	DATE: P-3-78	TITLE: MF20 BACKPLANE XBUS CONNECTIONS
	CHK'D: <i>D. C. ...</i>	DATE: 02-AUG-78	BOARD LOCATION: 1 OF 2	SIZE: D	CODE: B5
FIRST USED ON OPTION/MODEL: MF20			NEXT HIGHER ASSEMBLY: MF20-0		NUMBER: MF20-0-19
REV.:					

REV. NUMBER  
 SIZE CODE  
 D B5  
 MF20-0-19

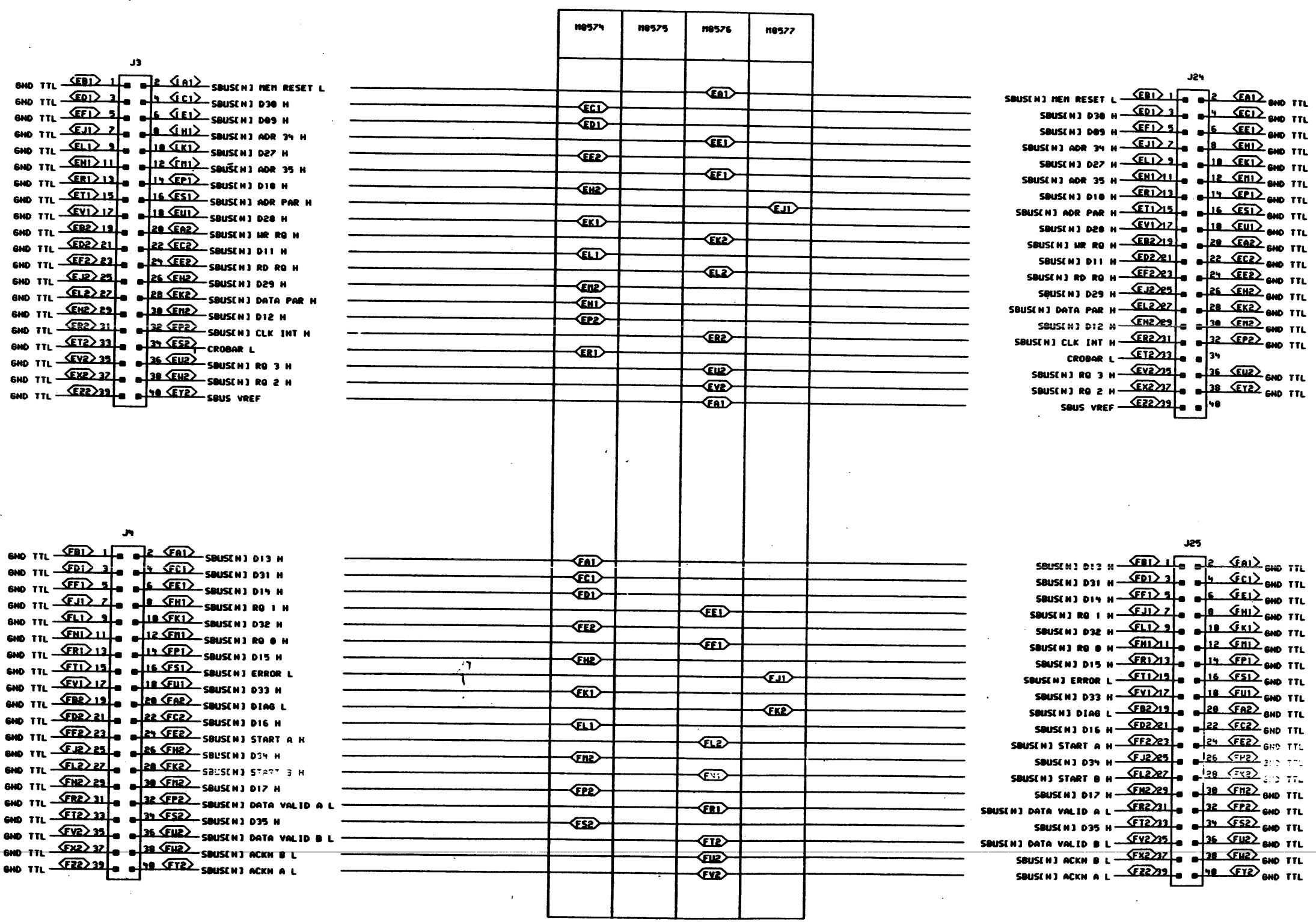

D

C

B

A

D

C

B

A

THIS DRAWING AND SPECIFICATIONS ARE THE PROPERTY OF DIGITAL EQUIPMENT CORPORATION AND SHALL NOT BE REPRODUCED OR COPIED OR USED IN WHOLE OR IN PART AS THE BASIS FOR THE MANUFACTURE OR SALE OF ITEMS WITHOUT WRITTEN PERMISSION. COPYRIGHT © 1970, DIGITAL EQUIPMENT CORPORATION.

REV.	CHG	CHANGE NO.	REV.

**digital** DRN *DeLuca* DATE ENG. *D. Chen* DATE *8-3-78* TITLE: **MF20 BACKPLANE XBUS CONNECTION**

CHK'D. *D. Chen* DATE BOARD LOCATION: SHEET 2 OF 2

PUB: (M0572-M05)BACK1.DRW 03-AUG-78 09144 NEXT HIGHER ASSEMBLY: MF20 MF20-0

FIRST USED ON OPTION/MODEL: MF20 MF20-0

SIZE CODE NUMBER REV. **D B5 MF20-0-19**

REV. NUMBER MF20-0-19

D B5 MF20-0-19

B

A

172

**DIGITAL EQUIPMENT CORPORATION**  
MAYNARD, MASSACHUSETTS

**ENGINEERING SPECIFICATION**

TITLE MF20 Sbus Clock Synchronization DATE 5/24/78

REV	DESCRIPTION	REVISIONS		
		CHG NO	DATE	APPD BY

ENG *Edward Smith* APPD *11/11/78* SIZE CODE A SP NUMBER MF20-0-SYNC REV 1 OF 6  
EN-1079A-16-R075-1021 MR

**ENGINEERING SPECIFICATION**

TITLE MF20 Sbus Clock Synchronization

- 1.0 Intention of this document
- 2.0 Test equipment required
- 3.0 Diagnostics required for testing
- 4.0 Prerequisite checks
- 5.0 Repairs necessitating readjustment
- 6.0 Adjustment procedure
- 7.0 Timing diagram
- 8.0 Verification

DEC FORM NO EN-1079A-16-R075-1021 SIZE CODE A SP NUMBER MF20-0-SYNC REV 2 OF 6  
MR

**ENGINEERING SPECIFICATION**

TITLE MF20 Sbus Clock Synchronization

- 1.0 Intention of this document  
This specification is intended to provide a method for synchronizing the bus operation of each MF20 controller with that of the KL18PV central processor. Also information is provided concerning the environment required to perform the adjustment and situations requiring the adjustment to be performed.
- 2.0 Test equipment required
  - a. DECsystem2060
  - b. Voltmeter: digital voltmeter (2 and 1/2 digits or more)
  - c. Scope: TEKTRONIX 475 or better 200MHZ BW, 1.8NS RISE TIME (2 channels and viewable external sync or 3 or more channels)
  - d. Probes: quantity three (3) probes, volts times ten (x10), of equal length for above scope.
  - e. Dip clip
  - f. Extender module: W9025, 12 inch
  - g. Screwdriver: Flat blade, 1/8 inch
- 3.0 Diagnostics required for testing
  - a. kldcp.all
  - b. ub.ram

**ENGINEERING SPECIFICATION**

TITLE MF20 Sbus Clock Synchronization

- 4.0 Voltage specifications  
Verify that the following conditions exist before proceeding to perform the adjustment.
  - a. DC voltages
    1. +12.0 volts dc +/-5%
    2. +5.0 volts dc +/-5%
    3. -2.0 volts dc +/-5%
    4. -5.2 volts dc +/-5%
  - b. SIGNAL voltages
    1. Vref 1.39 to 1.41 volts dc
      - a. Corrective measures: replace M8580 module in slot 7 of CPU.
- 5.0 Adjustments  
The following actions require the adjustment to be performed.
  - a. replacement of M8576 MOS CONTROL
  - b. replacement of M8572 XBUS CABLE  
Note: Particularly if lengths are different \*\*\*\*\*
  - c. replacement of M3526 in CPU

**ENGINEERING SPECIFICATION**

TITLE MF20 Sbus Clock Synchronization

SIZE CODE A SP NUMBER MF20-0-SYNC REV 3 OF 6

SIZE CODE A SP NUMBER MF20-0-SYNC REV 4 OF 6

# ENGINEERING SPECIFICATION

digital

CONTINUATION SHEET

TITLE MF20 Sbus Clock Synchronization

## 6.0 adjustment procedure

- a. POWER DOWN THE MF20 AND PLACE THE M8576 ON THE EXTENDER. ROTATE THE TWO SWITCHES ALL THE WAY CLOCKWISE. RESTORE POWER AND LOAD THE KL10 UCODE. MASTER RESET THE MACHINE (MR), SELECT FULL CLOCK RATE (CR0), AND SOURCE THE CLOCK FROM THE MASTER OSCILLATOR AT 30MHZ (FW72/3,CS2). NOW START THE UCODE (SM).
- b. PLACE THE PROBE FOR THE VIEWABLE EXTERNAL SYNC ON PIN E22F2 IN CPU BAY (SIGNAL "A CHANGE COMING L") AND PLACE THE GROUND CLIP ON A GND PIN.
- c. SYNC NEGATIVE EXTERNAL.
- d. PUT THE DIP CLIP ON E86 OF THE M8576 AND PLACE PROBE 2 ON E86 PIN 5 (CT A CLK DLY L). PLACE THE GROUND CLIP ON PIN 1.
- e. PLACE PROBE 1 ON E86 PIN 9 OF THE M8576 (CLK FREE) AND GND CLIP ON PIN 16.
- f. VIEW EXTERNAL SYNC AND LOCATE "A PHASE" TICK OF CLK FREE (PROBE 1). IT IS THE FIRST POSITIVE GOING PULSE AFTER THE CPU SIGNAL "A CHANGE COMING L" GOES LOW.
- g. HAVING LOCATED THE "A TICK" OF CLK FREE, WE DEFINE THE POSITIVE PULSE BEFORE "A TICK" TO BE "X TICK". WE NOW DEFINE THE POSITIVE PULSE BEFORE "X TICK" TO BE "Y TICK" (SEE 7.0 TIMING DIAGRAM ON NEXT PAGE).
- h. ROTATE THE BOTTOM SWITCH TO ALIGN THE NEGATIVE GOING EDGE OF "CT A CLK DLY L" (PROBE 2) WITH THE NEGATIVE GOING EDGE OF "Y TICK" (PROBE 1). IF THIS OPTIMAL SETTING IS NOT POSSIBLE YOU MUST ALIGN THE NEGATIVE GOING EDGE OF "CT A CLK DLY L" WITHIN THE FOLLOWING RANGE: AFTER THE POSITIVE GOING EDGE OF "Y TICK" AND BEFORE THE POSITIVE GOING EDGE OF "X TICK".
- i. MOVE PROBE 2 FROM E86 PIN 5 TO E86 PIN 6. ROTATE THE UPPER SWITCH TO ALIGN THE NEGATIVE GOING EDGE OF "CT B CLK DLY L" (PROBE 2) WITH THE NEGATIVE GOING EDGE OF "A TICK" (PROBE 1). IF THIS OPTIMAL SETTING IS NOT POSSIBLE, YOU MUST ALIGN THE NEGATIVE GOING EDGE OF "CT B CLK DLY L" WITHIN THE FOLLOWING RANGE: AFTER THE POSITIVE GOING EDGE OF "A TICK" AND BEFORE THE POSITIVE GOING EDGE OF THE PULSE FOLLOWING "A TICK".

SIZE	CODE	NUMBER	REV
A	SP	MF20-0-SYNC	

5 of 6

# ENGINEERING SPECIFICATION

digital

CONTINUATION SHEET

TITLE MF20 Sbus Clock Synchronization

## 7.0 Timing diagram

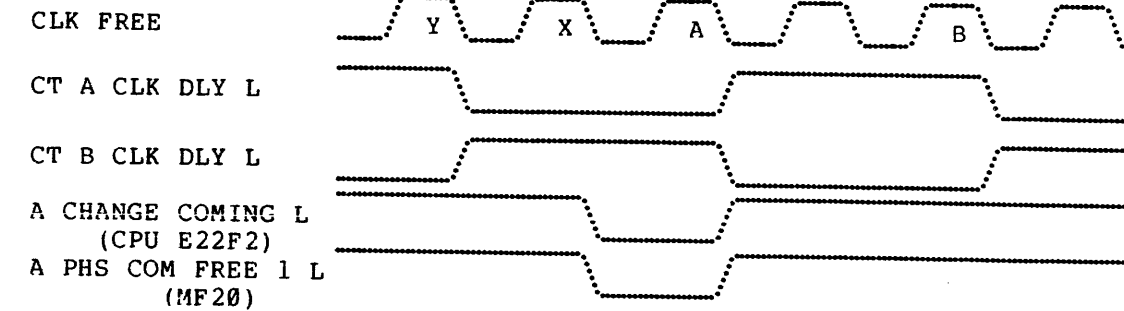

## 8.0 Verification

- a. SEMI-FINAL CHECK:  
REMOVE PROBE 1 FROM PIN 9 OF E86 AND PLACE IT ON PIN 5. THE WAVEFORMS OBSERVED ON CHAN 1 AND 2 SHOULD BE THE LOGICAL OPPOSITE OF ONE ANOTHER.
- b. FINAL CHECK:  
AT THE SCOPE, MOVE THE PROBE MONITORING "A CHANGE COMING L" FROM THE "EXT SYNC" TO "CHANNEL 1". SYNC INTERNAL ON CHAN 1. NOW REMOVE THE PROBES ATTACHED TO THE DIP CLIP AND PLACE THE DIP CLIP ON E61. PUT CHANNEL 2 PROBE ON E61 PIN 2 (SIGNAL "A PHS COM FREE 1 L" IN MF20) AND PLACE THE GROUND CLIP ON E61 PIN 16. THESE SIGNALS SHOULD BE IDENTICAL.

SIZE	CODE	NUMBER	REV
A	SP	MF20-0-SYNC	

6 of 6

**DIGITAL EQUIPMENT CORPORATION**  
MAYNARD, MASSACHUSETTS

**ENGINEERING SPECIFICATION**  
MF 20 INSTALLATION PROCEDURE

REV	DESCRIPTION	CHG NO	ORIG	DATE	APPD BY	DATE
A	REVISED	MF20-MRO06	J.M.CELRO	5 JUN 80	<i>[Signature]</i>	7/1/80
B	REVISED	MF20-MRO06	R. SCOTT	22 80	<i>[Signature]</i>	JULY 8 1980

DATE 5 March 1979

REVISIONS

**ENGINEERING SPECIFICATION**

MF20 Installation Procedure

MF20 ADD ON INSTALLATION, CHECKOUT AND ACCEPTANCE PROCEDURE

The MF20 add-on installation should be very straight-forward if you take care in following each step outlined in this procedure. However, there may be some tasks which must be completed ahead of actual MF20 installation time.

The complexity of the installation will depend on the state of the system at the customer's site. The first area of concern is the CPU cabinet rear equipment mounting door. All cabinets being built today have mounting holes and rivnuts on the CPU rear equipment mounting door to accept the MF20 power supplies (or H7429 power supplies for MA/MB20).

These holes were added to the cabinet with the introduction of the MA/MB20 add-on. However, systems built before that time do not have these holes and some of the systems built during the transition have these holes in the wrong place.

Check CPU rear door against Figure #1 to determine if these holes must be added.

Also, all cabinets being built today have mounting holes and rivnuts on the CPU cabinet rear equipment mounting door to accept the MF20 battery box. However, again all systems built before the time of this option do not have these holes. Check CPU rear door against Figure #1 to determine if these holes must be added. If holes must be added, acquire the mounting hole installation kit from your branch office (kit contains electric drill, rivnut gun, etc.) and follow the procedure at section 5.8 to drill holes before starting the MF20 installation.

Next, a pre-installation (skidded) checkout procedure is part of this document. The purpose of this skidded checkout is to determine if there is any reason why the delivered memory unit should not be mounted in the customer's system. At this point, you should be looking for "catastrophic" problems, not logic problems.

Next, in some systems the MF20 will be replacing an existing MA or MB20. If this is the case, follow the removal procedure starting with section 7.0 before starting MF20 installation. NOTE: however, that skidded checkout of MF20 should be completed before removal of MA/MB20 is started.

DEC FORM NO EN-01022-16-N370-13A11  
DRA 108

DEC FORM NO EN-01022-16-N370-13A11  
DRA 108

**ENGINEERING SPECIFICATION**

MF20 Installation Procedure

Finally, before beginning the installation, read through the entire procedure and familiarize yourself with all diagrams and required parts. Make certain you have all the required parts.

**ENGINEERING SPECIFICATION**

MF20 Installation Procedure

TABLE OF CONTENTS

- 1.0 Installation Overview
- 2.0 MF20 Add-On Parts List
- 3.0 Applicable Documents and Diagnostics
- 4.0 Required Tools and Test Equipment
- 5.0 Mounting Hole Check and Installation
- 6.0 MF20 Pre-Installation (Skidded) Checkout
- 7.0 MA/MB20 Removal
- 8.0 MF20 #1 Mounting Procedure
- 9.0 MF20 #2 Mounting Procedure
- 10.0 Cabling and Wiring Procedure
- 11.0 External Memory Cabinet Add-On
- 12.0 Preliminary Electrical Checkout
- 13.0 Checkout and Acceptance Procedure
- 14.0 External memory add-on (MF20-LP/LR,LS/LT only)
- 15.0 Internal memory (MF20-LU/LV only)

SIZE CODE SP A

NUMBER MF20-0-2

REV B

SHEET 3 OF 62 MR

SIZE CODE SP A

NUMBER MF20-0-2

REV B

SHEET 4 OF 62

ENGINEERING SPECIFICATION	CONTINUATION SHEET
MP20 Installation Procedure	
TITLE	
1.0 INSTALLATION OVERVIEW	
To help eliminate possible confusion in the installation, this overview is provided to give you a brief outline of all steps necessary to successfully install this option. These steps are listed in the order in which they must be performed. Any attempt to alter this sequence of events will create problems at your customer site. You should also be warned that this outline is just a brief description of the steps to help firm up the order and scope of the installation in your mind. The in-depth description of the procedure in Sections 3.0 - 13.0 must be followed when the installation is in process.	
The installation should follow these steps:	
1.1	Determine if mounting holes must be added to CPU cabinet rear equipment mounting door. Add if necessary.
1.2	Determine if the processor is a KL10-E complete to Rev 4 with the appropriate diagnostic software if not, obtain the ECO and install it.
1.3	If and only if the installation is an external cabinet, then the rear card cage door Assy (D-AD-7016755-g-g), the hanger bracket (D-NO-7420000-g-g) must be installed prior to installation. If the MF20 is an internal box then this is not necessary.
1.4	System operation must be verified if wire adds are installed.

DEC FORM NO EN-0102-14-N370-1381  
 DRA 108

SIZE CODE A SP  
 NUMBER MF20-0-2  
 REV B  
 SHEET 5 OF 62 MR

ENGINEERING SPECIFICATION	CONTINUATION SHEET
MP20 Installation Procedure	
TITLE	
NOTE: Steps 1.1 - 1.4 should be done prior to the scheduled installation date.	
1.5	Appropriate CPU modules must be swapped.
1.6	Connections must be made between skidded equipment and the CPU.
1.7	Pre-installation (skidded) checkout must be performed.
1.8	Connections between the skidded equipment and the CPU must be removed.
1.9	If MA or MB20 is present on rear equipment mounting door it must be removed.
1.10	Master Oscillator (if necessary), MF20, power supply and battery box must be mounted.
1.11	All necessary cables must be installed and connections made.

DEC FORM NO EN-0102-14-N370-1381  
 DRA 108

SIZE CODE A SP  
 NUMBER MF20-0-2  
 REV B  
 SHEET 6 OF 62

ENGINEERING SPECIFICATION	CONTINUATION SHEET		
MP20 Installation Procedure			
TITLE			
1.12			
Final checkout and field acceptance must be run.			
At this point, the installation is complete and another satisfied customer has use of a properly installed and functioning MF20.			
2.0 MF20 ADD-ON PARTS LIST			
Item	Part Number	Description	Qty
1	MF20	Memory Complete	1
2	9007786	Tinnerman Nuts 10-32	16
3	9007892	Riv Nuts 10-32	22
4	9006074-03	Screws 10-32 X .62	43
5	9006635	Lock Washer #10	39
6	9007651	Lock Washer #18	11
7	9006565	Key Nut 10-32	12
8	9007880	Tie Wraps	48
9	9008264	Stick Mounts	25
10	9007032	Tie Wraps	48
11	9006071-03	Screw 10-32 X .38	6
12	9008203	Key Nut 1/4-20	1
13	9006724	Lock Washer 1/4 in	1
(Items 11, 12, 13 are used only on ext MF20 cab.)			
3.0 APPLICABLE DOCUMENTS AND DIAGNOSTICS			
3.1		Documentation:	
1.	MF20 Maintenance Print Set	Technical	Manual
2.	MOS Memory (EK-0MF20-TM-0)	Subsystem	Manual
3.	MF20 SBUS Clock Sync (A-SP-0MF20-SYNC)		

DEC FORM NO EN-0102-14-N370-1381  
 DRA 108

SIZE CODE A SP  
 NUMBER MF20-0-2  
 REV B  
 SHEET 7 OF 62 MR

ENGINEERING SPECIFICATION	CONTINUATION SHEET
MP20 Installation Procedure	
TITLE	
3.2	
Diagnostics:	
1.	KLDCP.BIN
2.	DIAGS.RAM
3.	DHRBA.ALL
4.	DHRBF.ALL
5.	DHRBG.ALL
6.	UB.RAM
7.	MEMCON.ALL
8.	DFMMH.A10
9.	SUBKL.A10
4.0 REQUIRED TOOLS	
4.1	
Standard Tools and Test Equipment	
1.	Scope: Tektronix 475 or equiv.
2.	Digital Volt Meter
3.	DIP clip
4.	Phillips screwdrivers (#2 and #3)
5.	Dykes
6.	Blade screwdriver
7.	Adjustable wrench

DEC FORM NO EN-0102-14-N370-1381  
 DRA 108

SIZE CODE A SP  
 NUMBER MF20-0-2  
 REV B  
 SHEET 8 OF 62

ENGINEERING SPECIFICATION		CONTINUATION SHEET
MF20 Installation Procedure		
TITLE		
<p>8. Trim pot "tweezer"</p> <p>9. 3/8 inch electric drill</p> <p>10. Drill Bits (5/32 and 1/4 inch)</p> <p>11. Center punch</p> <p>12. W9025 extender module</p> <p>13. Torque wrench (not necessary for normal installation, just for replacing bad power supplies).</p>	<p>Special Tools Included in MF20 Controlled Distribution "kit".</p> <p>1. M8572-YA (with 13 ft. xbus cable)</p> <p>2. Riv-nut tool</p> <p>3. 3/4" box wrench</p>	<p style="text-align: center;">SIZE CODE <b>A</b></p> <p style="text-align: center;">NUMBER <b>2</b></p> <p style="text-align: center;">REV <b>B</b></p>
<p>4.2</p> <p>Special Tools Shipped with MF20</p> <p>1. Battery box mounting template.</p>		

DEC FORM NO. EN-01022-16-N370-(381)  
DRA 108

SHEET 9 OF 52 MR

ENGINEERING SPECIFICATION		CONTINUATION SHEET
MF20 Installation Procedure		
TITLE		
<p>5.0 MOUNTING HOLE CHECK AND INSTALLATION</p> <p>5.1</p> <p>Check CPU cabinet rear equipment mounting door for holes and rivnuts in the short member of the door frame as seen in Figure #1. These are the ten (10) mounting holes (2 sets of 5 holes each) on the inside of the door member.</p> <p>Hint: If the system presently has #7420 power supplies mounted in this position for an MA/MB20 add-on, these holes are already present.</p> <p>5.2</p> <p>Check CPU cabinet rear equipment mounting door for holes and rivnuts in the members to accept the battery box as seen in Figure #1. These are the holes to be installed by the template shown in Figure #2.</p> <p>5.3</p> <p>If any holes must be added, contact the office and acquire the mounting hole installation kit.</p> <p>5.4</p> <p>If holes for mounting the power supplies must be added, contact Product Support in Marlboro, phone number (617) 481-9511, extension 6903.</p> <p>A template can be provided to help locate these holes also. This template will not be provided with each kit due to the extremely limited number of machines produced without these holes.</p> <p>5.5</p> <p>A significant number of systems were built without the battery box mounting holes. Therefore, a template to locate these holes will be supplied with every MF20 - LA/LB shipped to the field.</p>	<p style="text-align: center;">SIZE CODE <b>A</b></p> <p style="text-align: center;">NUMBER <b>2</b></p> <p style="text-align: center;">REV <b>B</b></p>	

DEC FORM NO. EN-01022-16-N370-(381)  
DRA 108

SHEET 10 OF 52

ENGINEERING SPECIFICATION		CONTINUATION SHEET
MF20 Installation Procedure		
TITLE		
<p>5.6</p> <p>Using Figure #1 as a reference, place the template in place with the template bottom flange on top of door bottom member and the side flanges outside the two vertical members.</p> <p>5.7</p> <p>Using a 5/32 inch drill, drill out all necessary pilot holes.</p> <p>5.8</p> <p>Remove the template.</p> <p>5.9</p> <p>Using a 1/4 inch drill, enlarge all necessary holes.</p> <p>5.10</p> <p>Using a rivnut tool install rivnuts (item #3) in all necessary holes.</p> <p>5.10.1</p> <p>To use the rivnut tool (figure #2A). Place rivnut (item #3) on pull up stud until the first thread becomes exposed at the end of the rivnut as seen in figure #2B.</p> <p>5.10.2</p> <p>Rotate the hex nut (body) counter clockwise until the anvil makes contact with the shoulder of the rivnut as seen in figure #2C.</p>	<p style="text-align: center;">SIZE CODE <b>A</b></p> <p style="text-align: center;">NUMBER <b>2</b></p> <p style="text-align: center;">REV <b>B</b></p>	

DEC FORM NO. EN-01022-16-N370-(381)  
DRA 108

SHEET 11 OF 52 MR

ENGINEERING SPECIFICATION		CONTINUATION SHEET
MF20 Installation Procedure		
TITLE		
<p>5.10.3</p> <p>Insert rivnut in hole (with rivnut tool attached). Place 3/4 inch wrench over body hex nut (box end of wrench is preferred) and place the hex wrench in the hex wrench socket.</p> <p>5.10.4</p> <p>Holding tool stationary by the hex wrench, turn the body hex nut counter clockwise one to one and one half (1-1 1/2) turns with the 3/4 inch wrench. Resistance to turning after about one full run will indicate that compression is complete.</p> <p>5.10.5</p> <p>Turn body hex nut 1/2 turn in the clockwise direction to loosen the tool. Remove the wrenches and remove the rivnut tool by turning the hex wrench socket counter clockwise.</p> <p>5.11</p> <p>Repack mounting hole installation kit and return to the branch office so that others may be able to use it.</p> <p>6.0 MF20 PREINSTALLATION (SKIIPPED) CHECKOUT</p> <p>6.1</p> <p>Run BB.CMD to verify that the system is operational.</p> <p>6.2</p> <p>Power down the system.</p>	<p style="text-align: center;">SIZE CODE <b>A</b></p> <p style="text-align: center;">NUMBER <b>2</b></p> <p style="text-align: center;">REV <b>B</b></p>	

DEC FORM NO. EN-01022-16-N370-(381)  
DRA 108

SHEET 12 OF 62

## ENGINEERING SPECIFICATION

TITLE MF20 Installation Procedure

## ENGINEERING SPECIFICATION

TITLE MF20 Installation Procedure

- 6.3 Check to see that the backplane is a KL10PV model B backplane. A quick check is to look at the connector for the external clock input below slot 9. It must be the threaded type.
- 6.4 Make sure the processor is a KL10-E at Rev 4 with appropriate software if not, it must be updated first.
- 6.5 Power the system back up and run BB.COMD again to verify that system runs with the update added.  
NOTE: Steps 1 thru 5 should be done prior to scheduled installation date.
- 6.6 Power down the system.
- 6.7 Remove the outer cabinet doors from the front left I/O bay and from the rear of both the I/O bay and CPU bay.
- 6.8 Remove the orange front top panel (grill) from the I/O bay. (Also: Remove the UL screen if present.)

DEC FORM NO EN-01022-16-MF20-1381  
DRA 108

SIZE CODE A SP  
NUMBER MF20-0-2  
REV B

SHEET 13 OF 62 MA

- 6.9 Place the shipping skid with MF20, power supply, battery box, etc. still mounted (cardboard box and plastic bag removed) as close to the rear of the I/O cabinet as possible (with I/O cabinet rear doors open and the power supply end towards the I/O bay). If access to the rear of the cabinet is limited place the skidded memory in front of the cabinet as close as possible with the power supply towards the I/O bay.

- 6.10 Replace M8519 modules in CPU slots 7 & 8 with M8580 modules.
- 6.11 Remove any SBUS cables from slots 2 & 3 in CPU.
- 6.12 Install clock select harness in M8572-YA by plugging either end into J5 on M8572-YA.
- 6.13 Install M8572-YA in slot 2 of CPU. (It is sometimes helpful to use a sheet of plastic from a listing cover to put between the M8572-YA and the E-BUS and C-BUS cables to prevent snagging).
- 6.14 Replace SBUS cables from MA/MB 20 below CPU in slot 3.

DEC FORM NO EN-01022-16-MF20-1381  
DRA 108

SIZE CODE A SP  
NUMBER MF20-0-2  
REV B

SHEET 14 OF 62

## ENGINEERING SPECIFICATION

TITLE MF20 Installation Procedure

## ENGINEERING SPECIFICATION

TITLE MF20 Installation Procedure

- 6.15 Plug XBUS into MF20 backplane. Top cable on M8572-YA board goes to the jack below the led on the MF20 (bottom to bottom, etc.). Make sure the cables are installed in the left side of the MF20, looking from the front (pin side).
- 6.16 Place strain relief over cables on side of MF20 card cage.
- 6.17 To facilitate the skidded checkout the master oscillator must be installed in the system. This unit in no way interferes with the existing system and may be left installed (but unplugged) if for some reason the system is to be operated between the skidded checkout phase and the final installation. This would eliminate unnecessary dismounting and remounting the same equipment.
- 6.18 Disconnect all cables connected to the master oscillator.
- 6.19 Add Tinnerman Nuts (item 2) to rails in I/O cabinet as seen in drawing E-UA-MF20-0-0 sheet #3 in holes #12 and 17 in the left hand rail (as seen from front) and holes #12 and 17 in the right hand rail, counting from the top down.
- 6.20 Remove mounting screws securing the master oscillator to the shipping skid.

DEC FORM NO EN-01022-16-MF20-1381  
DRA 108

SIZE CODE A SP  
NUMBER MF20-0-2  
REV B

SHEET 15 OF 62 MA

- 6.21 Install the master oscillator in the I/O cabinet from the front as seen in drawing E-UA-MF20-0-0 sheet #3 using screws (item 4) and lock washers (item 5). ALSO: Add option jumper for Master Oscillator to CPU backplane from pin 4D43B1 to 4D44B1. (APR ID JUMPER) Also add option jumpers to MF20 backplanes per chart on sheet 9 of drawing E-UA-MF20-0-0 so that each controller will have a unique number. Install "DESEL CYC DISABLE" jumper per same drawing.

- 6.22 See D-IC-MF20-0-3, MF20 cable diagram.  
Connect black coax cables as shown  
Connect Master Oscillator DC power harness as shown  
Connect Master Oscillator AC fan harness as shown  
Connect clock select cable to the Master Oscillator

NOTE: Make sure the jumper is cut in the Master Oscillator for each coax connector occupied. If not, do so. (J1 cut W1, J2 cut W2, etc.)

- 6.23 Open the MF20 logic door and unplug all the modules moving them back about one inch so that no electrical connection is made to backplane.
- 6.24 Plug the MF20 power supply AC power cord into the 863 socket J24, by means of disconnecting H7420 power cord and replacing it with MF20 power supply cord.  
Both H7420's should be unplugged and replaced with MF20 power supply. The SBUS cables should be unplugged and "bagged", and J5 should be unplugged from vane switch below MA/MB. This will allow the memory to just hang on the door, dead to the world.

DEC FORM NO EN-01022-16-MF20-1381  
DRA 108

SIZE CODE A SP  
NUMBER MF20-0-2  
REV B

SHEET 16 OF 62

ENGINEERING SPECIFICATION		CONTINUATION SHEET	
TITLE MF20 Installation Procedure		NUMBER MF20-0-2	
<p>(NOTE: These H7420's are located on the CPU rear equipment mounting door).</p>			
6.25	Connect cable 700288-15 from J2 on one power supply to J4 of the rear of the switch panel that houses the on/off switch for the system.		
6.26	Power up the system and power up the MF20 power supply.		
6.27	Check the power supply voltages at the MF20 backplane terminal block (from left to right) -2V, gnd, -5.2V, gnd, -5.2V, gnd, +5V, gnd, +12V, gnd, +12V and gnd. Voltages should be + or - 10% at this point.		
6.28	Power down the MF20 and plug all of the modules back in and power it up back up.		
6.29	Check the voltages at the MF20 backplane again as above only this time the voltages should be + or - 2%.		
6.30	Check S-BUS "VREP" by placing D.V.M. on pin F5A1 on MF20 it should read +1.46 +/- .02 volts. If "VREP" is not within specifications, replace the M8580 or M8581 in slot 7 of the CPU backplane. HWT: If a new board is not available, switch the boards in slot 7 & 8 to obtain the same results. Also check "VREP" on MF20 pin F5D1. If this is bad, replace the M8576.		

DEC FORM NO EN-01022-16-N370-1081  
DRA 108

SHEET 17 OF 62 MR

ENGINEERING SPECIFICATION		CONTINUATION SHEET	
TITLE MF20 Installation Procedure		NUMBER MF20-0-2	
6.31	Check the X-BUS clock sync with a scope using the following quick check. Boot strap load KLDCP. Set X-BUS sync as follows: NOTE: The nominal setting of the 2 switches on the M8576 for XBUS deskew ADJ. is as follows: 13 ft. XBUS cable; turn each switch all the way clockwise and back off 1 click. 3 ft. 8 in. XBUS cable; turn each switch all the way clockwise and back off 2 clicks.		
6.32	Set scope to 1V/DIV for both chan 1 and chan 2. Set sweep rate to 20NSEC/DIV. Load the KL18 microcode. Select full clock rate and source the clock from the master oscillator at 30MHz. Start the microcode. (CR0, FW72/3, CS2, SM).		
6.33	Place probe 1 on pin E22F2 in the CPU bay (signal "A change coming L") and place the clip on a ground pin. Place probe 2 on pin D5D1 in MF20 (signal "CTL2 a PHS COM FREE L") and place the clip on a ground pin. Synchronize internal on chan 1. These signals must be identical.		
6.34	Move probe 1 from CPU bay to MF20 at pin C5M2 (signal "CTL2 B PHS COM FREE L") and place the clip on a ground pin. Set the scope to add channel 1 with channel 2. The waveform observed must be perfectly symmetrical with respect to on/off time.		

DEC FORM NO EN-01022-16-N370-1081  
DRA 108

SHEET 18 OF 62

ENGINEERING SPECIFICATION		CONTINUATION SHEET	
TITLE MF20 Installation Procedure		NUMBER MF20-0-2	
6.35	If the sync does not check the X-bus must be synchronized by following drawing A-SP-MF20-SYNC. If the sync does check then proceed.		
6.36	Run diagnostics DKBA.All & DHKBF.All		
6.37	Power system down. At this point the skidded checkout is complete and it should be determined which of three possible steps is to come next. 6.37.1 If you are going to proceed with the installation and a rear door mounted MA/MB20 is to be removed, skip the remainder of this section and go to section 7.8 and continue. 6.37.2 If you are going to proceed with the installation and there is no memory to be removed, skip the remainder of this section and go to section 8.0 and continue. 6.37.3 If you are going to abort the installation and the system is to be made operational at this point, complete this section. (6.8)		
6.38	Unplug the MF20 X-bus cable (m8572) from the CPU.		

DEC FORM NO EN-01022-16-N370-1081

SHEET 19 OF 62 MR

ENGINEERING SPECIFICATION		CONTINUATION SHEET	
TITLE MF20 Installation Procedure		NUMBER MF20-0-2	
6.39	Disconnect the clock select harness from the M8572 module.		
6.40	Disconnect the master oscillator external clock cable from the external clock fixture below slot 9 of the CPU.		
6.41	Disconnect all cables from the master oscillator. Remove Master Oscillator option bit APR ID (Pin 4D43A1 to 4D48B1).		
6.42	Reconnect the internal memory power supplies and S-BUS (if present).		
6.43	Reconnect the MA/MB20 vain switches. (J5)		
6.44	Remove the M8580 modules from the CPU slots 7 & 8 and replace the M8519.		
6.45	Replace the external cabinet doors and front grill removed in steps 7 and 8 of this section.		

DEC FORM NO EN-01022-16-N370-1081  
DRA 108

SHEET 20 OF 62

ENGINEERING SPECIFICATION		CONTINUATION SHEET	
TITLE MP28 Installation Procedure		SIZE CODE A SP	NUMBER MP28-0-2 REV B
6.46	Move skidded memory away from system.		
6.47	Power up system and run BB.COMD again to verify system operation.		
7.0	MA/MB28 REMOVAL		
7.1	If the system has an MA28 or an MB28 installed on the I/O cabinet rear equipment mounting door, it must be removed before installation of the MP28 can begin. (To avoid embarrassment make certain MP28 has passed skidded checkout before removing MA/MB28.)		
7.2	Power system down.		
7.3	Remove the logic doors from the CPU logic housing and MA/MB28 logic housing and disconnect and remove the S-bus cable, then replace the logic doors on the memory. The CPU logic doors may be left off until the MP28 is installed and cabled.		
7.4	Unplug the two (2) H7428 power supplies from the extension cords that plug into the 863 power controller at J24 and J26. These cords may be used for the MP28 later.		

DEC FORM NO EN-01022-16-N370-(381)  
DRA 108

SHEET 21 OF 62 MR

ENGINEERING SPECIFICATION		CONTINUATION SHEET	
TITLE MP28 Installation Procedure		SIZE CODE A SP	NUMBER MP28-0-2 REV B
7.5	Disconnect any ground straps from the H7428 power supplies.		
7.6	Disconnect the Mate-N-Lock at the memory door switch and cut tie wraps to free up door switch wire.		
7.7	Disconnect the Mate-N-Lock at the memory vane switch assembly and cut tie wraps necessary to free up this section of fault harness.		
7.8	Disconnect the red and white twisted pair from the memory blower and cut tie wraps necessary to free wire back to the H7428. Disconnect AC to the fans of the L7428.		
7.9	Disconnect the Mate-N-Lock connectors at the H7428 power supplies and cut necessary tie wraps to free up D.C. harness to allow it to hang free at the memory.		
7.10	Remove H744 and H754 regulators from the H7428 power supplies and set them aside.		
7.11	Remove mounting screws and dismount the H7428 power supplies and set them aside. Save removed hardware for later use.		

DEC FORM NO EN-01022-16-N370-(381)  
DRA 108

SHEET 22 OF 62

ENGINEERING SPECIFICATION		CONTINUATION SHEET	
TITLE MP28 Installation Procedure		SIZE CODE A SP	NUMBER MP28-0-2 REV B
7.12	Remove the air duct assembly from the memory and set it aside. Save removed hardware for later use.  DO NOT ATTEMPT THE NEXT STEP WITH LESS THAN TWO PEOPLE		
7.13	Remove mounting screws and carefully lift out the MA/MB28 memory and set it aside. Save removed hardware for later use.		
7.14	At this time proceed with the MP28 installation in Section 8.8. After installation is complete, mount the MA/MB28 memory on the empty MP28 shipping skid using saved hardware.		
7.15	Mount the H7428 power supplies on the skid using saved hardware.		
7.16	Replace the H744 and H754 regulators in the H7428 power supplies.		
7.17	Replace the air duct on the memory logic assembly.		
7.18	Package all remaining MA/MB28 parts and equipment for shipment back to Marlboro.		

DEC FORM NO EN-01022-16-N370-(381)  
DRA 108

SHEET 23 OF 62 MR

ENGINEERING SPECIFICATION		CONTINUATION SHEET	
TITLE MP28 Installation Procedure		SIZE CODE A SP	NUMBER MP28-0-2 REV B
8.0	MP28 81 MOUNTING PROCEDURES		
8.1	Power system down.		
8.2	Remove the outer cabinet doors from the front left I/O bay and from the rear of both I/O bay and CPU bay.		
8.3	Remove the orange front top panel (grill) from the I/O bay. (If not done previously).		
8.4	Remove the MB519 modules from slots 7 & 8 and replace them with MB588.		
8.5	Disconnect the DC and sense harnesses from the MP28 back plane.		
8.6	Check to see that the CPU cabinet rear equipment mounting door has tinnerman nuts (item 2) in holes #2,4,11, and 13 as seen in drawing E-UA-MP28-8-8 sheet #2. If not, add them.  ** NOTE: If system has cabinet locking feature added, the door locking bracket on the I/O cabinet rear equipment mounting door should be removed and all hardware saved for re-installation after the MP28 installation is complete.		

DEC FORM NO EN-01022-16-N370-(381)  
DRA 108

SHEET 24 OF 62

**ENGINEERING SPECIFICATION** **MF20** Installation Procedure CONTINUATION SHEET

TITLE	MF20 Installation Procedure
8.7	Remove the mounting screws securing the MF20 power supply to the shipping skid and remove the power supply and set it aside.
8.8	Remove the power supply mounting bracket from the shipping skid.
8.9	Install the power supply mounting bracket on the CPU cabinet rear equipment mounting door using screws (item #4) and lock washers (item #5) as seen in print E-UA-MF20-8-8 sheet #3 (view section A-A).
8.10	Install the power supply in the bottom position of the CPU cabinet rear equipment mounting door as seen in drawing E-UA-MF20-8-8 sheet #2. (You may need 2 people for this step).
8.11	Remove the mounting screws securing the MF20 battery box to the shipping skid.
8.12	Install the battery box in the CPU cabinet rear equipment mounting door as seen in drawing E-UA-MF20-8-8 sheet #2 using screws (item 4) and lock washers (item 5).

DEC FORM NO. EN-31022-16-M370-1(81)  
DRA 108  
SIZE CODE **A** NUMBER **MF20-8-8** REV **B**  
SHEET **25** OF **62** MK

**ENGINEERING SPECIFICATION** **MF20** Installation Procedure CONTINUATION SHEET

TITLE	MF20 Installation Procedure
8.13	Move cables out of the way to avoid damage and close the CPU cabinet rear doors and open the I/O cabinet rear doors and equipment mounting door.
8.14	Add tinnerman nuts (item 2) to holes #5, 6, 36, and 37 in both the left and right hand top equipment mounting rails of the I/O cabinet rear equipment mounting door as seen in drawing E-UA-MF20-8-8 sheet #2.
8.15	Remove the mounting screws securing the MF20 logic to the horizontal mounting bars, and remove the MF20 logic from the shipping skid. Set this logic aside for the moment making certain that the logic is set on the floor on its back side (rear logic door down, back plane and logic pins up).
8.16	Remove the mounting screws securing the horizontal mounting bars to the shipping skid.
8.17	Install the horizontal mounting bars in the I/O cabinet rear equipment mounting door as seen in drawing E-UA-MF20-8-8 sheet #2 using screws (item 4) and lock washers (item 5).
8.18	Remove the intake bezel from the MF20 housing.

DEC FORM NO. EN-31022-16-M370-1(81)  
DRA 108  
SIZE CODE **A** NUMBER **MF20-8-8** REV **B**  
SHEET **26** OF **62**

**ENGINEERING SPECIFICATION** **MF20** Installation Procedure CONTINUATION SHEET

TITLE	MF20 Installation Procedure
8.19	Install the MF20 logic assembly to the horizontal mounting bars with screws (item #4), lock washers (item #5) and kep nuts (item #7), two screws and lock washers for each corner except the lower left hand corner as seen in drawing E-UA-MF20-8-8 sheet #2. (You may need 2 people for this step). NOTE: MF20 #1 (MF20LA or MF20LB) will always be mounted on the hinge side of the equipment mounting door.
8.20	Replace the intake bezel on the MF20 housing.
8.21	Secure the lower left hand corner of the MF20 with screw (item #4) and two (2) lock washers (item #6) also securing one end of the ground strap (item #8). Installation should be such that the screw goes through one lock washer then the ground strap then the second lock washer then the mounting bar.
8.22	Secure the other end of the ground strap to the mounting rail at hole #14 with a screw (item #4), two (2) lock washers (item #6), and a kep nut (item #7) as seen in print E-UA-MF20-8-8 sheet #2.
8.23	If removed above, replace the rear door locking bracket on the I/O cabinet rear equipment mounting door.

DEC FORM NO. EN-31022-16-M370-1(81)  
DRA 108  
SIZE CODE **A** NUMBER **MF20-8-8** REV **B**  
SHEET **27** OF **62** MK

**ENGINEERING SPECIFICATION** **MF20** Installation Procedure CONTINUATION SHEET

TITLE	MF20 Installation Procedure
8.24	Replace external cabinet doors removed in step 8.2 above. Also; cut the foam on the rear doors so as not to block the air ducts which contain their own filter.
8.25	Replace the orange front top panel (grill) on the I/O bay.
8.26	Proceed to section 18.8 for cabling of unit.
9.0	<b>MF20 #2 MOUNTING PROCEDURE</b> Perform skidded checkout section 6.6 before proceeding with this section, by unplugging the X-BUS cable board from MF20 #1 and replacing it with the 13 ft. X-BUS cable board for the skidded checkout.
9.1	Disconnect DC and sense harnesses from the MF20 back plane.
9.2	Check to see that the CPU cabinet rear equipment mounting door has tinnerman nuts (item #2) in holes #19, 21, 28 and 38 as seen in drawing E-UA-MF20-8-8 sheet #2, if not add them.

DEC FORM NO. EN-31022-16-M370-1(81)  
DRA 108  
SIZE CODE **A** NUMBER **MF20-8-8** REV **B**  
SHEET **28** OF **62**

ENGINEERING SPECIFICATION		CONTINUATION SHEET	
MP20 Installation Procedure			
TITLE	SIZE CODE	NUMBER	REV
	A	MP20-0-2	B
9.3			
Remove mounting screws securing the power supply to the shipping skid and set it aside.			
9.4			
Remove the power supply mounting bracket from the shipping skid.			
9.5			
Install the power supply mounting bracket on the CPU cabinet rear equipment mounting door using screws (item 4) and lock washers (item 5) as seen in print E-UA-MF20-0-0 sheet #3 (view section A-A).			
9.6			
Install the power supply in the CPU cabinet rear equipment mounting door above the MF20 #1 power supply using screws (item 4) and lock washers (item 5) as seen in print E-UA-MF20-0-0 sheet #2.			
9.7			
Remove the Battery Box from the shipping skid.			
9.8			
Install the battery box in the CPU cabinet rear equipment mounting door as seen in print E-UA-MF20-0-0 sheet #2 using screws (item 4) and lock washers (item 5).			

DEC FORM NO EN-01022-10-N370-1011  
DRA 108

SHEET 29 OF 62

ENGINEERING SPECIFICATION		CONTINUATION SHEET	
MP20 Installation Procedure			
TITLE	SIZE CODE	NUMBER	REV
	A	MP20-0-2	E
9.3			
Remove mounting screws securing the power supply to the shipping skid and set it aside.			
9.4			
Remove the power supply mounting bracket from the shipping skid.			
9.5			
Install the power supply mounting bracket on the CPU cabinet rear equipment mounting door using screws (item 4) and lock washers (item 5) as seen in print E-UA-MF20-0-0 sheet #3 (view section A-A).			
9.6			
Install the power supply in the CPU cabinet rear equipment mounting door above the MF20 #1 power supply using screws (item 4) and lock washers (item 5) as seen in print E-UA-MF20-0-0 sheet #2.			
9.7			
Remove the Battery Box from the shipping skid.			
9.8			
Install the battery box in the CPU cabinet rear equipment mounting door as seen in print E-UA-MF20-0-0 sheet #2 using screws (item 4) and lock washers (item 5).			

DEC FORM NO DEC 16-(081)-1022-N370  
DRA 108

SHEET 30 OF 62

ENGINEERING SPECIFICATION		CONTINUATION SHEET	
MP20 Installation Procedure			
TITLE	SIZE CODE	NUMBER	REV
	A	MP20-0-2	B
9.9			
Close CPU cabinet rear doors and open I/O cabinet rear doors.			
9.10			
Remove the mounting screws securing the MF20 logic to the horizontal mounting bars of the shipping skid.			
9.11			
Remove the intake bezel from the MF20 housing.			
9.12			
Install the MF20 logic in the I/O cabinet rear equipment mounting door next to mem unit #1 securing it at three (3) corners with screws (item 4) and washers (item 5) and keep nuts (item #7) as seen in drawing E-UA-MF20-0-0 sheet #2. Do not secure lower right hand corner.			
9.13			
Replace the intake bezel on the MF20 housing.			
9.14			
Secure the lower right hand corner of the MF20 with a screw (item 4) and two (2) lock washers (item 6) also securing one end of the ground strap (item 8). Installation should be such that the screw goes through one lock washer then through the ground strap then the second lock washer then the mounting bar.			

DEC FORM NO DEC 16-(081)-1022-N370  
DRA 108

SHEET 31 OF 62

ENGINEERING SPECIFICATION		CONTINUATION SHEET	
MP20 Installation Procedure			
TITLE	SIZE CODE	NUMBER	REV
	A	MP20-0-2	E
9.15			
Secure the other end of the ground strap to the mounting rail at hole #14 with a screw (item 4), two (2) lock washers (item 6) and keep nut (item 7) as seen in print E-UA-MF20-0-0 sheet #2.			
9.16			
Proceed to section 10.2 for cabling of unit.			
10.0 CABLING AND WIRING PROCEDURE			
10.1			
FOR MP20 #1			
NOTE: All cables and harnesses to be routed as seen on SHEETS 4,5 & 6 OF PRINT E-UA-MF20-0-0			
10.1.1 Connect the D.C. power harness #1 (7015071-0-0) to the MF20 back plane at terminal strips along the top and bottom as seen in chart #1 on sheet #6 of print E-UA-MF20-0-0. (Reference drawing D-IC-MF20-0-3 also)			
10.1.2 Connect the Master Oscillator DC power harness (7015471-0-0) to the Master Oscillator by the 8 pin mat-n-lock. Connect the yellow and black twisted pair to the H778 in the H7428 and the orange and black twisted pair to the MF20 backplane as seen in chart #13 on sheet 6 of print E-UA-MF20-0-0. Use tie wraps (item #9) to tie off the orange and black twisted pair for MF20 #2. (After taping ends with electrical tape).			

DEC FORM NO DEC 16-(081)-1022-N370  
DRA 108

SHEET 32 OF 62

**ENGINEERING SPECIFICATION** CONTINUATION SHEET

TITLE MF20 Installation Procedure

- 10.1.1.3 Connect the Master Oscillator Clock select cable (701524-0-0) to the M8572 X-BUS cable board (3 ft. 8 in. long) as seen in chart #4 on sheet 4 of print E-UA-MF20-0-0.
- 10.1.1.4 Plug the X-BUS cable board (M8572) into slot 2 of the CPU. Plug the other ends into MF20 backplane (top to connector just below L.E.D, bottom to bottom, etc.)
- 10.1.1.5 Connect the Clock Coax Cable (1700100-0) to the external clock connector below slot 9 of the CPU backplane. Connect the other end to the Master Oscillator. Also, connect coax cable to MF20 from Master Oscillator (see chart #5 SHEET 4 OF PRINT E-UA-MF20-0-0).
- 10.1.1.6 Connect the Margin Sense Cable (7015190-0-0) to the connector on the MF20 backplane as seen in chart #9 on sheet 6 of print E-UA-MF20-0-0.
- 10.1.1.7 Connect the Master Oscillator A.C. Power harness (7015448-0-0) to the Master Oscillator and to the MF20 power supply as seen in chart #3 on sheet #5 of print E-UA-MF20-0-0.
- 10.1.1.8 Connect the MF20 AC power harness (7015222-0-0) from the MF20 power supply to the MF20 fans as seen in chart #11 on sheet 5 of print E-UA-MF20-0-0.
- 10.1.1.9 Plug the AC power cord into an extension and into the 063 power control in location 324.
- 10.1.10 Plug Door Switch Interlock Harness (7015453-0-0) on to the door switch and connect to the fault harness as seen in chart #19 on sheet 6 of print E-UA-MF20-0-0.

DEC FORM NO DEC 16-(1981)-1022-N370  
DRA 108

SIZE CODE NUMBER REV  
A SP MF20-0-2 B

SHEET 33 OF 62 MR

**ENGINEERING SPECIFICATION** CONTINUATION SHEET

TITLE MF20 Installation Procedure

- 10.1.1.11 Plug the Vane Switch Harness (7015447-0-0) on to the vane switches and connect to the fault harness as seen in chart #7 on sheet 6 of print E-UA-MF20-0-0.
- 10.1.1.12 Plug in the Battery Box Harness (7015223-0-0) in to the MF20 power supply, but do not turn them on at this time.
- 10.1.1.13 Connect the DEC remote power bus (7008288-15) from power supply to rear of switch panel drawing E-UA-MF20-0-0 sheet 7 chart #21.
- 10.1.1.14 Proceed to section 12.0 for preliminary electrical checkout.
- 10.2  
FOR MF20 #2
- NOTE: All cables and harnesses to be routed as seen on SHEETS 7,8,9 OF PRINT E-UA-MF20-0-0.
- 10.2.1 Connect the DC Power Harness for MF20 #2 (7015180) to the terminal strips along the top and bottom of the MF20 backplane as seen in chart #2 on sheet 7 of print E-UA-MF20-0-0.
- 10.2.2 Cut tie wraps to free the end of the Master Oscillator DC Power Harness and connect it to the MF20 backplane as seen in chart #14 on sheet 9 of print E-UA-MF20-0-0.

DEC FORM NO DEC 16-(1981)-1022-N370  
DRA 108

SIZE CODE NUMBER REV  
A SP MF20-0-2 B

SHEET 34 OF 62

**ENGINEERING SPECIFICATION** CONTINUATION SHEET

TITLE MF20 Installation Procedure

- 10.2.3 Remove the X-BUS terminators from MF20 #1 and relocate them on MF20 #2.
- 10.2.4 Install the 1 foot X-BUS jumper between MF20 #1 and MF20 #2.
- 10.2.5 Install the AC Power Harness between the MF20 #2 fans and the MF20 #2 power supply.
- 10.2.6 Plug the AC power cord into an extension cord and into the 063 power control in location J26.
- 10.2.7 Cut tie wraps necessary to free up section of Door Switch Interlock Harness and plug into MF20 #2 door switch.
- 10.2.8 Cut tie wraps necessary to free up section of Vane Switch Harness and plug in vane switches for MF20 #2.
- 10.2.9 Plug the Battery Box Harness into the MF20 #2 power supply, but do not turn it on at this time.
- 10.2.10 Connect DEC power bus cable (7008288-3P) from P/S #1 to P/S #2 per drawing E-UA-MF20-0-0, chart #22, SHEET #6.
- 10.2.11 Connect clock coax from backplane to master oscillator per drawing E-UA-MF20-0-0, chart #6, SHEET #4.
- 10.2.12 Proceed to section 12.0 for preliminary electrical checkout.

DEC FORM NO DEC 16-(1981)-1022-N370  
DRA 108

SIZE CODE NUMBER REV  
A SP MF20-0-2 B

SHEET 35 OF 62 MR

**ENGINEERING SPECIFICATION** CONTINUATION SHEET

TITLE MF20 Installation Procedure

- 11.0 MF20 EXTERNAL CABINET ADD-ON
- 11.1  
Pre-installation check-out
- 11.1.1 Remove end panel from the right hand side (CPU cabinet) of the system. (Top cover must be removed first.)
- 11.1.2 Roll cabinet up to the system where the end panel was removed. Remove the gray back doors from the external cabinet and the left rear door from the CPU cabinet.
- 11.1.3 Attach the ground strap located on external cabinet to the system using the hardware that held the ground strap from the end panel, and the stud adjacent to the stud it is already attached to. (There may not be a stud present in this location on older cabinets, but there will be an available stud or hole where it can be attached nearby.)
- 11.1.4 See drawing D-UA-MF20-0-0 SHEETS 4-9 for routing of cables to be hooked up. Do not tie the cables down at this point.
- 11.1.5 There is a total of 8 cables to be hooked up, but before this can be done, the MA/MB20 (located under the CPU) must be disconnected.
- 11.1.6 To disconnect the MA/MB20:

DEC FORM NO DEC 16-(1981)-1022-N370  
DRA 108

SIZE CODE NUMBER REV  
A SP MF20-0-2 B

SHEET 36 OF 62 MR

ENGINEERING SPECIFICATION		CONTINUATION SHEET	
MF20 Installation Procedure			
11.1.6.1	Unplug the H7420 power supplies from their extension cords located at the bottom of the CPU cabinet.	SIZE CODE	NUMBER
11.1.6.2	Unplug the vane switch harness from its location at the bottom of the MA/MB20.	A SP	MF20-0-2
11.1.6.3	Unplug the door switch interlock cable also at the bottom of the MA/MB20.		
11.1.6.4	Unplug the S-bus cables from slot 3 of the CPU backplane.		
11.1.6.5	Replace the two M8580 modules with the two M8581 modules. (Slots 7 & 8, CPU backplane.)		
11.1.7	The 8 cables that have to be connected are:		
11.1.7.1	The A.C. power cord from the power supply (this will plug into the extension cord that the MA/MB20 power supply was plugged into.) Chart #35, SHEET #4.		
11.1.7.2	The vane switch harness (this will plug into the MA/MB20 vane switch harness). CHART #25, SHEET #6. (HARNESS P/N 7816211-0-0 BLK, ORN, YEL)		
11.1.7.3	The door switch interlock harness (this will also plug into the MA/MB20 fault harness) Chart #39, SHEET #6. (HARNESS P/N 7816212-0-0 BLU, BLK)		

DEC FORM NO DEC 16-(381)-1022-N370  
DRA 108

SIZE CODE A SP NUMBER MF20-0-2 REV B  
SHEET 37 OF 62 MR

ENGINEERING SPECIFICATION		CONTINUATION SHEET	
MF20 Installation Procedure			
11.1.8.2	Power down the MF20 and plug all of the modules back in and power it back up.	SIZE CODE	NUMBER
11.1.8.3	Check the voltages at the MF20 backplane again as above only this time should be + or - 2%.		
11.1.8.4	Check S-BUS "VREF" by placing D.V.M. on pin F5A1 on MF20 it should read +1.40 +/- .02 volts. If "VREF" is not within spec, replace M8580 or M8581 in slot 7 of CPU. (If new module is not available, swap modules in slots 7 & 8, to obtain same results. "Check VREF" on pin F5D1. If it is bad, replace the M8576 board.		
11.1.8.5	Check the X-BUS sync with a scope using the following quick check. Boot strap load KLDCP. Set X-BUS sync as follows: NOTE: The nominal setting of the 2 switches on the M8576 for XBUS deskew ADJ. is as follows: 13 ft. XBUS cable: turn each switch all the way clockwise and back off 1 click. 3 ft. 8 in. XBUS cable: turn each switch all the way clockwise and back off 2 clicks.		
11.1.8.6	Set scope to 1V/DIV for both chan 1 and chan 2. Set sweep rate to 20NS/C/DIV. Load the KL18 microcode. Select full clock rate and source the clock from the master oscillator at 30MHZ. Start the microcode, (CR9, PW72/3, CS2, SN).		
11.1.8.7	Place probe 1 on pin E22P2 in the CPU bay (signal "A change coming L") and place the clip on a ground pin. Place probe 2 on pin D5D1 in MF20 (signal "CTL2 A PHS COM FREE L") and place the clip on a ground pin. Synchronize internal on chan 1. These signals must be identical.		

DEC FORM NO DEC 16-(381)-1022-N370  
DRA 108

SIZE CODE A SP NUMBER MF20-0-2 REV B  
SHEET 39 OF 62 MR

ENGINEERING SPECIFICATION		CONTINUATION SHEET	
MF20 Installation Procedure			
11.1.7.4	The black coax cable from the backplane will plug into the Master Oscillator. Chart #27, SHEET #8.	SIZE CODE	NUMBER
11.1.7.5	The remote turn on cable will go from the MF20 power supply to the top power supply of the internal MF20. (HARNESS P/N 7808288-15-0 GRAY) Chart #41, SHEET #9.	A SP	MF20-0-2
11.1.7.6	The black and orange cable will go from the MF20 backplane terminal strip to the Master Oscillator. Chart #33, SHEET #7. (HARNESS P/N 7816207-0-0)		
11.1.7.7	The A.C. power harness from the 2 cab flushing fans will plug into both halves of the connection for 2 cab flushing fans located in the CPU cabinet. (HARNESS P/N 7816210-0-0 RED, WHT) (This connection is located at the same place that the MA/MB power supplies should have been disconnected.) CHART #34, SHEET #7. (The flushing fans must be checked to see if they are operating after power up.)		
11.1.7.8	The X-BUS cable board (M8572-YA) will go from the CPU backplane to the MF20 backplane. (NOTE: The exact location of the cable connections will appear in drawing D-UA-MF20-0-0 sheet 5.		
11.1.8	After all the cable connections are made, open the MF20 rear door and slide all the modules out about one inch so that there will be no electrical connection. Replace CPU rear door and put system in over-ride. Power up system.		
11.1.8.1	Check the power supply voltages at the MF20 backplane terminal block (from left to right) -2V, gnd, -5.2V, gnd, +5V, gnd, +12V, gnd, +12V and gnd. Voltages should be + or - 1% at this point.		

DEC FORM NO DEC 16-(381)-1022-N370  
DRA 108

SIZE CODE A SP NUMBER MF20-0-2 REV B  
SHEET 38 OF 62

ENGINEERING SPECIFICATION		CONTINUATION SHEET	
MF20 Installation Procedure			
11.1.8.8	Move probe 1 from CPU bay to MF20 at pin C5M2 (signal "CTL2 B PHS COM FREE L") and place the clip on a ground pin. Set the scope to add channel 1 with channel 2. The waveform observed must be perfectly symmetrical with respect to on/off time.	SIZE CODE	NUMBER
11.1.8.9	If the sync does not check the XBUS must be synchronized by following drawing A-SP-MF20-SYNC. If the sync does check, then proceed.	A SP	MF20-0-2
11.1.8.10	Run diagnostics DHEXA.All & DRNDP.All.		
11.1.8.11	Power system down. At this point the pre-installation checkout is complete.		
11.1.9	At this point you have 2 choices of what to do next.		
11.1.9.1	If you are going to proceed with the installation of the MF20, complete the rest of this section. (11.0)		
11.1.9.2	If for some reason you are not going to proceed, follow this section in reverse to get the system back to the condition it was in before you started.		
11.1.10	Removal Of MA/MB20 (if Necessary) . -		
11.1.10.1	Power the system down.		

DEC FORM NO DEC 16-(381)-1022-N370  
DRA 108

SIZE CODE A SP NUMBER MF20-0-2 REV B  
SHEET 40 OF 62

ENGINEERING SPECIFICATION		CONTINUATION SHEET	
TITLE		MP20 Installation Procedure	
11.1.10.2 Disconnect the A.C. power to the blower on top of the cooling assembly, (red and white twp), and cut the tie wraps all the way back to the power supplies.			
11.1.10.3 Disconnect the d.c. power harness at both ends, cut the tie wraps and remove the harness.			
11.1.10.4 Remove the sbus cables going from the MA/MP20 to the CPU.			
11.1.10.5 Remove the eight screws holding the MA/MP20 in place, and remove the memory assembly. (This is a 2 person job).			
11.1.10.6 Remove the hardware holding the 2 H7426 power supplies and remove them also. (two people if necessary.)			
11.2 Installation of the external MP20 cabinet.			
11.2.1 All there is to hooking up the external MP20 cabinet is bolting the cabs together, and making all the connections made in paragraph 11.1.7 permanent. To do this, you must first install the cable routing basket and the cable basket mounting brackets. See drawing D-UA-MP20-0-9 sheet 6. (section F-F) The 4 holes needed to mount brackets may have to be punched out if you have an older cabinet. If so, locations of these holes can be found in figure 3. The holes must be punched with a Roper Whitney No. 5 jr. punchset (1/4 in. size bit) or equivalent.			
NOTE: Removal of the X-BUS cables and the black coax cables is necessary for the installation of the basket and brackets.			
DEC FORM NO DEC 16 (381)-1022-N370 DPA 105		REV B	
SIZE CODE A SP		NUMBER MP20-0-2	
SHEET 41 OF 62		ML	

ENGINEERING SPECIFICATION		CONTINUATION SHEET	
TITLE		MP20 Installation Procedure	
11.2.2 Remove the two filler strips (D-IA-7011836-0-0) front and back, and the filler strip (top) D-MD-7414403-0-0, to allow the bolting together of the two cabinet assemblies.			
11.2.3 Bolt the two cabinet assemblies together using the six bolts P/N 9006241-09 and the six kepnuts P/N 9008203 (supplied with the cabinet assy. These must be removed from the cabinet assy then replaced after the cabinets are rolled together.) NOTE: It may be helpful to use the leveler feet to get the holes to line up.			
11.2.4 Put the three filler strips back in place after bolting the two cabinets together, using existing screws and washers plus 6 screws (9006071-03) and 6 washers (9007651) supplied with the installation kit. See drawing E-AD-7016035-0-0 section "F" for installing the filler strips.			
NOTE: The top covers must be removed on the MP20 and CPU cabinets before the top filler strip can be installed.			
While the top cover is still off the ext cabinet place the end panel removed from the DECSYSTEM-20 on the end of the ext cab using the hardware that was holding it on the DECSYSTEM-20. Also, attach the ground strap from the end panel to the ext cab gnd stud with items 12 & 13.			
11.2.5 Replace the X-BUS and coax cables but run them through the strain relief assy on the side of the CPU card cage and up through the cable routing basket first.			
11.2.6 Tie all the cables down per drawing D-UA-MP20-0-9 SHEETS 4-9, USING tie wraps item 8 (9007000) and item 10 (9007032), wherever necessary.			
11.2.7 Take the end panel and it's hardware and move it to the end of the MP20 cabinet.			
DEC FORM NO DEC 16 (381)-1022-N370 DPA 105		REV B	
SIZE CODE A SP		NUMBER MP20-0-2	
SHEET 42 OF 62			

ENGINEERING SPECIFICATION		CONTINUATION SHEET	
TITLE		MP20 Installation Procedure	
11.3 Installation of second box of MP20 in external cabinet.			
11.3.1 This assembly will come to you on a shipping skid just like the internal MP20 did. Because it will not be replacing an existing memory, and the difficulty of giving this memory a skidded checkout, it will be installed and then checked-out.			
11.3.2 To install the second memory:			
11.3.2.1 Disconnect DC and sense harnesses from the MP20 backplane.			
11.3.2.2 Check to see that the external MP20 cabinet rear equipment mounting door has tinnerman nuts (item #2) in holes #19, 21, 28 and 30 as seen in drawing E-UA-MP20-0-9 sheet #2, if not add them.			
11.3.2.3 Remove mounting screws securing the power supply to the shipping skid and set it aside.			
11.3.2.4 Remove the power supply mounting bracket from the shipping skid.			
11.3.2.5 Install the power supply mounting bracket on the external MP20 rear equipment mounting door using screws (item #4) and lock washers (item #5) as seen in print E-UA-MP20-0-9 sheet #3 (view section A-A).			
DEC FORM NO DEC 16 (381)-1022-N370 DPA 105		REV B	
SIZE CODE A SP		NUMBER MP20-0-2	
SHEET 43 OF 62		ML	

ENGINEERING SPECIFICATION		CONTINUATION SHEET	
TITLE		MP20 Installation Procedure	
11.3.2.6 Install the power supply on the external MP20 cabinet rear equipment mounting door above the MP20 #1 power supply using screws (item #3) and lock washers (item #5) as seen in print E-UA-MP20-0-9 sheet #2.			
11.3.2.7 Remove the Battery Box from the shipping skid.			
11.3.2.8 Install the battery box on the external MP20 cabinet rear equipment mounting door as seen in print E-UA-MP20-0-9 sheet #2 using screws (item #4) and lock washers (item #5).			
11.3.2.9 Remove the mounting screws securing the MP20 logic to the horizontal mounting bars of the shipping skid.			
11.3.2.10 Install the MP20 logic in the external MP20 next to mem unit #1 securing it at three (3) corners with screws (item #4) and washers (item #5) and kep nuts (item #7) as seen in drawing E-UA-MP20-0-9 sheet #2. Do not secure lower right hand corner.			
11.3.2.11 Secure the lower right hand corner of the MP20 with a screw (item #4) and two (2) lock washers (item #6) also securing one end of the ground strap (item #8). Installation should be such that the screw goes through the ground strap then the second lock washer then the mounting bar.			
11.3.2.12 Secure the other end of the ground strap to the mounting rail at hole #48 with a screw (item #4) two (2) lock washers (item #6) and kep nut (item #7) as seen in print E-UA-MP20-0-9 sheet #11.			
DEC FORM NO DEC 16 (381)-1022-N370 DPA 105		REV B	
SIZE CODE A SP		NUMBER MP20-0-2	
SHEET 44 OF 62			

ENGINEERING SPECIFICATION		CONTINUATION SHEET	
TITLE MF20 Installation Procedure		REV B	
11.3.3 Cabling: The cables to be hooked up are:		SIZE CODE A SP	
11.3.3.1 The 1 foot X-bus jumper cables must be installed between MF20 #1 and #2 (remove terminators from #1 and replace them in #2).		NUMBER MF20-0-2	
11.3.3.2 Take section of door switch interlock cable left from MF20 #1 installation and hook it up to MF20 #2 per drawing E-UA-MF20-0-0 sheet 6, chart #40.		SHEET 15 OF 62	
11.3.3.3 Take the section of the vane switch harness left over from MF20 #1 installation and hook it up to MF20 #2 vane switches per chart #26, SHEET #6.		DEC FORM NO DEC 16-(1011)-1022-N370 DRA 108	
11.3.3.4 Hook up the coax cable from the MF20 #2 backplane to the master oscillator per chart #28, SHEET #8.			
11.3.3.5 Hook up the A.C. power to the MF20 fans from the P/S per chart #32, SHEET #7. (RED/WHITE)			
11.3.3.6 Hook the remote cable jumper between the two power supplies per chart #42, SHEET #9.			
11.3.3.7 Hook up the D.C. power harness from the power supply to the backplane per chart #24, SHEET #4.			
11.3.3.8 Hook up the margin sense harness from the power supply to the backplane per chart #30, SHEET #8.			

ENGINEERING SPECIFICATION		CONTINUATION SHEET	
TITLE MF20 Installation Procedure		REV B	
11.3.3.9 The A.C. power cord from P/S chart #36, SHEET #4.		SIZE CODE A SP	
11.3.3.10 The battery back-up harness (7011523-0-0).		NUMBER MF20-0-2	
NOTE: Routing of these cables is described in drawing E-UA-MF20-0-0, SHEETS 4-9.		SHEET 16 OF 62	
12.0 PRELIMINARY ELECTRICAL CHECKOUT		DEC FORM NO DEC 16-(1011)-1022-N370 DRA 108	
12.1			
Open memory logic doors and unplug all modules and pull them out about 1 inch so that no electrical connection is made.			
12.2			
Power up the MF20 and check voltages at terminal strip along the top of the backplane (from left to right) -2V, gnd, -5.2V, gnd, -5.2V, gnd, +5V, gnd, +12V, gnd, +5V, gnd, +12V, gnd. Voltages should be + or - 10% at this point.			
12.3			
Power down the MF20 and plug all the modules back in and power it up again.			
12.4			
Check voltages again as above. At this point voltages should be + or - 2%.			

ENGINEERING SPECIFICATION		CONTINUATION SHEET	
TITLE MF20 Installation Procedure		REV B	
12.5		SIZE CODE A SP	
Check "VREF" to be +1.40 +/- .02 volts at pin F05D1 of the MF20 backplane.		NUMBER MF20-0-2	
12.6		SHEET 17 OF 62	
X-BUS clock sync must now be adjusted per drawing A-SP-MF20-SYNC.		DEC FORM NO DEC 16-(1011)-1022-N370 DRA 108	
12.6.1 Check The Function Of The Vane Switches As Follows: -			
12.6.1.1 Disconnect the AC from one fan (with system down) on the MF20 cooling assy.			
12.6.1.2 Power system back up			
12.6.1.3 System should shut down within 30 seconds with an "airflow MEM 1" fault for external MF20 and an "airflow MEM 2" fault for internal memory.			
12.6.1.4 Repeat steps 12.6.3.1 - 12.6.3.3 for each of the MF20 cooling assy fans			
12.6.1.5 Be sure to replace the A.C. wires when you are through.			
12.6.2 Turn on all battery back-up.			

ENGINEERING SPECIFICATION		CONTINUATION SHEET	
TITLE MF20 Installation Procedure		REV B	
13.0 CHECKOUT AND ACCEPTANCE PROCEDURE		SIZE CODE A SP	
A-SP-MF20-FATP shall be performed and the system shall meet the "biannual criteria" contained within the document.		NUMBER MF20-0-2	
		SHEET 18 OF 62	
		DEC FORM NO DEC 16-(1011)-1022-N370 DRA 108	

ENGINEERING SPECIFICATION		CONTINUATION SHEET	
TITLE MF20 INSTALLATION PROCEDURE			
DEC FORM NO. EN-01022-16-N7074-1381 DRA 108			
SHEET 49 OF 62			
REV	SIZE	CODE	NUMBER
B	A	SP	MF20-0-2
14.1.1			
14.1.1.1			
14.1.1.2			
14.1.1.3			
14.1.1.4			
14.1.1.5			
14.1.1.5.1			
14.1.1.6			
14.1.1.6.1			
14.1.1.6.2			
14.1.1.7.1			
14.1.1.7.2			
14.1.1.7.3			
14.1.1.7.4			
14.1.1.7.5			
14.1.1.7.6			
14.1.1.7.7			
14.1.1.7.8			

ENGINEERING SPECIFICATION		CONTINUATION SHEET	
TITLE MF20 INSTALLATION PROCEDURE			
DEC FORM NO. EN-01022-16-N7074-1381 DRA 108			
SHEET 50 OF 62			
REV	SIZE	CODE	NUMBER
B	A	SP	MF20-0-2
14.1.6.3			
14.1.6.4			
14.1.6.5			
14.1.6.6			
14.1.6.7			
14.1.6.8			
14.1.6.9			
14.1.6.10			
14.1.6.11			
14.1.6.12			
14.1.7			
14.1.7.1			
14.1.7.1.1			
14.1.7.1.2			
14.1.7.1.3			
14.1.7.1.8			
14.1.7.1.8.1			
14.2			
14.2.1			
14.2.2			

ENGINEERING SPECIFICATION		CONTINUATION SHEET	
TITLE MF20 INSTALLATION PROCEDURE			
DEC FORM NO. EN-01022-16-N7074-1381 DRA 108			
SHEET 51 OF 62			
REV	SIZE	CODE	NUMBER
B	A	SP	MF20-0-2
14.1.7.1			
14.1.7.2			
14.1.7.3			
14.1.7.4			
14.1.7.5			
14.1.7.6			
14.1.7.7			
14.1.7.8			

ENGINEERING SPECIFICATION		CONTINUATION SHEET	
TITLE MF20 INSTALLATION PROCEDURE			
DEC FORM NO. EN-01022-16-N7074-1381 DRA 108			
SHEET 52 OF 62			
REV	SIZE	CODE	NUMBER
B	A	SP	MF20-0-2
14.1.7.9			
14.1.7.10			
14.1.7.11			
14.1.7.12			
14.1.7.13			
14.1.8			
14.1.8.1			
14.2			
14.2.1			
14.2.2			

ENGINEERING SPECIFICATION		CONTINUATION SHEET
TITLE MF20 INSTALLATION PROCEDURE		
14.2.3	Bolt the two cabinet assemblies together using the six bolts P/N 9086241-99 and the six kephnuts P/N 9088203 (supplied with the cabinet assy). These must be removed from the cabinet assy and replaced after the cabinets are pushed together.  Note: It may be helpful to use the leveler feet to get the holes to line up.	
14.2.4	Put the three filler strips back in place after bolting the two cabinets together, using existing screws and washers plus six screws (9086071-83) and six washers (9087651) supplied with the installation kit. See drawing E-AD-7816635-8-8 section "1" for installing the filler strips.	
14.2.5	While the top cover is still off of the external cabinet put the end panel and its hardware from the Dec System 28 onto the external cabinet. Also attach the ground strap from the end panel to the external cabinet using items 12 & 13.	
14.2.6	Replace the X-Bus and coax cables but run them through the strain relief assembly on the side of the CPU card cage and up through the wire basket first.	
14.2.7	Tie all the cables down per drawing D-UA-MF28-8-8 sheets 4-9, using tie wraps, item 8 P/N 9087889, and tie wraps, item 18 P/N 9087832, wherever necessary.	
15.0	PROCEED BACK TO SECTION 12.8 FOR ELECTRICAL CHECKOUT, AND 13.8 FOR CHECKOUT AND ACCEPTANCE.	
15.1	Internal memory (MF28-LU/LV only).	
15.1	Before proceeding with this section, sections 1-5 should be read and any prior work should be done according to such sections.	
15.2	A pre-installation check-out should be performed before the MF28 is actually installed.	
15.2.1	Power down the system.	
15.2.2	Place the shipping skid with the MF28 on it next to the system as close to the rear of the I/O cabinet as possible (with the I/O bays doors removed).	
15.2.3	Replace the M859's in slots 7 & 8 of the CPU backplane with M8591's supplied with the MF28-LU/LV.	

DEC FORM NO EN-01022-16-N170-1(81)  
DRA 108

SIZE CODE NUMBER  
A SP MF20-0-2

SHEET 53 OF 52

ENGINEERING SPECIFICATION		CONTINUATION SHEET
TITLE MF20 INSTALLATION PROCEDURE		
15.2.4	Remove the BC28V-89 board in slot 3 of CPU.	
15.2.5	Move 13 ft X-Bus board from slot 2 to slot 3 of CPU so that the 13 ft X-Bus cable board supplied to test the skidded MF28 can go into slot 2. Also remove the clock select cable from the 13 ft X Bus board in the system and install onto the new 13 ft one.	
15.2.6	Insert the X-Bus cable board from the skid into slot 2 of the CPU.	
15.2.7	Plug the other end of the X-Bus cable board into the MF28 backplane on the skid. (Bottom cable to bottom connector, top to top etc. as they come out of the CPU.)	
15.2.8	Place the strain relief assembly over the cables coming out of the CPU and clamp them in.	
15.2.9	See drawing D-UA-MF28-8-8 sheets 4-9 and temporarily hook up all the cables so you can perform the skidded checkout.	
15.2.10	The only cables in this case that have to be hooked up are the coax cable from the master osc. to the MF28 backplane, the ac power cord which plugs into one of the extension cords from the existing MB28 on the back door of the I/O cabinet, the door switch and vane switch harnesses which also plug into the existing cabling of the MB28, and +12V supply to the master oscillator. Note: Before hooking up these cables disconnect the MB28's ac to the blowers, fault wiring, and power supply ac lines.	
15.2.11	Hook up the remote turn on cable from the MF28 power supply (J2) to the upper power supply of the external MF28 cabinet (J3) per harness chart #41.	
15.2.12	Open the MF28 rear card cage door and slide all the modules out about 1 inch so that there is no electrical connection between the MF28 and the module.	
15.2.13	Power up the system and power on the MF28 power supply.	
15.2.14	Check the voltages on the MF28 terminal block (from left to right) -2V gnd, -5.2V, gnd, -5.2V, gnd, +5V, gnd, +12V, gnd, +3V, gnd, +12V and gnd. Voltages should be + or - 1% at this point.	

DEC FORM NO EN-01022-16-N170-1(81)  
DRA 108

SIZE CODE NUMBER  
A SP MF20-0-2

SHEET 54 OF 52

ENGINEERING SPECIFICATION		CONTINUATION SHEET
TITLE MF20 INSTALLATION PROCEDURE		
15.2.15	Power down the MF28, plug all the modules back in and power it back-up again.	
15.2.16	Check the voltages again. They should be + or -2% at this time.	
15.2.17	Check the S-Bus "VREF" by placing a D.V.M. on pin F85A1 of the MF28. It should read +1.48 volts + or -8.2V. If the "VREF" is not within spec, replace the M8591 board in slot 7 of CPU backplanes. If a new board is not available, swap the M8591's in slots 7 & 8 to obtain the same results. Also check "VREF" on MF28 pin F85D1. If this is bad, replace the M8576 module.	
15.2.18	Check the X-Bus clock sync with a scope using the following procedure: Boot strap load KLDCP Set X-bus sync as follows: 13 ft (M8572) cable, turn each switch all the way clockwise and back off 1 click. 3 ft 8 in (M8572) cable, turn each switch all the way clockwise and back off 2 clicks.	
15.2.19	Set the scope to 1V/DIV for both channel 1 & 2. Set the sweep rate to 20N SEC/DIV. Load the KL18 microcode. Select the full clock rate and source the clock from the master oscillator at 38 MHz. Start the microcode. (CRO, PW72/3, CS2, SM)	
15.2.20	Place probe 1 on pin E22F2 in the CPU bay and place the clip on a ground pin. Place probe 2 on pin D85D1 of the MF28 and place that ground clip on a ground pin also. Synchronize internal on channel 1. These signals must be identical.	
15.2.21	Move probe 1 from the CPU to pin C85M2 of the MF28 and place the clip on a ground pin. Set the scope to add channel 1 with channel 2. The waveform observed must be perfectly symmetrical with respect to on/off time.	
15.2.22	If the sync does not check, the X-Bus must be synchronized by following drawing A-8P-MF28-8-50MC. If the sync does check, proceed.	
15.2.23	Run diagnostics DKBA.A11 & DKRBF.A11	
15.2.24	Power down the system. At this point the skidded checkout is complete and it should be determined	

DEC FORM NO EN-01022-16-N170-1(81)  
DRA 108

SIZE CODE NUMBER  
A SP MF20-0-2

SHEET 55 OF 52

ENGINEERING SPECIFICATION		CONTINUATION SHEET
TITLE MF20 INSTALLATION PROCEDURE		
15.2.25	If you are going to proceed with the installation and a rear door MA/MB28 is to be removed, complete section 7.8 before continuing this section.	
15.2.26	If you are going to proceed with the installation of the MF28 and there is no MA/MB28 to be removed, proceed with the rest of this section.	
15.2.27	If you are going to abort the installation for any reason, perform this section in reverse to get the system back into the same condition it was in when you began.	
15.2.28	Unplug the X-bus cable (M8572) from the CPU.	
15.2.28.1	Disconnect the clock select cable from M8572 module.	
15.2.28.2	Disconnect all the cables from the skidded MF28 to the system.	
15.2.29	Disconnect the DC power harnesses from the MF28 backplane.	
15.2.30	Install tinnerman nuts (item 2) in holes 2,4,11 and 13 as seen in drawing D-UA-MF28-8-8 sheet 2.	
15.2.31	Note: If the system has the cabinet locking feature, it must be removed and all the hardware must be saved for later reinstallation.	
15.2.32	Remove the mounting screws securing the MF28 power supply to the shipping skid, remove the power supply and set it to the side for the time being.	
15.2.33	Remove the power supply mounting bracket from the shipping skid and install it on the CPU rear equipment mounting door using screws (item 4) and washers (item 5) as seen in print D-UA-MF28-8-8 sheet # 3. (section A-A)	
15.2.34	Install the power supply in the bottom position on the CPU cabinet rear equipment mounting door as seen in drawing D-UA-MF28-8-8 sheet #2. (You may need 2 people for the step).	
15.2.35	Remove the mounting screws securing the MF28 battery box to the shipping skid and install it on the CPU rear equipment mounting door next to the power supply as seen in drawing D-UA-MF28-8-8 sheet 2.	
15.2.35	Move the cables out of the way to avoid damage and close the CPU door. Open the I/O door.	

DEC FORM NO EN-01022-16-N170-1(81)  
DRA 108

SIZE CODE NUMBER  
A SP MF20-0-2

SHEET 56 OF 52

## ENGINEERING SPECIFICATION

CONTINUATION SHEET

TITLE MF20 INSTALLATION PROCEDURE

- 15.2.36 Add tinerman nuts (item 2) to holes 5, 6, 36 and 37 if rear I/O door as seen in drawing D-UA-MF20-8-8 sheet 2.
- 15.2.37 Remove the mounting screws securing the MF20 card cage assembly to the horizontal mounting bars, remove the MF20 from the skid and set it aside.
- 15.2.38 Remove the mounting bars from the skid and install it in the system as seen in drawing D-UA-MF20-8-8 sheet 2.
- 15.2.39 Remove the intake bezel from the MF20 duct. Just loosen the 4 screws and it will slide off.
- 15.2.40 Install the MF20 on to the horizontal mounting bars with screws (item 4), lockwashers (item 5) and kep nuts (item 7), two screws and lockwashers for each corner except the lower left hand corner as seen in drawing E-UA-MF20-8-8 sheet 2. (You may need two people for this step.)
- Note: MF20-LU/LV will always be mounted nearest to the door pivot point.
- 15.2.41 Replace the intake bezel on the MF20 duct and tighten the 4 screws.
- 15.2.42 Secure the lower left hand corner of the MF20 with screw (item 4) and 2 lockwashers (item 5), also securing the ground strap (item 8). Installation should be such that the screw goes through one washer, the ground strap, the other washer, the horizontal mounting rail, and finally the keypad.
- 15.2.43 Secure the other end of the ground strap to the equipment mounting door rail at hole #14 with the same hardware used above. See E-UA-MF20-8-8 sheet 2.
- 15.2.44 If removed above, replace the rear door locking bracket on the I/O cabinet rear equipment mounting door.
- 15.2.45 Replace the external cabinet doors and grills.
- 15.2.46 Cut the foam on the back door around the air duct so that it will not restrict the airflow.
- 15.3 Cabling of the MF20 shall be done as follows:
- 15.3.1 All cables harnesses to be routed as shown in drawing E-UA-MF20-8-8 sheet 4.

DEC FORM NO EN-01022-14-N370-13(11)  
DRA 108

SIZE A  
SP MF20-0-2  
NUMBER REV B

SHEET 51 OF 62

## ENGINEERING SPECIFICATION

CONTINUATION SHEET

TITLE MF20 INSTALLATION PROCEDURE

- 15.3.2 Connect the d.c. power harness (7815671) to the MF20 backplane at terminal strips along the top and bottom as seen in chart # 1 on sheet 6 of drawing E-UA-MF20-8-8. Make sure the cable is routed properly before attaching.
- 15.3.3 Connect the +12vdc cable (7816287-81) to the master oscillator 8 pin male n lock per chart #48 of drawing E-UA-MF20-8-8.
- 15.3.4 Connect the master oscillator clock select cable (7815524) to the M8572 X-bus cable board (the short one) as seen in chart # 4 on sheet #4 of print E-UA-MF20-8-8.
- 15.3.5 Plug the x-bus cable board (M8572-88) into slot 2 of the CPU backplane. The other end plugs into the MF20 backplane, top to top, bottom to bottom etc as they come out of the CPU backplane.
- 15.3.6 Connect the margin sense cable (7815198) to the connector on the MF20 backplane as seen in chart # 9 on sheet # 6 of drawing E-UA-MF20-8-8.
- 15.3.7 Connect the MF20 AC power harness (7815222) from the MF20 power supply to the MF20 fans as seen in chart # 11 on sheet # 6 of drawing E-UA-MF20-8-8.
- 15.3.8 Plug the AC power cord from the MF20 power supply into one of the extension cords from the MA/MB 28 and then into J24 of the 863 power control.
- 15.3.9 Plug the door interlock harness (7815453) into the door switch of the MF20 and the other end into the existing fault harness where the MA/MB 28 was plugged in.
- 15.3.10 Plug the vane switch harness (7815447) on to the vane switches of the MF20 as seen in chart #7 on sheet 6 of drawing E-UA-MF20-8-8. The other end plugs into the existing fault harness where the MA/MB 28 was plugged into.
- 15.3.11 Plug the battery bus harness (78 15223) into the MF20 power supply, but do not turn it on at this time.

DEC FORM NO EN-01022-14-N370-13(11)  
DRA 108

SIZE A  
SP MF20-0-2  
NUMBER REV B

SHEET 52 OF 62

## ENGINEERING SPECIFICATION

CONTINUATION SHEET

TITLE MF20 INSTALLATION PROCEDURE

- 15.3.12 Remove the Dec remote turn on cable that runs from the external MF20 power supply to the front end panel (J4). Replace this with one remote turn on cable from the internal power supply to J4 of the front end panel and another one from the internal MF20 power supply (J3) to the external MF20 Power Supply (J2). Shown in chart # 21 and # 41 of drawing E-UA-MF20-8-8.
- 15.3.13 Make sure all these cables installed are securely fastened in place with supplied tie wraps. NEATLY!!
- 15.4 Proceed back to Sections 12 and 13 for electrical checkout and acceptance.

DEC FORM NO EN-01022-14-N370-13(11)  
DRA 108

SIZE A  
SP MF20-0-2  
NUMBER REV B

SHEET 53 OF 62

## ENGINEERING SPECIFICATION

CONTINUATION SHEET

TITLE MF20 INSTALLATION PROCEDURE

CPU CABINET REAR EQUIPMENT I/O DOOR

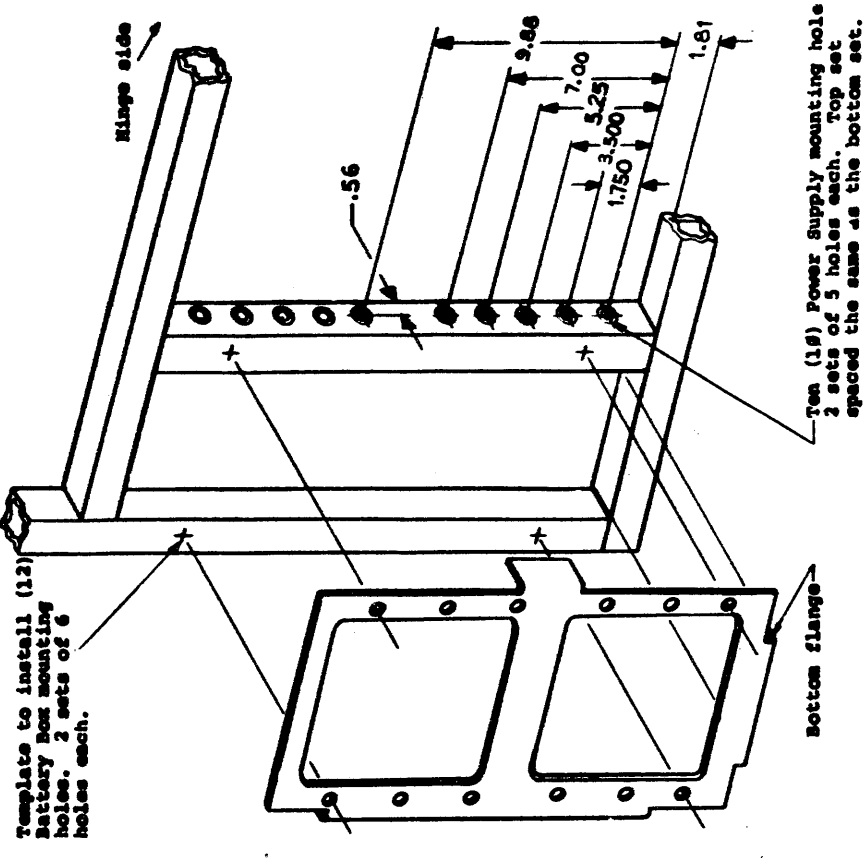

FIGURE #1

DEC FORM NO EN-01022-14-N370-13(11)  
DRA 108

SIZE A  
SP MF20-0-2  
NUMBER REV B

SHEET 54 OF 62

**ENGINEERING SPECIFICATION**

CONTINUATION SHEET

TITLE MF20 INSTALLATION PROCEDURE

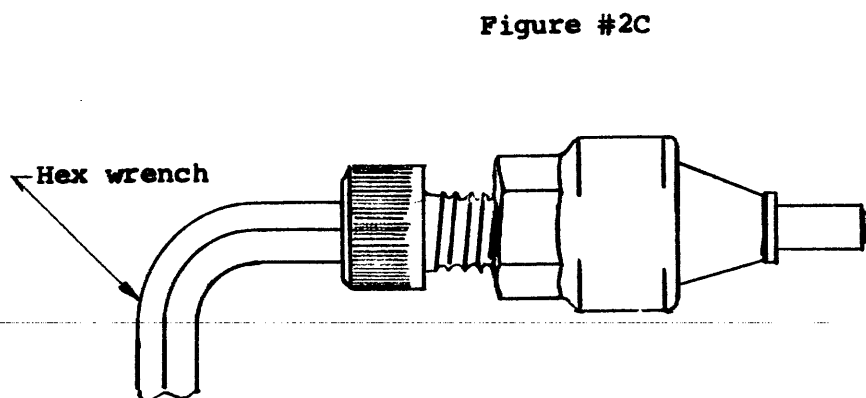
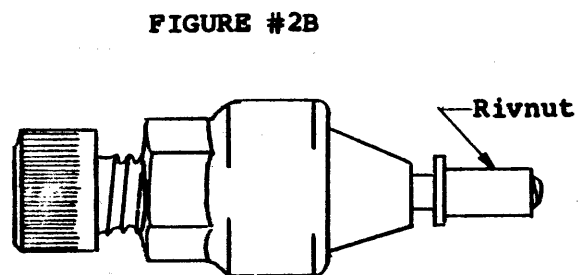
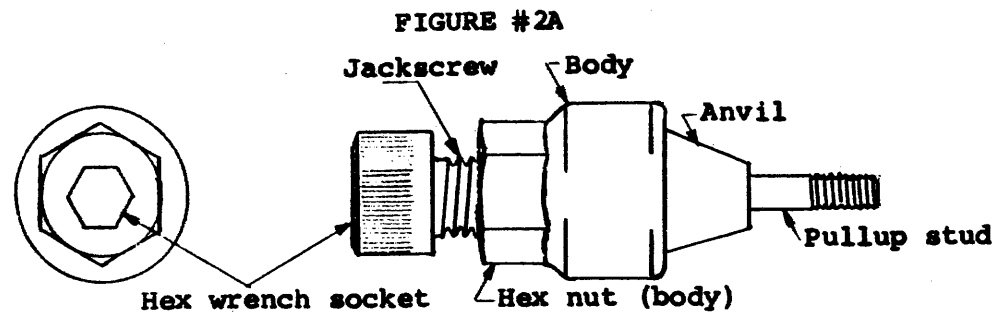

SIZE	CODE	NUMBER	REV
A	SP	MF20-0-2	B

**ENGINEERING SPECIFICATION**

CONTINUATION SHEET

TITLE MF20 INSTALLATION PROCEDURE

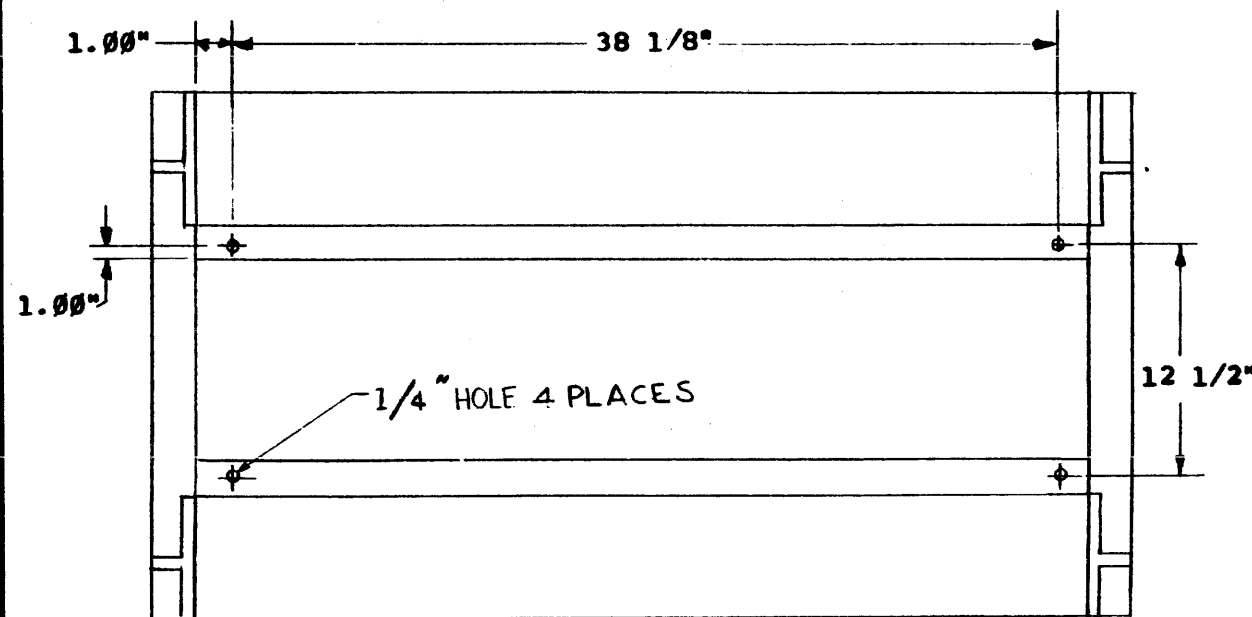

REAR OF CABINET

FIGURE # 3  
(TOP VIEW OF CPU CAB)

SIZE	CODE	NUMBER	REV
A	SP	MF20-0-2	B

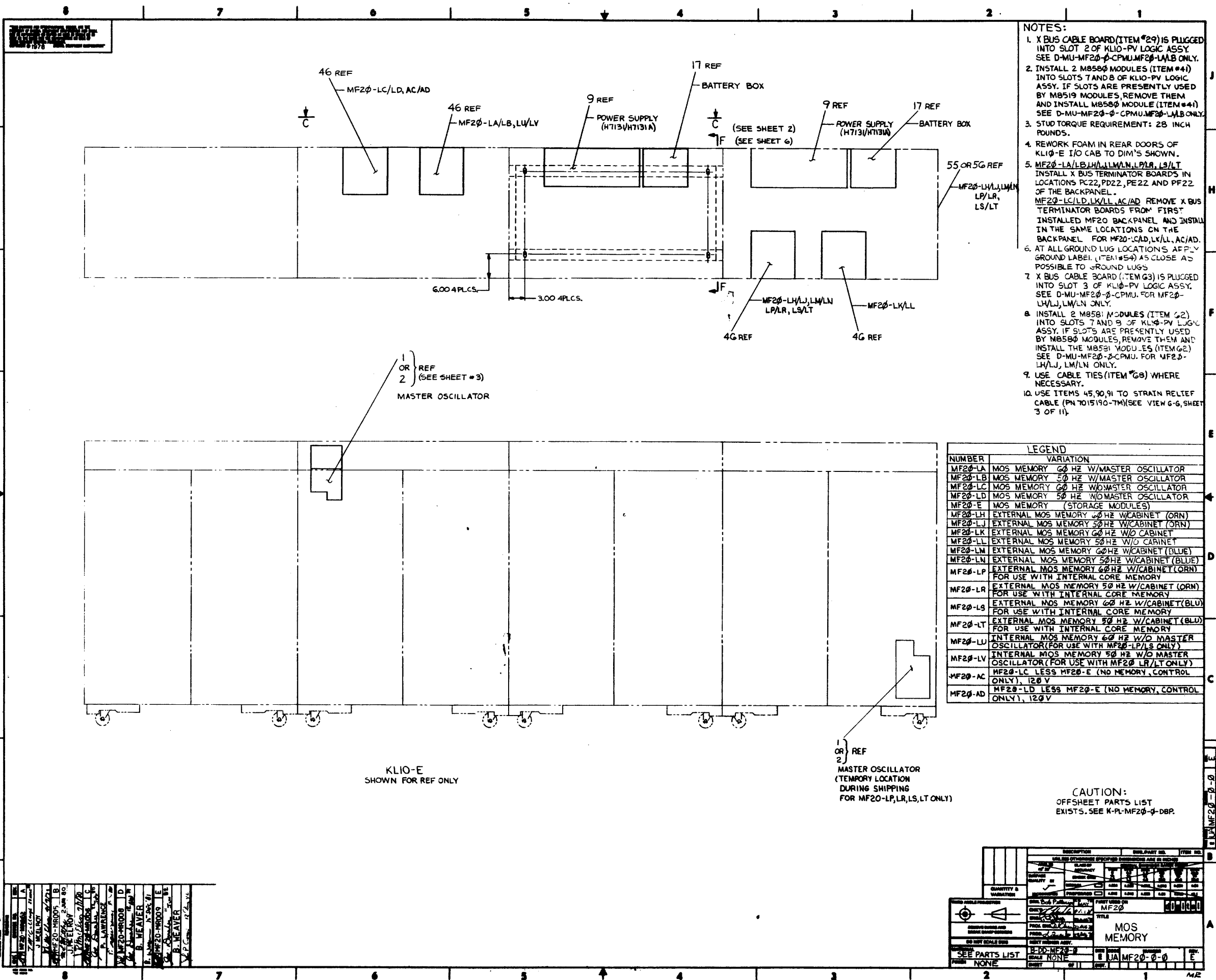

- NOTES:**
- X BUS CABLE BOARD (ITEM #29) IS PLUGGED INTO SLOT 2 OF KLI0-PV LOGIC ASSY. SEE D-MU-MF20-0-CPMU.MF20-LA/LB ONLY.
  - INSTALL 2 M8580 MODULES (ITEM #4) INTO SLOTS 7 AND 8 OF KLI0-PV LOGIC ASSY. IF SLOTS ARE PRESENTLY USED BY M8519 MODULES, REMOVE THEM AND INSTALL M8580 MODULE (ITEM #4). SEE D-MU-MF20-0-CPMU.MF20-LA/LB ONLY.
  - STUD TORQUE REQUIREMENT: 28 INCH POUNDS.
  - REWORK FOAM IN REAR DOORS OF KLI0-E I/O CAB TO DIM'S SHOWN.
  - MF20-LA/LB, LH/LM, LN, LP/LR, LS/LT INSTALL X BUS TERMINATOR BOARDS IN LOCATIONS PC22, PD22, PE22 AND PF22 OF THE BACKPANEL. MF20-LC/LD, LK/LL, AC/AD REMOVE X BUS TERMINATOR BOARDS FROM FIRST INSTALLED MF20 BACKPANEL AND INSTALL IN THE SAME LOCATIONS ON THE BACKPANEL FOR MF20-LC/LD, LK/LL, AC/AD.
  - AT ALL GROUND LUG LOCATIONS APPLY GROUND LABEL (ITEM #54) AS CLOSE AS POSSIBLE TO GROUND LUGS.
  - X BUS CABLE BOARD (ITEM #29) IS PLUGGED INTO SLOT 3 OF KLI0-PV LOGIC ASSY. SEE D-MU-MF20-0-CPMU. FOR MF20-LH/LJ, LM/LN ONLY.
  - INSTALL 2 M8581 MODULES (ITEM #2) INTO SLOTS 7 AND 8 OF KLI0-PV LOGIC ASSY. IF SLOTS ARE PRESENTLY USED BY M8580 MODULES, REMOVE THEM AND INSTALL THE M8581 MODULES (ITEM #2). SEE D-MU-MF20-0-CPMU. FOR MF20-LH/LJ, LM/LN ONLY.
  - USE CABLE TIES (ITEM #68) WHERE NECESSARY.
  - USE ITEMS 45, 90, 91 TO STRAIN RELIEF CABLE (PN 1015190-7M) (SEE VIEW G-G, SHEET 3 OF 11).

**LEGEND**

NUMBER	VARIATION
MF20-LA	MOS MEMORY 60 HZ W/MASTER OSCILLATOR
MF20-LB	MOS MEMORY 50 HZ W/MASTER OSCILLATOR
MF20-LC	MOS MEMORY 60 HZ W/MASTER OSCILLATOR
MF20-LD	MOS MEMORY 50 HZ W/MASTER OSCILLATOR
MF20-E	MOS MEMORY (STORAGE MODULES)
MF20-LH	EXTERNAL MOS MEMORY 60 HZ W/CABINET (ORN)
MF20-LJ	EXTERNAL MOS MEMORY 50 HZ W/CABINET (ORN)
MF20-LK	EXTERNAL MOS MEMORY 60 HZ W/O CABINET
MF20-LL	EXTERNAL MOS MEMORY 50 HZ W/O CABINET
MF20-LM	EXTERNAL MOS MEMORY 60 HZ W/CABINET (BLUE)
MF20-LN	EXTERNAL MOS MEMORY 50 HZ W/CABINET (BLUE)
MF20-LP	EXTERNAL MOS MEMORY 60 HZ W/CABINET (ORN) FOR USE WITH INTERNAL CORE MEMORY
MF20-LR	EXTERNAL MOS MEMORY 50 HZ W/CABINET (ORN) FOR USE WITH INTERNAL CORE MEMORY
MF20-LS	EXTERNAL MOS MEMORY 60 HZ W/CABINET (BLU) FOR USE WITH INTERNAL CORE MEMORY
MF20-LT	EXTERNAL MOS MEMORY 50 HZ W/CABINET (BLU) FOR USE WITH INTERNAL CORE MEMORY
MF20-LU	INTERNAL MOS MEMORY 60 HZ W/O MASTER OSCILLATOR (FOR USE WITH MF20-LP/LS ONLY)
MF20-LV	INTERNAL MOS MEMORY 50 HZ W/O MASTER OSCILLATOR (FOR USE WITH MF20-LR/LT ONLY)
MF20-AC	MF20-LC LESS MF20-E (NO MEMORY, CONTROL ONLY), 120 V
MF20-AD	MF20-LD LESS MF20-E (NO MEMORY, CONTROL ONLY), 120 V

**CAUTION:**  
OFFSHEET PARTS LIST EXISTS. SEE K-PL-MF20-0-DBP.

1	MF20-LA	46 REF
2	MF20-LB	46 REF
3	MF20-LC	46 REF
4	MF20-LD	46 REF
5	POWER SUPPLY (H713/H713A)	9 REF
6	BATTERY BOX	17 REF
7	MF20-LH/LJ, LM/LN, LP/LR, LS/LT	55 OR 56 REF
8	MF20-LK/LL	46 REF
9	MASTER OSCILLATOR	1 OR 2 REF (SEE SHEET #3)

**QUANTITY & VARIATION**

DESCRIPTION	QUANTITY	VARIATION
MOS MEMORY	46	MF20-LA
MOS MEMORY	46	MF20-LB
MOS MEMORY	46	MF20-LC
MOS MEMORY	46	MF20-LD
POWER SUPPLY	9	H713/H713A
BATTERY BOX	17	
EXTERNAL MOS MEMORY	55 OR 56	LH/LJ, LM/LN, LP/LR, LS/LT
EXTERNAL MOS MEMORY	46	LK/LL
MASTER OSCILLATOR	1 OR 2	

SEE PARTS LIST FOR NONE

KLI0-E  
SHOWN FOR REF ONLY

1 OR 2 REF  
MASTER OSCILLATOR  
(TEMPORARY LOCATION DURING SHIPPING FOR MF20-LP, LR, LS, LT ONLY)

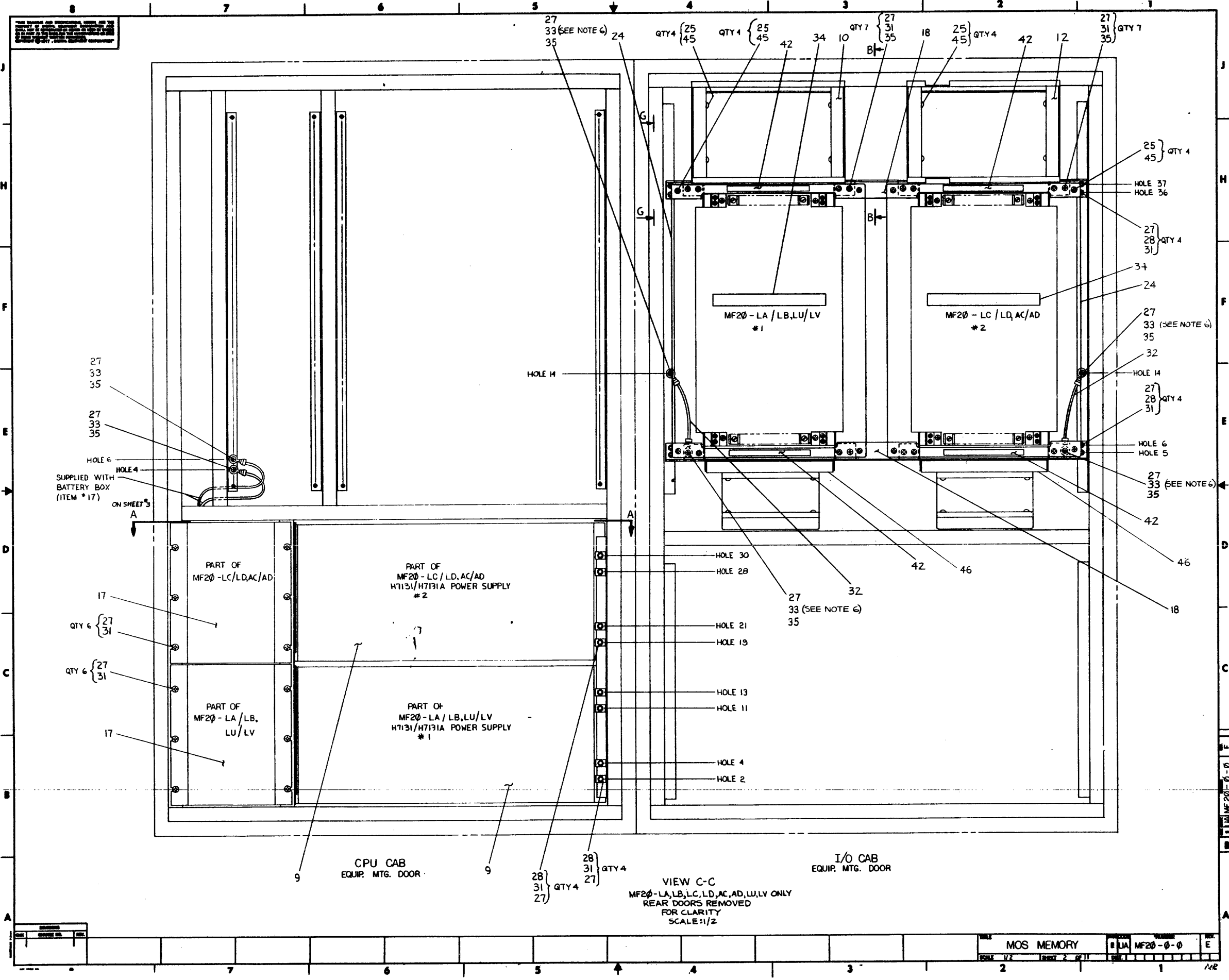

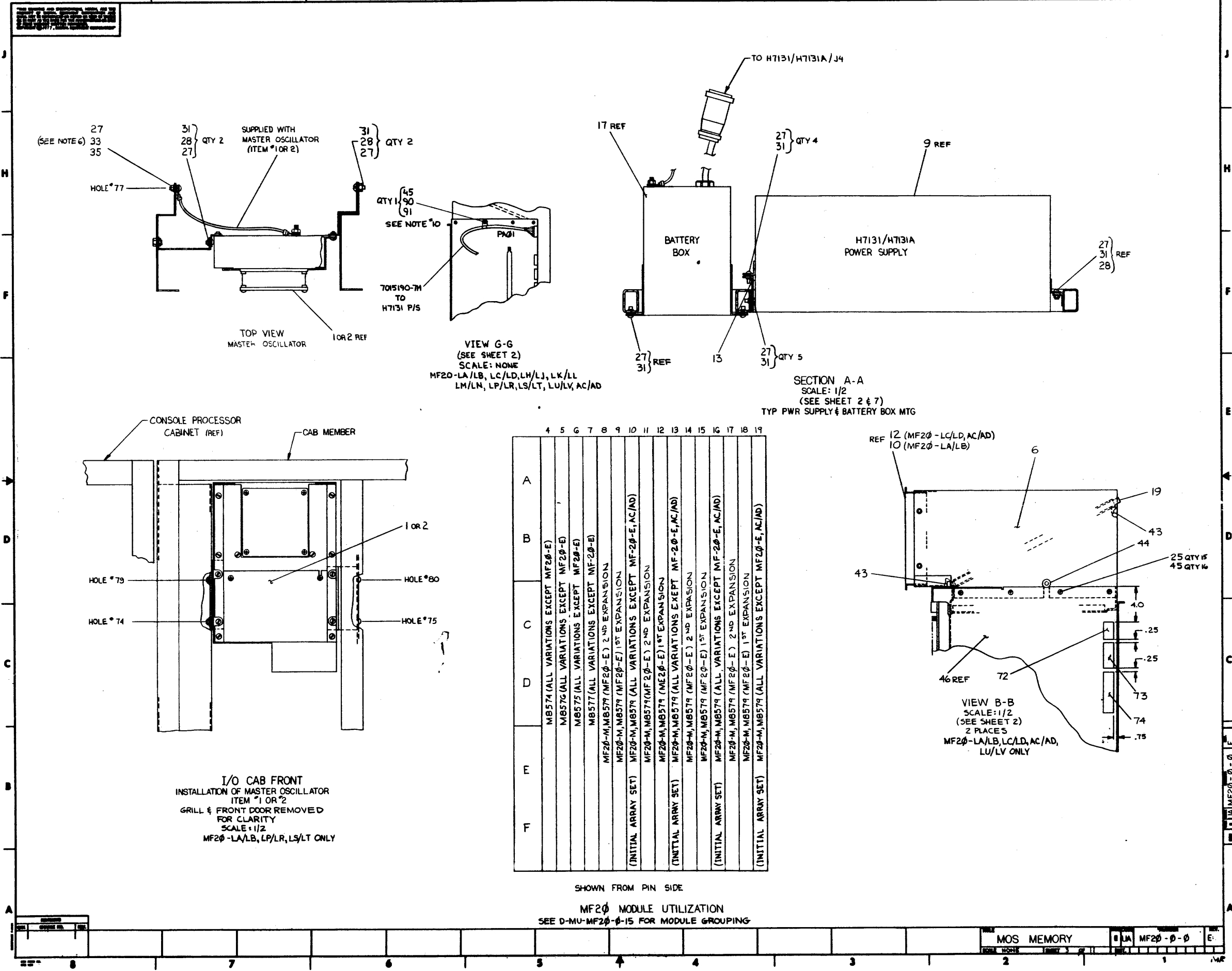

THIS DRAWING AND SPECIFICATIONS HEREIN ARE THE PROPERTY OF DIGITAL EQUIPMENT CORPORATION AND SHALL NOT BE REPRODUCED OR COPIED OR USED IN WHOLE OR IN PART AS THE BASIS FOR THE MANUFACTURE OR SALE OF ITEMS WITHOUT WRITTEN PERMISSION. COPYRIGHT © 1977 DIGITAL EQUIPMENT CORPORATION.

DUA MF20-0-0

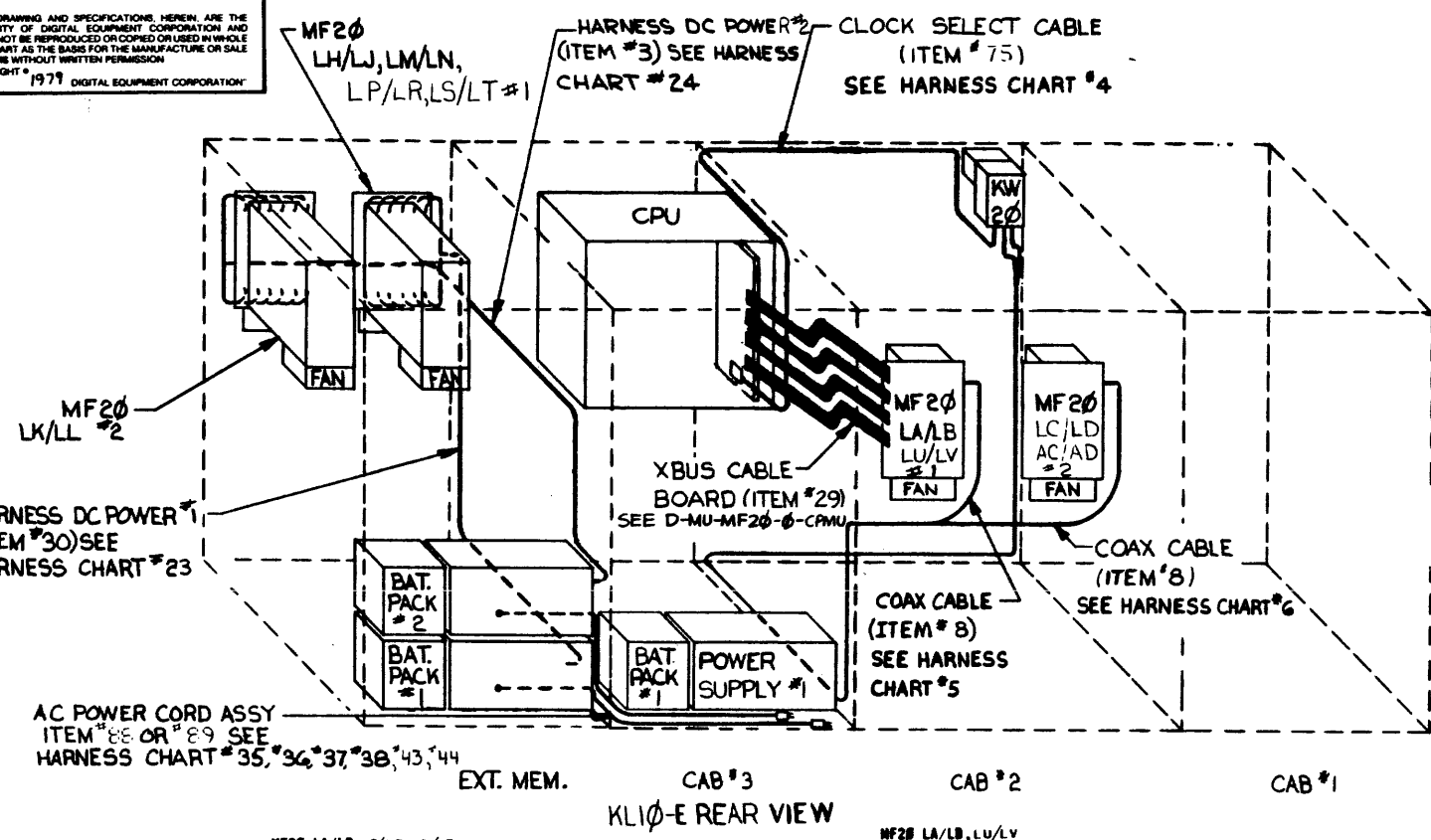

MF20 LA/LB, LP/LR, LS/LT

HARNESS CONNECTION CHART #4				
ITEM NO.	HARNESS TERM	POINT	CONNECTION	WITH
75		J1	CPU #1 M8572	
75		J2	KW20/J10	

MF20 LA/LB, LU/LV

HARNESS CONNECTION CHART #5				
ITEM NO.	HARNESS TERM	POINT	CONNECTION	WITH
8			CPU #1 (COAX COMM)	KW20/10
8			MF20 #1 (BACKPLANE)	KW20/11

MF20 LC/LD, AC/AD

HARNESS CONNECTION CHART #8				
ITEM NO.	HARNESS TERM	POINT	CONNECTION	WITH
8			MF20 #2 (BACKPLANE)	KW20/13

MF20 LJ, LN

HARNESS CONNECTION CHART #35				
ITEM NO.	HARNESS TERM	POINT	CONNECTION	WITH
70		P1	003/J32	
70		1	H7131 #1/TB 1-GND	
70		3	H7131 #1/TB 1-NEUT	
70		2	H7131 #1/TB 1-LINE	

MF20 LL

HARNESS CONNECTION CHART #36				
ITEM NO.	HARNESS TERM	POINT	CONNECTION	WITH
88		P1	003/J25	
88		1	H7131 #2/TB 1-GND	
88		3	H7131 #2/TB 1-NEUT	
88		2	H7131 #2/TB 1-LINE	

MF20 LN, LM

HARNESS CONNECTION CHART #37				
ITEM NO.	HARNESS TERM	POINT	CONNECTION	WITH
71		P1	003/J32	
71		1	H7131 #1/TB 1-GND	
71		3	H7131 #1/TB 1-NEUT	
71		2	H7131 #1/TB 1-LINE	

MF20 LK

HARNESS CONNECTION CHART #38				
ITEM NO.	HARNESS TERM	POINT	CONNECTION	WITH
89		P1	003/J25	
89		1	H7131 #2/TB 1-GND	
89		3	H7131 #2/TB 1-NEUT	
89		2	H7131 #2/TB 1-LINE	

MF20 LH/LJ, LM/LN, LP/LR, LS/LT

HARNESS CONNECTION CHART #23				
ITEM NO.	HARNESS TERM	POINT	CONNECTION	WITH
30		1	H7131 #1/-5.2V(-)L	
		2	H7131 #1/-5.2V(+)L	
		3	H7131 #1/-5.2V(-)L	
		4	H7131 #1/-5.2V(+)L	
		5	H7131 #1/-5.2V(-)U	
		6	H7131 #1/-5.2V(+)U	
		7	H7131 #1/-5.2V(-)U	
		8	H7131 #1/-5.2V(+)U	
		9	MF20 #1/GNDA U	
		10	MF20 #1/+12B U	
		11	MF20 #1/GNDB U	
		12	MF20 #1/+5B U	
		13	MF20 #1/GNDC U	
		14	MF20 #1/ 12A U	
		15	MF20 #1/GNDD U	
		16	MF20 #1/ 5A U	
		17	MF20 #1/GNDE U	
		18	MF20 #1/-5.2B U	
		19	MF20 #1/GNDF U	
		20	MF20 #1/-5.2A U	
		21	MF20 #1/GNDH U	
		22	MF20 #1/-2 U	
		23	MF20 #1/-2 L	
		24	MF20 #1/GNDH L	
		25	MF20 #1/-5.2A L	
		26	MF20 #1/GNDF L	
		27	MF20 #1/-5.2B L	
		28	MF20 #1/GNDE L	
		29	MF20 #1/+5A L	
		30	MF20 #1/GNDD L	
		31	MF20 #1/+12A L	
		32	MF20 #1/GNDC L	
		33	MF20 #1/+5B L	
		34	MF20 #1/GNDB L	
		35	MF20 #1/+12B L	
		36	MF20 #1/GNDA L	
		37	H7131 #1/-2.0V(-)L	
		38	H7131 #1/-2.0V(+)L	
		39	H7131 #1/-2.0V(-)U	
		40	H7131 #1/-2.0V(+)U	
		41	H7131 #1/+5.0V(+)L	
		42	H7131 #1/+5.0V(-)L	
		43	H7131 #1/+5.0V(+)L	
		44	H7131 #1/+5.0V(-)L	
		45	H7131 #1/+5.0V(+)U	
		46	H7131 #1/+5.0V(-)U	
		47	H7131 #1/+5.0V(+)U	
		48	H7131 #1/+5.0V(-)U	
		49	H7131 #1/+12.0V(+)L	
		50	H7131 #1/+12.0V(-)L	
		51	H7131 #1/+12.0V(+)L	
		52	H7131 #1/+12.0V(-)L	
		53	H7131 #1/+12.0V(+)U	
		54	H7131 #1/+12.0V(-)U	
		55	H7131 #1/+12.0V(+)U	
		56	H7131 #1/+12.0V(-)U	

MF20 LK/LL

HARNESS CONNECTION CHART #24				
ITEM NO.	HARNESS TERM	POINT	CONNECTION	WITH
3		1	H7131 #2/-5.2V(-)L	
		2	H7131 #2/-5.2V(+)L	
		3	H7131 #2/-5.2V(-)L	
		4	H7131 #2/-5.2V(+)L	
		5	H7131 #2/-5.2V(-)U	
		6	H7131 #2/-5.2V(+)U	
		7	H7131 #2/-5.2V(-)U	
		8	H7131 #2/-5.2V(+)U	
		9	MF20 #2/-2 L	
		10	MF20 #2/GNDH L	
		11	MF20 #2/-5.2A L	
		12	MF20 #2/GNDF L	
		13	MF20 #2/-5.2B L	
		14	MF20 #2/GNDE L	
		15	MF20 #2/+5A L	
		16	MF20 #2/GNDD L	
		17	MF20 #2/+12A L	
		18	MF20 #2/GNDC L	
		19	MF20 #2/+5B L	
		20	MF20 #2/GNDB L	
		21	MF20 #2/+12B L	
		22	MF20 #2/GNDA L	
		23	MF20 #2/GNDA U	
		24	MF20 #2/+12B U	
		25	MF20 #2/GNDB U	
		26	MF20 #2/+5B U	
		27	MF20 #2/GNDC U	
		28	MF20 #2/+12A U	
		29	MF20 #2/GNDD U	
		30	MF20 #2/+5A U	
		31	MF20 #2/GNDE J	
		32	MF20 #2/-5.2B U	
		33	MF20 #2/GNDF U	
		34	MF20 #2/-5.2A U	
		35	MF20 #2/GNDH U	
		36	MF20 #2/-2 U	
		37	H7131 #2/-2.0V(-)L	
		38	H7131 #2/-2.0V(+)L	
		39	H7131 #2/-2.0V(-)U	
		40	H7131 #2/-2.0V(+)U	
		41	H7131 #2/+5.0V(+)L	
		42	H7131 #2/+5.0V(-)L	
		43	H7131 #2/+5.0V(+)L	
		44	H7131 #2/+5.0V(-)L	
		45	H7131 #2/+5.0V(+)U	
		46	H7131 #2/+5.0V(-)U	
		47	H7131 #2/+5.0V(+)U	
		48	H7131 #2/+5.0V(-)U	
		49	H7131 #2/+12.0V(+)L	
		50	H7131 #2/+12.0V(-)L	
		51	H7131 #2/+12.0V(+)L	
		52	H7131 #2/+12.0V(-)L	
		53	H7131 #2/+12.0V(+)U	
		54	H7131 #2/+12.0V(-)U	
		55	H7131 #2/+12.0V(+)U	
		56	H7131 #2/+12.0V(-)U	

REVISION HISTORY

DATE	ECO NUMBER	REV.

TITLE  
MOS MEMORY

DOCUMENT NUMBER

SIZE CODE	NUMBER	REV
DUA	MF20-0-0	E

SCALE NONE SHEET 4 OF 11

THIS DRAWING AND SPECIFICATIONS HEREIN ARE THE PROPERTY OF DIGITAL EQUIPMENT CORPORATION AND SHALL NOT BE REPRODUCED OR COPIED OR USED IN WHOLE OR IN PART AS THE BASIS FOR THE MANUFACTURE OR SALE OF ITEMS WITHOUT WRITTEN PERMISSION.  
 COPYRIGHT © 1979 DIGITAL EQUIPMENT CORPORATION

JUMPER CABLE 1FT (ITEM #23)

X BUS CABLE BOARD (ITEM #63) SEE D-MU-MF20-0-CPMU

CPU

FAN

FAN

FAN

FAN

FAN

FAN

FAN

FAN

FAN

FAN

FAN

FAN

FAN

FAN

FAN

FAN

FAN

FAN

FAN

FAN

FAN

FAN

FAN

FAN

FAN

FAN

FAN

FAN

FAN

FAN

FAN

FAN

FAN

COAX CABLE (ITEM #8) SEE HARNESS CHART #5

MASTER OSCILLATOR AC POWER HARNESS (ITEM #14 OR #84) SEE HARNESS CHART #3 OR #49

AC POWER HARNESS MF20 (ITEM #5) SEE HARNESS CHART #11

ITEM #14 CONNECTS TO POWER SUPPLY #1 OF CAB #3 ONLY. ITEM #84 CONNECTS TO POWER SUPPLY #1 OF EXT. MEM. CAB ONLY.

BAT. PACK #1

POWER SUPPLY #1

BAT. PACK #2

POWER SUPPLY #2

BAT. PACK #1

POWER SUPPLY #1

BAT. PACK #1

POWER SUPPLY #1

BAT. PACK #1

POWER SUPPLY #1

BAT. PACK #1

POWER SUPPLY #1

BAT. PACK #1

POWER SUPPLY #1

BAT. PACK #1

POWER SUPPLY #1

BAT. PACK #1

POWER SUPPLY #1

BAT. PACK #1

POWER SUPPLY #1

BAT. PACK #1

POWER SUPPLY #1

BAT. PACK #1

POWER SUPPLY #1

BAT. PACK #1

POWER SUPPLY #1

BAT. PACK #1

POWER SUPPLY #1

BAT. PACK #1

POWER SUPPLY #1

EXT. MEM.

CAB #3

CAB #2

CAB #1

AC POWER CORD ASSY ITEM #88 OR #89, SEE HARNESS CHART #15 AND #17

KL10-E REAR VIEW

MF20 LU/LV  
HARNESS CONNECTION CHART #50

ITEM NO.	HARNESS TERM		CONNECTION	WITH
	POINT	CONNECTION		
61		P 2	H7131 #1/J2	
61		P 1	H7131 #2/J2 (EXT)	

MF20 LA/LB  
HARNESS CONNECTION CHART #3

ITEM NO.	HARNESS TERM		CONNECTION	WITH
	POINT	CONNECTION		
14		J1	KW20/F1-1	
14		J2	KW20/F1-2	
14			H7131 #1/TBS1-NEUT	
14			H7131 #1/TBS1-LINE	

MF20 LA/LB, LU/LV  
HARNESS CONNECTION CHART #11

ITEM NO.	HARNESS TERM		CONNECTION	WITH
	POINT	CONNECTION		
5		J1	MF20 #1 FAN 2-1	
		J2	MF20 #1 FAN 2-2	
		J3	MF20 #1 FAN 1-1	
		J4	MF20 #1 FAN 1-2	
	5		H7131 #1/TB2 -1	
	6		H7131 #1/TB2 -2	
	7		H7131 #1/TB2 -3	
	8		H7131 #1/TB2 -4	

MF20 LB, LV  
HARNESS CONNECTION CHART #15

ITEM NO.	HARNESS TERM		CONNECTION	WITH
	POINT	CONNECTION		
88		P1	883/J26	
88	1		H7131 #2/TB 1-GND	
88	3		H7131 #1/TB 1-NEUT	
88	2		H7131 #1/TB 1-LINE	

MF20 LA/LB, LU/LV  
HARNESS CONNECTION CHART #5

ITEM NO.	HARNESS TERM		CONNECTION	WITH
	POINT	CONNECTION		
8		CPU #1 (COAX CABLE)	KW20/J8	
8		MF20 #1 (BACKPLANE)	KW20/J1	

MF20 LP/LR, LS/LT  
HARNESS CONNECTION CHART #49

ITEM NO.	HARNESS TERM		CONNECTION	WITH
	POINT	CONNECTION		
84		J 1	KW20/F1-1	
84		J 2	KW20/F1-2	
84	3		H7131 #1/TBS1-NEUT	
84	4		H7131 #1/TBS1-LINE	

MF20 LA, LU  
HARNESS CONNECTION CHART #17

ITEM NO.	HARNESS TERM		CONNECTION	WITH
	POINT	CONNECTION		
89		P1	883/J26	
89	1		H7131 #1/TB 1-GND	
89	3		H7131 #1/TB 1-NEUT	
89	2		H7131 #1/TB 1-LINE	

REVISION HISTORY

DATE	ECO NUMBER	REV.

TITLE  
MOS MEMORY

DOCUMENT NUMBER

SIZE CODE	NUMBER	REV.
DUA	MF20-0-0	E

SCALE NONE SHEET 5 OF 11

THIS DRAWING AND SPECIFICATIONS HEREIN ARE THE PROPERTY OF DIGITAL EQUIPMENT CORPORATION AND SHALL NOT BE REPRODUCED OR COPIED OR USED IN WHOLE OR IN PART AS THE BASIS FOR THE MANUFACTURE OR SALE OF ITEMS WITHOUT WRITTEN PERMISSION. COPYRIGHT © 1979 DIGITAL EQUIPMENT CORPORATION.

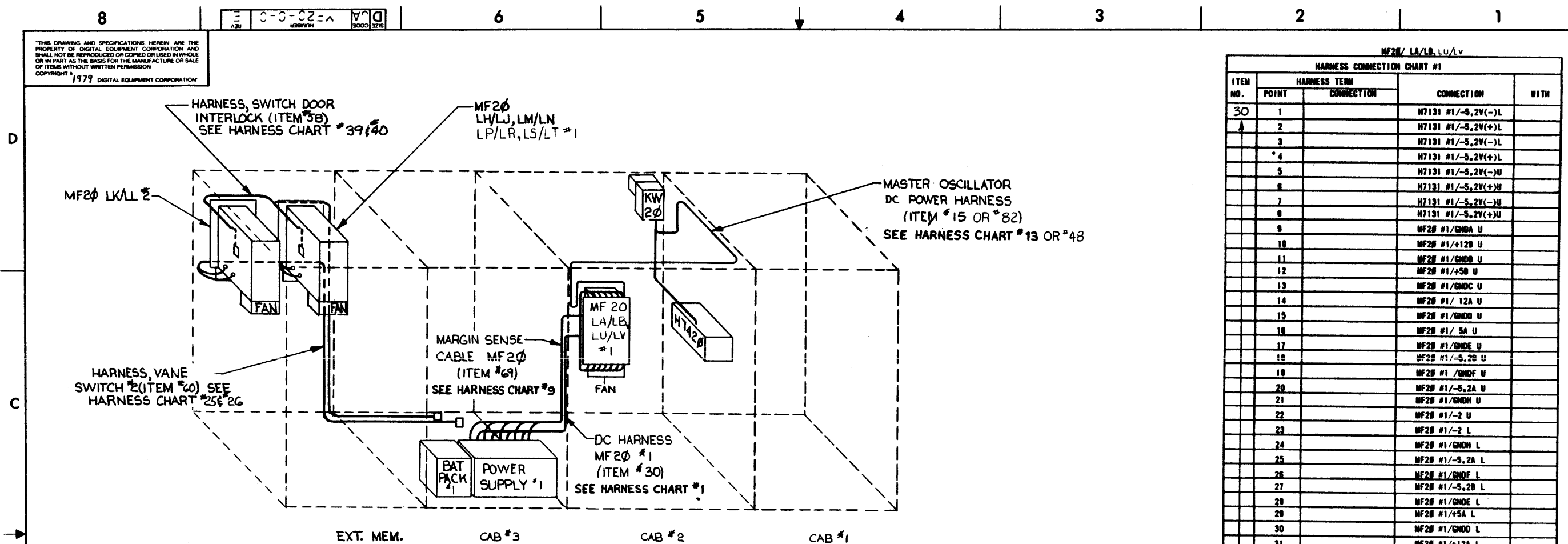

KLIØ-E REAR VIEW

MF2Ø LA/LB, LU/LV				
HARNESS CONNECTION CHART #1				
ITEM NO.	HARNESS TERM POINT	CONNECTION	CONNECTION	WITH
30	1		H7131 #1/-5.2V(-)L	
	2		H7131 #1/-5.2V(+)L	
	3		H7131 #1/-5.2V(-)L	
	4		H7131 #1/-5.2V(+)L	
	5		H7131 #1/-5.2V(-)U	
	6		H7131 #1/-5.2V(+)U	
	7		H7131 #1/-5.2V(-)U	
	8		H7131 #1/-5.2V(+)U	
	9		MF2Ø #1/GNDA U	
	10		MF2Ø #1/+12Ø U	
	11		MF2Ø #1/GNDB U	
	12		MF2Ø #1/+5Ø U	
	13		MF2Ø #1/GNDC U	
	14		MF2Ø #1/ 12A U	
	15		MF2Ø #1/GNDD U	
	16		MF2Ø #1/ 5A U	
	17		MF2Ø #1/GNDE U	
	18		MF2Ø #1/-5.2Ø U	
	19		MF2Ø #1/GNDF U	
	20		MF2Ø #1/-5.2A U	
	21		MF2Ø #1/GNDH U	
	22		MF2Ø #1/-2 U	
	23		MF2Ø #1/-2 L	
	24		MF2Ø #1/GNDH L	
	25		MF2Ø #1/-5.2A L	
	26		MF2Ø #1/GNDF L	
	27		MF2Ø #1/-5.2Ø L	
	28		MF2Ø #1/GNDE L	
	29		MF2Ø #1/+5A L	
	30		MF2Ø #1/GNDD L	
	31		MF2Ø #1/+12A L	
	32		MF2Ø #1/GNDC L	
	33		MF2Ø #1/+5Ø L	
	34		MF2Ø #1/GNDB L	
	35		MF2Ø #1/+12Ø L	
	36		MF2Ø #1/GNDA L	
	37		H7131 #1/-2.0V(-)L	
	38		H7131 #1/-2.0V(+)L	
	39		H7131 #1/-2.0V(-)U	
	40		H7131 #1/-2.0V(+)U	
	41		H7131 #1/+5.0V(+)L	
	42		H7131 #1/+5.0V(-)L	
	43		H7131 #1/+5.0V(+)L	
	44		H7131 #1/+5.0V(-)L	
	45		H7131 #1/+5.0V(+)U	
	46		H7131 #1/+5.0V(-)U	
	47		H7131 #1/+5.0V(+)U	
	48		H7131 #1/+5.0V(-)U	
	49		H7131 #1/+12.0V(+)L	
	50		H7131 #1/+12.0V(-)L	
	51		H7131 #1/+12.0V(+)L	
	52		H7131 #1/+12.0V(-)L	
	53		H7131 #1/+12.0V(+)U	
	54		H7131 #1/+12.0V(-)U	
	55		H7131 #1/+12.0V(+)U	
	56		H7131 #1/+12.0V(-)U	

MF2Ø LA/LB, LU/LV				
HARNESS CONNECTION CHART #9				
ITEM NO.	HARNESS TERM POINT	CONNECTION	CONNECTION	WITH
69		J1	MF2Ø #1/PAB1	
	6		H7131 #1/TB6-2	
	7		H7131 #1/TB6-3	
	8		H7131 #1/TB5-3	
	5		H7131 #1/TB5-2	
	4		H7131 #1/TB4-3	
	3		H7131 #1/TB4-2	
	2		H7131 #1/TB3-2	
	1		H7131 #1/TB3-3	
69		P1	H7131 #1/J1	

MF2Ø LH/LJ, LM/LN, LP/LR, LS/LT				
HARNESS CONNECTION CHART #25				
ITEM NO.	HARNESS TERM POINT	CONNECTION	CONNECTION	WITH
60	1,2		MF2Ø #1/SW2(-)	
	3,4		MF2Ø #1/SW2(L)	
	5,6		MF2Ø #1/SW2(+)	
		J5	FAULT HARNESS/P3	
	25		MF2Ø #1/SW1(-)	
	26		MF2Ø #1/SW1(-)	
	27		MF2Ø #1/SW1(L)	
	28		MF2Ø #1/SW1(L)	
	29		MF2Ø #1/SW1(+)	
	30		MF2Ø #1/SW1(+)	
60		P1	WB2Ø VANE	

MF2Ø LK LL				
HARNESS CONNECTION CHART #26				
ITEM NO.	HARNESS TERM POINT	CONNECTION	CONNECTION	WITH
60	16		MF2Ø #2/SW2(-)	
	17		MF2Ø #2/SW2(L)	
	18		MF2Ø #2/SW2(+)	
	19		MF2Ø #2/SW1(-)	
	20		MF2Ø #2/SW1(-)	
	21		MF2Ø #2/SW1(L)	
	22		MF2Ø #2/SW1(L)	
	23		MF2Ø #2/SW1(+)	
60	24		MF2Ø #2/SW1(+)	

MF2Ø LA/LB				
HARNESS CONNECTION CHART #13				
ITEM NO.	HARNESS TERM POINT	CONNECTION	CONNECTION	WITH
15		P1	KW2Ø/JØ	
15	7		H742Ø #3/J13-8	
15	8		H742Ø #3/J13-5	
15	9		MF2Ø #1/GNDA U	
15	10		MF2Ø #1/ 12Ø U	

MF2Ø LH/LJ, LM/LN, LP/LR, LS/LT				
HARNESS CONNECTION CHART #39				
ITEM NO.	HARNESS TERM POINT	CONNECTION	CONNECTION	WITH
5Ø		J1	MF2Ø #1/DOOR SWITCH	
5Ø	5,6		FAULT HARNESS/J1-1	
5Ø	7,8		FAULT HARNESS/J1-3	
5Ø		J3	WB2Ø DOOR SW	

MF2Ø LK LL				
HARNESS CONNECTION CHART #40				
ITEM NO.	HARNESS TERM POINT	CONNECTION	CONNECTION	WITH
5Ø		J2	MF2Ø #2/DOOR SWITCH	

REVISION HISTORY		
DATE	ECO NUMBER	REV.

TITLE  
MOS MEMORY

DOCUMENT NUMBER		
SIZE CODE	NUMBER	REV.
DJA	MF2Ø-Ø-Ø	E
SCALE NONE	SHEET 6	OF 11

THIS DRAWING AND SPECIFICATIONS HEREIN ARE THE PROPERTY OF DIGITAL EQUIPMENT CORPORATION AND SHALL NOT BE REPRODUCED OR COPIED OR USED IN WHOLE OR IN PART AS THE BASIS FOR THE MANUFACTURE OR SALE OF ITEMS WITHOUT WRITTEN PERMISSION. COPYRIGHT © 1979 DIGITAL EQUIPMENT CORPORATION

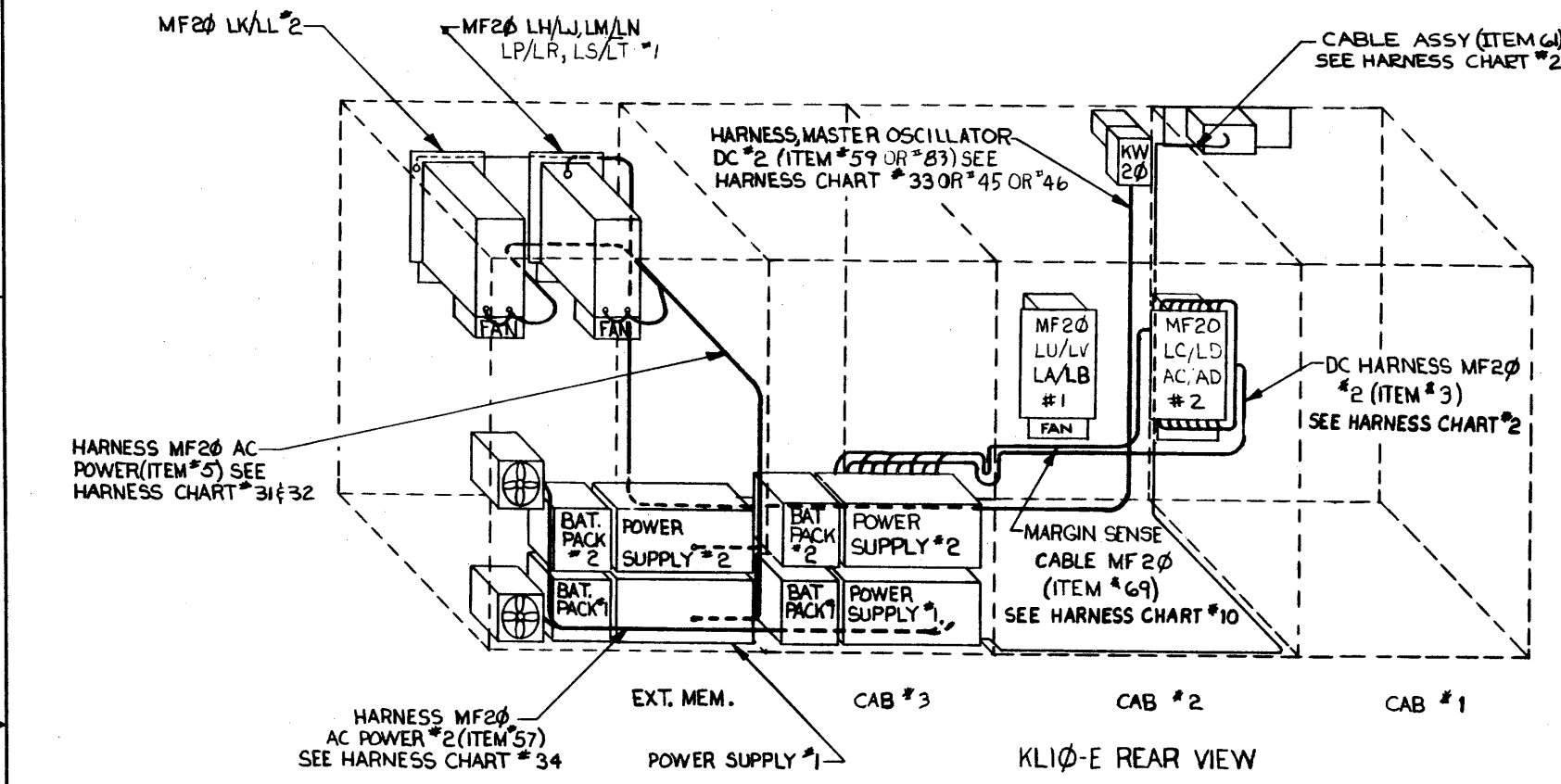

MF2Ø LC/LD, AC/AD

HARNESS CONNECTION CHART #2

ITEM NO.	HARNESS TERM		CONNECTION	WITH
	POINT	CONNECTION		
3	1		H7131 #2/-5.2V(-)L	
2			H7131 #2/-5.2V(+L)	
3			H7131 #2/-5.2V(-)L	
4			H7131 #2/-5.2V(+L)	
5			H7131 #2/-5.2V(-)U	
6			H7131 #2/-5.2V(+U)	
7			H7131 #2/-5.2V(-)U	
8			H7131 #2/-5.2V(+U)	
9			MF2Ø #2/-2 L	
10			MF2Ø #2/GNDH L	
11			MF2Ø #2/-5.2A L	
12			MF2Ø #2/GNDF L	
13			MF2Ø #2/-5.2B L	
14			MF2Ø #2/GNDE L	
15			MF2Ø #2/+5A L	
16			MF2Ø #2/GND L	
17			MF2Ø #2/+12A L	
18			MF2Ø #2/GNDC L	
19			MF2Ø #2/+5B L	
20			MF2Ø #2/GND L	
21			MF2Ø #2/+12B L	
22			MF2Ø #2/GNDA L	
23			MF2Ø #2/GNDA U	
24			MF2Ø #2/+12B U	
25			MF2Ø #2/GNDB U	
26			MF2Ø #2/+5B U	
27			MF2Ø #2/GNDC U	
28			MF2Ø #2/+12A U	
29			MF2Ø #2/GND U	
30			MF2Ø #2/+5A U	
31			MF2Ø #2/GNDE U	
32			MF2Ø #2/-5.2B U	
33			MF2Ø #2/GNDF U	
34			MF2Ø #2/-5.2A U	
35			MF2Ø #2/GNDH U	
36			MF2Ø #2/-2 U	
37			H7131 #2/-2.0V(-)L	
38			H7131 #2/-2.0V(+L)	
39			H7131 #2/-2.0V(-)U	
40			H7131 #2/-2.0V(+U)	
41			H7131 #2/+5.0V(+L)	
42			H7131 #2/+5.0V(-)L	
43			H7131 #2/+5.0V(+L)	
44			H7131 #2/+5.0V(-)L	
45			H7131 #2/+5.0V(+U)	
46			H7131 #2/+5.0V(-)U	
47			H7131 #2/+5.0V(+U)	
48			H7131 #2/+5.0V(-)U	
49			H7131 #2/+12.0V(+L)	
50			H7131 #2/+12.0V(-)L	
51			H7131 #2/+12.0V(+L)	
52			H7131 #2/+12.0V(-)L	
53			H7131 #2/+12.0V(+U)	
54			H7131 #2/+12.0V(-)U	
55			H7131 #2/+12.0V(+U)	
56			H7131 #2/+12.0V(-)U	

MF2Ø LC/LD, AC/AD

HARNESS CONNECTION CHART #10

ITEM NO.	HARNESS TERM		CONNECTION	WITH
	POINT	CONNECTION		
69		J1	MF2Ø #2/PAB1	
8			H7131 #2/TB6-2	
7			H7131 #2/TB6-3	
6			H7131 #2/TB5-3	
5			H7131 #2/TB5-2	
4			H7131 #2/TB4-3	
3			H7131 #2/TB4-2	
2			H7131 #2/TB3-2	
1			H7131 #2/TB3-3	
69		P1	H7131 #2/J1	

MF2Ø LH/LJ, LM/LN, LP/LR, LS/LT

HARNESS CONNECTION CHART #31

ITEM NO.	HARNESS TERM		CONNECTION	WITH
	POINT	CONNECTION		
5		J1	MF2Ø #1 FAN 2-1	
		J2	MF2Ø #1 FAN 2-2	
		J3	MF2Ø #1 FAN 1-1	
		J4	MF2Ø #1 FAN 1-2	
5			H7131 #1/TB2-1	
6			H7131 #1/TB2-2	
7			H7131 #1/TB2-3	
5	6		H7131 #1/TB2-4	

MF2Ø LK/LL

HARNESS CONNECTION CHART #32

ITEM NO.	HARNESS TERM		CONNECTION	WITH
	POINT	CONNECTION		
5		J1	MF2Ø #2 FAN 2-1	
		J2	MF2Ø #2 FAN 2-2	
		J3	MF2Ø #2 FAN 1-1	
		J4	MF2Ø #2 FAN 1-2	
5			H7131 #2/TB2-1	
6			H7131 #2/TB2-2	
7			H7131 #2/TB2-3	
5	6		H7131 #2/TB2-4	

MF2Ø LA/LB, LU/LV

HARNESS CONNECTION CHART #21

ITEM NO.	HARNESS TERM		CONNECTION	WITH
	POINT	CONNECTION		
61		P2	H7131 #1/J2	
61		P1	7011639 (F/E)J4	

MF2Ø LH/LJ, LM/LN, LP/LR, LS/LT

HARNESS CONNECTION CHART #33

ITEM NO.	HARNESS TERM		CONNECTION	WITH
	POINT	CONNECTION		
59	1		MF2Ø #1/GNDA U	
59	2		MF2Ø #1/12B U	
59	3		KW2Ø/JØ/P1-6	
59	4		KW2Ø/JØ/P1-7	

MF2Ø LH/LJ, LM/LN, LP/LR, LS/LT

HARNESS CONNECTION CHART #34

ITEM NO.	HARNESS TERM		CONNECTION	WITH
	POINT	CONNECTION		
57		J1	FAN 3-1	
57		J2	FAN 3-2	
57		J3	FAN 4-1	
57		J4	FAN 4-2	
57		P1	CPU CAB F1/F2-J1	
57		J5	P1*	

REVISION HISTORY

DATE	ECO NUMBER	REV.

TITLE  
MOS MEMORY

DOCUMENT NUMBER

SIZE CODE	NUMBER	REV.
DUA	MF2Ø-Ø-Ø	E

SCALE NONE SHEET 7 OF 11

THIS DRAWING AND SPECIFICATIONS HEREIN ARE THE PROPERTY OF DIGITAL EQUIPMENT CORPORATION AND SHALL NOT BE REPRODUCED OR COPIED OR USED IN WHOLE OR IN PART AS THE BASIS FOR THE MANUFACTURE OR SALE OF ITEMS WITHOUT WRITTEN PERMISSION OF DIGITAL EQUIPMENT CORPORATION.  
1979 DIGITAL EQUIPMENT CORPORATION

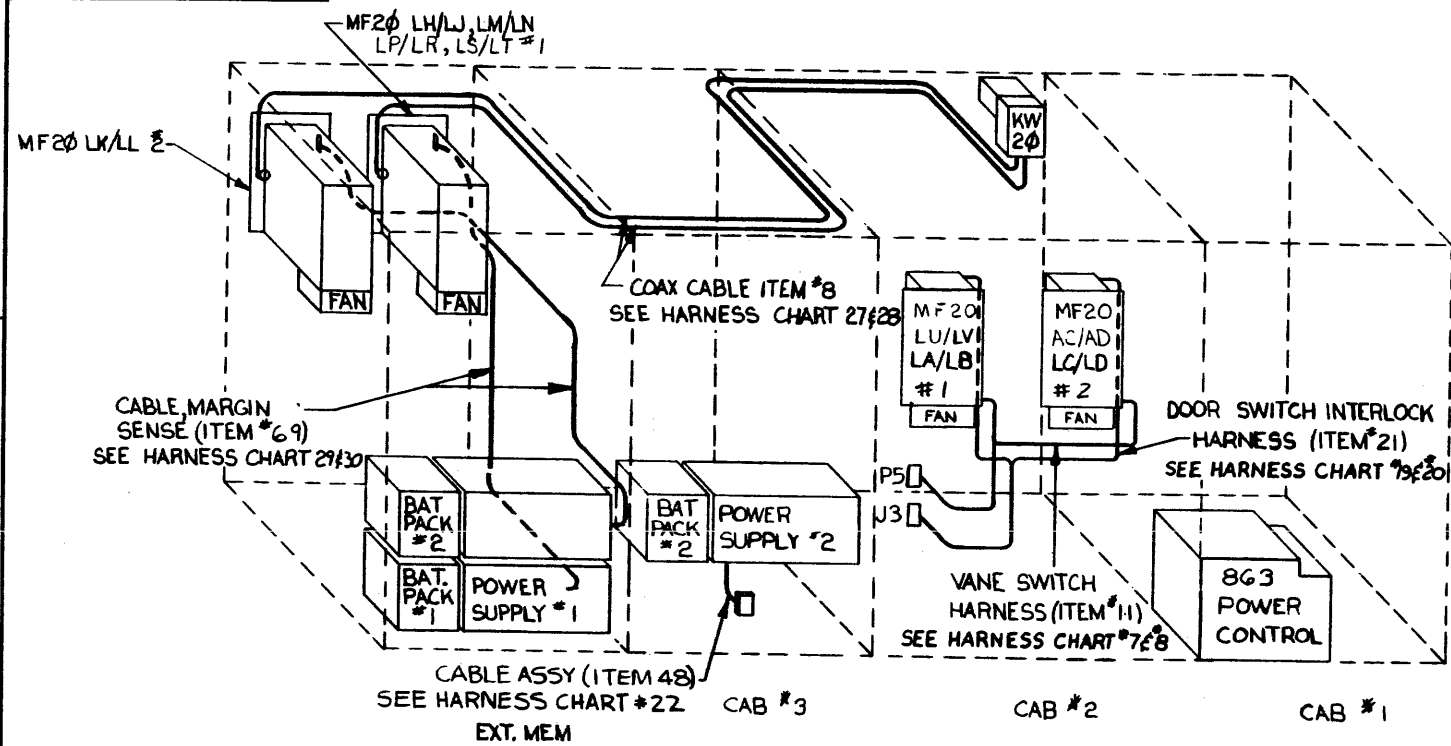

KLIØ-E REAR VIEW

MF20 LC/LD, AC/AD

HARNESS CONNECTION CHART #22				
ITEM NO.	HARNESS TERM		CONNECTION	WITH
	POINT	CONNECTION		
48		P2	H7131 #2/J2	
48		P1	H7131 #1/J3	

MF20 LH/LJ, LM/LN, LP/LR, LS/LT

HARNESS CONNECTION CHART #29				
ITEM NO.	HARNESS TERM		CONNECTION	WITH
	POINT	CONNECTION		
69		J1	MF20 #1/PAB1	
8			H7131 #1/TB6-2	
7			H7131 #1/TB6-3	
6			H7131 #1/TB5-3	
5			H7131 #1/TB5-2	
4			H7131 #1/TB4-3	
3			H7131 #1/TB4-2	
2			H7131 #1/TB3-2	
1			H7131 #1/TB3-3	
69		P1	H7131 #1/J1	

MF20 LK/LL

HARNESS CONNECTION CHART #30				
ITEM NO.	HARNESS TERM		CONNECTION	WITH
	POINT	CONNECTION		
69		J1	MF20 #2/PAB1	
8			H7131 #2/TB6-2	
7			H7131 #2/TB6-3	
6			H7131 #2/TB5-3	
5			H7131 #2/TB5-2	
4			H7131 #2/TB4-3	
3			H7131 #2/TB4-2	
2			H7131 #2/TB3-2	
1			H7131 #2/TB3-3	
69		P1	H7131 #2/J1	

MF20 LH/LJ, LM/LN, LP/LR, LS/LT

HARNESS CONNECTION CHART #27				
ITEM NO.	HARNESS TERM		CONNECTION	WITH
	POINT	CONNECTION		
8		MF20 #1 (BACKPLANE)	KW2Ø/J2	

MF20 LK/LL

HARNESS CONNECTION CHART #28				
ITEM NO.	HARNESS TERM		CONNECTION	WITH
	POINT	CONNECTION		
8		MF20 #2 (BACKPLANE)	KW2Ø/J4	

MF20 LP/LS

HARNESS CONNECTION CHART #43				
ITEM NO.	HARNESS TERM		CONNECTION	WITH
	POINT	CONNECTION		
89		P1	863/J27	
89	1		H7131 #1/TBI-GND	
89	2		H7131 #1/TBI-NEUT	
89	3		H7131 #1/TBI-LINE	

MF20 LR/LT

HARNESS CONNECTION CHART #44				
ITEM NO.	HARNESS TERM		CONNECTION	WITH
	POINT	CONNECTION		
88		P1	863/J27	
88	1		H7131 #1/TBI-GND	
88	3		H7131 #1/TBI-NEUT	
88	2		H7131 #1/TBI-LINE	

MF20 LP/LR, LS/LT

HARNESS CONNECTION CHART #45				
ITEM NO.	HARNESS TERM		CONNECTION	WITH
	POINT	CONNECTION		
83		P1	KW2Ø/JB	
83	7		H742Ø #3/J13-6	
83	8		H742Ø #3/J13-6	
83	9		MF20 #1 GNDA U	
83	10		MF20 #1 12B U	

MF20 LK/LL (ONLY IF MF20 LP/LR, LS/LT IS PRESENT)

HARNESS CONNECTION CHART #45				
ITEM NO.	HARNESS TERM		CONNECTION	WITH
	POINT	CONNECTION		
83	11		MF20 #2/GNDA U*	
83	12		MF20 #2/12B U*	
PART OF HARNESS USED FOR LP/LR, LS/LT				

MF20 LP/LR, LS/LT

HARNESS CONNECTION CHART #49				
ITEM NO.	HARNESS TERM		CONNECTION	WITH
	POINT	CONNECTION		
85		P1	MF20-LP/LR H7131 J2	
85		P2	70H639(F/E) J4	

MF20 LU/LV

HARNESS CONNECTION CHART #48				
ITEM NO.	HARNESS TERM		CONNECTION	WITH
	POINT	CONNECTION		
82	1		MF20 #1/GNDA U	
82	2		MF20 #1/12B U	
83	3		PI-4 MASTER OSC	
84	4		PI-3 MASTER OSC	

MF20 LA/LB, LU/LV

HARNESS CONNECTION CHART #7				
ITEM NO.	HARNESS TERM		CONNECTION	WITH
	POINT	CONNECTION		
11	1		MF20 #1/SW2 (-)	
11	2		MF20 #1/SW2 (L)	
11	3		MF20 #1/SW2 (+)	
		J5	FAULT HARNESS/P5	
21			MF20 #1/SW1 (-)	
22			MF20 #1/SW1 (-)	
23			MF20 #1/SW1 (L)	
24			MF20 #1/SW1 (L)	
25			MF20 #1/SW1 (+)	
11	26		MF20 #1/SW1 (+)	

MF20 LC/LD, AC/AD

HARNESS CONNECTION CHART #8				
ITEM NO.	HARNESS TERM		CONNECTION	WITH
	POINT	CONNECTION		
11	12		MF20 #2/SW2 (-)	
11	13		MF20 #2/SW2 (L)	
11	14		MF20 #2/SW2 (+)	
11	15		MF20 #2/SW1 (-)	
11	16		MF20 #2/SW1 (-)	
11	17		MF20 #2/SW1 (L)	
11	18		MF20 #2/SW1 (L)	
11	19		MF20 #2/SW1 (+)	
11	20		MF20 #2/SW1 (+)	

MF20 LA/LB, LU/LV

HARNESS CONNECTION CHART #19				
ITEM NO.	HARNESS TERM		CONNECTION	WITH
	POINT	CONNECTION		
21		J1	MF20 #1/DOOR SWITCH	
21	5		FAULT HARNESS/J3-1	
21	6		FAULT HARNESS/J3-3	

MF20 LC/LD, AC/AD

HARNESS CONNECTION CHART #20				
ITEM NO.	HARNESS TERM		CONNECTION	WITH
	POINT	CONNECTION		
21		J2	MF20 #2/DOOR SWITCH	

PART OF HARNESS USED FOR MF20-LA/LB

REVISION HISTORY

DATE	ECD NUMBER	REV.

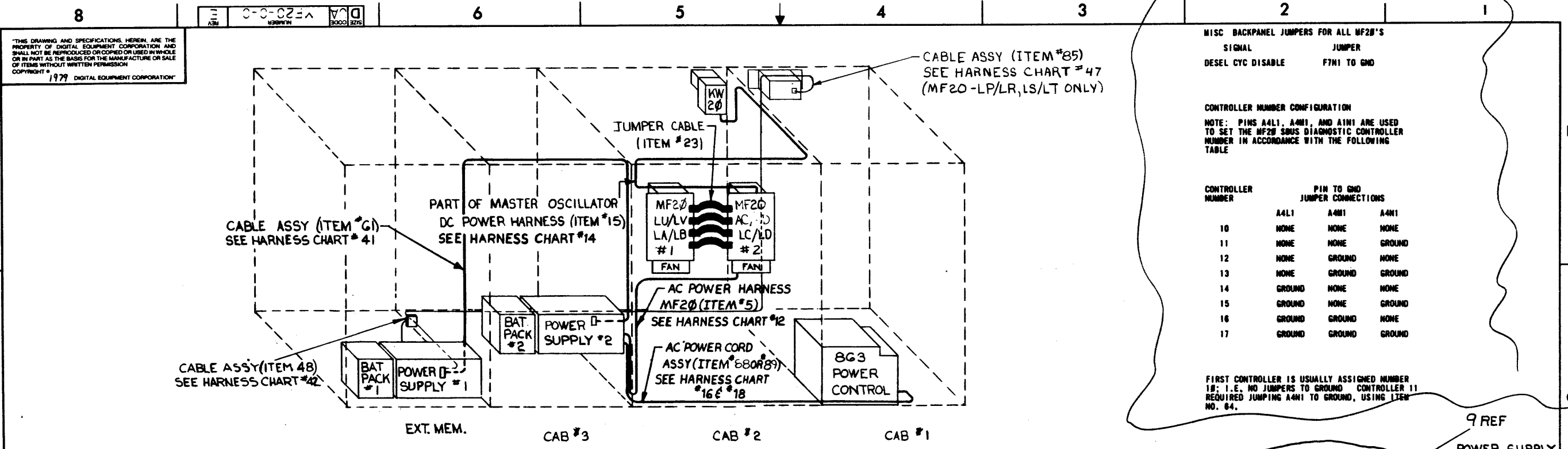

KLIØ-E REAR VIEW

MISC BACKPANEL JUMPERS FOR ALL MF20'S  
 SIGNAL JUMPER  
 DESEL CYC DISABLE F7N1 TO GND

CONTROLLER NUMBER CONFIGURATION  
 NOTE: PINS A4L1, A4M1, AND A1N1 ARE USED TO SET THE MF20 SUBS DIAGNOSTIC CONTROLLER NUMBER IN ACCORDANCE WITH THE FOLLOWING TABLE

CONTROLLER NUMBER	PIN TO GND JUMPER CONNECTIONS		
	A4L1	A4M1	A4N1
10	NONE	NONE	NONE
11	NONE	NONE	GROUND
12	NONE	GROUND	NONE
13	NONE	GROUND	GROUND
14	GROUND	NONE	NONE
15	GROUND	NONE	GROUND
16	GROUND	GROUND	NONE
17	GROUND	GROUND	GROUND

FIRST CONTROLLER IS USUALLY ASSIGNED NUMBER 10; I.E. NO JUMPERS TO GROUND. CONTROLLER 11 REQUIRED JUMPING A4M1 TO GROUND, USING ITEM NO. 64.

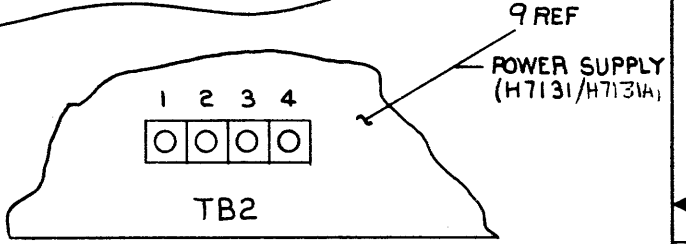

FOR 115 VAC OPERATION JUMPER TB2-1 TO TB2-2 AND TB2-3 TO TB2-4  
 FOR 240 VAC OPERATION JUMPER TB2-2 TO TB2-3 JUMPER SUPPLIED WITH POWER SUPPLY (ITEM #8).

MF20 LC/LD, AC/AD

ITEM NO.	HARNESS TERM		CONNECTION	WITH
	POINT	CONNECTION		
8		J1	MF20 #2 FAN 2-1	
		J2	MF20 #2 FAN 2-2	
		J3	MF20 #2 FAN 1-1	
		J4	MF20 #2 FAN 1-2	
5			H7131 #2/TB2-1	
6			H7131 #2/TB2-2	
7			H7131 #2/TB2-3	
8			H7131 #2/TB2-4	

MF20 LD, AD

ITEM NO.	HARNESS TERM		CONNECTION	WITH
	POINT	CONNECTION		
88		P1	863/J24	
88	1		H7131 #2/TB 1-GND	
88	3		H7131 #2/TB 1-NEUT	
88	2		H7131 #2/TB 1-LINE	

MF20 LC/LD, AC/LD

ITEM NO.	HARNESS TERM		CONNECTION	WITH
	POINT	CONNECTION		
15	11		MF20 #2/GNDA U	
15	12		MF20 #2/ 12B U	

PART OF HARNESS USED FOR MF20-LA/LB

MF20 LC, AC

ITEM NO.	HARNESS TERM		CONNECTION	WITH
	POINT	CONNECTION		
89		P1	863/J24	
89	1		H7131 #2/TB 1-GND	
89	3		H7131 #2/TB 1-NEUT	
89	2		H7131 #2/TB 1-LINE	

MF20 LM/LJ, LM/LN

ITEM NO.	HARNESS TERM		CONNECTION	WITH
	POINT	CONNECTION		
81		P2	H7131 #1/J2	
81		P1	MF20-LC/LD H7131 #2/J3 -AC/AC	

MF20 LL/LK

ITEM NO.	HARNESS TERM		CONNECTION	WITH
	POINT	CONNECTION		
48		P2	H7131 #2/J2	
48		P1	H7131 #1/J3	

REVISION HISTORY		
DATE	ECO NUMBER	REV.



UNCLASSIFIED

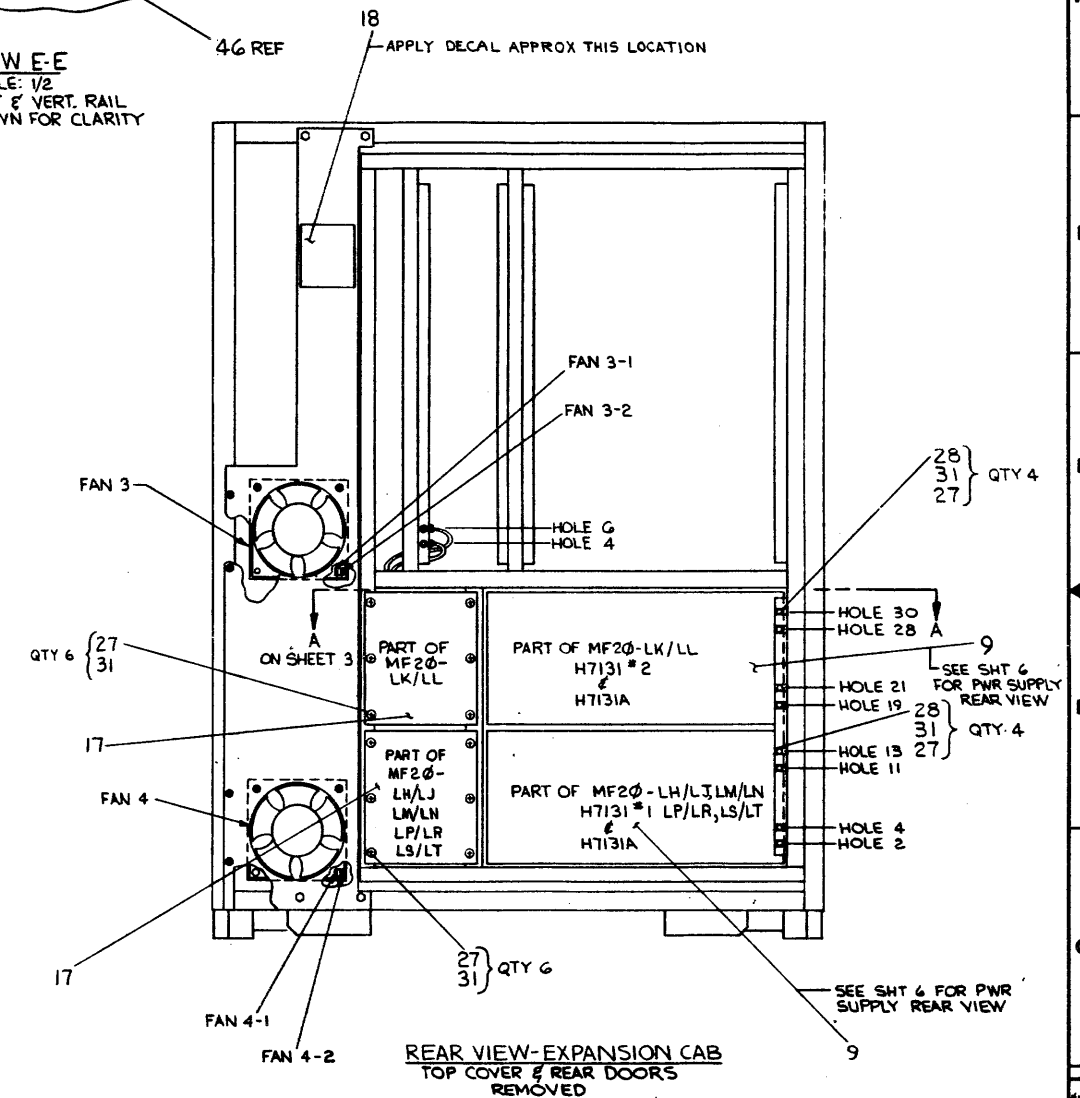
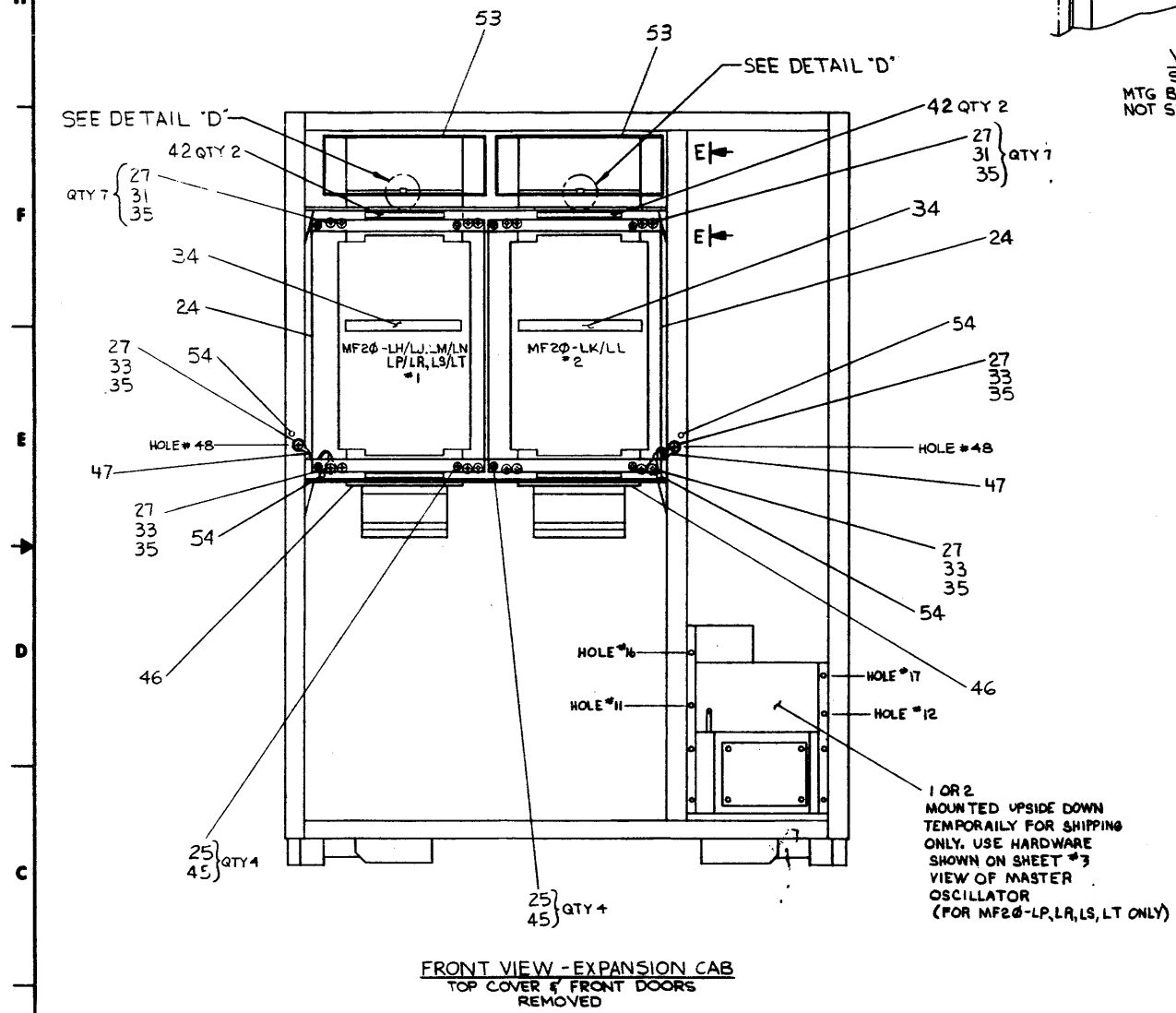
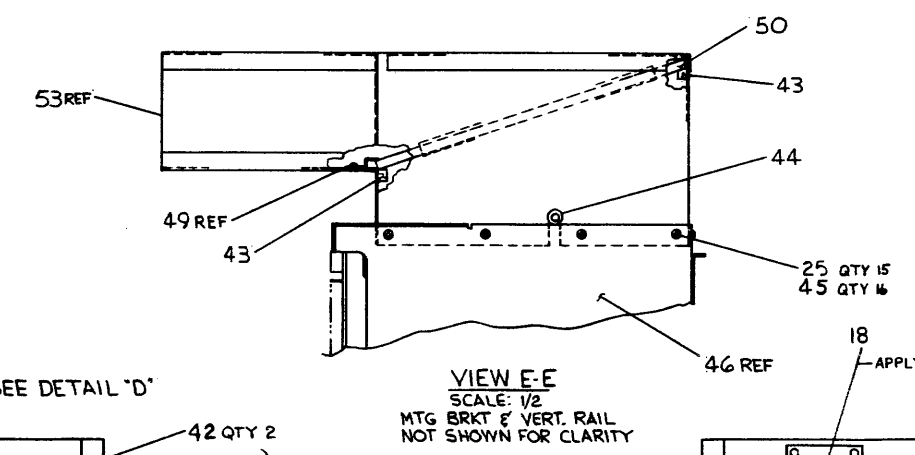
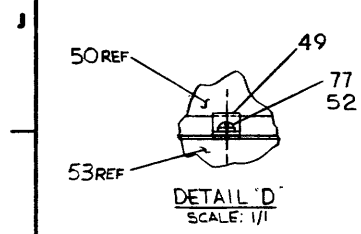

MF20-LH, LJ, LK, LL, LM, LN, LP, LR, LS, LT

AUTOMATED BY PRTLST.3P(44)

PARTS LIST

SHEET A1 OF A2

LINE	ITEM	TOP DOCUMENT	PART NUMBER	MIN REV	DESCRIPTION	VARIATION LEVEL:			
						LA	LB	LC	LD
1	1	E-UA-KW20-0-0	KW20 -A		OSCILLATOR ASSY MASTER 60HZ	1	-	-	-
2	2	E-UA-KW20-0-0	KW20 -B		OSCILLATOR ASSY MASTER 50HZ	-	1	-	-
3	3	J-IA-7015189-0-0	7015189-00		HARNESS DC POW 2ND MF20	-	-	1	1
4	5	E-IA-7015222-0-0	7015222-00		HARNESS MF20 AC POWER	1	1	1	1
5	6	E-IA-7014470-0-0	7014470-00		WELDMENT, TOP DUCT	1	1	1	1
6	7	D-UA-5412855-0-0	5412855-00		XBUS TERMINATOR	4	4	-	-
7	8		1700100-00		CABLE, COAX, ASSY W/CONN	2	2	1	1
8	9	A-PS-3014903-0-0	3014903-00		POWER SUPPLY, MULTIPLE OUTPUT	1	1	1	1
9	10	D-IA-7015104-0-0	7015104-01		WELDMENT AIR DUCT, EX	1	1	-	-
10	11	D-IA-7015447-0-0	7015447-00		HARNESS VANE SWITCH	1	1	-	-
11	12	D-IA-7015104-0-0	7015104-00		WELDMENT AIR DUCT EX	-	-	1	1
12	13	D-IA-7419818-0-0	7419818-00		BRACKET PUR SUPPLY	1	1	1	1
13	14	D-IA-7015448-0-0	7015448-00		HARNESS MASTER OSC AC POWER MF20	1	1	-	-
14	15	D-IA-7015471-0-0	7015471-00		HARNESS DC MASTER OSC	1	1	-	-
15	17	E-AD-7015075-0-0	7015075-00		BATTERY BOX ASSY	1	1	1	1
16	18	D-MD-7419341-0-0	7419341-00		MOUNT RAIL MF20	2	2	-	-
17	19		1214045-02		FILTER, AIR ALUM FRAMED	1	1	1	1
18	21	D-IA-7015453-0-0	7015453-00		HARNESS DOOR INTERLOCK SWITCH	1	1	-	-
19	23		1700101-00		CABLE, COAX, ASSY, 1 FT W/CONN	0	-	4	4
20	24	C-MD-7420656-0-0	7420656-00		SHIELD BACKPLANE	1	1	1	1
21	25		9006037-03		SCREW, MACH TRUSS PHIL 8-	23	23	23	23
22	27		9006074-03		SCREW, MACH TRUSS PHIL 10-	43	43	29	29
23	28		9007786-00		RETAINER, U-NUT 10-32X	16	16	12	12
24	29	D-UA-M8572-0-0	M8572-00		MULTIPLE S-BUS TRANSLATOR, 4 LAY	1	1	-	-
25	30	J-IA-7015671-0-0	7015671-00		HARNESS DC MAIN NO 1 MF20	1	1	-	-
26	31		9006635-00		WASHER, LOCK INTERNAL STEEL	39	39	27	27
27	32	C-IA-7013059-0-0	7013059-02		GROUND STRAP	1	1	1	1
28	33		9007651-00		WASHER, LOCK EXTERNAL STEEL	5	5	4	4
29	34	A-SP-3615087-0-0	3615087-02		LABEL, "DANGER-HIGH CURRENT"	1	1	1	1
30	35		9006565-00		NUT, HEX EXT TOOTH LCKWSHR 10-32	12	12	11	11

*bolt 2  
50HZ*

*1700101-00*

REVISION HISTORY			BASIC PART NO: MF20	
ENG	ECO NUMBER	REV	SECTION A OF A	DRN: G. FLANDERS
			SECTION VARIATION INDEX	DATE: 14 DEC 83
	INITIAL	A	(A) LA, LB, LC, LD	CHK'D: G. FLANDERS
			(B)	DATE: 14 JUN 84
			(C)	DES. ENG: B. EICHMANN
			(D)	DATE: 14 JUN 84
			(E)	RESP. ENG.: B. EICHMANN
			(F)	DATE: 14 JUN 84
				MFG. ENG.: GERRY EMOND
				DATE: 15 JUN 84
				ASSEMBLY NUMBER: #NONE
				TOP DOCUMENT NUMBER: K-PL-MG20-L-DPB
				FILE NAME: Z8507A.PLS
				RELEASE DATE: 19-JUN-84
				EDIT #: 41

"THIS DRAWING AND THE SPECIFICATIONS CONTAINED HEREIN ARE CONFIDENTIAL AND PROPRIETARY. THEY ARE THE PROPERTY OF DIGITAL EQUIPMENT CORPORATION AND SHALL NOT BE REPRODUCED OR COPIED OR USED IN WHOLE OR IN PART AS THE BASIS FOR THE MANUFACTURE OR SALE OF ITEMS WITHOUT WRITTEN PERMISSION. THIS IS AN UNPUBLISHED WORK PROTECTED UNDER THE FEDERAL COPYRIGHT LAWS."

LINE	ITEM	TOP DOCUMENT	PART NUMBER	MIN REV	DESCRIPTION	QTY PER VARIATION			
						LA	LB	LC	LD
					VARIATION REVISION LEVEL:	A1	A1	A1	A1
31	36	K-PL-MG20-E-DBP	MG20 -E		4 MG20-M (M8570-AA) [1MW]	1	1	1	1
32	37	E-UA-M8574-0-0	M8574-00		WRITE PATH	1	1	1	1
33	38	E-UA-M8575-0-0	M8575-00		SYNDROME MF20	1	1	1	1
34	39	E-UA-M8576-0-0	M8576-00		MOS CONTROL	1	1	1	1
35	40	E-UA-M8577-0-0	M8577-00		ADDRESS + TIME MF20	1	1	1	1
36	41	D-UA-M8580-0-0	M8580-00		TRANSLATOR DUAL MF20	2	2	-	-
37	42	A-DC-7420961-0-0	7420961-00		DECAL BACKPLANE	2	2	2	2
38	43		9008274-00		FOAM, TAPE 3/8" X 3/8" BLACK	A/R	A/R	A/R	A/R
39	44		9007017-00		GROMMET, ROUND RUBBER	1	1	1	1
40	45		9006634-00		WASHER, LOCK INTERNAL STEEL	24	24	24	24
41	46	E-AD-7016018-0-0	7016018-01		CARD CAGE ASSY	1	1	1	1
42	48	C-IA-7008288-0-0	7008288-3F		CABLE ASSY	0	-	1	1
43	54		3613272-00		LABEL, ADH BACK, MYLAR CAP	4	4	4	4
44	61	C-IA-7008288-0-0	7008288-15		CABLE ASSY	1	1	-	-
45	64	B-UA-915-0-0	00915-03		JUMPER CORD	4	4	4	4
46	68		9007033-00		TIE, CABLE BUNDL. DIA 0-1-3/4"=101	A/R	A/R	A/R	A/R
47	69	E-IA-7015190-0-0	7015190-7M		CABLE MARGIN SENSE MF20	1	1	1	1
48	72	A-PS-3613211-0-0	3613211-00		DECAL, CLEAR PREPRINTED CSA 1-1/4	REF	REF	REF	REF
49	73	A-PS-3612449-0-0	3612449-00		LABEL, UL. FOIL VINYL, ADH BACK,	REF	REF	REF	REF
50	74	A-PS-3615180-0-0	3615180-00		/REPLACED BY 36-17674-00	1	1	1	1
51	75	D-IA-7015524-0-0	7015524-8F		CABLE CLOCK SELECT	1	1	-	-
52	76	C-IA-7013059-0-0	7013059-06		GROUND STRIP	1	1	1	1
53	80	B-PL-MG20-0-SH			FOR MFG PLANNING	REF	REF	REF	REF
54	87	A-SP-3700258-0-0	3700258-00		INSTR PKG MA20-AC	REF	REF	REF	REF
55	88	D-IA-7015449-0-0	7015449-YB		POWER CORD ASSY AC 50HZ 12 1/2 F	-	1	-	1
56	89	D-IA-7015450-0-0	7015450-YB		POWER CORD ASSY AC 60HZ 12 1/2 F	1	-	1	-
57	90		9007086-00		CLAMP, CABLE, SCREW MTD. 9/16"	1	1	1	1
58	91		9006039-03		SCREW, MACH TRUSS PHIL 8-	1	1	1	1

59 NOTE: 1. CAUTION THIS PARTS LIST IS NOT IN NUMERICAL  
 60 NOTE: SEQUENCE. REFER TO E-UA-MF20-0-0 TO ASSEMBLE  
 61 NOTE: THIS SYSTEM.

D	I	G	I	T	A	L	TITLE	MOS MEMORY MG20-L	SECTION A	OF	A	SIZE	CODE	DOCUMENT NUMBER	REV
												K	PL	MG20-L-DBP	A



DIGITAL EQUIPMENT CORPORATION  
MAYNARD, MASSACHUSETTS

PARTS LIST

MADE BY *R. Charles* CHECKED *J. F. Landon* SECTION  
 DATE 3 JAN 78 DATE 3 JAN 78 ISSUED SECT. 1  
 ENG R. Charles PROD J. Charles  
 DATE 27 JULY 78 DATE 27 JULY 78

ITEM NO.	DWG NO./PART NO.	DESCRIPTION
1	D-IA-7419342-0-0	BRKT, OSCILLATOR PANEL
2	D-IA-7419340-0-0	COVER, DUST
3	D-IA-7419343-0-0	BRACKET MOUNTING RT
4	C-IA-7419345-0-0	BRACKET MTG LEFT
5	C-MD-7419344-0-0	COVER ACCESS
6	D-UA-5412851-0-0	MASTER OSCILLATOR
7	1209403-02	FAN, 115 VAC 50/60 HZ
8	1210263-00	GUARD FINGER MUF FAN
9	9006035-01	SCREW, PAN, PHIL, 8-32 x .25 SS/PAS
10	9008151-00	WASHER, LOCK EXT. TOOTH #8
11	9006019-01	SCREW, PAN, PHIL, 8-32 x .50 SS/PAS
12	9006713-00	WASHER, NYLON, FLAT #8 4370.D.X.032 THK
13	9007793-01	SCREW, PAN, PHIL, 6-32 x .56 SS/PAS
14	9007649-00	WASHER, LOCK, EXTERNAL TOOTH #6
15	9006560-00	NUT, KEP, 6-32 x .31 AF
16	9008198-00	FASTENER STUD, 1/4 TURN, OVAL HD
17	9008200-00	RETAINER
18	9009151-00	RECEPTACLE CLIP-ON
19	1210930-02	FAN, 230V, 50HZ/60HZ
20	9006022-01	SCREW, PAN, PHIL, 6-32 x .38 SS/PAS
21	9006653-00	WASHER, FLAT, .375 O.D.X.156I.D.X.036
22	9008894-02	TAPE

TITLE  
 MASTER OSCILLATOR ASSY KW20  
 ASSY NO. E-UA-KW20-0-0  
 SIZE A PL  
 SHEET 1 OF 2  
 DIST

ECO NO. KW20-MR002  
 REV B  
 NUMBER KW20-0-0  
 QUANTITY VARIATION

DEC FORM DRA 110

M/R

DIGITAL EQUIPMENT CORPORATION  
MAYNARD, MASSACHUSETTS

PARTS LIST

MADE BY *R. Charles* CHECKED *J. F. Landon* SECTION  
 DATE 3 JAN 78 DATE 3 JAN 78 ISSUED SECT. 1  
 ENG R. Charles PROD J. Charles  
 DATE 27 JULY 78 DATE 27 JULY 78

ITEM NO.	DWG NO./PART NO.	DESCRIPTION
23	B-MD-7419825-0-0	STRAIN RELIEF COAX CONN
24	9006724	WASHER, LOCK, EXT. TOOTH .25
25	9008203	NUT, KEP. 1/4-20
26	7013059-6	STRAP, GROUND
27	7008274	TAPE .38 X.38
28	9006690-00	WASHER, LOCK, S.S. # 8
29	9006660-00	WASHER, FLAT .375 O.D. X .187 I.D. X.036 THK
30	9009255-00	LABEL, P.S. 2 1/16 X 1
31	9006037-01	SCREW, PAN PHIL 8-32 x.38 SS/PAS
32	9006026-01	SCREW, PAN PHIL 6-32 x.75 SS/PAS
33	9006025-01	SCREW, PAN PHIL 6-32 x.62 SS/PAS
34	7013059-4	STRAP GROUND

TITLE  
 MASTER OSCILLATOR ASSY KW20  
 ASSY NO. E-UA-KW20-0-0  
 SIZE A PL  
 SHEET 2 OF 2  
 DIST

ECO NO. KW20-MR002  
 REV B  
 NUMBER KW20-0-0  
 QUANTITY VARIATION

DEC FORM DRA 110

M/R



DIGITAL EQUIPMENT CORPORATION  
MAYNARD, MASSACHUSETTS

PARTS LIST

MADE BY: *J. Smith*  
 DATE: 12 JAN 78  
 ENG: *R. G. Smith*  
 DATE: 27 JULY 78  
 CHECKED: *R. G. Smith*  
 DATE: 14 JUL 78  
 PROD: *R. G. Smith*  
 DATE: 27 JULY 78

ITEM NO.	DWG NO./PART NO.	DESCRIPTION	SECTION	ISSUED SECT.	QUANTITY VARIATION
1	D-IA-7014466-0-0	WELDMENT BATTERY BOX	1	1	7015075-0
2	D-IA-7014467-0-0	WELDMENT TOP COVER			
3	D-IA-7014468-0-0	REAR COVER WELDMENT			
4	1211498-00	CKT BKR 35.0 A 5ØV 1P			
5	1214958-00	MOUNTING ADAPTER RED			
6	1214944-01	CONN HOUSING, PWR LOCK 3ØA (RED)			
7	1214949-00	CONTACT			
8	1214997-00	BATTERY			
9	A-DC-7420230-0-0	DECAL BATTERY BOX			
10	9009255-00	LABEL, POWER SUPPLY, 2-15/16" LG x 1" WID			
11	9107380-99	WIRE, STRND, 12AWG, (WHT)	A/R		
12	9007926-01	TERM RING	2		
13	9006036-01	SCREW, PAN, PHIL, 8-32 x .31	4		
14	<del>9006016-01</del>	<del>SCREW, PAN, PHIL, 4-40 x .88</del>	16		
15	9006020-01	SCREW, PAN, PHIL, 6-32 x .25	4		
16	9006557-00	NUT, KEP, 4-40	16		
17	9006634-00	WASHER, LOCK, INT, .23ØODx.172IDx.025THK	4		
18	9006633-00	WASHER, LOCK, INT, .28ØODx.146IDx.018THK	16		
19	D-IA-7015223-0-0	HARNES BATTERY BOX	1		
20	1214944-00	CONN HOUSING, PWER LOCK 3ØA (BLK)	8		
21	1211198-02	STRAIN RELIEF POWER CORD	1		
22	9009309-01	LOCK NUT	1		

TITLE: BATTERY BOX ASSY MF2Ø  
 ASSY NO.: E-AD-7015075-0-0  
 SIZE: A PL  
 CODE: PL  
 NUMBER: 7015075-0-0  
 REV: B  
 ECO NO.: MF2Ø - MROØØ  
 SHEET 1 OF 2  
 DIST: MZ

DIGITAL EQUIPMENT CORPORATION  
MAYNARD, MASSACHUSETTS

PARTS LIST

MADE BY: *J. Smith*  
 DATE: 12 JAN 78  
 ENG: *R. G. Smith*  
 DATE: 27 JULY 78  
 CHECKED: *R. G. Smith*  
 DATE: 14 JUL 78  
 PROD: *R. G. Smith*  
 DATE: 27 JULY 78

ITEM NO.	DWG NO./PART NO.	DESCRIPTION	SECTION	ISSUED SECT.	QUANTITY VARIATION
23	9006021-01	SCR PHC PAN HD #6-32 x .31			7015075-0
24	<del>9006059-0</del>	<del>STRAP, GROUND</del>			
25	9008203	NUT, KEP 4-20	1		
26	9006724	WASHER, EXT, TOOTH LOCK	1		
27	9006015-01	SCR, PHIL. PAN HD. #4-40 x .75	16		
28	<del>7Ø13Ø59-4</del>	<del>STRAP, GROUND</del>	1		
29	7Ø13Ø59-8	STRAP, GROUND	1		

TITLE: BATTERY BOX ASSY MF2Ø  
 ASSY NO.: E-AD-7015075-0-0  
 SIZE: A PL  
 CODE: PL  
 NUMBER: 7015075-0-0  
 REV: B  
 ECO NO.: MF2Ø - MROØØ  
 SHEET 2 OF 2  
 DIST: MZ

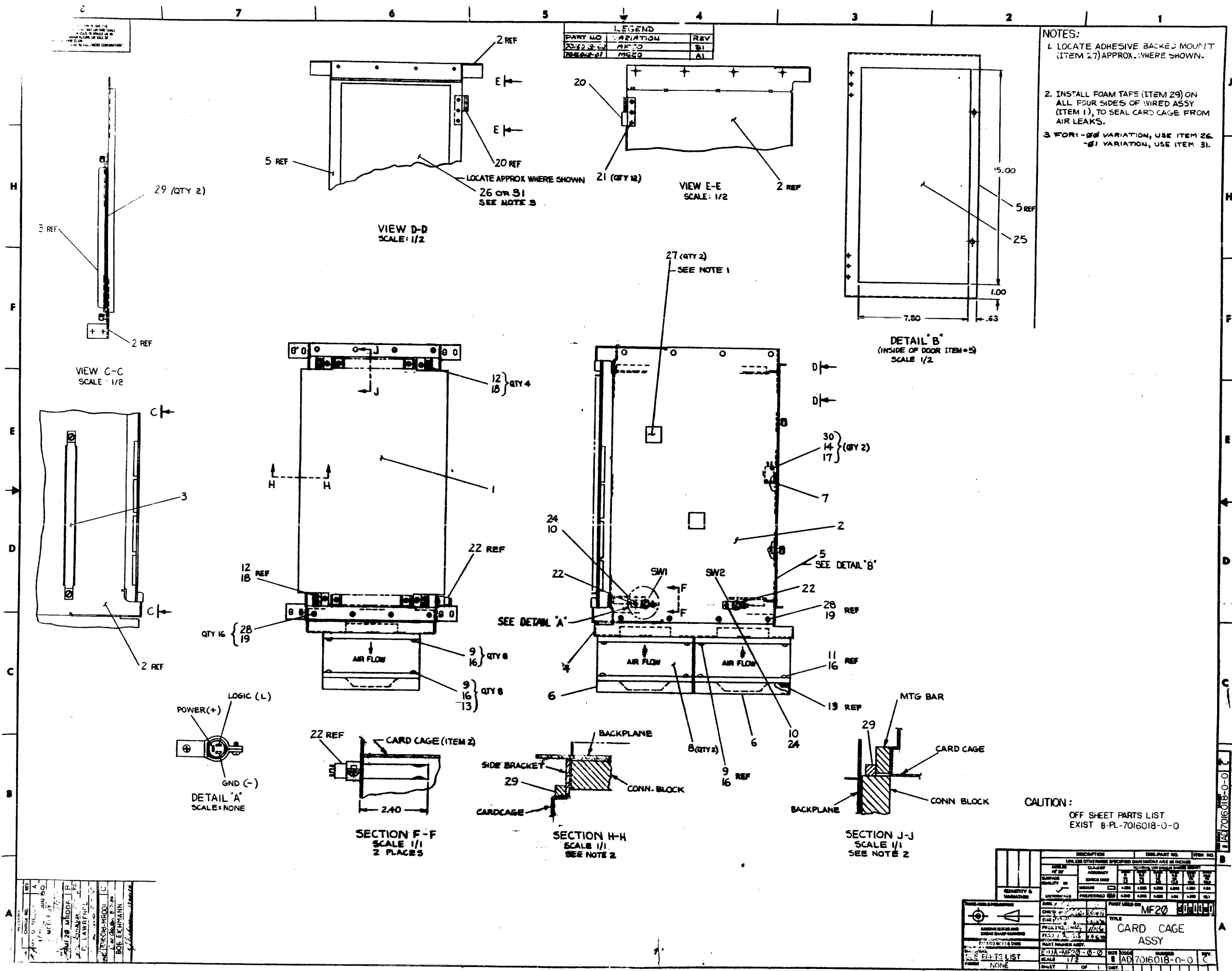

LINE ITEM	TOP DOCUMENT	PART NUMBER	MIN REV	DESCRIPTION	QTY PER VARIATION		
					00	01	
				VARIATION REVISION LEVEL:	B1	A1	
1	1	E-AD-7014358-0-0		7014358-00	WIRED ASSY-MF20	1	1
2	2	E-IA-7014127-0-0		7014127-00	WELDMENT,CARD CAGE	1	1
3	3	C-IA-7419820-0-0		7419820-00	CABLE CLAMPS	1	1
4	4	D-IA-7420668-0-0		7420668-00	MOUNT,FAN	1	1
5	5	D-IA-7419083-0-0		7419083-00	PANEL FRONT DOOR	1	1
6	6	D-IA-7012686-0-0		7012686-00	FINGER GUARD	2	2
7	7			1210755-00	SW,LEVER 1PST 11A277VAC	1	1
8	8			1211747-00	FAN,TUBE AXIAL 7.0" 350CFM 115V	2	2
9	9			9006075-01	SCREW,MACH PAN PHIL 10-	16	16
10	10			9006022-01	SCREW,MACH PAN PHIL 6-	2	2
11	11			9006074-01	*** THIS ITEM IS NOT USED ***	-	-
12	12			9006074-03	SCREW,MACH TRUSS PHIL 10-	4	4
13	13			9007786-00	RETAINER,U-NUT 10-32X	8	8
14	14			9006557-00	NUT,HEX EXT TOOTH LCKWSHR 4-40	2	2
15	15			9006013-01	*** THIS ITEM IS NOT USED ***	-	-
16	16			9006635-00	WASHER,LOCK INTERNAL STEEL	16	16
17	17			9006632-00	WASHER,LOCK INTERNAL STEEL	2	2
18	18			9007651-00	WASHER,LOCK EXTERNAL STEEL	4	4
19	19			9006634-00	WASHER,LOCK INTERNAL STEEL	16	16
20	20	B-MD-7420769-0-0		7420769-00	HINGE,SLIP R.H.(REWORK)	2	2
21	21			9006458-00	RIVET,BLIND DONE 0.125DX0.275	12	12
22	22			1215413-00	SW,SOLID STATE VANE	2	2
23	23			9007834-00	*** THIS ITEM IS NOT USED ***	-	-
24	24			9006633-00	WASHER,LOCK INTERNAL STEEL	2	2
25	25			9008479-01	FOAM POLYURETHANE	A/R	A/R
26	26			3615747-00	LABEL,ADHESIVE BACK,MF20-L MODUL	1	-
27	27			9008264-00	MOUNT, CABLE TIE, ADHESIVE BACKE	2	2
28	28			9006037-03	SCREW,MACH TRUSS PHIL 8-	16	16
29	29			9008274-00	FOAM, TAPE 3/8" X 3/8" BLACK	A/R	A/R
30	30			9006014-01	SCREW,MACH PAN PHIL 4-	2	2

REVISION HISTORY			BASIC PART NO: 7016018				
ENGI	ECO NUMBER	REV	SECTION A OF A	DRN:	BOB PELLERIN	DATE: 13-JUN-78	D I G I T A L
BE	7016018-MR01A	C	SECTION.VARIATION INDEX	CHK'D:	G. FLANDERS	DATE: 13-JUN-78	TITLE PARTS LIST
			[A]00,01				CARD CAGE ASSY
			[B]	DES.ENG:	J. MCELROY	DATE: 14-AUG-78	DOCUMENT NUMBER
			[C]				SIZE CODE  NUMBER   REV
			[D]	RESP.ENG.:	J. MCELROY	DATE: 14-AUG-78	K   PL   7016018-0-DBP   C
			[E]				
			[F]	MPG.ENG.:	L. QUARLES	DATE: 11-AUG-78	RELEASE DATE: 17-MAY-84
				ASSEMBLY NUMBER:	E-AD-7016018-0-0	TOP DOCUMENT NUMBER:	E-AD-7016018-0-0
						FILE NAME:	Z9010C.PLS
						EDIT #	3

"THIS DRAWING AND THE SPECIFICATIONS CONTAINED HEREIN ARE CONFIDENTIAL AND PROPRIETARY. THEY ARE THE PROPERTY OF DIGITAL EQUIPMENT CORPORATION AND SHALL NOT BE REPRODUCED OR COPIED OR USED IN WHOLE OR IN PART AS THE BASIS FOR THE MANUFACTURE OR SALE OF ITEMS WITHOUT WRITTEN PERMISSION. THIS IS AN UNPUBLISHED WORK PROTECTED UNDER THE FEDERAL COPYRIGHT LAWS."

MRO

AUTOMATED BY PRTLST.5R(55)

P A R T S L I S T

SHEET A2 OF A2

LINE ITEM TOP DOCUMENT

MIN  
PART NUMBER REV DESCRIPTION

QTY PER VARIATION

VARIATION REVISION LEVEL:

00 01  
B1 A1

31 31

3615747-01

LABEL,MODULE REVISION HISTORY MG

- 1

D	I	G	I	T	A	L	TITLE	CARD CAGE	SECTION A OF A	SIZE	CODE	DOCUMENT NUMBER	REV
								ASSY				7016018-0-DBP	C

MRO

THIS DRAWING AND SPECIFICATIONS ARE THE PROPERTY OF DIGITAL EQUIPMENT CORPORATION AND SHALL NOT BE REPRODUCED OR COPIED IN WHOLE OR IN PART AS THE BASIS FOR THE MANUFACTURE OR SALE OF ANY EQUIPMENT WITHOUT THE WRITTEN PERMISSION OF DIGITAL EQUIPMENT CORPORATION.

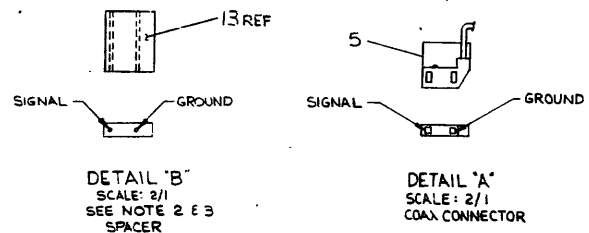

COAX JUMPER TABLE					
ITEM NO	SIGNAL FROM	GND	SIGNAL TO	GND	REMARKS
5	A07R1	A07T1	C04R2	C04N2	
	A07H2	A08H1	C06R2	C06N2	
	A07E2	A07C2	C05R2	C05N2	
	A07E1	A07H1	D07R2	D07N2	
	C07C1	D07C2	C08R2	C08N2	
	C07T2	C08T1	C09R2	C09N2	
	C07R1	C07T1	C10R2	C10N2	
	C07H2	C08H1	C11R2	C11N2	
	C07E2	C07C2	C12R2	C12N2	
	A07C1	A06C2	A22W1	A22N2	SEE DRAWING
	C07E1	C07H1	C13R2	C13N2	
	C07C1	C06C2	C14R2	C14N2	
	B07T2	B07T1	C15R2	C15N2	
	B07N1	B07N2	C16R2	C16N2	
	B07H2	B08H1	C17R2	C17N2	
	B07E1	B07H1	C18R2	C18N2	
	B07C1	B07C2	C19R2	C19N2	
	A07T2	A08T1	D05R2	D05N2	
5	A07R2	A07N2	C07R2	C07N2	

- NOTES:
- FOR N.C. WIRE WRAPPING USE PALLET 960658-0-0
  - INSTALL SPACERS (ITEM #13) IN PLACE OF COAX JUMPERS (ITEM #5) BEFORE WIRE WRAP ACCORDING TO COAX JUMPER TABLE. SPACERS TO BE INSTALLED WITH SIGNAL AND GROUND POSITIONS AS SHOWN IN DETAIL 'B'
  - AFTER WIRE WRAP BEFORE AWT, REPLACE SPACER (ITEM #13), ADDED PER NOTE 2, WITH COAX JUMPERS (ITEM #5). SEE DETAIL 'A' FOR SIGNAL & GROUND POSITIONS.
  - AFTER INSTALLATION OF COAX JUMPERS (ITEM #5) DRESS WIRES DOWN BETWEEN BACKPLANE PINS.
  - ITEM #15 (TERMINAL BLOCK) AND ITEM #4 (LED) ARE TO BE INSTALLED AFTER FINAL AWT.

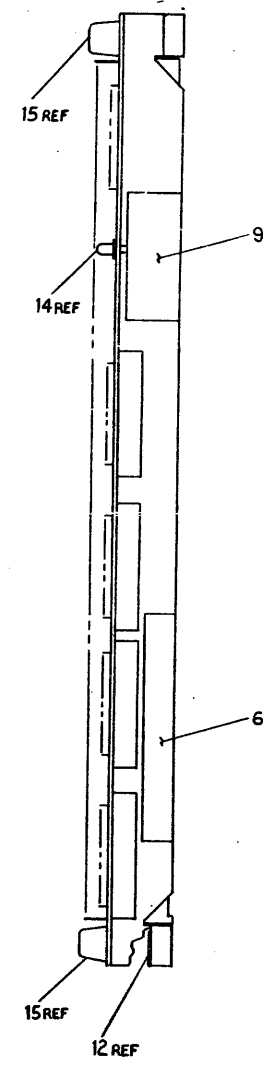
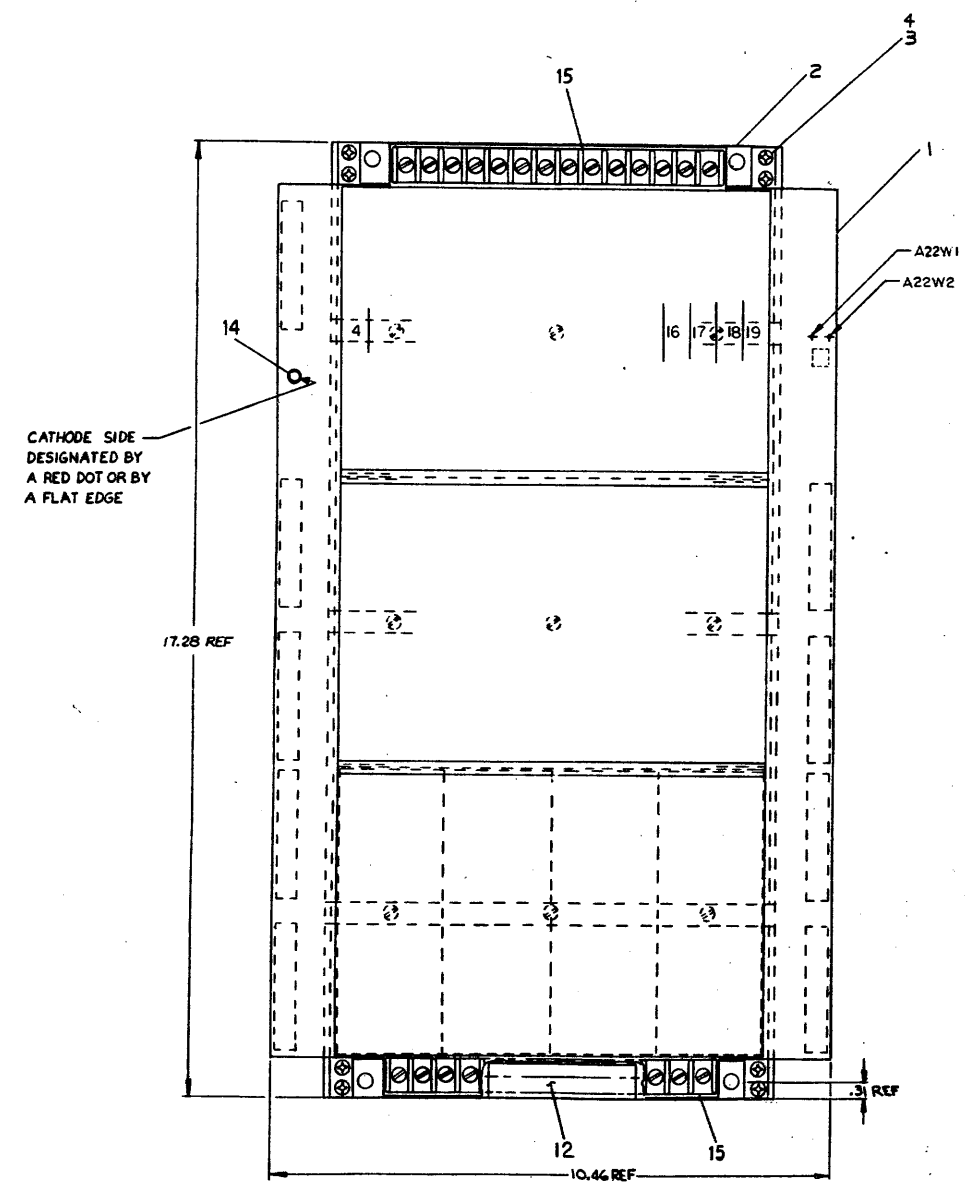

QTY.	DESCRIPTION	PART NO.	REF. NO.
1	PACKAGING INSTRUCTIONS	A-PL-370004C-04	10
2	TERM. BL. 14POS	1214057	3
1	LED	1110324	4
REF	SPACER, COMM. BLOCK	C-MD-WH7282-0-0	13
1	LABEL, ALUMINUM	900841-01	12
A/R	WIRE, MS SOLID 28AWG (GRY)	9107769-88	11
A/R	WIRE, MS SOLID 28AWG (WH)	9107768-37	10
1	LABEL, ADHESIVE BACK	9009255	9
REF	WIRE LIST	K-WL-MF20-Q-WL	8
REF	AWT REV STATUS	A-WI-704358-0	7
1	DECAL, LOGIC ASSY REVISION	A-DC-711881-1-0	6
19	COAX JUMPER	1700039	5
B	WASHER, LOCK W/ TOOTH	9004634	4
B	SCR, PHL PAN HD 9-32x30	9006034-1	3
Z	BAR, TOP & BOTTOM	D-MD-711881-0-0	2
1	BACKPLANE ASSY MF20	E-AD-704355-0-0	1

FIRST USED ON OPTOBOARD		PARTS LIST	
DATE	BY	QTY	PART NO.
10/27/72	...	1	1110324
10/27/72	...	1	1700039
10/27/72	...	1	1214057
10/27/72	...	1	900841-01
10/27/72	...	1	9107769-88
10/27/72	...	1	9107768-37
10/27/72	...	1	9009255
10/27/72	...	1	K-WL-MF20-Q-WL
10/27/72	...	1	A-WI-704358-0
10/27/72	...	1	A-DC-711881-1-0
10/27/72	...	19	1700039
10/27/72	...	2	9004634
10/27/72	...	2	9006034-1
10/27/72	...	1	D-MD-711881-0-0
10/27/72	...	1	E-AD-704355-0-0

MF20

WIRE LIST

DATE: 10/27/72

BY: [Signature]

QTY: 1

PART NO.: 1110324

DATE: 10/27/72

BY: [Signature]

QTY: 1

PART NO.: 1700039

DATE: 10/27/72

BY: [Signature]

QTY: 1

PART NO.: 1214057

DATE: 10/27/72

BY: [Signature]

QTY: 1

PART NO.: 900841-01

DATE: 10/27/72

BY: [Signature]

QTY: 1

PART NO.: 9107769-88

DATE: 10/27/72

BY: [Signature]

QTY: 1

PART NO.: 9107768-37

DATE: 10/27/72

BY: [Signature]

QTY: 1

PART NO.: 9009255

DATE: 10/27/72

BY: [Signature]

QTY: 1

PART NO.: K-WL-MF20-Q-WL

DATE: 10/27/72

BY: [Signature]

QTY: 1

PART NO.: A-WI-704358-0

DATE: 10/27/72

BY: [Signature]

QTY: 1

PART NO.: A-DC-711881-1-0

DATE: 10/27/72

BY: [Signature]

QTY: 19

PART NO.: 1700039

DATE: 10/27/72

BY: [Signature]

QTY: 2

PART NO.: 9004634

DATE: 10/27/72

BY: [Signature]

QTY: 2

PART NO.: 9006034-1

DATE: 10/27/72

BY: [Signature]

QTY: 1

PART NO.: D-MD-711881-0-0

DATE: 10/27/72

BY: [Signature]

QTY: 1

PART NO.: E-AD-704355-0-0

DATE: 10/27/72

BY: [Signature]

4

3

2

1

REV. C  
SIZE K ML  
CODE MF20-0-WL  
NUMBER

THIS DRAWING AND SPECIFICATIONS, HEREIN, ARE THE PROPERTY OF DIGITAL EQUIPMENT CORPORATION AND SHALL NOT BE REPRODUCED OR COPIED OR USED IN WHOLE OR IN PART AS THE BASIS FOR THE MANUFACTURE OR SALE OF ITEMS WITHOUT WRITTEN PERMISSION

COPYRIGHT © 1978 DIGITAL EQUIPMENT CORPORATION

B

B

A

A

DESCRIPTION	DWG./PART NO.	ITEM NO.
UNLESS OTHERWISE SPECIFIED DIMENSIONS ARE IN INCHES		
ANGLES ± 0° 30'	CLASS OF ACCURACY (CHECK ONE)	NOMINAL DIMENSION RANGE INCHES
SURFACE QUALITY IN MICROINCHES	MEDIUM <input checked="" type="checkbox"/>	OVER 0 TO 12 ±.004 ±.008 ±.012 ±.016 ±.024 ±.04
	PREFERRED <input type="checkbox"/>	OVER 12 TO 40 OVER 40 TO 80.0 ±.012 ±.016 ±.025 ±.04 ±.063 ±.01

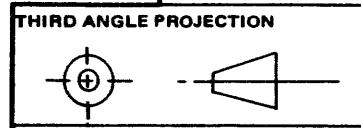

THIRD ANGLE PROJECTION

REMOVE BURRS AND BREAK SHARP CORNERS

DO NOT SCALE DWG

MATERIAL  $\text{---+---}$

FINISH  $\text{---+---}$

DRN *[Signature]* 7-27-78  
 CHK'D *[Signature]* 7-27-78  
 ENG. *[Signature]* 7-27-78  
 PROJ. ENG. *[Signature]* 7-27-78  
 PROD. *[Signature]* 7-27-78

FIRST USED ON  
 MF20 digital

TITLE  
 MF20  
 WIRE LIST

E-AD-7014358-0-0

SIZE	CODE	NUMBER	REV.
K ML		MF20-0-WL	C

SHEET 1 OF 1

REV.	CHANGE NO.