





FIND NO.	DRAWING NO.	DESCRIPTION	TYPE	FIND NO.	DRAWING NO.	DESCRIPTION	TYPE
1	B-DD-RTP2Ø-Ø-Ø	RTP2Ø DRAWING DIRECTORY	E/M	6	B-DD-RP2Ø-H-Ø	RP2Ø-H DRAWING DIRECTORY	E/M
	K-PL-RTP2Ø-Ø-DBP	RTP2Ø DISK DRIVE SYSTEMS (PL)	E/M				
	B-PL-RTP2Ø-Ø-Ø	RTP2Ø SHIP LIST	E/M				
2	B-DD-RH2Ø-Ø-Ø	RH2Ø DRAWING DIRECTORY	E/M				
3	B-DD-DX2Ø-Ø-Ø	DX2Ø DRAWING DIRECTORY	E/M				
4	B-DD-RP2Ø-A-Ø	RP2Ø-A DRAWING DIRECTORY	E/M				
5	B-DD-RP2Ø-D-Ø	RP2Ø-D DRAWING DIRECTORY	E/M				

TYPE: E ELECTRICAL  
M MECHANICAL  
E/M ELECTRO/MECHANICAL



TITLE  
RTP2Ø DRAWING DIRECTORY

SHEET 2 OF 3

SIZE CODE  
**B DD**

NUMBER  
RTP2Ø-Ø-Ø

REV  
A

"THIS DRAWING AND SPECIFICATIONS, HEREIN, ARE THE PROPERTY OF DIGITAL EQUIPMENT CORPORATION AND SHALL NOT BE REPRODUCED OR COPIED OR USED IN WHOLE OR IN PART AS THE BASIS FOR THE MANUFACTURE OR SALE OF ITEMS WITHOUT WRITTEN PERMISSION. 1980  
COPYRIGHT © DIGITAL EQUIPMENT CORPORATION"

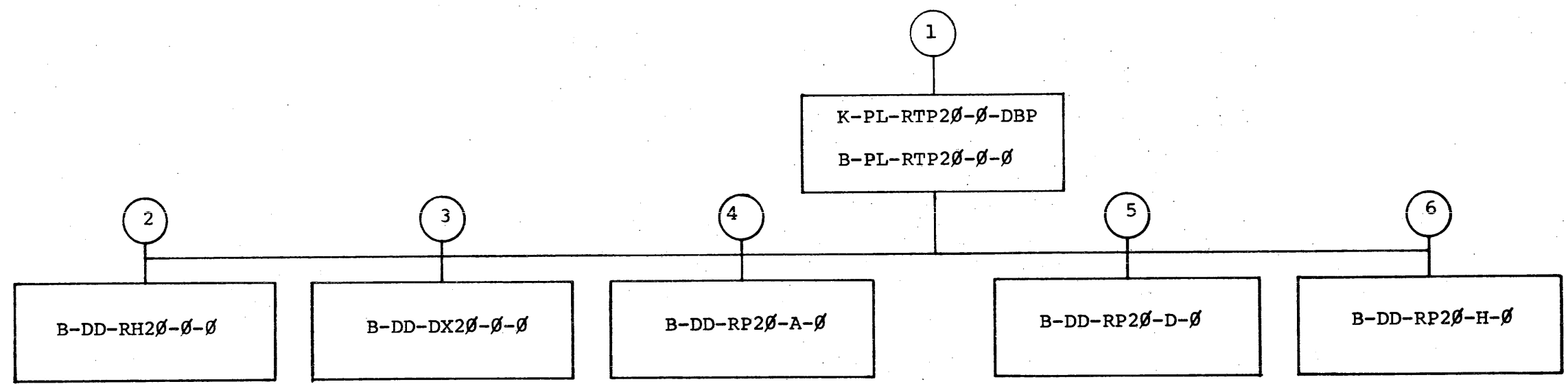

LINE ITEM	DOCUMENT NUMBER	PART NUMBER	DESCRIPTION	QUANTITY PER VARIATION													
				EA	EB	EC	ED	EE	EF	EH	EJ	FA	FB	FC	FD		
1	1	A=PL=RH20=0=0	ORH20=00	MASS BUS CONTROLLER	1	1	1	1	1	1	1	1	1	1	1	1	1
2	2	E=UA=DX20=0=0	ODX20=BE	DX20=BC WITH BLUE COSMETIC COVER	1	0	1	0	0	0	0	0	0	0	0	0	0
3	3	B=DD=RP20=H=0	ORP20=HA	SINGLE ACCESS CONTROL FOR RP20=A	1	0	0	0	1	0	0	0	0	1	0	0	0
4	4	K=PL=RP20=A=DBP	ORP20=AA	SINGLE PORT MASTER DISK,3 PHASE	1	0	0	0	1	0	0	0	0	0	0	0	0
5	5	E=UA=DX20=0=0	ODX20=BF	DX20=BD WITH BLUE COSMETIC COVER	0	1	0	1	0	0	0	0	0	0	0	0	0
6	6	B=DD=RP20=H=0	ORP20=HB	SINGLE ACCESS CONTROL FOR RP20=A	0	1	0	0	0	1	0	0	0	0	1	0	0
7	7	K=PL=RP20=A=DBP	ORP20=AB	SINGLE PORT MASTER DISK,3 PHASE	0	1	0	0	0	1	0	0	0	0	0	0	0
8	8	B=DD=RP20=D=0	ORP20=DA	DUAL ACCESS CONTROL UPGRADE KIT	0	0	1	1	0	0	1	1	1	0	0	1	1
9	9	E=UA=DX20=0=0	ODX20=BA	DISK MICROCODE INTFCE TO IBM MUX	0	0	0	0	1	0	1	0	0	0	0	0	0
10	10	E=UA=DX20=0=0	ODX20=BB	DISK MICROCODE INTFCE TO IBM MUX	0	0	0	0	0	1	0	1	0	0	0	0	0
11	11	E=UA=DX20=0=0	ODX20=BC	DISK MICROCODE INTFCE TO IBM MUX	0	0	0	0	0	0	0	0	1	0	1	0	0
12	12	K=PL=RP20=A=DBP	ORP20=AE	SINGLE PORT MASTER DISK,3 PHASE	0	0	0	0	0	0	0	0	0	1	0	0	0
13	13	E=UA=DX20=0=0	ODX20=BD	DISK MICROCODE INTFCE TO IBM MUX	0	0	0	0	0	0	0	0	0	0	1	0	1
14	14	K=PL=RP20=A=DBP	ORP20=AF	SINGLE PORT MASTER DISK,3 PHASE	0	0	0	0	0	0	0	0	0	0	1	0	0

REVISION HISTORY			BASIC PART NO: RTP20		DRN: J, DONAHER		DATE: 30-OCT-80		D I G I T A L			
ENG	ECO NUMBER	REV	SECTION A OF A		CHK'D: J, HUSON		DATE: 19-NOV-80		TITLE PARTS LIST			
	INITIAL	A	SECTION, VARIATION INDEX		DES, ENG, B MCQUAIN		DATE: 15-DEC-80		DOCUMENT NUMBER			
			(A) EA, EB, EC, ED, EE, EF, EH, EJ, FA, FB, FC, FD		RESP, ENG, B MCQUAIN <td colspan="2">DATE: 15-DEC-80 <td colspan="4">SIZE CODE NUMBER REV</td> </td>		DATE: 15-DEC-80 <td colspan="4">SIZE CODE NUMBER REV</td>		SIZE CODE NUMBER REV			
			(B)		MFG, ENG, T BARRETT <td colspan="2">DATE: 15-DEC-80 <td colspan="4">K PL RTP20=0=DBP A</td> </td>		DATE: 15-DEC-80 <td colspan="4">K PL RTP20=0=DBP A</td>		K PL RTP20=0=DBP A			
			(C)		ASSEMBLY NUMBER: B=AR-RTP20=0=0 <td colspan="2">TOP DOCUMENT NUMBER: B=DD-RTP20=0=0 <td colspan="4">FILE NAME: Z1705A, PLS EDIT # 10</td> </td>		TOP DOCUMENT NUMBER: B=DD-RTP20=0=0 <td colspan="4">FILE NAME: Z1705A, PLS EDIT # 10</td>		FILE NAME: Z1705A, PLS EDIT # 10			
			(D)									
			(E)									
			(F)									

"THIS DRAWING AND SPECIFICATIONS HEREIN, ARE THE PROPERTY OF DIGITAL EQUIPMENT CORPORATION AND SHALL NOT BE REPRODUCED OR COPIED OR USED IN WHOLE OR IN PART AS THE BASIS FOR THE MANUFACTURE OR SALE OF ITEMS WITHOUT WRITTEN PERMISSION, COPYRIGHT (C) 1980, DIGITAL EQUIPMENT CORPORATION "

# DIGITAL EQUIPMENT CORPORATION PARTS LIST

MADE BY <i>Joe Donaher</i>	CHECKED <i>J. Huson</i>	SECTION
DATE <i>30-OCT-80</i>	DATE <i>2 Dec 80</i>	
ENG <i>B.M. Quinn</i>	PROD <i>SE Bennett</i>	ISSUED SECTION
DATE <i>15 DEC 80</i>	DATE <i>15 DEC 80</i>	

## QUANTITY / VARIATION

NOTES:

ITEM NO.	DRAWING NO.	PART NO.	DESCRIPTION	QUANTITY / VARIATION												REF DESIGNATION	
				RTP20-EA	RTP20-EB	RTP20-EC	RTP20-ED	RTP20-EE	RTP20-EF	RTP20-EH	RTP20-EJ	RTP20-FA	RTP20-FB	RTP20-FC	RTP20-FD		
1.	K-PL-RTP20-0-DBP	RTP20-EA	MASTER SUBSYSTEM 60HZ (1091)	1	-	-	-	-	-	-	-	-	-	-	-	-	-
2.	K-PL-RTP20-0-DBP	RTP20-EB	MASTER SUBSYSTEM 50HZ (1091)	-	1	-	-	-	-	-	-	-	-	-	-	-	-
3.	K-PL-RTP20-0-DBP	RTP20-EC	DUAL CHANNEL OPTION 60HZ (RTP20-EA)	-	-	1	-	-	-	-	-	-	-	-	-	-	-
4.	K-PL-RTP20-0-DBP	RTP20-ED	DUAL CHANNEL OPTION 50HZ (RTP20-EB)	-	-	-	1	-	-	-	-	-	-	-	-	-	-
5.	K-PL-RTP20-0-DBP	RTP20-EE	MASTER SUBSYSTEM 60HZ (1090)	-	-	-	-	1	-	-	-	-	-	-	-	-	-
6.	K-PL-RTP20-0-DBP	RTP20-EF	MASTER SUBSYSTEM 50HZ (1090)	-	-	-	-	-	1	-	-	-	-	-	-	-	-
7.	K-PL-RTP20-0-DBP	RTP20-EH	DUAL CHANNEL OPTION 60HZ (RTP20-EE)	-	-	-	-	-	-	1	-	-	-	-	-	-	-
8.	K-PL-RTP20-0-DBP	RTP20-EJ	DUAL CHANNEL OPTION 50HZ (RTP20-EF)	-	-	-	-	-	-	-	1	-	-	-	-	-	-
9.	K-PL-RTP20-0-DBP	RTP20-FA	MASTER SUBSYSTEM 60HZ (2040/60)	-	-	-	-	-	-	-	-	1	-	-	-	-	-
10.	K-PL-RTP20-0-DBP	RTP20-FB	MASTER SUBSYSTEM 50HZ (2040/60)	-	-	-	-	-	-	-	-	-	1	-	-	-	-
11.	K-PL-RTP20-0-DBP	RTP20-FZ	DUAL CHANNEL OPTION 60HZ (RTP20-FA)	-	-	-	-	-	-	-	-	-	-	1	-	-	-
12.	K-PL-RTP20-0-DBP	RTP20-FD	DUAL CHANNEL OPTION 50HZ (RTP20-FB)	-	-	-	-	-	-	-	-	-	-	-	-	1	-

E.C.O. NO.

<p>"THIS DRAWING AND SPECIFICATIONS, HEREIN, ARE THE PROPERTY OF DIGITAL EQUIPMENT CORPORATION AND SHALL NOT BE REPRODUCED OR COPIED OR USED IN WHOLE OR IN PART AS THE BASIS FOR THE MANUFACTURE OR SALE OF ITEMS WITHOUT WRITTEN PERMISSION. COPYRIGHT © 1980 DIGITAL EQUIPMENT CORPORATION"</p>	<p>TITLE <b>RTP20 SHIP LIST</b></p>	<p>ASSY NO.</p>	<p>SIZE <b>B</b></p>	<p>CODE <b>PL</b></p>	<p>NUMBER <b>RTP20-0-0</b></p>	<p>REV. <b>A</b></p>
		<p>SHEET <b>1</b> OF <b>1</b></p>	<p>INSERTION PARTS LIST DATA BASE REV</p>			

THIS DRAWING AND SPECIFICATIONS HEREIN ARE THE PROPERTY OF ANALOG EQUIPMENT CORPORATION AND SHALL NOT BE REPRODUCED OR COPIED OR USED IN WHOLE OR IN PART AS THE BASIS FOR THE MANUFACTURE OR SALE OF ITEMS WITHOUT WRITTEN PERMISSION.  
 COPYRIGHT © 1960 ANALOG EQUIPMENT CORPORATION

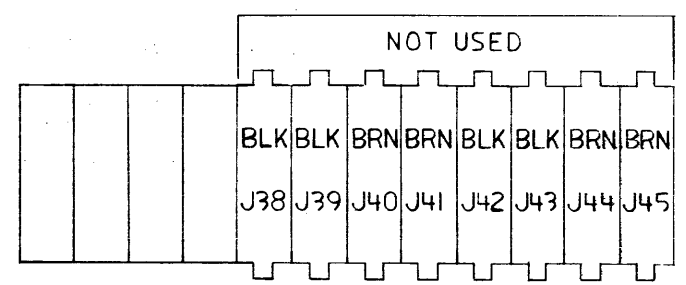
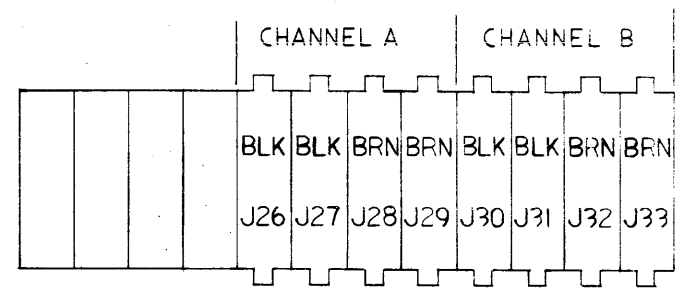
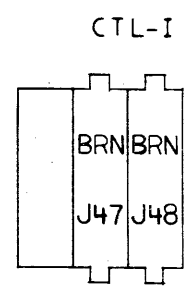
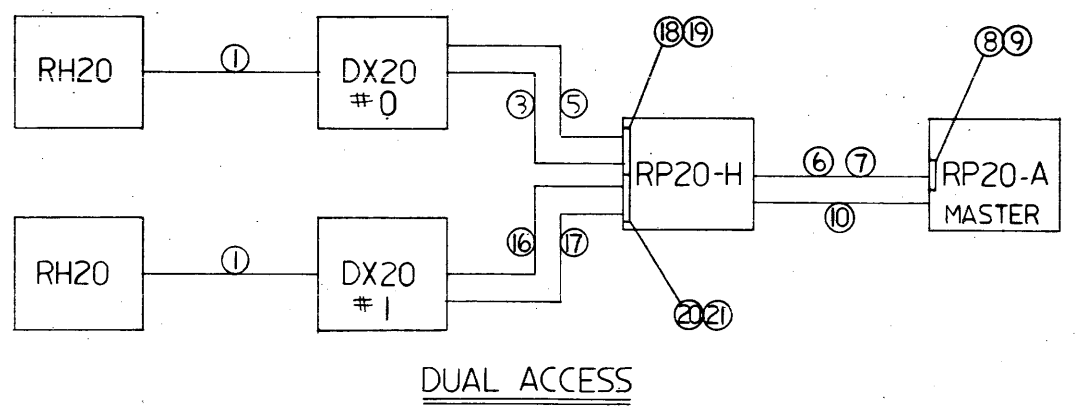
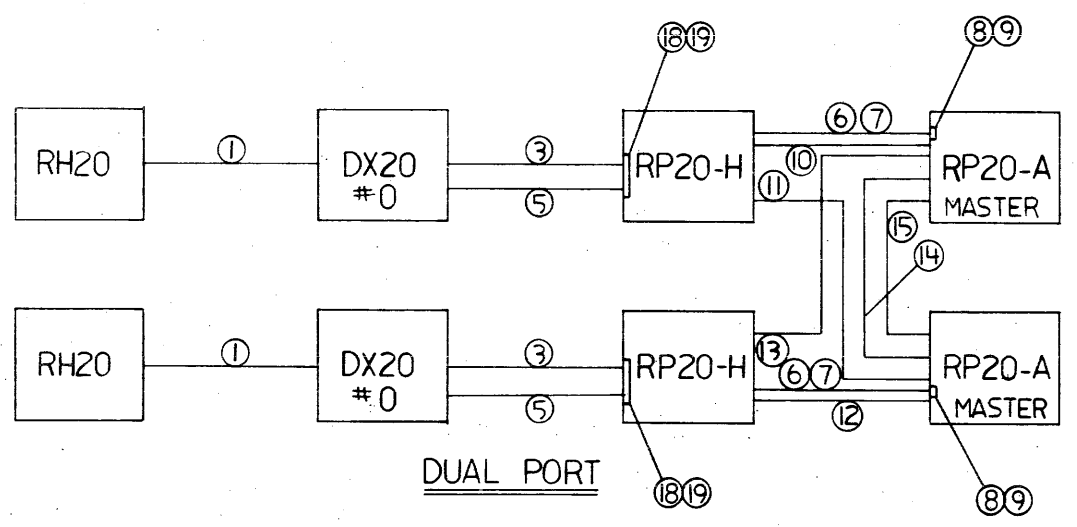
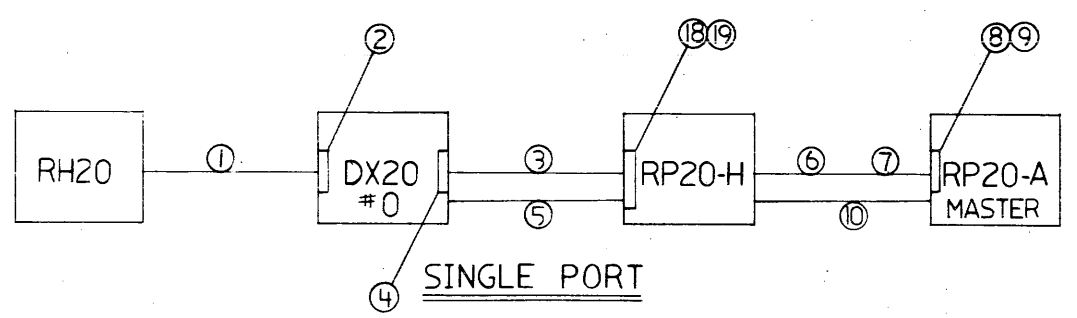

RP20-H CHANNEL & CONTROL CABLE CONNECTORS (INSERTION VIEW)

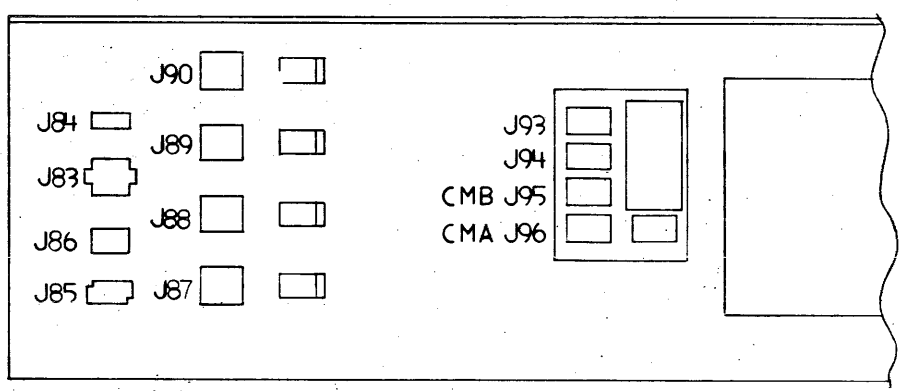

RP20-H EPO CONNECTIONS (AC POWER SUPPLY)

REV.	
CHK	
CHANGE NO.	

DESCRIPTION		DWG./PART NO.		ITEM NO.
UNLESS OTHERWISE SPECIFIED DIMENSIONS ARE IN INCHES				
ANGLES 30° 30'	CLASS OF ACCURACY	NOMINAL DIMENSION RANGE INCHES		
	(CHECK ONE)	OVER 0 TO 0.25	OVER 0.25 TO 1.2	OVER 1.2 TO 4.0
SURFACE QUALITY IN	MEDIUM	±.004	±.008	±.012
QUANTITY & VARIATION	PREFERRED	±.012	±.018	±.025
THIRD ANGLE PROJECTION	DRN. J. Huson 3/1/60	FIRST USED ON RP20 digital		
REMOVE BURRS AND BREAK SHARP CORNERS	CHK'D J. Huson 2/2/60	TITLE		
DO NOT SCALE DWG	ENG. J. Huson 15/2/60	RTP20 SYSTEM CABLING		
MATERIAL	PROD. J. Huson 15/2/60	SIZE	CODE	NUMBER
FINISH	PROJ. ENG. J. Huson 15/2/60	NONE	D I C	RTP20-0-0
	PROD. J. Huson 15/2/60	SCALE	NONE	REV. A
		SHEET	OF 2	DIST.



"THIS DRAWING AND SPECIFICATIONS, HEREIN, ARE THE PROPERTY OF DIGITAL EQUIPMENT CORPORATION AND SHALL NOT BE REPRODUCED OR COPIED OR USED IN WHOLE OR IN PART AS THE BASIS FOR THE MANUFACTURE OR SALE OF ITEMS WITHOUT WRITTEN PERMISSION.

COPYRIGHT © 80 DIGITAL EQUIPMENT CORPORATION

# ARRANGEMENT

## GUIDELINES

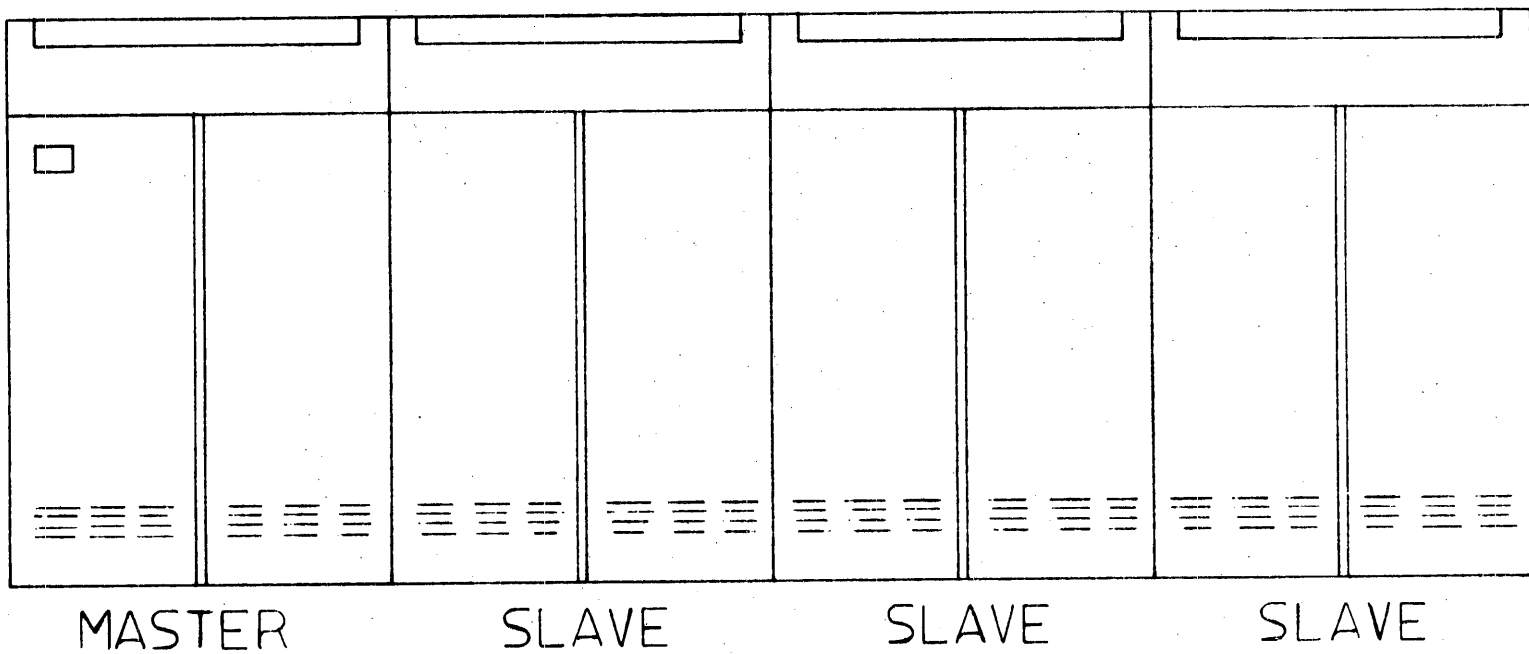

1. ALL SLAVES MUST BE TO THE RIGHT OF MASTER AT ALL TIMES.
2. THERE IS TO BE NO SEPARATION BETWEEN DRIVES AT ANY TIME.
3. THREE SLAVE DRIVES ARE THE MAXIMUM NUMBER OF DRIVES PER MASTER.

### REVISIONS

CHK	CHANGE NO.	REV.

TITLE RTP20 SUBSYSTEM ARRANGEMENT		SIZE B	CODE AR	NUMBER RTP20-0-C				REV. A
SCALE NONE	SHEET   OF	DIST.						





LINE ITEM	DOCUMENT NUMBER	PART NUMBER	DESCRIPTION	QUANTITY PER VARIATION							
				AA	AB	AC	AD	AE	AF	AH	AJ
1	D-AD-7018183-0-0	7018183-00	RP20-A SINGLE PORT MASTER 60HZ	1	0	0	0	1	0	0	0
2	D-AD-7018183-0-0	7018183-01	RP20-A SINGLE PORT MASTER 50HZ	0	1	0	0	0	1	0	0
3	D-AD-7018183-0-0	7018183-02	RP20-A SINGLE PORT SLAVE 60HZ	0	0	1	0	0	0	1	0
4	D-AD-7018183-0-0	7018183-03	RP20-A SINGLE PORT SLAVE 50HZ	0	0	0	1	0	0	0	1

REVISION HISTORY			BASIC PART NO: ORP20		DRN: JOE DONAHER		DATE: 24-OCT-80		DIGITAL			
ENG	ECO NUMBER	REV	SECTION A OF A	CHK'D:	J, HUSON	DATE:	19-NOV-80	TITLE		PARTS LIST		
---	INITIAL	A	SECTION, VARIATION INDEX [A] AA, AB, AC, AD, AE, AF, AH, AJ	CHK'D:	J, HUSON	DATE:	19-NOV-80	RP20-A DISK DRIVE				
			[B]	DES, ENG,:	B MCQUAIN	DATE:	15-DEC-80					
			[C]	RESP, ENG,:	B MCQUAIN	DATE:	15-DEC-80	DOCUMENT NUMBER				
			[D]					SIZE:	CODE:	NUMBER	REV	
			[E]	MFG, ENG,:	T BARRETT	DATE:	15-DEC-80	K	PL	RP20-A-DBP	A	
			[F]	ASSEMBLY NUMBER:		TOP DOCUMENT NUMBER:		FILE NAME:	EDIT #			
				K-PL-RP20-A-DBP		B-DD-RP20-A-0		Z1703A, PLS	12			

\*THIS DRAWING AND SPECIFICATIONS HEREIN, ARE THE PROPERTY OF DIGITAL EQUIPMENT CORPORATION AND SHALL NOT BE REPRODUCED  
 OR COPIED OR USED IN WHOLE OR IN PART AS THE BASIS FOR THE MANUFACTURE OR SALE OF ITEMS WITHOUT WRITTEN PERMISSION.  
 COPYRIGHT (C) 1980, DIGITAL EQUIPMENT CORPORATION \*

# DIGITAL EQUIPMENT CORPORATION PARTS LIST

QUANTITY / VARIATION

NOTES:

MADE BY <i>Joe Donaher</i>	CHECKED <i>J. Huson</i>	SECTION
DATE <i>28 OCT 80</i>	DATE <i>2 Dec 80</i>	
ENG <i>B. McCain</i>	PROD <i>S. E. Bennett</i>	ISSUED SECTION
DATE <i>15 DEC 80</i>	DATE <i>15 Dec 80</i>	

RP20-AA	RP20-AB	RP20-AC	RP20-AD	RP20-AE	RP20-AF	RP20-AH	RP20-AJ										
---------	---------	---------	---------	---------	---------	---------	---------	--	--	--	--	--	--	--	--	--	--

ITEM NO.	DRAWING NO.	PART NO.	DESCRIPTION	RP20-AA	RP20-AB	RP20-AC	RP20-AD	RP20-AE	RP20-AF	RP20-AH	RP20-AJ							REF DESIGNATION
1	ER-83650-RM-001		8350/8650 MRM	1	1	-	-	1	1	-	-							
2	ER-3650M-RM-001		8650 MRM	1	1	-	-	1	1	-	-							
3	K-PL-RP20-A-DBP	RP20-AA	MASTER DRIVE 60HZ TOPS 10	1	-	-	-	-	-	-	-							
4	K-PL-RP20-A-DBP	RP20-AB	MASTER DRIVE 50HZ TOPS 10	-	1	-	-	-	-	-	-							
5	K-PL-RP20-A-DBP	RP20-AC	SLAVE DRIVE 60HZ TOPS 10	-	-	1	-	-	-	-	-							
6	K-PL-RP20-A-DBP	RP20-AD	SLAVE DRIVE 50HZ TOPS 10	-	-	-	1	-	-	-	-							
7	K-PL-RP20-A-DBP	RP20-AE	MASTER DRIVE 60HZ TOPS 20	-	-	-	-	1	-	-	-							
8	K-PL-RP20-A-DBP	RP20-AF	MASTER DRIVE 50HZ TOPS 20	-	-	-	-	-	1	-	-							
9	K-PL-RP20-A-DBP	RP20-AH	SLAVE DRIVE 60HZ TOPS 20	-	-	-	-	-	-	1	-							
10	K-PL-RP20-A-DBP	RP20-AJ	SLAVE DRIVE 50HZ TOPS 20	-	-	-	-	-	-	-	1							

E.C.O. NO. \_\_\_\_\_

"THIS DRAWING AND SPECIFICATIONS, HEREIN, ARE THE PROPERTY OF DIGITAL EQUIPMENT CORPORATION AND SHALL NOT BE REPRODUCED OR COPIED OR USED IN WHOLE OR IN PART AS THE BASIS FOR THE MANUFACTURE OR SALE OF ITEMS WITHOUT WRITTEN PERMISSION. COPYRIGHT © 1980 DIGITAL EQUIPMENT CORPORATION"	TITLE <p style="text-align: center;">RP20-A SHIP LIST</p>	ASSY NO.	SIZE <p style="text-align: center;"><b>B</b></p>	CODE <p style="text-align: center;"><b>PL</b></p>	NUMBER <p style="text-align: center;">RP20-A-0</p>	REV. <p style="text-align: center;">A</p>
SHEET 1 OF 1			INSERTION PARTS LIST DATA BASE REV			



THIS DRAWING AND SPECIFICATIONS HEREIN ARE THE PROPERTY OF DIGITAL EQUIPMENT CORPORATION AND SHALL NOT BE REPRODUCED OR COPIED OR USED IN WHOLE OR IN PART AS THE BASIS FOR THE MANUFACTURE OR SALE OF ITEMS WITHOUT WRITTEN PERMISSION.  
 COPYRIGHT © 1980, DIGITAL EQUIPMENT CORPORATION

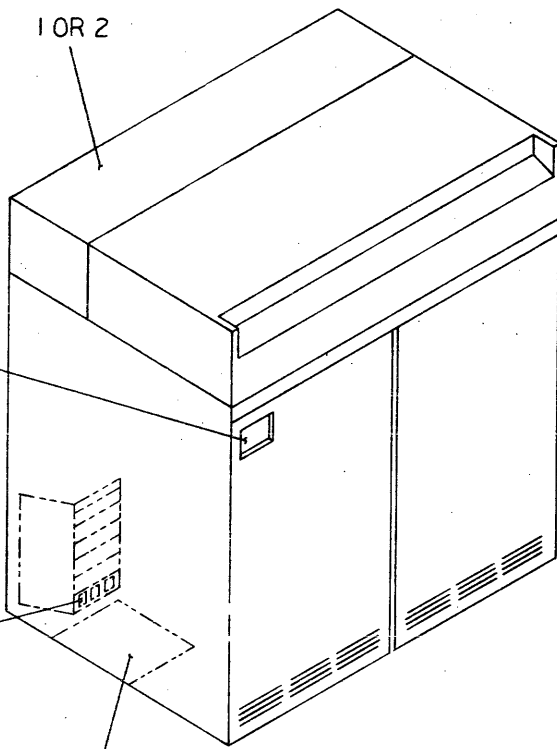

MASTER DRIVE  
 RP20-AA,AB,AE,AF  
 REF

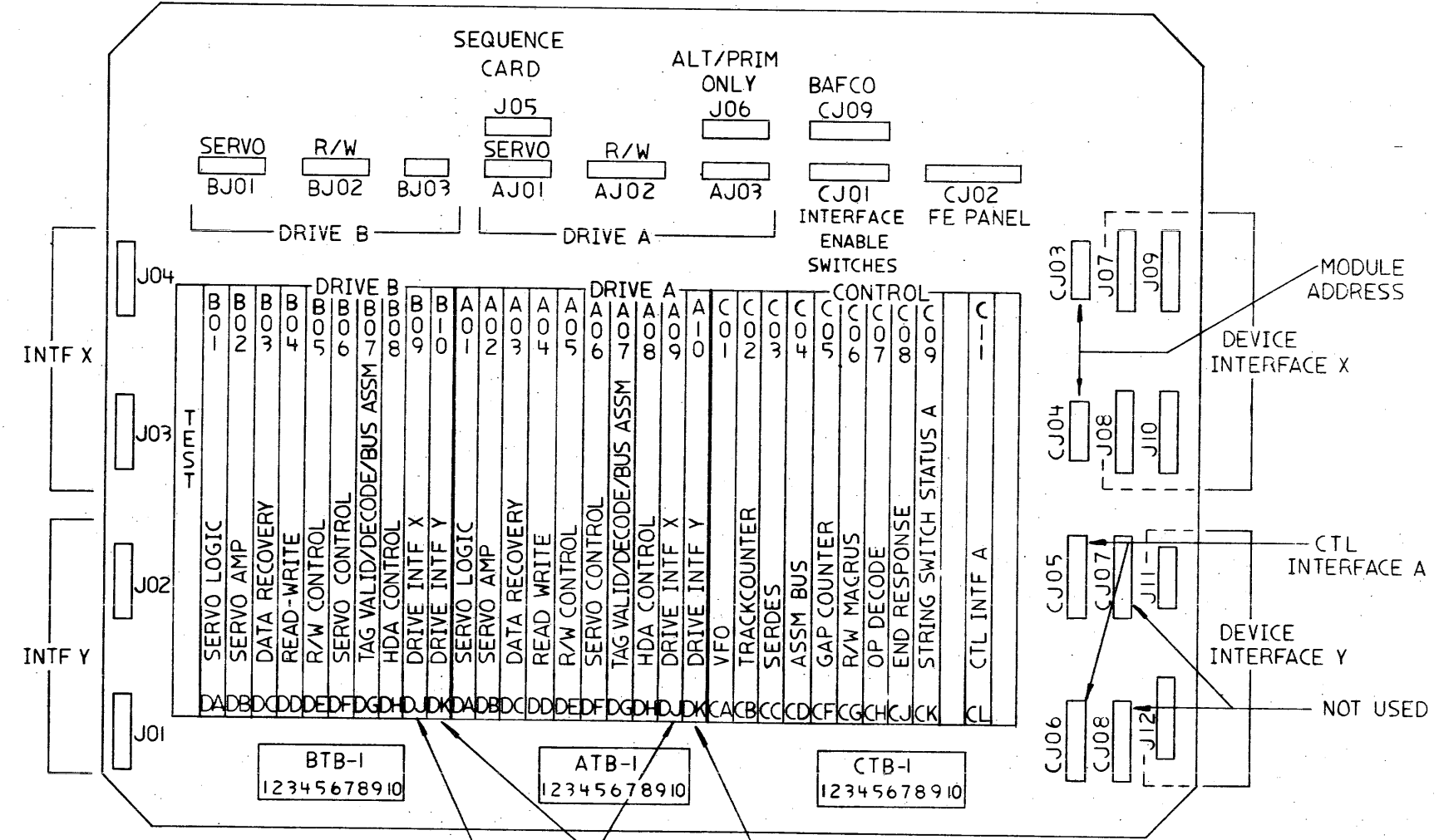

SINGLE PORT  
 DUAL PORT  
 REMOVE THESE MODULES FOR MASTER DRIVES RP20-AA,AB,AE,AF

CAUTION: OFF SHEETS PARTS LIST EXISTS SEE K-PL-7018183-0-DBP

REV.	
CHANGE NO.	
CHK	

QUANTITY & VARIATION	DESCRIPTION	DWG./PART NO.	ITEM NO.
	UNLESS OTHERWISE SPECIFIED DIMENSIONS ARE IN INCHES		
	ANGLES 90° 30'	CLASS OF ACCURACY	NOMINAL DIMENSION RANGE INCHES
			OVER 0 TO 12.0
			OVER 12.0 TO 40.0
			OVER 40.0 TO 80.0
			OVER 80.0 TO 120.0
			OVER 120.0 TO 160.0
			OVER 160.0 TO 200.0
			OVER 200.0 TO 250.0
			OVER 250.0 TO 300.0
			OVER 300.0 TO 350.0
			OVER 350.0 TO 400.0
			OVER 400.0 TO 450.0
			OVER 450.0 TO 500.0
			OVER 500.0 TO 550.0
			OVER 550.0 TO 600.0
			OVER 600.0 TO 650.0
			OVER 650.0 TO 700.0
			OVER 700.0 TO 750.0
			OVER 750.0 TO 800.0
			OVER 800.0 TO 850.0
			OVER 850.0 TO 900.0
			OVER 900.0 TO 950.0
			OVER 950.0 TO 1000.0
			OVER 1000.0 TO 1050.0
			OVER 1050.0 TO 1100.0
			OVER 1100.0 TO 1150.0
			OVER 1150.0 TO 1200.0
			OVER 1200.0 TO 1250.0
			OVER 1250.0 TO 1300.0
			OVER 1300.0 TO 1350.0
			OVER 1350.0 TO 1400.0
			OVER 1400.0 TO 1450.0
			OVER 1450.0 TO 1500.0
			OVER 1500.0 TO 1550.0
			OVER 1550.0 TO 1600.0
			OVER 1600.0 TO 1650.0
			OVER 1650.0 TO 1700.0
			OVER 1700.0 TO 1750.0
			OVER 1750.0 TO 1800.0
			OVER 1800.0 TO 1850.0
			OVER 1850.0 TO 1900.0
			OVER 1900.0 TO 1950.0
			OVER 1950.0 TO 2000.0
			OVER 2000.0 TO 2050.0
			OVER 2050.0 TO 2100.0
			OVER 2100.0 TO 2150.0
			OVER 2150.0 TO 2200.0
			OVER 2200.0 TO 2250.0
			OVER 2250.0 TO 2300.0
			OVER 2300.0 TO 2350.0
			OVER 2350.0 TO 2400.0
			OVER 2400.0 TO 2450.0
			OVER 2450.0 TO 2500.0
			OVER 2500.0 TO 2550.0
			OVER 2550.0 TO 2600.0
			OVER 2600.0 TO 2650.0
			OVER 2650.0 TO 2700.0
			OVER 2700.0 TO 2750.0
			OVER 2750.0 TO 2800.0
			OVER 2800.0 TO 2850.0
			OVER 2850.0 TO 2900.0
			OVER 2900.0 TO 2950.0
			OVER 2950.0 TO 3000.0
			OVER 3000.0 TO 3050.0
			OVER 3050.0 TO 3100.0
			OVER 3100.0 TO 3150.0
			OVER 3150.0 TO 3200.0
			OVER 3200.0 TO 3250.0
			OVER 3250.0 TO 3300.0
			OVER 3300.0 TO 3350.0
			OVER 3350.0 TO 3400.0
			OVER 3400.0 TO 3450.0
			OVER 3450.0 TO 3500.0
			OVER 3500.0 TO 3550.0
			OVER 3550.0 TO 3600.0
			OVER 3600.0 TO 3650.0
			OVER 3650.0 TO 3700.0
			OVER 3700.0 TO 3750.0
			OVER 3750.0 TO 3800.0
			OVER 3800.0 TO 3850.0
			OVER 3850.0 TO 3900.0
			OVER 3900.0 TO 3950.0
			OVER 3950.0 TO 4000.0
			OVER 4000.0 TO 4050.0
			OVER 4050.0 TO 4100.0
			OVER 4100.0 TO 4150.0
			OVER 4150.0 TO 4200.0
			OVER 4200.0 TO 4250.0
			OVER 4250.0 TO 4300.0
			OVER 4300.0 TO 4350.0
			OVER 4350.0 TO 4400.0
			OVER 4400.0 TO 4450.0
			OVER 4450.0 TO 4500.0
			OVER 4500.0 TO 4550.0
			OVER 4550.0 TO 4600.0
			OVER 4600.0 TO 4650.0
			OVER 4650.0 TO 4700.0
			OVER 4700.0 TO 4750.0
			OVER 4750.0 TO 4800.0
			OVER 4800.0 TO 4850.0
			OVER 4850.0 TO 4900.0
			OVER 4900.0 TO 4950.0
			OVER 4950.0 TO 5000.0
			OVER 5000.0 TO 5050.0
			OVER 5050.0 TO 5100.0
			OVER 5100.0 TO 5150.0
			OVER 5150.0 TO 5200.0
			OVER 5200.0 TO 5250.0
			OVER 5250.0 TO 5300.0
			OVER 5300.0 TO 5350.0
			OVER 5350.0 TO 5400.0
			OVER 5400.0 TO 5450.0
			OVER 5450.0 TO 5500.0
			OVER 5500.0 TO 5550.0
			OVER 5550.0 TO 5600.0
			OVER 5600.0 TO 5650.0
			OVER 5650.0 TO 5700.0
			OVER 5700.0 TO 5750.0
			OVER 5750.0 TO 5800.0
			OVER 5800.0 TO 5850.0
			OVER 5850.0 TO 5900.0
			OVER 5900.0 TO 5950.0
			OVER 5950.0 TO 6000.0
			OVER 6000.0 TO 6050.0
			OVER 6050.0 TO 6100.0
			OVER 6100.0 TO 6150.0
			OVER 6150.0 TO 6200.0
			OVER 6200.0 TO 6250.0
			OVER 6250.0 TO 6300.0
			OVER 6300.0 TO 6350.0
			OVER 6350.0 TO 6400.0
			OVER 6400.0 TO 6450.0
			OVER 6450.0 TO 6500.0
			OVER 6500.0 TO 6550.0
			OVER 6550.0 TO 6600.0
			OVER 6600.0 TO 6650.0
			OVER 6650.0 TO 6700.0
			OVER 6700.0 TO 6750.0
			OVER 6750.0 TO 6800.0
			OVER 6800.0 TO 6850.0
			OVER 6850.0 TO 6900.0
			OVER 6900.0 TO 6950.0
			OVER 6950.0 TO 7000.0
			OVER 7000.0 TO 7050.0
			OVER 7050.0 TO 7100.0
			OVER 7100.0 TO 7150.0
			OVER 7150.0 TO 7200.0
			OVER 7200.0 TO 7250.0
			OVER 7250.0 TO 7300.0
			OVER 7300.0 TO 7350.0
			OVER 7350.0 TO 7400.0
			OVER 7400.0 TO 7450.0
			OVER 7450.0 TO 7500.0
			OVER 7500.0 TO 7550.0
			OVER 7550.0 TO 7600.0
			OVER 7600.0 TO 7650.0
			OVER 7650.0 TO 7700.0
			OVER 7700.0 TO 7750.0
			OVER 7750.0 TO 7800.0
			OVER 7800.0 TO 7850.0
			OVER 7850.0 TO 7900.0
			OVER 7900.0 TO 7950.0
			OVER 7950.0 TO 8000.0
			OVER 8000.0 TO 8050.0
			OVER 8050.0 TO 8100.0
			OVER 8100.0 TO 8150.0
			OVER 8150.0 TO 8200.0
			OVER 8200.0 TO 8250.0
			OVER 8250.0 TO 8300.0
			OVER 8300.0 TO 8350.0
			OVER 8350.0 TO 8400.0
			OVER 8400.0 TO 8450.0
			OVER 8450.0 TO 8500.0
			OVER 8500.0 TO 8550.0
			OVER 8550.0 TO 8600.0
			OVER 8600.0 TO 8650.0
			OVER 8650.0 TO 8700.0
			OVER 8700.0 TO 8750.0
			OVER 8750.0 TO 8800.0
			OVER 8800.0 TO 8850.0
			OVER 8850.0 TO 8900.0
			OVER 8900.0 TO 8950.0
			OVER 8950.0 TO 9000.0
			OVER 9000.0 TO 9050.0
			OVER 9050.0 TO 9100.0
			OVER 9100.0 TO 9150.0
			OVER 9150.0 TO 9200.0
			OVER 9200.0 TO 9250.0
			OVER 9250.0 TO 9300.0
			OVER 9300.0 TO 9350.0
			OVER 9350.0 TO 9400.0
			OVER 9400.0 TO 9450.0
			OVER 9450.0 TO 9500.0
			OVER 9500.0 TO 9550.0
			OVER 9550.0 TO 9600.0
			OVER 9600.0 TO 9650.0
			OVER 9650.0 TO 9700.0
			OVER 9700.0 TO 9750.0
			OVER 9750.0 TO 9800.0
			OVER 9800.0 TO 9850.0
			OVER 9850.0 TO 9900.0
			OVER 9900.0 TO 9950.0
			OVER 9950.0 TO 10000.0

THIRD ANGLE PROJECTION  
 REMOVE BURRS AND BREAK SHARP CORNERS  
 DO NOT SCALE DWG  
 MATERIAL  
 FINISH

DRN. J. Dineen  
 CHK'd J. Huson  
 ENG. B. C. C. 15 DEC 80  
 PROJ. ENG. M. C. 15 DEC 80  
 PROD. S. P. 15 DEC 80  
 FIRST USED ON RP20  
 TITLE RP20-A MASTER/SLAVE REWORK  
 B-DD-RP20-A-0  
 SCALE NONE  
 SHEET OF 2  
 DIST. D AD 7018183-0-0  
 REV. A

THIS DRAWING AND SPECIFICATIONS HEREBY ARE THE PROPERTY OF DIGITAL EQUIPMENT CORPORATION AND SHALL NOT BE REPRODUCED OR COPIED OR USED IN WHOLE OR IN PART AS THE BASIS FOR THE MANUFACTURE OR SALE OF ITEMS WITHOUT WRITTEN PERMISSION.  
 COPYRIGHT © 1980 DIGITAL EQUIPMENT CORPORATION

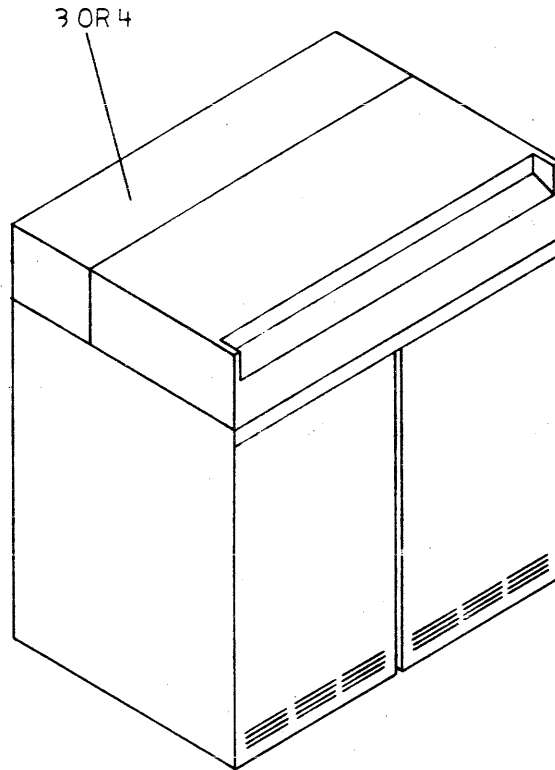

SLAVE DRIVE  
 RP20-AC,AD,AH,AJ  
 REF

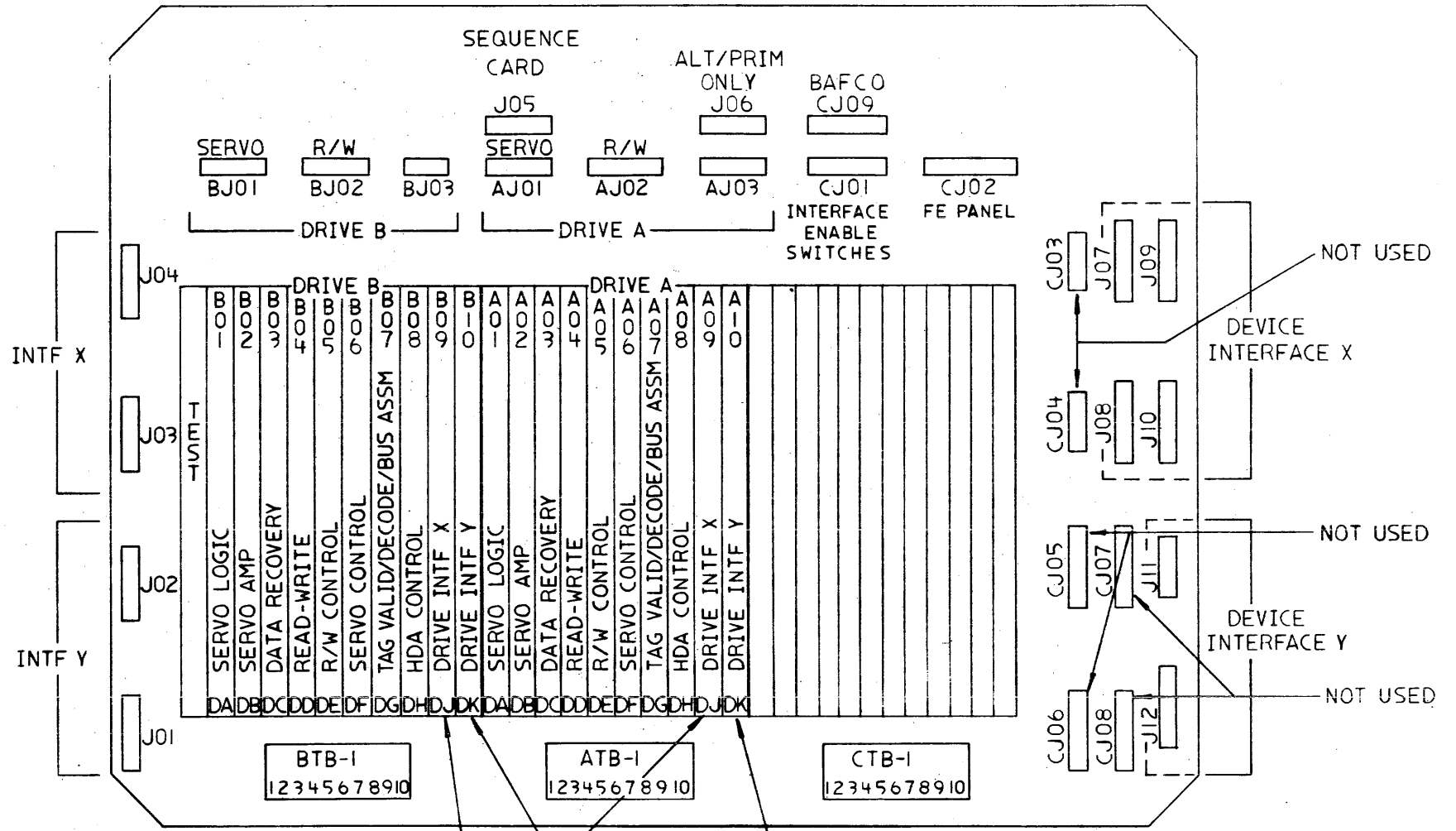

REMOVE THESE  
 MODULES FOR SLAVE DRIVES  
 RP20-AC,AD,AH,AJ

SINGLE PORT

DUAL PORT

REVISION HISTORY		
DATE	ECO NUMBER	REV.







This document contains confidential proprietary information of DEC. This information shall not be disclosed to persons outside the employ of DEC, except by DEC personnel so authorized by DEC, and only for use by such other persons in the design, production or manufacture of products for DEC. Copyright © Digital Equipment Corporation.

**DIGITAL EQUIPMENT CORPORATION**  
MAYNARD, MASSACHUSETTS

**ENGINEERING SPECIFICATION**

DATE 12 DEC 80

TITLE RP20 DUAL PORT INSTALLATION PROCEDURE

REVISIONS

REV	DESCRIPTION	CHG NO	ORIG	DATE	APPD BY	DATE

ENG <i>Bruno Deoni</i>	APPD <i>Bruno Deoni</i>	SIZE <b>A</b>	CODE SP	NUMBER RP20-C-2	REV <b>A</b>
------------------------	-------------------------	---------------	---------	-----------------	--------------

EN-1079A-16-R873-(392)  
DRA 107A

**ENGINEERING SPECIFICATION**



CONTINUATION SHEET

TITLE RP20 DUAL PORT INSTALLATION PROCEDURE

NOTE:

DCU "A" and String "A" will represent the low order addressed disk drives 0 through 7 and associated RP20-H controller.

DCU "B" and String "B" will represent the high order addressed disk drives 8 through F and associated RP20-H controller.

1. EQUIPMENT NEEDED

1. 30 gauge wire wrap gun
2. 30 gauge wire

2. INITIAL CHECKOUT

1. Obtain customer permission to install Dual Port Upgrade Kit.
2. Verify Control Unit microdiagnostics run on the DCU "A" and DCU "B" prior to installing upgrade kit.
3. Verify Functional/Inline microdiagnostics run on the ALL disk drives prior to installing dual port upgrade kit.
4. Correct all problems/failures before proceeding.

3. DCU ADDRESSING

1. Power down both RP20 subsystem by putting the ON/OFF switch to the "OFF" position on the DCU.
2. Remove the bottom logic door of both DCUs.
3. Remove the CI2 card (P/N 29-23734) from card location B13 of both DCUs.
4. Change the address switch setting of KA07 (DCU Address Switches) from 00 (hex) to X1 (hex) where X = any number 1 through F on both CI2 cards. The address must be the same for both CI2 cards.

NOTE:

This will be the new address of the DCU for dual port operation.

5. Reinstall the CI2 card in location B13 of both DCU's.

SIZE <b>A</b>	CODE SP	NUMBER RP20-C-2	REV <b>A</b>
---------------	---------	-----------------	--------------

DEC FORM NO EN-01022-16-N370-(381)  
DRA 108

TITLE RP20 DUAL PORT INSTALLATION PROCEDURE

6. Install the logic door on the card cage of both DCU's.
4. EPO CABLING
1. Remove EPO jumper plug from CM-B J95 and install in CM-C J94 on both DCU "A" and DCU "B" AC power supplies.
  2. Connect one end of EPO cable (supplied with kit) (P/N 17-00095) to CM-B J95 on DCU "A" AC power supply.
  3. Repeat step 2, except use DCU "B" and second EPO cable.
  4. Remove left end panel of both master drive to gain access to the control module tailgate.
  5. Route the EPO cable from DCU "A" to the master drive of string "B" and connect it to J102 on the control module tailgate.
  6. Route the EPO cable from DCU "B" to the master drive of string "A" and connect it to J102 on the control module tailgate.
5. DUAL PORT CABLING
1. Label one end of the dual port cable (P/N 17-00218) (VP/N 343026XX) as "X".
  2. label the other end of the dual port cable as "Y".
  3. Repeat steps 1 and 2 for the second dual port cable.
  4. Connect one of the dual port interface cable labled "Y" to the "Y" interface (J114, J115) on the control module tailgate of string "A". Make sure that the "LIGHT" colored cable connector goes to the "DARK" colored cable receptacle, the "DARK" colored cable connector goes to the "LIGHT" colored cable receptacle on the control module tailgate.
  5. Connect the second dual port interface cable labled "X" to the "X" interface (J116, J117) on the control module tailgate of string "A". Make sure that the "LIGHT" colored cable connector goes to the "DARK" colored cable receptacle, the "DARK" colored cable connector goes to the "LIGHT" colored cable receptacle on the control module tailgate.
  6. Route both dual port interface cables to string "B" control module tailgate.

SIZE	CODE	NUMBER	REV
A	SP	RP20-C-2	A

TITLE RP20 DUAL PORT INSTALLATION PROCEDURE

7. Connect dual port interface cable labled "Y" to the "Y" interface (J114, J115) on the control module tailgate of string "B". Make sure that the "LIGHT" colored cable connector goes to the "DARK" colored cable receptacle, the "DARK" colored cable connector goes to the "LIGHT" colored cable receptacle on the control module tailgate.
  8. Connect dual port interface cable labled "X" to the "X" interface (J116, J117) on the control module tailgate of string "B". Make sure that the "LIGHT" colored cable connector goes to the "DARK" colored cable receptacle, the "DARK" colored cable connector goes to the "LIGHT" colored cable receptacle on the control module tailgate.
  9. Reinstall the end panel on both master drives.
6. DISK DRIVE CABLING
1. Remove the 40 pin terminator (VP/N 34303002) from J09 of string "A" master drive and install it in J02 (INTF Y) of the last drive in string "A".
  2. Remove the 50 pin terminator (VP/N 34302902) from J10 of string "A" master drive and install it in J01 (INTF Y) of the last drive in string "A".
  3. Install cable labeled P9/P10 into receptacle J07 and receptacle J08 of the master drive of string "A". This cable is inside the master drive dressed into the harness that runs between the control module tailgate and the mother board.
  4. Install special dual port terminator (P/N 12-18047) (VP/N 34303902) into receptacle J10 of the master drive in string "A".
  5. Install special dual port terminator (P/N 12-18045) (VP/N 34304002) into receptacle J10 of the master drive in string "A".
  6. Verify that both X/Y cables between drives are installed.
  7. Repeat section 6 DISK DRIVE CABLING for string "B".
7. CONTROL MODULE ADDRESS JUMPERS
- Install the jumpers as follows on the master drive control logic:
1. With 4 to 8 spindle dual ported, jumper the following:

SIZE	CODE	NUMBER	REV
A	SP	RP20-C-2	A

TITLE RP20 DUAL PORT INSTALLATION PROCEDURE

1. C08 D41 to ground, both master drives.
2. With 10 to 16 spindle dual ported, jumper the following:
  1. C08 D41 to ground, both master drives.
  2. C08 D15 to ground, both master drives.
  3. C08 D34 to ground, high order master (string "B") ONLY.
8. DISK DRIVE ADDRESSING
  1. Starting with the master drive in string "A", remove the DJ card from card location A09 of drive A.
  2. Remove the 14 pin address plug (VP/N 33065801) from location DA17 on the card.
  3. Install 16 Pin address plug number 0 (P/N 12-18046) (VP/N 34133201) in location DA17 on the card.
  4. Reinstall the DJ card in card location A09.
  5. Take a DK card from the upgrade kits and install a 16 pins address plug in location DA47 on the card. The address plug MUST have the same address as its corresponding DJ card.
  6. Install this DK card in location A10.
  7. Remove the DJ card from card location B09 of drive B.
  8. Remove the 14 pin address plug from location DA17 on the card.
  9. Install 16 Pin address plug number 1 (P/N 12-18046) in location DA17 on the card.
  10. Reinstall the DJ card in card location B09.
  11. Take the next DK card from the upgrade kits and install a 16 pins address plug in location DA47 on the card. The address plug MUST have the same address as its corresponding DJ card.
  12. Install this DK card in location B10.
  13. Repeat steps 1 through 12 for each slave drive in string "A". Numbering each drive in sequence not to exceed address 7 for the low order drives.

SIZE	CODE	NUMBER	REV
A	SP	RP20-C-2	A

TITLE RP20 DUAL PORT INSTALLATION PROCEDURE

14. Repeat entire Drive Addressing procedure for string "B". Start numbering the master drive drive with 8 and go to F.
9. GENERAL INFORMATION
  1. In a dual port configuration, both master drives (string "A" and "B") will have the same control module address of 00.
  2. The low order address drives (string "A") will have an address of 0 through 7.
  3. The high order address drives (string "B") will have an address of 8 through F.
  4. When running functional/inline diagnostics on the disk drives, use 50 for access to string "A" and 51 for access to string "B" from any DCU.
10. INLINES DIAGNOSTICS
  1. Power up the RP20 subsystem by putting the "ON/OFF" switch to the "ON" position on both DCUs.
  2. Run Functional/Inline microdiagnostics on all spindles from DCU "A".
  3. Run Functional/Inline microdiagnostics on all spindles from DCU "B".
  4. Verify all inline microdiagnostics will run prior to proceeding from both DCU's.
  5. Load functional/inline microdiagnostics EC.
  6. Verify the the Dual Port microdiagnostics test EC will run from both DCU's.
11. DCU ADDRESS TABLE
  1. Reference RP20 ADDRESS UPDATE/VERIFICATION PROCEDURE (A-SP-RP20-C-3) to rewrite the address table onto the Functional/Inline diskettes for dual ported drives. The address table will be identical for both DCU's.
  2. Rewrite the address table on any SPARE Functional Inline diskette that is available.

SIZE	CODE	NUMBER	REV
A	SP	RP20-C-2	A

**TITLE**            **RP20 DUAL PORT INSTALLATION PROCEDURE****12. DIAGNOSTIC CHECKOUT**

1. Load DFDXG into the system and verify that the CPU can see all the spindle in a dual port configuration.
2. Verify that the CPU can read and write data to the MAINTENANCE TRACK on each spindle. DO NOT DESTROY CUSTOMER DATA.

**SIZE**  
**A****CODE**  
SP**NUMBER**  
RP20-C-2**REV**  
**A**

This document contains confidential proprietary information of DEC. This information shall not be disclosed to persons outside the employ of DEC, except by DEC personnel so authorized by DEC, and only for use by such other persons in the design, production or manufacture of products for DEC. Copyright © Digital Equipment Corporation.

**DIGITAL EQUIPMENT CORPORATION**  
MAYNARD, MASSACHUSETTS

**ENGINEERING SPECIFICATION**

DATE 12 DEC 80

TITLE RP20 ADDRESS UPDATE/VERIFICATION PROCEDURE

REVISIONS

REV	DESCRIPTION	CHG NO	ORIG	DATE	APPD BY	DATE

ENG <i>Brian MacQuinn</i>	APPD <i>Brian MacQuinn</i>	SIZE A	CODE SP	NUMBER RP20-C-3	REV A
------------------------------	-------------------------------	-----------	------------	--------------------	----------

EN-1079A-16-R873-(392)  
DRA 107A

SHEET 1 OF 5

**ENGINEERING SPECIFICATION**

CONTINUATION SHEET

TITLE RP20 ADDRESS UPDATE/VERIFICATION PROCEDURE

1. EQUIPMENT REQUIRED

1. CX Printer Interface Card <P/N 29-23722>
2. 20 mA, 300 Baud Printer (LA30 or equivalent)

2. ADDRESS UPDATE

NOTE:

If any indicator lights or prompts are incorrect, check input parameters and repeat entire procedure.

1. Disable all RP20-H channel interface switches.
2. Verify that the INTF DISABLE lamp is lit.
3. Verify that the INLINE DISPLAY lights indicates C000. If not re-IMPL the functional/inline diskette.
4. Enter "30" in the DATA switches and raise EXECUTE switch. This will perform a system reset.
5. Verify that the lights indicate CF30.
6. Enter "C4" in the DATA switches and raise EXECUTE switch. This causes routine C4 to be loaded.
7. Verify that the lights indicate CAC4.
8. Enter "10" in the DATA switches and raise EXECUTE switch. This allows parameter entry mode.
9. Verify that the lights indicate DIC4.
10. Enter "33" in the DATA switches and raise EXECUTE switch. Rewrite the address table.
11. Verify that the lights indicate CAC4.
12. Enter "38" in the DATA switches and raise EXECUTE switch. This establish "standalone mode".
13. Verify that the lights indicate CAC4.
14. Enter "00" in the DATA switches and raise EXECUTE switch. This start routine C4. The Printer will prompt as follows:

SIZE A	CODE SP	NUMBER RP20-C-3	REV A
-----------	------------	--------------------	----------

DEC FORM NO EN-01022-16-N370-(381)  
DRA 108

SHEET 2 OF 5

TITLE RP20 ADDRESS UPDATE/VERIFICATION PROCEDURE

## ADDRESS TABLE ENTRY

DEV LEN FIF CHN

At this time the inline display will flash D100.

15. Enter "74" in the DATA switches and raise EXECUTE switch. This indicates dual ported RP20 drives are present.
16. Verify that the lights indicate D200 (flashing).
17. Enter "0X" in the DATA switches and raise EXECUTE switch. "X" equals the number of spindles (8 maximum) is a single string of disk drives.
18. Verify that the lights indicate D300 (flashing).
19. Enter "X0" in the DATA switches and raise EXECUTE switch. X equals the control module address of the master drive. It will be "0" for the low address disk drive # 0 through 7, and "1" for high order address disk drives # 8 through F.
20. Verify that the lights indicate D400.
21. Enter "XY" in the DATA switches and raise EXECUTE switch.
  1. X equals the address of the RP20-H. This is obtained from the DCU address switches KA07 1 through 4 located on the CI2 card in location B13 of the RP20-H. For dual port operation this address must be something other than "0".
  2. Y equals the starting address of each string of disk drives. That is "Y" will be "0" for the low order addressed drives, and "8" for the high order addressed drives.

The four parameters just entered for the first string of drives will be output to the printer as shown.

74 04 00 10

22. Verify that the lights indicate D100 (flashing) indicating requesting second set of parameter inputs.
23. Repeat steps 15 through 21 for the for the second string of disk drives.

SIZE A	CODE SP	NUMBER RP20-C-3	REV A
-----------	------------	--------------------	----------

SHEET 3 OF 5

TITLE RP20 ADDRESS UPDATE/VERIFICATION PROCEDURE

24. The four parameters just entered for the second string of drives will be output to the printer as shown.

74 04 10 18

25. Verify that the lights indicate D100 (flashing) indicating requesting next set of parameter inputs.
26. Enter "FF" in the DATA switches and raise EXECUTE switch. FF indicates all parameters have been entered and to write the table on the diskette. The table will also be output to the printer as follows.

CHN FIF DEV

ADR ADR TYPE

10	00	8650	NATIVE
11	01	8650	NATIVE
12	02	8650	NATIVE
13	03	8650	NATIVE
18	10	8650	NATIVE
19	11	8650	NATIVE
1A	12	8650	NATIVE
1B	13	8650	NATIVE

27. Verify that the lights indicate FFFF.
28. Save the output and tape it to the inside of the rear door for future use.
29. Raise the RESET switch.
30. Repeat this entire procedure for the other functional/inline diskette in the second RP20-H controller. The parameters entered will be the same for both address tables.
31. Repeat this entire procedure for any spare functional/inline diskette that will be used as a backup for the original.
32. Label all functional/diskettes indicating address covered, and RP20-H used on if there are more than two RP20 subsystems at a sight.
33. Reinstall the updated functional/inline diskette in the floppy drive.
34. Raise the IMPL switch to load the new address into the RP20-H memory.

SIZE A	CODE SP	NUMBER RP20-C-3	REV A
-----------	------------	--------------------	----------

SHEET 4 OF 5

TITLE RP20 ADDRESS UPDATE/VERIFICATION PROCEDURE

35. Do not remove the functional/inline diskette. This diskette must be installed in the floppy drive and enabled at all times.
36. Enable Channel Interface Switch "A" on the for of both RP20-H controllers.

### 3. ADDRESS VERIFICATION

This section enables a F-S Engineer to obtain a listing of an address table that exist on an unknown functional/inline diskette. Or to verify the table was written correctly.

1. Repeat section 2. ADDRESS UPDATE steps 1 through 14, except in step 10 enter "66" into the data switches. Print the address table.
2. After the prompts have been output to the printer, D100 flashing in the lights, enter "FF" in the DATA switches and raise the EXECUTE switch. This will cause the address table to be output to the printer.
3. Verify that the lights indicate FFFF.
4. Raise the RESET switch.
5. If no correction are in order raise the IMPL switch to reload the address into the RP20-H memory.
6. If correction are needed repeat entire section 2. ADDRESS UPDATE.

SIZE	CODE
A	SP

NUMBER
RP20-C-3

REV
A

LINE ITEM	DOCUMENT NUMBER	PART NUMBER	DESCRIPTION	QUANTITY PER VARIATION	
				00	01
1	1	2923694-00	37PCBA, DK	2	2
2	2	1218046-00	ADDRESS PLUGS, 0-F FOR RP20	1	-
3	3	1700218-01	CABLE, DUAL PORT INTERFACE, 20FT	1	-
4	4	1218045-00	TERMINATOR 40PIN MUX	1	-
5	5	1218047-00	TERMINATOR 50PIN MUX	1	-
6	6	1700095-04	CABLE, 6 COND, 25FT	1	-

REVISION HISTORY			BASIC PART NO: 7018290		DRN: JOE DONAHER		DATE: 28-OCT-80		D I G I T A L			
ENG	ECO NUMBER	REV	SECTION A OF A	CHK'D:	J. HUSON	DATE:	19-NOV-80	TITLE PARTS LIST				
	INITIAL	A	SECTION, VARIATION INDEX					UPGRADE KIT, RP20-A DUAL PORT				
			[A] 00,01					DOCUMENT NUMBER				
			[B]	DES.ENG.:	B MCQUAIN	DATE:	15-DEC-80	SIZE:	CODE:	NUMBER	REV	
			[C]	RESP.ENG.:	B MCQUAIN	DATE:	15-DEC-80	K	PL	7018290-0-DBP	A	
			[D]	MFG.ENG.:	T BARRETT	DATE:	15-DEC-80	ASSEMBLY NUMBER:		TOP DOCUMENT NUMBER:	FILE NAME:	EDIT #
			[E]	B-DD-RP20-C-0		B-DD-RP20-C-0		B-DD-RP20-C-0		Z1708A.PLS	13	
			[F]	"THIS DRAWING AND SPECIFICATIONS HEREIN, ARE THE PROPERTY OF DIGITAL EQUIPMENT CORPORATION AND SHALL NOT BE REPRODUCED OR COPIED OR USED IN WHOLE OR IN PART AS THE BASIS FOR THE MANUFACTURE OR SALE OF ITEMS WITHOUT WRITTEN PERMISSION. COPYRIGHT (C) 1980, DIGITAL EQUIPMENT CORPORATION"								







**DIGITAL EQUIPMENT CORPORATION**  
MAYNARD, MASSACHUSETTS

**ENGINEERING SPECIFICATION**

DATE 12 DEC 80

TITLE RP20 DUAL CHANNEL INSTALLATION PROCEDURE

REVISIONS

REV	DESCRIPTION	CHG NO	ORIG	DATE	APPD BY	DATE

Digital Equipment Corporation.

Copyright ©

ENG <i>Bruce Owen</i>	APPD <i>Bruce Owen</i>	SIZE <b>A</b>	CODE SP	NUMBER RP20-D-2	REV <b>A</b>
-----------------------	------------------------	---------------	---------	-----------------	--------------

EN-1079A-16-R873-(392)  
DRA 107A

SHEET 1 OF 3

**ENGINEERING SPECIFICATION**

CONTINUATION SHEET

TITLE RP20 DUAL CHANNEL INSTALLATION PROCEDURE

1. INITIAL CHECKOUT

1. Obtain customer permission to install Dual Channel Upgrade Kit.
2. Verify all Control Unit microdiagnostics run on the DCU prior to installing upgrade kit.
3. Correct all problems/failures before proceeding.

2. DCU ADDRESSING

1. Power down the DCU by putting the ON/OFF switch to the "OFF" position.
2. Remove the bottom logic door of the DCU.
3. Remove the CI2 card (P/N 29-23734) from card location B13.
4. Record the switch settings of KA07 (DCU Address Switches).
5. Record the switch settings of BA27 (Priority Data In Switches).
6. Reinstall the CI2 card in location B13.
7. Set switches KA07 and BA27 of the CI2 card supplied with the upgrade kit to the value obtained in steps 4 and 5.
8. Install the CI2 card in card location B11 of the DCU.

3. EPO CABLING

1. Install Channel EPO cable (P/N 70-10483) from second DX20 in J88-CHAN B of the AC Power Supply.

4. RP20-H CHECKOUT

1. Power up the DCU by putting the ON/OFF switch to the "ON" position.
2. Run Channel Interface Wraparound Test (01) as outlined in the RP20 USERS GUIDE (EK-0RP20-UG-001) with the following exceptions:

SIZE <b>A</b>	CODE SP	NUMBER RP20-D-2	REV <b>A</b>
---------------	---------	-----------------	--------------

DEC FORM NO EN-01022-16-N370-(381)  
DRA 108

SHEET 2 OF 3

TITLE RP20 DUAL CHANNEL INSTALLATION PROCEDURE

1. Use Channel B for BUS/TAG receptacles J30/J31.
2. Use Channel B J32 for TAG terminator, J33 for BUS terminator.
3. Remove only the Channel Wraparound test cable.

## 5. DUAL CHANNEL CABLING

1. Route second DX20 Channel Cable P/N 70-10078 to RP20-HA/HB Channel B interface.
2. Connect connector labeled **1, 2** to J31 (BUS IN).
3. Connect connector labeled **3, 4** to J30 (TAG IN).
4. Verify BUS terminator P/N 12-12171 is installed in J33 (BUS OUT).
5. Verify TAG terminator P/N 12-12172 is installed in J32 (TAG OUT).

## 6. DIAGNOSTIC CHECKOUT

1. Power up the entire RP20 subsystem.
2. Enable Channel Interface switch "B" on the front operator panel of the DCU by putting it in the on position.
3. Load diagnostic DFDXG and test out the second RH20, DX20, Channel B interface.

SIZE  
**A**CODE  
SPNUMBER  
RP20-D-2REV  
**A**

LINE ITEM	DOCUMENT NUMBER	PART NUMBER	DESCRIPTION	QUANTITY PER VARIATION
1	1	2923734-00	37PCBA, CI2	1

REVISION HISTORY		BASIC PART NO: 7018292		DRN:	DATE:	D I G I T A L			
ENG:	ECO NUMBER	REV	SECTION A OF A	JOE DONAHER	28 OCT 80	PARTS LIST			
---	INITIAL	A	SECTION, VARIATION INDEX	CHK'D: J, HUSON	DATE: 19-NOV-80	TITLE			
			[A] 00	DES,ENG,: B MCQUAIN	DATE: 15-DEC-80	UPGRADE KIT, RP20-H DUAL ACCESS			
			[B]	RESP,ENG,: B MCQUAIN	DATE: 15-DEC-80	DOCUMENT NUMBER			
			[C]	MFG,ENG,: T BARRETT	DATE: 15-DEC-80	SIZE	CODE	NUMBER	REV
			[D]	ASSEMBLY NUMBER:	TOP DOCUMENT NUMBER:	K	PL	7018292-0-DBP	A
			[E]	B-DD-RP20-D-0	B-DD-RP20-D-0	FILE NAME:		EDIT #	
			[F]			Z1707A,PLS		7	

"THIS DRAWING AND SPECIFICATIONS HEREIN, ARE THE PROPERTY OF DIGITAL EQUIPMENT CORPORATION AND SHALL NOT BE REPRODUCED OR COPIED OR USED IN WHOLE OR IN PART AS THE BASIS FOR THE MANUFACTURE OR SALE OF ITEMS WITHOUT WRITTEN PERMISSION, COPYRIGHT (C) 1980, DIGITAL EQUIPMENT CORPORATION"





LINE ITEM	DOCUMENT NUMBER	PART NUMBER	DESCRIPTION	QUANTITY PER VARIATION	
				HA	HB
1	D=AD=7018291=0=0	7018291=00	RP20=H SINGLE ACCESS DCU 60HZ	1	0
2	D=AD=7018291=0=0	7018291=01	RP20=H SINGLE ACCESS DCU 50HZ	0	1

REVISION HISTORY			BASIC PART NO:	ORP20	DRN:	JOE DONAHER	DATE:	20=NOV=80	D I G I T A L			
ENG:	ECO NUMBER	REV	SECTION A OF A		CHK'D:	J HUSON	DATE:	20=NOV=80	TITLE PARTS LIST			
---	INITIAL	A	SECTION, VARIATION INDEX		CHK'D:	J HUSON	DATE:	20=NOV=80	SINGLE ACCESS DCU			
			[A] HA,HB		DES,ENG,:	B MCQUAIN	DATE:	15=DEC=80	DOCUMENT NUMBER			
			[B]		RESP,ENG,:	B MCQUAIN	DATE:	15=DEC=80	SIZE:	CODE:	NUMBER	REV
			[C]		MFG,ENG,:	T BARRETT	DATE:	15=DEC=80	K	PL	RP20=H=DBP	A
			[D]		ASSEMBLY NUMBER:	B=DD=RP20=H=0	TOP DOCUMENT NUMBER:	B=DD=RP20=H=0	FILE NAME:	Z1934A,PLS		EDIT #
			[E]									6
			[F]									

"THIS DRAWING AND SPECIFICATIONS HEREIN, ARE THE PROPERTY OF DIGITAL EQUIPMENT CORPORATION AND SHALL NOT BE REPRODUCED OR COPIED OR USED IN WHOLE OR IN PART AS THE BASIS FOR THE MANUFACTURE OR SALE OF ITEMS WITHOUT WRITTEN PERMISSION, COPYRIGHT (C) 1980, DIGITAL EQUIPMENT CORPORATION "



"THIS DRAWING AND SPECIFICATIONS, HEREIN, ARE THE PROPERTY OF DIGITAL EQUIPMENT CORPORATION AND SHALL NOT BE REPRODUCED OR COPIED OR USED IN WHOLE OR IN PART AS THE BASIS FOR THE MANUFACTURE OR SALE OF ITEMS WITHOUT WRITTEN PERMISSION.  
 COPYRIGHT © 1980, DIGITAL EQUIPMENT CORPORATION"

0-0-1628101 2

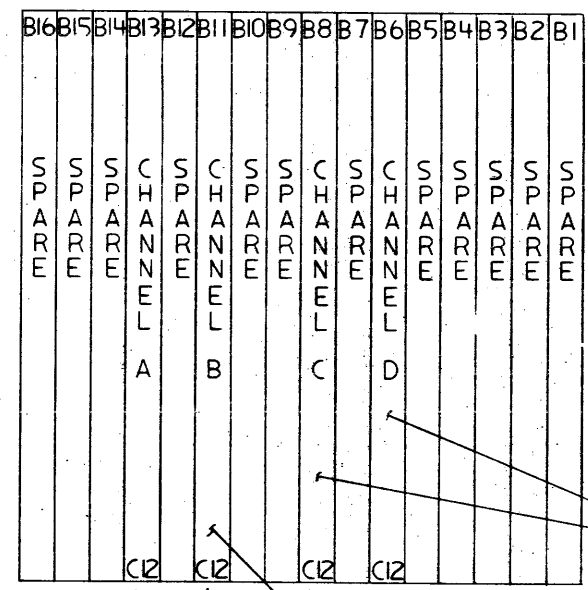
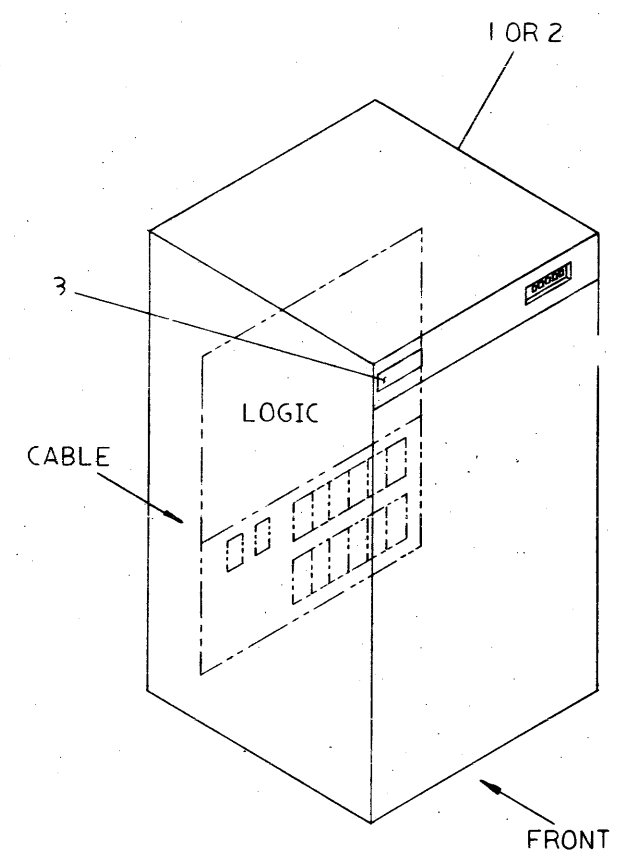

SINGLE ACCESS DUAL ACCESS THIS MODULE REMOVED FOR RP20-H

FRONT VIEW

CAUTION: OFF SHEET PARTS LIST EXISTS. SEE K-PL-7016291-0-DBP

REV.	
CHG	

THIRD ANGLE PROJECTION	DESCRIPTION	DWG. PART NO.	ITEM NO.																	
	UNLESS OTHERWISE SPECIFIED DIMENSIONS ARE IN INCHES																			
REMOVE BURRS AND BREAK SHARP CORNERS	ANGLES 40° 30'	CLASS OF ACCURACY	NOMINAL DIMENSION RANGE INCHES																	
	DO NOT SCALE DWG	SURFACE QUALITY IN MICROINCHES	<table border="1"> <tr> <th>TO</th> <th>OVER</th> <th>TO</th> <th>OVER</th> <th>TO</th> <th>OVER</th> </tr> <tr> <td>0.2</td> <td>1.2</td> <td>1.2</td> <td>4.0</td> <td>12.0</td> <td>48.0</td> </tr> <tr> <td>0.2</td> <td>1.2</td> <td>1.2</td> <td>4.0</td> <td>12.0</td> <td>48.0</td> </tr> </table>	TO	OVER	TO	OVER	TO	OVER	0.2	1.2	1.2	4.0	12.0	48.0	0.2	1.2	1.2	4.0	12.0
TO			OVER	TO	OVER	TO	OVER													
0.2	1.2	1.2	4.0	12.0	48.0															
0.2	1.2	1.2	4.0	12.0	48.0															
MATERIAL	QUANTITY & VARIATION	PREPARED																		
FINISH	THIRD ANGLE PROJECTION	DRN. <i>J. Huson</i>	FIRST USED ON																	
	REMOVE BURRS AND BREAK SHARP CORNERS	CHK'D <i>J. Huson</i>																		
	DO NOT SCALE DWG	ENG. <i>J. Huson</i>	TITLE																	
		PROJ. ENG. <i>J. Huson</i>	RP20-H SINGLE ACCESS DCU																	
		PROD. <i>J. Huson</i>																		
			SIZE CODE NUMBER REV.																	
			D AD 7016291-0-0 A																	
			SHEET OF 1																	

LINE ITEM	DOCUMENT NUMBER	PART NUMBER	DESCRIPTION	QUANTITY PER VARIATION	
				00	01
1	1	3017688-00	CNTRLR,DUAL ACCESS 208/230V 60HZ	1	0
2	2	3017688-01	CNTRLR,DUAL ACCESS 235/408V 50HZ	0	1
3	3	3617952-01	LABEL,DIGITAL LOGO 2"X5.75"	1	1

REVISION HISTORY			BASIC PART NO: 7018291			D I G I T A L					
ENG	ECO NUMBER	REV	SECTION A OF A	DRN:	J,DONAHY	DATE:	28-OCT-80	TITLE			
---	INITIAL	A	SECTION, VARIATION INDEX (A) 00,01	CHK'D:	J,HUSON	DATE:	19-NOV-80	PARTS LIST			
			(B)	DES,ENG,:	B MCQUAIN	DATE:	15-DEC-80	RP20-H SINGLE ACCESS DCU			
			(C)	RESP,ENG,:	B MCQUAIN	DATE:	15-DEC-80	DOCUMENT NUMBER			
			(D)	MFG,ENG,:	T BARRETT	DATE:	15-DEC-80	SIZE:	CODE:	NUMBER	REV
			(E)	ASSEMBLY NUMBER:	D-AD-7018291-0-0	TOP DOCUMENT NUMBER:	B-DD-RP20-H-0	K	PL	7018291-0-DBP	A
			(F)			FILE NAME:	Z1706A,PLS				EDIT #
											5

"THIS DRAWING AND SPECIFICATIONS HEREIN, ARE THE PROPERTY OF DIGITAL EQUIPMENT CORPORATION AND SHALL NOT BE REPRODUCED OR COPIED OR USED IN WHOLE OR IN PART AS THE BASIS FOR THE MANUFACTURE OR SALE OF ITEMS WITHOUT WRITTEN PERMISSION. COPYRIGHT (C) 1980, DIGITAL EQUIPMENT CORPORATION"