

KL10 Field Maintenance Print Set Supplement

KL10 BLOCK DIAGRAMS

The block diagrams in this manual are selected from the *KL10 Technical Descriptions*. These drawings are not under ECO control. They are intended to be used as a supplement to the *KL10 Field Maintenance Print Set*.

Copyright © 1976 by Digital Equipment Corporation.

The material in this manual is for informational purposes and is subject to change without notice.

Digital Equipment Corporation assumes no responsibility for any errors which may appear in this manual.

FIGURE No.

42	DECsystem-1080 Block Diagram (Typical)	63
43	Main Processor Subsystem Block Diagram (Sheet 1 of 2)	64
	Main Processor Subsystem Block Diagram (Sheet 2 of 2)	
44	Detail Channel Interface Block Diagram	66
45	DIA20 Detailed Block Diagram	67
46	DMA20 Functional Block Diagram	68
47	DMA20 Detailed Logic Block Diagram	69
48	DTE20 Functional Block Diagram (Simplified)	70
49	DTE20 Data and Address Paths, Block Diagram	71

The following are trademarks of Digital Equipment Corporation, Maynard, Massachusetts:

DEC	DECtape	PDP
DECCOMM	DECUS	RSTS
DECsystem-10	DIGITAL	TYPESET-8
DECSYSTEM-20	MASSBUS	TYPESET-11
		UNIBUS

Figure No.	Title	Page
1	DECSYSTEM-20 Block Diagram - Typical	1
2	Main Processor Subsystem Block Diagram	3
3	Composite Interface Drawing	7
4	Front End Channel Functional Block Diagram	9
5	RH20/Massbus Drive Functional Block Diagram	15
6	Meter Board Block Diagram	16
7	EBox Functional Block Diagram	17
8	EBox RAM Structures Interface and Controls Block Diagram	18
9	Register Interconnection Diagram	19
10	EBox Data and Address Paths	20
11	EBox, MBox, and EBus Control Diagram	21
12	EBus Control, Hybrid Flow Diagram	22
13	MBox Overall Block Diagram	22
14	MBox RAM Structures Interfaces and Controls Block Diagram	24
15	MBox Functional Block Diagram	25
16	MBox Address and Data Path Block Diagram	27
17	MBox Control Logic Block Diagram	28
18	MBox Channel Control Logic Block Diagram	30
19	MBox Address Parity, NXM and SBus Error, Path Diagram	33
20	MBox Data and Page Table, Path Diagram	34
21	MBox Cache Cycle Control Functional Flow Diagram	35
22	MBox Channel RAM Cycle Control Functional Flow Diagram	41
23	DTE Simplified Functional Block Diagram	44
24	DTE Simplified Control Block Diagram	45
25	DTE20 Address and Data Paths Block Diagram	46
26	DTE20 Detailed Control Block Diagram	47
27	DTE20 EBus and EBuffer Mixers	48
28	DTE20 Interface Address and Access Control Simplified	49
29	DTE20 Simplified Diagnostic Functional Diagram	50
30	MA20 Internal Memory	51
31	MA20 Module Utilization	52
32	MA20 Functional Block Diagram	53
33	MA20 Controller Detailed Block Diagram	54
34	MA20 Bus and Cycle Control	55
35	MA20 Storage Module Detailed Block Diagram	56
36	MA20 Memory Selection 4-Way Interleave Mode	57
37	MA20 Memory Selection 2-Way Interleave Mode	58
38	MA20 Memory Selection Non-Interleave Mode	59
39	MA20 SBus Write Timing Diagram	60
40	MA20 SBus Read Timing Diagram	61
41	MA20 SBus RMW Timing Diagram	62

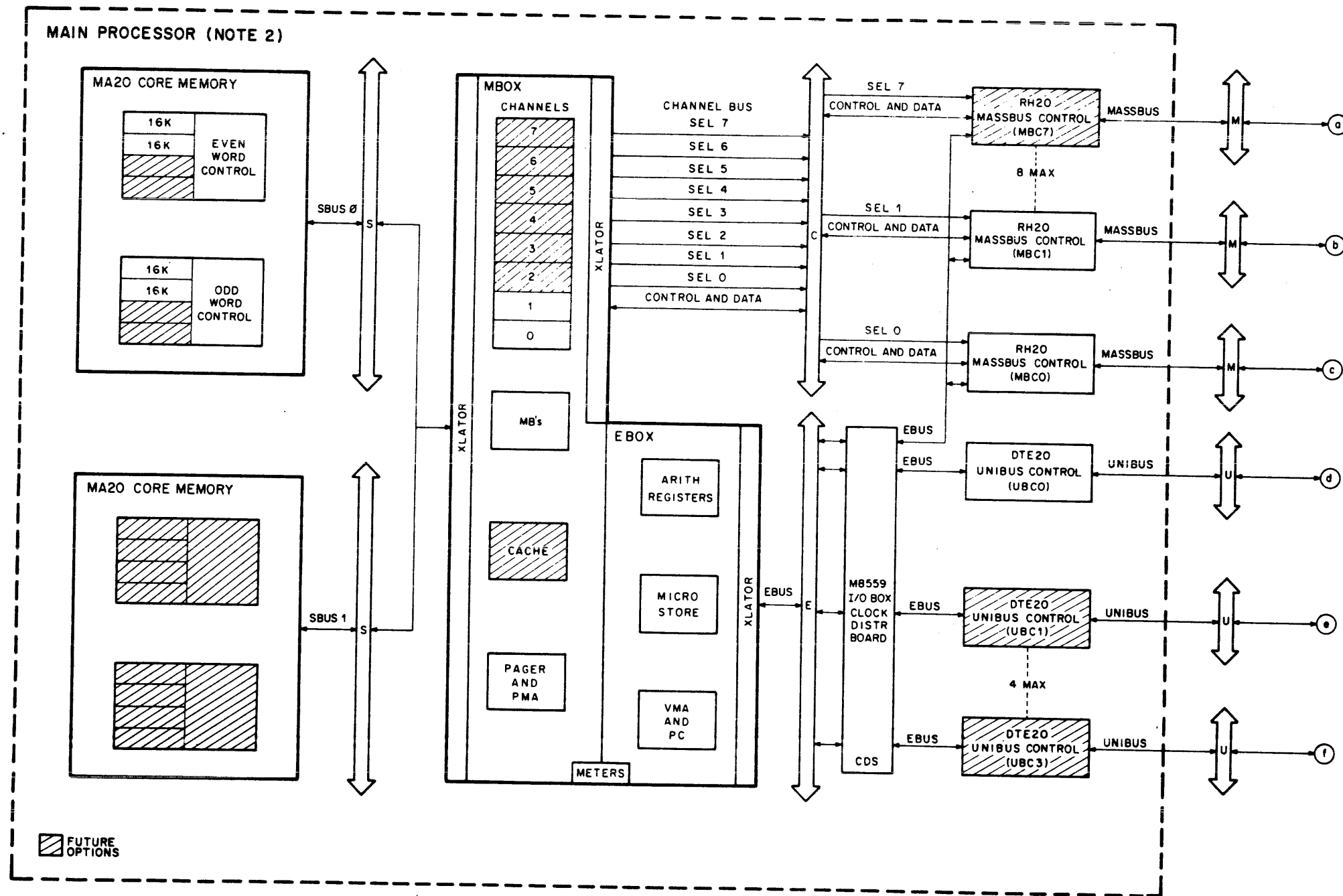

10-2077

Figure 1 DECSYSTEM-20 Block Diagram - Typical (Sheet 1 of 2)

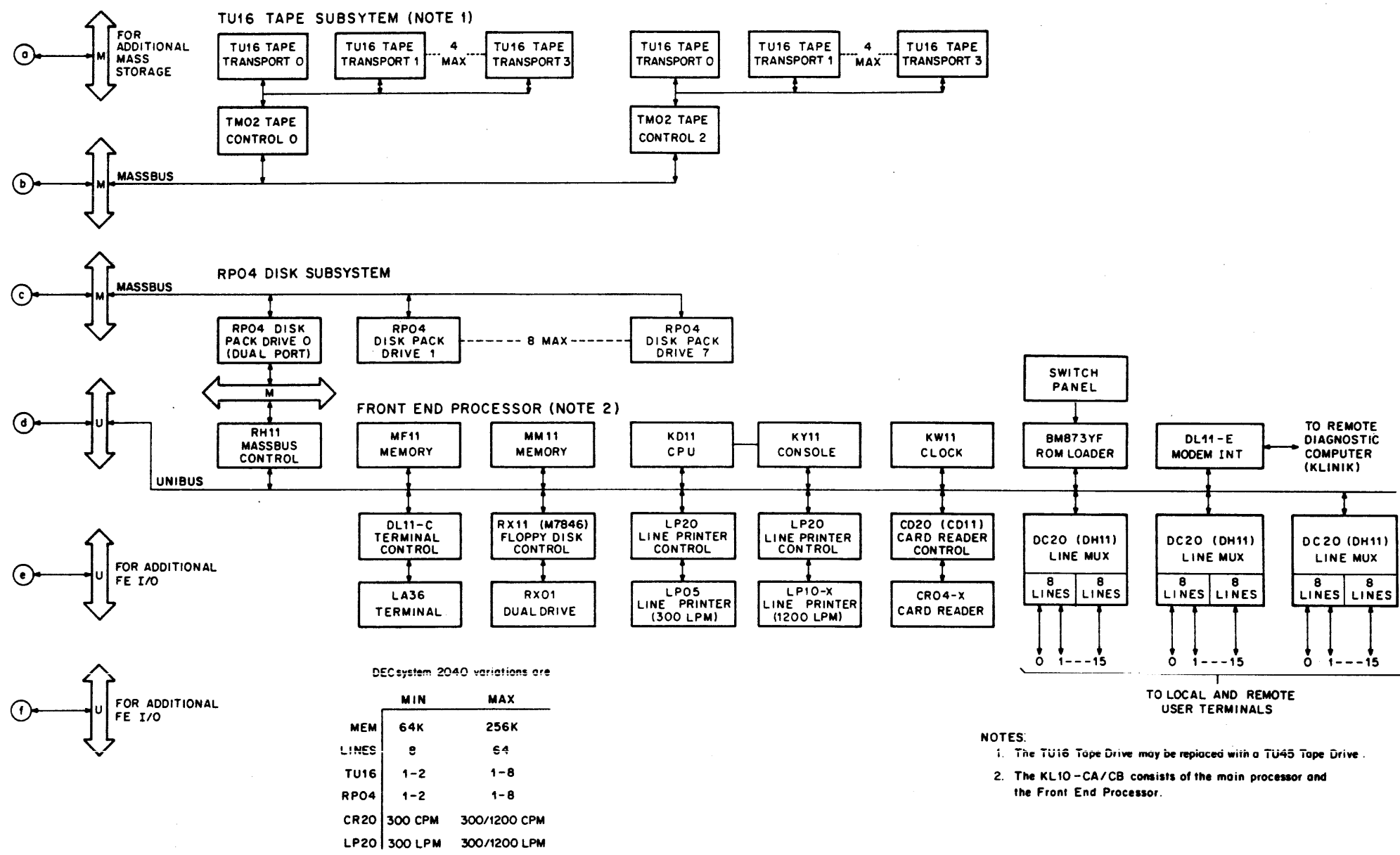
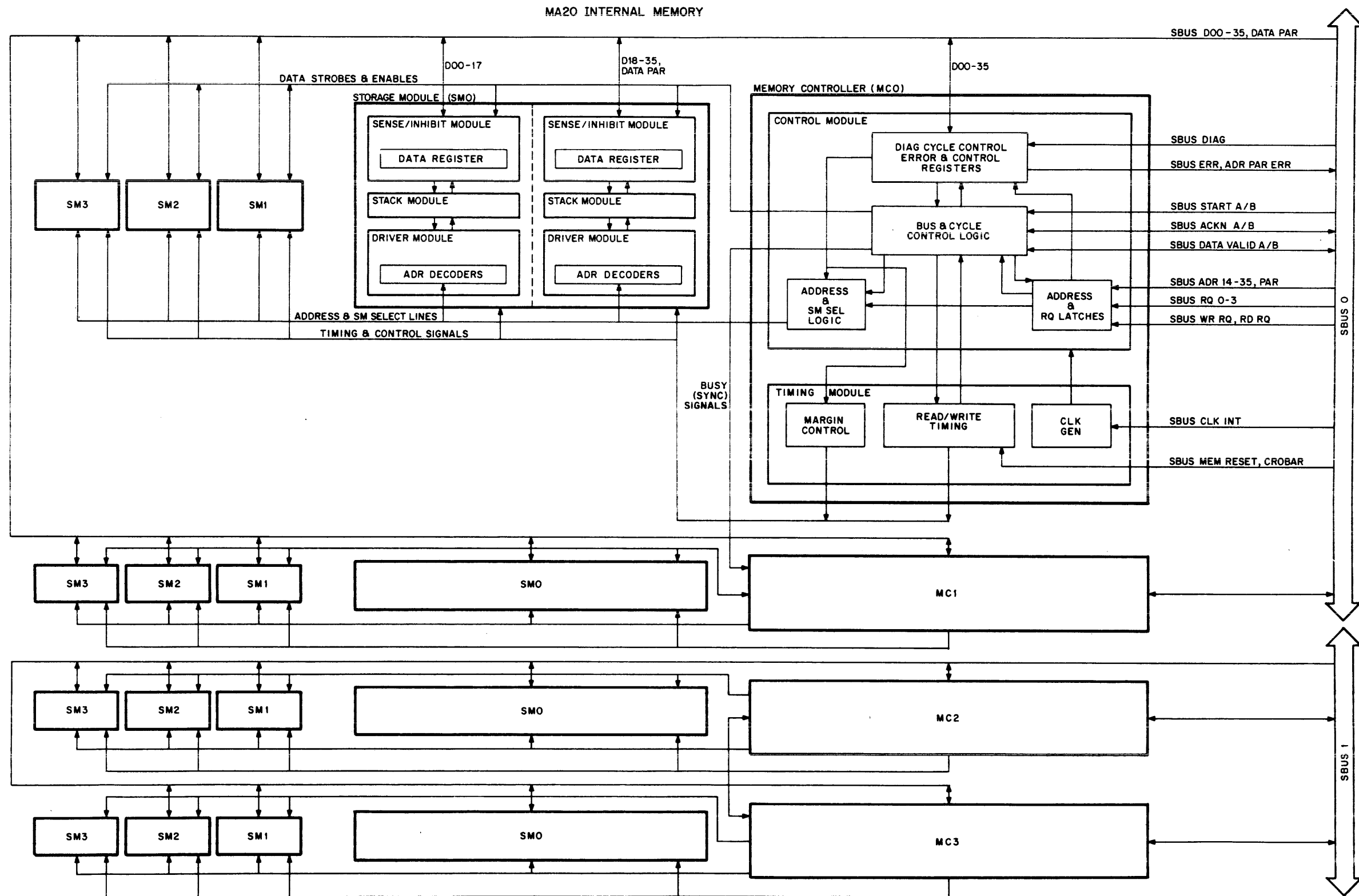
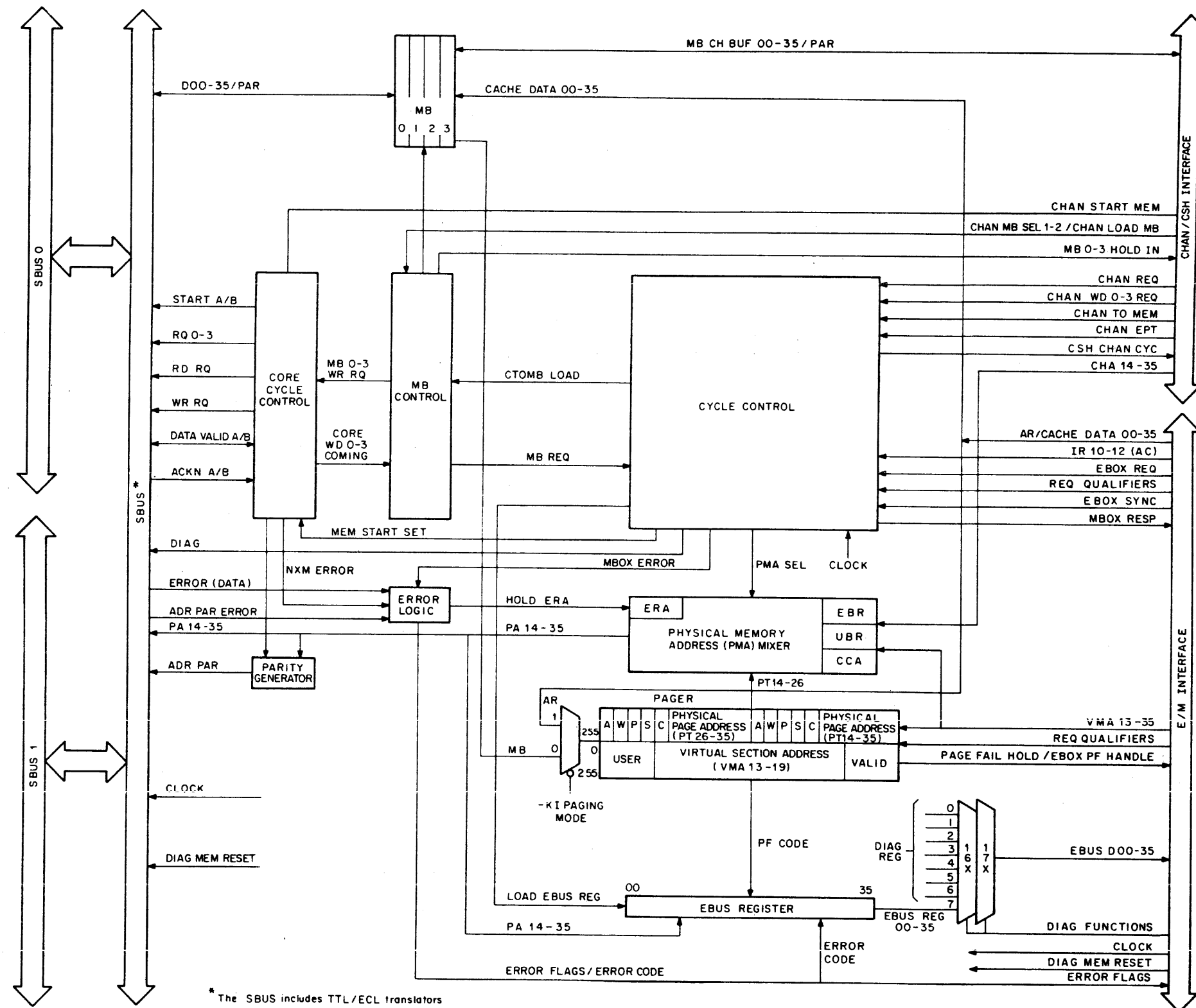

Figure 1 DECSYSTEM-20 Block Diagram - Typical (Sheet 2 of 2)



10-2127

Figure 2 Main Processor Subsystem Block Diagram (Sheet 1 of 4)



10-2015

Figure 2 Main Processor Subsystem Block Diagram (Sheet 2 of 4)

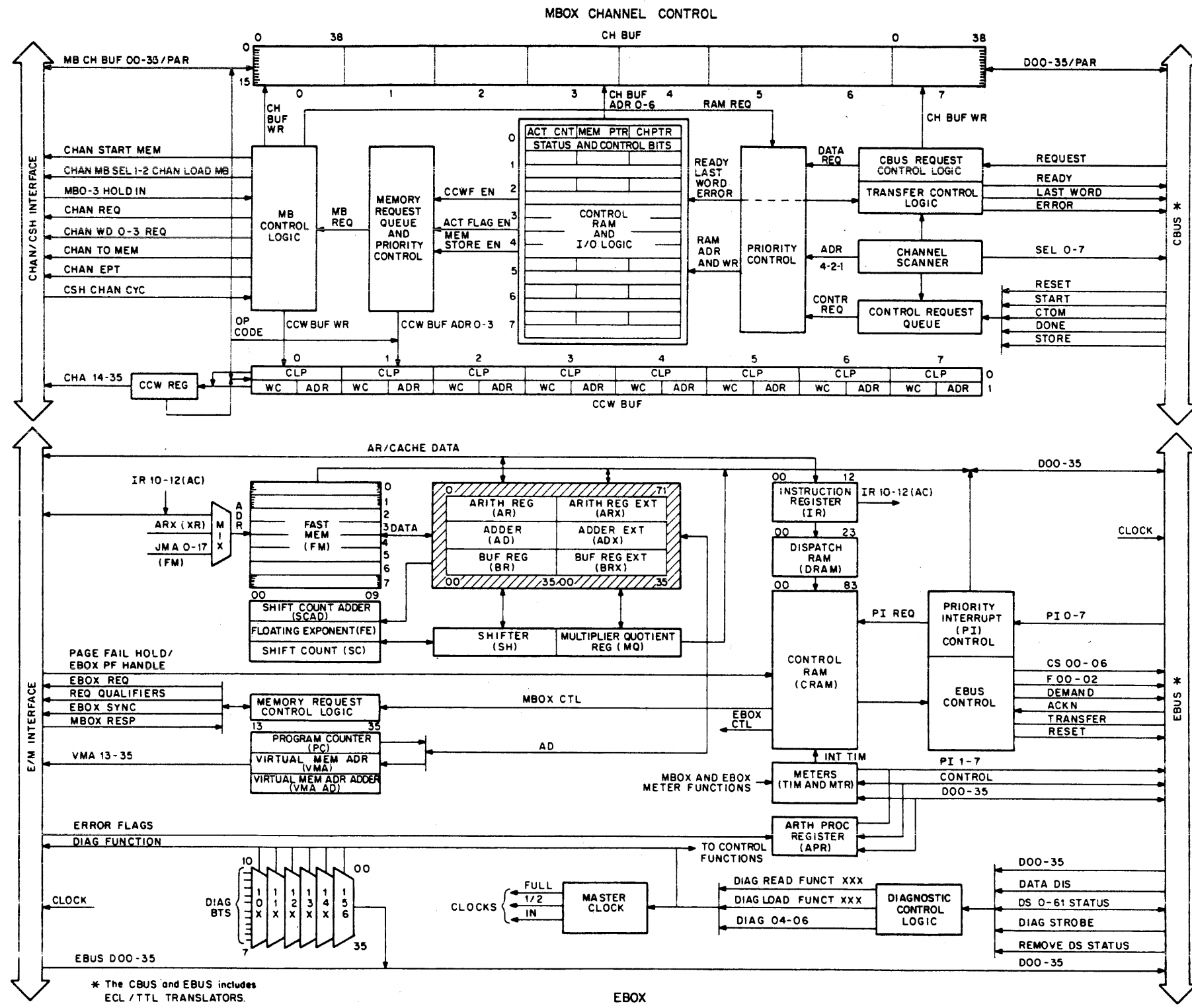

Figure 2 Main Processor Subsystem Block Diagram (Sheet 3 of 4)

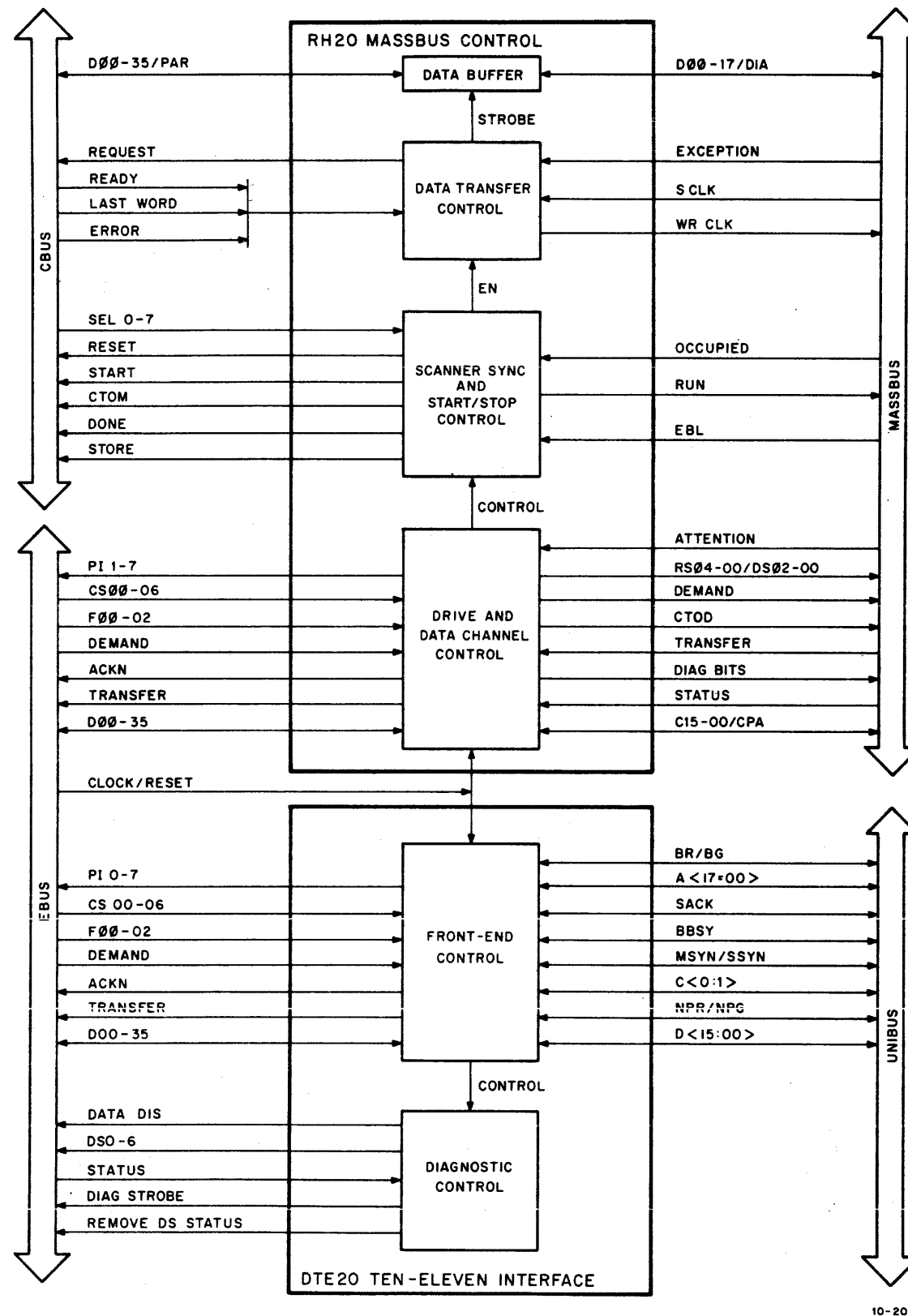

Figure 2 Main Processor Subsystem Block Diagram (Sheet 4 of 4)

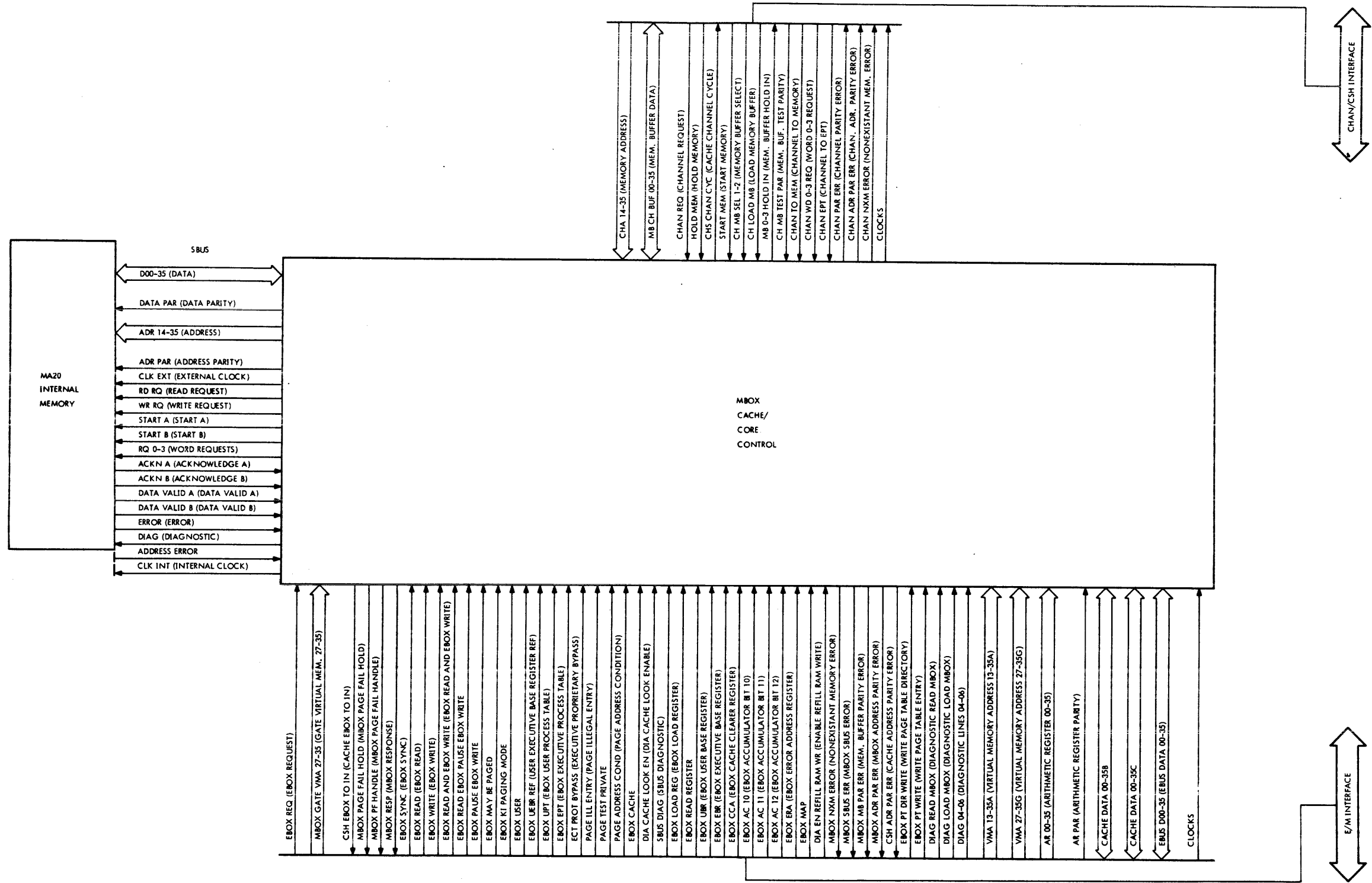
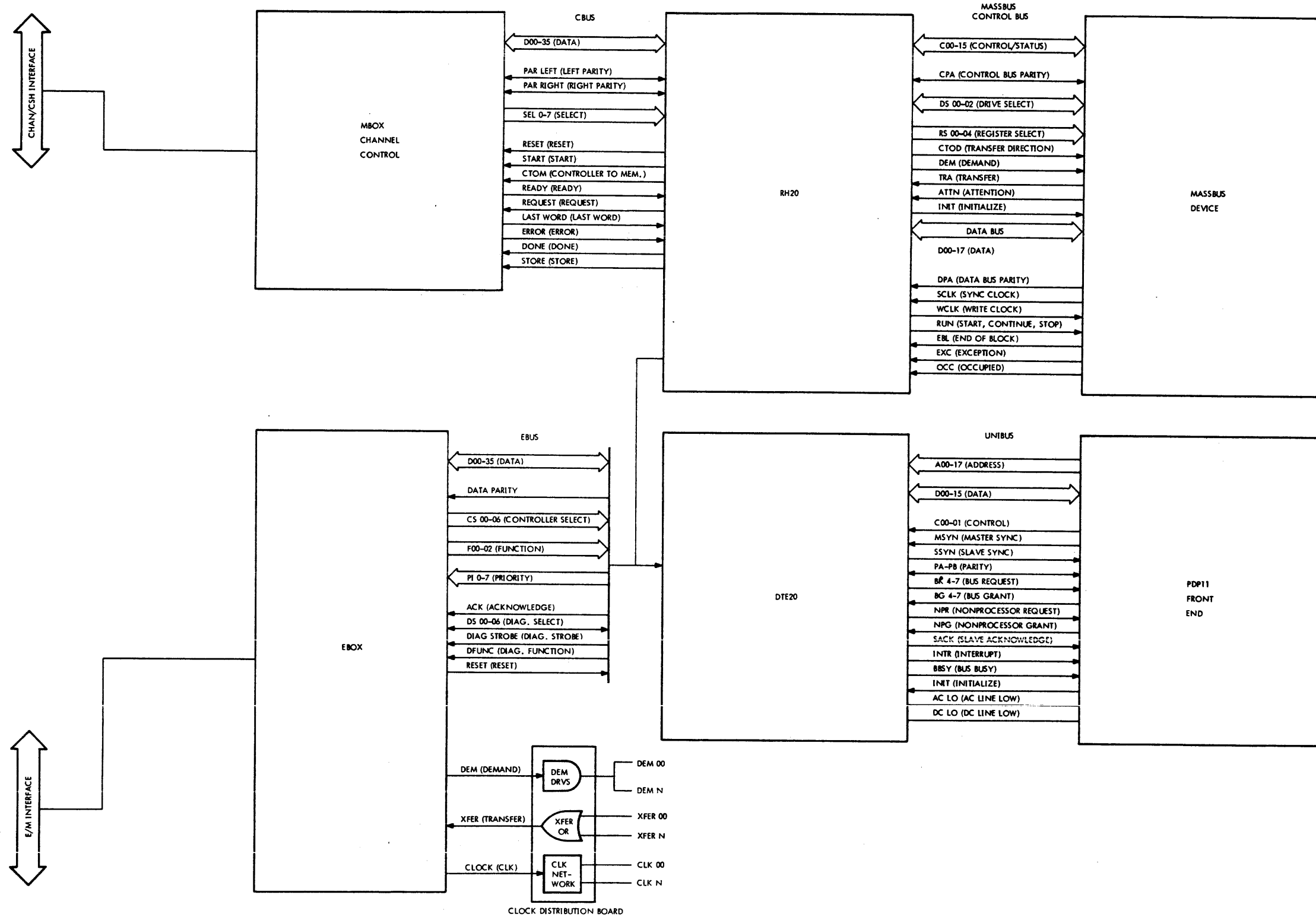
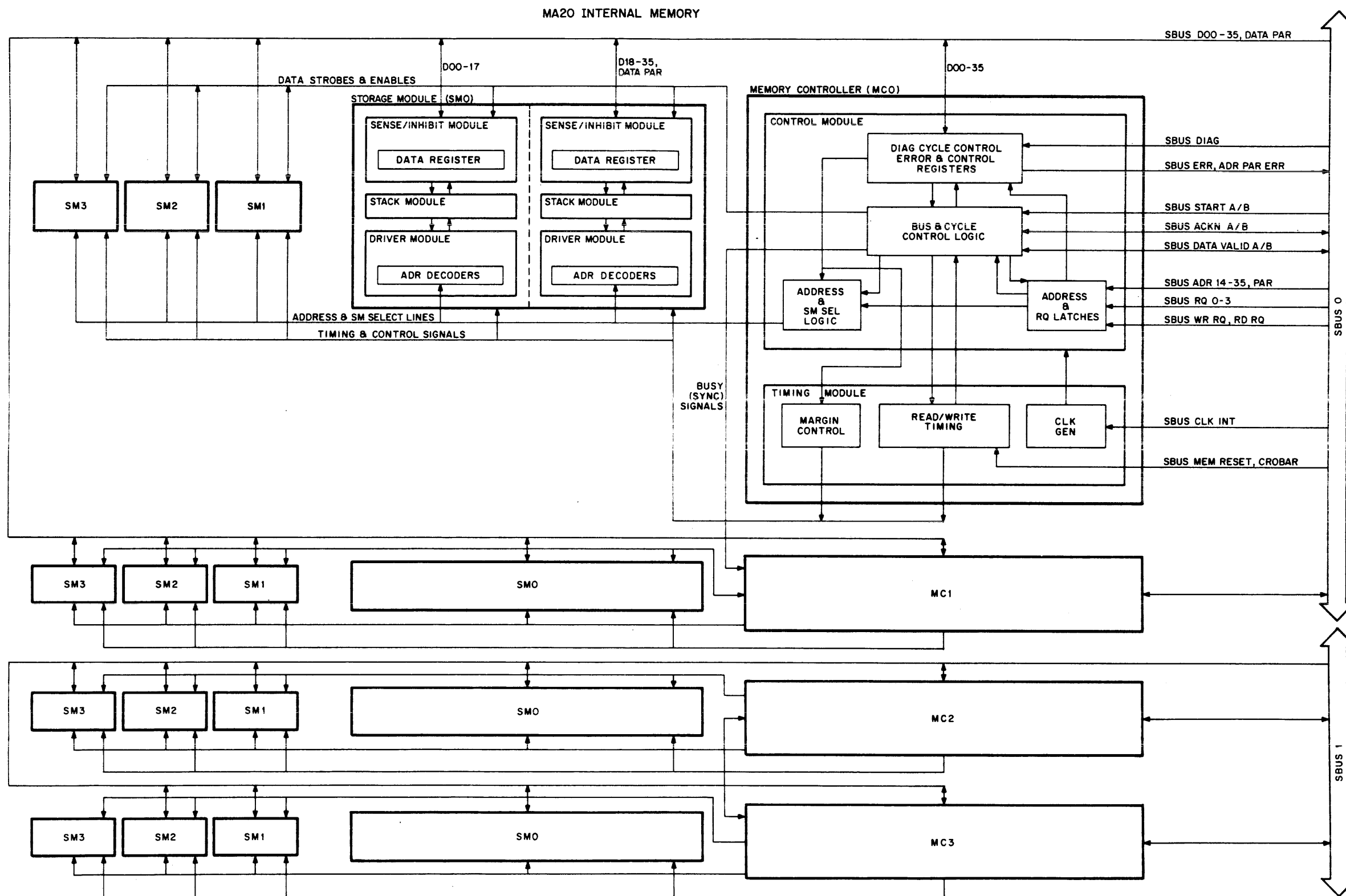

Figure 3 Composite Interface Drawing (Sheet 1 of 2)



10-2174

Figure 3 Composite Interface Drawing (Sheet 2 of 2)



10-2127

Figure 4 Front End Channel Functional Block Diagram (Sheet 1 of 6)

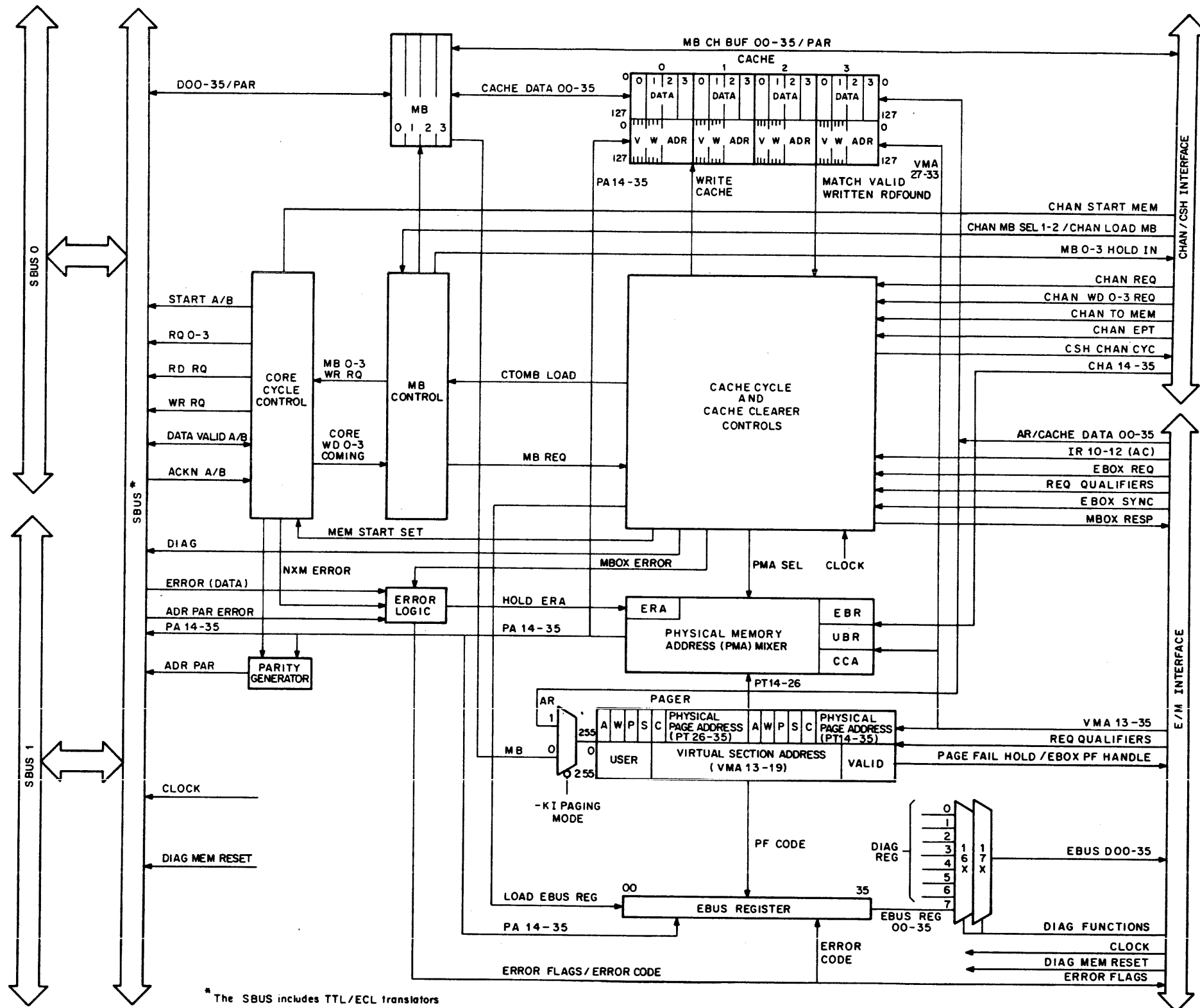

10-2147

Figure 4 Front End Channel Functional Block Diagram (Sheet 2 of 6)

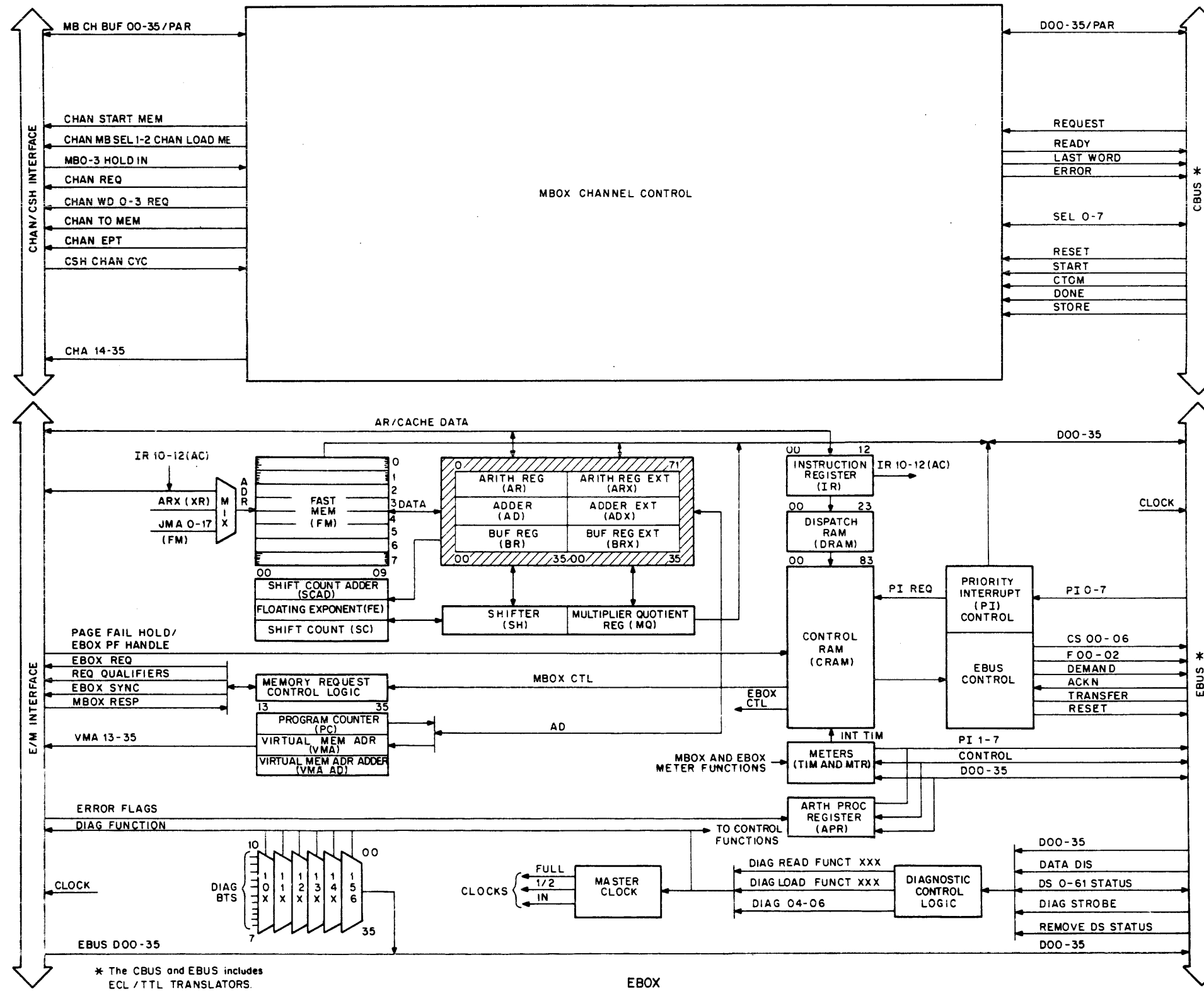
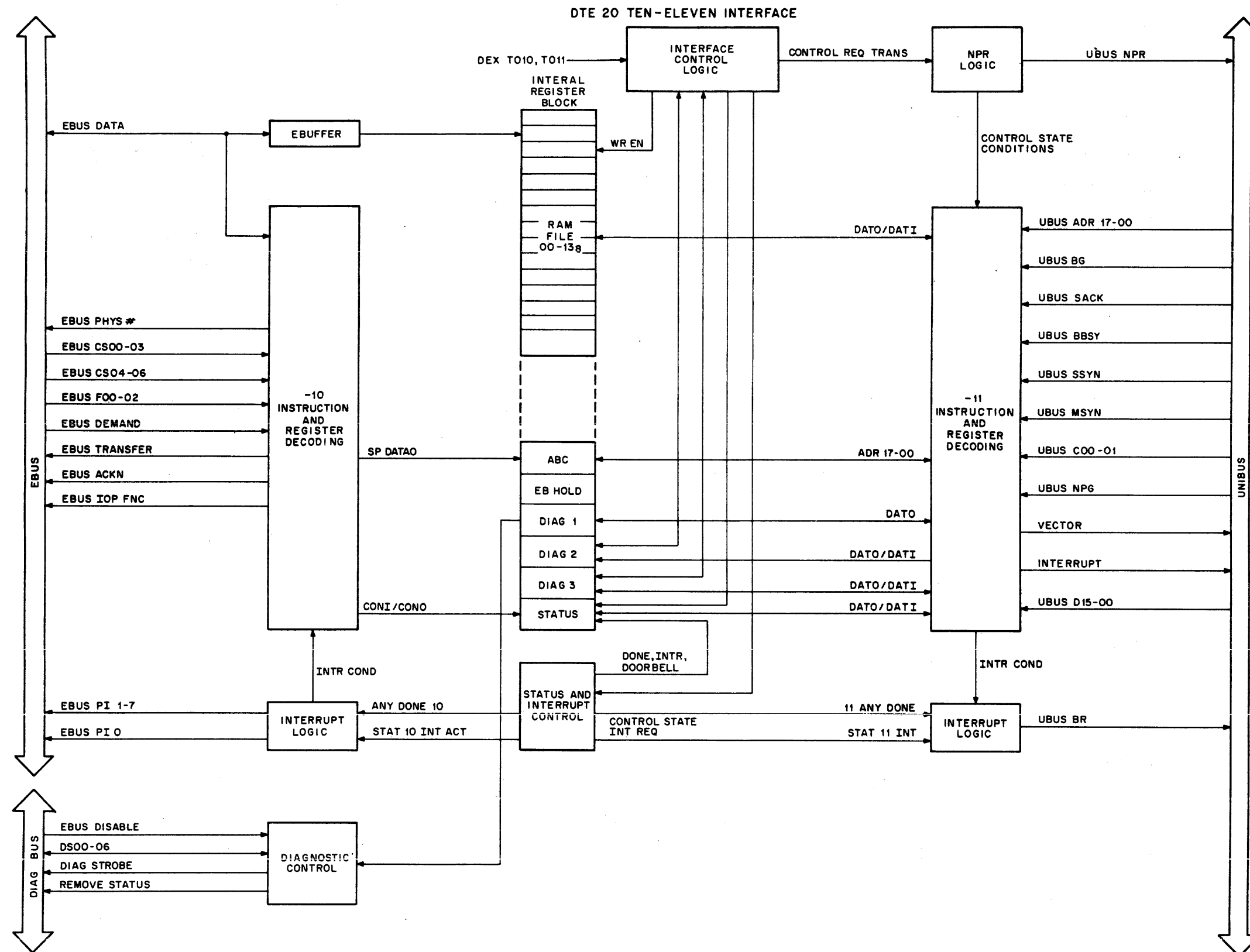

Figure 4 Front End Channel Functional Block Diagram (Sheet 3 of 6)



10-2220

Figure 4 Front End Channel Functional Block Diagram (Sheet 4 of 6)

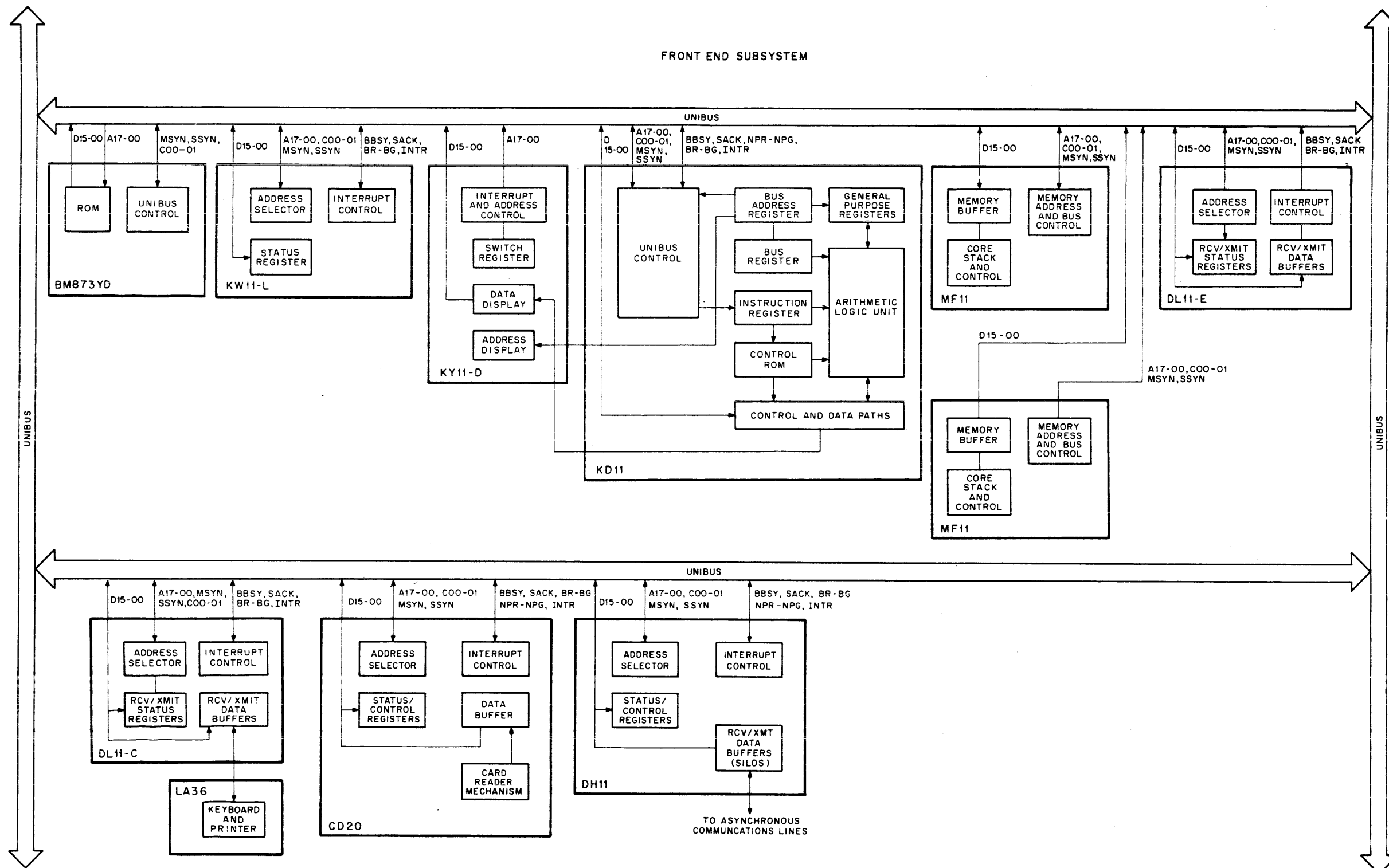
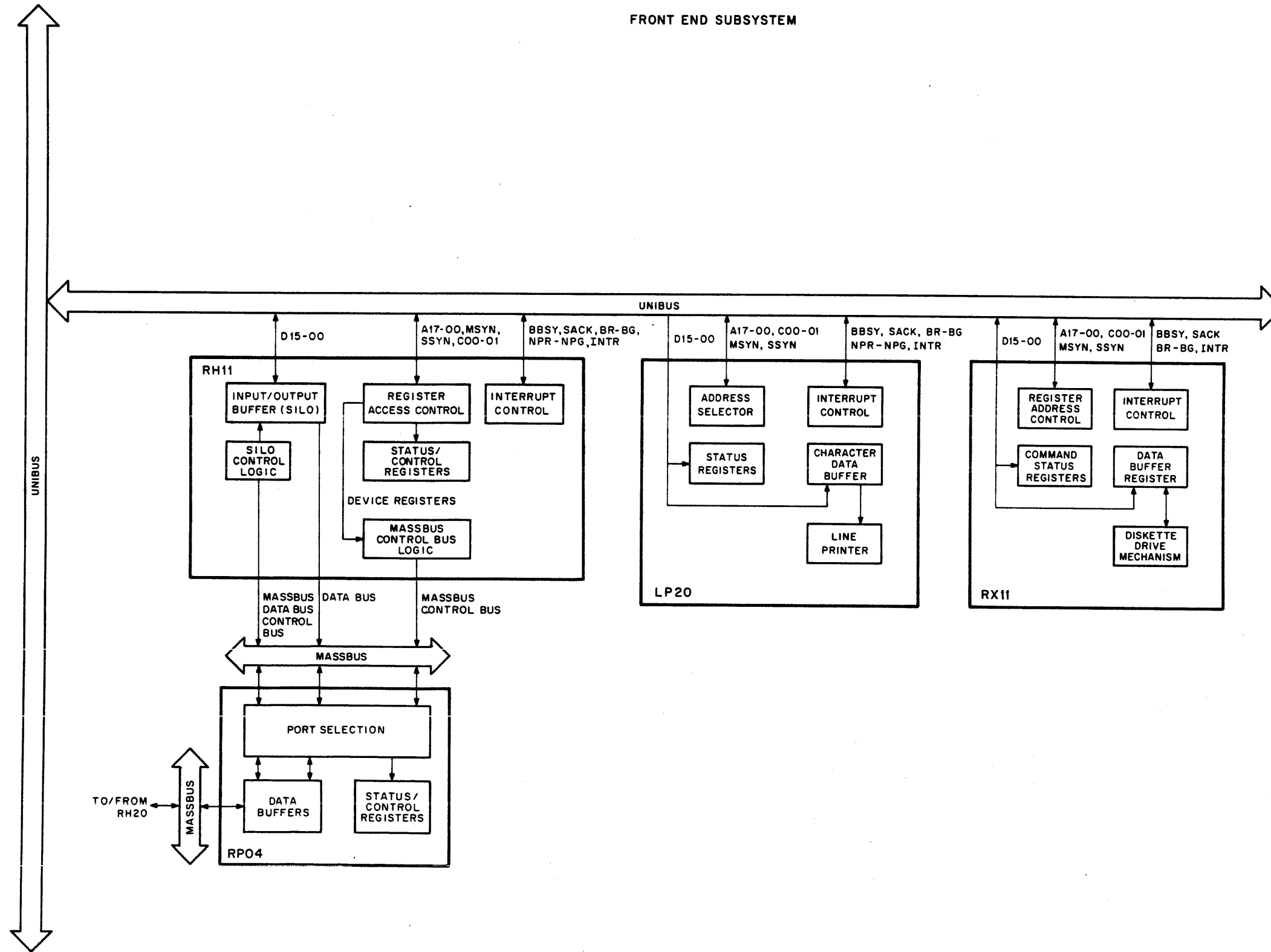

Figure 4 Front End Channel Functional Block Diagram (Sheet 5 of 6)

FRONT END SUBSYSTEM



10-2222

Figure 4 Front End Channel Functional Block Diagram (Sheet 6 of 6)

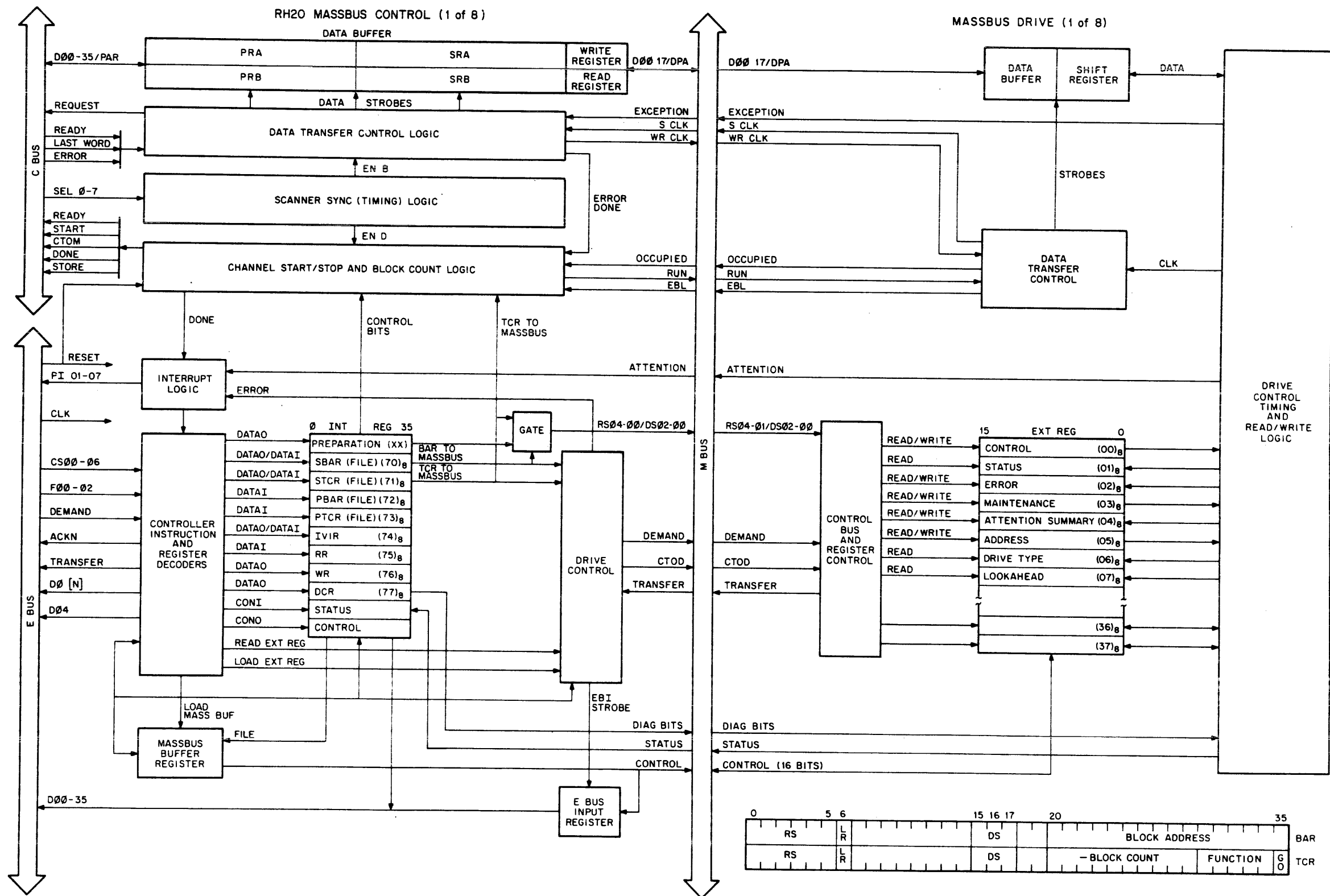
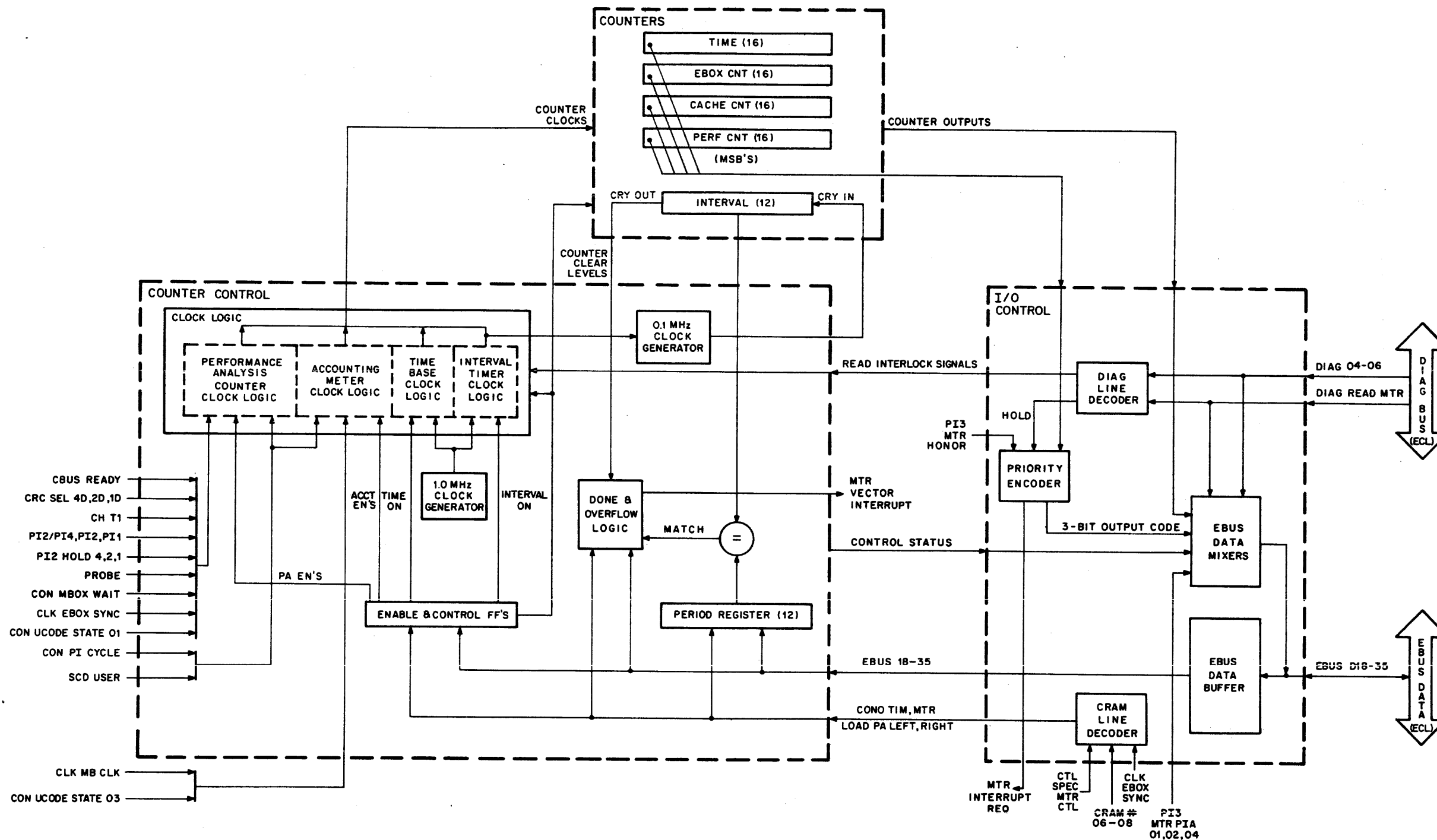

Figure 5 RH20/Massbus Drive Functional Block Diagram



10-1775

Figure 6 Meter Board Block Diagram

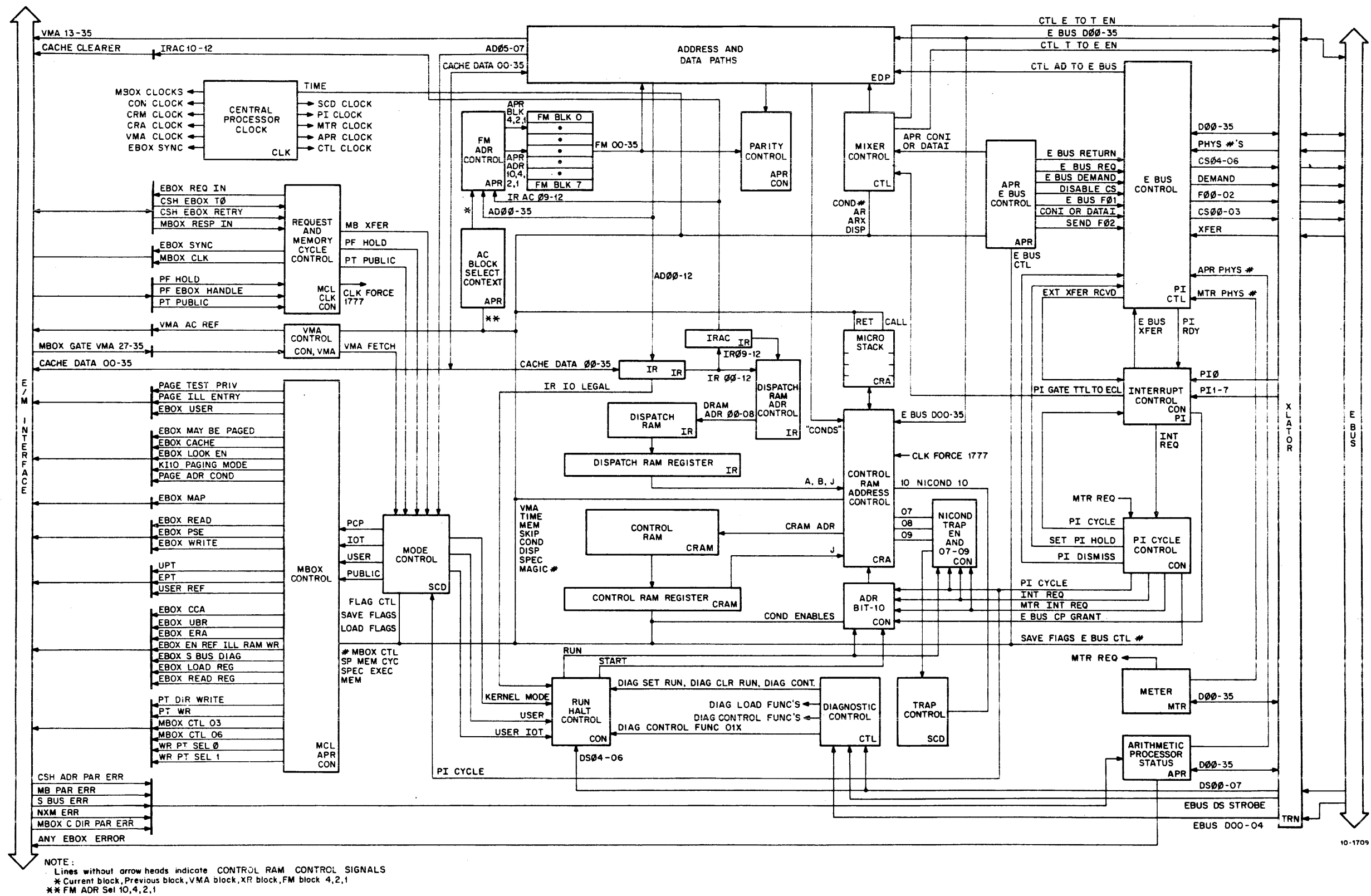
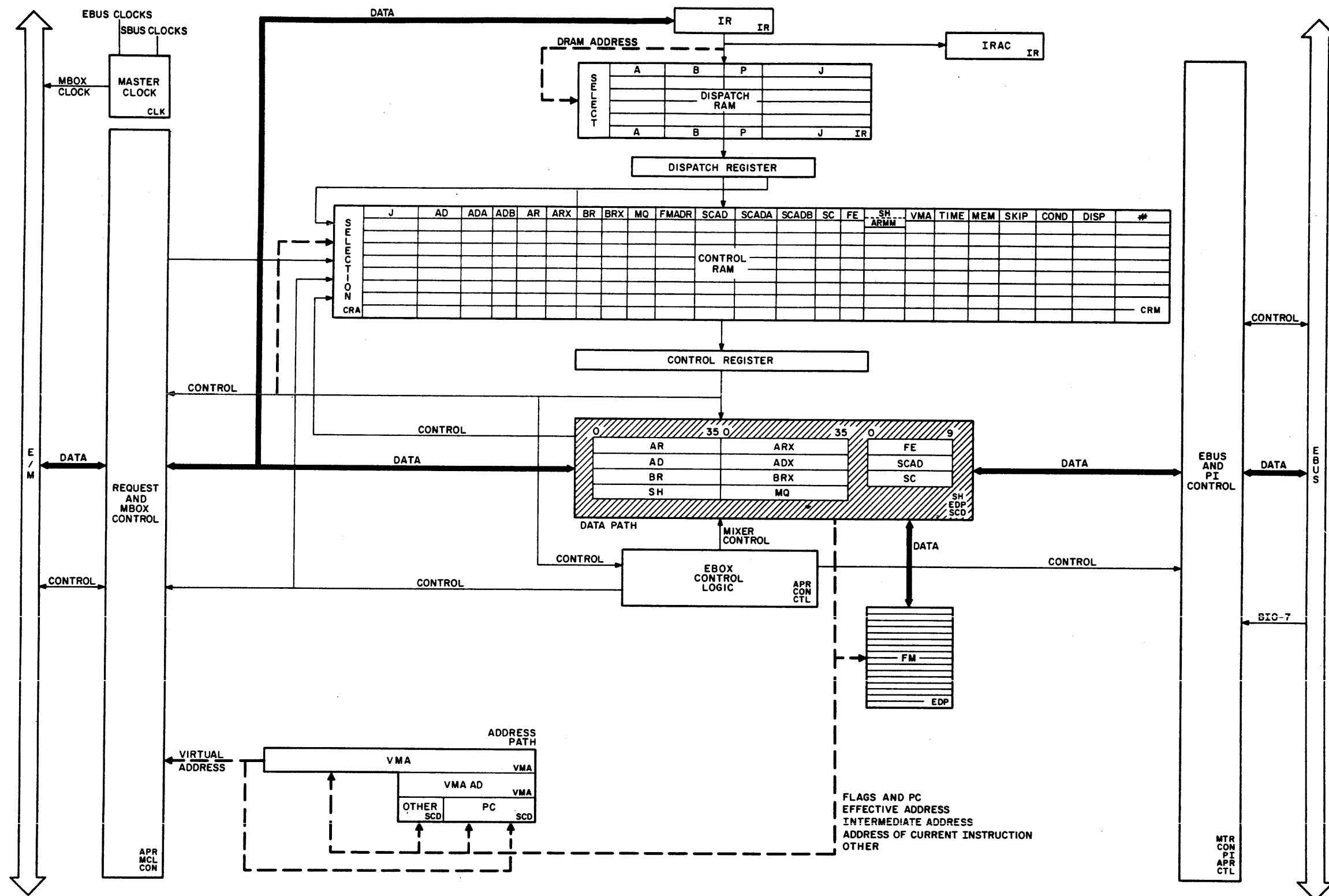

Figure 7 EBox Functional Block Diagram



10-2179

Figure 8 EBox RAM Structures Interface and Controls Block Diagram

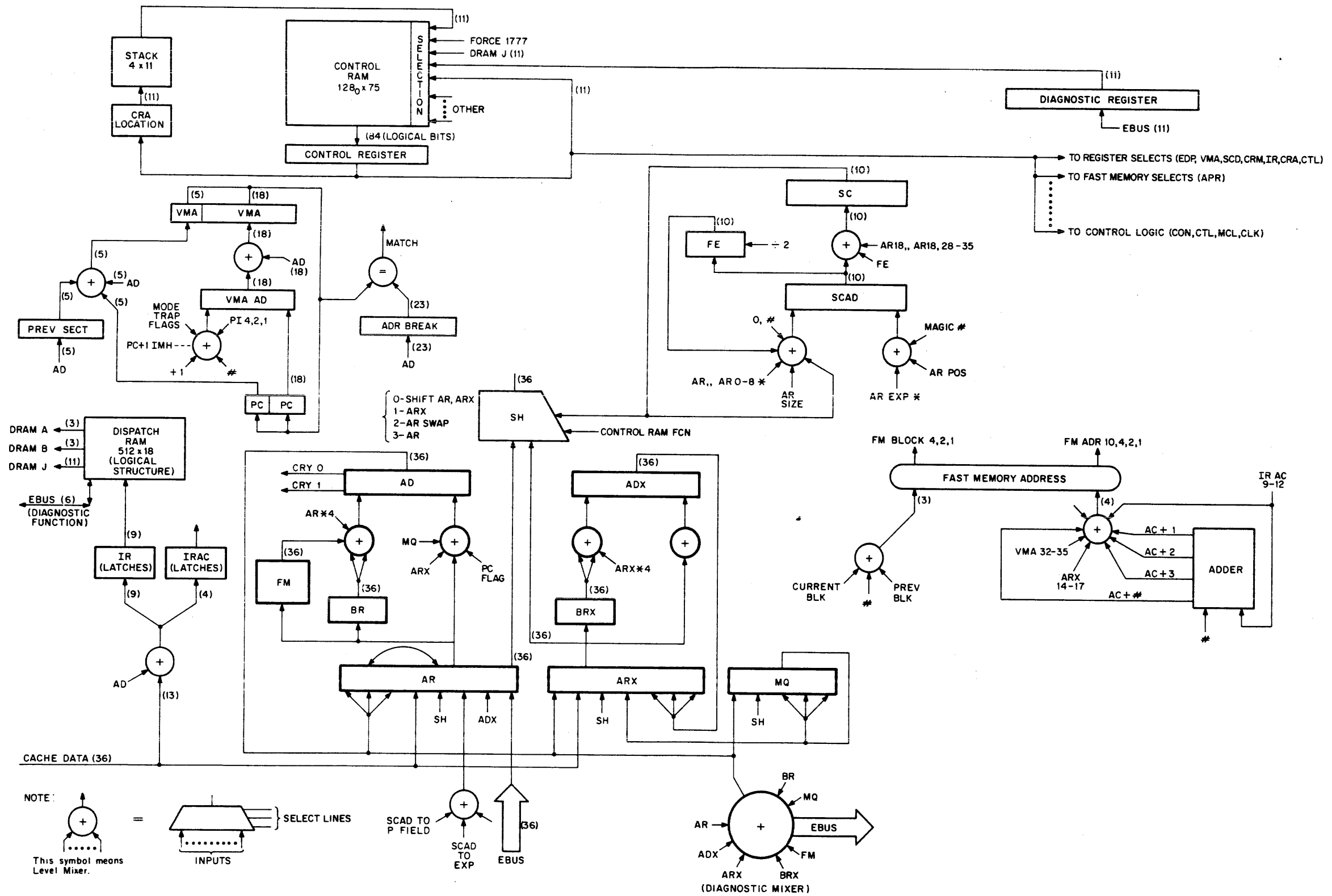

Figure 9 Register Interconnection Diagram

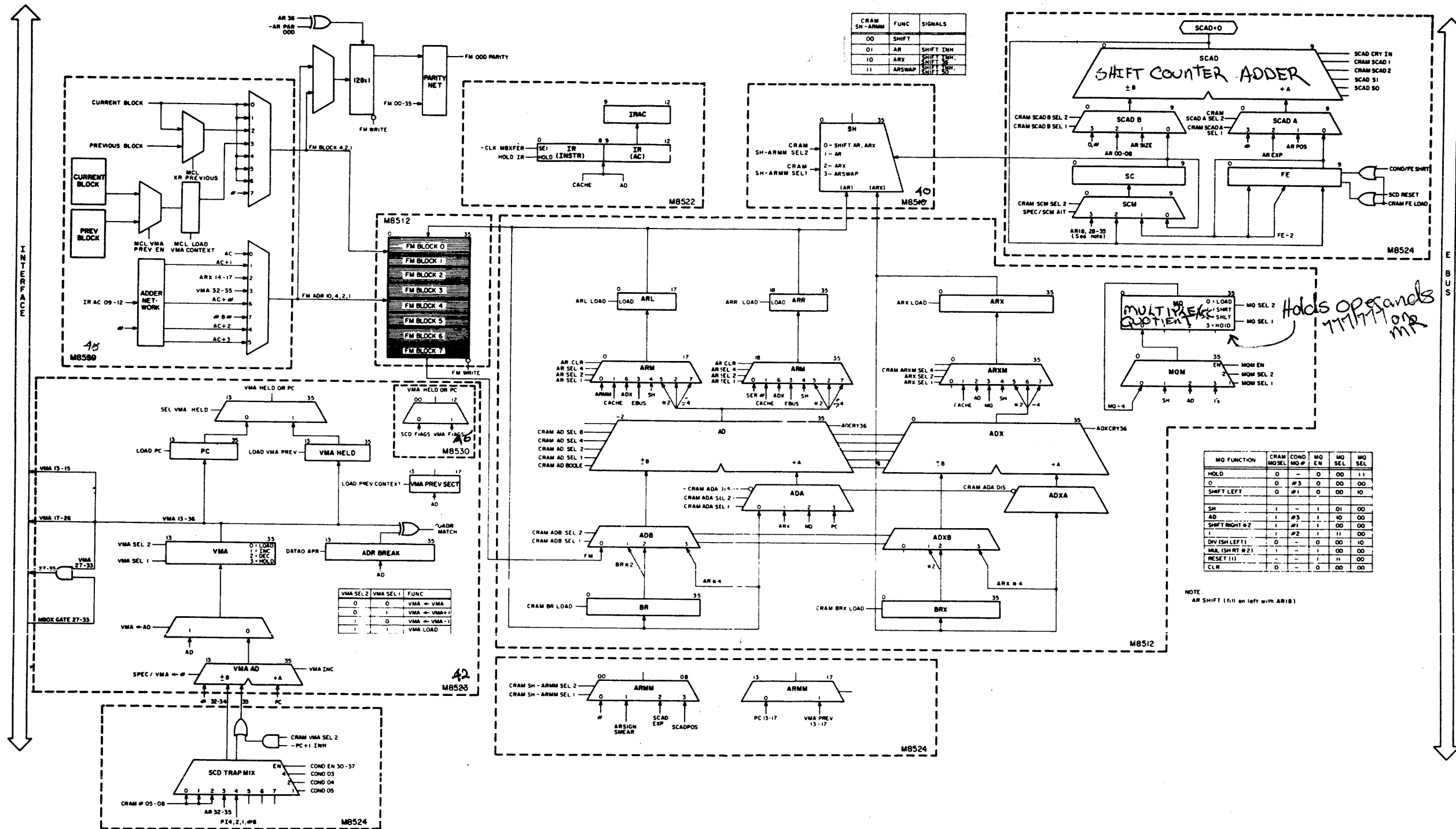

Figure 10 EBox Data and Address Paths

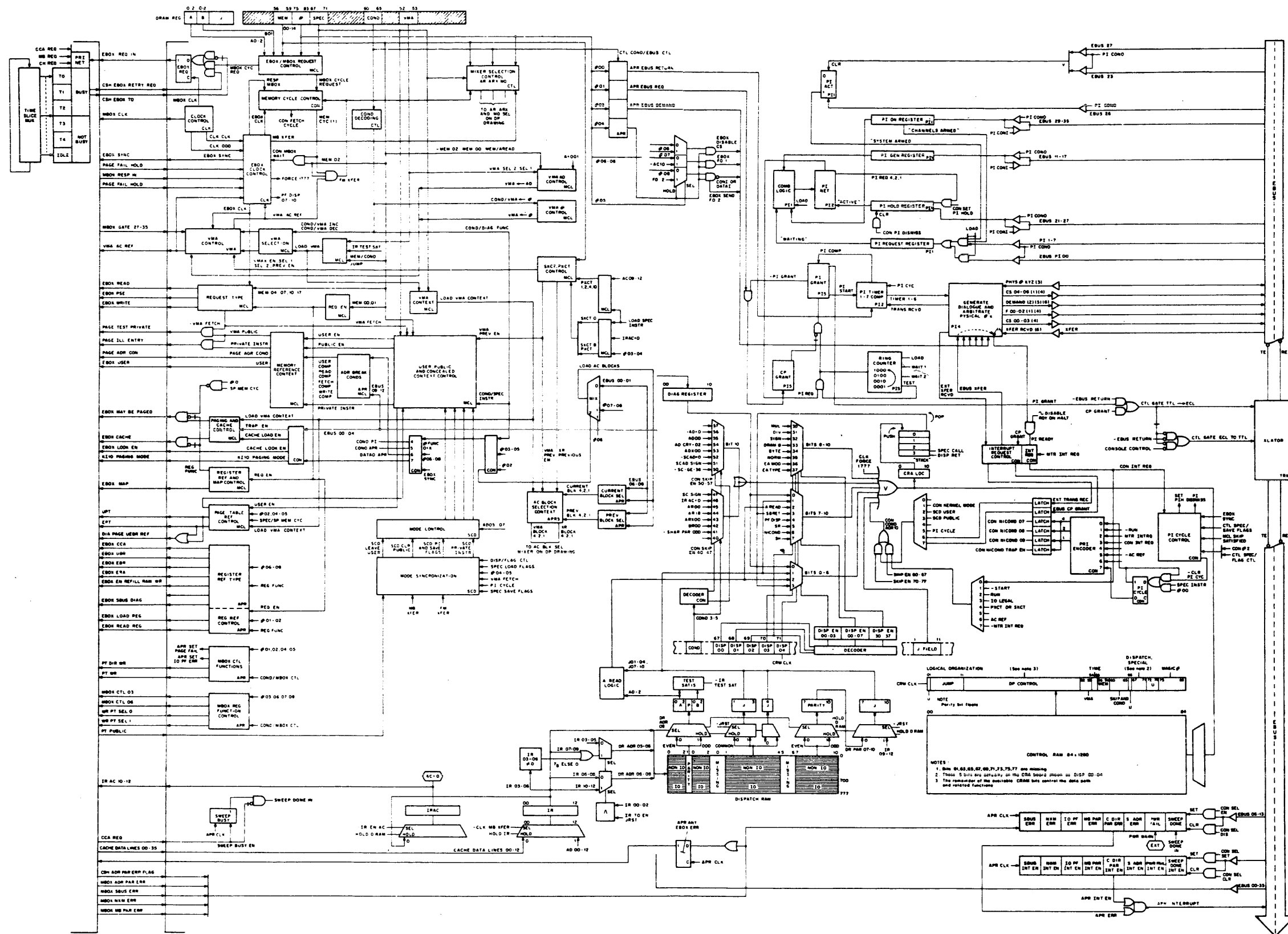

Figure 11 EBox, MBox, and EBus Control Diagram

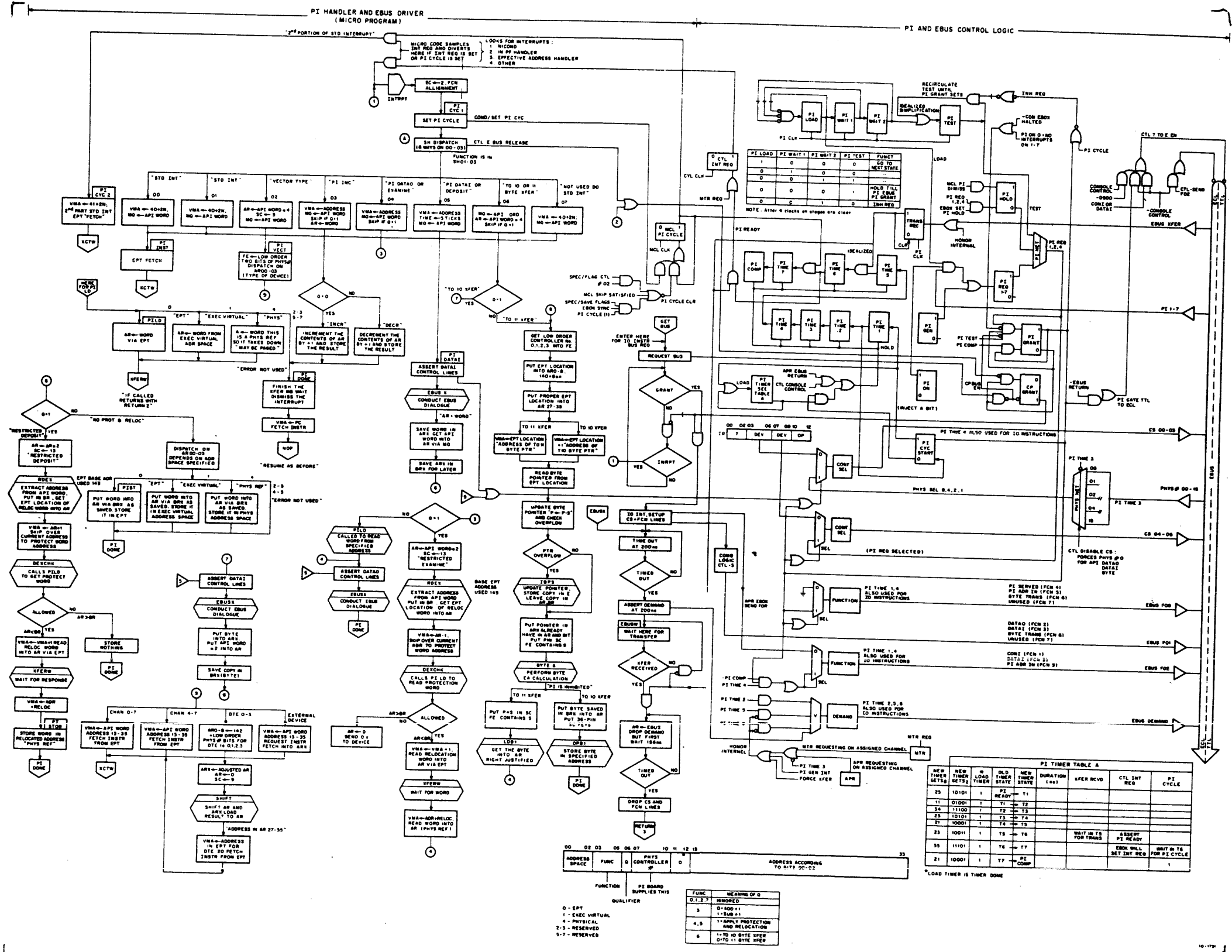

Figure 12 EBus Control, Hybrid Flow Diagram

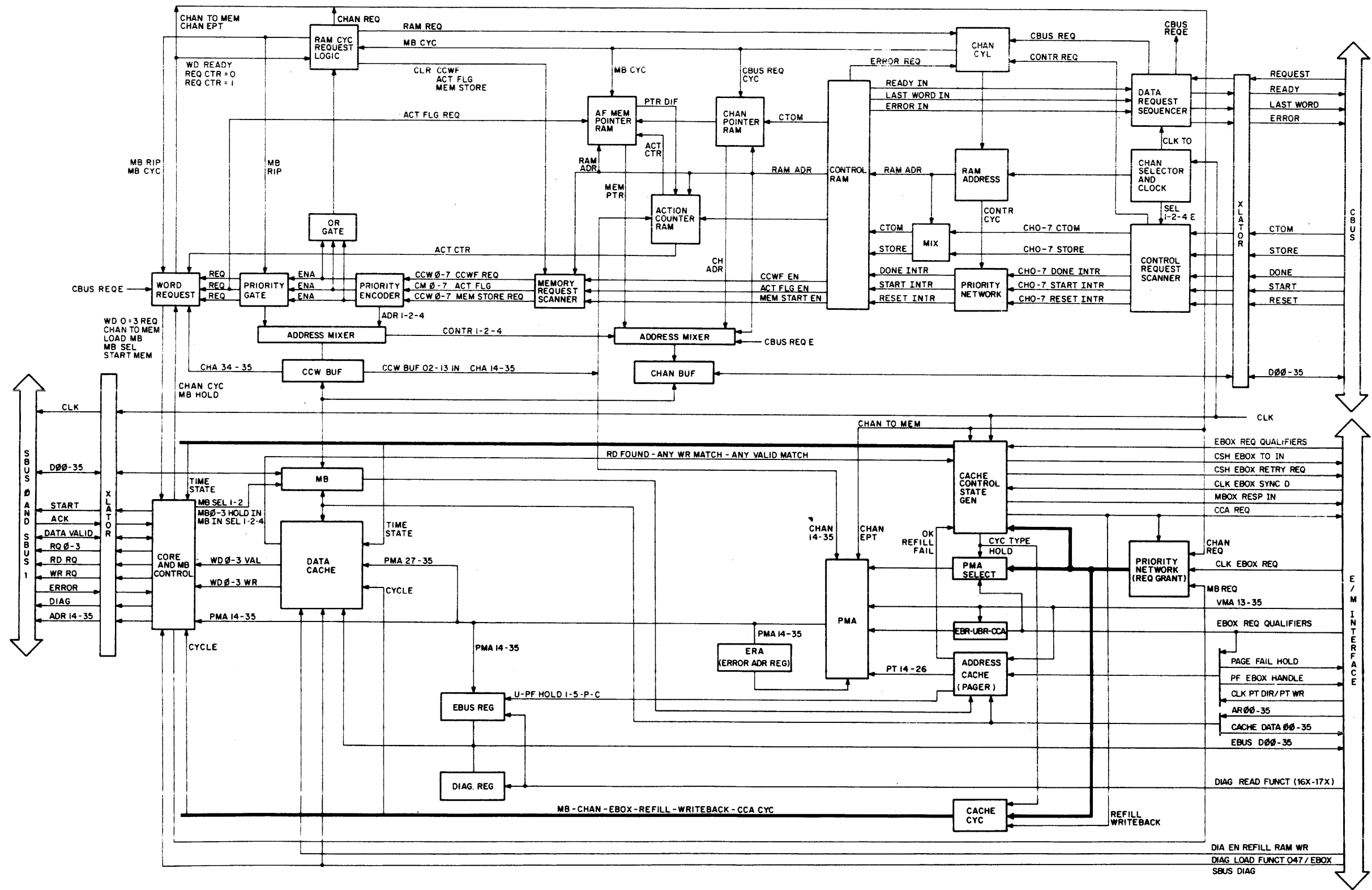
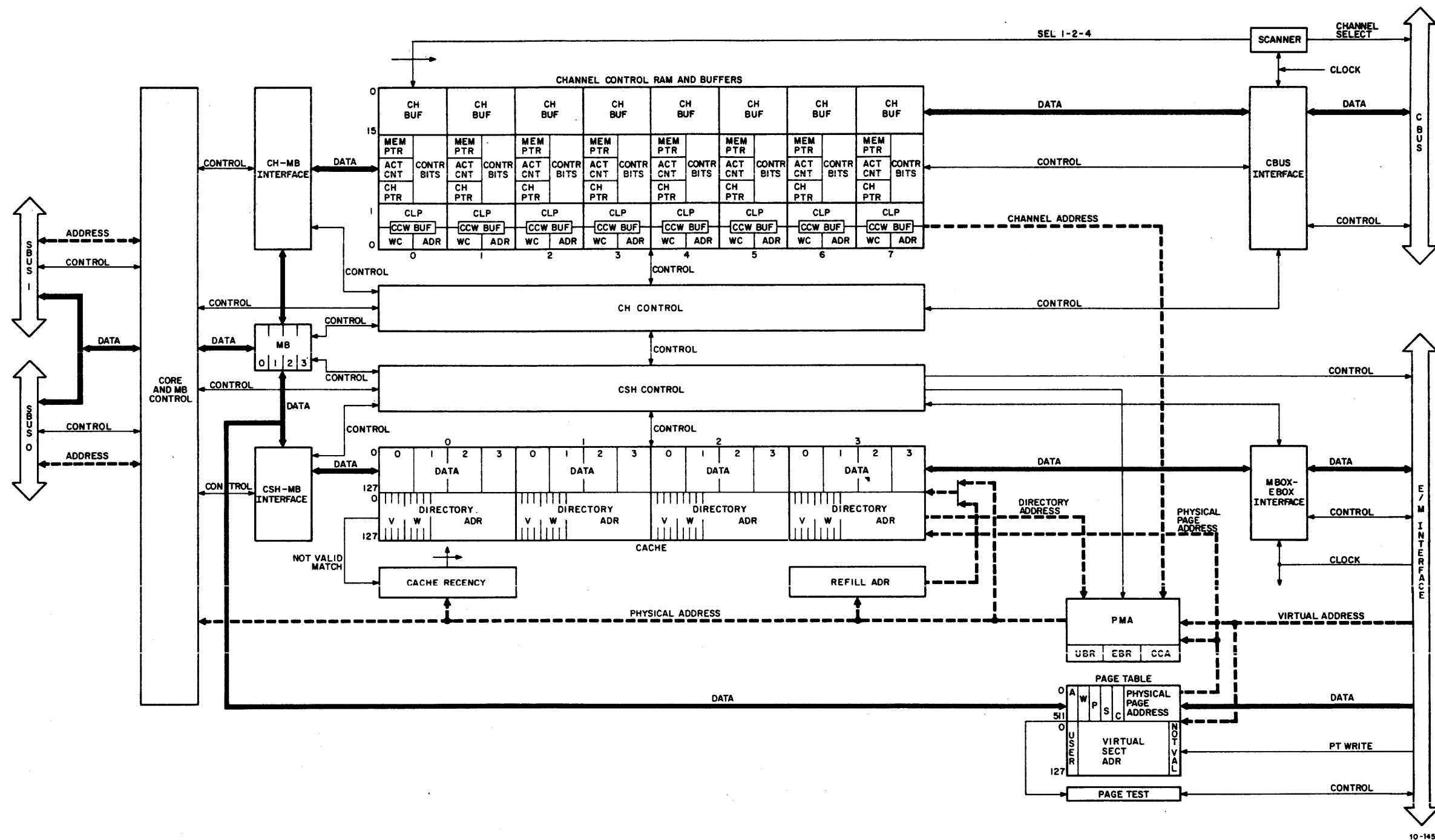

Figure 13 MBox Overall Block Diagram



10-1456

Figure 14 MBox RAM Structures Interfaces and Controls Block Diagram

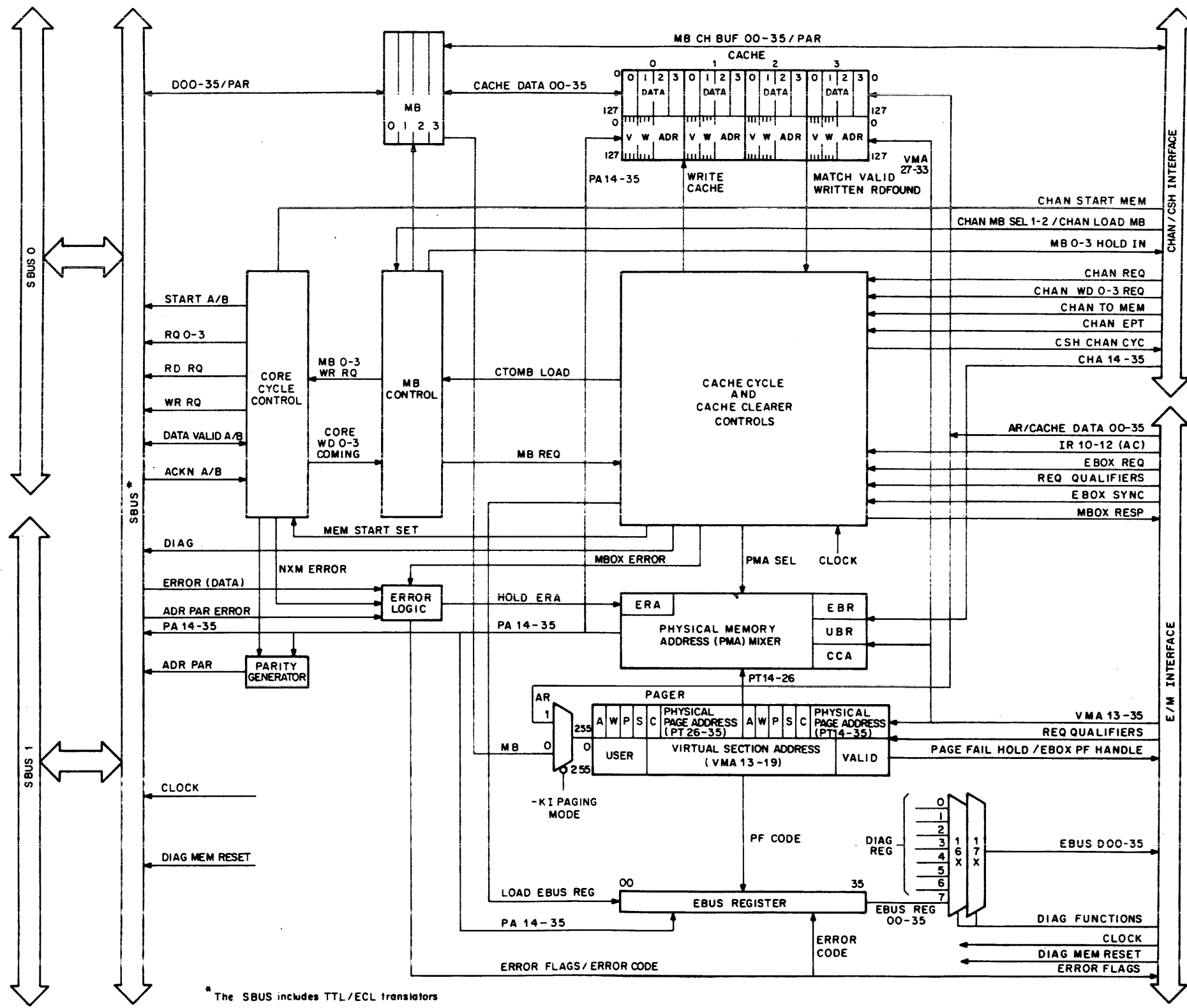
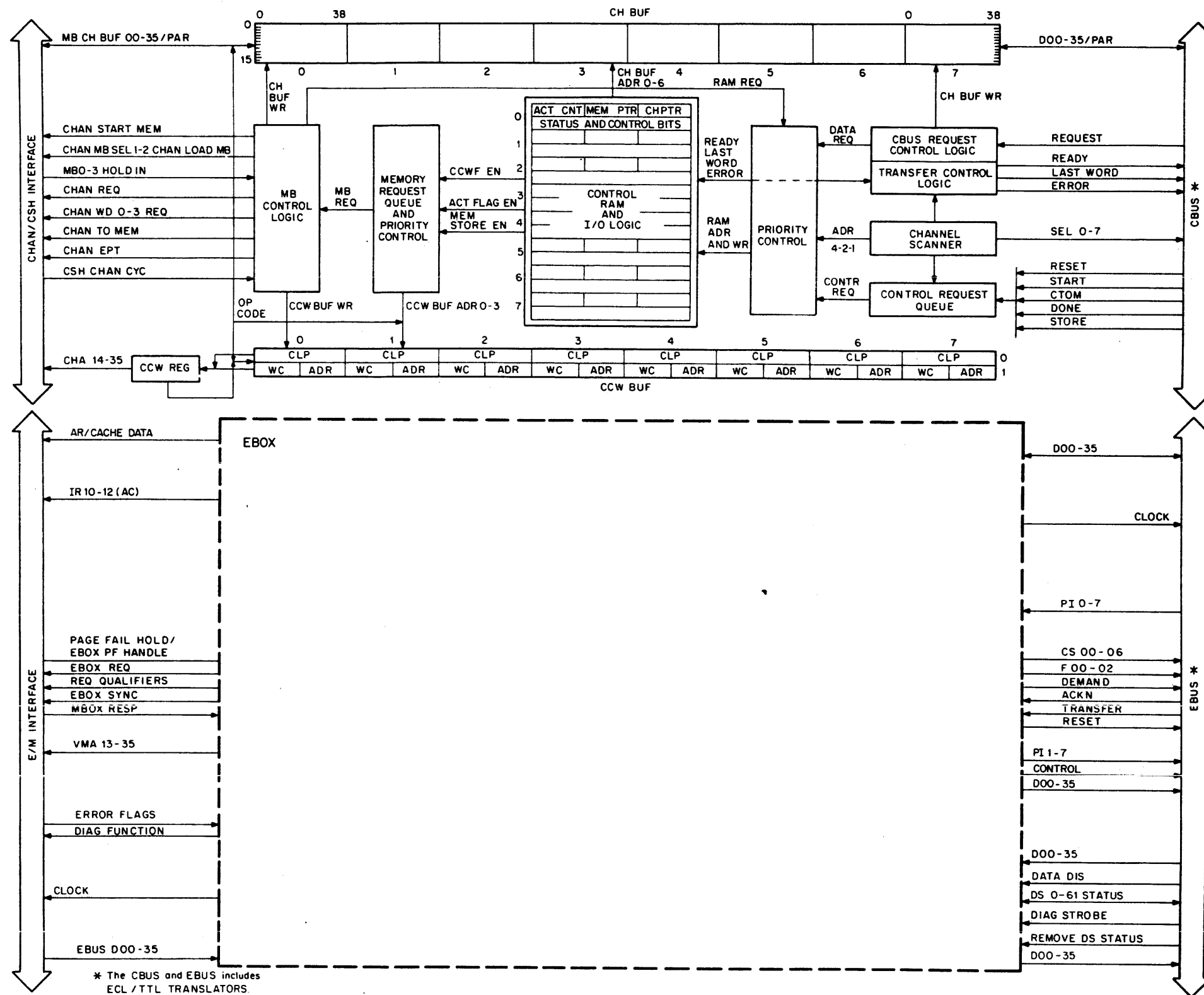

Figure 15 MBox Functional Block Diagram (Sheet 1 of 2)



10-2212

Figure 15 MBox Functional Block Diagram (Sheet 2 of 2)

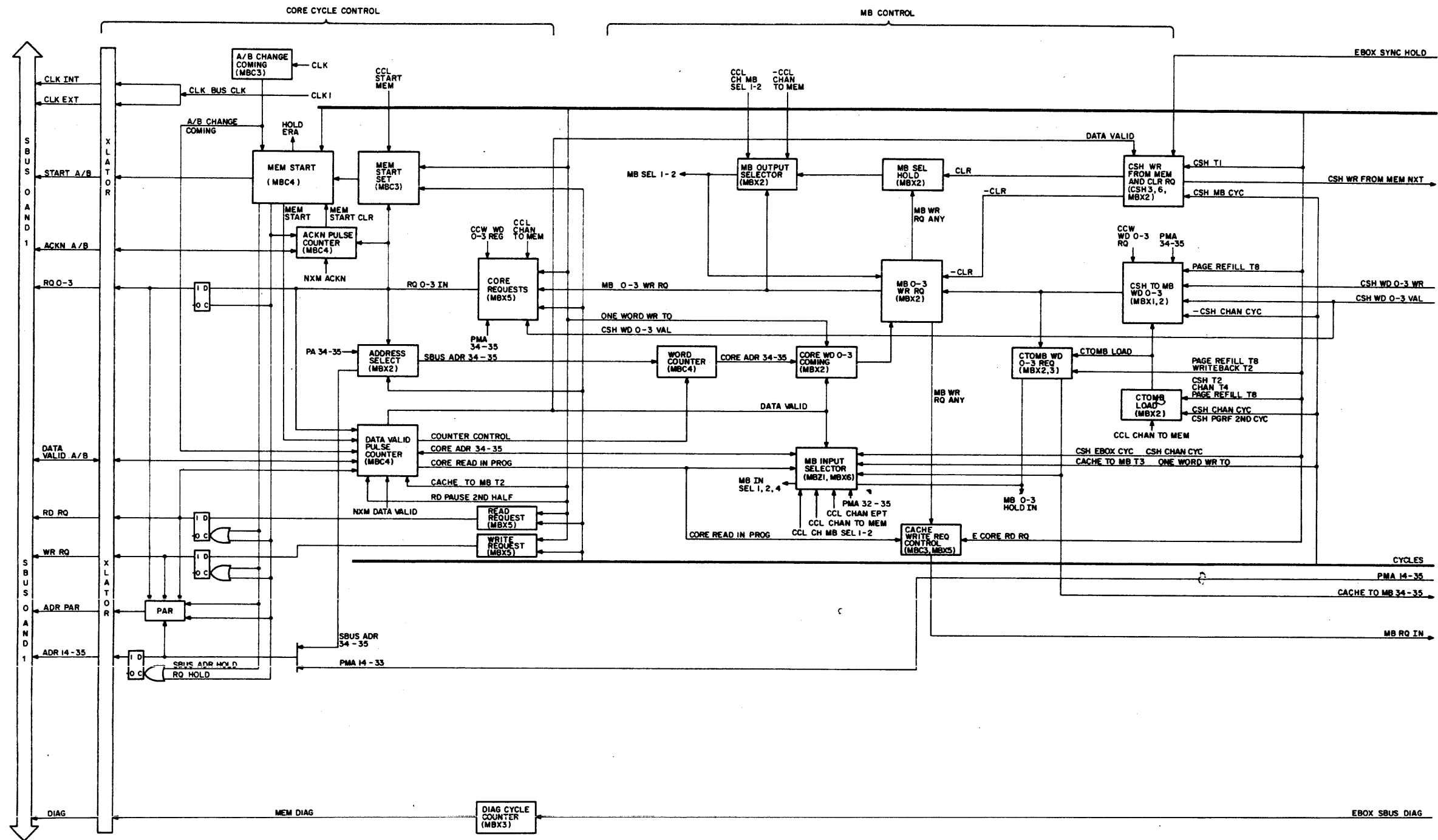

Figure 17 MBox Control Logic Block Diagram (Sheet 1 of 2)

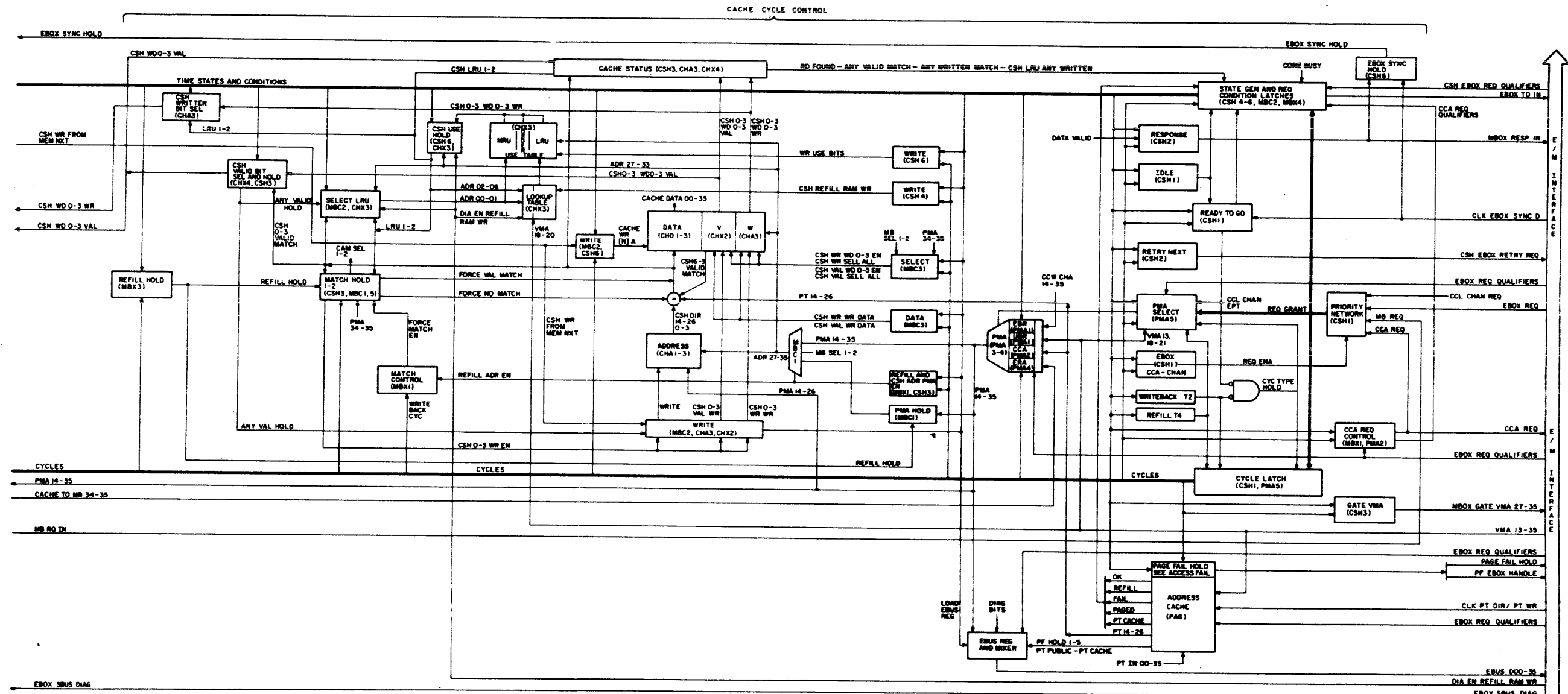
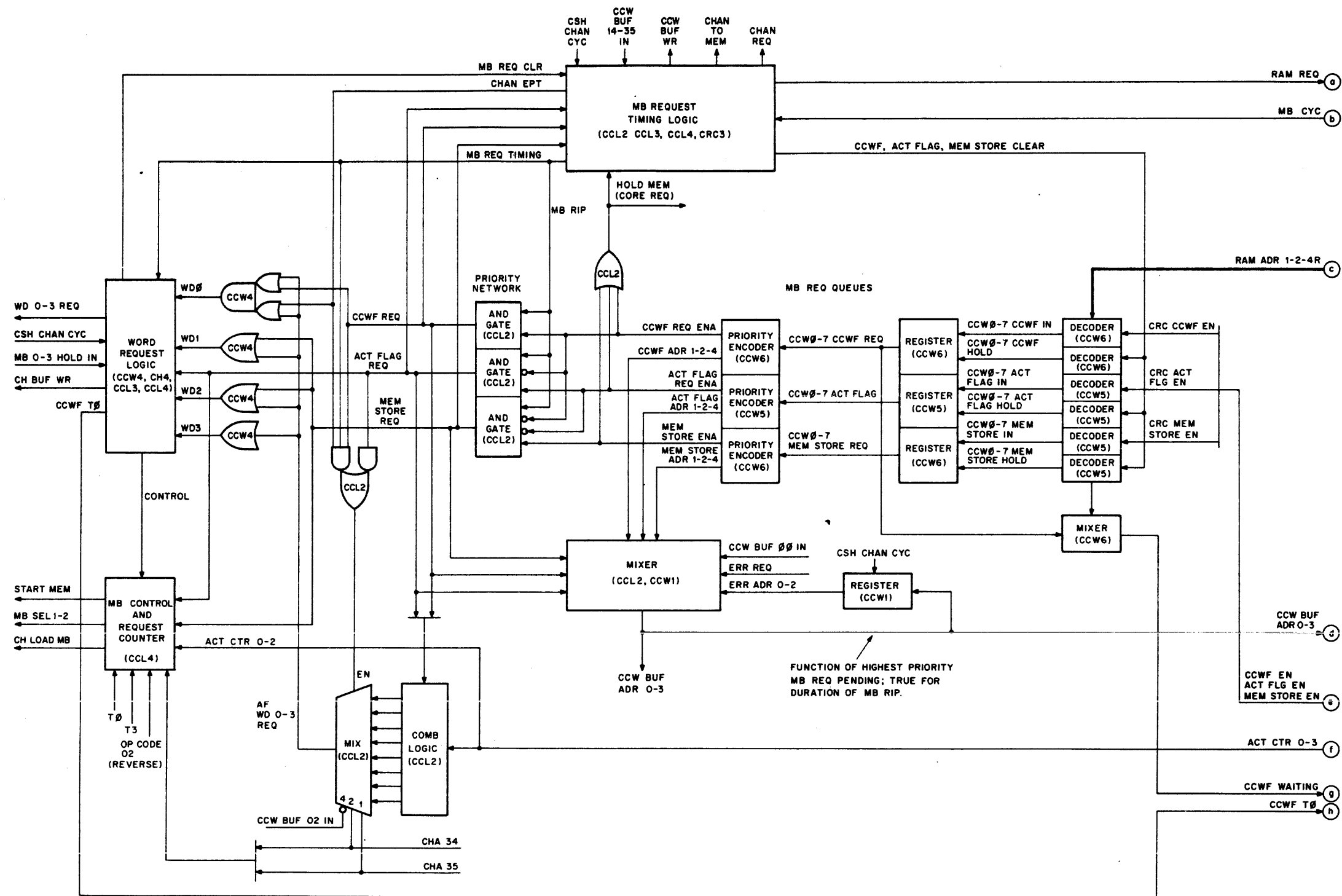

Figure 17 MBox Control Logic Block Diagram (Sheet 2 of 2)



10-2096

Figure 18 MBox Channel Control Logic Block Diagram (Sheet 1 of 3)

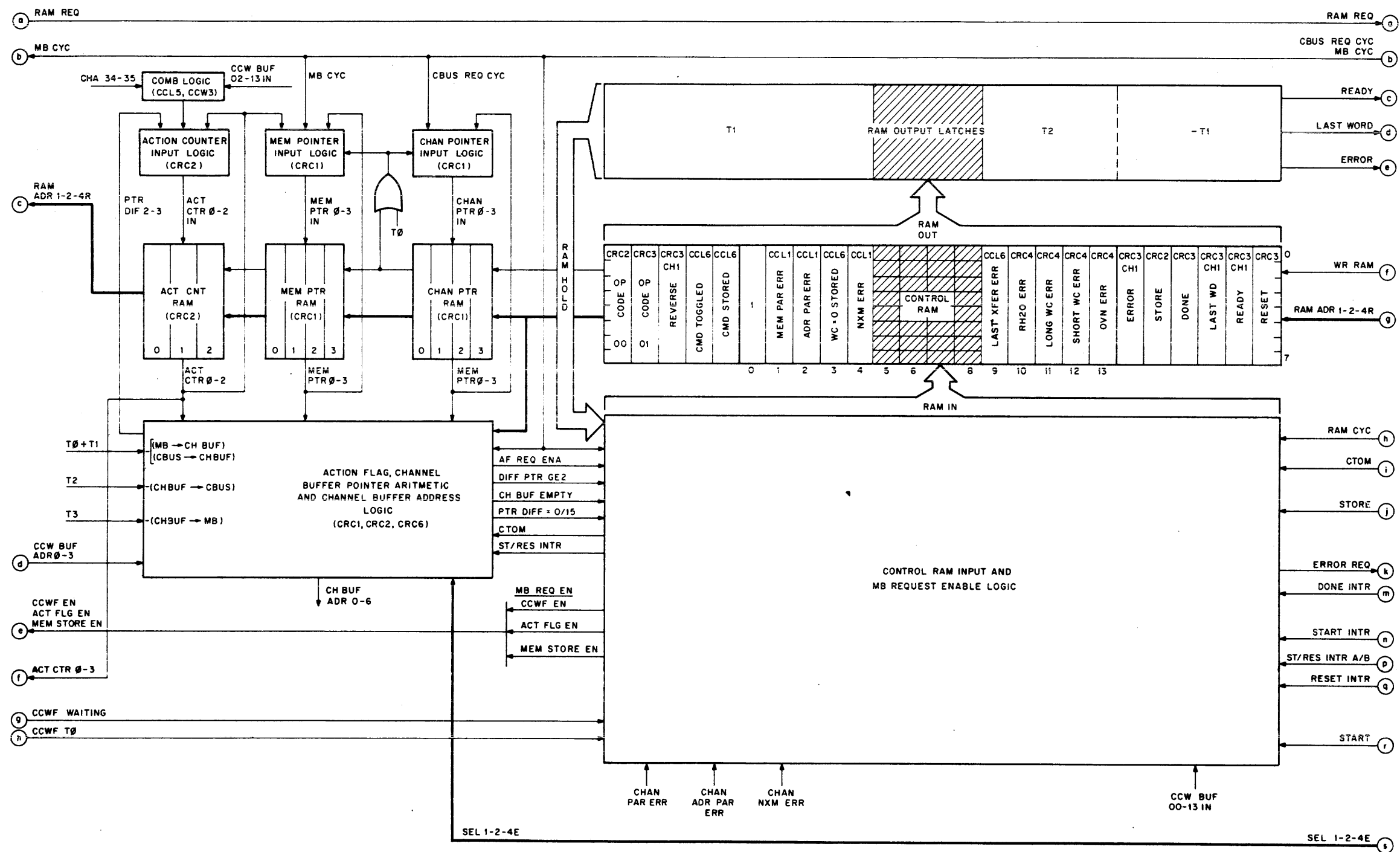
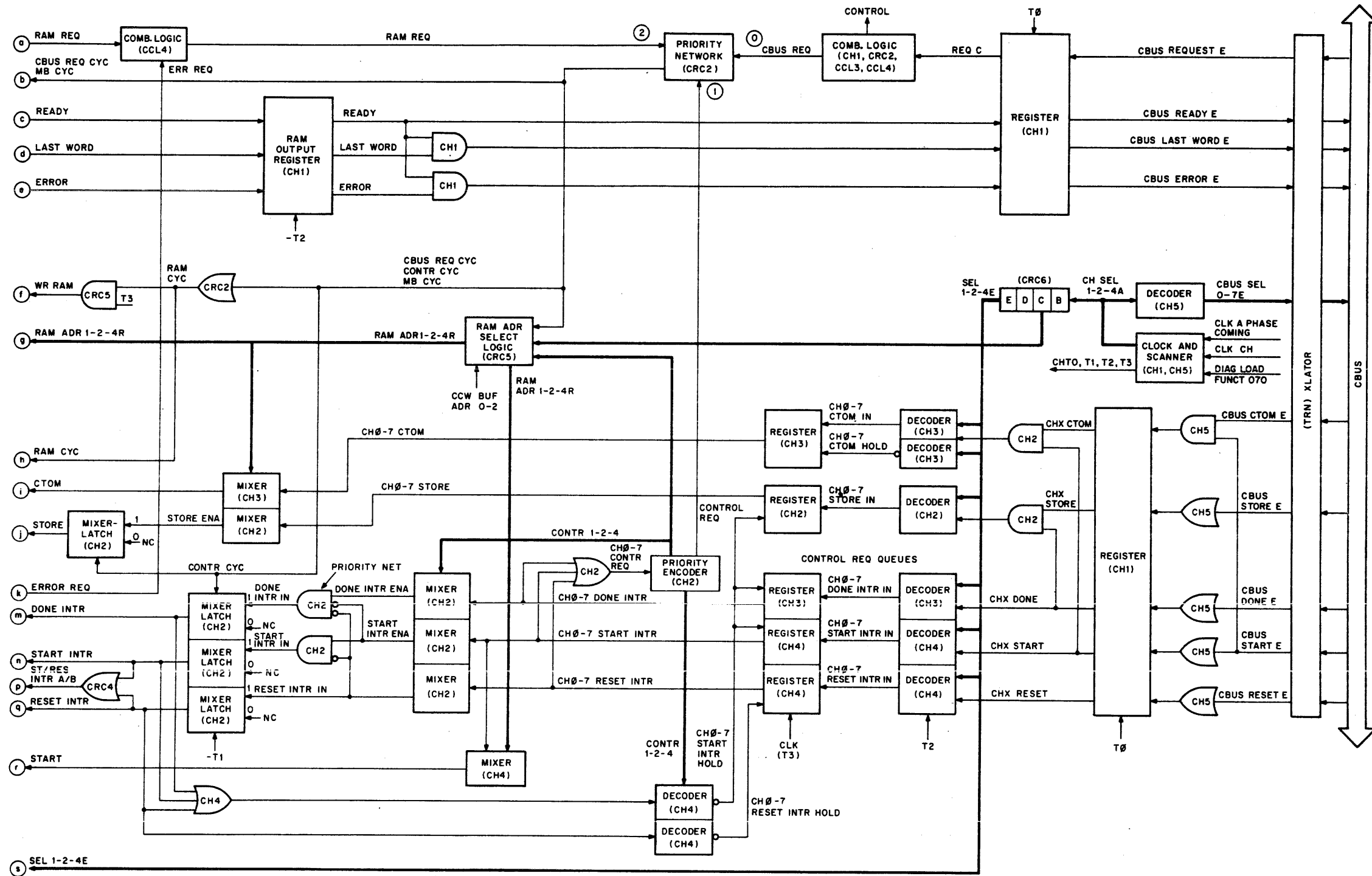

Figure 18 MBox Channel Control Logic Block Diagram (Sheet 2 of 3)



10-2098

Figure 18 MBox Channel Control Logic Block Diagram (Sheet 3 of 3)

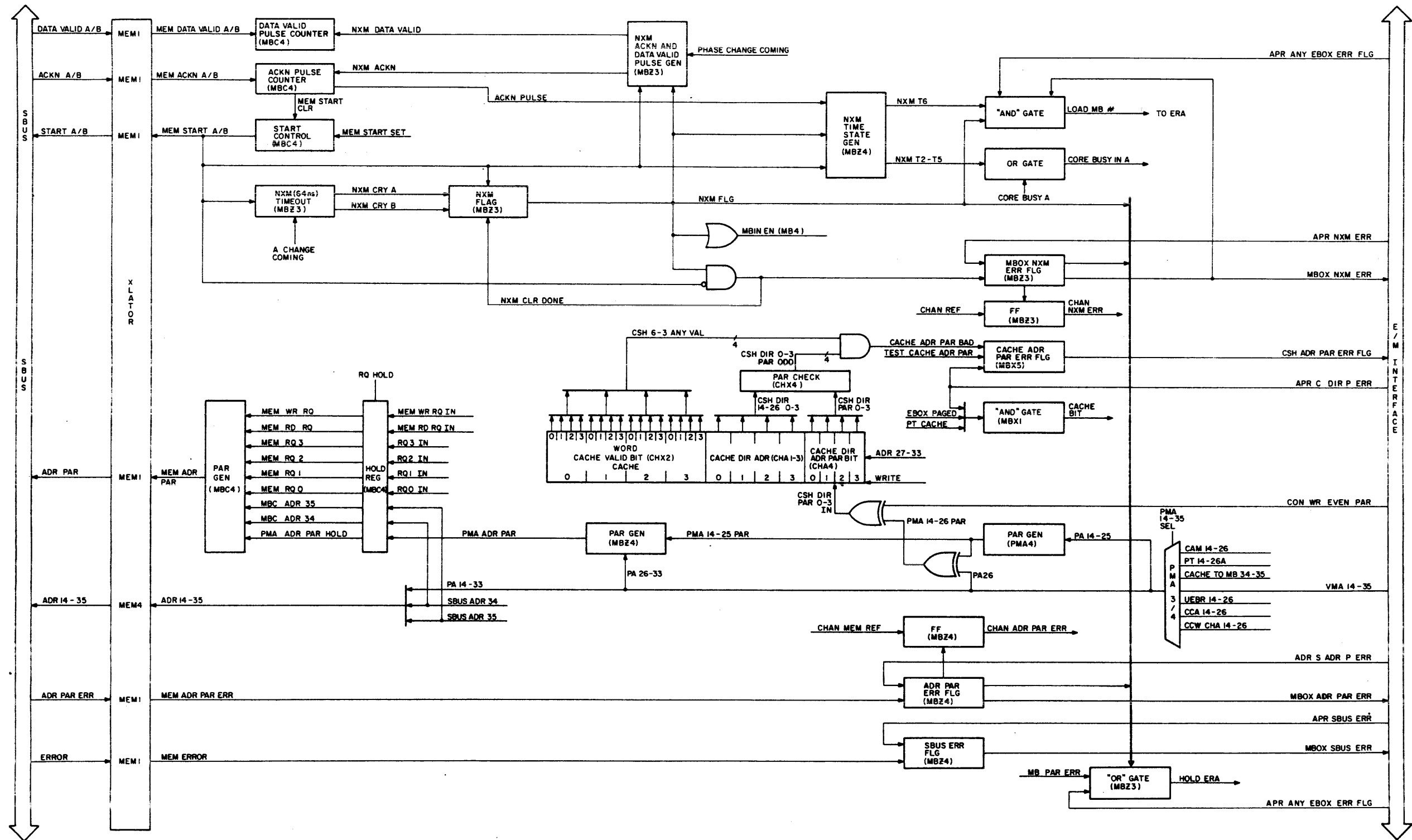
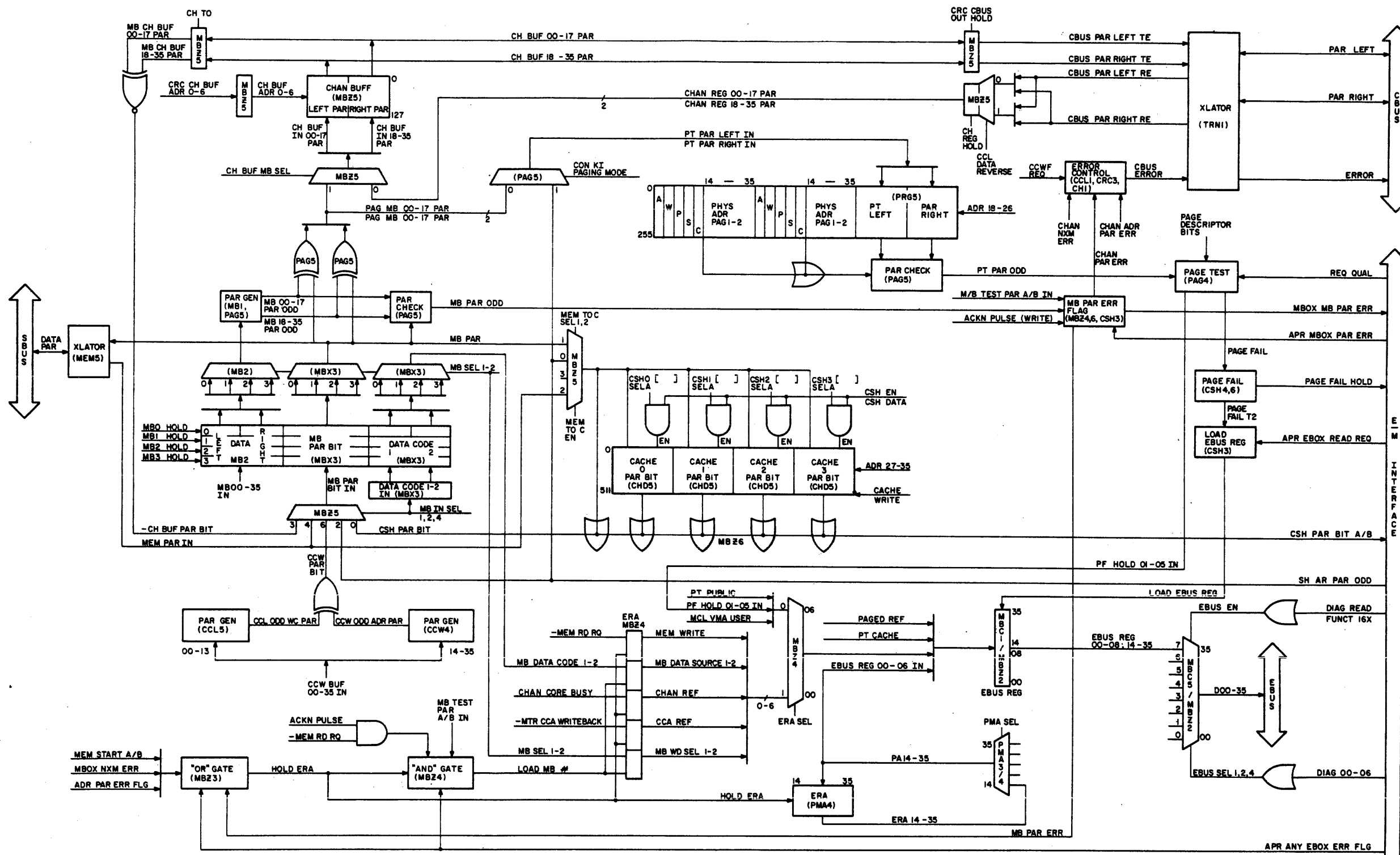

Figure 19 MBox Address Parity, NXM and SBus Error, Path Diagram



10-1488

Figure 20 MBox Data and Page Table, Path Diagram

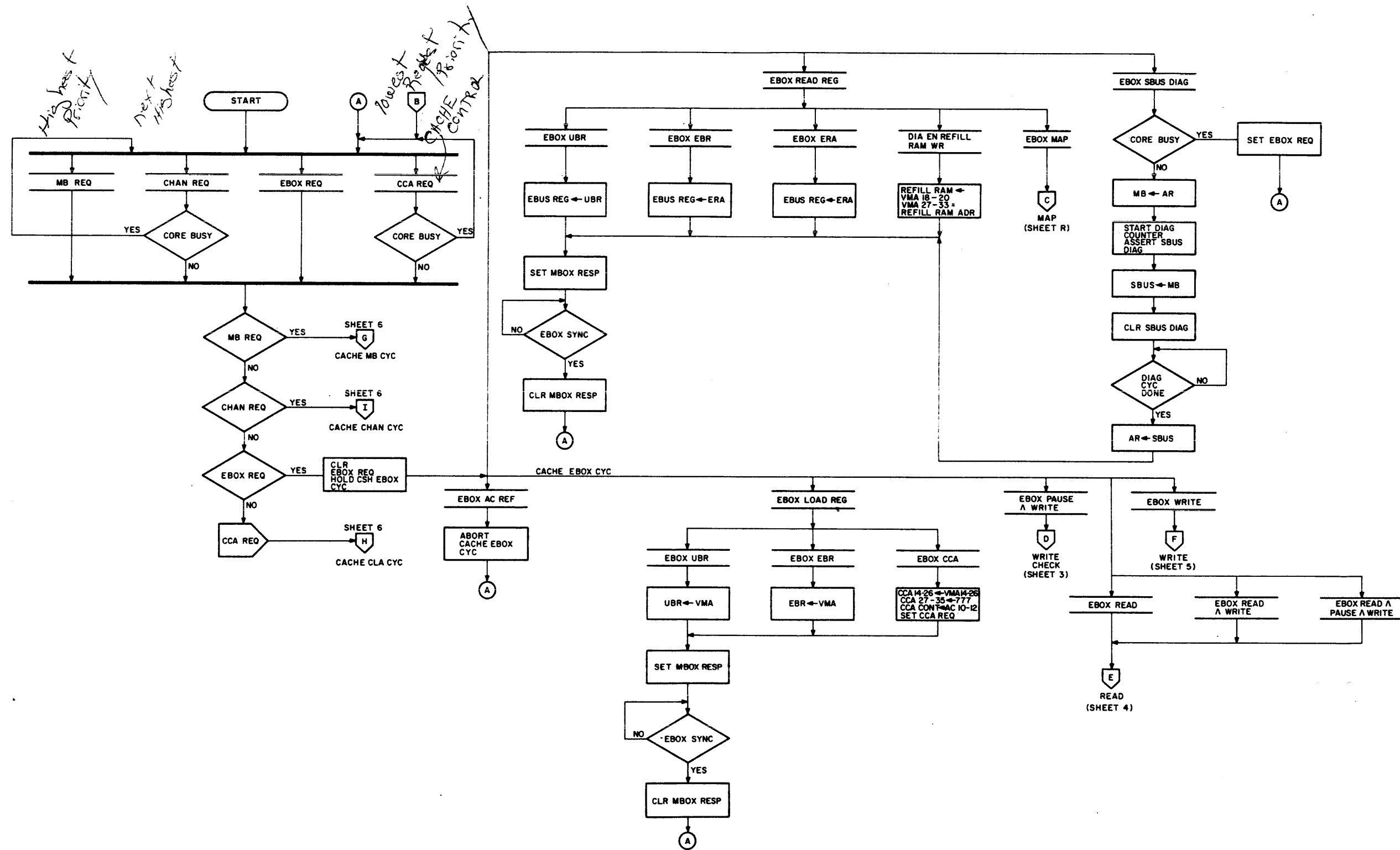
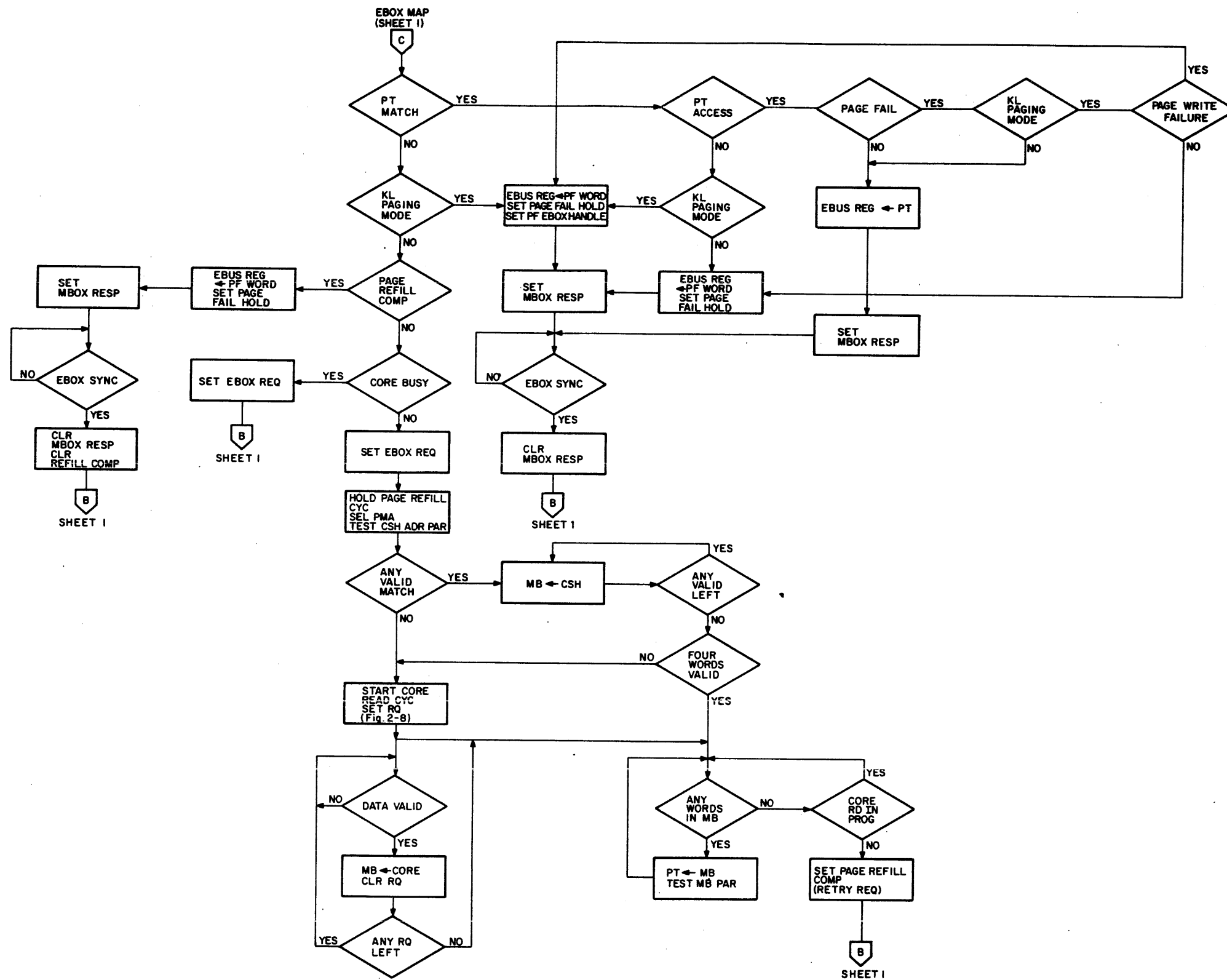
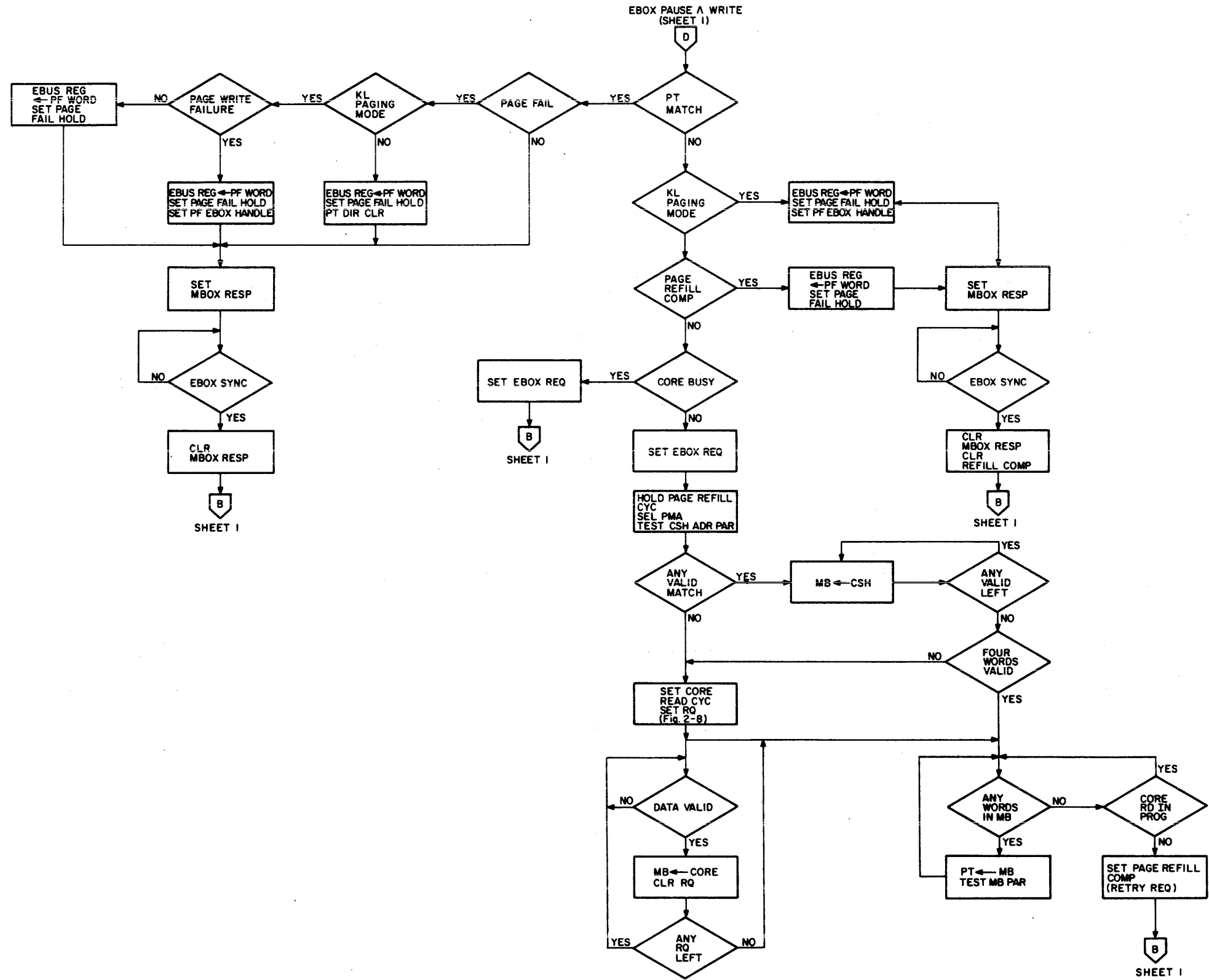

Figure 21 MBox Cache Cycle Control Functional Flow Diagram (Sheet 1 of 6)



10-1477

Figure 21 MBox Cache Cycle Control Functional Flow Diagram (Sheet 2 of 6)



10-1478

Figure 21 MBox Cache Cycle Control Functional Flow Diagram (Sheet 3 of 6)

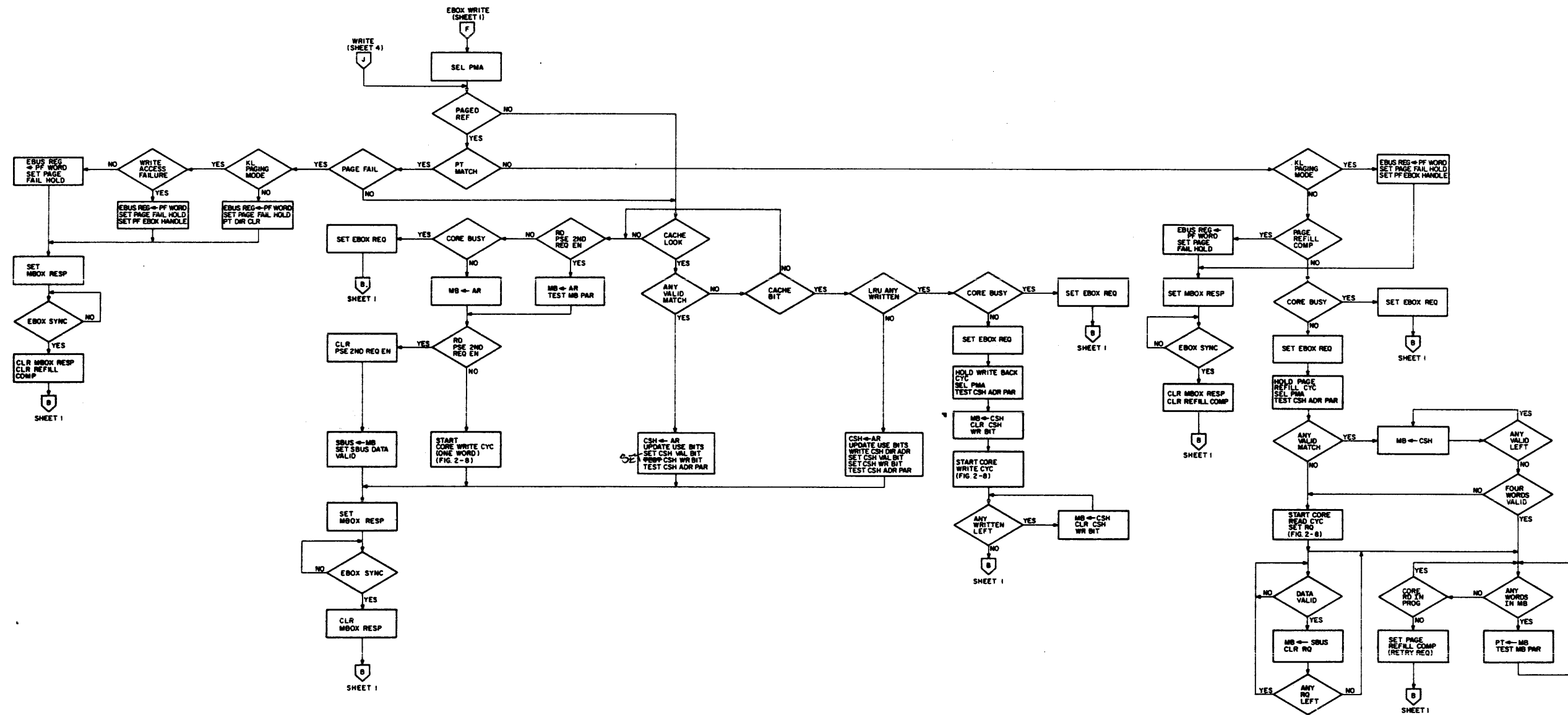
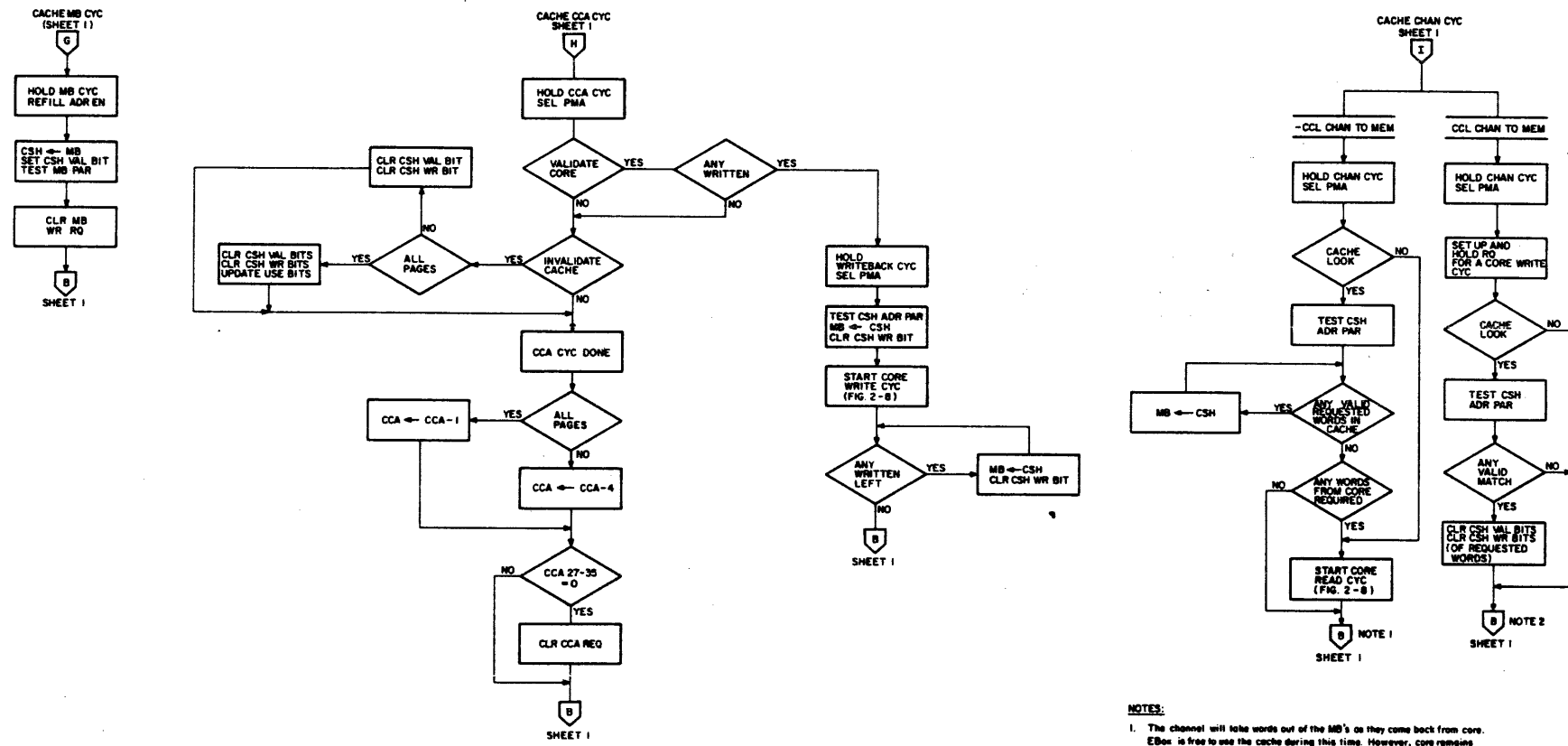

Figure 21 MBox Cache Cycle Control Functional Flow Diagram (Sheet 5 of 6)



NOTES:

1. The channel will take words out of the MB's as they come back from core. EBox is free to use the cache during this time. However, core remains busy and prevents the EBox from getting a core cycle.
2. The channel takes control at this point. The channel loads a word into the MB's and starts a core write cycle. The channel then loads any remaining words into the MB's. EBox is free to use the cache during this time. However, Core remains busy and prevents the EBox from getting a core cycle.

10-1481

Figure 21 MBox Cache Cycle Control Functional Flow Diagram (Sheet 6 of 6)

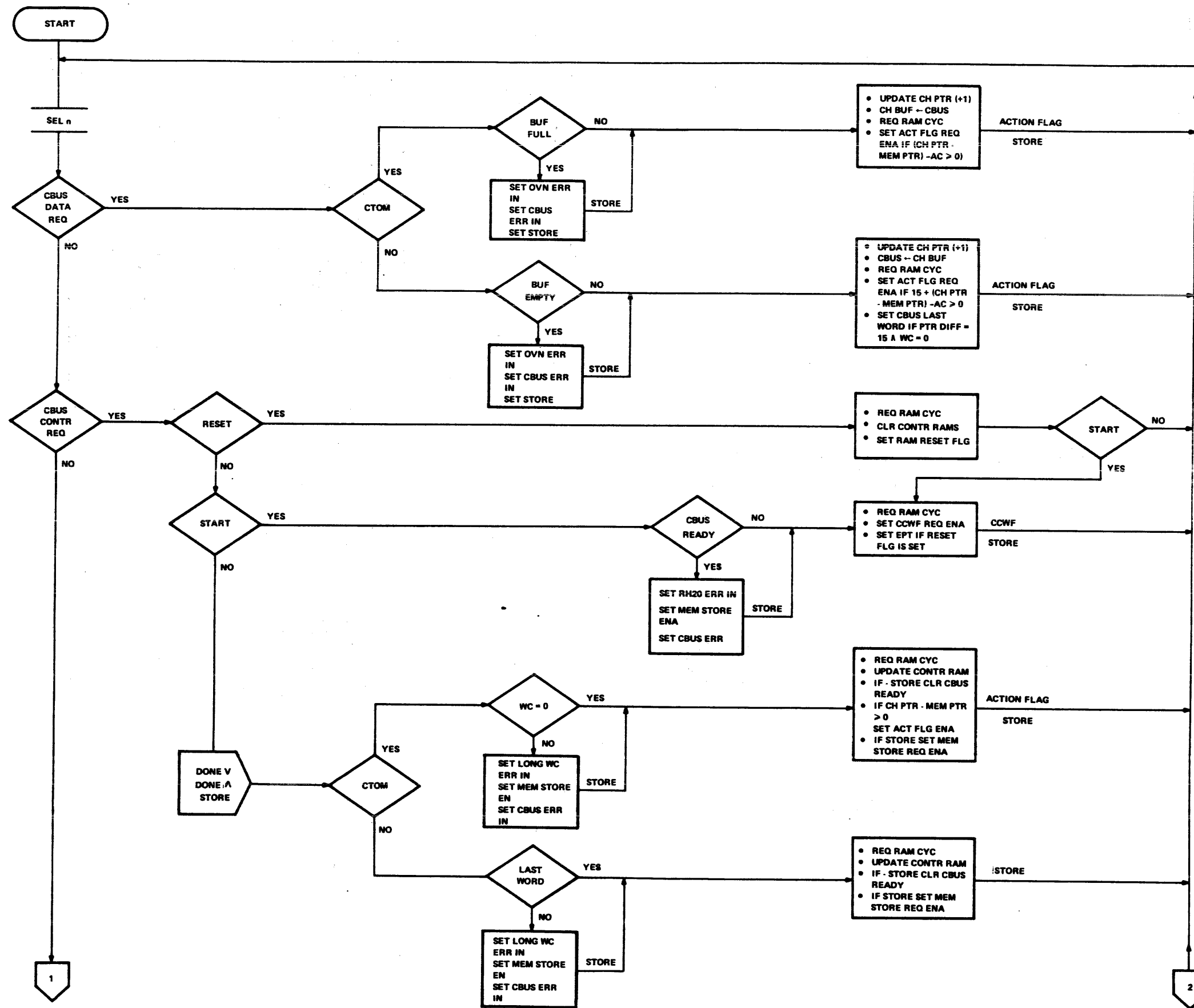
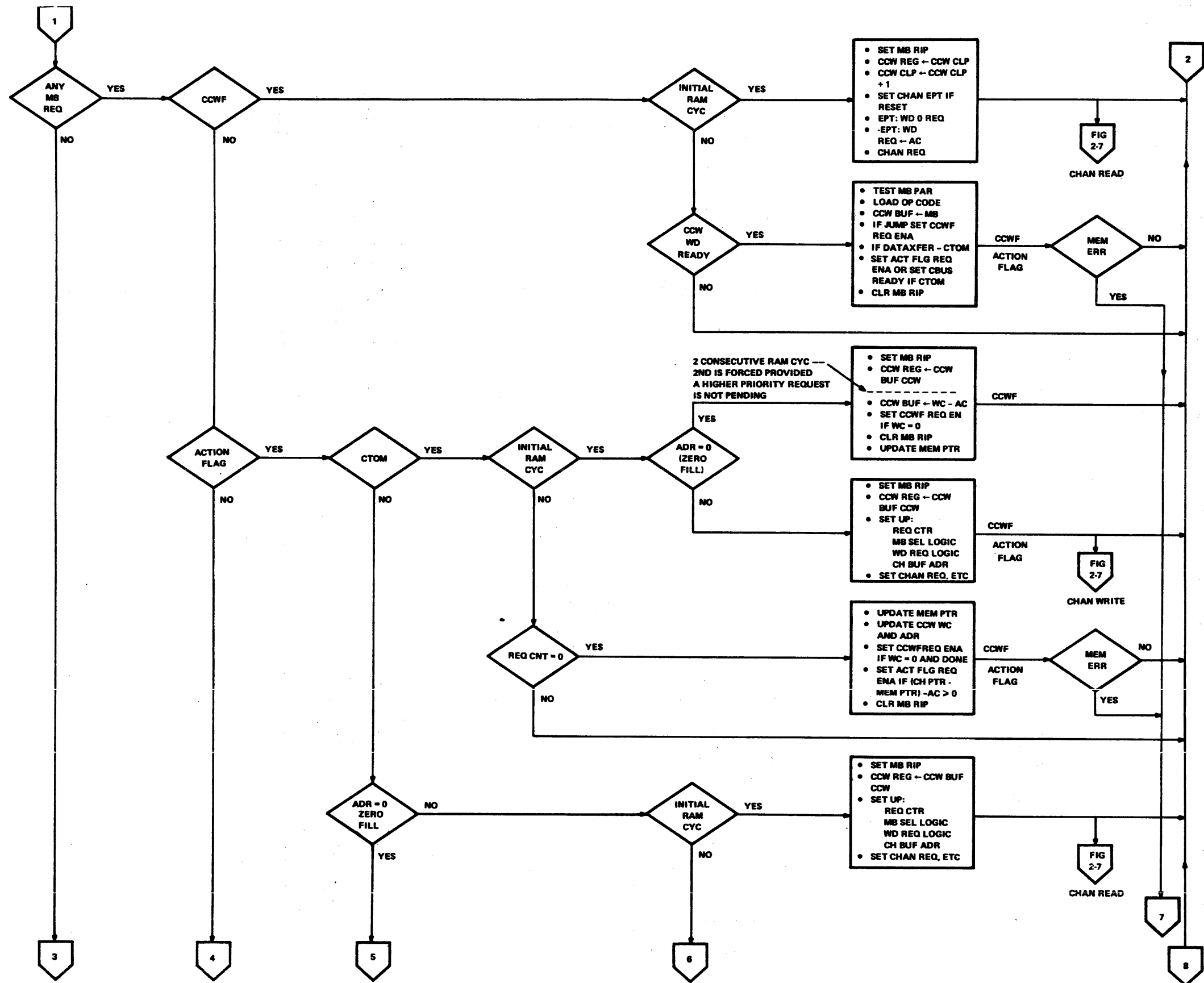
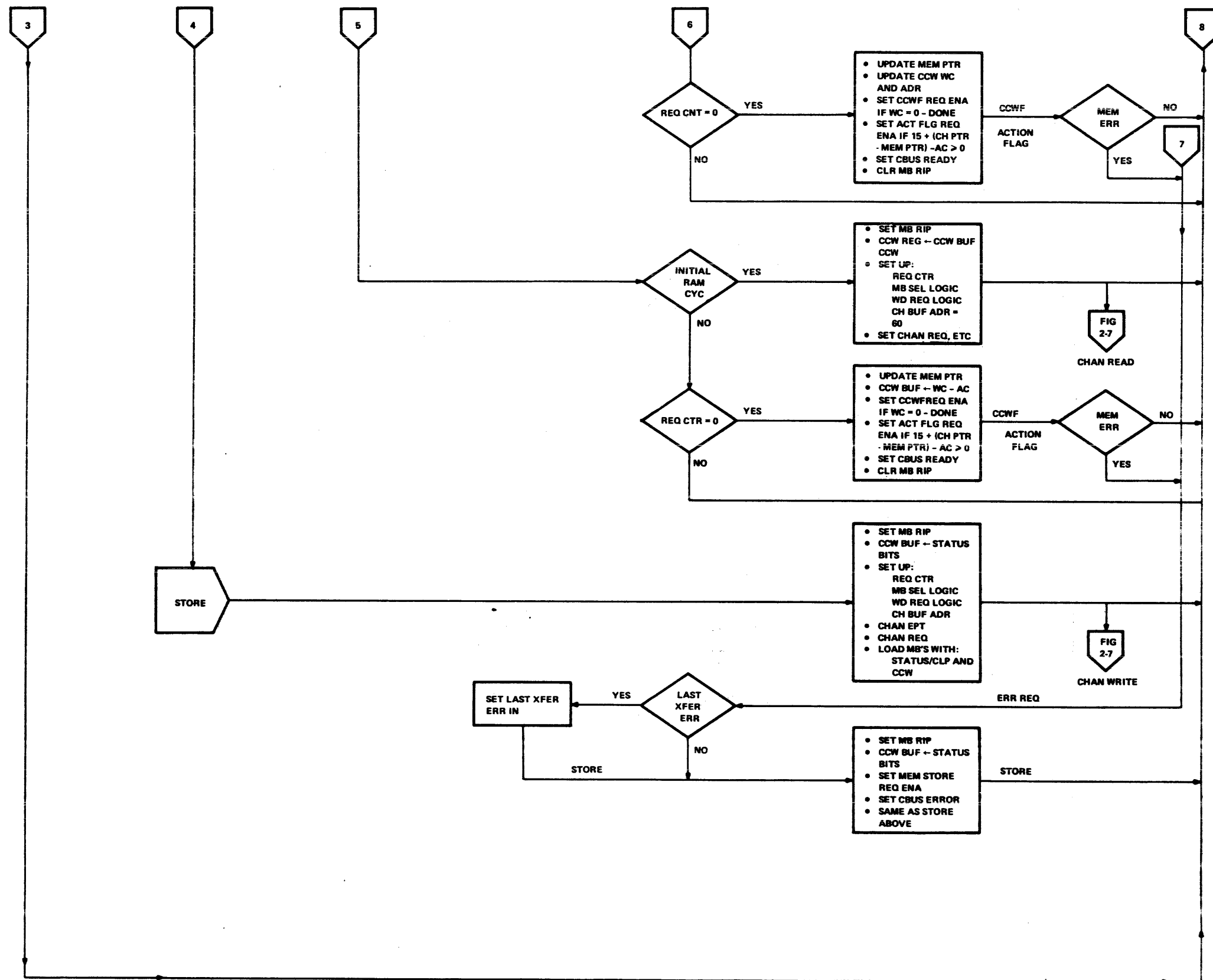

Figure 22 MBox Channel RAM Cycle Control Functional Flow Diagram (Sheet 1 of 3)



10-2103

Figure 22 MBox Channel RAM Cycle Control Functional Flow Diagram (Sheet 2 of 3)



10-2104

Figure 22 MBox Channel RAM Cycle Control Functional Flow Diagram (Sheet 3 of 3)

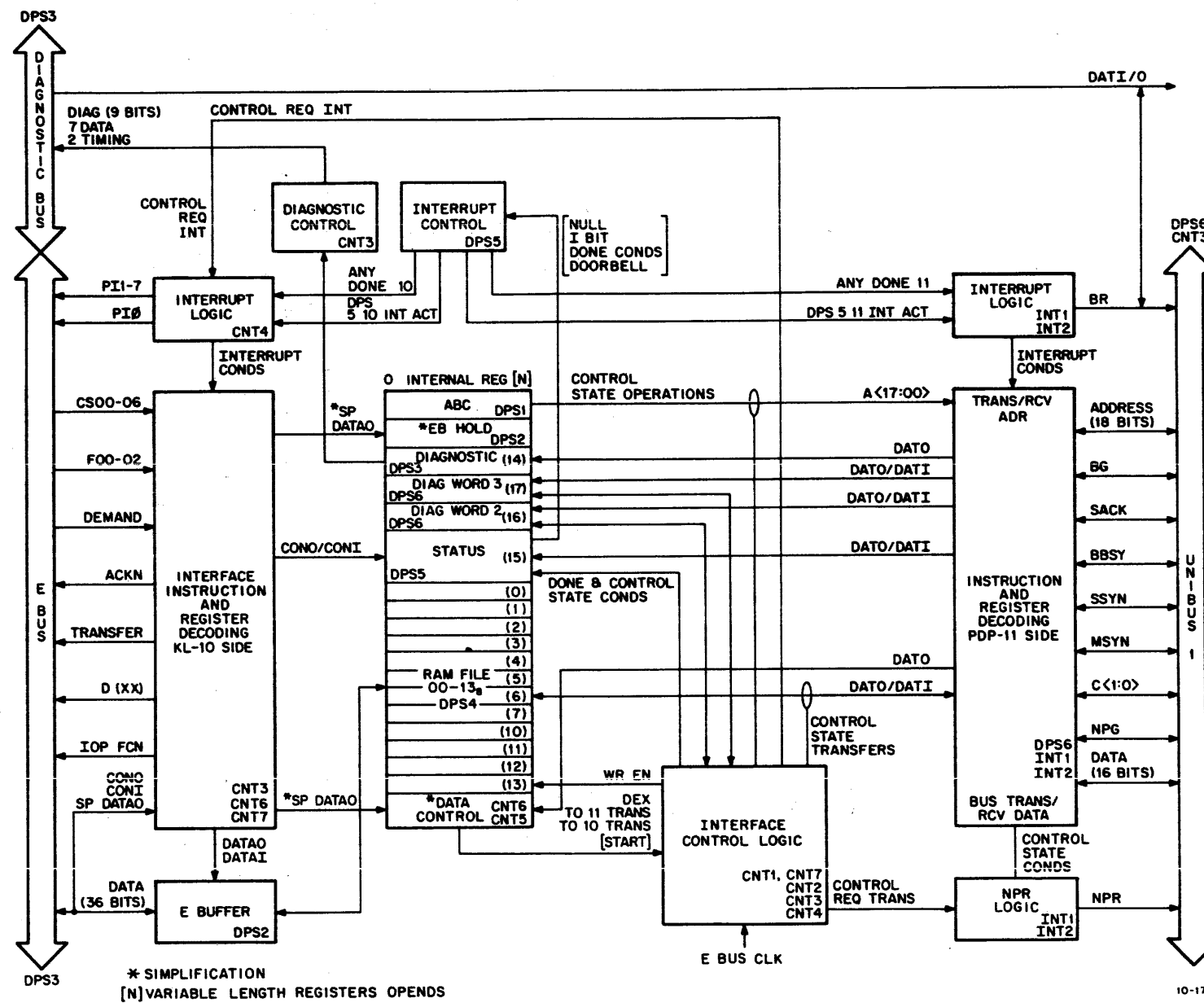
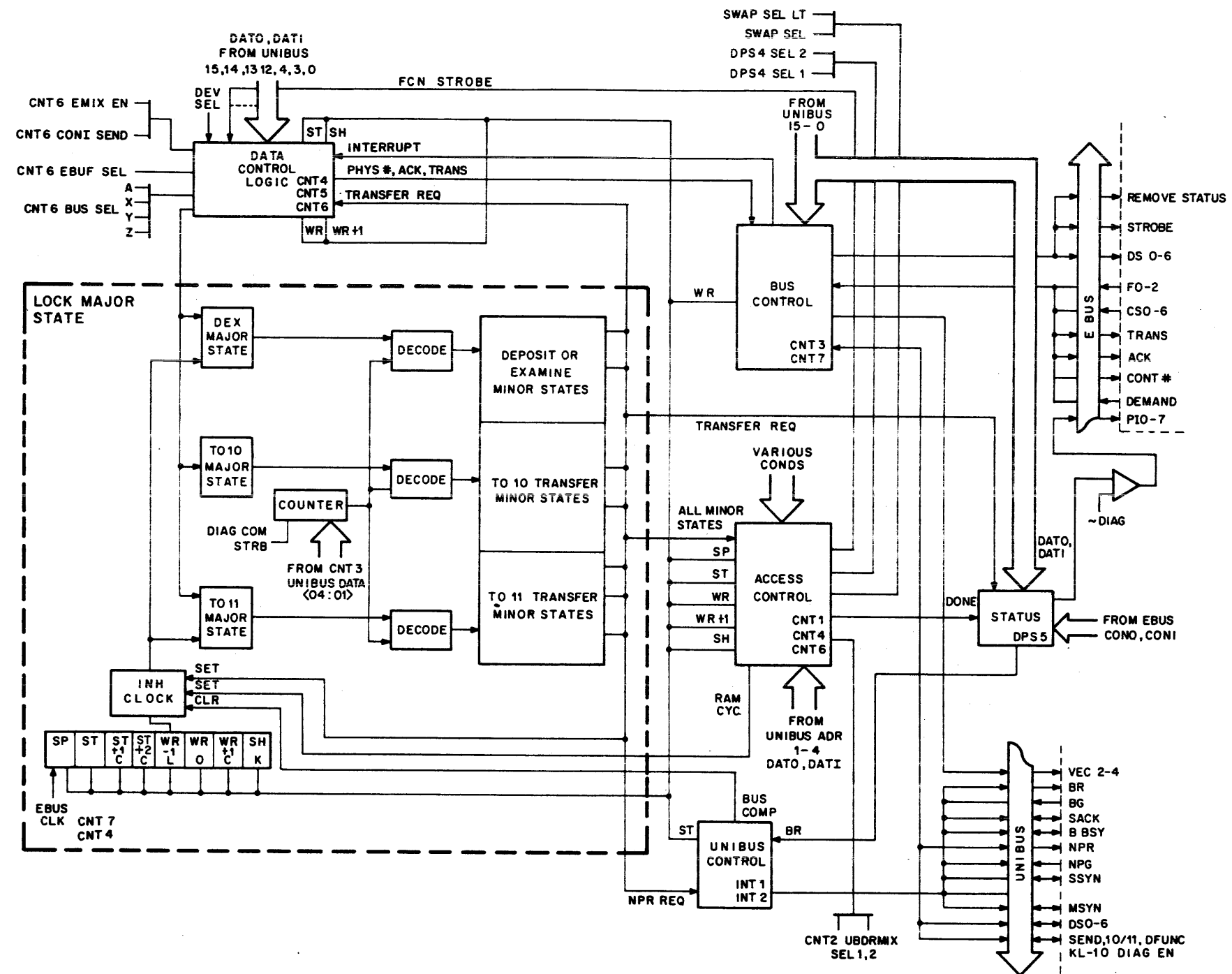

Figure 23 DTE Simplified Functional Block Diagram



10-1800

Figure 24 DTE Simplified Control Block Diagram

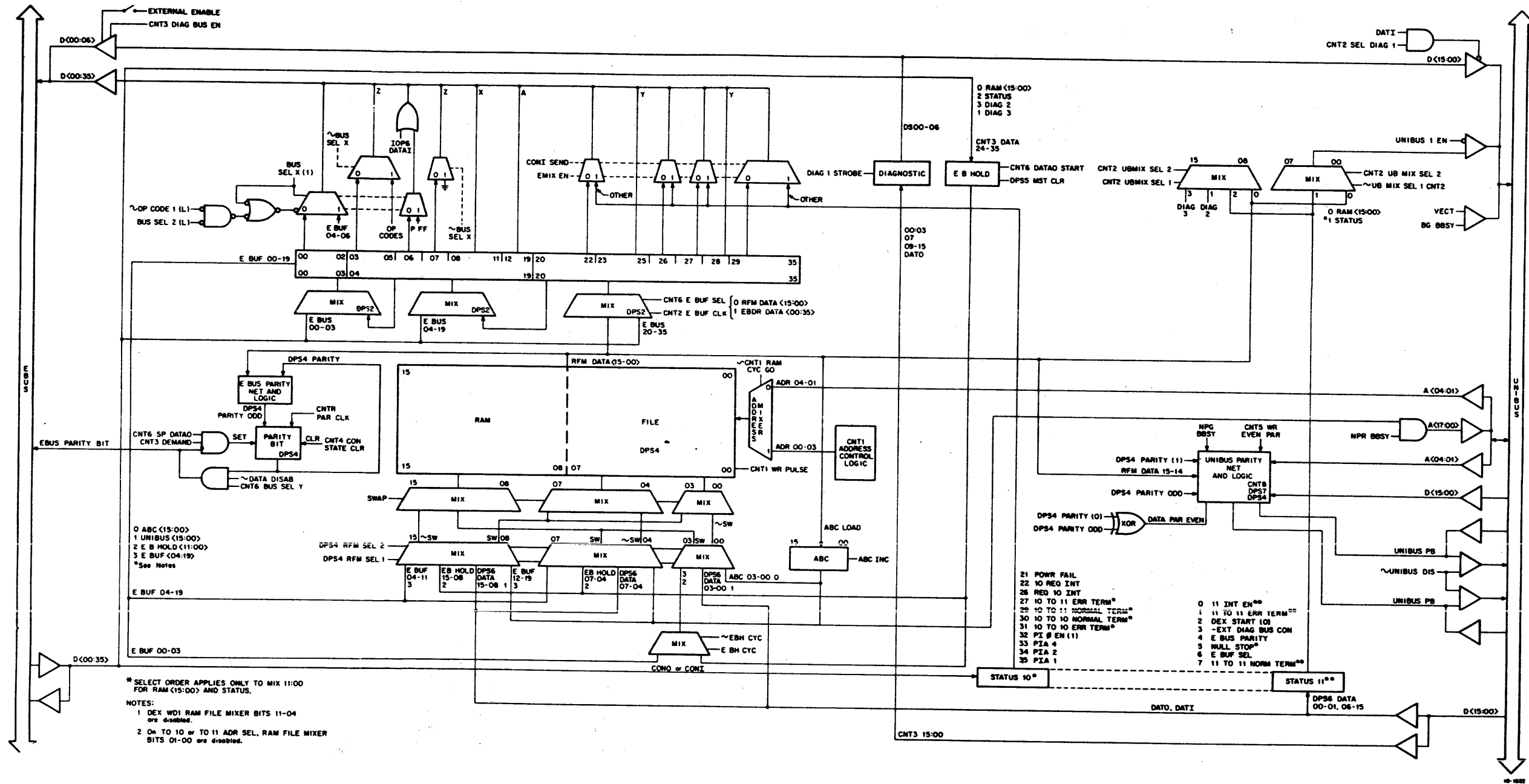

Figure 25 DTE20 Address and Data Paths Block Diagram

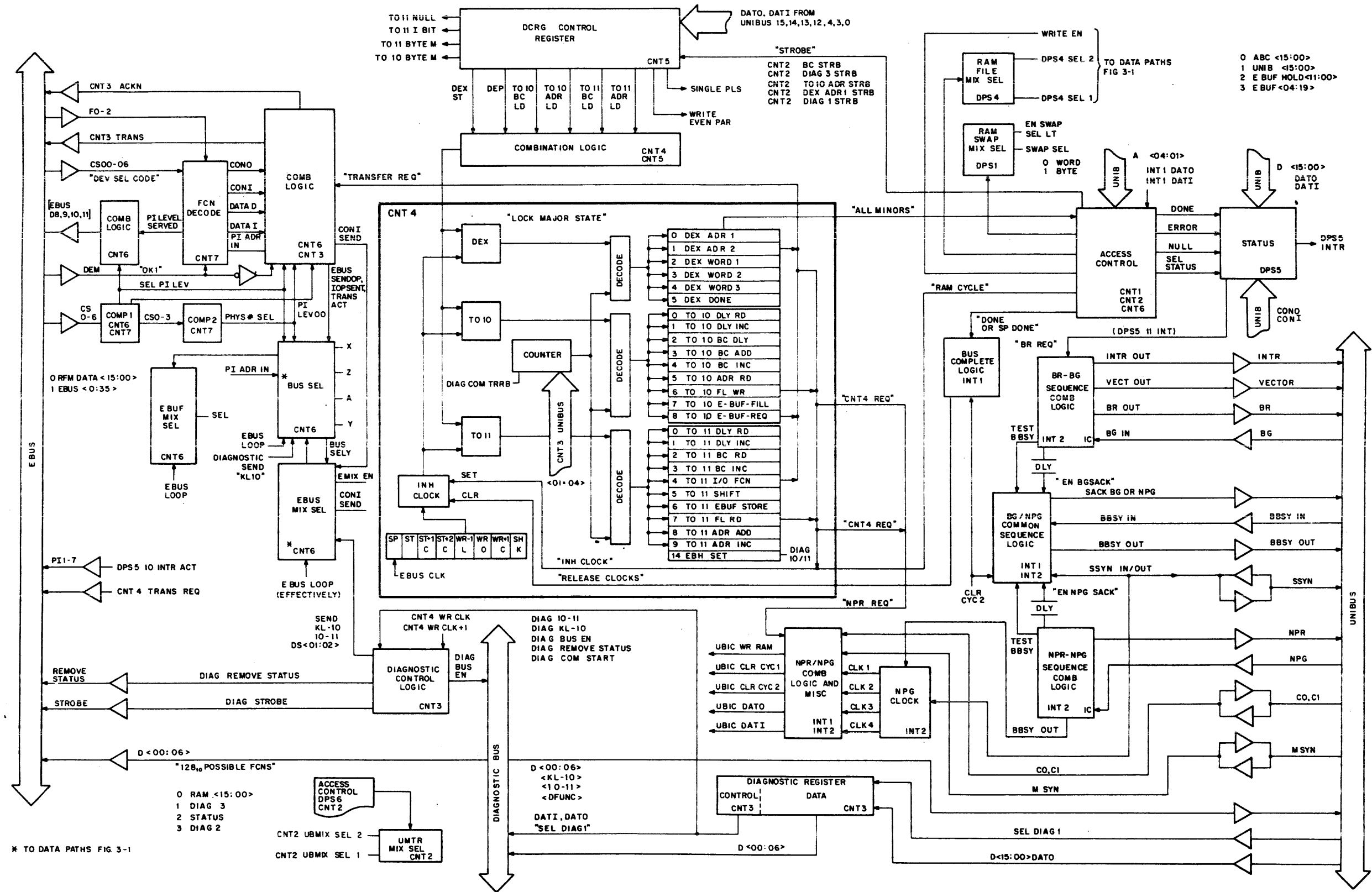
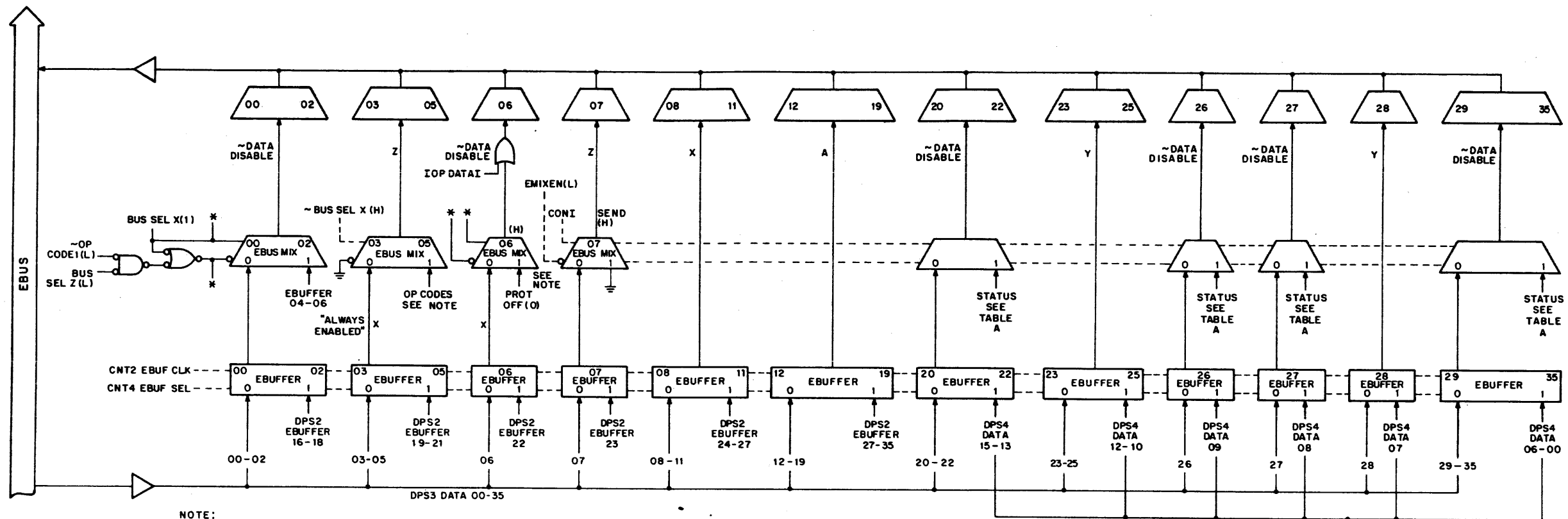

Figure 26 DTE20 Detailed Control Block Diagram



NOTE:

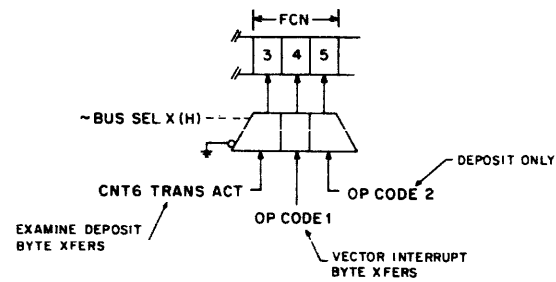

TABLE A	
E BUS MIXER	TYPE OF STATUS
20	~EXT DIAG BUS EN
21	INT1 PWR FAIL
22	DPS5 10 REQ INT
26	DPS5 REQ 10 INT
27	DPS5 10 TO11 ERR TERM
29	DPS5 10 TO11 NORM TERM
30	DPS5 10 TO10 ERR TERM
31	DPS5 10 TO10 NORM TERM
32	DPS3 P10 EN
33	DPS3 PIA 4 (1)
34	DPS3 PIA 2 (1)
35	DPS3 PIA 1 (1)

BUS SELECTS	WAYS OF GETTING THE SELECT
Z	1.) CNT6 EBUS SEND OP 2.) BUS SEL X
X	1.) CNT4 EBUS LOOP 2.) CNT6 DIAG SEND 3.) CNT6 IOP SENT (1) ^ [CNT7 DATA1 ^ CNT4 DEX (1)]
Y	1.) BUS SEL X 2.) BUS SEL A 3.) CNT6 TO10 DATA CYC = CNT4 TO10 TRANS (1) ^ CNT6 IOP SENT
Z	1.) ~CNT6 OP CODE 2.) BUS SEL X
DATA DISABLE	1.) ~EXT DIAG BUS CON EBUS DATA DISABLE

CNT6 E BUFFER SELECT	
0	E BUFFER 00-19 ← E BUFFER 16-35 ← E BUFFER 20-35 ← RAM DATA 15-00
1	E BUFFER 00-35 ← EBUS 00-35

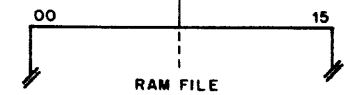

Figure 27 DTE20 EBus and EBuffer Mixers

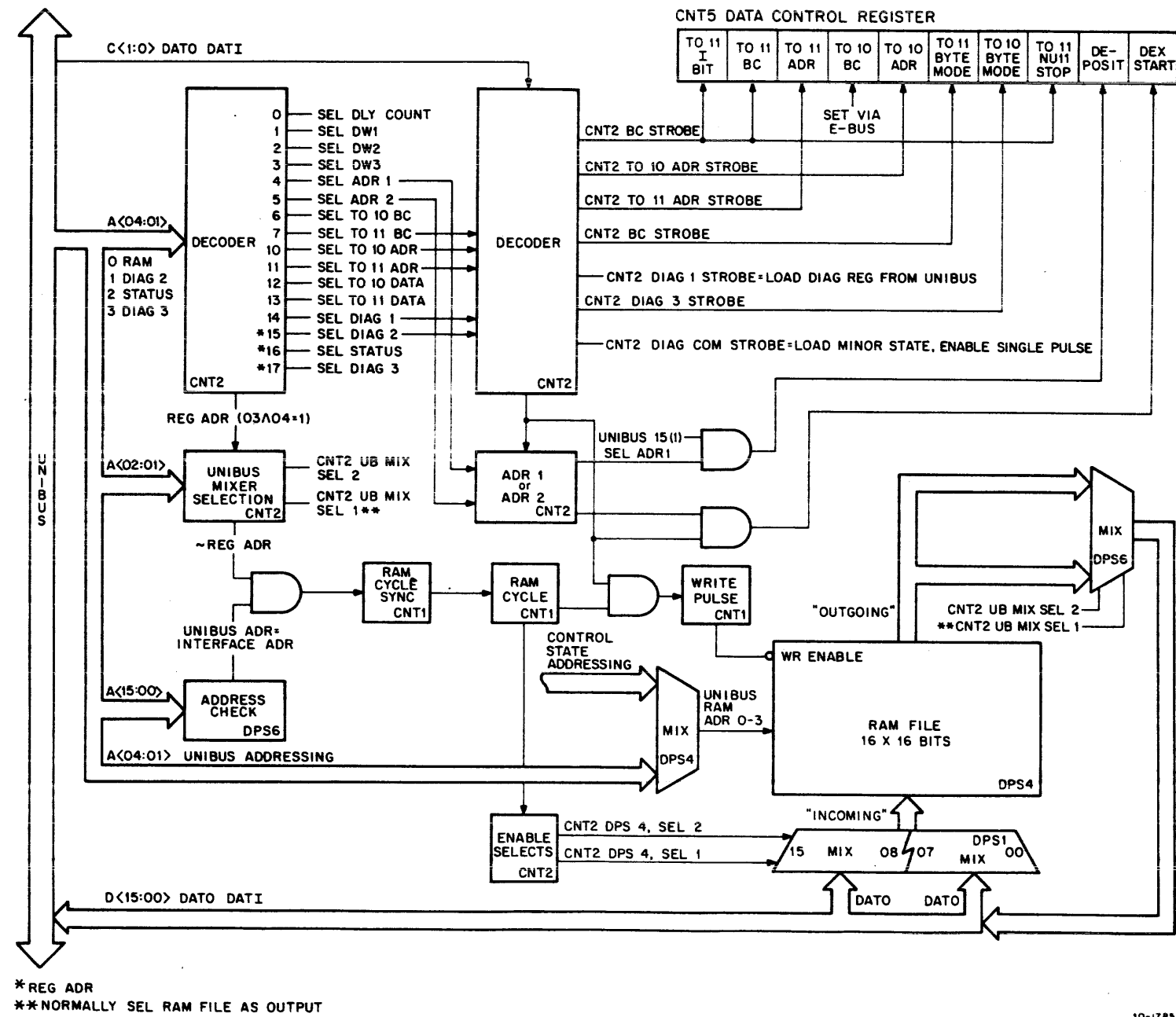
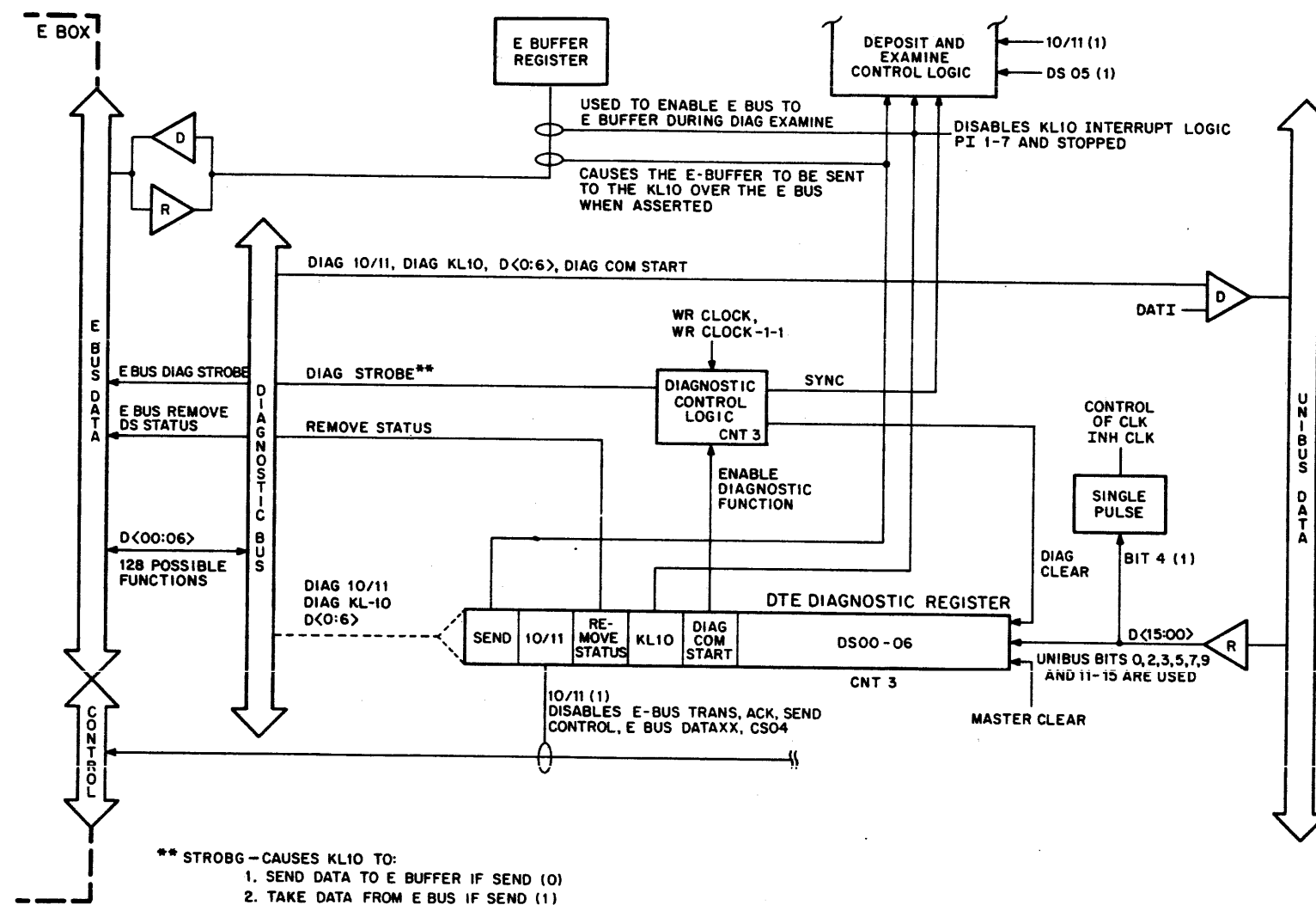

Figure 28 DTE20 Interface Address and Access Control Simplified



10-1846

Figure 29 DTE20 Simplified Diagnostic Functional Diagram

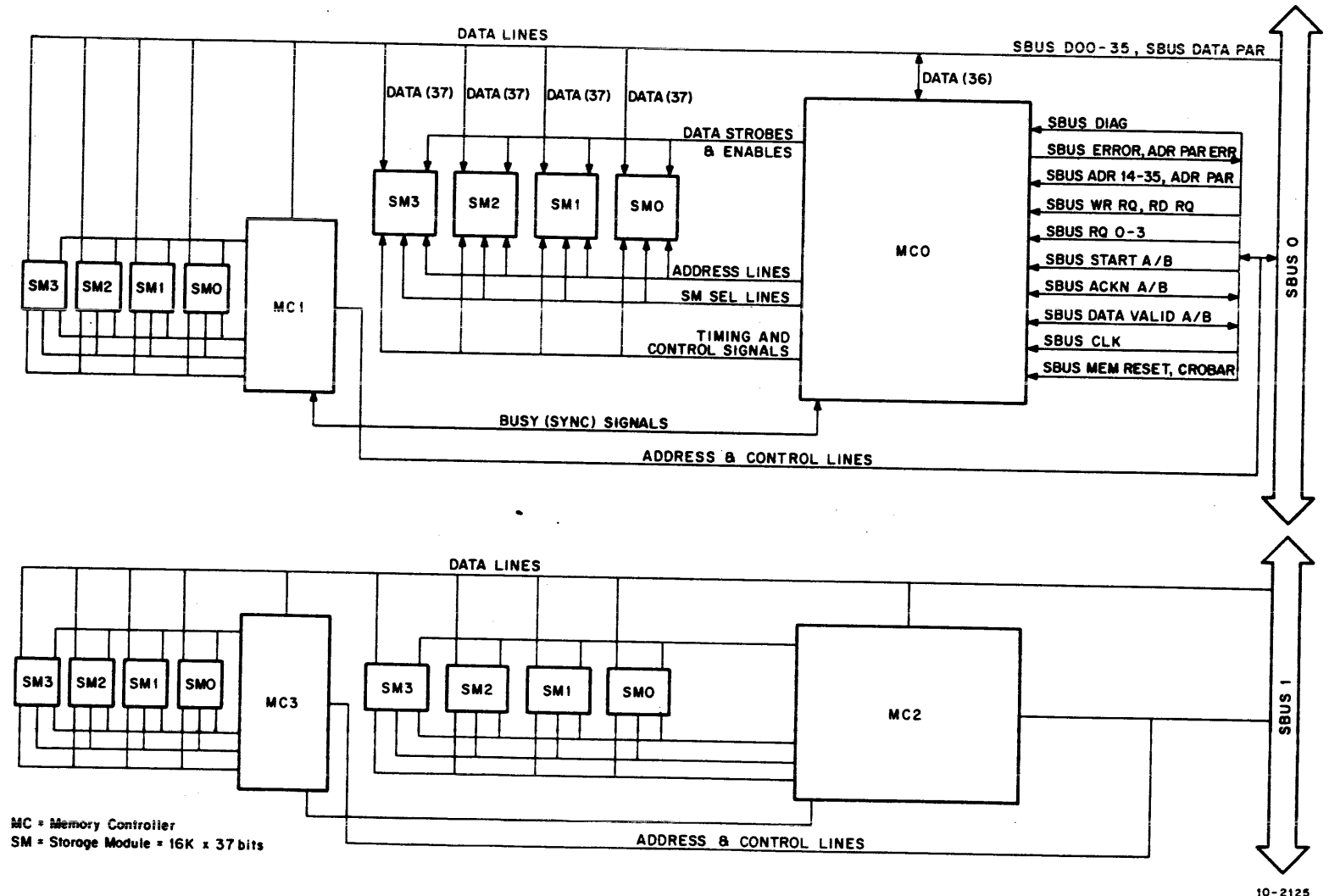
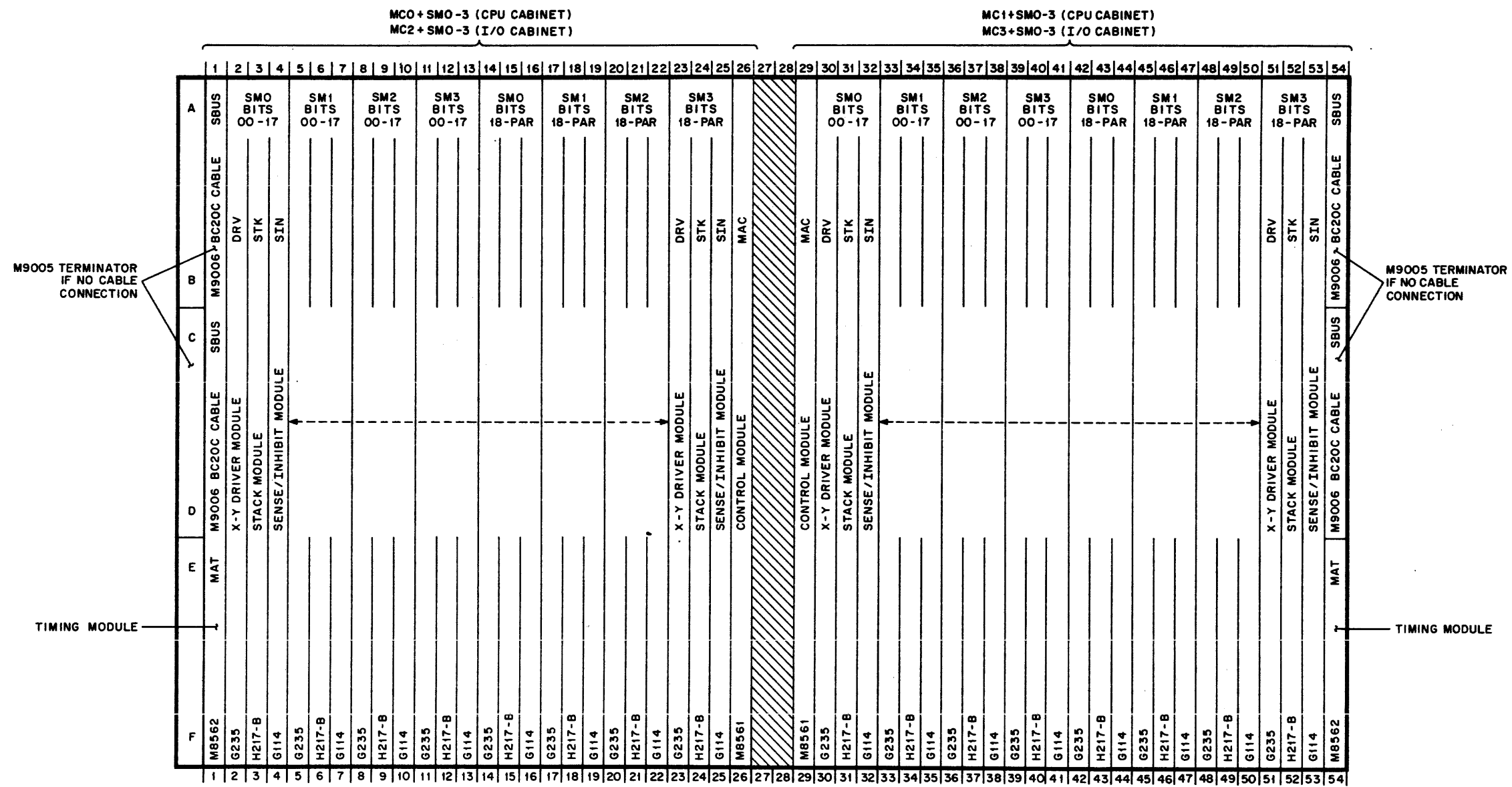

Figure 30 MA20 Internal Memory



NOTES:
 1. Viewed from wire side
 2. MU same for CPU and I/O cabinets

10-2126

Figure 31 MA20 Module Utilization

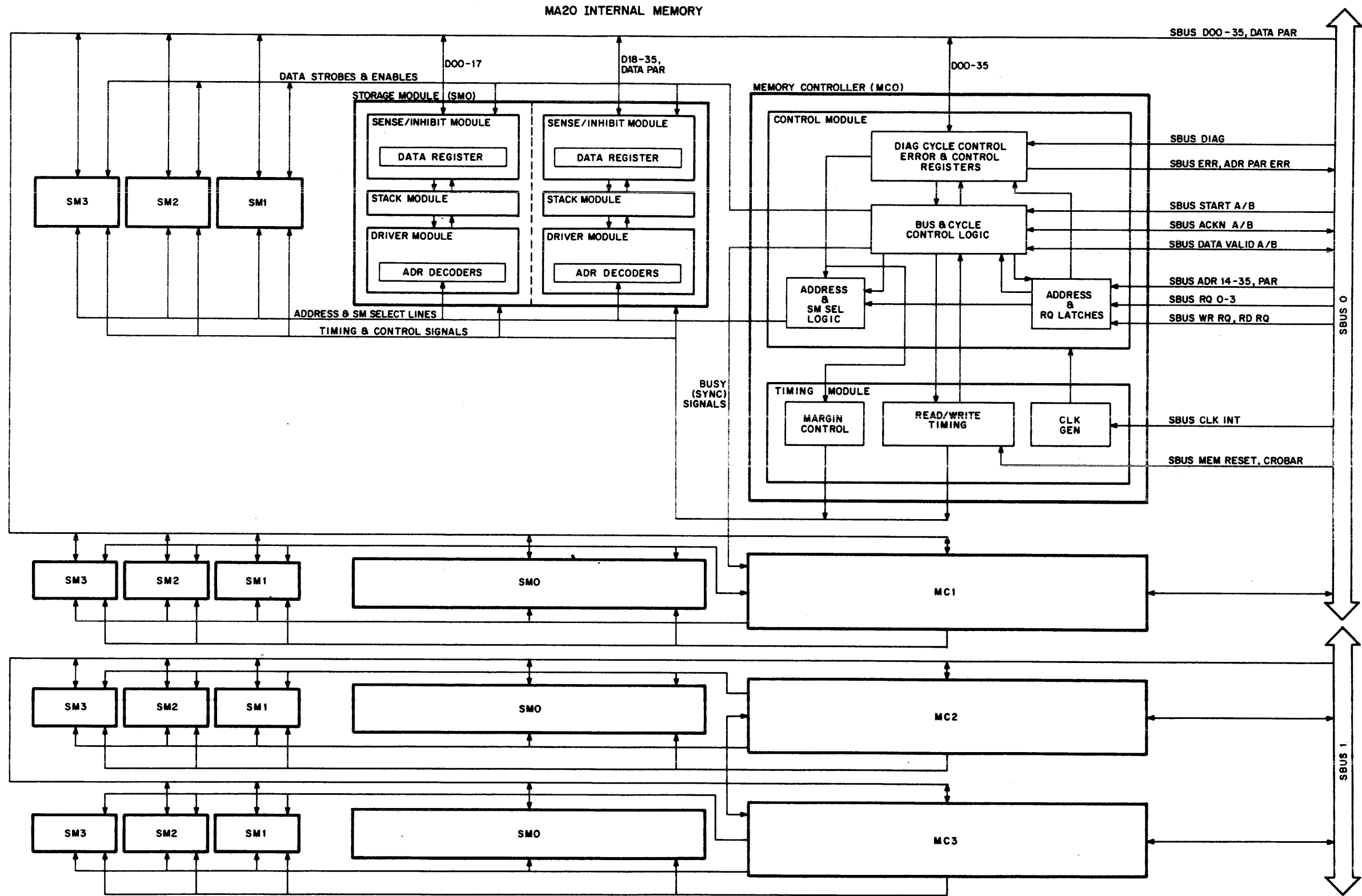

10-2127

Figure 32 MA20 Functional Block Diagram

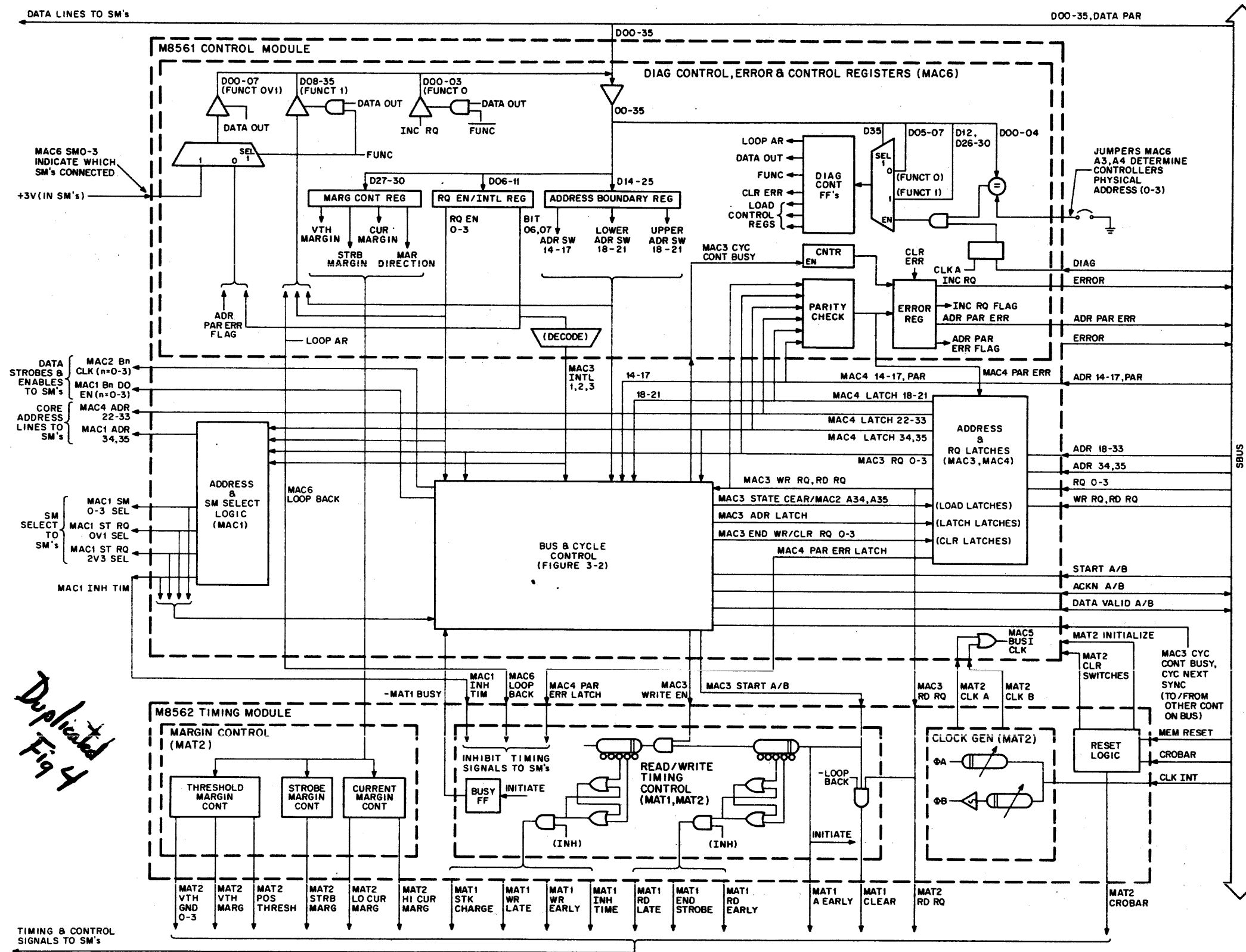
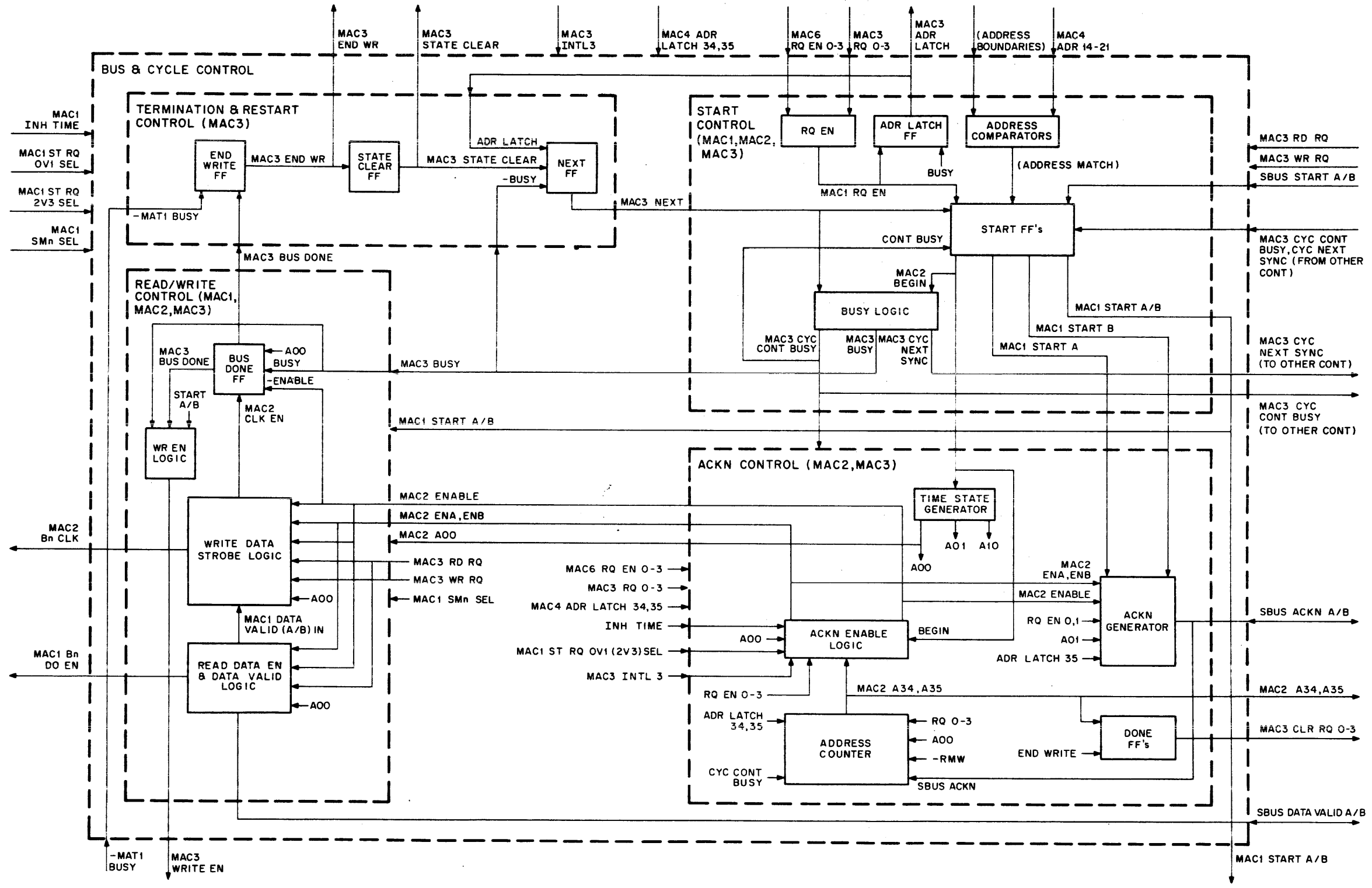
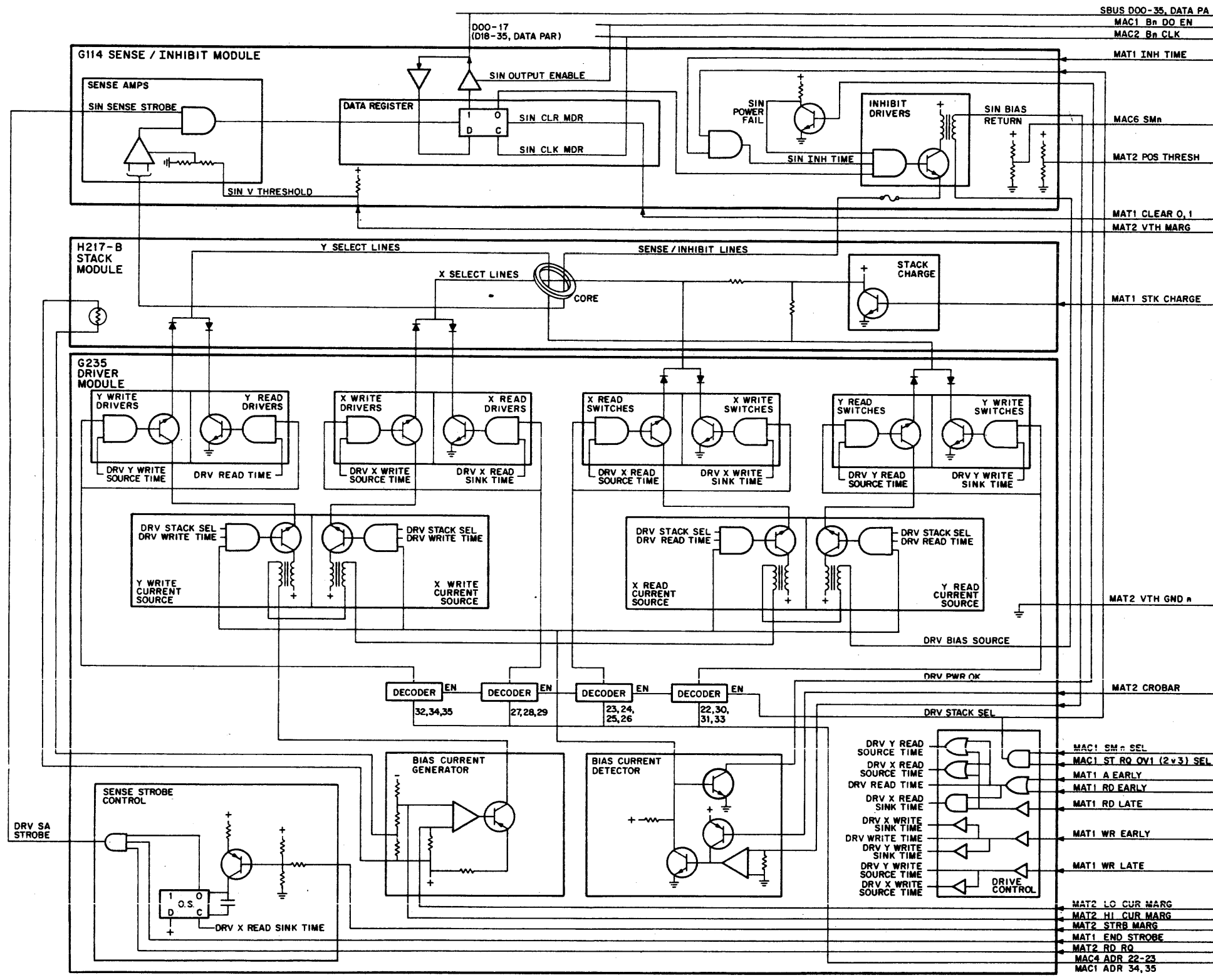

Figure 33 MA20 Controller Detailed Block Diagram



10-2162

Figure 34 MA20 Bus and Cycle Control



10-2167

Figure 35 MA20 Storage Module Detailed Block Diagram

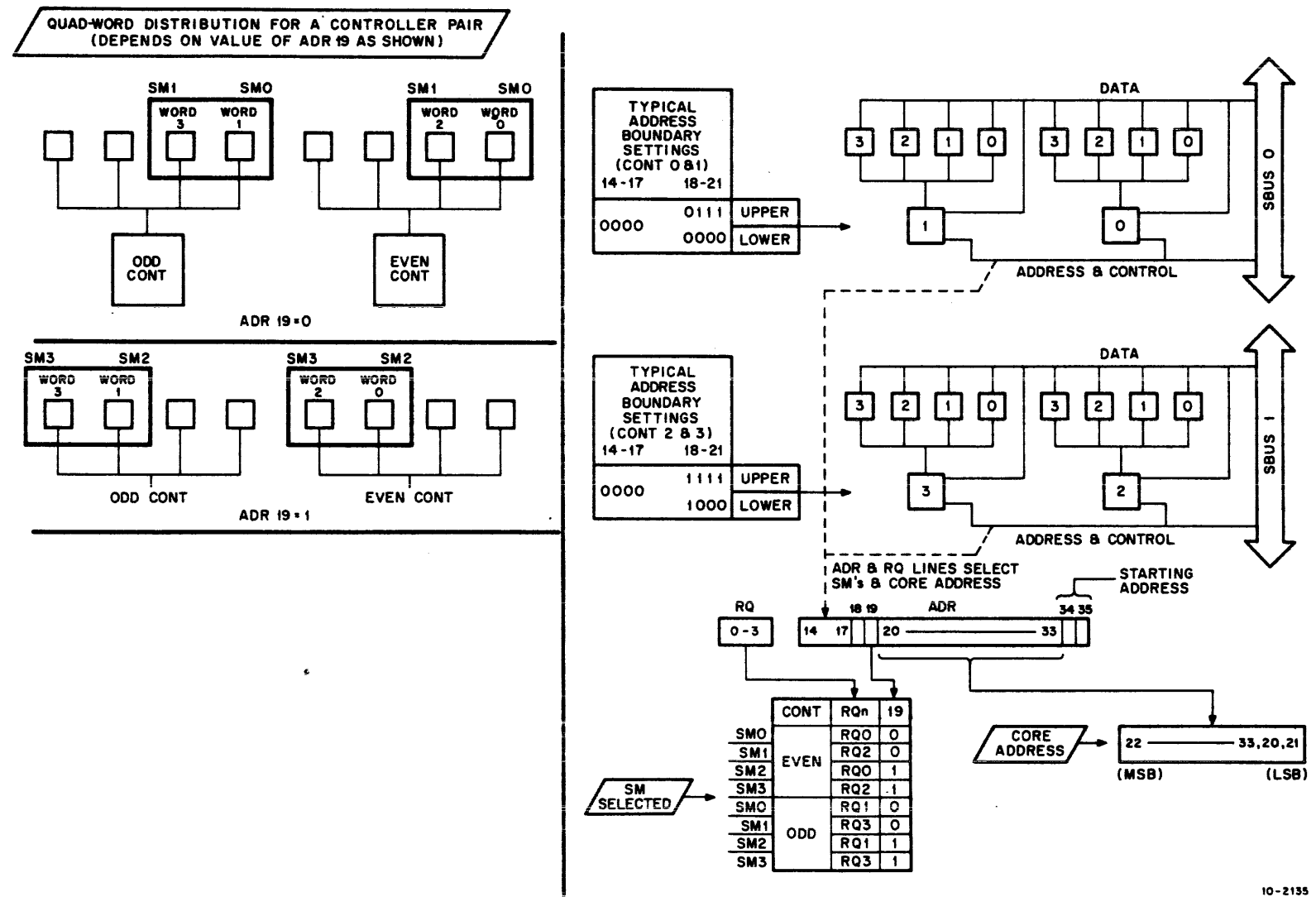

Figure 36 MA20 Memory Selection 4-Way Interleave Mode

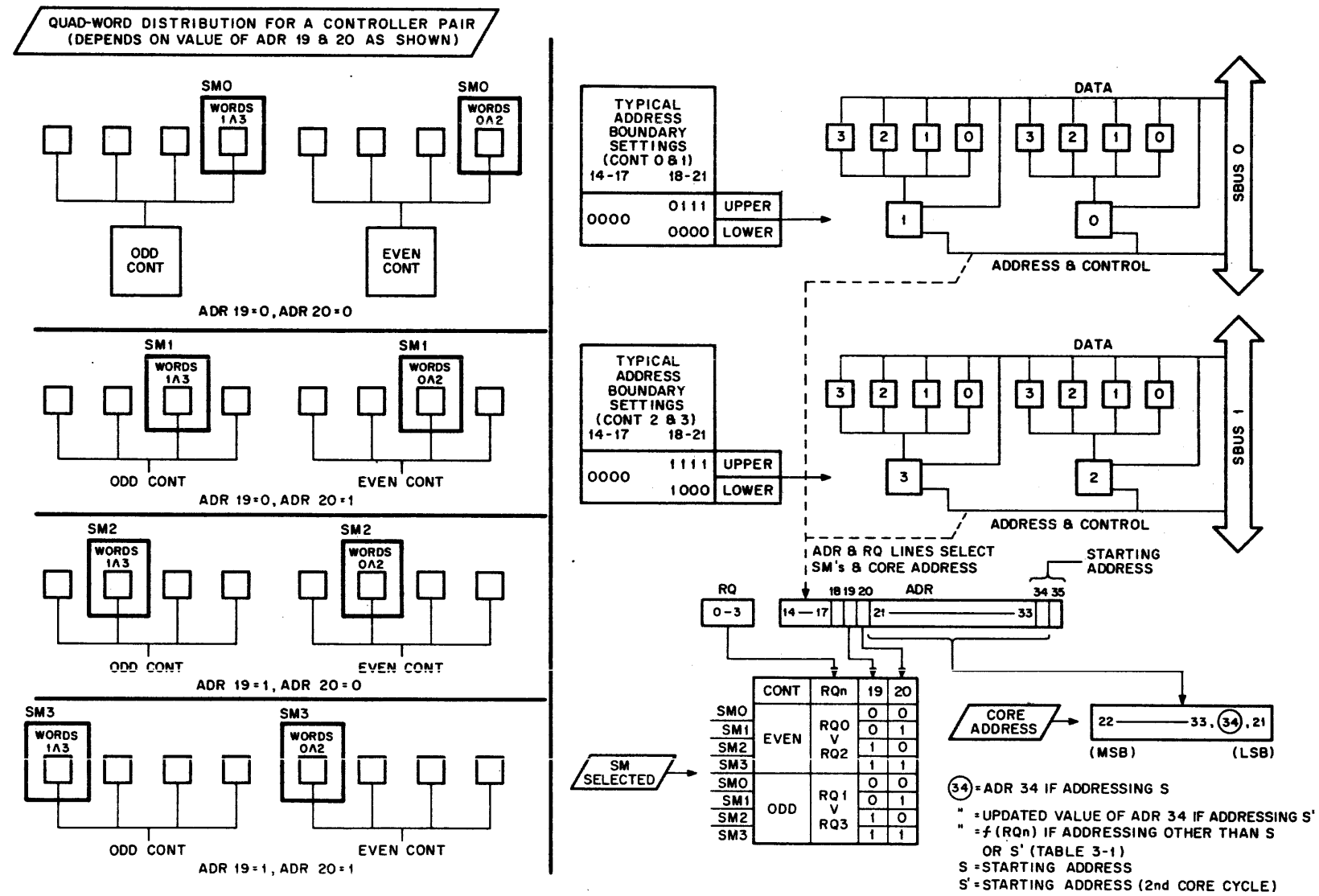

Figure 37 MA20 Memory Selection 2-Way Interleave Mode

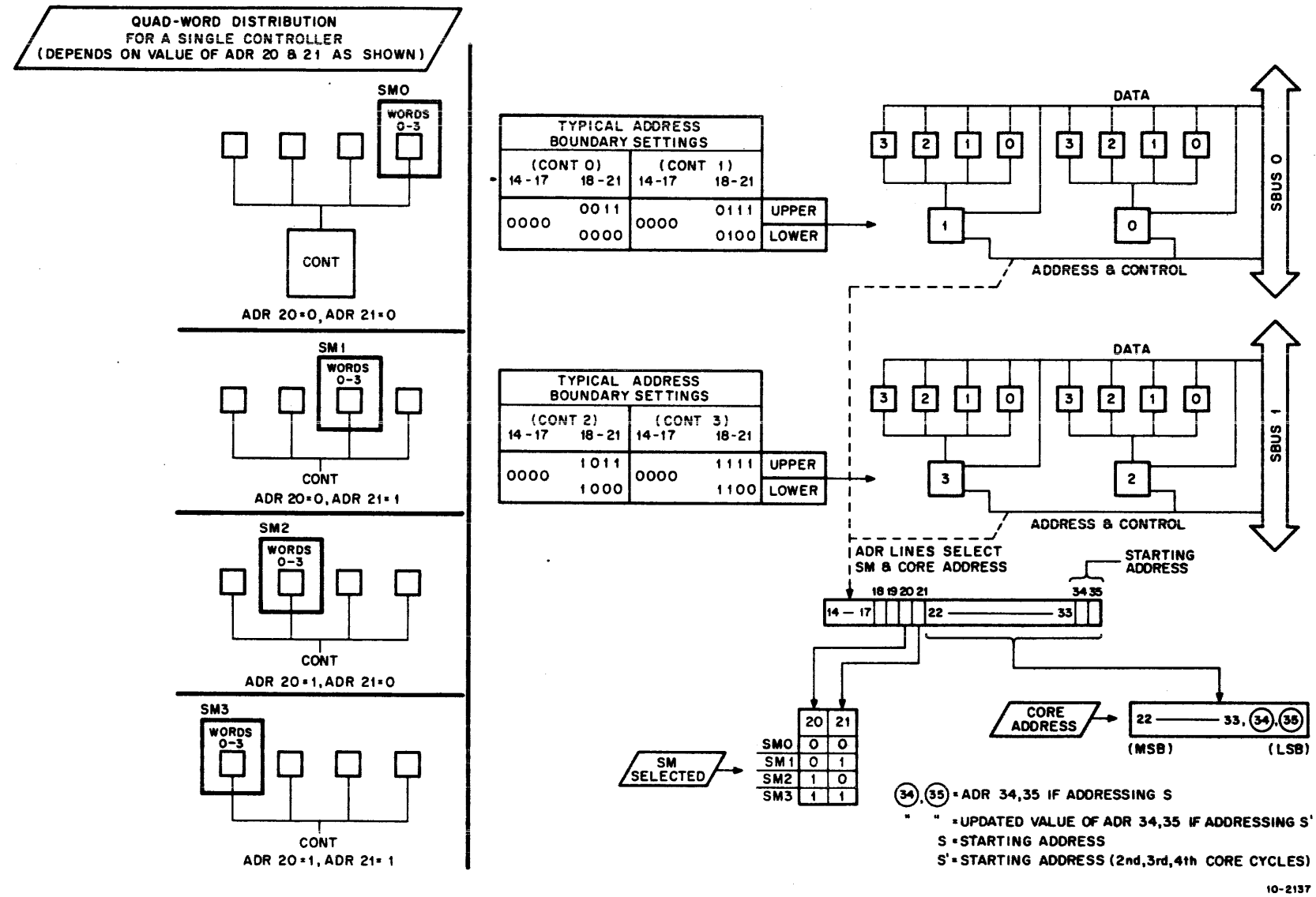
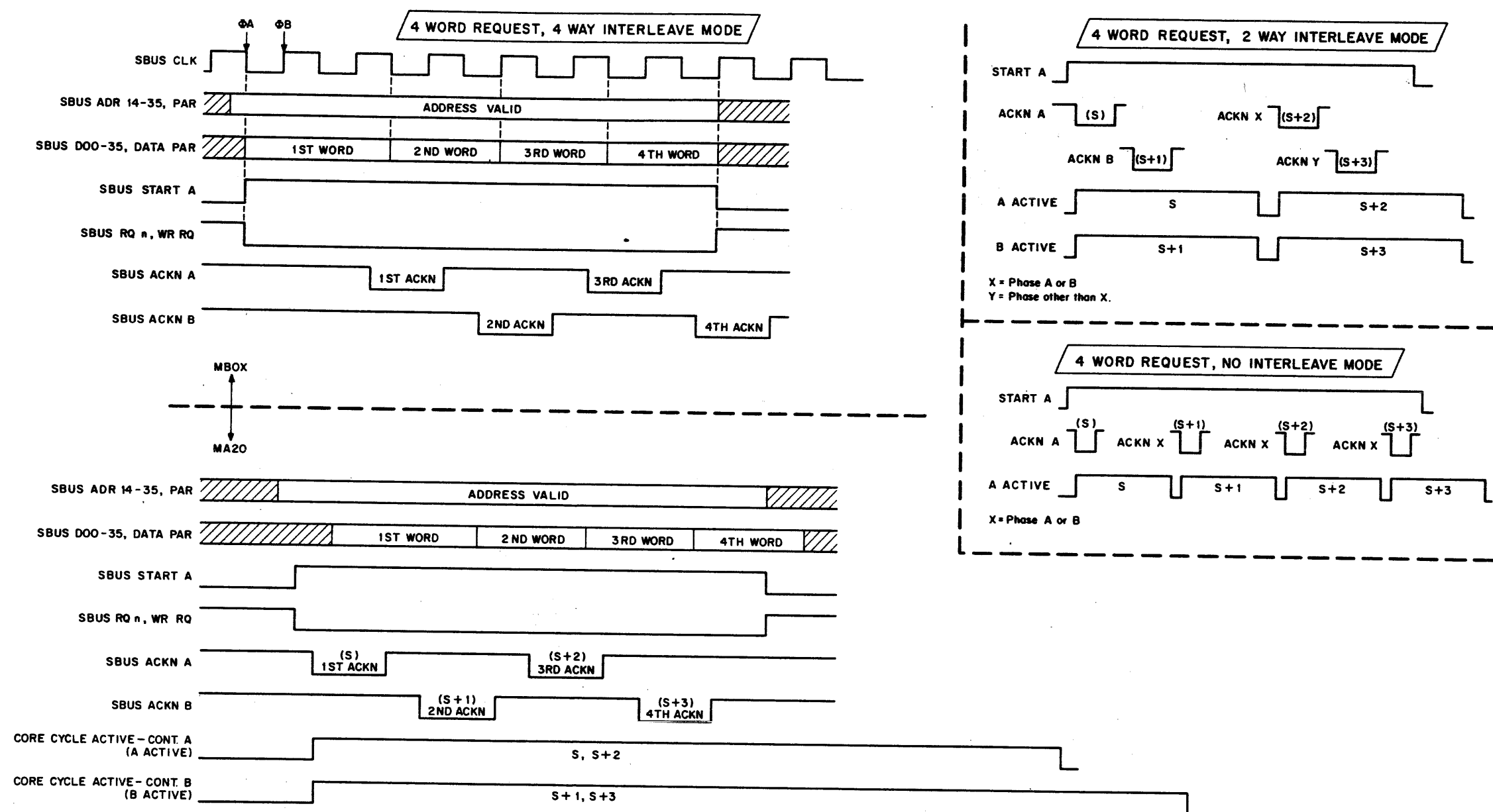

Figure 38 MA20 Memory Selection Non-Interleave Mode



10-2132

Figure 39 MA20 SBus Write Timing Diagram

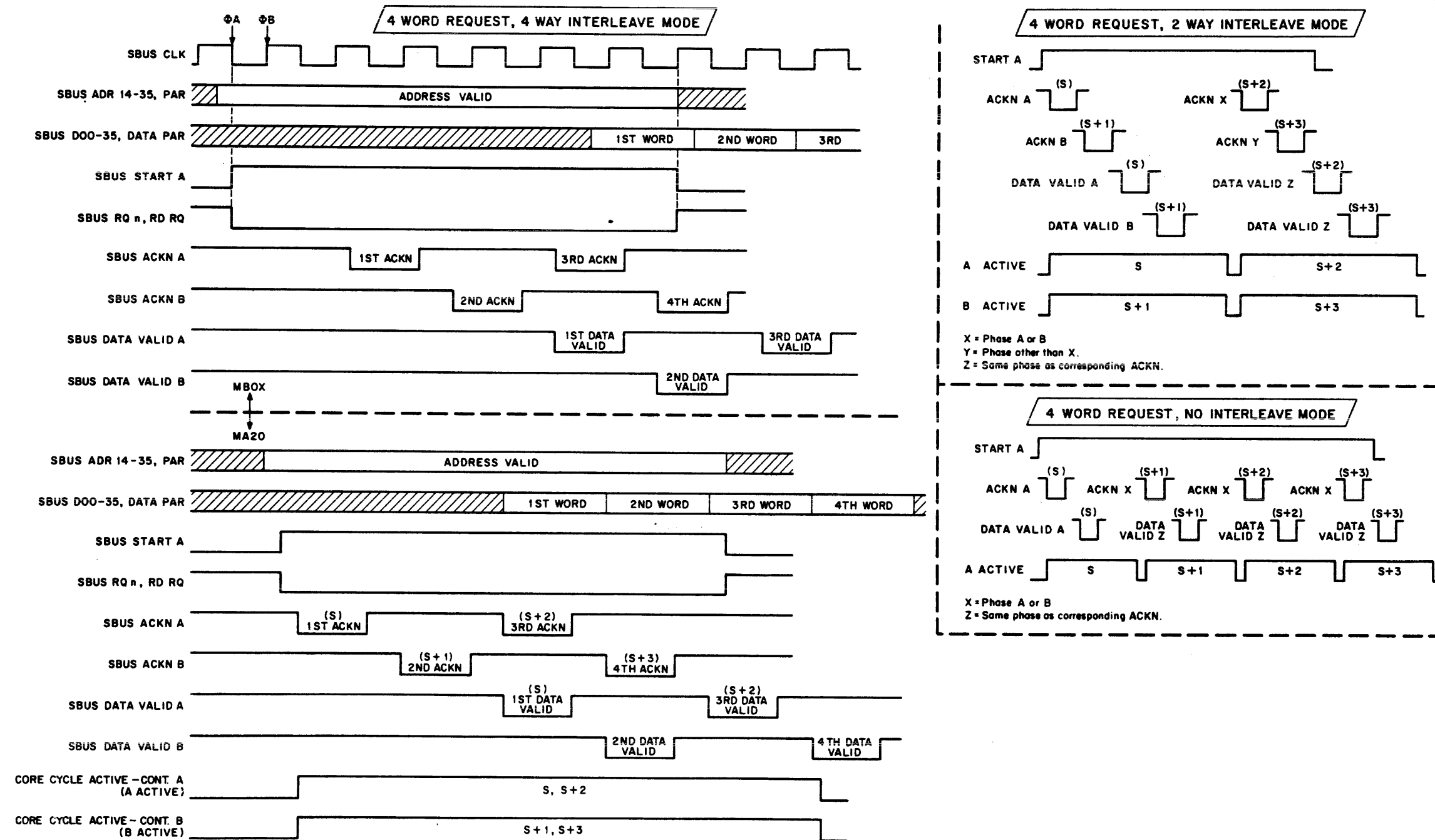
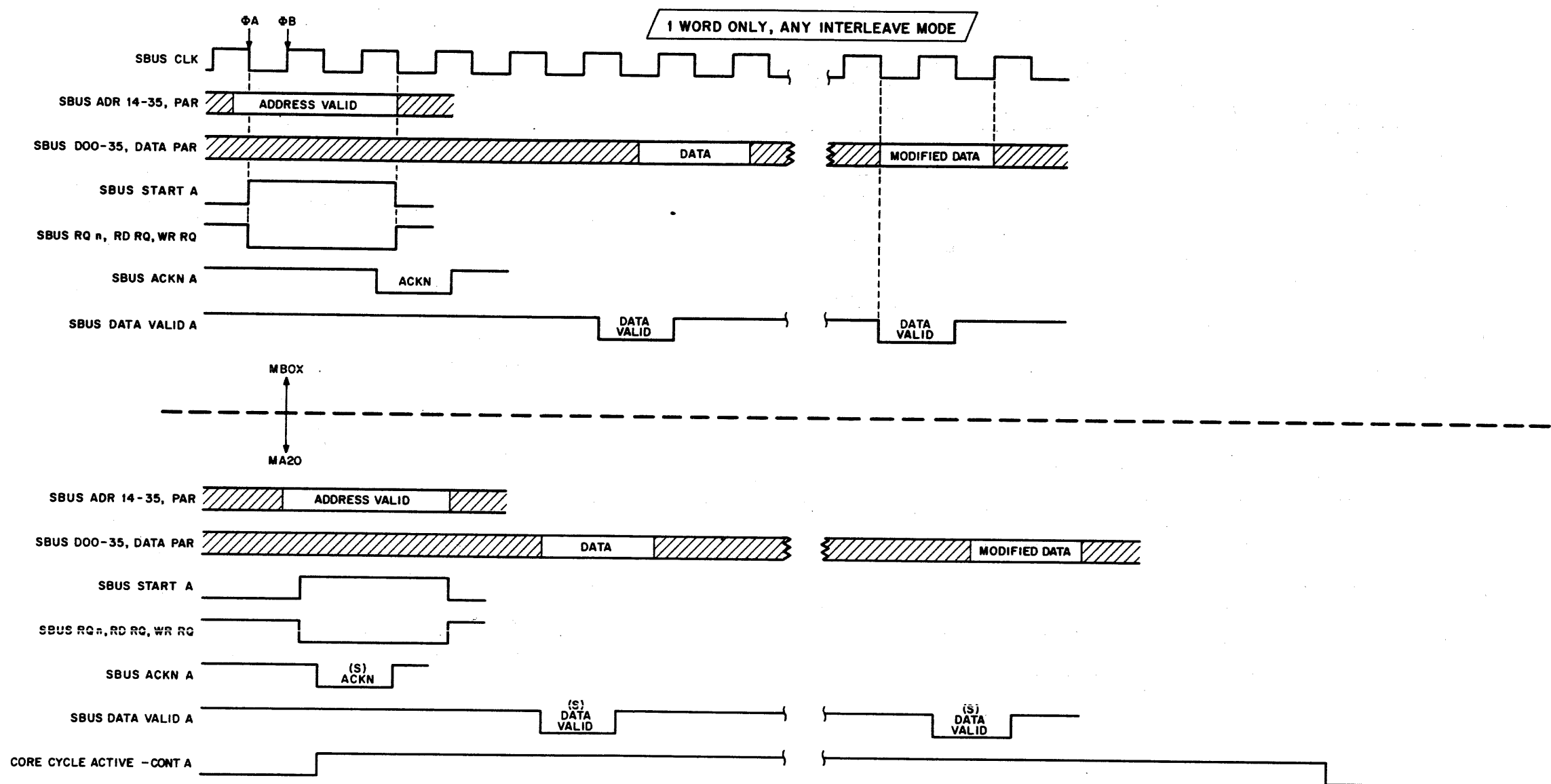

Figure 40 MA20 SBus Read Timing Diagram



10-2134

Figure 41 MA20 SBus RMW Timing Diagram

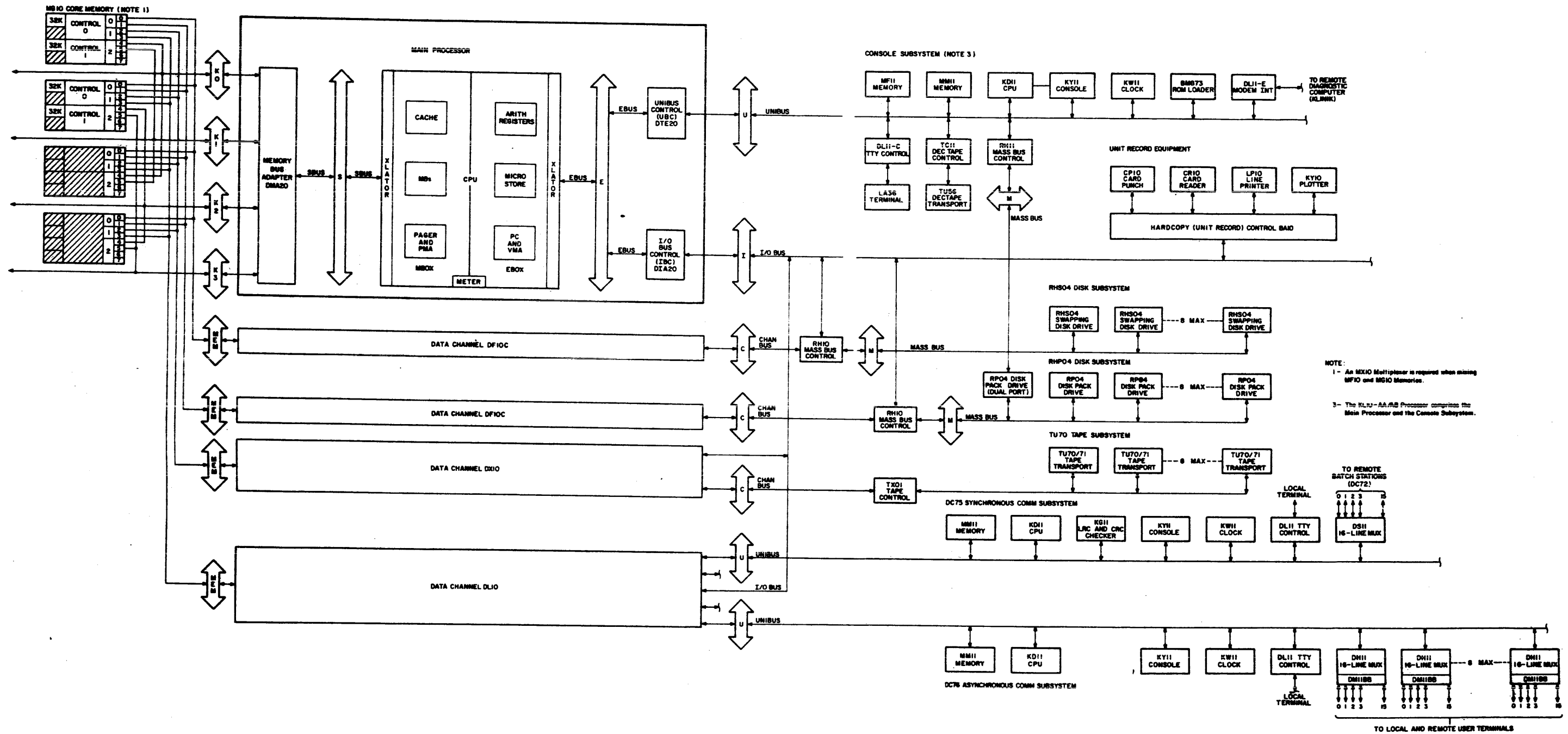
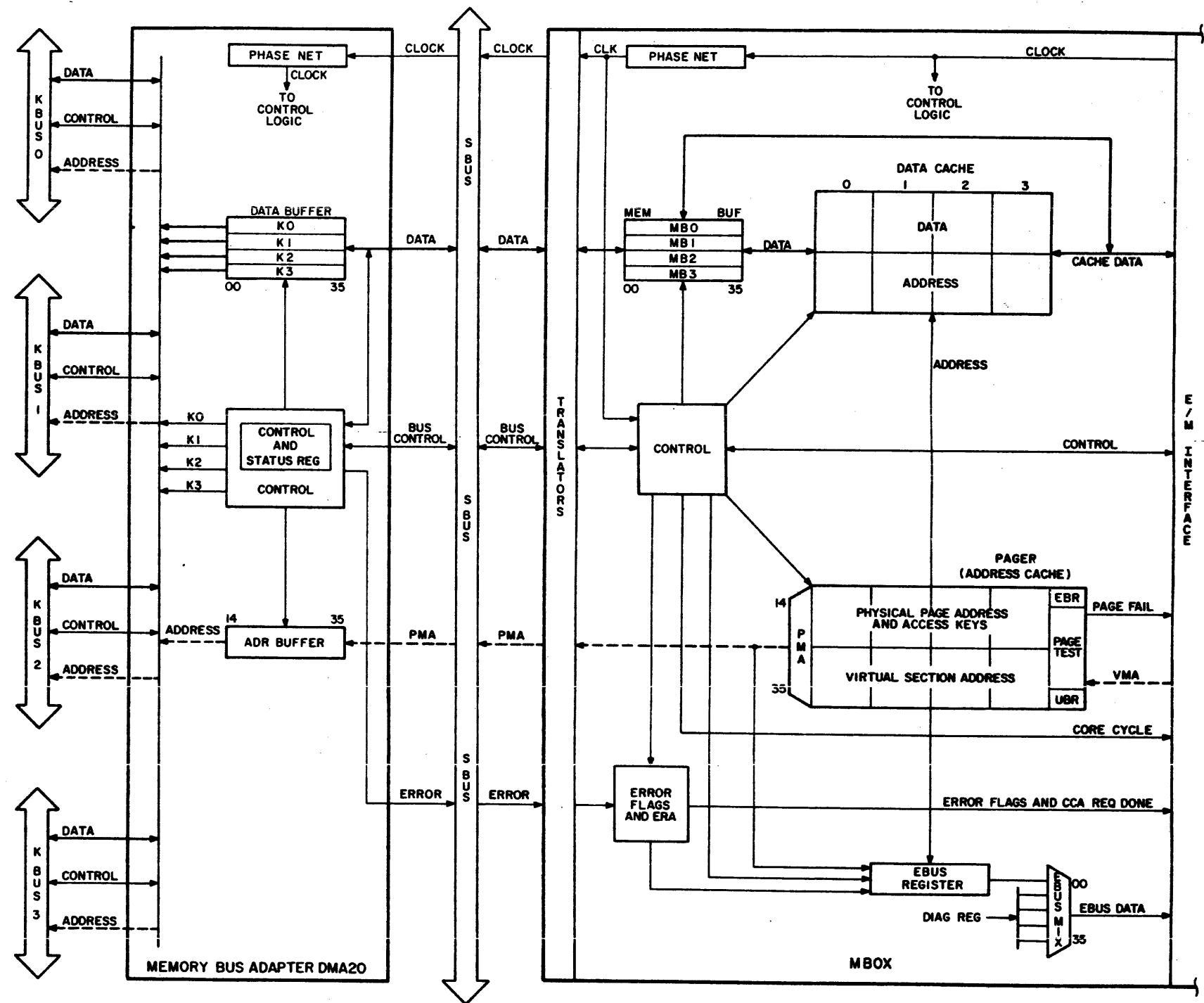

Figure 42 DECsystem-1080 Block Diagram (Typical)



10-1920-A

Figure 43 Main Processor Subsystem Block Diagram (Sheet 1 of 2)

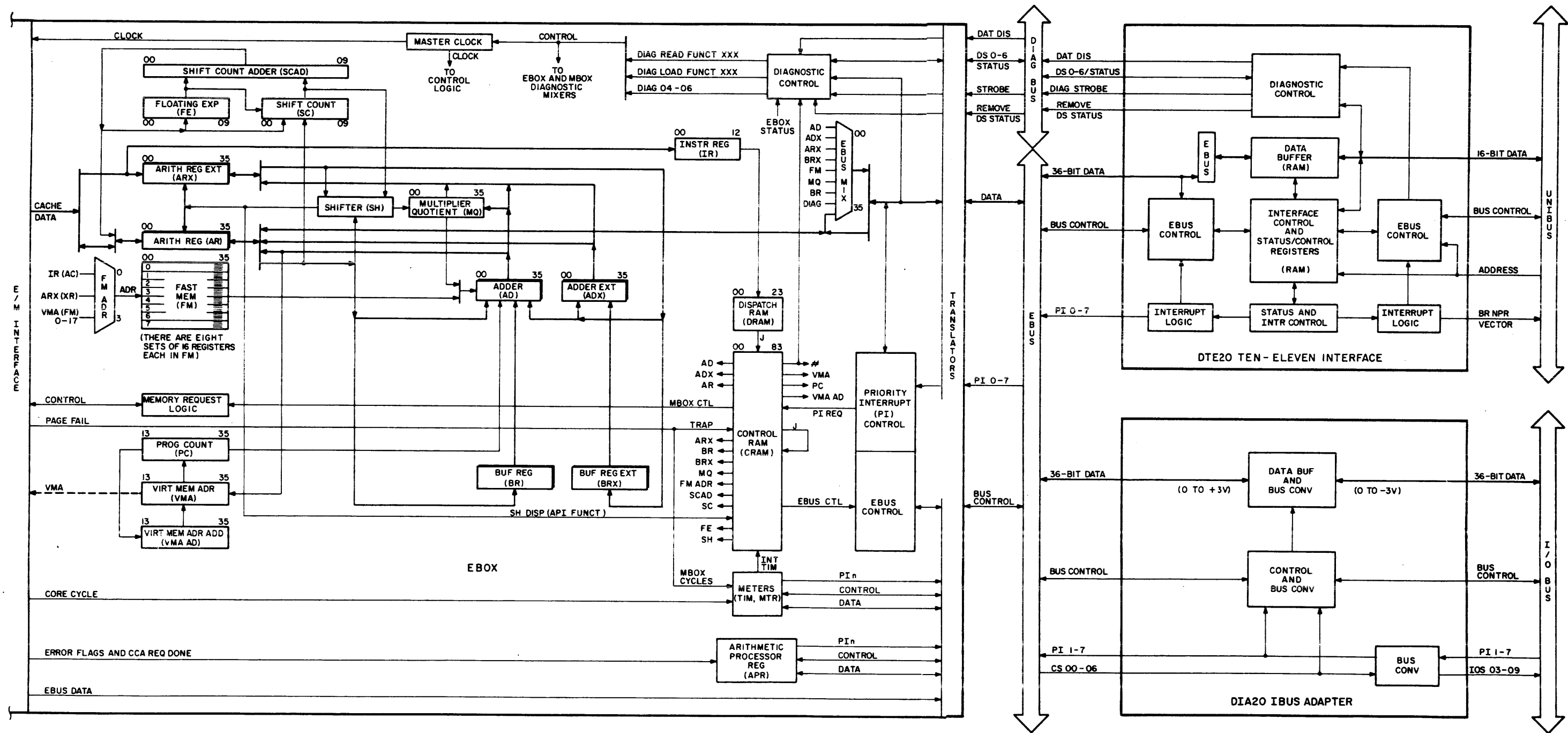

Figure 43 Main Processor Subsystem Block Diagram (Sheet 2 of 2)

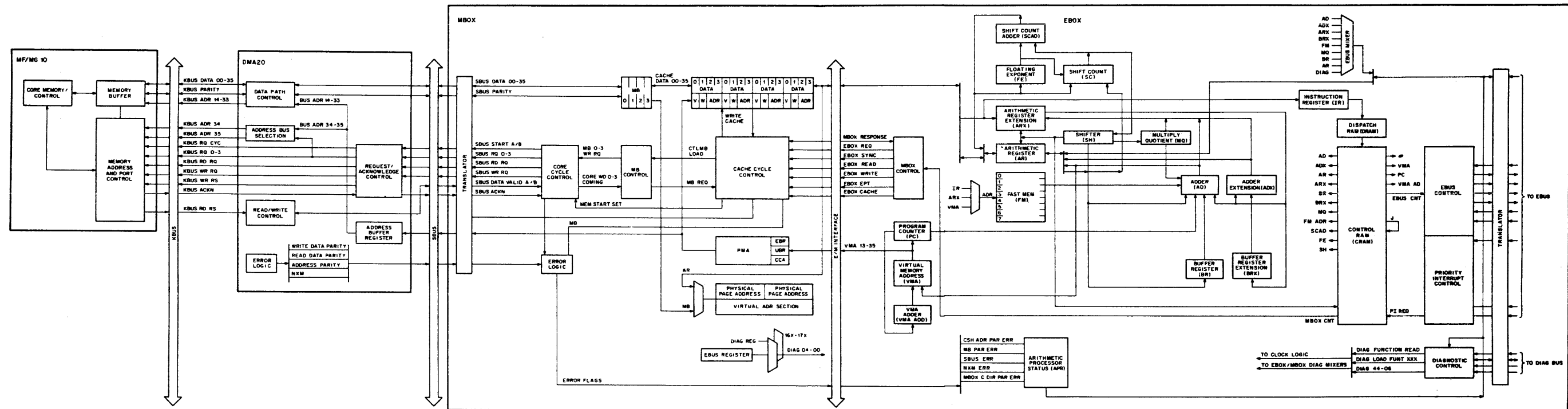
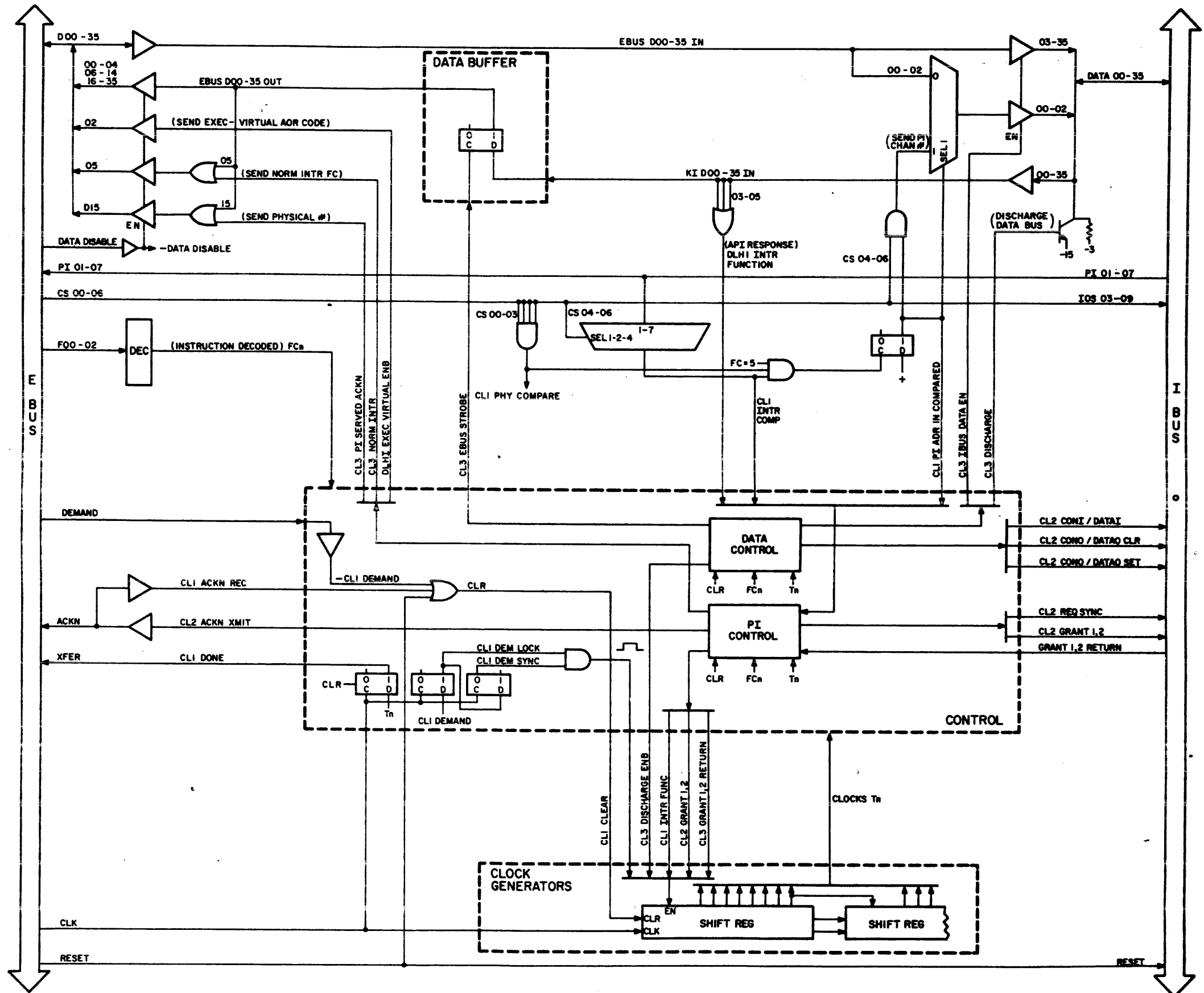

Figure 44 Detail Channel Interface Block Diagram



10-1300

Figure 45 DIA20 Detailed Block Diagram

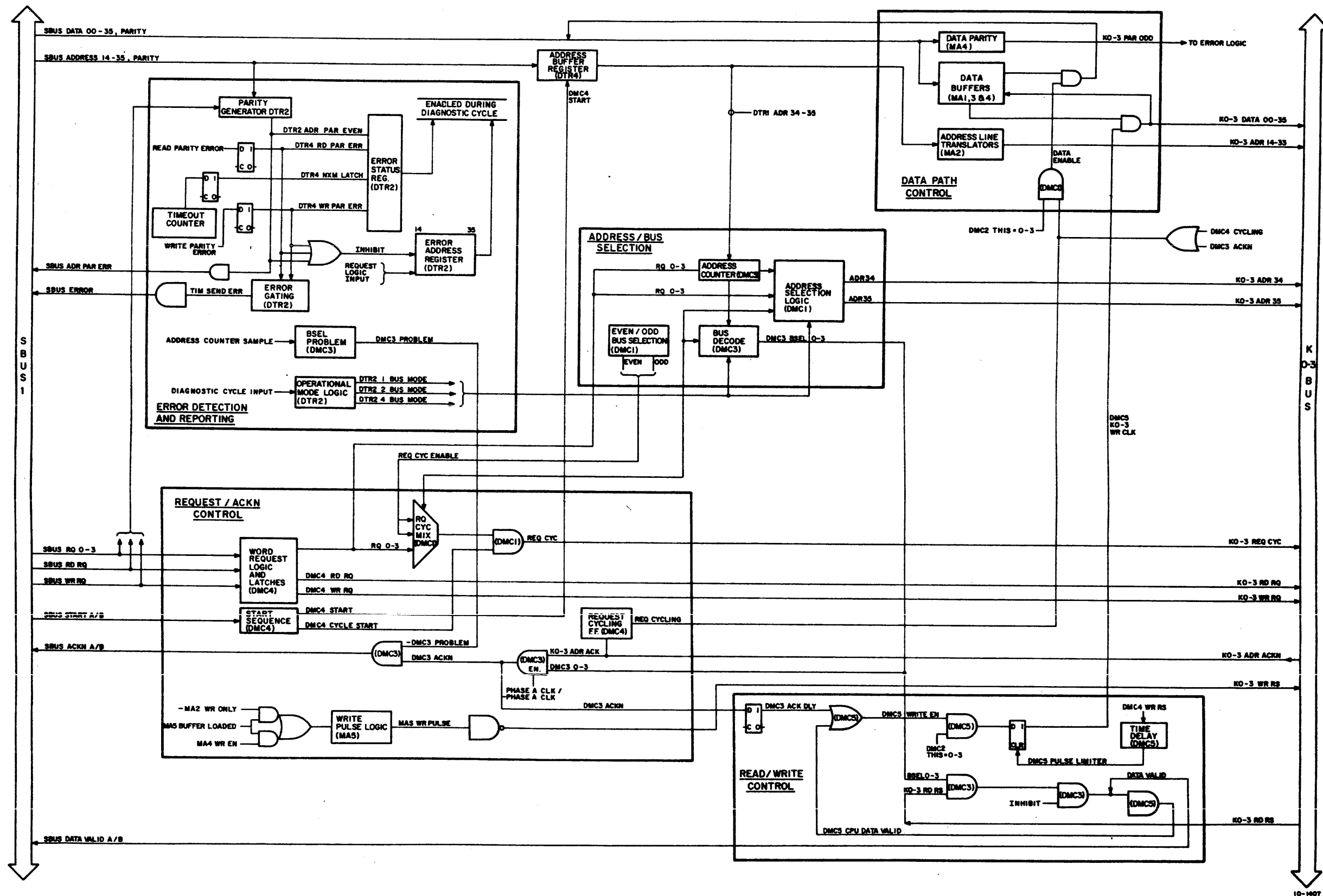

Figure 46 DMA20 Functional Block Diagram

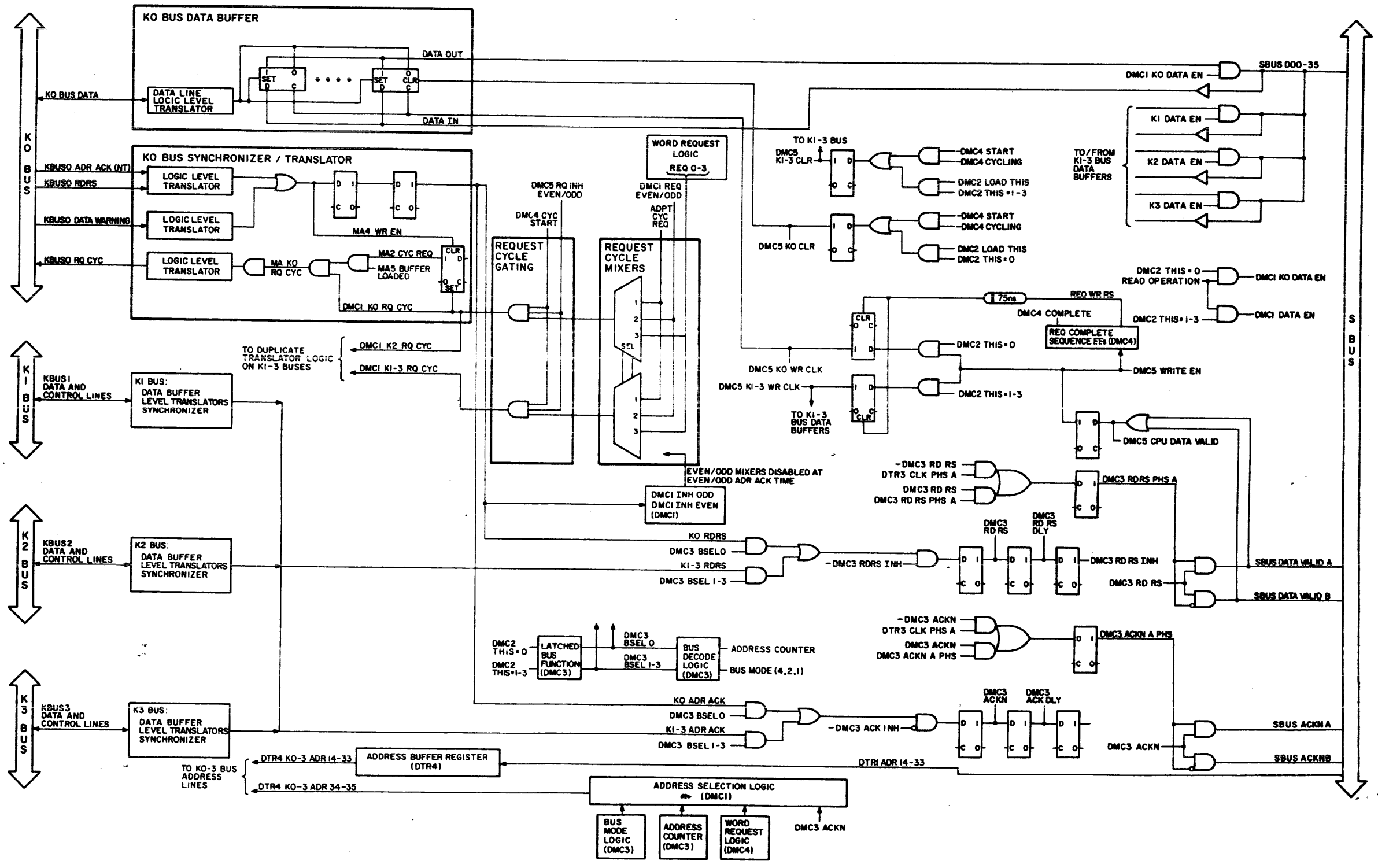

Figure 47 DMA20 Detailed Logic Block Diagram

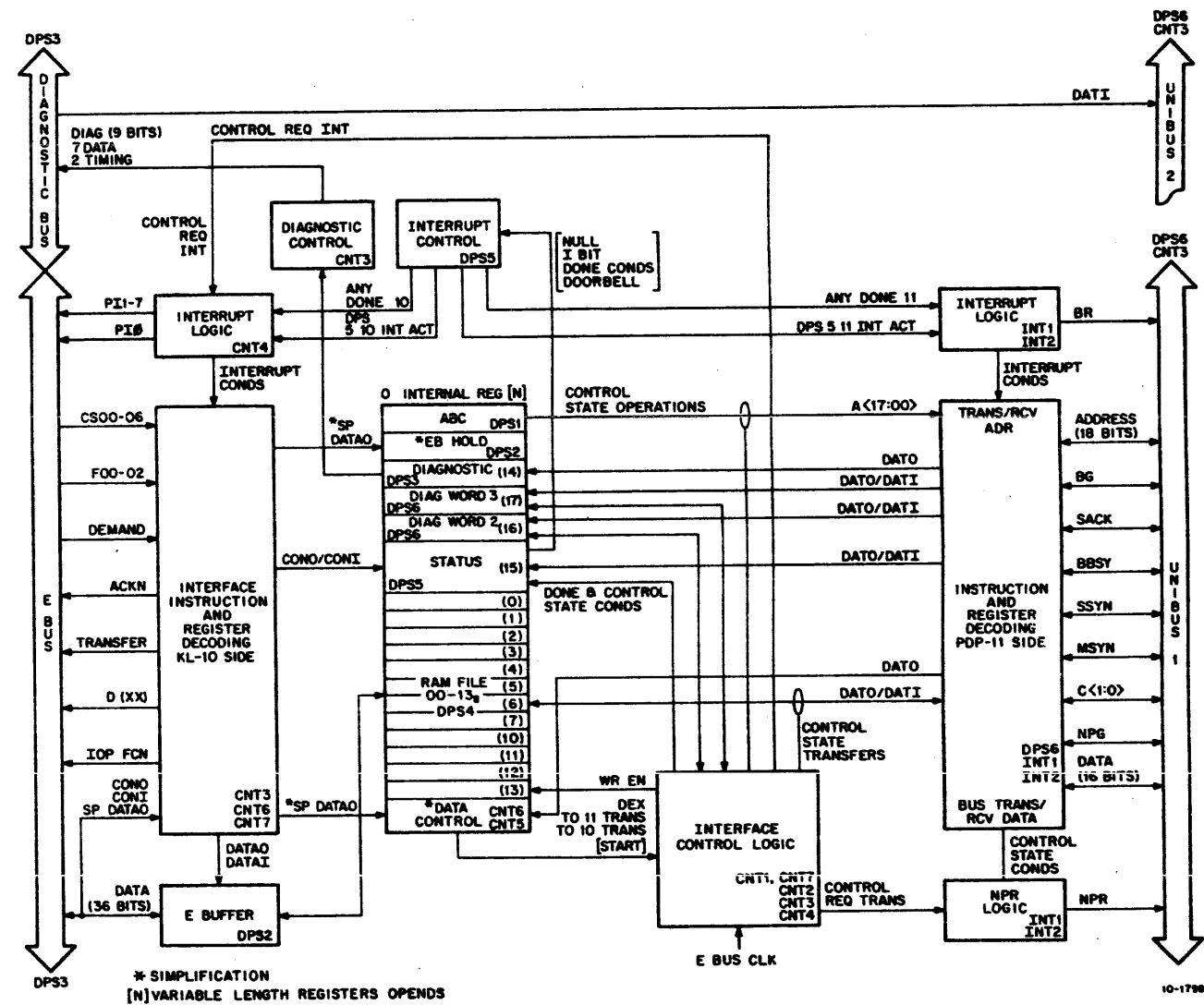
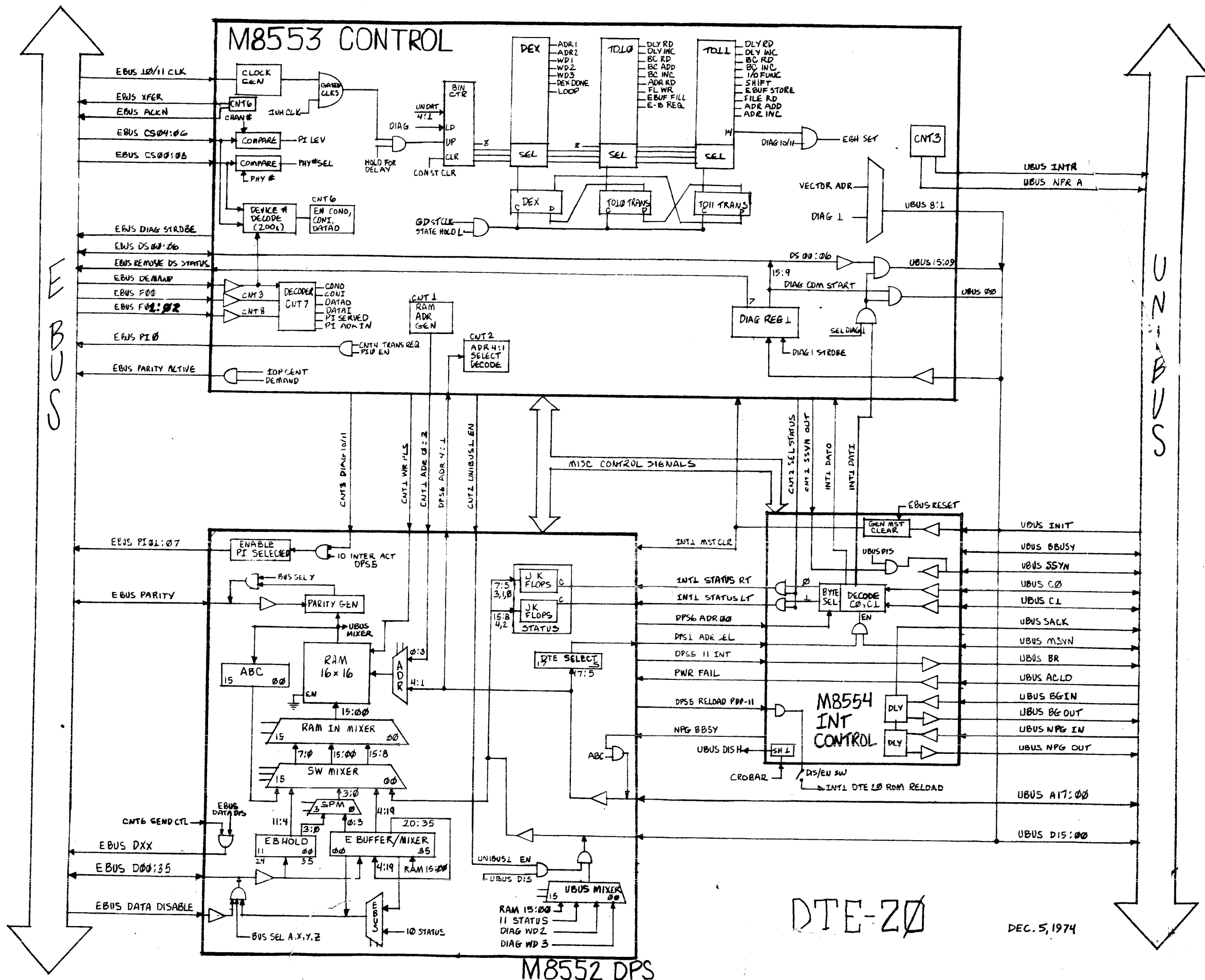

Figure 48 DTE20 Functional Block Diagram (Simplified)



DTE-20

DEC. 5, 1974

M8552 DPS

FIGURE 49 DTE