

VAXstation II/GPX Owner's Manual, BA123 Enclosure

Order No. EK-105AA-OW-001

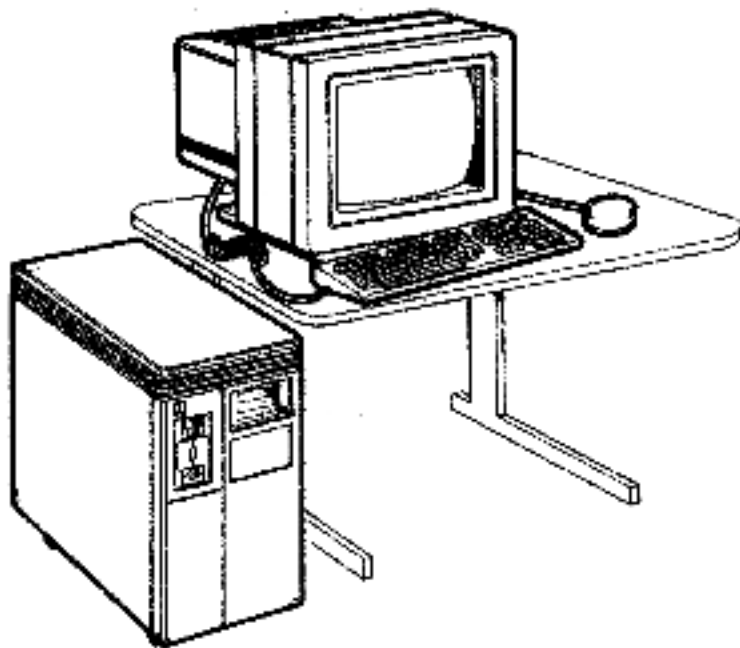

**digital equipment corporation
maynard, massachusetts**

First printing, January 1986
Revised, February 1987

The information in this document is subject to change without notice and should not be construed as a commitment by Digital Equipment Corporation.

Digital Equipment Corporation assumes no responsibility for any errors that may appear in this document.

The software, if any, described in this document is furnished under a license and may be used or copied only in accordance with the terms of such license. No responsibility is assumed for the use or reliability of software or equipment that is not supplied by Digital Equipment Corporation or its affiliated companies.

Copyright ©1986, 1987 by Digital Equipment Corporation.

All Rights Reserved.

The READER'S COMMENTS form on the last page of this document requests the user's critical evaluation to assist in preparing future documentation.

The following are trademarks of Digital Equipment Corporation:

DEBIT	DEBOL	ThinWire
DEC	MASSBUS	ULTRIX-32
DECconnect	MicroVAX	ULTRIX-32m
DECmate	MicroVMS	UNIBUS
DECnet	FDP	VAX
DECLE	P/OS	VAXcluster
DECwriter	Professional	VAXstation
DELNI	Q-bus	VMS
DEMPR	Rainbow	VT
DEONA	RSTS	Week Processor
DRSTA	RSX	
DELNA	RT	

POSTSCRIPT[®] is a trademark of Adobe Systems, Inc.

Tektronix[®] is a registered trademark of Tektronix, Inc.

UNIX[®] is a registered trademark of American Telephone & Telegraph Company.

M1-5635

FCC NOTICE: The equipment described in this manual generates, uses, and may emit radio frequency energy. The equipment has been type tested and found to comply with the limits for a Class A computing device pursuant to Subpart J of Part 15 of FCC Rules, which are designed to provide reasonable protection against such radio frequency interference when operated in a commercial environment. Operation of this equipment in a residential area may cause interference, in which case the user at his own expense may be required to take measures to correct the interference.

Contents

Preface	ix
Description of the VAXstation II/GPX	ix
Conventions Used in This Document	x
Structure of This Document	xi
Part I: Base System Installation	xi
Part II: Operation	xi
Part III: Options	xi
Part IV: Troubleshooting	xi
Part V: Appendixes	xi
Part VI: Glossary	xli
Intended Audience	xli

Part I: Base System Installation

Chapter 1 Preparing for Installation

Check Your Shipment	1-1
Site-Preparation Review	1-3
Space Planning	1-3
The System Unit	1-3
The Color Monitor	1-4
Electrical Requirements	1-5
Environment	1-6
Temperature and Humidity	1-6
Static Electricity	1-7
Clean Area	1-7
Supplies Storage	1-7

Chapter 2 Setting Up the Hardware

Setting Up the Color Monitor	2-2
Setting Up the Keyboard and Pointing Device	2-6
Connecting the VAXstation II/GPX to a Power Source	2-10
Connecting the VAXstation II/GPX to a Network	2-19
Connecting the Ethernet Transceiver Cable to the Workstation	2-19
Connecting to Standard Ethernet	2-20
Connecting to ThinWire Ethernet Using the DESTA	2-21
Testing the VAXstation II/GPX	2-24

Part II: Operation

Chapter 3 VAXstation II/GPX Hardware

VAXstation II/GPX Controls and Indicators	3-1
Halt Enable/Disable Switch (2-position toggle switch)	3-3
Power-Up Mode Selection (3-position rotary switch)	3-4
Baud Rate Selection Switch (8-position rotary switch)	3-4
Light-Emitting Diode (LED) Display	3-4
Printer Port	3-4
The System Power Switch	3-4
The Restart/Run Pushbutton	3-5
The DC OK Indicator	3-5
The Halt Pushbutton	3-6
The Fixed Disk Pushbuttons	3-8
Turning On the System	3-8
Initial Control Panel Switch Settings	3-9
Turning Off the System	3-10
Color Monitor Controls and Indicators	3-10
Fixed Disk Drive	3-13
Tape Drive	3-13
Inserting a Tape Cartridge	3-14
Rewinding and Unloading a Tape Cartridge	3-16
Protecting Tape Cartridges from Accidental Overwriting	3-18

Handling and Storing Tape Cartridges	3-19
Dual Diskette Drive	3-19
Inserting a Diskette	3-22
Protecting Diskettes from Accidental Overwriting	3-23
Handling and Storing Diskettes	3-23
Back-up Copies	3-24

Part III: Options

Chapter 4 Options

Hard-Copy Output Devices	4-2
Printers	4-2
The LN03	4-2
The LN03 PLUS	4-3
The PrintServer 40 (LPS40)	4-4
The LA210	4-6
The LA75	4-7
The LA50	4-8
The LCG01	4-9
Plotter	4-10
The LVP16	4-10
Printer and Plotter Connection to the System	4-11
Input Devices	4-13
The Tablet	4-13
The Mouse	4-14
Memory	4-14
The Memory Modules	4-14
Video	4-15
The Video Subsystem	4-15
Storage Devices	4-16
The Fixed Disk Drives	4-16
The Tape Drive	4-17
The Dual Diskette Drive	4-17

Communications	4-18
The Ethernet Communication Modules	4-18
ThinWire Ethernet Components	4-19
ThinWire Ethernet Cable	4-19
Connectors	4-19
Barrel Connectors and T-Connectors	4-19
DESTA and Transceiver Cable	4-19
Terminators	4-20
Connectors and Terminators	4-20
Additional Equipment	4-21
DIGITAL ThinWire Ethernet Station Adapter (DESTA)	4-21
Modems	4-22
DF224	4-22
DF124	4-22
DF112	4-23
DF03	4-23
The DZQ11 Asynchronous Multiplexer	4-23
The DHV11 Asynchronous Multiplexer	4-24
The DMV11 Synchronous Line Controller	4-24
The DPV11 Synchronous Line Controller	4-25
The KMV11 Programmable Controller	4-27

Part IV: Troubleshooting

Chapter 5 Troubleshooting Procedure

Power-up Messages	5-1
Basic Troubleshooting	5-2
Replacing the Fuse	5-10
Color Monitor	5-10
Mouse Maintenance	5-13
MicroVAX Diagnostic Monitor	5-17
The MicroVAX Diagnostic Monitor Main Menu	5-17
The System Utilities Menu	5-19

Chapter 6 Service

How to Call for Service	6-1
DIGITAL Services	6-2

Part V: Appendixes

Appendix A VAXstation II/GPX System Specifications

Appendix B VAXstation II/GPX Related Documents

Hardware	B-1
ULTRIX Software	B-2
MicroVMS Software	B-4

Part VI: Glossary

Glossary

Index

Figures

1-1 A VAXstation II/GPX in the BA123 Enclosure	1-1
1-2 Dimensions of the System Unit	1-4
1-3 Dimensions of the Color Monitor	1-5
2-1 Keyboard Connection, Color Monitor	2-7
2-2 Pointing Device Connection, Color Monitor	2-9
2-3 Monitor Connection to System Unit	2-13
2-4 Connection to Power Source, Color Monitor	2-17
2-5 System Connection to a DELNI	2-20

3-1	Controls and Indicators	3-2
3-2	The CPU Distribution Panel	3-3
3-3	Front and Side Controls, Color Monitor	3-11
3-4	Rear Controls and Connectors, Color Monitor	3-12
4-1	The LN03	4-3
4-2	The PrintServer 40 (LP540)	4-5
4-3	The LA210	4-6
4-4	The LA75	4-8
4-5	The LA50	4-9
4-6	Printer and Plotter Connection to the System	4-12
4-7	The Tablet	4-13
4-8	Connectors	4-20
4-9	DIGITAL ThinWire Ethernet Station Adapter (DESTA)	4-21
5-1	System Circuit Breaker	5-3
5-2	Fuse Location, Color Monitor	5-11

Tables

3-1	Normal Power-On Indications	3-9
3-2	Tape Drive Controls and Indicators	3-17
4-1	Optional Storage Devices	4-16
5-1	System Unit Troubleshooting Procedures	5-3
5-2	Fixed Disk and Diskette Drives Troubleshooting Procedures	5-6
5-3	Tape Drive Troubleshooting Procedures	5-7
5-4	Monitor Troubleshooting Procedures	5-8
5-5	Pointing Device Troubleshooting Procedures	5-10
A-1	System Electrical Requirements	A-1
A-2	System Environmental Requirements	A-2
A-3	Color Monitor Specifications	A-2
A-4	Mouse Specifications	A-4
A-5	Tablet Specifications	A-5
A-6	RD53 Fixed Disk Drive Specifications	A-7
A-7	RD54 Fixed Disk Drive Specifications	A-8
A-8	RX50 Dual Diskette Drive Specifications	A-8
A-9	TK50 Tape Drive Specifications	A-9

Preface

This manual describes how to install, operate, and troubleshoot the VAXstation II/GPX (Graphics Processing Extension) in the BA123 enclosure. DIGITAL recommends that you read this manual before you install your system. If you experience system problems, use this manual to isolate the error before seeking help from service personnel.

Description of the VAXstation II/GPX

The VAXstation II/GPX is a stand-alone, 32-bit workstation based on the MicroVAX II processor. The system comes with up to 16 megabytes of memory, a video subsystem module, and an Ethernet communications module. Other system components include a 47.5-centimeter (19-inch) diagonal color monitor on a tilt-swivel base, a mouse or tablet, and a keyboard. You may have one or more of the following storage options: a tape drive, diskette drive, or fixed-disk drive.

The video subsystem, based on a VLSI (Very Large Scale Integration) graphics coprocessor, off-loads the MicroVAX II main processor from computation-intensive graphics tasks. The system allows parallel processing in multiple planes so that no degradation in performance occurs as planes are added.

The 4-plane video subsystem, a 2-module set, can display 16 colors simultaneously. The 8-plane video subsystem, a 3-module set, can display 256 colors simultaneously.

The system unit and peripheral devices can be placed on the floor beside a desk. Hardware options include printers, a tablet, a plotter, memory modules, a video module, disk drive subsystems, a tape drive, a dual diskette drive, a fixed-disk drive, asynchronous multiplexers, synchronous line controllers, a programmable communications controller, and a real-time interface module.

ULTRIX-32m and MicroVMS are the two operating systems offered for the VAXstation II/GPX. Both operating systems offer workstation software, networking software, and a wide range of tools and applications.

Workstation software expands the utility and convenience of the VAXstation II/GPX operating system by providing you with terminals simulated in windows on the monitor screen. Each virtual terminal runs processes independently of processes running in other windows, and the keyboard may be associated with any window at any time. Various software tools allow you to create windows and graphics from a program level. Your workstation software documentation contains additional information on your system and optional hardware.

Using the mouse or the tablet to move a pointer, you can view or manage a variety of activities at once. For example, you can do the following:

- Examine a compilation listing while editing the source file
- Read notices without exiting from a program
- Start one task and follow its progress while interacting with another task
- Send mail without exiting an editing session
- Log on to a remote VAX host to run tasks requiring intensive computation
- Print a list of files on your printer while creating other files (requires the printer option)

Conventions Used in This Document

The following conventions are used in this document:

Convention	Meaning
Bold	VAXstation II/GPX system controls and indicators are highlighted in bold lettering.
"Quotes"	Diagnostic media titles and tests appear in quotations.
<i>Italics</i>	Computer terms defined in the Glossary are italicized the first time the word appears in the text, beginning with Chapter 1.

Structure of This Document

The manual is divided into six parts:

Part I: Base System Installation

This part describes how to unpack, install, and test the VAXstation II/GPX.

- **Chapter 1** describes preinstallation procedures, including checking the shipment components and ensuring adequate site preparation.
- **Chapter 2** describes how to set up, connect, and test the system components.

Part II: Operation

This part describes how to operate the VAXstation II/GPX.

- **Chapter 3** describes the system controls and indicators.

Part III: Options

This part describes the hardware options for the VAXstation II/GPX and gives installation information where applicable.

- **Chapter 4** describes hard-copy output devices, input device, memory, video devices, disk storage devices, and communications devices. The chapter provides installation information for these options.

Part IV: Troubleshooting

This part describes how to isolate a problem and decide what to do next.

- **Chapter 5** explains basic troubleshooting procedures, power-up messages, and the maintenance system for the VAXstation II/GPX.
- **Chapter 6** describes how to call DIGITAL for help.

Part V: Appendixes

- **Appendix A** provides VAXstation II/GPX system specifications.
- **Appendix B** lists related documents.

Part VI: Glossary

The glossary defines computer terms that are italicized at first use in the text as well as other common computer terms.

Intended Audience

This manual is designed for users with little or no experience installing and using both software and hardware.

Chapter 1

Preparing for Installation

Figure 1-1: A VAXstation II/GPX in the BA123 Enclosure

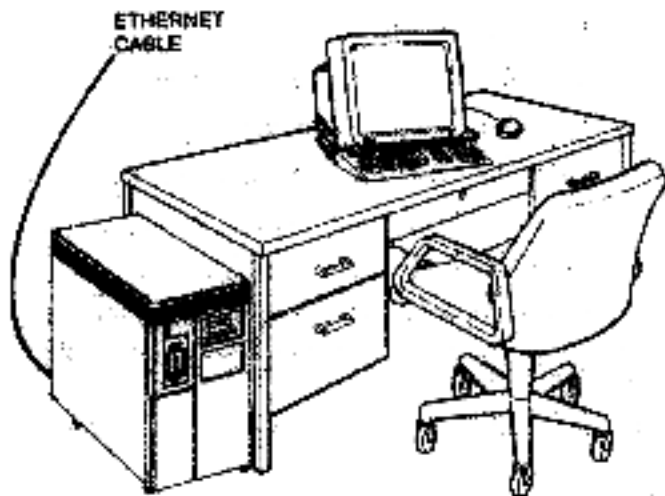

MLC-W145

Check Your Shipment

Unpack the VAXstation II/GPX system and check your shipment against the packing list on the outside of one of the boxes.

WARNING: Because of the weight of the system unit and monitor, you need two people to perform this procedure.

Your basic shipment consists of three cartons:

1. The VAXstation II/GPX system unit carton contains the following materials:
 - Accessories Kit, containing:
 - Installation and testing accessories, including a flat screwdriver, a Phillips screwdriver, label sheets, and a grant card (for use by your support personnel)
 - System unit power cord, loopback connectors, and BNE3x transceiver cable
 - BC18Z video cable assembly
 - VAXstation II/GPX system unit (BA123 enclosure)
2. Hardware Support Kit (Z4A4B), containing:
 - VAXstation II/GPX Hardware Information binder, housing:
VAXstation II/GPX Owner's Manual, BA123 Enclosure (this manual)
VCB02 Video Subsystem Technical Manual
 - For systems with TK50s or RX50s: appropriate media for testing and troubleshooting (Z4A4B-C5 contains TK50 tape cartridges; Z4A4B-C3 contains RX50 diskettes.)
3. The VAXstation II/GPX consolidation carton contains the following components:
 - Graphics monitor with installation documentation
 - Monitor power cord
 - LK201 keyboard with cable, feet for the keyboard, and an extra power cord
 - VSXXX-AA mouse or tablet with cable

NOTE: You must order the keyboard and mouse or tablet separately from the rest of the workstation components.

If you ordered media and documentation, you receive a software carton for the operating system you selected. The *MicroVMS Workstation Software* carton provides keyboard legend strips in addition to media and documentation.

The software carton also contains the "MicroVAX Diagnostic Monitor" used for functional verification of software operation. It is supplied on either a TK50 tape cartridge or an RX50 diskette as you selected, based on your system configuration.

If additional options are purchased at a later date, a new copy of the "MicroVAX Diagnostic Monitor" may need to be ordered.

NOTE: *If you have a diskless system that contains neither a tape drive nor a diskette drive, contact your service representative for verification of system operation.*

Check for optional items that you might have ordered, such as additional software or a printer. Refer to the order sheet or packing list on the outside of the cartons.

If your shipment is damaged, or if any item is missing, inform the delivery agent and contact your sales representative.

NOTE: *Save all boxes and packing material in case you need to send back parts of the system for repair, or if you change work locations.*

Site-Preparation Review

Before installing your VAXstation II/GPX according to the instructions in the next chapter, review the following preparation requirements:

- Adequate space for the system unit and peripheral devices
- Proper electrical power
- A suitable operating environment

You may wish to review Appendix A, which provides VAXstation II/GPX system specifications, before you proceed with this chapter.

Space Planning

Leave sufficient space around the system unit and monitor to access the units and to allow air circulation through the units.

The System Unit

The vents on the system unit allow proper air flow. Do not block the vents in any way.

The unit weighs 59 kilograms (130 pounds).

Figure 1-2: Dimensions of the System Unit

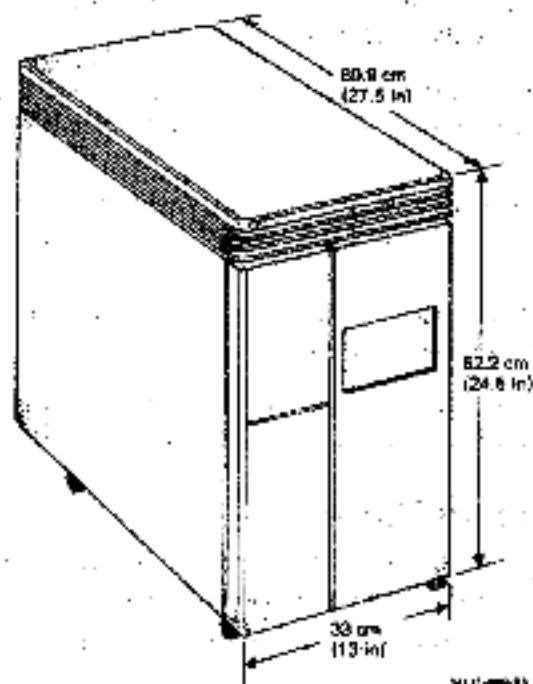

The Color Monitor

The vents on the monitor allow proper air flow. Do not block the vents in any way.

The color monitor weighs 36 kilograms (80 pounds).

Figure 1-3: Dimensions of the Color Monitor

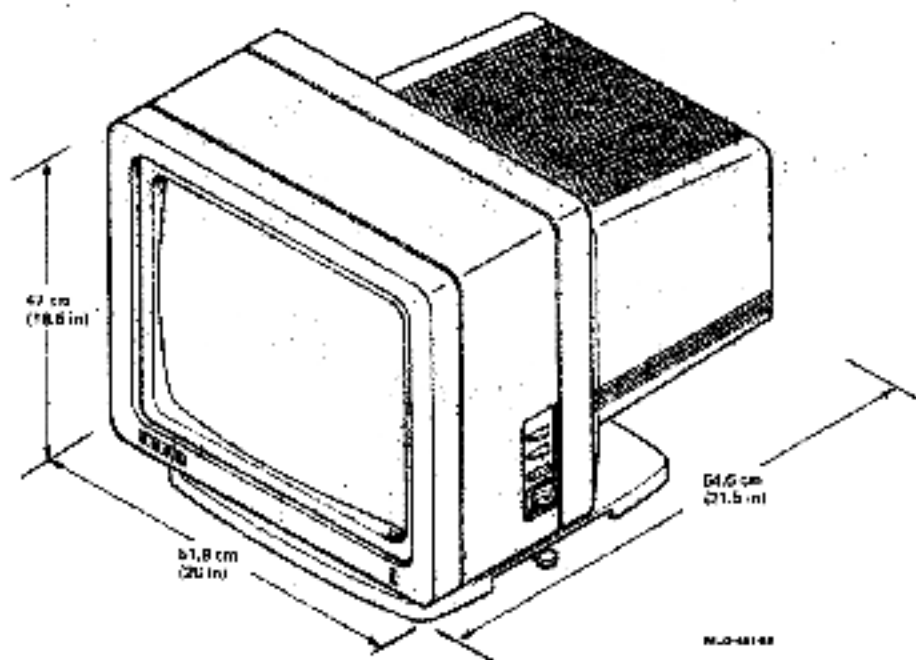

Electrical Requirements

A 20-ampere branch circuit from a power distribution panel is recommended for each system. This circuit must meet national and local standards, provide a good system ground, be stable, and be free from electrical noise. If power disturbances cannot be prevented, add more power-conditioning equipment. Consult service personnel to assess your needs.

The ac power source should supply power to the original system and allow for system expansion. Do not connect other equipment (such as air conditioners, office copiers, or coffee pots) to the circuit dedicated to the system unit or the monitor.

20-AMP DEDICATED BRANCH CIRCUIT - 1 PHASE

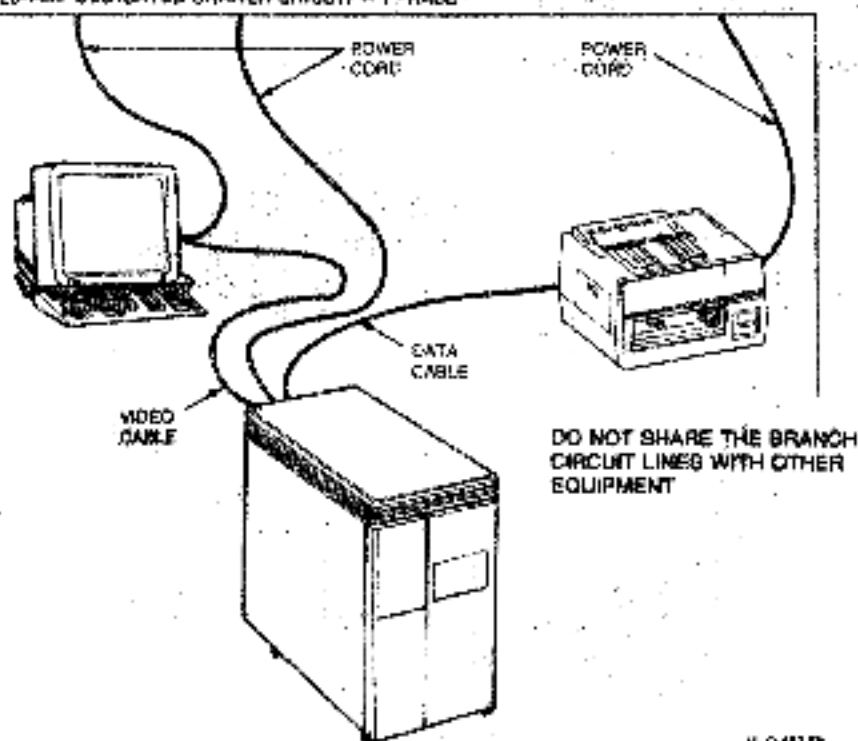

Environment

Temperature and Humidity

The location of the VAXstation II/GPX should have an environmental control system to maintain the recommended temperature and humidity. This system should filter and evenly distribute air to prevent heat from accumulating.

Keep the VAXstation II/GPX away from heaters, photocopiers, or direct sunlight.

Static Electricity

Static electricity can cause a system to fail, *data* to be lost, and other problems to occur. The most common source of static electricity is the movement of people in contact with carpets and clothing. Low humidity causes the greatest buildup of static electricity. The following precautions reduce static buildup:

- Maintain greater than 40% relative humidity.
- Locate the system away from busy areas, such as office corridors.
- If a carpet is already fitted at the selected location, place antistatic pads under the system.

Clean Area

Dust particles can clog air passages inside the equipment, thus reducing the cooling air flow and diskette life, especially if the particles are abrasive. Keeping the system area clean and free from dust helps reduce these effects.

Do not place food or liquid on the system.

Supplies Storage

Store supplies, such as diskettes, at the same temperature and humidity levels as recommended for the system.

1. The first part of the document discusses the importance of maintaining accurate records of all transactions. It emphasizes that proper record-keeping is essential for the integrity of the financial system and for the ability to detect and prevent fraud.

2. The second part of the document outlines the specific requirements for record-keeping, including the need to maintain original documents and to keep copies of all transactions. It also discusses the importance of regular audits and the need to ensure that all records are up-to-date and accurate.

3. The third part of the document discusses the role of the auditor in ensuring the accuracy of the records. It emphasizes that the auditor must be independent and objective and must have the necessary qualifications and experience to perform the audit.

4. The fourth part of the document discusses the consequences of failing to maintain accurate records. It notes that failure to do so can result in the loss of the company's ability to raise capital and can also result in the company being subject to legal action.

5. The fifth part of the document discusses the importance of transparency and the need to provide accurate information to investors and other stakeholders. It notes that transparency is essential for the success of the company and for the confidence of the market.

Chapter 2

Setting Up the Hardware

This chapter describes how to assemble, connect, and test the VAXstation II/GPX. You should have already unpacked the system as described in Chapter 1.

CAUTION: *When connecting any component of the VAXstation II/GPX system, set all power switches to the 0 (off) position.*

WARNING: *Because of the weight of the system unit and monitor, you will need two people to perform this procedure.*

Make sure your system unit's location meets the site-preparation requirements in Chapter 1. To install the VAXstation II/GPX system, follow the steps as directed in this chapter. If you have trouble:

- Refer to Chapter 5 for troubleshooting information.
- Refer to Chapter 6 for service information.

The following section explains how to set up the color monitor.

Setting Up the Color Monitor

1. Make sure the monitor power switch is set to 0 (off).

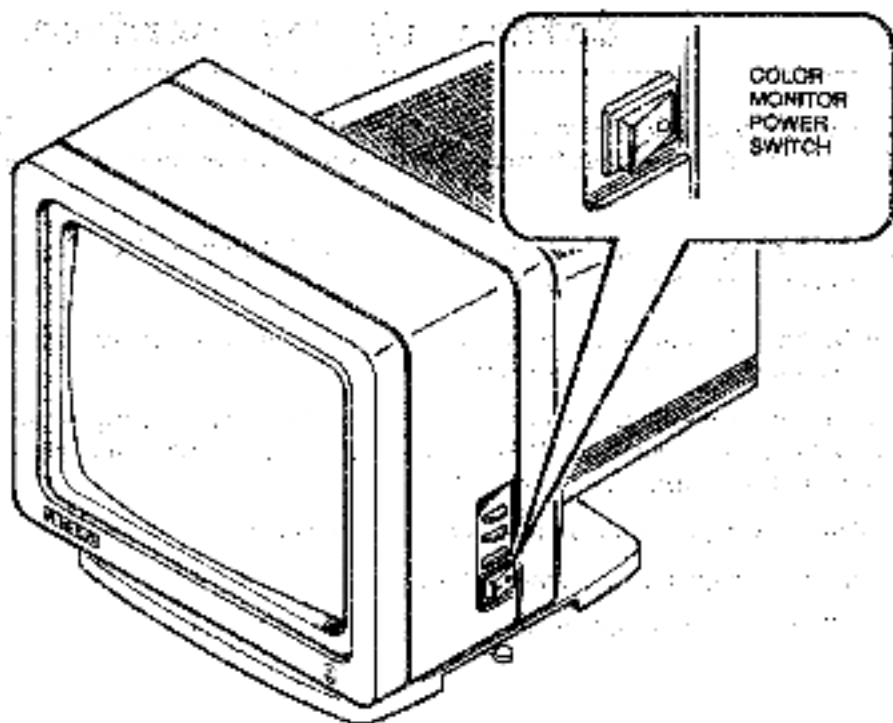

M10.000.05

2. Place the monitor on a level surface. Position the monitor for ease of use.

NOTE: Make sure the tilt-lock lever is on the right when you face the monitor.

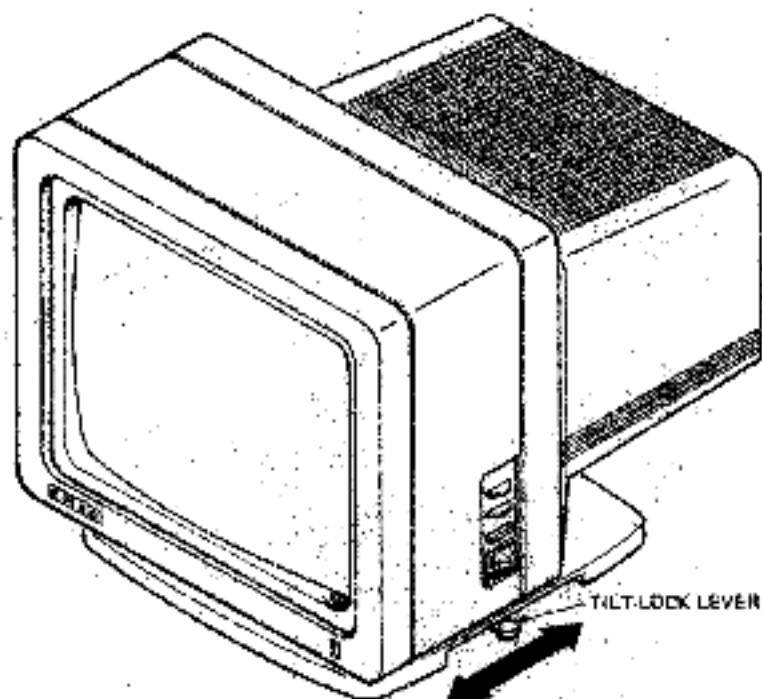

MS-DOS 3.31

3. Adjust the monitor to a position you find comfortable. To tilt the monitor, perform the following steps:
 - a. Slide the tilt-lock lever away from you (toward the back of the monitor) to unlock the monitor from the base.
 - b. Tilt the monitor to the desired position.
 - c. Slide the lever toward you to lock the monitor in place.

4. Locate the BC18Z video cable assembly from the system unit carton. Plug the ends of the R, G, and B video cables into the corresponding R, G, and B sockets on the back of the monitor. Turn each connector clockwise to fasten.

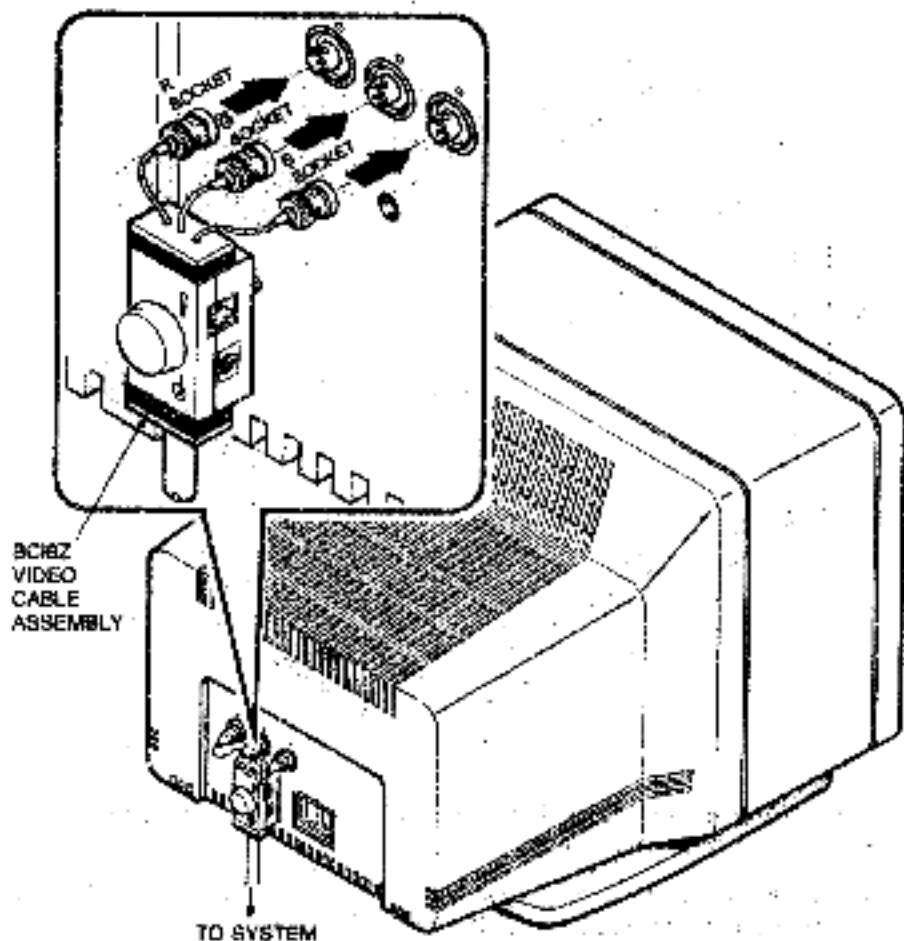

5. Screw the video cable assembly knob clockwise into the monitor.

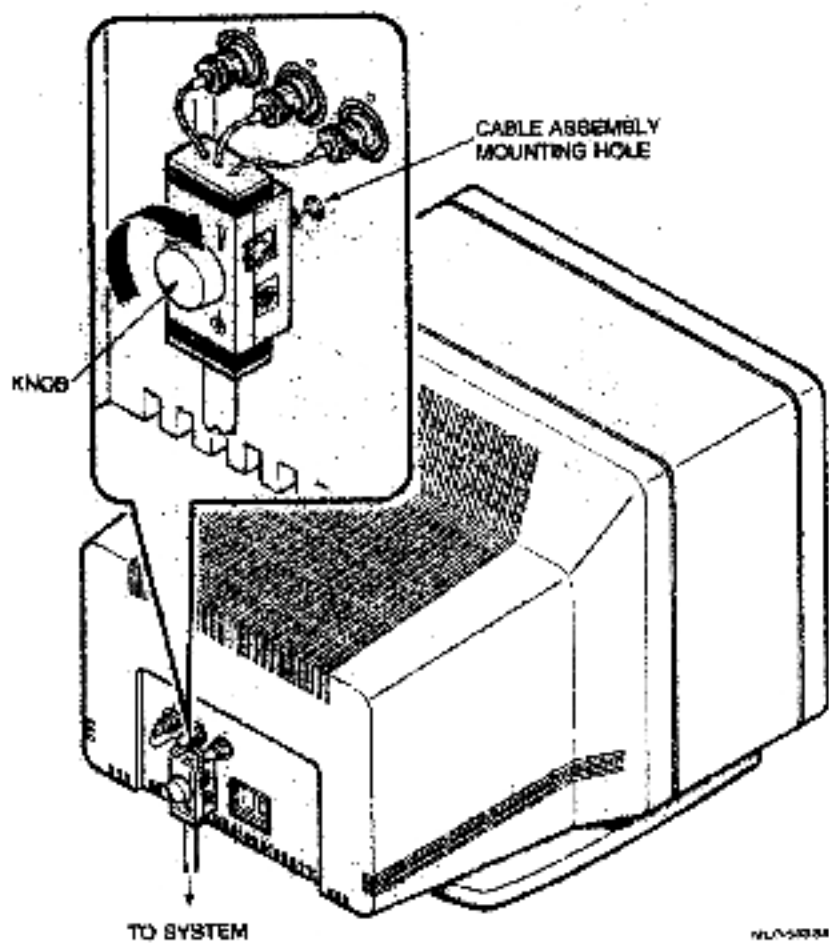

Setting Up the Keyboard and Pointing Device

1. Install the keyboard feet.

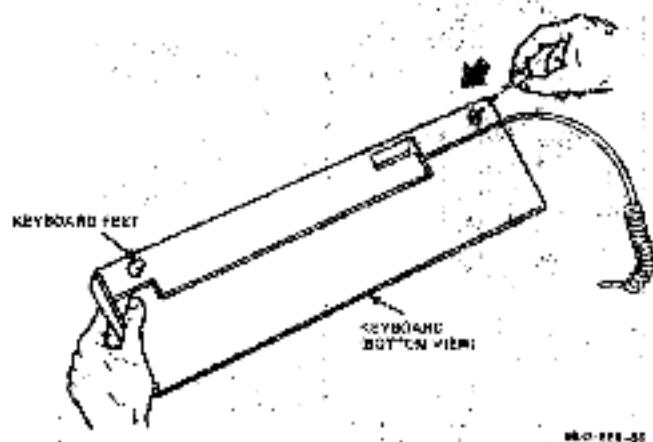

2. Connect the keyboard cable to the video cable assembly.

Figure 2-1: Keyboard Connection, Color Monitor

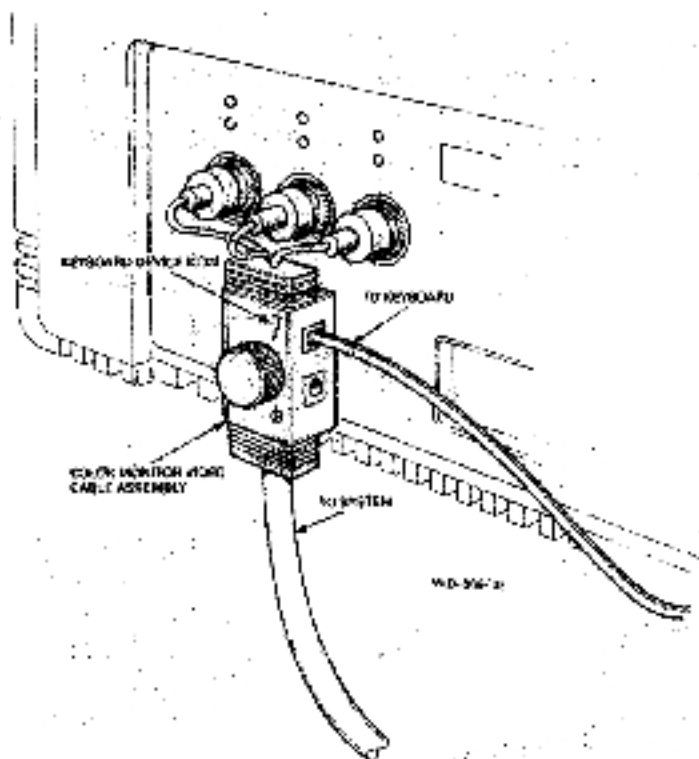

3. Locate the pointing device you wish to use, which may be either a mouse or a tablet with a puck or stylus. Both devices cannot be used at the same time.
4. Plug the pointing device cable into the video cable assembly.

NOTE: Attach the puck or stylus before connecting the tablet to the VAXstation II/GPX. The instruction sheet that comes with the tablet explains how to connect the various components. Save this sheet for future reference. To change the puck or stylus, first disconnect the tablet from the VAXstation II/GPX, then swap the puck or stylus, and reconnect the tablet to the system.

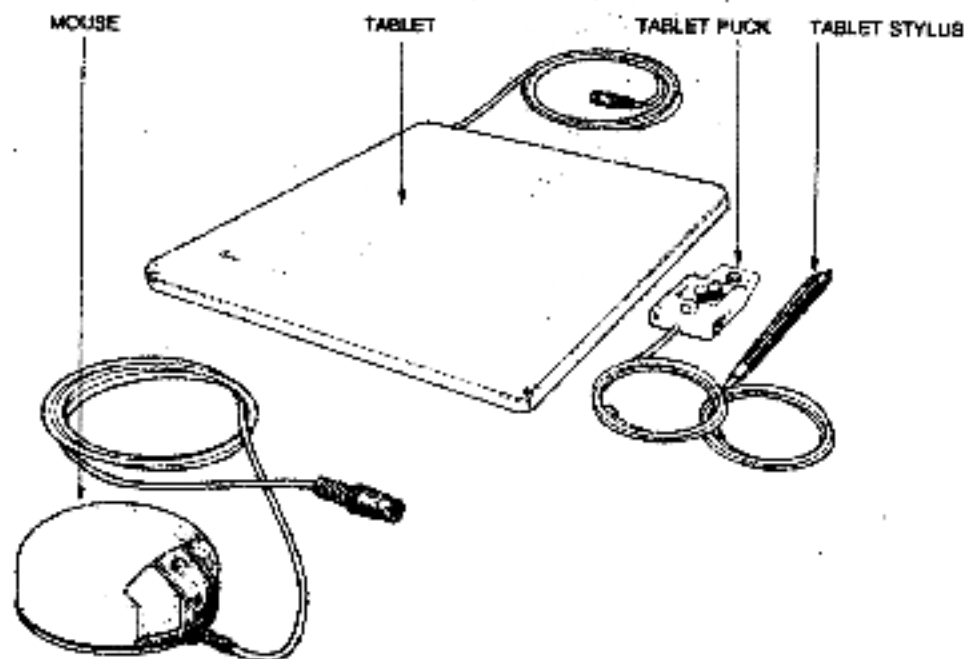

VLD-108410P

Figure 2-2: Pointing Device Connection, Color Monitor

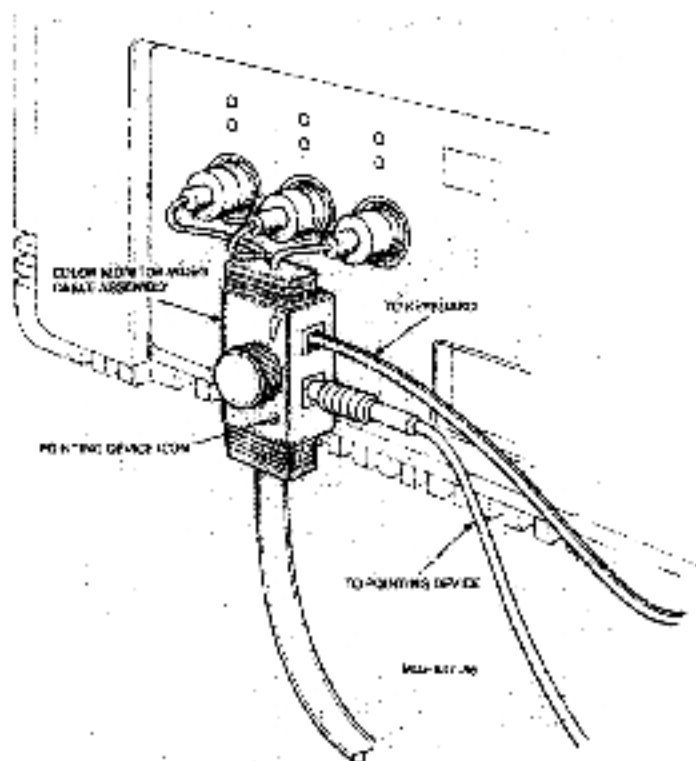

Connecting the VAXstation II/GPX to a Power Source

1. Make sure that all pushbuttons on the *control panel* of the system unit are in the out position.

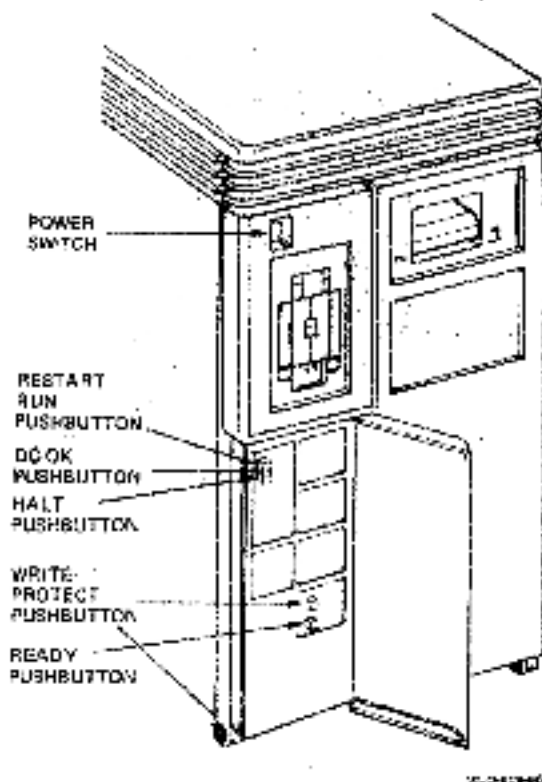

2. Locate the labels sheet in the Accessories Kit of your shipment.
3. Put the appropriate label on the control panel, as shown above.
4. If your unit contains *diskette drives*, label the left drive 1 and the right drive 2.

5. Open the back door of your system unit by pulling out the left side. A pop fastener holds the door in place.

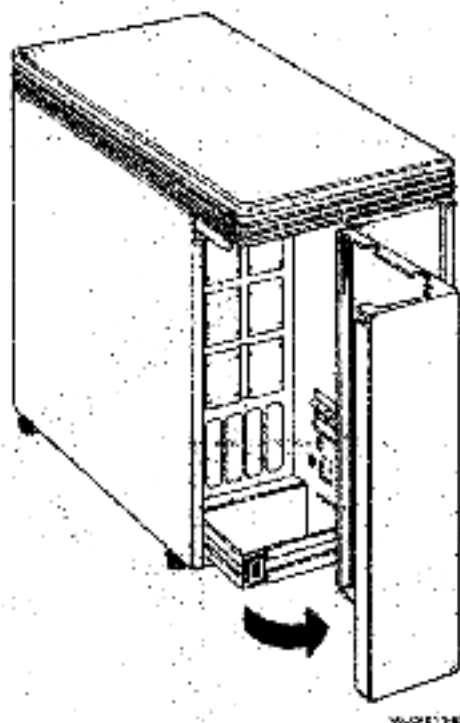

6. Set the controls located on the CPU distribution panel insert on the back of the system unit to the following positions:
- **Halt Enable/Disable** switch to the disable position (down)
 - **Mode** switch to the middle (language inquiry) position
 - **System Unit baud rate** at 4800 baud

NOTE: The panel uses international symbols rather than text. Use the illustration as a guide.

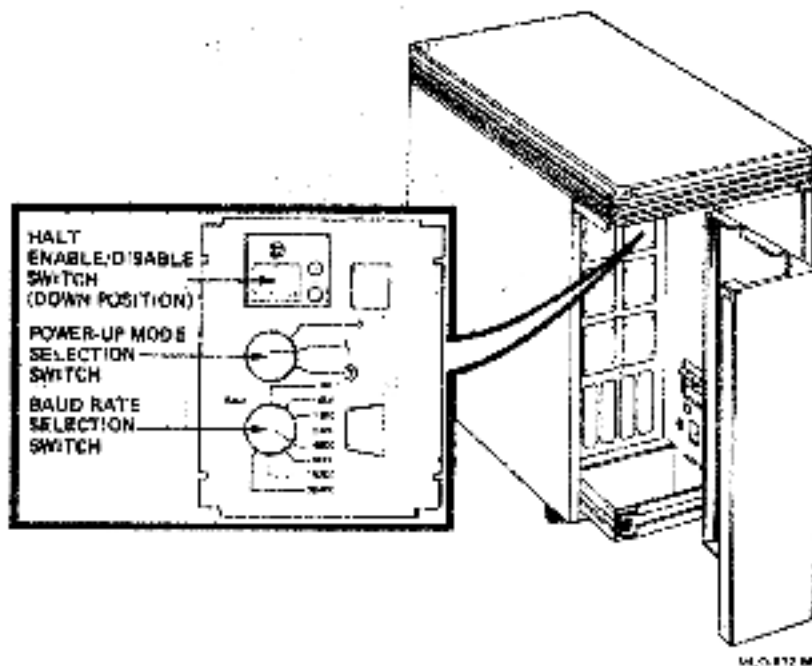

7. Connect the free end of the color monitor video cable to the back of the system unit as illustrated.

Figure 2-3: Monitor Connection to System Unit

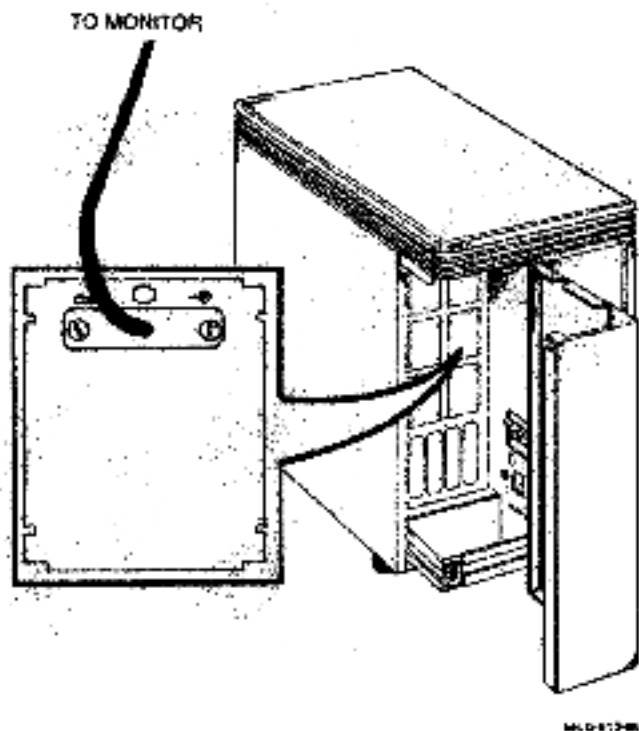

8. Install and connect any uninstalled options. Option modules ordered with your initial system order come preinstalled.
- Connect additional devices in any order.
 - Read Chapter 4 for descriptions of the options and installation information.
 - Also refer to the documentation included with additional devices.

9. Locate the monitor and system unit power cords. The two cords are the same type and interchangeable. Ensure that the plugs fit the wall outlet.

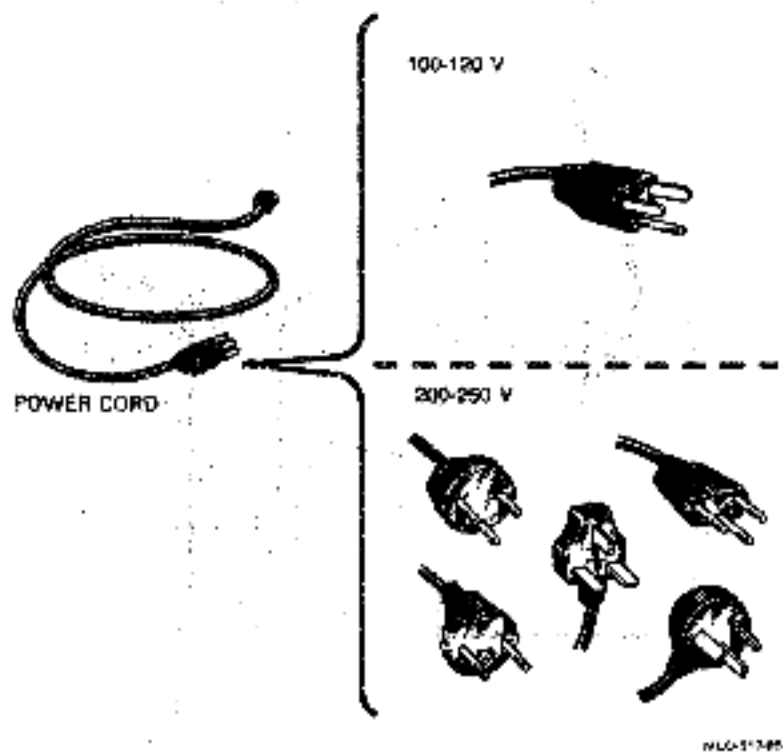

10. Read and remove the label covering the power connector of the system unit.
11. Check the **voltage switch** setting of the system unit. If necessary, change the switch setting to match the voltage source. To change the setting, use a pen or screwdriver to move the switch to the correct position.

CAUTION: An incorrect voltage switch setting will damage the VAXstation II/GPX system.

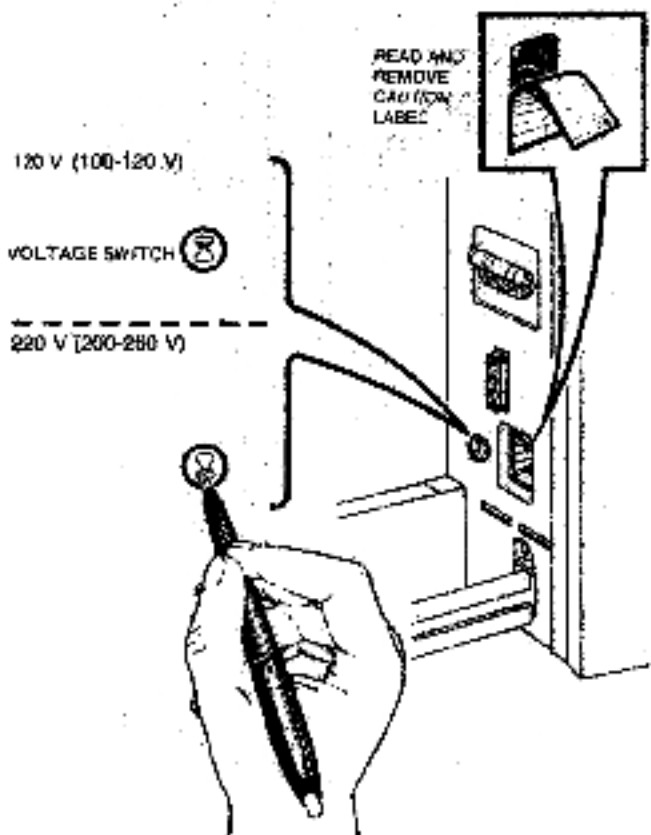

HEU-01962

12. Before you connect the VAXstation II/GPX to a power source, make sure that the monitor **power switch** is set to 0 (off), the pushbuttons on the system unit front control panel are out, and the **power switch** on the system unit front control panel is set to 0 (off). The **power switch** is located on the front of the VAXstation II/GPX system unit in the following illustration.

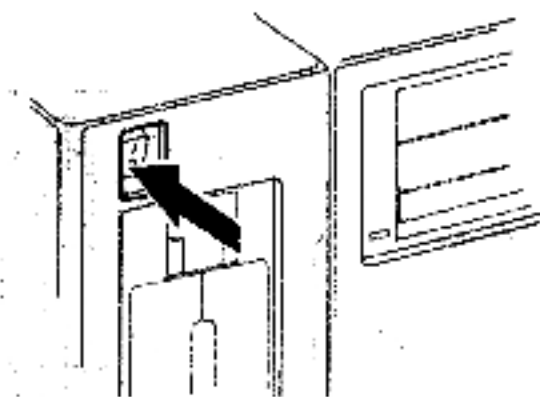

ML051948

13. Connect the monitor power cord to the monitor first and then to an outlet.

Figure 2-4: Connection to Power Source, Color Monitor

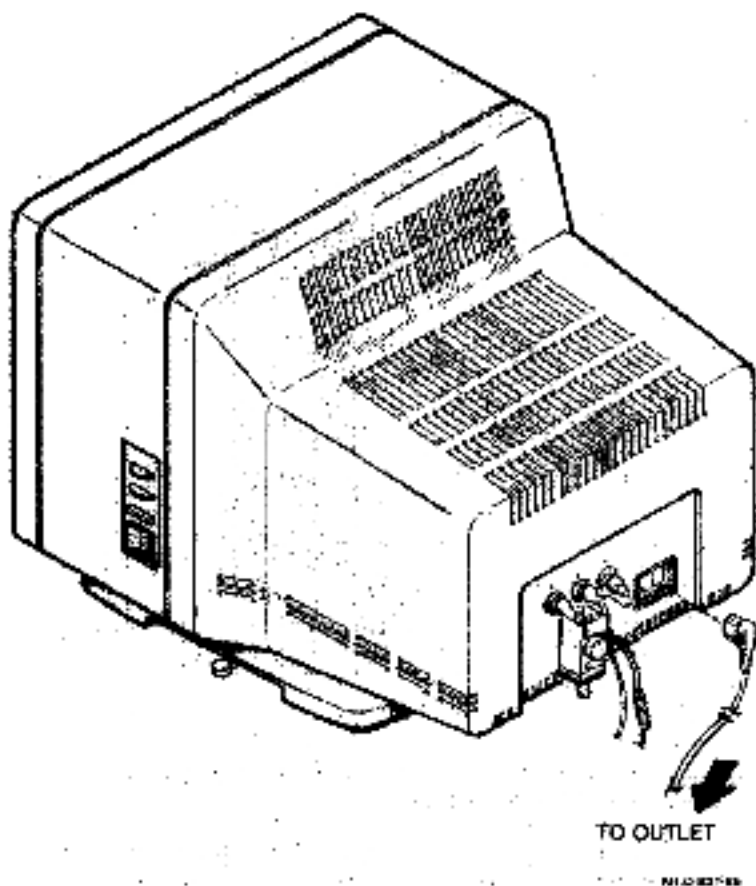

14. Plug in the ends of the system power cable.
- Thread the cable through the system cable guide and plug one end firmly into the system unit power connector.
 - Insert the other end of the system power cable into the wall receptacle.

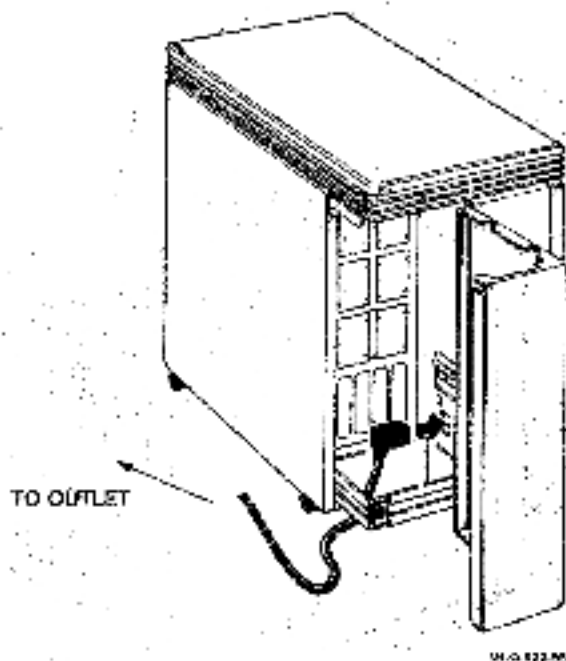

Run the power and other cables in areas where no one will trip over them. Avoid straining or bending the cables.

Leave the back door of the system unit open. You will be instructed to close it in the section entitled Testing the VAXstation II/GPX in this chapter.

Connecting the VAXstation II/GPX to a Network

You can connect your workstation to either a standard or ThinWire Ethernet network.

NOTE: For a more detailed description of networking, consult the *DECconnect System Guides*.

Connecting the Ethernet Transceiver Cable to the Workstation

To connect a transceiver cable to the VAXstation II/GPX:

1. Set the system unit power switch to 0 (off).
2. Attach the BNE3x transceiver cable to the back of the system unit, routing the cable through the cable guide slot.

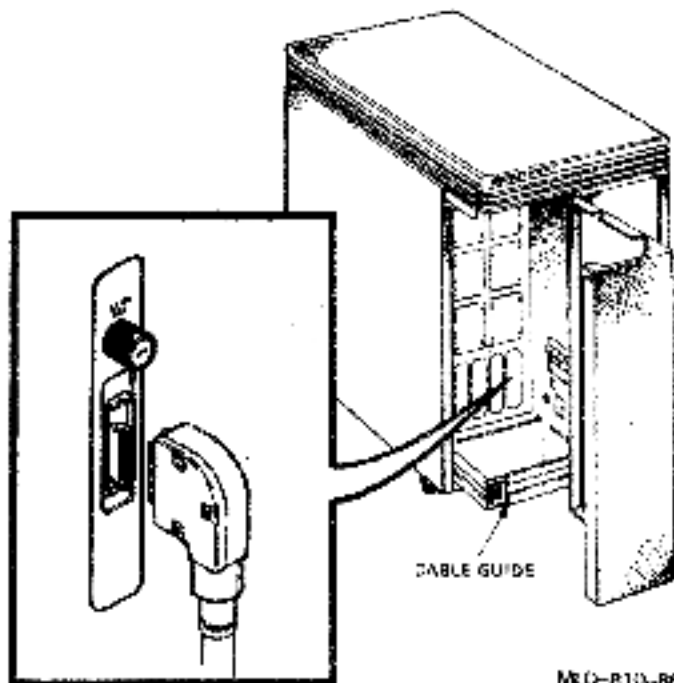

ML0-B10-88

You can connect the other end of the cable to a DELNI or DESTA or have your service representative connect your system to an H4000 transceiver port.

Connecting to Standard Ethernet

To connect the VAXstation II/GPX to a DELNI, plug the female end of the BNE3x cable into a free port of the DELNI.

Figure 2-5: System Connection to a DELNI

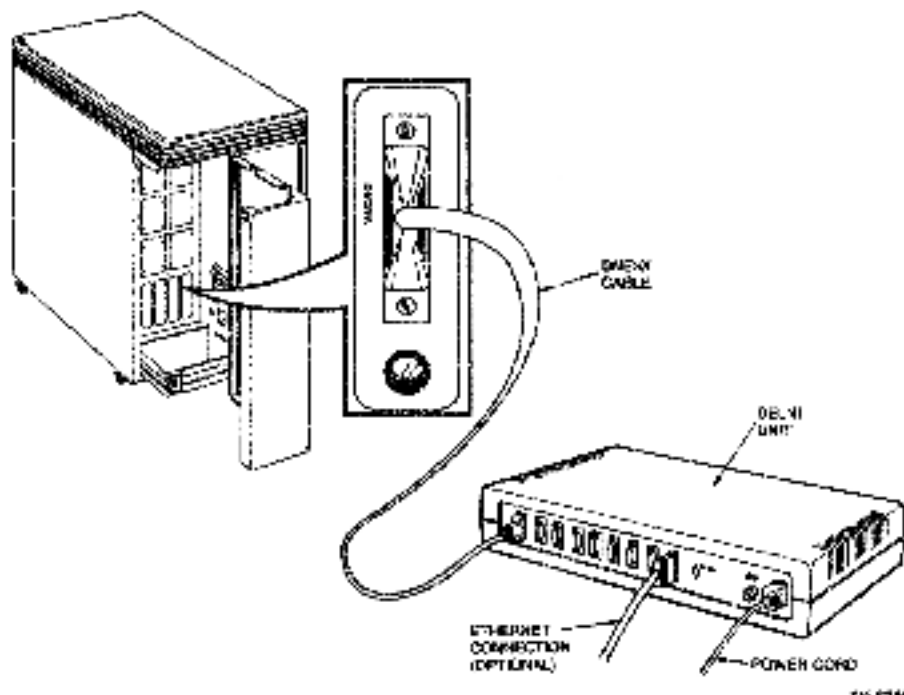

NOTE: To communicate over an Ethernet network, you must install communication software supported by your operating system.

Contact your service representative to connect your system to an H4000 transceiver port.

See Chapter 4 for more information on the DELNI and DESTA.

Connecting to ThinWire Ethernet Using the DESTA

1. Attach ThinWire cable to one side of the T-connector as shown in the following illustration.

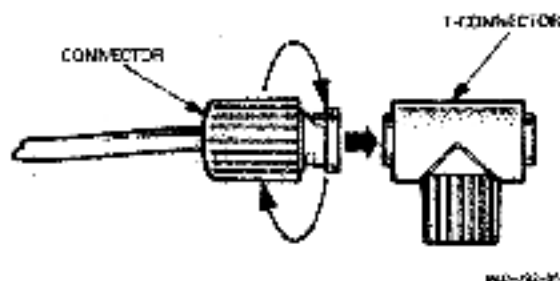

2. If the system is the first or last system in a single ThinWire segment, attach a terminator to the side of the T-connector not connected to the ThinWire cable as shown in the following illustration.

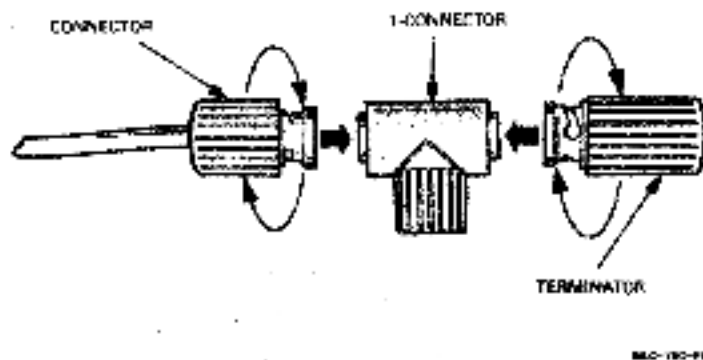

3. If the system is not the first or last system and you want to connect another system to the ThinWire cable, do not attach a terminator to the T-connector. Add another section of ThinWire cable to the T-connector as shown in the following illustration.

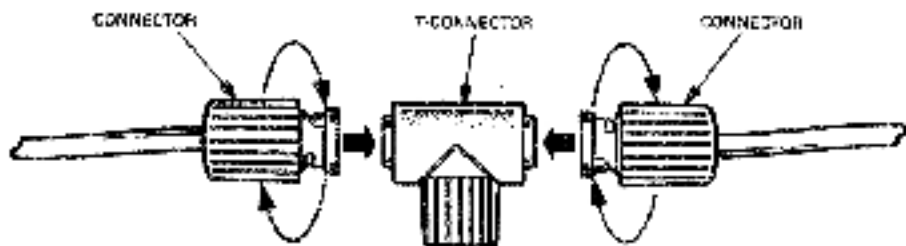

9-20781-00

4. Attach the T-connector to the DESTA's connector.

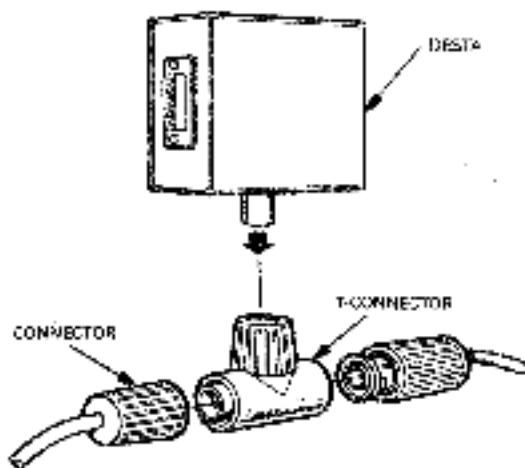

9-20781-00

5. Attach the 15-pin connector on the transceiver cable to the DESTA.

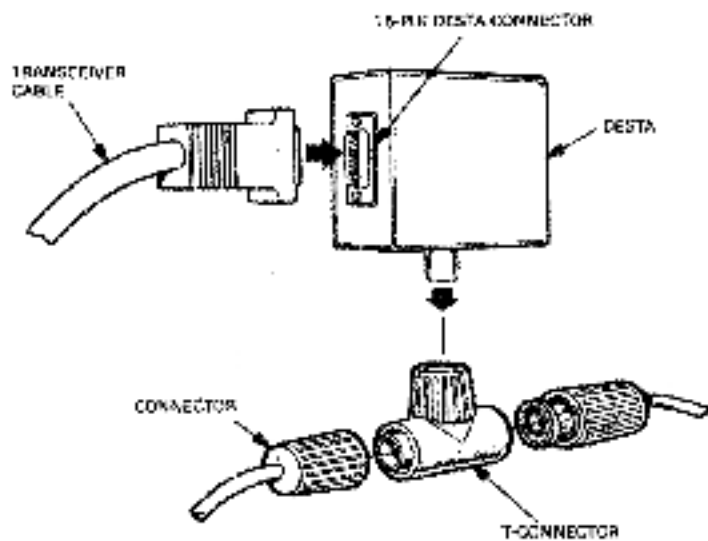

17-174-10

Testing the VAXstation II/GPX

The first time you *power up* your system, check the various components of your system. If you have neither a *tape drive* nor a *diskette drive*, contact your service representative for testing of your system. If you have either a tape or diskette drive, follow these steps:

1. If you have a fixed disk, push the **Fixed Disk Ready** pushbutton on the control panel to put the fixed disk *off-line*.

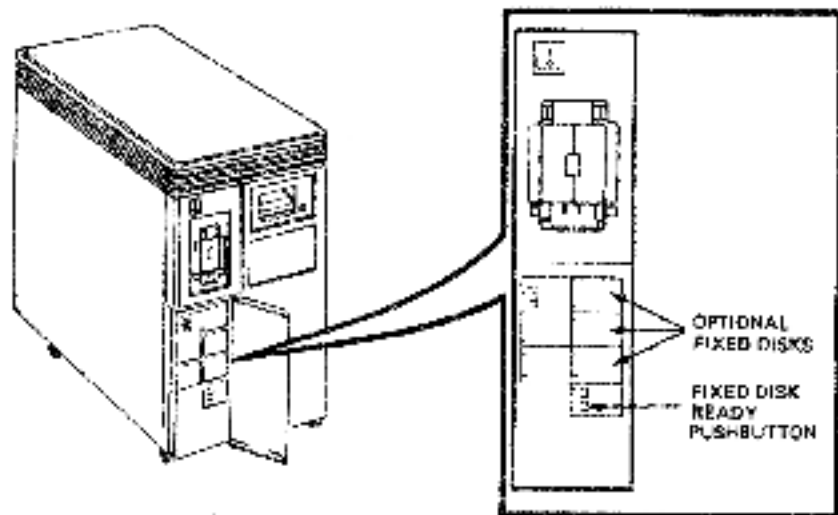

010-22825

2. Power up the monitor by setting the monitor **power switch** to 1 (on).

NOTE: After setting the system power switch to 1 (on), the monitor displays the language selection menu. Ignore the data on this screen until you have inserted the diagnostic medium as directed by this manual. If the video display does not appear in about 30 seconds, refer to Chapter 5.

3. Power up the VAXstation II/GPX by setting the system unit **power switch** to 1 (on).

You may use either a TK50 tape drive or an RX50 diskette drive to load diagnostics into your system. Your system can contain both types of load devices.

If you are using a tape drive to load *diagnostics*, proceed to step 4. If you are using a *diskette drive* to load *diagnostics*, proceed to step 6 (skip steps 4 and 5).

4. Find the tape cartridge labeled "MVII Diag. Cust. TK50" in the cartridge holder at the front of this binder.

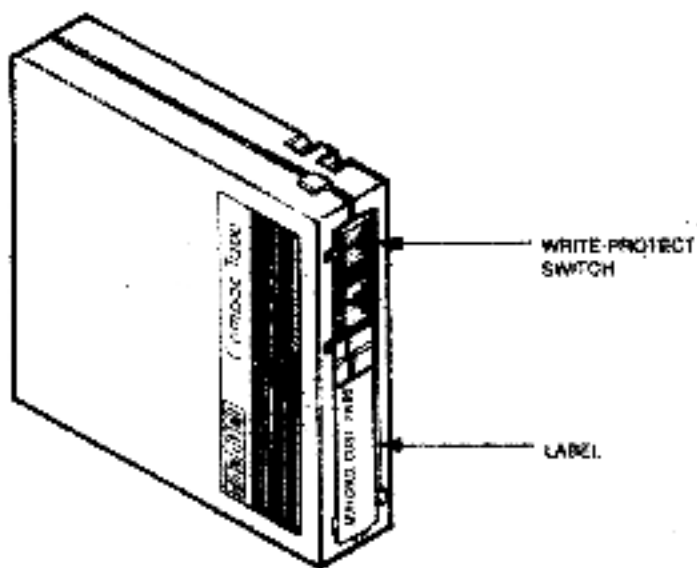

HL0-001-03

5. Insert the tape cartridge into the tape drive by following these steps:
- Make sure you set the system power switch to 1 (on). You cannot move the cartridge release handle if the power switch is set to 0 (off).
 - After the Tape Activity indicator glows green, open the tape drive by lifting the cartridge release handle.
 - With the arrow on the tape cartridge facing up, insert the tape cartridge into the tape drive.

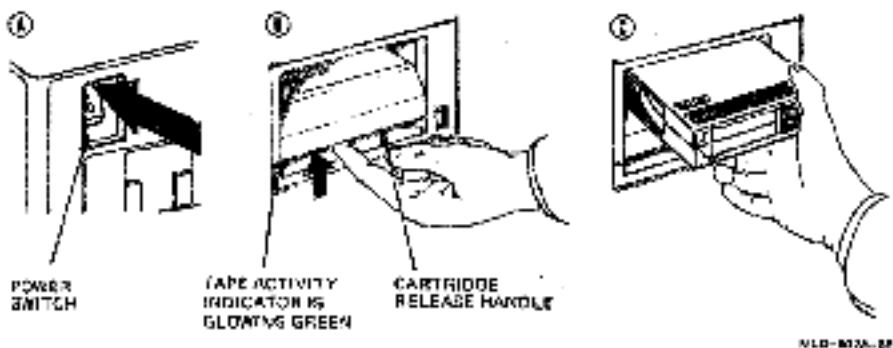

- Push down the cartridge release handle.
- Push in the Load/Unload pushbutton. The pushbutton glows red. When the Tape Activity indicator glows green, the tape is ready for use. Proceed immediately to step 8 (skip steps 6 and 7).

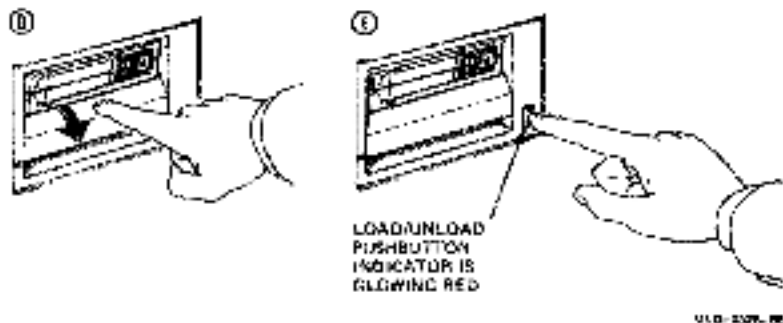

CAUTION: Do not lift the cartridge release handle until the Load/Unload pushbutton extinguishes and the Tape Activity indicator glows green. Do not lift the cartridge release handle while an indicator light flashes.

NOTE: For a more detailed discussion of the TK50 tape drive controls and procedures, refer to Chapter 3.

6. Find the diskettes labeled "MVII Diag. Cust. RX50" in the diskette holder at the front of this binder.

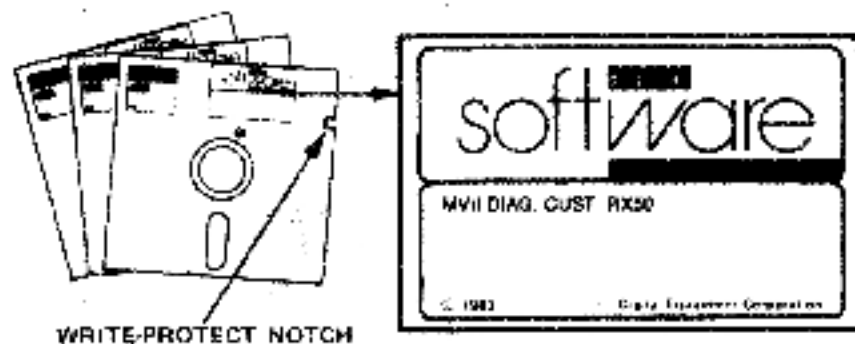

ML0-828-8

7. Insert the diagnostic diskette labeled "#1" by following these steps:
- Open drive 1. The diskette drives contain a cardboard shipping card. Remove the cardboard card prior to diskette insertion.
 - Aligning the orange arrow on the diskette with the orange stripe on the drive, insert the diskette.
 - Close drive 1.

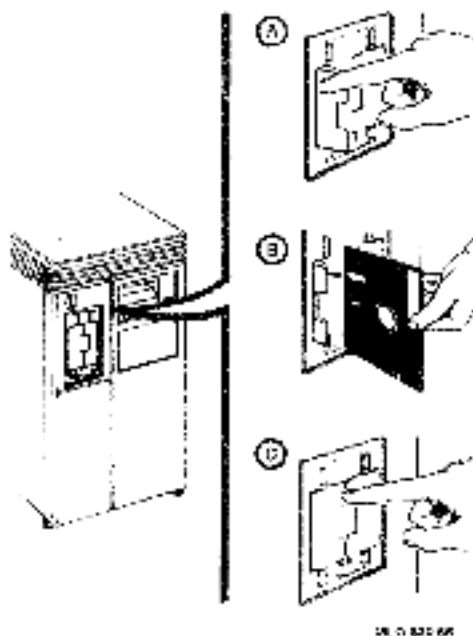

The language selection menu display appears on the monitor screen automatically.

8. From the language selection menu displayed on the monitor, select the language to match your keyboard by pressing the corresponding number key and then pressing RETURN.

KA630-A.V1.2

- | | |
|-------------|---------------|
| 1) Dansk | 7) Nederlands |
| 2) Deutsch | 8) Norsk |
| 3) English | 9) Português |
| 4) Español | 10) Suomi |
| 5) Français | 11) Svenska |
| 6) Italiano | |

(1..11):

MLD-833-85

If you select English, French, or German, a second menu appears. Select which variant of the language you prefer. For example, if you select English, you have the following choices:

- United Kingdom
- United States/Canada

The monitor slowly displays the numbers 7 through 3, indicating completion of steps in the power-up test.

The last part of the display contains the numbers 2 through 0, indicating that the system is loading "MicroVAX Maintenance System" software.

Performing normal system tests.

7..6..5..4..3..

Tests completed.

Loading system software.

2..1..0

NOTE: If you neglected to or took too much time to insert the diagnostic medium, the monitor displays a "254 retry" error message. Insert the diagnostic medium into the load device (if you have not already done so) and press the Restart pushbutton to reboot the system.

After the power-up test finishes, the introductory display of the "MicroVAX Diagnostic Monitor" appears.

MicroVAX Diagnostic Monitor

CONFIDENTIAL DIAGNOSTIC SOFTWARE
PROPERTY OF
DIGITAL EQUIPMENT CORPORATION

Use Authorized Only Pursuant to a Valid Right-to-Use License

Copyright (c) 1987
Digital Equipment Corporation

Current date and time is: 25-Jun-1987 12:30:10

Press the RETURN key to continue
OR enter new date and time, then press the RETURN key.

[DD-MMM-YYYY HH:MM]:

9. Make sure the date and time in the introductory display are accurate. If the date and time are accurate, press RETURN.

If the date and time are inaccurate or not known, type the correct date and time, following the format as shown. An example is 25-JUN-1987 12:30:10. Press RETURN.

The test preparation display informs you that the system is preparing for testing. This process takes a few minutes.

If you have an RX50 diskette drive, text instructs you to remove the diskette labeled "#1" and insert the diskette labeled "#2". The system informs you if additional diskettes are required to complete testing.

NOTE: *If your system does not prompt you for all the diskettes in the diagnostics package, your system configuration does not require the additional diskettes for testing.*

10. When the diagnostics are loaded, text tells you to remove the diskette or tape cartridge and to press RETURN.

The monitor displays the "Diagnostic Monitor Main Menu". Chapter 5 describes each of the options.

NOTE: Do not select a menu choice until this manual directs you to.

MAIN MENU

- 1 - Test the system
- 2 - Show System Configuration and Devices
- 3 - Display the System Utilities Menu
- 4 - Display the Service Menu
- 5 - Exit MicroVAX Diagnostic Monitor

Type the number: then press the RETURN key. >

11. Turn the **Mode** switch counterclockwise on the back of the system unit to the next position to save the language you selected in step 8. Close the back door of the system unit.

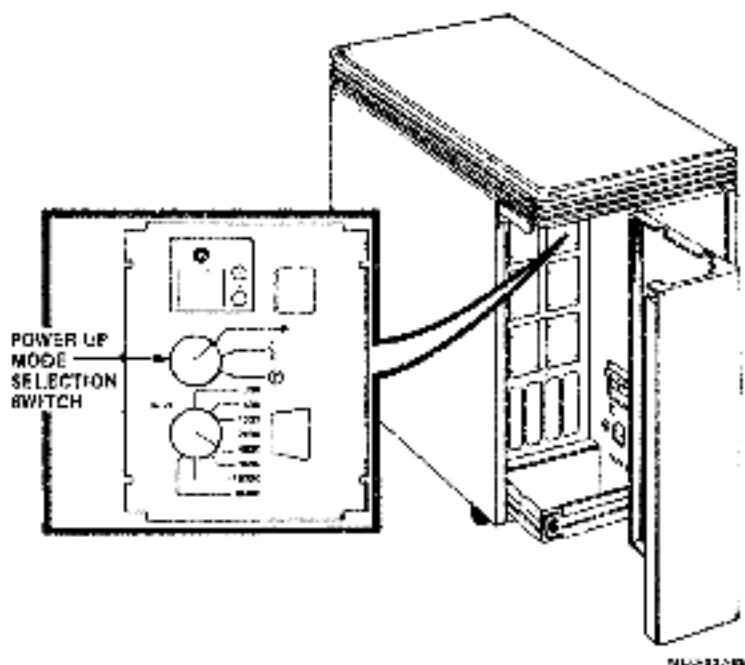

12. Select the "System Test" diagnostic by typing 1 and then pressing RETURN. These diagnostics check the system components.

A few moments later, the monitor displays the "System Test" screen.

MAIN MENU
SYSTEM TEST

This is a test of the MicroVAX computer and its devices.

No additional preparation for this testing is required; the MicroVAX is ready to be tested.

Testing occurs in two parts: The functional tests quickly test each device sequentially; the exerciser test (lasting about 4 minutes) tests how the devices work together.

To halt the test at any time and return to the Main Menu, type CTRL-C by holding down the CTRL key and pressing the C key.

Press the RETURN key to begin testing.

OR type 0 and press the RETURN key to return to the Main Menu. >

13. Press RETURN to begin testing.

The monitor displays several messages to inform you of the progress of the system tests, then the following color bar display appears:

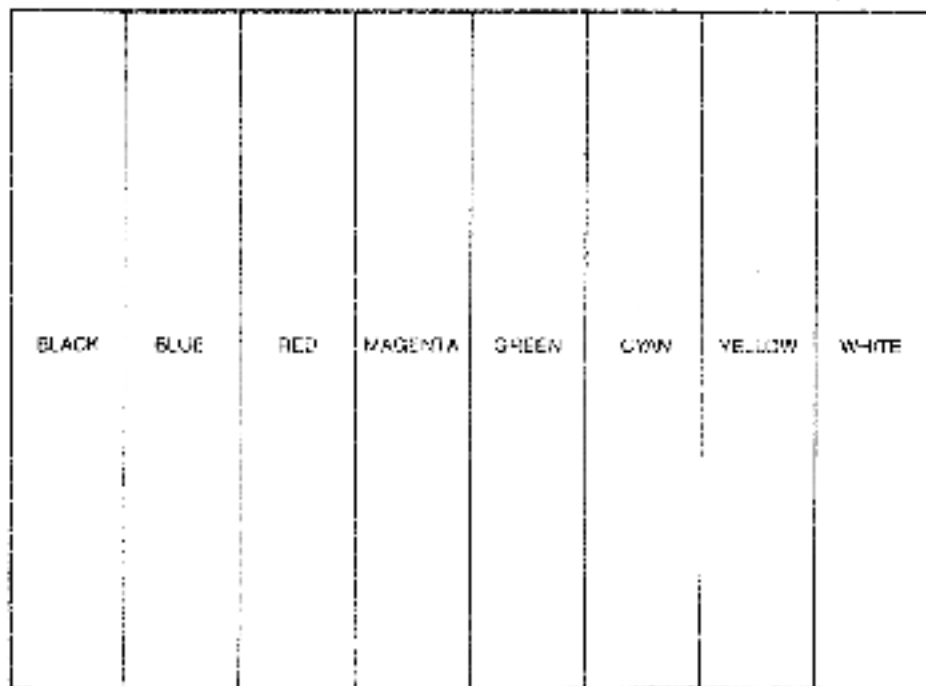

U17-8864-01

After about 4 minutes, a message telling you the system has passed the testing appears on your screen.

SYSTEM TEST PASSED

All devices passed functional tests and the system passed the exerciser test.

At this point you may exit from the MicroVAX Diagnostic Monitor or perform more specialized testing. If you would like additional information, consult the system documentation.

Press the RETURN key to return to the previous menu.

You have successfully installed and tested your VAXstation II/GPX system.

NOTE: *If you see error messages, refer to the troubleshooting section of Chapter 5.*

14. Press RETURN to get back to the "Main Menu". The "Main Menu" shown in step 8 is displayed. Chapter 5 describes the diagnostic tests.
15. Type 5 and press RETURN to exit. The monitor displays the following:

Exiting MicroVAX Diagnostic Monitor

Exit complete. You may now load your system software.

16. If you have a fixed disk, push the Fixed Disk Ready pushbutton on the control panel to put the fixed disk back on-line.

To rewind and unload the TK50 tape cartridge from the tape drive, press the Load/Unload pushbutton to the out position. When the procedure is complete, the Load/Unload pushbutton stops glowing and the Tape Activity indicator glows green. Pull out the cartridge release handle, remove the tape cartridge, and push in the cartridge release handle. See Chapter 3 for more details on this procedure.

You are now ready for software installation. If you are unfamiliar with the system controls and indicators, read Chapter 3, which covers system operation, before installing the software. After you have installed the software, read the rest of this manual.

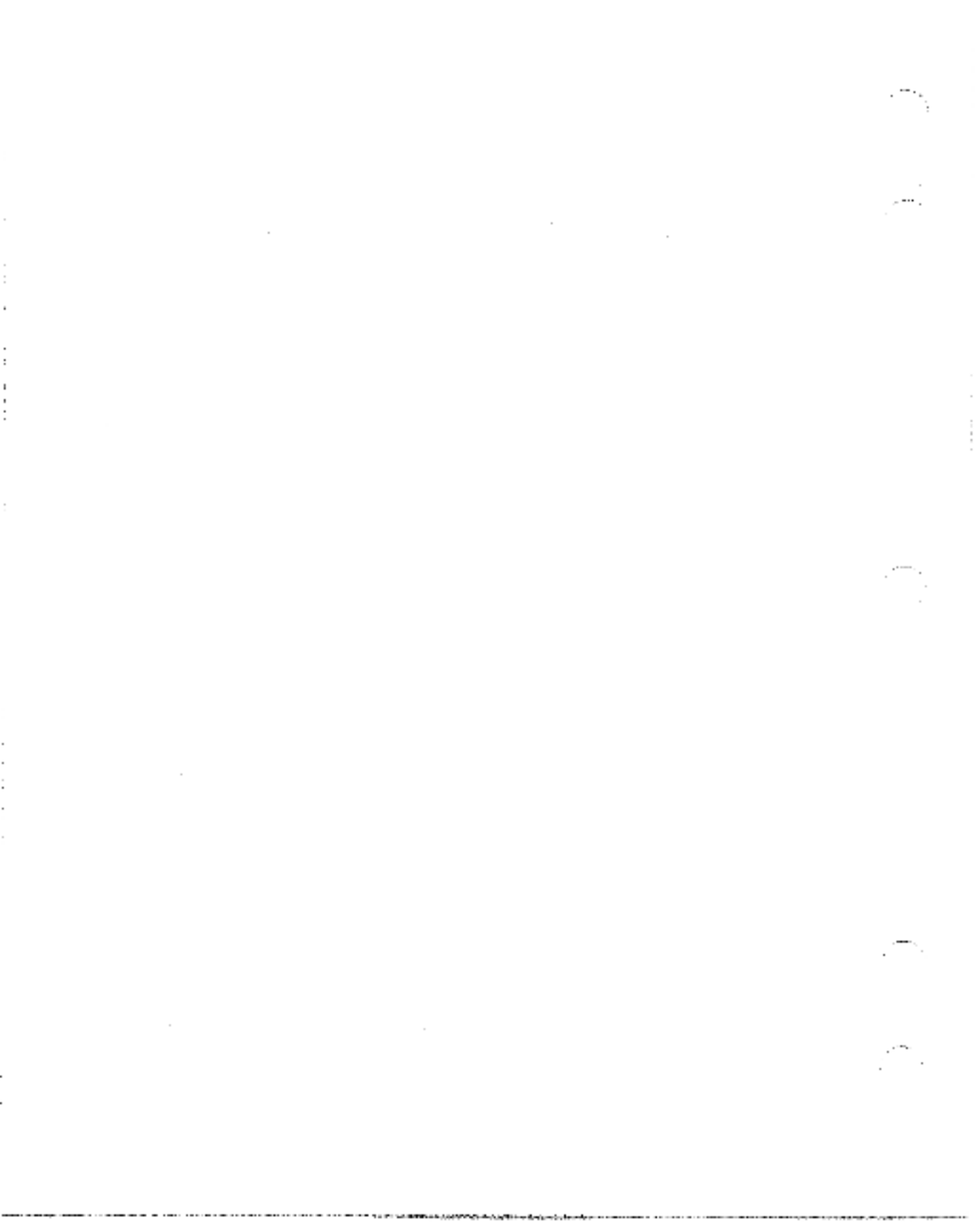

VAXstation II/GPX Hardware

This chapter contains information on the following topics:

- VAXstation II/GPX controls and indicators
- Turning on the VAXstation II/GPX
- Turning off the VAXstation II/GPX
- Color monitor controls and indicators
- Fixed *disk drive*
- Tape drive and tapes
- Dual diskette drive and diskettes
- *Back-up copies*

VAXstation II/GPX Controls and Indicators

The front control panel (Figure 3-1) contains the following controls and indicators:

- System **power switch**
- **Restart/Run** momentary-contact pushbutton
- DC **OK** indicator
- **Halt** pushbutton
- Fixed Disk **Write-protect** pushbutton
- Fixed Disk **Ready** pushbutton

Figure 3-1: Controls and Indicators

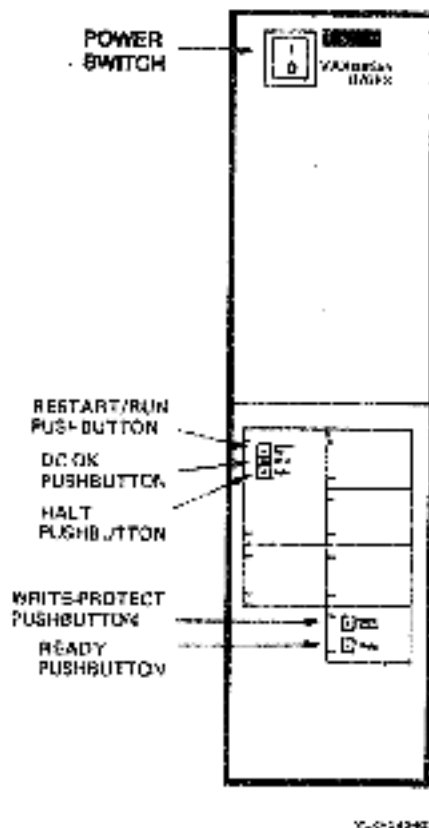

Additional controls and indicators are located on the CPU distribution panel on the back of the VAXstation II/GPX system unit.

Figure 3-2: The CPU Distribution Panel

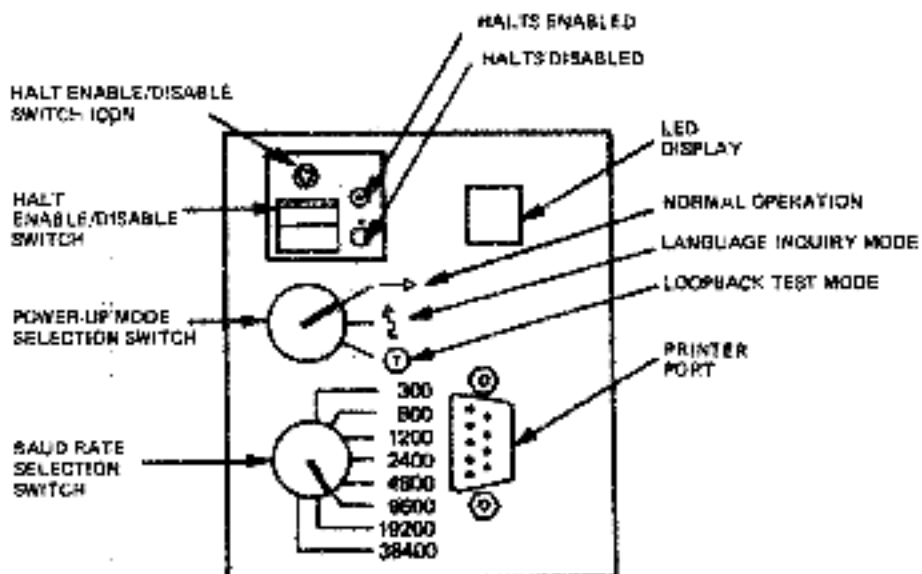

MLO-807-88

The switches, indicator, and connector on the CPU distribution panel provide the following functions:

Halt Enable/Disable Switch (2-position toggle switch)

Switch Position	Function
Up (dot inside circle)	Halts are enabled. On power-up or restart, the system will enter console I/O mode at the completion of start-up diagnostics.
Down (dot outside circle)	Halts are disabled. On power-up or restart, the system will attempt to load software from one of the boot devices at the completion of start-up diagnostics.

Power-Up Mode Selection (3-position rotary switch)

Switch Position	Mode
Arrow	Run. If the system supports the Multinational Character Set (MCS), the user will be prompted for language only if the battery backup has failed. Full start-up diagnostics are run.
Face	Language inquiry (factory setting). If the system supports MCS, the user will be prompted for language on every power-up and restart. Full start-up diagnostics are run.
T in a Circle	Test. ROM programs run wraparound serial-line unit (SLU) tests.

Baud Rate Selection Switch (8-position rotary switch)

This switch sets the baud rate of the console terminal serial-line. The factory setting is 4800 baud. The baud rate of this switch must match that of the printer, if present.

Light-Emitting Diode (LED) Display

This indicator displays numbers of on-going steps of power-up tests and booting procedures. If a failure occurs, the display indicates the field replaceable unit (FRU) that is the most probable cause of the failure. Refer to Chapter 5, under the section titled Power-Up Messages, for a brief description of the hexadecimal numbers.

Printer Port

This is a 9-pin connector for a cable to a printer.

The System Power Switch



11-1-102-00

The system **power switch** controls the ac power. Setting the switch to 1 turns on the power. Setting the **power switch** to 0 turns off the power.

The Restart/Run Pushbutton

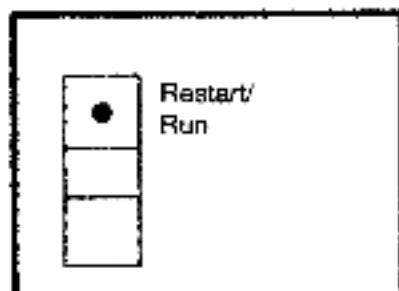

MLC-544-05

The **Restart/Run** momentary-contact pushbutton reboots the operating system software when pushed. Work in progress is lost.

When the system is on, the **Restart/Run** pushbutton glows green to indicate normal software operation. If the pushbutton does not glow, refer to Chapter 5 for troubleshooting information.

The DC OK Indicator

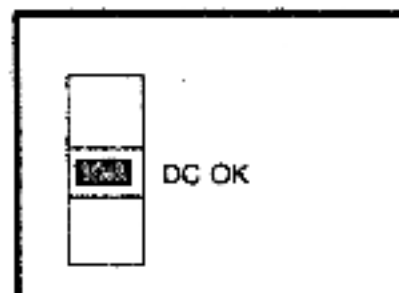

MLC-545-05

The **DC OK** indicator glows green when the system is generating power. If the indicator does not glow, the system is not generating power. Refer to Chapter 5 for troubleshooting suggestions.

The Halt Pushbutton

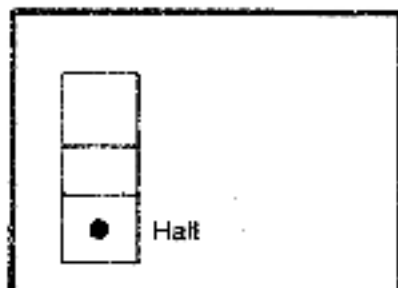

WLO-546-85

The **Halt** pushbutton stops the *program* currently running without shutting down the VAXstation II/GPX.

When the **Halt** pushbutton is pressed, it latches in and glows orange. The **Halt** pushbutton should be set in the out position and not glowing to allow for software operation.

The **Halt Enable/Disable** switch (on the back of the VAXstation II/GPX cabinet) is normally set to the disable position (up) to prevent the system from going into *console mode* when you execute a halt in a program. The disable position also stops devices (such as a printer) connected to the auxiliary port from halting the processor.

To get into console mode, shut down any software that may be executing and put the **Halt Enable/Disable** switch (located on the back of the system unit) in the enable position (down). Then, press the **Halt** pushbutton twice. Any data not saved before pressing the pushbutton will be lost. The *MicroVAX II Maintenance Manual* describes the console commands. You can also enter console mode from the workstation software. Consult your system software documentation.

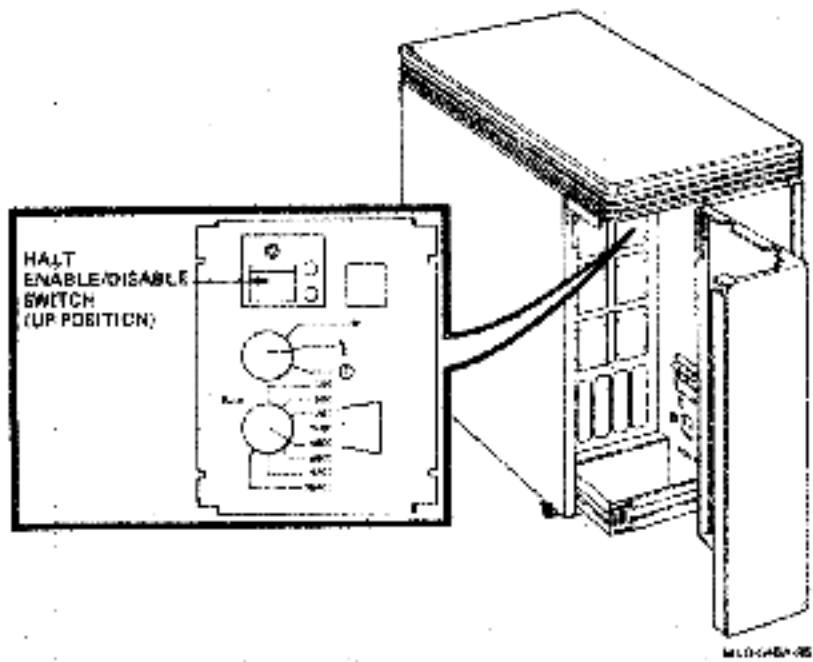

The Fixed Disk Pushbuttons

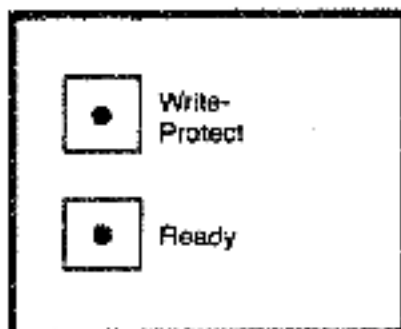

MLO-547-B5

Your system may contain one or more fixed disks with external pushbuttons. If your system does not have a fixed disk, these pushbuttons are inoperable.

The **Fixed Disk Write-Protect** pushbutton is set in the out position and not glowing for normal software operation. System software can read or write information on the disk. To write protect the disk, preventing system software from erasing or writing on the disk, push in the **Write-Protect** pushbutton. The pushbutton glows orange.

The **Fixed Disk Ready** pushbutton glows green when it is set to the out position and indicates that the fixed disk is ready to store information. When pushed in, the pushbutton stops glowing, and the fixed disk is disabled. In effect, the fixed disk is turned off.

Turning On the System

This procedure assumes that the system has been installed according to the installation instructions in this manual and that the system software has been installed. If the system software has not been installed, consult the software documentation and install the software.

Initial Control Panel Switch Settings

1. If you have a fixed disk, set the **Fixed Disk Ready** pushbutton to the out (ready) position.
2. Set the monitor **power switch** to 1 (on).
3. Set the system **power switch** to 1 (on).

When you turn on the power, the VAXstation II/GPX control panel indicators appear as described in Table 3-1.

Table 3-1: Normal Power-On Indications

Control/Indicator	Normal Indication
Restart/Run	Glow green
DC OK	Glow green
Halt	Not glowing
Fixed Disk Write Protect	Not glowing
Fixed Disk Ready	Glow green within 30 seconds
Tape Drive Load/Unload	Glow red for 4 seconds and then stops glowing
Monitor Power Indicator	Glow green

If you do not observe the indications listed in Table 3-1, refer to Chapter 5 for troubleshooting information.

The monitor displays the power-up screen.

Performing normal system tests.

7..6. 5..4. 3..

Tests completed.

Loading system software.

2..1..0

The monitor slowly displays the numbers 7 through 3, indicating completion of steps in the power-up system test. The VAXstation II/GPX performs power-on system tests each time you turn on the system.

Then, the monitor displays the numbers 2 through 0 to indicate that the VAXstation II/GPX system is loading the system software. The first screen for the system software appears on the monitor after a few seconds.

The VAXstation II/GPX system is now ready for use. Refer to the system software documentation for instructions on using the VAXstation II/GPX system.

Turning Off the System

To prevent loss of data and to ensure an orderly system shutdown, follow the system shut-down procedure described in your system software documentation.

Turn off the VAXstation II/GPX system by setting the **power switch** to 0 (off).

CAUTION: Before moving the monitor, turn it off and wait 30 seconds to allow static electricity on the CRT to discharge.

Color Monitor Controls and Indicators

The front and side of the monitor have the following six controls and indicators:

The **contrast control** lets you adjust the video display.

The **brightness control** allows you to adjust the video raster (background intensity) to compensate for ambient light in the room. To adjust the raster, set the **brightness control** to minimum. Slowly turn up the control until horizontal lines appear on the screen, then reduce the brightness until the lines disappear.

The **degauss switch** lets you clear picture distortion caused by external interference. Press the **degauss switch** after any movement of the monitor to correct color distortions. If you need to press the **degauss switch** a second time, first wait 10 minutes to allow the circuit to reactivate.

The **power switch** enables you to turn on or off the monitor. Press 1 to turn on the power. Press 0 to turn off the power.

The **tilt-lock lever** enables you to adjust the angle of the monitor. Set the **tilt-lock lever** back to adjust the tilt. Pull the lever forward to the original position to lock the monitor at the desired angle. The lock prevents the tilting mechanism from moving the monitor. You can swivel the monitor on the base, and the angle will be maintained.

The power indicator glows to indicate that power is applied to the monitor.

Figure 3-3: Front and Side Controls, Color Monitor

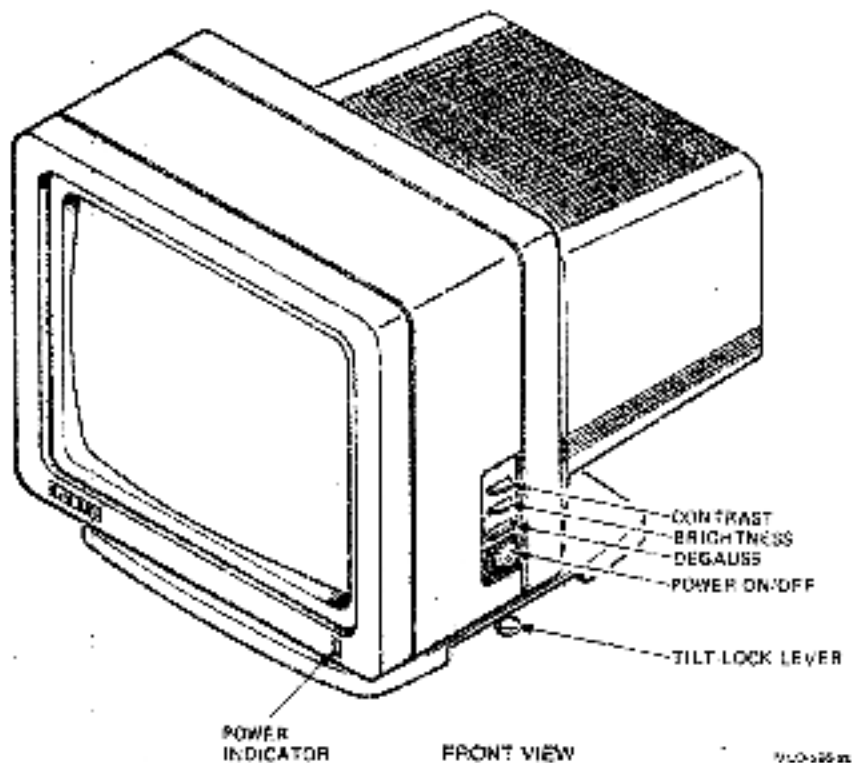

The back of the monitor has the following six connectors and controls:

The end of the R, G, and B video cables plug into the R, G, and B sockets. The monitor, keyboard, and pointing device are joined to the system unit through the video cable assembly, which screws into the cable assembly mounting hole.

The fuse protects the monitor from electrical damage.

The monitor power cord plugs into the power cord connector.

Figure 3-4: Rear Controls and Connectors, Color Monitor

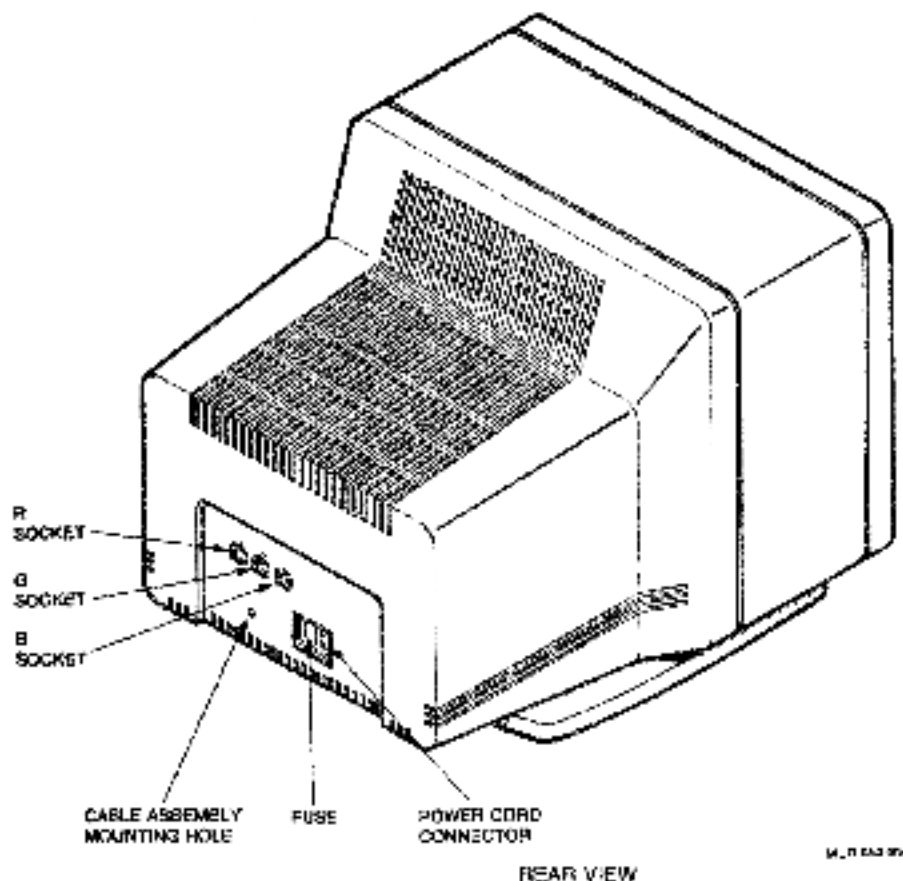

Fixed Disk Drive

The fixed disk drive, located inside the cabinet, stores information on a nonremovable disk.

The RD53 fixed disk stores up to 71 megabytes of data. The RD54 fixed disk stores up to 159 megabytes of data. Fixed disk systems are usually configured to include the TK50 tape drive for removable storage of data.

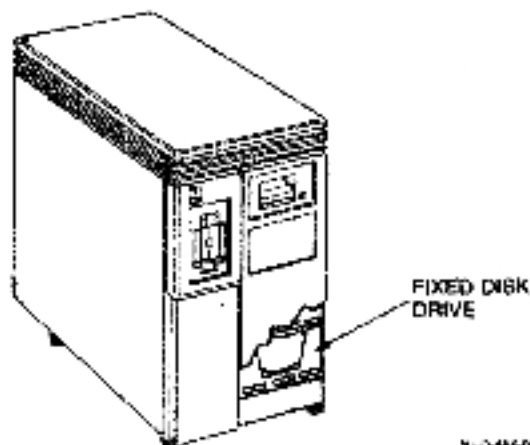

Tape Drive

The TK50 tape drive holds one removable TK50 magnetic tape cartridge. The information is magnetically stored on one side of a TK50 tape. Information can be erased, and new information stored in its place. Each tape cartridge holds 94.5 megabytes of information.

The tape cartridge can be used as both an input and output device. As an input device, it can be used to load software or data into the system. As an output device, the cartridge can be used to make copies (backups) of software or data on the tape cartridge media.

The tape drive has two primary controls: the cartridge release handle and the Load/Unload pushbutton. The cartridge release handle is used to insert or remove cartridges and lock them into position. The Load/Unload pushbutton controls winding and rewinding of the tape. The pushbutton is a 2-position control; when the pushbutton is first pressed in, the tape winds

onto the take-up reel inside the drive. When pressed again, the pushbutton pops out and winds the tape back into the tape cartridge.

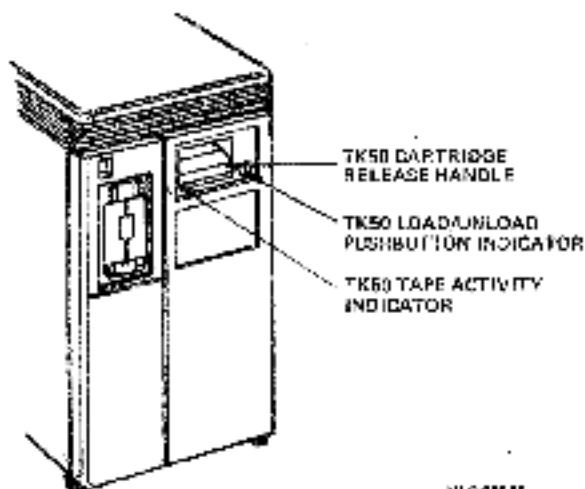

Inserting a Tape Cartridge

Make sure the system **power switch** is set to 1 (on) and the **Load/Unload** pushbutton is not glowing. The **Load/Unload** pushbutton glows red for approximately 4 seconds during the tape drive power-on self test. The pushbutton stops glowing, and the **Tape Activity** indicator glows green to show that you can begin the following procedure.

1. Pull out the **cartridge release handle**.
2. With the arrow on the tape cartridge pointing toward the **cartridge release handle**, insert the cartridge into the drive.
 - The **Load/Unload** pushbutton glows red.
 - The **Tape Activity** indicator stops glowing.
3. Push in the **cartridge release handle** to lock the tape in the operating position.
 - The **Load/Unload** pushbutton stops glowing.
 - The **Tape Activity** indicator glows green.

4. Press in the **Load/Unload** pushbutton.

- The **Load/Unload** pushbutton glows red.
- The **Tape Activity** indicator stops glowing.

The tape is loaded in 10-15 seconds. If a tape is new, the system performs a calibration sequence that takes approximately 40 seconds. The **Tape Activity** indicator flashes green rapidly and irregularly during calibration.

During loading, the **Load/Unload** pushbutton glows red. When the **Tape Activity** indicator glows green, the tape is ready to use.

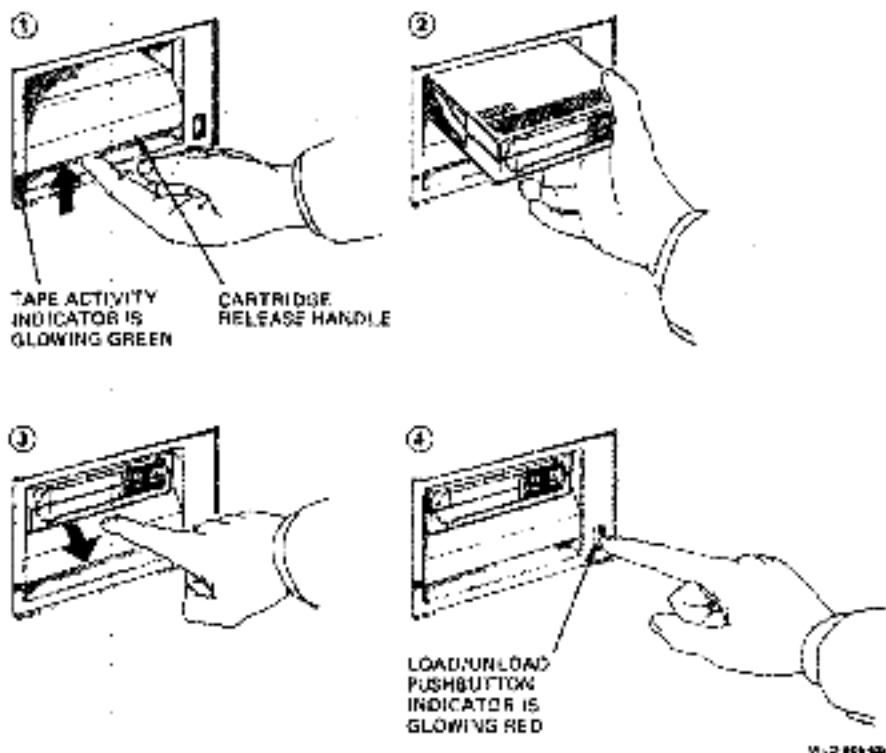

CAUTION: *Keep the cartridge release handle down when the Load/Unload pushbutton glows red. Make sure the Tape Activity indicator glows green before lifting the cartridge release handle.*

CAUTION: *If the Load/Unload pushbutton flashes red rapidly at any time, press it four times. If the problem persists, do not attempt to use the tape drive or to remove the tape cartridge. Call your service representative.*

Rewinding and Unloading a Tape Cartridge

Rewind and unload a tape before removing it from the tape drive.

1. Press the **Load/Unload** pushbutton to the out position.
 - The **Load/Unload** pushbutton and **Tape Activity** indicators flash slowly, but not in unison, as the tape rewinds to the beginning (unless the tape was already at the beginning).
 - The **Load/Unload** pushbutton glows red, and the **Tape Activity** indicator stops glowing as the tape unloads into the cartridge.
 - When the procedure completes, the **Load/Unload** pushbutton stops glowing and the **Tape Activity** indicator glows green.
2. Pull out the **cartridge release handle**.
3. Remove the tape cartridge and store it in a safe place.
4. Push in the **cartridge release handle**. The **Tape Activity** indicator glows green, showing that power is supplied to the drive.

NOTE: *Rewinding a tape can also be done under software control. Refer to your software documentation for information.*

Table 3-2: Tape Drive Controls and Indicators

Control	Position	Condition
Load/Unload Pushbutton	In	Slowly flashing. Tape is loading (10-15 seconds). Rewinding and loading can take up to 2 minutes.
	Out	Tape is rewinding and unloading.
Tape Activity Indicator	Load/Unload Pushbutton Indicator	Condition
Off	Off	No power to the tape drive.
On	Off	Safe to lift cartridge release handle to insert or remove a tape. Power is present.
Off	On	Unsafe to lift the cartridge release handle. <ul style="list-style-type: none"> • Power-on self test is occurring--glows for only 4 seconds. • Cartridge is inserted but handle is still up. • Tape is loading or unloading. • Tape is stopped.
On	On	Tape loaded successfully.
Flashing	On	Tape is in motion (except rewind). Read/write commands are being processed. Irregular fast flashing means tape calibration is occurring. ¹
Flashing	Flashing	Tape is rewinding.
Flashing	Flashing rapidly	A fault is occurring. Press and release the Load/Unload pushbutton four times. If the problem persists, do not attempt to use the tape drive or to remove the tape cartridge. Call your service representative.

¹If a tape is new, the system performs a calibration sequence that takes approximately 40 seconds.

Table 3-2 (Cont.): Tape Drive Controls and Indicators

Handle	Position	Function
Cartridge Release Handle	Out	Allows a tape to be inserted or removed after rewind and unload operations are completed.
	In	Locks tape in operating position.

Protecting Tape Cartridges from Accidental Overwriting

The TK50 tape cartridge has a write-protect feature to prevent loss of data by accidental overwriting. To write-protect the tape, slide the *write-protect switch* toward the tape label slot.

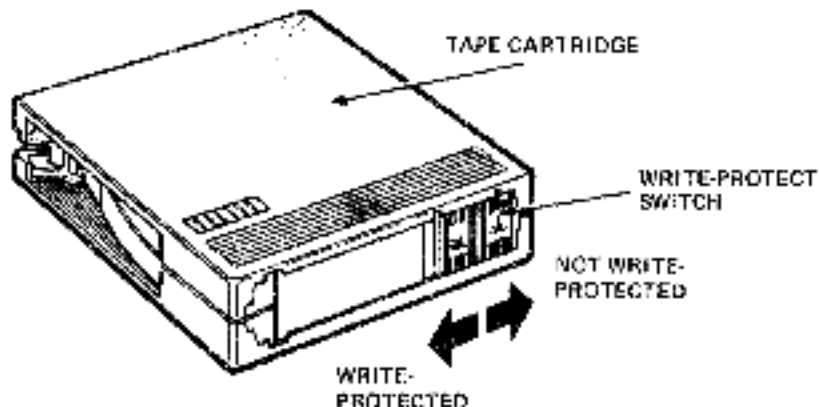

MLC 888 86

NOTE: *The system can read information on the tape, regardless of the position of the write-protect switch. However, the system cannot write data to the tape when the switch is set to the write-protect position.*

Handling and Storing Tape Cartridges

Follow these guidelines when handling and storing TK50 tape cartridges:

- Do not touch the exposed surface of the tape.
- Do not throw or drop the tape cartridge.
- Store tape cartridges in a dust-free environment.
- Do not apply adhesive labels to the top, bottom, or sides of a cartridge. Place labels **only** in the label slot on the front of the tape cartridge.
- Write on the identification label before inserting it in the label slot on the front of the cartridge.
- Allow new blank and prerecorded tapes to stabilize at room temperature for 24 hours before using them.
- Keep tape cartridges away from direct sunlight, heaters, and other sources of heat. Store tape cartridges in a stable temperature between 10 and 40 degrees Celsius (50 and 104 degrees Fahrenheit).
- Keep tape cartridges away from magnets and equipment such as motors, transformers, terminals, monitors, and audio equipment, that generate magnetic fields.
- Keep tapes away from x-ray equipment.

Dual Diskette Drive

The RX50 dual diskette drive holds up to two 13.13-centimeter (5.25-inch) diskettes. Each diskette stores 400 kilobytes of information, which is roughly 150 typewritten pages.

Close the drive door when using a diskette. The drive does not work with the door open.

A **Diskette Activity** indicator on each drive glows red when a drive is in use. Keep the drive doors closed when the **Diskette Activity** indicators are glowing red. Opening the doors could erase data or delete information.

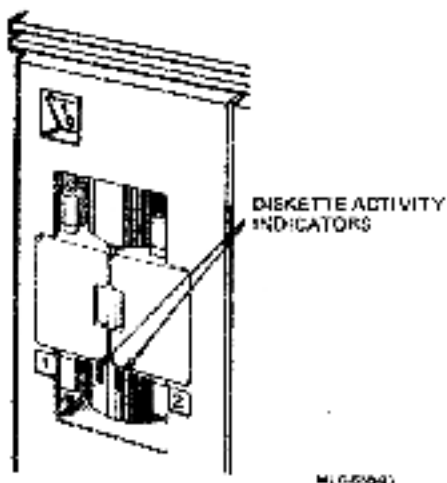

The information on RX50 diskettes is magnetically stored on one side of the diskette. Stored information can be erased, and new information stored in its place.

The diskette, permanently enclosed in a cover, rotates inside the cover. The soft fabric lining of the cover continuously cleans the diskette.

NOTE: Use only formatted RX50 diskettes, available from DIGITAL or DIGITAL's licensed distributors.

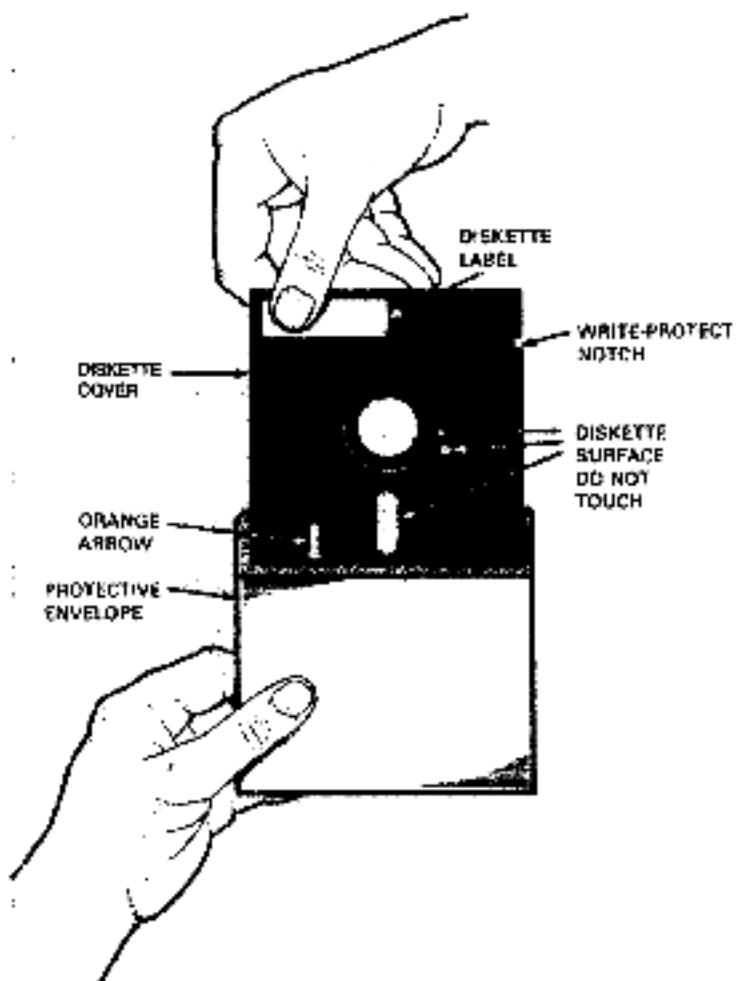

910-000000

Inserting a Diskette

Keep the diskette drive door closed while a **Diskette Activity** indicator is glowing red. Opening the door might damage the drive *heads*. Wait for the indicator to stop glowing, which indicates that diskette drive activity has finished.

- Open the drive door by pressing on the door's outer edge.
- Align the orange arrow on the diskette cover with the orange stripe on the drive and insert the diskette. The *write-protect notch* is down for drive 1 and up for drive 2.
- After inserting the diskette, press the drive door closed. Do not use excessive force; the door should close easily.

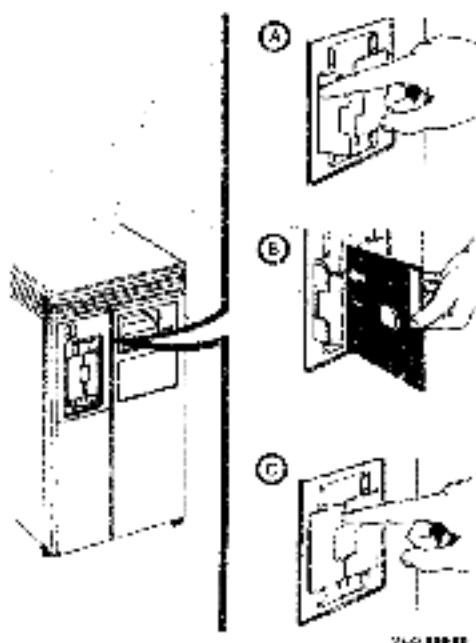

Protecting Diskettes from Accidental Overwriting

The RX50 diskette has a write-protect feature to prevent loss of data from accidental overwriting. To protect the data, cover the write-protect notch on the side of the cover with a self-adhesive foil tab supplied with your diskettes. Remove the tab when you want to add, change, or delete information.

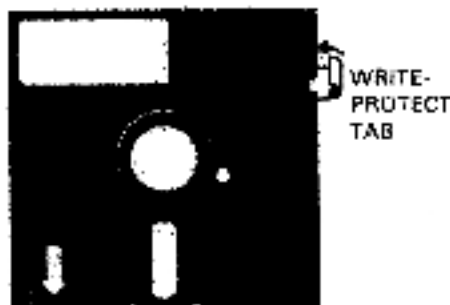

4110-588-01

Handling and Storing Diskettes

Incorrect handling and storing of diskettes can damage them (and the RX50 recording head) and cause loss of data. The following precautions should be taken:

- To keep out dust and dirt, put the diskette in its envelope when the diskette is not in use.
- Do not fold or bend the diskette cover.
- Do not touch the recording surface of the diskette. When out of its envelope, handle only the top (label area) of the diskette.
- Store the diskette vertically (with the label at the top) and loosely to prevent the cover from becoming warped.
- Write on the label before applying it to the diskette cover to avoid creasing the cover. If you need to change the label, use a felt-tipped pen.
- Store the diskette away from direct sunlight and heaters.
- Store the diskette away from strong magnetic fields and steel objects. Magnetic fields (produced by motors, transformers, and terminals) can erase data.

Back-up Copies

A back-up copy is a copy of files stored on the VAXstation II/GPX fixed disk, diskette, or tape. Making back-up copies of files ensures a copy for you in case information is accidentally lost. As a general rule:

- Make back-up copies on diskettes or magnetic tape.
- Make a daily back-up copy of information you create or change that day.
- Make a weekly back-up copy of information stored on your fixed disk drive.
- Store back-up copies in a safe place.

Make back-up copies of system software files as described in the system software documentation.

Chapter 4

Options

The options currently supported by the VAXstation II/GPX are divided into six categories and consist of the following:

- *Hard-copy Output Devices*—Printers and Plotter (LN03, LN03 PLUS, LA50, LA75, LA210, LPS40, LCG01, and LVP16)
- *Input Devices*—Tablet (VSXXB-AB), Mouse (VSXXA-AA)
- *Memory*—Memory Modules (MS630-BA, MS630-BB, MS630-CA)
- *Video*—4-Plane (M7168) Module
- *Storage Devices*—Fixed Disk Drives (RD53 and RD54), Tape Drive (TK50), and Dual Diskette Drives (RX50)
- *Communications*—Ethernet communication module (DEQNA), ThinWire Ethernet connectors and terminators, the DIGITAL ThinWire Ethernet Station Adapter (DESTA), *Asynchronous Multiplexers* (DZQ11 and DHV11), *Synchronous Line Controllers* (DMV11 and DFPV11), Programmable Controller (KMV11), and *Modems* (DF03, DF112, DF124, and DF224).

This chapter describes each option and directs you to the appropriate installation instructions. You may install a printer, the tablet, and the color monitor yourself. However, contact your service representative to install all the other options.

The VAXstation II/GPX is also upgradeable to a 2-user ULTRIX system having two monitors, two keyboards, two input devices, and two VCB02 graphics modules. Contact your sales representative for information on this upgrade.

CAUTION: *If you attempt to install the memory modules, video module, disk drive subsystems, tape drive, dual diskette drive, communications module, asynchronous multiplexers, synchronous line controllers, or programmable controller, you might damage the system.*

To order an option after initial system installation, contact your sales representative. For more information on those options, refer to the documents listed at the end of each section² and the *VAXstation II/GPX Maintenance Manual*.

Hard-Copy Output Devices

The VAXstation II/GPX can be used with seven printers: the LN03, the LN03 PLUS, the LPS40, the LA210, the LA75, the LA50, and the LCG01. The VAXstation II/GPX can also be used with the LVP16 plotter. Each of the following sections describes one of these options. The final section explains how to connect a printer or plotter to a VAXstation II/GPX.

Printers

The LN03

The LN03 laser printer is a desk-top, nonimpact printer that produces letter-quality text at 8 pages/minute. For systems running MicroVMS, the printer can also display graphics.

The LN03 offers 16 fonts, including Courier, Elite, and the VT100Line-Drawing Set (the DIGITAL standard set), ASCII multinational technical character sets and 12 national language character sets can also be used.

The printer comes with three character sets. If you want to mix type styles and point sizes, the LN03 can print up to 24 fonts/page. To expand memory or add additional fonts, you can purchase more programmable RAM or precoded ROM cartridges from DIGITAL.

The LN03 uses only cut sheet paper. A paper cassette holds 250 sheets of paper. The printer automatically collates output for you in its face-down output tray. The LN03 can also handle preprinted single-part forms, transparencies, and labels. The LN03 can print in either landscape (horizontal) or portrait (vertical) mode.

CAUTION: When the LN03 or LN03 PLUS is connected to an operating VAXstation II/GPX, make sure the *Half Enable/Disable* switch is disabled before powering on and off the system. Otherwise, you cause the irretrievable loss of data.

² These documents pertain only to customers in the United States. If you are not a U.S. customer or if you require translated documents, check the appropriate country's product listing.

The LN03 weighs 28 kilograms (66 pounds).

Figure 4-1: The LN03

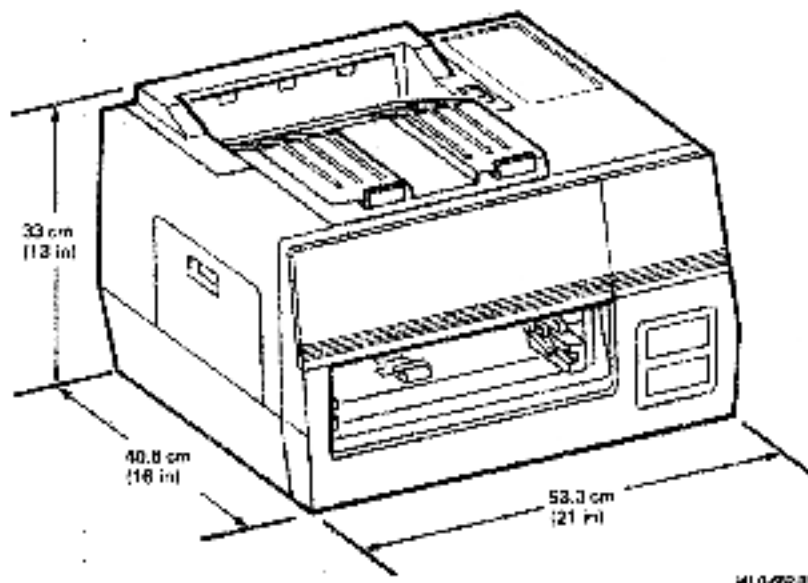

To order an LN03 printer after the initial system installation, contact your sales representative. You can install the LN03 printer yourself. After assembling the printer, see the section *Printer and Plotter Connection to the System*.

For more information about the LN03 printer, see the following documents:

- *Installing and Using the LN03* (Order No. EK-0LN03-UG-001)
- *LN03 Programmer Reference Manual* (Order No. EK-0LN03-RM-001)
- *LN03 Maintenance Kit Guide* (Order No. EK-LN03U-MG-001)
- *LN03 Toner Kit Guide* (Order No. EK-0LN03-MG-001)

The LN03 PLUS

The LN03 PLUS is the upgrade configuration of the LN03 laser printer. The LN03 PLUS system consists of a base LN03 laser printer and an LN03S bitmap option module. The LN03 PLUS requires the firmware microcode V4.4 to be installed in the base LN03 printer.

The LN03 PLUS enhances the ability of the LN03 printer to print documents composed of text and graphics. The LN03 PLUS enables you to process ANSI and Tektronix data files with any ratio of text to graphics and with no limits on image complexity.

The LN035 bitmap option module consists of a *printed circuit board* that is inserted into the available option slot of the LN03 printer. This option module's key feature is an on-board memory capacity of one Mbyte of dynamic RAM used for bitmap storage. The LN035 option module also contains up to 128 Kbytes of ROM for program and font storage.

The printer and *host system* communicate through the standard RS232-C serial interface.

All setup features in the LN03 PLUS are the same as in the base LN03 and are controlled through the default setting of configuration switches or under program control.

CAUTION: *When the LN03 or LN03 PLUS is connected to an operating VAXstation II/GPX, make sure the Halt Enable/Disable switch is disabled before powering on and off the system. Otherwise, you cause the irretrievable loss of data.*

To order an LN03 PLUS printer or an LN035 option module for installation into an existing LN03 printer, contact your sales representative.

The PrintServer 40 (LPS40)

The PrintServer 40 is a MicroVAX II-based laser printer containing POSTSCRIPT[®] software. The PrintServer 40 is designed as an Ethernet node in order to serve many users.

A dedicated MicroVAX II-based data controller interprets *applications programs* that output in POSTSCRIPT, a powerful industry-standard page description language. The PrintServer 40 supports existing software, using ANSI text/sixels, ReGIS, or Tektronix[®] 4010/4014 format through the use of host-based translators.

The PrintServer 40 prints monochromatically at a rate of 40 pages per minute at a resolution of 750 x 750 dots per centimeter (300 x 300 dots per inch). Paper sizes include letter, legal, and ledger, and A4, A5, B4, and B5 metric sizes. A large capacity input tray holds 2000 sheets of cut sheet paper and two auxiliary trays hold 250 sheets each.

The PrintServer 40 contains a library of 29 typefaces that may be scaled to any point size, rotated to any degree, and positioned anywhere on a page, through the use of POSTSCRIPT commands.

Specifications for the PrintServer 40:

- Size: 102.62 cm (40.4 in) high x 72.14 cm (28.4 in) deep x 152.4 cm (60 in) wide
- Weight: 219.99 kilograms (484 lb)
- Voltage:
 - 200/208/240 V, 60 Hz
 - 200/220/230/240 V, 50 Hz

Figure 4-2: The PrintServer 40 (LPS40)

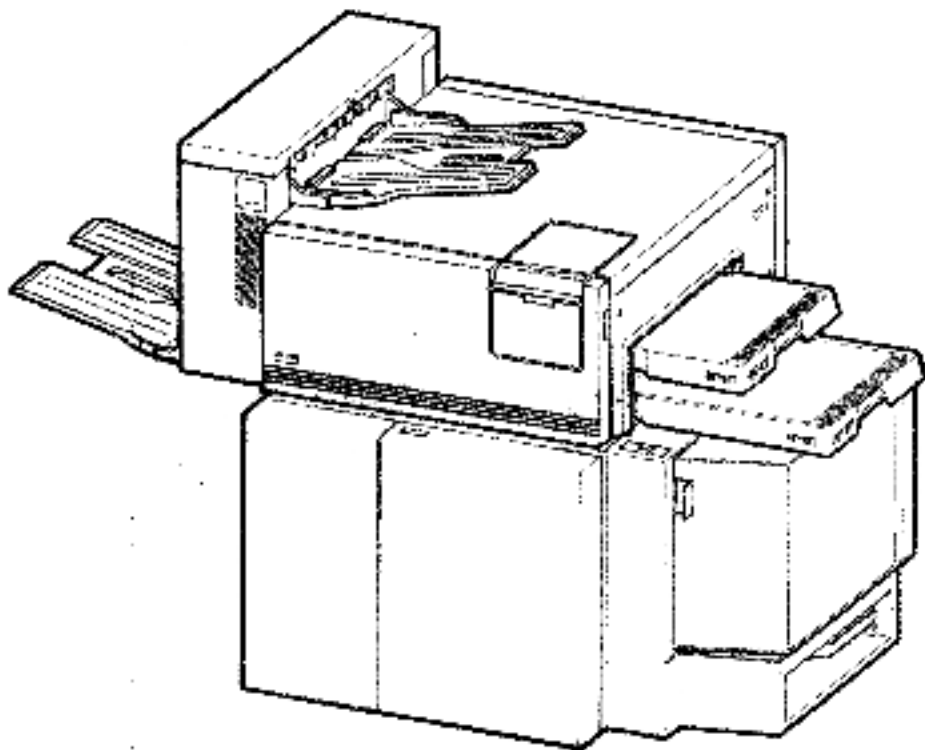

402-100-00

The LA210

The LA210 is a *dot-matrix* desk-top printer that can produce high-speed drafts (240 characters/second) or near letter-quality correspondence (40 characters/second). With the addition of an optional font cartridge, the LA210 can print memo-quality correspondence (80 characters/second). The LA210 also prints bitmap graphics.

The printer can print in USASCII, 10 national languages in Courier 10, and the VT100 line-drawing set (the DIGITAL standard set). Other features include three optional typefaces: Gothic, Orator, and Italic. Over 30 optional character sets, including symbols and technical characters, can be added by plug-in font cartridges. You can select up to eight character widths.

The LA210 prints on single-sheet and fanfold paper and handles forms with up to four parts. The printer's carriage accommodates paper ranging in width from 8.9 centimeters (3.5 inches) to 37.8 centimeters (14.9 inches).

The printer weighs 11.3 kilograms (25 pounds).

Figure 4-3: The LA210

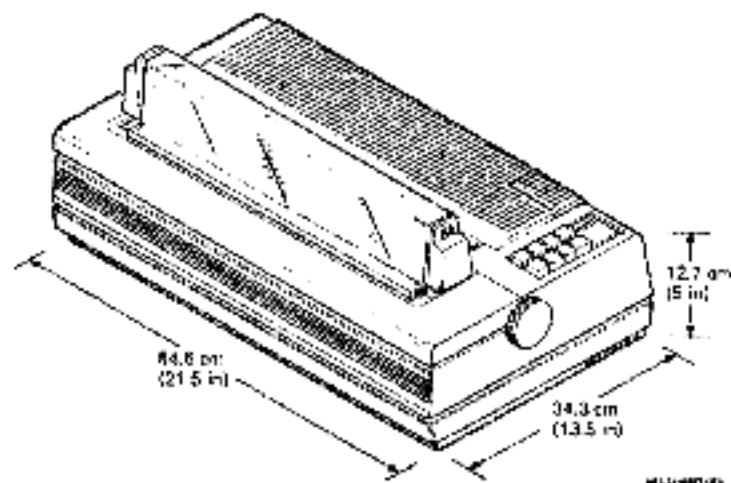

To order an LA210 printer after the initial system installation, contact your sales representative. You can install the LA210 printer yourself. After assembling the printer, see the section Printer and Plotter Connection to the System.

For more information about the LA210 printer, see the following documents:

- *Installing the LA210 Letterprinter* (Order No. EK-LA210-IN-001)
- *LA210 Letterprinter User Guide* (Order No. EK-LA210-UG-001)
- *LA210 Letterprinter Programmer Reference Manual* (Order No. EK-LA210-RM-001)
- *LA210 Letterprinter Operator and Programmer Reference Guide* (Order No. EK-LA210-RC-001)
- *LA210 Letterprinter Emulation Modes Reference Guide* (Order No. EK-LA210-RG-001)

The LA75

The LA75 is a desk-top dot-matrix printer that can produce sixel-protocol bitmap graphics. The LA75 prints in draft speed (250 characters/second), memo speed (125 characters/second), and letter-quality speed (32 characters/second). The printer offers optional font cartridges and international character sets. You can use office stationery or fanfold paper.

The LA75 is compatible with DIGITAL's LA50 and LA210 printers as well as IBM's PRO printer. The LA75 uses the DEC423 serial interface.

The LA75 weighs 10 kilograms (22 pounds).

Figure 4-4: The LA75

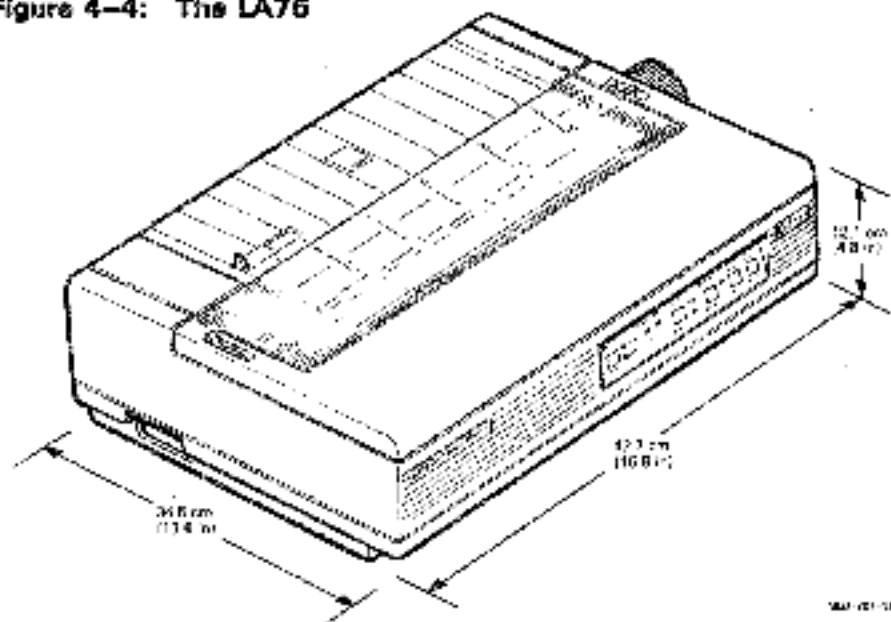

To connect the LA75 printer to your VAXstation II/GPX you need an adapter, the H8571-B and a cable, either the BC16E-10 (30.48 meters/10 feet), BC16E-25 (76.2 meters/25 feet), or the BC16E-50 (152.4 meters/50 feet).

To order an LA75 printer and the necessary cable and adapter after the initial system installation, contact your sales representative.

The LA50

The LA50 is a desk-top dot-matrix printer that can produce bit-map or character cell graphics.

The LA50 prints in draft speed (100 characters/second) and memo speed (50 characters/second). The printer offers one font and six character widths. Ten national character sets are available. You can use office stationery or fanfold paper.

The LA50 weighs 8.5 kilograms (18.7 pounds).

Figure 4-5: The LA50

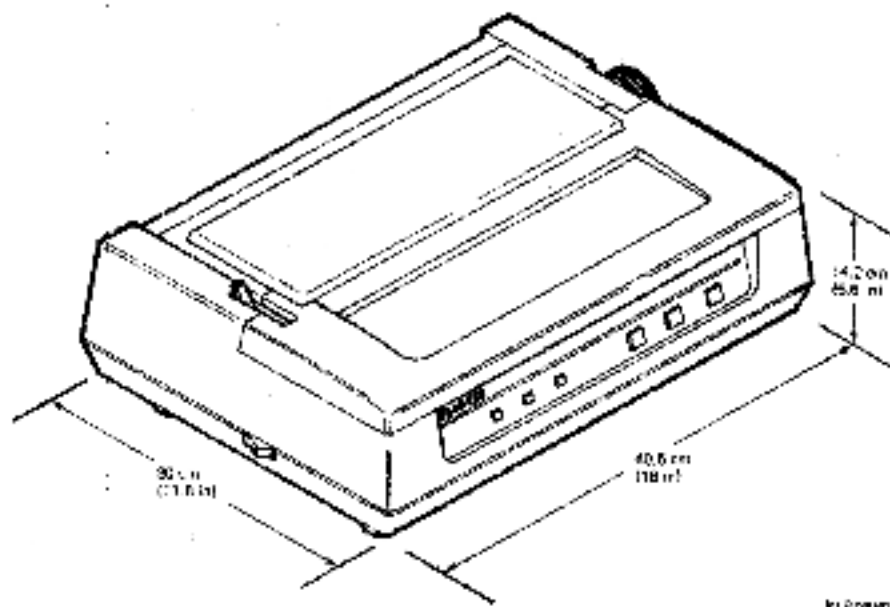

To order an LA50 printer after the initial system installation, contact your sales representative. You can install the LA50 printer yourself. After assembling the printer, see the section *Printer and Plotter Connection to the System*.

For more information about the LA50 printer, see the following documents:

- *Installing and Using the LA50 Printer* (Order No. EK-0LA50-UG)
- *LA50 Printer Programmer Reference Manual* (Order No. EK-0LA50-RM-001)

The LCG01

The LCG01 is a high-resolution serial ink-jet color printer. The LCG01 provides 385 dots/centimeter (154 dots/inch) resolution and it prints in 216 colors.

The printer offers five different fonts. One is ROM resident, and the others are *down-line loaded* at system startup. The LCG01's automatic sheet feeder holds paper and transparencies.

The LCG01 color printing system consists of the LCG01 color printer and an LCG01 graphics protocol processor. The LCG01 printer weighs 31.8 kilograms (70 pounds), and the controller weighs 11.7 kilograms (26 pounds). The printer measures 21.6 centimeters (8.5 inches) x 61 centimeters (24 inches) x 61.6 centimeters (24.25 inches).

To order an LCG01 color printing system after the initial system installation, contact your sales representative. You can install the LCG01 yourself. After assembling the printer, see the section *Printer and Plotter Connection to the System*.

For more information about the LCG01, see the following documents:

- *LCG01 Installation and Operator Manual* (Order No. EK-LCP01-IN)
- *LCG01 User's Guide* (Order No. EK-LCP01-UG)
- *LCG01 Pocket Service Guide* (Order No. EK-LCP01-PS)

Plotter

The LVP16

The LVP16 is a high-performance 6-pen color graphics plotter. The LVP16 prints graphics at 38 centimeters/second (15 inches/second). Using any of 19 character sets, the LVP16 can annotate graphs with text in any direction, with or without character slant, and in varying sizes. The LVP16 is accurate to 0.025 millimeter (0.001 inch).

Multicolor high-quality graphics are produced by programs, using the front-panel selection of six pens. For drawing with additional colors, the program can be stopped, and additional pens can be manually installed. The fiber-tip pens are available in two nib sizes along with a selection of ten vibrant colors for paper and seven for transparencies.

The LVP16 can be used with plain paper or transparencies. Each page is manually removed and inserted for every plotting.

The LVP16 weighs 7 kilograms (16 pounds) and measures 12.7 centimeters (5 inches) x 56.8 centimeters (22.4 inches) x 36.7 centimeters (14.5 inches).

To order an LVP16 plotter after initial system installation, contact your sales representative. You can install the LVP16 plotter yourself. After assembling the printer, see the section *Printer and Plotter Connection to the System*.

To properly operate the LVP16, set the rocker switches according to the following list. This information supplements the *LVP16 Graphics Plotter Owner's Manual*.

- B1 through B4 control baud rate. For example, set B1 and B4 to on for a 4800-baud rate.
- The next two switches control paper size. For example, set to US and A4 for United States letter size paper.
- The Y/D switch controls cabling. The D setting is for a direct connection, and the Y setting is for the eavesdrop connection.
- The S1 and S2 switches control byte size and parity. Set both to off for 8-bit bytes and no parity checking.

For more information about the LVP16, see the following documents:

- *LVP16 Graphics Plotter Owner's Manual* (Order No. EK-LVP16-OM)
- *LVP16 Graphics Plotter Programmer Reference Manual* (Order No. EK-LVP16-RM)
- *The LVP16 Reference Card*

Printer and Plotter Connection to the System

Cables are required to connect a printer or plotter to the VAXstation II/GPX. The LN03, LA210, LA50, and LCP01 printers require the BCC08 cable, and the LVP16 plotter requires the BCC19 cable. You must order a cable in addition to the printer or plotter.

For systems running ULTRIX, you must also add print commands to the system (see the *ULTRIX Workstation Software and Management Guide*) and set the printer for 7-bit ASCII (refer to the appropriate printer manual). To connect a printer or plotter to a VAXstation II/GPX, follow the instructions below.

1. Make sure that the **power switches** for the printer or plotter and the VAXstation II/GPX are off.
2. Open the back door of the system unit.
3. Check that the printer or plotter and the system unit are set to the same baud rate (4800).
4. Attach the larger end of the printer or plotter cable to the back of the printer or plotter.

5. Attach the free end of the printer or plotter cable to the printer port on the I/O distribution panel, which is located on the rear of your VAXstation II/GPX (see Figure 4-6).

Figure 4-6: Printer and Plotter Connection to the System

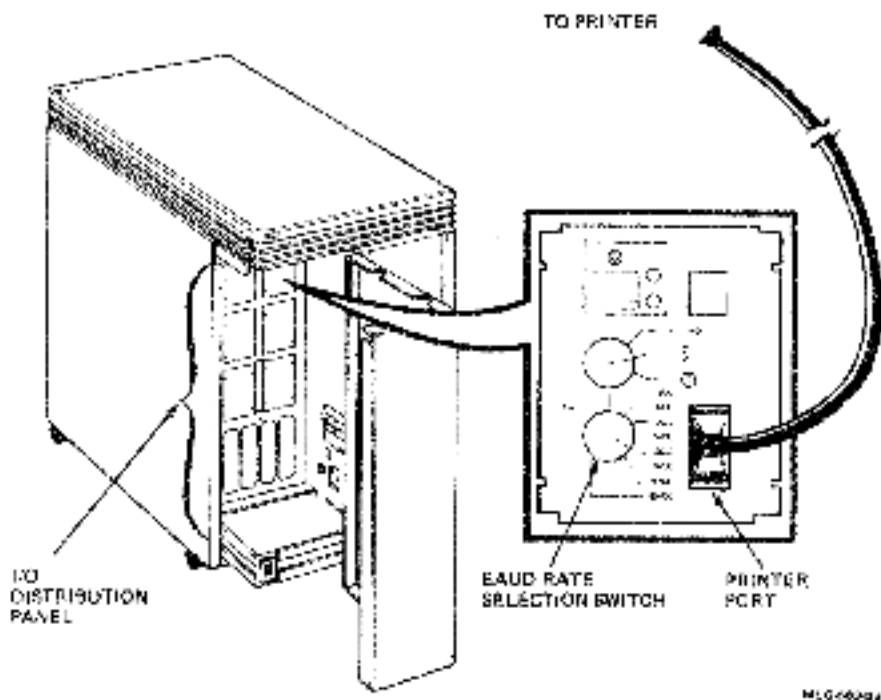

6. Close the back door of the system unit.

NOTE: If you are connecting the LA210 printer to the VAXstation II/GPX, make sure that XOFF and wrap are enabled. This may require toggling switches on the printer as explained in the LA210 documentation.

Input Devices

The Tablet

The tablet system consists of a digitizing tablet, a puck, a 2-button stylus, and a 1.5-meter (5-foot) power/signal cable. The tablet with the puck or stylus may be used as a pointing device instead of the mouse for menu selection, graphics entry, and cursor control.

The tablet is an *input device* that sends X-Y coordinates to the VAXstation II/GPX puck on the tablet's surface. The tablet has a resolution of 79 counts/millimeter (200 counts/inch). The stylus is used like a pen, while the puck is similar to a mouse, but instead glides on a felt bottom.

The tablet communicates with the VAXstation II/GPX through an asynchronous, full-duplex serial *interface* at 4800 baud (+/-2%).

The active area of the tablet is 279 millimeters x 279 millimeters (11 inches x 11 inches). The tablet weighs 3.2 kilograms (7 pounds).

Figure 4-7: The Tablet

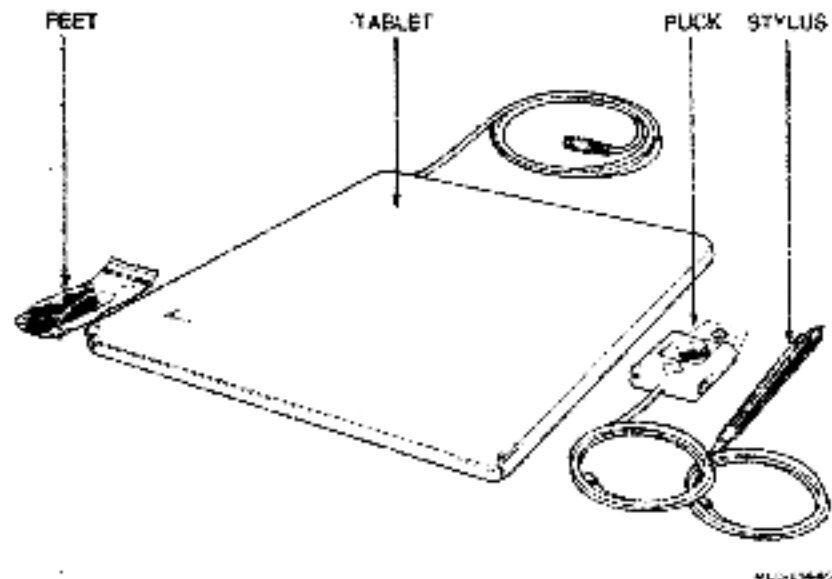

To order a tablet after the initial system installation, contact your sales representative. To install the tablet yourself, see Chapter 2.

For more information about the tablet, see:

- *Tablet Information Sheet* (Order No. EK-VSXXB-IN)

The Mouse

The mouse is a small, circular, plastic-bodied input device with three buttons. You use the mouse and buttons to position the cursor, enter graphics, and select on-screen items. Signals from the mouse are transferred to the monitor through a 1.5-meter (5-foot) cable.

Memory

The Memory Modules

The VAXstation II/GPX comes with a minimum of 5 megabytes of memory. Optional memory expansion modules allow you to expand to a total of 16 megabytes of memory. The following describes the additional memory expansion modules:

Part Number	Description
MS630-BA	2M Memory Expansion Module, quad-height module with 256K RAM (half populated MS630-BB).
MS630-BB	4M Memory Expansion Module, quad-height module with 256K RAM.
MS630-CA	8M Memory Expansion Module, quad-height module with 256K RAM.

To order a memory module after the initial system installation, contact your sales representative. Contact your service representative to install a memory module.

For more information about the memory modules, see:

- *KA630-A CPU Module User's Guide* (Order No. EJ-KA630-UC)

Video

The Video Subsystem

One VCB02 Video Subsystem consists of:

- The M7169 base module
- One or, optionally, two M7168 4-plane modules

The VAXstation II/GPX is also available as a 2-user system with two VCB02 video subsystems, two color monitors, two input devices, and two keyboards.

The 4-plane module provides high-performance, high-resolution, full-page direct memory access (DMA) color video subsystems based on the Q22-bus. The module, based on a VLSI graphics coprocessor, off loads the MicroVAX II/GPX main processor from computation-intensive graphics tasks.

The VAXstation II/GPX's existing 4-plane video subsystem can display 16 colors simultaneously. If a second 4-plane module is added, the video subsystem is upgraded to an 8-plane video subsystem, which can display 256 colors simultaneously. The modules allow parallel processing in multiple planes so that no degradation in performance occurs as planes are added.

The 4-plane module provides variable character size or positioning and inherent graphics capability. The module's major hardware components are: four video processor (DC322) chips, four planes of video memory with two pages/plane, subsystem support logic, video shifters, and cable connectors for the base module interface.

To order an additional 4-plane (M7168) module after initial system installation, contact your sales representative. Contact your service representative to install this option.

For more information on the 4-plane module, see the following document:

- *VCB02 Video Subsystem Technical Manual* (Order No. AZ-GUGAB-MN), which is in this binder.

Storage Devices

The VAXstation II/GPX has four mass storage devices available as options. They are:

- The RD53 fixed disk drive
- The RD54 fixed disk drive
- The TK50 tape drive
- The RX50 dual diskette drive

Table 4-1 shows the optional storage devices, the option package number, and the controller that allows your system to access the storage device. You can add optional storage devices up to your system's limit. Contact your sales or service representative to determine your system's specific requirements.

Table 4-1: Optional Storage Devices

Storage Device	Option Package Order Number ¹	Required Controller
Fixed Disk Drives		
RD53	RD53A-BA	RQDX3-BA
RD54	RD54A-EA	RQDX3-BA
Tape Drive		
TK50	TK50-AA	TQK50-BA
Dual Diskette Drive		
RX50	RX50A-BA	RQDX3-BA

¹The option packages contain the storage device and necessary parts to completely connect it to your system.

The Fixed Disk Drives

The two fixed disk drives available for the VAXstation II/GPX are the RD54 and RD53. The RD54 has a formatted capacity of 159 megabytes. The RD53 has a formatted capacity of 71 megabytes.

A fixed disk drive provides additional data storage for the VAXstation II/GPX. The fixed disk drive is mounted inside the system enclosure.

The VAXstation II/GPX in a BA123 Enclosure supports a maximum of four fixed disk drives with either a 4- or 8-plane video subsystem. Contact your service representative for information about your specific system capacities.

To order a fixed disk drive after the initial system installation, contact your sales representative. Contact your service representative for installation.

For more information about the fixed disk drives, refer to the following documents:

- *RD53 Disk Drive Technical Description* (Order No. EK-RD53A-TD-001)
- *RD54 Disk Drive Technical Description* (Order No. EK-RD54A-TD-001)

The Tape Drive

The TK50 tape drive, with a TK50 tape cartridge, provides additional data storage for your system and can be used to load software, including system diagnostics.

For a more complete description of the TK50 tape drive, see Chapter 3. To order a TK50 tape drive after the initial system installation, contact your sales representative. You will need to order the tape drive, the TK50 tape cartridge, and the signal cable option package. Contact your service representative to install these options.

For more information about the TK50 tape drive, see the following documents:

- *TK50 Tape Drive Subsystem Owner's Manual* (Order No. EK-LEP05-OM)
- *TK50 User's Guide* (Order No. EK-OTK50-UG-001)
- *TK50 Technical Manual* (Order No. EK-OTK50-TM-001)

The Dual Diskette Drive

For a description of the RX50 dual diskette drive, see Chapter 3. To order an RX50 dual diskette drive after the initial system installation, contact your sales representative. You will need the dual diskette drive option package (RX30A-BA) and the signal cable option package (17-00867-01). Contact your service representative to install this option.

For more information about the dual diskette drive, see the following document:

- *The RX50 Diskette Drive Technical Description* (Order No. EK-RX30A-TD-001)

Communications

The Ethernet Communication Modules

The DEQNA is a Q22-bus-compatible communication module that interfaces between an Ethernet *Local Area Network (LAN)* and a VAXstation II/GPX.

With a DEQNA module interface and communications software, the VAXstation II/GPX system becomes a *node* on a *network* and can communicate with other computers that are also nodes on the network. The DEQNA also enables a VAXstation II/GPX to be *down-line loaded* with a *system image* from a *host* computer on the network.

If the DEQNA module board is ordered after initial system installation, you must contact your service representative to install it. Once the modules are installed, the VAXstation II/GPX may join an existing Ethernet network either through a DELNI or an H4000 transceiver.

The DELNI (Digital Equipment Local Area Network Interconnect) is a low-cost Ethernet device consisting of a short section of coaxial cable containing eight transceivers. Each transceiver supplies a port for one system on the network. The DELNI is limited to a range of 35–40 meters (112–128 feet), but can be expanded through a connection to a second DELNI or to a larger Ethernet network. The ninth port on the DELNI allows for such a connection. To order a DELNI, contact your sales representative.

The H4000 Ethernet Transceiver can accommodate a more extensive network. The H4000 can be configured with 100 nodes for each 500-meter (1600-foot) segment. The transceiver consists of a small printed circuit board and a cable-tapping assembly contained in a rugged plastic housing. This installation also requires a transceiver cable. To order an H4000 or transceiver cable, contact your sales representative.

You may connect the system to a DELNI yourself. However, you must contact your service representative to connect the VAXstation II/GPX to an H4000 transceiver.

You need a BNE3x cable in order to connect a DELNI or an H4000 transceiver to a VAXstation II/GPX. To order additional cable, contact your sales representative. The BNE3x transceiver cable comes in four types:

- BNE3A—PVC, straight connector
- BNE3B—PVC, right-angle connector
- BNE3C—Teflon, straight connector
- BNE3D—Teflon, right-angle connector

The BNE3x cable comes in different lengths, specified by the part number extension to the type of cable desired.

Part No. Extension	Length
-05	5 m (16.4 ft)
-10	10 m (32.8 ft)
-20	20 m (65.6 ft)
-40	40 m (131.2 ft)

For example, a BNE3C-20 is a 20-meter (65.6-foot) Teflon, straight connector. For any questions regarding your specific requirements, contact your service representative.

ThinWire Ethernet Components

This section describes the ThinWire Ethernet components you can use to connect your VAXstation II/GPX, using ThinWire Ethernet.

ThinWire Ethernet Cable

The maximum recommended length of cable leading from a terminator to the last station on a segment of ThinWire Ethernet is 185 m (606 ft). At least 0.5 m (1.6 ft) is required between stations.

Connectors

A ThinWire section is a single length of RG58C or equivalent cable. You will need two connectors, one at each end, for each section of ThinWire cable.

Barrel Connectors and T-Connectors

A ThinWire segment is one or more sections of ThinWire cable interconnected by barrel or T-connectors. You need one T-connector for each DESTA and VAXstation II/GPX.

DESTA and Transceiver Cable

If you want to connect a VAXstation II/GPX or any devices like the bridge, repeater, or server that use transceiver cables to connect to ThinWire Ethernet, you will need a DESTA and a transceiver cable.

Terminators

You need one terminator for each end of a ThinWire segment.

Connectors and Terminators

The ThinWire connectors and terminators you need to configure your ThinWire network follow:

- **T-connector (H8223)**—A 3-way connector that joins two ThinWire Ethernet cable sections. The third opening attaches to the system unit.
- **Terminator (H8225)**—A connector at the end of a ThinWire segment that provides the 50-ohm termination resistance needed for the cable. If the ThinWire cable connects to a DIGITAL ThinWire Ethernet Multiport Repeater (DEMPR), then a terminator is only needed at one end of the cable.
- **Barrel connector (H8224)**—A recessed connector that connects two ThinWire Ethernet cable sections.

Figure 4-8 shows the connectors and terminator you need to connect to ThinWire Ethernet.

Figure 4-8: Connectors

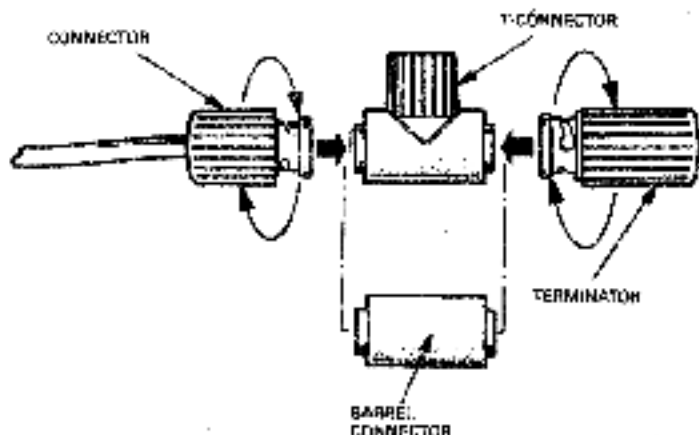

DEC 1991-06

Additional Equipment

Use the following equipment to connect a system with a transceiver cable to ThinWire Ethernet:

- DIGITAL ThinWire Ethernet Station Adapter (DESTA-AA)

DIGITAL ThinWire Ethernet Station Adapter (DESTA)

The DESTA is an Ethernet/IEEE 802.3 transceiver that connects systems that have transceiver-type connectors to ThinWire Ethernet. A transceiver is a device that provides a single physical connection between standard Ethernet and Ethernet communication equipment.

The DESTA has two ports: one port connects to the T-connector connected to ThinWire, a second port connects a transceiver cable that leads to the system.

Figure 4-9 shows a DESTA.

The DESTA provides:

- Connection of a system with a transceiver cable to ThinWire Ethernet.
- Attachment to devices connected to Ethernet communication controllers by way of transceiver cables.

Figure 4-9: DIGITAL ThinWire Ethernet Station Adapter (DESTA)

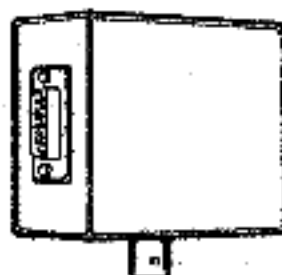

4-2-71 88

For more information on these options, see the following documents:

- *DEQNA User's Guide* (Order No. EK-DEQNA-UG)
- *MicroVAX Handbook* (Order No. EB-25156-47)
- *DELNI Installation and Owner's Manual* (Order No. EK-DELNI-IN)
- *Ethernet Installation Guide* (Order No. EK-ETHER-IN)

Modems

Four modems are available for use with the VAXstation II/GPX:

Modem	Description
DF224	300, 1200, and 2400 bps (bits per second) full-duplex synchronous/asynchronous
DF124	1200 and 2400 bps full-duplex synchronous/asynchronous
DF112	300 and 1200 bps full-duplex synchronous/asynchronous
DF03	300 and 1200 bps full-duplex synchronous/asynchronous

DF224

The DF224 modem provides full-duplex communication at speeds of 300, 1200, and 2400 bps (asynchronous) and 1200 and 2400 bps (synchronous). The DF224 allows both rotary pulse and pushbutton dialing over dial-up or leased-line networks.

The DF224 contains an auto-dialer with memory and provides autoanswer capability in addition to manual operation. A data/talk switch and automatic adaptive equalizer are also provided. The DF224's diagnostics test the modem at each power up.

DF124

The DF124 modem provides full-duplex communication at speeds of 1200 and 2400 bps (asynchronous and synchronous) over dial-up or leased-line networks. The DF124 contains an autodialer with memory, a data/talk switch, and diagnostic self-tests.

DF112

The DF112 modem communicates at 300 and 1200 bps full-duplex (asynchronous and synchronous) over dial-up or leased-line networks. An auto-dialer with memory and data/talk switch are provided. The DF112 is compatible with rotary dial and pushbutton dialing.

DF03

The DF03 modem is a 300 and 1200 bps full duplex (asynchronous and synchronous) modem.

To order a modem after initial system installation, contact your sales representative.

The DZQ11 Asynchronous Multiplexer

The DZQ11 is an asynchronous multiplexer that connects the Q22-bus with up to four asynchronous serial data communications channels. A dual-height module, the DZQ11 connects *hard-copy* and *video terminals*, with or without modems, to a system. With a VAXstation II/GPX, the DZQ11 can also be used as an asynchronous DECnet link. The DZQ11 allows dial-up (auto-answer) operations with modems capable of full-duplex operation, such as DIGITAL's models DF03, DF112, DF124, and DF224.

The DZQ11 provides flexible control of parameters, such as baud rate (50 to 9600), character length, number of stop bits for each line, odd or even parity for each line, and transmitter-receiver interrupts. Additional features include limited data set control, break generation and detection, and silo buffering of received data.

To order a DZQ11 after the initial system installation, contact your sales representative. You will need to order a base module (DZQ11-M) and a cabinet kit (CK-DZQ11-DA). Contact your service representative to install the DZQ11.

For more information about the DZQ11, see:

- *DZQ11 Asynchronous Multiplexer User's Guide* (Order No. EK-DZQ11-UG-001)

The DHV11 Asynchronous Multiplexer

The DHV11 is an asynchronous multiplexer that connects up to eight serial lines to a Q-bus for data communications.

The DHV11, a quad-height module with programmable functions, connects hard-copy and video terminals to the VAXstation II/GPX. The DHV11 allows dial-up (auto-answer) operations with modems capable of full-duplex operation, such as DIGITAL's modems DF03, DF112, DF124, and DF224.

Applications for the DHV11 cover data concentration, terminal interfacing, and cluster controlling. The features include full modem control, DMA or sio output, sio input buffering, programmable split speed, and module throughput of 1500 characters/second.

To order a DHV11 after the initial system installation, contact your sales representative. You will need to order a DHV11 base module (DHV11-M) and cabinet kit, which includes filter connectors and cables (CK-DHV11-AB). Contact your service representative to install the DHV11.

For more information about the DHV11, see:

- *DHV11 Technical Manual* (Order No. EK-DHV11-TM-001)

The DMV11 Synchronous Line Controller

The DMV11 is a high-performance controller that operates at speeds up to 56 kilobytes/second to provide efficient synchronous communications for distributed networks.

Point-to-point configurations are practical when terminals have a high message rate. However, the message rate of the terminals is usually very low, even though the bit rate might be quite high. In those cases, sharing a transmission line can significantly reduce the cost and improve the efficiency of a communications network.

You will need to order a base module (DMV11) and one of four cabinet kits. The DMV11 cabinet kit option you choose depends on the interface requirements of your system.

NOTE: *The RS-232-C standard has been superseded by the EIA-232-D standard.*

The four DMV11 cabinet kit options are:

1. CK-DMV11-AA

- M8053-M Microcontroller/line unit (a quad-height module with multipoint microcode)
- H3254 (V.35 or integral modem) Module test connector
- H3255 (RS-423-A/EIA-232-D) Module test connector
- BC08S-1K Cable
- H325 and H3251 Cable turnaround test connector
- 70-20863-00 3.2 x 2.6 Panel

2. CK-DMV11-BA

- M8053-M Microcontroller/line unit (a quad-height module with multipoint microcode)
- H3254 (V.35 or integral modem) Module test connector
- H3255 (RS-423-A/EIA-232-D) Module test connector
- BC17E-25 Cable
- H3250 Cable turnaround test connector
- 70-20861-1K Panel

3. CK-DMV11-CA

- M8064-M Microcontroller/line unit (a quad-height module with multipoint microcode)
- H3254 (V.35 or integral modem) Module test connector
- 7018250-1K Cable
- H8568 and H8570 Terminators
- 70-20862-00 Panel

4. CK-DMV11-FA

- M8053-M Microcontroller/line unit (a quad-height module with multipoint microcode)
- H3254 (V.35 or Integral modem) Module test connector
- H3255 (RS-423-A/EIA-232-D) Module test connector
- BC085 Cable
- H3251 Cable turnaround test connector
- 70-20864-00 Panel

To order a DMV11 after the initial system installation, contact your sales representative. Contact your service representative to install the DMV11.

For more information about the DMV11 synchronous line controller, see:

- *DMV11 Synchronous Controller User's Guide* (Order No. EK-DMV11-UG)

The DPV11 Synchronous Line Controller

The DPV11 is a low-cost single-line programmable interface that operates at speeds up to 56 kilobytes/second to provide efficient synchronous communications for distributed networks.

The DPV11 is suited for interfacing to medium-speed synchronous lines for remote batch and remote job-entry applications. The DPV11 is compatible with DIGITAL's family of modems and with the Bell 200 Series modems and their equivalents.

To order a DPV11 after the initial system installation, contact your sales representative. Contact your service representative to install the DPV11.

For more information about the DPV11, refer to the following document:

- *DPV11 Technical Manual* (Order No. EK-DPV11-TM)

The KMV11 Programmable Controller

The KMV11 is a high-performance direct memory access single-line programmable communications controller that operates at up to 64 kilobytes/second to provide efficient synchronous or asynchronous communications for distributed networks.

The KMV11 performs user-defined communications functions, thereby freeing the host to do more application computations.

The KMV11 can be programmed in synchronous or asynchronous modes. It also provides full modem support for DIGITAL's family of modems, the Bell 200 Series or equivalent, and European PPT-approved modems.

To order a KMV11 after the initial system installation, contact your sales representative. Contact your service representative to install the KMV11.

For more information about the KMV11, refer to the following document:

- * *KMV11 Programmable Communications Controller Technical Manual* (Order No. EK-KMV11-TM)

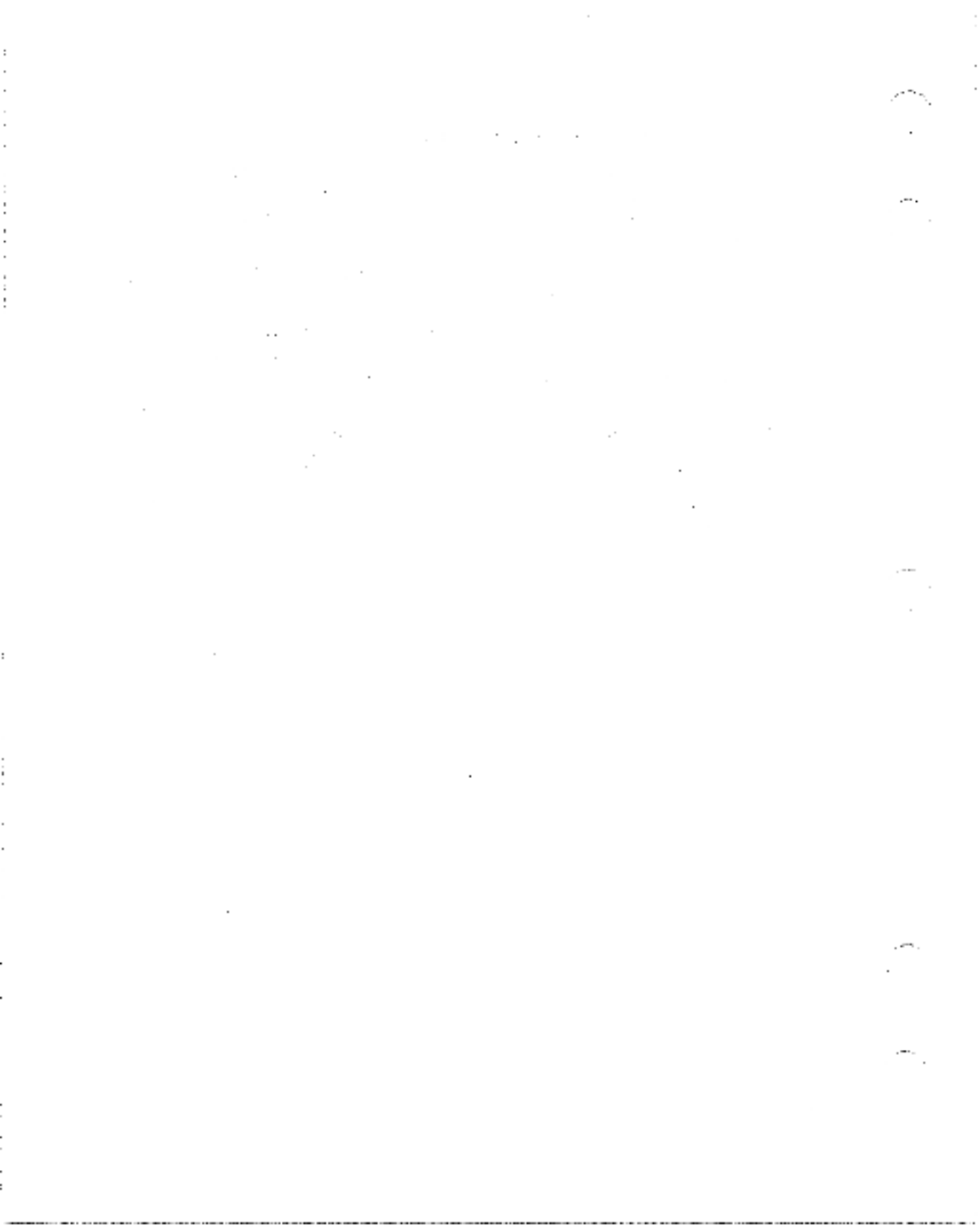

Chapter 5

Troubleshooting Procedure

This chapter, divided into three parts, provides troubleshooting information for the VAXstation II/GPX:

- **POWER-UP MESSAGES**—discusses the indications that appear when the system is turned on.
- **BASIC TROUBLESHOOTING**—provides a checklist of potential minor problems with the system unit, fixed disk and diskette drives, tape drive, pointing device and monitor, and corrective actions you can take.
- **MICROVAX DIAGNOSTIC MONITOR (MDM)**—describes the VAXstation II/GPX "MicroVAX Diagnostic Monitor System" (MDM) software tests and the "Main Menu" maintenance options.

NOTE: *If you have a diskless system that contains neither a TK50 tape drive nor a floppy diskette drive, contact your service representative for additional system troubleshooting and diagnostics.*

Power-up Messages

During the power-up sequence, the VAXstation II/GPX executes built-in diagnostic and *bootstrap* routines that provide maintenance information. The information is displayed in single letters and numbers on both the light-emitting diode (LED) display, located on the CPU distribution panel on the back of the VAXstation II/GPX system unit, and on the monitor screen. Normally, the display progresses from F to 0 (going from F to A and then 8 to 0). A problem exists if the display stops in the F to 0 range.

- If the display stops in the F to 3 range, a hardware error might exist in the VAXstation II/GPX system. Contact your service representative.
- If the display stops on A, check the keyboard connection and the pointing device connection. (See Setting Up the Keyboard and Pointing Device section in Chapter 2.)
- If the display stops on 2, check the "system does not boot from..." problem indications listed in Table 5-1.

- If the display stops on 1, the bootstrap device might not contain bootable system software. Complete the system software installation as directed in the documentation supplied with your system software.

Basic Troubleshooting

Tables 5-1 through 5-5 list causes and corrective actions for minor system problems that you can fix. The basic troubleshooting procedures are separated into system unit, tape drive, fixed disk and diskette, and monitor problems.

If the corrective action does not work or the problem is more serious, run the MicroVAX Diagnostic Monitor (MDM) system software to isolate the problem (see the Maintenance System section of this chapter) and contact your service representative.

Monitor fuse replacement instructions and mouse maintenance procedures follow Table 5-5.

Table 5-1: System Unit Troubleshooting Procedures

Power Up

Problem	Possible Cause	Corrective Action
No response when the power switch is turned to 1 (on).	System is not plugged in.	Set the power switch to 0 (off). Plug in the system. Set the power switch to 1 (on).
	Wall outlet is faulty.	Use a different wall outlet.
	System circuit breaker is tripped.	Set the power switch to off. Reset the circuit breaker by pressing down and then pulling up the circuit breaker lever. (See Figure 5-1.) Set the power switch to on. If the circuit breaker trips again, contact your service representative.

Figure 5-1: System Circuit Breaker

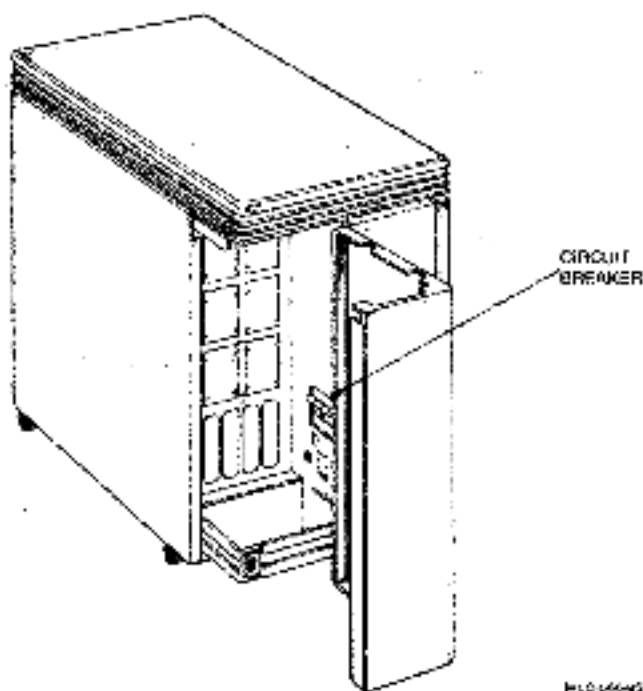

Table 5-1 (Cont.): System Unit Troubleshooting Procedures**Power Up**

Problem	Possible Cause	Corrective Action
No response when the power switch is turned on.	Power cable is incorrectly installed.	Set the power switch to off. Check that the cable is fully seated into the socket in the back of the system. Set the power switch to 1 (on).
Power is on, but the display on the monitor does not appear.	Monitor is off.	Turn on the monitor.
	Monitor cable is incorrectly installed.	Make sure that the monitor cable is installed properly. (See Chapter 2.)
	Brightness and contrast controls are not set properly.	Adjust brightness and contrast controls.
	Rear panel LED display indicates a power-up error.	Insert bootable system software diskette.
	Keyboard cable installed incorrectly.	Make sure the keyboard cable is installed properly. (See Chapter 2.)
Instead of automatically booting when the power switch is turned on, the arrow prompt (>>>) is displayed on the monitor.	A keyboard key or pointing device pushbutton is accidentally pressed during a system boot.	Remove anything that may be activating these devices and reboot the system.
	The Halt Enable/Disable switch is set to the Enable position (the system is set to console mode).	Type B DUA0 and press the Return key to boot the system. Or, exit console mode by setting the Halt Enable/Disable switch to the disable (down) position and then press the Restart pushbutton to have the system boot automatically.
Monitor displays the message 754 RETRY when the system diagnostics are running.	You failed to insert a system diagnostic medium into the load device in the time allotted.	Press the Restart pushbutton to reboot the system. Insert a diagnostic medium.

Table 5-1 (Cont.): System Unit Troubleshooting Procedures**Power Up**

Problem	Possible Cause	Corrective Action
System does not boot from the fixed disk drive.	The Fixed Disk Ready pushbutton is in, or drive is not ready.	Press and release the Fixed Disk Ready pushbutton.
	System software is not on the disk.	Load (install) the system software on the fixed disk, using the system software installation instructions supplied with the software.
System does not boot from the TK50 tape drive.	Fixed Disk Ready pushbutton is not in.	Press in the Fixed Disk Ready pushbutton.
	Tape is worn or damaged.	Try another tape.
	Tape cartridge release handle is not locked.	Press down the cartridge release handle.
	TK50 tape is not fully inserted into the tape drive.	Make sure the tape is fully inserted and the cartridge release handle is locked down.
System does not boot from the diskette drive.	Diskette is not in the diskette drive.	Insert a diskette containing bootable system software in diskette drive 1 and enter the applicable boot command for the device.
	Diskette drive door is open.	Close the diskette drive door.
	Diskette is upside down in the diskette drive.	Align the orange stripe on the diskette with the stripe on the diskette drive.
	Diskette is not bootable.	Use a diskette containing bootable system software.
	Diskette is worn or damaged.	Try another diskette.
	Diskette is write protected.	Remove the foil tab covering the write-protect notch or use a different diskette.

Table 5-1 (Cont.): System Unit Troubleshooting Procedures**Power Up**

Problem	Possible Cause	Corrective Action
System does not re-boot when power switch is pressed off and on.	Power switch was not set in off position for enough time.	Set power switch to off for at least 15 seconds before pressing to the 1 (on) position.

System Halts

Problem	Possible Cause	Corrective Action
System halts unexpectedly during normal operation.	The Halt pushbutton was pressed (the system is in console mode).	Press the Restart pushbutton. Set the Halt Enable/Disable switch to the disable (down) position to prevent unwanted recurrences.

Table 5-2: Fixed Disk and Diskette Drives Troubleshooting Procedures**Read and Write Errors**

Problem	Possible Cause	Corrective Action
Fixed disk read error message is displayed.	Fixed Disk Ready pushbutton is in.	Press and release the Fixed Disk Ready pushbutton.
	Disk is write protected. (Write-Protect pushbutton glows orange)	Press and release the Write-Protect pushbutton so it does not glow.
Fixed disk write error message is displayed.	Disk is write protected.	Press and release the Write Protect pushbutton.
Diskette read error message is displayed.	The diskette drive is empty.	Insert a diskette into the diskette drive.
	Diskette drive door is open.	Close the diskette drive door.
	Diskette is upside down in the diskette drive.	Align the orange stripe on the diskette with the stripe on the diskette drive.

Table 5-2 (Cont.): Fixed Disk and Diskette Drives Troubleshooting Procedures

Read and Write Errors		
Problem	Possible Cause	Corrective Action
Diskette write error message is displayed.	Diskette is not formatted.	Use a preformatted RK50 diskette.
	Diskette is worn or damaged.	Try another diskette.
	The diskette drive is empty.	Insert a diskette in the diskette drive.
	Diskette drive door is open.	Close the diskette drive door.
	Diskette is upside down in the diskette drive.	Align the orange stripe on the diskette with the stripe on the diskette drive.
	Diskette is not formatted.	Use a preformatted RK50 diskette.
	Diskette is worn or damaged.	Try another diskette.
Diskette is write protected.	Remove the foil tab covering the write-protect notch.	

Table 5-3: Tape Drive Troubleshooting Procedures

Problem	Possible Cause	Corrective Action
TK50 passes the power-up test but does not work.	Tape is not in the drive, or the drive is not loaded.	Insert the tape and press the Load/Unload pushbutton.
	Load/Unload pushbutton is out.	Press the Load/Unload pushbutton.
TK50 Load/Unload red indicator flashes rapidly and no unusual sounds are heard.	A problem exists with the tape drive.	Press the Load/Unload pushbutton four times. If the problem persists, do not attempt to use the tape drive or to remove the tape cartridge. Call your service representative.

Table 5-3 (Cont.): Tape Drive Troubleshooting Procedures

Problem	Possible Cause	Corrective Action
Load/Unload indicator flashes rapidly and you hear a whirring sound.	Leaders are not properly coupled.	Immediately turn off the system by pushing the on/off switch to 0 (off). Do not attempt to use the tape drive or to remove the tape cartridge. Call your service representative.
Tape cartridge release handle does not lift.	The power-up test is still in process.	Wait for the Load/Unload indicator to stop glowing and the Tape Activity indicator to glow green. Try again. If the problem persists, call your service representative.
	System power is not on.	Turn on the system power.
Tape cartridge release handle does not lock.	Tape is not inserted properly.	Reinsert the tape cartridge. If the problem persists, call your service representative.
Tape does not unload.	The Load/Unload push-button is in load position.	Make sure the Load/Unload push-button is in the unload position. Wait for the indicator to go out before trying to remove the tape.

Table 5-4: Monitor Troubleshooting Procedures

Problem	Possible Cause	Corrective Action
Power indicator on the front of the monitor does not light green when you turn on the monitor.	Power cord is not connected to the monitor or the wall outlet.	Connect the power cord to the monitor and wall outlet.
	Monitor is not turned on.	Turn on the system and then the monitor.
	No power exists at the wall outlet.	Use another outlet.
	Monitor fuse is blown.	Replace the fuse. See the Replacing the Fuse section.

Table 5-4 (Cont.): Monitor Troubleshooting Procedures

Problem	Possible Cause	Corrective Action
Screen is blank and power indicator on the front of the monitor is lit.	System's CRT saver feature is activated.	Press any key to reactivate the display.
Screen goes blank after successful power up, and the power indicator on the front of the monitor goes out.	Monitor fuse is blown.	Replace the fuse. See the Replacing the Fuse section.
Screen displays raster, but no cursor or text appears.	Signal cable is disconnected.	Secure the video cable connection between the monitor and the system.
	System is not on.	Turn on the system.
	Contrast control is set to minimum.	Turn up the contrast control.
	Host system's CRT saver feature is activated.	Press any key to reactivate the display.
Screen display is distorted, rolling or flickering, or the wrong color appears.	Video cable is incorrectly installed.	Make sure that the video cable is installed properly.
For the color monitor, color is not even; poor color purity.	Electromagnetic interference exists.	Press the degauss switch for a few seconds. After 30 seconds, recheck purity.
		Move any electromechanical device away from the monitor or move the monitor.

CAUTION: Before moving the monitor, turn the monitor off and wait 30 seconds to allow static electricity on the CRT to discharge.

Table 5-5: Pointing Device Troubleshooting Procedures

Problem	Possible Cause	Corrective Action
Mouse does not track properly.	The tracking ball is dirty.	Clean the tracking ball. See the Mouse Maintenance section.
Pointing device indicator does not appear on the monitor screen, or the monitor does not respond to the pointing device commands.	Cable is installed incorrectly.	Unplug and then replug the cable to reset the device. (See Chapter 2.)

Replacing the Fuse

If the Monitor Troubleshooting Procedures (Table 5-4) indicate that you need to replace the fuse for the monitor, follow the instructions.

Color Monitor

The color monitor has an automatic voltage-switching mechanism. Therefore, you do not need to change the **voltage switch** setting. Use either of the following fuses:

- 3AG, a 2-Amp, 250-volt, slow-blow fuse. (DIGITAL part number: 12-14676-04)
- IEC, a 2-Amp, 250-volt, slow-blow fuse. (DIGITAL part number: 12-19283-03)

Figure 5-2: Fuse Location, Color Monitor

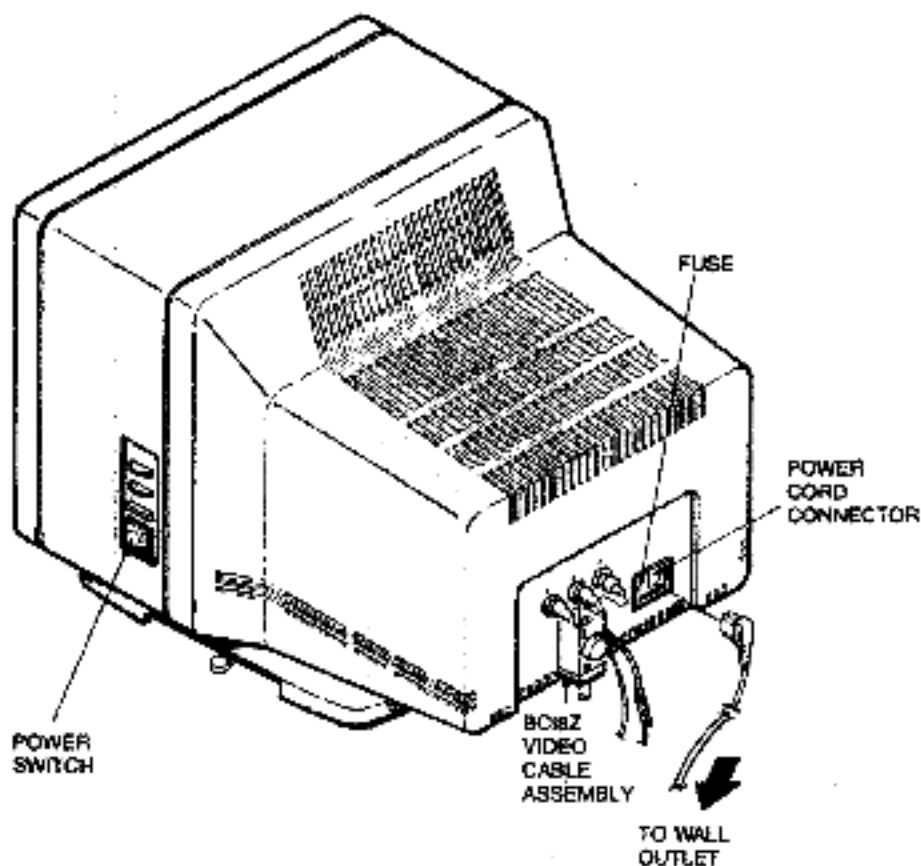

912-877.88

To replace the fuse:

1. Turn off the power and wait 10 seconds to allow the voltage to dissipate.

WARNING: You must wait a full 10 seconds or the voltage may harm you.

2. Unplug the power cord from the wall outlet and then from the monitor.

- Carefully pry out the fuse carrier with a screwdriver.

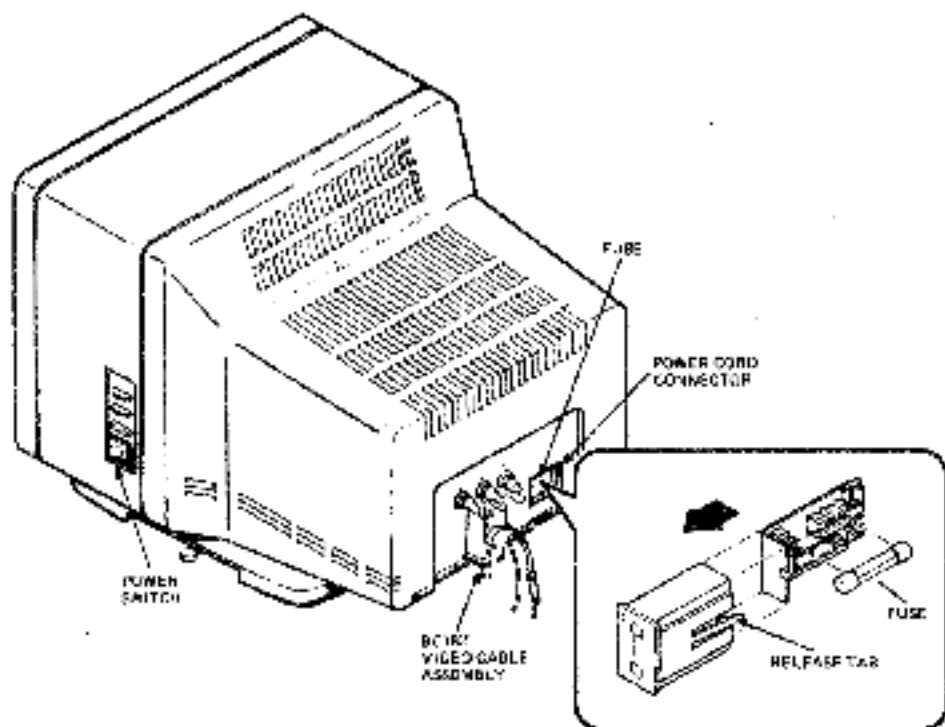

- Carefully pry open the release tab, remove the inner fuse holder, and replace the fuse.
- Replace the inner fuse holder in the fuse carrier.
- Replace the fuse carrier in the back of the monitor.
- Plug the power cord back into the monitor and then into the wall outlet.
- Turn on the power.

Mouse Maintenance

The rubber-coated ball under the mouse can be removed for cleaning or replacement. Clean the ball when the mouse fails to smoothly move the cursor on the screen. In an average office environment, cleaning the ball every 6 months is sufficient.

To remove and clean the mouse ball:

1. Turn the mouse upside down. Remove the ball housing cover plate by placing your fingers in the grooves on the plate and turning the plate counterclockwise.

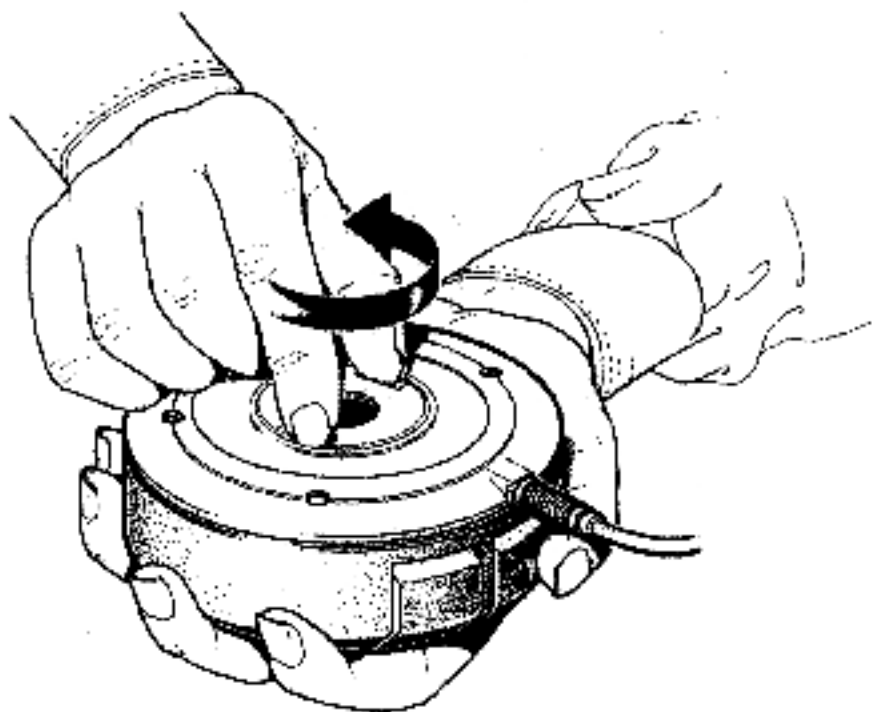

14-0-6662-06

2. Lift off the cover plate and remove the ball.

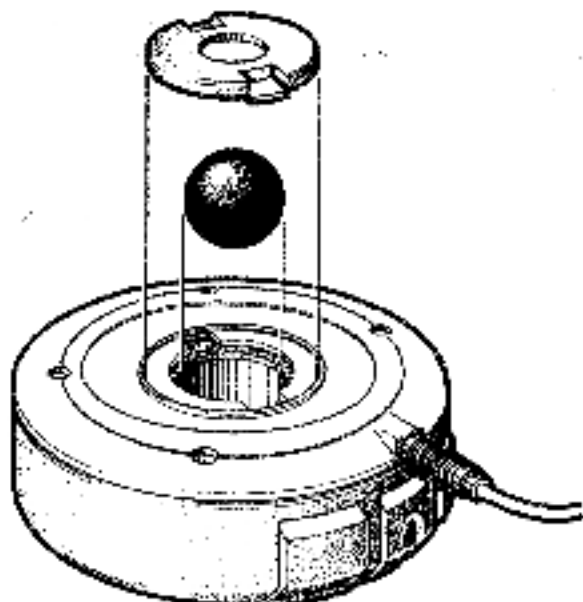

NLO-3045-02

3. Clean the ball with lukewarm water and, if necessary, a mild soap.

CAUTION: Do not use organic solvents such as toluene or trichloroethane, which will damage the rubber coating.

4. Dry the ball with a soft, lint-free cloth.

5. Replace the ball and cover plate.

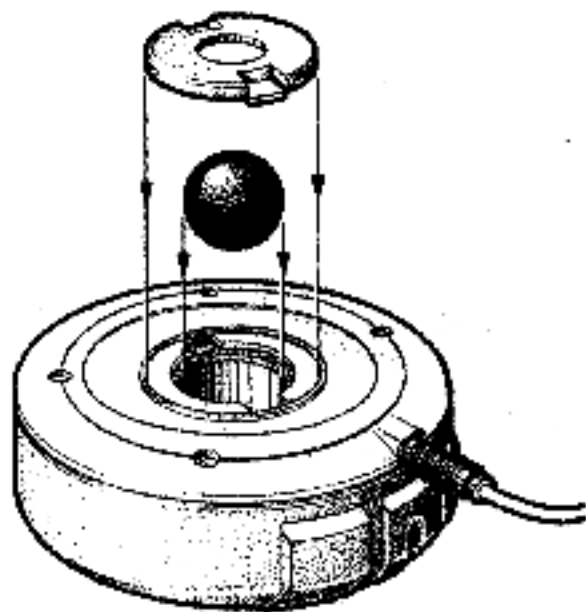

HALQ-9032-00

6. Lock the cover plate into position by placing your fingers into the grooves on the cover plate and turning it clockwise.

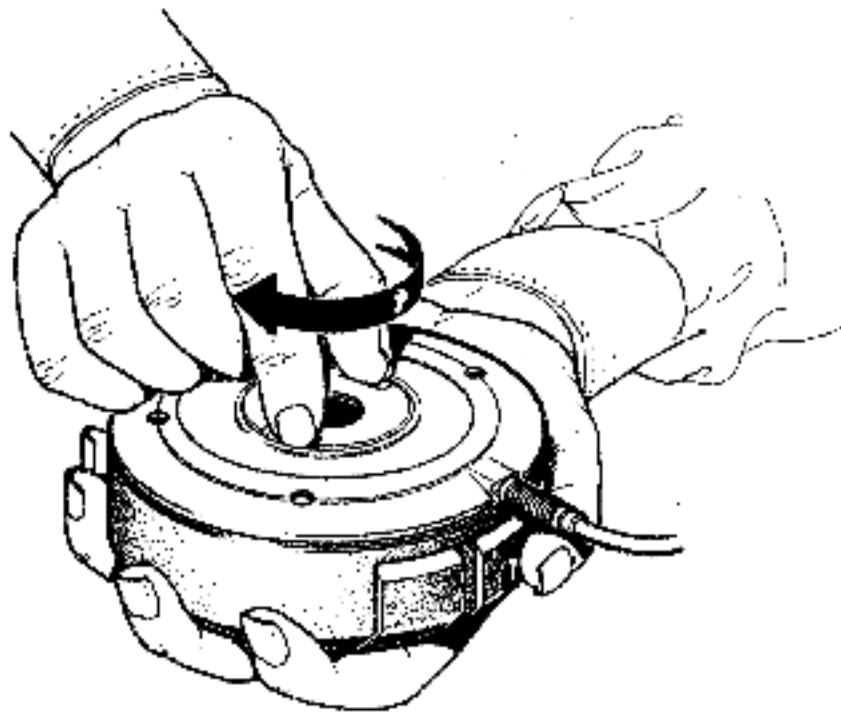

8112-6000-10

MicroVAX Diagnostic Monitor

The "MicroVAX Diagnostic Monitor" (MDM) system software provides user tests that isolate and identify faults in the system. Use this software to test the system in response to an error message or to test your system periodically. Test the system (and record the results) before calling your service representative.

In addition, the maintenance software displays list system utilities and system devices.

The maintenance software is stored on RX50 diskettes or on a TK50 cartridge. To run the maintenance programs and to call VAXstation II/GPX system displays, use the monitor and keyboard for command inputs.

The MicroVAX Diagnostic Monitor Main Menu

The "MicroVAX Diagnostic Monitor Main Menu" display lists the testing options. See the Checking the System section of Chapter 2 for instructions on accessing the "Main Menu."

Press the RETURN key to continue. >

MAIN MENU

- 1 -- Test the system
- 2 -- Display System Configuration and Devices
- 3 -- Display the System Utilities Menu
- 4 -- Display the Service Menu
- 5 -- Exit MicroVAX Diagnostic Monitor

Type the number; then press the RETURN key. >

The following maintenance system options appear in the "Main Menu" in the previous picture:

- 1—Test the System. This option tests the devices supplied by DIGITAL for a VAXstation II/GPX system. See the Checking the System section of Chapter 2 for instructions on testing devices.

- 2—Display System Configuration and Devices. This option displays a list of the devices supplied by DIGITAL for a VAXstation II/GPX system. A sample screen is shown in the following illustration. Your configuration might be different from this example.

Type the number; then press the RETURN key. >2

SYSTEM CONFIGURATION AND DEVICES

SYSTEM CONFIGURATION

```

CPUA..MicroVAX CPU
      KA630-AA 1MB, FPU NDO HDU
MEMA..MicroVAX memory system
      2 megabytes, 4096 Pages.
      KA630...CPU module, 1MB on-board memory.
      NS630-AA...Dual height memory module, 1MB.
RQDKA...Winchester/diskette controller.
      Revisions=10 and 6
      ... cannot identify drive, Offline.
      RK50...Removable
      RK50...Removable
DEQVAA...Ethernet controller.
      OB-00-2B-02-17-D3
VCBO2A...Graphics Processing Extension
  
```

Press the RETURN key to return to the previous menu. >

NOTE: The last letter in each device listed differentiates among multiple devices of the same type. For example, DEQVAA indicates one DEQVA module; DEQVAB a second, and so forth.

NOTE: When you have two of the 8-megabyte memory options (MS630-CA) installed, you receive a message that the 1-megabyte of memory on-board the CPU is disabled. This message does not indicate an error. VAXstation II/GPX systems have a 16-megabyte limit on physical memory.

- 3—Display the System Utilities Menu, which allows you to format your fixed disk.
- 4—Display the Service Menu. This option displays the Field Service diagnostics. Only your service representative should use this menu. (See the VAXstation Maintenance Guide for additional information.)
- 5—Exit MicroVAX Diagnostic Monitor. This option allows you to exit from the "Diagnostic Monitor".

The System Utilities Menu

The only option in this menu is the Customer Disk Drive Formatter. This option allows you to format a fixed disk or a diskette. Your fixed disk or diskette must be formatted before you can use it to store data.

CAUTION: *Formatting a fixed disk or diskette destroys all data on the disk or diskette. Use the formatting utility only if you have made copies of any data on the disk you want to save or the disk is empty.*

To format a system fixed disk or a diskette in the diskette drives with the screen displaying the System Utilities screen:

1. Type 1 and press the RETURN key.
2. If you are formatting a fixed disk you are prompted to write-protect all the drives except the one you want to format. Push the write-protect pushbutton to make sure that it is in the out (write-enable) position on the drive control panel.
3. If you are formatting a diskette, remove the write-protect foil tab on the diskette and insert the diskette into the diskette drive.
4. Press the RETURN key. The screen displays a list of the drives and their unit numbers and prompts you for the number of the unit (drive) you want to format.
5. Type the number of the unit and press RETURN. You are asked to verify the unit number.
6. If the unit number is correct, type 1 and press the RETURN key. If the unit number is incorrect, type 0 and enter the correct unit number.

The screen displays status messages as the formatting continues and informs you when the formatting process is complete.

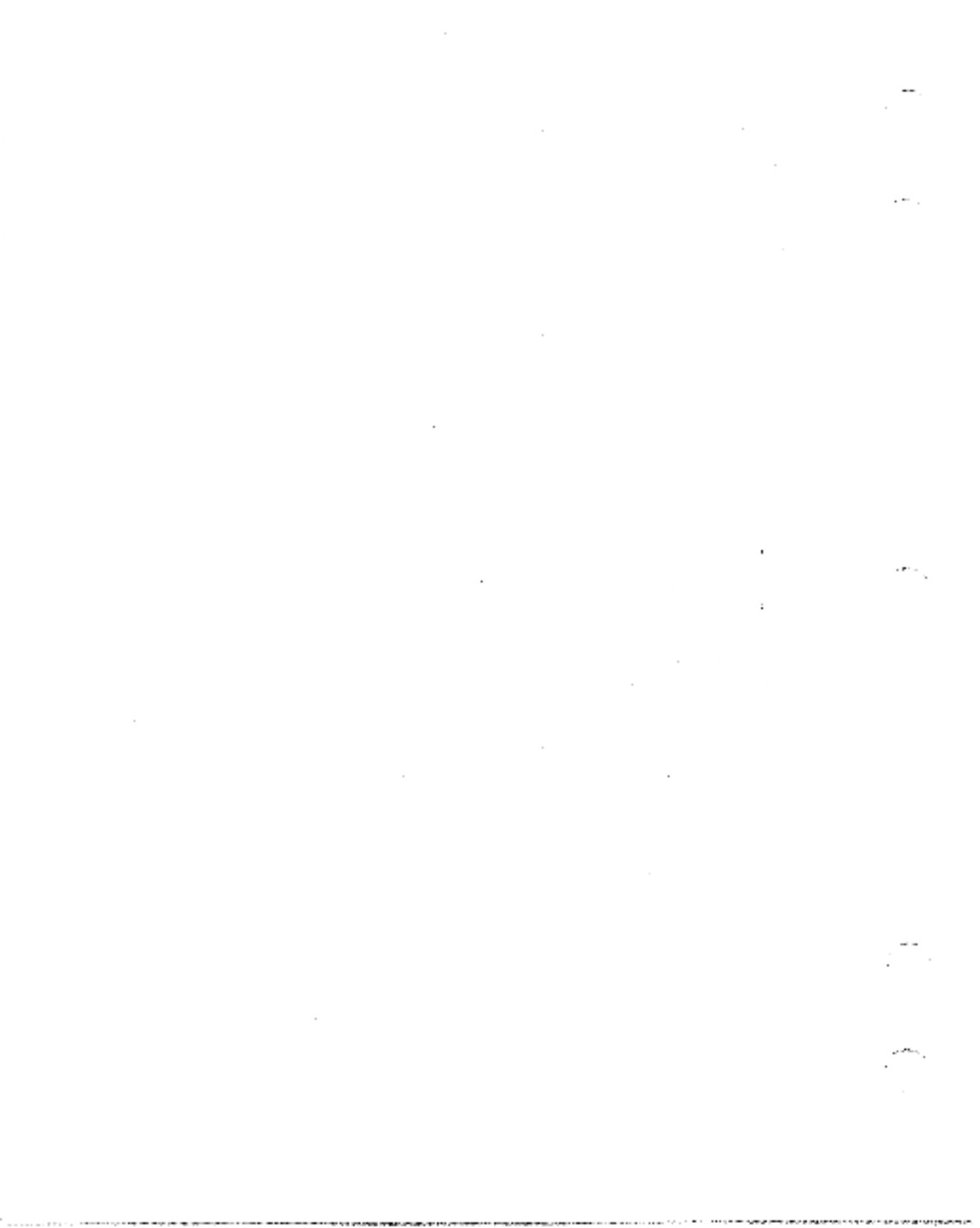

Chapter 6

Service

If you are unable to correct a problem with your VAXstation II/GPX system, contact your service representative.

How to Call for Service

Before you call:

1. Check the problem-solving suggestions listed in Chapter 5. You can often solve a problem yourself.
2. Write down the serial and model numbers of your VAXstation II/GPX. The numbers are located on the rear panel of the system unit (and on the service tag on system front panel).
3. Summarize the problem. Make a note of what you were doing when the system failed. Note if any indicators turned on or off, or if you heard any new sounds before or after the system failed.

Who you call:

1. Call your service representative. If you are under warranty or have a DIGITAL service contract, you may also call the customer support center for assistance. In the United States, the customer support hot line number is 1-800-DEC-3000. If you are located outside the United States, contact your sales representative for the local service branch office phone number.

When you call:

1. Stay near the VAXstation II/GPX.
2. Have all your materials available (for example, manual, serial and model numbers, and problem summarization). That will assist the service representative with helping you.

NOTE: *If you return the VAXstation II/GPX to DIGITAL for service, repack the system or modules in their original shipping containers.*

DIGITAL Services

Your DIGITAL hardware warranty gives you access to DIGITAL's best resources, including technical expertise, spare parts inventories, and worldwide service.

After warranty, DIGITAL's support continues through optional on-site and off-site services for as long as you own your DIGITAL hardware. DIGITAL's on-site services include fast response time and full support, including the cost of parts and labor. Contact your service representative for a description of the DIGITAL services available in your area.

Appendix A

VAXstation II/GPX System Specifications

Table A-1: System Electrical Requirements

Input	Specifications ¹	
	120 V ac	220 V ac
Voltage range	88-128 V	176-256 V
Power source phasing	single	single
Frequency	60 Hz	50 Hz
Line frequency range	47-63 Hz	47-63 Hz
Running current (typical)	8.8 A	4.4 A
Power consumption (maximum)	690 W	690 W

¹These requirements depend on the line voltage setting that you select.

Table A-2: System Environmental Requirements

	Operating	Nonoperating
Maximum altitude	2400 m	12000 m
Temperature range ¹	15–32 deg. C (60–90 deg. F)	-40–60 deg. C (-40–140 deg. F)
Relative humidity	20%–80%	10%–95%

¹Reduce the maximum temperature specification by 1.8 degrees Celsius (3.24 degrees Fahrenheit) for each 1000-meter increase in altitude.

NOTE: Your service contract may require limits for temperature and humidity that override the limits listed above.

Table A-3: Color Monitor Specifications

Description	Characteristics
Physical	
Height	47 cm (18.5 in)
Width	51.8 cm (25 in)
Depth	34.6 cm (21.5 in)
Weight	Approximately 41 kg (90 lb)
Picture Tube Size Diagonal	
	480 mm (19 in) viewable
Video Format	
	RGB color, composite video
Display Characteristics	
	0.31 mm dot pitch with high efficiency antiglare treatment
	1024 x 864 pixels, giving approximate picture size of 326 x 275 mm
Timing	
Vertical rate	60 Hz
Horizontal rate	54 KHz

Table A-3 (Cont.): Color Monitor Specifications

Description	Characteristics
Video R and B Input Signals	0.7 V pp/75 Ohm
Video G Composite Signal	1 V pp/75 Ohm
Power	
AC input	88-132 V, 50/60 Hz 185-264 V, 50 Hz
Power consumption	150 W (nominal)
Fuse (either may be used)	2A, 250 V slow blow (3AG) DIGITAL part no. 12-14676-04 2A, 250 V slow blow (IEC) (European designation T2A-250 volt) DIGITAL part no. 12-19283-03
External Controls	Contrast Brightness Degauss Tilt-lock lever On/off
Operating Temperature Range	10-40 deg. C (50-104 deg. F)
Humidity	10%-95% relative humidity, noncondensing

Table A-4: Mouse Specifications

Description	Characteristics
Physical	
Height	4 cm (1.57 in)
Diameter	8.8 cm (3.47 in)
Weight	0.82 kg (0.37 lb)
Cable	1.5 m (5 ft) in length, 0.38 cm (0.15 in) diameter, six conductors, shielded, high flexibility design
Connector	7-pin Micro-DIN type (male)
Temperature	
Operating	10-40 deg. C (50-104 deg. F)
Nonoperating	-40-66 deg. C (-104 deg. F-140 deg. F)
Electrical	
Power	+5 V +/-5% at 130 mA -12 V +/-10% at 20 mA (serial)
Interface	RS-232 voltage level compatible TTL compatible
FCC/EMI	Class B certified

Table A-4 (Cont.): Mouse Specifications

Description	Characteristics
Performance	
Resolution	79 counts/cm 250 counts/in
Tracking speed	75.5 cm/sec (30 in/sec)
Accuracy	+/-3% 0-24.5 cm/sec (0-10 in/sec) any direction +/-15% 24.5-49 cm/sec (10-20 in/sec) any direction +/-30% 49-73.5 cm/sec (25-30 in/sec) any direction
Operating	
Modes	Incremental Stream Prompt
Data format	Delta Binary
Sampling rate	55 reports/sec in Incremental stream mode, up to 95 reports/sec when polling
Baud rate	4800 baud
Pin assignments	
Pin	Function
1	ground
2	transmit data
3	receive data
4	-12 V
5	+5 V
6	not used (+12 V)
7	not used
shell	protective ground

Table A-5: Tablet Specifications

Description	Characteristics
Physical	
Construction	Molded, high-impact plastic
Finish	Fine matte finish to minimize glare and fingerprints
Color	Light gray

Table A-5 (Cont.): Tablet Specifications

Description	Characteristics
Power/signal cable	1.5 m (5-foot) cable wired to tablet, terminated in a 7-pin Micro-Din connector
Height	2 cm (0.8 in)
Width	41.2 cm (16.2 in)
Length	40.6 cm (16 in)
Weight	3.2 kg (7 lb)
Performance	
Resolution	79 counts/mm 250 counts/in
Active area	279 mm x 279 mm (11 in x 11 in)
Proximity (Nominal)	1.27 cm (0.5 in) cursor 0.63 cm (0.25 in) stylus
Interfaces	Serial, asynchronous, full-duplex, with RS232C signal levels
Sampling Rate	55, 72, or 120 pairs/sec
Data Rate	4800 or 9600 baud (software selectable)
Coding	Binary 5-byte format. The first byte contains synchronization, pushbutton status, and proximity information. Second and third bytes have absolute X coordinate positions. The fourth and fifth bytes have absolute Y coordinate positions. Each byte is found by one start bit and one stop bit. The data byte contains 8 bits of data and 1 bit for parity (odd parity).
Coordinate origin	Lower left corner of active area
Operating Modes	
Remote request	X-Y coordinate update and proximity report when polled by host
Incremental	Position reports are generated as long as cursor is in motion. Reports are also generated when the pushbuttons are pressed or released.
Diagnostics	Built-in diagnostics that check electronics, communication, tablet, and transducers

Table A-5 (Cont.): Tablet Specifications

Description	Characteristics
Interface	
Description	EIA RS232C compatible signals
Power requirements	+ 12 V dc +/-10% at 0.3 A
Output connector (Power and Data)	7-Pin Micro-Din (male)
Mating connector	7-Pin Micro-Din (female)
Pin assignments	7 Pin (RS232C)
Pin	Function
1	signal and power signal
2	transmit data (from tablet)
3	receive data
4	not used
5	not used
6	+12V
7	tablet present

Table A-6: RD53 Fixed Disk Drive Specifications

Description	Characteristics
Storage	
Total capacity	71,303,168 bytes
User capacity	70,987,776 bytes
User capacity	138,648 blocks
Performance¹	
Average seek time	30 msec
Average rotational latency	8.33 msec
Average access time	38.33 msec
Transfer rate	184.32 kb/sec
Physical	
Height	8.25 cm (3.25 in)
Width	14.6 cm (5.75 in)
Depth	20.32 cm (8 in)
Weight	3.18 kg (7 lb)

¹When operating with RQDX3 controller

Table A-7: RD54 Fixed Disk Drive Specifications

Description	Characteristics
Storage	
Total capacity	191 mbytes
User capacity	159 mbytes
User capacity	310,550 blocks
Performance¹	
Average seek time	30 msec
Average rotational latency	8.33 msec
Average access time	38.3 msec
Transfer rate	5 mb/sec
Physical	
Height	8.255 cm (3.38 in)
Width	14.60 cm (5.75 in)
Depth	20.32 cm (8.10 in)
Weight	2.8 kg (6.3 lb)

¹When operating with RQD43 controller

Table A-8: RX50 Dual Diskette Drive Specifications

Description	Characteristics
Medium	
Diskettes/RX50 drive—2	
Recording surfaces/ diskette—1	
Storage capacity	
Per diskette (80 tracks)	409,600 bytes
Per track (10 sectors)	5120 bytes
Per sector (1 logical block)	512 bytes
Performance¹	
Average seek time	164 msec
Average rotational latency	100 msec
Average access time	264 msec
Transfer rate	12.8 kb/sec

¹When operating with RQD43 controller

Table A-8 (Cont.): RX50 Dual Diskette Drive Specifications

Description	Characteristics
Physical	
Height	8.3 cm (3.25 in)
Width	14.6 cm (5.75 in)
Depth	21.6 cm (8.50 in)
Weight	2.8 kg (4.18 lb)

Table A-9: TK50 Tape Drive Specifications

Description	Characteristics
Medium	
Magnetic tape	
Dimensions	1.27 cm (0.5 in) wide 183 m (600 ft) long
Mode of operation	Streaming
Read/Write method	Serpentine
Recording density	16,934 bits/cm (6667 bits/in)
Number of tracks	22
Capacity	
Unformatted	131 mb
Formatted	94.5 mb
Performance	
Tape start time	300 msec maximum
Tape speed	190.8 cm/sec (75 in/sec)
Streaming data rate	500 kb/sec
Access time	1 min minimum
(from insertion of a new tape)	35 min maximum
Physical	
Height	8.25 cm (3.25 in)
Width	14.60 cm (5.75 in)
Depth	21.44 cm (8.44 in)
Weight	2.27 kg (5 lb)

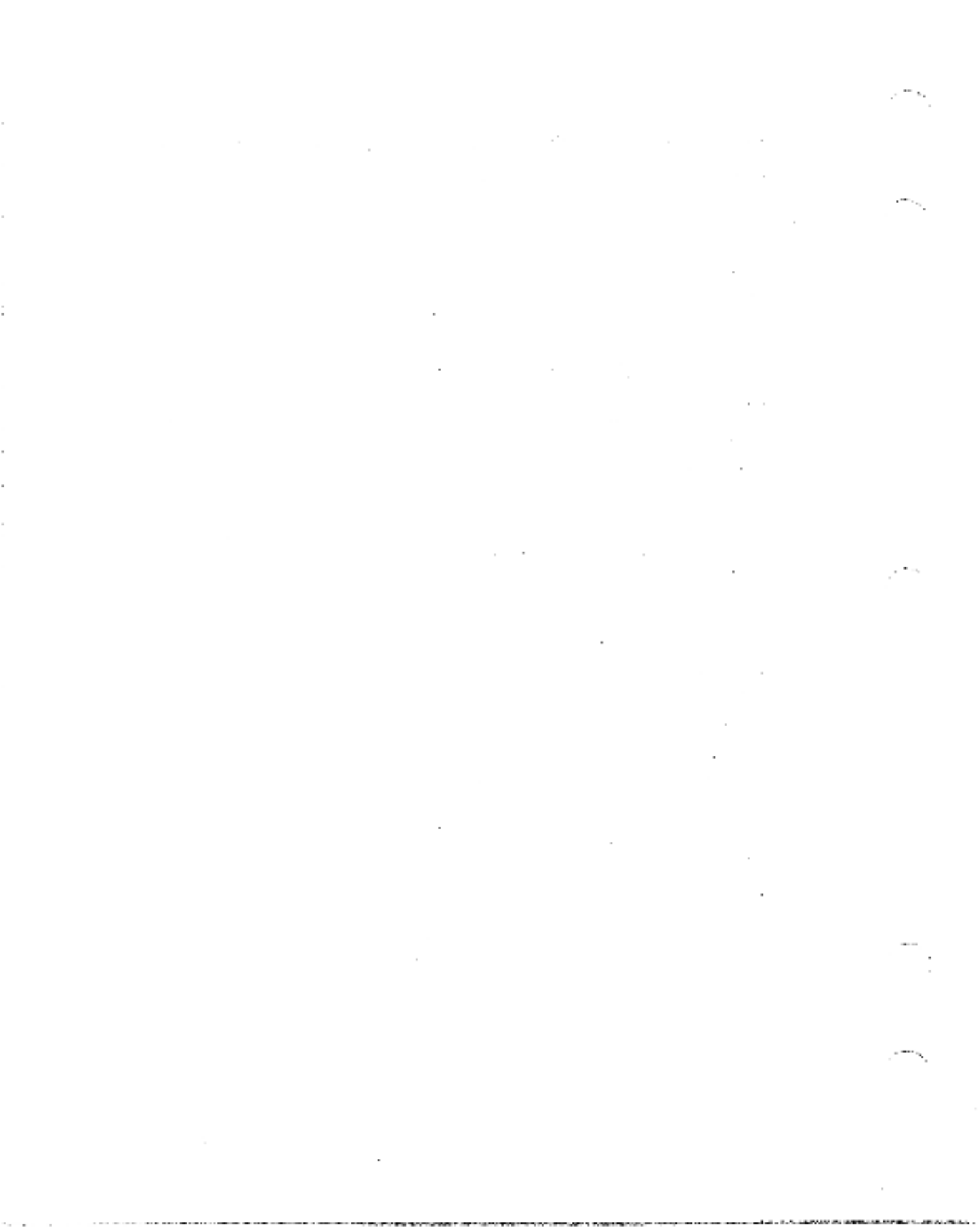

Appendix B

VAXstation II/GPX Related Documents

This appendix lists and describes documents pertaining to a VAXstation II/GPX system in the BA123 enclosure.

The first section deals with hardware. Sections on ULTRIX software and MicroVMS software follow. Refer to the software section applicable to your system. Each software section lists both operating system and workstation documentation.

The last page of this book provides information on ordering documentation.

Hardware

- *BA123 Site Preparation and Verification Guide* (Order No. EK-BA123-SP) provides planning information for system installation. The guide contains space, power, and environmental suggestions.
- *VCB02 Video Subsystem Technical Manual* (Order No. EK-104AA-TM) describes the operation and programming of the VCB02 module. The manual is packaged in the same binder as this book.
- *MicroVAX II Maintenance Kit* (Order No. ZNAEX-GZ)
- *VR290 Color Video Monitor Installation/Owner's Guide* (Order No. EK-VR290-IN) describes how to install, operate, and troubleshoot the color monitor.
- *Mouse Installation Sheet* (Order No. EK-VSXXA-IN) explains how to set up the mouse.
- *Tablet Installation Guide* (Order No. EK-VSXXB-IN) explains how to set up the tablet.
- *KA630-A CPU Module User's Guide* (Order No. EK-KA630-UG) details the internal operation of the MicroVAX KA630-A CPU.

- *MicroVAX II Maintenance Information Kit* (Order No. ZNA3X-C3) explains how to service systems.

ULTRIX Software

- *ULTRIX-32m Documentation Kit Overview* (Order No. AV-CN33C-TE) describes the ULTRIX-32m documentation set. You may order the entire ULTRIX-32m documentation set as a unit (Order No. QZ832-GZ).
- *ULTRIX-32m Release Notes* (Order No. AA-CN34C-TE) contains information about last-minute changes to the software and documentation.
- *ULTRIX-32m Installation Guide* (Order No. AA-CN29C-TE) describes the ULTRIX-32m operating system installation procedure for a system that includes a MicroVAX processor.
- *ULTRIX-32m System Manager's Guide* (Order No. AA-CN28C-TE) contains information for the person responsible for operation and care of a system running ULTRIX-32m.
- *ULTRIX-32m Programmer's Manual Section 1* (Order No. AA-CN25C-TE) describes the commands accessible to all system users.
- *ULTRIX-32m Programmer's Manual Section 2 and 3* (Order No. CN26C-TE) explains systems calls and subroutines of interest to system programmers.
- *ULTRIX-32m Programmer's Manual Section 4, 5, 7, and 8* (Order No. CN27C-TE) describes special system files, file formats, macro packages and conventions, and system maintenance commands.
- *ULTRIX-32m Master Index* (Order No. AA-CN36C-TE) allows fast access to information in the ULTRIX-32m documentation set. Individual indexes are included in each book.
- *ULTRIX-32m Supplementary Documents Volume I* (Order No. AA-CN30A-TE), *ULTRIX-32m Supplementary Documents Volume II* (Order No. AA-CN31B-TE), and *ULTRIX-32m Supplementary Documents Volume III* (Order No. AA-CN32A-TE) contain articles about various components of the ULTRIX system. Programmers who designed the components wrote these articles. Some of the material in these volumes may be partially

¹ These documents pertain only to customers in the United States. If you are not a U.S. customer or if you require translated documents, check the appropriate country's product listing.

inaccurate or dated. These articles are provided to augment the reference and task-oriented information contained in the other ULTRIX-32w documentation.

- *ULTRIX-32w Documentation Kit Overview* lists the ULTRIX-32w documentation set. You may order the entire ULTRIX-32w documentation set as a unit (Order No. 00-Q4X32-GZ).
- *ULTRIX-32w Technical Summary* (Order No. AA-GT87A-TN) describes the architecture, concepts, and nomenclature of the workstation software.
- *ULTRIX-32w Installation and Management Guide* (Order No. AA-GT88A-TN) discusses the installation and management of the workstation software subsets.
- *Using and Customizing the Window Manager* (Order No. AA-GT89A-TN) introduces the new user to the ULTRIX workstation environment. The manual describes how to use the window system and how to change the environment to suit the user's needs.
- *ULTRIX-32w QDSS/VCB02 Driver Reference* (Order No. AA-GT90A-TN) describes the ULTRIX kernel services that support the QDSS and other VAXstation II/GPX system hardware. The manual outlines device driver support of the VAXstation hardware and specifies the various driver services.
- *ULTRIX-32w QDSS Interface Library Programming* (Order No. AA-GT91A-TN) describes the optional ULTRIX C language library routines and macros that allow direct access and control of the QDSS/VCB02 graphics subsystem. The guide is intended for software engineers who are writing applications and need the performance afforded by direct access to the QDSS hardware.
- *ULTRIX-32w Xlib Programming Reference* (Order No. AA-GT92A-TN) describes the architecture, nomenclature, and C language interface of the ULTRIX application or window server and the terminal emulators. This provides a complete reference to the X window server C library, which supplies program control over text, graphics, window, and client applications.
- *ULTRIX-32w GKS/0b Programming* (Order No. AA-GT93A-TN) describes the operating system implementation of VAX GKS/0b. The guide discusses the program environment and the workstation specifics for QDSS, LN01, and X server. The guide also provides a reference to the C and FORTRAN (F77) GKS calls.

- *ULTRIX-32w Services Reference* (Order No. AA-GT94A-TN) includes descriptions of important programs and subsystems. This section can either be used separately, or individual pages can be inserted in the user's operating system Programmer's Manual.
- *C Language X Interface* (Order No. AA-HF10A-TN) describes the X window system software. Two contributors to the X window software wrote the paper.
- *ULTRIX-32m Master Index* (Order No. AA-CN36C-TE) allows fast access to information in the ULTRIX-32m documentation set. Individual indexes are included in each book.

MicroVMS Software

- *MicroVMS Release Notes (Latest Version)* contains last-minute information about MicroVMS. You may order the entire MicroVMS documentation set as a unit (Order No. 00-QZ001-GZ-4.4).
- *MicroVMS User's Primer* (Order No. AA-Z210C-TE) introduces the MicroVMS operating system to novice users.
- *MicroVMS User's Manual* (Order No. AA-Z209B-TE) describes the operation of the MicroVMS operating system.
- *MicroVMS User's Pocket Reference* (Order No. AA-Z211C-TE) summarizes the DIGITAL Command Language (DCL), EDT editor, DIGITAL Standard Runoff (DSR), and MAIL commands.
- *MicroVMS FORTRAN Programmer's Primer* (Order No. AA-Z213A-TE) contains concepts of program development using FORTRAN in the MicroVMS environment.
- *MicroVMS FORTRAN Programmer's Manual* (Order No. AA-Z212B-TE) contains guidelines for using VAX FORTRAN with MicroVMS tools, such as run-time library routines, system services, the debugger, and relevant utilities. The manual presents a task-oriented approach to programming with FORTRAN on a MicroVMS system. Specifications for VAX FORTRAN statements are included in an appendix.
- *MicroVMS Programming Support Manual* (Order No. AA-DC87B-TE) contains the specifications for the following MicroVMS programming support tools: the run-time library routines, system services, terminal and mailbox I/O function codes, debugger, linker, file definition language, message utility, command definition utility, and condition codes.

- *MicroVMS Programming Pocket Reference* (Order No. AA-Z214B-TE) contains syntax specifications for the following programming tools: run-time library routines, system services, debugger commands, and relevant DCL commands. The pocket reference also includes a summary for dot notation.
- *MicroVMS Workstation User's Guide* (Order No. AA-EZ24C-TN) describes the installation and use of the MicroVMS workstation software. You may order the entire MicroVMS workstation documentation set as a unit (Order No. 00-Q4A96-GZ-3.0).
- *MicroVMS Workstation Graphics Programming Guide* (Order No. AL-GL10B-TN) provides a tutorial and a reference to the MicroVMS workstation graphics programming interface.
- *MicroVMS Workstation Video Device Driver Manual* (Order No. AA-DY65D-TE) contains information about device drivers for programmers. The section on the VCB02 (QDSS) applies to the VAXstation II/GPX.

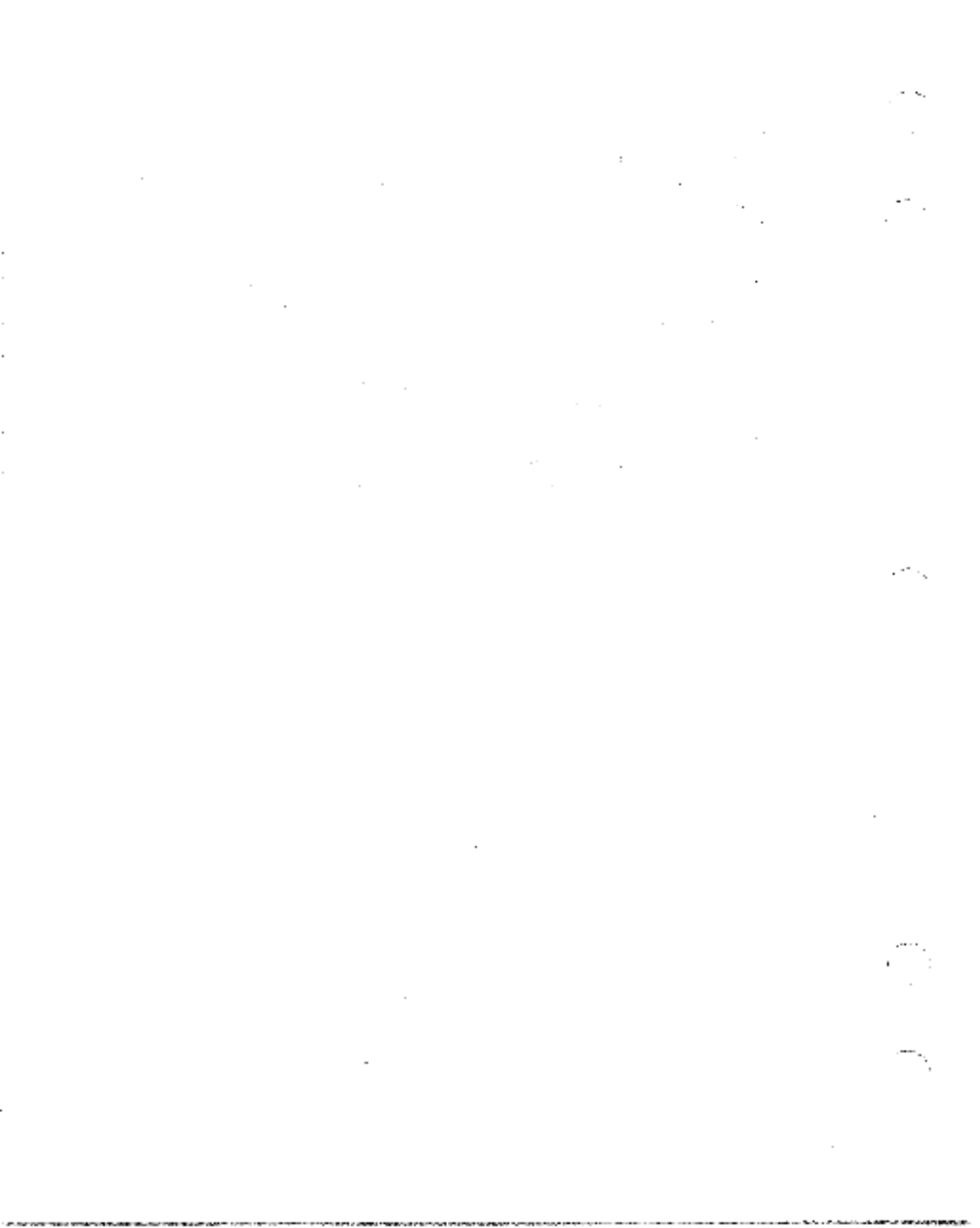

Glossary

application program

A program designed to perform a task, such as monitoring a manufacturing process.

ASCII

American Standard Code for Information Interchange. A set of 8-bit binary numbers representing the alphabet, punctuation, numerals, and other special symbols used in text representation and communications protocol.

asynchronous multiplexer

A device that provides asynchronous communication and brings together several low-speed communications channels. The device controls and alternates the transmission of signals with start and stop signals, so that more than one signal can be transmitted over a single communications line.

backplane

A connector block that connects modules through a bus and provides physical support of those modules.

back-up copy

A copy of data stored on your disk. The duplicate copy is stored on either RX50 diskettes or TK50 magnetic tape cartridges.

back-up process

The process of making copies of the data stored on your disk so that you can recover that data after an accidental loss. You make back-up copies on RX50 diskettes or TK50 magnetic tape cartridges.

baud rate

The speed at which signals are serially transmitted along a communications line. One baud equals one bit/second.

bezel

A cover used to hold and position the edges of a device.

binary

A number system that uses 2 digits: 0 and 1. They are represented in system circuitry by two voltage levels, and the system programs are executed in binary form.

bit

A binary digit; the smallest unit of information in a binary system of notation, designated as a 0 or a 1.

bitmap

The type of graphics supported by the VAXstation II/GPX. With bitmap graphics, the workstation software can individually access each dot (pixel) on the video screen.

boot

See *bootstrap*.

bootable medium

A fixed disk, diskette, or magnetic tape cartridge containing software (such as an operating system), that a bootstrap program can load into the system memory and begin program execution.

bootstrap

1. A program that you start when you turn on the system. The bootstrap loads software contained on fixed disk, diskette, or magnetic tape cartridge into memory; the system stops executing the bootstrap and starts executing the software in memory. The software usually loads an operating system or other software into memory so that the system can start processing.
2. To use a bootstrap program.

bus

A printed circuit module that is part of the backplane. The bus permits the sharing of signals among the system modules.

byte

A group of eight binary digits (bits). A byte is one-quarter of the size of a system word.

Central Processing Unit (CPU)

The part of the system that controls the interpretation and execution of instructions. In the VAXstation II/GPX system, CPU functions are contained on one MicroVAX II CPU chip.

command

An order you can give to the system, often through a terminal keyboard.

communications line

A cable along which electrical signals are transmitted. Devices or systems that are connected by a communications line can share information and resources.

computer system

A combination of system hardware, software, and external devices that performs operations or tasks.

console mode

The stage at which a device can communicate directly with the CPU. For the VAXstation II/GPX, console mode is activated by pressing the halt pushbutton when the **Halt Enable/Disable** switch is enabled (up) and is indicated by the arrow prompt (>>>) on the system monitor.

controller

A system component, usually a printed circuit module, that regulates the operation of one or more peripheral devices. Controllers are often called interface units.

control panel

The panel on the front of the system cabinet that contains control switches and indicator lights.

CPU

Abbreviation for Central Processing Unit. See *Central Processing Unit*.

CRT (Cathode Ray Tube)

A vacuum tube that generates and guides electrons onto a fluorescent screen to produce characters or graphics. A term often used to refer to a monitor.

data

A representation of facts, concepts, or instructions in a formalized manner suitable for communication, interpretation, or processing by humans or by automatic means.

data transmission

The movement of data in the form of electrical signals along a communications line.

debug

To detect, locate, and correct errors (bugs) in system hardware or software.

DECnet

DIGITAL communication network.

device

The general name for any unit connected to the system that is capable of receiving, storing, or transmitting data. See *input device*, *output device*, *Input/Output device*, and *controller*.

device name

The name by which a device or controller is identified in the system. You use that name to refer to that device when you are communicating with the system.

diagnostic medium

Diskette or tape that contains diagnostics. See *diagnostics*.

diagnostics

A program that detects and identifies abnormal system hardware operation. The VAXstation II/GPX "Maintenance System" software contains several diagnostic programs.

disk

A flat circular plate with a coating on which data is magnetically stored in concentric circles (tracks). The VAXstation II/GPX contains at least one fixed disk, either the RD53 or RD54 disk drive subsystems, or both.

disk drive

A device that holds a fixed disk. The drive contains mechanical components that spin the disk and move the read/write heads that store and read information on the surface of the disk. The VAXstation II/GPX disk drive can read and write on the RD53 and RD54 fixed disks.

disk drive subsystem

A free-standing disk drive that provides additional storage for the system. The RD53 and RD54 are disk drive subsystems that can be added to the VAXstation II/GPX.

diskette

A flexible, floppy disk contained in a square paper envelope. The VAXstation II/GPX uses the RX50 13.13-centimeter (5.25-inch) diskettes.

diskette drive

A disk drive that only reads or writes on removable diskettes. The VAXstation II/GPX diskette drive uses RX50 diskettes.

dot matrix

A method of generating characters for printing that uses dots to produce readable characters.

down-line load

To send a copy of a system image or other file over a line to the memory of a target node.

error message

A message displayed by the system to indicate a mistake or malfunction.

file

A collection of related information treated by the system as a single item.

formatted data

A pattern of data that conforms to a predetermined structure dictated by the system software.

GKS

Graphics Kernel System. GKS acts as one of the graphics interface for the VAXstation II/GPX.

GPX

Graphics Processing Extension.

hard-copy terminal

A terminal that displays information on paper. Compare to *video terminal*.

hardware

The physical components—mechanical and electrical—that make up a system. Compare to *software*.

head

The part of a fixed disk drive, diskette drive, or tape drive that reads, records, and erases data. Also called read/write head.

host

The primary or controlling computer in a multiple computer network.

input device

A piece of equipment that is used to transfer data to the system. For example, a keyboard is an input device.

Input/Output (I/O) device

A piece of equipment that accepts data for transmission to (input) and from (output) the system. For example, a terminal.

interactive

The method of communicating with the system. You type a command at the keyboard. The system executes the command and responds with a prompt character for another command.

interface

A device or piece of software that allows the components of the system to communicate.

I/O

Abbreviation for Input/Output. See *Input/Output (I/O) device*.

K

The symbol that means 2 to the 10th power (or 1024 in decimal notation).

kilobyte

1000 bytes.

LED

Light-Emitting Diode. LEDs are used as indicators on the control panel. A segmented LED display on the CPU distribution panel insert on the back of the VAXstation II/GPX cabinet displays the characters F-A and 8-D during the power-on sequence to indicate CPU status and normal/abnormal operation.

load

1. To move software (usually from a peripheral device) to memory.
2. To physically place a disk on a disk drive or a tape on a tape drive.

Local Area Network (LAN)

A data communications system designed for a small geographic area that offers high-speed communications channels optimized for connecting information processing equipment. For example, Ethernet.

M

The symbol for 1024 squared (1,048,576 in decimal notation).

magnetic tape

A strip of plastic coated with magnetic oxide and used for storing data. Often called magtape.

megabyte

1,000,000 bytes.

memory

The area of the system that holds the instructions and data that temporarily store information.

memory module

A logic circuit module that contains additional memory for the system. Two memory modules with 1, 2, or 4 megabytes of memory can be added to the VAXstation II/GPX.

menu

A displayed list of options that you can select to run.

MicroVAX Workstation

Any workstation based on the 32-bit MicroVAX CPU. The workstations include the MicroVAX and the VAXstation systems.

MicroVMS

A micro version of the VAX/VMS operating system for MicroVAX-based systems. MicroVMS enables installation of only those parts of the VMS operating system you require, but will allow access to all VMS operations.

MicroVMS Workstation Software

Window management software for a MicroVAX-based system. The system must run MicroVMS as the operating system. Workstation software allows you to control and view several programs on one screen. You specify the window with which to interact by using a pointing device.

module

A printed circuit board. The module contains chips, electrical components, and electrically conductive pathways between components. A module stores data or memory, or controls the functions of a device.

mouse

A relative-positioning input device that is rolled across the desktop to move the cursor on the monitor screen, and is used to select menu options and draw graphics. The mouse is palm-sized, contains three pushbuttons (function keys), and a ball bearing. The mouse is a pointing device for the VAXstation II/GPX.

network

A group of individual computer systems that are connected by communications lines to share information and resources.

node

An individual information-processing unit, such as a computer, workstation, or peripheral device, that is connected to a network.

off-line

Pertaining to equipment, devices, and events that are not controlled by the system.

on-line

Pertaining to equipment, devices, and events that communicate with the system.

operating system

A collection of system programs that control the operation of the system and perform such tasks as assigning memory to programs and data, processing requests, scheduling jobs, and controlling the operation of input and output devices.

output device

A device that extracts data from the system. A printer is an example of an output device.

peripheral device

A device that provides the CPU with additional memory storage or communication capability. Examples are disk and diskette drives, video terminals, and printers.

plane

Measures 1K x 1K x 2K and holds a total of 256K memory.

pointing device

A terminal input device that allows you to make a selection from a menu or to draw graphics. See *mouse*, *puck*, *stylus*, and *tablet*.

power-up sequence (power up)

A series of ordered events that occur when you supply power by turning on the system.

printer

A peripheral device that provides paper copies of information stored on the system.

program

The sequence of instructions the system needs to perform a task. See *software*.

prompt

Words or characters that the system displays to indicate that it is waiting for you to type a command.

puck

A flat, rectangular, 4-pushbutton pointing device included with the tablet, which moves the cursor on the monitor screen, draws graphics, and makes selections from the menu. See also *tablet*.

RAM

Abbreviation for Random-Access Memory. See *Random-Access Memory (RAM)*.

Random-Access Memory (RAM)

Memory that can be both read and written into during normal operations. The type of memory the system uses to store the instructions of programs currently being run.

rester

A linear measurement unit for graphics characters.

Read-Only Memory (ROM)

A memory whose contents cannot be modified. The system can use the data contained in a ROM but cannot change it.

reboot

To restart the system. Pressing the Restart pushbutton on the control panel reboots the VAXstation II/GPX system, if the **Halt Enable/Disable** switch on the back of the VAXstation II/GPX cabinet is in the up (enable) position.

ROM

Abbreviation for Read-Only Memory. See *Read-Only Memory (ROM)*.

run

1. A single continuous execution of a program.
2. To execute a program.

software

Programs executed by the system to perform a chosen or required function. Compare to *hardware*.

storage medium

Any device capable of recording information, for example, a diskette.

store

To enter data into a storage device, such as a disk, or into memory.

stylus

A stencil-shaped pointing device included with the tablet, which moves the cursor on the monitor screen, draws graphics, and makes selections from the menu. See also *tablet*.

synchronous line controller

A device that provides high-speed synchronous communication for distributed networks. Three varieties of the DMV11 are optional synchronous line controllers for the VAXstation II/GPX.

system

A combination of system hardware, software, and peripheral devices that performs specific processing operations.

system image

The image that is read into memory from disk when the system is started up (booted).

system management tasks

Tasks performed by the operating system and used to control the operation of the system.

tablet

An absolute-positioning input device comprised of a flat-surfaced digitizing tablet, a puck, and a stylus. The tablet is a drawing surface used with the puck or stylus as a pointing device to move the cursor on the monitor screen, and to draw graphics and make selections from the menu. The tablet may be used with the VAXstation II/GPX.

tape drive

A device that contains mechanical components and holds, trns, reads, and writes on magnetic tape. The VAXstation II/GPX uses the TK50 tape drive.

Tektronix® 4014

A storage-tube display terminal sold by Tektronix, Inc.

terminal

An Input/Output device that allows you to communicate with the system. Terminals are divided into two categories: video and hard-copy.

32-bit length

The length of the internal data path of the CPU. This length provides more concentrated data, allows more data types, and enables more data to be transferred at one time than a 16-bit internal data path.

ULTRIX-32m

ULTRIX-32m is an interactive, time-sharing operating system derived from UNIX® and enhanced by DIGITAL to work with MicroVAX hardware and software.

ULTRIX-32w

The window management software for a MicroVAX-based system. The system must run ULTRIX-32m as the operating system. Workstation software allows you to control and view several programs on one screen. You specify the window with which to interact by using a pointing device.

VC802

A video subsystem that provides 1024 x 864 pixel resolution on a 47.5-centimeter (19-inch) color monitor. The 4-plane subsystem simultaneously displays 16 colors, while the 8-plane subsystem simultaneously displays 256 colors.

video terminal

A terminal that displays information on the screen of a cathode ray tube (CRT). Compare to *hard-copy terminal*.

VLSI

Very Large Scale Integration of integrated circuit chips. A large number of chips can fit on a printed circuit module; therefore fewer modules are needed, and the system can be smaller.

VT100 terminal

An American National Standards Institute (ANSI)-compatible terminal offered by DIGITAL.

Winchester disk

A hard disk permanently sealed in a drive unit to prevent contaminants from affecting the read/write head. The sealed Head/Disk Assembly (HDA) helps to increase drive reliability and ensure data integrity.

window

An area on your monitor screen in which you can start, run, and view a separate process. Windowing is supported by both MicroVMS and ULTRIX workstation software.

word

The largest number of bits (32) that the VAXstation II/GPX can handle in an operation. The VAXstation II/GPX can also handle longwords (that is, two words or 64 bits).

write-protect

To protect a disk, diskette, or other storage medium from the addition, revision, or deletion of information.

write-protect notch

The small notch on the side of an RX50 diskette that you can cover with an adhesive-backed foil label or tab to prevent loss of data by accidental overwriting.

writes-protect switch

The switch that you slide down on a TK50 tape cartridge to prevent loss of data by accidental overwriting.

A

- Accessories kit
 - components, 1-2
- Asynchronous multiplexers
 - description, 4-23, 4-24
 - installation, 4-23, 4-24

B

- Barrel connector
 - description of, 4-20
 - determining need for, 4-19
- BNE3x cable
 - lengths, 4-19
 - types, 4-18

C

- Color monitor
 - specifications, A-2
- Communication modules
 - description, 4-18
- Connector
 - determining need for, 4-19
- Connectors
 - list of, 4-20
- Consolidation carton
 - components, 1-2
- Controller
 - storage devices, 4-16

D

- DEUNI
 - description, 4-18
 - installation, 2-20
- DEQNA
 - description, 4-18

DEQNA (cont'd.)

- installation, 4-18
- DESTA
 - determining need for, 4-19
 - See DIGITAL ThinWire Ethernet Station Adapter, 4-21
- DF112 modem
 - description, 4-22
 - option, 4-22
- DF124 modem
 - description, 4-22
 - option, 4-22
- DF224 modem
 - description, 4-22
 - option, 4-22
- DHV1i
 - description, 4-24
 - installation, 4-24
- Diagnostics
 - configuration and devices display, 5-18
 - exiting diagnostics, 5-18
 - field service menu, 5-18
 - initial display, 3-10
 - initial testing, 2-25
 - introductory display, 2-30
 - maintenance system, 5-17
 - maintenance system main menu, 5-17
 - mode switch, 2-32
 - power-up messages, 5-1
 - RX50 diskette insertion, 2-28
 - setting date and time, 2-30
 - system utilities menu, 5-18
 - testing with the RX50 diskette, 2-27
 - testing with the TK50, 2-25

Diagnostics (cont'd.)

- testing with the TK50, 2-25
- test screen, 2-33
- TK50 tape, 2-23
- TK50 tape insertion, 2-27
- DIGITAL ThinWire Ethernet Multiport Repeater, 4-20
- DIGITAL ThinWire Ethernet Station Adapter, 4-21
 - features of, 4-21
 - ports of, 4-21
- DIGITAL ThinWire Ethernet Station Adapter, definition, 4-21
- Disk drive, fixed
 - description, 3-13
 - location, 3-13
- Diskette
 - back-up, 3-24
 - description, 3-19
 - drive, 3-20
 - handling, 3-23
 - insertion, 3-22
 - labeled, 3-21
 - overwrite protection, 3-23
 - storage, 3-23
- Diskette drive, RX50
 - Specifications, A-8
- DMV11
 - description, 4-24
 - installation, 4-26
- Documentation
 - hardware, 1-2, B-1
 - MicroVMS, B-4
 - ULTRIX, B-2
- DPV11
 - description, 4-26
 - Installation, 4-26
- DZQ11
 - description, 4-23
 - installation, 4-23

E

- Environment
 - system, 1-6

F

- Fixed disk drive, RD53
 - specifications, A-7
- Fixed disk drive, RD54
 - specifications, A-8
- Fonts
 - LA210, 4-6
 - LCC01, 4-9
 - LN03, 4-2
- Front control panel
 - controls and indicators, 3-1
 - DC OK indicator, 3-5
 - fixed disk pushbuttons, 3-8
 - halt pushbutton, 3-6
 - power switch, 3-4
 - Restart/Run pushbutton, 3-5
- Fuse
 - replacing, 5-10

H

- H4000
 - installation, 4-18
- Hardware support kit
 - components, 1-2

I

- Input devices
 - mouse, 4-14
 - tablet, 4-13

K

- Keyboard
 - cable assembly connection, 2-7
 - installation, 2-7
- KMV11
 - description, 4-27
 - installation, 4-27

L

- LA210
 - description, 4-6
 - installation, 4-6, 4-12

LA210 (cont'd.)

picture of, 4-6

LA50

description, 4-8

installation, 4-9, 4-12

picture of, 4-9

LA75

installation, 4-12

LA75 printer

description, 4-7

option, 4-7

Labels

placement of, 2-10

LCG01

description, 4-9

installation, 4-10

LCP01

installation, 4-12

LN03

description, 4-2

installation, 4-3, 4-12

picture of, 4-3

LN03 PLUS

installation, 4-12

LN03 PLUS printer

description, 4-3

option, 4-3

LPS40 printer

description, 4-4

option, 4-4

LVP16

description, 4-10

installation, 4-10, 4-12

M

M7168

description, 4-15

installation, 4-15

M7169

description, 4-15

Maintenance System

options, 5-17

MDM, 5-17

Memory module

description, 4-14

installation, 4-14

types, 4-14

MicroVAX Diagnostic Monitor

main menu, 5-17

Modems

list, 4-22

Monitor

site-preparation, 1-4

Monitor, color

cable assembly connection, 2-5

front and side controls, 3-11

fuse, 5-10

carrier, 5-11

location, 5-11

keyboard connection, 2-7

placement, 2-3

power cord, 2-14, 2-17

power switch, 2-2

power up, 2-24

rear controls and connectors, 3-12

specifications, 1-5, A-2

system unit connection, 2-13

troubleshooting procedures, 5-8

Mouse, 4-14

cover plate, 5-13

installation, 2-8

maintenance, 5-13

schedule, 5-13

specifications, A-4

use of, xii

MS630

description, 4-14

installation, 4-14

O

Option

DMV11 synchronous line

controller, 4-24

Options

DEQNA communications module,

4-18

Options (cont'd.)

- DHV11 asynchronous multiplexer, 4-24
- DPV11 synchronous line controller, 4-26
- DZQ11 asynchronous multiplexer, 4-23
- KMV11 programmable controller, 4-27
- LA210, 4-6
- LA50, 4-8
- LA75 printer, 4-7
- LCC01, 4-9
- list of, 4-1
- LN03, 4-2
- LN03 PLUS printer, 4-3
- LVP16, 4-10
- maintenance system main menu, 3-17
- memory modules, 4-14
- modems, 4-22
- mouse, 4-14
- MS630, 4-14
- 4-plane module, 4-15
- 8-planes, 4-15
- printers, 4-2
- PrintServer 40 (LPS40) printer, 4-4
- RD53 fixed disk drive, 4-16
- RD54 fixed disk drive, 4-16
- RX50 Dual Diskette Drive, 4-17
- tablet, 4-13
- TK50 Tape Drive, 4-17

P

- 4-plane Module
 - description, 4-15
 - installation, 4-15
- 8-Planes
 - description, 4-15
- Plotter
 - LVP16, 4-10
- Pointing Device
 - troubleshooting, 5-10

- Pointing device
 - installation, 2-6
- Power requirements
 - system, 1-5
- Power up
 - messages, 3-1
 - troubleshooting procedures, 3-3
- Printers
 - connection to VAXstation II/GPX, 4-11
 - LA210, 4-6
 - LA50, 4-8
 - LA75, 4-7
 - LCC01, 4-9
 - LN03, 4-2
 - LN03 PLUS, 4-3
 - system unit connection, 4-12
 - types, 4-2
- PrintServer 40 (LPS40)
 - description, 4-4
 - option, 4-4

R

- RD53 fixed disk drive
 - description, 4-16
 - specifications, A-7
- RD54 fixed disk drive
 - description, 4-16
 - specifications, A-8
- Read and Write Errors
 - troubleshooting procedures, 5-6
- RQDX3, 4-16
- RQDX3 controller, 4-16
- RX50, 4-16
 - description, 4-17
 - installation, 4-17
 - specifications, A-8

S

- Service
 - procedures, 6-1
- Shipment components
 - listing, 1-1

- Site-preparation
 - environment, 1-6
 - power requirements, 1-3
 - space planning, 1-3
- Software carton
 - components, 1-2
- Storage device option package, 4-16
- Synchronous line controllers
 - description, 4-26
- Synchronous line controllers
 - description, 4-24
 - installation, 4-26
- Synchronous lines controllers
 - installation, 4-26
- System
 - connecting the transceiver cable, 2-19
- System halts
 - troubleshooting, 5-6
- System unit
 - adjusting baud rate, 2-12
 - connecting video cable, 2-13
 - control panel, 2-10, 3-1
 - cover opening, 2-11
 - CPU distribution panel, 2-12
 - diskette drive, 3-20
 - installation, 2-10
 - labels, 2-10
 - physical specifications, 1-4
 - power cord, 2-14, 2-18
 - power on/off, 2-16
 - power requirements, A-1
 - setting controls, 2-12
 - site-preparation, 1-3
 - troubleshooting procedures, 5-3
 - voltage setting, 2-15

T

Tablet

- description, 4-13
- installation, 2-8, 4-13
- specifications, 4-13
- specifications, A-5
- use of, xii

Tape

- back-up, 3-24
 - description, 3-13
 - drive, 4-17, 5-7
 - drive specifications, A-9
 - handling, 3-19
 - insertion, 3-14
 - overwrite protection, 3-18
 - storage, 3-19
 - TK50, A-9
- ### T connector
- description of, 4-20
 - determining need for, 4-19
- ### Terminator
- description of, 4-20
 - determining need for, 4-20
- ### ThinWire Ethernet
- connectors, 4-20
 - termination, 4-20
- ### TK50, 4-16
- troubleshooting, 5-7
- ### Transceiver
- definition, 4-21
- ### Transceiver cable, 4-18, 4-19
- ### Troubleshooting
- basic, 5-2
 - color monitor, 5-8
 - diskette drive, 5-5
 - maintenance system, 5-17
 - power up, 5-1, 5-3
 - procedure, 5-1
 - read and write errors, 5-6
 - system halts, 5-6
 - system unit, 5-3
 - TK50 tape drive, 5-7
- ### Two-user system, 4-15

V

VAXstation II/GPX

- carton components, 1-2
- described, xi
- environmental requirements, 1-6, A-2
- network, 2-19

VAXstation II/GPX (cont'd.)

- options, xi, 4-1
- power requirements, A-1
- printer connection, 4-11
- service, 6-1
- shipment components, 1-2
- site-preparation, 1-3
- software installation, 2-35
- testing, 2-24
- troubleshooting, 5-1
- turning off, 3-10
- turning on, 3-8

VCB02

- video subsystem, 4-15

Voltage

- system unit setting, 2-35

W

Windows

- described, xii

HOW TO ORDER
ADDITIONAL DOCUMENTATION

From	Call	Write
Alaska, Hawaii, or New Hampshire	603-884-6660	Digital Equipment Corporation P.O. Box CS2008 Nashua, NH 03061
Rest of U.S.A. and Puerto Rico*	800-258-1710	
* Prepaid orders from Puerto Rico must be placed with DIGITAL's local subsidiary (809-754-7575)		
Canada	800-267-6219 (for software documentation) 613-592-5111 (for hardware documentation)	Digital Equipment of Canada Ltd. 100 Herzberg Road Kanata, Ontario, Canada K2K 2A6 Attn: Direct Order desk
Internal orders (for software documentation)	—	Software Distribution Center (SDC) Digital Equipment Corporation Westminster, MA 01473
Internal orders (for hardware documentation)	617-234-4323	Publishing & Circulation Serv. (P&CS) NR03-1/W3 Digital Equipment Corporation Northboro, MA 01532

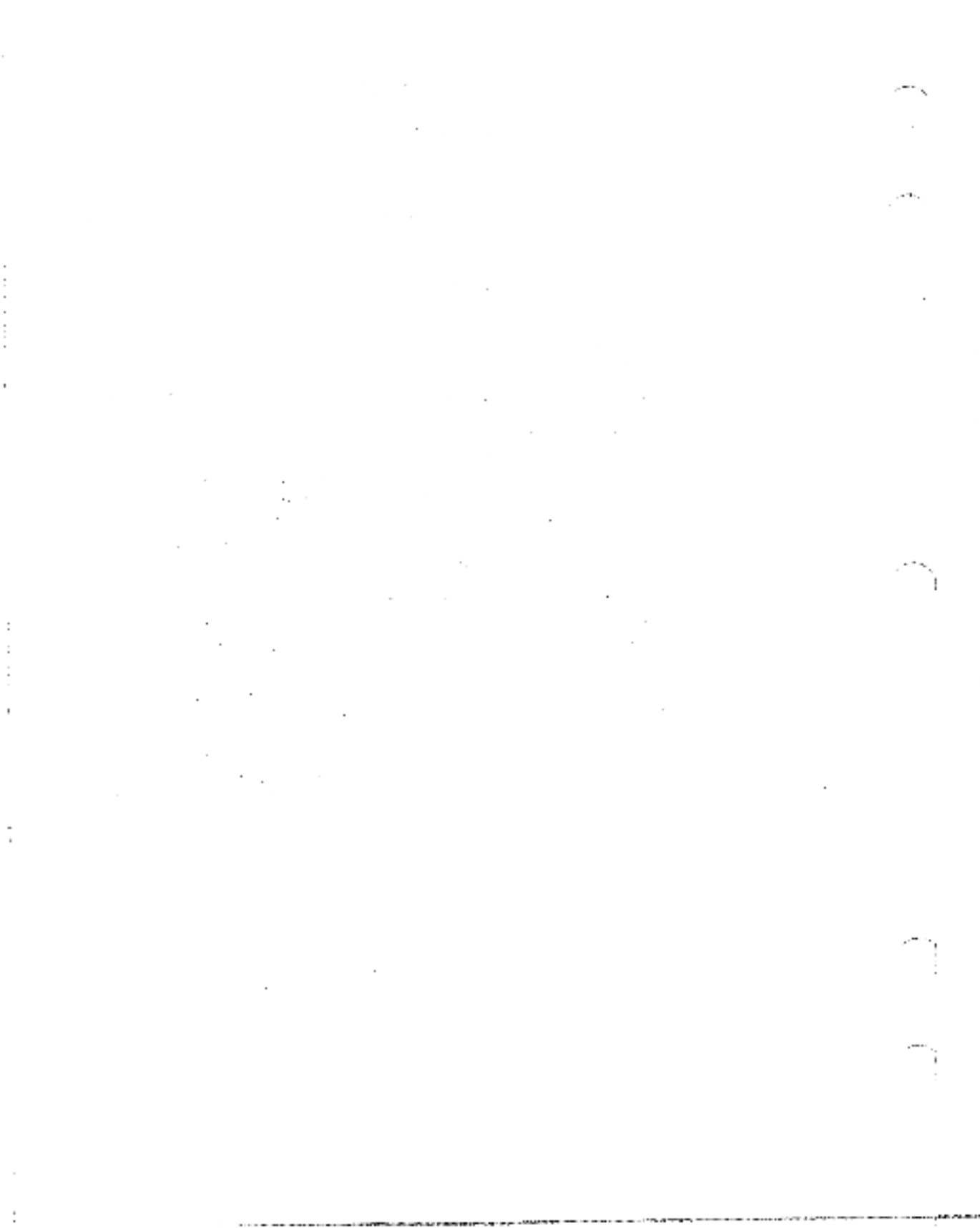

READER'S COMMENTS

Note: This form is for document comments only.
DIGITAL will use comments submitted on this
form at the company's discretion.

Did you find this manual understandable, usable, and well organized? Please
make suggestions for improvement.

Did you find errors in this manual? If so, specify the error and the page
number.

Please indicate the type of user/reader that you most nearly represent:

- Administrative Support
- Computer Operator
- Educator/Trainer
- Programmer/Analyst
- Sales
- Scientist/Engineer
- Software Support
- System Manager
- Other (please specify) _____

Name _____ Date _____

Organization _____

Street _____

City _____ State _____ Zip Code _____
or Country

Do Not Tear — Fold Here and Turn

digital



NO POSTAGE
NECESSARY
IF MAILED
IN THE
UNITED STATES

BUSINESS REPLY MAIL

FIRST CLASS PERMIT NO. 33 MAYNARD MASS.

POSTAGE WILL BE PAID BY ADDRESSEE

DIGITAL EQUIPMENT CORPORATION
CORPORATE USER PUBLICATIONS
MLO5-S/E45
146 MAIN STREET
MAYNARD, MA 01754-2571



Do Not Tear — Fold Here

Along Dotted Line