

PDP-10 INSTALLATION MANUAL

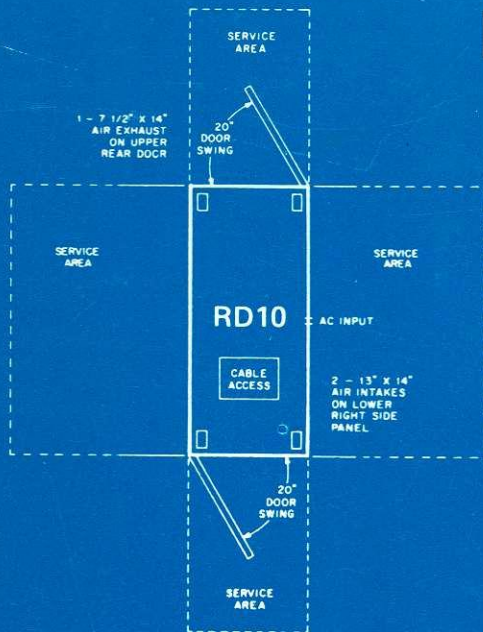

CABINET FRONT



FRONT OF CABINET



CABINET FRONT

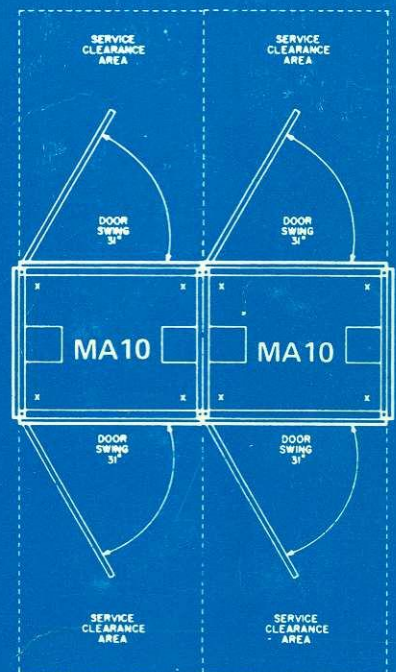

CABINET FRONT

CABINET FRONT

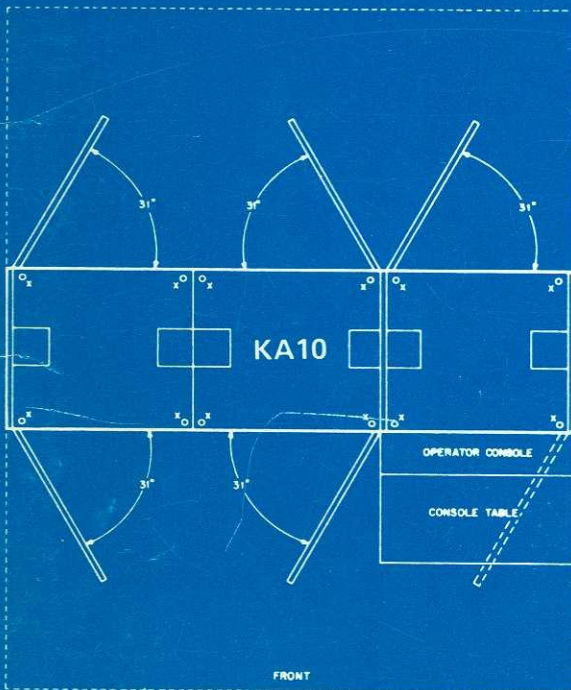

FRONT

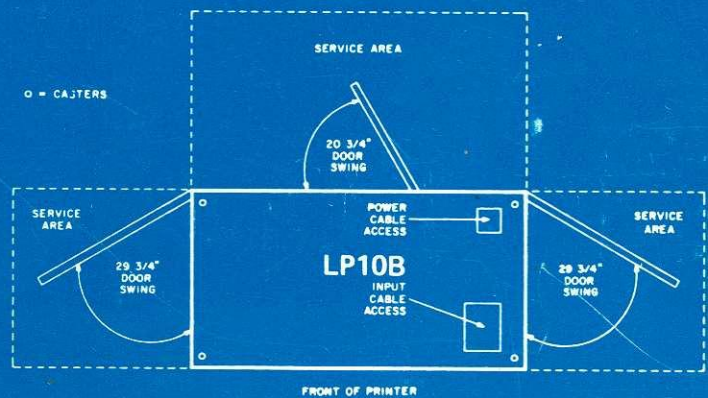

FRONT OF PRINTER

INTRODUCTION

This manual presents information needed in order to properly plan the physical installation of a PDP-10 system.

It contains such information as floor planning guides, cutouts, graphs, electrical requirements, air conditioning needs, flooring types recommended, layout of equipment, and in short, everything needed to plan an efficient, workable installation.

System requirements are subject to modification by engineering developments from time to time. This manual will be kept up-to-date as such modifications occur.

SCHEDULE OF SITE PREPARATION PRIOR TO SYSTEM DELIVERY.

The following is a suggested schedule of site preparation and should be adhered to as closely as possible:

Six to ten months before system delivery:

1. Read and review this manual.
2. Determine the location of the system and make a layout (using the layout kit which is part of this manual) of the installation.
3. Determine requirements for power, air conditioning, floor construction, placement of power receptacles, etc.
4. Check door sizes, elevators or other restrictions which may create installation problems.
5. Check local delivery of power and air conditioning equipment to make sure they will be available before system delivery.

Four months before system delivery:

1. Final installation layout should be resolved between customer and Digital so that all cabling may be ordered. This is very important, as no changes should be made in the layout which will change cable lengths.

One month before system delivery:

1. Local Digital sales representatives will make a visit to determine specific requirements for moving system components from the truck or customer loading platform to the installation site.

One week before system delivery:

1. All air conditioning equipment, electrical facilities, lighting, floor ramps, painting, etc., should be installed, completed, and ready for operation. Air conditioning should be tested and at operating temperature before system is delivered.

BUILDING REQUIREMENTS

Consideration should be given the following points when selecting an installation site:

1. Proper power requirement availability and location at site.
2. Proper air conditioning equipment housing.
3. Efficient work-flow pattern to other work areas.
4. Floor loading capacity.
5. Proper fire and safety requirements.

SYSTEM COMPONENT LAYOUT SUGGESTIONS

Thought should be given to space requirements for future system expansion. Space should be provided for such things as tape storage, printer forms stands, spare parts storage, storage cabinets, card files, work tables, desks, and DECtape files.

Site space, number of components, service clearances between machines, work space, aisles, storage cabinets, etc., and maximum cable lengths are major factors in determining optimum system layout. The final layout must be jointly approved by both customer and Digital Equipment Corporation. To help make a layout, a layout kit containing floor plans of all components is supplied. These plans, scaled at $\frac{3}{8}$ inch to one foot, contain all necessary information to accurately design a workable installation area. They show load points, casters, service clearances, door-swing, cooling air ducts, and cable access openings.

In laying out a system, these points should also be taken into consideration:

1. Ease of visual observation of control units and input/output devices by operating personnel.
2. Light-levels in areas where display and read-out devices reside. Too high a level should be avoided.

3. Remote tele-processing equipment requirements should be reviewed with local sources. Lines should be installed before system installation.

FLOOR CONSTRUCTION

Weights of components are listed so that total weight of a system can be reviewed in selecting the correct site.

A raised floor is recommended. It will provide the following advantages:

1. A minimum cost for changes in future layout.
2. Protection for cables and power sources.
3. Safety for operating personnel, no wires to trip on.
4. Space for air ducts, or it can act as a plenum if desired.
5. Overall site appearance.

ACOUSTICAL SUGGESTIONS

Some degree of acoustical treatment is desirable in most installations. How much acoustic damping needed is dependent on variables such as ceiling height, room size, type and number of components, etc. Principal noise sources are the mechanical devices such as line printers, tape drives, card readers, and cooling blowers.

It is suggested that the floor be constructed of materials which will damp noise vibration to other areas. Walls should be structured with a dead-air space between two sound-retardant wall faces. Ceilings properly treated with acoustic dampeners or acoustic materials will provide the greatest reductions in noise-levels. Duct work is always a problem. Unless carefully acoustically treated, noise can be transmitted to other areas.

ENVIRONMENTAL REQUIREMENTS

Air Conditioning

Heat dissipation figures in BTU/hr. are given on the System Components Specification Summary Chart in this manual. To estimate air conditioning requirements, consult this chart and total your Systems' BTU/hr. output. Other factors to consider are the number of personnel; heat radiating from other areas through walls, ceilings and floors; sun exposure through windows, etc. A separate air conditioning system is normally required for a large computing installation.

Humidity and Temperature

PDP-10 system components are designed to operate within temperature and humidity ranges as specified. Individual peripheral devices may deviate from overall system specifications. Consult System Components Specification Summary Chart for these figures. Overall system *operating* requirements are:

Temperature:	60° to 95 °F
Relative Humidity:	20% to 80%
Max. Wet Bulb:	78°F

Note: Certain peripheral devices require 40% to 60% Relative Humidity.

Storage requirements are:

Temperature:	40° to 110 °F
Relative Humidity:	10% to 80%
	(No condensation!)
Max. Wet Bulb:	80°F

The ideal operating condition for a PDP-10 System is 70°F and 50% relative humidity.

When operating, room temperature should not exceed 95 °F. This is maximum. Relative humidity should not exceed 80%. This is maximum. (Unless system includes peripheral devices which require less rel. hum. range.)

If it should be necessary to increase relative humidity, one of the following procedures is advised:

1. A commercially available humidifier capable of raising and maintaining proper humidity percentage.
2. Steam cups
3. Steam grids or jets

It is recommended that temperature and humidity recording instruments be installed at the system site to continually monitor and record these conditions. Certain advantages are realized from such records:

1. The customer can easily determine if the required operating conditions are met on a constant basis, and that his air conditioning equipment is functioning properly.
2. If humidity requirements are exceeded, the customer can determine if a drying out period is needed to prevent card and tape damage and inefficient operation.

FIRE AND SAFETY SUGGESTIONS

When planning a computer installation, safety is an important factor. With this in mind, the selection of the site, construction, materials used, electrical system, and fire prevention equipment must be considered and planned carefully. The following points are listed to help reduce the damages of fire and eliminate safety hazards:

1. The installation should be built to be as fire-resistant as possible.
2. It should not be located above or adjacent to inflammable materials, gases, or where explosives are stored, manufactured, or processed.
3. The entire installation area should be water-tight to the degree that in case of flooding, high-wind-driven rain, or other exceptional water conditions, the computing system, tapes, etc. will not be subjected to water damage.

Fire prevention equipment recommended for the site are listed below. However, local codes or insurance requirements will probably dictate this equipment.

1. Carbon dioxide extinguishers of 15 lbs. or so should be immediately convenient to all site locations. They should be easily seen and reached. Regular inspection of the cylinders as to condition is mandatory.
2. Overhead sprinkler systems usually are required by insurance and/or local fire codes. It is recommended that a "pre-action" type sprinkler system or a system with high-temperature (175°F) heads be used, rather than a system which contains water at all times or has lower temperature rated heads.

One might consider the necessity for storage of magnetic tapes, paper tape, cards, punched forms, etc., within fire-resistant vaults or safes, or the requirements for storage of duplicate records, tapes, etc. at a remote site.

Electric Systems

Electrical service to the computer area should be protected by a main line breaker. The control should be readily accessible to operating personnel. A "power-on" light should be mounted in sight of operators.

It is recommended that a battery-operated light source which will automatically come on in case of power failure be mounted to provide emergency lighting.

Lightning surges can be countered by the installation of arrestors mounted on the secondary power source. Most effective suppression can be effected when the utility company installs protection on the primary source, or when the primary power is supplied from an overhead power service.

Waterproof power receptacles, and connectors should be used if they are located under false floors. Proper drainage planning will guard against an excess water condition.

Power Failure

In case of power failure, a PDP-10 system will shut down automatically, with no system damage. When two consecutive power line cycles are missed by PDP-10's power fail detector a "power failure" flag comes on and causes a program interrupt. During the next 10 milliseconds, valuable information can be stored via the program. After that period, a train of "power clear" pulses is generated, stopping all I/O processor operations.

General Precautions

To assure that the system site environment is constant, monitoring equipment or personnel is recommended during non-operating periods. All incoming services such as water, power, etc. should be regularly inspected. Pipes should be checked for excess condensation, leaks, or corrosion.

PDP-10 installation data

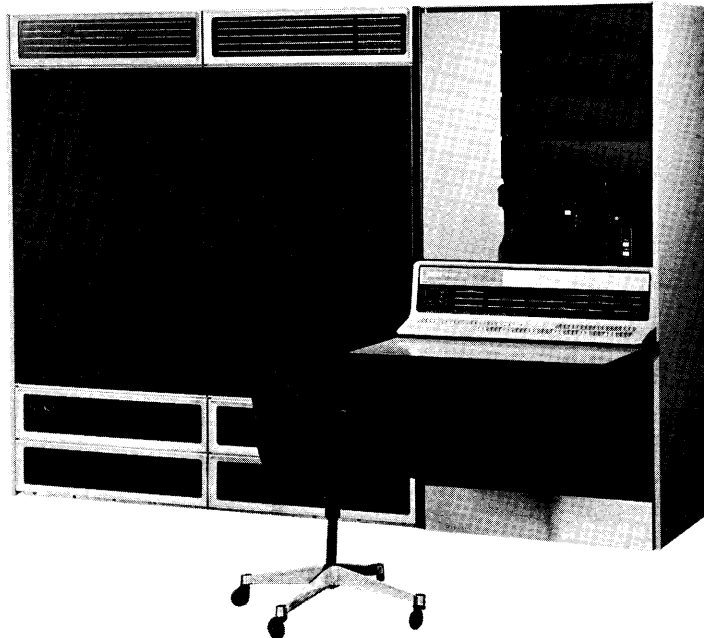

KA10 CENTRAL PROCESSOR

Description

The KA10 is the basic Arithmetic Processor for all PDP-10 Systems. Included with the basic processor are the following:

- 300 character per second (cps) photoelectric paper tape reader
- 50 cps paper tape punch
- 10 cps console teleprinter
- Operator console and table

Options that are located within the KA10 cabinets are: KE10 Extended Order Code, KT10 Memory Protection and Relocation, and KM10 Fast Registers.

KE10 KT10 KM10

KE10 Extended Order Code implements 40 additional hardware instructions; 35 are floating point, and 5 are byte manipulation instructions.

The KT10 Memory Protection and Relocation Option allows executive/user mode operation, permitting the executive routine to assign multiples of 1024-word blocks of storage to a user. The protection feature prevents the user from accessing storage assigned to other users.

The KM10 Fast Register Option consists of sixteen 36-bit integrated circuit registers that are used as accumulators, index registers, and/or as the first 16 locations in addressable memory.

Physical Specifications

Voltage (AC)	Current (A) Nominal @ 115V	Power Dissipation (W)	Heat Dissipation (Btu/hr)	Dimensions (inches)	Service Clearance (inches)	Weight (lbs)	Operating Temperature (min-max F)	Storage Temperature (min-max F)	Humidity (Rel) (min-max)	Maximum Wet Bulb	Maximum Cable Length
See Note 1 Note 2	20/ Phase	4300	14,700	Height 69 Width 98 Depth 34-1/2	Front 42 Rear 42	1920	60° to 95°	40° to 110°	20% to 80%	78°F	No Cables Supplied

NOTE 1: PDP-10 Systems normally operate from 3-phase (WYE connected), 115v \pm 10%, 60 Hz \pm 2 Hz, or 230v \pm 10%, 50 Hz \pm 2 Hz phase to neutral. This device has a separate power cord using 5-wire 20A (three phase) Hubbel Twistlock Connectors. An earth/ground connection must be supplied through the power cord in addition to the ground bus requirements.

NOTE 2: For use within North America, this device will have a 5-wire Hubbel #3521 (mates with Hubbel #3520) power cord cap (male plug) supplied on the end of a 25-foot cord.

For use outside of North America, this device will have a pressure-type terminal strip suitable for 8 to 18 gauge wire enclosed inside the equipment's power control.

The descriptions, specifications, and prices contained herein were in effect at the time of approval for printing. Digital Equipment Corporation reserves the right to change descriptions, prices, specifications, or designs without notice and without incurring obligation.

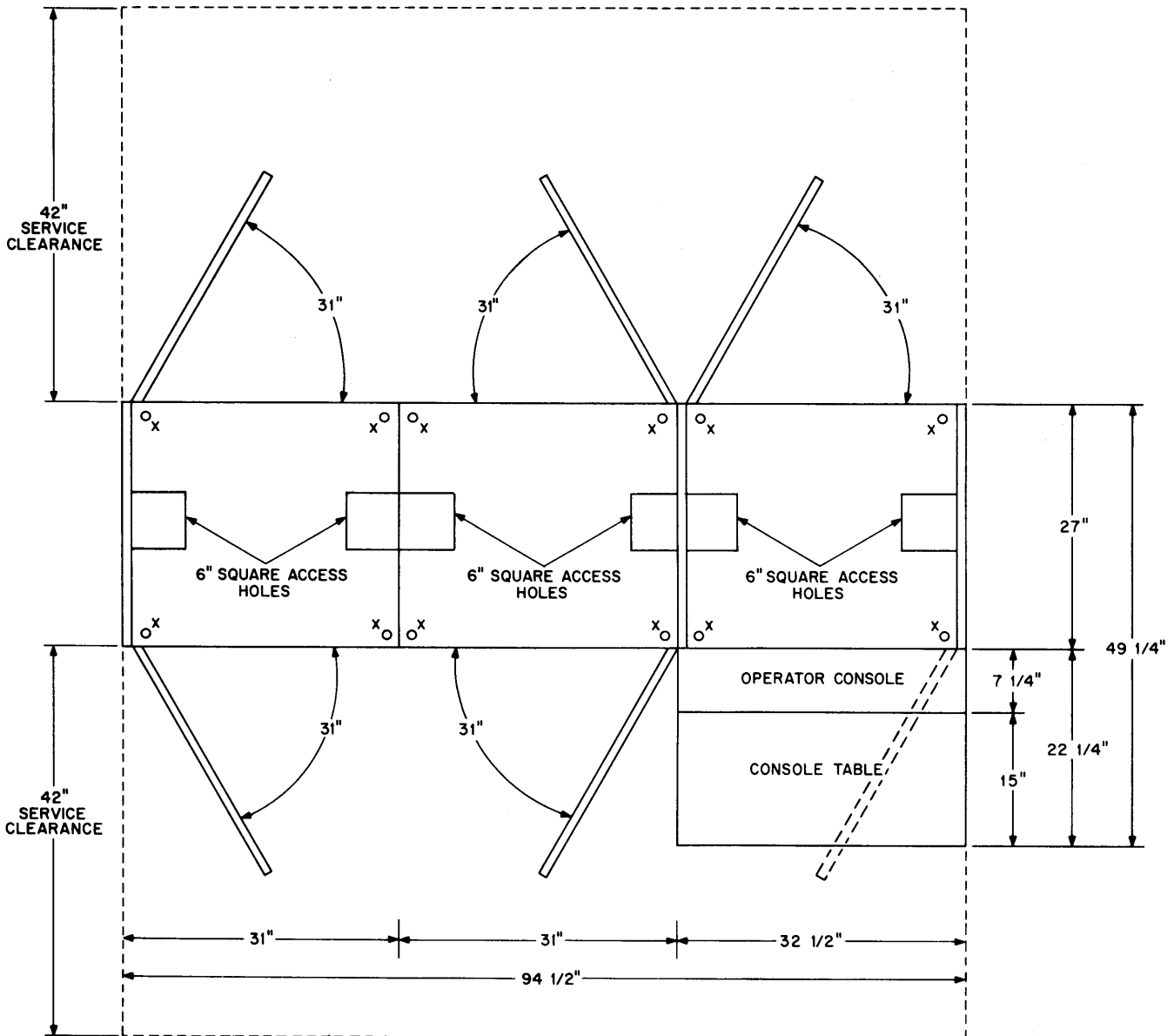

X = ADJUSTABLE FEET
 O = CASTERS (29/32" r
 AT POINT OF CONTACT)

CABINET FRONT

KA10 CENTRAL PROCESSOR

PDP-10 installation data

MA10 MA10A CORE MEMORY

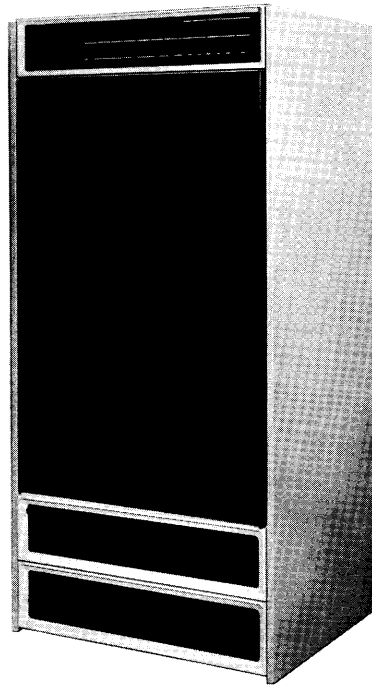

Description

The MA10 Core Memory Module contains 16,384 37-bit storage locations. MA10A Core Memory Module contains 8,192 37-bit storage locations. Both memories contain 36 data bits and 1 bit for parity checking. Both have a complete cycle time of 1 μ s. The central processor can directly address 262,144 words of core memory. A memory-processor bus connects the processor to each memory via one of its four memory ports. Up to four processors can access any one memory.

Memory modules are free standing, i.e., not bolted to the processor or an I/O option. Up to four memory modules may be bolted together (120 in.). The first memory module may not be more than three feet from the KA10 Processor. It may be as close as 1/4 in.

Note that the maximum total memory-bus length is 100 ft of cable length. Greater cable lengths than this will result in timing conflicts of memory bus signals.

Physical Specifications

Voltage (AC)	Current (A) Nominal @ 115V	Power Dissipation (W)	Heat Dissipation (Btu/hr)	Dimensions (inches)	Service Clearance (inches)	Weight (lbs)	Operating Temperature (min-max F)	Storage Temperature (min-max F)	Humidity (Rel) (min-max)	Maximum Wet Bulb	Maximum Cable Length
See Note 1 Note 2	15	1600	5440	Height 69 Width 32-3/4 Depth 27	Front 42 Rear 42	750	60° to 95°	40° to 110°	20% to 80%	78°F	100 (Mem. bus)

NOTE 1: PDP-10 Systems normally operate from 3-phase (WYE connected), 115v \pm 10%, 60 Hz \pm 2 Hz, or 230v \pm 10%, 50 Hz \pm 2 Hz phase to neutral. This device has a separate power cord using 3-wire 30A (single phase) Hubbel Twistlock Connectors. An earth/ground connection must be supplied through the power cord in addition to the ground bus requirements.

NOTE 2: For use within North America, this device will have a 3-wire Hubbel #3331 (mates with Hubbel #3330) power cord cap (male plug) supplied on the end of a 25-foot cord.

For use outside of North America, this device will have a pressure-type terminal strip suitable for 8 to 18 gauge wire enclosed inside the equipment's power control.

The descriptions, specifications, and prices contained herein were in effect at the time of approval for printing. Digital Equipment Corporation reserves the right to change descriptions, prices, specifications, or designs without notice and without incurring obligation.

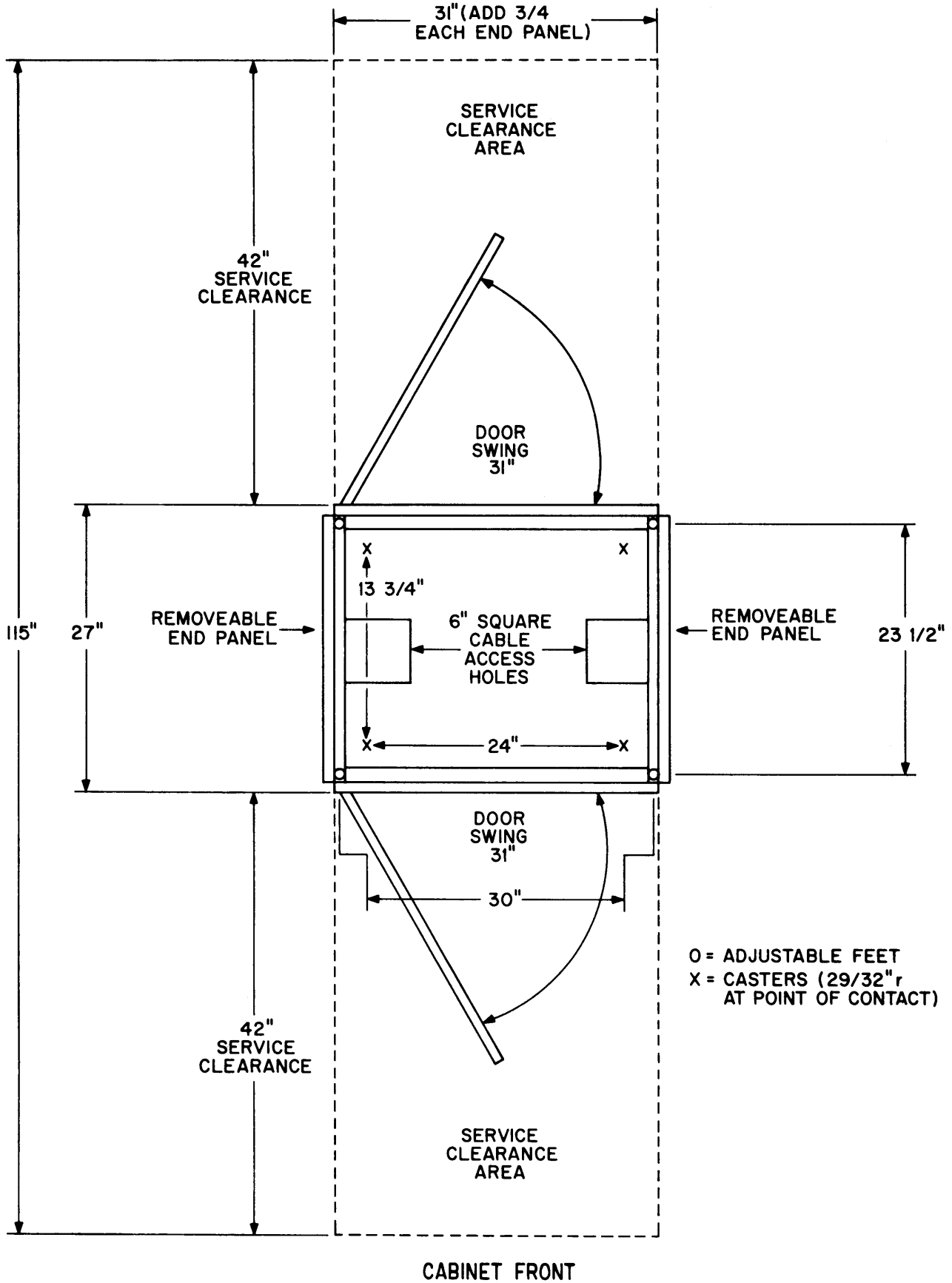

MA10 MA10A CORE MEMORY

PDP-10 installation data

MB10 CORE MEMORY

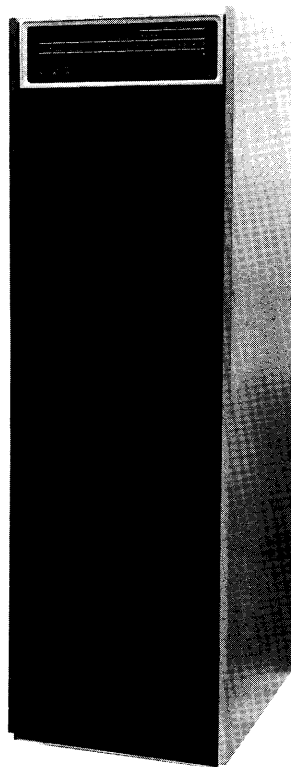

Description

The MB10 Core Memory Module contains 16,384 37-bit storage locations. MB10 memory locations contain 36 data bits and 1 bit for parity checking. The central processor can directly address 262,144 words of core memory. It has a complete cycle time of 1.65 μ s. A memory-processor bus connects the processor to each memory via one of its four memory ports. Up to four processors can access any one memory.

MB10 memories must always be located on the end of the memory bus in a system containing both MA10 and MB10 memories.

Location of memories on the bus bears no relation to the addresses of memory locations within that memory. The addresses can be selected by means of switches to be any integral set of 16K locations.

Physical Specifications

Voltage (AC)	Current (A) Nominal @ 115V	Power Dissipation (W)	Heat Dissipation (Btu/hr)	Dimensions (inches)	Service Clearance (inches)	Weight (lbs)	Operating Temperature (min-max F)	Storage Temperature (min-max F)	Humidity (Rel) (min-max)	Maximum Wet Bulb	Maximum Cable Length
See Note 1 Note 2	11	995	3396	Height 69 Width 21-1/4 Depth 27	Front 36 Rear 36	560	60° to 95°	40° to 110°	20% to 80%	78°F	100 ft (Mem bus)

NOTE 1: PDP-10 Systems normally operate from 3-phase (WYE connected), 115v \pm 10%, 60 Hz \pm 2 Hz, or 230v \pm 10%, 50 Hz \pm 2 Hz phase to neutral. This device has a separate power cord using 3-wire 30A (single phase) Hubbel Twistlock Connectors. An earth/ground connection must be supplied through the power cord in addition to the ground bus requirements.

NOTE 2: For use within North America, this device will have a 3-wire Hubbel #3331 (mates with Hubbel #3330) power cord cap (male plug) supplied on the end of a 25-foot cord.

For use outside of North America, this device will have a pressure-type terminal strip suitable for 8 to 18 gauge wire enclosed inside the equipment's power control.

PDP-10 installation data

DF10 DATA CHANNEL

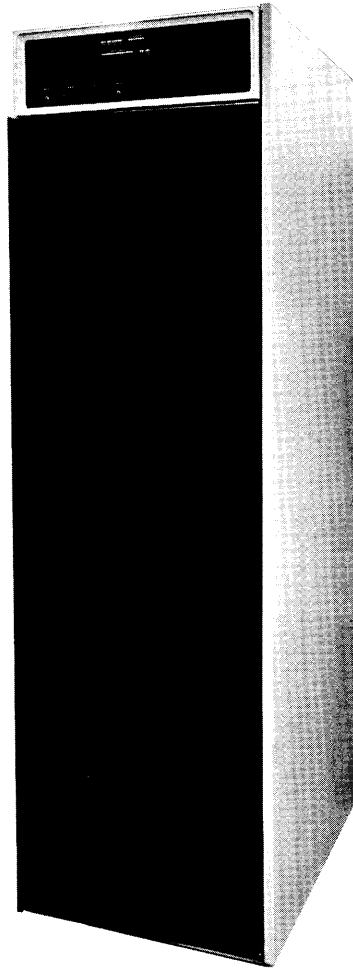

Description

DF10 Data Channel controls high-speed data transfers between external devices and the PDP-10 memory independently of the arithmetic processor. The channel is an I/O processor which will allow

block transfers, scatter transfers, and jump-type operations. It is capable of servicing up to eight external devices.

Physical Specifications

Voltage (AC)	Current (A) Nominal @ 115V	Power Dissipation (W)	Heat Dissipation (Btu/hr)	Dimensions (inches)	Service Clearance (inches)	Weight (lbs)	Operating Temperature (min-max F)	Storage Temperature (min-max F)	Humidity (Rel) (min-max)	Maximum Wet Bulb	Maximum Cable Length
See Note 1 Note 2	4.0	450	1550	Height 69 Width 21-1/4 Depth 27	Front 36 Rear 36	200	60° to 95°	40° to 110°	20% to 80%	78°F	100 ft (Mem bus & Chan bus)

NOTE 1: PDP-10 Systems normally operate from 3-phase (WYE connected), 115v ± 10%, 60 Hz ± 2 Hz, or 230v ± 10%, 50 Hz ± 2 Hz phase to neutral. This device has a separate power cord using 3-wire 30A (single phase) Hubbel Twistlock Connectors. An earth/ground connection must be supplied through the power cord in addition to the ground bus requirements.

NOTE 2: For use within North America, this device will have a 3-wire Hubbel #3331 (mates with Hubbel #3330) power cord cap (male plug) supplied on the end of a 25-foot cord.

For use outside of North America, this device will have a pressure-type terminal strip suitable for 8 to 18 gauge wire enclosed inside the equipment's power control.

PDP-10 installation data

RC10 DISC ADAPTOR

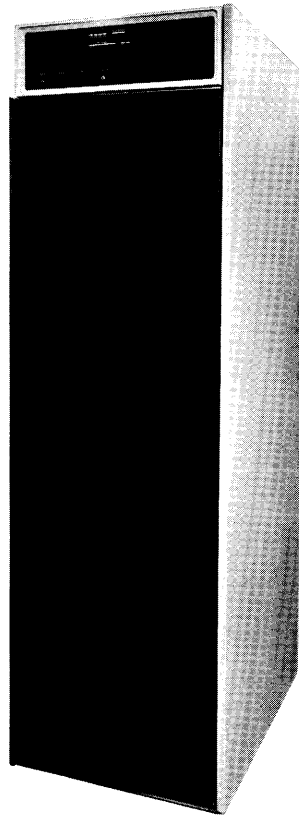

Description

RC10 Disc Synchronizer/Adapter is the device control for the RD10 Disc File. The RC10 interconnects to both the I/O Bus and the Data Channel. Control information is obtained via the I/O Bus, Data via the Channel Bus. Placement of this option is governed by the I/O bus cables, discs,

and data channel. See typical floor layouts for optimum location.

Each RC10 may connect up to four disc units. Each disc has a separate cable connection to the RC10. The length of each cable cannot exceed 50 ft.

Physical Specifications

Voltage (AC)	Current (A) / Nominal @ 115V	Power Dissipation (W)	Heat Dissipation (Btu/hr)	Dimensions (inches)	Service Clearance (inches)	Weight (lbs)	Operating Temperature (min-max F)	Storage Temperature (min-max F)	Humidity (Rel) (min-max)	Maximum Wet Bulb	Maximum Cable Length
See Note 1 Note 2	4	500	1700	Height 69 Width 21-1/4 Depth 27	Front 36 Rear 36	350	60° to 95°	40° to 110°	20% to 80%	78°F	100 ft (Chan bus) 150 ft (I/O bus)

NOTE 1: PDP-10 Systems normally operate from 3-phase (WYE connected), 115v ± 10%, 60 Hz ± 2 Hz, or 230v ± 10%, 50 Hz ± 2 Hz phase to neutral. This device has a separate power cord using 3-wire 30A (single phase) Hubbel Twistlock Connectors. An earth/ground connection must be supplied through the power cord in addition to the ground bus requirements.

NOTE 2: For use within North America, this device will have a 3-wire Hubbel #3331 (mates with Hubbel #3330) power cord cap (male plug) supplied on the end of a 25-foot cord.

For use outside of North America, this device will have a pressure-type terminal strip suitable for 8 to 18 gauge wire enclosed inside the equipment's power control.

PDP-10 installation data

RD10
DISC FILE

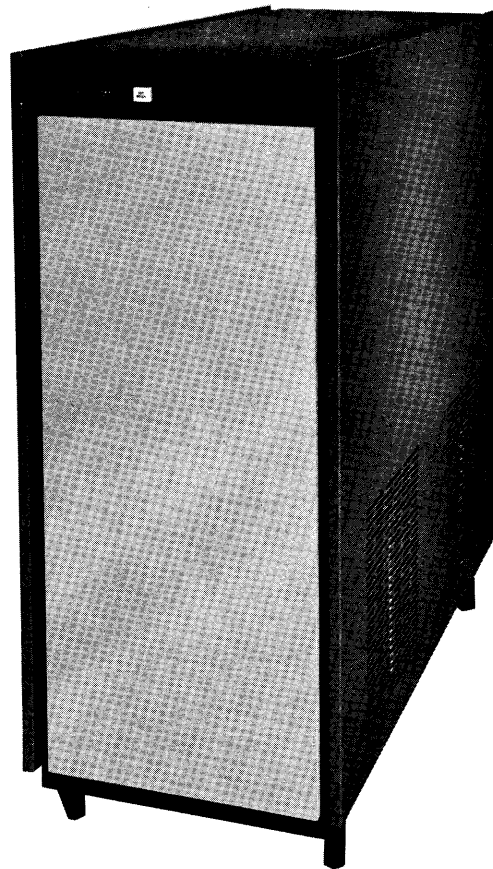

Description

RD10 Disc File stores 512,000 36-bit words organized in 200 tracks, each with 80 segments of 32 words. Error checking is performed on each 32 word segment. Up to four RD10 Disc File Units may connect to each RC10 Disc Synchronizer/Adapter. The maximum cable length is 50 ft.

Physical Specifications

Voltage (AC)	Current (A) Nominal @ 115V	Power Dissipation (W)	Heat Dissipation (Btu/hr)	Dimensions (inches)	Service Clearance (inches)	Weight (lbs)	Operating Temperature (min-max F)	Storage Temperature (min-max F)	Humidity (Rel) (min-max)	Maximum Wet Bulb	Maximum Cable Length
See Note 1 Note 2	3.5, ϕ_1 3.5, ϕ_2 0, ϕ_3	800	2850	Height 45 Width 22 Depth 45	Front 30 Rear 30	225	60° to 95°	40° to 110°	20% to 80%	78°F	50 ft

NOTE 1: PDP-10 Systems normally operate from 3-phase (WYE connected), 115v \pm 10%, 60 Hz \pm 2 Hz, or 230v \pm 10%, 50 Hz \pm 2 Hz phase to neutral. This device has a separate power cord using 5-wire 20A (three phase) Hubbel Twistlock Connectors. An earth/ground connection must be supplied through the power cord in addition to the ground bus requirements.

NOTE 2: For use within North America, this device will have a 5-wire Hubbel #3521 (mates with Hubbel #3520) power cord cap (male plug) supplied on the end of a 25-foot cord.

For use outside of North America, this device will have a pressure-type terminal strip suitable for 8 to 18 gauge wire enclosed inside the equipment's power control.

The descriptions, specifications, and prices contained herein were in effect at the time of approval for printing. Digital Equipment Corporation reserves the right to change descriptions, prices, specifications, or designs without notice and without incurring obligation.

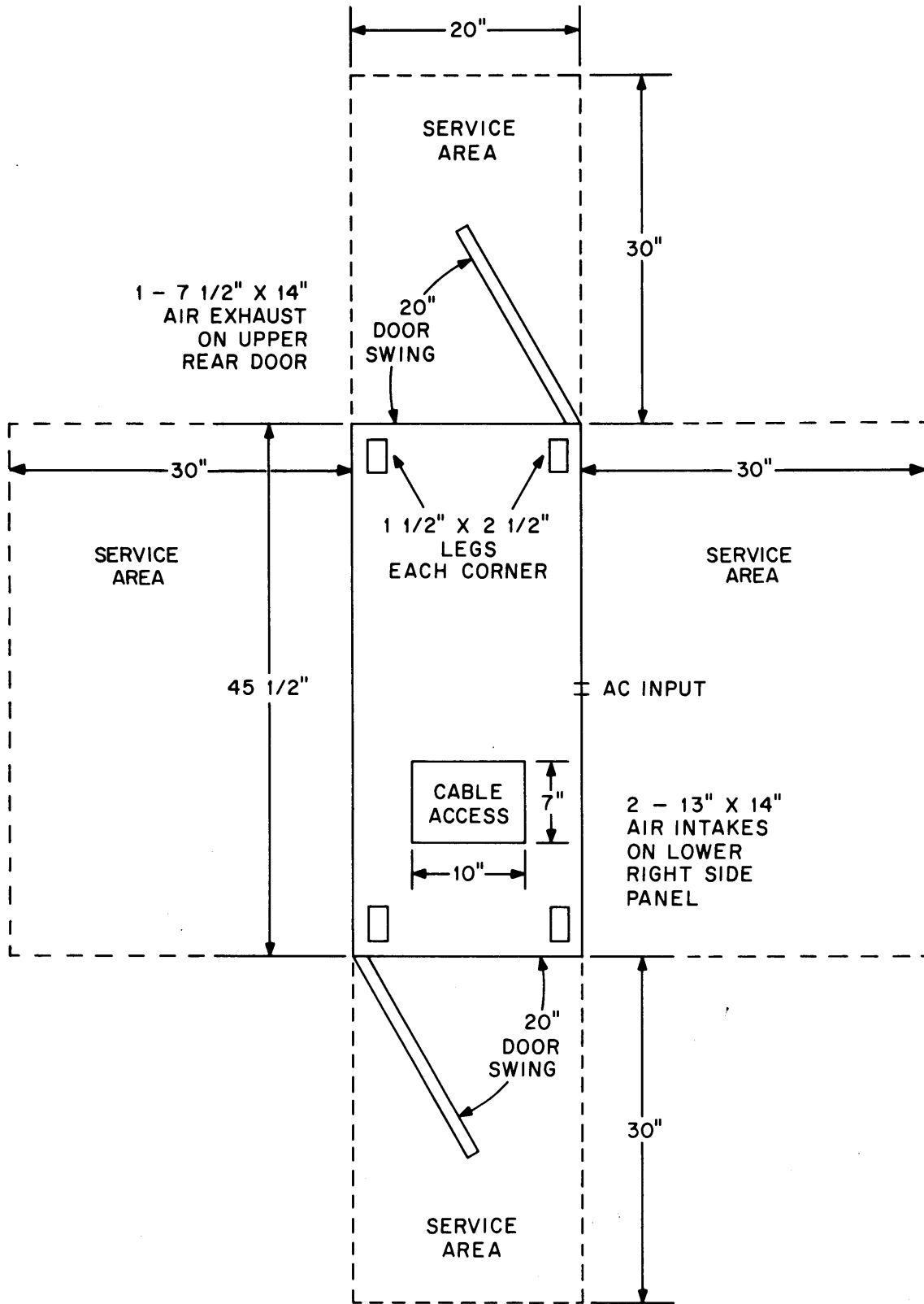

FRONT OF CABINET

RD10 DISC FILE

PDP-10 installation data

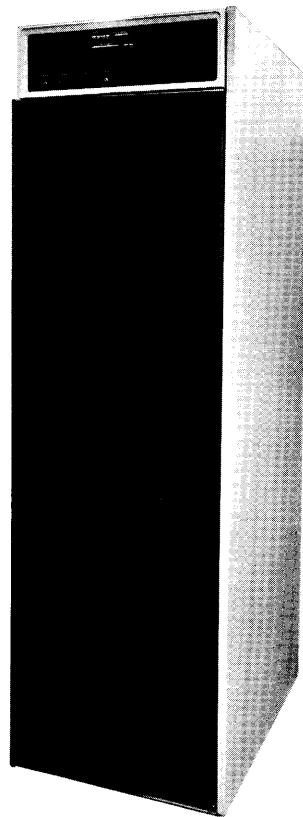

BA10 COMBINED CONTROL

Description

The BA10 is a combined control for the Line Printer, Card Reader, and X-Y Plotter. Information and command flow is over the I/O Bus and the cabinet should be located to minimize I/O Bus cable lengths.

card reader on and off. The card reader's power is remotely controlled from the controller.

Device cables are connected radially and should be located to provide free and clear access to each unit. Indicator lamps at the top of the control cabinet and at each device should be easily visible by the computer operator.

Current and power figures were measured with the

Physical Specifications

Voltage (AC)	Current (A) Nominal @ 115V	Power Dissipation (W)	Heat Dissipation (Btu/hr)	Dimensions (inches)	Service Clearance (inches)	Weight (lbs)	Operating Temperature (min-max F)	Storage Temperature (min-max F)	Humidity (Rel) (min-max)	Maximum Wet Bulb	Maximum Cable Length
See Note 1 Note 2	6 15	690 1725	2346 5865	Height 69 Width 21-1/4 Depth 27	Front 36 Rear 36	500	60° to 95°	40° to 110°	20% to 80%	78°F	150 ft

NOTE 1: PDP-10 Systems normally operate from 3-phase (WYE connected), 115v ± 10%, 60 Hz ± 2 Hz, or 230v ± 10%, 50 Hz ± 2 Hz phase to neutral. This device has a separate power cord using 3-wire 30A (single phase) Hubbel Twistlock Connectors. An earth/ground connection must be supplied through the power cord in addition to the ground bus requirements.

NOTE 2: For use within North America, this device will have a 3-wire Hubbel #3331 (mates with Hubbel #3330) power cord cap (male plug) supplied on the end of a 25-foot cord.

For use outside of North America, this device will have a pressure-type terminal strip suitable for 8 to 18 gauge wire enclosed inside the equipment's power control.

PDP-10 installation data

CR10 CARD READER



Description

CR10 Card Reader reads standard 80-column punched cards at the rate of up to 1000 cards per minute. The reader is a table-top unit provided with a free-standing table. The card reader control

is housed with LP10 Line Printer and XY10 Plotter Control in a separate 19 in. cabinet. The card reader control connects to the I/O bus.

Physical Specifications

Voltage (AC)	Current (A) Nominal @ 115V	Power Dissipation (W)	Heat Dissipation (Btu/hr)	Dimensions (inches)	Service Clearance (inches)	Weight (lbs)	Operating Temperature (min-max F)	Storage Temperature (min-max F)	Humidity (Rel) (min-max)	Maximum Wet Bulb	Maximum Cable Length
See Note 1 Note 2	16	1700	5800	Height 56 Width 64 Depth 36	Front 36 Rear 24	300	60° to 95°	40° to 110°	20% to 80%	78°F	25 ft
Cards must meet dimensional requirements, which usually limit temperature and humidity range.											

NOTE 1: PDP-10 Systems normally operate from 3-phase (WYE connected), 115v ± 10%, 60 Hz ± 2 Hz, or 230v ± 10%, 50 Hz ± 2 Hz phase to neutral. This device has a separate power cord using 3-wire 30A (single phase) Hubbel Twistlock Connectors. An earth/ground connection must be supplied through the power cord in addition to the ground bus requirements.

NOTE 2: For use within North America, this device will have a 3-wire Hubbel #3331 (mates with Hubbel #3330) power cord cap (male plug) supplied on the end of a 25-foot cord.

For use outside of North America, this device will have a pressure-type terminal strip suitable for 8 to 18 gauge wire enclosed inside the equipment's power control.

The descriptions, specifications, and prices contained herein were in effect at the time of approval for printing. Digital Equipment Corporation reserves the right to change descriptions, prices, specifications, or designs without notice and without incurring obligation.

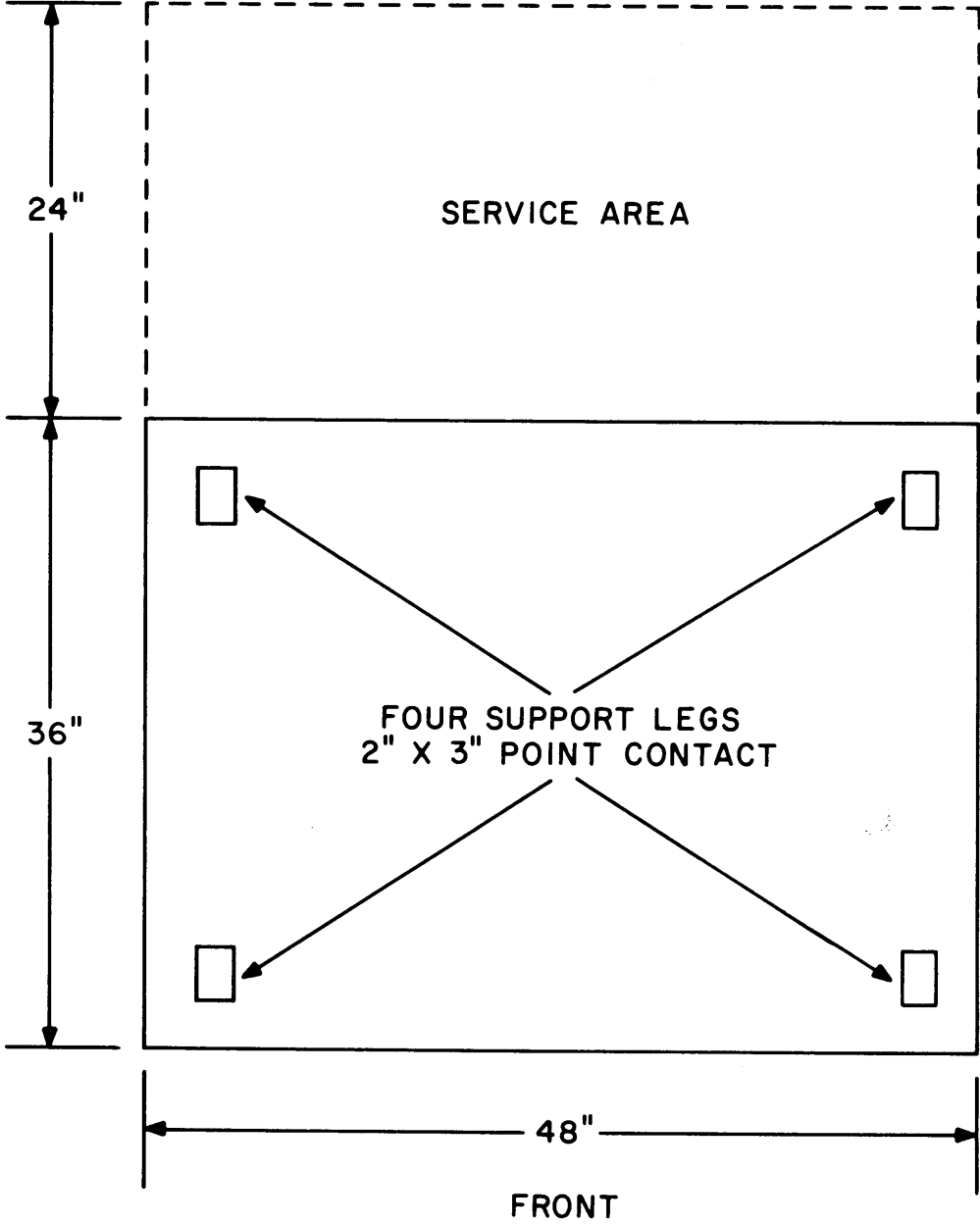

CR10 CARD READER

PDP-10 installation data

LP10A

LINE PRINTER

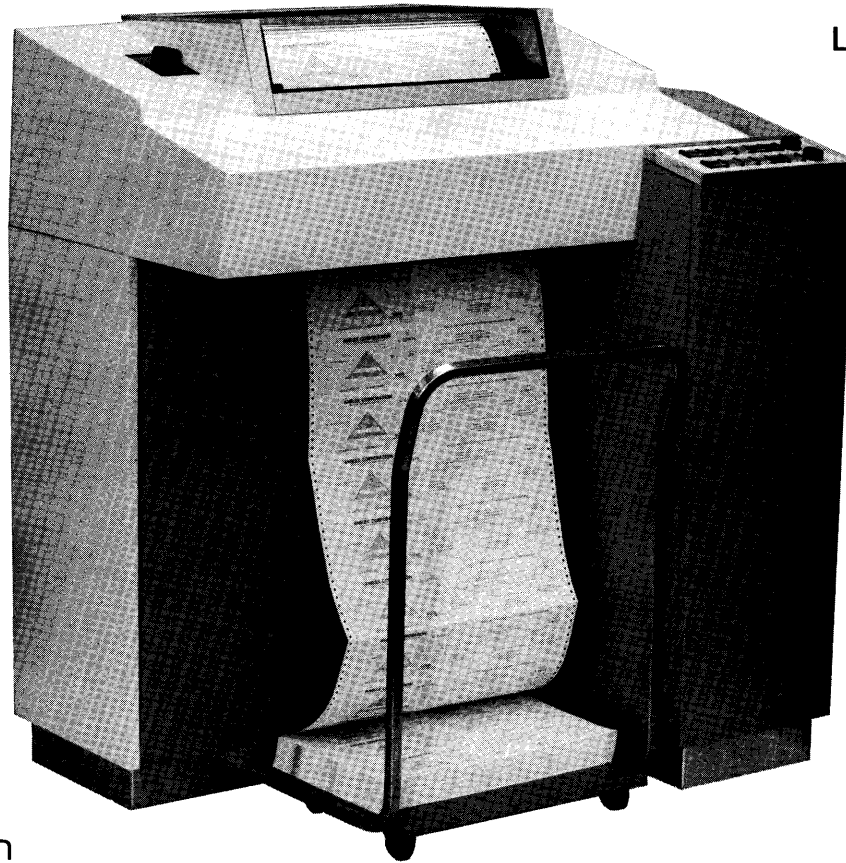

Description

LP10A Line Printer has a 64-character font and prints 132-column lines up to 300 lines per minute. It uses the PDP-10 modified USASCII code.

The control for the line printer is housed in the same 19 in. cabinet (BA10) as the CR10 Card Reader and XY10 Plotter Control.

Physical Specifications

Voltage (AC)	Current (A) Nominal (@ 115V)	Power Dissipation (W)	Heat Dissipation (Btu/hr)	Dimensions (inches)	Service Clearance (inches)	Weight (lbs)	Operating Temperature (min-max F)	Storage Temperature (min-max F)	Humidity (Rel) (min-max)	Maximum Wet Bulb	Maximum Cable Length
See Note 1 Note 2	20	2200	7500	Height 50-3/4 Width 42-5/8 Depth 29	Front 36 Rear 48	1100	60° to 95°	0° to 125°	40% to 80%	78°F	25 ft

NOTE 1: PDP-10 Systems normally operate from 3-phase (WYE connected), 115v \pm 10%, 60 Hz \pm 2 Hz, or 230v \pm 10%, 50 Hz \pm 2 Hz phase to neutral. This device has a separate power cord using 3-wire 30A (single phase) Hubbel Twistlock Connectors. An earth/ground connection must be supplied through the power cord in addition to the ground bus requirements.

NOTE 2: For use within North America, this device will have a 3-wire Hubbel #3331 (mates with Hubbel #3330) power cord cap (male plug) supplied on the end of a 25-foot cord.

For use outside of North America, this device will have a pressure-type terminal strip suitable for 8 to 18 gauge wire enclosed inside the equipment's power control.

The descriptions, specifications, and prices contained herein were in effect at the time of approval for printing. Digital Equipment Corporation reserves the right to change descriptions, prices, specifications, or designs without notice and without incurring obligation.

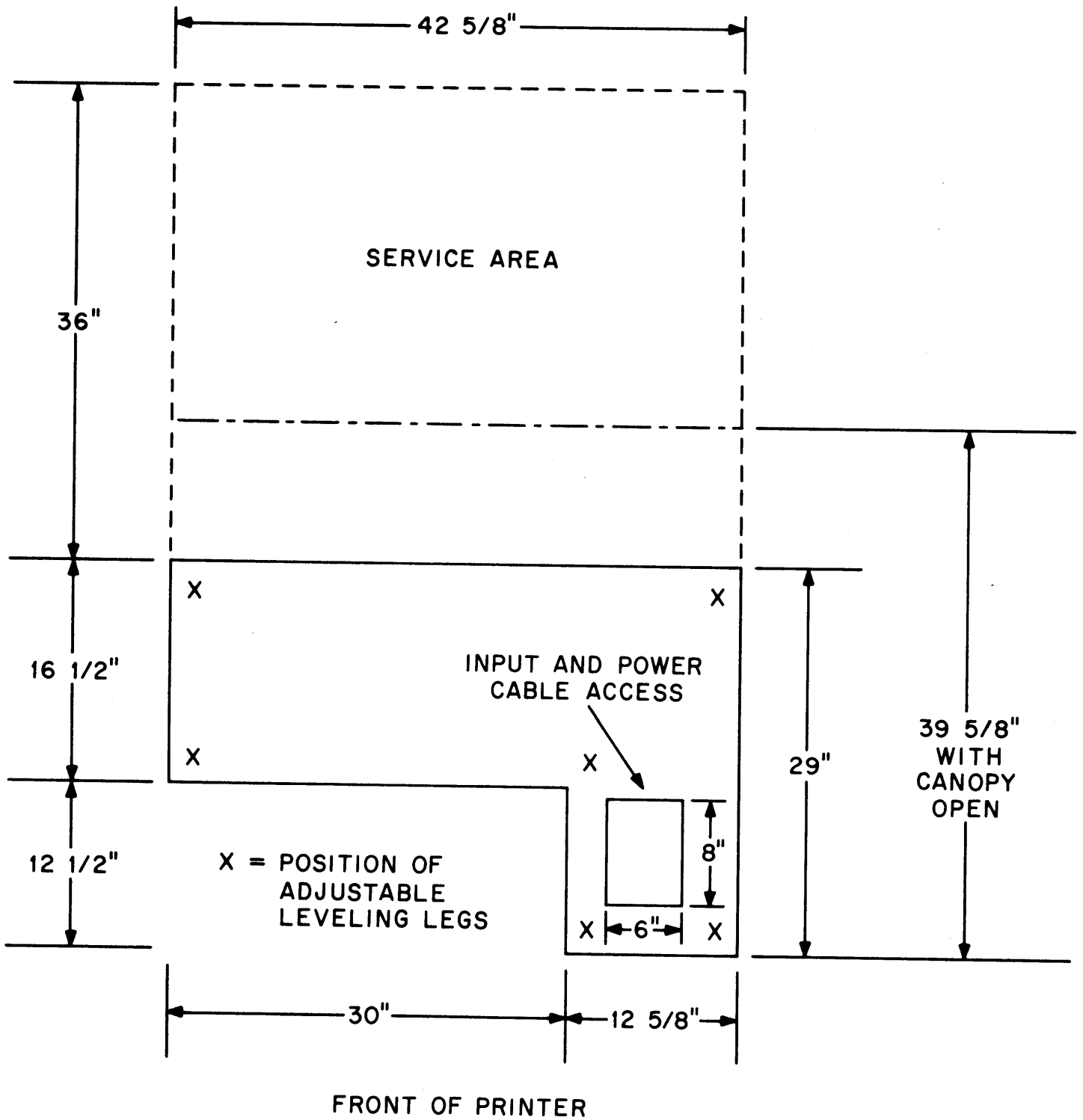

LP10A LINE PRINTER

PDP-10 installation data

LP10B LINE PRINTER



Description

LP10B Line Printer has a 64-character font and prints 132-column lines up to 600 lines per minute. It uses the PDP-10 modified USASCII code.

The control for the line printer is housed in the same 19 in. cabinet (BA10) as the CR10 Card Reader and XY10 Plotter Control.

Physical Specifications

Voltage (AC)	Current (A) Nominal @ 115V	Power Dissipation (W)	Heat Dissipation (Btu/hr)	Dimensions (inches)	Service Clearance (inches)	Weight (lbs)	Operating Temperature (min-max F)	Storage Temperature (min-max F)	Humidity (Rel) (min-max)	Maximum Wet Bulb	Maximum Cable Length
See Note 1 Note 2	30	3200	10,900	Height 55 Width 56 Depth 30	Sides 36 Rear 36	1600	60° to 95°	0° to 125°	40% to 80%	78°F	25 ft

NOTE 1: PDP-10 Systems normally operate from 3-phase (WYE connected), 115v \pm 10%, 60 Hz \pm 2 Hz, or 230v \pm 10%, 50 Hz \pm 2 Hz phase to neutral. This device has a separate power cord using 3-wire 30A (single phase) Hubbel Twistlock Connectors. An earth/ground connection must be supplied through the power cord in addition to the ground bus requirements.

NOTE 2: For use within North America, this device will have a 3-wire Hubbel #3331 (mates with Hubbel #3330) power cord cap (male plug) supplied on the end of a 25-foot cord.

For use outside of North America, this device will have a pressure-type terminal strip suitable for 8 to 18 gauge wire enclosed inside the equipment's power control.

The descriptions, specifications, and prices contained herein were in effect at the time of approval for printing. Digital Equipment Corporation reserves the right to change descriptions, prices, specifications, or designs without notice and without incurring obligation.

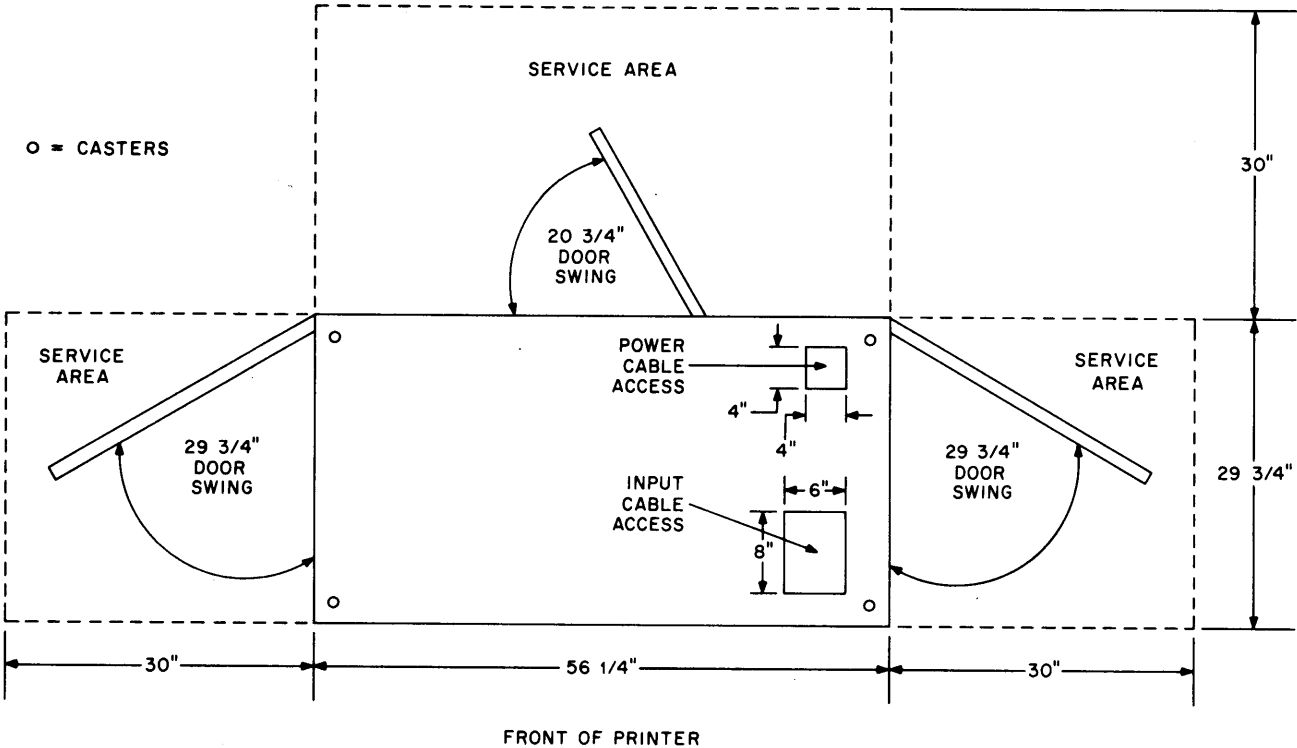

LP10B LINE PRINTER

PERIPHERAL EQUIPMENT ENVIRONMENTAL AND PHYSICAL SPECIFICATIONS

	KA10 Central Processor	MA10 MA10A Memory 1.0 μ s	MB10 Memory 1.65 μ s	DF10 Data Channel	RC10 Disc/Synch Adaptor	RD10 Disc File	CR10 Card Reader	LP10A 300 lpm Line Printer	LP10B 600 lpm Line Printer	LP 100 Li Pri
Voltage (AC)	Note 1, 2	Note 1, 2	Note 1, 2	Note 1, 2	Note 1, 2	Note 1, 2	Note 1, 2	Note 1, 2	Note 1, 2	Note
Current (A) @ 115V (nominal)	13 20 /phase	15	11	4.0	4	***	16	20	30	30
Power Dissipation (w)	4 4300	1 1600	995	450 650	500 650	800 1000	1700	2200	300 900	268
Heat Dissipation (BTU/hr.)	14,700	5,440	3,396	1550	1700	2850	5800	7500	10,900	10
Dimension (inches)	31" Cab Height 69 Width 98 Depth 34-1/2 (w/console) 27 (no console)	31" Cab Height 69 Width 32-1/2 Depth 27	19" Cab Height 69 Width 21-1/4 Depth 27	19" Cab Height 69 Width 21-1/4 Depth 27	19" Cab Height 69 Width 21-1/4 Depth 27	45 22 45	36 64 36 Requires BA10 Cab. for control	50-3/4 42-5/8 29 Requires BA10 Cab. for control	55 56 30 Requires BA10 Cab. for control	Req. Cab.
Service Clearance (inches)										
Front	42	42	36	36	36	30	36	36	Sides 36	
Rear	42	42	36	36	36	30 (sides 36)	24	48	Rear 36	
Weight (lbs.)	1920	750	560	200	350	225	300	1100	1600	1
Environmental Requirements (min.-max.)										
Operating Temp (F)	60° to 95°	60° to 95°	60° to 95°	60° to 95°	60° to 95°	60° to 95°	60° to 95°	60° to 95°	60° to 95°	60°
Storage Temp (F)	40° to 110°	40° to 110°	40° to 110°	40° to 110°	40° to 110°	40° to 110°	40° to 110°	40° to 110°	0° to 125°	-30°
Humidity (Rel)	20% to 80%	20% to 80%	20% to 80%	20% to 80%	20% to 80%	20% to 80%	20% to 80%	20% to 80%	40% to 80%	40%
Wet Bulb (Max. F)	78°	78°	78°	78°	78°	78°	78°	78°	78°	78°

NOTE 1: PDP-10 Systems normally operate from 3-phase (WYE connected), 115v \pm 10%, 60 Hz \pm 2 Hz or 112.5, 123.5, 195, 220, 230v \pm 10% 50 Hz \pm 2 Hz phase to neutral. Individual devices have separate power cords using either 3-wire 30A (single phase), or 5-wire 20A (three phase) Hubbel Twistlock Connectors. An earth/ground connection must be supplied through the power cord in addition to the ground bus requirements.

NOTE 2: Equipment for use within North America will have the following connectors (male plugs) supplied on the end of 25 foot line cords.
3-wire Hubbel #3331 (mates with Hubbel #3330)
5-wire Hubbel #3521 (mates with Hubbel #3520)

Equipment for use outside of North America will have a pressure-type terminal strip suitable for 8 to 18 gauge wire enclosed inside of the equipment's power control.

NOTE 3: The description and specifications contained herein were in effect at the time of approval for printing. Digital Equipment Corporation reserves the right to change descriptions, specifications, or designs without notice and without incurring obligation.

m	TM10 Magtape Control	TU20 Magtape Transport	TU79 Magtape Transport	TD10 DECtape Control *	TU55 DECtape Transport	DC10 Dataline Scanner **	346/340 CRT Display	348/VR30 CRT Display	XY10 Calcomp Plotter 11"	XY10 Calcomp Plotter 29"	DA10 PDP-8/9 Interface
2	Note 1, 2	Note 1, 2	Note 1, 2	Note 1, 2	Note 1, 2	Note 1, 2	Note 1, 2	Note 1, 2	Note 1, 2	Note 1, 2	Note 1, 2
	3 40	6.75	10	2.5	1	11	15	7	1.5	1.5	2.0
	300 500	750 1000	1200	200	150	1000	1730	805	200	200	230
	1020	2570	4100	682	510	3410	5900	2750	682	682	800
BA10 ontrol	19" Cab 69 21-1/4 27	19" Cab 69 21-1/4 27	31" Cab 71 32-1/2 27	19" Cab 69 21-1/4 27	Mounts in Existing Cabinets Height 10-1/2	19" Cab 69 21-1/4 27	69 42 54	69 21-1/4 27	9-3/4 18 9-3/4 Requires BA10 Cab. for control	9-3/4 39-1/2 14-1/2 Requires BA10 Cab. for control	19" Cab 69 21-1/4 27
	36 36	21 21	60 72 (side: 40")	36 36	16-3/4 (Front)	36 36	36	Top 24 36 36	- -	- -	36 36
	300	300	800	500	40	500	700	360	50	95	300
5° 30° 0%	60° to 95° 40° to 110° 20% to 80% 78°	60° to 90° 40° to 110° 40% to 80% 78°	60° to 80° 40° to 110° 40% to 80% 78°	60° to 95° 40° to 110° 20% to 80% 78°	60° to 80° 40° to 110° 40% to 60% 78°	60° to 95° 40° to 110° 20% to 80% 78°	60° to 95° 40° to 110° 20% to 80% 78°	60° to 95° 40° to 110° 20% to 80% 78°	60° to 95° 40° to 110° 20% to 80% 78°	60° to 95° 40° to 110° 20% to 80% 78°	60° to 95° 40° to 110° 20% to 80% 78°

* More than 5 TU55's require TD10B Extender Cabinet

** Approximately 32 lines, one full cabinet

*** See Specification sheet

PDP-10 installation data

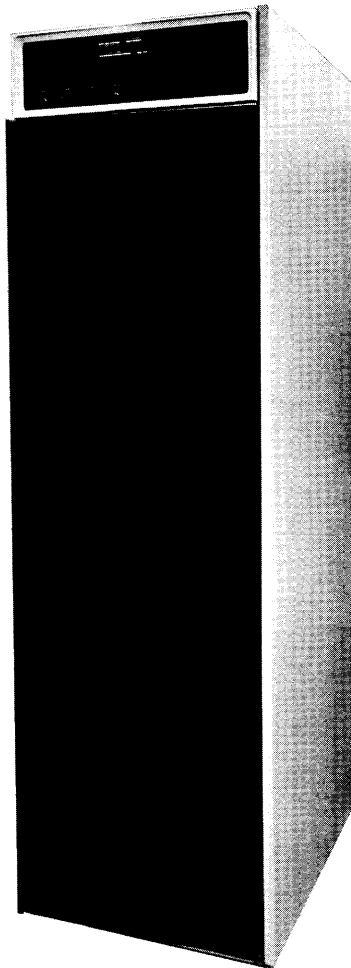

TM10 TAPE CONTROL

Description

TM10 is the Magnetic Tape Control for the TU20 (36KC) and TU79 (60KC) Tape Transports. It can control up to a total of eight transports, all 36KC, all 60KC, or a mix of both. The transports can be either seven or nine channel or mixes of both.

Physical Specifications

Voltage (AC)	Current (A) Nominal @ 115V	Power Dissipation (W)	Heat Dissipation (Btu/hr)	Dimensions (inches)	Service Clearance (inches)	Weight (lbs)	Operating Temperature (min-max F)	Storage Temperature (min-max F)	Humidity (Rel) (min-max)	Maximum Wet Bulb	Maximum Cable Length
See Note 1 Note 2	3	300	1020	Height 69 Width 21-1/4 Depth 27	Front 36 Rear 36	500	60° to 95°	40° to 110°	20% to 80%	78°F	150 ft (I/O bus) 100 ft (Device cable)

NOTE 1: PDP-10 Systems normally operate from 3-phase (WYE connected), 115v \pm 10%, 60 Hz \pm 2 Hz, or 230v \pm 10%, 50 Hz \pm 2 Hz phase to neutral. This device has a separate power cord using 3-wire 30A (single phase) Hubbel Twistlock Connectors. An earth/ground connection must be supplied through the power cord in addition to the ground bus requirements.

NOTE 2: For use within North America, this device will have a 3-wire Hubbel #3331 (mates with Hubbel #3330) power cord cap (male plug) supplied on the end of a 25-foot cord.

For use outside of North America, this device will have a pressure-type terminal strip suitable for 8 to 18 gauge wire enclosed inside the equipment's power control.

The descriptions, specifications, and prices contained herein were in effect at the time of approval for printing. Digital Equipment Corporation reserves the right to change descriptions, prices, specifications, or designs without notice and without incurring obligation.

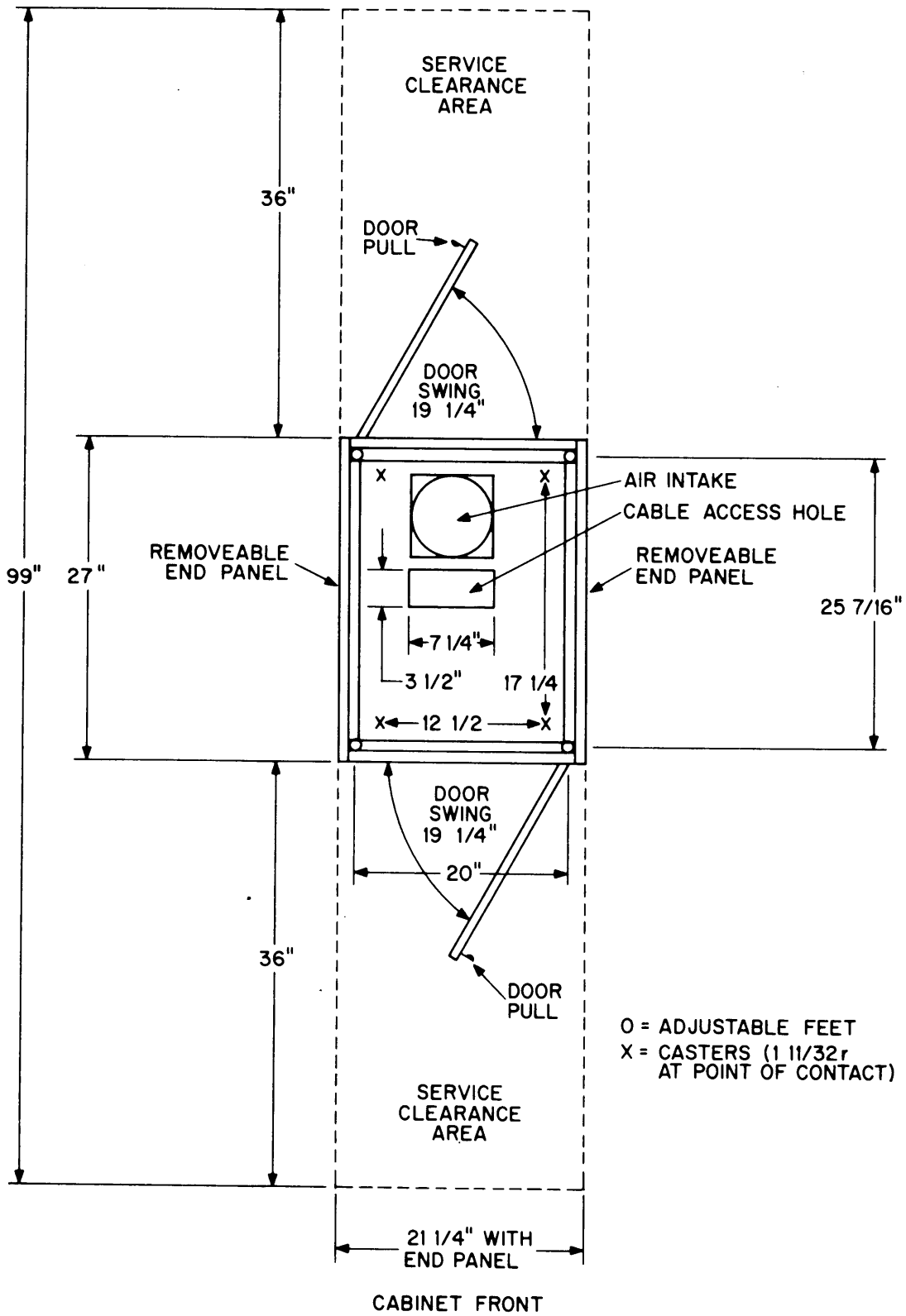

TM10 TAPE CONTROL

PDP-10 installation data

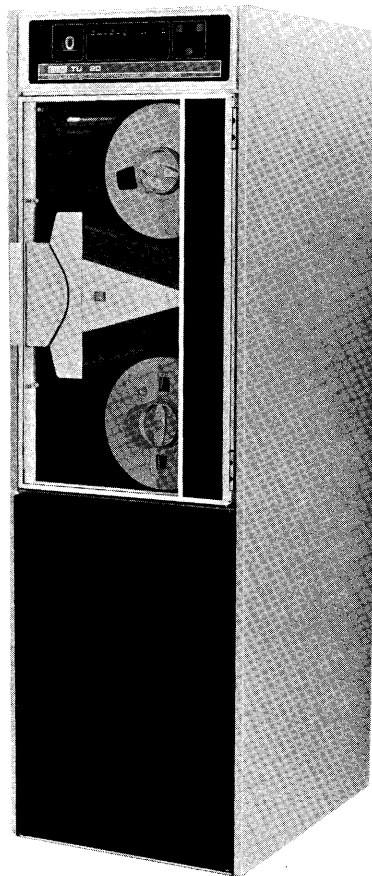

TU20 TAPE TRANSPORT

Description

The TU20 Magnetic Tape Transport reads or writes at the rate of 36,000 characters per second. Recording densities of 200, 556, or 800 bits-per-inch may be selected, at a tape speed of 45 in. per second. Seven or nine channel half-inch industry

standard (IBM compatible) tape is used. TU20 is housed in a stand-alone 19 in. cabinet, and may be butted side by side against other TU20s, as service clearance is front and rear, not on sides.

Physical Specifications

Voltage (AC)	Current (A) Nominal @ 115V	Power Dissipation (W)	Heat Dissipation (Btu/hr)	Dimensions (inches)	Service Clearance (inches)	Weight (lbs)	Operating Temperature (min-max F)	Storage Temperature (min-max F)	Humidity (Rel) (min-max)	Maximum Wet Bulb	Maximum Cable Length
See Note 1 Note 2	6.75	750	2570	Height 69 Width 21-1/4 Depth 27	Front 21 Rear 21	300	60° to 90°	40° to 110°	40% to 80%	78°F	100 ft

NOTE 1: PDP-10 Systems normally operate from 3-phase (WYE connected), 115v ± 10%, 60 Hz ± 2 Hz, or 230v ± 10%, 50 Hz ± 2 Hz phase to neutral. This device has a separate power cord using 3-wire 30A (single phase) Hubbel Twistlock Connectors. An earth/ground connection must be supplied through the power cord in addition to the ground bus requirements.

NOTE 2: For use within North America, this device will have a 3-wire Hubbel #3331 (mates with Hubbel #3330) power cord cap (male plug) supplied on the end of a 25-foot cord.

For use outside of North America, this device will have a pressure-type terminal strip suitable for 8 to 18 gauge wire enclosed inside the equipment's power control.

The descriptions, specifications, and prices contained herein were in effect at the time of approval for printing. Digital Equipment Corporation reserves the right to change descriptions, prices, specifications, or designs without notice and without incurring obligation.

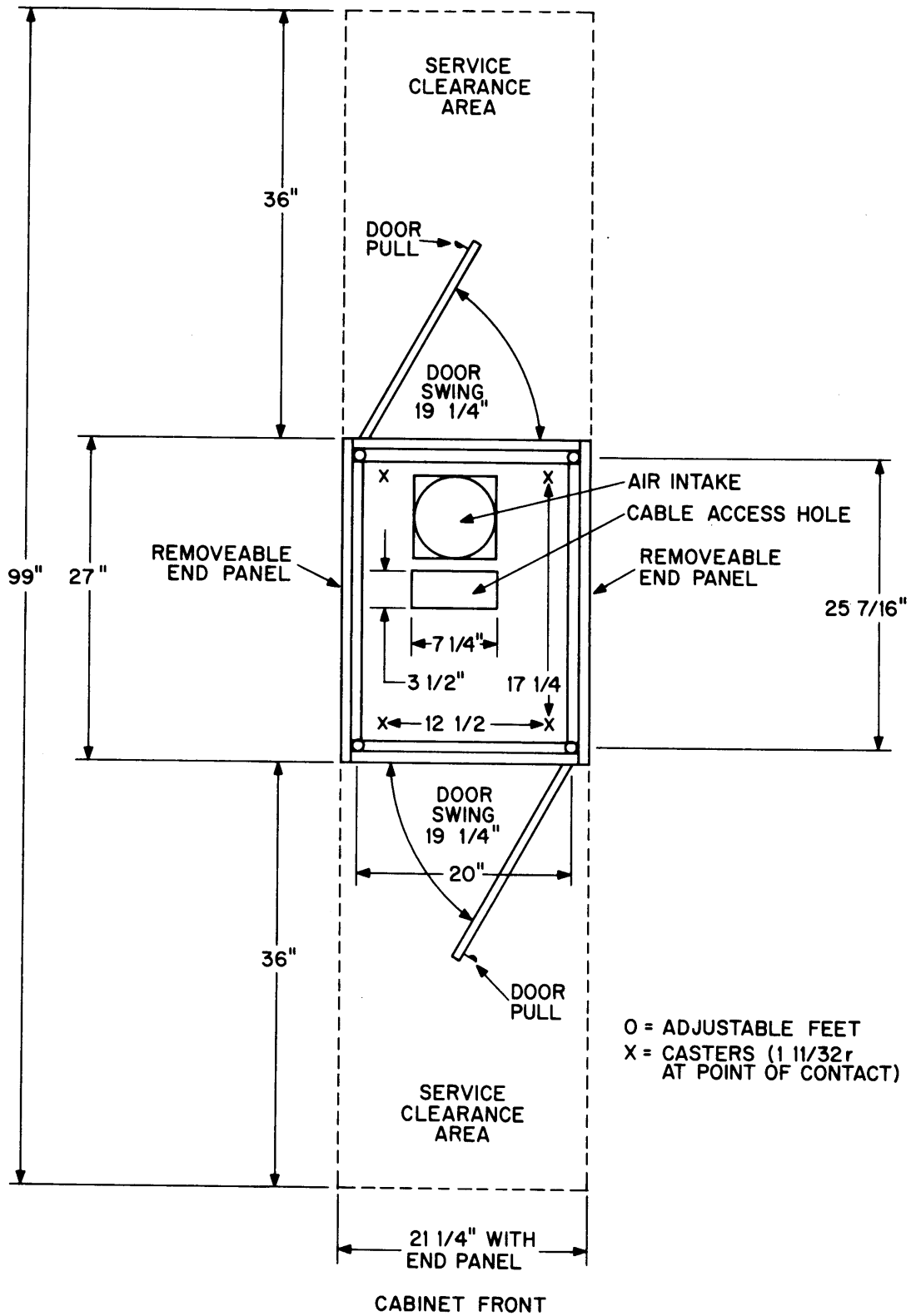

TU20 TAPE TRANSPORT

PDP-10 installation data

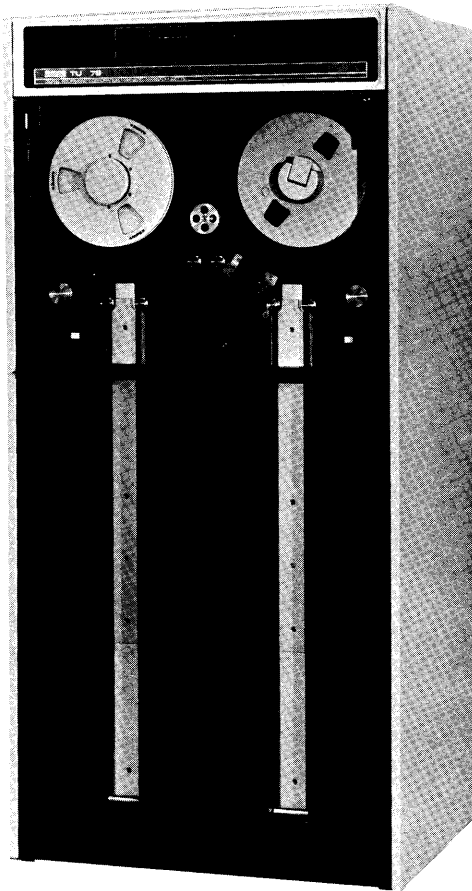

TU79 TAPE TRANSPORT

Description

The TU79 Magnetic Tape Transport is a single-capstan tape drive capable of reading or writing up to 60,000 characters per second at a recording density of 200, 556, or 800 bits-per-inch. Tape speed is 75 in. per second.

Industry standard (IBM compatible) half-inch 7 track tape is used. TU79 is housed in a 31 in. free-standing cabinet which may be butted side by side to other TU79s.

Physical Specifications

Voltage (AC)	Current (A) Nominal @ 115V	Power Dissipation (W)	Heat Dissipation (Btu/hr)	Dimensions (inches)	Service Clearance (inches)	Weight (lbs)	Operating Temperature (min-max F)	Storage Temperature (min-max F)	Humidity (Rel) (min-max)	Maximum Wet Bulb	Maximum Cable Length
See Note 1 Note 2	10	1200	4100	Height 71 Width 31-1/2 Depth 27	Front 60 Rear 72 (Side: 40)	800	60° to 80°	40° to 110°	40% to 80%	78°F	100 ft

NOTE 1: PDP-10 Systems normally operate from 3-phase (WYE connected), 115v \pm 10%, 60 Hz \pm 2 Hz, or 230v \pm 10%, 50 Hz \pm 2 Hz phase to neutral. This device has a separate power cord using 3-wire 30A (single phase) Hubbel Twistlock Connectors. An earth/ground connection must be supplied through the power cord in addition to the ground bus requirements.

NOTE 2: For use within North America, this device will have a 3-wire Hubbel #3331 (mates with Hubbel #3330) power cord cap (male plug) supplied on the end of a 25-foot cord.

For use outside of North America, this device will have a pressure-type terminal strip suitable for 8 to 18 gauge wire enclosed inside the equipment's power control.

The descriptions, specifications, and prices contained herein were in effect at the time of approval for printing. Digital Equipment Corporation reserves the right to change descriptions, prices, specifications, or designs without notice and without incurring obligation.

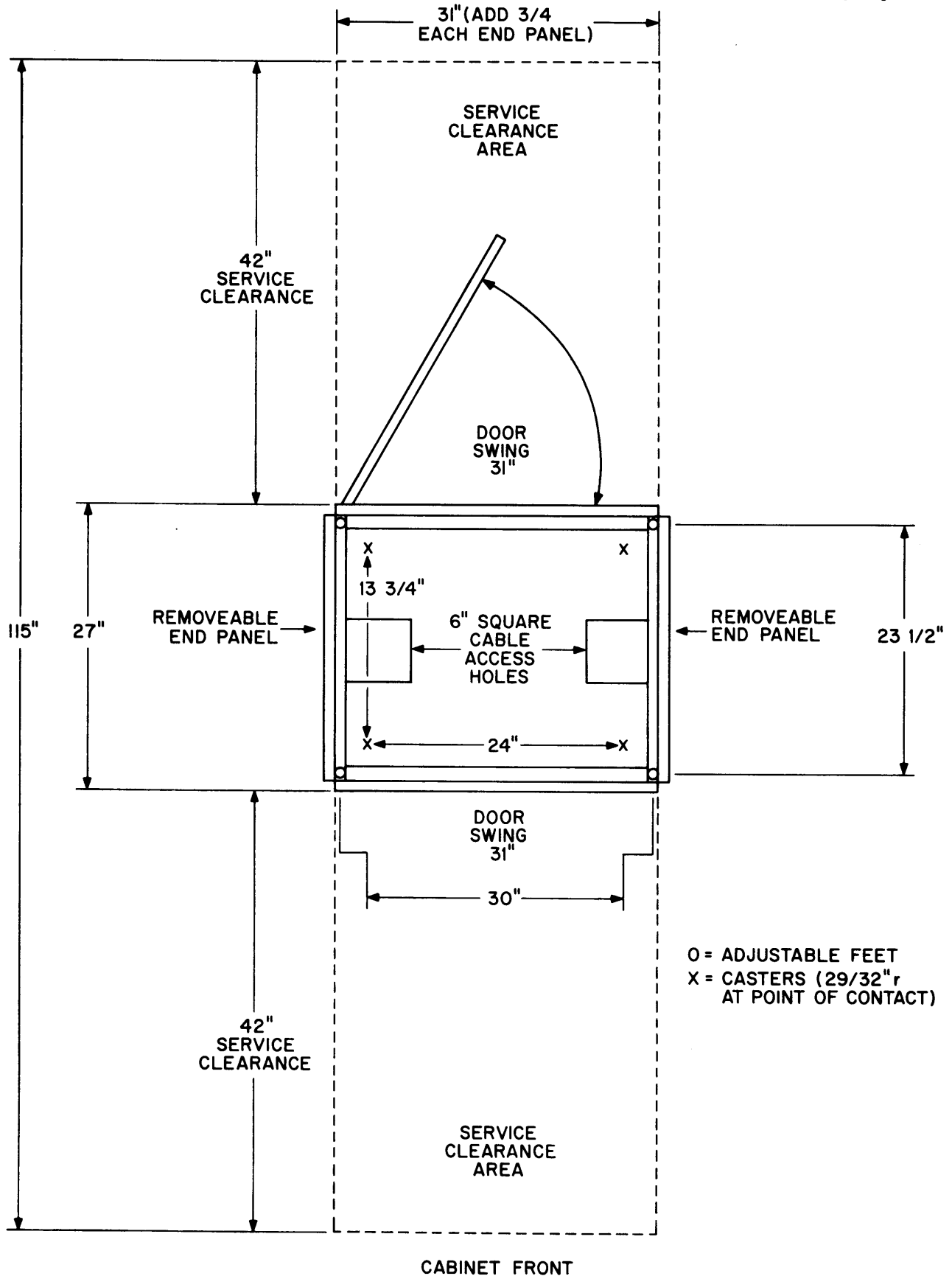

TU79 TAPE TRANSPORT

PDP-10 installation data

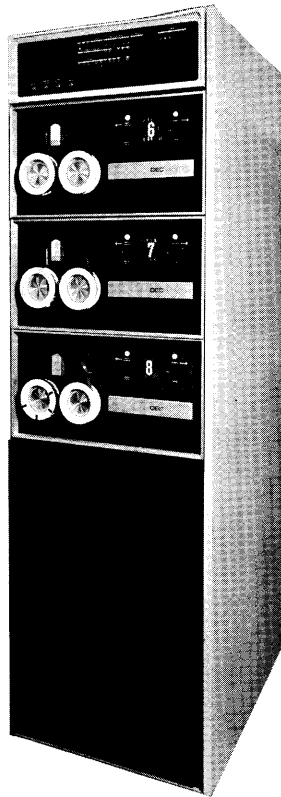

TD10 DECTape CONTROL

Description

TD10A DECTape Control can handle up to eight TU55 DECTape Transports. The control is housed in a 19 in. cabinet which has space for up to three TU55 transports.

If five or less TU55s are used, two are housed in the KA10 Central Processor Console Cabinet, and up to three may be housed in control cabinet TD10A.

If six to eight TU55s are used, then a TD10B 19 in. expander cabinet must be added.

TD10A or TD10A and TD10B must always be bolted to the right end of KA10 Central Processor. These are the only cabinets that may be bolted to the processor.

Physical Specifications

Voltage (AC)	Current (A) Nominal @ 115V	Power Dissipation (W)	Heat Dissipation (Btu/hr)	Dimensions (inches)	Service Clearance (inches)	Weight (lbs)	Operating Temperature (min-max F)	Storage Temperature (min-max F)	Humidity (Rel) (min-max)	Maximum Wet Bulb	Maximum Cable Length
See Note 1 Note 2	2.5	200	682	Height 69 Width 21-1/4 Depth 27	Front 36 Rear 36	500	60° to 95°	40° to 110°	20% to 80%	78°F	15 ft Device Cable

NOTE 1: PDP-10 Systems normally operate from 3-phase (WYE connected), 115v \pm 10%, 60 Hz \pm 2 Hz, or 230v \pm 10%, 50 Hz \pm 2 Hz phase to neutral. This device has a separate power cord using 3-wire 30A (single phase) Hubbel Twistlock Connectors. An earth/ground connection must be supplied through the power cord in addition to the ground bus requirements.

NOTE 2: For use within North America, this device will have a 3-wire Hubbel #3331 (mates with Hubbel #3330) power cord cap (male plug) supplied on the end of a 25-foot cord.

For use outside of North America, this device will have a pressure-type terminal strip suitable for 8 to 18 gauge wire enclosed inside the equipment's power control.

PDP-10 installation data

TU55 DECtape TRANSPORT

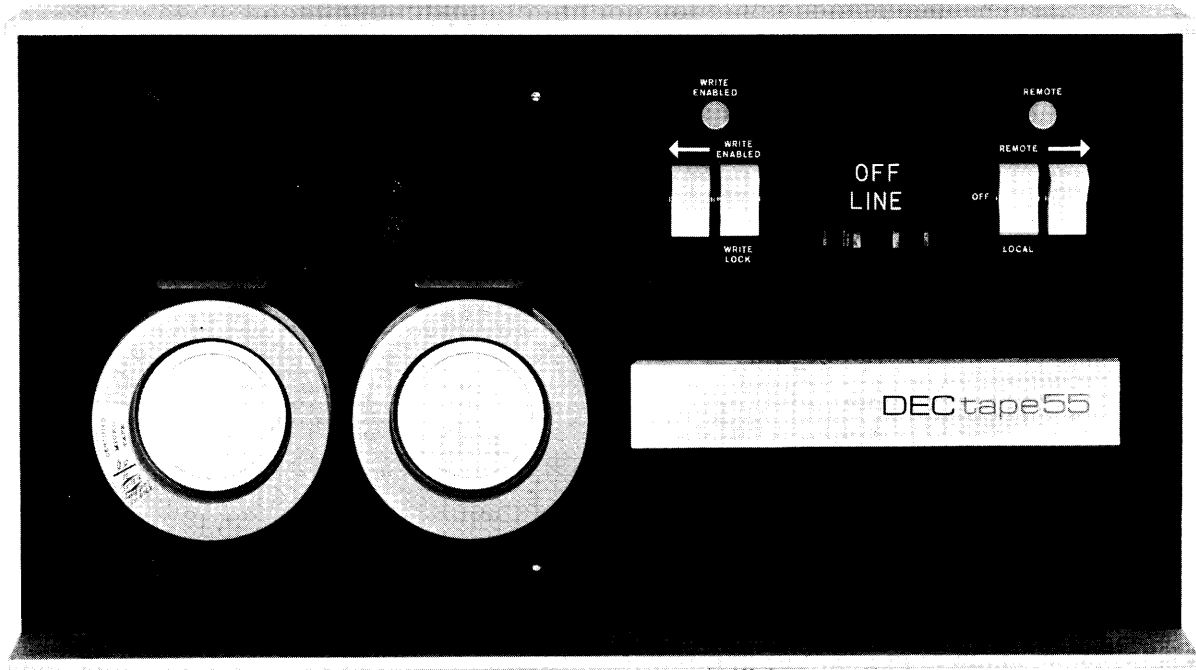

Description

The TU55 DECTape Transport is a fixed-address magnetic tape storage system which provides random access for high-speed reading or writing of files on a 3-1/2 in. diameter, 260 ft reel of tape. Each DECTape reel holds up to 2.7 million bits.

Two TU55s may be housed in the KA10 Central Processor, up to three in TD10A DECTape Control, and up to three in TD10B Expander Cabinet.

Physical Specifications

Voltage (AC)	Current (A) Nominal @ 115V	Power Dissipation (W)	Heat Dissipation (Btu/hr)	Dimensions (inches)	Service Clearance (inches)	Weight (lbs)	Operating Temperature (min-max F)	Storage Temperature (min-max F)	Humidity (Rel) (min-max)	Maximum Wet Bulb	Maximum Cable Length
See Note 1	1	150	510	Height 10-1/2 Width 19 Depth 9-3/4	Front 16-3/4	40	60° to 80°	40° to 110°	40% to 60%	78°F	Up to 15 ft

NOTE 1: PDP-10 Systems normally operate from 3-phase (WYE connected), 115v \pm 10%, 60 Hz \pm 2 Hz, or 230v \pm 10%, 50 Hz \pm 2 Hz phase to neutral. This device has a separate power cord using 3-wire 30A (single phase) Hubbel Twistlock Connectors. An earth/ground connection must be supplied through the power cord in addition to the ground bus requirements.

NOTE 2: For use within North America, this device will have a 3-wire Hubbel #3331 (mates with Hubbel #3330) power cord cap (male plug) supplied on the end of a 25-foot cord.

For use outside of North America, this device will have a pressure-type terminal strip suitable for 8 to 18 gauge wire enclosed inside the equipment's power control.

The descriptions, specifications, and prices contained herein were in effect at the time of approval for printing. Digital Equipment Corporation reserves the right to change descriptions, prices, specifications, or designs without notice and without incurring obligation.

PDP-10 installation data

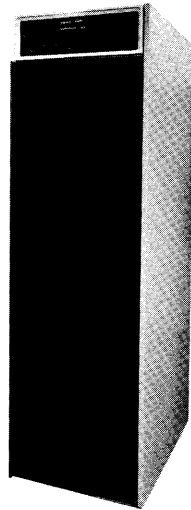

DC10 DATA LINE SCANNER

Description

DC10 Data Line Scanner provides a capability for on-line servicing of up to 64 communication lines. It will accommodate any device which uses 5-level or 8-level serial Teletype code, at speeds up to 100 kilobaud. Full duplex, full duplex with local copy, and half duplex (simplex) data line modes are available on each line serviced. Send-only and receive-only stations can be used. The DC10A Control Unit is the line scanner and central control unit for the DC10 series. It provides cabinet space and power supplies for various combinations of line equipment up to 32 lines maximum (4 line groups). For more than 32-line operation, an additional DC10F Expander Cabinet is required. DC10B 8-line Group Unit provides Teletype interfaces for up to eight local lines, full duplex or Dataphone, and provides for up to three separate

speed lines. It is housed in the DCA and DC10F.

DC10C 8-line Telegraph Relay Assembly provides conversion from local to long lines and has half-duplex facilities. It is housed in the DC10A or DC10F cabinet.

DC10F Telegraph Power Supply is the standard line-voltage power supply used with the DC10C. It is housed in the DC10A or DC10F cabinet.

DC10E Expanded Dataset Control provides expanded control of eight data-sets in the DC10 system, and controls two automatic dialing units (if dial-units are part of system). It is housed in DC10A or DC10F cabinet.

Customer supplies signal cabling from DC10 to teletypes and data sets.

Physical Specifications

Voltage (AC)	Current (A) Nominal @ 115V	Power Dissipation (W)	Heat Dissipation (Btu/hr)	Dimensions (inches)	Service Clearance (inches)	Weight (lbs)	Operating Temperature (min-max F)	Storage Temperature (min-max F)	Humidity (Rel) (min-max)	Maximum Wet Bulb	Maximum Cable Length
See Note 1 Note 2	11	1000	3410	Height 69 Width 21-1/4 Depth 27	Front 36 Rear 36	500	60° to 95°	40° to 110°	20% to 80%	78°F	150 ft (I/O bus)

NOTE 1: PDP-10 Systems normally operate from 3-phase (WYE connected), 115v ± 10%, 60 Hz ± 2 Hz, or 230v ± 10%, 50 Hz ± 2 Hz phase to neutral. This device has a separate power cord using 3-wire 30A (single phase) Hubbel Twistlock Connectors. An earth/ground connection must be supplied through the power cord in addition to the ground bus requirements.

NOTE 2: For use within North America, this device will have a 3-wire Hubbel #3331 (mates with Hubbel #3330) power cord cap (male plug) supplied on the end of a 25-foot cord.

For use outside of North America, this device will have a pressure-type terminal strip suitable for 8 to 18 gauge wire enclosed inside the equipment's power control.

PDP-10 installation data

346/340 CRT DISPLAY



Description

The 346/340 Precision Incremental Display is a system for converting digital data into points, straight lines, and curves at high speed. An optional feature permits the generation of alphanumeric characters. The 340 Display accepts digital data from the computer in the form of vec-

tor, point increment, and control commands. There are 1024 x 1024 scope face locations, in the 9-3/8 in. square display area. A 370 Light Pen option is included. The 346/340 is housed in two 19 in. cabinets which are bolted together.

Physical Specifications

Voltage (AC)	Current (A) Nominal @ 115V	Power Dissipation (W)	Heat Dissipation (Btu/hr)	Dimensions (inches)	Service Clearance (inches)	Weight (lbs)	Operating Temperature (min-max F)	Storage Temperature (min-max F)	Humidity (Rel) (min-max)	Maximum Wet Bulb	Maximum Cable Length
See Note 1 Note 2	15	1730	5900	Height 69 Width 42 Depth 54	Front - Rear 36	700	60° to 95°	40° to 110°	20% to 80%	78°	150 ft (I/O bus)

NOTE 1: PDP-10 Systems normally operate from 3-phase (WYE connected), 115v \pm 10%, 60 Hz \pm 2 Hz, or 230v \pm 10%, 50 Hz \pm 2 Hz phase to neutral. This device has a separate power cord using 3-wire 30A (single phase) Hubbel Twistlock Connectors. An earth/ground connection must be supplied through the power cord in addition to the ground bus requirements.

NOTE 2: For use within North America, this device will have a 3-wire Hubbel #3331 (mates with Hubbel #3330) power cord cap (male plug) supplied on the end of a 25-foot cord.

For use outside of North America, this device will have a pressure-type terminal strip suitable for 8 to 18 gauge wire enclosed inside the equipment's power control.

The descriptions, specifications, and prices contained herein were in effect at the time of approval for printing. Digital Equipment Corporation reserves the right to change descriptions, prices, specifications, or designs without notice and without incurring obligation.

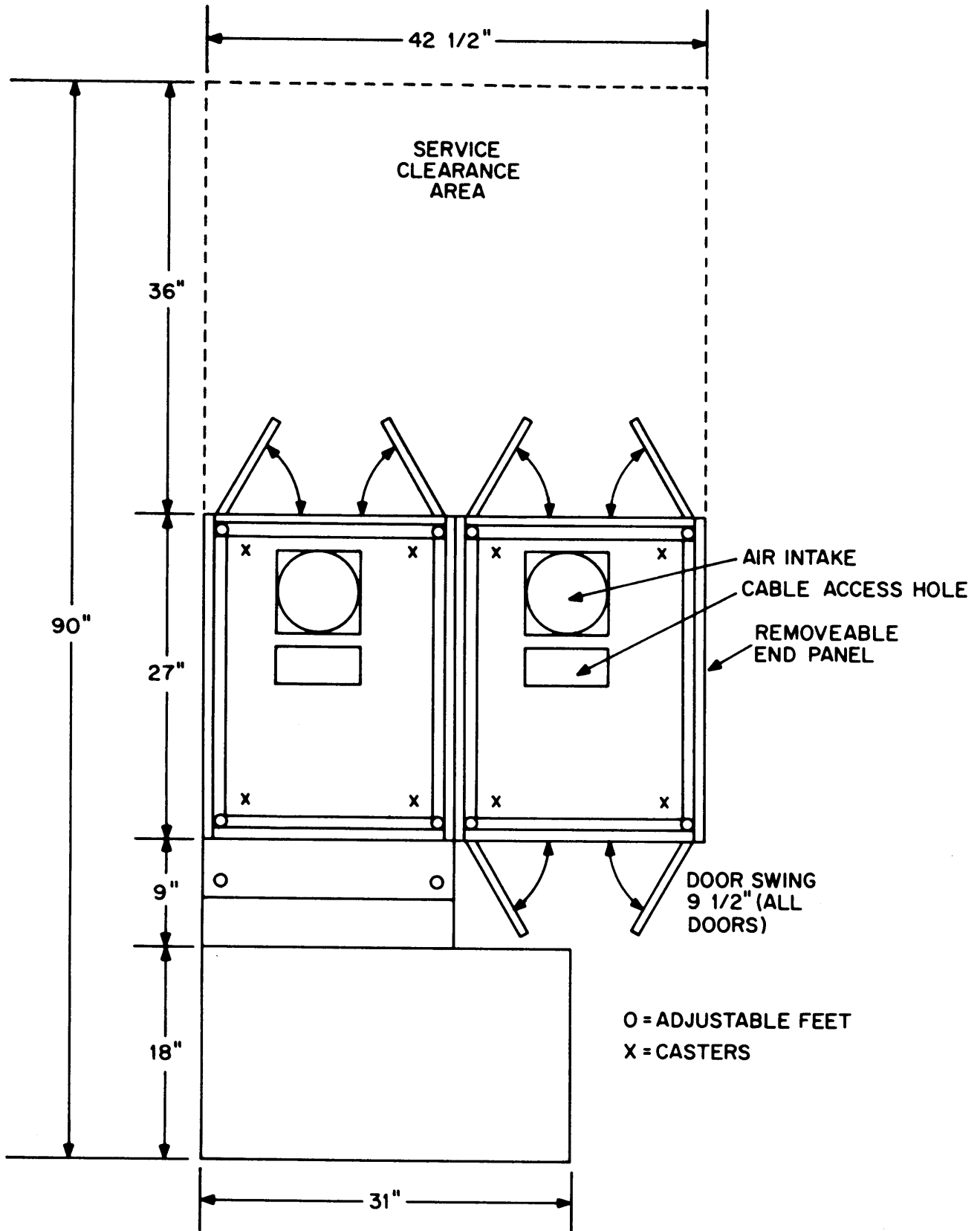

346/340 CRT DISPLAY

PDP-10 installation data

348/VR30

CRT DISPLAY

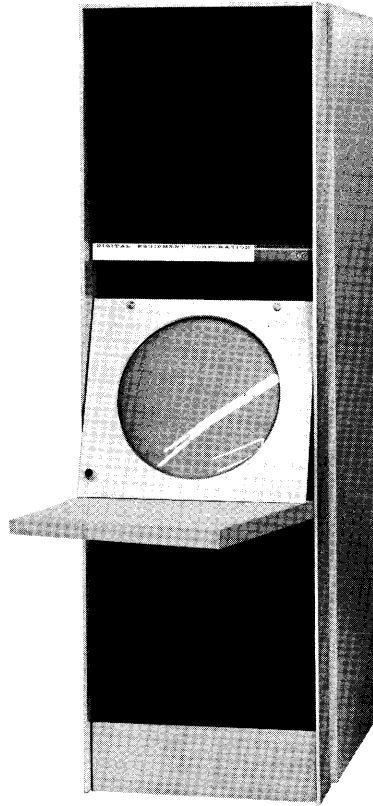

Description

The 348/VR30 Precision Incremental Display is a low-cost, compact point plotting display with the same precision of larger DEC displays. It operates at a maximum plotting rate of 20 kc, or one point every 50 μ s, on a display area 9-3/8 in. x 9-3/8 in.

The number of addressable points along each axis is 1024. A 370 High-Speed Light Pen is included. The 348/VR30 is housed in a 19 in. free-standing cabinet.

Physical Specifications

Voltage (AC)	Current (A) Nominal @ 115V	Power Dissipation (W)	Heat Dissipation (Btu/hr)	Dimensions (inches)	Service Clearance (inches)	Weight (lbs)	Operating Temperature (min-max F)	Storage Temperature (min-max F)	Humidity (Rel) (min-max)	Maximum Wet Bulb	Maximum Cable Length
See Note 1 Note 2	7	805	2750	Height 69 Width 21-1/4 Depth 27	Top 24 Rear 36	360	60° to 95°	40° to 110°	20% to 80%	78°F	150 ft (I/O bus)

NOTE 1: PDP-10 Systems normally operate from 3-phase (WYE connected), 115v \pm 10%, 60 Hz \pm 2 Hz, or 230v \pm 10%, 50 Hz \pm 2 Hz phase to neutral. This device has a separate power cord using 3-wire 30A (single phase) Hubbel Twistlock Connectors. An earth/ground connection must be supplied through the power cord in addition to the ground bus requirements.

NOTE 2: For use within North America, this device will have a 3-wire Hubbel #3331 (mates with Hubbel #3330) power cord cap (male plug) supplied on the end of a 25-foot cord.

For use outside of North America, this device will have a pressure-type terminal strip suitable for 8 to 18 gauge wire enclosed inside the equipment's power control.

PDP-10 installation data

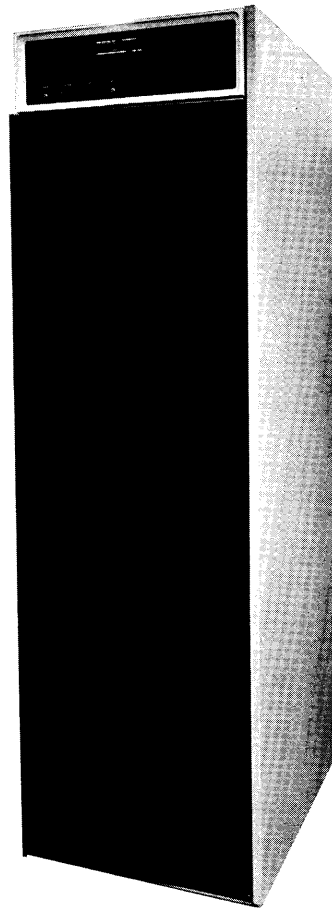

DA10 PDP-8/PDP-9 INTERFACE

Description

DA10 PDP-8/PDP-9 Interface connects either a PDP-8 or PDP-9 computer to the PDP-10 I/O Bus.

Two 36-bit buffers are provided for simultaneous bidirectional transfers.

Physical Specifications

Voltage (AC)	Current (A) Nominal @ 115V	Power Dissipation (W)	Heat Dissipation (Btu/hr)	Dimensions (inches)	Service Clearance (inches)	Weight (lbs)	Operating Temperature (min-max F)	Storage Temperature (min-max F)	Humidity (Rel) (min-max)	Maximum Wet Bulb	Maximum Cable Length
See Note 1 Note 2	2.0	230	800	Height 69 Width 21-1/4 Depth 27	Front 36 Rear 36	300	60° to 95°	40° to 110°	20% to 80%	78°F	20 ft - PDP-8 100 ft - PDP-9 150 ft - PDP-10 (I/O BUS)

NOTE 1: PDP-10 Systems normally operate from 3-phase (WYE connected), 115v \pm 10%, 60 Hz \pm 2 Hz, or 230v \pm 10%, 50 Hz \pm 2 Hz phase to neutral. This device has a separate power cord using 3-wire 30A (single phase) Hubbel Twistlock Connectors. An earth/ground connection must be supplied through the power cord in addition to the ground bus requirements.

NOTE 2: For use within North America, this device will have a 3-wire Hubbel #3331 (mates with Hubbel #3330) power cord cap (male plug) supplied on the end of a 25-foot cord.

For use outside of North America, this device will have a pressure-type terminal strip suitable for 8 to 18 gauge wire enclosed inside the equipment's power control.

TYPICAL PDP-10 SYSTEM LAYOUTS

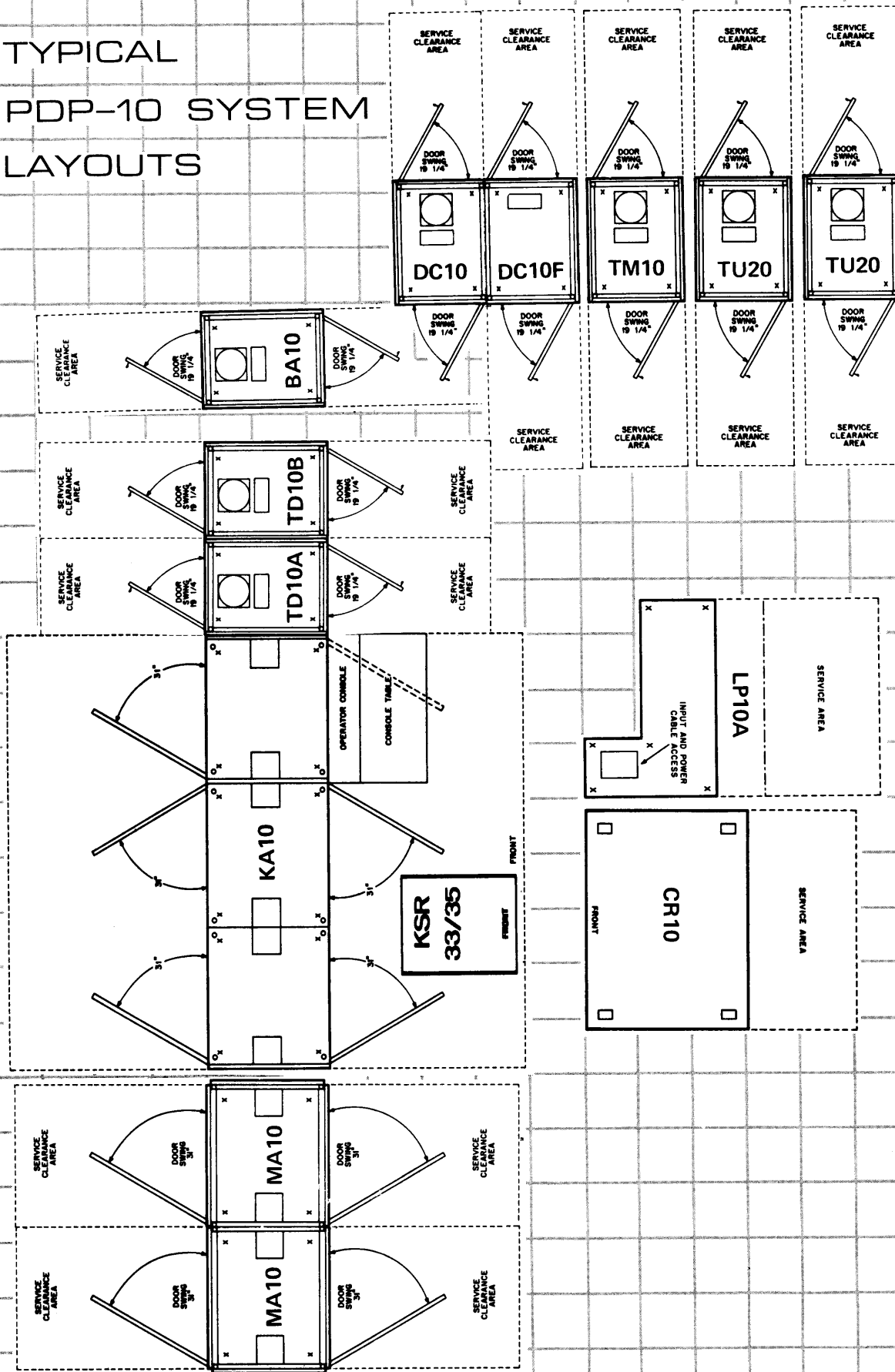

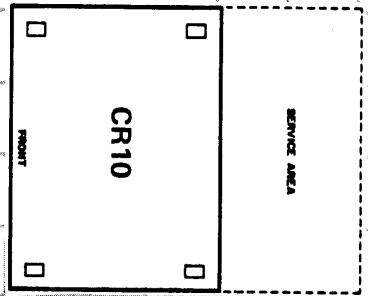
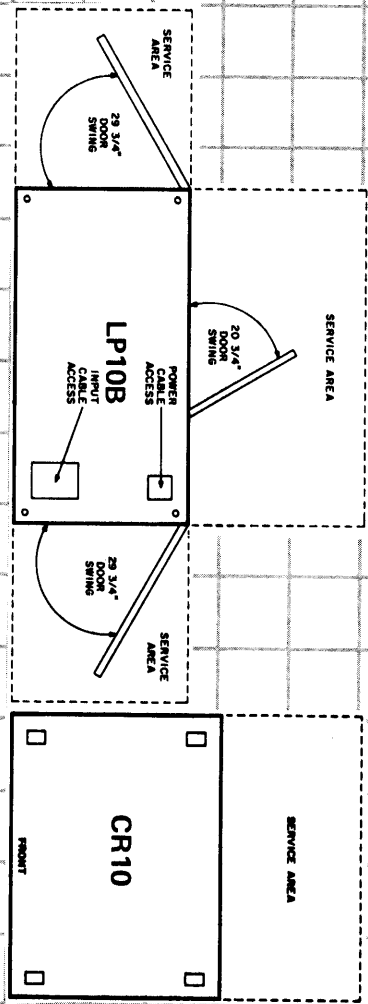
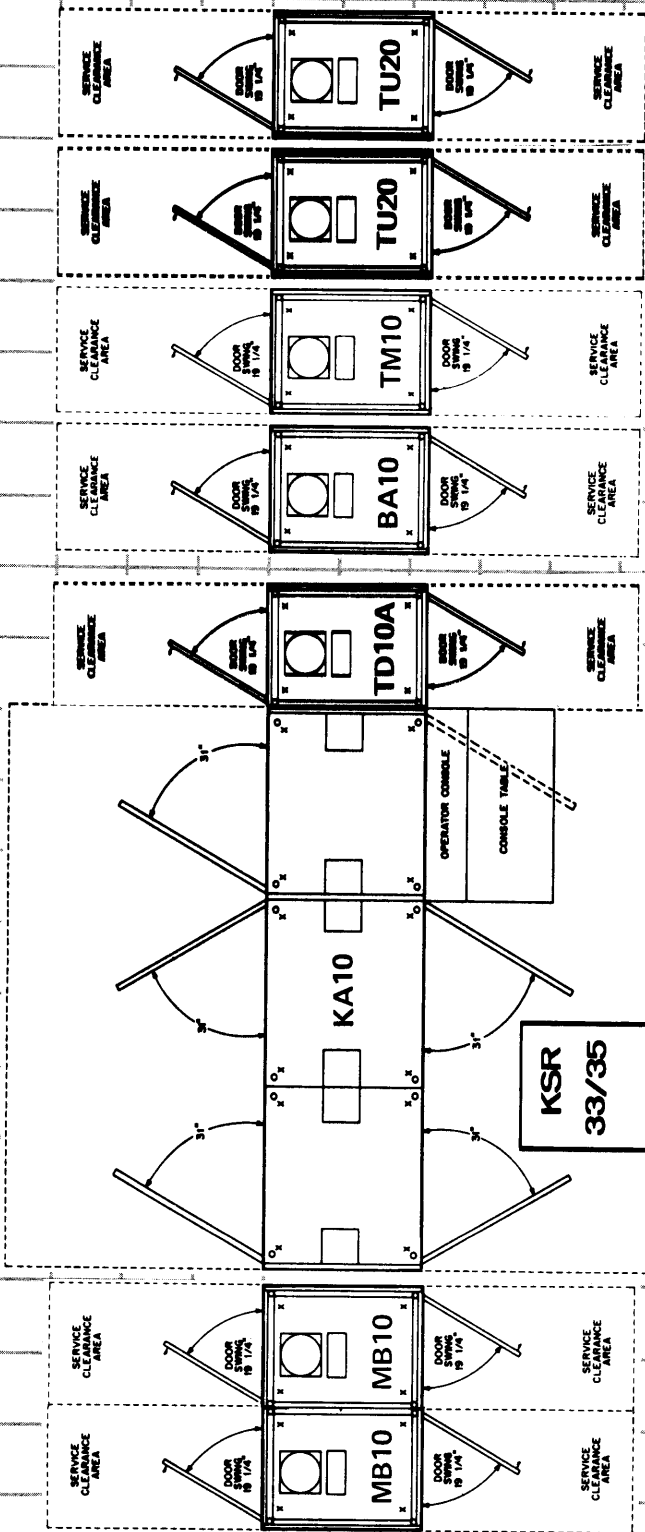

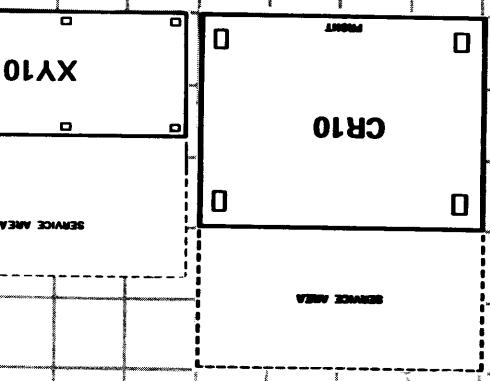
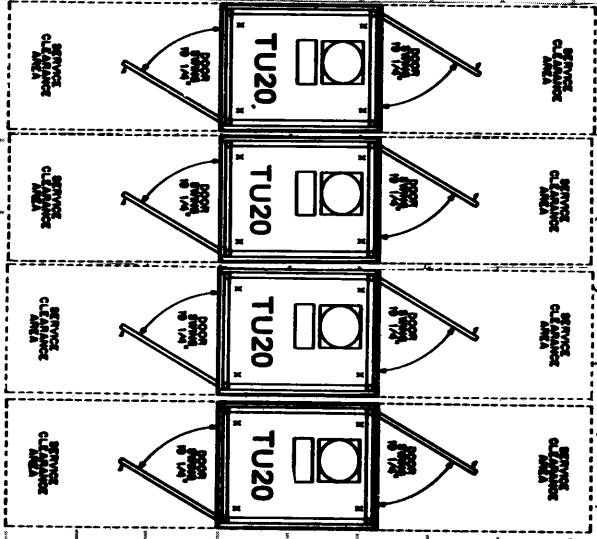
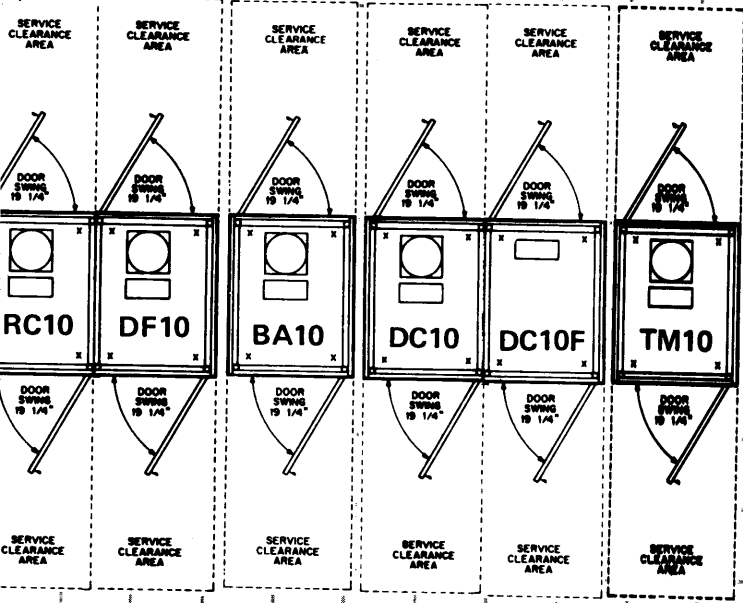
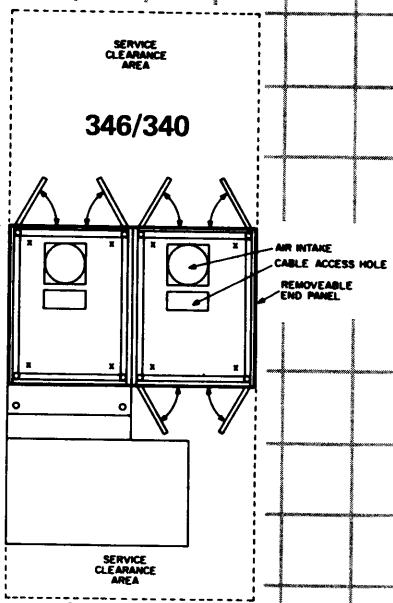
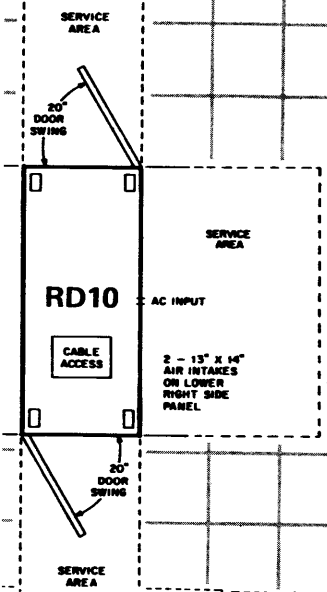

PDP-10 SYSTEM LAYOUT KIT

The layout kit is provided to aid the customer and DIGITAL in planning the most desirable arrangement of system components. The following reminders should be helpful.

Cabinets and Shipping

Unless otherwise requested, the KA10 processor will be shipped as a single 3-cabinet unit, and core memories of like types will be bolted together and shipped as 1, 2, 3, or 4 cabinet units.

If TU55 DECTapes are ordered, a TD10A is bolted to the right side of the KA10 during installation to control up to 5 DECTapes (2 in the KA10 and 3 in the TD10A). Three additional DECTapes may be added in the TD10B which is then bolted to the TD10A. These are the only cabinets bolted to the central processor. All other units are free standing.

Measure carefully door and passageway clearances to insure that all units can be moved into place.

Cables

There are 4 basic cable types, (1) memory bus, (2) I/O bus, (3) device signal, and (4) power.

(1) Memory bus cables originate in the KA10 Processor or in the DF10 Data Channel. Facing the processor, it is important to locate core memory to the left to minimize cable lengths. The Data Channel is normally located near the device control using the channel. In cases where discs are used the channel cabinet is bolted to the disc control. The total length of the memory bus must not exceed 100 feet.

(2) The I/O bus originates in the KA10 processor and daisy chains from one device to the next. I/O devices are normally located to the right of the processor. The total length of the I/O bus is limited to 150 feet.

(3) Device Signal Cables connect controls to devices. The location of the devices is not critical if cable lengths are held to those specified in the data sheets. Devices are normally located for user convenience providing the maintenance panels are visible from the operator's console.

(4) Power Cables may be connected under the floor or from wall outlets located behind the system components. Refer to each data sheet to determine the proper power sources, connectors, ratings, etc.

Controls

A list of required device controls appears below as a quick reference planning guide. More detailed information is supplied on the specification sheets.

<u>Device</u>	<u>Required Control</u>
RD10 Disc File	RC10 Disc/Sync Adaptor
CR10 Card Reader LP10 Line Printers XY10 Plotters	BA10 Combined Control
TU20 Tape Transport TU79 Tape Transport	TM10 Tape Control
TU55 DECTape Transport	TD10 DECTape Control
Communication Lines	DC10 Data Line Scanner
346/340 Display 348/VR30 Display	None
680 Data Communications System	DA10 PDP-8/PDP-9 Interface

USING THE LAYOUT KIT

1. Measure out the proposed area on the fold-out grid. Each 3/8 in. block represents one square foot.
2. Cut out proposed units without removing backing.
3. Roughly position units with backing, remembering generally to keep memories to the left and I/O devices to the right of the KA10. Also, for ease of maintenance, position units so that all indicator or maintenance panels are visible from the operator console.
4. Remove backing and position units. The sticky backing is non-permanent so the units may be pulled up and moved. However, this should be minimized to retain the backing's bonding qualities.
5. Call or write any DIGITAL sales office listed on the back cover for additional Layout Kits.