

# RV20 Optical Disk Subsystem

Owner's Manual

Prepared by Educational Services  
of Digital Equipment Corporation

1st Edition, January, 1988

2nd Edition, June, 1988

Copyright © 1988 by Digital Equipment Corporation.

All Rights Reserved.

Printed in U.S.A.

The reproduction of this material, in part or whole, is strictly prohibited. For copy information, contact the Educational Services Department, Digital Equipment Corporation, Maynard, Massachusetts 01754.

The information in this document is subject to change without notice. Digital Equipment Corporation assumes no responsibility for any errors that may appear in this document.

#### CAUTION

Use of controls and adjustments or performance of procedures other than those specified herein may result in hazardous radiation exposure.

**CLASS 1  
LASER PRODUCT**

**DANGER**  
INVISIBLE LASER RADIATION WHEN OPEN.  
AVOID DIRECT EXPOSURE TO BEAM.

**LEGAL NOTICE:** TMSCP and STI protocols and documentation are the proprietary information of Digital Equipment Corporation. UNIBUS, Q-BUS/BI-BUS port drivers and documentation for MSCP/TMSCP products are also proprietary information of Digital Equipment Corporation.

**NOTICE:** This equipment generates and uses radio frequency energy. It has been type tested and found to comply with the limits for a Class B computing device in accordance with the specifications in Subpart J of Part 15 of FCC Rules, which are designed to provide reasonable protection against radio and television interference in a residential installation. However, there is no guarantee that interference will not occur in a particular installation. If this equipment does cause interference to radio or television reception, the user is encouraged to try to correct the interference.

The following are trademarks of Digital Equipment Corporation, Maynard, Massachusetts.

**DEC**

DEC

DECmate

DFCnet

DECsystem-10

DFCSYSTEM-20

DECUS

DECwriter

DIBOI

MASBUS

PDP

P/OS

Professional

Q-Bus

Rainbow

RSIS

RSX

RT

UNIBUS

VAX

VAXstation

VMS

VT

Work Processor

# Contents

---

## Preface

vii

---

## Chapter 1 Overview

---

1.1	Product Description	1-1
1.2	Subsystem Overview	1-2
1.3	Environmental/Safety Requirements	1-4
1.4	Related Documentation	1-5
1.5	Specifications	1-5
1.5.1	Physical	1-5
1.5.2	Environmental	1-5
1.5.3	Electrical	1-6
1.5.4	Media	1-6

## Chapter 2 Software

---

2.1	Overview	2-1
2.2	The RV20 as a Tape Device	2-1
2.3	Everyday Use of the RV20	2-2
2.3.1	Applications	2-2
2.3.2	Initializing	2-2
2.3.3	Encountering the End of a Volume	2-3
2.3.4	Encountering Bad Sectors	2-3
2.4	File Maintenance	2-4

2.4.1	Files with Multiple Versions . . . . .	2-4
2.4.2	Volumes with Multiple Savesets . . . . .	2-4
2.4.3	Overwriting Files . . . . .	2-4
2.4.4	Keeping Directories on Other Media . . . . .	2-6
2.5	Improving RV20 Performance . . . . .	2-6
2.5.1	Cataloging File Positions . . . . .	2-6
2.5.2	Positioning the RV20 to True LEOI . . . . .	2-7
2.5.3	Rewind Operations . . . . .	2-7
2.5.4	Optimizing Transfer Rates . . . . .	2-7

## Chapter 3 Operation

---

3.1	Overview . . . . .	3-1
3.2	RV20 Front Panel . . . . .	3-2
3.3	Power-Up . . . . .	3-5
3.4	RV20 Media . . . . .	3-5
3.5	Write Protecting a Disk . . . . .	3-6
3.6	Loading/Spinning Up a Disk . . . . .	3-8
3.7	Host Initiated Spin-Up/Spin-Down . . . . .	3-8
3.8	Spinning Down/Unloading a Disk . . . . .	3-8

## Chapter 4 Maintenance and Problem Solving

---

4.1	Filter Replacement/Cleaning . . . . .	4-1
4.2	Cartridge Replacement/Disk Cleaning . . . . .	4-3
4.3	Problem Solving . . . . .	4-6
4.4	Digital Repair Services . . . . .	4-7

## Figures

---

1-1	RV20 Subsystem . . . . .	1-2
1-2	RV20 Subsystem Block Diagram . . . . .	1-3
3-1	RV20 Front Panel . . . . .	3-2
3-2	RV20 Disk Cartridge . . . . .	3-5
3-3	Write Protecting a Disk . . . . .	3-7
3-4	Loading a Disk . . . . .	3-9

4-1	Filter Removal . . . . .	4-2
4-2	Disk Cartridge Parts . . . . .	4-3
4-3	Disengaging the Cartridge Parts . . . . .	4-4
4-4	Separating the Cartridge Parts . . . . .	4-5

## Tables

---

1-1	Related Documentation . . . . .	1-5
2-1	Optimal Block Sizes . . . . .	2-8
3-1	RV20 Operator Panel . . . . .	3-4
4-1	Problem Solving . . . . .	4-6



# Preface

---

## HOW TO USE THIS MANUAL

This manual is intended for the everyday user of the RV20 optical disk drive subsystem. The subsystem consists of up to four RV20 optical (File #) disk drives. The operation of the drive is the same no matter how many drives are in any particular subsystem.

**Chapter 1 - Overview** - This chapter gives a basic description of the RV20 optical disk drive and the RV20 subsystem. It also lists the specifications of the drive and the related documentation available from Digital Equipment Corporation.

**Chapter 2 - Software** - This chapter contains software information. It is intended as a reference for RV20 subsystem users.

**Chapter 3 - Operating** - This chapter gives instructions on how to operate the RV20 disk drive. The controls and indicators, as well as loading and unloading procedures, are all described and illustrated.

**Chapter 4 - Maintenance** - This chapter describes the scheduled maintenance the user has to perform to keep the RV20 in good working order. It also gives instructions for repairing a damaged disk cartridge and for cleaning a disk. This chapter lists some basic problems that may be encountered during normal use of the RV20 and some corrective steps that can be taken before calling Digital Field Service. This chapter then describes the various repair services offered by Digital.



# Chapter 1

---

## Overview

### 1.1 Product Description

The RV20 optical disk drive is a random access, mass storage device that uses a laser beam to write and read data. The RV20 is capable of writing data onto a disk area once, and can read data off the disk an unlimited number of times.

The data is stored on 12-inch removable optical disks. There are 32,000 tracks on each disk surface. Each surface can store 1 gigabyte (about 1 billion characters) of information.

The optical disk is contained in a cartridge that loads into the drive. When the cartridge is loaded, access doors open allowing a laser beam to read and write. The optical disk inside the cartridge is a glass sandwich disk. The sandwich consists of the glass separated by spacers, a polymer intermediate layer, and a sensitive tellurium layer.

To write data, the RV20 uses a laser light beam to burn microscopic holes ("pits") into the tellurium layer on the disk. To read data, the RV20 shines a less powerful beam on the disk. This less powerful beam reflects light off the disk and photodetectors measure the amount of reflected light.

If the light shines onto the disk where there is no pit (a "flat"), most of the light is reflected back and measured by the photodetectors. This condition is a binary zero. If the light shines into a pit, less light is reflected back to the photodetectors. This condition is a binary one.

## 1.2 Subsystem Overview

The RV20 subsystem consists of up to four RV20 optical disk drives contained in a single cabinet. One RV20 drive serves as the "master" drive in the subsystem. The other RV20s in the subsystem are "slave" devices, connected to the master. Note that slave drives are not necessary in a subsystem. A complete RV20 subsystem can consist of simply one RV20 master drive.

The RV20 master drive contains a drive subsystem controller module. The drive subsystem controller module formats the data from all the subsystem drives in accordance with the requirements of the host computer.

Figure 1-1 shows a cabinet with four RV20s installed in it. A number of configurations are possible, ranging from one RV20 subsystem (one master drive with three slaves) to four separate RV20 subsystems (four RV20 master drives).

An RA- series disk drive may also be included in the RV20 cabinet. This disk drive is independent of the RV20 subsystem. Consult the RA- series disk drive documentation for operating information.

Figure 1-1: RV20 Subsystem

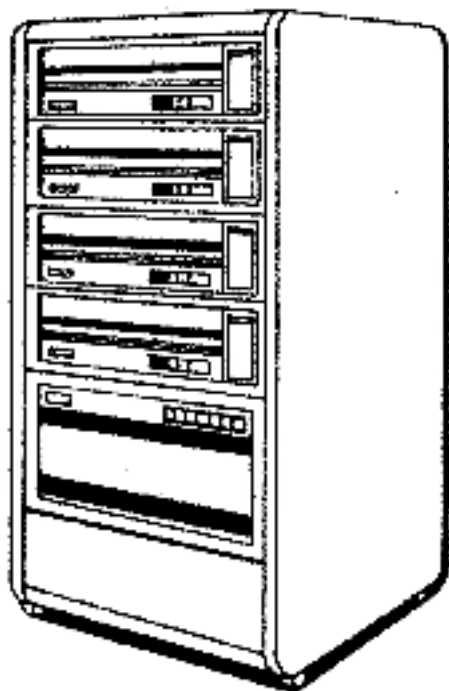
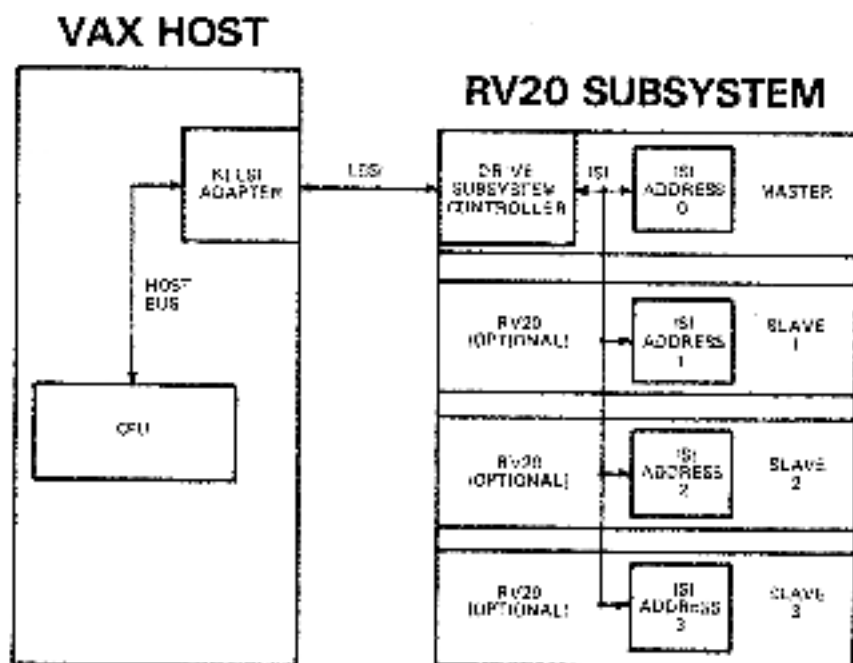

Figure 1-2 is a block diagram of an RV20 subsystem consisting of a master RV20 and three slaves. The RV20 uses its own internal bus, known as the ISI bus. Each RV20 drive in a subsystem has an ISI address from 0 to 3. The drive subsystem controller module in the master RV20 translates the ISI data into the format required by the LESI (Low-End Storage Interconnect) interface. The LESI bus is the path to the VAX host. The host uses its own internal bus. The RV20 data travels on the LESI to the host, where it enters a KLESI adapter module. The adapter converts the LESI-formatted data into the host bus format, where the data can then be processed.

Figure 1-2: RV20 Subsystem Block Diagram



311-02001

## 1.3 Environmental/Safety Requirements

The RV20 subsystem can operate in a computer room, office, or light industrial environment. A good rule of thumb concerning the operating environment is to follow the environmental requirements of the host computer system.

The RV20 optical disk drive contains a Class 1 laser system. A Class 1 laser is a low-powered laser and poses very little potential harm to users. Nevertheless, some precautions and guidelines should be followed to ensure safety. The outer shell of the drive contains shielding that protects the user from any harmful laser radiation. Never remove the covers of the drive to expose the internal parts. Exposing the inner parts of the drive will not only eliminate the laser protection in the drive, but may also damage the drive and void the warranty.

As well as laser safety, there are other safety considerations you should undertake to protect yourself and the RV20 disk drive.

- Never put your hand inside the cartridge door opening. The drive has moving parts and physical injury could result. The internal parts of the RV20 are extremely static sensitive and serious drive damage can also result from contact with a nongrounded source.
- Always keep the cartridge door closed when not in use.
- Never put a damaged cartridge inside the drive. Refer to Chapter 4 for replacement instructions.
- Never force the cartridge door open. The door should open and close freely. Refer to Chapter 4 if you are having trouble.
- Never force a cartridge in or out of the drive.
- Make sure a clean air filter is always installed in the drive. Refer to Chapter 4.

## 1.4 Related Documentation

Table 1-1 lists the RV20 documentation available from Digital Equipment Corporation.

**Table 1-1: Related Documentation**

Document	Part Number	Description
RV20 Optical Disk Subsystem Installation Guide	FX-ORV20-IN	Contains installation information for the Digital Field Service engineer installing the subsystem. This manual also lists all the diagnostics needed to verify that the subsystem has been installed properly and is in good working order.
RV20 Optical Disk Subsystem Service Guide	FK-ORV20-SV	Contains service information on the RV20 subsystem for use by field engineers. This information includes instructions on how to run diagnostics to isolate a problem to a Field Replaceable Unit (FRU). This guide contains removal and replacement procedures for all FRUs.

## 1.5 Specifications

The following are the specifications of the RV20 optical disk drive.

### 1.5.1 Physical

Width:	48.3 cm (19.0 in)
Height:	13.0 cm (5.125 in)
Depth:	65.0 cm (25.6 in)
Weight:	25.0 kg (55.0 lb)

### 1.5.2 Environmental

	Operating	Non-Operating
Ambient Temperature	10 to 40°C 50 to 104°F	-40 to 66°C -40 to 151°F
Relative Humidity	10 to 90%	10 to 95%
Maximum Wet Bulb (non-condensing)	28°C (82°F)	46°C (115°F)

### 1.5.3 Electrical

#### Regulated Power Supply Voltages:

+12 Vdc	0.2 to 3.9 A
-12 Vdc	0.2 to 3.5 A
+5 Vdc	2 to 21 A
-5 Vdc	0.1 to 1.0 A
+24 Vdc	0.1 to 3.0 A
+90 Vdc	0.01 A

#### Power Consumption

Average:	175 W
Worst Case:	250 W

**Power Supply:** Auto ranging, no mechanical switching

Low Range: 86.7 to 128 Vac @ 47 to 63 Hz

High Range: 173.4 to 268 Vac @ 47 to 63 Hz

### 1.5.4 Media

Disk Storage Capacity:	1 gigabyte per side
Disk Construction:	glass with pregrooved metallic layer
Disk Diameter:	306 mm (12 in)
Data Surfaces:	2

#### Recording

Tracks per Disk:	32,000
Sector Size:	1,024 user bytes (data bytes)
Sectors per Track:	32

## Chapter 2

---

### Software

#### 2.1 Overview

This chapter contains some software information that you may find helpful in your everyday use of the RV20. This is not a programming chapter. We recommend that you consult your system manager or refer to the host system documentation for more information. The following sources are very useful.

- The latest VMS Release Notes, RV20-specific information
- *Guide to VAX/VMS Disk and Magnetic Tape Operations*
- *VAX/VMS I/O User's Reference Manual*
- *VAX/VMS Run-Time Library Routines Reference Manual*

#### 2.2 The RV20 as a Tape Device

The RV20 optical disk drive is a unique product that combines some of the advantages (and disadvantages) of both disk drives and tape drives.

The RV20 is a disk drive, and optical disks are the media on which the RV20 writes and reads data. The host operating system, however, "sees" the RV20 as a tape device. This is why the subsystem is an MU device (for example, MUA0, MUB1) on the system.

The write once feature of the RV20 makes it perform more like a tape device than a disk drive. All write operations are done sequentially, just like with magnetic tapes.

When working with the RV20 under VMS, use commands that are used for tapes, not disks. Refer to your system documentation or consult your system manager.

#### NOTE

Treat data on RV20 media the same way you treat data on a tape. Overwritten data on RV20 media is unrecoverable.

## 2.3 Everyday Use of the RV20

### 2.3.1 Applications

Common tape applications such as MOUNTs, DISMOUNTs, BACKUPs, and COPYs are performed on the RV20 the same way as on magnetic tape drives. You can also use common QIO commands such as IO\$, SKIP, IO\$\_READ, and IO\$\_WRITE (with one of the arguments VBLK, PBLK, or LBLK) just as with tapes.

Since the RV20 is a disk drive, switches such as density have no effect on RV20 data. If you attempt to modify the density, a status message prints out, explaining that the RV20 is not a density switchable device.

Another very important restriction with the RV20 is that you must keep the same format throughout an entire volume. For example, a *foreign* volume must always be mounted as *foreign*.

### 2.3.2 Initializing

As with tapes, when you initialize an RV20 disk, you begin operations from BOT. The difference with the RV20 is that BOT is at a new location after an INIT. The RV20 is a write-once device, so the new BOT will be written where the last data on the media ended.

After an RV20 disk has been re-initialized, subsequent write operations begin on the disk area immediately following the previous data. With a tape, you write over the previous data. It is very important to remember that in both cases, the overwritten data is unrecoverable.

After an INIT on an RV20, the RV20 disk appears to be empty and all previous data is retired. This leaves less disk space available. Every time you initialize with write-once media, you lose disk space.

### 2.3.3 Encountering the End of a Volume

When the RV20 is doing a read or write operation and the end of a disk side is encountered, you are prompted to mount a new volume. When the new volume is mounted, the operation can continue.

For read operations, you must use the `REPLY(TO)=IDENTIFICATION-NUMBER` command after mounting the new volume to continue the operation.

For write operations, you must use a `REPLY` switch command after mounting the new volume to continue the operation. The switches are as follows:

<code>REPLY/INITIALIZE,TAPE= identification_number</code>	must be used for a previously initialized disk
<code>REPLY.BLANK_TAPE= identification_number</code>	must be used for a disk that has never been initialized

#### CAUTION

Failure to use the correct switch qualifier with the `REPLY` command can cause inadvertent initialization of a volume or subsystem hang.

### 2.3.4 Encountering Bad Sectors

In any disk drive, bad sectors can be encountered. The RV20 is not different. When you are writing and the drive encounters what is perceived to be a bad sector, the drive attempts to write in the next sector on the disk. If bad sectors are encountered in sequence, five attempts are made. When, after five attempts, a write cannot be performed, the message "unable to write" is displayed.

The RV20 error log report contains more detailed information on the "unable to write" status. Accessing error logs is beyond the scope of this book. Consult your system manager or refer to the host system documentation for more information on error logs.

RV20 media degradation is detected during read operations. Once again, the error logs contain more detailed information about media degradation.

## 2.4 File Maintenance

### 2.4.1 Files with Multiple Versions

Like tape drives, RV20 optical disk drives do not track version updates of files. If multiple versions of files exist on RV20 media and you want to read a specific file, you must specify the version number. Otherwise, you will get the version that is closest to the "current position." It is important to remember that if you do not specify the version number, you will **not** automatically get the most recent version of the file. You will get the first file of that name encountered during the seek for that filename.

### 2.4.2 Volumes with Multiple Savesets

We recommend the customer never create multiple savesets with the same name on RV20 optical disks. Even though BACKUP permits multiple savesets with the same filename on a tape, and the rogtape ACP does not prevent multiple files with the same name on the tape, problems will occur when you try to COPY files to the device.

### 2.4.3 Overwriting Files

The operating system sees the files on tapes (and on RV20 disks) as a series of objects, starting at the Beginning-Of-Tape (BOT) mark.



Because the RV20 is a write-once device, the data cannot physically be removed; it can only be replaced in the next available space on the media. The RV20 logically overwrites the file with the use of a "pointer." The pointer prevents access to the old file by pointing to the location of the new (updated) file.

Here is an example of this operation.

1. You want to replace (overwrite) File 2. The current position is moved to the start of File 2.

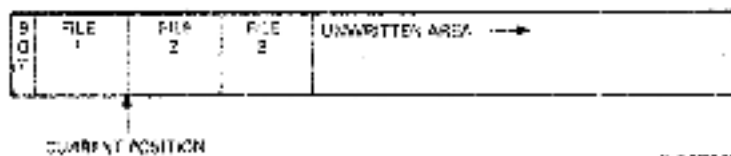

2. A pointer is placed at the start of File 2, pointing to the beginning of the unwritten area on the disk.

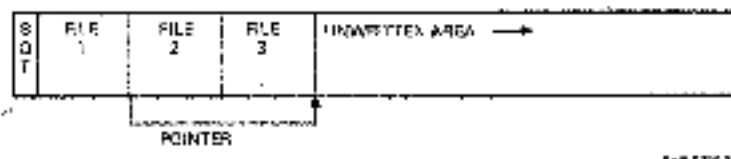

3. The current position is moved to the beginning of the unwritten area on the disk.
4. A new file (File 4) is written at the start of the unwritten area. This new file is the update of File 2.

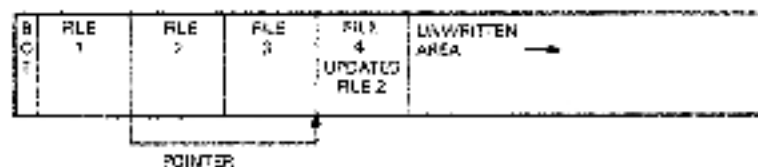

After this is accomplished, File 2 can never be accessed again, even though it still exists on the disk. Whenever an attempt is made to read File 2, the pointer will point to File 4 and File 4 will be read.

## 2.4.4 Keeping Directories on Other Media

It is common practice to keep a directory of an optical disk on magnetic media. If the RV20 directory residing on magnetic media is lost or destroyed, you can reconstruct it by skipping and reading each file on the RV20 disk. An `IOS SKIP` command can accomplish this. The result of this command is a directory of the files on the optical disk and their locations (the first file, the second file, and so on). Programs can be written to perform this directory maintenance in any VMS-supported language.

## 2.5 Improving RV20 Performance

### 2.5.1 Cataloging File Positions

When locating a file on a VAX/VMS ANSI-labeled tape, a tape drive normally does a series of sequential read operations. Successive file header labels are transferred to the host until the desired file is found. It is a time-consuming operation that grows worse as more files are added to the tape.

A significant RV20 performance advantage can be obtained by writing a host application program that catalogs file positions relative to tape mark numbers. If the index file has not been fragmented by previous user data overwrites, you can write an application program that uses the VAX/VMS queue I/O services in conjunction with the magnetic tape driver to make effective use of the RV20's random addressability.

For example, consider RV20 media on which files have been written according to the VAX/VMS ANSI-labeled format. There are three tape marks associated with each file on the volume. An `IOS_SKIPFILE` logical QIO command with the tape mark count equal to six positions the RV20 at the header label of the third file on the media.

Accessing files in this way, rather than sequentially reading the volume, significantly reduces RV20 file access times.

## 2.5.2 Positioning the RV20 to True LEOT

Positioning the RV20 to the true Logical End-Of-Tape (LEOT) prior to writing a new file is another method of improving RV20 performance. If only one LEOT (double tape mark) exists on the media, the RV20 is able to seek the end of the user data area during a detect LEOT operation. If the media has multiple LEOTs due to user programming, finding the true LEOT is a much lengthier procedure.

## 2.5.3 Rewind Operations

Rewind operations on the RV20 are also efficient. An `IO$_REWIND` command results in a direct seek to the beginning of the user data area.

## 2.5.4 Optimizing Transfer Rates

The RV20 has 100 Error Correction Code (ECC) bytes appended to each sector of user data, so data integrity is independent of block size. The data integrity of magnetic tape drives is sacrificed when large block sizes are used. This is not the case with the RV20. Data structures are maintained on the RV20 disk for every block of user data received from the host. Transfer rates can, therefore, be optimized by mounting an RV20 volume with the largest practical VMS block size. Table 2-1 lists the optimal block sizes for 1 to 64 sectors.

For a given record, the RV20 controller adds the following sector descriptor data bytes.

- 36 bytes to the first sector
- 10 bytes to each succeeding sector

Consider a file of 8192 bytes (8K). If the block size is 2048, the file comes over from the host in four block transfers. Each of the four block transfers is written as follows.

- The first sector is filled with 36 sector descriptor bytes, followed by 988 bytes of the file. (A sector is 1024 bytes long.)
- The second sector contains 10 sector descriptor bytes, followed by 1014 data bytes.
- The third sector contains 10 sector descriptor bytes, followed by the remaining 46 data bytes of the 2048-byte block of file data. The remaining 968 bytes in the third sector are wasted bytes.

When the file transfers to the disk, it occupies 12 sectors, and every third sector has 968 unused bytes. Not only is the transfer rate for this file long, but it also represents an incredible amount of wasted disk space.

The alternative is to transfer the 8192-byte file using a large block size. An 8K file occupies 8 sectors on the disk. You know that 36 bytes will be added to the first sector and 10 to each additional sector, so the file will occupy at least 9 sectors.

Use Table 2-1 to find the optimal block size for 9 sectors. With a block size of 9100, the single-block transfer occupies the disk as follows.

- The first sector is filled with 36 sector descriptor bytes, followed by 988 bytes of the file.
- The second through eighth sectors each contain 10 sector descriptor bytes, followed by 1014 data bytes.
- The ninth sector contains 10 sector descriptor bytes, followed by 106 data bytes. The remaining 908 bytes in the ninth sector are wasted bytes.

Note that using the optimal block size increases the transfer rate and saves disk space (only 9 sectors are used instead of 12).

**Table 2-1: Optimal Block Sizes**

Number of Sectors	Optimal Block Size	Number of Sectors	Optimal Block Size
1	988	31	33436
2	2000	34	34448
3	3016	35	35464
4	4028	36	36476
5	5044	37	37492
6	6056	38	38504
7	7072	39	39520
8	8084	40	40532

**Table 2-1 (Cont.): Optimal Block Sizes**

Number of Sectors	Optimal Block Size	Number of Sectors	Optimal Block Size
9	9100	41	41548
10	10112	42	42560
11	11128	43	43576
12	12140	44	44588
13	13156	45	45604
14	14168	46	46616
15	15184	47	47632
16	16196	48	48644
17	17212	49	49660
18	18224	50	50672
19	19240	51	51688
20	20252	52	52700
21	21268	53	53716
22	22280	54	54728
23	23296	55	55744
24	24308	56	56756
25	25324	57	57772
26	26336	58	58784
27	27352	59	59800
28	28364	60	60812

**Table 2-1 (Cont.): Optimal Block Sizes**

<b>Number of Sectors</b>	<b>Optimal Block Size</b>	<b>Number of Sectors</b>	<b>Optimal Block Size</b>
29	29380	61	61828
30	30392	62	62840
31	31408	63	63856
32	32420	64	64868

## Chapter 3

---

# Operation

### 3.1 Overview

This chapter describes and illustrates the RV20 drive and the steps necessary to operate the drive. The first section of this chapter illustrates and explains the controls, indicators, and displays on the RV20 front panel.

The rest of the chapter illustrates and explains how to perform basic operations on the RV20. It is set up in the following logical sequence of operation.

- How to power up the drive
- How to write-protect a disk
- How to load a disk into the RV20 drive
- How to spin a disk up
- How to spin a disk down
- How to unload a disk from the RV20 drive

## 3.2 RV20 Front Panel

Figure 3-1 shows the front panel of the RV20. The following section explains each item on the front panel. Table 3-7 describes each switch, indicator, and display on the operator panel.

Figure 3-1: RV20 Front Panel

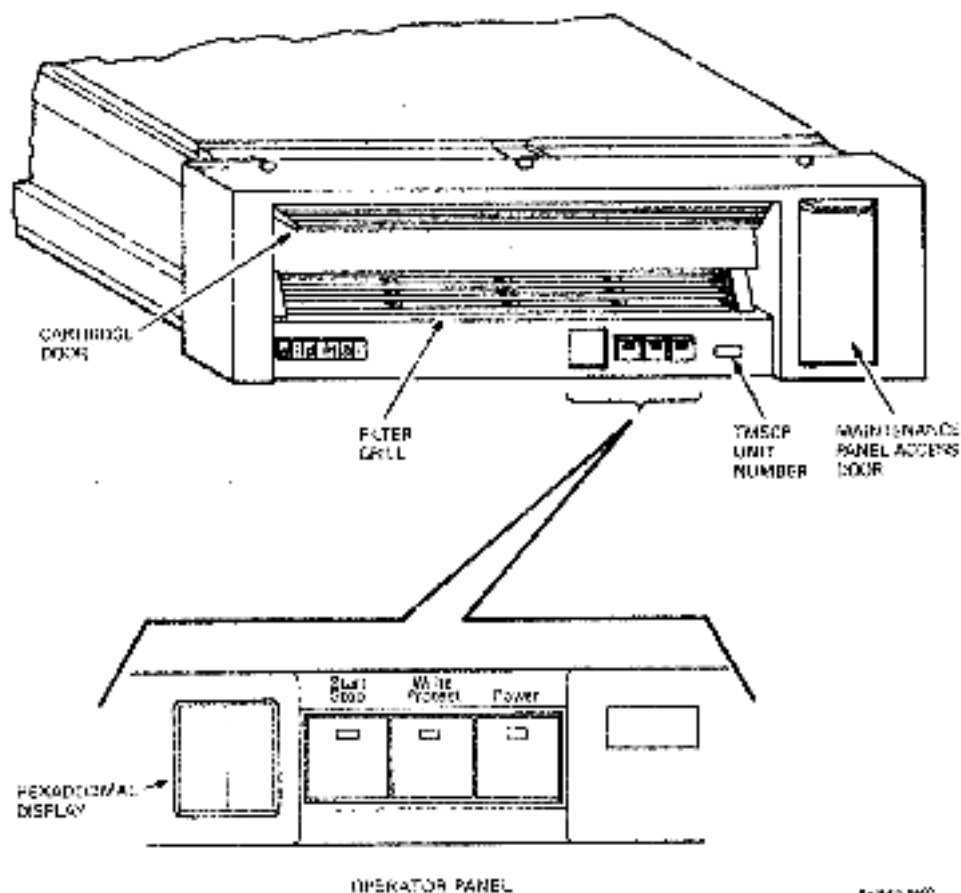

- **Cartridge Door**  
When opened, allows a disk to be inserted into the drive. When closed, protects the internal parts of the RV20 from exposure to dust and dirt. Excessive dust and dirt can damage the sensitive internal components of the drive.
- **Filter Grill**  
This grill houses the air filter inside the RV20 drive. The filter allows air to circulate within the drive while preventing dust and dirt from getting inside the drive.
- **Operator Panel (Table 3-1)**  
This is the operator interface on the RV20. The operator panel consists of the Hexadecimal Display, the Start/Stop-Ready switch/indicator, the Write Protect switch/indicator, and the Address Switch/Power Indicator. Table 3-1 describes these in more detail.
- **TMSCP Unit Number**  
This is the TMSCP unit number of the particular RV20 drive, assigned during installation by a Digital Field Service engineer. This number must be used in commands in order to communicate with the drive. Consult your system manager or host system documentation if you need more information on unit numbers and their use.
- **Maintenance Panel Access Door**  
Opening this door allows access to the maintenance panel, which is for use by specially trained Digital Field Service engineers. Random use of the maintenance panel by untrained personnel can cause major failures in the RV20. The only time a user should access the maintenance panel is when instructed to by a Digital Field Service representative.

**Table 3-1: RV20 Operator Panel**

Switch/Indicator	Type/Color	Action
Hexadecimal Display	2 Red LEDs	This display gives a 2 digit hexadecimal drive status code. When a failure is detected, FA is displayed and the drive stops functioning. During a diagnostic session, this display flashes test results.
Start/Stop Switch	Pushbutton	When a disk is inside the RV20, pressing this switch in (the Start position) causes the spindle motor to spin the disk up to speed.  When this switch is already in the Start position, pressing it out (the Stop position) causes the spindle motor to spin the disk down.
Ready Indicator	Green LED	When lit, indicates that the spindle motor is up to speed.  When flashing, indicates that the spindle is in the process of spin-up or spin-down.  When not lit, indicates that the spindle motor is off.
Write Protect Switch	Pushbutton	Pressing this switch prevents any writing to the disk inside the RV20.
Write Protect Indicator	Yellow LED	When lit, indicates that the disk inside the RV20 is write protected. This indicator will be lit regardless of which of the two methods of write protection has been used (Paragraph 3.5).
Power Indicator	Green LED	This indicator lights when power is present inside the drive.
ISI Address Plug	Switch Cap	Encodes the ISI address (0 to 3). This is for use during installation by specially trained Digital Field Service engineers.

### 3.3 Power-Up

There is no physical power switch that you have to use to get the RV20 up and running. When the RV20 subsystem is on, the Power indicators on **all** the drives in the subsystem should be lit. If a Power indicator is off on any of the RV20s in the subsystem, refer to Paragraph 4.3, Problem Solving.

### 3.4 RV20 Media

The RV20 uses 12-inch optical disks that are stored in plastic cartridges. The RV20 drive accesses the disk inside the cartridge through two access doors (Figure 3-2). These doors open when the disk is inserted into the drive. These access doors should never be opened by hand!

Figure 3-2: RV20 Disk Cartridge

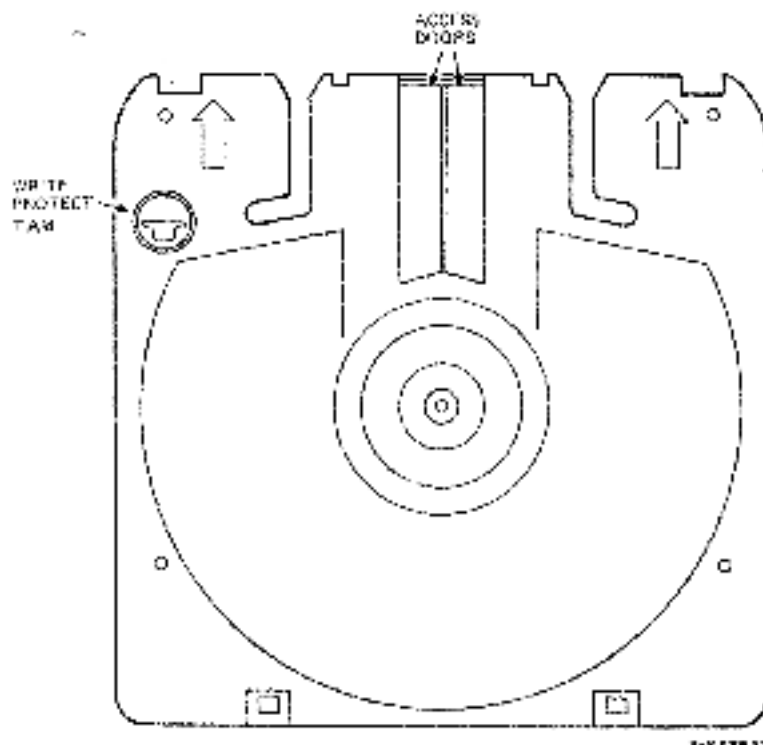

## 3.5 Write Protecting a Disk

Write protecting a disk prohibits the RV20 from writing on a disk. There are two ways to write protect a disk: with the front panel write protect switch, or with the Write Protect tab on the disk. If a disk is write protected, the write protect indicator on the front panel lights, regardless of which method of write protection is used.

When a disk is in the RV20, pressing the Write Protect switch on the front panel write protects the disk. The Write Protect indicator on the switch lights.

The best way to write protect a disk is to set the Write Protect tab located on the disk. Figure 3-2 shows the location of the Write Protect tab on the disk cartridge. There is a write protect tab on each side of a double-sided disk. Remember that the bottom surface is the surface that is read in the drive.

Figure 3-3 shows the settings of the write protect tab. To change the setting of the Write Protect tab, take a large flat-head screwdriver and rotate the tab 180 degrees. The outer rim of the tab is labeled WRITE and WRITE PROTECT. The arrow on the tab points to the current disk setting. When the arrow is pointing toward the front of the disk (as shown in Figure 3-3), the disk is WRITE ENABLED (not write protected).

Figure 3-3: Write Protecting a Disk

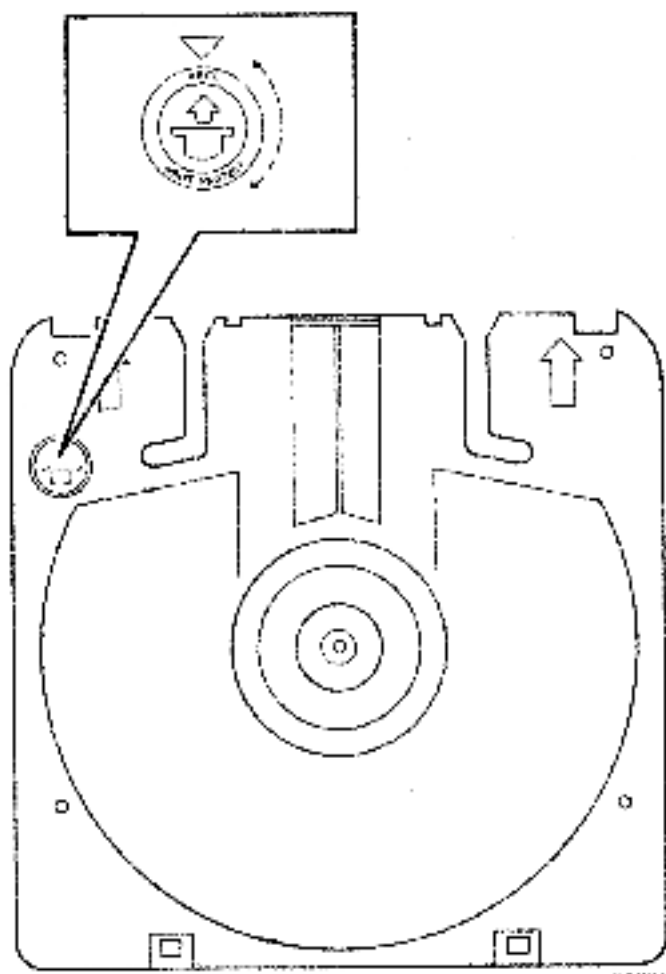

### 3.6 Loading/Spinning Up a Disk

When loading a disk, make sure you are loading the side you want to use. The sides of the disk cartridge are stamped A and B. When inserting the disk, the letter that is on the left side of the disk cartridge is the side that you are inserting for use.

To load and spin up a disk, proceed as follows.

1. Open the cartridge door.
2. Push the disk in as far as it will go. Make sure you are putting in the correct side. Figure 3-4 shows side A being inserted. Remember that side A is the bottom side of the inserted disk in Figure 3-4.
3. Close the cartridge door.
4. Press the Start/Stop switch in (the Start position). The Ready indicator (located on the Start/Stop switch) flashes while the spindle is coming up to speed. When the spindle is up to speed, the Ready indicator stays on continuously.

### 3.7 Host Initiated Spin-Up/Spin-Down

When a disk is initially spun up with the Start/Stop switch, it can then be spun up and spun down by the host computer. The disk **must** initially be spun up with the switch, however! The host cannot spin the disk up or down unless the Start/Stop switch is in the Start position.

### 3.8 Spinning Down/Unloading a Disk

To spin down a disk and unload it from the RV20, reverse the procedures given in Paragraph 3.6 (See Figure 3-4 as necessary).

1. Press the Start/Stop switch to the out (Stop) position. If the host computer is not communicating with the drive, the spin down occurs. If the host is communicating with the drive, the spin down is delayed until the activity with the host ceases (for a period of at least 300 milliseconds). Upon spin down, the Ready indicator (located on the Start/Stop switch) flashes while the spindle spins down. When the spindle has stopped, the flashing Ready indicator goes off.
2. When the Ready indicator is off, open the cartridge door.
3. Pull the disk all the way out of the drive.
4. Close the cartridge door.

**Figure 3-4: Loading a Disk**

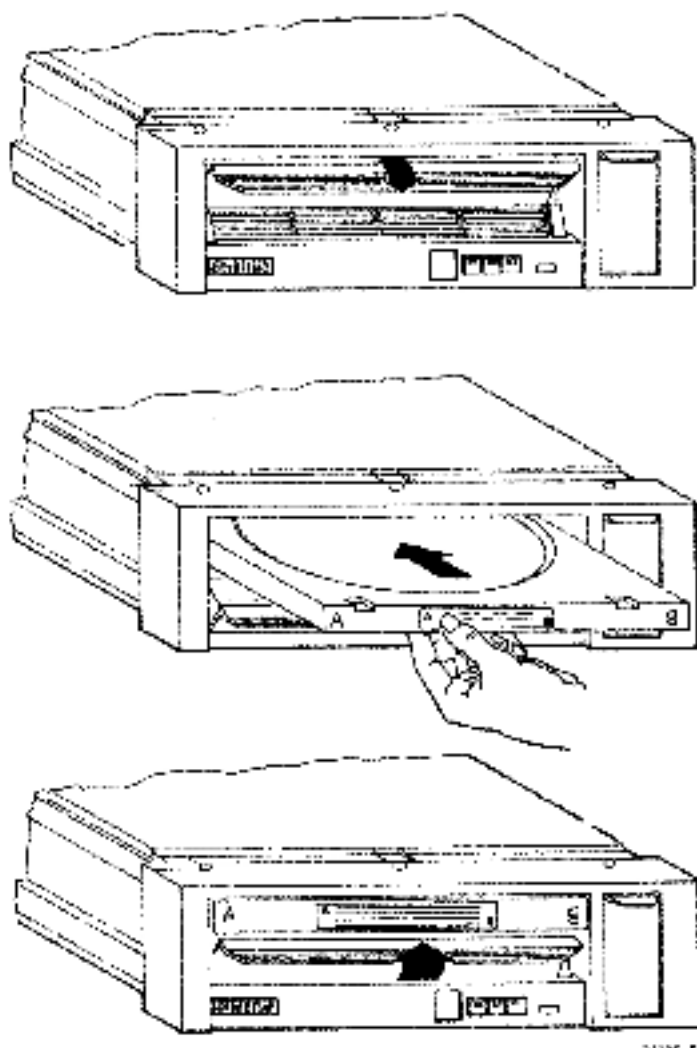



## Chapter 4

---

# Maintenance and Problem Solving

The only regular maintenance required for the drives in the RV20 subsystem is to clean the air filter in each RV20 drive twice a year and to replace the filters, if necessary.

### 4.1 Filter Replacement/Cleaning

The filter is located inside the filter grill on the front of the RV20 (Figure 4-1). To access the filter, you have to remove the filter grill. Proceed as follows:

1. Take the drive off-line with the appropriate host command.
2. If there is a disk in the drive, remove it. (Refer to Chapter 3 if necessary.)
3. Push the grill tab on the front of the RV20 to the right so that the filter grill comes out slightly (Figure 4-1).
4. Swing the filter grill out and remove it.
5. Remove the filter from the grill and inspect it for frayed edges or excessive dirt buildup. Replace it, if necessary (PN 29-26448-00).
6. If you are replacing the filter, put the new filter inside the filter grill and go to step 7. If you are cleaning the filter, proceed as follows:
  - a. Clean the filter by rinsing it in ordinary tap water.
  - b. Let it stand for at least 10 minutes to completely dry.
  - c. Put the clean, dry filter back inside the filter grill.

7. Place the left side of the filter grill into its slot on the front of the drive.
8. Swing the right side of the grill into its slot until it snaps into place. Open and close the cartridge door to be sure if the grill is installed correctly. If the door won't open freely, the filter grill is not in all the way or is installed backwards.

**Figure 4-1: Filter Removal**

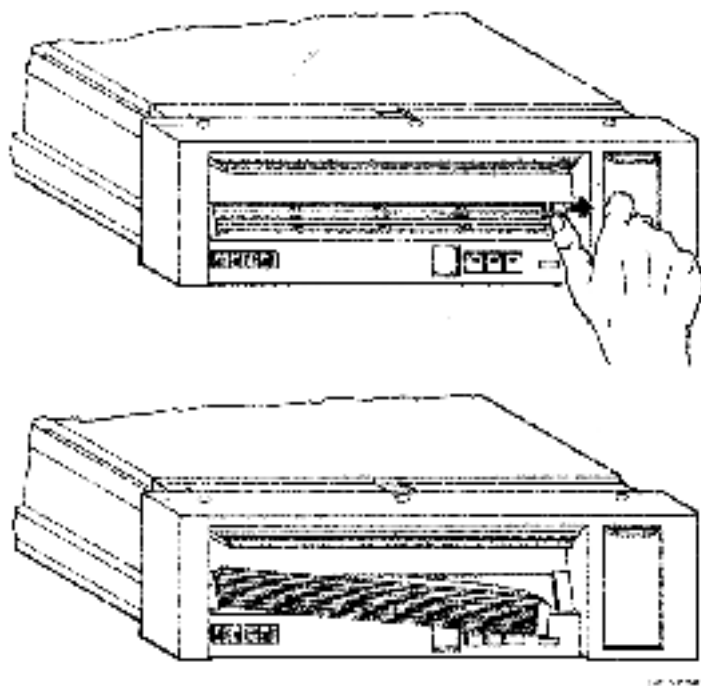

## 4.2 Cartridge Replacement/Disk Cleaning

The optical disk is inside a plastic cartridge. If a disk cartridge is damaged, it can be replaced. If you are replacing a cartridge, the disk inside the cartridge should be cleaned as part of the cartridge replacement procedure.

The cartridge assembly consists of two molded pieces of plastic, joined together with four tabs. There are two tabs on each side of the cartridge (Figure 4-2). Each tab has a tab release. Using Figure 4-2 as a guide, identify the tabs and tab releases on your disk cartridge.

If the cartridge is damaged, the disk inside it may be saved by replacing the cartridge with a new one. A new cartridge assembly (PN 30-27642-02) can be ordered through your Digital Field Service representative.

To remove a cartridge, clean the disk, and put the disk into a new cartridge, proceed as follows.

1. Position the cartridge so the tab releases are on the bottom (as shown in Figure 4-2).

**Figure 4-2: Disk Cartridge Parts**

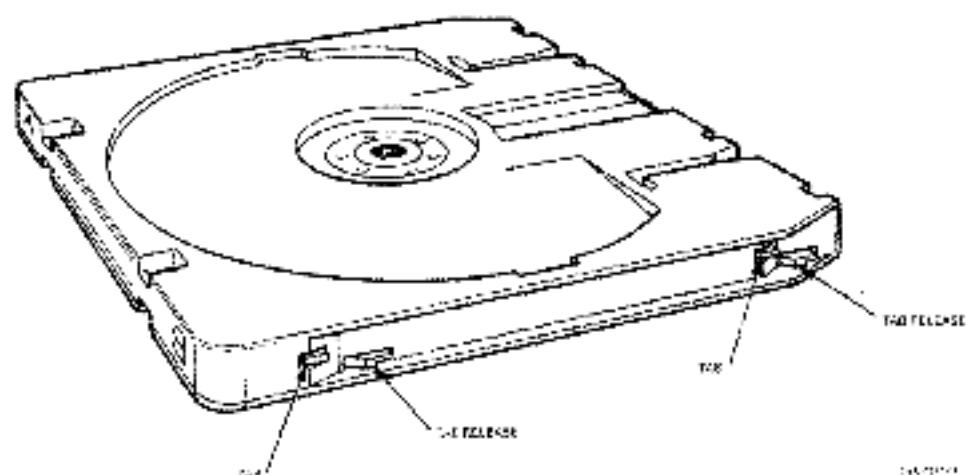

2. Push each of the four tab releases to disengage the two parts of the cartridge (Figure 4-3).
3. Position your hands on the cartridge as in Figure 4-3. Your thumbs should be on the top piece of the cartridge while your fingers are on the bottom piece of the cartridge.
4. Using inward pressure with your fingers and outward pressure with your thumbs, separate the two parts of the cartridge (Figure 4-3). You may have to use considerable pressure to separate the two pieces.
5. Carefully remove the disk from the bottom piece of the cartridge assembly. Be sure to note the orientation of sides A and B as you lift the disk out. You must put the disk into the new cartridge with the same side up.
6. Use a dry, lint-free cloth to clean the disk surface. Wipe the disk from the center toward the outer edges with the cloth. **Never wipe the disk in a circular motion!**  
  
Clean both sides of the disk. Be very careful when handling it. Fingerprints and dust can damage the disk.
7. Place the disk in the new cartridge assembly. Make sure that the sides are oriented exactly as they were in the old cartridge.

**Figure 4-3: Disengaging the Cartridge Parts**

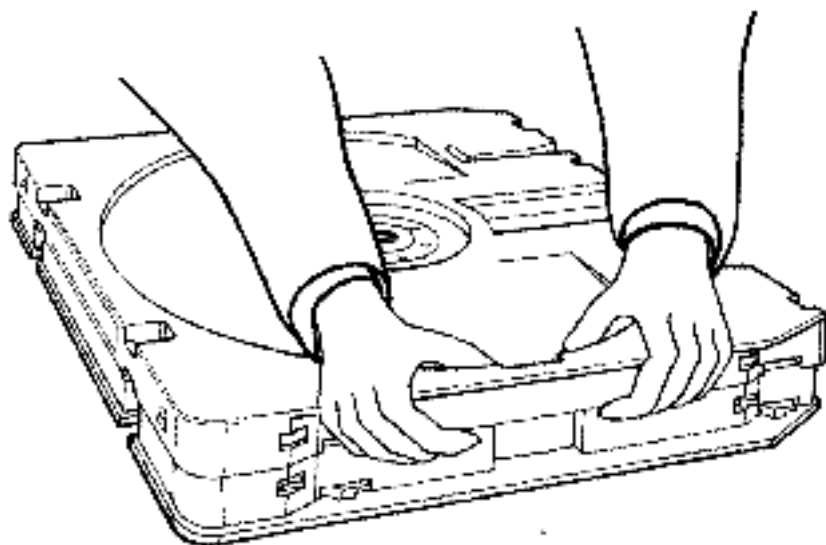

8. Position the top piece of the new cartridge assembly as shown in Figure 4-4 with one side already snapped into place.
9. Bring the top piece down onto the bottom piece of the cartridge and snap into place.
10. Push in each tab release to join the two cartridge pieces together.

**Figure 4-4: Separating the Cartridge Parts**

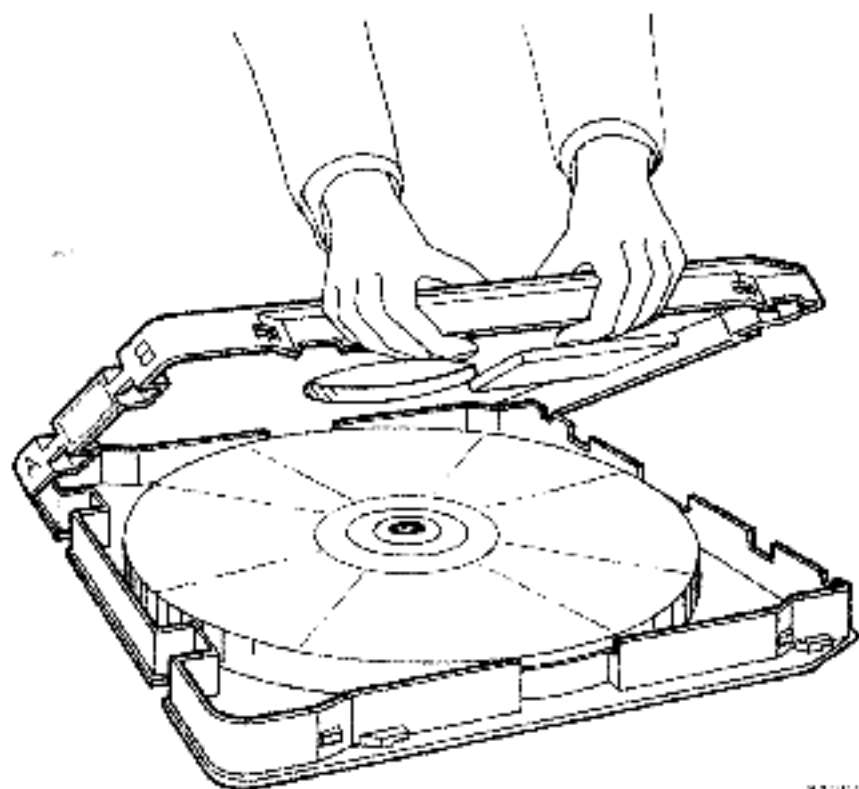

## 4.3 Problem Solving

Table 4-1 lists some problems you may encounter during everyday use of the RV20 subsystem. The table also lists possible causes and solutions for you to try before calling your Digital Field Service representative.

**Table 4-1: Problem Solving**

<b>Problem</b>	<b>Possible Cause</b>	<b>Possible Solution</b>
Cartridge door won't open	Disk is still spinning inside drive.	Spin down disk with Start/Stop switch.  Take drive off-line with applicable host command.
	Filter grill is in the way of the cartridge door.	Install filter grill correctly (Chapter 4).
Cartridge door won't close	Disk is not fully inserted.	Insert disk fully (Chapter 3).
No power (entire subsystem)	Primary wall power is dead.	Check wall power.
	Power controller malfunction.	Call Digital Field Service.
No power (only one drive in subsystem)	Operator panel indicator is burned out.	Insert disk and attempt to spin disk up. Try to bring drive on-line from host.  Call Digital Field Service.
	Drive malfunction	Call Digital Field Service.
Operator panel display reads FA	Drive malfunction	Call Digital Field Service.
Subsystem won't bring drive on-line	No disk is installed or installed disk is not spun up	Insert a disk and spin it up.
Subsystem won't bring drive off-line	Host is communicating with drive.	Wait until host communication stops and try again.
Mounted drive will not respond to host commands	Drive is "hung up."	Try to spin disk down with Start/Stop switch.  Call Digital Field Service.

## 4.4 Digital Repair Services

Digital Field Service offers a range of flexible service plans.

**ON-SITE SERVICE** offers both the convenience of service at your site and insurance against unplanned repair bills. For a small monthly fee, you receive personal service from our service specialists. Within a few hours, the specialist is dispatched to your site with equipment and parts to give you fast and dependable maintenance.

**BASIC SERVICE** offers full coverage from 8 a.m. to 5 p.m., Monday through Friday. Options are available to extend your coverage to 12-, 16-, or 24-hour days, and to Saturdays, Sundays, and holidays.

**DECservice** offers a premium, on-site service providing committed response to remedial service requests made during contracted hours of coverage. Remedial maintenance will be performed continuously until the problem is resolved, which makes this service ideal for customers requiring maximum service performance.

Under Basic Service and DECservice, all parts, materials, and labor are covered in full.

**CARRY-IN SERVICE** offers fast, personalized response, and the ability to plan your maintenance costs for a smaller monthly fee than On-Site Service. When you bring your unit to one of 160 Digital Servcenters worldwide, factory-trained personnel repair your unit within two days. This service is available on selected terminals and systems. Contact your local Digital Field Service office to see if this service is available for your unit.

Digital Servcenters are open during normal business hours, Monday through Friday.

**DECmailer** offers expert repair at a per use charge. This service is designed for users who have the technical resources to troubleshoot, identify, and isolate the module causing the problem. Mail the faulty module to our Customer Returns Center where the module is repaired and mailed back to you within five days.

PER CALL SERVICE offers a maintenance program on a noncontractual, time-and-materials-cost basis. This service is available with either On-Site or Carry-In Service. It is appropriate for customers who have the expertise to perform first-line maintenance, but may occasionally need in-depth support from Field Service.

Per Call Service is also offered as a supplementary program for Basic Service customers who need maintenance beyond their contracted coverage hours. There is no materials charge in this case.

On-Site Per Call Service is provided on a best effort basis, with a normal response time of two to three days. It is available 24 hours a day, seven days a week.

Carry-In Per Call Service is available during normal business hours, with a two to three day turnaround.

For more information on these Digital service plans, prices, and special rates for volume customers, call the Digital Field Service office nearest you.

# Index

---

## A

---

Applications, 2-2

## B

---

BACKUP, 2-2

Block size, 2-7, 2-8

BOOT, 2-2, 2-4

## C

---

Cartridge

Access doors, 3-5

Replacing, 4-4 to 4-5

Cartridge replacement, 4-3

Controls, 3-3

COPY, 2-2

## D

---

Disk tunes, 2-6

Disk

Cleaning, 4-3 to 4-4

Loading, 3-8, 3-9

Unloading, 3-8

Write protecting, 3-6

Disk cleaning, 4-3

Disk construction, 1-1, 1-6

Disk storage capacity, 1-1, 1-6

DISMOUNT, 2-2

Drive subsystem controller module,  
1-2, 1-3

## E

---

Environmental requirements, 1-4

Error log report, 2-3

## F

---

File maintenance, 2-3

File positions, 2-6

File versions, 2-3

Filter, 3-3

Cleaning, 4-1

Replacing, 4-1 to 4-2

Front panel, 3-2

## I

---

Indicators, 3-1

Initializing, 2-2

ISI address, 1-3, 3-4

## K

---

K(ES) adapter, 1-3

## L

---

Laser, 1-1, 1-4

LEOT, 2-6

LES1 adapter, 1-3

LESI bus, 1-3

## M

---

Maintenance, 4-1

Maintenance panel, 3-3

MOUNT, 2-2

## O

---

Operator panel, 3-3

Overwriting files, 2-4

## P

---

Performance, 2-6

Power indicator, 3-4

Power-up, 3-5

Problem solving, 4-1, 4-6

## Q

---

QIO, 2-2

## R

---

RA- disk drive, 1-2

Ready indicator, 3-4, 3-8

Related documentation, 1-5

Repair services, 4-7

Rewind operations, 2-7

## S

---

Safety requirements, 1-4

Software, 2-1

Specifications, 1-5

Start/Stop switch, 3-4, 3-8

Subsystem

    Configurations, 1-2

    Overview, 1-2

## T

---

Transfer rates, 2-7

## U

---

Unit number, 3-3

## W

---

Write Protect indicator, 3-4, 3-6, 3-7

Write protecting, 3-6

Write Protect switch, 3-4, 3-6, 3-7