

EK-0RC25-UG-002

RC25 Disk Subsystem

User Guide

digital

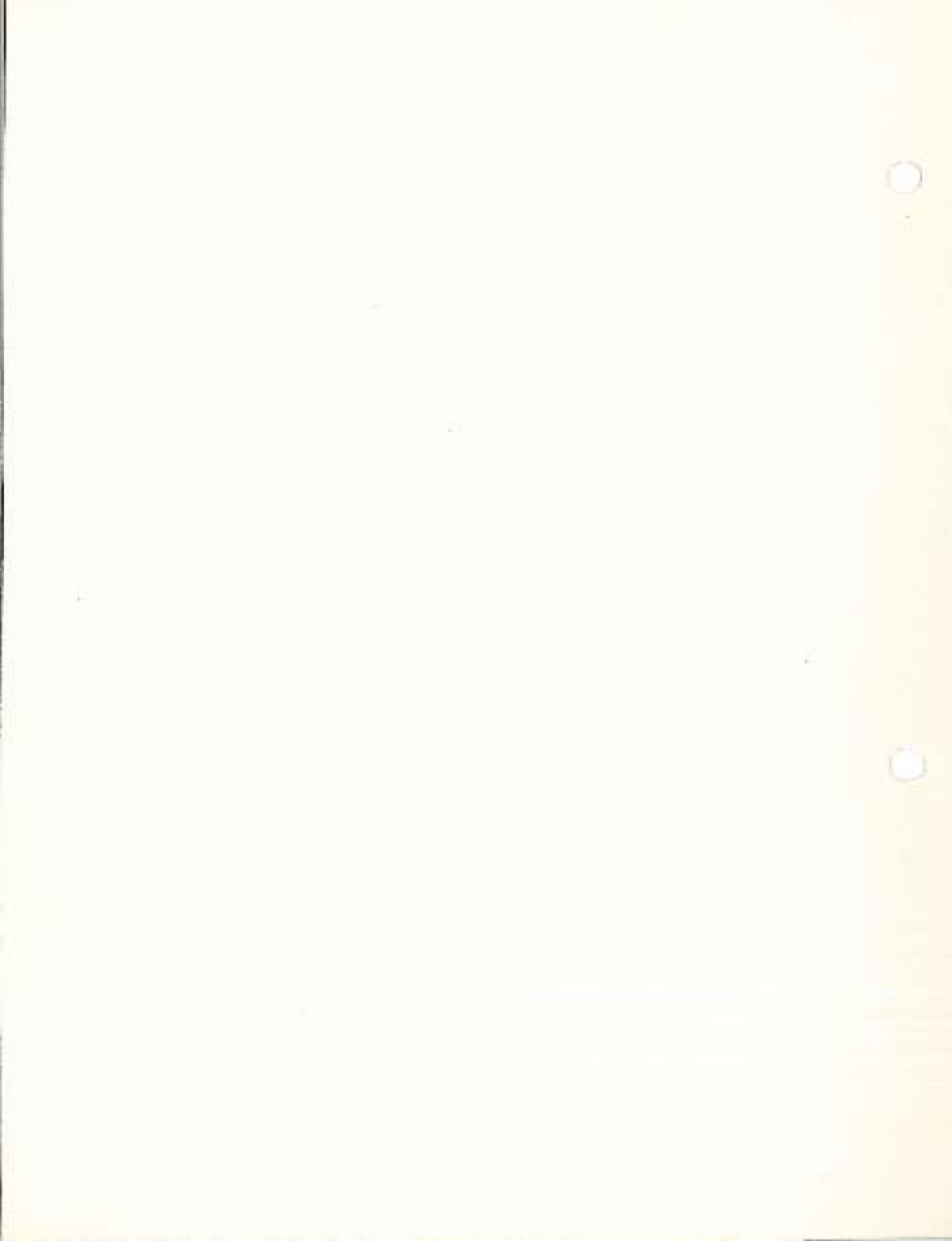

RC25 Disk Subsystem

User Guide

Prepared by Educational Services
of
Digital Equipment Corporation

1st Edition, September 1983

Copyright © 1983 by Digital Equipment Corporation. All Rights Reserved.
Printed in U.S.A.

The reproduction of this material, in part or whole, is strictly prohibited. For copy information, contact the Educational Services Department, Digital Equipment Corporation, Maynard, Massachusetts 01754.

The information in this document is subject to change without notice. Digital Equipment Corporation assumes no responsibility for any errors that may appear in this document.

FCC Notice

This equipment generates, uses, and may emit radio frequency energy. The equipment has been type tested and found to comply with the limits for a Class A computing device pursuant to Subpart J of Part 15 of FCC Rules, which are designed to provide reasonable protection against such radio frequency interference when operated in a commercial environment.

Operation of this equipment in a residential area may cause interference in which case the user at his own expense may be required to take measures to correct the interference.

The following are trademarks of Digital Equipment Corporation, Maynard, Massachusetts.

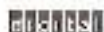

DEC

DECdirect

DECmat

DECmate

DECsystem-10

DECSYSTEM-20

DECUS

DECwriter

DIGITAL

EduSystem

MASSBUS

Media Mate

OMNIBUS

PDP

PDT

Professional

Rainbow

RSTS

RSX

UNIBUS

VAX

VMS

VT

Work Processor

CONTENTS

PREFACE

CHAPTER 1 INTRODUCTION TO THE RC25

Description	1
Features	2
Configurations and Options	3
Disk Subsystems	6
Related Documentation	9
Specifications	10

CHAPTER 2 SITE PREPARATION

Environment	15
Power	16
Space	16
Moving	20

CHAPTER 3 OPERATOR INFORMATION

Operator Controls and Indicators	21
Voltage Selection	22
Turning Power On and Off	22
Operator Panel	24
Miscellaneous Indicators	24
Run	26
Write Protect	27
Eject	28
Fault	29
Indicator Function Summary	30
Unit Select Number	31

Loading, Unloading, and Operating Procedures	32
Cartridge Loading	32
Cartridge Unloading	32
Disk Operating Procedures	34

CHAPTER 4 CUSTOMER CARE

Responsibilities	37
Care of the Disk Drive	37
Care of the Disk Media	38
Handling Practices and Precautions	38
Storage	39

CHAPTER 5 SOLVING PROBLEMS

Identifying and Correcting Problems	41
Faults and Fault Codes	44
Controller Fail Indicator	44
Fault Indicator	46
Fault Code 11: Interface Cable	47
Fault Codes 12 and 13: Software	48
Fault Code 14: AC Line Voltage	49
Fault Code 15: Temperature	50
Fault Code 16: Unit Select Number	51
Fault Codes 30, 31, and 32: Disk Format	52
Verification Tests	54
Test 1: Power-On Check	54
Test 2: Disk and Head Load Check	55
Test 3: Quick Verification	56
Test 4: Extended Verification	57
Service Options	57
Digital Field Service	57
Self-Maintenance	57

CHAPTER 6 ACCESSORIES, SUPPLIES, AND SERVICES

Spare Parts and Documentation	59
Ordering Information	60
Support Services	62
Field Service	62
On-Site Service	62
Customer Spares	62
Educational Services	62
Software Services	62

APPENDIX A PROGRAMMER INFORMATION**APPENDIX B HOW TO MODIFY THE UNIT SELECT NUMBER PLUG****GLOSSARY****FIGURES**

1-1	RC25 Tabletop Disk Drive	3
1-2	RC25 Rack-Mounted Disk Drive	4
1-3	RC25 Disk Subsystem Components	7
1-4	RC25 Master and Slave Disk Drives	8
2-1	Space Planning for the Tabletop Unit	17
2-2	Space Planning for the Rack-Mount Unit	18
2-3	Rack-Mount Unit and Service Clearances	19
3-1	Voltage Selector Switch and ON/OFF Circuit Breaker	23
3-2	RC25 Front View Showing Operator Panel	25
3-3	Operator Panel	26
3-4	Changing the Unit Select Number Plug	31
3-5	Inserting the Disk Cartridge	33
5-1	Controller Fail Indicator	45
5-2	Fault Indicator	46
5-3	Fault Code 11: Interface Cable	47
5-4	Fault Code 12: Software	48
5-5	Fault Code 13: Software	48
5-6	Fault Code 14: AC Line Voltage	49
5-7	Fault Code 15: Temperature	50
5-8	Fault Code 16: Unit Select Number	51
5-9	Fault Code 30: Disk Format	52
5-10	Fault Code 31: Disk Format	53
5-11	Fault Code 32: Disk Format	53
B-1	Unit Select Number Switch	69
B-2	Setting the Unit Select Number Switch	70

TABLES

1-1	RC25 Disk Drive Options	5
1-2	RC25 Disk Subsystem Documentation	9
3-1	Indicator States and Their Meaning	30
5-1	Isolating and Correcting Problems	42
6-1	Accessories and Supplies	60
B-1	Unit Select Number Switch Settings	71

PREFACE

This guide is for the owner and operator of the RC25 Disk Drive. Its chapters are divided into three categories.

- Product introduction
- Operation
- Support

The chapters are arranged by function so you can reference a specific chapter according to the function you plan to perform.

Chapter 1, "Introduction to the RC25," tells you about the product and its features. It also lists the product's specifications.

Chapter 2, "Site Preparation," describes how to plan for installing the RC25 for the first time or moving it to another location.

Chapter 3, "Operator Information," shows the operator controls and indicators on the RC25. It also provides procedures for loading and unloading the disk. Detailed operating information depends on the computer system/software environment.

Chapter 4, "Customer Care," identifies the tasks and responsibilities of the operator to maintain the RC25 and cartridges.

Chapter 5, "Solving Problems," provides procedures for checking and identifying failures in the RC25. You may be able to solve some problems before calling for service. This chapter also provides a series of checks to ensure that your disk is functioning correctly.

Chapter 6, "Accessories, Supplies, and Services," describes additional products for the RC25. It includes a short description of each product, part numbers, and ordering information. Also included is a summary of the many supporting services available from Digital Equipment Corporation.

Appendix A, "Programmer Information," lists resource material available for customers who want to write an I/O driver for the RC25.

Appendix B, "How to Modify the Unit Select Number Plug," explains what to do if you want to use a unit number of 8/9 or higher for the RC25.

The glossary lists and describes some of the technical words and concepts introduced in this guide. Italicized words in the chapters are in the glossary.

For information on how to install the RC25, refer to the *RC25 Slave Disk Drive Customer Installation Guide* (EK-RC25S-IN) or the *RC25 Disk Subsystem Installation Guide* (EK-ORC25-IN) for Digital Field Service.

INTRODUCTION TO THE RC25

This chapter introduces you to the RC25 with an overview of what it is and what it does. This chapter also includes a list of available configurations, a list and description of the family of documents that support the RC25, and a summary of operating and performance specifications.

DESCRIPTION

The RC25 is a low-cost, self-contained mass storage device that can be used with a host computer in a wide range of applications. It contains 8-inch removable and nonremovable hard disk media. It has a data storage capacity of 52 million characters. The RC25 is available in tabletop and rack-mount versions.

The *disk drive* contains two 8-inch, double-sided, disk *platters*. One platter is fixed and one is removable. The fixed platter has a capacity of 26 million characters and cannot be removed by the user. The removable platter, contained in a *cartridge*, has a capacity of 26 million characters and can be removed and replaced as needed. Both disk platters are mounted on and driven by the same *spindle*.

FEATURES

The RC25 is a small, low-weight disk drive with the following features.

Performance

- Low power use
- Low acoustical noise
- Complete system operation with a single spindle
- Overlapped seek operations with a dual disk drive configuration that lower subsystem overhead
- Seek optimization on each spindle
- Independent manual write protection for fixed and removable media

Data Integrity

- Protected media (fixed disk sealed in disk drive and cartridge disk sealed until loaded into the disk drive)
- Powerful error detection and correction before transmission to the host computer
- Automatic retry when an error is encountered

Reliability/Availability

- Self-tests allow verification of disk operation
- Internal fault detection and isolation diagnostics that lower mean time to repair
- No preventive maintenance necessary
- No adjustments
- Easy access to field replaceable units when maintenance is necessary

CONFIGURATIONS AND OPTIONS

The RC25 is available as a free-standing tabletop unit or as a unit that fits into a standard 19-inch rack-mounting frame. Figure 1-1 shows the tabletop unit and Figure 1-2 shows the rack-mounted unit. With each type, the RC25 is available in the master and slave configuration. The next section, "Disk Subsystems," explains more about the master/slave relationship.

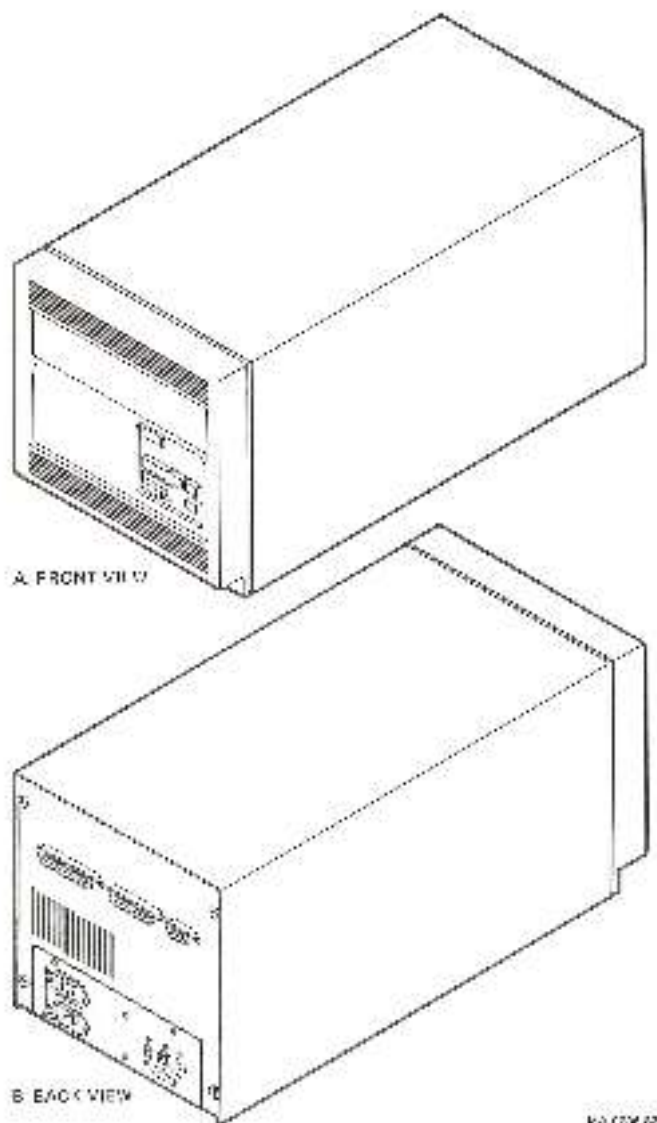

Figure 1-1 RC25 Tabletop Disk Drive

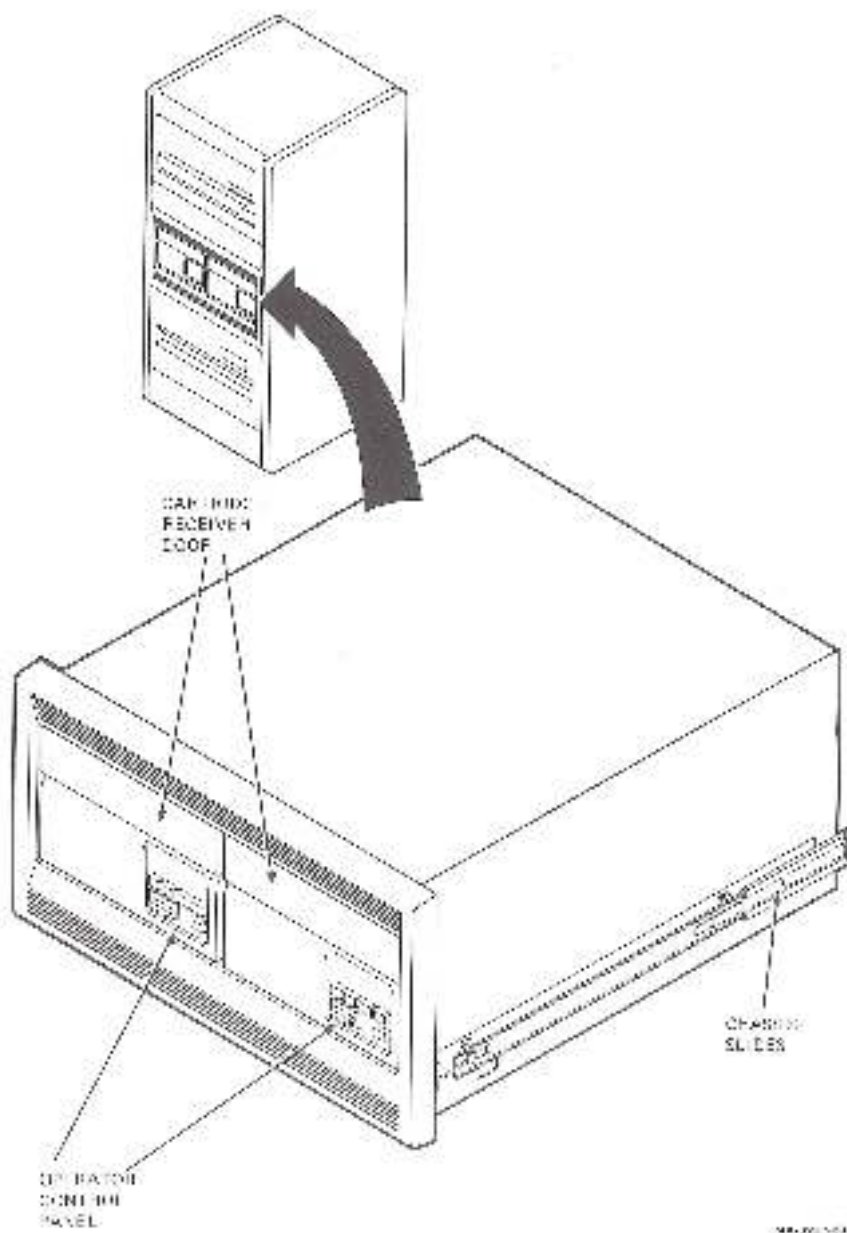

Figure 1-2 RC25 Rack-Mounted Disk Drive

Table 1-1 lists the options available with the RC25. Options are specified according to the *host system* type, the mounting requirements, and the master/slave variation.

Table 1-1 RC25 Disk Drive Options

Option	Host System Bus	Description
RUC25-AA	UNIBUS	Single RC25 master tabletop disk drive, 120 Vac power, UNIBUS interface (KLESI-UA), interface cable, one RC25K-DC disk cartridge
RUC25-BA	UNIBUS	Single RC25 master rack-mount disk drive, 120 Vac power, UNIBUS interface (KLESI-UA), interface cable, one RC25K-DC disk cartridge
RUC25-CA	UNIBUS	Dual RC25 master/slave rack-mount disk drive, 120 Vac power, UNIBUS interface (KLESI-UA), interface cable, two RC25K-DC disk cartridges
RQC25-AA	LSI-11	Single RC25 master tabletop disk drive, 120 Vac power, LSI-11 bus interface (KLESI-QA), interface cable, one RC25K-DC disk cartridge
RQC25-BA	LSI-11	Single RC25 master rack-mount disk drive, 120 Vac power, LSI-11 bus interface (KLESI-QA), interface cable, one RC25K-DC disk cartridge
RQC25-CA	LSI-11	Dual RC25 master/slave rack-mount disk drive, 120 Vac power, LSI-11 bus interface (KLESI-QA), interface cable, two RC25K-DC disk cartridges
RC25-DA	NA	Single RC25 slave tabletop add-on disk drive, 120 Vac power, drive cables, one RC25K-DC disk cartridge
RC25-EA	NA	Single RC25 slave rack-mount add-on disk drive, 120 Vac power, drive cables, one RC25K-DC disk cartridge

Table 1-1 RC25 Disk Drive Options (Cont)

Option	Host System Bus	Description
RC25K-DC	NA	RC25 26-megabyte data cartridge
KLESI-UA	UNIBUS	UNIBUS to low end storage interconnect (LESI) adapter module
KLESI-QA	LSI-11 bus	LSI-11 bus (16-, 18-, or 22-bit) to LESI adapter module

DISK SUBSYSTEMS

The RC25 *disk subsystem* is made of two major components. The first component is the disk drive itself, which contains the disk platters with supporting mechanics and electronics. The second component is the *adapter module*. The adapter module is an electronic package that allows a specific host computer system to communicate with the disk drive. For example, Digital's UNIBUS systems use one adapter (KLESI-UA), while the LSI-11 bus systems use another (KLESI-QA).

Figure 1-3 shows a typical RC25 disk subsystem. The adapter module plugs into the host computer system *bus*. The disk drive connects to the adapter via an interface cable.

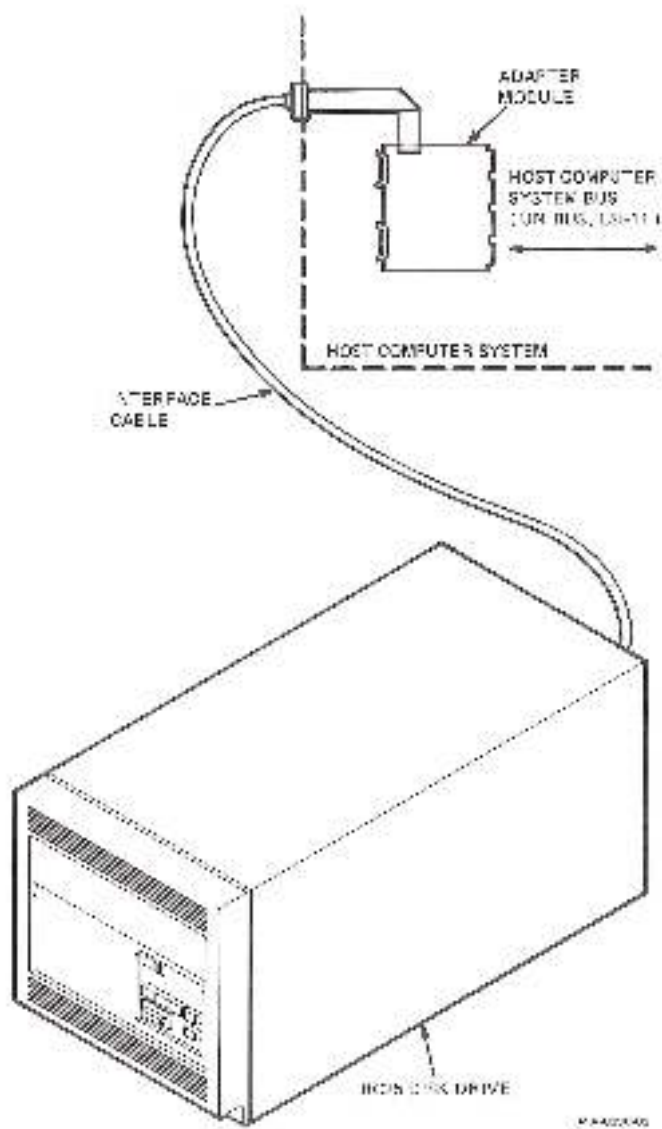

Figure 1-3 RC25 Disk Subsystem Components

The RC25 is available as a master or a slave (Figure 1-4). The master drive contains a controller module that connects to the adapter module. The slave drive does not contain a controller module. The slave connects to the master via the drive interface cable set. The first drive in a subsystem must be the master. Each master drive can control up to two disk spindles, which include the master spindle and slave spindle.

The master/slave distinction is made when ordering or installing the product. In normal operation, the host computer does not distinguish between master and slave because each disk drive has a unique unit number. *Disk cartridges* can be moved between master and slave as needed.

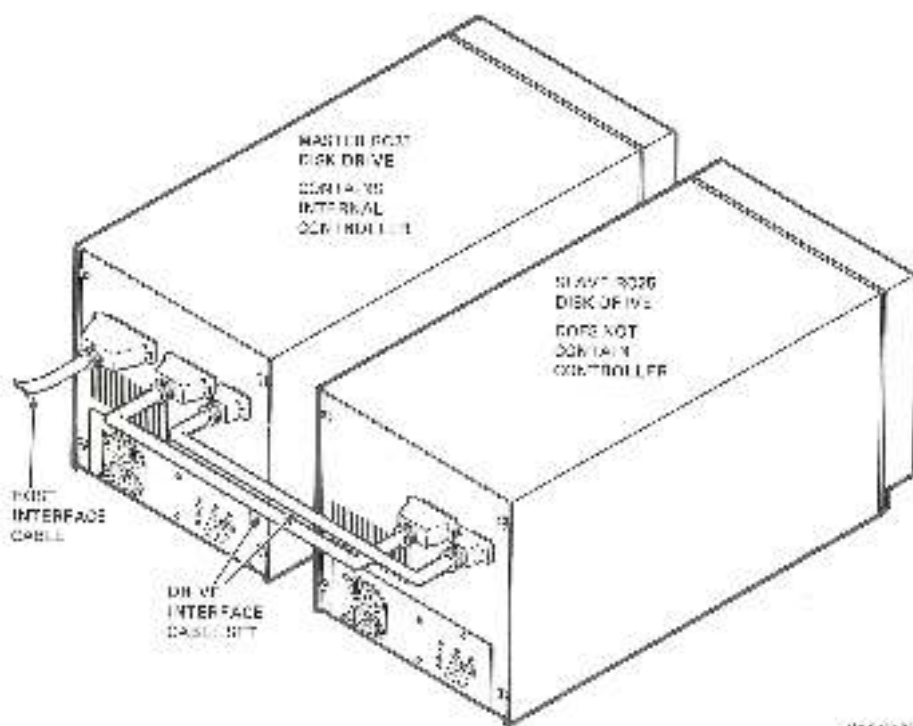

Figure 1-4 RC25 Master and Slave Disk Drives

RELATED DOCUMENTATION

Table 1-2 lists documents that add to the information in this guide.

Table 1-2 RC25 Disk Subsystem Documentation	
Part Number	Description
EK-0RC25-UG	<i>RC25 Disk Subsystem User Guide</i> – covers site planning, operation, care, ordering accessories, and first-level problem diagnosis.
EK-RC25M-IN	<i>RC25 Master Disk Drive Customer Installation Guide</i> – has procedures for installing the master tabletop disk drive and running interface cables.
EK-RC25S-IN	<i>RC25 Slave Disk Drive Customer Installation Guide</i> – has procedures for installing the slave tabletop disk drive and running interface cables.
EK-0RC25-IN	<i>RC25 Disk Subsystem Installation Guide</i> – is a Field Service guide to site planning, installing the disk subsystem (tabletop unit, rack-mount unit, adapter modules), and performance verification.
EK-0RC25-PS	<i>RC25 Disk Subsystem Pocket Service Guide</i> – has procedures for troubleshooting and repairing the RC25 to the field replaceable unit.
EK-0RC25-IP	<i>Illustrated Parts Breakdown</i> – is a detailed parts breakdown of the RC25. It does not provide part numbers for the printed circuit module components.
MP-01612-00	<i>RC25 Field Maintenance Print Set</i> – is an arrangement of engineering drawings relating to the disk and adapter modules. It includes mechanics, electronics, and the power supply.
AA-L619A-TK	<i>MSCP Basic Disk Functions Manual</i> – is for programmers and defines the Digital standard mass storage control protocol.
AA-L621A-TK	<i>Storage Systems UNIBUS Port Description</i> – is for programmers and defines the Digital standard UNIBUS and LSI-11 bus port protocol.

SPECIFICATIONS

The following list names the primary performance, power, environmental, and physical characteristics of the RC25.

Size**Tabletop model**

Height	25.6 cm (10-1/8 in)
Width (master or slave)	25.4 cm (10 in)
Depth	52.1 cm (20-1/2 in)

Rack-mount model

Height	26.5 cm (10-1/2 in)
Width	48.3 cm (19 in) centers
Depth	56.2 cm (22-1/8 in)

Weight

Tabletop model 22.7 kg (50 lb)

Rack-mount model

Single disk	29.5 kg (65 lb)
Dual disk	54.4 kg (120 lb)

Environment**Temperature**

Operating	10° - 40° C (50° - 104° F) ambient with a gradient of 10° C (18° F)/hr
Nonoperating (storage/shipping)	-40° - 66° C (-40° - 151° F) ambient with a gradient of 20° C (36° F)/hr

Relative humidity

Operating	10% - 90% with maximum wet bulb temperature of 28° C (82° F) and a minimum dew point of 2° C (36° F) with no condensation
Nonoperating (storage/shipping)	5% - 95% with no condensation

Altitude	
Operating	Sea level to 2.4 km (8000 ft)
	Maximum operating temperatures decrease by a factor of 1.8° C/1000 – (1° F/1000 ft) for operation above sea level.
Nonoperating (storage/shipping)	Up to 9.1 km (30000 ft) above sea level (actual or effective by means of cabin pressurization)
Shock	5 g peak at 7 – 13 ms duration in three axes mutually perpendicular (maximum)
Heat dissipation	
Single disk drive	1000 Btu/h
Dual disk drive	1850 Btu/h
Noise level (single disk)	53 dB at 1 m
Electrical	
Voltage/frequency (single phase)	90 – 128 Vac, 6 A, 47 – 83 Hz 180 – 256 Vac, 4 A, 47 – 83 Hz
Power (operating)	
Single disk	300 W
Dual disk	550 W
Line cord length (from enclosure)	2.75 m (9 ft)
Plug type	
120 Vac	NEMA 5-15P
220 – 240 Vac	NEMA 6-15P

Data Capacity (Formatted)

Single disk drive	26.061824 Mb fixed disk 26.061824 Mb removable cartridge disk 52.123648 Mb total (50,902 1Kb blocks)
-------------------	--

Dual disk drive	52.123648 Mb fixed disk 52.123648 Mb removable cartridge disks 104.247296 Mb total (101,804 1Kb blocks)
-----------------	---

Media

Fixed	One 20 cm (7-7/8 in) double-sided nonremovable disk platter per drive
-------	---

Removable	One 20 cm (7-7/8 in) double-sided disk platter in cartridge per drive
-----------	---

Seek Time

Average seek	35 ms maximum
One track seek	10 ms on same surface
Maximum seek	55 ms maximum

Latency

Speed	2850 r/min \pm 9 r/min
Average rotational latency	10.5 ms
Maximum rotational latency	21.0 ms
Average access	45.5 ms (overlapped seeks with double disk drive configuration)

Data Rates

Average long transfer rate 0.57 Mb/s typical

Spiral Read Time

Per track 31 ms typical

Per disk 50 s typical

Per drive 1 min, 40 s typical

Start/Stop Time

Start time 60 s (includes purge and self-test time)

Stop time 30 s

Safety precautions are listed with the following agencies.

UL	Underwriter Laboratories
CSA	Canadian Standards Association
VDE	Verband Deutscher Elektrotechniker (German Electrical Engineering Society)
IEC	International Electrotechnical Commission

SITE PREPARATION

This chapter contains information for preparing your computer site for the RC25 disk subsystem. When first installing the RC25 or when moving it to a different location, you must consider the following factors.

- Environment** – cleanliness, temperature, humidity, acoustics
- Power** – available voltage and current
- Space** – room for the disk drive(s)

ENVIRONMENT

The RC25 can operate in a computer room, business office, or light industry environment. Although cleanliness is important in the installation of any computer system, it is even more significant for disk drives. Read/write heads fly over the RC25 disk media in ranges of 14 to 17 millionths of an inch. Therefore, the RC25 should not be operated in an unusually contaminated atmosphere, specifically one with abrasive, airborne particles.

The most environmentally restricting part of the subsystem is its media. The operating ambient temperature range of the disk media is 10° to 40° C (50° to 104° F) with a maximum temperature gradient of 10° per hour (18° F per hour). The media's nonoperating temperature range (storage/shipping) increases to -40° to 66° C (-40° to 151° F). However, make sure the media's temperature stabilizes within the operating temperature range before use.

Humidity control is important in any computer system because static electricity can cause errors. The RC25 operates efficiently within a relative humidity range of 10 to 90 percent, with a maximum wet bulb temperature of 28° C (82° F) and a minimum dew point of 2° C (36° F). Water vapor must not condense on the disk whether or not it is operating.

Although the RC25 adds little to the noise level of the overall computer system, you may want to provide some acoustic baffling. If you use any acoustic materials, make sure they do not produce or hold dust.

Chapter 6 lists accessories for the RC25.

POWER

The RC25 operates in one of two switch selectable voltage ranges. The selection is made during installation by setting a switch at the rear of the disk drive. The low voltage range is 90 to 128 Vac single phase, and the high voltage range is 180 to 256 Vac single phase. The power frequency may be from 47 to 63 Hz. A single disk, when operating in either range, uses less than 300 W.

SPACE

The RC25 is packaged either as a standalone, tabletop unit or as a rack-mount unit for installation in a standard Digital cabinet.

The tabletop version is 25.6 cm high (10-1/8 in), 25.4 cm wide (10 in), and 52.1 cm deep (20-1/2 in) (Figure 2-1). Allow clearance at the front of the drive for inserting and removing the disk cartridge as well as cooling air inlets and outlets. Provide enough clearance at the rear of the drive for cable entry and exit, air exhaust, and access to the ON/OFF circuit breaker.

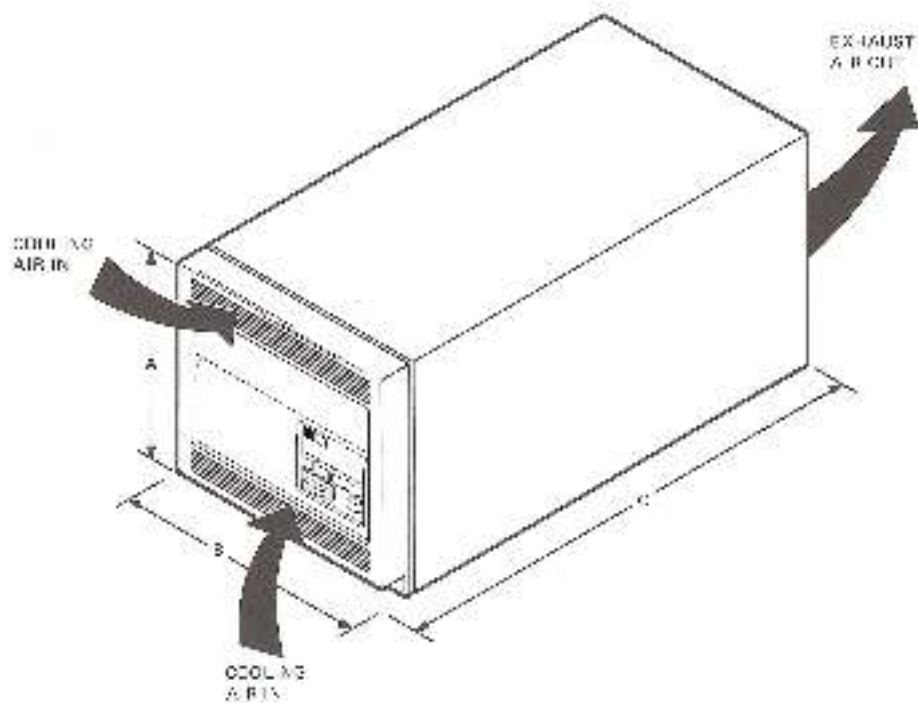

DIMENSION	CENTIMETERS	INCHES
A. HEIGHT	25.5	10.1
B. WIDTH	25.4	10.0
C. DEPTH	62.1	24.5

M-4250-06

Figure 2-1 Space Planning for the Tabletop Unit

The rack-mounted version has slides that mount on standard 48.3 cm (19 in) centers. It needs 26.5 cm (10-1/2 in) of vertical rack space and is 58.2 cm (22-1/8 in) deep (Figure 2-2). These dimensions are for the single and the dual drive configurations. You should provide space for servicing. Leave approximately 91.4 cm (36 in) at the front and rear of the cabinet so the RC25 can be extended or the cabinet door opened (Figure 2-3).

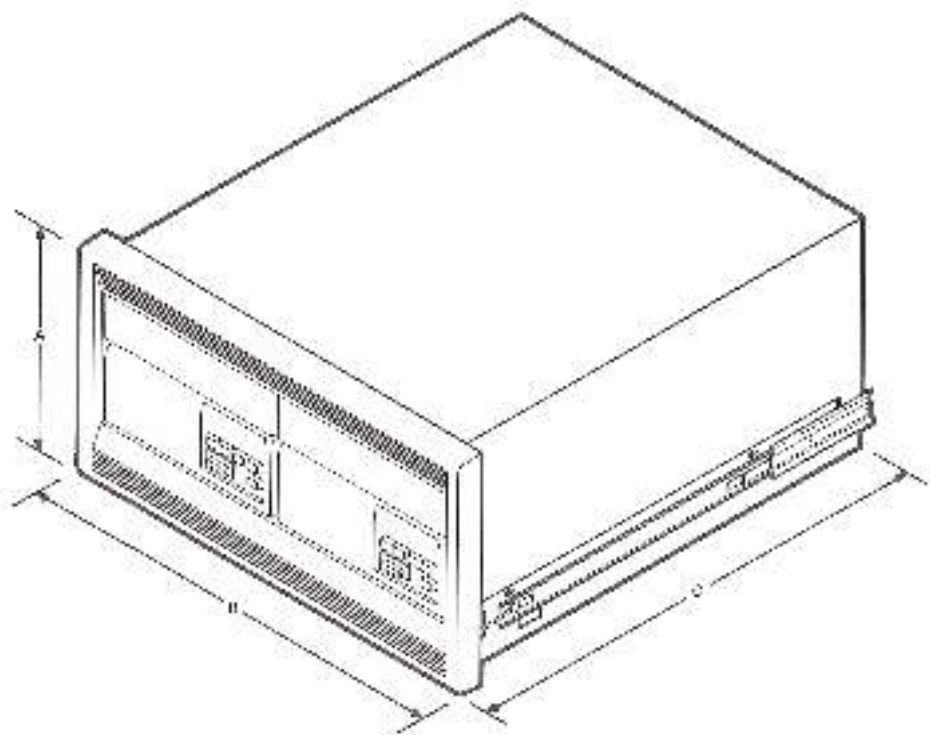

DIMENSIONS	CENTIMETERS	INCHES
A. HEIGHT	26.5	10.6
B. WIDTH	48.3	19.0
C. DEPTH	58.2	22.9

44-20142

Figure 2-2 Space Planning for the Rack-Mount Unit



DIMENSION	CENTIMETERS	INCHES
A. FRONT	91.4	36.0
B. DEPTH	7	7
C. REAR	91.4	36.0

*VARIES WITH TYPE OF CASE NET

VA-037200

Figure 2-3 Rack-Mount Unit and Service Clearances

MOVING

When moving the RC25 from one location to another, even if it is only across the room, take the following precautionary steps.

Remove the data cartridge and insert the protective, yellow shipping cartridge. The shipping cartridge was removed when the disk drive was installed. It protects the read/write heads and fixed disk platter from damage in case of bumps or excessive g forces.

*NOTE: Just insert the shipping cartridge into the cartridge receiver and close the door. Do not try to load the heads by pressing **Run**.*

After the move is complete, remove the shipping cartridge by pressing **Eject** (with power on) and store it for future use.

OPERATOR INFORMATION

The RC25 is easy to use and operate. This chapter introduces you to the operator controls and status *indicators*.

The chapter is organized in two parts. One part shows you the controls and indicators and tells their function. The other part shows how to insert and remove the disk cartridge. It also provides a complete procedure for loading/running and stopping/unloading the disk drive.

OPERATOR CONTROLS AND INDICATORS

The operator controls and indicators are at the front and rear of the tabletop model and at the front only of the rack-mounted model.

Voltage Selection

The voltage selector switch (Figure 3-1) adapts the RC25 to the available ac input voltage range. The RC25 can operate from either 120 or 220 to 240 Vac.

CAUTION: Failure to set the voltage selector switch to 230 Vac when using a 180 to 256 Vac power source damages the disk drive electronics.

To change the voltage setting, insert the tip of a ball-point pen or similar stylus in the slot and slide the switch up or down. Never use a lead pencil because the conductive graphite can get into the switch and cause a failure. Move the switch up if the RC25 is to be used in a 120 V circuit, and down for a 220 to 240 V circuit.

Turning Power On and Off

After setting the voltage selector switch and plugging the power cord into the appropriate 120/230 Vac power source (usually done during installation), you must turn on the RC25. A circuit breaker at the rear of the tabletop unit (Figure 3-1) turns the power on and off. Push the circuit breaker handle up to turn the power on and down to turn the power off. The circuit breaker must be in the on position before the RC25 can operate.

The same circuit breaker controls power to the rack-mounted unit. However, in this configuration, the circuit breaker must remain in the on position. Power to the rack-mounted unit is controlled by the computer system's master ON/OFF or I/O switch.

The circuit breaker controls the application of primary power to circuitry and the fan in the disk drive. It does not cause the *spindle motor* to spin the disk platters. The operator panel controls on the front of the RC25 perform that function.

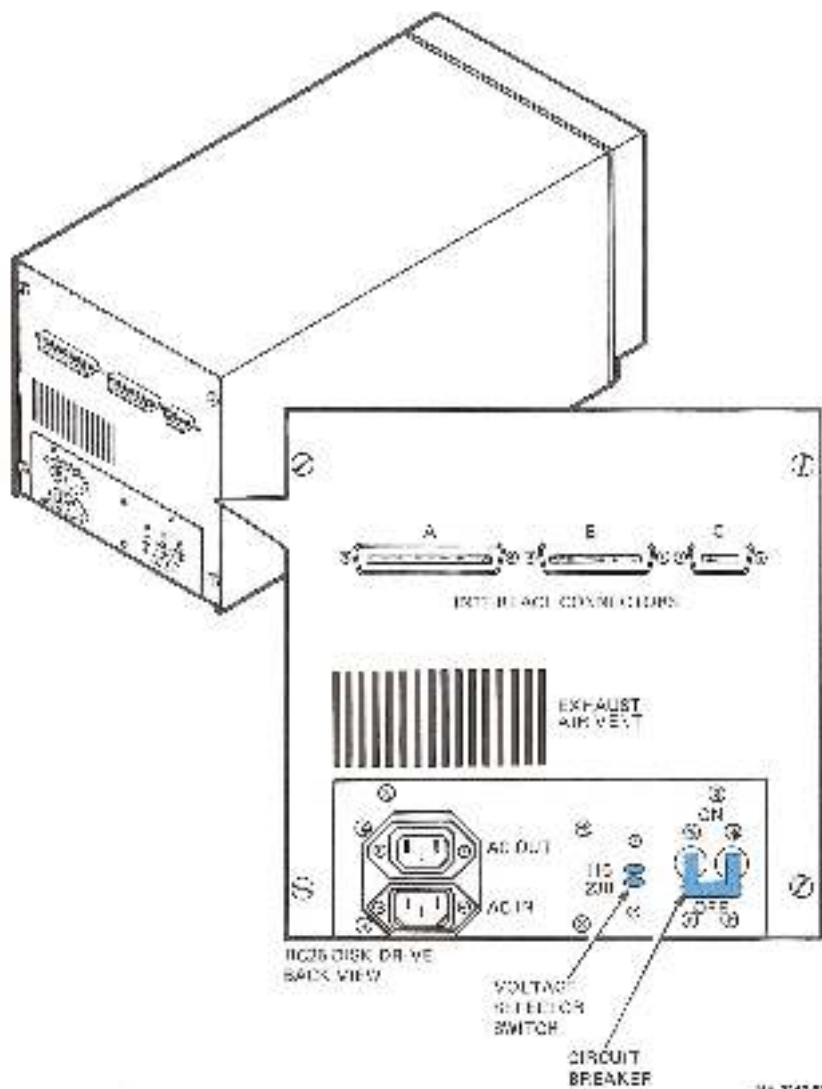

Figure 3-1 Voltage Selector Switch and ON/OFF Circuit Breaker

Operator Panel

An operator panel, located at the front lower-right corner of the RC25, contains all of the controls and visual indicators used during routine operation (Figure 3-2). The panel has five small pushbutton switches with indicators inside and a **Unit Select** number plug (Figure 3-3). The following paragraphs describe the function of each control and indicator.

Miscellaneous Indicators

Two additional visual indicators that show the status of the RC25 are behind the front bezel.

Controller Fail Indicator – The red **Controller Fail** indicator is visible through the ventilation louvers in the upper-right corner of the RC25 (Figure 3-2). In normal operation **Controller Fail** flashes on briefly when power is applied to the disk drive. If **Controller Fail** stays on when power is applied or glows during operation, a hardware failure exists in the disk subsystem.

NOTE: This indicator is on master drives only. It is not on slave drives.

Power OK Indicator – The green **Power OK** indicator is visible through the ventilation louvers in the lower-right corner of the RC25. In normal operation **Power OK** lights and remains lit when power is applied to the disk drive. If **Power OK** goes off, either a hardware failure is in the drive electronics, or the ac power to the drive was lost or is out of tolerance.

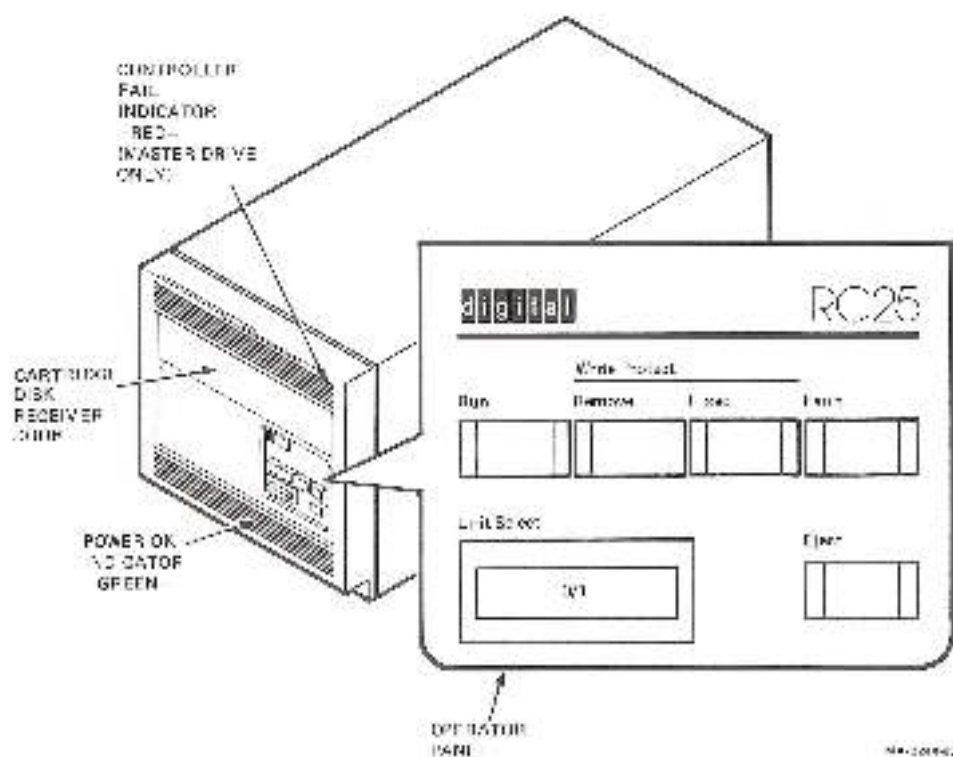

Figure 3-2 RC25 Front View Showing Operator Panel

Run (Green)

Run Button – The alternate action Run button controls the disk spin-up and spin-down sequence. When you push in Run, it latches, the cartridge receiver door locks, and the disk platters spin up to operating speed. When you press Run again, it unlatches and the disk platters spin down. The cartridge receiver door stays closed and locked until you press Eject.

The software operating system that controls disk drive operation can spin the disk platters down even though the Run button is pushed in. To override the operating system, first release and then push in Run after the spin-down command is issued.

Run Indicator – In normal operating mode the Run indicator shows the state of the disk platters. When the disk platters are at rest, Run is off and the Eject indicator is on. When the disk platters are either spinning up or down, Run flashes on and off slowly (once per second). When Run is on continuously, the disk platters are at operating speed, the read/write heads are loaded, and the drive is ready to operate.

If the disk drive detects a catastrophic hardware error, the Fault indicator lights. When you press the Fault button, the Run Indicator may or may not flash rapidly (10 times a second) depending on the fault code. Refer to the description of the Fault button/Indicator and Chapter 5 for more information about faults and fault codes.

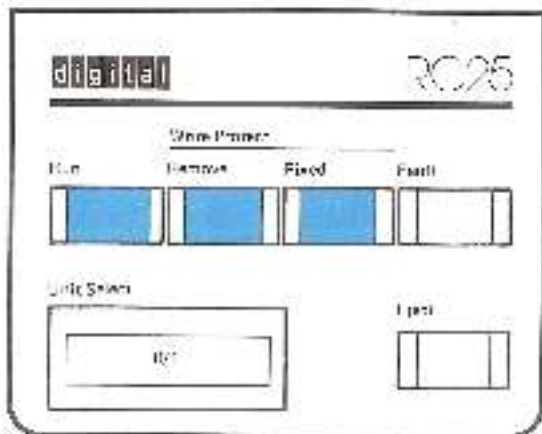

114-0214-1

Figure 3-3 Operator Panel

Write Protect (Yellow)

Write Protect Buttons – In normal operation the alternate action **Write Protect** buttons either prevent or allow writing on the disk platters. When a **Write Protect** button is pushed in and latched, the corresponding disk platter is protected and writing is not allowed. When the button is released and unlatched, writing is allowed. The **Write Protect Remove** button on the left affects the removable cartridge disk platter. The **Write Protect Fixed** button on the right affects the fixed disk platter.

The **Write Protect** buttons also determine which special test is to be executed in maintenance mode. Chapter 5 and the RC25 service documentation describe more about maintenance mode.

Write Protect Indicators – In normal operating mode, the **Write Protect** indicators show the state of the **Write Protect** buttons. When a **Write Protect** indicator is lit, the corresponding disk platter cannot be written on.

NOTE: The operating system running in the host computer can also write protect a disk platter, without regarding the button settings, and light the corresponding indicator.

If the disk drive detects a catastrophic hardware error, the **Fault** indicator lights. When you press the **Fault** button, one or both of the **Write Protect** indicators may or may not flash rapidly (10 times a second) depending on the fault code. Refer to the description of **Fault** button/indicator and Chapter 5 for more information about faults and fault codes.

Eject (Green)

Eject Button – The momentary action **Eject** button opens the cartridge receiver door so you can remove or insert a cartridge disk. When you press **Eject**, the door unlocks and the disk cartridge ejects.

Eject Indicator – The **Eject** indicator shows the state of the receiver door lock. When **Eject** is on, the door is unlocked and the **Eject** button can be pressed to insert or remove a disk cartridge. When **Eject** is off, the door is locked and the disk platters are either spun up to operating speed or in transition.

If the disk drive detects a catastrophic hardware error, the **Fault** indicator lights. When you press the **Fault** button, the **Eject** indicator may or may not flash on and off rapidly (10 times a second) depending on the fault code. Refer to the description of the **Fault** button/indicator and Chapter 5 for more information.

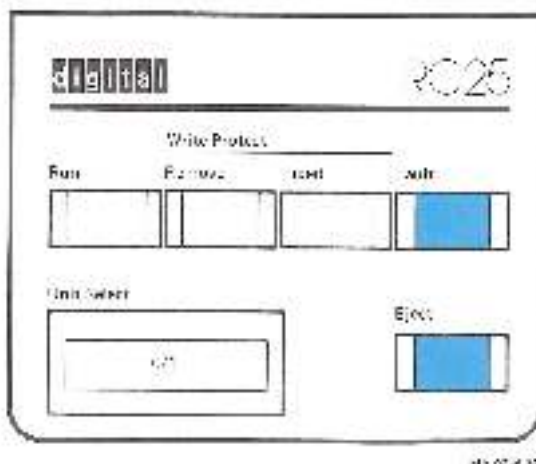

Figure 3-3 Operator Panel (Cont)

Fault (Red)

Fault Indicator – When lit continuously, the **Fault** indicator shows that the RC25 has detected a hardware error, which you may or may not be able to correct. The RC25 displays a fault code by flashing two or more of the group of five **Fault**, **Run**, **Write Protect**, and **Eject** indicators on and off rapidly. When **Fault** lights, refer to Chapter 5, which explains faults and fault codes.

Fault Button – The momentary action **Fault** button serves three purposes depending on how you use it.

When pressed briefly in response to the **Fault** indicator, the **Fault** button presents a fault code. This code is in all five of the operator panel indicators, two or more of which flash on and off rapidly. By pressing **Fault** briefly again, the RC25 tries to recover from the condition that caused the fault.

When pressed continuously for 10 or more seconds, **Fault** removes the RC25 from normal operating mode and places it in one of two maintenance test modes. The state of the two **Write Protect** buttons determines the mode. In maintenance mode, the **Fault** indicator flashes slowly and the disk does not recognize commands from the host computer system (except initialize). In this mode, all commands are issued through the operator panel by the person performing the maintenance procedure.

*NOTE: The RC25 can be placed in maintenance mode only when it is off-line to the host computer, the disk platters are spun up, and the **Fault** indicator is off.*

Chapter 5 explains more about the use of the **Fault** button and fault codes. Complete procedures for using the **Fault** button are in the RC25 technical and servicing documentation.

Indicator Function Summary

Table 3-1 shows a summary of indicator functions.

Table 3-1 Indicator States and Their Meaning					
Run	Write Protect		Fault	Eject	Meaning
	Remove	Fixed			
off	-	-	off	on	The drive is not running and the cartridge receiver door is unlocked.
slow flash*	-	-	off	off	The disk platters are spinning either up or down.
on	-	-	off	off	The drive is ready to accept commands.
-	off	-	off	-	The removable disk cartridge is write enabled.
-	on	-	off	-	The removable disk cartridge is in the read-only state. Writing is prevented.
-	-	off	off	-	The fixed disk platter is write enabled.
-	-	on	off	-	The fixed disk platter is in the read-only state. Writing is prevented.
-	-	-	on	-	The disk has detected a failure. Press Fault briefly and refer to the fault codes in Chapter 5 to determine what went wrong.
-	-	-	slow flash*	-	The drive is in maintenance mode and is running a test.

* Slow flash is once per second.

Unit Select Number

The host computer system (or computer network) locates a peripheral device via a **Unit Select** number. The RC25 can have any number pair from 0/1 to 252/253. It has a pair of numbers because both disk platters have a unique number. The removable disk platter always has an even number and the fixed disk platter always has an odd number. The **Unit Select** number is chosen during installation, but may be changed any time thereafter.

The **Unit Select** number is determined by a factory wired plug. This plug can be removed and replaced to change the number. However, the RC25 cannot function without a plug in place. The result is a fault indication. Two disk drives with the same **Unit Select** number also cause a fault.

Change the **Unit Select** number plug by grasping the plug handle (Figure 3-4) and pulling it straight out of the operator panel. Install the new number plug by pushing it straight into the empty, recessed socket. When installing the new plug, be sure to hold it so the numbers are right side up. Do not try to force an upside down plug into the socket. This mistake creates a false number and destroys the electronic components inside the operator panel.

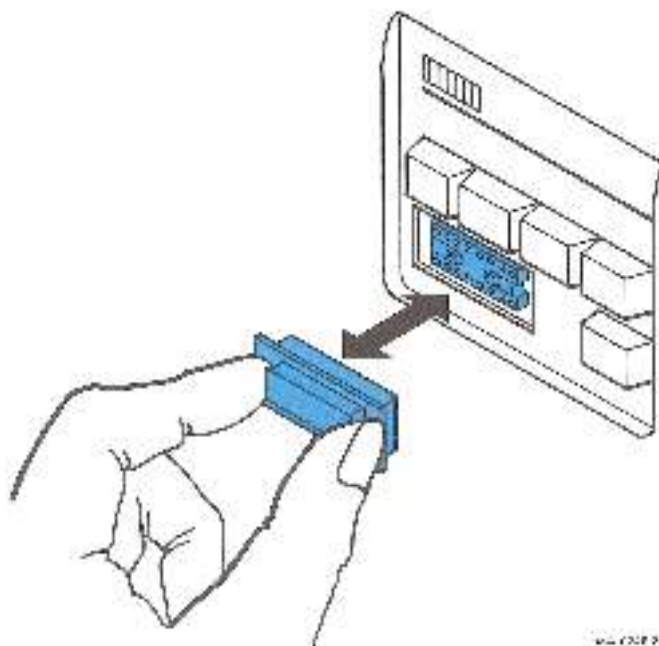

Figure 3-4 Changing the Unit Select Number Plug

Digital provides **Unit Select** number plugs for the following drive configurations.

Number	RC25
0/1	First master drive
2/3	First slave drive
4/5	Second master drive
6/7	Second slave drive

If you want to use a number greater than 7, refer to Appendix B for plug modification instructions.

Remember, whenever you change the **Unit Select** number, you must also change the host computer's operating system so the system recognizes the drive.

LOADING, UNLOADING, AND OPERATING PROCEDURES

This section tells you how to insert and remove the disk cartridge. It also provides the procedures for operating the RC25.

Cartridge Loading

The RC25 is designed to make correct loading easy. To load the cartridge disk, hold it label (writing) side up with the tapered end toward you. The opposite end has a small trap door through which the read/write heads enter. This end enters the *cartridge receiver* first (Figure 3-5).

If the cartridge receiver door is not open, press the **Eject** button. The door opens and swings down. Slide the cartridge straight in with a firm push until it locks into place. Close the receiver door firmly by swinging it back up and latching it into place.

Cartridge Unloading

Unloading the cartridge is as simple as loading. With the spindle stopped and the receiver door unlocked (**Eject** indicator on), press the **Eject** button. The door unlocks and the cartridge disk ejects. Once the door is open, grasp the cartridge and pull it straight out of the receiver.

NOTE: Keep the cartridge receiver door closed when not in use to prevent atmospheric contaminants from entering the disk enclosure.

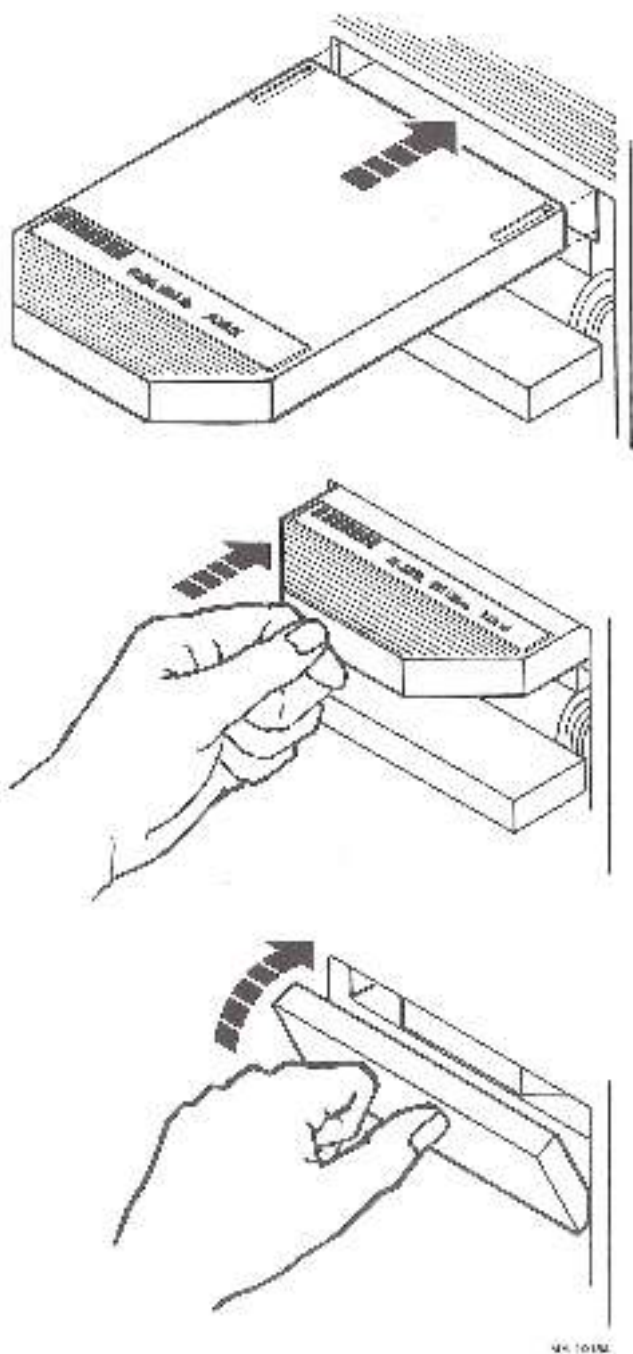

Figure 3-5 Inserting the Disk Cartridge

Disk Operating Procedures

The procedures in this section are for starting and stopping the RC25.

Starting Procedure

Operator Action	Disk Drive Response
None.	Initial state of disk drive: Run button is released (out). Run indicator is off. Eject indicator is on. Spindle is stopped.
Press Eject .	Cartridge receiver door opens and disk cartridge partially ejects.
Reload cartridge or replace with new cartridge.	None.
Close cartridge receiver door.	None.
Set Write Protect buttons.	Corresponding Write Protect indicator lights or goes off.
Press Run in to lock it in.	Receiver door locks. Eject indicator goes off. Run indicator flashes slowly. Disk platters spin up. Run indicator lights continuously.

Disk is ready for operation.

NOTE: A disk cartridge must be installed to spin up and operate the disk drive. The fixed disk does not spin-up and run without a removable cartridge in place. The spin-up cycle takes approximately 1 minute. It involves spinning the disk platters up to operating speed, cleaning the internal air system, loading the read/write heads, and performing the self-test.

Stopping Procedure

Operator Action	Disk Drive Response
None.	Initial state of disk drive: Run button is pressed in. Disk platters are spinning. Run indicator is on. Eject indicator is off.
Press Run in to release it.	Run indicator flashes slowly. Disk platters slow down. When disk platters stop spinning: Run indicator goes off. Eject indicator lights. Receiver door unlocks.
Press Eject .	Receiver door opens and disk cartridge partially ejects.
Remove disk cartridge.	
Close receiver door.	

***CAUTION:** Do not try to open the receiver door until the Eject indicator lights and the Eject button is pressed. You can damage the disk drive and cartridge.*

4

CUSTOMER CARE

This chapter explains your responsibilities for maintaining the RC25. It tells you the do's and don'ts of caring for your disk drive and media.

RESPONSIBILITIES

As the user of the RC25, it is your responsibility to make sure it is located and operated in an area that is free from excessive dust and dirt. The external surfaces of the drive should be kept clean. Also, it is your responsibility to make sure the disk cartridges are handled and stored correctly to prevent errors or data loss.

CARE OF THE DISK DRIVE

The only moving parts of the RC25 are internal and need no preventive maintenance by you. Its external surfaces can be cleaned when necessary with a nonabrasive sponge dampened with soap and water or any mild detergent. Do not use cleaners with solvents. Never clean or dust while the drive is running. Always keep the front door of the drive closed to prevent atmospheric dust and dirt from entering.

The RC25 packaging is not weatherproof; there are many filtered openings in the enclosure. Liquids can be pulled in the opening by accident due to forced air circulation. Such an incident disturbs the electronic operation of the drive and jeopardizes the integrity of data on the disk platters. For this reason, do not put drinks on top of the enclosure or use excessive water to clean the surface.

Keep the ventilation slots in the front panel and the air exhaust in the rear clear. Blocking these slots by putting an object directly in front of the drive or covering the drive during operation can cause overheating. Even worse, a read/write head to disk crash can result. A crash destroys the disk cartridge and renders the drive inoperable.

CARE OF THE DISK MEDIA

To prevent errors when recording or reading, reasonable care should be taken when handling the media. The following recommendations prevent unnecessary loss of data or interruptions of system operation.

Handling Practices and Precautions

- Allow the temperature of the disk cartridge to stabilize with the room temperature before using it. If cartridges are exposed to temperature extremes, or if the temperature differential between cartridge and drive exceeds 6° C (11° F), a 2-hour stabilization period is necessary.
- Place gummed labels only in the molded recess at the top of the disk cartridge. Labels placed on any other part of the cartridge may not remain attached and catastrophic head crashes may result.
- Do not use writing instruments that leave powder or flakes (such as lead or grease pencils) on the disk cartridge. Use a felt tip marker only.
- Do not try to access the parts inside of the cartridge or touch the disk recording surfaces.
- Do not try to clean the disk platter surface in any way.
- A sustained tinging, scratching, or rumbling sound that is a result of head to disk contact can occur if excessive contamination is in the drive or cartridge. This sound can also occur if the drive or cartridge is defective. If you hear this sound, stop the drive immediately to prevent further damage and remove the disk cartridge. If you have doubts about the functional condition of either a cartridge or drive, call trained service personnel.

CAUTION: Do not try to load the cartridge on another drive until you are sure that the media is not damaged or contaminated. Otherwise, you may damage the read/write heads on the other drive.

Do not operate the suspected drive with another cartridge until you are sure the read/write heads are not damaged or contaminated. Otherwise, you may damage another cartridge.

Storage

- Store cartridges in a clean, dry area away from radiant heat and direct sunlight.
- Whenever a cartridge is not installed in a drive, enclose it in a sealed container to exclude dust and dirt.
- Do not store cartridges on top of a computer cabinet that has a top air intake or exhaust or in places where dirt can be blown by fans into the cartridge.
- Keep the cartridge away from magnets or magnetized tools. Any disk exposed to a magnetic field can lose information.
- Do not place heavy items on top of the disk cartridge.
- Store cartridges on edge or stacked. However, when stacking cartridges, do not stack more than five high.

SOLVING PROBLEMS

The RC25 contains a set of hardware *diagnostic* programs that check its major functions. If there is a malfunction, the applicable diagnostic program identifies where or what the problem is. The program sends an error/status code to the host computer or a fault code to you through the indicators.

This chapter tells you what to do if you have a problem with the RC25. The chapter is divided into four sections. The first section has a troubleshooting chart that lists some of the problems and the steps you take to correct them. The second section defines the fault codes so you can detect a possible operator error or hardware failure. The third section has procedures to verify that the RC25 is operating correctly, in case another part of the system is causing the problem. The fourth section explains your options for servicing a malfunction if it cannot be remedied immediately.

IDENTIFYING AND CORRECTING PROBLEMS

Table 5-1 lists some of the symptoms, causes, and solutions for troubleshooting the RC25. To use the table, take the following steps.

1. Determine what the RC25 is or is not doing.
2. Match your symptom with one in the first column. The most probable symptoms are listed first.
3. Check the conditions listed in the second column.
4. Follow the advice given in the third column.

Table 5-1 Isolating and Correcting Problems

Symptom	Cause	Solution
There is no power. Power OK indicator is not on (Figure 3-2). Eject indicator is not on when you first turn on power.	Dead socket	Check ac power by plugging in and turning on a lamp.
	Power cord connections	Check power cord connection at wall and at drive.
	Tripped circuit breaker (off)	Set circuit breaker at rear of drive to OFF, then ON.
Power OK and Eject indicators are on, but cartridge receiver door does not open when Eject button is pressed.	Wrong voltage selector switch setting	Determine available line voltage and set switch accordingly.
	Electrical or mechanical malfunction	Refer to "Servicing Options."
Controller Fail indicator remains on.	Electrical malfunction	Refer to "Servicing Options."
Fault indicator is on.	One of many	Refer to "Faults and Fault Codes."

Table 5-1 Isolating and Correcting Problems (Cont)

Symptom	Cause	Solution
Abnormal noises are coming from inside drive.	Mechanical malfunction or head to disk platter crash	Stop drive immediately. Do not try another cartridge in this drive and do not try to insert this cartridge in another drive. Refer to "Servicing Options."
Excessive data errors occur when reading or writing.	Damaged or dirty disk platter	Try another cartridge.
	Mechanical or electrical malfunction	Refer to "Servicing Options."
	Incorrectly stored or handled disk cartridge	Refer to Chapter 4.
Host computer system cannot access disk.	Interface cable connections	Check cable connections at drive(s) and at computer.
	Wrong Unit Select number	Make sure Unit Select number plug matches number specified in host computer software.

FAULTS AND FAULT CODES

This section tells you how to interpret some of the fault codes and relate them to the source of a problem.

NOTE: Some fault codes relate to problems you may not be able to solve, such as a defective circuit module. For a complete list of all RC25 fault codes, refer to servicing documentation.

Hard failures in the disk subsystem can present themselves in one of three ways or in combinations of all three. Two ways, described here, are through the **Controller Fail** indicator and the various user-correctable fault codes. The third way is through a system error message displayed on your terminal. Refer to the documentation included with your system to interpret error messages.

Controller Fail Indicator

The red **Controller Fail** indicator is visible through the ventilation louvers in the upper-right corner of the RC25 (Figure 5-1). In normal operation **Controller Fail** flashes on briefly when power is applied to the RC25. If **Controller Fail** stays on when power is applied or lights during operation, a hardware failure is in the drive electronics. There is no recovery from this failure. Refer to "Servicing Options" to resolve this problem.

*NOTE: The **Controller Fail** indicator is on master drives only, not slave drives.*

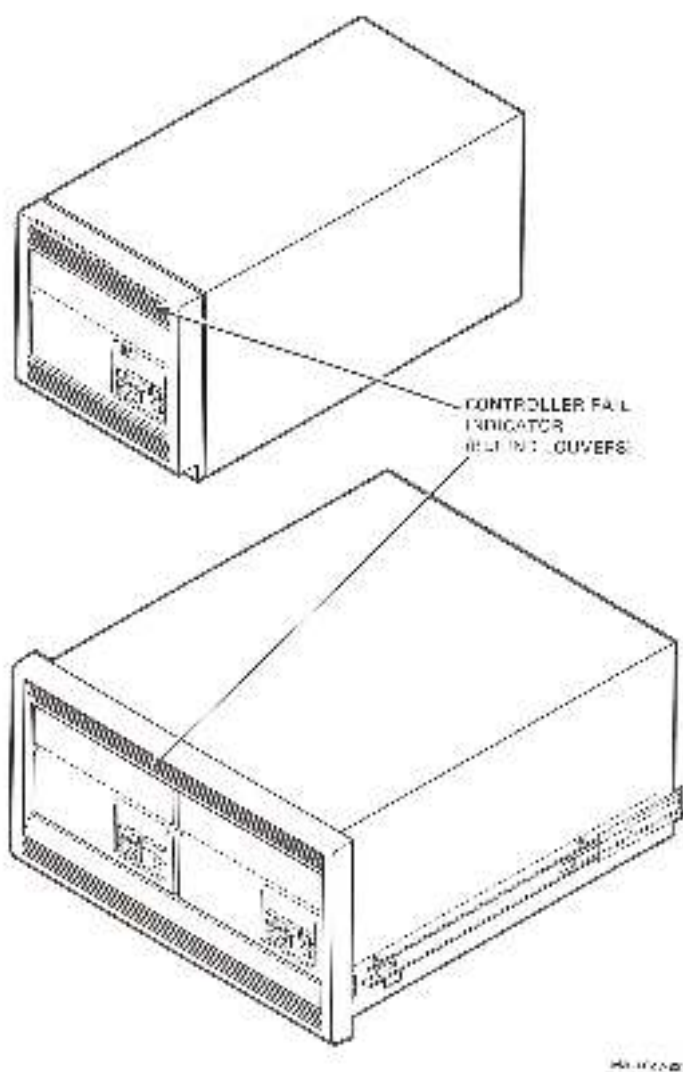

Figure 5-1 Controller Fail Indicator

Fault Indicator

When the RC25 detects an error, the **Fault** indicator lights (Figure 5-2). Most errors have fault codes. Press the **Fault** button to display the fault code. The code appears in all five of the operator panel indicators. Some or all of the indicators flash rapidly (approximately 10 times per second).

The following figures show you the fault codes for problems that you can fix yourself: incorrect configurations, bad disk media, some types of software errors, and power problems.

Any fault code not listed here indicates a hardware or software problem in the disk subsystem. These problems require the service of experienced hardware or software personnel. Refer to "Servicing Options" to resolve these problems.

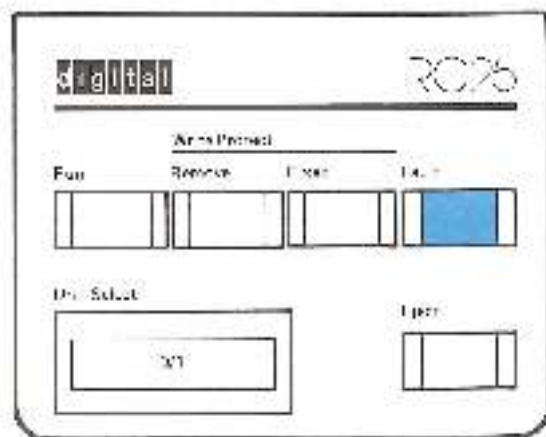

6-11702-02

Figure 5-2 Fault Indicator

Fault Code 11: Interface Cable

Fault code 11 (Figure 5-3) indicates a problem with the interface cable going from the host computer to the drive.

A possible solution is to tighten the cable connector retaining screws at the host computer and the drive. The cable may be loose.

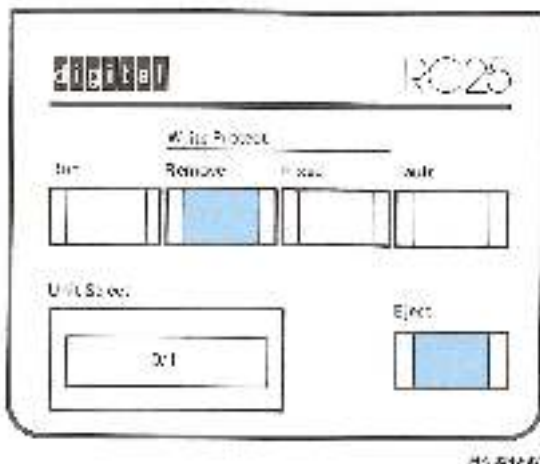

Figure 5-3 Fault Code 11: Interface Cable



Fault Codes 12 and 13: Software

Fault codes 12 (Figure 5-4) and 13 (Figure 5-5) indicate an error with the operating system software (I/O driver) that allows the host computer to send and receive data and commands to and from the RC25.

Try rebooting or reloading the operating system into the host computer to clear the error.

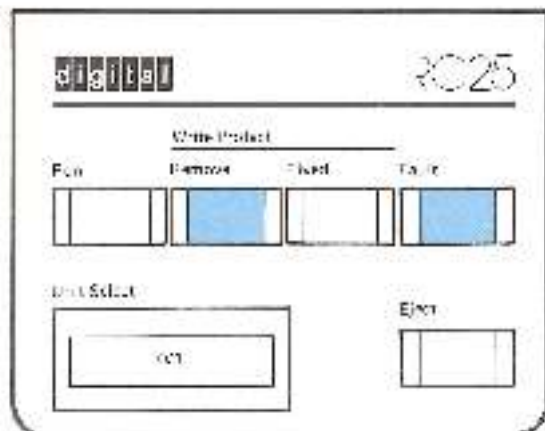

24-04-11

Figure 5-4 Fault Code 12: Software

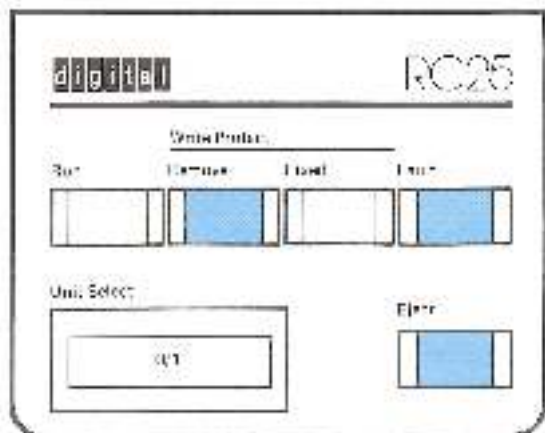

24-04-11

Figure 5-5 Fault Code 13: Software

Fault Code 14: AC Line Voltage

Fault code 14 (Figure 5-6) indicates that the drive or the host computer has detected a fluctuation or dropout in the incoming line voltage. If you do not know that a power outage has occurred, have a qualified electrician check the power line integrity.

Fault code 14 also indicates a marginal component in the power supply. If this is the case, the drive must be repaired by qualified service personnel. Refer to "Servicing Options."

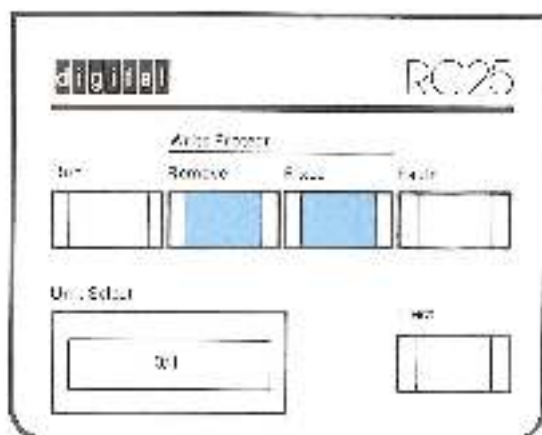

Figure 5-6 Fault Code 14: AC Line Voltage



Fault Code 15: Temperature

Fault code 15 (Figure 5-7) means that the drive's thermal sensors detect a temperature inside the enclosure that exceeds the specified limits during operation. To avoid serious damage to the drive, safety circuits unload the read/write heads and stop the disk platters until the temperature drops to within limits.

Make sure the air temperature in the room where the drive is operating is within the allowable range, 10° - 40° C (50° - 104° F).

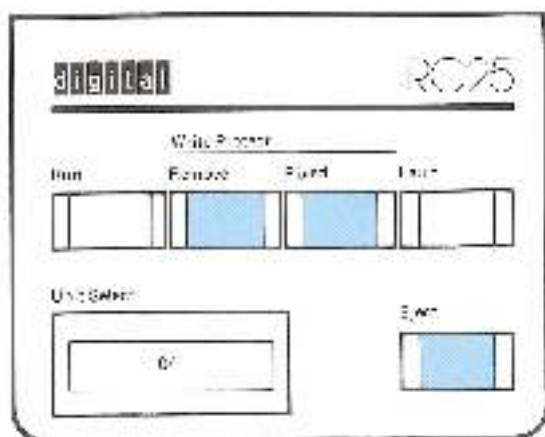

0000000

Figure 5-7 Fault Code 15: Temperature

Fault Code 16: Unit Select Number

Fault code 16 (Figure 5-8) indicates that two or more drives have the same **Unit Select** number plugs. Each drive must have a unique unit number pair. Therefore, you must change the **Unit Select** number plug on one or more of the drives in the system.

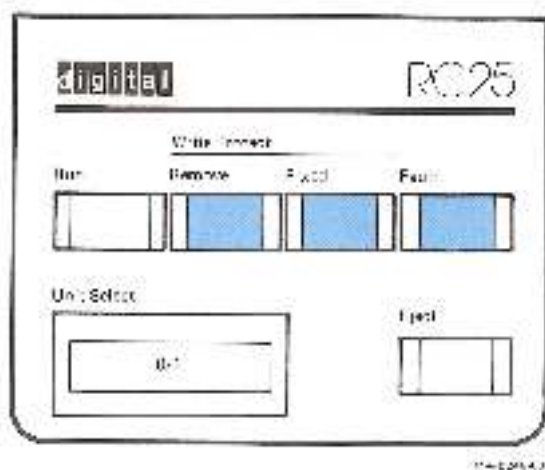

Figure 5-8 Fault Code 16: Unit Select Number



Fault Codes 30, 31, and 32: Disk Format

Fault code 30 (Figure 5-9), 31 (Figure 5-10), or 32 (Figure 5-11) appears when the drive detects an error while reading the coded formatting information on the disk platters.

Try another disk cartridge; the cartridge you are using may have an unrecoverable format error. This solution does not always work, however, because these codes also indicate a format error on the fixed disk platter. If a different cartridge does not produce better results, call service personnel to resolve the problem.

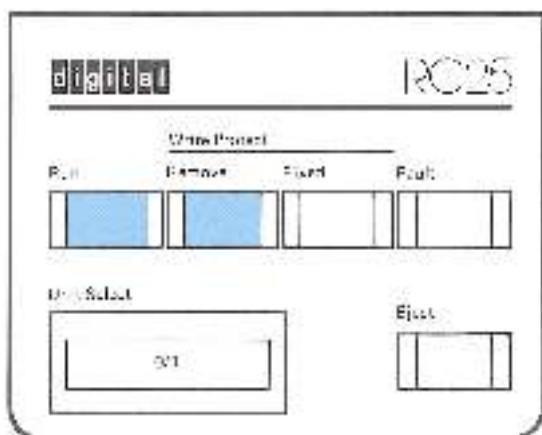

44-249-02

Figure 5-9 Fault Code 30: Disk Format

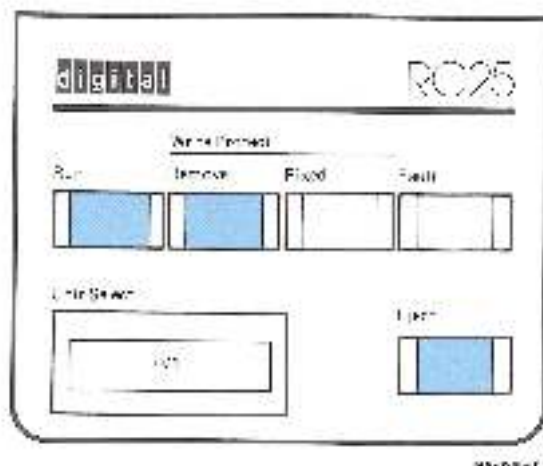

Figure 5-10 Fault Code 31: Disk Format

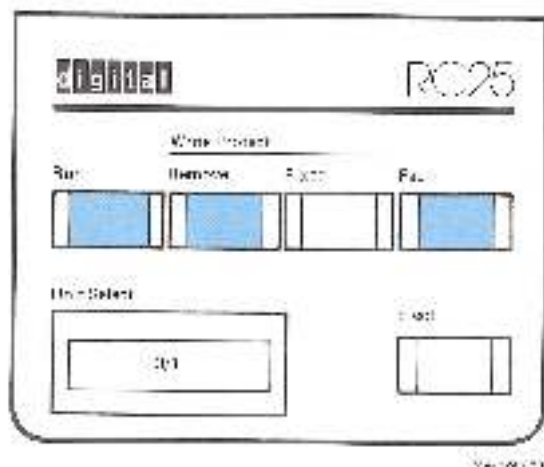



Figure 5-11 Fault Code 32: Disk Format

 Flashing

 Off

VERIFICATION TESTS

This section has procedures for verifying correct drive operation. Use the verification tests if you experience disk related problems, but receive no firm failure indication as when the **Fault** indicator lights. Follow the steps in sequence. If the **Fault** indicator remains on during a test, the drive has a failure and the fault code should be read. (Refer to "Faults and Fault Codes.")

Test 1: Power-On Check

1. Eject and unload any disk cartridges.
2. Remove power from all drives by setting the ON/OFF circuit breaker at the rear of the enclosure to OFF (Figure 3-1). For rack-mounted drives, turn the system power off.
3. Turn the power back on. (Set the circuit breaker to ON or system power on.)
4. The RC25 enters a short diagnostic test as soon as power is applied. When the test is complete and if the drive is working, the status of the indicators (Figure 3-2) is as follows.

Controller Fail (red) should be off (master drives only).

Power OK (green) should be on.

Eject (green) should be on.

NOTE: A portion of this diagnostic test causes all of the indicators to light momentarily. This brief indicator flash is acceptable and should not be considered a failure.

5. Continue to test 2 if these three indicators show that the drive is working so far. If not, a hardware problem exists. If the **Fault** indicator is on, refer to "Faults and Fault Codes." Refer to "Servicing Options" for servicing information.

Test 2: Disk and Head Load Check

Perform this test after the drive passes the power-on check.

1. Press the **Eject** button. The receiver door opens.
2. Load a disk cartridge in the drive through the open receiver door.
3. Close the receiver door.
4. Press the **Run** button in and lock it. This step causes five things to happen, during which the **Run** indicator flashes slowly (once per second).
 - a. The cartridge receiver door locks.
 - b. The disks spin up to speed.
 - c. The internal filtration system enters a purge cycle. (It cleans the internal air system.)
 - d. The head/actuator mechanism enters a quick diagnostic test.
 - e. The heads load onto the disk platters.
5. At the completion of the spin-up cycle, the **Run** indicator stops flashing and stays on. The **Fault** indicator should stay off. If these conditions exist, continue to test 3. If not, refer to "Servicing Options" for servicing information.

Test 3: Quick Verification

Perform this test after the drive passes the power-on check and head load test.

1. With the disks spinning, heads loaded, and **Run** indicator on, press in and lock the **Write Protect Fixed** button and the **Write Protect Remove** button. Both **Write Protect** indicators should light.
2. Press the **Fault** button and hold it in for a minimum of 10 seconds. After 10 seconds, the **Fault** indicator flashes slowly. Then you can release the **Fault** button.
3. Step 2 starts the quick-verify diagnostic test, which runs about 8-1/2 minutes. During the test, the **Fault** indicator flashes slowly, indicating that the test is still in progress. You can stop the test before it finishes by releasing the **Write Protect Remove** button.
4. The test does the following things.
 - a. Performs random writes and reads on reserved diagnostic areas on the inside and outside tracks of all disk surfaces.
 - b. Performs random read/write head seeks.
 - c. Measures the integrity of the read/write and servo systems by measuring how far the heads can move away from the center of the data track and still read the data that resides there.
 - d. Measures the cartridge mechanical runout.
 - e. Measures the signal to noise ratio on the servo track position samples.
5. The test signals completion by running the power-on check and turning off the **Fault** indicator (normal operating state). The test should run without any failures. If a failure does occur, the **Fault** indicator stops flashing and remains on. Press the **Fault** button to read the fault code.

Test 4: Extended Verification

The quick-verify test can be run continuously. That is, it can run forever until commanded to stop. Running the test for long periods may be necessary to uncover subtle or intermittent problems. You can demonstrate the integrity of the drive by running it overnight.

1. Test 4 starts the same way as in step 3 of test 3, except for the position of the two **Write Protect** buttons. Press in and lock the **Write Protect Remove** button and release the **Write Protect Fixed** button. The **Write Protect Remove** indicator should light and the **Write Protect Fixed** indicator should go off. Then press in and hold the **Fault** button for 10 seconds.
2. Stop the extended-verify test by releasing the **Write Protect Remove** button.

SERVICING OPTIONS

In most cases, you should maintain the RC25 the same way you maintain its host computer. For this reason, contact the person responsible for maintaining the system (system manager) to determine the correct method. Your options are as follows.

Digital Field Service

Digital offers a wide range of services. "Support Services" in Chapter 6 lists them. If you need Digital service for warranty, contract, or time and materials (per call) maintenance, call the Digital Field Service office nearest you.

Self-Maintenance

Digital offers a full line of support products for self-maintenance customers including service documentation and spare parts kits. If your RC25 is out of warranty and your organization performs its own corrective maintenance, contact the person who is responsible for maintaining your computer system.

ACCESSORIES, SUPPLIES, AND SERVICES

A wide range of accessories, supplies, and services are available to make operating the RC25 easier. The following paragraphs describe the accessories, supplies, and ordering procedures. A description of the many support services that are available is also provided.

SPARE PARTS AND DOCUMENTATION

The Customer Spares organization at Digital provides support in the following areas.

- Spare inventory planning
- Maintenance test equipment
- Documentation
- Emergency spare parts

An RC25 spare parts kit for self-maintenance customers is available by ordering part number 4A-RQC25-00 for LSI-11 bus systems or 4A-RUC25-00 for UNIBUS based systems.

For a list of documentation supporting the RC25, refer to Table 1-2.

ORDERING INFORMATION

Table 6-1 lists the accessories and supplies you can order for your RC25.

Table 6-1 Accessories and Supplies	
Part Number	Description
RC25K-DC	<p>This 25-megabyte, front-loading disk cartridge is manufactured by Digital under strict quality control. The disk cartridge has one platter with two recording surfaces. The platter is enclosed in an impact resistant cartridge that provides protection from dust and other contaminants.</p> <p>All disk cartridges are sent pre-formatted for Digital systems. Bad blocks are pre-initialized during manufacturing to ensure that all data areas marked as good can be recorded on and read by any drive.</p>
H9650-AP	Media Mate shelf or file storage cart with casters and lockable drawer for storing disk cartridges. measures 64.1 cm high (25.25 in), 38.1 cm deep (15 in), 17.0 cm wide (6.7 in).
H950-DA	Antistatic floor mat, DECmat, 122 cm x 183 cm (4 ft x 6 ft), driftwood color (brownish gray).
H950-DB	Antistatic floor mat, DECmat, 122 cm x 183 cm (4 ft x 6 ft), summer earth color (brown/gold).
H950-DC	Antistatic floor mat, DECmat, 91 cm x 305 cm (3 ft x 10 ft), silver birch color (silver-gray/brown).
H950-DD	Antistatic floor mat, DECmat, 91 cm x 305 cm (3 ft x 10 ft), autumn bronze color (orange/brown).
H950-DE	Antistatic floor mat, DECmat, 91 cm x 305 cm (3 ft x 10 ft), driftwood color (brownish gray).
H950-DF	Antistatic floor mat, DECmat, 122 cm x 183 cm (4 ft x 6 ft), silver birch color (silver-gray/brown).
H950-DH	Antistatic floor mat, DECmat, 122 cm x 183 cm (4 ft x 6 ft), autumn bronze color (orange/brown).

Call or mail DECdirect to order supplies, accessories, documentation, and spares kits.

Phone

Orders are processed immediately.

Continental US

8:30 a.m. to 6 p.m. (EST)

(800)-258-1710

New Hampshire, Alaska, or Hawaii

8:30 a.m. to 6 p.m. (EST)

(603)-884-6660

Mail

Same-day shipment upon receipt of order.

Digital Equipment Corporation

Accessories and Supplies Group

P.O. Box CS2008

Nashua, New Hampshire 03061

Terms and conditions include net 30 days and F.O.B. Digital plant. Orders under \$35.00 need to be prepaid. Check, money order, VISA, and MasterCard are accepted. Checks and money orders should be made out to Digital Equipment Corporation.

Information concerning microfiche libraries can be obtained at the following address.

Digital Equipment Corporation

Micropublishing Group (BUO/E46)

12 Crosby Drive

Bedford, Massachusetts 01730

SUPPORT SERVICES

A wide range of maintenance and customer services are available from Digital to support your computer system. Depending on the type of equipment, you can select an alternative that meets your service needs from complete Digital maintenance to complete self-maintenance.

Five service groups are dedicated to meeting the post-sales service needs of RC25 customers. The following paragraphs describe them.

Field Service

This organization provides customers with on-site maintenance service through a wide range of service products. There are over 350 service locations worldwide with over 6000 service personnel dedicated to servicing Digital equipment.

On-Site Service

A variety of contractual on-site service programs is available for the RC25 and complete computer systems. Per-call service is also available in which maintenance is provided on a time and material basis.

Customer Spares

Customer Spares sells spare parts to customers who want to perform any level of self-maintenance. Customers in remote locations or with high uptime requirements and who use the Field Service organization can benefit from the services offered by this organization. Services offered by Customer Spares, plus educational courses, make it possible for the customer to be successful at self-maintenance.

Educational Services

Through the Educational Services group, customers can be trained from introductory to state-of-the-art in software, hardware, and system management. Courses are offered at worldwide locations and at the customer's site.

Software Services

Software Services is dedicated to supporting Digital software by providing software consulting, maintenance, and components to customers. Over 2000 software specialists are located worldwide to help you with your software needs.



PROGRAMMER INFORMATION

The RC25 operates under the Digital standard mass storage control protocol (MSCP). The rules for MSCP are defined in the *MSCP Basic Disk Functions Manual (AA-L619A-TK)*. Drives that interface to the UNIBUS (RUC25 series) or LSI-11 bus (RQC25 series) abide by the Digital standard UNIBUS/Q-bus storage systems protocol also. This protocol is defined in the *Storage System UNIBUS Port Description (AA-L621A-TK)*. Both documents can be purchased from the following address.

Software Distribution Center
Order Administration/Processing
20 Forbes Road (NR4)
Northboro, Massachusetts 01532

The RC25 abides by both specifications. However, these specifications allow for optional features or features that can be implemented in many ways. The following paragraphs provide information specific to the RC25 and are necessary for writing software for the RC25 subsystem.

UNIBUS/LSI-11 PORT INFORMATION

- The I/O page address assigned to the first RC25 initialization and polling (IP) register is 172150₈ (F468₁₆). Use word mode transfers to this register.
- The I/O page address assigned to the first RC25 status, address, and purge (SA) register is 172152₈ (F46A₁₆). Use word mode transfers to this register.
- Interrupts on UNIBUS systems are allowed at levels BR5 or BR4 only. Interrupts are not allowed at levels BR7 or BR6. The UNIBUS adapter is factory set to BR5.
- Interrupts on LSI-11 bus systems are allowed at level BR4 only. The LSI-11 bus adapter is factory set to BR4 (BIRQ4).
- For step 1 read data, the RC25 does not return the no vector (NV) bit. The RC25 supports a host-settable interrupt vector address. A vector address of 154₈ (8C₁₆) is assigned to the RC25.
- For step 4 write data, the RC25 ignores the burst field. The RC25 implements burst sizes according to the host bus type.
- The RC25 fully supports 22-bit addressing on corresponding LSI-11 systems. The RC25 returns the Q-bus (LSI-11 or QB) bit in step 1 read data.
- Host bus access errors are fatal to the RC25 if the error occurs on the ring descriptors or ring entries. The SA register returns an error code and the virtual circuit is broken.
- The RC25 fully implements the wrap and purge/poll diagnostics. The RC25 returns the enhanced diagnostics (DI) bit in step 1 read data.

MSCP INFORMATION

- The RC25 does not support multiple host processors.
- The RC25 does not perform disk shadowing.
- The RC25 does not support caching.
- The RC25 has a command limit value of 14. This limit includes 14 MSCP commands plus 1 immediate-only command. No special actions are taken when the command limit is reached. The RC25 does not accept any subsequent commands until a command slot becomes available. The command that exhausts command slots is not checked to be an immediate command. The RC25 controller does not go Controller Available.
- The receipt of an invalid command from the host does not make the RC25 Controller Available.
- The DETERMINE ACCESS PATHS command is treated as a no operation (NOP).
- The ACCESS PATH attention message is never generated.
- The ABORT command can only abort queued commands, never an active command.
- The following commands are treated as immediate NOPs. No parameter checking or execution sequencing is performed.

COMPARE CONTROLLER DATA
 DETERMINE ACCESS PATHS
 FLUSH

- The DEVICE DEPENDENT PARAMETERS field of the ONLINE and SET UNIT CHARACTERISTICS command has one bit defined (LSB) and signifies Show All Errors. Normally, the RC25 does not issue error log messages for ECC corrections that have less than a threshold number of errors. Setting this bit requests that the RC25 report all errors.

- The RC25 does not validate command modifier legality, but does support modifiers legal for a specific command.
- The RC25 supports only 512-byte disk sector formats, not 576-byte sectors.
- Replacement and caching table (RCT) references can use byte counts other than 512 bytes. However, any host transfer that crosses from the normal logical block number (LBN) space into the RCT area is flagged as an invalid command.
- The RC25 does not do controller-initiated, bad block replacement and does not return Serious Exception.
- The controller timeout value is 15 seconds and the default host access timeout is 60 seconds. The controller supports host access timeouts in the range of 0 to 255 seconds. All time units can have an error tolerance of 0 to -100 percent.
- Host bus errors, except host bus parity errors, are retried for references to I/O buffers. Any host bus error to either the rings or the ring descriptor registers results in the controller going Controller Available and is not retried.
- Byte count values that exceed either disk capacity or the host memory are not detected until the boundary is crossed.
- The RC25 returns error log messages to the host with a zero sequence number and the sequence number reset flag. RC25 generates, at most, three error log messages per command, regardless of the number of retries needed to complete the command. The error log information reflects the first error encountered of a certain type.
- The RC25 uses the small disk errors format of log messages, not the standard disk interface (SDI) errors format.

- The RC25 ignores or never returns the following unit flags.

- Controller Initiated Bad Block Replacement
- Inactive Shadow Set Member
- Suppress Caching
- Write Back
- 576-Byte Sectors

- The RC25 ignores or never returns the following controller flags.

- Enable Other Host's Error Log Messages
- Multi-Host
- Shadowing
- 576-Byte Sectors

B

HOW TO MODIFY THE UNIT SELECT NUMBER PLUG

If you want to use a **Unit Select** number pair of 8/9 or higher for your RC25, you must open and modify the **Unit Select** number plug. The procedure in this appendix shows you how to make the modification.

1. Remove the plug on the operator panel by grasping the plug handle and pulling it straight out.
2. The plug contains a small, seven-position DIP switch. Remove this switch from the handle by pressing the two plastic retaining tabs and pulling straight out.
3. When working with the switch, orient it so that the small notch and the number 1 position is on the right (Figure B-1).

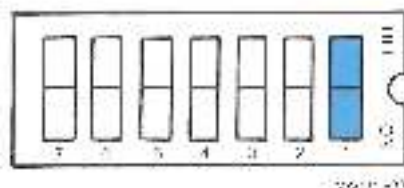
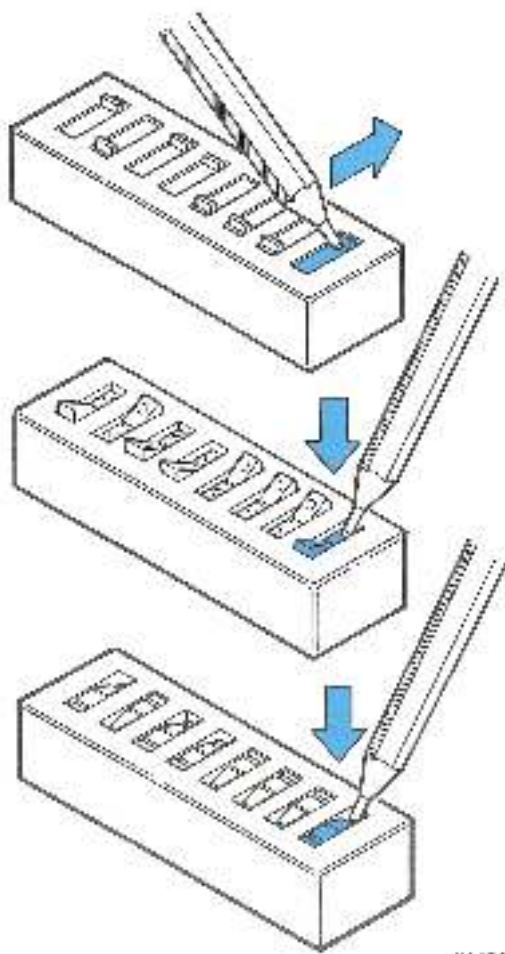

Figure B-1 Unit Select Number Switch

4. Find the number pair you want from Table B-1 and set the seven switches as indicated. Three different types of switches are used in the RC25: one slide switch and two types of rocker switch (Figure B-2). It is important to identify which type of switch your drive has before trying to change the number. To change the number with a slide switch, push the switch tab to OFF or ON (up or down) as indicated in the table. To change the number with a rocker switch, press in on the corresponding side of the switch.
5. After setting the new number, press the DIP switch back into the plug handle and insert the plug back in the operator panel.



B-124

Figure B-2 Setting the Unit Select Number Switch

Table B-1 Unit Select Number Switch Settings

Unit Number	DIP Switch Position Number						
	7	6	5	4	3	2	1
0/1	off	off	off	off	off	off	off
2/3	off	off	off	off	off	off	on
4/5	off	off	off	off	off	on	off
6/7	off	off	off	off	off	on	on
8/9	off	off	off	off	on	off	off
10/11	off	off	off	off	on	off	on
12/13	off	off	off	off	on	on	off
14/15	off	off	off	off	on	on	on
16/17	off	off	off	on	off	off	off
18/19	off	off	off	on	off	off	on
20/21	off	off	off	on	off	on	off
22/23	off	off	off	on	off	on	on
24/25	off	off	off	on	on	off	off
26/27	off	off	off	on	on	off	on
28/29	off	off	off	on	on	on	off
30/31	off	off	off	on	on	on	on
32/33	off	off	on	off	off	off	off
34/35	off	off	on	off	off	off	on
36/37	off	off	on	off	off	on	off
38/39	off	off	on	off	off	on	on
40/41	off	off	on	off	on	off	off
42/43	off	off	on	off	on	off	on
44/45	off	off	on	off	on	on	off
46/47	off	off	on	off	on	on	on
48/49	off	off	on	on	off	off	off
50/51	off	off	on	on	off	off	on
52/53	off	off	on	on	off	on	off
54/55	off	off	on	on	off	on	on
56/57	off	off	on	on	on	off	off
58/59	off	off	on	on	on	off	on
60/61	off	off	on	on	on	on	off
62/63	off	off	on	on	on	on	on
64/65	off	on	off	off	off	off	off
66/67	off	on	off	off	off	off	on
68/69	off	on	off	off	off	on	off

Table B-1 Unit Select Number Switch Settings (Cont.)

Unit Number	DIP Switch Position Number						
	7	6	5	4	3	2	1
70/71	off	on	off	off	off	on	on
72/73	off	on	off	off	on	off	off
74/75	off	on	off	off	on	off	on
76/77	off	on	off	off	on	on	off
78/79	off	on	off	off	on	on	on
80/81	off	on	off	on	off	off	off
82/83	off	on	off	on	off	off	on
84/85	off	on	off	on	off	on	off
86/87	off	on	off	on	off	on	on
88/89	off	on	off	on	on	off	off
90/91	off	on	off	on	on	off	on
92/93	off	on	off	on	on	on	off
94/95	off	on	off	on	on	on	on
96/97	off	on	on	off	off	off	off
98/99	off	on	on	off	off	off	on
100/101	off	on	on	off	off	on	off
102/103	off	on	on	off	off	on	on
104/105	off	on	on	off	on	off	off
106/107	off	on	on	off	on	off	on
108/109	off	on	on	off	on	on	off
110/111	off	on	on	off	on	on	on
112/113	off	on	on	on	off	off	off
114/115	off	on	on	on	off	off	on
116/117	off	on	on	on	off	on	off
118/119	off	on	on	on	off	on	on
120/121	off	on	on	on	on	off	off
122/123	off	on	on	on	on	off	on
124/125	off	on	on	on	on	on	off
126/127	off	on	on	on	on	on	on
128/129	on	off	off	off	off	off	off
130/131	on	off	off	off	off	off	on
132/133	on	off	off	off	off	on	off
134/135	on	off	off	off	off	on	on
136/137	on	off	off	off	on	off	off
138/139	on	off	off	off	on	off	on

Table B-1 Unit Select Number Switch Settings (Cont)

Unit Number	DIP Switch Position Number						
	7	6	5	4	3	2	1
140;141	on	off	off	off	on	on	off
142;143	on	off	off	off	on	on	on
144;145	on	off	off	on	off	off	off
146;147	on	off	off	on	off	off	on
148;149	on	off	off	on	off	on	off
150;151	on	off	off	on	off	on	on
152;153	on	off	off	on	on	off	off
154;155	on	off	off	on	on	off	on
156;157	on	off	off	on	on	on	off
158;159	on	off	off	on	on	on	on
160;161	on	off	on	off	off	off	off
162;163	on	off	on	off	off	off	on
164;165	on	off	on	off	off	on	off
166;167	on	off	on	off	off	on	on
168;169	on	off	on	off	on	off	off
170;171	on	off	on	off	on	off	on
172;173	on	off	on	off	on	on	off
174;175	on	off	on	off	on	on	on
176;177	on	off	on	on	off	off	off
178;179	on	off	on	on	off	off	on
180;181	on	off	on	on	off	on	off
182;183	on	off	on	on	off	on	on
184;185	on	off	on	on	on	off	off
186;187	on	off	on	on	on	off	on
188;189	on	off	on	on	on	on	off
190;191	on	off	on	on	on	on	on
192;193	on	on	off	off	off	off	off
194;195	on	on	off	off	off	off	on
196;197	on	on	off	off	off	on	off
198;199	on	on	off	off	off	on	on
200;201	on	on	off	off	on	off	off
202;203	on	on	off	off	on	off	on
204;205	on	on	off	off	on	on	off
206;207	on	on	off	off	on	on	on
208;209	on	on	off	on	off	off	off

Table B-1 Unit Select Number Switch Settings (Cont)

Unit Number	DIP Switch Position Number						
	7	6	5	4	3	2	1
210/211	on	on	off	on	off	off	on
212/213	on	on	off	on	off	on	off
214/215	on	on	off	on	off	on	on
216/217	on	on	off	on	on	off	off
218/219	on	on	off	on	on	off	on
220/221	on	on	off	on	on	on	off
222/223	on	on	off	on	on	on	on
224/225	on	on	on	off	off	off	off
226/227	on	on	on	off	off	off	on
228/229	on	on	on	off	off	on	off
230/231	on	on	on	off	off	on	on
232/233	on	on	on	off	on	off	off
234/235	on	on	on	off	on	off	on
236/237	on	on	on	off	on	on	off
238/239	on	on	on	off	on	on	on
240/241	on	on	on	on	off	off	off
242/243	on	on	on	on	off	off	on
244/245	on	on	on	on	off	on	off
246/247	on	on	on	on	off	on	on
248/249	on	on	on	on	on	off	off
250/251	on	on	on	on	on	off	on
252/253	on	on	on	on	on	on	off
ILLEGAL	on	on	on	on	on	on	on

GLOSSARY

Adapter module – interfaces the RC25 disk drive to the host computer system. It adapts the computer system bus to the disk interface bus.

Bus – is a path that information (data, program, control messages) takes between one part of a computer system and another.

Cartridge – is made up of a removable disk platter in an airtight, plastic, formed enclosure. The disk platter and the enclosure make up the cartridge.

Cartridge receiver – is the area in the disk drive into which the removable disk cartridge fits.

Diagnostic – is a procedure for detecting and isolating a malfunction or mistake.

Disk cartridge – See Cartridge.

Disk drive – is the device in which the disk platters rotate. It consists of the fixed disk platter, the removable disk cartridge, drive mechanics, all control electronics, power supply, and the enclosure.

Disk subsystem – is made up of the disk drive, the adapter module, and the associated cables.

Host system – is the immediate computer system to which the RC25 disk drive and adapter connect.

Indicator – provides a visible means of communicating status to the operator.

Platter – is a rigid disk medium on which data is recorded.

Receiver – See **Cartridge receiver**.

Receiver door – is the hinged door that opens to allow insertion and removal of the disk cartridge. It closes to ensure an airtight operating environment.

Spindle – is the hub and drive shaft on which the disk platters rotate.

Spindle motor – is the mechanism that provides rotational drive to the spindle.

RC25 DISK SUBSYSTEM USER GUIDE

Your comments and suggestions will help us in our continuous effort to improve the quality and usefulness of our publications.

What is your general reaction to this manual?

	Excellent	Very Good	Good	Fair	Poor
Accuracy	<input type="checkbox"/>	<input type="checkbox"/>	<input type="checkbox"/>	<input type="checkbox"/>	<input type="checkbox"/>
Completeness	<input type="checkbox"/>	<input type="checkbox"/>	<input type="checkbox"/>	<input type="checkbox"/>	<input type="checkbox"/>
Organization	<input type="checkbox"/>	<input type="checkbox"/>	<input type="checkbox"/>	<input type="checkbox"/>	<input type="checkbox"/>
Format	<input type="checkbox"/>	<input type="checkbox"/>	<input type="checkbox"/>	<input type="checkbox"/>	<input type="checkbox"/>

What features are most useful?

(Notes, Tables, Illustrations, etc.) _____

Does the publication satisfy your needs?

Yes

No

What errors have you found?

(Ref. page no., table no., figure no.) _____

Additional Comments _____

Name _____

Street _____

Title _____

City _____

Company _____

State/Country _____

Department _____

Zip _____

The Documentation Products Directory and the DECdirect Guide contain information on the remainder of DIGITAL's technical documentation.

Copies of the above Directory and Guide, as well as additional copies of this document, are available by writing or calling:

Digital Equipment Corporation
Accessories and Supplies Group
P.O. Box CS2008
Nashua, New Hampshire 03061

Attention: Documentation Products
Telephone: 1-800-258-1710

Order No. EK-4RC25-UG-002

MY

DO NOT TEAR - FOLD HERE AND TAPE

digital



No Postage
Necessary
if Mailed in the
United States

BUSINESS REPLY MAIL

FIRST CLASS

PERMIT NO. 33

MAYLAND, VA

POSTAGE WILL BE PAID BY ADDRESSEE

DIGITAL EQUIPMENT CORPORATION
EDUCATIONAL SERVICES/QUALITY ASSURANCE
12 CROSBY DRIVE, BU/E08
BEDFORD, MA 01730



EDUCATIONAL SERVICES - TRAINING PROGRAMS

Digital Equipment Corporation's Educational Services Group provides one of the most extensive educational programs offered by a computer manufacturer.

Educational Services designs, develops, and delivers courses which help people learn skills and achieve understanding and expertise in using computers. Our courses range from introductory to advanced, covering basic computer knowledge through the highest level technical subjects. We design many courses for users of Digital's hardware and software, and also create courses which are not product specific.

More than 500 courses, taught in 17 languages are available. Educational Services constantly creates new courses which reflect the latest technologies, such as interactive video. Currently, the following training is:

- Self-Paced Instruction (SPI)
- Computer-Based Instruction (CBI)
- Lecture/Lab Courses
- Customized Courses
- Seminars
- Digital Press

Every quarter Educational Services publishes *The Digest*, a planning tool for developing individual training programs. *The Digest* includes a complete list of available courses and their locations.

Please call your nearest Sales Representative or Digital Education Center for more information about the courses and services you need; or contact:

- United States: Customer Training Manager
Digital Equipment Corporation
Educational Services
12 Crosby Drive
Bedford, Massachusetts 01730
Telephone: (617) 276-1373
- Europe: Customer Training Manager
European Area Headquarters
Digital Equipment Corporation International
12 Avenue des Morgines
Case Postale 510
CH-1213 Petit-Lancy 1
Geneva, Switzerland
Telephone: (41)-(22)-933311
- Other Areas: Customer Training Manager
General International Area Office
Digital Equipment Corporation
100 Nagog Park
Acton, Massachusetts 01720
Telephone: (617) 264-6783

Digital Equipment Corporation • Maynard, MA 01754