

MICRO/ PDP-11 SYSTEM

TECHNICAL
MANUAL

digital

MICRO/ PDP-11 SYSTEM

TECHNICAL MANUAL

Prepared by Educational Services
of
Digital Equipment Corporation

1st Edition, May 1983
2nd Edition, January 1984

© Digital Equipment Corporation 1984

All Rights Reserved.

Printed in U.S.A.

The information in this document is subject to change without notice. Digital Equipment Corporation assumes no responsibility for any errors that may appear in this manual.

Digital Equipment Corporation assumes no responsibility for the use or reliability of its software on equipment that is not supplied by Digital.

FCC Notice: The MICRO/PDP-11 system generates, uses, and may emit radio frequency energy. The equipment has been type tested and found to comply with the limits for a Class A computing device pursuant to Subpart J of Part 15 of FCC Rules, which are designed to provide reasonable protection against such radio frequency interference when operated in a commercial environment. Operation of this equipment in a residential area may cause interference in which case the user at his own expense may be required to take measures to correct the interference.

The manuscript for this book was created using a DIGITAL Word Processing System and, via a translation program, was automatically typeset on DIGITAL's DECset Integrated Publishing System. Book production was done by Educational Services Development and Publishing in Marlboro and Bedford, MA.

UNIX is a trademark of Bell Laboratories.

The following are trademarks of Digital Equipment Corporation.

digital	Letterprinter 100	Rainbow
CTS-300	Letterwriter 100	RSTS
DEC	LSI-11	RSX
DECmate	MASSBUS	TOPS-10
DECsystem-10	MICRO/PDP-11	TOPS-20
DECSYSTEM-20	MicroPower/Pascal	UNIBUS
DECUS	PDP	VAX
DECwriter	P/OS	VMS
DIBOL	Professional	VT
LA	QBus	Work Processor

CONTENTS

	Page
PREFACE	
CHAPTER 1 INTRODUCTION AND SYSTEM DESCRIPTION	
1.1 INTRODUCTION.....	1-1
1.2 SYSTEM DESCRIPTION.....	1-1
1.3 BASIC SYSTEM OPERATION.....	1-3
1.3.1 Using the Control Panel.....	1-3
1.3.2 Handling and Storing Diskettes.....	1-6
1.3.3 Loading and Unloading Diskettes.....	1-8
1.3.4 Write Protection of Diskettes.....	1-14
1.3.5 Bootstrap Commands and Dialog.....	1-14
1.3.6 Using XXDP+ Diagnostic Software to Copy and Create Backup Diskettes.....	1-15
CHAPTER 2 SYSTEM COMPONENTS	
2.1 INTRODUCTION.....	2-1
2.2 KDF11-BP CENTRAL PROCESSING UNIT (CPU) ASSEMBLY.....	2-1
2.3 MSV11-PK MEMORY MODULE.....	2-8
2.4 DZV11-CP ASYNCHRONOUS MULTIPLEXER.....	2-11
2.5 RD51/RX50 CONTROLLER AND DRIVE SUBSYSTEM.....	2-14
2.5.1 RQDX1 Controller Module.....	2-14
2.5.2 RD51 Fixed Disk Drive.....	2-16
2.5.3 RX50 Diskette Drive.....	2-17
2.6 BA23-A MOUNTING BOX.....	2-18
2.6.1 Backplane Assembly.....	2-18
2.6.2 H7864 Power Supply.....	2-21
2.6.3 Control Panel (54-15610).....	2-22
2.6.4 Patch and Filter Panel Assembly.....	2-23
CHAPTER 3 PROGRAMMING	
3.1 INTRODUCTION.....	3-1
3.2 HARDWARE-INITIATED DIAGNOSTICS.....	3-1
3.3 DIAGNOSTIC SOFTWARE.....	3-3
3.3.1 User Test Diskette.....	3-4
3.3.2 Field Service Test Diskettes.....	3-5
3.4 OPERATING SYSTEM SOFTWARE.....	3-5
3.4.1 Micro/RXS, RSX-11M, and RSX-11M-PLUS.....	3-5
3.4.2 Micro/RSTS.....	3-5
3.4.3 RT-11.....	3-5
3.4.3.1 CTS-300.....	3-6
3.4.3.2 MicroPower/Pascal.....	3-6
3.4.4 V7M-11.....	3-6
3.4.5 DSM-11.....	3-6

CONTENTS (Cont)

	Page
CHAPTER 4	TERMINAL OPTIONS
4.1	INTRODUCTION 4-1
4.2	VT100 SERIES VIDEO TERMINALS 4-1
4.3	LA120-DA/DECwriter III 4-2
4.4	LA100 LETTERWRITER 100 4-4
CHAPTER 5	SYSTEM REQUIREMENTS AND MAINTENANCE
5.1	INTRODUCTION 5-1
5.2	ENVIRONMENT 5-1
5.3	SYSTEM TESTS AND ERROR DETECTION 5-2
5.3.1	Bootstrap/Diagnostic ROM Programs 5-2
5.3.2	User Test Diskette 5-7
5.4	ON-LINE DEBUGGING TECHNIQUE (ODT) 5-8
5.5	TROUBLESHOOTING WITH THE DEC/X11 RUN-TIME EXERCISER 5-9
5.5.1	Error Messages 5-10
5.5.1.1	System Error Message 5-10
5.5.1.2	Data Error Message 5-10
5.5.1.3	Status Error Message 5-11
5.5.2	Selecting and Deselecting Program Modules 5-11
5.5.3	Expanding the Run-Time Exerciser 5-12
5.6	TROUBLESHOOTING WITH THE XXDP+ DIAGNOSTIC PROGRAMS 5-12
5.6.1	Error Messages 5-12
5.6.2	Restarting Programs 5-12
5.6.3	Modifying a Diagnostic Program 5-13
5.7	TROUBLESHOOTING PROCEDURES 5-13
5.8	CORRECTIVE MAINTENANCE 5-16
5.8.1	KDF11-BP Central Processing Unit Assembly Removal and Replacement Procedure 5-18
5.8.2	MSV11-PK (M8067) Memory Module Removal and Replacement Procedure 5-19
5.8.3	DZV11-CP Asynchronous Multiplexer Removal and Replacement Procedure 5-20
5.8.4	RQDX1 (M8639) Module Removal and Replacement Procedure 5-21
5.8.5	RD51-A Fixed Disk Drive Removal and Replacement Procedure 5-21
5.8.5.1	RD51-A Fixed Disk Drive Read/Write Printed Circuit Board Removal and Replacement Procedure 5-25
5.8.5.2	RD51-A Fixed Disk Drive Formatting Procedure 5-28
5.8.6	RX50-AA Diskette Drive Removal and Replacement Procedure 5-29
5.8.7	H7864 Power Supply Removal and Replacement Procedure 5-32
5.8.7.1	System Unit Front Fan Removal and Replacement Procedure 5-34

CONTENTS (Cont)

	Page
5.8.7.2	System Unit Rear Fan Removal and Replacement Procedure 5-35
5.8.8	Backplane Assembly Removal and Replacement Procedure..... 5-36
5.8.9	Control Panel (54-15610) Removal and Replacement Procedure..... 5-37
CHAPTER 6	SYSTEM OPTIONS AND RULES FOR EXPANSION
6.1	INTRODUCTION 6-1
6.2	CENTRAL PROCESSING UNIT OPTIONS 6-1
6.2.1	KEF11-AA Floating-Point Option..... 6-1
6.2.2	FPF11 Floating-Point Option Module 6-1
6.2.3	KEF11-BB Commercial Instruction Set Option 6-1
6.3	MEMORY EXPANSION..... 6-2
6.4	COMMUNICATIONS HARDWARE OPTIONS 6-5
6.5	MASS STORAGE OPTIONS..... 6-5
APPENDIX A	BACKPLANE PIN ASSIGNMENTS
APPENDIX B	ON-LINE DEBUGGING TECHNIQUE (ODT) COMMANDS
APPENDIX C	GLOSSARY

FIGURES

Figure No.	Title	Page
1-1	MICRO/PDP-11 System Packages 1-2	
1-2	MICRO/PDP-11 System Control Panel..... 1-3	
1-3	RX50 Diskette Drive Active Drive Light Locations 1-7	
1-4	Opening Drive Door 1 of the RX50 Diskette Drive 1-8	
1-5	Opening Drive Door 2 of the RX50 Diskette Drive 1-9	
1-6	Inserting a Diskette into Drive 1..... 1-10	
1-7	Inserting a Diskette into Drive 2..... 1-11	
1-8	Closing Drive Door 1..... 1-12	
1-9	Closing Drive Door 2..... 1-13	
1-10	Write-Protect Tab Application..... 1-14	
2-1	KDF11-BE Module Jumper, Switch, and Diagnostic LED Locations 2-2	
2-2	CPU Patch and Filter Panel 2-7	
2-3	MSV11-PK Memory Module Factory Jumper Configuration 2-9	
2-4	DZV11-A Module Jumper and Switch Locations 2-11	
2-5	DZV11 Patch and Filter Panel 2-13	
2-6	RQDX1 Controller Module Jumper and LED Locations 2-14	
2-7	RD51 Fixed Disk Drive..... 2-16	
2-8	RX50 Diskette Drive..... 2-17	
2-9	BA23-A Mounting Box 2-18	
2-10	Backplane..... 2-19	

FIGURES (Cont)

Figure No.	Title	Page
2-11	Backplane Grant Continuity Chaining	2-19
2-12	Signal Distribution Printed Circuit Board Layout	2-20
2-13	H7864 Power Supply.....	2-21
2-14	Control Panel Assembly	2-22
2-15	Patch and Filter Panel Assembly	2-23
4-1	VT100 Terminal.....	4-1
4-2	VT100 Series of Terminals, Comparison Chart	4-2
4-3	LA120-DA DECwriter III.....	4-3
4-4	Hardcopy Terminals, Comparison Chart	4-3
4-5	LA100 Letterwriter 100.....	4-4
5-1	Diagnostic LED Locations.....	5-5
5-2	Troubleshooting Flowchart	5-14
5-3	MICRO/PDP-11 System FRUs, Expanded View.....	5-16
5-4	Front Top Cover Access.....	5-22
5-5	RD51-A Fixed Disk Drive Release Tab	5-22
5-6	RD51-A Fixed Disk Drive Signal Cabling Removal	5-23
5-7	RD51-A Fixed Disk Drive Power Cable Removal	5-23
5-8	RD51-A Fixed Disk Drive Removal.....	5-24
5-9	RD51-A Fixed Disk Drive Skid Plate Removal.....	5-25
5-10	RD51-A Fixed Disk Drive Read/Write Printed Circuit Board Screw Removal.....	5-26
5-11	RD51-A Fixed Disk Drive Connector P5 Removal	5-26
5-12	RD51-A Fixed Disk Drive Connectors P8, P7, and P6 Removal.....	5-27
5-13	RD51-A Fixed Disk Drive Connector P4 Removal	5-27
5-14	RD51-A Fixed Disk Drive Read/Write Printed Circuit Board Removal.....	5-28
5-15	Front Top Cover Access.....	5-30
5-16	RX50-AA Diskette Drive Signal and Power Cable Removal.....	5-30
5-17	RX50-AA Diskette Drive Release Tab.....	5-31
5-18	RX50-AA Diskette Drive Removal.....	5-31
5-19	H7864 Power Supply (Rear View).....	5-32
5-20	H7864 Power Supply (Front View).....	5-33
5-21	H7864 Power Supply (Side View)	5-33
5-22	Fan Power Cable Connection	5-35
6-1	Communications Hardware Options.....	6-5
A-1	Quad Module Contact Finger Identification.....	A-1

TABLES

Table No.	Title	Page
1-1	MICRO/PDP-11 System Model Comparison Chart.....	1-1
1-2	MICRO/PDP-11 System Control Panel Switches.....	1-4
1-3	MICRO/PDP-11 System Control Panel Indicator LEDs	1-5
2-1	KDF11-BE Module Factory Jumper Configuration	2-3
2-2	KDF11-BE Module Bootstrap/Diagnostic Switch Configuration - Switch S1(E102).....	2-4
2-3	KDF11-BE Module SLU Baud Rate Factory Switch Configuration - Switch S2(E114).....	2-6

TABLES (Cont)

Table No.	Title	Page
2-4	CPU Patch and Filter Panel Rotary Switch Settings.....	2-7
2-5	MSV11-PK Memory Module Factory Jumper Configuration	2-10
2-6	DZV11-A Module Factory Jumper Configuration	2-12
2-7	DZV11-A Module Factory Switch Settings.....	2-12
2-8	RQDX1 Controller Module Factory Jumper Configuration	2-15
5-1	MICRO/PDP-11 System Environmental Specifications	5-1
5-2	MICRO/PDP-11 System Power Requirements.....	5-2
5-3	Boot/Diagnostic ROM Error Types.....	5-3
5-4	Diagnostic LED Error Displays.....	5-6
5-5	XXDP+ Diagnostic Programs.....	5-11
5-6	Recommended Repair Procedures for MICRO/PDP-11 System FRUs	5-17
5-7	Read/Write Printed Circuit Board Jumper Configuration.....	5-25
6-1	MSV11-P Memory Module Versions	6-2
6-2	M8067-KA Memory Module CSR Address Selection	6-2
6-3	M8067-KA Memory Module Starting Address Configurations (FAR).....	6-3
6-4	M8067-KA Starting Address Configurations (PSA).....	6-3
6-5	Additional MICRO/PDP-11 System Memory Options.....	6-4
6-6	Mass Storage Options.....	6-5
A-1	KDF11-BE (M8189) Module Backplane Pin Assignments (Rows A and B).....	A-2
A-2	KDF11-BE (M8189) Module Backplane Pin Assignments (Rows C and D).....	A-2
A-3	MSV11-PK (M8067) Module Backplane Pin Assignments (Rows A and B).....	A-3
A-4	MSV11-PK (M8067) Module Backplane Pin Assignments (Rows C and D).....	A-4
A-5	DZV11-A (M7957) Module Backplane Pin Assignments (Rows A and B).....	A-4
A-6	DZV11-A (M7957) Module Backplane Pin Assignments (Rows C and D).....	A-5
A-7	RQDX1 (M8639) Module Backplane Pin Assignments (Rows A and B).....	A-5
A-8	RQDX1 (M8639) Module Backplane Pin Assignments (Rows C and D).....	A-6
B-1	Console ODT Commands.....	B-2

PREFACE

This technical manual provides you with information on the operation, configuration, and maintenance of the MICRO/PDP-11 system.

Chapter 1 provides procedures for the operation of the MICRO/PDP-11 system. These procedures explain how to use the control panel and diskettes.

Chapter 2 includes functional descriptions of the field-replaceable units (FRUs) that make up the MICRO/PDP-11 system. The descriptions include the factory switch and jumper configurations of the units.

Chapter 3 contains basic programming information. Included are the hardware-initiated diagnostics [from the boot/diagnostic ROM (read-only memory)], the software-initiated diagnostics (from the user test and Field Service test diskettes), and a summary of the types of operating systems that can be used to run the MICRO/PDP-11 system.

Chapter 4 describes the optional terminals recommended for use with the MICRO/PDP-11 system.

Chapter 5 describes the environmental requirements needed for the MICRO/PDP-11 system to operate properly, as well as directions for testing and isolating failures in the system. Removal and replacement procedures for each of the FRUs are also included.

Chapter 6 explains the options that may be added to the MICRO/PDP-11 system and how the system may be expanded.

Appendix A provides the backplane pin assignments for the modules installed in the MICRO/PDP-11 system.

Appendix B lists the on-line debugging technique (ODT) commands and their functions.

Appendix C is a glossary of terms that apply to the MICRO/PDP-11 system.

Related Documentation

The documents listed below provide additional information and may be of interest to MICRO/PDP-11 system users.

Title	Document Number
Microcomputer Interfaces Handbook	EB-20175-20
Microcomputers and Memories Handbook	EB-18451-20
PDP11 Software Handbook	EB-18687-20
MICRO/PDP-11 Handbook	EB-24944-18
KDF11-BA CPU Module User's Guide	EK-KDFEB-UG
KDF11-B Field Maintenance Print Set	MP-01236
MSV11-P User's Guide	EK-MSVOP-UG
DZV11 Asynchronous Multiplexer Technical Manual	EK-DZV11-TM
MICRO/PDP-11 System Site Preparation and Verification Guide	EK-OLCP5-SP
MICRO/PDP-11 System Unpacking and Installation Guide	EK-OLCP5-IN
MICRO/PDP-11 System Owner's Manual	EK-OLCP5-OM
MICRO/PDP-11 System Pocket Service Guide	EK-OLCP5-PS
MICRO/PDP-11 System Assembly Drawings	70-20442
BA23-A Unit Assembly Drawings	BA23-A-DBP
11C23 Unit Assembly Drawings	11C23-D-DBP
11A23 Unit Assembly Drawings	11A23-D-DBP
MICRO/PDP-11 System Illustrated Parts Breakdown	EK-OLCP5-IP
MICRO/PDP-11 System Options Manual	EK-OLCP5-OD
RQDX1 Controller Module User's Guide	EK-RQDX1-UG
XXDP+/SUPR User's Manual	AC-F348A-MC
DEC/X11 User's Manual	AC-F053-MC
DEC/X11 Cross-Reference Manual	AC-F055C-MC

You can order these documents from:

Digital Equipment Corporation
Accessories and Supplies Group
P.O. Box CS2008
Nashua, New Hampshire 03061

Attention: Documentation Products

CHAPTER 1

INTRODUCTION AND SYSTEM DESCRIPTION

1.1 INTRODUCTION

The MICRO/PDP-11™ system is a general-purpose microcomputer system with integral mass storage. The system is PDP-11 processor-based with 22-bit addressing capability. It runs a variety of software such as the Micro/RXS, RSX-11M, RSX-11M-PLUS, RT-11, CTS-300, DSM, V7M-11, and Micro/RSTS operating systems.

The MICRO/PDP-11 system is available in three packages: the rack mount package, the tabletop package, and the floor mount package. The floor mount package is converted to the tabletop package by removing the floor mount pedestal and installing four rubber feet. The three packages are shown in Figure 1-1.

1.2 SYSTEM DESCRIPTION

Several different models of the MICRO/PDP-11 system are available. Table 1-1 lists the various MICRO/PDP-11 models and indicates the modules and components included with each. Refer to Chapter 2 for additional information about each of these system components.

Table 1-1 MICRO/PDP-11 System Model Comparison Chart

Model Numbers	Components included:					
	KDF11-BP	MSV11-PK	DZV11-CP	RQDX1	RD51-A	RX50-AA
11C23-F	*	*		*	*	*
11C23-R	*	*		*	*	*
SX-RA500-EX	*	*	*	*	*	*
11C23-FA	*	*		*	*	*
11C23-RA	*	*		*	*	*
SX-RA500-FA	*	*	*	*	*	*
11A23-F	*	*		*		*
11A23-R	*	*		*		*

* Included.

The -F (or -FA or -EX) suffix indicates a floor mount (or tabletop) package.

The -R (or -RA) suffix indicates a rack mount package.

The -FA or -RA suffix includes the Installation Accessories Box. The Installation Accessories Box includes: documentation, diagnostic diskettes, a power cord, a terminal cable (BC22D-10), control panel labels, two screwdrivers, and a grant card (G7272).

The SX- suffix includes the QJB51-DZ General Software License.

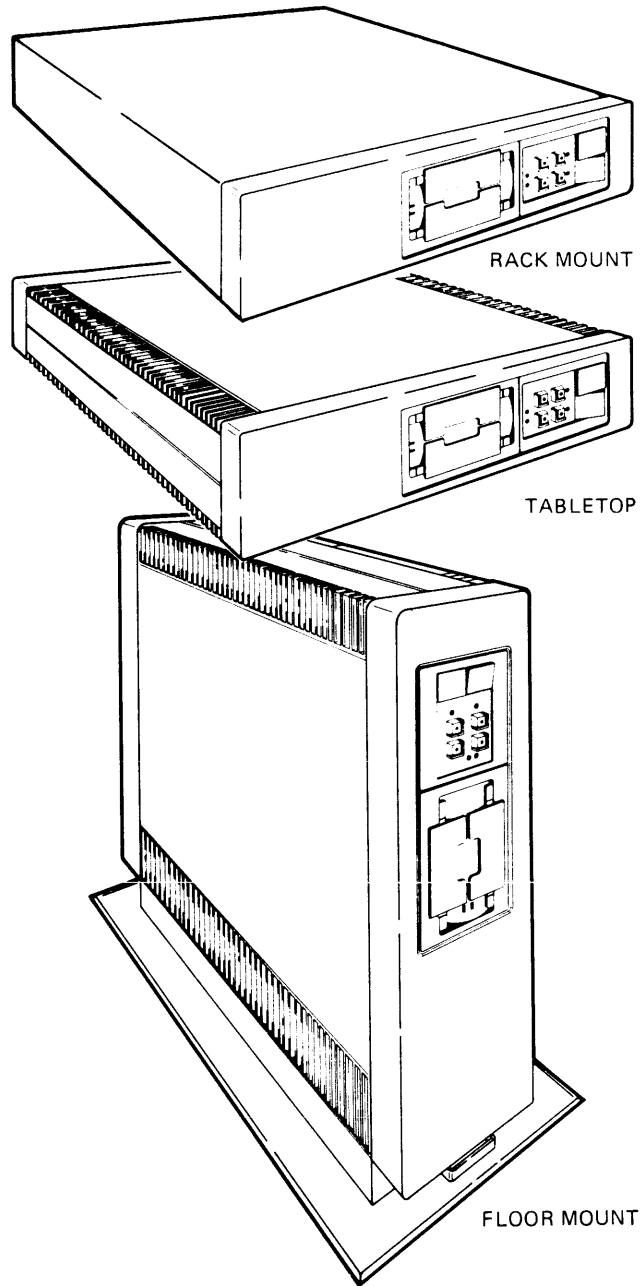

MR-9318

Figure 1-1 MICRO/PDP-11 System Packages

1.3 BASIC SYSTEM OPERATION

To operate the MICRO/PDP-11 system, you use the control panel to apply power to the system. You use the RX50K diskette to begin running the diagnostic software or system operation software. A description of each of these procedures follows.

1.3.1 Using the Control Panel

The control switches and status indicators for the components of the system are on the MICRO/PDP-11 system control panel. The switches and indicators are shown in Figure 1-2. The switches and their functions are listed in Table 1-2. Some switches have a light-emitting diode (LED) mounted in their center to indicate their status. The indicator LEDs and their meanings are listed in Table 1-3.

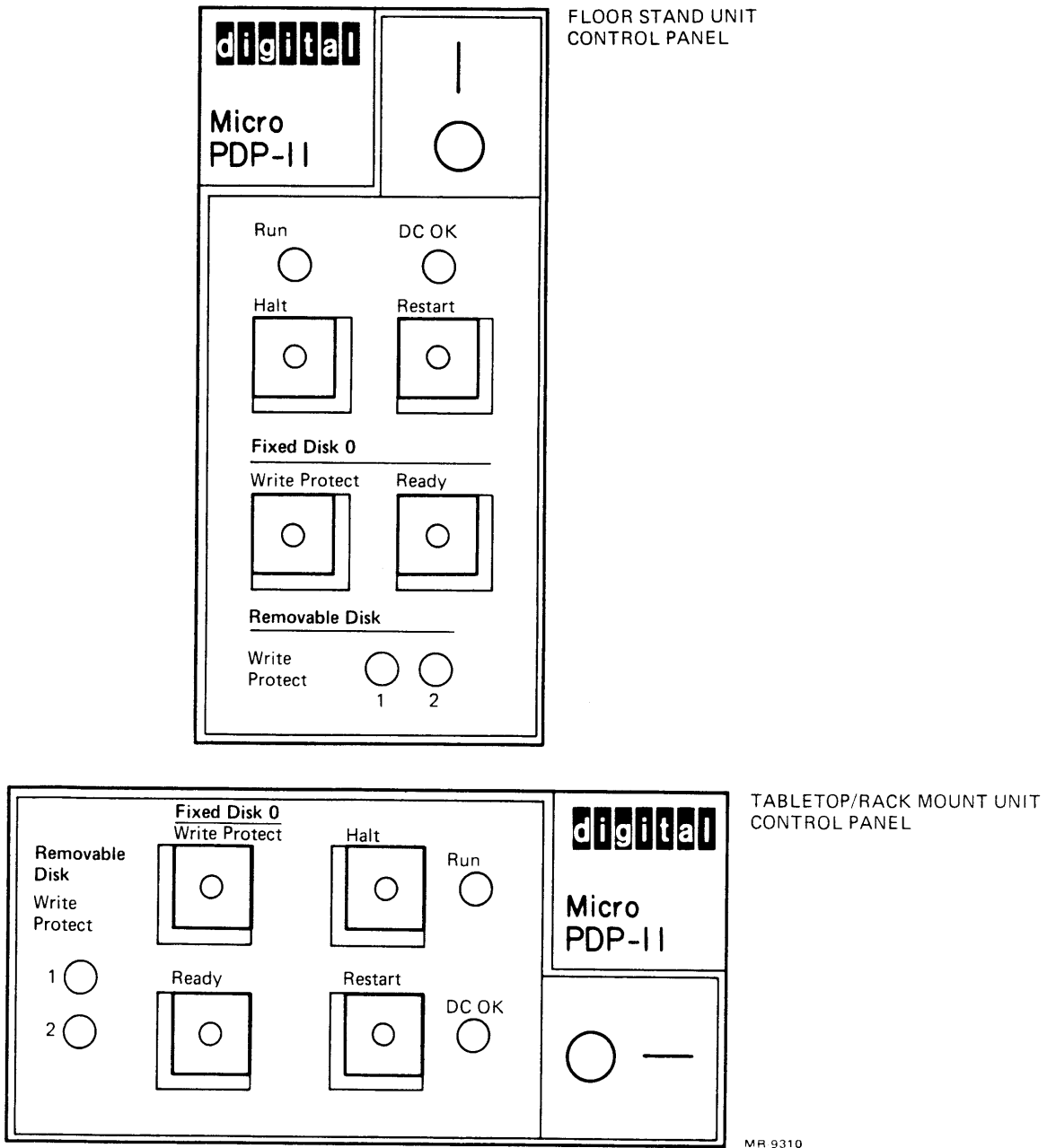

Figure 1-2 MICRO/PDP-11 System Control Panel

Table 1-2 MICRO/PDP-11 System Control Panel Switches

Switch	Position	Function
Power 1,0 (rocker switch)	1	Turns on the system power. This switch glows red when the system is on.
	0	Turns off the system power.
Halt	In (LED lit)	The CPU halts and responds to console on-line debugging technique (ODT) commands. The basic ODT commands and their functions are listed in Appendix B. Refer to the <i>Microcomputers and Memories Handbook</i> (EB-18451-20) for additional ODT information.
	Out (LED off)	Enables the processor to run.
Restart (momentary switch)	In	When the halt switch is out (LED off), the CPU restarts by carrying out a power-up sequence and displaying the bootstrap dialog as shown in Paragraph 1.3.5.
		When the halt switch is in (LED lit), the restart switch will single-step the current program, executing a single instruction each time the switch is pressed.
Fixed Disk 0 Protect Write	In (LED lit)	Write protects the RD51 fixed disk drive.
	Out (LED off)	Enables writing to the RD51 fixed disk drive.
Fixed Disk 0 Ready	Out (LED lit)	Places the RD51 fixed disk drive on-line.
	In (LED off)	Places the RD51 fixed disk drive off-line.

Table 1-3 MICRO/PDP-11 System Control Panel Indicator LEDs

Indicator LED	Function
Run	This LED is lit when the CPU is operating; the LED goes off when the CPU is not executing instructions.
DC OK	This LED is lit when the power supply is generating correct dc power output voltages.
Removable Disk Write Protect*	
1	When this LED is lit, the diskette in RX50 diskette drive 1 is write-protected.
2	When this LED is lit, the diskette in RX50 diskette drive 2 is write-protected.

* Removable disk write protect is selected by placing an adhesive label over the write-protect slot of the diskette. Refer to Paragraph 1.3.4 for complete instructions.

1.3.2 Handling and Storing Diskettes

Improper handling or storage of diskettes will destroy recorded data and may damage the read/write heads in the RX50 diskette drive. Here are some suggestions on handling diskettes.

- Return diskettes to their protective envelopes when they are not being used.
- Store diskettes vertically and loosely to avoid warping their jackets.
- Use a felt tip pen to mark the diskettes' jackets. (Using a pencil or ball-point pen creases the jacket and the diskette inside.)
- Insert diskettes into the drives carefully. Never force the drive doors closed.
- Never remove or insert a diskette while either of the two active drive lights on the RX50 diskette drive is lit.

CAUTION

Opening a drive door while either drive is busy (that is, while either of the active drive lights is lit) will damage data stored on the diskette(s). The locations of the active drive lights are shown in Figure 1-3.

- Never touch the recording surface where the diskette jacket is cut away for the read/write heads. Fingerprints will damage recorded data and the read/write heads.
- Never store diskettes in direct sunlight or near heaters where temperatures go above 52° C (125° F). High temperatures cause the jackets to warp.
- Never bend or fold the diskette jacket.
- Never bring diskettes near strong magnetic fields [over 50 oersteds within 76 mm (3 in)] and do not let steel objects touch the diskettes. In both cases, the data on the diskettes could be erased or weakened.

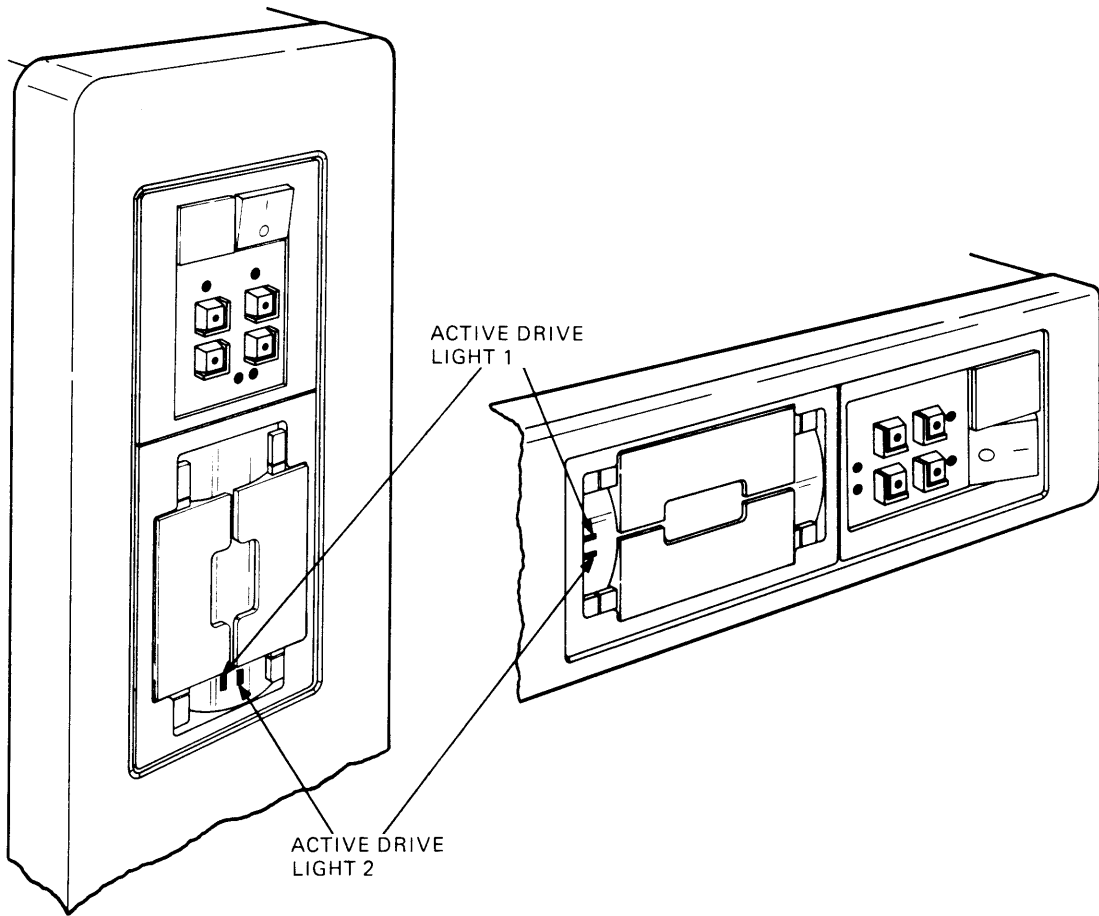

MR 9312

Figure 1-3 RX50 Diskette Drive Active Drive Light Locations

1.3.3 Loading and Unloading Diskettes

You load diskettes into the RX50 diskette drive in the following way.

1. Open the door of the desired drive. To open the door, press on the edge closest to the outside of the diskette drive. (See Figure 1-4 for drive 1, Figure 1-5 for drive 2.)

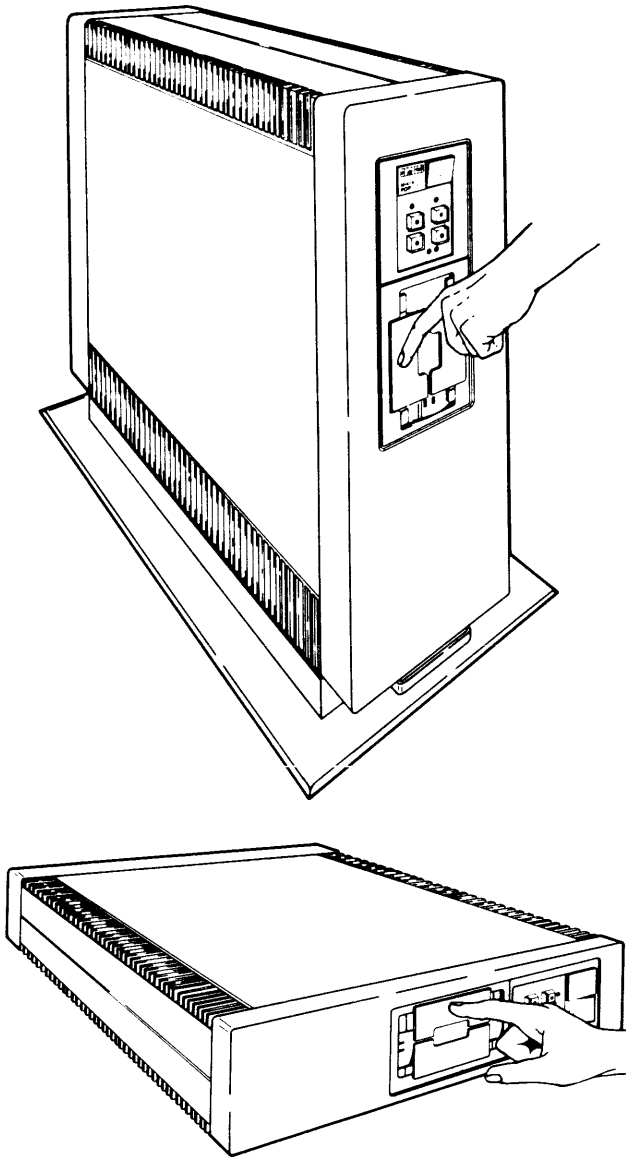

MR-9321

Figure 1-4 Opening Drive Door 1 of the RX50 Diskette Drive

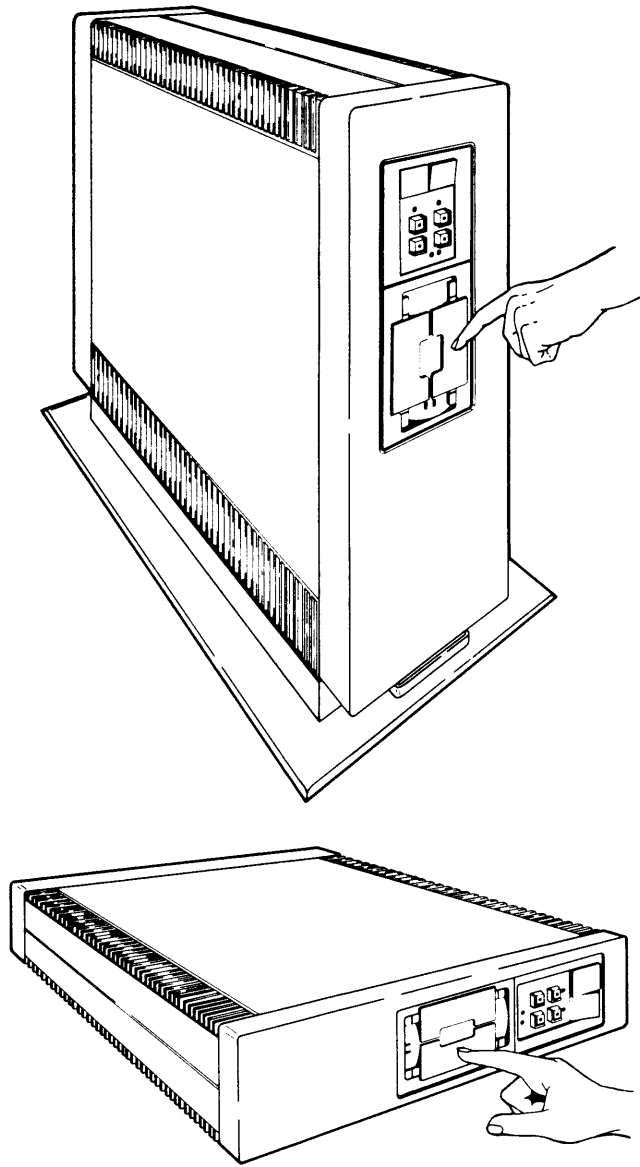

MR-9322

Figure 1-5 Opening Drive Door 2 of the RX50 Diskette Drive

2. Properly orient the diskette and insert it into the slot until it makes contact with the solid stop. The diskette should be oriented so that the read/write head access slot in the jacket is inserted into the drive first. The drive will record on the surface of the diskette closest to the center of the diskette drive. (See Figure 1-6 for drive 1, Figure 1-7 for drive 2.)

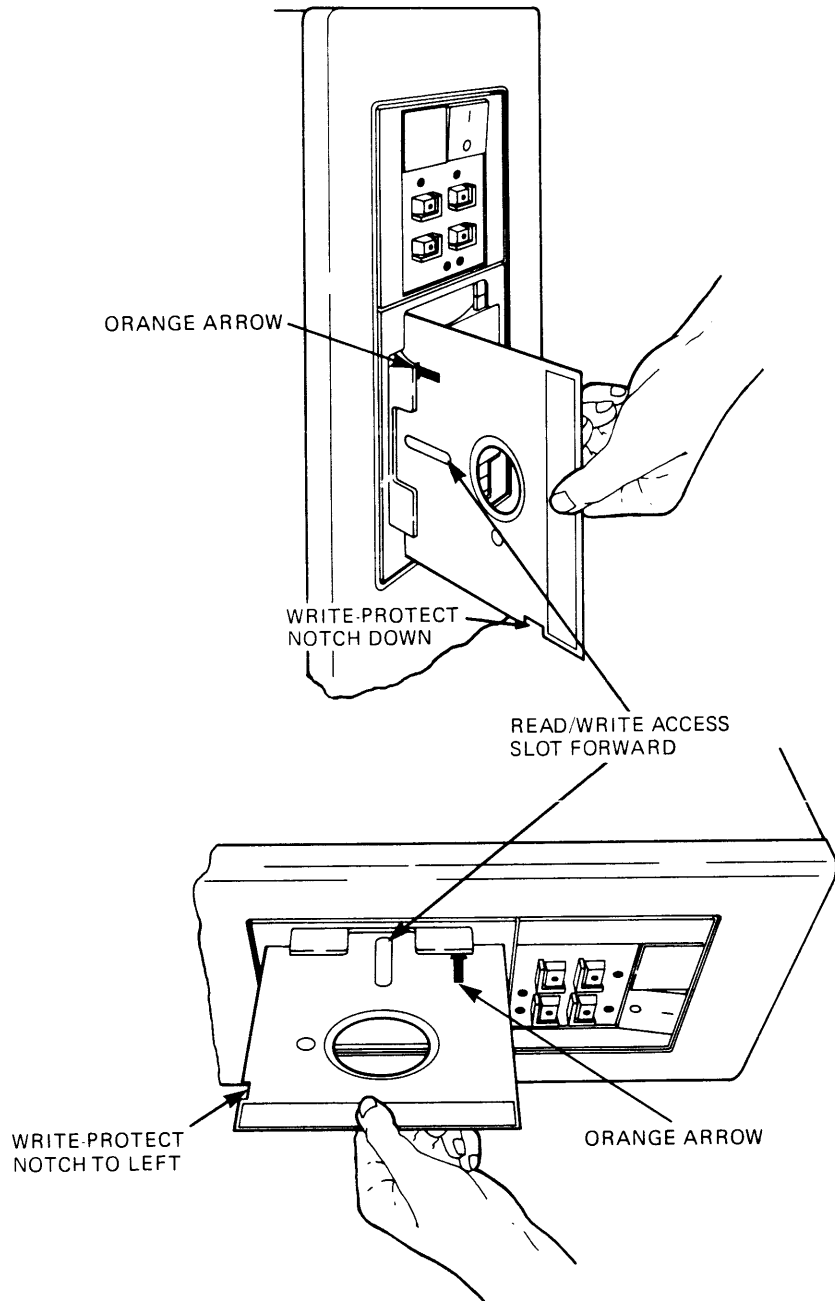

MR 9323

Figure 1-6 Inserting a Diskette into Drive 1

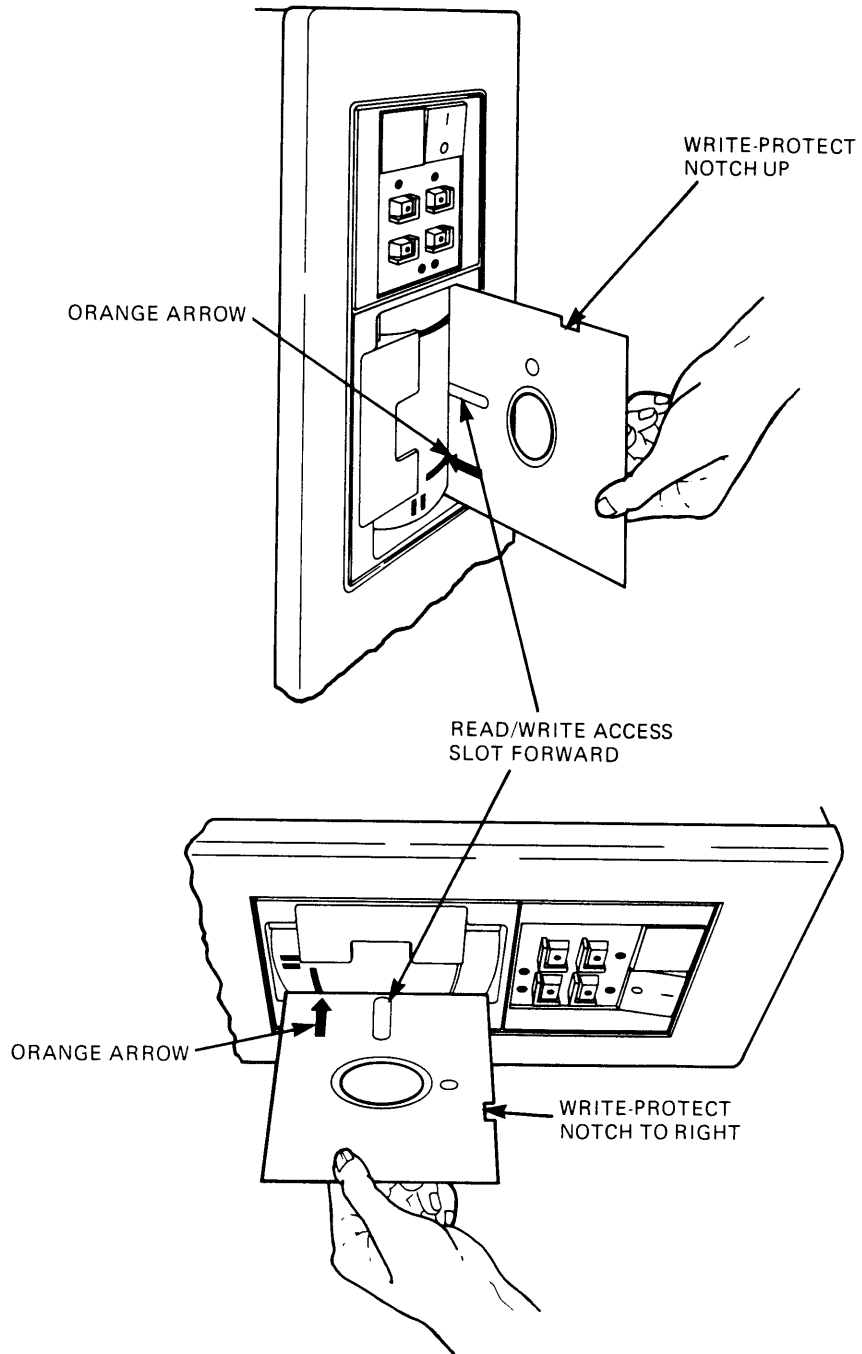

MR-9314

Figure 1-7 Inserting a Diskette into Drive 2

3. Close the door. Gently push the end of the door toward the center of the diskette drive. (See Figure 1-8 for drive 1, Figure 1-9 for drive 2.)

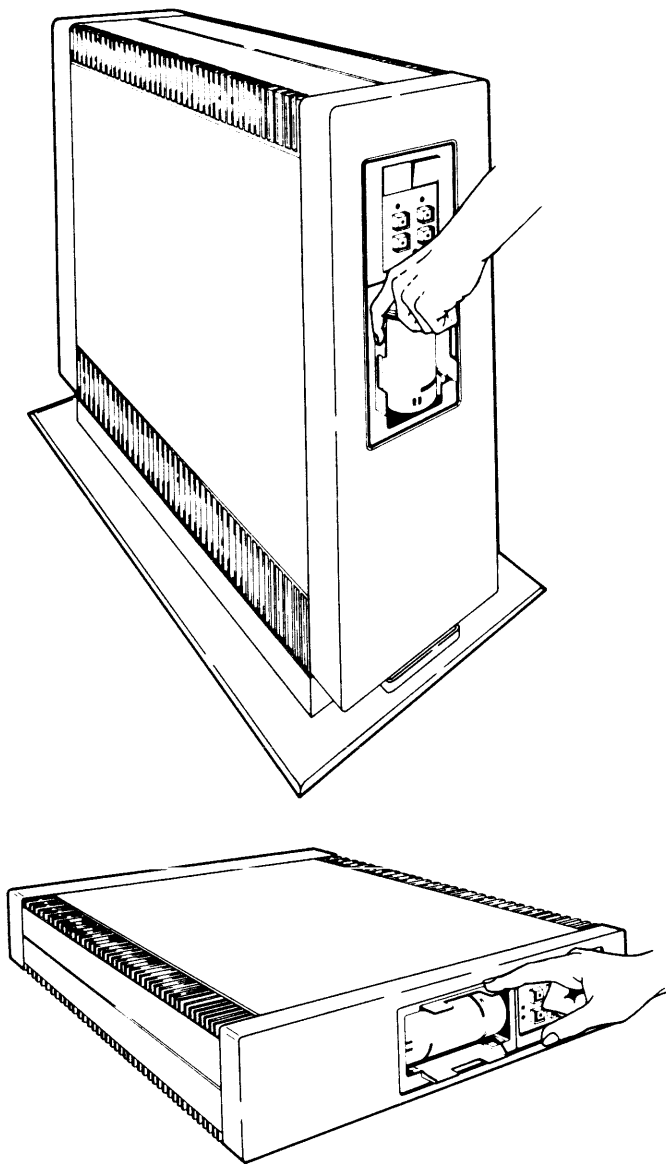

MR-9324

Figure 1-8 Closing Drive Door 1

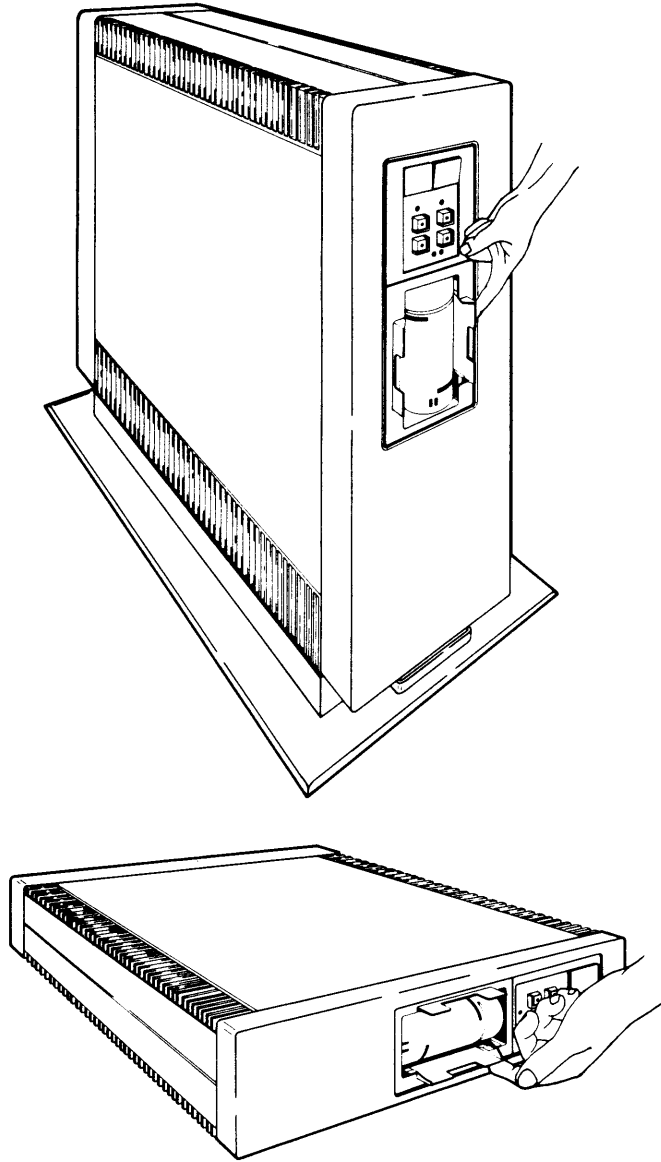

MR-9419

Figure 1-9 Closing Drive Door 2

The two active drive lights on the front of the diskette drive indicate which diskette the controller is currently accessing.

1.3.4 Write Protection of Diskettes

The RX50 diskette drive is equipped with a write-protect feature that protects the data on a diskette from accidental erasure. To write protect a diskette, cover the write-protect notch on its jacket with a write-protect tab. Some diskettes come with a package of adhesive-backed write-protect tabs. If these are not available, use ordinary adhesive-backed labels. Figure 1-10 shows how to apply a write-protect tab.

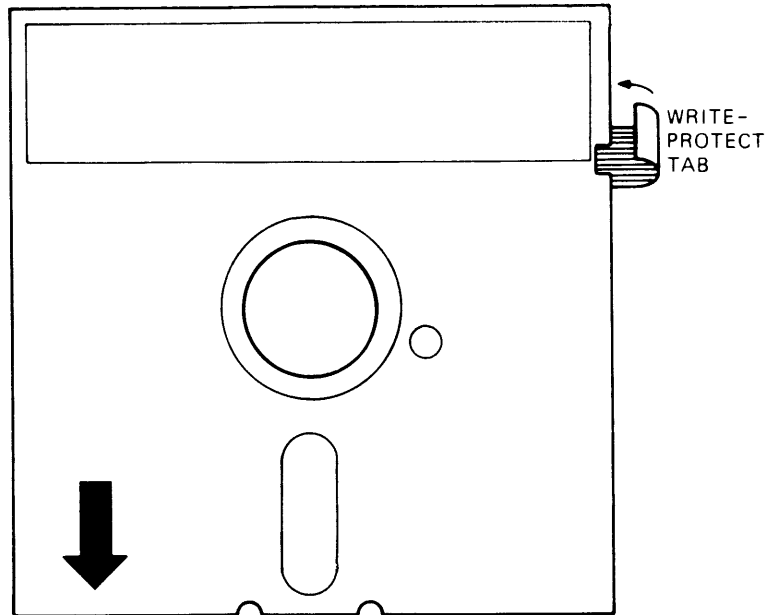

Figure 1-10 Write-Protect Tab Application

MR-10174

1.3.5 Bootstrap Commands and Dialog

When the MICRO/PDP-11 system is switched on (or restarted after being halted), the following message appears on the console terminal if switch S1 on the KDF11-BE module is in the appropriate configuration. (Table 2-2 lists the possible configurations of switch S1.)

```
KDF11B-BE ROM V0.8  
  
 128KW MEMORY  
 9 STEP MEMORY TEST  
  STEP 1 2 3 4 5 6 7 8 9  
TOTAL MEMORY ERRORS = 0  
CLOCK ENABLED
```

(This message is described in Paragraph 3.2. If the message does not appear, refer to Paragraph 5.3.1 to determine the cause.)

If the terminal used is not an American National Standards Institute (ANSI) terminal, the console displays 6n twice. (This is only an indication of the type of terminal being used.) If the terminal is an ANSI hardcopy-type terminal, it performs two line feed functions before it proceeds to the next message. If the terminal is an ANSI video terminal, it proceeds directly from the message listed above to the next message.

At this point, the system automatically attempts to find bootable mass storage control protocol (MSCP) media on the system. (To have other types of media automatically booted, switch S1 on the KDF11-BE module must be reconfigured. Table 2-2 lists the possible configurations of switch S1.) If neither the diskette drives nor the fixed disk is bootable at this time, a message similar to the following is displayed.

```
ERROR UNIT DU0  
ERR 16 NOT BOOTABLE
```

```
ERROR UNIT DU2  
ERR 16 NOT BOOTABLE
```

```
ERROR UNIT DU1  
ERR 16 NOT BOOTABLE  
WISH TO REBOOT [Y,(N)]?
```

You can, at this time, insert any bootable RX50K diskette. For example, suppose you insert the user test diskette. When you type **Y** and press the **Return** key, the system responds with the following message. (In this manual user input and key names are printed in **boldface**.)

```
BOOTING FROM DU1  
Loading . . . Please wait . . . . .
```

The unit specified in the message (in this case DU1) depends on which diskette drive you used. During the loading phase of the user test diskette, the console terminal displays a series of periods. This is followed by the appropriate prompt for the specific type of software present on the diskette.

1.3.6 Using XXDP+ Diagnostic Software to Copy and Create Backup Diskettes

You can copy the diagnostic software on one diskette onto a spare diskette by using the copy utility program, which is available on the Field Service test diskettes. This program transfers the complete contents of one diskette to another. To copy operating system diskettes, refer to the appropriate software manual for directions.

CAUTION

Be careful when using the copy command. If the source and destination codes are wrong and the source diskette is not write-protected, the system may copy a blank diskette onto a master diskette. This would destroy the original information on the master diskette.

Copy a diskette in the following way.

1. Find the Field Service test diskette that lists the UPD2 utility in its directory. Load this write-protected diskette into diskette drive 1.
2. Load a blank diskette into diskette drive 2. This diskette must not be write protected.
3. Initialize the system by pressing **RESTART** on the control panel.

4. After diskette drive 1 has been booted (see Paragraph 1.3.5), some XXDP+ dialog appears and the system monitor prompt . (period) is displayed. Type **R UPD2** and press the **Return** key as shown below. (In sample computer dialog, <CR> means to press the **Return** key.)

```
.R UPD2<CR>
UPD2.BIN
CHUP2B1 XXDP+ UPD2 UTILITY
RESTART:NNNNNN (a restart address is specified)
*
```

5. The * (asterisk) is the prompt for the UPD2 program monitor. Type the source and destination information for the copy program and press the **Return** key as follows.

```
COPY DQ2:=DQ1:<CR>
```

The data on the diskette in drive 1 (DQ1) will become the data on the diskette in drive 2 (DQ2). This destroys any data previously stored on the diskette in drive 2.

NOTE

In a system that has both an RD51 fixed disk drive and an RX50 diskette drive, the fixed disk drive is assigned as drive 0, and the diskette drives are assigned as drive 1 and drive 2. In a system with no RD51 fixed disk drive (refer to Table 1-1), the diskette drives are assigned as drive 0 and drive 1.

At this point the system responds with the following.

```
USER DATA ON DQ2 WILL BE DESTROYED
PROCEED? (Y/N CR=N)
FILE COPY OR IMAGE COPY? I=BLOCK F=FILE
*
```

6. At this time, make sure the master diskette is in drive 1 and the blank diskette is in drive 2. Also, verify that you gave the command in step 5 correctly. If you respond with an **F**, the system does the following.
- Zeros the output diskette (the blank diskette in drive 2).
 - Transfers the boot image and the monitor core image from the input diskette to the output diskette.
 - Performs a file-by-file transfer from the input diskette to the output diskette.

If you respond with an **I**, you are selecting an image copy. This selection requires that the devices involved be identical (for example, in copying from drive 1 to drive 2 of the RX50 diskette drive). In an image copy, each physical block of the input diskette is written to the corresponding physical block of the output diskette. When the operation is completed, the data on the output diskette is compared to the data on the input diskette in order to verify the accuracy of the transfer. This process takes more time than a file copy does.

7. In the example below, a file transfer is performed. Type **F** and press the **Return** key.

F<CR>

Though this process usually takes a few minutes, its duration varies with the number of files that must be transferred. When the process is done, a completion message is displayed, and the system returns to the UPD2 prompt * (asterisk).

8. Remove the master diskette from drive 1 and store it for future use. Remove the new copy from drive 2, and use it as your working copy. To copy another diskette at this time, insert a master diskette into drive 1 and a blank diskette into drive 2. Repeat the process starting at step 5.
9. To return to the system monitor . (period) prompt, type the following.

EXIT<CR>

10. The system displays the system monitor . (period) prompt on the console terminal. (Additional uses for the XXDP+ diagnostic software system of the Field Service test diskettes are described in Paragraphs 5.5 and 5.6.)

CHAPTER 2 SYSTEM COMPONENTS

2.1 INTRODUCTION

The MICRO/PDP-11 system is a general-purpose computer system that is available in several package designations. Each designation (refer to Table 1-1) indicates a specific combination of the following components: KDF11-BP central processing unit (CPU) assembly, MSV11-PK memory, DZV11-CP asynchronous multiplexer, RQDX1 disk drive controller, RD51 Winchester fixed disk drive, and RX50 diskette drive. These components are installed in a BA23-A mounting box.

Each of the components of the MICRO/PDP-11 system listed above is considered a field-replaceable unit (FRU). Chapter 5 gives the procedures used to isolate failures in the FRUs and the procedures for their removal and replacement.

2.2 KDF11-BP CENTRAL PROCESSING UNIT (CPU) ASSEMBLY

The KDF11-BP CPU includes a KDF11-BE (M8189) central processing unit module, a CPU patch and filter panel, and a CPU patch and filter panel cable that connects the two.

The KDF11-BE (M8189) is a quad-height module that occupies the first slot in the backplane. It consists of a central processing unit, a line frequency clock, boot/diagnostic ROMs, two serial line units (SLUs), and a memory management unit (MMU). Additional 40-pin sockets located on the module provide for the addition of an optional floating-point processor (FP) chip or a commercial instruction set (CIS) chip.

The KDF11-BE module uses the extended LSI-11 bus (22-bit addressing) with 4-level interrupt bus protocol, and supports up to four megabytes of memory.

The KDF11-BE module contains numerous jumpers and two dual in-line package (DIP) switch units, S1(E102) and S2(E114), that allow you to select various module features. The locations of these switches and jumpers, as well as those of the diagnostic LEDs, are shown in Figure 2-1. The jumpers allow reconfiguration of the module for various applications. The factory jumper configuration is listed in Table 2-1.

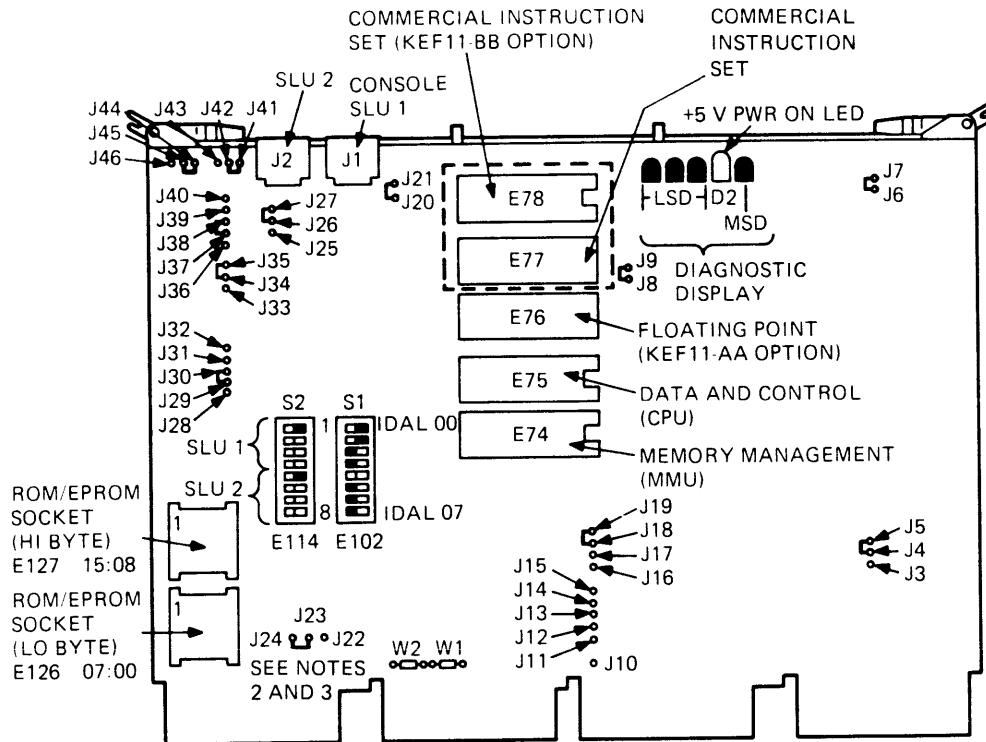

- NOTES:
1. INSTALLED JUMPERS SHOW THE MICRO/PDP-11 CONFIGURATION.
 2. WHEN 8 K EPROMS OR 8 K MASKED ROMS ARE USED, J23 IS CONNECTED TO J24.
 3. WHEN 2 K EPROMS ARE USED, J23 IS CONNECTED TO J22. WHEN 2 K MASKED ROMS ARE USED, J23 IS CONNECTED TO J24.

MR-10273

Figure 2-1 KDF11-BE Module Jumper, Switch, and Diagnostic LED Locations

Table 2-1 KDF11-BE Module Factory Jumper Configuration

Jumpers*	Function
J4-J5	Disables the CPU halt feature from the console serial line unit (SLU) Break key on the terminal.
J6-J7	For manufacturing use only; must be installed for normal operation.
J8-J9	For manufacturing use only; must be installed for normal operation.
J18-J19	CPU power-up mode: bootstrap from location 773000.
J20-J21	For manufacturing use only; must be installed for normal operation.
J23-J24+	In for use of 8 K masked ROMs or 8 K EPROMS. (J22-J23 must be removed.)
J26-J27	Connects the output of the console serial line drive to the serial line.
J29-J30	One stop bit for the console SLU port.
J34-J35	Connects LINMF(1)H to the SLU UART reset input.
J37-J38	One stop bit for the second SLU port.
J41-J42+	Uses an external clock for the console SLU.
J44-J45+	Uses an external clock for the second SLU.
W1	Provides bus grant continuity for the BIAK signal.
W2	Provides bus grant continuity for the BDMG signal.

* All jumpers listed here are installed; all others on this module are removed.

+ Different from the jumper configuration used on the KDF11-BA (M8189) module used in the PDP-11/23+ system application.

The first switch unit (E102) consists of eight switches that are used to select one of various available bootstrap/diagnostic programs. The configuration for the bootstrap/diagnostic switch unit is listed in Table 2-2.

NOTE

In order for the boot/diagnostic ROMs to function correctly, the memory management unit (MMU) chip (part number 21-15542-01) must be installed on the KDF11-BE module. The MMU is provided with the KDF11-BE module.

Table 2-2 KDF11-BE Module Bootstrap/Diagnostic Switch Configuration – Switch S1(E102)

Switch Position								Function
8	7	6	5	4	3	2	1	
X	X	0	0	0	0	0	0	Inhibit power-on auto-sequence boot.
0	X	X	X	X	X	X	X	Console terminal is not an ANSI mode video terminal.
1	X	X	X	X	X	X	X*	Console terminal is an ANSI mode video terminal.
X	0	X	X	X	X	X	X	Inhibit quick verify memory diagnostic.
X	1	X	X	X	X	X	X*	Execute quick verify memory diagnostic.
X	X	0	0	0	0	1	0	Select TU58 device 0.
X	X	0	0	0	0	1	1	Select TU58 device 1.
X	X	0	0	0	1	0	0	Select RX01 device 0.
X	X	0	0	0	1	0	1	Select RX01 device 1.
X	X	0	0	0	1	1	0	Select RX02 device 0.
X	X	0	0	0	1	1	1	Select RX02 device 1.
X	X	0	0	1	0	0	0	Select MSCP device 0.
X	X	0	0	1	0	0	1	Select MSCP device 1.
X	X	0	0	1	0	1	0	Select MSCP device 2.
X	X	0	0	1	0	1	1	Select MSCP device 3.
X	X	0	0	1	1	0	0	Select MSCP device 4.
X	X	0	0	1	1	0	1	Select MSCP device 5.
X	X	0	0	1	1	1	0	Select MSCP device 6.

**Table 2-2 KDF11-BE Module Bootstrap/Diagnostic
Switch Configuration – Switch S1(E102) (Cont)**

Switch Position								Function
8	7	6	5	4	3	2	1	
X	X	0	0	1	1	1	1*	Select MSCP auto-boot.
X	X	0	1	0	0	0	0	Select RL01/RL02 device 0.
X	X	0	1	0	0	0	1	Select RL01/RL02 device 1.
X	X	0	1	0	0	1	0	Select RL01/RL02 device 2.
X	X	0	1	0	0	1	1	Select RL01/RL02 device 3.
X	X	0	1	1	0	0	0	Reserved for future addresses.
X	X	1	1	0	1	1	1	
X	X	1	1	1	0	0	0	Select DECnet DUV11.
X	X	1	1	1	0	0	1	Select DECnet DLV11-E.
X	X	1	1	1	0	1	0	Select DECnet DLV11-F.
X	0	1	1	1	1	1	1	Loop selftest but do not execute memory diagnostic.
X	1	1	1	1	1	1	1	Loop selftest and memory diagnostic.

0 = Off

1 = On

X = Don't care

* The MICRO/PDP-11 system is shipped with switches S1-1, S1-2, S1-3, S1-4, S1-7, and S1-8 on. Switches S1-5 and S1-6 are off.

As indicated in Table 2-2, the format for switch S1 is as follows.

- When bits 6 through 4 are used to identify the controller type, bits 3 through 1 identify the unit number.
- When bits 6 through 3 are used to identify the controller type, bits 2 and 1 identify the unit number.
- When bits 6 through 2 are used to identify the controller type, bit 1 identifies the unit number.
- When bits 6 through 4 are all 1s (the DECnet identifier), bits 3 through 1 identify the link type.
- When bits 6 through 1 are all 1s, the selftest loops, and bit 7 determines if the memory diagnostic is to be included.

All undefined switch configurations will cause an error message to be displayed and the console terminal to respond to on-line debugging technique (ODT) commands.

The second switch (E114) also consists of eight switches and selects the baud rates for the console terminal SLU and the second SLU. The factory configuration for the baud rate switch unit is listed in Table 2-3. In the MICRO/PDP-11 system, this switch unit (E114) is disabled by inserting jumpers J41-J42 and J44-J45 (as listed in Table 2-1). These jumpers are used to select an external clock to control the SLUs. The external source of the clock is discussed below.

NOTE

Table 2-3 shows the factory configuration for switch S2. The MICRO/PDP-11 system provides you with external switches on the patch and filter panel (see Table 2-4) for use in changing the baud rates of these SLUs.

Table 2-3 KDF11-BE Module SLU Baud Rate Factory Switch Configuration - Switch S2(E114)

Switch Number	Switch Position	Function
1	On	Console terminal SLU set for 9600 baud.
2	Off	
3	Off	
4	Off	
5	On	Second SLU set for 9600 baud.
6	Off	
7	Off	
8	Off	

The -BP designation of the KDF11 CPU indicates that the cable and the patch and filter panel that connect to the CPU are included. The CPU's patch and filter panel provides simple and convenient means of interfacing a console terminal, as well as a second SLU, to the KDF11-BE module. The panel also provides two rotary switches that allow you to change the baud rates for the two devices without the need to change switch positions on the M8189 module.

The CPU patch and filter panel is mounted in the patch and filter panel assembly, located under the rear plastic cover of the system unit. The patch and filter panel assembly is described in Paragraph 2.6.4. Figure 2-2 shows the CPU patch and filter panel and the locations of the rotary switches. Table 2-4 defines the rotary switch settings and the corresponding baud rates.

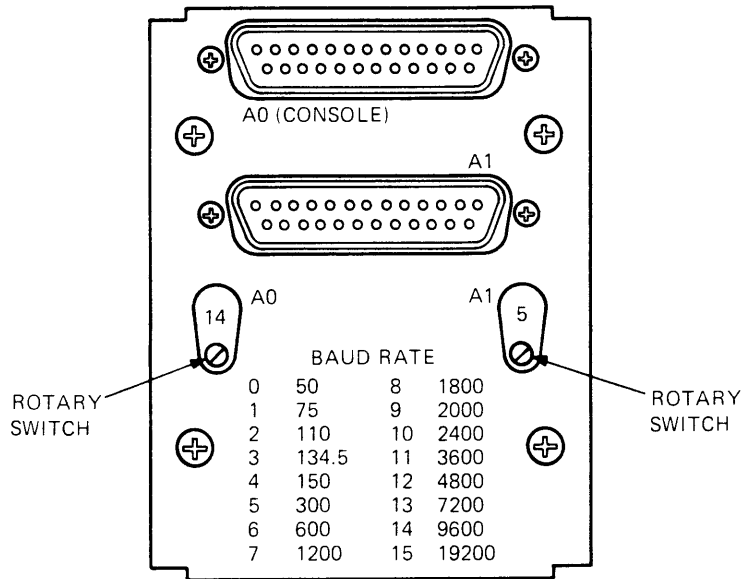

MR-9407

Figure 2-2 CPU Patch and Filter Panel

**Table 2-4 CPU Patch and Filter Panel
Rotary Switch Settings**

Switch Position	Baud Rate Selected
0	50
1	75
2	110
3	134.5
4	150
5	300
6	600
7	1200
8	1800
9	2000
10	2400
11	3600
12	4800
13	7200
14	9600
15	19200

The KDF11-BE module also contains five LEDs that provide status information about the module. The large green LED indicates that +5 V is present on the module. The other four LEDs are used for error detection. Table 5-4 lists the error codes provided by these LEDs. The backplane pin assignments for the KDF11-BE module are listed in Appendix A. You can obtain more detailed information on the KDF11-BE CPU module from the *KDF11-BA CPU Module User's Guide*, (EK-KDFEB-UG).

2.3 MSV11-PK MEMORY MODULE

The MSV11-PK memory (M8067) is a quad-height module that provides 256 K bytes of storage and occupies the backplane slot adjacent to the KDF11-BE CPU module. The MSV11-PK module is designed to be used with the extended LSI-11 bus (22-bit addressing), and contains a metallic oxide semiconductor (MOS) random-access memory (RAM). The MSV11-PK module provides storage for 18-bit words, each made up of 16 data bits and 2 parity bits. The module also contains parity control circuitry for byte parity generation and checking, and a control and status register (CSR). Two LEDs indicate module status: the green LED indicates the presence of +5 V on the module, the red LED indicates the detection of a parity error.

Additional memory modules are available as options for system expansion. Each memory module added to a system must be reconfigured by repositioning jumpers on the module's wirewrap stakes. The factory configuration for these jumpers is shown in Figure 2-3 and listed in Table 2-5. Refer to Chapter 6 for jumper relocation information for added memory modules. Backplane pin assignments for the MSV11-PK module are provided in Appendix A. You can obtain more detailed information on the MSV11-PK memory module from the *MSV11-PK User's Guide* (EK-MSVOP-UG).

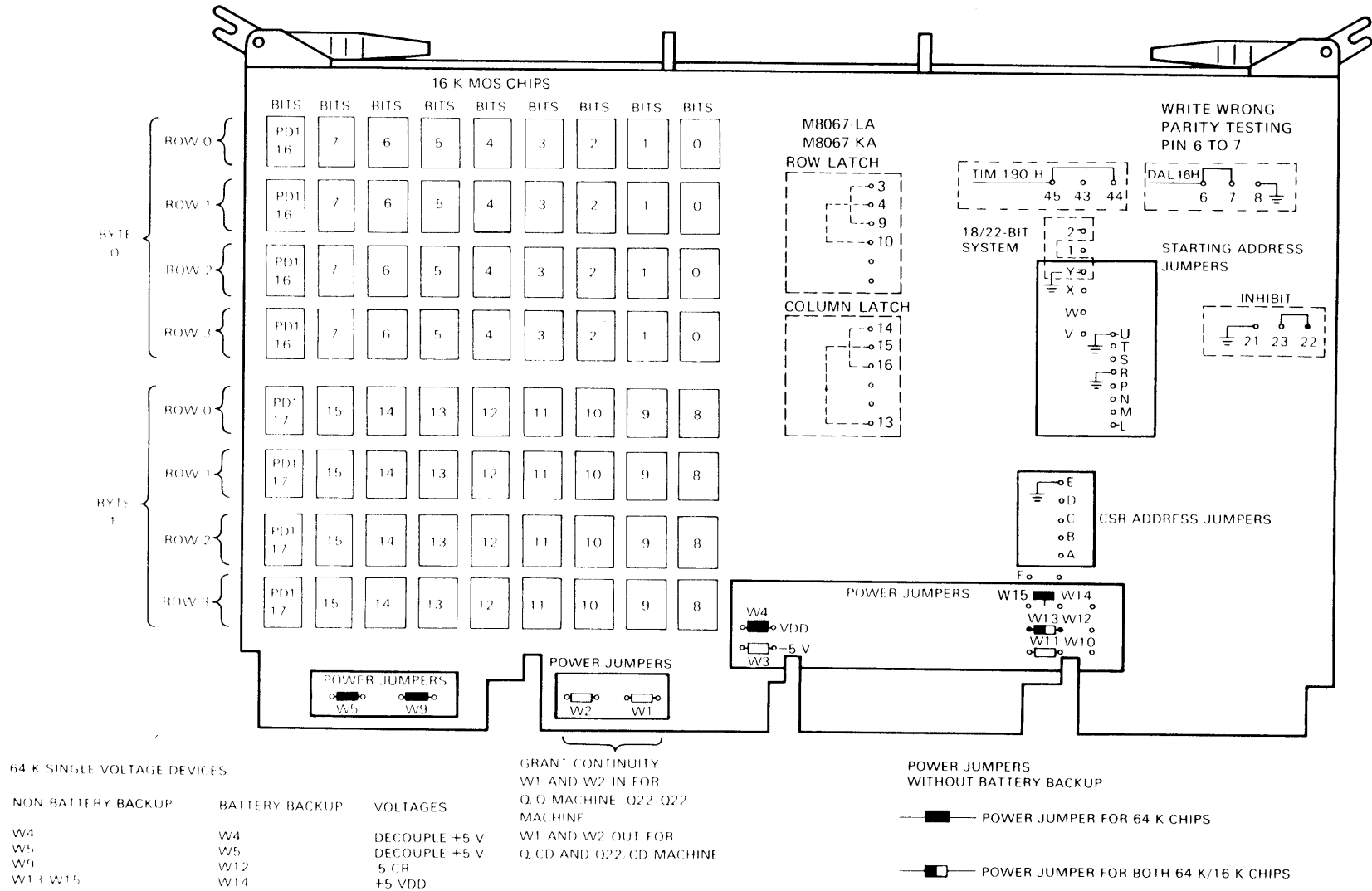

Figure 2-3 MSV11-PK Memory Module Factory Jumper Configuration

Table 2-5 MSV11-PK Memory Module Factory Jumper Configuration

Jumper	State	Function	
W1	I	Grant continuity	
W2	I	Grant continuity	
W3	R	Power jumper, -5 V	
W4	I	Power jumper, decoupler +5 V	
W5	I	Power jumper, decoupler +5 V	
W9	I	Power jumper	
W10	R	Power jumper	
W11	R	Power jumper	
W12	R	Power jumper	
W13	I	Power jumper	
W14	R	Power jumper	
W15	I	Power jumper	
3 to 9	I	Row latch - 64 K MOS chip	
4 to 10	I	Row latch - 64 K MOS chip	
6 to 7	I	Write wrong parity	
8, 21	R	Ground	
13 to 15	I	Column latch - 64 K MOS chip	
14 to 16	I	Column latch - 64 K MOS chip	
22 to 23	I	Inhibit	
44 to 45	I	Multiple voltage MOS RAM access time	
A to E	R	CSR address bits	
B to E	R		
C to E	R		
D to E	R		
E	*		
L to R	R		Starting address bits
M to R	R		
N to R	R		
P to R	R		
R	*		
S to U	R		
T to U	R		
U	*		
V to Y	R		
W to Y	R		
X to Y	R		
Y	*		

2.4 DZV11-CP ASYNCHRONOUS MULTIPLEXER

The DZV11-CP asynchronous multiplexer includes a DZV11-A (M7957) asynchronous multiplexer module, a patch and filter panel, and a cable that connects the panel and module.

The DZV11-A asynchronous multiplexer is a quad-height module that occupies the backplane slot adjacent to the last memory module on the SX-RA500-EX and SX-RA500-FA models of the MICRO/PDP-11 system. (Refer to Table 1-1.) The DZV11-A module is an option on all other models. This module, together with the patch and filter panel, provides an interface between the LSI-11 bus and up to four asynchronous serial data communication channels.

The DZV11-A module provides EIA interface levels and enough data set control to permit dial-up (auto-answer) operation with modems using full-duplex operations.

There are 16 jumpers and 2 DIP switches on the DZV11-A module. These are used to change the operation of the module for various applications. The locations of these jumpers and switches is shown in Figure 2-4. The factory jumper configuration and the factory switch settings are listed in Tables 2-6 and 2-7, respectively.

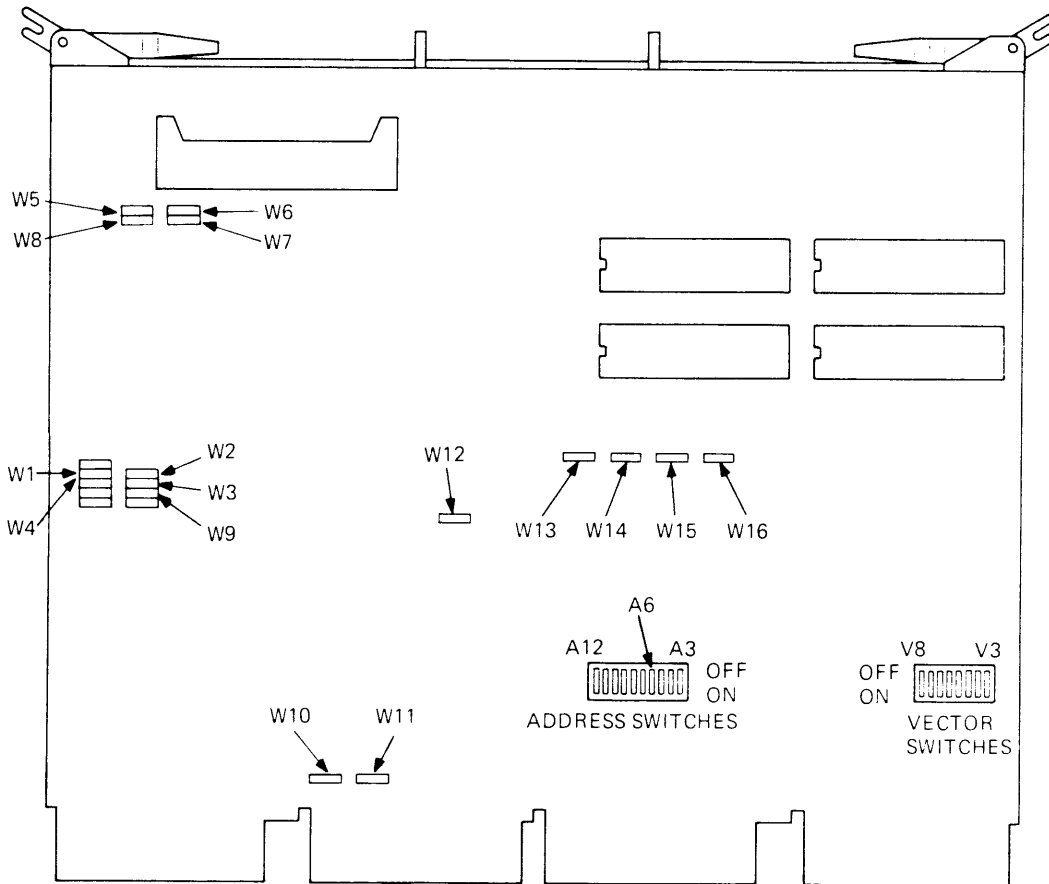

NOTES:

1. JUMPERS W9, W12, W13, W14, W15, AND W16 ARE REMOVED ONLY FOR MANUFACTURING TESTS. THEY SHOULD NOT BE REMOVED IN THE FIELD.
2. JUMPERS W10 AND W11 ARE IN FOR Q/Q AND Q22/Q22 MACHINES AND ARE OUT FOR Q/CD AND Q22/CD MACHINES. THEY PROVIDE GRANT CONTINUITY.

Figure 2-4 DZV11-A Module Jumper and Switch Locations

M7957

Table 2-6 DZV11-A Module Factory Jumper Configuration

Jumper	State	Line	Function
W1	R	03	These four jumpers connect the data terminal ready (DTR) signal to the request to send (RTS) signal.
W2	R	03	
W3	R	01	
W4	R	00	
W5	R	03	These four jumpers connect the forced busy (FB) signal to the request to send (RTS) signal.
W6	R	02	
W7	R	01	
W8	R	00	
W9	I	-	These eight jumpers supply LSI-11 bus signals.
W10	I*	-	
W11	I*	-	
W12	I	-	
W13	I	-	
W14	I	-	
W15	I	-	
W16	I	-	

I = Installed

R = Removed

* These jumpers would be removed if the module were to be installed in a Q/CD slot of the backplane. (Figure 2-10 shows the locations of the Q/CD backplane slots.)

Table 2-7 DZV11-A Module Factory Switch Settings

Number	Switch	Position
Address Switch Selection (160100)		
A3	10	Off
A4	9	Off
A5	8	Off
A6	7	On
A7	6	Off
A8	5	Off
A9	4	Off
A10	3	Off
A11	2	Off
A12	1	Off
Vector Switch Selection (310)		
V3	6	On
V4	5	Off
V5	4	Off
V6	3	On
V7	2	On
V8	1	Off

The -CP suffix of the DZV11 asynchronous multiplexer also includes a cable and a patch and filter panel that provide a convenient means of interfacing terminals to the DZV11. The DZV11 patch and filter panel is mounted in the patch and filter assembly, located under the rear plastic cover of the system unit. The patch and filter panel assembly is described in Paragraph 2.6.4. The DZV11 patch and filter panel is shown in Figure 2-5.

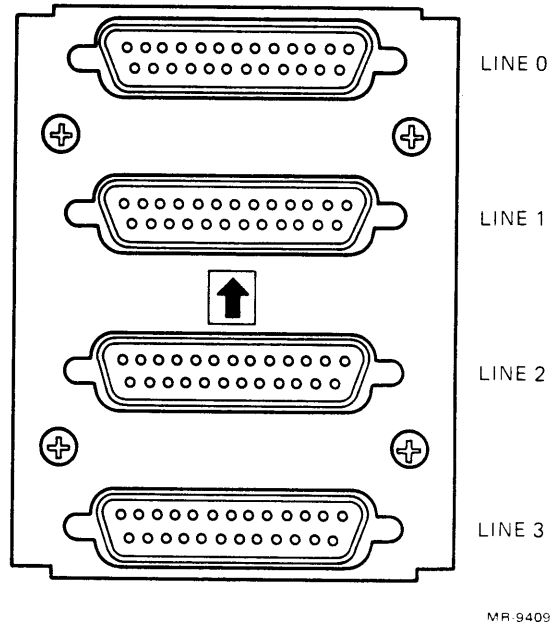

Figure 2-5 DZV11 Patch and Filter Panel

Backplane pin assignments for the DZV11-A module are listed in Appendix A. Refer to Chapter 6 for expansion information. You can obtain more detailed information on the DZV11-A module from the *DZV11 Asynchronous Multiplexer Technical Manual (EK-DZV11-TM)*.

2.5 RD51/RX50 CONTROLLER AND DRIVE SUBSYSTEM

The RD51/RX50 controller and drive subsystem includes the RQDX1 controller module, an RD51 fixed disk drive, and an RX50 diskette drive.

2.5.1 RQDX1 Controller Module

The RQDX1 controller (M8639) is a quad-height module that is mounted in the last occupied slot in the backplane. It is a high-functionality disk controller that interfaces the RD51 fixed disk drive and the RX50 diskette drive to the extended LSI-11 bus. The controller is a direct memory access (DMA) type of interface and conforms to mass storage control protocol (MSCP). Figure 2-6 shows the RQDX1 controller module's jumper and LED locations, and Table 2-8 lists the factory jumper configurations. A cable (part number BC06L-1C) connects the RQDX1 controller module to the signal distribution printed circuit board, where the signals are distributed to the individual drives. Additional information is provided in the *RQDX1 Controller Module User's Guide (EK-RQDX1-UG)*.

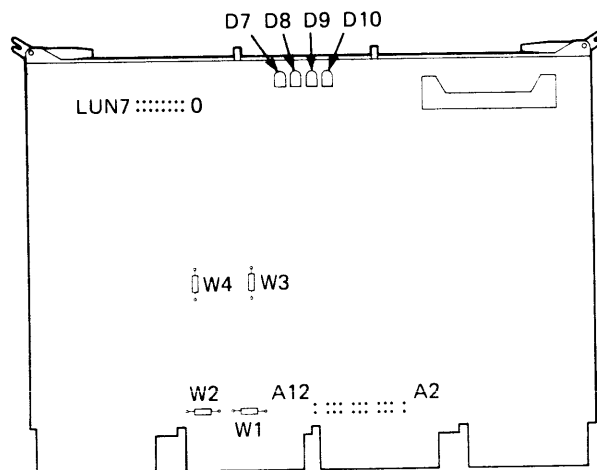

NOTES:

1. ADDRESS SELECTION (A12 THROUGH A2) AND LOGICAL UNIT NUMBER SELECTION (LUN7 THROUGH LUN0) IS MADE BY ATTACHING TWO POSITION JUMPER CLIPS (PART NO. 12-18783-00). THIS ELIMINATES THE NEED TO WIRE WRAP JUMPERS ONTO THE ADDRESS OR LOGICAL UNIT NUMBER STAKES.
2. JUMPERS W1 AND W2 ARE IN FOR Q/Q AND Q22/Q22 MACHINES AND ARE OUT FOR Q/CD AND Q22/CD MACHINES. THEY PROVIDE GRANT CONTINUITY.

MR-9915

Figure 2-6 RQDX1 Controller Module Jumper and LED Locations

**Table 2-8 RQDX1 Controller Module Factory
Jumper Configuration**

Jumper	State	
Address Selection (172150)		
A2	Out	
A3	In	
A4	Out	
A5	In	
A6	In	
A7	Out	
A8	Out	
A9	Out	
A10	In	
A11	Out	
A12	In	
Logical Unit Number (0)		
LUN1	Out	
LUN2	Out	
LUN3	Out	
LUN4	Out	
LUN5	Out	
LUN6	Out	
LUN7	Out	
LUN8	Out	
W1	In	These four jumpers are for manufacturing use only.
W2	In	
W3	In	
W4	In	

2.5.2 RD51 Fixed Disk Drive

The RD51 fixed disk drive is a random-access storage device that uses two nonremovable 133.4 mm (5.25 in) disks as storage media. Each disk surface uses one movable head to service 306 data tracks. The total formatted capacity of the 4 heads and surfaces is 11 megabytes. The RD51 fixed disk drive is shown in Figure 2-7.

NOTE

When replacing the RD51 fixed disk drive with a spare unit, the spare must be reformatted before running diagnostics or using the RD51 fixed disk drive.

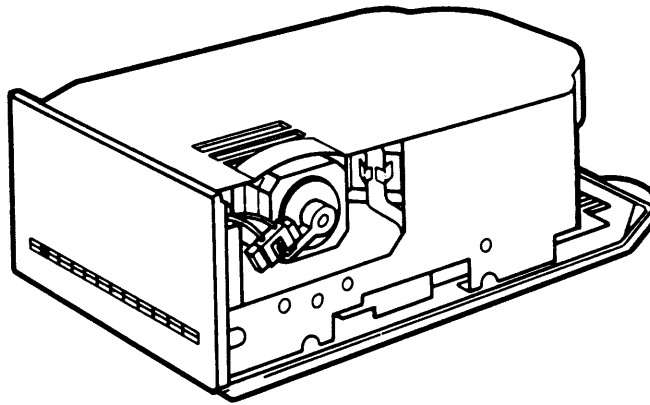

MR-9408

Figure 2-7 RD51 Fixed Disk Drive

The RD51 fixed disk drive is an FRU contained in the BA23-A mounting box. Two cables (part numbers 17-00282-00 and 17-00285-00) connect the RD51 fixed disk drive to the RQDX1 controller module. Another cable (part number 70-20435-1K) connects the RD51 fixed disk drive (and the RX50 diskette drive) to the power supply.

2.5.3 RX50 Diskette Drive

The RX50 diskette drive is a random-access, dual-diskette storage device that uses two single-sided 133.4 mm (5.25 in) RX50K diskettes. The device's total drive capacity is 800 K bytes of formatted data. It has two access doors and slots for diskette insertion and removal. An active drive light for each diskette slot informs you when that drive is busy.

The RX50 diskette drive is an FRU contained in the BA23-A mounting box. One cable (part number 17-00285-02) connects the RX50 diskette drive to the RQDX1 controller module. Another cable (part number 70-20435-1K) connects the RX50 diskette drive (and the RD51 fixed disk drive) to the power supply.

Because the RX50 diskette drive is considered an FRU, no adjustment or alignment procedures are provided. The RX50 diskette drive, shown in Figure 2-8, is adjusted and aligned at the time of manufacture.

NOTE

If the system is being moved, it is recommended that the cardboard shipping insert be installed, if one was used initially, to prevent damage to the RX50 diskette drive's read/write heads.

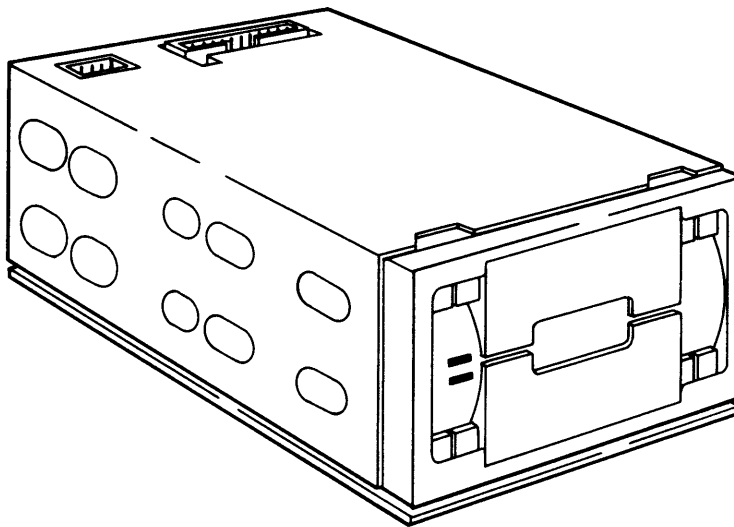

MR-9532

Figure 2-8 RX50 Diskette Drive

2.6 BA23-A MOUNTING BOX

The BA23-A mounting box contains two dc fans, an H9278-A backplane with a card frame assembly, an H7864 power supply, a control panel (54-15610), and a patch and filter panel assembly. The BA23-A mounting box is shown in Figure 2-9.

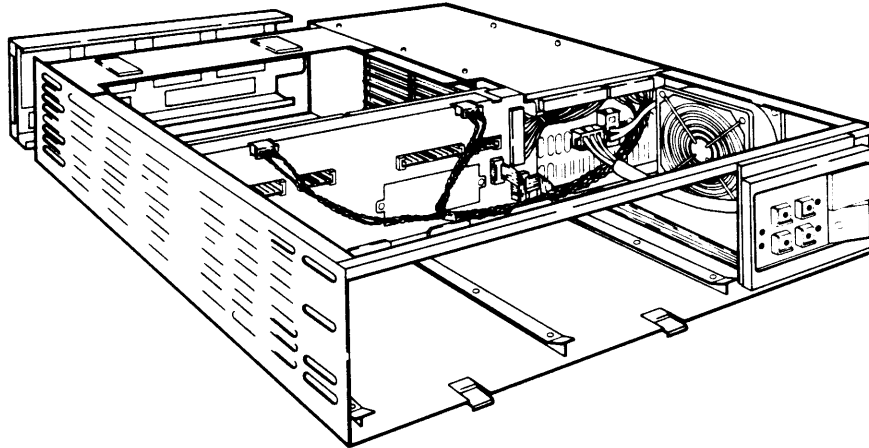

MR-9543

Figure 2-9 BA23-A Mounting Box

The BA23-A mounting box may be purchased as a separate unit and is available in two models. The BA23A-AR is the rack mount model, with front plastic cover and sleeves. The BA23A-AF is the floor mount model, with front and rear plastic covers, sides, and a pedestal base. The floor mount model is easily converted for tabletop use by removing the pedestal base and installing four rubber feet. The BA23-A mounting box does not include: power cord, disk(ette) drives, patch and filter panels, documentation, or any modules mounted in the backplane.

2.6.1 Backplane Assembly

The MICRO/PDP-11 system uses an 8-slot H9278-A backplane for mounting both dual- and quad-height modules. (The modules must be extended LSI-11 bus-compatible). As shown in Figure 2-10, connectors A and B of each backplane slot supply Q22 bus (that is, extended LSI-11 bus) signals to the modules. The C and D connectors of slots 1, 2, and 3 provide an interconnection between the three slots. This interconnection is referred to as the CD bus. The five remaining backplane slots (slots 4 through 8) provide the same Q22 bus signals on the C and D connectors as those supplied on the A and B connectors. The backplane's grant continuity chaining is shown in Figure 2-11.

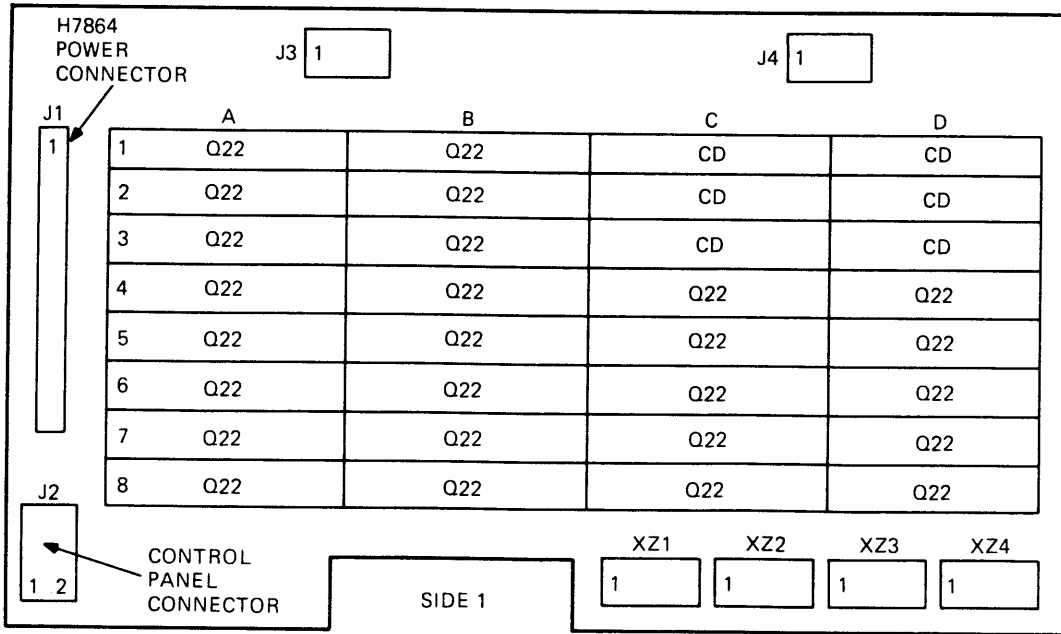

- NOTES:
- CONNECTORS J1, J2, J3, AND J4 ARE MOUNTED ON SIDE 2.
 - XZ1-4 ARE BACKPLANE TERMINATOR SOCKETS. THE SIP TERMINATION RESISTORS MOUNTED IN XZ1-4 MUST BE REMOVED WHEN EXPANDING BEYOND THIS BACKPLANE.
 - J3 AND J4 ARE NOT POWER SOURCES. THEY ARE USED TO SUPPLY POWER TO THE BACKPLANE WHEN THE RD51-A FIXED DISK DRIVE OR RX50-AA DISKETTE DRIVE IS NOT INSTALLED.

Figure 2-10 Backplane

MR-11887

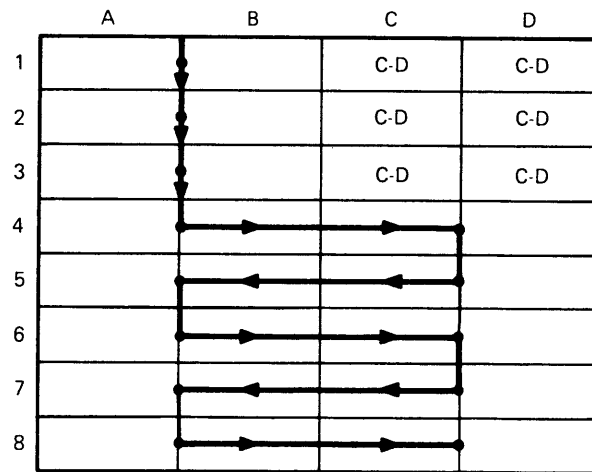

- NOTE:
- C+D (1-3) = CD INTERCONNECT
 - OTHERS = Q22 FORMAT

MR-9416

Figure 2-11 Backplane Grant Continuity Chaining

The backplane is attached to a signal distribution printed circuit board, which provides connectors for the fixed disk drive, diskette drive, RQDX1 controller module, and control panel cables. Figure 2-12 shows the layout of the signal distribution printed circuit board.

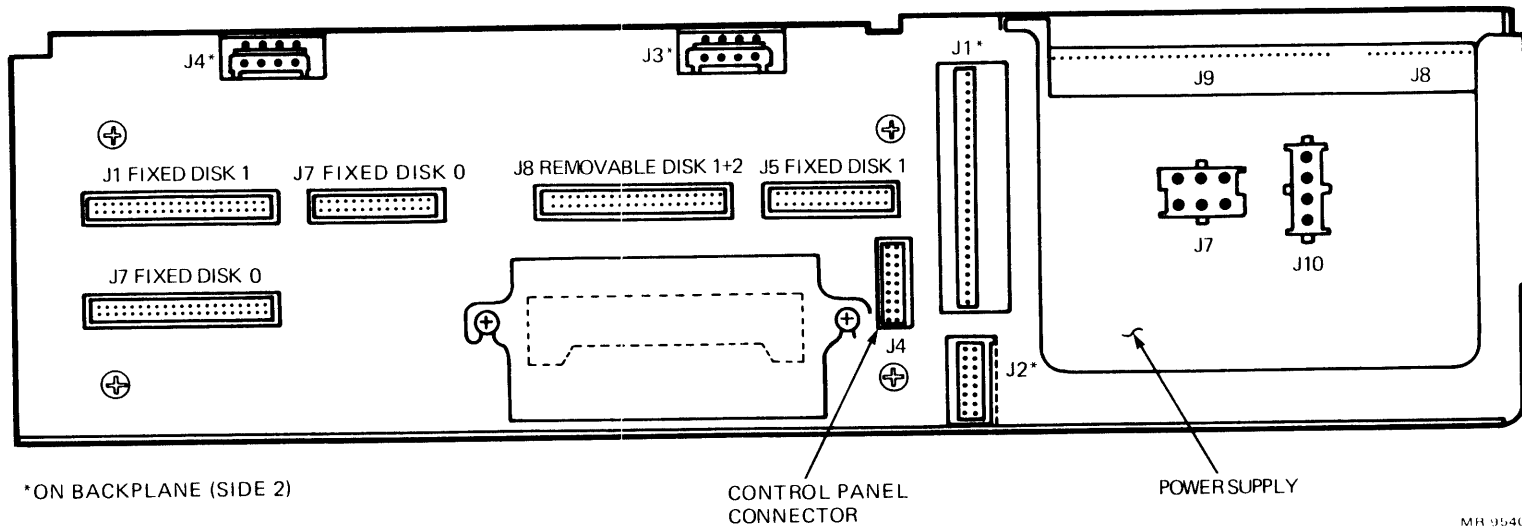
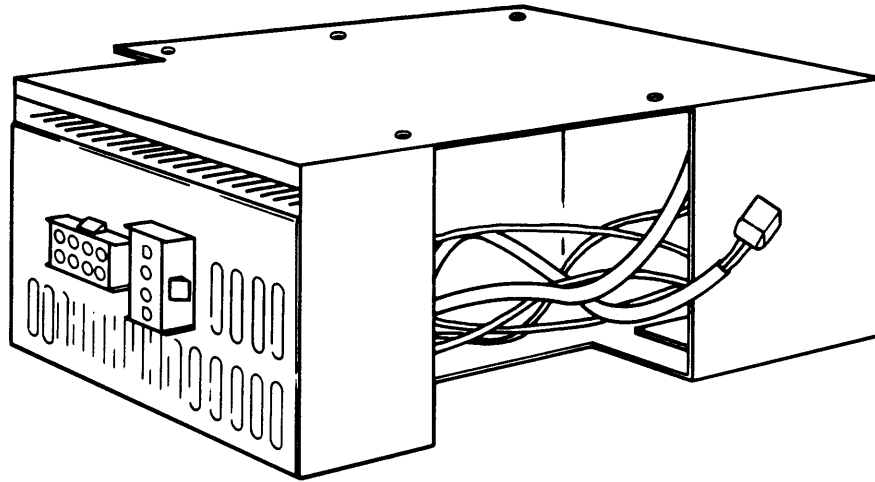

Figure 2-12 Signal Distribution Printed Circuit Board Layout

2.6.2 H7864 Power Supply

The H7864 power supply, shown in Figure 2-13, supplies fixed (nonadjustable) voltages of +5 V and +12 V to the backplane of the MICRO/PDP-11 system. The power supply also provides these voltages to the fixed disk drive and diskette drive installed in the mounting box. Two brushless dc fans are driven by the H7864 power supply; one fan cools the logic modules and power supply, the other fan cools the fixed disk drive and diskette drive.



MR-9536

Figure 2-13 H7864 Power Supply

The H7864 power supply also supplies three system control signals to the backplane of the MICRO/PDP-11 system. Two of these signals, BDCOK H and BPOK H, are asserted when system power is stable. The third signal, BEVENT L, is an external line clock interrupt request to the CPU.

2.6.3 Control Panel (54-15610)

The MICRO/PDP-11 system control panel, shown in Figure 2-14, consists of a printed circuit board equipped with switches and LEDs. This printed circuit board also provides test points for +5 V and +12 V.

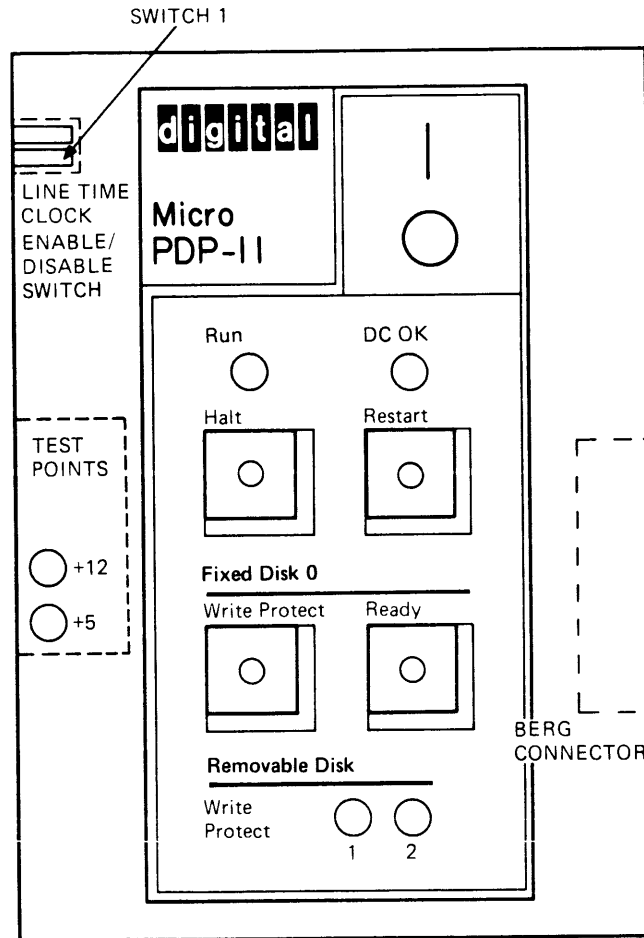

MR-9417

Figure 2-14 Control Panel Assembly

The 2-position line time clock (LTC) switch (switch 1) is used to enable or disable the LTC function. Setting switch 1 on enables the LTC to function under software control. Setting switch 1 to the off position disables the LTC function. The other 2-position switch (switch 2) is not used.

The remaining control panel switches and indicators are defined in Tables 1-2 and 1-3.

2.6.4 Patch and Filter Panel Assembly

The MICRO/PDP-11 system patch and filter panel assembly is located behind the rear plastic cover of the system unit. (Rack mount units do not have a rear plastic cover over this assembly.) The assembly provides for the mounting of up to four patch and filter panels, such as those for the CPU (described in Paragraph 2.2) and the DZV11 asynchronous multiplexer (described in Paragraph 2.4). A removable division between two of the patch and filter panel spaces allows for the installation of a large panel. The assembly also provides space to accommodate two 50-pin connectors in the event that the system is expanded. Metal plates are mounted in unoccupied panel and connector spaces; these can be easily removed for panel or connector installation. Figure 2-15 shows the patch and filter panel assembly.

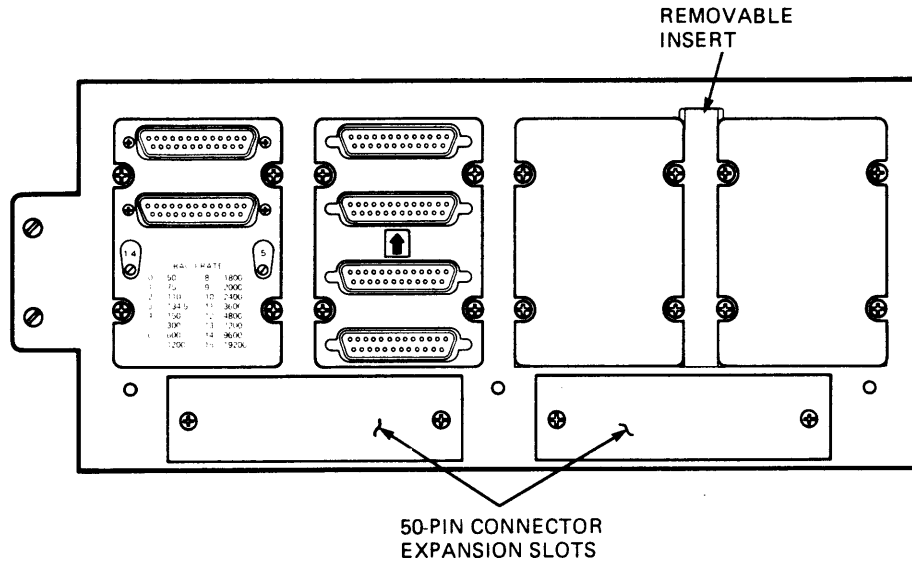

MR-9529

Figure 2-15 Patch and Filter Panel Assembly

CHAPTER 3 PROGRAMMING

3.1 INTRODUCTION

The MICRO/PDP-11 system hardware runs several small ROM-based diagnostic programs when the system is powered up. Depending on the results of this process, you may use the bootstrap function provided in the hardware to run one of the two types of software used on the MICRO/PDP-11 system.

The first type of software is made up of the system diagnostic programs, which are all included on the diagnostic diskettes provided with the systems that include the Installation Accessories Box. (Refer to Table 1-1.) The Installation Accessories Box includes a user test diskette and a set of Field Service test diskettes. The user test diskette incorporates the DEC/X11 program modules necessary to test the MICRO/PDP-11 as a system, as well as the appropriate XXDP+ series of diagnostic programs necessary to test the components of the system. The Field Service test diskettes are a more complex means of testing the system and require some knowledge of XXDP+ commands.

The second type of software is made up of the operating system. A wide variety of highly functional operating system software and business application programs is available for use with the MICRO/PDP-11 system. Existing PDP-11 system software supported by the MICRO/PDP-11 system includes RT-11, RSX-11M, RSX11-M-PLUS, Micro/RSTS, and CTS-300.

3.2 HARDWARE-INITIATED DIAGNOSTICS

Each time the MICRO/PDP-11 system is switched on, a series of tests is performed automatically (provided that switch 1 on the KDF11-BE module is configured as defined in Table 2-2). These tests are provided by ROMs located on the KDF11-BE (M8189) module. They quickly verify that the MICRO/PDP-11 system is working properly. A complete listing of the contents of the KDF11-BE module's boot/diagnostic ROMs is available in the CZKDFA0 KDF11-BE BOOT ROM listing (AC-T577A-MC) or microfiche listing (AH-T578A-MC). You can run additional, more complete, system tests by using the diagnostic software.

A successful completion of the hardware-initiated diagnostics results in the following message being displayed on the console terminal.

```
KDF11B-BE ROM V0.8

128KW MEMORY
9 STEP MEMORY TEST
STEP 1 2 3 4 5 6 7 8 9
TOTAL MEMORY ERRORS = 0
CLOCK ENABLED
```

The version number may differ from that listed above to reflect the particular version of the ROMs installed on the CPU printed circuit board in your system. The second line of the message indicates how much memory is installed in the system. The message then indicates that a memory test is being performed, and reports the results of that test. The numbers 1 through 9 are displayed slowly, one at a time, as each step of the diagnostic program tests the system memory. The last line of the message indicates that the line time clock (LTC) is enabled on the system. (To set the LTC switch, refer to Paragraph 2.6.3.)

If an error occurs, a different message is displayed on the console terminal. (Chapter 5 gives examples of error printouts and their meanings.)

If the terminal used is not an ANSI terminal, the console displays 6n twice. (This is only an indication of the type of terminal being used.) If the terminal is an ANSI hard-copy terminal, it performs two line feed functions before it proceeds to the next message. Finally, if the terminal is an ANSI video terminal, it proceeds directly from the message listed above to the next message.

If bootable MSCP media is found on the MICRO/PDP-11 system at this time, the console terminal displays a message indicating which drive is booting. (This process is described in Paragraph 1.3.5.) If a bootable MSCP medium is not found on the system, an error (such as

Error 16 - not bootable

or

Error 17 - no disk

is reported, and you are given the opportunity to insert a diskette and reboot. (This process is also described in Paragraph 1.3.5.)

If you choose not to reboot (by responding to the reboot question by typing N and pressing the **Return** key), the system displays a list of commands.

If you are using an ANSI console terminal, the following message is displayed.

128 KW MEMORY KDF11B-BE ROM V06X CLOCK ENABLED

MAIN MENU

BOOT
HELP
MAP
DIAGNOSE

Press RETURN to select BOOT

Use cursor controls "UP ARROW" or "DOWN ARROW" to select function

Use CTRL/W to reset menu

If you are using a non-ANSI terminal and do not wish to reboot, the following message is displayed.

Type ? for HELP
Enter one of [Boot, Diagnose, Help, List, Map]:

The functions performed by these commands (on both ANSI and non-ANSI terminals) are listed below.

Boot – Loads a program from the selected storage medium.

Help – Prints the list of possible commands and their functions.

Map – Executes the system mapping routine. This routine displays the following information on the console terminal.

1. The CPU options installed on the KDF11-BE module.
 - a. Extended instruction set (EIS) – standard on the MICRO/PDP-11 system
 - b. Commercial instruction set (CIS)
 - c. Floating-point instruction set (FIS).

CIS and FIS are microcode options (MOS chips) that may be added to the KDF11-BE module.
2. The memory starting and ending addresses found on the system. The process of displaying this information takes about two minutes and can be aborted by entering a CTRL/C.
3. The range of I/O page addresses found on the system. The type of device associated with each address is not identified, however.

Diagnose – Executes an extended memory test. This test is more comprehensive than the one that takes place automatically whenever the system is powered up. This test, therefore, takes longer to be performed (approximately 25 minutes for 128 K words of memory).

List (on non-ANSI terminals) – Prints a list of bootable devices present on the system. (This function is part of the bootstrap command on ANSI terminals.)

3.3 DIAGNOSTIC SOFTWARE

Diagnostic programs determine whether or not the system is working properly; and if it is not, they isolate the failing component. Diagnostic programs are used exclusively for maintenance purposes and play no part in normal system operation. The programs are provided on the diagnostic diskettes included in the Installation Accessories Box. The MICRO/PDP-11 system designations that include the Installation Accessories Box are indicated in Table 1-1.

The user test diskette provides a convenient means for a user with no background in diagnostic software systems to quickly verify that their MICRO/PDP-11 systems are operating properly. This diskette is included in both the working kit and the master kit portions of the MICRO/PDP-11 system Installation Accessories Box. The diskette uses a diagnostic software system called DEC/X11. DEC/X11 is used primarily to check the reliability of the MICRO/PDP-11 system as a whole. The diskette also utilizes XXDP+, a software system complete with its own monitor and utility programs, as well as a collection of diagnostic programs. These programs are designed to test and diagnose the individual components that make up the MICRO/PDP-11 system. Paragraph 3.3.1 shows examples of how to use the user test diskette.

Field Service test diskettes are also provided with the MICRO/PDP-11 system. These four diskettes are provided in the master kit portion of the MICRO/PDP-11 system Installation Accessories Box. The diskettes provide the complete XXDP+ diagnostic software system. This system includes the standard XXDP+ monitor and utilities, as well as the elements necessary to build a run-time exerciser. Use of the Field Service test diskettes requires extensive knowledge of the XXDP+ software system. Chapter 5 gives information on the use of the Field Service test diskettes as troubleshooting tools.

3.3.1 User Test Diskette

The user test diskette features a modified version of XXDP+ software that allows you to test the field-replaceable units (FRUs) contained in the MICRO/PDP-11 system. This software will perform read-only testing of the RD51 fixed disk drive and RX50 diskette drive, and will not test options that have been added to the system. Once the user test diskette has been booted, the following main command menu appears on the console terminal.

```
**** MAIN COMMAND MENU **** V2.0 ****
```

What would you like?

- T - TEST your SYSTEM to see if it's O.K.
- I - INFORMATION on all COMMANDS.
- D - DESCRIPTION of your SYSTEM.
- H - HELP
- ? - HELP

Please type appropriate letter followed by "RETURN" key:

In order to test the system, type **T** and press the **Return** key. The system's user test monitor then automatically runs the appropriate DEC/X11 run-time exerciser present on the user test diskette, and supplies the following directions.

Directions:

Install a blank diskette in REMOVABLE DISK DRIVE #2.
Make sure that orange arrow on the diskette aligns with the orange bar on the drive.

The DZ test may print many unpredictable characters on any of the other terminals that are connected to this computer. So, if you do not want these characters to be printed on a certain terminal, please turn that terminal off now.

DO NOT TURN OFF THIS TERMINAL !

When the above has been completed proceed by typing the "RETURN" key.

Type "M" to return to MAIN COMMAND MENU or "RETURN" to proceed:

If you press the **Return** key, the following message is displayed.

The System Test is now running.

The System Test will run for approximately 10 minutes.
When testing has been completed, results of the test will appear on this terminal. DOTS will be displayed in a repeating pattern to show testing in progress.

.....

The series of dots is displayed to indicate that the diagnostic software is running. If the test is successfully completed, the following message appears.

Testing of this system is now complete. No errors have been detected. The system is O.K.

Check your OWNER'S MANUAL Software chapter on how to start User system software.

You are then directed to remove the user test diskette if testing of the system is complete. You may choose to retest the system by keeping the diskette installed and returning to the main command menu.

However, if an error occurs, a message different from the one above is displayed. Refer to Chapter 5 for examples of error printouts and their meanings.

3.3.2 Field Service Test Diskettes

A set of four Field Service test diskettes is provided with the MICRO/PDP-11 system. These diskettes are intended for use by a technician in order to test and/or troubleshoot the MICRO/PDP-11 system.

The Field Service test diskettes provide the standard XXDP+ diagnostic software system. XXDP+ includes the program modules necessary to build a run-time exerciser for the entire MICRO/PDP-11 system (including options that may have been added to expand it). Independent device diagnostics are also included with this XXDP+ software system. Chapter 5 gives information on the use of the Field Service test diskettes as troubleshooting tools.

3.4 OPERATING SYSTEM SOFTWARE

The operating system has two basic functions: it provides services for the development of application programs, and supplies the necessary environment in which application programs run. Micro/RXS, RSX-11M, RSX-11M-PLUS, Micro/RSTS, RT-11 (CTS-300 and MicroPower/Pascal™), V7M-11, and DSM-11 are operating systems that are supported by the MICRO/PDP-11 system. A brief description of each is given below. You can obtain additional information from the *PDP11 Software Handbook* (EB-18687-20).

3.4.1 Micro/RXS, RSX-11M, and RSX-11M-PLUS

The Micro/RXS, RSX-11M, and RSX-11M-PLUS operating systems are real-time multiprogramming and multiuser systems. They are designed to be compact, require little overhead, and can be generated to run in a variety of hardware and application environments. Applications range from small, dedicated, laboratory or industrial control systems, to large, multiuser, transaction-processing and information management systems. The RSX-11M operating system allows the use of high-level languages such as FORTRAN IV, FORTRAN 77, BASIC 11, BASIC PLUS-2, and COBOL.

3.4.2 Micro/RSTS

Micro/RSTS is an application-only, timesharing operating system. This system does not allow program development; it runs application programs that have been developed on Digital's RSTS/E operating system. The Micro/RSTS operating system is a subset of RSTS/E software, selected specifically for use on the MICRO/PDP-11 system's hardware configuration. Therefore, to do an application program for Micro/RSTS, you must have the larger RSTS/E system to code, compile, link, and debug the program.

3.4.3 RT-11

RT-11 is a compact operating system designed for real-time, single-user applications. This system supports the standard Digital Command Language (DCL). The RT-11 operating system is well suited to technical applications such as laboratory and factory instrument control, manufacturing process control, and similar tasks. Commercial applications of the RT-11 operating system include word processing, medical record management, and numerous others.

3.4.3.1 CTS-300 – CTS-300 is a layered operating system that is supported by the RT-11 operating system. The CTS-300 operating system provides additional facilities that include terminal handling and screen formatting, file handling, sort/merge, and print spooling. Programming is done with DIBOL. The operating system includes the DIBOL language compiler, three run-time systems on which DIBOL programs may be executed, and a number of utility programs.

3.4.3.2 MicroPower/Pascal – MicroPower/Pascal is a layered operating system that is supported by the RT-11 operating system. The MicroPower/Pascal operating system includes all the components needed to create concurrent, real-time application programs on a PDP-11 host system, and execute and debug applications on PDP-11 (QBus) microcomputer target systems. The application software developed through the use of the MicroPower/Pascal operating system is selectively combined with a library of executive service modules, thus eliminating the need for a general-purpose operating system. Pascal application programs execute standalone and do not run under any of Digital's operating systems.

3.4.4 V7M-11

V7M-11 systems are general-purpose, multiuser, interactive operating systems designed specifically to make the designer's, programmer's, and documenter's computing environment simple, efficient, flexible, and productive. V7M-11 is based on Bell Laboratories' UNIX* timesharing system, version 7, with enhancements for the MICRO/PDP-11 system. Applications include office automation, electronic mail, document preparation, data access, data collection, networking, software development, computer-aided design (CAD)/computer-aided manufacturing (CAM), and billing.

3.4.5 DSM-11

The DSM-11 operating system and DSM-11 programming language run together. (DSM includes MUMPS.) The MUMPS language is interpretive (each line of code is processed immediately upon being entered), so there are no compile and assembly steps. This is very useful in the scientific and health industries, where accessibility and timeliness of information are crucial.

CHAPTER 4 TERMINAL OPTIONS

4.1 INTRODUCTION

In order to use the MICRO/PDP-11 system, it must be connected to at least one of a variety of console terminals available. The KDF11-BE module contains a serial line unit that interfaces any of Digital's standard terminals via a standard EIA configuration (except for modem control). The selected terminal can be connected to the KDF11-BE module through the CPU patch and filter panel.

4.2 VT100 SERIES VIDEO TERMINALS

VT100 video display terminals feature a sculptured, typewriter-like, detachable keyboard. The keyboard attaches to the display unit by means of a 1.9 m (6 ft) coiled cord. A VT100 terminal, shown in Figure 4-1, operates on a full-duplex, asynchronous communication line, and is equipped with a standard EIA interface. A comparison of the various models within the VT100 series is shown in Figure 4-2. You can obtain detailed information on a terminal in the VT100 series by referring to that terminal's user's guide.

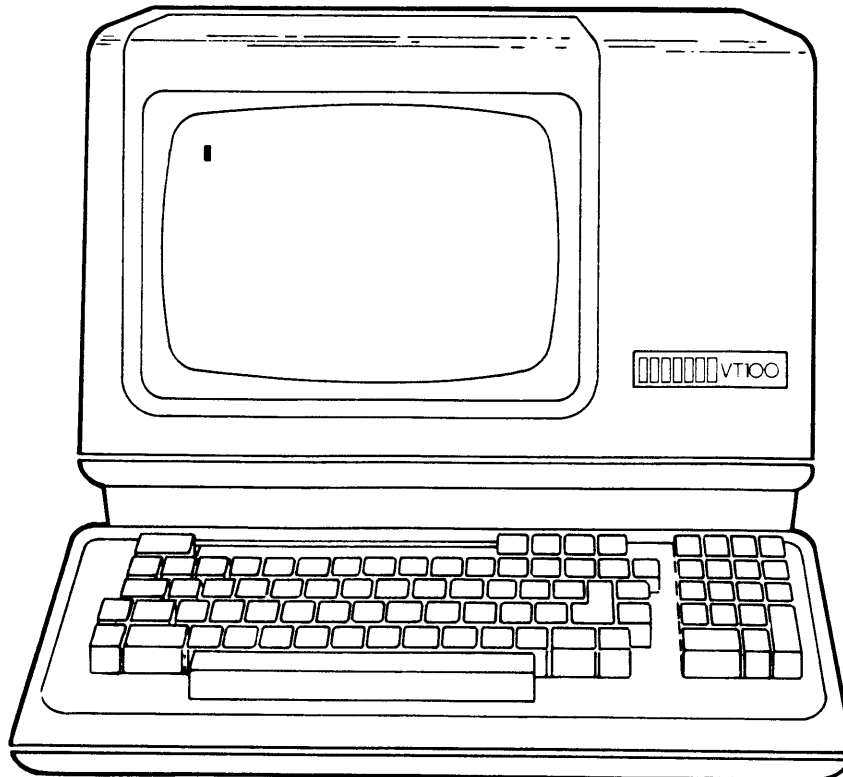

MR-3733

Figure 4-1 VT100 Terminal

MODEL	COL X LINES	COMMUNICATIONS	EDITING FEATURES	EXPANDABLE	GRAPHICS ²	PRINTER PORT ³	EUROPEAN FEATURES
VT100	80 X 24 132 X 10 132 X 24 WITH AVO OPTION ¹	<ul style="list-style-type: none"> • NO LOCAL ECHO • FULL DUPLEX 	OPTIONS <ul style="list-style-type: none"> • AVO 	YES	VT125 OPTION	OPTION	<ul style="list-style-type: none"> • NATIONAL POWER CORD • NATIONAL CHARACTER SET OPTION
VT101	80 X 24 132 X 10	<ul style="list-style-type: none"> • LOCAL ECHO 	OPTIONS <ul style="list-style-type: none"> • NONE 	NO	NO	NO	<ul style="list-style-type: none"> • NATIONAL POWER CORD • NATIONAL CHARACTER SET OPTION
VT102	80 X 24 132 X 24	<ul style="list-style-type: none"> • LOCAL ECHO • FULL HALF-DUPLEX • U.S. AND EUROPEAN MODEM CONTROLS 	STD <ul style="list-style-type: none"> • ADVANCED VIDEO OPTION • LINE INSERT/DELETE • CHARACTER INSERT/DELETE • WORD PROCESSING VARIATION (VT102W) SUPPORTS DECWORD 	NO	NO	STD	<ul style="list-style-type: none"> • NATIONAL POWER CORD • NATIONAL CHARACTER SET OPTION
VT125	80 X 24 132 X 10 132 X 24 WITH AVO OPTION	<ul style="list-style-type: none"> • NO LOCAL ECHO • FULL-DUPLEX 	OPTIONS <ul style="list-style-type: none"> • AVO 	YES	STD BIT MAP	STD ⁴	<ul style="list-style-type: none"> • NATIONAL POWER CORD • NATIONAL CHARACTER SET OPTION • EUROPEAN MODEM CONTROLS

NOTES:

1. ADVANCED VIDEO OPTION PROVIDES CHARACTER HIGHLIGHTS (BOLD, BLINK, UNDERLINE, REVERSE), ADDITIONAL 10 LINES WITH 132 COLUMN DISPLAY, HOOKS FOR EUROPEAN CHARACTER SETS.
2. ALL PRODUCTS HAVE "LINE DRAWING" CHARACTERS AS STANDARD.
3. AS AN OPTION, THE PRINTER PORT ALSO ADDS LOCAL ECHO, LINE INSERT/DELETE, AND CHARACTER INSERT/DELETE TO THE VT100.
4. SCREEN COPY IN GRAPHIC MODE ONLY.

MR 9560

Figure 4-2 VT100 Series of Terminals, Comparison Chart

4.3 LA120-DA/DECwriter III

The LA120-DA freestanding printing terminal, shown in Figure 4-3, features a contoured, typewriter-like keyboard and a 180 char/s dot matrix printer that prints bidirectionally. It uses a nonvolatile memory that stores features selected in set-up mode. The LA120-RA is a version of the DECwriter III that has no keyboard (it is a receive-only terminal). A comparison of the printing characteristics of the LA120 DECwriter III with those of the LA100 terminals is shown in Figure 4-4. You can obtain additional information on the LA120 DECwriter III from the *LA120 User's Guide* (EK-LA120-UG).

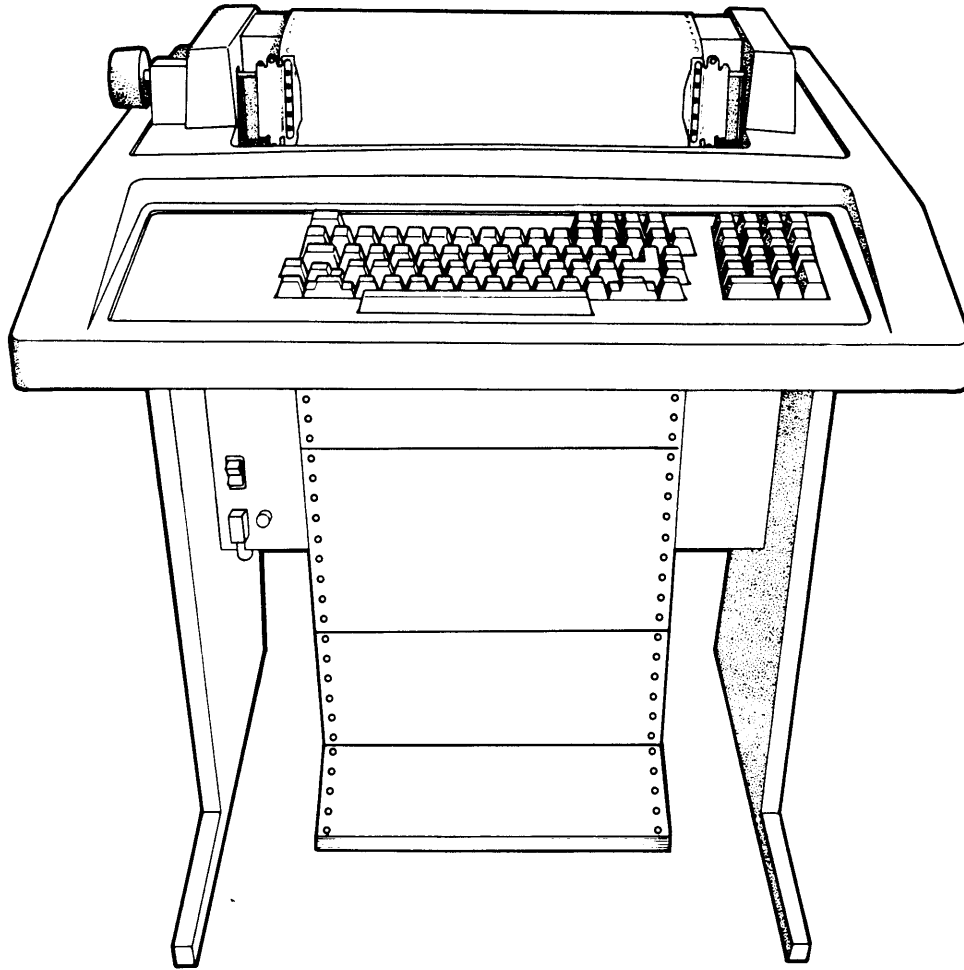

MR-3734

Figure 4-3 LA120-DA DECwriter III

MODEL	PRINTING SPEED CHAR/S	NUMBER OF COLUMNS	PRINTING CHARACTERS	PRINTING TYPE	FONT SIZES	BI-DIRECTIONAL PRINTING
LA120	180	132*	96	7 X 7 DOT MATRIX	8	YES
LA100	240 80 30	217	96	9 X 7 DOT MATRIX	5	YES

* NUMBER OF COLUMNS VARIES WITH FONT SIZE.

MR 9561

Figure 4-4 Hardcopy Terminals, Comparison Chart

4.4 LA100 LETTERWRITER 100

The LA100 Letterwriter 100 is a desktop, microprocessor-controlled hard-copy terminal that features a contoured, typewriter-like keyboard. It is a highly versatile, multimode terminal designed for use with video workstations and small business systems. The LA100 Letterwriter 100 is available in a receive-only version called the LA100 Letterprinter 100. Both LA100 versions are 240 char/s dot matrix printers that can produce hard-copy graphics. The LA100 Letterwriter 100 is shown in Figure 4-5. Figure 4-4 compares the printing characteristics of the LA100 terminals with those of the LA120 DECwriter III.

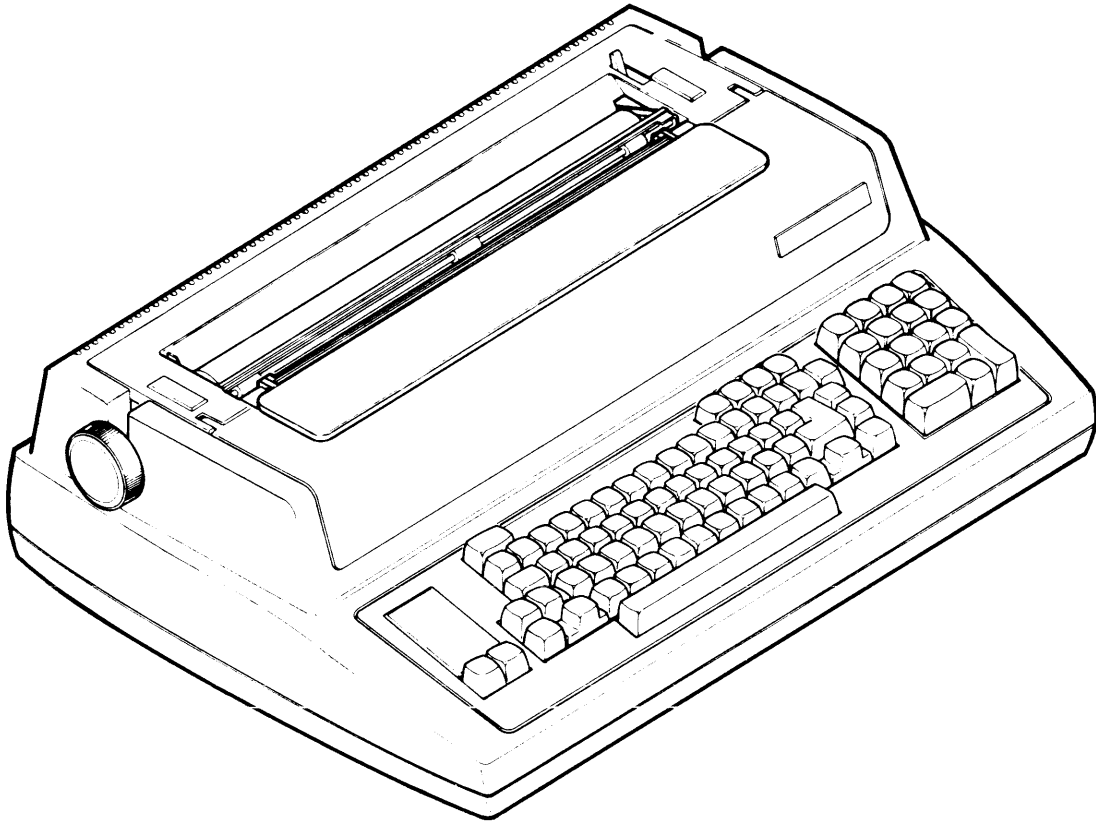

MR-9562

Figure 4-5 LA100 Letterwriter 100

CHAPTER 5

SYSTEM REQUIREMENTS AND MAINTENANCE

5.1 INTRODUCTION

The MICRO/PDP-11 system is designed for use in business and light industrial settings. However, the characteristics of the system's immediate environment should fall within the limits defined in this chapter.

5.2 ENVIRONMENT

Environment is an important consideration in the installation of any computer system, but it is particularly crucial for the proper operation of a system with diskette drives. Excess humidity and mechanical shock are especially harmful. The specifications listed in Table 5-1 should be considered when selecting an environment for the MICRO/PDP-11 system. Table 5-2 lists the power requirements of the MICRO/PDP-11 system.

Table 5-1 MICRO/PDP-11 System Environmental Specifications

Conditions	Specifications
Altitude (operating)	2400 m (8000 ft) maximum
Altitude (nonoperating)	12000 m (40000 ft) maximum
Temperature (operating)	15° C to 32° C (59° F to 90° F) nominal; reduce temperature 1.8° C/1000 m (1° F/1000 ft) above sea level
Temperature (storage)	-40° C to 60° C (-40° F to 151° F)
Temperature (maximum wet bulb)	25° C (77° F)
Temperature change rate	2° C (36° F) per hour
Dew point	2° C (36° F) minimum
Relative humidity (operating)	20% to 80% (noncondensing)
Relative humidity (nonoperating)	10% to 95% (noncondensing)

Table 5-2 MICRO/PDP-11 System Power Requirements

AC Input	Specifications*	
Line voltage	120 V	240 V
Power source phasing	Single	Single
Frequency	60 Hz	50 Hz
Voltage tolerance	88-128 VRMS	176-256 VRMS
Line frequency tolerance	47-63 Hz	47-63 Hz
Running current (maximum)	4.2 A	2.75 A
Power consumption (maximum)	320 W	320 W
Universal power supply	Switchable for ac input voltage	

*Depends on the position of the voltage selector switch.

5.3 SYSTEM TESTS AND ERROR DETECTION

When the system detects a hardware error, the program currently running determines the type of indication given. Some errors cause the system to halt any type of program, while other errors must be detected by using the appropriate diagnostic programs. An error message may be a single number or several words, depending on the program and the type of error. Such messages help in the diagnosis of hardware failures.

When a program halts, you can use hardware-implemented routines to simulate the conditions under which the error occurred. You can also halt the program if the system does not do so automatically. In addition, you can modify the maintenance programs to perform specific checks, or you can chain groups of programs together to check larger functional areas.

5.3.1 Bootstrap/Diagnostic ROM Programs

Read-only memories (ROMs) located on the KDF11-BE module (which will be from here on referred to as the M8189 module) contain the bootstrap/diagnostic programs. CZK DFA0 KDF11B-BE BOOT ROM listing (part number AC-T577A-MC) or microfiche listing (part number AH-T578A-MC) contain complete listings of the programs included in the ROMs. These programs are switch-selectable. (Refer to Chapter 2.) To use these internal diagnostics, switch S1 (E102) on the M8189 module must be positioned as defined in Table 2-2.

Each time the MICRO/PDP-11 system is switched on or the restart switch is pressed (when the halt switch/indicator is off), the programs selected by the switches are executed. The system has successfully completed running these hardware-supplied diagnostics when the following message is displayed on the terminal.

```

KDF11B-BE ROM V0.8

  128KW MEMORY
  9 STEP MEMORY TEST
  STEP 1 2 3 4 5 6 7 8 9
  TOTAL MEMORY ERRORS = 0
  CLOCK ENABLED
    
```

The system then attempts to find a bootable MSCP medium on the system. If neither of the diskette drives nor the fixed disk drive is bootable at this time, a message similar to the following is displayed.

```
ERROR UNIT DU0  
ERR 16 NOT BOOTABLE
```

```
ERROR UNIT DU2  
ERR NOT BOOTABLE
```

```
ERROR UNIT DU1  
ERR 16 NOT BOOTABLE  
WISH TO REBOOT [Y,(N)]?
```

Other types of errors may be reported by the boot/diagnostic ROM, as shown in Table 5-3.

Table 5-3 Boot/Diagnostic ROM Error Types

Error Number	Definition
01	No memory
02	Fatal memory fault
03	Memory fault
04	MMU abort
05	Trap 4
06	Trap 10
07	Trap 14
08	Trap 20
09	Power fail
10	Trap 30
11	Trap 34
12	Nonexistent controller
13	Drive not ready
14	Drive error
15	Controller error
16	Not bootable
17	No disk
18	No tape
19	Nonexistent unit
20	ROM E126 bad
21	ROM E127 bad
22	No forced parity
23	No parity interrupt

If you choose not to reboot (by responding to the reboot question by typing **N** and pressing the **Return** key), the system displays a list of commands.

If you are using an ANSI console terminal, the following message is displayed.

128 KW MEMORY KDF11B-BE ROM V06X CLOCK ENABLED

MAIN MENU

BOOT
HELP
MAP
DIAGNOSE

Press RETURN to select BOOT

Use cursor controls "UP ARROW" or "DOWN ARROW" to select function

Use CTRL/W to reset menu

If you are using a non-ANSI terminal and do not wish to reboot, the following message is displayed.

Type ? for HELP
Enter one of [Boot, Diagnose, Help, List, Map]:

The functions performed by these commands (on both ANSI and non-ANSI terminals) are listed below.

Boot – Loads a program from the selected medium.

Help – Prints the list of possible commands and their functions.

Map – Executes the system mapping routine. This routine displays the following information on the console terminal.

1. The CPU options installed on the KDF11-BE module.
 - a. Extended instruction set (EIS) that is standard on the MICRO/PDP-11 system
 - b. Commercial instruction set (CIS)
 - c. Floating-point instruction set (FIS).

CIS and FIS are microcode options (MOS chips) that may be added to the M8189 module.
2. The memory starting and ending addresses found on the system. The process of displaying this information takes about two minutes and can be aborted by entering a CTRL/C.
3. The range of I/O page addresses found on the system. The type of device associated with each address is not identified, however.

Diagnose – Executes an extended memory test. This test is more comprehensive than the one that takes place automatically whenever the system is powered up. This test, therefore, takes longer to be performed (approximately 25 minutes for 128 K words of memory).

List (on non-ANSI terminals) – Prints a list of bootable devices present on the system. (This function is part of the bootstrap command on ANSI terminals.)

If one of the hardware-supplied diagnostic programs fails to function properly, the console terminal may display an error message that follows the following format.

nnnnnn
@

The nnnnnn defines the address at which the error occurred. The @ sign indicates that the system has halted and control has passed from the program to console emulator mode, in which the system responds to on-line debugging technique (ODT) commands. (Appendix B provides a list of basic ODT commands that may be used at this time.) You can use the nnnnnn address displayed on the console terminal to isolate the failure. Use the CZK DFA0 KDF11B-BE BOOT ROM listing (part number AC-T577A-MC) or microfiche listing (part number AH-T578A-MC) to find the location of the error halt in the program and determine the cause. The boot/diagnostic ROM listing also provides scope loop routines that may be used for troubleshooting purposes.

If the nnnnnn address does not appear, check the diagnostic LEDs on the M8189 module to determine the failure. Refer to Figure 5-1 and Table 5-4 for the location and definition of the diagnostic LEDs.

NOTE

The display LED pattern indicates that the corresponding test is in progress or has failed. Some tests retry (switch S1 set to DECnet boot), while others halt the CPU (switch S1 set to CPU test, memory test, or non-DECnet boot).

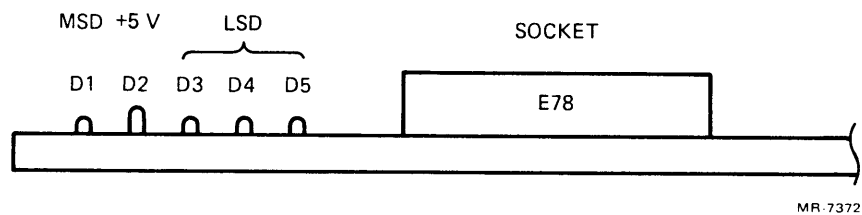

Figure 5-1 Diagnostic LED Locations

Table 5-4 Diagnostic LED Error Displays

Display LED (octal)	MSD D1 Bit 3	LSD D3 Bit 2	D4 Bit 1	D5 Bit 0	Type of Error
00	Off	Off	Off	Off	Boot/diagnostic ROM not executing.
01	Off	Off	Off	On	CPU error.
02	Off	Off	On	Off	Memory error.
03	Off	Off	On	On	Waiting for console terminal XMIT ready flag.
04	Off	On	Off	Off	Waiting for console terminal receiver done flag.
05	Off	On	Off	On	Boot device status error.
06	Off	On	On	Off	Invalid bootstrap block.
07	Off	On	On	On	DECnet waiting for response from host.
10	On	Off	Off	Off	DECnet waiting for message completion.
11	On	Off	Off	On	DECnet processing received message.
12	On	Off	On	Off	MMU error.
13	On	Off	On	On	Error in first 28 K words of memory (fatal error).
14	On	On	Off	Off	Scope loop.*
15	On	On	Off	On	Extended memory test error.
16	On	On	On	Off	MAP function error.
17	On	On	On	On	System hung, halt switch on, or switch S1 not configured properly.

* Refers to a section of the ROM program accessed by Field Service in order to loop through the ROM program for troubleshooting purposes. Refer to CZKDFA0 KDF11B-BE BOOT ROM listing (part number AC-T577A-MC) or microfiche listing (part number AH-T578A-MC).

5.3.2 User Test Diskette

When the user test diskette is booted on the system, the following message is displayed.

BOOTING FROM DU1

Loading USER Tests: V2.0 this will take about 5 seconds.
Please wait

The unit number specified in the message depends on which drive the user test diskette was booted from. The version number of the user test diskette may differ from the one shown above (V2.0). When the program is successfully loaded, the following message is displayed.

**** MAIN COMMAND MENU **** V2.0 ****

What would you like?

T - TEST your SYSTEM to see if it's O.K.

I - INFORMATION on all COMMANDS.

D - DESCRIPTION of your SYSTEM.

H - HELP

? - HELP

Please type appropriate letter followed by "RETURN" key:

In order to test the system, type **T** and press the **Return** key. The system's user test monitor then automatically runs the appropriate DEC/X11 run-time exerciser present on the user test diskette, and supplies the following directions.

Directions:

Install a blank diskette in REMOVABLE DISK DRIVE 2. Make sure that orange arrow on the diskette aligns with the orange bar on the drive.

When the above has been completed proceed by typing the "RETURN" key.

Type "M" to return to MAIN COMMAND MENU or "RETURN" to proceed:

If you press the **Return** key, the following message is displayed.

The System Test is now running.

This test will run for approximately 10 minutes. When testing has been completed, results of the test will appear on this terminal. DOTS will be displayed in a repeating pattern to show testing in progress.

.....

If the test is successfully completed, the following message is displayed.

Testing of this system is now complete.
No errors have been detected.
The system is O.K.

You can now continue by installing new software or running existing software. To install new software, refer to installation instructions in your software box.

You are then directed to remove the user test diskette if testing of the system is complete. You may choose to retest the system by keeping the diskette installed and returning to the main command menu.

However, if an error has occurred, the following message is displayed.

An error was detected by the System Test.

An audible signal will be heard from the terminal when the cause has been found.

The user test now automatically runs the individual XXDP+ diagnostic programs for each of the FRUs in the system. The results of each test are reported one at a time as each test is completed. The following is displayed in the event of a memory failure.

	APPROXIMATE MINS TO TEST:	Results
Testing Processor.....	.1.....	.OK
Testing Memory.....	.1.....	.ERROR

Error detected in Testing Memory

Check Owner's Manual troubleshooting chapter on how to proceed or please call your Field Service representative.

What would you like ?

- R - RETRY The failing test.
- C - CONTINUE with test sequence.
- M- Return to the MAIN COMMAND MENU.

Please type appropriate letter followed by "RETURN" key:

If you choose to continue testing, other failing FRUs will be reported.

The user test diskette makes use of the XXDP+ software system to isolate a failing FRU on the MICRO/PDP-11 system. If it is necessary to use XXDP+ programs to further test or troubleshoot the system, install the Field Service test diskettes. Use of the Field Service test diskettes as troubleshooting tools is discussed in Paragraphs 5.5 and 5.6.

5.4 ON-LINE DEBUGGING TECHNIQUE (ODT)

The on-line debugging technique (ODT) is the most basic way you can communicate with the system. ODT consists of a group of commands and routines for finding error conditions and for simple communication with the system.

The hardware-implemented ODT commands are a subset of the commands in a larger software-implemented ODT program. The hardware ODT program, which resides on the M8189 module, serves primarily for hardware-oriented diagnosis of problems. The system's responses to ODT commands help trace events occurring in the system.

CAUTION

The hardware ODT can modify programs; therefore, remove master diskettes before using ODT.

The ODT functions only when the system is in console emulator mode. This mode of operation replaces the use of switches and indicators on a console panel in communicating directly with the system. You can type commands on the keyboard, and the system displays responses on the console terminal instead of lighting indicators on a computer console. The system enters console emulator mode when any of the following occurs.

1. The program executes a halt instruction.
2. The system detects an error.
3. You press the halt switch on the control panel.

When the system halts the program and enters console emulator mode, it displays the following on the console terminal.

```
nnnnnn
@
```

The number nnnnnn is the octal location of the next instruction to be executed, and the @ is the ODT prompt character. At this point you may examine or modify the contents of the system's registers and memory by entering ODT commands. A table of basic ODT commands is provided in Appendix B. The use of ODT commands is explained in the *Microcomputers and Memories Handbook* (EB-18451-20).

5.5 TROUBLESHOOTING WITH THE DEC/X11 RUN-TIME EXERCISER

The Field Service test diskettes provided in the master kit portion of the MICRO/PDP-11 system test kit supply you, as a technician, with a means of building a run-time exerciser and using it to troubleshoot the system. The exerciser consists of a group of program modules. Each module tests a specific component of the MICRO/PDP-11 system.

When the run-time exerciser detects an error, it displays an error message that describes the circumstances of the failure. In analyzing the message, first determine what system component was involved in the error. Then, either run the appropriate XXDP+ diagnostic program or analyze the error message further. Next, look up the error call in the listing for the specific program module to see what operation was in progress when the error occurred. Finally, examine the parameters of the failure (program counter, processor status word, stack pointer, etc.).

You can modify program modules to halt on different errors, provide different status displays, and run alone or with selected other programs. You can use ODT to examine system registers and memory locations. Such detailed analysis requires extensive knowledge of DEC/X11 commands and the computer hardware. Chapters 5 through 9 of the *DEC/X11 User's Manual* (AC-F053-MC), and the *DEC/X11 Cross-Reference Manual* (AC-F055C-MC) explain commands, errors, and techniques. The *Microcomputers Interfaces Handbook* (EB-20175-20) and *Microcomputers and Memories Handbook* (EB-18451-20) describe the system's hardware, peripherals, and memory options. This manual discusses fault isolation to the system component level only.

5.5.1 Error Messages

The run-time exerciser provides displays of three basic types of errors: system errors, data errors, and status errors.

5.5.1.1 System Error Message – The DEC/X11 run-time exerciser displays a system error message when it detects one of the following.

1. A bus error trap (to location 4)
2. A reserved instruction trap (to location 10)
3. A queue overflow

A system error message can be recognized by the mnemonic SYS ERR. If a system error occurs, run the program modules individually. If all modules pass when they are run alone, run them in groups until the failure returns. Refer to Paragraph 5.5.2 for instructions on selecting individual program modules.

5.5.1.2 Data Error Message – The program modules display data errors in the following format.

```
RQAA0 PC XXXXXX APC YYYYYY PASS# NNNNN. ERR# NNNNN. DATA ERROR
CSRA AAAAAA S/B BBBB WAS WWWWW WRADR DDDDD RDADR
EEEEEE
```

where:

RQAA0 is the name of the failing module (listed as XRQAA0.OBJ in the directory).

PC XXXXXX is the physical address of the program call that causes the message (program counter).

APC YYYYYY is the assembled program count of the program call.

PASS# NNNNN. is the pass number (decimal) during which the error occurred.

ERR# NNNNN. is the error count (decimal) for the current run.

CSRA AAAAAA is the address of the control and status register of the failing device.

S/B BBBB is the expected data (S/B, or “should be,” data).

WAS WWWWW is the bad data.

WRADR DDDDD is the address of the expected data (S/B, or “should be,” data).

RDADR EEEEE is the address of the bad data.

A data error message is recognized as such because its first line ends with the words DATA ERROR. The first line starts with the name of the program test module, which can be referenced in the module abstracts. You can rerun the DEC/X11 modules individually, or run the appropriate XXDP+ program (refer to Table 5-5). If you need to examine the DEC/X11 error message further, find the assembled program count (APC) value in the program listing. The location displayed for the APC contains the program call that caused the error message.

Table 5-5 XXDP+ Diagnostic Programs

XXDP+ Program Name	Title
JKDB??.BIC	F-11 basic instruction test
JKDA??.BIC	KDF-11 MMU test
JKL5??.BIC	KDF-11B CPU cluster test
VM8AF?.BIN*	BOOT/ROM test
VMSA??.BIC	Q-Bus 22-bit address memory test
VDZA??.BIC	DZV-11 test; part one
VDZB??.BIC	DZV-11 test; part two
VDZC??.BIC	DZV-11 loopback test
ZRQA??.BIN	RD/RX performance exerciser
ZRQB??.BIN	RD-51 formatter program

*Revision of VM8A?? must be version F0 or later.

5.5.1.3 Status Error Message – This message is in the same general format as the data error message. It can be recognized as a status error message by the absence of the terms **SYS ERR** or **DATA ERROR** in its first line. This message does not contain the **S/B** (“should be”) or **WAS** messages, but instead, includes a **STATC** value. This value is the contents of the status register of the failing device. Like a data error, a status error can be traced to a listing by looking up the location given for the **APC**.

5.5.2 Selecting and Deselecting Program Modules

When troubleshooting the **MICRO/PDP-11** system, you may find it useful to delete a failing program module or delete all modules except the one or two that are failing. You can accomplish this by using the select and deselect commands. You can deselect program modules one at a time, or deselect all modules and then select only those desired. The commands function as follows.

Command	Function
.SEL<CR>	Selects all modules for execution.
.SEL RQAA0<CR>	Selects only the RQAA0 program module. The program name must be typed as it appears in the listing.
.DES<CR>	Deselects all modules.
.DES RQAA0<CR>	Deselects only the RQAA0 module.

NOTE

The select and deselect commands operate only within the system exerciser program. They cannot be executed without first starting the exerciser.

You can obtain the status of a module (selected or deselected) by using the map command. This command instructs the monitor program to display a list of the resident modules with their starting addresses and status. For example:

```
.MAP<CR>

CPAFO AT 017752 STAT 040020
CPBGO AT 021502 STAT 040020
RQAA0 AT 023242 STAT 150000
```

The second most significant octal digit of the STAT (status) message indicates whether or not a module is selected. If the number is a 0, 1, 2, or 3, the module is deselected; if it is a 4, 5, 6, or 7, the module is selected. Bit definitions for the complete number are given in Chapter 5 of the *DEC/X11 User's Manual* (AC-F053-MC) and also in the *DEC/X11 Cross-Reference Manual* (AC-F055C-MC).

5.5.3 Expanding the Run-Time Exerciser

Each system has a run-time exerciser designed for that system's configuration. If you expand the system, you must rebuild the exerciser in order to test the added components. You must rebuild the exerciser rather than just add to it because it is an *interactive* system of programs. Rebuilding involves selecting the program modules appropriate to the new hardware and including them with the existing program modules in a new exerciser. Refer to the *DEC/X11 User's Manual* (AC-F053-MC) and *DEC/X11 Cross-Reference Manual* (AC-F055C-MC) for detailed explanations of the steps involved in rebuilding and the possible error messages that may appear during the process.

5.6 TROUBLESHOOTING WITH THE XXDP+ DIAGNOSTIC PROGRAMS

The Field Service test diskettes provided in the master kit portion of the MICRO/PDP-11 system test kit supply you, as the technician, with a means of troubleshooting the MICRO/PDP-11 system through the use of XXDP+ diagnostic programs. These diskettes include the XXDP+ diagnostic programs that are recommended for testing the typical configuration of the MICRO/PDP-11 system. Some of these programs are listed in Table 5-5.

Other XXDP+ diagnostic programs are also provided on the diskettes as a means of testing options that have been added to the MICRO/PDP-11 system.

The XXDP+ diagnostic software system helps to isolate failures by testing the function of the selected field-replaceable unit (FRU). The result of a test is reported on a pass/fail basis.

These diagnostic programs can be modified to perform specific functions within the general functional areas they test. Modification of the XXDP+ programs requires careful study of the program listings and the *XXDP+/SUPR User's Manual* (AC-F348A-MC). This user's manual describes the commands available under the various XXDP+ utility programs, listing specific program modifications and procedures.

The following paragraphs describe some of the more common operations.

5.6.1 Error Messages

The XXDP+ diagnostic programs do not use a universal format for error messages. The large number of parameters tested makes a variety of formats necessary. Most formats display several octal words, giving the parameters at the time of the error and a mnemonic indicating what occurred. Since the meanings of these mnemonics are usually program-specific, they must be referenced in the tables or error directories of individual program listings.

5.6.2 Restarting Programs

Diagnostic programs can be configured to run continuously, halt at the end of a pass, and/or halt (or loop) on selected errors. You can halt a program by pressing the halt switch. You can then enter ODT commands or restart the diagnostic program by typing the restart address given in the program listing. For example:

```
@200G
```

If the diagnostic program has not overwritten the memory locations of the XXDP+ monitor program, you can restart the monitor by typing the restart address that was displayed in the monitor heading when the diskette was booted. If the diagnostic program did overwrite the memory locations, the diskette must be rebooted to return to the XXDP+ monitor.

5.6.3 Modifying a Diagnostic Program

Diagnostic programs can be modified to perform specialized diagnostic functions. The individual program listings explain what to modify for each purpose. The modification process requires the use of the ODT commands to change the contents of certain locations. For example, assume the memory exerciser program must be changed to perform a loop on error. The program listing directs you to change software switch register 176 to 1000. To do so, use the following steps.

1. Load the program with the L command instead of the R command.

```
.L VMSA??<CR>
```

The system loads the program into memory and displays the . (period) prompt character. The program is not executed at this time.

2. Press the halt switch on the control panel. This places the system in console emulator mode and gives control to the ODT program. The system responds by displaying the @ prompt character.
3. Open location 176 by typing **176** and pressing the / (slash) key. The system responds by displaying the present contents of that location.

```
@176/000000
```

4. After the zeros displayed by the system, type the number specified by the program listing.

```
@176/000000 1000<CR>  
@
```

5. Verify that the change has been made by typing **176/** again and examining what is displayed. If the contents are correct, press the **Return** key.

```
@176/001000<CR>  
@
```

6. Start the program at location 200 with the ODT go command.

```
@200G
```

7. The system displays the program name and executes the program. When testing is complete, the system displays END PASS and starts another pass.
8. To terminate the program, press the halt switch. This returns control to the ODT program. To return to the XXDP+ monitor program, press the halt switch again (so that it goes back to its up position), and press the **Restart** key.

Modifying the program by this method affects only the system's memory; it does not change the program on the diskette. Therefore, it is not necessary to restore the contents of the location after the program is completed.

The basic ODT commands are listed in Appendix B of this manual. Additional information pertaining to ODT is available in the *Microcomputers and Memories Handbook* (EB-18451-20).

5.7 TROUBLESHOOTING PROCEDURES

In order to isolate a failing FRU in the MICRO/PDP-11 system, follow the recommended procedure described in Figure 5-2 (Sheets 1 and 2).

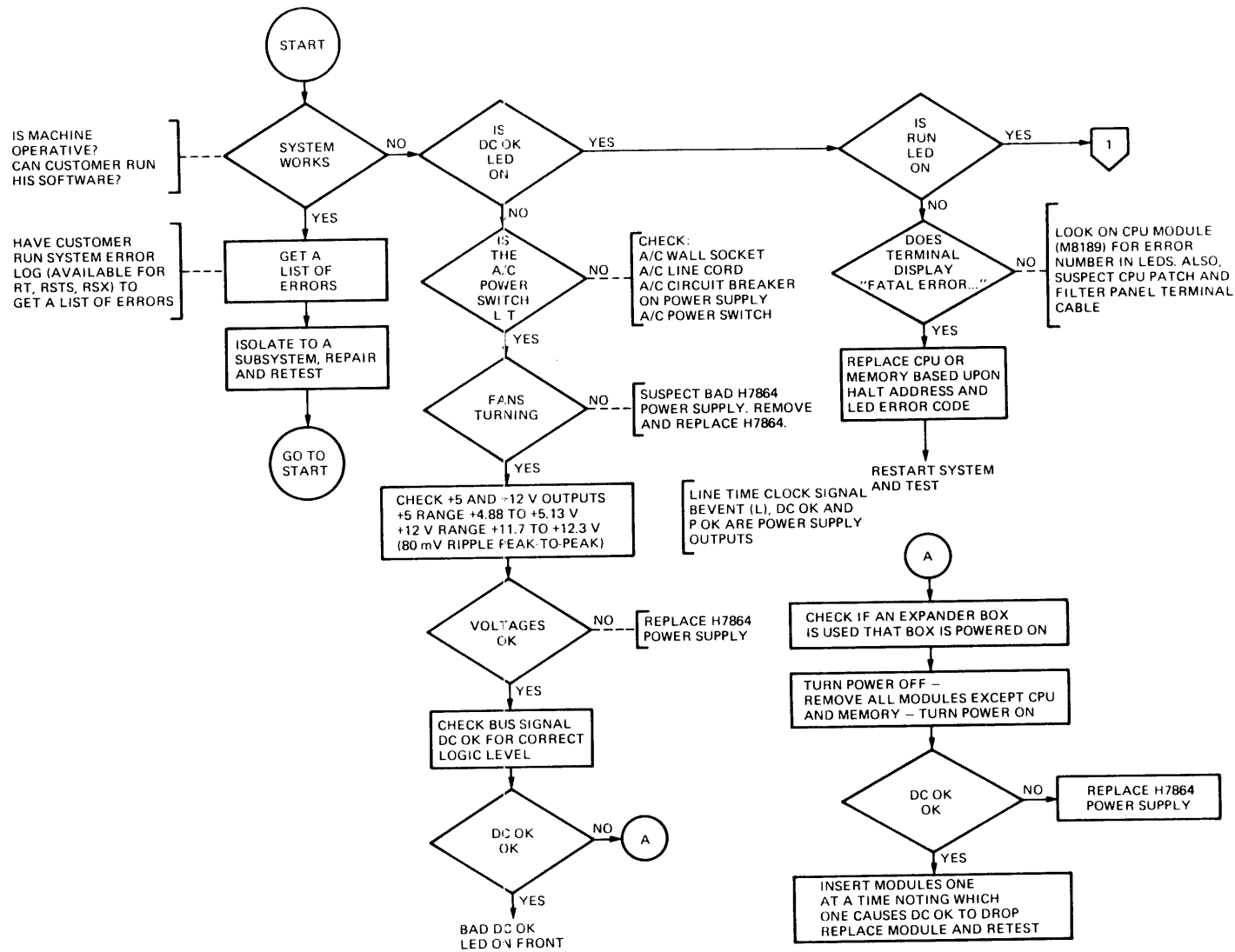

Figure 5-2 Troubleshooting Flowchart (Sheet 1 of 2)

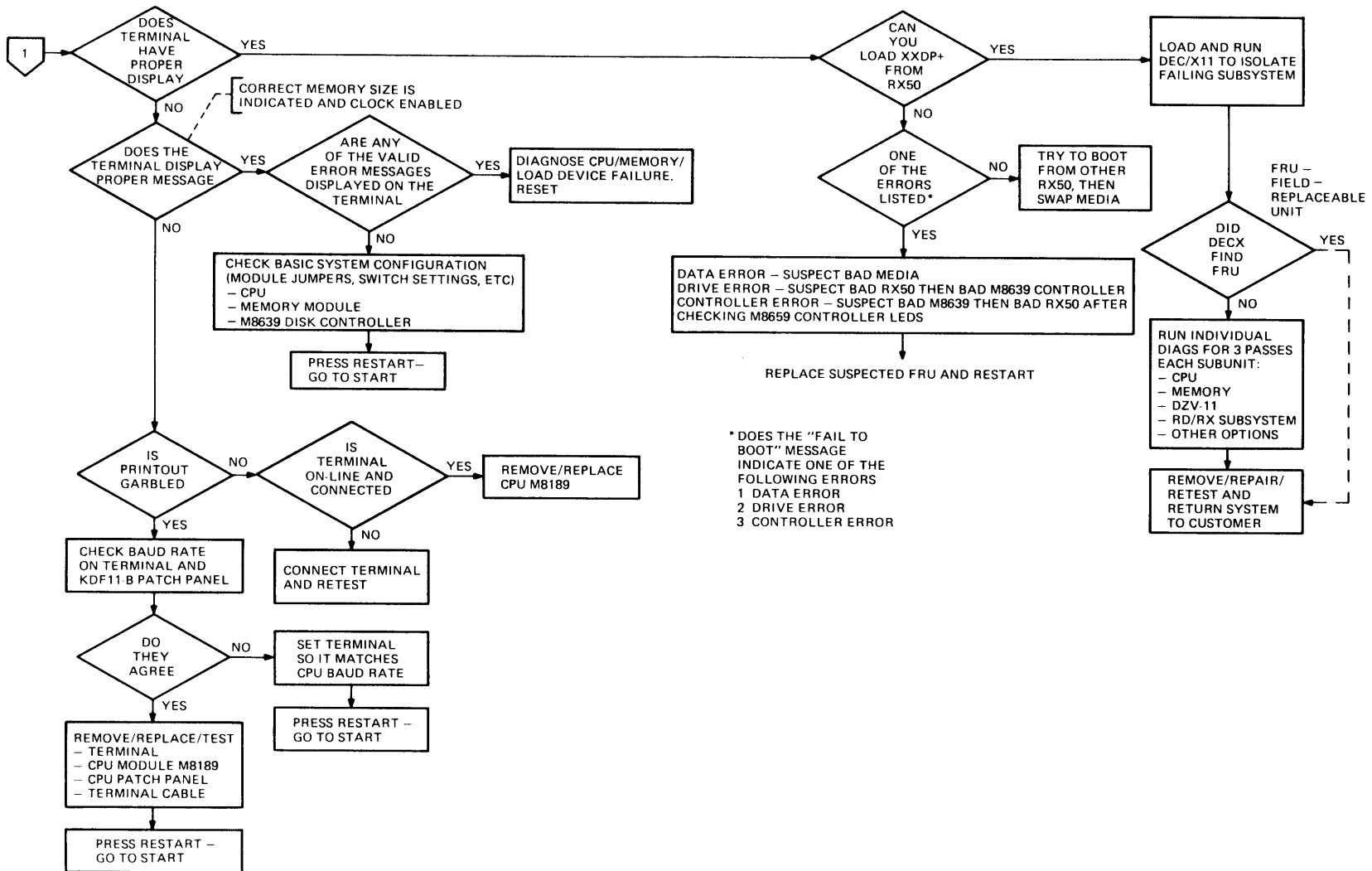

Figure 5-2 Troubleshooting Flowchart (Sheet 2 of 2)

5.8 CORRECTIVE MAINTENANCE

The location of each field-replaceable unit (FRU) in the MICRO/PDP-11 system is shown in Figure 5-3. The recommended repair procedure for each of the MICRO/PDP-11 system's FRUs is defined in Table 5-6.

NOTE

The removal and replacement procedures in the following paragraphs often refer to the front and rear plastic covers of the MICRO/PDP-11 system. Note that the rack mount package does not have a rear plastic cover.

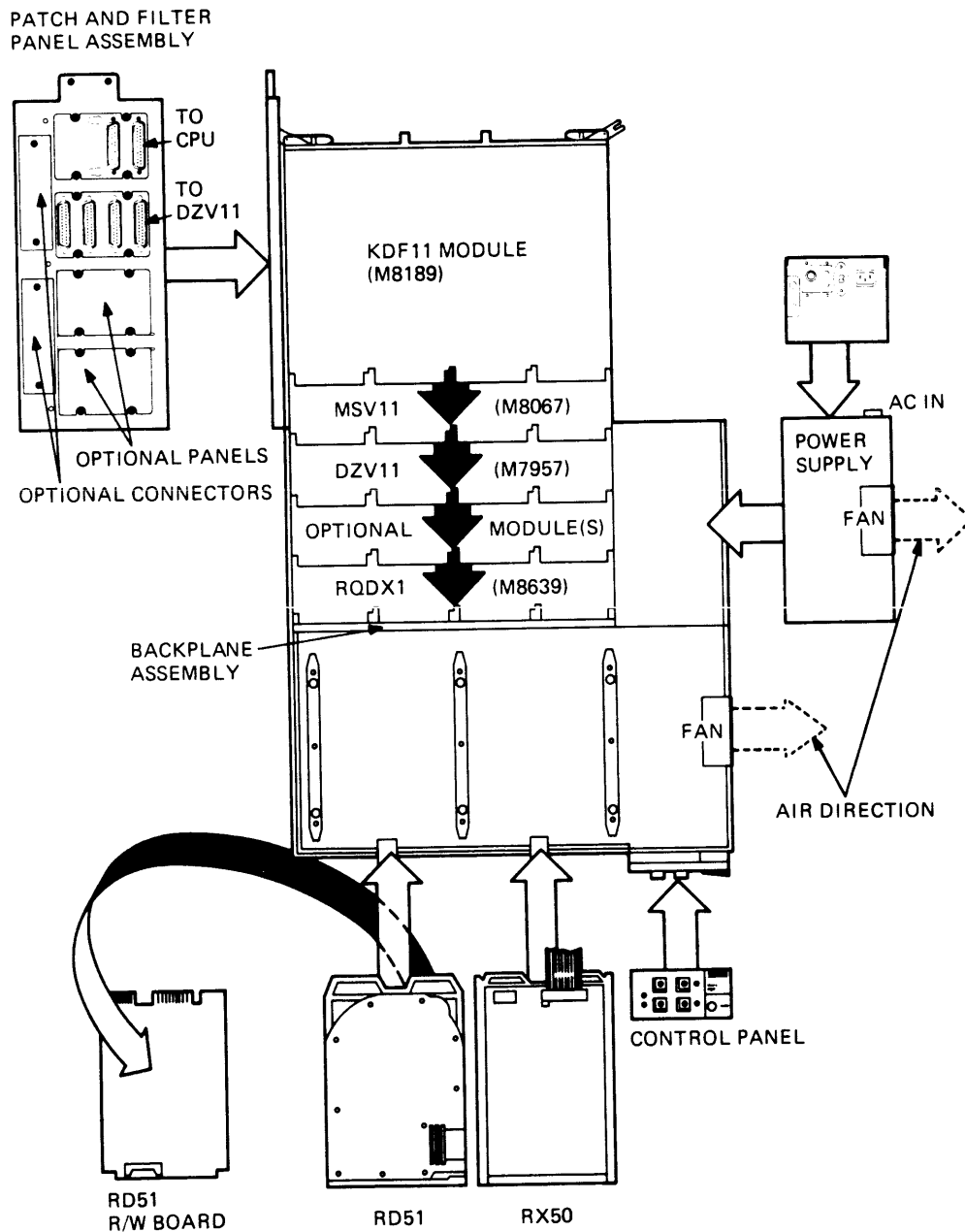

Figure 5-3 MICRO/PDP-11 System FRUs, Expanded View

MR-9542

**Table 5-6 Recommended Repair Procedures for
MICRO/PDP-11 System FRUs**

FRU	Repair Procedure	Order Part Number
KDF11-BE	Replace module. (If replaced with a KDF11-BE, the ROMs from the original module must be installed on the replacement module.)	KDF-11BE
MSV11-PK	Replace module.	M8067-KX*
DZV11-A	Replace module.	M7957
RQDX1 controller	Replace module.	M8639
RQDX1 signal distribution cable	Replace cable.	BC02D-1D
H7864 power supply	Replace unit.	30-20444-01
System unit dc fans	Replace fan.	12-17556-01
DC fan power cable	Replace cable.	70-20449-OD
Diskette drive	Replace diskette drive.	RX50-AA
RX50-AA signal cable	Replace cable.	17-00285-02
RX/RD power cable	Replace cable.	70-20435-1K
Fixed disk drive	Replace drive. You may wish to replace the read/write board first, if you have a spare.	RD51-A
RD51-A read/write printed circuit board	Replace module.	29-24665-00
DIP shunt for RD51-A read/write printed circuit board	Replace shunt.	29-24115
RD51-A signal cable (20-conductor)	Replace cable.	17-00282-00
RD51-A signal cable (34-conductor)	Replace cable.	17-00286-00

*The -KX suffix means any suffix from -KA through -KG.

**Table 5-6 Recommended Repair Procedures for
MICRO/PDP-11 System FRUs (Cont)**

FRU	Repair Procedure	Order Part Number
Control panel	Replace control panel.	54-15610
Control panel cable	Replace cable.	70-20451-1C
AC power cable (includes on/off switch)	Replace cable.	70-20434-01
Patch and filter panel assembly	Replace assembly.	70-19979-00
CPU patch and filter panel	Replace patch and filter panel.	54-15422
CPU patch and filter panel cable	Replace cable.	70-19933-1C
DZV11 patch and filter panel	Replace patch and filter panel.	54-15420
DZV11 patch and filter panel cable	Replace cable.	BC05L-01
Backplane assembly	Replace backplane assembly.	70-19986-00
Backplane dc power cable	Replace cable.	70-20450-01

*The -KX suffix means any suffix from -KA through -KG.

5.8.1 KDF11-BP Central Processing Unit Assembly Removal and Replacement Procedure

Use the following procedure to remove and replace the KDF11-BE central processing unit (M8189) module.

1. Make sure no dc power is applied to the backplane when removing or inserting the module.
2. Remove the rear plastic cover from the system unit by holding each end of the cover and pulling it off.
3. Open the patch and filter panel assembly by loosening the two (captive) screws on the assembly. Swing open the assembly to allow access to the modules installed in the backplane.
4. Disconnect the cable connecting the M8189 module to the CPU patch and filter panel at the M8189 module end. Remove the M8189 module from the chassis.
5. Make sure the configuration of jumpers and switches on the replacement module is as listed in Tables 2-1 and 2-2. (If the replacement module is a KDF11-BA, it will not come with the correct switch/jumper settings.)

6. If the replacement module is a KDF11-BA (does not have ROM part numbers 23-157E4 and 23-158E4 installed), install the boot/diagnostic ROMs from the original M8189 module on the replacement module. Failure to do so will cause a failure of the module to respond as a KDF11-BE in the MICRO/PDP-11 system. If the replacement module is a KDF11-BE, the correct ROMs will be present.
7. Install the replacement module by reversing steps 2 through 4.

CPU Patch and Filter Panel Removal and Replacement Procedure

Use the following procedure to remove and replace the CPU patch and filter panel.

1. Make sure the ac power cord is unplugged.
2. Remove the rear plastic cover from the system unit by holding each end of the cover and pulling it off.
3. Disconnect the EIA cable(s) attached to the CPU patch and filter panel. Note their original positions.
4. Open the patch and filter panel assembly by loosening the two (captive) screws on the assembly and swinging the panel open.
5. Disconnect the cable connecting the M8189 module to the CPU patch and filter panel at the panel end.
6. Remove the four screws that hold the CPU patch and filter panel to the patch and filter panel assembly.
7. Install the replacement patch and filter panel by reversing steps 2 through 6.

NOTE

Make sure that the baud rate rotary switches are properly set before connecting terminal(s) to the panel. (Refer to Figure 2-2 and Table 2-4.)

5.8.2 MSV11-PK (M8067) Memory Module Removal and Replacement Procedure

Use the following procedure to remove and replace the M8067 memory module.

1. Make sure no dc power is applied to the backplane when removing or inserting the module.
2. Remove the rear plastic cover from the system unit by holding each end of the cover and pulling it off.
3. Open the patch and filter panel assembly by loosening the two (captive) screws on the assembly. Swing open the assembly to allow access to the modules installed in the backplane.
4. Remove the M8067 module from the chassis.
5. Make sure the configuration of jumpers and switches on the replacement module is as listed in Table 2-5. If an additional memory module is being installed to expand the system, refer to Tables 6-2, 6-3, and 6-4 for the jumper configuration. (Any more additional memory modules added to the system should be installed adjacent to this memory module. That is, all memory modules should be in sequential slots following the CPU module.)

6. Install the replacement module by reversing steps 2 through 4.
7. Check the memory's operation by running memory diagnostic VSMA??BIC.

5.8.3 DZV11-CP Asynchronous Multiplexer Removal and Replacement Procedure

Use the following procedure to remove and replace the DZV11-A (M7957) module.

1. Make sure no dc power is applied to the backplane when removing or inserting the module.
2. Remove the rear plastic cover from the system unit by holding each end of the cover and pulling it off.
3. Open the patch and filter panel assembly by loosening the two (captive) screws on the assembly. Swing open the assembly to allow access to the modules installed in the backplane.
4. Partially remove the M7957 module by sliding it out of the backplane. Disconnect the cable attached to the module. Remove the module from the chassis.
5. Make sure the configuration of jumpers and switches on the replacement module is as listed in Tables 2-6 and 2-7.

NOTE

If the module uses nonstandard addresses, configure the jumpers and switches on the replacement module according to those on the removed module.

6. Install the replacement module by reversing steps 2 through 4.

DZV11 Patch and Filter Panel Removal and Replacement Procedure

Use the following procedure to remove and replace the DZV11 patch and filter panel.

1. Make sure the ac power cord is unplugged.
2. Remove the rear plastic cover from the system unit by holding each end of the cover and pulling it off.
3. Disconnect the EIA cable(s) attached to the DZV11 patch and filter panel. Note their original positions.
4. Open the patch and filter panel assembly by loosening the two (captive) screws on the assembly and swinging the panel open.
5. Disconnect the cable connecting the M7957 module to the DZV11 patch and filter panel at the panel end.
6. Remove the four screws that hold the DZV11 patch and filter panel to the patch and filter panel assembly.
7. Install the replacement patch and filter panel by reversing steps 2 through 6.

NOTE

Make sure that the arrow on the DZV11 patch and filter panel points away from the 50-pin connector panels.

5.8.4 RQDX1 (M8639) Module Removal and Replacement Procedure

Use the following procedure to remove and replace the M8639 module.

1. Make sure no dc power is applied to the backplane when removing or inserting the module.
2. Remove the rear plastic cover from the system unit by holding each end of the cover and pulling it off.
3. Open the patch and filter panel assembly by loosening the two (captive) screws on the assembly. Swing open the assembly to allow access to the modules installed in the backplane.
4. Partially remove the M8639 module by sliding it out of the backplane. Disconnect the 50-conductor cable from the module. Remove the module from the chassis.
5. Make sure the configuration of jumpers and switches on the replacement module is as listed in Table 2-8.
6. Install the replacement module by reversing steps 2 through 4. The M8639 module is typically installed in the last occupied slot of the backplane. If empty slots are left between the other modules and the M8639 module, install grant cards in those empty slots to accommodate the interrupt and direct memory access structure of the backplane.

5.8.5 RD51-A Fixed Disk Drive Removal and Replacement Procedure

Use the following procedure to remove and replace the RD51-A fixed disk drive.

CAUTION

Use extreme caution when handling the RD51-A fixed disk drive. Sudden physical shocks to the drive (such as dropping it onto a hard surface) will destroy it.

1. Make sure the ac power cord is unplugged.
2. Remove the front plastic cover by holding each end of the cover and pulling it off.
3. Remove the rear plastic cover by holding each end of the cover and pulling it off.
4. Remove the front chassis retaining bracket by removing the four screws that hold it to the plastic case.

NOTE

Before sliding the chassis forward (step 5), be sure there is enough slack in the cables in the back of the unit.

5. Slide the chassis forward, as shown in Figure 5-4, until all the front top cover screws are accessible.

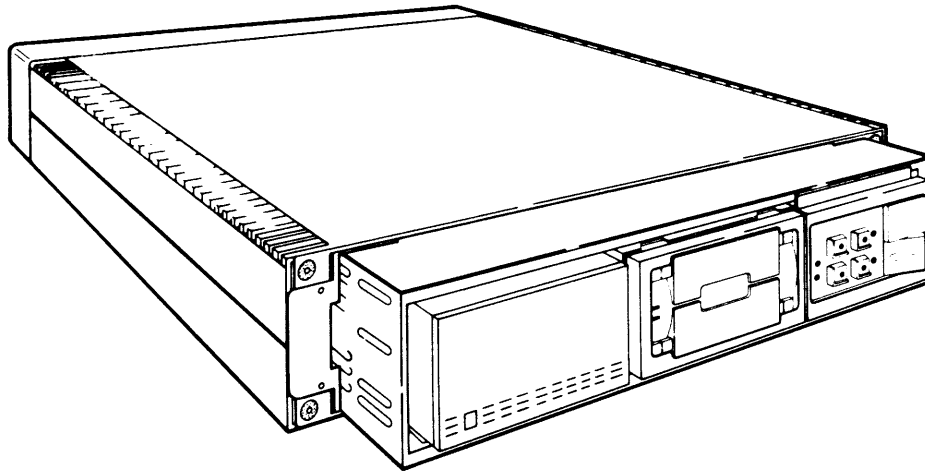

MR-10272

Figure 5-4 Front Top Cover Access

6. Remove the front top sheet metal cover from the chassis.

WARNING

When sliding the fixed disk drive forward (step 7), do not hold the drive by its front right side. Doing so will cause the head positioner flag to rotate, resulting in damage to the drive.

7. Find the release tab at the front of the fixed disk drive. Push down on the release tab and slide the drive forward about 5 cm (2 in), as shown in Figure 5-5. This provides access to the cables.

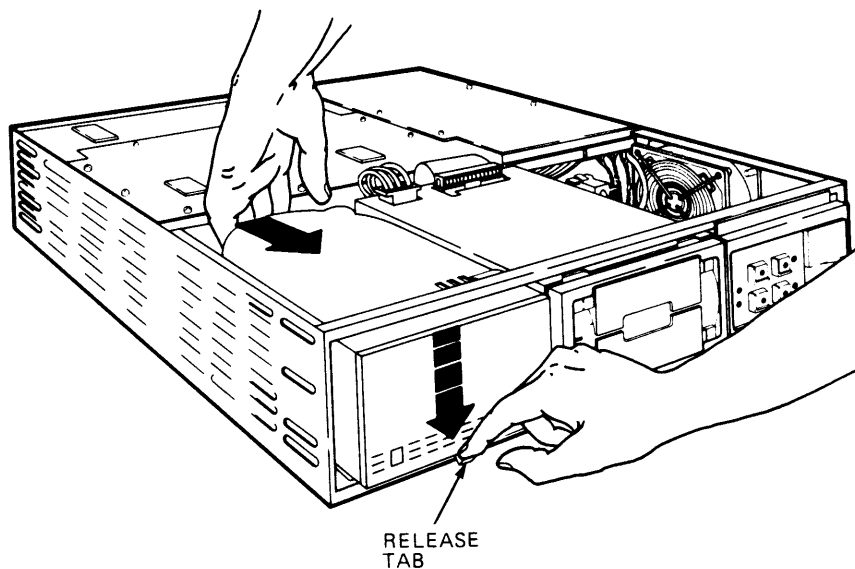

MR-9433

Figure 5-5 RD51-A Fixed Disk Drive Release Tab

8. Disconnect the two signal cables from the fixed disk drive by pulling their connectors away from the drive, as shown in Figure 5-6.

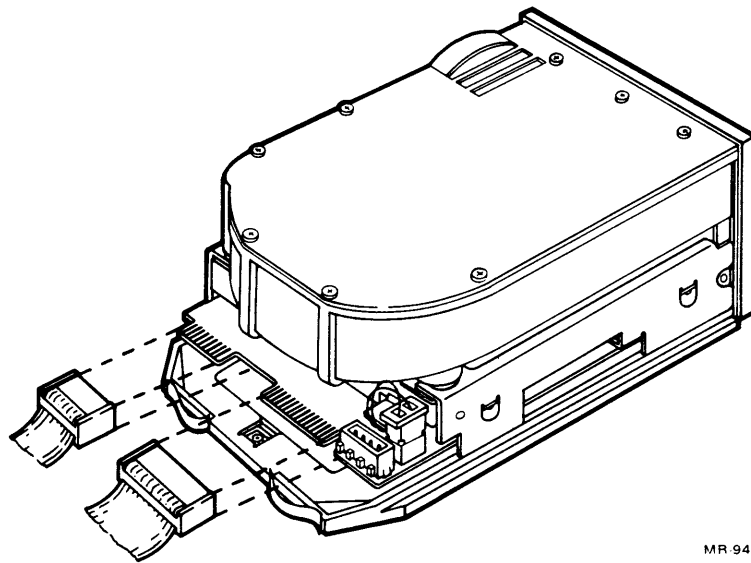

MR 9406

Figure 5-6 RD51-A Fixed Disk Drive Signal Cabling Removal

9. Disconnect the dc power cable from the rear of the fixed disk drive. The connector can be pulled straight up, as shown in Figure 5-7.

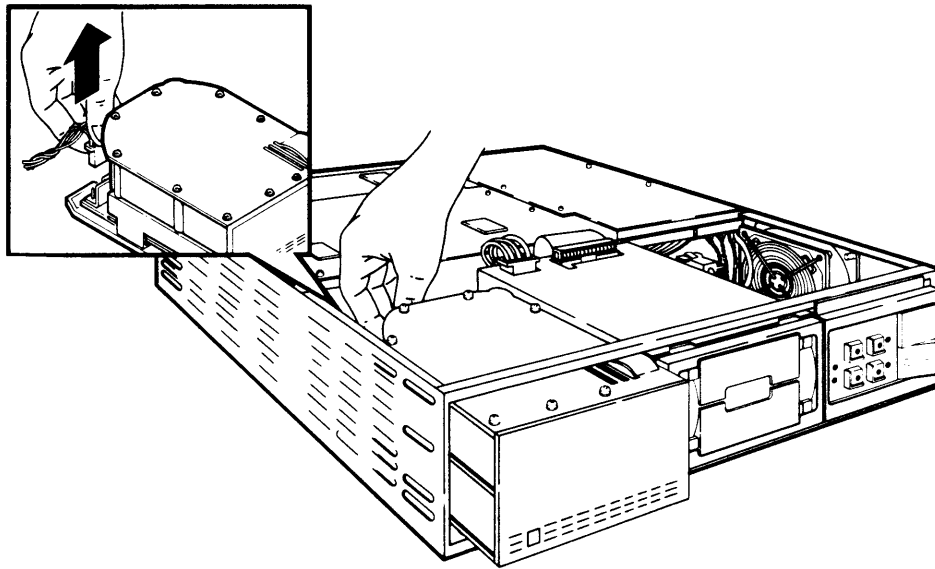

MR 9434

Figure 5-7 RD51-A Fixed Disk Drive Power Cable Removal

WARNING

When sliding the fixed disk drive out of the chassis (step 10), do not hold the drive by its front right side. Doing so will cause the head positioner flag to rotate, resulting in damage to the drive.

10. Remove the fixed disk drive by sliding it out of the chassis, as shown in Figure 5-8.

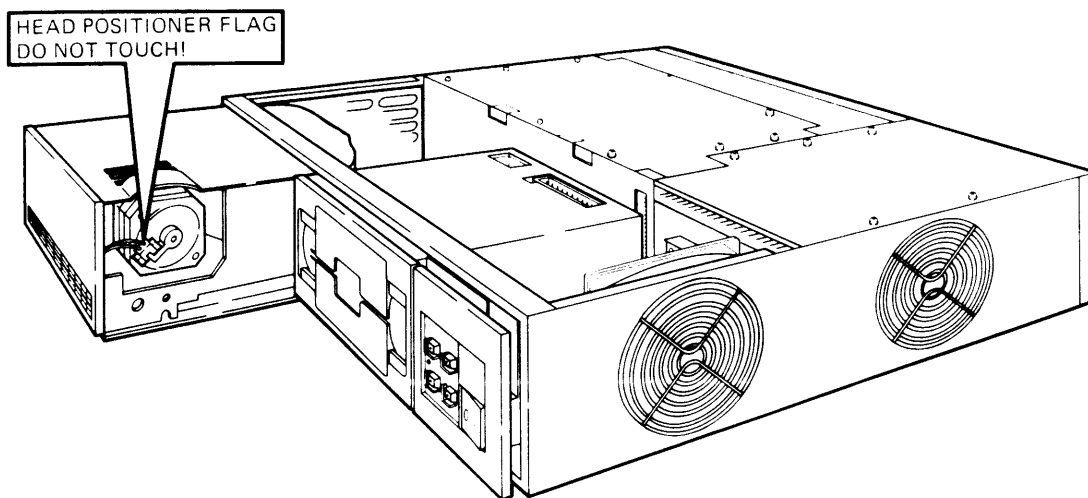

Figure 5-8 RD51-A Fixed Disk Drive Removal

MR 9976

11. Install the replacement fixed disk drive by reversing steps 2 through 10. Make sure the DIP shunt located on the read/write board of the replacement drive is properly configured (refer to Table 5-7). Refer to Paragraph 5.8.5.2 to format the replacement RD51-A fixed disk drive. You must format the replacement RD51-A fixed disk drive before it can be used.

NOTE

Use the replacement fixed disk drive's shipping carton to package the drive to be returned. If the carton is not available, one may be ordered (part number 99-90045-01).

Table 5-7 Read/Write Printed Circuit Board Jumper Configuration

Pin Numbers	Pin Connection
1 to 16	Not used*
2 to 15	In
3 to 14	In
4 to 13	In
5 to 12	Out
6 to 11	In
7 to 10	Out
8 to 9	Out

* The 14-pin DIP jumper pack is offset into a 16-pin socket toward the contact pins on the read/write printed circuit board. If the DIP shunt (jumpers) needs to be replaced, a new DIP shunt can be ordered (part number 29-24115).

5.8.5.1 RD51-A Fixed Disk Drive Read/Write Printed Circuit Board Removal and Replacement Procedure – Although the RD51-A fixed disk drive is itself a field-replaceable unit (FRU), the read/write printed circuit board may be replaced if it is the cause of a failure. This board (part number 29-24665-00) is the only part of the drive that may be replaced. Use the following procedure to remove and replace the read/write printed circuit board. Note that this procedure is recommended for Field Service use only.

1. Now that the RD51-A fixed disk drive has been removed from the mounting box, remove the four Phillips screws holding the drive skid plate to the drive. Remove the drive skid plate, as shown in Figure 5-9.

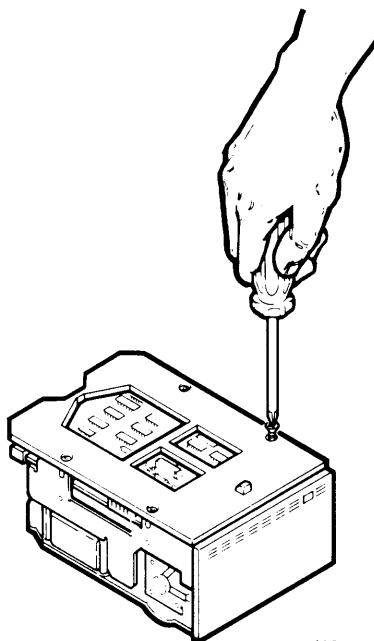

Figure 5-9 RD51-A Fixed Disk Drive Skid Plate Removal

- Using a 3/32-inch allen wrench, remove the four screws that hold the read/write printed circuit board to the fixed disk drive, as shown in Figure 5-10.

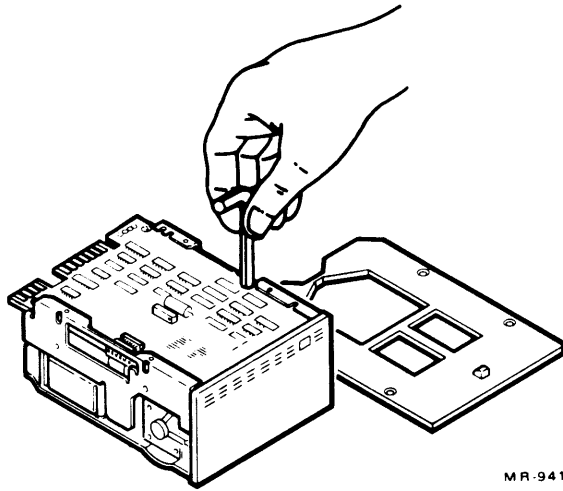

Figure 5-10 RD51-A Fixed Disk Drive Read/Write Printed Circuit Board Screw Removal

- Disconnect connector P5 located on the side of the read/write printed circuit board, as shown in Figure 5-11.

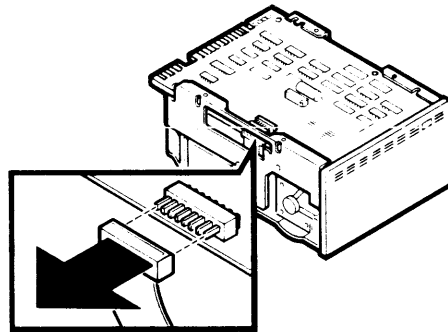
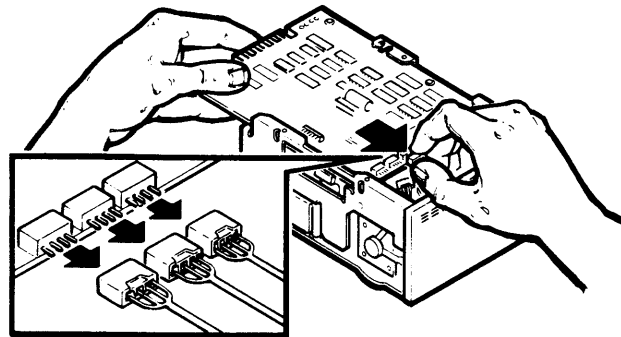

Figure 5-11 RD51-A Fixed Disk Drive Connector P5 Removal

4. Disconnect connectors P8, P7, and P6 located on the front of the read/write printed circuit board, as shown in Figure 5-12.



MR-9413

Figure 5-12 RD51-A Fixed Disk Drive Connectors P8, P7, and P6 Removal

5. Disconnect connector P4, as shown in Figure 5-13. P4 is a 2-wire connector located on the rear of the read/write printed circuit board and near the dc power connector.

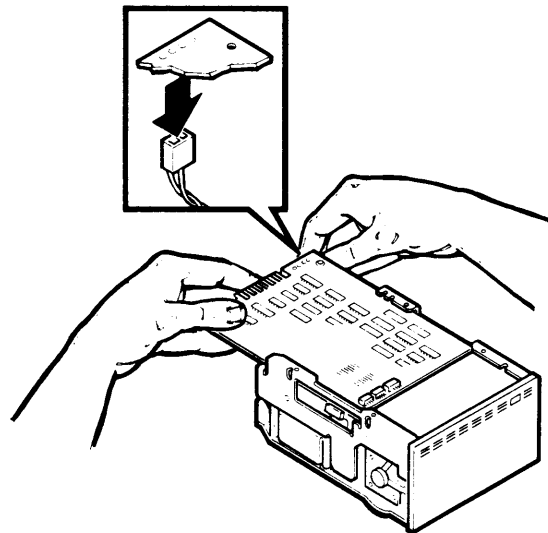

MR-9414

Figure 5-13 RD51-A Fixed Disk Drive Connector P4 Removal

6. Remove the fixed disk drive read/write printed circuit board, as shown in Figure 5-14.

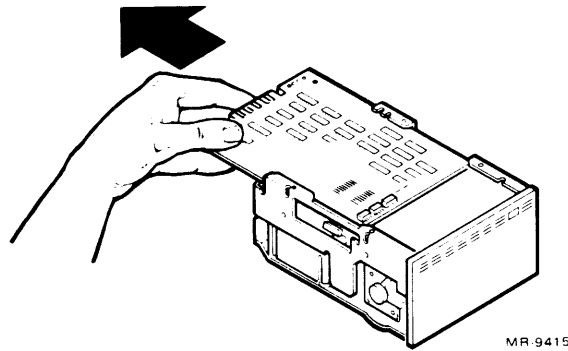

Figure 5-14 RD51-A Fixed Disk Drive Read/Write Printed Circuit Board Removal

7. Make sure the configuration of jumpers on the replacement printed circuit board is as listed in Table 5-7. Replace the board by reversing steps 1 through 6.
8. Replace the fixed disk drive by reversing steps 2 through 10 of the procedure in Paragraph 5.8.5.

5.8.5.2 RD51-A Fixed Disk Drive Formatting Procedure –The Field Service test diskettes provide the XXDP+ program necessary to format the drive. In response to the . (period) prompt, type **R ZRQB??**

.R ZRQB?? <CR>

(The question marks will allow any revision of the program to be used.) A response similar to the following appears on the terminal.

```
DRSDO
ZRQAXX-X-X          (where X is the current revision information)
RD51 FORMAT PROGRAM
UNIT IS RD51
DR>
DRSD0
RDRX -A-0
RD51 DISK FORMATTER
UNIT IS RQDX1 DISK DRIVE SUBSYSTEM
RSTRT ADR 147670
```

You must respond to this prompt with a command to run the program, for example:

DR>STA (to cause the program to run one pass)

You are then asked the following.

CHANGE HW (L) ? N

CHANGE SW (L) ? N

ENTER UNIT TO BE FORMATTED (D) ? 0

USE EXISTING BAD BLOCK INFORMATION ? N

USE DOWN LINE LOAD (L) N ? N

CONTINUE IF BAD BLOCK INFORMATION IS INACCURATE (L) N ? Y

ENTER 8 CHARACTER SERIAL NUMBER (A) ? #####

ENTER DATE IN MM-DD-YY FORMAT (A) ? 02-19-83

As shown above, the response to most questions is no. The unit number must be specified as 0, and the current date should be entered.

The format routine takes approximately 11 minutes to complete, and its successful completion results in a message similar to the following.

FORMAT COMPLETED

If the formatting process is not successful, an error message appears on the terminal. Refer to the individual program listing to use this message (if necessary) to isolate the failure or to determine which FRU to replace.

5.8.6 RX50-AA Diskette Drive Removal and Replacement Procedure

Use the following procedure to remove and replace the RX50-AA diskette drive.

1. Make sure the ac power cord is unplugged.
2. Remove the front plastic cover by holding each end of the cover and pulling it off.
3. Remove the rear plastic cover by holding each end of the cover and pulling it off.
4. Remove the front chassis retaining bracket by removing the four screws that hold it to the plastic case.

NOTE

Before sliding the chassis forward (step 5), be sure there is enough slack in the cables in the back of the unit.

5. Slide the chassis forward, as shown in Figure 5-15, until all the front top cover screws are accessible.

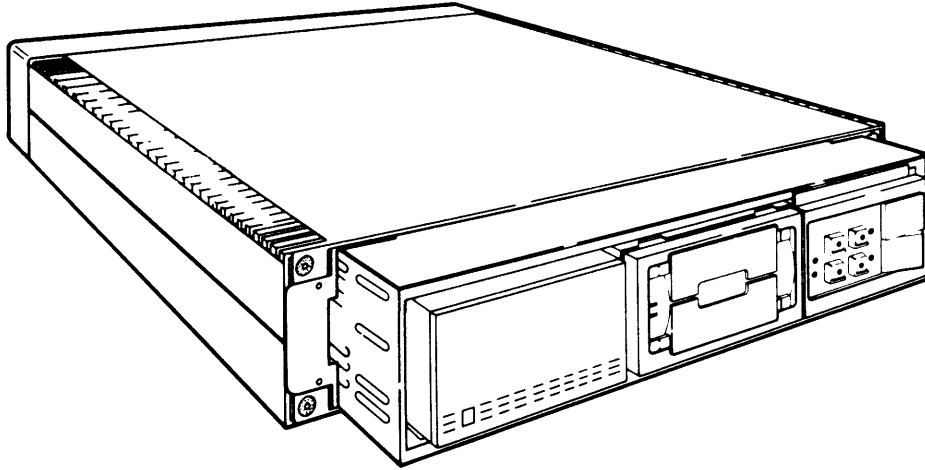

Figure 5-15 Front Top Cover Access

MR-10272

6. Remove the front top sheet metal cover from the chassis.
7. Disconnect the signal cable and the dc power cable from the diskette drive. Disconnect the cables by pulling straight up on each cable's connector, as shown in Figure 5-16.

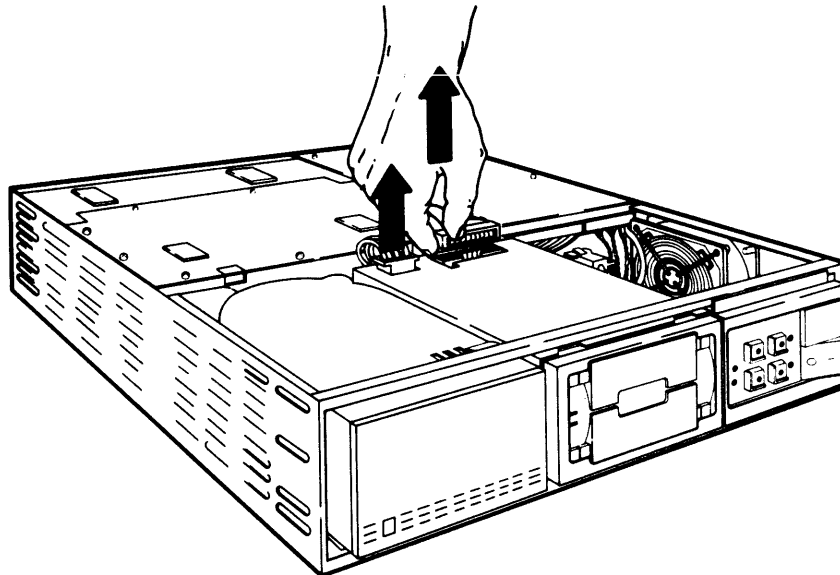

Figure 5-16 RX50-AA Diskette Drive Signal and Power Cable Removal

MR-9437

8. Find the release tab at the front of the diskette drive, as shown in Figure 5-17. Push down on the release tab and slide the diskette drive forward out of the chassis as shown in Figure 5-18.

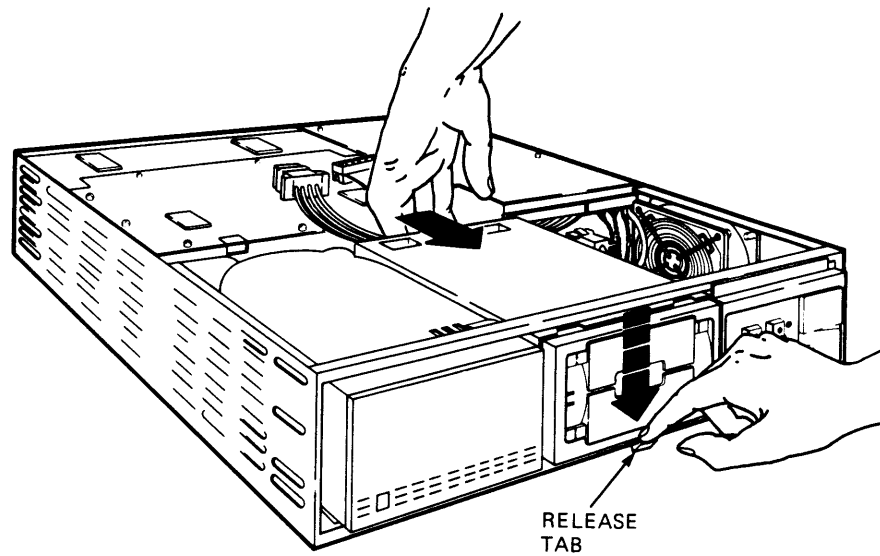

Figure 5-17 RX50-AA Diskette Drive Release Tab

MR-9436

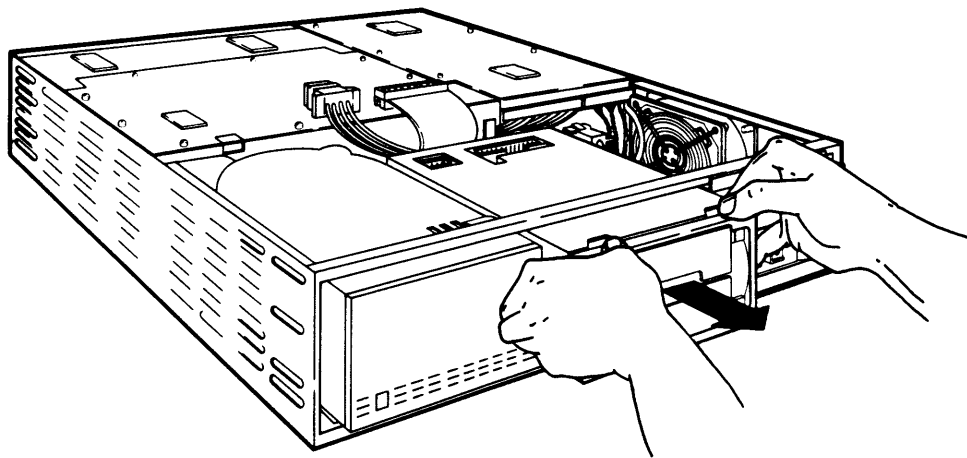

Figure 5-18 RX50-AA Diskette Drive Removal

MR-9438

9. Install the replacement RX50-AA diskette drive by reversing steps 2 through 8.

NOTE

Remove the cardboard shipping insert from the replacement RX50-AA diskette drive after installing the signal and power cables. Be sure to install the cardboard shipping insert into the diskette drive that was removed.

5.8.7 H7864 Power Supply Removal and Replacement Procedure

Use the following procedure to remove and replace the H7864 power supply.

NOTE

The power supply is a complete field-replaceable unit (FRU). It is not adjustable and does not contain replaceable printed circuit boards. The +5 Vdc and +12 Vdc power regulators are fixed and, therefore, not adjustable. Voltage tolerances are +4.875 Vdc to +5.125 Vdc for the +5 Vdc regulator, and +11.7 Vdc to +12.3 Vdc for the +12 Vdc regulator. Ripple is 50 mV peak-to-peak at +5 Vdc, and 75 mV peak-to-peak at +12 Vdc.

1. Make sure the ac power cord is unplugged.
2. Remove the front plastic cover by holding each end of the cover and pulling it off.
3. Remove the rear plastic cover by holding each end of the cover and pulling it off.
4. Disconnect the ac power cord (connector J12) located at the rear of the power supply. Refer to Figure 5-19.
5. If a remote power controller is used, disconnect the remote power controller cable located at the rear of the power supply. Refer to Figure 5-19.

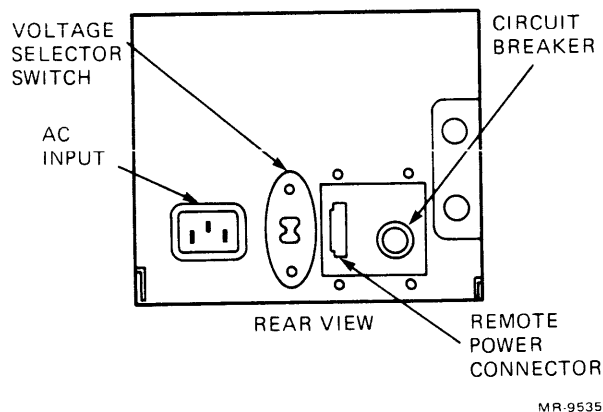
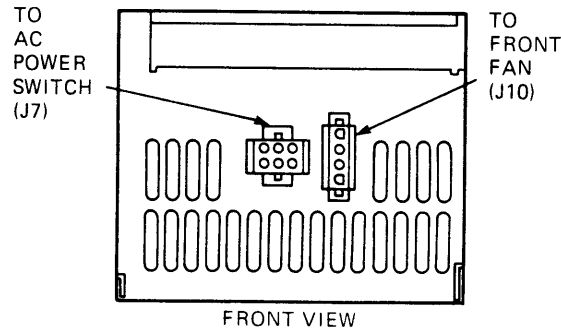

Figure 5-19 H7864 Power Supply (Rear View)

6. Remove all cables connected to the patch and filter panel assembly. Note their original positions.
7. Remove the rear chassis retaining bracket by removing the four screws that hold it to the plastic case.
8. Slide the chassis out of the plastic case.
9. Open the patch and filter panel assembly by loosening the two (captive) screws on the assembly.
10. Remove the front top sheet metal cover from the chassis.

11. Remove the 18-pin system backplane power connector (connector J9) from the power supply. This connector is located on the top front of the power supply, as shown in Figure 5-20.



MR-9534

Figure 5-20 H7864 Power Supply (Front View)

12. Disconnect the 9-pin mass storage power connector (connector J8) from the power supply. This connector is located to the right of the 18-pin system backplane power connector.
13. Disconnect the 4-prong in-line fan power connector (connector J10). Figure 5-20 shows its location on the front of the power supply.
14. Disconnect the 6-prong ac power switch connector (connector J7), also located on the front of the power supply, as shown in Figure 5-20.
15. Remove the five Phillips screws that hold the power supply to the chassis.
16. Carefully lift the power supply assembly out of the chassis and rest it on top of the rear top sheet metal cover. The side view of the power supply is shown in Figure 5-21.

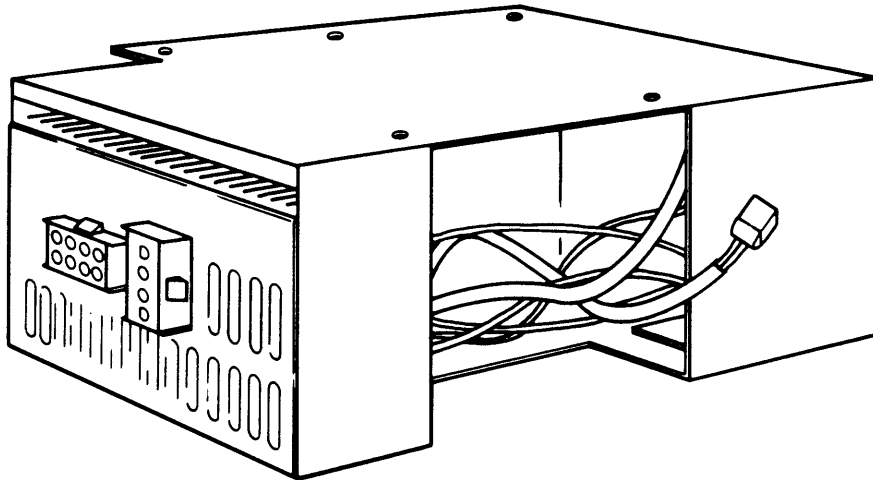

MR-9536

Figure 5-21 H7864 Power Supply (Side View)

17. Disconnect the power connector from the fan.
18. Install a new power supply by reversing steps 2 through 17.

NOTE

Be sure the voltage selector switch (shown in Figure 5-19) is set correctly for local requirements. (The number displayed on the switch is the voltage selected.)

5.8.7.1 System Unit Front Fan Removal and Replacement Procedure – Use the following procedure to remove and replace the front fan.

NOTE

The fans (part number 12-17556-01) in the MICRO/PDP-11 system are identical. However, their locations and connections to the power supply cause them to run at different speeds.

1. Make sure the ac power cord is unplugged.
2. Remove the front plastic cover by holding each end of the cover and pulling it off.
3. Remove the rear plastic cover by holding each end of the cover and pulling it off.
4. Remove the front chassis retaining bracket by removing the four screws that hold it to the plastic case.

NOTE

Before sliding the chassis forward (step 5), be sure there is enough slack in the cables in the back of the unit.

5. Slide the chassis forward until all the front top cover screws are accessible.
6. Remove the front top sheet metal cover from the chassis.
7. Remove the RX50-AA diskette drive as described in Paragraph 5.8.6.
8. Disconnect the power cord from the fan.
9. Remove the four screws that hold the fan to the chassis.
10. Remove the fan.
11. Remove the fan guard from the intake side of the removed fan and install the guard on the replacement fan. Install the replacement fan by reversing steps 2 through 10, making sure that the outside fan guard is located between the fan and the chassis. Also, make sure the direction of airflow is away from the fixed disk drive and diskette drive, and that the power connector is positioned so it is closest to the bottom of the power supply.

CAUTION

When replacing the dc fan power cable, observe the polarity of the connector because it is not keyed. The curve of the cable connector must match the curve of the fan housing, as shown in Figure 5-22.

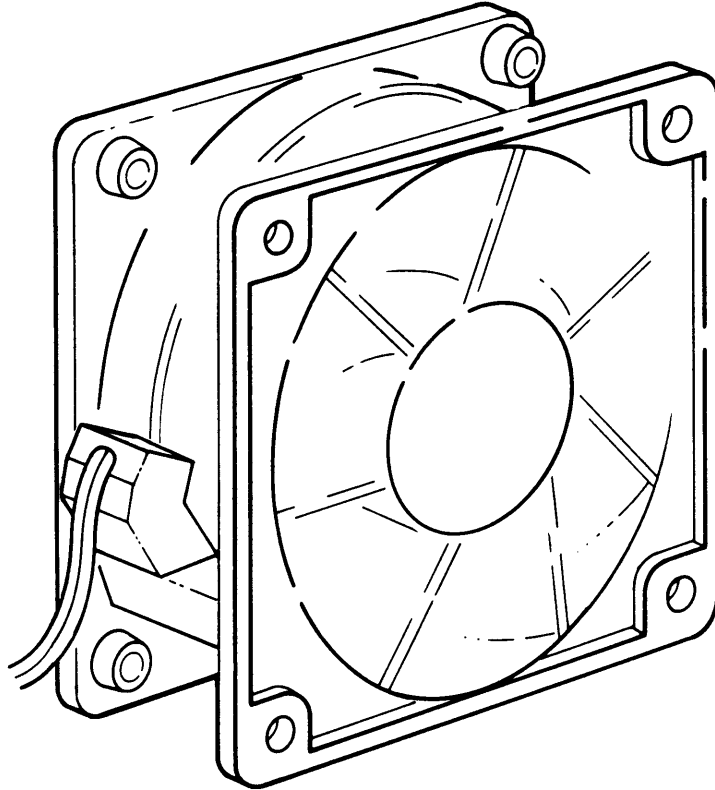

MR-10269

Figure 5-22 Fan Power Cable Connection

5.8.7.2 System Unit Rear Fan Removal and Replacement Procedure – Use the following procedure to remove and replace the rear fan.

NOTE

The fans (part number 12-17556-01) in the MICRO/PDP-11 system are identical. However, their locations and connections to the power supply cause them to run at different speeds.

1. Make sure the ac power cord is unplugged.
2. Remove the H7864 power supply from the chassis as described in Paragraph 5.8.7.
3. Remove the four screws that hold the fan to the chassis.
4. Remove the fan.

5. Install the replacement fan by reversing steps 2 through 4. Make sure the direction of airflow is away from the power supply.

CAUTION

When replacing the dc fan power cable, observe the polarity of the connector because it is not keyed. The curve of the cable connector must match the curve of the fan housing, as shown in Figure 5-22.

5.8.8 Backplane Assembly Removal and Replacement Procedure

Use the following procedure to remove and replace the backplane assembly.

1. Make sure the ac power cord is unplugged.
2. Remove the front plastic cover by holding each end of the cover and pulling it off.
3. Remove the rear plastic cover by holding each end of the cover and pulling it off.
4. Remove all the cables connected to the rear patch and filter panel assembly. Note their original positions.
5. Remove the rear chassis retaining bracket by removing the four screws that hold the bracket to the plastic case.
6. Remove the chassis from the plastic case and put it down on a flat work area.
7. Open the patch and filter panel assembly by loosening the two (captive) screws on the assembly and swinging it open.
8. Remove both top sheet metal covers.
9. Remove all cables connected to the backplane and the signal distribution printed circuit board. Note their original positions.
10. Remove the RD51-A fixed disk drive as described in Paragraph 5.8.5.
11. Remove the RX50-AA diskette drive as described in Paragraph 5.8.6.
12. Remove all the modules from the backplane.
13. Remove the four screws that hold the backplane assembly to the chassis.
14. Remove the 50-conductor Massbus cable connected to the signal distribution board.
15. Pivot the CD section end of the backplane assembly 45 degrees toward the patch and filter panel assembly. Remove the backplane assembly by lifting it straight out of the chassis.
16. Install the replacement backplane assembly by reversing steps 2 through 15.

5.8.9 Control Panel (54-15610) Removal and Replacement Procedure

Use the following procedure to remove and replace the control panel.

1. Make sure the ac power cord is disconnected.
2. Remove the front plastic cover by holding each end of the cover and pulling it off.
3. Remove the rear plastic cover by holding each end of the cover and pulling it off.
4. Remove the front chassis retaining bracket by removing the four screws that hold the bracket to the plastic case.
5. Remove the five Phillips screws that hold the control panel to the chassis.
6. Remove the Berg type connector from the control panel printed circuit board.
7. Install the replacement control panel by reversing steps 2 through 6.

NOTE

The 2-position line time clock (LTC) switch (switch 1) is used to enable or disable the LTC function. Setting switch 1 to the on position enables the LTC to function under software control. Setting switch 1 to the off position disables the LTC function. The other 2-position switch (switch 2) is not used.

CHAPTER 6

SYSTEM OPTIONS AND RULES FOR EXPANSION

6.1 INTRODUCTION

The number of optional modules you can add to the MICRO/PDP-11 system depends on two things: the space available in the backplane and the power available from the power supply. The options listed in this chapter are those recommended by Digital for expansion of the MICRO/PDP-11 system. You can obtain additional information on MICRO-PDP-11 system options from the *MICRO/PDP-11 System Options Manual* (EK-OLCP5-OD).

6.2 CENTRAL PROCESSING UNIT OPTIONS

The basic MICRO/PDP-11 system's CPU can be expanded by the addition of floating-point capability. Two options recommended for use in the MICRO/PDP-11 system provide both single- and double-precision floating-point processing: the KEF11-AA and the FPF11. Another CPU option, the KEF11-BB, adds character string instructions to the basic PDP-11 instruction set.

6.2.1 KEF11-AA Floating-Point Option

The KEF11-AA option performs hardware operations on 32-bit and 64-bit floating-point numbers. This option provides up to 17 digits of precision as well as integer-to-floating-point conversions. The KEF11-AA option's microcode that implements these functions resides in two chips on one 40-pin package. This package mounts directly on the KDF11-BE central processing unit (CPU) module (M8189).

6.2.2 FPF11 Floating-Point Option Module

The FPF11 option module performs hardware operations on 32-bit and 64-bit floating-point numbers. This option provides up to 17 digits of precision as well as integer-to-floating-point conversions. The FPF11 option executes instructions approximately six times faster than the KEF11-AA option does. The FPF11 option's microcode that implements these functions resides on one quad-height module that is mounted in the backplane slot adjacent to the KDF11-BE central processing unit (CPU) module (M8189).

NOTE

An open slot (space) must be left between the KDF11-BE CPU and the FPF11 module. In addition, a 67272 grant card must be placed in slot A-2.

6.2.3 KEF11-BB Commercial Instruction Set Option

The KEF11-BB commercial instruction set (CIS) is a microcode option that adds character string instructions to the basic PDP-11 instruction set. The character string operations conveniently implement most of the common functions encountered in commercial data and text processing applications. The CIS microcode resides in six MOS/LSI chips mounted on a single 40-pin package.

6.3 MEMORY EXPANSION

The versions of the MSV11-P memory module that may be added to the MICRO/PDP-11 system are listed in Table 6-1.

Table 6-1 MSV11-P Memory Module Versions

Option Designation	Module Designation	Storage Capacity	MOS Chips	Module Population	Number of Rows
MSV11-PL	M8067-LA	256 K words (512 K bytes)	64 K	Full	8
MSV11-PK	M8067-KA	128 K words (256 K bytes)	64 K	Half	4

Any memory module added to the system needs to be assigned a unique CSR address. The possible addresses and their corresponding jumper configurations for the M8067-KA memory module are listed in Table 6-2. Each M8067-KA memory module installed in a system must also be jumpered for its own starting address. Table 6-3 lists jumper configurations used to select the 256 K word-range address (first address range) for each M8067-KA memory module added. The 8 K boundary within the 256 K word-range (partial starting address) is selected by configuring the jumpers as listed in Table 6-4. Other memory options that may be added to the MICRO/PDP-11 system are listed in Table 6-5.

Table 6-2 M8067-KA Memory Module CSR Address Selection

Module Number	Large System LSI-11 Bus Address	Small System LSI-11 Bus Address	Jumper to Ground (Pin E)			
			D	D	B	A
1	17772100	772100	Out	Out	Out	Out
2	17772102	772102	Out	Out	Out	In
3	17772104	772104	Out	Out	In	Out
4	17772106	772106	Out	Out	In	In
5	17772110	772110	Out	In	Out	Out
6	17772112	772112	Out	In	Out	In
7	17772114	772114	Out	In	In	Out
8	17772116	772116	Out	In	In	In
9	17772120	772120	In	Out	Out	Out
10	17772122	772122	In	Out	Out	In
11	17772124	772124	In	Out	In	Out
12	17772126	772126	In	Out	In	In
13	17772130	772130	In	In	Out	Out
14	17772132	772132	In	In	Out	In
15	17772134	772134	In	In	In	Out
16	17772136	772136	In	In	In	In

**Table 6-3 M8067-KA Memory Module
Starting Address Configurations (FAR)**

First Address Ranges (FAR)		Jumpers to Ground (Pin Y)		
Decimal K Words	Octal K Words	Pin X (A21)	Pin W (A20)	Pin V (A19)
000-248	0000 0000-0174 0000	Out	Out	Out
256-504	0200 0000-0374 0000	Out	Out	In
512-760	0400 0000-0574 0000	Out	In	Out
768-1016	0600 0000-0774 0000	Out	In	In
1024-1272	1000 0000-1174 0000	In	Out	Out
1280-1528	1200 0000-1374 0000	In	Out	In
1526-1784	1400 0000-1574 0000	In	In	Out
1742-2040	1600 0000-1774 0000	In	In	In

Table 6-4 M8067-KA Starting Address Configurations (PSA)

Partial Starting Address (PSA)		Jumpers to Ground (Pin R)				
Decimal K Words	Octal K Words	Pin P (A18)	Pin N (A17)	Pin M (A16)	Pin L (A15)	Pin T (A14)
0	0000 0000	Out	Out	Out	Out	Out
8	0004 0000	Out	Out	Out	Out	In
16	0010 0000	Out	Out	Out	In	Out
24	0014 0000	Out	Out	Out	In	In
32	0020 0000	Out	Out	In	Out	Out
40	0024 0000	Out	Out	In	Out	In
48	0030 0000	Out	Out	In	In	Out
56	0034 0000	Out	Out	In	In	In
64	0040 0000	Out	In	Out	Out	Out
72	0044 0000	Out	In	Out	Out	In
80	0050 0000	Out	In	Out	In	Out
88	0054 0000	Out	In	Out	In	In
96	0060 0000	Out	In	In	Out	Out
104	0064 0000	Out	In	In	Out	In
112	0070 0000	Out	In	In	In	Out
120	0074 0000	Out	In	In	In	In
128	0100 0000	In	Out	Out	Out	Out
136	0104 0000	In	Out	Out	Out	In
144	0110 0000	In	Out	Out	In	Out
156	0114 0000	In	Out	Out	In	In
160	0120 0000	In	Out	In	Out	Out
168	0124 0000	In	Out	In	Out	In
176	0130 0000	In	Out	In	In	Out
184	0134 0000	In	Out	In	In	In

Table 6-4 M8067-KA Starting Address Configurations (PSA)(Cont)

Partial Starting Address (PSA)		Jumpers to Ground (Pin R)				
Decimal K Words	Octal K Words	Pin P (A18)	Pin N (A17)	Pin M (A16)	Pin L (A15)	Pin T (A14)
192	0140 0000	In	In	Out	Out	Out
200	0144 0000	In	In	Out	Out	In
208	0150 0000	In	In	Out	In	Out
216	0154 0000	In	In	Out	In	In
224	0160 0000	In	In	In	Out	Out
232	0164 0000	In	In	In	In	In
240	0170 0000	In	In	In	In	Out
248	0174 0000	In	In	In	In	In

Table 6-5 Additional MICRO/PDP-11 System Memory Options

Model Designation	Capacity (K bytes)	Address Range (bits)	Chip	Battery Backup Hooks	Parity	CSR	On-Board Refresh
MCV11-DA	8	22	16 K MOS	*			
MCV11-DC	2	22	16 K MOS	*			
MSV11-LF	128	22	64 K	*	*	*	*
MSV11-LK	256	22	64 K	*	*	*	*
MSV11-PK	256	22	64 K	*	*	*	*
MSV11-PL	512	22	64 K	*	*	*	*
MRV11-D	64 (PROM)	22	Customer- supplied PROMs				

*Included

6.4 COMMUNICATIONS HARDWARE OPTIONS

Figure 6-1 lists a variety of communication hardware options that may be used to expand the MICRO/PDP-11 system.

MODEL	NUMBER OF LINES	DUPLEX MODE	MAX. LINE SPEED (B/S)	LINE INTERFACE *	BUS SUPPORT	CRC PROCESSING	TRANSMISSION MODE	EXTERNAL CABLING INCLUDED
DLV11	1	H/F	9,600	20 MA EIA/CCITT	LSI-11 BUS	NO	ASYNCHRONOUS	NOT INCLUDED
DLV11-EB	1	H/F	19,200	EIA	LSI-11 BUS	NO	ASYNCHRONOUS	BC01V-25
DLV11-E	1	H/F	19,200	EIA	LSI-11 BUS	NO	ASYNCHRONOUS	NOT INCLUDED
DLV11-FB	1	H/F	19,200	EIA/CCITT	LSI-11 BUS	NO	ASYNCHRONOUS	BC03L-05
DLV11-FA	1	H/F	19,200	20 MA	LSI-11 BUS	NO	ASYNCHRONOUS	BC05M-04
DLV11-F	1	H/F	19,200	20 MA EIA/CCITT	LSI-11 BUS	NO	ASYNCHRONOUS	NOT INCLUDED
DZV11-B	4	H/F	9,600	EIA/CCITT	LSI-11 BUS	NO	ASYNCHRONOUS	BC11U
DLV11-J	4	H/F	38,400	EIA/CCITT	LSI-11 BUS	NO	ASYNCHRONOUS	NOT INCLUDED
DUV11-DA	1	H/F	9,600	EIA/CCITT	LSI-11 BUS	NO	SYNCHRONOUS	BC05C-25
DPV11-DB	1	H.F	56,000	EIA	LSI-11 BUS	YES	SYNCHRONOUS	BC26L-25

* UNLESS OTHERWISE SPECIFIED, EIA/CCITT INDICATES CONFORMANCE TO EIA RS-232C/CCITT V.24.

MR 9559

Figure 6-1 Communications Hardware Options

6.5 MASS STORAGE OPTIONS

Table 6-6 lists a variety of mass storage options that may be used to expand the MICRO/PDP-11 system. The devices listed in this table are supported by the KDF11-BE boot/diagnostic ROM (refer to Table 2-2).

Table 6-6 Mass Storage Options

Feature	TU58-EP	RXV21-ES	RLV22-AP	RX50-AA	RD51-A
Storage type	Tape	Diskette	Disk	Diskette	Fixed disk
Formatted capacity per drive	512 KB	512 KB	10.4 MB	2x400 KB	10 MB
DMA capability	No	Yes (18-bit)	Yes (22-bit)	Yes (22-bit) block mode	Yes (22-bit) block mode

APPENDIX A BACKPLANE PIN ASSIGNMENTS

Digital Equipment Corporation's plug-in modules, including those installed in the MICRO/PDP-11 system, all use the same contact (pin) identification system. Figure A-1 shows the contact finger identification for a typical quad-height module. Each connector contains 36 lines (18 lines on each side of the printed circuit board). Tables A-1 to A-8 list the backplane pin assignments for each module installed in the MICRO/PDP-11 system.

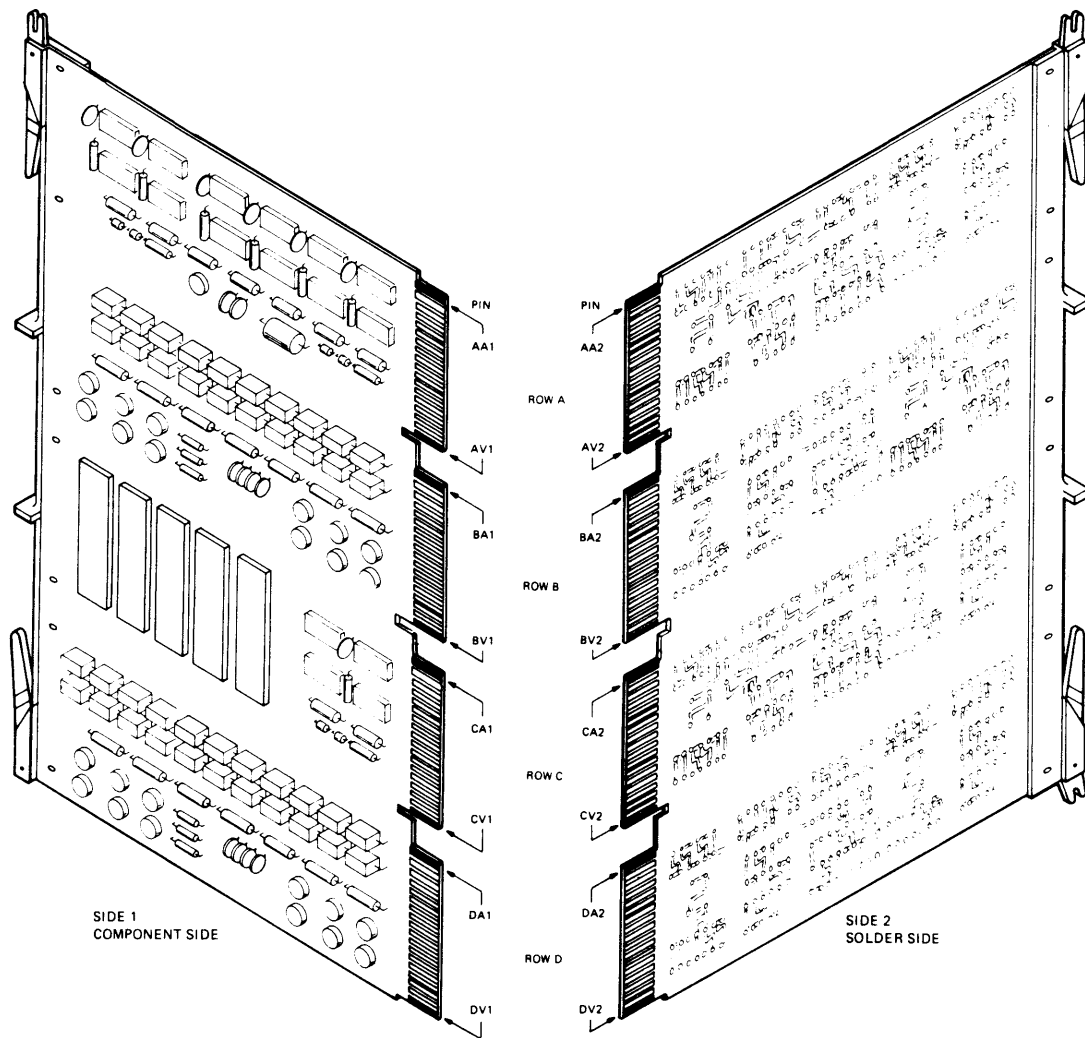

Figure A-1 Quad Module Contact Finger Identification

**Table A-1 KDF11-BE (M8189) Module Backplane Pin Assignments
(Rows A and B)**

Bus Pin	A Connector:		B Connector:	
	Side 1	Side 2	Side 1	Side 2
A	BIRQ5 L	+5 V	BDCOK H	+5 V
B	BIRQ6 L	-	BPOK H	-
C	BDAL16 L	GND	BDAL18 L	GND
D	BDAL17 L	+12 V	BDAL19 L	+12 V
E	-	BDOUT L	BDAL20 L	BDAL02 L
F	SRUN L	BRPLY L	BDAL21 L	BDAL03 L
H	SRUN L	BDIN L	PUP CD1J L	BDAL04 L
J	GND	BSYNC L	GND	BDAL05 L
K	-	BWTBT L	-	BDAL06 L
L	-	BIRQ4 L	-	BDAL07 L
M	GND	MCENB H	GND	BDAL08 L
N	BDMR L	BIAK L	BSACK L	BDAL09 L
P	BHALT L	BBS7 L	BIRQ7 L	BDAL10 L
R	BREF L	-	BEVENT L	BDAL11 L
S	-	BDMGO L	-	BDAL12 L
T	GND	BINIT L	GND	BDAL13 L
U	-	BDAL00 L	-	BDAL14 L
V	-	BDAL01 L	+5 V	BDAL15 L

- Pins not used.

**Table A-2 KDF11-BE (M8189) Module Backplane Pin Assignments
(Rows C and D)**

Bus Pin	C Connector:		D Connector:	
	Side 1	Side 2	Side 1	Side 2
A	-	+5 V	-	+5 V
B	-	-	-	-
C	-	GND	-	GND
D	-	-	-	-
E	-	-	-	-
F	-	-	-	-
H	-	-	-	-
J	-	-	-	-
K	-	-	-	-
L	-	-	-	-
M	-	BIAKI L	-	-
N	-	BIAKO L	-	-
P	-	-	-	-
R	-	BDMGI L	-	-
S	-	BDMGO L	-	-
T	GND	-	GND	-
U	-	-	-	-
V	-	-	-	-

- Pins not used.

**Table A-3 MSV11-PK (M8067) Module Backplane Pin Assignments
(Rows A and B)**

Bus Pin	A Connector:		B Connector:	
	Side 1	Side 2	Side 1	Side 2
A	-	+5 V	BDCOK H	+5 V
B	-	-	-	-
C	BDAL16 L	GND	BDAL18 L	GND
D	BDAL17 L	+12 V	BDAL19 L	+12 V
E	+5 V BBU	BDOUT L	BDAL20 L	BDAL02 L
F	-	BRPLY L	BDAL21 L	BDAL03 L
H	-	BDIN L	-	BDAL04 L
J	GND	BSYNC L	GND	BDAL05 L
K	REFKILL	BWTBT L	-5 V MEAS*	BDAL06 L
L	-	-	-5 V MARGIN*	BDAL07 L
M	GND	BIAKI L**	GND	BDAL08 L
N	-	BIAKO L**	-	BDAL09 L
P	-	BBS7 L	-	BDAL10 L
R	BREF L	BDMGI L**	-	BDAL11 L
S	+12 V BBU	BDMGO L**	-	BDAL12 L
T	GND	BINIT L	GND	BDAL13 L
U	SA16K***	BDAL00 L	-	BDAL14 L
V	+5 V BBU	BDAL01 L	+5 V	BDAL15 L

- Pins not used.

* Must be hardwired on backplane or damage to MOS device may result.

** Hardwired via etch on module.

*** When SA16K (starting address 16K) jumper is removed, there is no connection to this pin (used in memory test only).

**Table A-4 MSV11-PK (M8067) Module Backplane Pin Assignments
(Rows C and D)**

Bus Pin	C Connector:		D Connector:	
	Side 1	Side 2	Side 1	Side 2
A	-	+5 V	-	-
B	-	-	-	-
C	-	-	-	-
D	-	-	-	-
E	-	-	-	-
F	-	-	-	-
H	-	-	-	-
J	-	-	-	-
K	-	-	-	-
L	-	-	-	-
M	-	BIAKI L*	-	-
N	-	BIAKO L*	-	-
P	-	-	-	-
R	-	BDMGI L*	-	-
S	-	BDMGO L*	-	-
T	-	-	-	-
U	-	-	-	-
V	-	-	-	-

- Pins not used.

* Jumpered on module.

**Table A-5 DZV11-A (M7957) Module Backplane Pin Assignments
(Rows A and B)**

Bus Pin	A Connector:		B Connector:	
	Side 1	Side 2	Side 1	Side 2
A	-	+5 V	BDCOK H	+5 V
B	-	-	-	-
C	-	GND	-	GND
D	-	-	-	+12 V
E	-	BDOUT L	-	BDAL02 L
F	-	BRPLY L	-	BDAL03 L
H	-	BDIN L	-	BDAL03 L
J	-	BSYNC L	-	BDAL05 L
K	-	BWTBT L	-	BDAL06 L
L	-	BIRQ L	-	BDAL07 L
M	-	BIAKI L	-	BDAL08 L
N	-	BIAKO L	-	BDAL09 L
P	-	BBS7 L	-	BDAL10 L
R	-	BDMGI L	-	BDAL11 L
S	-	BDMGO L	-	BDAL12 L
T	GND	BINIT L	GND	BDAL13 L
U	-	BDAL00 L	-	BDAL14 L
V	-	BDAL01 L	+5 V	BDAL15 L

- Pins not used.

**Table A-6 DZV11-A (M7957) Module Backplane Pin Assignments
(Rows C and D)**

Bus Pin	C Connector:		D Connector:	
	Side 1	Side 2	Side 1	Side 2
A	-	+5 V	-	+5 V
B	-	-	-	-
C	-	-	-	-
D	-	-	-	-
E	-	-	-	-
F	-	-	-	-
H	-	-	-	-
J	-	-	-	-
K	-	-	-	-
L	-	-	-	-
M	-	BIAKI L*	-	-
N	-	BIAKO L*	-	-
P	-	-	-	-
R	-	BDMGI L*	-	-
S	-	BDMGO L*	-	-
T	-	-	-	-
U	-	-	-	-
V	-	-	-	-

- Pins not used.
* Jumpered on module.

**Table A-7 RQDX1 (M8639) Module Backplane Pin Assignments
(Rows A and B)**

Bus Pin	A Connector:		B Connector:	
	Side 1	Side 2	Side 1	Side 2
A	-	+5 V	-	+5 V
B	-	-	BPOK H	-
C	BDAL16 L	GND	BDAL18 L	GND
D	BDAL17 L	+12 V	BDAL19 L	+12 V
E	-	BDOUT L	BDAL20 L	BDAL02 L
F	-	BRPLY L	BDAL21 L	BDAL03 L
H	-	BDIN L	-	BDAL04 L
J	GND	BSYNC L	GND	BDAL05 L
K	-	BWTBT L	-	BDAL06 L
L	-	BIRQ4 L ✓	-	BDAL07 L
M	GND	BIAKI L	GND	BDAL08 L
N	BDMR L	BIAKO L	BSACK L	BDAL09 L
P	-	BBS7 L	-	BDAL10 L
R	BREF L	BDMGI L	-	BDAL11 L
S	-	BDMGO L	-	BDAL12 L
T	GND	BINIT L	GND	BDAL13 L
U	-	BDAL00 L	-	BDAL14 L
V	-	BDAL01 L	+5 V	BDAL15 L

- Pins not used.

**Table A-8 RQDX1 (M8639) Module Backplane Pin Assignments
(Rows C and D)**

Bus Pin	C Connector:		D Connector:	
	Side 1	Side 2	Side 1	Side 2
A	-	+5 V	-	+5 V
B	-	-	-	-
C	-	GND	-	GND
D	-	-	-	-
E	-	-	-	-
F	-	-	-	-
H	-	-	-	-
J	GND	-	GND	-
K	-	-	-	-
L	-	-	-	-
M	GND	BIAKI L*	GND	-
N	-	BIAKO L*	-	-
P	-	-	-	-
R	-	BDMGI L*	-	-
S	-	BDMGO L*	-	-
T	GND	-	GND	-
U	-	-	-	-
V	-	-	-	-

- Pins not used.

* Jumpered on module.

APPENDIX B

ON-LINE DEBUGGING TECHNIQUE (ODT) COMMANDS

A portion of the microcode on the KDF11-BE CPU module emulates the capability normally found on a programmer's console. The CPU interprets streams of ASCII characters from the console terminal as console commands. This feature is called the microcode on-line debugging technique, or micro-ODT. The KDF11-BE module's micro-ODT accepts 18-bit addresses, allowing it to access 248 K bytes of memory and the 8 K-byte I/O page.

The MICRO/PDP-11 system enters console emulator mode when any of the following occurs.

1. The program executes a halt instruction.
2. The system detects an error condition.
3. You press the halt switch on the control panel.

When the system halts program and enters console emulator mode, the system displays the following.

```
nnnnnn  
@
```

The number nnnnnn is the octal location of the next instruction to be executed, and the @ is the ODT prompt character. You may now type any ODT command. The ODT command set is listed in Table B-1.

Table B-1 Console ODT Commands

Command	Symbol	Function
Slash	/	Prints the contents of a specified location.
Carriage return	<CR>	Closes an open location.
Line feed	<LF>	Closes an open location and then opens the next contiguous location.
Internal register designator	\$ or R	Opens a specific CPU register.
Processor status word designator	S	Opens the PS; must follow a \$ or R command.
Go	G	Starts execution of a program.
Proceed	P	Resumes execution of a program.
Binary dump	CTRL/S	For manufacturing use only.
(Reserved)	H	Reserved for use by Digital. (Causes the CPU to execute a microcode routine that, in effect, does nothing.)

APPENDIX C GLOSSARY

ANSI – The acronym for American National Standards Institute.

Answerback – A preprogrammed response from a terminal.

ASCII – 1) The acronym for American Standard Code for Information Interchange. 2) A 7- or 8-bit standard for transmission of data for processing.

Backplane – The connector block section of the system where printed circuit boards are inserted.

Baud rate – Synonymous with signal events (usually bits) per second; used as a measure of serial data flow between a computer and/or communication devices.

Bootstrap – A programmed routine consisting of enough instructions to load and transfer control to an input/output device's program. The routine is started by a switch or automatically when the computer is turned on.

Buffer control – A temporary storage memory used to equalize different operating speeds.

Bus error trap – A high-priority interrupt that halts the processor routine and initiates a subroutine.

Byte – A group of binary bits used to represent a single character.

Channel – A path for electrical transmission between two or more points.

Control panel – The part of the system that permits the monitoring and manipulation of an operation through the use of control switches and indicators.

CPU – 1) The acronym for central processing unit. 2) The part of the computer that contains the arithmetic and logical unit, instruction control unit, timing generators, and input/output interfaces of the basic system.

Diagnostic program – A program designed to detect and/or isolate a malfunction in a device, printed circuit board, or component.

DMA – 1) The acronym for direct memory access. 2) A facility that allows input/output transfers to bypass the CPU's general registers and go directly to/from memory.

EIA – The acronym for Electronic Industries Association.

EIA interface – The standard code defined by the Electronic Industries Association for use in data exchange.

Error message – A printed statement indicating the system has detected a mistake or malfunction.

Floating-point processing – A method of calculation that automatically moves the decimal point.

FRU – Field-replaceable unit.

Hardcopy – Output in a permanent form (usually on paper or paper tape) rather than in temporary form (such as a visual display on a video terminal).

Head – The part in a disk(ette) drive or magnetic tape drive that reads, records, and erases data on the storage medium being used.

Instruction set – A group of commands that tells the computer what operation to perform.

Input/output (I/O) – A descriptor or devices that accept data for transmission to a computer system (input), and accept data from a computer system for transmission to a user or process (output). Devices such as terminals that perform both functions are known as I/O devices.

LED – The acronym for light-emitting diode.

Line wraparound – Occurs when the end of a line is reached on a video screen; succeeding characters automatically start at the beginning of the next line.

LSI – The acronym for large scale integration.

Memory management – A unit that allows CPU access to memories of 64 K bytes or more, and provides protection and organization of memory areas.

Modem – 1) The acronym for modulator-demodulator. 2) A telecommunications device that provides the appropriate interface between a computer and a communications link.

MOS – The acronym for metallic oxide semiconductor.

MSCP – The acronym for mass storage control protocol.

Nonvolatile memory – A storage medium that retains its data in the absence of power.

ODT – The acronym for on-line debugging technique.

Oersted – A unit of magnetic field strength equal to the magnetic intensity one centimeter from a unit magnetic pole. Abbreviation: Oe.

Off-line – Pertaining to equipment, devices, and events that are not under direct control of a computer.

On-line – Pertaining to equipment, devices, and events that are under direct control of a computer. (Data is introduced into the CPU immediately.)

Parity bit – An extra bit added to a byte or word to ensure that there is always either an even or odd number of bits, according to the logic of the system.

Peripheral device – A device that is external to the CPU and main memory (e.g., a printer, modem, or terminal) but connected to them by appropriate electrical connections.

Processor status word – A register in some computers that indicates the current priority of the CPU, the condition of the previous operation, and other basic control items.

Program counter – A register in the CPU that holds the address of the next instruction (except in the case where the current instruction causes a jump).

PROM – 1) The acronym for programmable read-only memory. 2) A ROM that can be programmed by a user.

Protocol – A formal set of conventions governing the format and relative timing of message exchange between two communicating processes.

Quad module – An option for LSI-11 systems that requires four connectors on the backplane.

RAM – 1) The acronym for random-access memory. 2) A memory in which the CPU can access all locations with equal facility.

Random-access – Pertaining to a storage device from which data or blocks of data can be read in any order. (Therefore, in a random-access device, it is not necessary to read from the beginning to retrieve the desired data.)

Real-time – Pertaining to the actual time during which a process takes place.

Reserved instruction trap – A nonprogrammed conditional jump to a specified location that occurs upon the initiation of a reserved instruction.

ROM – 1) The acronym for read-only memory. 2) Preprogrammed memory that can be read from, but not written to.

Scrolling – The upward or downward movement of data on a video screen that allows new data to be displayed.

Subsystem – An organization of computer components (e.g., a tape drive and controller) that makes up a functional part of a larger system.

Trap – A conditional jump to a known memory location, performed automatically by hardware as a side effect of an instruction's execution. The address location from which the jump is made is stored. (A trap is distinguished from an interrupt, which is caused by an external event.)

Utility program – A program used to perform some frequently required process in the operation of a computer.

EK-OLCP5-TM-002