

DSD 210

DISKETTE MEMORY SYSTEM

GENERAL PRODUCT DESCRIPTION

Data Systems Design, Inc.
2241 Lundy Avenue
San Jose, CA 95131
(408) 946-5800
TWX 910-338-0249

Copyright © 1978

All rights reserved. No part of this manual may be reproduced in any form or by any means without prior written permission of Data Systems Design.

TABLE OF CONTENTS

	Page
I. General Information.	1
A. Scope.	1
B. Introduction.	2
1. Description of a Floppy Disk Memory System.	2
a. Diskette Description.	
b. Applications.	
C. General Description.	3
1. System Components.	3
a. Diskette Drive.	
b. Formatter/Controller (F/C).	
c. Computer Interface Modules.	
d. Front Panel.	
e. Back Panel.	
f. Power Supplies.	
g. Chassis.	
2. System Philosophy.	11
a. Sector Buffer.	
b. Register Transfers.	
c. Modularity.	
d. Handshaking.	
e. Error Philosophy.	
f. Expandability.	
g. Processor Independent Formatter/Controller.	
II. Installation.	14
A. Site Preparation.	14
1. Space.	14
2. Cabling.	14
3. AC Power.	14
B. Unpacking the System.	14
1. Physically Unpacking the Unit.	14
2. Inspection.	14
3. Rack Mount.	15

	Page
C. Jumper Options and Switch Options.	15
1. Formatter/Controller Board.	15
a. Logical Drive Number Assignment Switches	
b. Oscillator Jumper.	
2. PDP-8 Interface Board.	18
a. Device Code.	
3. PDP-11 Interface Board.	19
a. Peripheral Device Register Address.	
b. Interrupt Vector.	
c. Bootstrap.	
d. Bootstrap Disable.	
e. Bus Grant.	
f. NPR Disable.	
4. LSI-11, LSI-11/2 Interface Board.	22
a. Peripheral Device Register Address.	
b. Interrupt Vector.	
D. Installing Interface.	25
1. Install Cable.	25
2. Check Power.	26
3. Install Interface Board.	26
a. PDP-8.	
b. PDP-11.	
c. LSI-11, LSI-11/2.	
III. Operation.	28
A. Power Up.	28
B. Indicators and Switches.	28
1. Front Panel Switches.	28
a. Power Switch and Light.	
b. Write Protect Switches.	
2. Indicators.	29
a. Error Indicators.	
1. Data Error.	
2. Parity Error.	
3. Seek Error.	

	Page
4. Self-Test/Operator Error.	
b. Formatter/Controller Indicators.	
1. Init.	
2. Wait.	
3. Read.	
4. Write.	
c. Drive Select Lights.	
C. Diskettes.	32
1. Approved Vendors.	32
2. Handling.	32
3. Inserting into Unit.	33
4. Write Protecting.	34
D. Acceptance Testing.	34
E. Operating System Requirements.	34
1. PDP-8.	34
2. PDP-11 and LSI-11.	35
F. Bootstrapping.	35
1. PDP-8.	35
2. PDP-11.	36
3. LSI-11, LSI-11/2.	39
IV. Maintenance.	41
A. Philosophy.	41
B. Maintenance Features.	41
1. Self-Testing Routines.	41
2. Error Indicators.	42
3. Logical Drive Assignment Switches.	43
4. Controller Board Test Points.	44
5. Modularity.	44
6. Diagnostic Programs.	45
C. Diagnosing a Problem.	45
1. Indications on Power-Up and Initialization.	45
2. Checking the Diskettes.	46
3. AC and DC Fuses.	47
4. Checking the Power Supply Voltages.	48

	Page
5. Deassigning and Reassigning Logical Drives.	50
6. Isolating the Problem.	50
7. Diagnostic Programs.	50
D. Repairing the Unit.	50
1. Replacing the Formatter/Controller Board.	50
2. Replacing the Drive.	51
3. Replacing the Power Supply.	51
4. Replacing the Interface Board.	52

DSD 210 PRODUCT DESCRIPTION

I. General Information

A. Scope

This document describes the Data Systems Design DSD 210 Diskette Memory System. This random access mass storage subsystem (see Figure 1) is plug-compatible with the Digital Equipment Corporation RX11/RXV11/RX8E floppy disk system for PDP-11, LSI-11, LSI-11/2, and PDP-8 minicomputers. It is directly compatible with the DEC disk operating system software. Diskette media is freely interchangeable between the two systems.

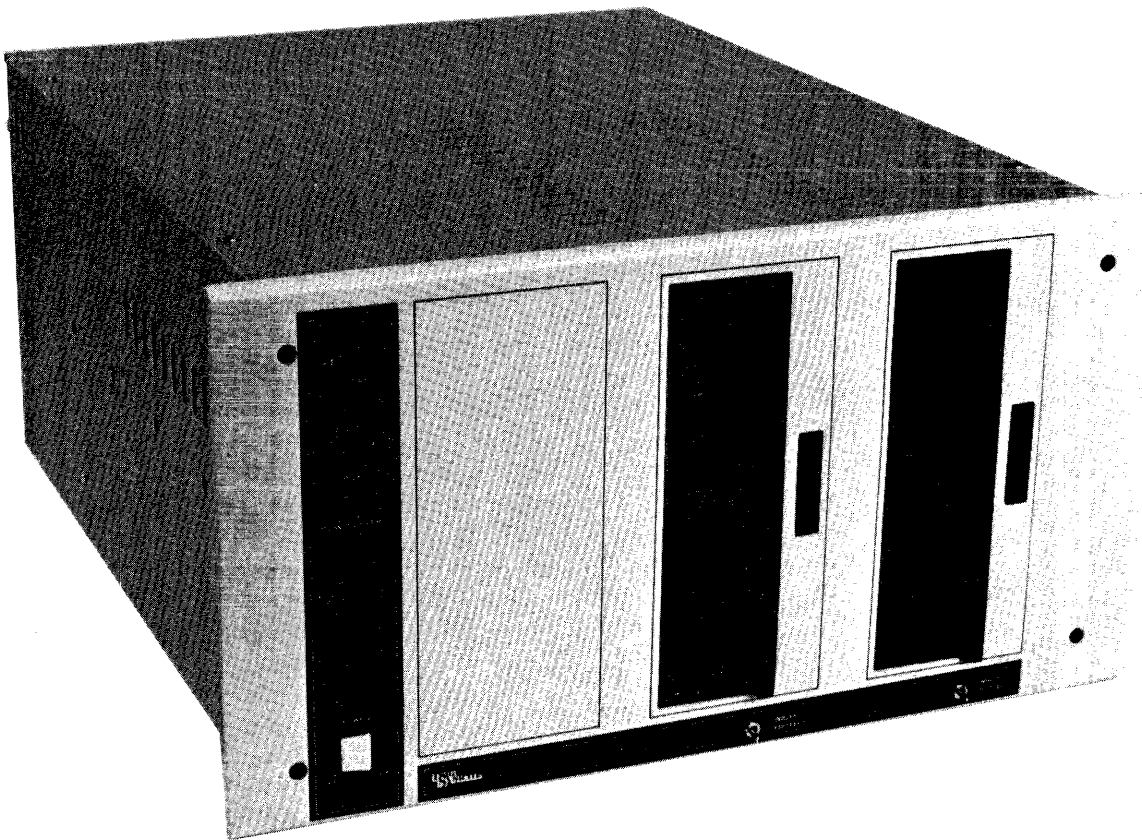

Fig. 1
DSD 210 DISKETTE MEMORY SYSTEM

B. Introduction

A Floppy Disk Memory System consists of a set of mechanical and electronic components arranged for the purpose of passing data between a host computer and a floppy disk, or as IBM calls it, a "diskette".

A floppy disk is an oxide-coated mylar disk, 7.8 inches in diameter and .005 inches thick. It is permanently housed in an 8 inch square flexible envelope. The floppy disk rotates inside the envelope at 360 RPM whenever the diskette is inserted into the drive and drive door is closed. In standard IBM single density format it can store up to 256,256 bytes of data which can be accessed randomly by the DSD 210 Floppy Disk Memory System.

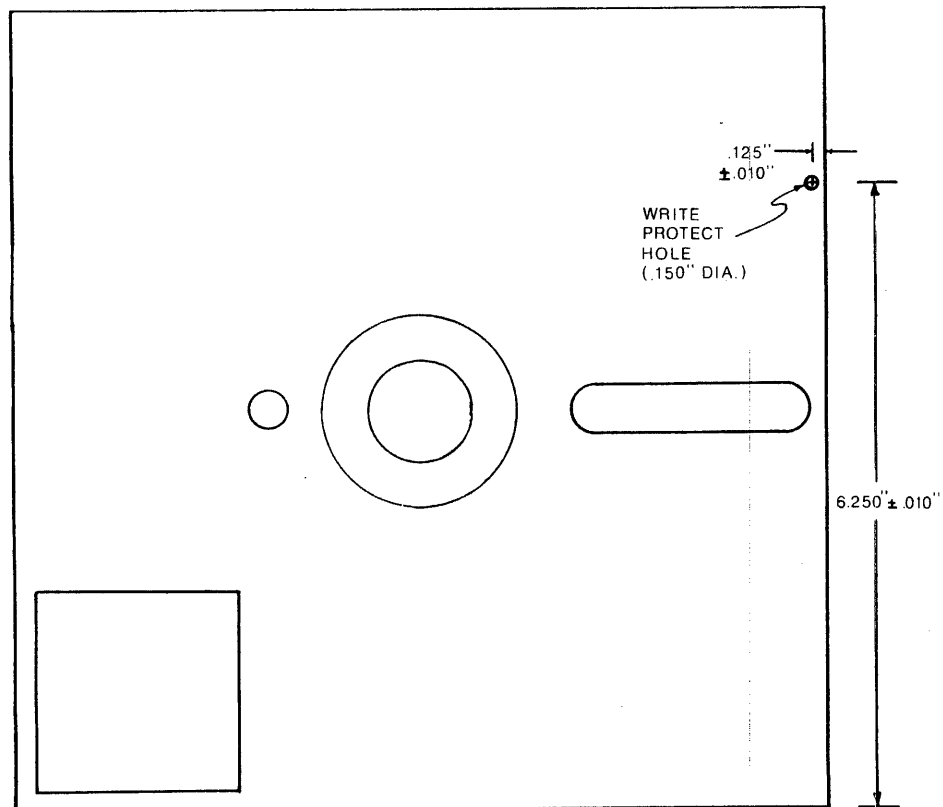

Fig. 2
Diskette

Floppy Disk Systems are ideal for applications that require a low cost, medium speed, random access memory device. Floppy disk systems provide faster access times than magnetic tapes, and cost less than the bigger rigid disk systems. They can replace paper tape or punch card storage methods. Because the diskettes can be quickly removed, the amount of data that is immediately accessible with a floppy disk system is far greater than the capacity of a single diskette. Diskettes can be exchanged in a drive within seconds, the limiting factor being the dexterity of the user.

Unlike the rigid disks, an industry standard exists for the physical format of the recorded data on diskettes. IBM 3740 format has been adopted by many floppy disk manufacturers. IBM format data is recorded on 77 tracks at a bit density of 3200 bits per inch on the inside track and a track density of 48 tracks per inch. Each track is divided into 26 sectors, each of which contains 128 bytes of data. Associated with each sector is an ID field and a data field. The ID field contains a unique bit pattern (ID Address Mark) that identifies it as an ID field. It also contains the track address and sector address of the sector. A CRC (cyclic redundancy check) word is appended to the ID field to insure that the ID field has been read correctly. At the beginning of the data field is a unique bit pattern (Data Address Mark) that identifies it as a data field. Following the Data Address Mark is 128 bytes of data followed by another CRC word for the data.

Because manufacturers have standardized on IBM format, diskettes can be readily exchanged between unlike computer systems.

C. General Description

1. Description of System Components.

The DSD 210 Floppy Disk Memory System is the product of careful design using quality components (thoroughly tested) to achieve a highly reliable, easily used and maintained minicomputer peripheral.

a. Diskette Drive.

The heart of the system is a reliable diskette drive. The DSD 210 is supplied with Shugart Associates diskette drives. These drives were chosen because they are the standard of the industry in both specifications and reliability. The diskette drive consists of read/write and control electronics, drive motor, read/write head, head positioning mechanism, and the removable diskette. These components perform the following functions: 1) Interpret and generate control signals. 2) Move the read/write head to the selected track. 3) Read or write data. In addition to these reliable drives, the DSD 210 utilizes a superior digital phase-lock loop circuit to separate data and clock signals as they come off the diskette. This circuit uses a crystal controlled 40 MHz clock for critical timing rather than using less reliable capacitor-controlled one-shots.

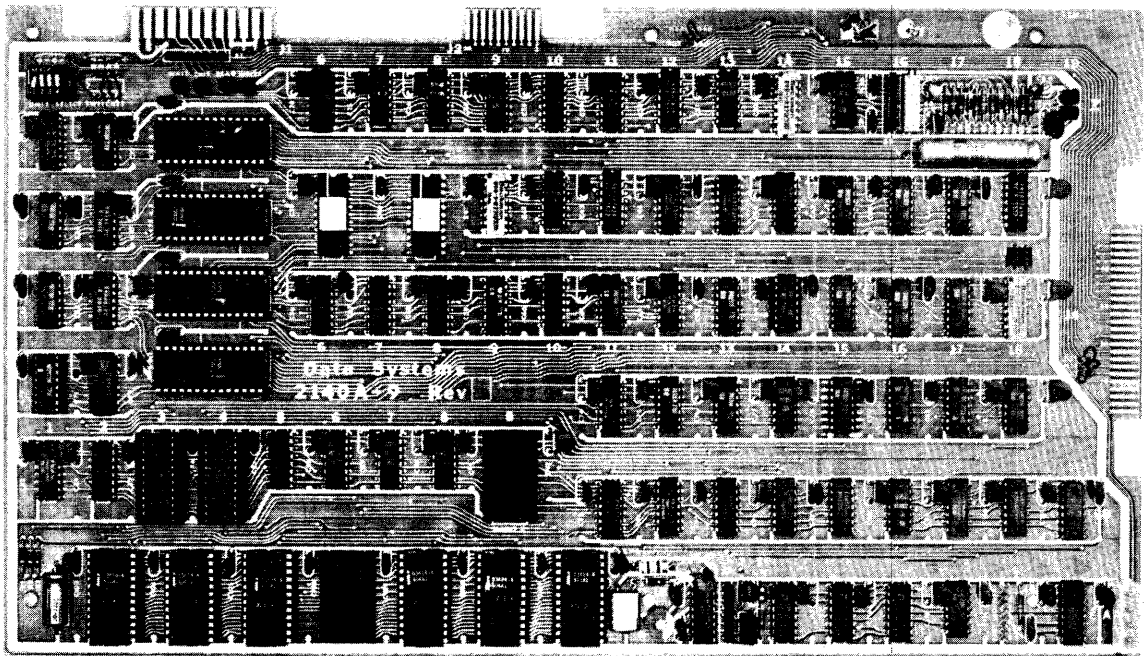

Fig. 3
Formatter/Controller Board

b. Formatter/Controller (F/C).

The intelligence of the system resides in the microcode of the F/C. The F/C accepts commands sent across the interface cable and controls the operation of the diskette drives. It causes the diskette drives to step to the proper track, it verifies that the read/write head is over the desired track and sector, and it reads or writes data while calculating and verifying the Cyclic Redundancy Check(CRC) word. When a command to access a sector on the diskette is issued, the F/C automatically loads the read/write heads of the selected diskette drive. When the operation has been completed, and another operation is not pending, the read/write heads are automatically unloaded within 43 milliseconds to give maximum media life. The F/C keeps track of the last track accessed, and supervises moving the read/write head to the next track and sector.

The F/C is capable of formatting diskettes in IBM 3740 format. This formatting capability allows the user to recover diskettes whose format has been altered. It also enables the user to select the sector interleaving pattern which maximizes his system throughput. Formatting does not allow the user to buy cheaper unformatted diskettes. High

quality certified diskettes are always sold with the IBM format already recorded on them.

The F/C executes self-test routines whenever the system is powered up or an INITIALIZE pulse is received from the host processor. If a self-test error should occur, the "Controller" LED on the front panel will alert the user to the error condition. In addition, a DC low circuit monitors the level of the 5 volts on the F/C board. If the 5 volts should drop below 4.8 volts the microprocessor systematically disables the system in order to avoid destroying the data on a diskette during power down. This same circuit senses when power has been applied to the unit. When the 5 volts on the F/C reaches 4.8 volts the system is initialized and the microprocessor executes a sequence of self-testing procedures to guarantee that the unit is operating correctly. If any faulty conditions are diagnosed, their presence will be reported on the error indicators on the front panel of the unit.

The heart of the F/C board is an eight bit microprocessor implemented with Intel 3002 bit-slice chips. The microprocessor utilizes a microprogram which resides in 1500 sixteen-bit words of PROM and a 256 byte RAM buffer capable of holding a full sector of data. This unique sector buffer relieves the host processor from the real-time constraints usually associated with rotating magnetic memory devices. The F/C receives its instructions and transfers data and status across a twenty wire flat cable. The other end of this cable is monitored by the host processor interface board.

c. Computer Interface Modules.

The minicomputer interface board links the F/C with the host processor. It accepts commands from the host processor, supplying the required handshaking, and passes these commands to the F/C, to which it also supplies the appropriate handshaking. The interface board acts as a go-between for data as it passes between the processor and the F/C. The interface board signals the processor when a response is required or when an operation has been completed.

The standardization of the protocol associated with the signals on the Interface-to-F/C cable makes it feasible for the DSD 210 Floppy Disk Memory System to be easily adapted to

other minicomputer or microprocessor systems. As of this writing, four different interface modules were available for the DSD 210. These modules are for the PDP-11, LSI-11, PDP-8 and the PCM-12.

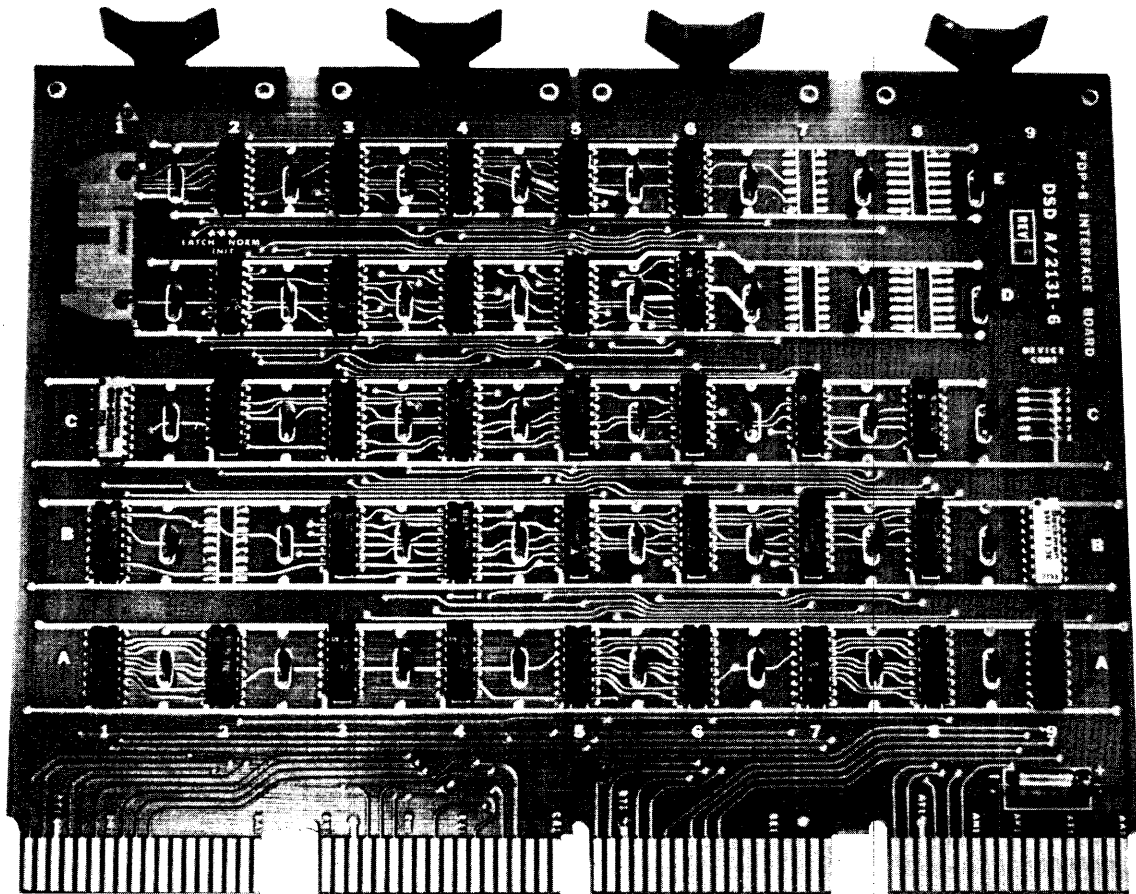

Fig. 4
PDP-8 Interface Board

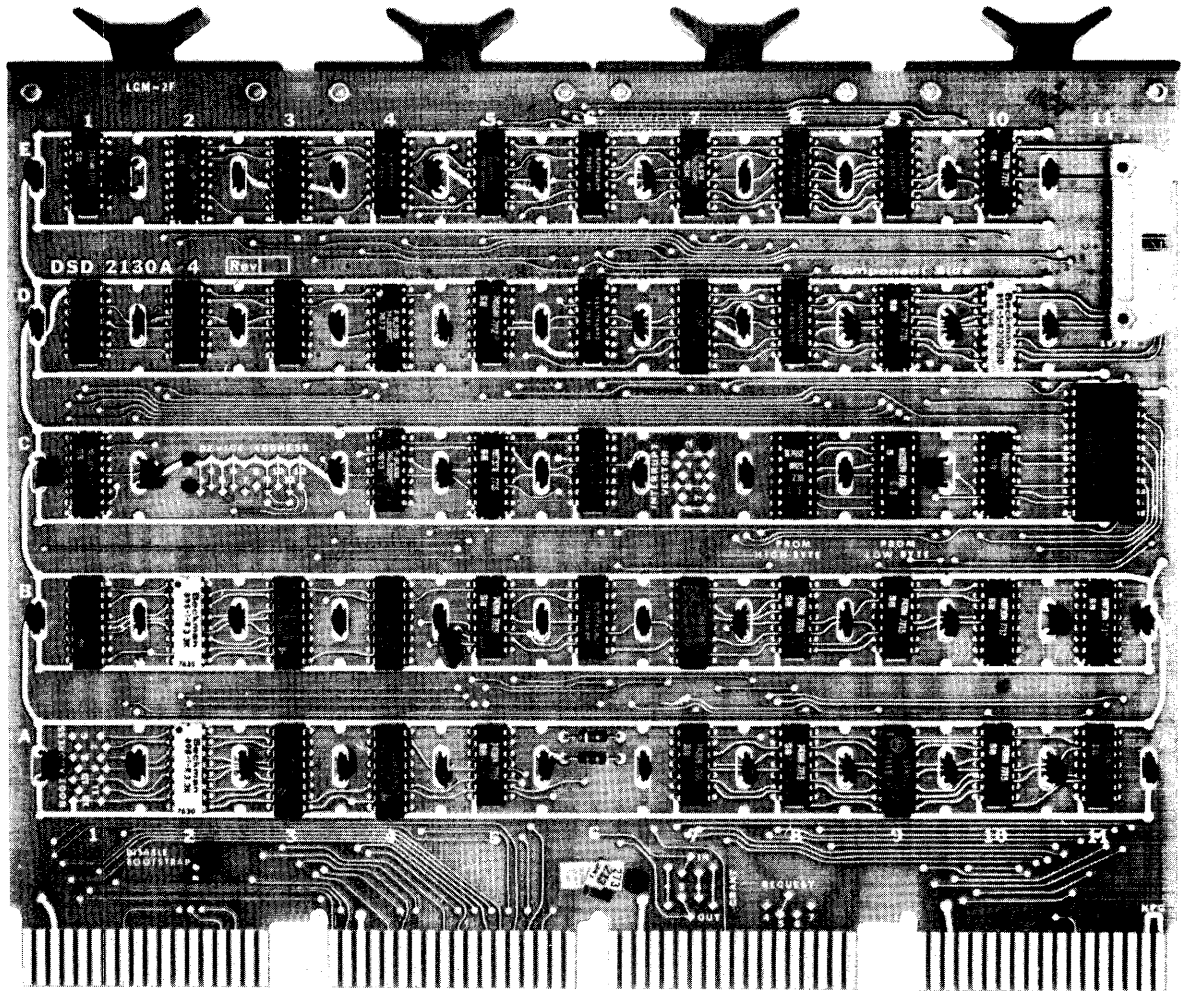

Fig. 5
PDP-11 Interface Board

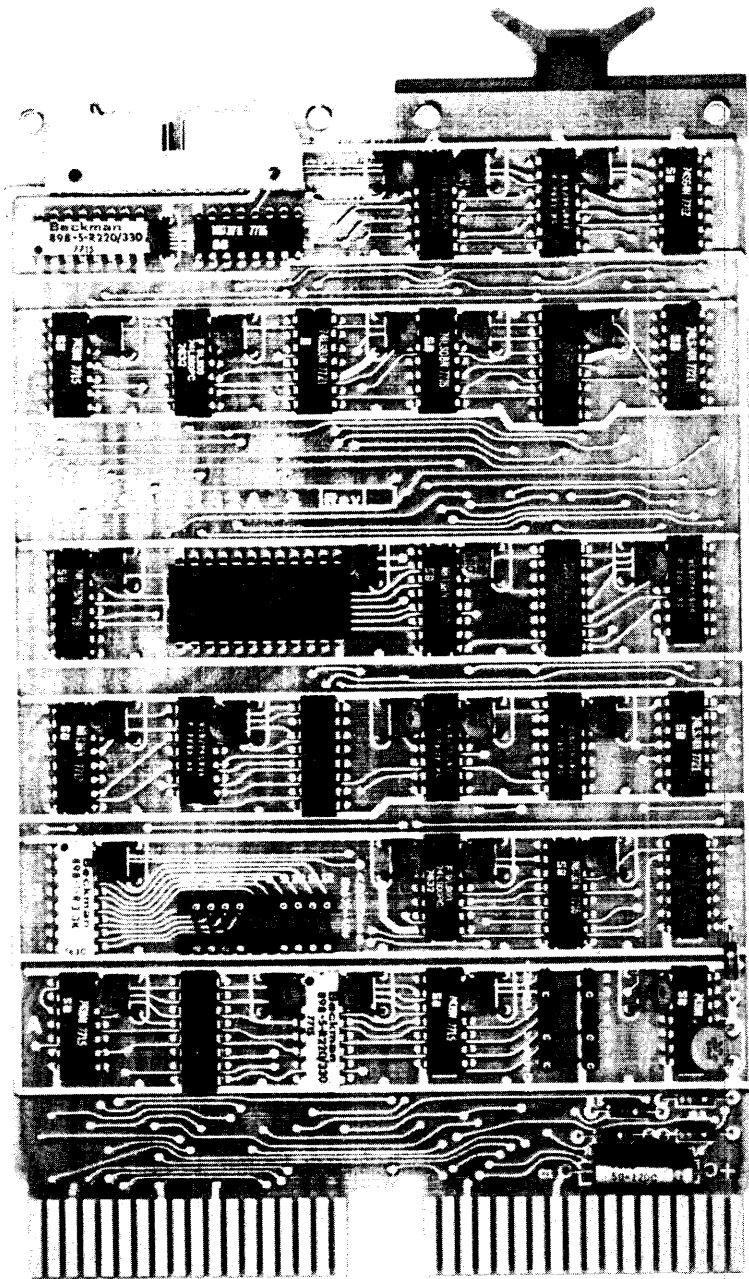

Fig. 6
LSI-11 Interface Board.

d. Front panel.

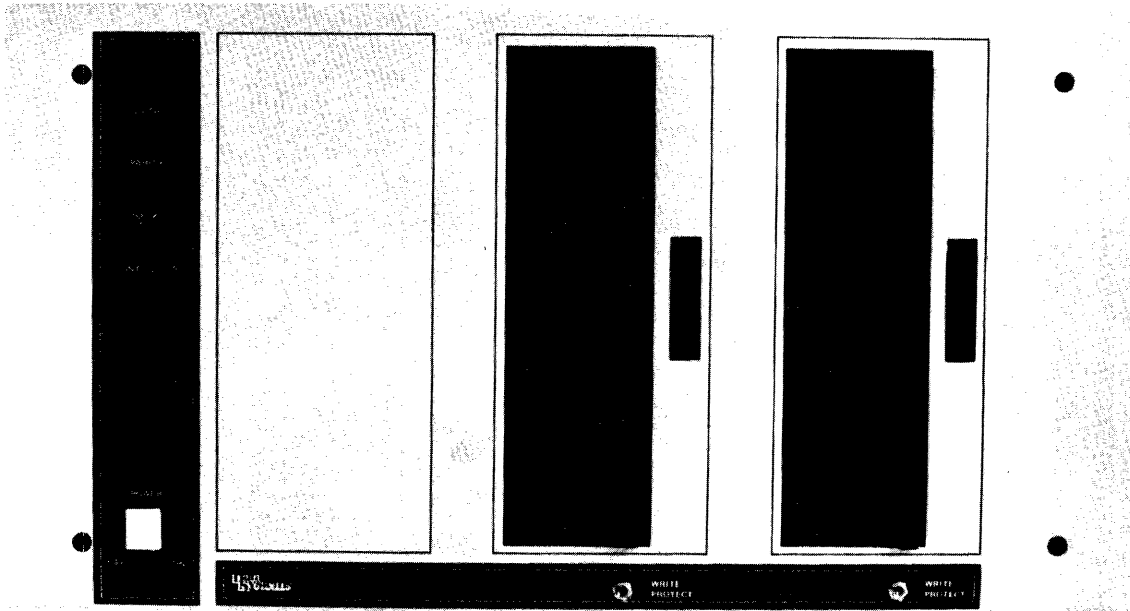

Fig. 7
Front Panel

The front panel of the DSD 210 was designed to make the system easy to use while giving the user visual feed-back when an unusual situation occurs. Lights on the vertical panel indicate when an access has failed due to faulty media, hardware failure, or operator error. When the system is powered up, or when an INITIALIZE pulse is received from the host processor, but before any data transfers occur, the microprocessor on the Controller/Formatter executes a series of self-testing routines. If any of these routines fail to execute properly, one of the error lights will illuminate. This feature diagnoses problems before they can modify or destroy valuable data or programs on diskettes. When an error does occur, the lights aid in determining the cause of that error.

These lights can also be illuminated any time during an operation involving the DSD 210. See section III-B-2 for more details about the error indicators.

There are two other types of lights on the front panel. The diskette drive activity LED's, and the light housed in the power switch.

The diskette drive activity light is mounted on the diskette drive in the rectangular diskette eject button which is at the right of the opening through which diskettes are inserted into the drive. This light indicates that an operation is in progress and that the diskette should not be removed until the light is extinguished.

The AC Power switch applies power to the DC power supplies and to the drives. The light within the switch is powered by the 5 volt power supply. This light notifies the user that the unit is plugged into an active AC outlet and that the 5 volt supply is operational.

There is also another type of switch on the front panel. Write Protect Switches are mounted beneath each drive. When a Write Protect Switch is on, nothing can be written on the diskette which is in the associated drive. Diskettes with a Write Protect hole in their jackets can also be Write Protected by exposing the hole. Diskettes can only be written upon when the diskette either does not have the Write Protect hole, or the hole is covered, and the Write Protect Switch is in the "off" position.

e. Back Panel.

The back panel serves as a mounting plate for the power supplies, the power distribution panel, the fan, and the fuses. Five screws allow removal of the back panel without disturbing any other modules or functions of the system. When these screws are removed, the panel will lie flat on a surface behind the unit without stressing any of the cables or wires leading to it. This configuration allows easy access to all the components that are mounted on the back panel for testing and maintenance purposes while the unit is operating.

All connections between the components in the DSD 210 and the back panel are made with connectors. This method allows for easy removal and replacement of any module without any need to cut or unsolder any connections. All connectors are keyed to prevent misconnection.

Leading out of the unit through the back panel is the signal cable and the AC Power cord. The signal cable is 10 feet long and the AC cord is 9 feet long.

f. Power supplies.

Mounted on the back panel are three power supplies:

+5 Volts

+24 Volts

-10 Volts

The +5 Volt supply powers the Formatter/Controller board and the diskette drives. The +24 Volt supply powers the diskette drive. The diskette drive also uses -10 Volts and AC. These supplies are open frame OEM type purchased from reliable suppliers. The supplies have overcurrent protection and crowbar overvoltage protection for maximum safety.

g. Chassis.

The Chassis is a standard 17 inch wide, 22½ inch deep, and 10½ inch high rack mountable unit which can accommodate from one to three vertically mounted Shugart drives. The cover of the Chassis is attached with four quarter-turn fasteners. The F/C module is mounted vertically on the left hand wall of the chassis with Ritchco Fasteners for easy removal and installation. The drives are mounted in the chassis with three easy access screws for quick removal and replacement. The removal of any component in the chassis does not require the removal of any other component. A fan is mounted on the back panel for cooling the components. Slots are strategically placed in the chassis to route the air flow to the necessary areas. Foam tape is used to block unwanted air flow passages.

For rack mounting, the side panels are supplied with captive fasteners for mounting Chassis-Trak or Zero Corp. chassis slides. The slides can be mounted without removing any of the system's covers.

2. System Philosophy

a. Sector Buffer.

The DSD 210 contains a SECTOR BUFFER RAM on the F/C board which holds 128 bytes of data. In order to write data on a diskette, the SECTOR BUFFER RAM must be loaded from memory using a "Fill Buffer" operation. After the SECTOR BUFFER RAM has been loaded with the appropriate data, a "Write Sector" command is executed. During the "Write Sector" operation, the desired track and sector numbers are passed to the F/C. When the drive read/write head is over the desired sector, the data in the SECTOR BUFFER RAM is automatically written onto the diskette in IBM format.

In order to read data from a diskette, a "Read Sector" operation is executed. During a "Read Sector" operation, the desired sector and track numbers are passed to the F/C and the contents of that sector is read into the SECTOR BUFFER RAM. An "Empty Buffer" operation is then executed to pass the data from the SECTOR BUFFER RAM to memory. The sector buffer can be used to facilitate fast copying of data from one diskette to another. A sector can be read into the SECTOR BUFFER RAM and then written onto another sector on a diskette without transferring data to main memory. The SECTOR BUFFER RAM could also be used for temporary storage by the processor. A 128 byte data block could be stored in the SECTOR BUFFER RAM using the "Fill Buffer" operation and then later retrieved using the "Empty Buffer" operation.

The "Write Sector" and "Empty Buffer" operations do not modify the contents of the SECTOR BUFFER RAM. See the section on programming for more details on how to program the system.

b. Register transfer.

In order for the DSD 210 to be DEC instruction set compatible, Programmed I/O or Register Transfer I/O is used to transfer instructions and data between the processor and the DSD 210 interface card.

In the case of the PDP-8, IOT's are used to transfer data and instructions. In the case of the PDP-11 and the LSI-11, Peripheral Device Registers are used. The advantage of programmed I/O is that the programmer always has control of when data will be transferred. In real time environments, the programmer has no control of when data will be transferred after a DMA operation has been initiated. The cycle stealing aspect of a DMA interface might become a problem while the register transfer type of I/O gives the programmer complete control of data transfer operations.

c. Modularity.

The DSD 210 Floppy Disk Memory System was designed in a modular architecture to minimize the effort required to diagnose faults and to subsequently repair them. Four main modules comprise the set of components most likely to need attention. They are:

Diskette Drives

Formatter/Controller

Power Supply

Interface

Error Lights and status registers are the keys to pin-pointing the cause of an error. If the error is due to a hardware malfunction, the faulty module can be easily identified and replaced using only a blade screw driver and an allen wrench.

d. Expandability

The DSD 210 can be upgraded by adding diskette drives. A single drive system can be factory upgraded to a dual drive system and a dual drive system can be factory upgraded to a triple. In each case a new front panel must be provided and the additional cables to connect the added drive must be provided.

Data Systems Design does not encourage upgrading, but will upgrade a system when necessary. It is preferable that the customer thoroughly evaluate his storage requirements before he buys in order to eliminate the necessity for upgrading at a later date.

In order for a system to have more than three drives, two DSD 210's are required. Device codes, register addresses, and vector addresses are wire wrap jumperable on the interface boards to facilitate easy modification of one of the boards to assign different addresses to the additional interfaced.

e. Processor Independent Formatter/Controller (F/C).

The DSD 210 Floppy Disk System was designed to interface to the PDP-8, PDP-11, and LSI-11 processors. The only differences between these three systems are the interface modules. The F/C and everything else in the chassis remains unchanged. This transferability suggests that any mini/micro could be interfaced to the DSD 210. The cable between the F/C and the interface is implemented in a 20 wire flat cable, of which 9 wires are signals and 11 are ground. The 9 signals are:

- INIT
- DATA
- SHIFT
- TRANSFER REQUEST
- ERROR
- DONE
- 8/12 BIT MODE
- BC READY
- OUT

II. Installation

A. Site Preparation.

1. Space.

The DSD 210 is approximately 19 inches wide, 10½ inches high and 22 inches deep, and is designed to fit into a standard EIA 19 inch rack. The sides of the cabinet are fitted with captive nuts for mounting chassis slides. Zero Corp. or Chassis Trak slides will fit onto these mountings. There must be several inches of air space immediately behind the cabinet. DO NOT block the top vents of the unit with papers, books, or other items that could restrict air flow.

2. Cabling.

The AC power cable extends approximately 8 feet beyond the DSD 210 back panel.

The 20-conductor signal cable (ribbon cable) can be extended 9 feet beyond the DSD 210 back panel; the user must make cable length allowances for routing this cable to the interface board inside his computer.

3. AC Power.

AC power requirements for DSD 210 systems at 110V 60Hz are as follows:

<u>Model</u>	<u>AC Current</u>
DSD 210-X-1	1.5 amperes
DSD 210-X-2	2.0 amperes
DSD 210-X-3	2.75 amperes

B. Unpacking the System.

1. Physically Unpacking the Unit.

Save all packing material. Place the shipping carton on a strong steady surface. Make sure that the box is oriented with the proper side up. Open the appropriate end of the carton. Remove and save all materials (documentation, diskettes, interfaces, etc.) that are found inside the outer carton. Open the inner carton. Remove the corrugated packing pieces. Slide the DSD 210 out of its "floater" carton. Remove the corrugated side pieces from the DSD 210. Remove the foam rubber jaw restrainers from the doors of the Shugart drives.

2. Inspection.

Inspect the DSD 210 and all of its accessories for shipping damage. Remove the top of the DSD 210 and inspect all connectors and IC's to be sure that they are all properly seated. If any part is damaged, immediately notify Data Systems Design.

3. Rack Mount.

(For rack mounted systems only.) Attach the inside tracks of the chassis slides to the DSD 210, using the 10-32 machine screws that are provided with the chassis slides. Locate the proper holes in the rack and attach the outer tracks to the rack cabinet. Place the tracks of the DSD 210 into the tracks that are bolted to the cabinet and slide the unit into the cabinet until the slides lock in their "extended" position. Disengage the locking buttons on the left and right chassis slides simultaneously and push the DSD 210 the rest of the way into the rack.

C. Jumpers and Switch Options.

1. 2140 (Controller/Formatter) Board

a. Logical unit/physical unit mapping switches.

The user is allowed to map logical (software) disk drives into physical (hardware) disk drives. This capability allows the user to reconfigure his system in the event of a drive malfunction. For example, if the user's software maintains logical unit 0 as its system diskette, and the drive that normally responds to "logical unit 0" is broken, the user can reset the mapping switches so that a different unit responds to a command for logical disk 0.

Logical unit codes for nonexistent drives should be set to "3" (both jumpers present or both switches closed). A system must contain a logical unit 0 or a seek error will occur during system initialization. Sequential logical unit numbers should be used.

b. Oscillator Jumper.

(Remove for factory testing only.) This jumper connects the crystal oscillator clock to the rest of the controller. It must be present for the system to operate properly.

Logical Drive units in DSD 210 systems are arranged as follows:

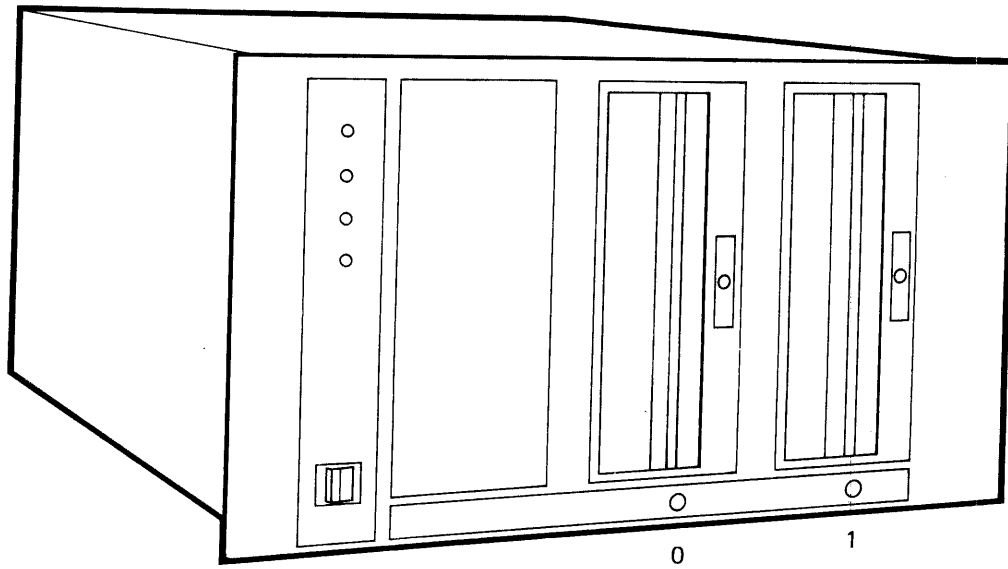

Fig. 8
Logical Drive Number Assignments

Unit Select (mapping) switches or jumpers are arranged as follows:

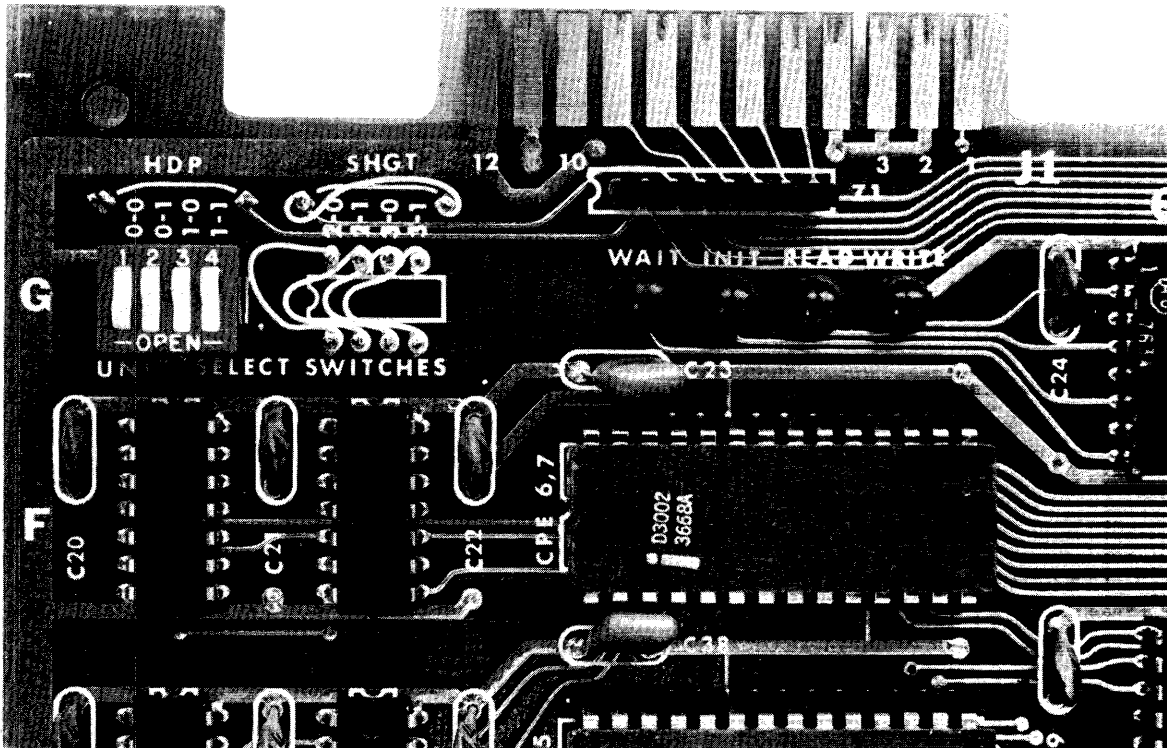

Fig. 9
Physical Unit Number Assignment Switches

The position of each pair of jumpers or switches represents a binary code of the logical unit number that the associated physical drive will respond to. The numbers above the switches and jumpers are in the form of X-Y, where X represents the physical drive number, and Y represents the bit position; 1 being the LSB and 2 being the MSB. A jumper in place or a switch in the closed position represents a "1"; position represents a "0".

2. 2131 (PDP-8) Interface Board.

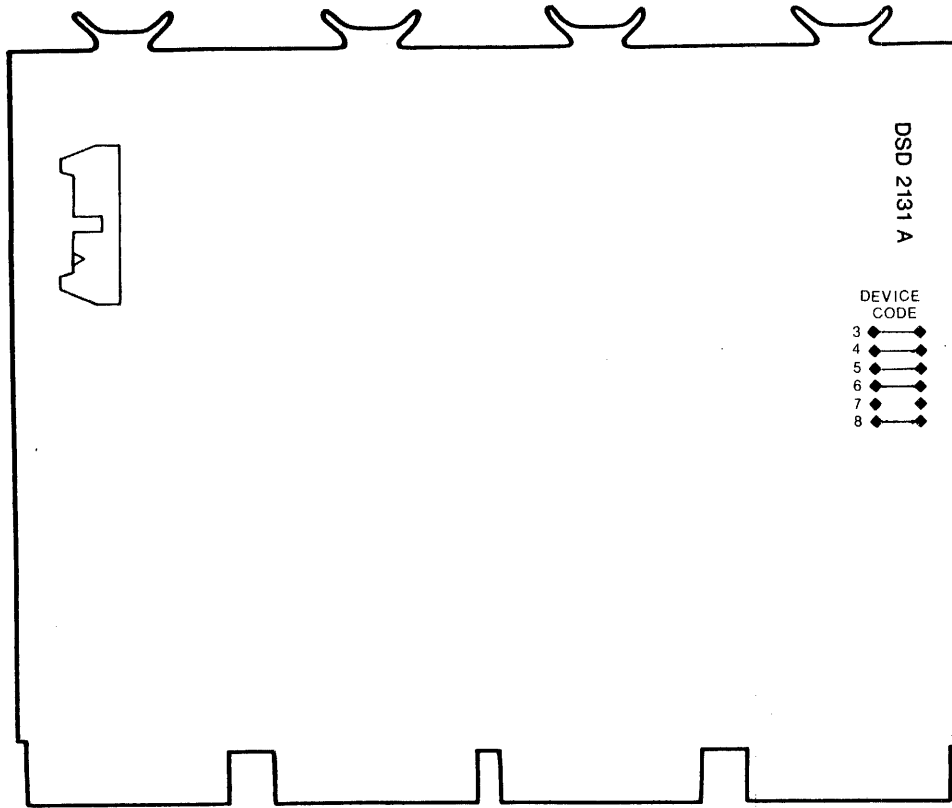

Fig. 10
Jumpers on PDP-8 Interface Board

a. Device Code.

JUMPER PURPOSE: Device Code
 POLARITY: Jumper present = logic 1 in device code
 RANGE: X00X to X77X
 NORMAL CONNECTION: (Device Code = 675X)

<u>JUMPER</u>	<u>STATE</u>
3	present
4	present
5	present
6	present
7	present
8	present

3. 2130 (PDP-11) Interface Board

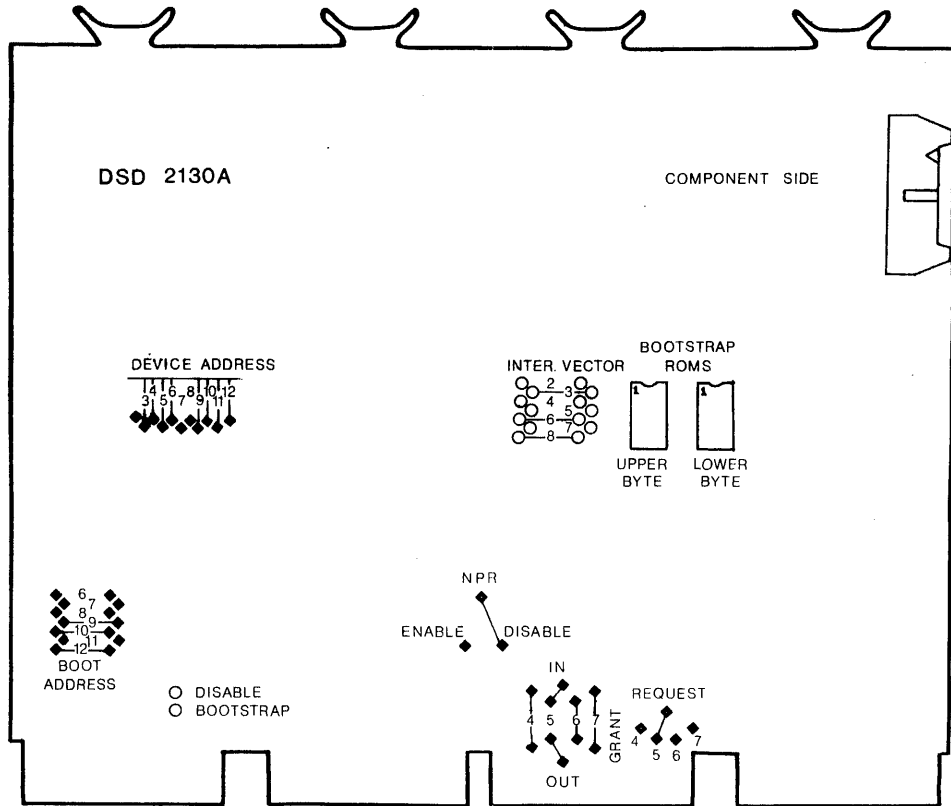

Fig. 11
PDP-11 Interface Board
SPC Bus Grant Continuity

a. Peripheral Device Register Address.

JUMPER PURPOSE: Device Address
POLARITY: Jumper present = logic 1 in device address
RANGE: 760000 to 777774
NORMAL CONNECTION: (Device Address = 17717X)

<u>JUMPER</u>	<u>STATE</u>
2	missing
3	present
4	present
5	present
6	present
7	missing
8	missing
9	present
10	present
11	present
12	present

b. Interrupt Vector.

JUMPER PURPOSE: Interrupt Vector
POLARITY: Jumper present = logic 0 in vector
RANGE: 000 to 774
NORMAL CONNECTION: (Interrupt Vector = 264)

<u>JUMPER</u>	<u>STATE</u>
2	missing
3	present
4	missing
5	missing
6	present
7	missing
8	present

c. Bootstrap.

JUMPER PURPOSE: Bootstrap Base Address
POLARITY: Jumper Present = logic 1 in base address
RANGE: 7600XX to 7777XX
NORMAL CONNECTION: (Base Address = 1730XX)

<u>JUMPER</u>	<u>STATE</u>
6	missing
7	missing
8	missing
9	present
10	present
11	missing
12	present

d. Bootstrap Disable

JUMPER PURPOSE: Disable Bootstrap (used in PDP-11/04 systems where the bootstrap code overlaps the front panel emulator code.)
POLARITY: Jumper present = disable bootstrap
NORMAL CONNECTION: Jumper missing

e. Bus Request and Bus Grant Jumpers

JUMPER PURPOSE: Interrupt level control
NORMAL CONNECTION: LEVEL 5

The DSD 210-11 is capable of supplying interrupts on levels 4, 5, 6, or 7. Jumper options allow the user to select any interrupt level that he desires.

There are two sets of jumpers that the user must contend with. First, the user should connect the interrupt request line ("REQUEST") to the appropriate bus request line ("4, 5, 6, 7"). REQUEST can only be connected to one line at a time so the user must cut the trace connecting REQUEST to "5" before he can insert his jumper to some other level. Second, the user must connect the BUS GRANT logic to the appropriate BUS GRANT level. The line labelled IN should be connected to the nearest pad labelled with the number of the priority level that the user wishes to use. OUT should be connected to the other pad with the same number. All of the other priority level pads should be jumpered together (do not connect together the two pads of the priority level that you wish to use). The REQUEST and GRANT levels must be identical.

f. NPR Disable.

JUMPER PURPOSE: NPR speed-up circuit control
POLARITY: ENABLE JUMPER enables speed-up circuit
NORMAL CONNECTION: DISABLE (do not change this)

4. 2132 (LSI-11, LSI-11/2) Interface Board,

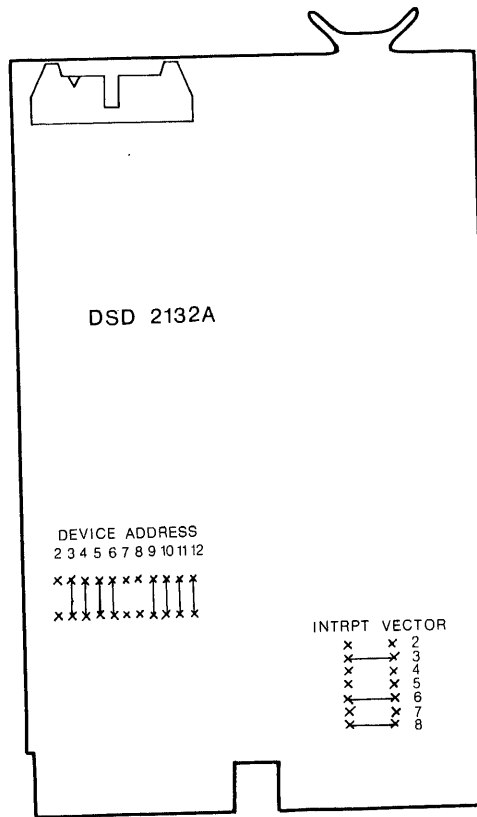

Fig. 12
LSI-11 Interface Board

a. Peripheral Device Register Address.

JUMPER PURPOSE: Device Address
POLARITY: Jumper Present = logic 1 in device address
RANGE: 160000 to 177774
NORMAL CONNECTION: (Device Address = 17717x)

<u>JUMPER</u>	<u>STATE</u>
2	missing
3	present
4	present
5	present
6	present
7	missing
8	missing
9	present
10	present
11	present
12	present

b. Interrupt Vector.

JUMPER PURPOSE: Interrupt Vector
POLARITY: Jumper present = logic 0 in interrupt vector
RANGE: 0000 to 1774
NORMAL CONNECTION: (Interrupt Vector = 264)

<u>JUMPER</u>	<u>STATE</u>
2	missing
3	present
4	missing
5	missing
6	present
7	missing
8	present
9	present

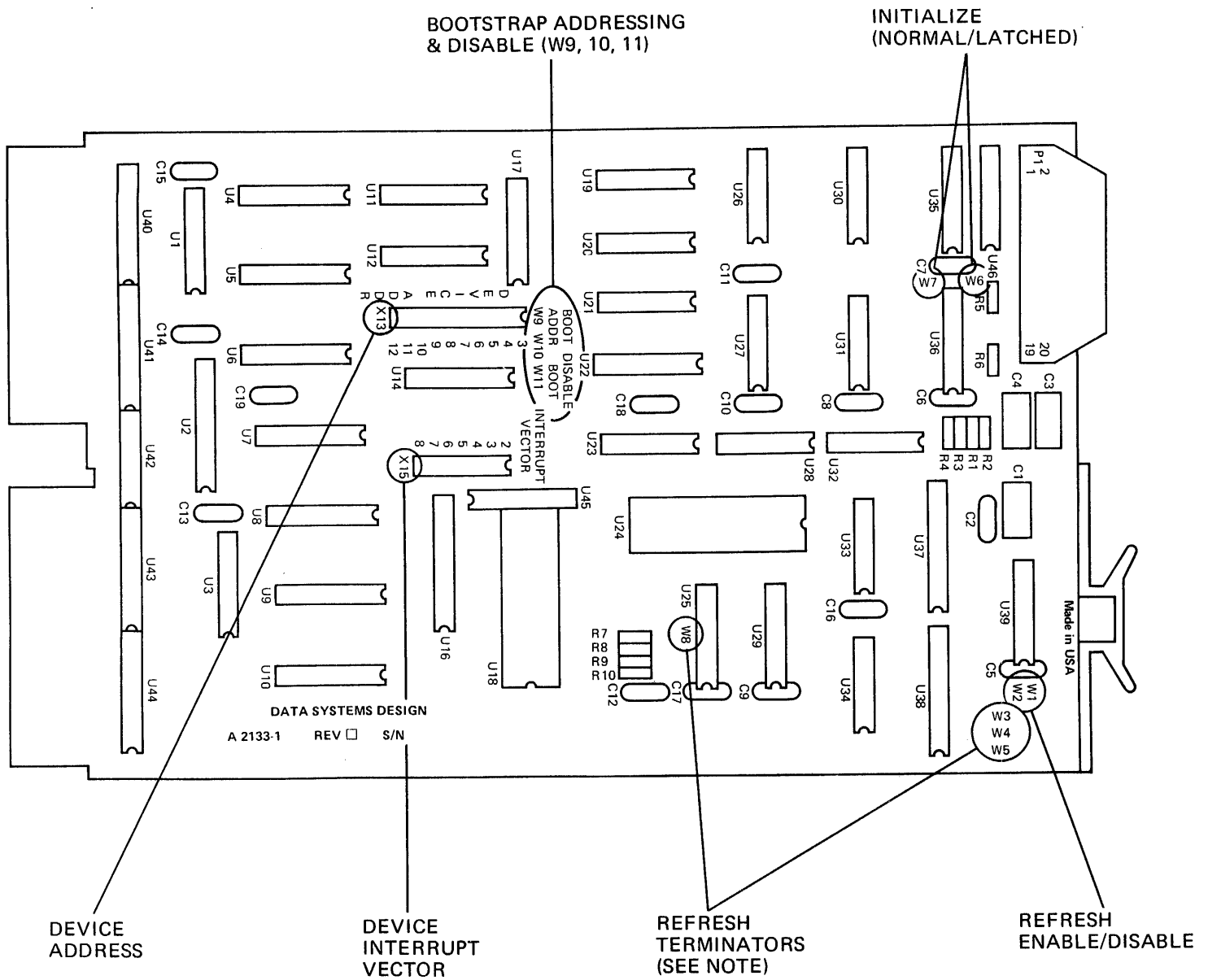

REFRESH		BOOTSTRAP		
W1:	REFRESH ENABLE	W9	W10	ADDRESS
W2:	REFRESH DISABLE	0	0	173000
W3,4,5,&8:	REFRESH TERMINATORS— FOR USE WHEN REFRESH LOGIC IS NOT INSTALLED.	0	1	171000
		1	0	167000
		1	1	165000
INITIALIZE		W11: BOOTSTRAP DISABLE		
W6:	NORMAL INITIALIZE			
W7:	LATCHED INITIALIZE			

DEVICE ADDRESS AND VECTORING
 DEVICE ADDRESS JUMPER INSTALLED : LOGIC 1
 INTERRUPT VECTOR JUMPER INSTALLED : LOGIC 0

DSD 210-L11A BOOTABLE INTERFACE MODIFICATION INSTRUCTIONS

D. Installing Interface

1. Install Cable.

Remove the tape holding the signal cable to the back panel of the DSD 210 and route the cable into the host processor. Plug the socket connector on the end of the cable into the 20-pin header on the computer interface board. Be sure to observe the polarities as indicated in figure 13.

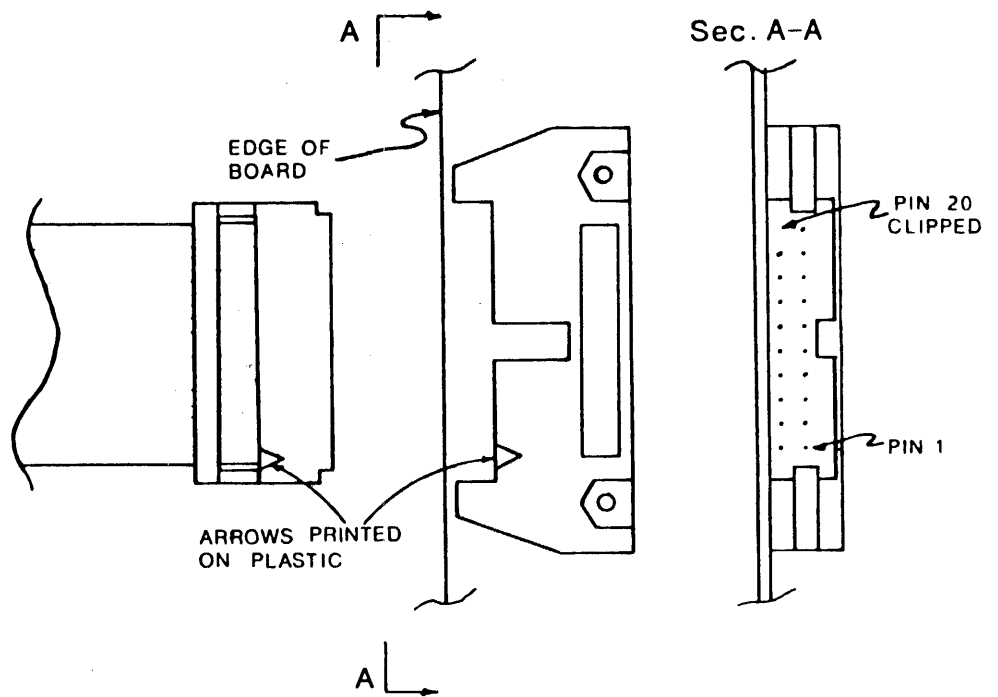

Fig. 13
Interface Cable and PC Header

2. Check Power.

Be sure that all power is off in the processor.

3. Install Interface Board.

a. 2131 (PDP-8) Interface Board.

Plug the 2131 (PDP-8) board into an Omnibus slot. Be sure IC's on the 2131 board face in the same direction as IC's on the other boards in the PDP-8. Also check to insure that components on adjacent boards do not contact the 2131 board.

b. 2130 (PDP-11) Interface Board.

The 2130 board plugs into a Small Peripheral Controller (SPC) slot in the PDP-11. Unused SPC slots can be identified by the presence of a "Bus Grant Continuity Card" in one of the four card edge connection positions. The Bus Grant Continuity Card is a 2 inch square card that passes signals through unused SPC slots. Select an unused SPC, keeping in mind that the position of a peripheral on the Unibus determines what priority within its bus request level that peripheral will receive. Plug the 2130 board into the SPC slot. Be sure IC's on the 2130 board face in the same direction as IC's on the other boards in the PDP-11. Also check to insure that components on adjacent boards do not contact the 2130 board.

c. 2132 (LSI-11) Interface Board.

The 2132 board plugs into a Device Slot on the LSI-11 bus. Keeping in mind that the device closest to the processor is assigned the highest priority, select a device slot and plug in the 2132 board. Be sure IC's in the 2132 board face in the same direction as IC's on the other boards in the LSI-11. Also check to insure that components on adjacent boards do not contact the 2132 board.

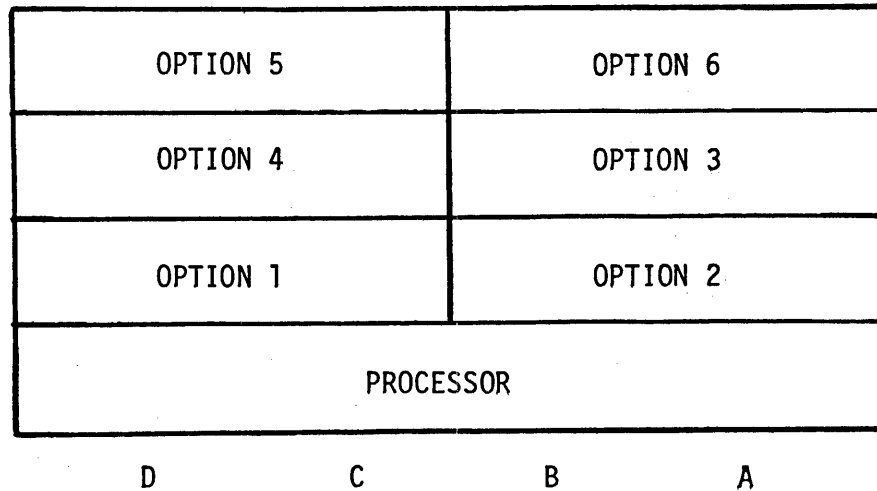

Fig. 14
LSI-11 Device Slots

III. Operation

A. Power Up.

Plug in the AC power cord and switch the power switch on the front panel of the DSD 210 to the on position. The pilot light in the switch should go on, and the system should initialize. Initialization consists of lighting the INIT LED on the 2140 Formatter/Controller board, executing 0.5 seconds of self-testing microcode and initializing the diskette drives. Each drive head should move ten tracks into the center of the diskette and then back out until track 00 is found. If all of this is successfully accomplished, the WAIT LED on the Formatter/Controller board will go on and no error lights will be illuminated.

B. Indicators and Switches

1. Front Panel Switches

a. Power Switch and Light (replacing lamp)

The power switch is a lighted rocker switch. When this switch is "on", power is applied to the DC power supplies which provide power to the controller board. The 5VDC for the lamp in the power switch is supplied from the controller board; hence the light in the power switch indicates that power is actually being provided to the controller board and the rest of the system.

The lamp is a 6 volt, .2 ampere T-1 3/4 miniature screw base lamp (Chicago Miniature Lamp number 1768). If this lamp should need replacing, unplug the system power and remove the rocker in the switch assembly (grip the rocker with a pair of serrated-jaw long-nosed pliers and snap the rocker out with a sharp motion). Using a lamp remover tool or a piece of .22 I.D. plastic tubing, grip the bulb and unscrew it. Replace the bulb with an equivalent one, and snap the bezel back into place.

b. Write Protect Switches.

The write protect switches are used to prevent the DSD 210 system from writing over important data. If the host computer should attempt to write on or reformat a diskette in a write protected drive, an error will be reported to the host and no writing will take place. Note that the action of write-protecting one drive will have no effect on attempts to write on a different drive.

2. Indicators.

There are eight LED indicators in a DSD 210 system, four error indicators located on the front panel and four status indicators located on the 2140 Formatter/Controller board. In addition to the error and status indicators, each disk drive has a DRIVE SELECTED LED.

a. Error Indicators.

1. Data Error.

A data error occurs when disk data is not present or is unrecognizable, when data is read but is found to contain an erroneous Cyclic Redundancy Check (CRC) code, or (during a format operation only) when no index hole is found on the diskette.

The most common cause of DATA errors is the attempt to do a disk operation on a drive that contains no diskette. The controller looks for data and, upon finding none, executes an error return.

Dirty, worn, or miswritten diskettes are the next most likely cause of DATA errors. Magnetic dirt can affect the read or write signal strength causing dropped bits or extraneous bits in the disk data stream; for practical purposes all of these types of errors are detected by the controller CRC logic.

The head alignment on a floppy disk drive is seldom a problem, but if the head is skewed or not aligned on track, signal strength or media interchangeability problems will arise. The most common symptom of misalignment is a CRC error (data error).

Format operations are unique among disk operations in that they do no reading at all. A format operation consists of writing an entire track of data, from index mark to index mark. If no index marks are found, a DATA error is indicated.

2. Parity Error.

Communication between the computer interface board and the 2140 controller is accomplished using a single bi-directional data line; data transfers are serial in nature. The computer interface boards append a parity bit onto the end of each transmission. The 2140 controller checks the parity on each command that it receives and verifies the interface cable integrity. If a parity error is detected, the command is aborted and the parity error indication is given.

3. Seek Error

Seek errors arise when a non-existent track or logical unit is selected, when a drive improperly "homes" (track 00) during an initialize, and when the track byte of the header read from a diskette does not match the expected value.

By far the most common cause of this type of errors are improperly set unit select mapping jumpers. For example, setting the unit select switches so that there is no logical drive 0 or so that logical drive 0 maps to a non-existent physical drive will result in an error.

Seek errors can also be caused by a misaligned head. This results when a head is stepped out to what should be track 00 but what actually is another track. This type of malfunction usually manifests itself in DATA errors, and in diskette interchangeability problems.

4. Controller Errors.

Two distinct types of problems can cause this indicator to be lighted: either the 2140 controller detected an error in its own operations or the controller detected a switch violation.

Every time the controller is initialized, it executes .5 of extensive self-test microcode. If the controller detects a malfunction, it responds by lighting the CONTROLLER light, setting the done and error flags to the computer interface, and refusing to accept new commands.

Whenever a write or format operation is requested the write protect switch for the selected drive is consulted. In addition, the write protect hole in the diskette is checked to see that it is covered. If a write protect fault is found, the CONTROLLER ERROR LED is lighted.

b. Controller/Formatter Indicators.

1. Init.

The INIT LED indicates that a system initialization has occurred (from a power down/up cycle, or INIT command, or a CLEAR or INIT pulse on the host computer bus). This led remains on until a new operation command is received.

2. Wait.

The WAIT LED will be on when the 2140 controller is waiting for action by the host computer. The controller may be done with its previous operation and awaiting a new command, or it may be in the middle of an operation waiting for a data transfer to or from the host computer.

3. Read.

The READ LED indicates that the controller is attempting to read data off of a diskette.

During the execution of a READ command the controller performs a track seek (moving the drive head to the proper track), a sector seek (reading disk data looking for the proper sector), and finally a data read. The READ LED will be on during the sector seek and the data-read portions of the READ command.

The execution of a WRITE operation involves a track and sector seek and then a data-write operation. The READ LED will be on during the sector seek portion of the WRITE operation.

An initialize operation actually involves three basic operations: Controller self-test, drive "homing" (seeking track 00), and a partial bootstrap operation in which Unit 0, Track 1, Sector 1 is read and stored in the controller sector buffer. The READ LED will be on during the sector seek and data read portions of the read bootstrap operation at the end on an initialize operation.

4. Write.

The WRITE LED is on during any period of time in which the controller is actually writing on a diskette. As described above, a WRITE operation consists of a track and sector seek followed by a data-write operation. The WRITE LED will be on during the data-write portion of a write operation.

A track format operation involves seeking the proper track, waiting for the index mark on that track and then writing all of the required sector information onto the diskette. The WRITE LED will be on during the time that the controller is writing the sector information.

c. Drive Select Lights.

The individual LED's on each disk drive are the drive select indicators. These LED's are used as activity indicators for each drive. One and only one drive will be selected at a time so only one indicator will be on. These lights indicate that an operation is in progress on the indicated drive and that the user should not attempt to remove the diskettes from that drive until the light goes out.

C. Diskettes

The diskette is the most critical part of your system. No amount of system engineering can compensate for poor quality diskettes or for diskettes made unreliable through mishandling or abuse.

1. Approved Vendors.

The following is a list of sources for flexible disks to be used in DSD 210 systems. Data Systems Design makes no guarantees for the performance of unauthorized diskettes in DSD 210 systems, and warns the user that he uses such diskettes at his own risk (and peril).

APPROVED SOURCES:

DATA SYSTEMS DESIGN, INC.

DYSAN

SHUGART

IBM

2. Handling.

Floppy disks can be extremely reliable mass storage devices when handled properly. The user should observe the following precautions:

- a. Do not write on the jacket containing the diskette; all writing should be confined to labels and should occur before the label is placed on the diskette. If it is necessary to write on the label after it has been affixed to the jacket, use a felt tip pen only. DO NOT use a sharp writing instrument such as a pencil or ball point pen.
- b. Do not use paper clips on a diskette.
- c. Do not use writing instruments, such as lead or grease pencils, that leave flakes on the jacket of the diskette.
- d. When not in use, diskettes should be kept in their envelopes to prevent dust from gathering on exposed magnetic surfaces.

- e. Do not leave diskettes in the sun; they will melt.
- f. Be careful when loading or unloading a diskette from a drive, it is possible to damage the diskette if it is improperly handled.

3. Inserting Into Unit.

Diskettes are loaded into the drives so that the label is on the user's left side (see Figure).

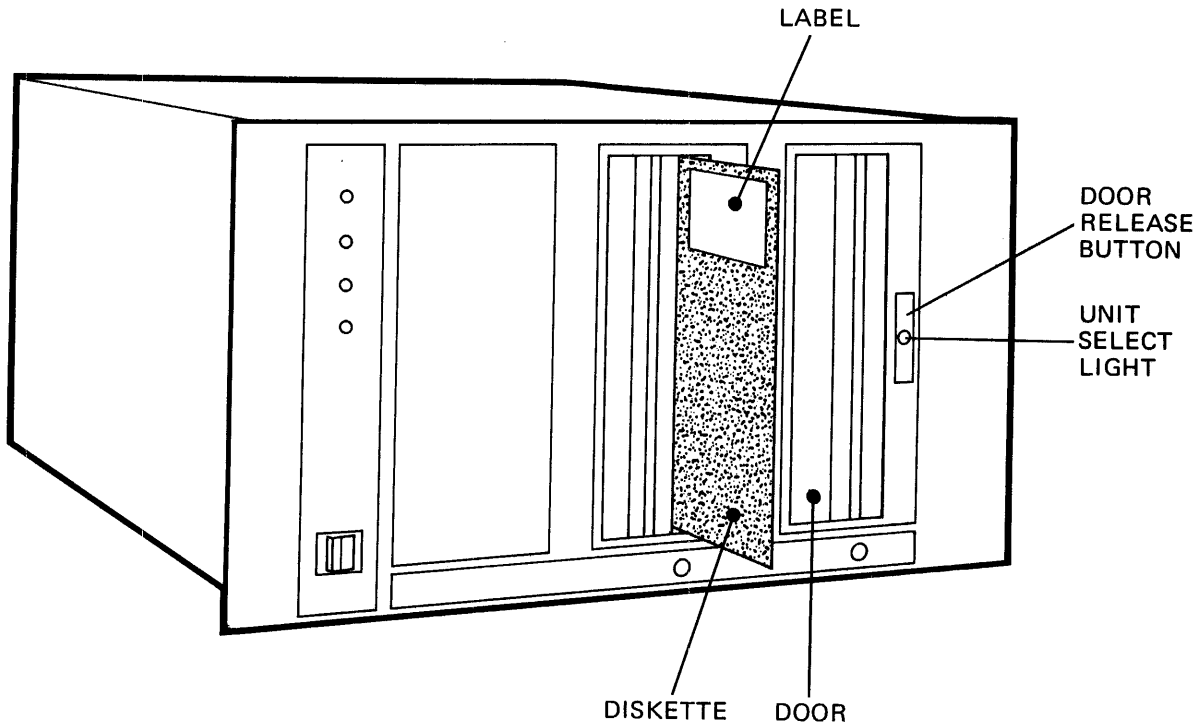

Fig. 15
Orientation of Diskette for Insertion

Place the diskette into the drive and, using one finger, press it back into the drive until the diskette appears to "catch" inside the drive (this should happen when the diskette is completely inside the drive). Do not attempt to capture the diskette in the drive by catching the front edge of diskette on the inside of the drive opening. Do not push so hard that the diskette bends. At this point the diskette will not pop out of the drive when you let go of it. As it is still possible to pull the diskette out of the drive, make sure that it is firmly seated at the rear of the drive. Move the drive door to the right until the door latches shut. The diskette is now ready for operation.

It is quite permissible to load or unload a diskette while the power is on and the diskettes are spinning. The only time when it is not permissible to load or unload diskettes is when a disk operation is actually in progress.

4. Write Protecting

Individual diskettes can be write protected in a DSD 210 system (note that this feature only applies to diskettes that have the Write Protect Notch or hole. Strictly speaking, IBM diskettes do not come with this hole). When the hole is left open the diskette is protected; when the hole covered, writing on the diskette is permitted. To permit writing on a diskette, place a tab over the hole on the front of the diskette and fold the tab over to cover the hole in the rear of the diskette. A diskette can be write protected by removing the tab.

WARNING: If an operating system has attempted to write on a write protected drive, do not switch the protect switch to off while the system attempts retries. When a retry is attempted, an initialize pulse is sent to the Formatter/Controller. It subsequently reads data from sector 1 of track 1 into the sector buffer. The operating system still thinks that the data it put in the SECTOR BUFFER is intact. (But we know that it is not.) Either wait for the retries to subside (usually 8 retries) or control C back to the monitor before you unprotect the diskette.

D. Acceptance Testing.

Each system is shipped with an acceptance test diagnostic program. The diagnostic program for the DSD 210-8 is called VEP 210. The diagnostic program for the DSD 210-11 and DSD 210-L11 is called FRDTST. The program is supplied on both a diskette and papertape. A program listing is also supplied. See the program listing for details on how to use the program. Make sure that blank diskettes are in the drives before starting the acceptance test. If the acceptance test does not run successfully, contact the factory for further instructions. The above mentioned programs are also used to format diskettes.

E. Operating System Requirements.

1. PDP-8.

The DSD 210-8 will operate under any DEC operating system that supports the RX8E. These operating systems include OS/8, RTS8 and the business operating systems. If you have an operating system which has device handlers for the RX8E, then no modifications are required to run the DSD 210-8. Simply install the hardware and refer to the floppy in the normal operating system dialogue.

If you do not have the device handler for the floppy in your system, then two alternatives are open to you, in order to run the DSD 210-8. First, get a current update of your operating system from DEC, preferably on floppy disks, or second, incorporate the appropriate device handlers into your system. In either case, the DEC software will work on the DSD 210-8 as well as on the RX8E.

2. PDP-11 and LSI-11.

The DSD 210-11 and the DSD 210-L11 will operate under any DEC operating system that supports the RX-11 on the RXV-11. If your current system does not support floppies, then purchase a current update of your operating system from DEC. If you do not have any disk operating software, then an operating system that supports floppies must be purchased from DEC. DSD does not supply DEC software with its systems. RT-11V2C will work equally well on the PDP-11 and the LSI-11. It is not possible to generate a MONITR.SYS file for booting and running RT-11 off of a floppy without RT-11 sources and 20K of memory. Although DEC's literature suggests that RT-11 will run in 8K of memory, 16K is a much more reasonable amount of memory.

F. BOOTSTRAPPING.

1. PDP-8.

The DSD 210-8 can be bootstrapped using all of the same methods used to boot DEC's RX8E. These methods include loading the boot into memory manually through the switch register, loading the paper tape boot using the absolute binary loader, or initiating a hardware bootstrap operation.

For those who will be loading the OS/8 boot in manually, we have written a shortened form of the OS/8 floppy boot. The difference between DEC's 30 work boot and our 15 work boot is that DEC's will try to boot off of unit 1 if it fails to boot off of unit 0. The DSD boot assumes that a bootable diskette is loaded into unit 0; not an unreasonable assumption. The abbreviated OS/8 bootstrap follows:

/ MINIMAL BOOTSTRAP FOR DSD-210 FLOPPY PAL8-V9B 02/24/77 PAGE 1

/ MINIMAL BOOTSTRAP FOR DSD-210 FLOPPY DRIVE 0.
/ FBOOT.PA 5/28/76

6751 LCDR=6751
6752 XDR =6752
6753 STRF=6753
6755 SDNF=6755

/ DRIVE 0 IS THE LEFT HAND DRIVE ON ALL SYSTEMS.
/ PLACE THE DISKETTE WITH THE LABEL TO THE LEFT IN ALL
/ SHUGART DRIVE SYSTEMS.
/ THE SYSTEM MUST BE INITIATED BEFORE CONTINUING AT 33. THIS
/ CAUSES THE DRIVE LIGHTS TO CYCLE AFTER A DELAY OF ABOUT
/ .5 SEC.

0032 #32
00032 7402 START, HLT /USED FOR CALLING IN ONLY.

/ AFTER LOADING (33-35) (45-60) HIT CLEAR AND
/ START AT 33.

00033 6755 CKDN, SDNF
00034 5054 JMP XFSUB+1
00035 5045 JMP UNLOAD-1
0045 #45
00045 7326 CLA STL RTL / SET AC = 2
00046 6751 UNLOAD, LCDR
00047 4053 DATLP, JMS XFSUB
00050 3002 DCA 2
00051 2050 ISZ -1
00052 5047 JMP DATLP

00053 6753 XFSUB, STRF / CAN BE ANYTHING!
00054 6753 STRF
00055 5033 JMP CKDN
00056 6752 XDR
00057 5453 JMP I XFSUB

00060 7004 SELCT, 7004 / FOR DRIVE 0.
/ 7024 FOR DRIVE 1.
\$ \$ \$ \$

The bootstrap is initiated by first either executing a Clear-All-Flags instruction or a floppy initialize instruction or by depressing the Clear button on the computer. Any of these actions causes the DSD 210 to read the contents of unit 0, track 1, sector 1 into the Sector Buffer. The bootstrap program is then executed. It unloads the Sector Buffer and continues with the booting process.

2. PDP-11.

The DEC supported operating system that one would want to boot off of floppy is RT-11. There are a number of ways that RT-11 can be bootstrapped on a PDP-11. On systems that have a switch register or an octal front panel the bootstrap can be loaded through the switches. A minimal program which accomplishes booting RT-11 from the switches is:

DEC's published bootstrap required more instructions than the above listed DSD bootstrap because DEC's will boot off of Unit 1 if Unit 0 does not have a diskette in it. We feel that the convenience of keying in fewer instructions out-weighs the option of booting off of Unit 1. By convention, the system diskette is usually loaded into Unit 0. The longer DEC bootstrap will work equally well on the DSD 210-11 and the RX11.

On DSD systems whose floppy interface board is equipped with the optional hardware bootstrap, the system can be booted by starting the processor at location 173000. Successful booting requires that the interface is equipped with the RT-11 bootstrap PROMs and that the bootstrap disable jumper on the interface has been removed.

On systems that have the front panel emulator, namely the PDP-11/04, /34, a hardware floppy bootstrap is included in the emulator code. If the OEM version of one of these processors is being used, switches on the terminator/ROM board can be set so the system can be booted by switching the initialize/boot switch on the processor's front panel to initialize and then back to the boot position. Alternatively, the console emulator code can be entered and DX0 (CR) can be typed to boot the floppy system. On end user versions of the processors, this last method must be used to boot the floppy system.

The DSD 210-11 has an optional hardware bootstrap built into the interface board. The peripheral device register addresses that are assigned to the bootstrap are within the address space of the front panel emulator code on PDP-11/04's and PDP-11/34's. To avoid any conflict in addressing, a jumper on the DSD 210-11 interface board completely disables the bootstrap on the interface board. When the jumper is installed, no conflicts will occur.

Regardless of the booting method, all the bootstraps work in about the same way. The first objective of the bootstrap is to load the contents of Sector 1 Track 1 into memory starting at location zero. This code is then executed starting at location zero, with R0 set to the drive number that is to be booted off of. That code reads in the remaining contents of blocks 0 and 2 (sectors 3,5,7 and sectors 21,23,25,27). This code does all further initialization and reads in MONITOR.SYS.

Since a RESET command forces a floppy initialization sequence which includes reading the contents of drive 0, track 1, sector 1; the minimal keyed in bootstrap must only empty the sector buffer into memory and start at location zero.

```

1          .TITLE  FLOPPY RT-11 BOOTSTRAP
2
3          000000          .ASECT
4          001030          .=1030
5
6          .MCALL          .REGDEF
7          001030          .REGDEF
8
9          177170          RXCS=177170
10         177172          RXDB=177172
11
12
13         ; BOOTS.MAC          = FLOPPY BOOTSTRAPS.
14
15         ; MINIMAL RT-11 BOOTSTRAP FOR DSD-210 FLOPPY CONTROLLER.
16         ; PUT A RT-11 DISKETTE (CONTAINING MONITR.SYS) INTO THE
17         ; LEFT DRIVE (UNIT 0) WITH THE LABEL FACING TO THE LEFT.
18         ; WRITE PROT. THE DRIVE WHILE BOOTING IF DESIRED AND
19         ; START AT 1030. NOTE: THIS BOOTSTRAP IS IN POSITION
20         ; INDEPENDENT CODE AND CAN BE LOADED AND EXECUTED ANYWHERE.
21
22
23         01030  005000  FLPBOT:  CLR          R0          ; IF DRIVE L
24         01032  012702          MOV          #100247, R2 ; 100267 IF DRIVE L
25         01036  000005          RESET        ; READ SECTOR 1, TRACK 1
26         01040  012701          MOV          #RXCS, R1 ; RXCS
27         01044  005711          TST          (R1)
28         01046  001776          BEQ          .-2
29         01050  100766          BMI          FLPBOT ; ERROR - RETRY.
30         01052  010104          MOV          R1, R4
31         01054  012724          MOV          #3, (R4)+ ; EMPTY BUFFER
32         01060  005003          CLR          R3          ; DELAY A LITTLE
33
34         01062  105711  4$:      TSTB         (R1)
35         01064  001776          BEQ          .-2
36         01066  100002          BPL          6$          ; MUST BE DONE
37         01070  111423          MOVB        (R4), (R3)+ ; LOAD STARTING AT 0.
38         01072  000773          BR          4$
39
40         01074  005007  6$:      CLR          PC

```

Fig. 17

3. LSI-11, LSI-11/2

RT-11 can be bootstrapped on the LSI-11 in a number of ways. First, the bootstrap can be entered and executed through the resident ODT. An easier method, if a paper tape reader is available, is to use the paper tape bootstrap loader in the resident monitor. The loader can be used to load in a paper tape containing the floppy bootstrap and to start the booting process. An LSI-11 bootstrap tape, which is provided with each DSD 210-L11, can thus be loaded by placing the leader (351 code) in the reader and typing 177560L (if low speed reader) or 177550L (if high speed reader). The tape will then be read in and started and RT-11 will boot up within 15 seconds after the tape stops.

Another method of bootstrapping RT-11 on the LSI-11 is through a hardware bootstrap. DEC's REV11 or the DSD LSI-11 on board bootstrap can be used to boot the system. Included on the DSD 210-L11 interface board is a hardware bootstrap, a refresh circuit for dynamic mos memory and bus terminators. These added features of the DSD 210 interface for the LSI-11 eliminate the need for DEC's REV-11 board in most cases.

When using the hardware bootstrap two options are available to the user. He can either strap the processor board to come up executing the bootstrap code upon initialization or he can come up in ODT and type: "173000G (CR)".

```

1          .TITLE  FLOPPY RT-11 BOOTSTRAP
2
3          000000      .ASECT
4          001030      .=1030
5
6          .MCALL      .REGDEF
7  001030      .REGDEF
8
9          177170      RXCS=177170
10         177172      RXDB=177172
11
12
13         ; BOOTS.MAC      = FLOPPY BOOTSTRAPS.
14
15         ; MINIMAL RT-11 BOOTSTRAP FOR DSD-210 FLOPPY CONTROLLER.
16         ; PUT A RT-11 DISKETTE (CONTAINING MONITR.SYS) INTO THE
17         ; LEFT DRIVE (UNIT 0) WITH THE LABEL FACING TO THE LEFT.
18         ; WRITE PROT. THE DRIVE WHILE BOOTING IF DESIRED AND
19         ; START AT 1030. NOTE: THIS BOOTSTRAP IS IN POSITION
20         ; INDEPENDENT CODE AND CAN BE LOADED AND EXECUTED ANYWHERE.
21
22
23  01030  005000  FLPBOT:  CLR      R0      ; IF DRIVE L
24  01032  012702  MOV      #100247, R2 ; 100267 IF DRIVE L
25         100247
26  01036  000005  RESET   ; READ SECTOR 1, TRACK 1
27  01040  012701  MOV      #RXCS, R1 ; RXCS
28         177170
29  01044  005711  TST     (R1)
30  01046  001776  BEQ     .-2
31  01050  100766  BMI     FLPBOT ; ERROR - RETRY.
32  01052  010104  MOV     R1, R4
33  01054  012724  MOV     #3, (R4)+ ; EMPTY BUFFER
34         000003
35  01060  005003  CLR     R3 ; DELAY A LITTLE
36
37  01062  105711  4$:    TSTB   (R1)
38  01064  001776  BEQ     .-2
39  01066  100002  BPL     6$ ; MUST BE DONE
40  01070  111423  MOVB   (R4), (R3)+ ; LOAD STARTING AT 0.
41  01072  000773  BR     4$
42
43  01074  005007  6$:    CLR     PC

```

Fig. 18

IV. Maintenance.

A. Philosophy.

The DSD 210 was designed to require minimal periodic maintenance. The fan filter and the drive head-load pads are the only parts of the system that could require periodic maintenance.

If the DSD 210 should fail, it is the charter of Data Systems Design to repair the unit as quickly as possible at minimum expense to the user. Quick repair can best be accomplished through a cooperative effort between the user and Data Systems Design.

The user is asked to make a few simple observations on his malfunctioning unit. The self-testing features of the DSD 210 and the comprehensive diagnostic programs that are provided with the system supply the data for the users observations. From these observations Data Systems Design personnel will determine the source of the failure. Data Systems Design will then immediately send the module that is required to repair the faulty unit to the user via the fastest mode of transportation.

The user is then expected to swap out the faulty module for the good one. Because the DSD 210 is extremely modular, this swap can be accomplished with a screw driver and an allen wrench. A soldering iron is not required. The four modules that are subject to failure are the drive, the Formatter/Controller, the power supply, and the interface board.

The result of this cooperative effort is minimum down-time and low maintenance costs for the users. Down-time can further be shortened by maintaining a stock of spare parts.

In any case, when a DSD 210 floppy disk memory system is "down" at a customer's site, the people at Data Systems Design will give their best effort to get it back on-the-air. You can count on it!

B. Maintenance Features.

1. Self-Testing Routines.

The PROM's on the Formatter/Controller (F/C) board contain self-testing routines that are executed by the microprocessor on the F/C board. The self-testing routines are executed whenever the unit is powered up or when the INIT signal is received from the processor. Completion of these routines is signaled by the audio "clicking" or as we call it "ruba-duba" of the drives as they are initialized to the home position. The sound of this drive "homing" action is more audible if diskettes are in the drives and the drive doors are closed. The host processor and the floppy interface board do not participate in the self-testing procedure and thus, need not be present during the execution of the self-testing routines. The sequence of these self-testing routines is as follows:

- a) The microprocessor tests itself by executing shift routines and simple arithmetic operations.
- b) A "walking ones" and "walking zeros" test is executed on the ram buffer memory.
- c) The microprocessor then sets or clears any flip-flops that it can programably control and does test bit instruction to confirm the successful execution of these operations.
- d) The F/C then "homes" each drive. "Homing" a drive is accomplished by stepping the Read/Write head ten tracks toward the center of the diskette. This operation insures that the head is inside track zero before track zero is sought. The head is then stepped toward the outside tracks of the diskette until the drive signals the controller that the track zero position has been reached. The "Track Zero Sensor" is part of the drive and only determines the position of the Read/Write head carriage. A diskette need not be present in the drive for this "homing" operation to occur. Logical Drive 1 is "homed" first, then logical Drive 0 is "homed".
- e) If a diskette is in logical Drive 0, the F/C will confirm that it is up-to-speed by measuring the time between occurrences of the index mark hole on the diskette. This time measurement is accomplished by the use of accurate timing routines in the microcode. If logical Drive 0 has a diskette in it and the diskette is up-to-speed (360 RPM) then the F/C steps the head in one track and reads Track 1, Sector 1 into the sector buffer ram. During the read operation sector ID marks are read until the Sector 1 ID is found. Whenever a sector ID is read (2 bytes) a CRC code is generated and compared with the CRC code which follows the sector ID. Whenever data is read, a CRC code is generated and compared with the CRC code which follows the data sector. After the self-testing routines have been completed, the INIT LED on the F/C board will light. If an error occurs during any of the above mentioned operations, it will be reported on one or more of the four error status indicators on the front panel of the unit. If the microprocessor is so disabled that it cannot execute the self-testing routines then the absence of the "rub-a dub-a" sound of the drives "homing" will indicate this catastrophic failure.

2. Error Indicators

The four vertically arranged LED's on the left side of the front panel are the error status indicators. These LED's signal that an error condition exists and suggest the possible cause of the condition. Most error conditions are either caused by operator error or faulty media. The inclusion of the LED's on the front panel was meant to minimize unnecessary service calls. If a hardware failure does occur these LED's will indicate the presence of the failure and aid in diagnosing the cause of the failure. The four error status indicators are the DATA LED, the PARITY LED, the SEEK LED and the CONTROLLER LED.

DATA

The DATA LED is illuminated when a CRC error has been detected on a data sector that has been read. This error often suggests that worn or dirty diskettes are being used. To confirm that the problem is associated with the diskettes and not the hardware, run the acceptance test portion of the diagnostic program using new certified diskettes. The DATA LED also indicates that the INDEX hole cannot be found on a format operation.

PARITY

Communication between the computer interface board and the F/C is accomplished using a single bi-directional data line; data transfers are serial in nature. The computer interface board appends a parity bit onto the end of each transmission. The F/C board checks the parity of each command that it receives and verifies the integrity of the interface cable. If a parity error occurs, the operation is aborted and the parity error indication is given. Although the cable connectors are keyed, they can be connected backwards if enough force is applied. A misconnected interface cable will cause a parity error.

SEEK

Seek errors occur when the desired sector header cannot be found or when the track byte or the header as read from the diskette does not match the expected value. A seek error will also occur if the logical unit assignment switched on the F/C board are improperly set. A seek error will occur if no drive is assigned as logical Drive 0.

CONTROLLER

Two types of problems can cause controller errors; either the F/C detected an error in its own operation during the self-testing procedure or the controller detected a "write-protected" condition when a write operation has been called for. The write protected condition could be due to the associated write protect switch being in the "write-protect" position or due to the "write-protect" notch on the diskette being exposed. Not all diskettes have "write-protect" notches.

3. Logical Drive Assignment Switches

The DIP switches on the F/C board assign logical unit numbers to the physical diskette drives. The chassis is built with physical Drive Zero on the right and logical Drive Zero on the left. The logical unit assignment switches are used to isolate a faulty drive or to decide whether a fault is due to a drive problem or a controller problem. If a fault seems to be associated with one logical drive then the logical drive numbers should be reversed to see if the problem moves with the logical drive or stays with the physical drive. If a problem is common to both drives then it probably is not a drive problem.

4. Controller Board Test Points.

Test Point 1 - VCC

5 Volts to 5.1 Volts relative to test point 8.

Test Point 2 - Missing Clock

Test Point 2 is connect to the missing clock line. This line should be normally low. It should flash high for a brief period whenever an address mark passes under disk drive head.

Test Point 3 - Disk Data

This line is separated disk data (i.e., the clocks have been removed).

Test Point 4 - Power Low

This line will be low whenever the power supply sense circuitry senses that VCC is less than 4.85 volts.

Test Point 5 - Clock Time

Test Point 5 will contain low-true pulses of one micro-second duration whenever the data separator decodes a clock pulse coming from the disk drive.

Test Point 6 - Unseparated Data

This is raw data coming from disk drive. It is a low-true signal.

Test Point 7 - P Stack Clock

Test Point 7 is connected to the master clock. If the clock is operating properly, the user will see a frequency of 4 megahertz on test point 7. The signal at test point 7 will be high for a period of 150 micro seconds and more than .01% from 4 megahertz, then there is something wrong with the oscillator on the controller board.

Test Point 8 - Ground

5. Modularity

This unit was designed with ease of on-site maintenance in mind. If a hardware error occurs the repair should be accomplished by determining what major module has failed and replacing it. Major modules are defined to be the diskette drives, the Formatter/Controller (F/C) board, the power supply, and the interface. Each major module is easily replaced in the unit. The top cover is secured by Zeus Fasteners. The F/C board can be removed by unmounting it from its squeeze fasteners and removing all the cables. The power supply can be removed by unplugging it from the rest of the unit and unbolting it from the back panel. The drives can be removed by removing the front panel using an allen wrench, then disconnecting the three cables from the back of the drive, and finally by removing the three bolts that secure the drive to the chassis. Repairs to the individual

modules should either be done on a bench set-up or at the factory.

6. Diagnostic Programs.

The diagnostics programs were carefully written to thoroughly test the floppy disk unit. The diagnostic for the LSI-11/PDP-11/03 and for the PDP-11 is called "FRDTST". The diagnostic for the PDP-8 is called "VEP210". The diagnostics are provided on both paper tape and diskette. The absolute loader is used to load the paper tapes and the appropriate operating system can be used to load in the diagnostic off diskettes. Instructions on how to use the diagnostic programs are included in the first few pages of the program listings. When running the diagnostic be sure to remove the diagnostic diskette after the program has been loaded. If the diagnostic is run on the diagnostic diskette the programs will be lost. Blank certified diskettes should be used when the diagnostic program is used to check out the unit.

C. Diagnosing a Problem

1. Indications On Power-Up and Initialization.

The first step in diagnosing a problem with the DSD 210 is to observe what happens when the unit is powered-up. Does the light in the power switch go on when you switch it to the "on" position? If not check the AC outlet that the DSD 210 is plugged into. If the light does not go on and AC is ok then proceed to Section 3 (AC and DC fuses) and 4 (checking the power supply voltages) for further suggestions. As a last resort, check the bulb in the power switch. If the light in the power switch does come on then you know that approximately +5 volts is applied to the formatter/controller board.

When you power the unit up, logic on the formatter/controller should initialize the floppy subsystem. If diskettes (should be blank diskettes if you suspect the floppy subsystem is bad) are in the drives and the drive doors are closed then an audible ruba-duba should be observed while the drive activity LED's blink in sequence. If no ruba-duba occurs then something is wrong with either the formatter/controller board or the power supply. First suspect the power supply and see Section 4 for action to be taken. If the power supply proves operational, then the formatter/controller should be suspected. When a F/C is really bad the error indicators come up in random patterns when the unit is powered up. If the F/C is suspected, reseal all the connections at the edge of the board and reseal the IC's that are in sockets. If this doesn't help then call factory or salesman for replacement F/C board. Remember that the above description pertains to those instances where ruba-duba does not occur on power-up.

If ruba-duba does occur, that is, if the drives do "home" at the end of the self-test sequence then further observation is required. Take the cover off the chassis of the unit by loosening the four quarter turn fasteners at the corners of the top cover. When the unit is turned on, observe the four LEDs on the top left hand corner of the formatter/controller board. The "INIT" light should light first, then after both drives have been "homed" the "read" LED should flash as Track 1, Sector 1 of Drive 0 is read into the sector buffer ram. The READ LED will only come on if a diskette is in drive 0 and the door is closed. Finally the "wait" LED should light indicating the formatter/controller is waiting for some action from the interface. If these lights sequence properly then observe the front panel error indicators. If an error occurs consistently on power-up, see Section IV-2 for explanation of error indicators. Next try to isolate the error to the formatter/controller or to one of the drives. Be sure that fresh blank diskettes are being used for this exercise. If an error occurs, reverse the logical unit numbers assigned to the two drives. See Section 5 of this chapter. Power the unit up and see if the error remains. The read operation in the initialize sequence only occurs on Drive 0, so by reassigning the drive numbers you are changing the drive on which the read operation occurs.

If you cannot change the error conditions by reassigning drive numbers then try deassigning the drives. First assign one drive as Drive 0 and deassign the other. Do the power-up sequence and observe. Then assign the other drive to Drive 0 and deassign the first one. Power-up and observe. If no change occurs then do the same procedure and remove the 50 conductor cable from the back of the deassigned drive. If no change occurs then measure the 24 volts and the minus 9 volts on the back plane. If all is well then the errors are caused by the formatter/controller. Again, be sure that the diskettes are not the cause of the problem. If any of the above operations does change the indications, then by a process of elimination you should be able to determine which drive is bad.

2. Checking the Diskettes.

Diskettes can be checked by scanning them using the appropriate diagnostic program provided with the system. The programs are FRDTST on the PDP-11 or LSI-11 or VEP 210 on the PDP-8. The slash K option in RT-11 PIP will also scan diskettes for bad blocks.

If you suspect a head alignment problem, scan new unused diskettes on both drives. If bad reads occur on one drive only the head on that drive is probably out of alignment. Reformat a diskette on the misaligned drive. The scan should be successful on the reformatted diskette on the misaligned drive. If not, then head alignment is not the problem.

3. The system has three fuses. The AC fuse behind the plexiglass plate and the two DC fuses on the power distribution panel. Check each with an OHM meter.

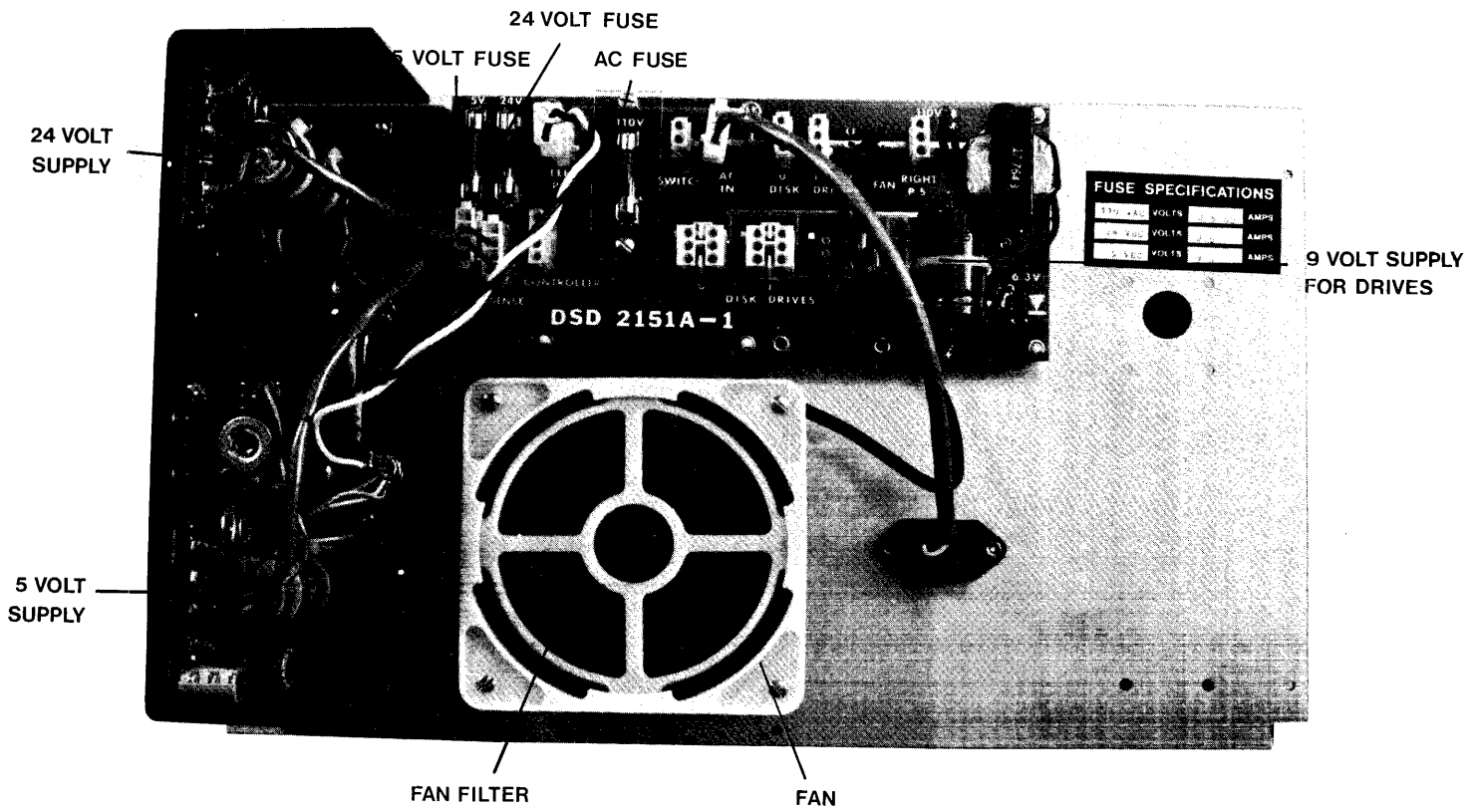

Fig. 19
Fuses

4. Checking the Power Supply Voltages.

The 5 volt supply should be checked across test points 1 and 8 on the lower right hand corner of the formatter/controller board. 5.1 volts should be read at this point.

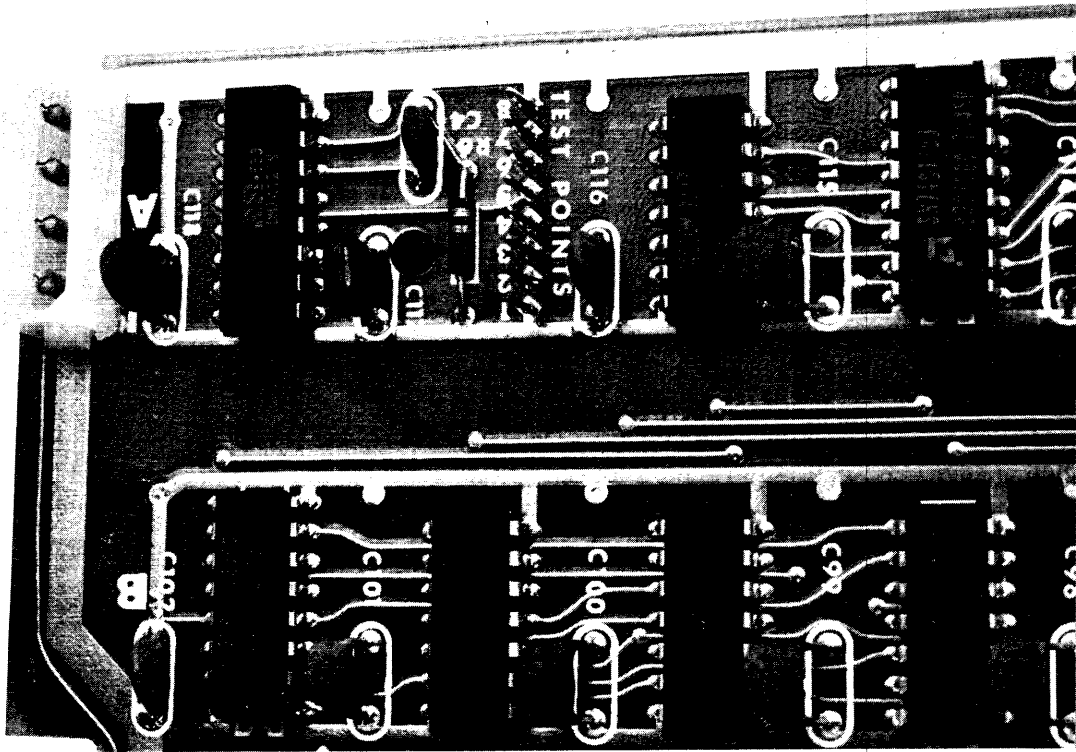
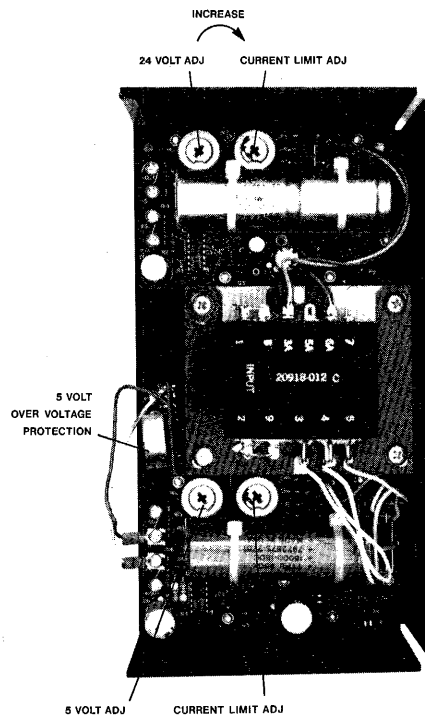

Fig. 20
TEST POINTS

Check the 24 volts and the minus 9 volts on the power distribution board.



*POWER TEC

P1 = 5V ADJUST

P2 = CURRENT LIMIT

MICROCOMPUTER POWER

P1 = CURRENT LIMIT

P2 = 5V ADJUST

*As shown in Fig. 21

Fig. 21
POWER SUPPLY ADJUSTMENTS

The 5 and 24 volt supplies both have voltage adjust and current limit adjust. If the voltage on one of the supplies is low but not close to 0 volts then adjust the voltage adjust to bring the supply back up to the proper level.

If the output voltage is close to 0 volts then the current limit circuit could be shutting the supply down. Unplug the output of the supply from the rest of the system. If the voltage comes back up to normal then the supply is current limiting either because one of the elements of the system is shorting the supply or because the current limit circuit is set too low. Reconnect the output of the supply to the rest of the system. Unplug the other elements of the system (drive, formatter/controller) to determine which of the above cases is present. If you suspect that the current limit is set too low, then adjust the voltage down until the current limit circuit stops limiting. Adjust the current limit up and then readjust the voltage. The 5 volt supply also has an over voltage protection circuit. If the OVP is shutting the supply down, then adjust the voltage of the supply down until the OVP circuit cuts out. If it cuts out below 5 volts then unplug the supply from the rest of the system and adjust the OVP up to 6 volts and the supply back to 5.1 volts.

5. Deassigning or Reassigning Logical Drives.

The microprocessor on the F/C board checks the DIP-switches on the upper left hand corner of the board for an indication of how many drives are in the system and which logical unit number is assigned to which drive. Pairs of DIP-switches are associated with each drive.

6. Isolating the Problem.

The point of the previous sections is to isolate a hard fault. There are four major modules in the system that could cause an error condition. They are the drive, the formatter/controller, the power supply, and the interface. See the following section if interface problems are suspected.

Fault isolation is accomplished by a process of elimination. If nothing happens when power is turned on then either the power supply is bad or the formatter/controller is bad. Check the power supply. If the drives "home" (indicated by audible ruba-duba) then the power supplies are probably ok.

The next step is to eliminate either the F/C or the drives as a cause of the fault. Use the logical unit assignment switches to reassign and deassign drives. If an error cannot be isolated to one of the drives then the F/C is probably bad. If "none of the above" then run the diagnostic program.

7. Diagnostic Programs.

Each unit that is shipped includes a diagnostic diskette, a blank diskette, a diagnostic paper tape, and a listing of the diagnostic program. The program for the PDP-11 and the LSI-11 systems is called "VEP210". You will find the listings of these programs in the rear of the software manuals. An explanation of how to use the program and how to interpret the results is included in the listing. DO NOT RUN THE DIAGNOSTIC PROGRAM OVER THE DIAGNOSTIC DISKETTE! USE THE BLANK ONE!

D. Repairing the Unit.

1. Replacing the Formatter/Controller Board.

- a. Unplug the AC power cord from the outside of the rear panel of the box.
- b. The Formatter/Controller is the large board on the left hand wall of the box.
- c. Remove the top cover of the unit.
- d. Remove the two connectors at the top of the F/C board.

- e. Remove the power connection at the bottom right hand corner of the board.
 - f. Remove the board from the wall of the box by pinching the exposed part of the Ritchco fasteners and pulling the board off the end of the fastener.
 - g. Finally remove the 50 conductor cable from the rear edge of the board.
 - h. Reverse the process to install new board.
2. Replacing a Drive.
- a. Unplug the AC power cord from the outside of the rear panel of the box.
 - b. Remove the top cover of the unit.
 - c. Remove the 50 conductor cable and the two Mate-N-Lock connectors from the rear of the drive.
 - d. Remove the front most connector on the F/C board.
 - e. Remove the front panel by removing the four allen screws at the corners of the front panel.
 - f. Set the front panel in such a way that wires to the power switch do not get stressed. Alternatively pull the power switch wires off the rear of the switch noting which wire went to which contact.
 - g. Remove the screw that secures the drive to the top cross bar.
 - h. Remove the two screws from the bottom of the unit that secure the drive to the chassis.
 - i. Sometimes the other drive must be partially removed to replace the right hand drive.
 - j. Reverse the process to install a drive.
3. Replacing the Power Supply.
- a. Unplug the AC power cord from the outside of the rear panel of the box.
 - b. Remove the top cover of the unit.
 - c. Pull the two DC connectors and the AC connector leading from the power supply to the power distribution card off of the power distribution card.

- d. Unbolt the supply.
 - e. Reverse the operation to install new supply.
 - f. Check voltages of new supply after it has been connected to the system.
4. Replacing the Interface Board.
- a. Remove power from the computer.
 - b. Remove computer cover.
 - c. Pull interface card out of computer card slot.
 - d. Remove signal cable from interface card.
 - e. When plugging signal cable into interface card observe that one connector pin on the header on the card has been clipped and one hole on the connector at the end of the cable has been plugged. Match the two.
 - f. Reverse the operation to install an interface board.

DSD-210-11
SOFTWARE DOCUMENTATION

The source listing for the following documentation is contained on the boot diskette, included with the manual.

FRDTST definitions and command descriptions from the listing are given on the pages following.

<u>SOURCE TITLE</u>	<u>DESCRIPTION</u>
1) BOOTS.MAC	MINIMAL LENGTH BOOTSTRAP
2) BOOTS.MAC	DEC PDP-11 BOOTSTRAP
3) LSPPIP.MAC	LOW SPEED PUNCH PIP
4) LSRPIP.MAC	LOW SPEED READER PIP
5) FLPBOT.MAC	LSI-11 "L" MODE PAPER TAPE BOOT
6) DXV3.MAC DXV2C.MAC	DSD-210 RT-11 HANDLER'S FOR RT-11 V2C, V3
7) FRDTBT.MAC	SECONDARY BOOTSTRAP FOR LOADING FRDTST.SAV DIRECTLY WITHOUT RT-11
8) FRDTST.SAV	FRDTST "FLOPPY READ TEST" DIAGNOSTIC INCLUDING FORMAT OPTION

1
2
3

```

.TITLE FRDTST - FLOPPY READ-WRITE TEST
; FRDTST.MAC 17-NOV-78 DSD FLOPPY READ-WRITE TEST ABSOLUTE.
SBTTL OPERATIONAL DESCRIPTION
; *****
; OPERATIONAL DESCRIPTION
; *****
; FRDTST - LOADING AND STARTING.          REQUIRES 8 K MEMORY
; FROM WITHIN RT-11 TYPE
; . "R FRDTST<CRLF>"
;           FRDTST TYPES OUT "REMOVE DIAGNOSTIC DISKETTE"
;           AND BRIEF OPERATIONAL DESCRIPTION.
; FROM PAPER TAPE LOAD USING ABSLDR, FRDTST WILL START
; AND TYPE OUT BRIEF OPERATIONAL DESCRIPTION
;
; FRDTST WILL ASK "MODE" AFTER IT IS CALLED IN OR AFTER
; IT HAS FINISHED THE PREVIOUS TEST OR A CNTRL R IS TYPED.
;
; RUNNING THE ACCEPTANCE TEST - EXERCISER
; TYPE "A" TO 'MODE: '. FRDTST WILL DO A
; GRADED SEQUENCE OF TESTS INCLUDING RANDOM
; READ-WRITE AND ENDING WITH A SEQUENTIAL READ
; PASS AND WILL TYPE OUT ANY ERRORS FOUND.
;
; EXAMPLE - QUOTED CHARACTERS ARE TYPED BY USER
; . "R FRDTST<CRLF>"
; REMOVE DIAGNOSTIC DISKETTE
; < ADDITIONAL DESCRIPTIVE TEXT >
; FRDTST V5B
; #MODE: "A" CCEPTANCE TEST
; FILL-EMPTY CRC CHECKED WRITING READING
; INTERRUPT ENABLED WRITING READING RANDOM R-W
; READING PASS FIN
; BAD/GOOD 0 / 47000(APPROX)
; < THE ABOVE REPEATS UNTIL STOPPED WITH CTRL R>
; WHERE FILL-EMP IS TYPED WHEN STARTING
; THE BUFFER FILL-EMPTY TEST
; "CRC CHECKED" BEFORE A CRC CHECK SCAN
; "WRITING" TYPED BEFORE WRITE SEQUENTIAL
; "READING" TYPED BEFORE READ SEQUENTIAL
; "INTERRUPT ENABLED" ENABLES INTERRUPT
; "WRITING" - ANOTHER WRITE THEN READ PASS
; "RANDOM-RW" RANDOMLY READ/WRITE UNTIL
; 1000(8) READS
; "READING" BEFORE A SEQUENTIAL READ-ONLY
; SCAN OVER THE RANDOMLY WRITTEN DATA.
;
; TYPE CONTROL R OR START AT 1104 TO RESTART FRDTST AT "MODE: "
;
; SPECIAL CHAR CODES AND RESULTS
; CTRL R  RESTARTS AT "MODE"
; CTRL S  HANG OUTPUT TO TERMINAL UNTIL ANOTHER CHAR TYPED
; CTRL D  THROWS AWAY OUTPUT UNTIL ANOTHER CHAR
;         IS TYPED OR UNTIL FLAG RESET.
; CTRL P  INHIBITS ALL PRINTOUT EXCEPT FOR ERRORS.
;         RESET BY ANY OTHER CHAR TYPED IN.
; CTRL C  ASKS "EXIT TO RT-11?". TYPE "Y" TO EXIT.
; CTRL D  ODT DISPATCH      NOTE: C OR "1100G" RETURNS
    
```

```

; CTRL T ODT DISPATCH WITH STACK TRACE.
;
; FRDTST TYPES <CRLF># WHEN STARTED THEN ATTEMPTS AN INIT.
; TYPES "MODE:" WHEN INIT IS SUCCESSFUL.
; USER TYPES KEY CHARACTERS IN ( ) TO SELECT DESIRED MODE.
;
; *****
; OPERATIONAL MODES:
; *****
; SPECIFY THE MODE BY TYPING THE CHARACTER STRING ENCLOSED
; IN PARENTHESIS IN RESPONSE TO "MODE:"
; * THE MOST USEFUL MODES ARE ASTERISKED *****
; THE AVAILABLE MODES ARE
;
; * (H)ELP TYPES ALL COMMANDS AVAILABLE IN TEST
; * (A)CCEPTANCE DOES FILL-EMPTY BUFFER CHECK, THEN
; SEQUENTIAL WRITE-READ, THEN SETS INTER-
; -RUPT ENABLE AND DOES EVERYTHING AGAIN
; THEN DOES RANDOM READ WRITE
; FOLLOWED BY A READ ALL TO CHECK DATA.
; NOTE: THIS SEQUENCE SWITCHES THE DATA
; GENERATION ALGORITHM AFTER EACH PASS.
; (F)ILEMP FILLS AND EMPTIES SECTOR DATA BUFFER
; CHECKING FLAGS, COUNTS AND DATA.
; * (SEGW)R SEQUENTIALLY WRITES DATA ON ALL SELECTED
; DRIVES THEN READS ALL AND CHECKS DATA.
; PRINTS "WRITING" WHEN STARTING WRITE PASS
; PRINTS "READING" WHEN STARTING READ PASS
;
; NOTE: ***** THE FOLLOWING 3 TESTS REQUIRE A SEQUENTIAL
; WRITE PASS BE DONE FIRST IN ORDER TO
; INITIALIZE THE DATA. (SEE DATA FORMAT)
;
; * (SEQR)D SEQUENTIALLY READ ONLY AND CHECK DATA ON
; ALL SELECTED DRIVES.
; PRINTS "READ PASS" AT END OF EACH PASS.
; (RN)D RW RANDOMLY GET A SECTOR ON SELECTED DRIVE
; THEN READ OR WRITE IT CHECKING DATA.
; * (RD) RANDOM READ RANDOMLY SELECTED SECTORS ON
; AND CHECK DATA READ
; * (SC)AN READ ALL SECTORS ON SELECTED DRIVES AND
; CHECK FOR CRC ERRORS.
; (RA)NDOM RANDOMLY SELECT AND READ SECTORS ON
; SELECTED DRIVES CHECKING STATUS ONLY.
; (SK) RANGE SEEKS REPETITIVELY THROUGH A RANGE
; COVERING ALL SELECTED TRACKS
; (SA) 125 RADIAL HEAD ALIGNMENT TEST USING SHUGART
; SA 125 TEST DISKETTE. MUST BE PROTECTED
; * (M)AP ADDRESS PRINTS OUT ALL ADDRESSES THAT RESPOND
; * (ST)ATUS TYPES CUMULATIVE TRANSFER AND ERROR
; STATUS.
; (RE)S STATUS TYPE CUMULATIVE STATUS AND CLEAR.
; (DUMPC) DUMP CIRCULAR BUFFER OF PREVIOUS PRINT-OUT
; AND ASK "RESET DUMP BUF?" (Y OR N)
; (SI)NGLE REPEATEDLY READ THE SPECIFIED SECTOR
; CHECKING STATUS.
; ASKS UNIT, TRACK, SECTOR TO BE CHECKED.

```

```

;      (T)AP      REPEATEDLY READS SPECIFIED SECTOR AS
;                  ABOVE BUT LIFTS HEAD AFTER EACH READ.

; MODE SETTING COMMANDS.

; * (SET)UNIT    ASKS UNITS (LOGICAL DRIVE #'S) TO BE
;                  OPERATED ON.  ASKS "UNIT:" EXPECTING A
;                  NUMBER <0-3> UNTIL A SPACE OR CR TYPED.
;                  ACCEPTS UNIT #'S TILL INVALID # TYPED.
;                  INITIALLY SET FOR UNITS 0 AND 1
; (SET-)TRACK    SET TRACK LIMITS FOR OPERATION
; (SEC)IN        SECTOR INCREMENT (PDP11=2, LSI-11=3)
; (I)NTRPT STT  SET INTERRUPT STATUS
;                  0 = DISABLE FLOPPY INTERRUPTS
;                  NOT 0 = ENABLE FLOPPY INTERRUPTS AND
;                  CHECK THAT AN INTERRUPT OCCURS
; (SETD)EVICE    ASKS DEVICE REGISTER TO BE CYCLED
;                  THROUGH FOR MULTI DEVICE OPERATION.
;                  STEPS TO NEXT FIELD IF SPACE.
;                  EXITS ON <CR> TO "RXCS  :"
; (SH)ORT        CHANGES ACCEPTANCE TEST LIMITS TO DO
;                  ONLY FIRST 8 TRACKS OF EACH DRIVE THEN
;                  STARTS THE ACCEPTANCE TEST
; * (V)ERIFY     DOES SHORT ACCEPTANCE TEST THEN
;                  RESETS BACK TO USE ALL TRACKS AND
;                  SCANS ALL DISKETTES OVER ALL TRACKS.
;                  IT THEN DOES A CTRL P TO INHIBIT ALL
;                  BUT ERROR PRINTOUT AND GOES TO THE
;                  ACCEPT TEST.

; FORMAT INITIALIZATION MODE.

; * (X)FORMAT REALLY?  MUST ANSWER WITH "Y TO PROCEED.
;                  ASKS "UNIT: " TO BE FORMATTED.
;                  ASKS "STANDARD FORMAT?" IF "N" ANSWER
;                  ASKS "INTERLEAVED FORMAT?"
;                  FORMATS SPECIFIED DISKETTE TO THE
;                  BLANK IBM FORMAT BY WRITING THE
;                  SOFT SECTOR SECTOR I.D. MARKS THEN
;                  WRITING THE IBM INITIAL DATA.
;                  'Y' MUST BE TYPED TO "FORMAT REALLY"
;                  AND THE DRIVE MUST BE WRITE ENABLED
;                  FOR FORMATTING TO OCCUR
;                  SEE SHUGART IBM COMPATIBILITY REF MANUAL
;                  FOR FORMAT SPECIFICS

; DUMP - COPY UTILITY MODES
; (DUP)L        DUPLICATES SOURCE UNIT ONTO DESTINATION
;                  UNIT.  ASKS "SRCUNIT", "DSTUNIT" THEN
;                  DOES A SECTOR BY SECTOR READ SRC,
;                  WRITE DST, READ DST AND COMPARE.
; (C)OMPARE     COMPARES 2 DISKETTES STARTING AT SPECI.
;                  ADDRESS.  ASKS "SRCUNIT, TRACK, SECTOR,
;                  # SECTORS, DSTUNT:"
;                  SAME AS DUPL BUT WITHOUT WRITING.
; (DUMPO)       OCTAL DUMP OF SPECIFIED SECTORS
; (DUMPB)       BYTE DUMP OF SPECIFIED SECTORS
; (DUMPA)       ASCII DUMP OF SPECIFIED SECTORS

```

```

; *****
; ERROR PRINTOUT DESCRIPTION
; *****

; ERROR FORMAT: (DEV<XXX> UN <U> TRK/SEC: <TK>/<SC> <FUNC CODE>
; RXCS=<XY> RXDB=<XY> [INTERRUPT ERROR:<X>] BAD=<XX> #GOOD=<X>
; #DATA ERRORS:<XX> ERRREG: <DEFINITIVE ERROR STATUS>

; DEV<XXX>          PRINTED ONLY WHEN RUNNING MULTIPLE SYSTEMS
;                   XXX IS LAST 3 DIGITS OF RXCS VALUE FOR SYSTEM
; UN <U>            LOGICAL DRIVE # FOR WHICH PRINTOUT OCCURRED
; TRK/SEC: <TK>/<SC> TRACK AND SECTOR ADDRESS AT WHICH
;                   PRINTOUT OCCURRED.
; FUNCT CODE        IDENTIFICATION OF THE TEST IN PROGRESS
;                   WHEN PRINTOUT OCCURRED.
; RXCS=<XY>         RXCS IS THE FLOPPY COMMAND STATUS REG AND
;                   INCLUDES ERROR FLAG 100000
;                   DONE FLAG 40
; RXDB=<XY>         DATA BUFFER REGISTER
;                   SHOULD BE 0 NORMALLY OR 214 AFTER INIT
; INTERRUPT ERROR:<X> IF < 0 INDICATES AN EXPECTED INTERRUPT
;                   DIDN'T OCCUR
;                   IF > 0 INDICATES MULTIPLE INTERRUPTS
; #BAD=<XX> #GOOD=<X> CUMULATIVE SUMMARY OF # STATUS ERRORS
;                   DETECTED AND # SECTORS TRANSFERRED OK
; #DATA ERRORS:<XX> # OF BYTE OF DATA FOUND TO NOT COMPARE
;                   WITH EXPECTED VALUE

; ERREG:<DEFINITIVE ERROR STATUS> SPECIFIC ERROR CODE FOR
;                   ERROR TYPE AS DESCRIBED 2 PAGES HENCE

; FUNCTION CODE LIST AND DESCRIPTION

; TEST CODE MEANING
; FILL-EMPTY FB PROBLEM LOADING SECTOR BUFFER.
; E1,E2 SECTOR BUFFER DATA DIDN'T CHECK DURING
; EMPTY-BUFFER OPERATION.
; SEQ. WRITE SW PROBLEM LOADING SECTOR BUFFER.
; SEQRD CW,SR DATA READ BACK WRONG
; RANDOM RW,RC,RR RANDOM (WRITE,CHECK,READ)
; ANY READ XE EMPTY BUFFER CHECK BEFORE
; RETRY RE TRYING THE READ
; DUP UTILITY IN ERROR READING SOURCE
; CW ERROR READING WHAT WAS JUST WRITTEN
; DELETED DATA DW, DR DELETED DATA FLAG FAILURE

; DATA FORMAT WRITTEN BY FRDTST IN ALL SECTORS.

; BYTE 0, 1 SECTOR #, TRACK #
; 2 - 7 6 BYTES OF ALL ONE'S
; 10 - 17 10 BYTES OF ALL ZEROES
; 20 - 21 SEED FOR RANDOM # GENERATOR
; 22 -177 RANDOM # SEQUENCE.

```

```

; *****
; FLOPPY INTERFACE REGISTERS AND DEFS.
; *****
.SBTTL INTERFACE REGISTER DEFS
  
```

177170 RXCS=177170 ; COMMAND AND STATUS REGISTER.

```

; WRITE RO IN X X X X X X RO IE UT UN FN FN FN EX
; READ ERR WO X X X X X X TR IE DN WO WO WO WO WO
; RO = READ ONLY
; WO = WRITE ONLY
; ERR= ERROR DET. (CLEARED BY COMMAND INIT
; IN = CONTROLLER INIT.
; TR = TRANSFER REQUEST.
; IE = INTERRUPT ENABLED ON DONE.
; DN = DONE FLAG.
; UT = HIGH UNIT SELECT IF THREE OR MORE DRIVES.
; UN = UNIT SELECT.
; FN = FUNCTION SELECT.
; 0= FILL BUFFER          1=READ BUFFER
; 2=WRITE SECTOR         3=READ SECTOR
; 4=NOT USED             5=READ RXDB STATUS
; 6=WRT. DELETED DATA   7=READ ERROR-REG
; EX = EXECUTE.          (SEE LIST ON NEXT PAGE)
  
```

177172 RXDB=177172 ; DATA BUFFER REGISTER.

; CONTEXT CONTROLLED BY COMMAND SEQUENCE.

; AFTER AN RXCS FUNCTION IS COMPLETE A STATUS
 IS AVAILABLE TO BE READ IN RXDB LOW BYTE.

```

; X X X X X X X X DR DD XX XX WP ID PA CRC
  
```

```

; DR = DRIVE READY - CURRENTLY SELECTED DRIVE HAS DISKETTE
; INSTALLED AND UP TO SPEED.
; DD = DELETED DATA WAS READ ON LAST SECTOR.
; WP = WRITE PROTECT ERROR.
; SETS RXCS ERR BIT.
; ID = INITIALIZE DONE.
; PA = PARITY ERROR DETECTED.
; SETS RXCS ERR
; CRC= CRC ERROR DETECTED IN DATA READ.
; SETS RXCS ERR
  
```

```

; *****
; MAPPING PHYSICAL DRIVES TO LOGICAL UNITS
; *****
  
```

```

; LOGICAL UNIT MAPPING USING SWITCHES ON FORMATTER/CONTROLLER
; PHYS DRIVE (OPEN = 0, CLOSED OR JUMPERED = 1)
; # LOCATION SWITCHES USED FOR MAPPING UNT<1> UNT<2>
; 0 RIGHT LEFT 2 SWITCHES ON LEFT DIP SW (0-0) (0-1)
; 1 MIDDLE RIGHT 2 SWITCHES ON LEFT DIP SW (1-0) (1-1)
; 2 LEFT MOST LEFT 2 SWITCHES ON RIGHT DIP SW (2-0) (2-1)
  
```

; LOGICAL DRIVE 3 IS USED TO SPECIFY A DRIVE AS NON-EXISTANT

```

;*****
.SBTTL ERRREG ERROR CODES
;*****

; ERROR CODES GIVEN BY READ ERROR-REG STATUS FUNCT (FUNCT 7)
; PRINTED AS ERRREG: XX ON ERROR PRINTOUT
; CODE LIGHT # MEANING
; 10 2 DRIVE 0 FAILED TO HOME ON INIT, OR DIDN'T SELECT
; 20 2 DRIVE 1 FAILED TO HOME ON INIT, OR DIDN'T SELECT
; 30 2 FOUND HOME WHEN STEPPING OUT 10 TRACKS FOR INIT.
; 40 2 TRACK GREATER THAN 77. OR UNIT SELECT ERROR.
; 50 2 HOME BEFORE DESIRED TRACK FOUND.
; 70 2 DESIRED SECTOR COULD NOT BE FOUND AFTER 2 REVS.
;
; 100 3 WRITE PROTECT ERROR. - SETS RXES <10>
; 110 MORE THAN 48 USEC AND NO SEPERATED CLOCK FOUND.
; 120 0 NO PREAMBLE WAS FOUND (24 BITS OF 0'S)
; 130 0 PREAMBLE FOUND BUT NO ID ADDR MARK WITHIN WINDOW
; 140 CRC ERROR ON WHAT APPEARED TO BE HEADER.
; DOESEN'T SET ERROR FLAG WHEN ENCOUNTERED.
; 150 2 HEADER TRACK ADDRESS OF A GOOD HEADER DIDN'T
; MATCH DESIRED TRACK.
; 160 0 TOO MANY TRIES FOR AN I. D. ADDRESS MARK.
; 170 0 DATA ADDRESS MARK NOT FOUND IN ALLOTTED TIME.
; 200 0 CRC ERROR ON READING SECTOR FROM DISK.
; RXES STATUS BIT OF VALUE 1 IS ALSO SET.
; 210 1 PARITY ERROR (INTERFACE <=> CONTROLLER)
; RXES STATUS BIT OF VALUE 2 IS ALSO SET.
; 220 2 DRIVE 2 FAILED TO HOME ON INIT.
; 230 2 DRIVE 3 FAILED TO HOME ON INIT.
; 240 SELECTED DRIVE NOT READY (110 ONLY)
; INDEX HOLE NOT ON TIME
; 250 0 EXPECTED HEADER NOT FOUND AFTER TRACK FORMAT.
; 260 0 INDEX MARK NOT FOUND IN EXPECTED RANGE.
; (FORMAT NOT BEGUN)
; 270 0 INDEX MARK NOT FOUND IN EXPECTED RANGE.
; (FORMAT HAS OCCURED)
; 300 DATA LOST FROM WESTERN DIGITAL 1771 TO 8048.
; (110 CONTROLLER ONLY)
;
; SOFTWARE CONDITIONS REPORTED AS STATUS ERRORS
; 177 TIMEOUT ON DONE
; 176 TIMEOUT ON TRREQ
; 1 INTERRUPT ERROR

; FRONT PANEL ERROR LIGHT DESCRIPTION
; LIGHTS MEANING
; 0 FRONT DATA TYPE ERROR
; 1 FRONT PARITY ERROR BETWEEN CONTROLLER-INTERFACE.
; 2 FRONT SEEK TYPE ERRORS
; 3 FRONT SWITCH CONFLICT ERROR OR CONTROLLER ERROR.
; INCLUDES WRITE PROTECT OR FORMAT INHIBITED
; ERROR TYPES.
; BOARD LIGHTS (210 ONLY)
; UP-LEFT CONTROLLER WAITING FOR BUS INTERFACE READY.
; UP-RGHT INIT IN PROGRESS.
; LW-LEFT READ IN PROGRESS
; LW-RGHT WRITE IN PROGRESS.

```

```

; START-RESTART ADDRESSES.
; 1104 - NORMAL START -RESTART ADDRESS.
; CAN BE STOPPED AND RESTARTED HERE AT ANY TIME.
; 1110 - START ADDRESS FROM MONITOR CALL TO SAVE VECTORS
; 1100 - RETURN ADDRESS FROM ODT AFTER CTRL D DISPATCH.
; ALSO START ADDRESS FOR ODT.
; 1114 - EMERGENCY RETURN TO "MODE" WITHOUT DOING INIT.

```

```

; FRONT END MACRO DEFS.

```

```

000040 STRTAD=40 ; START ADDRESS FOR REENTER.
000044 JBSTW=44 ; JOB STATUS WD: B7=REENTER, B12=SPECIAL TTY
000052 ERRWD=52
000054 MONLOW=54 ; ADDRESS OF BEGINNING OF RESIDENT MONITOR.

```

```

177560 TKS=177560
177562 TKB=TKS+2
177564 TPS=177564
177566 TPB=TPS+2

```

```

000000 .MCALL ..V2.., .REGDEF, .EXIT, .SRESET, .SETTOP
000000 .V2..
. REGDEF ; DEFINE REGISTERS
. ENABL AMA

. MACRO SAVE ARG1, ARG2, ARG3, ARG4, ARG5, ARG6
. IIF NB <ARG1>, MOV ARG1, -(SP)
. IIF NB <ARG2>, MOV ARG2, -(SP)
. IIF NB <ARG3>, MOV ARG3, -(SP)
. IIF NB <ARG4>, MOV ARG4, -(SP)
. IIF NB <ARG5>, MOV ARG5, -(SP)
. IIF NB <ARG6>, MOV ARG6, -(SP)
. ENDM

. MACRO RESTR ARG1, ARG2, ARG3, ARG4, ARG5, ARG6
. IIF NB <ARG6>, MOV (SP)+, ARG6
. IIF NB <ARG5>, MOV (SP)+, ARG5
. IIF NB <ARG4>, MOV (SP)+, ARG4
. IIF NB <ARG3>, MOV (SP)+, ARG3
. IIF NB <ARG2>, MOV (SP)+, ARG2
. IIF NB <ARG1>, MOV (SP)+, ARG1
. ENDM

. MACRO PRINT ASCSTR ; PRINT THE ASCII STRING
JSR R5, PRINT
. ASCIZ "ASCSTR"
. EVEN
. ENDM

. MACRO ASCIZ ASCSTR
. ASCIZ "ASCSTR"
. ENDM

. MACRO TEXTL TEXT
. ASCII "TEXT"<15><12>
. ENDM

```

8

7

6

5

4

3

2

1

ZONE		LTR		DESCRIPTION	DATE	APPROVED

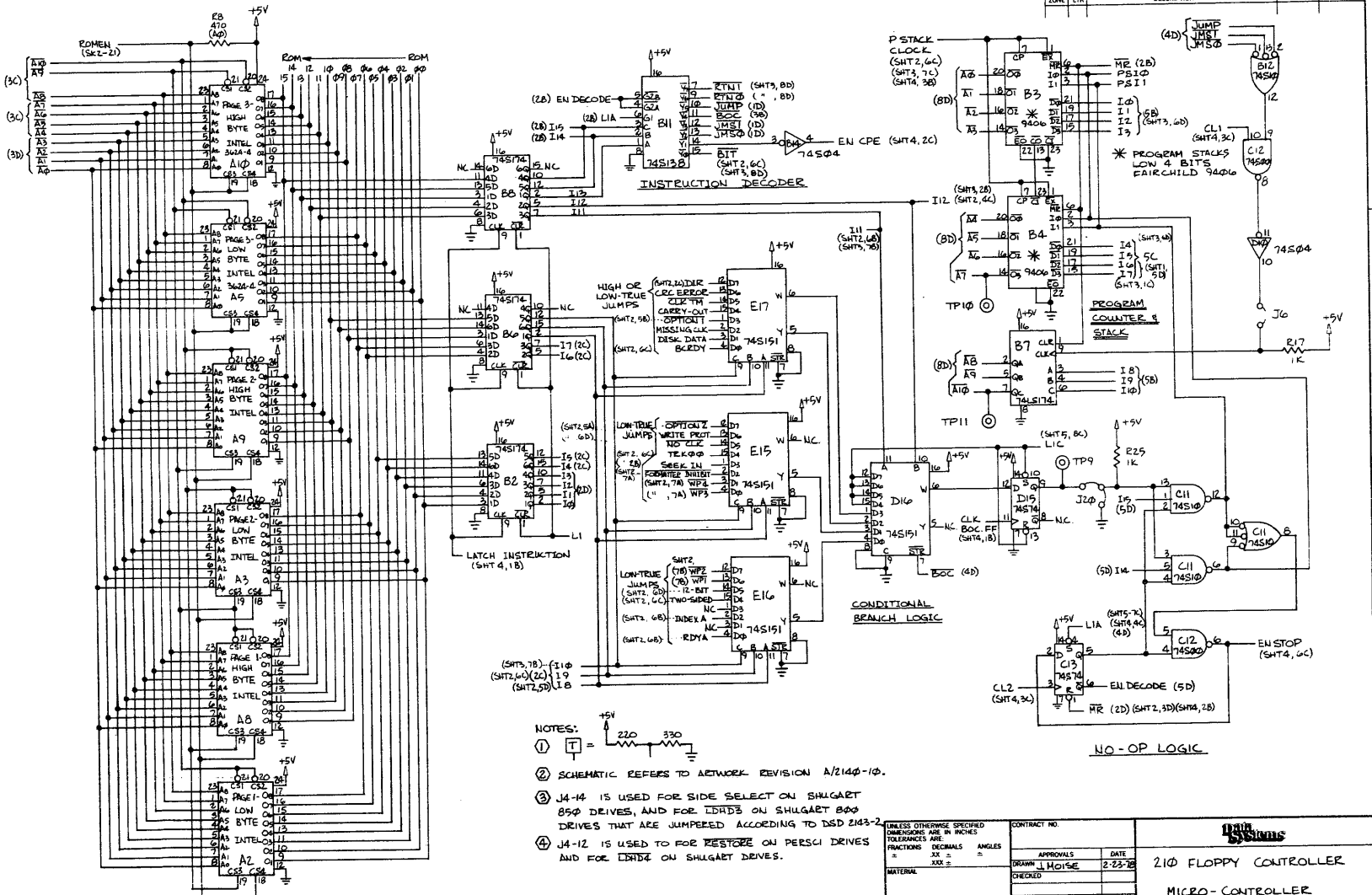

- NOTES:
- ① $\overline{T} = \frac{220}{330}$
 - ② SCHEMATIC REFERS TO NETWORK REVISION A/2140-10.
 - ③ J4-14 IS USED FOR SIDE SELECT ON SHUGART 850 DRIVES, AND FOR ID3B ON SHUGART 850 DRIVES THAT ARE JUMPERED ACCORDING TO DSD 2143-2.
 - ④ J4-12 IS USED FOR RESTORE ON PERSCI DRIVES AND FOR ID3B ON SHUGART DRIVES.

UNLESS OTHERWISE SPECIFIED DIMENSIONS ARE IN INCHES TOLERANCES ARE FRACTIONS DECIMALS ANGLES		CONTRACT NO.	
APPROVALS	DATE	210 FLOPPY CONTROLLER	
DRAWN <u>HOISE</u>	2-23-78	MICRO-CONTROLLER	
CHECKED		SIZE	CODE IDENT NO. DRAWING NO.
		D	S/2140-10A
DO NOT SCALE DRAWING		SCALE NONE	SHEET 1 OF 5

62

D

C

B

A

D

C

B

A

8

7

6

5

4

3

2

1

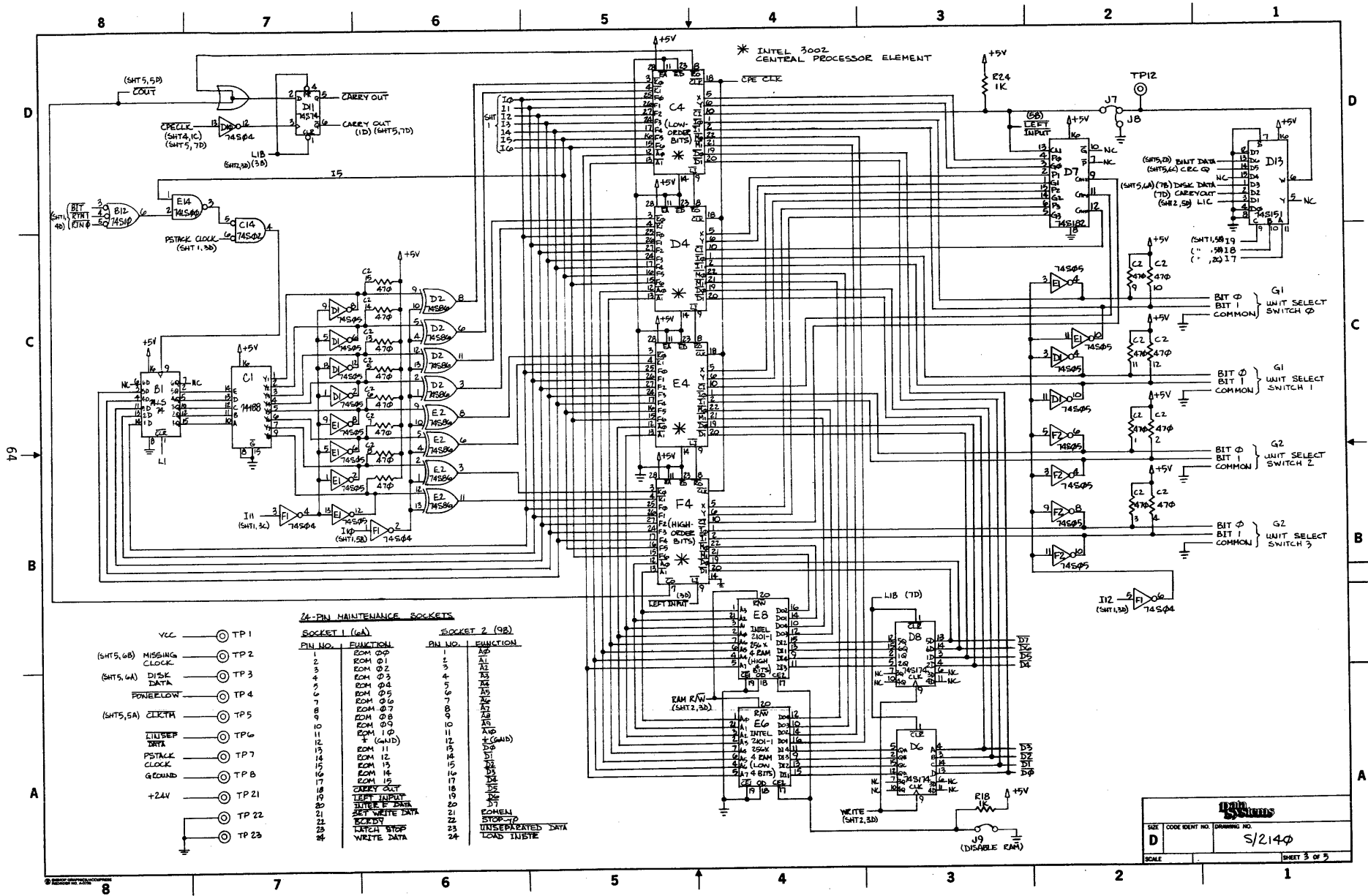

24-PIN MAINTENANCE SOCKETS

SOCKET 1 (6A)		SOCKET 2 (9B)	
PIN NO.	FUNCTION	PIN NO.	FUNCTION
1	ROM 01	1	MS
2	ROM 02	2	AI
3	ROM 03	3	AI
4	ROM 04	4	AI
5	ROM 05	5	AI
6	ROM 06	6	AI
7	ROM 07	7	AI
8	ROM 08	8	AI
9	ROM 09	9	AI
10	ROM 10	10	AI
11	ROM 11	11	AI
12	ROM 12	12	AI
13	ROM 13	13	AI
14	ROM 14	14	AI
15	ROM 15	15	AI
16	ROM 16	16	AI
17	ROM 17	17	AI
18	ROM 18	18	AI
19	ROM 19	19	AI
20	CARRY OUT	20	AI
21	LEFT INPUT	21	AI
22	WRITE DATA	22	AI
23	WRITE DATA	23	AI
24	WRITE DATA	24	AI

- YCC — TP 1
- (SHT5, 6B) MISSING CLOCK — TP 2
- (SHT5, 6A) DISK DATA — TP 3
- POWERLOW — TP 4
- (SHT5, 5A) CLKTR — TP 5
- LINEUP DATA — TP 6
- PSTACK CLOCK — TP 7
- GROUND — TP 8
- +24V — TP 21
- TP 22
- TP 23

SIZE CODE IDENT NO. DRAWING NO.

D S/2140

 SCALE SHEET 3 OF 3

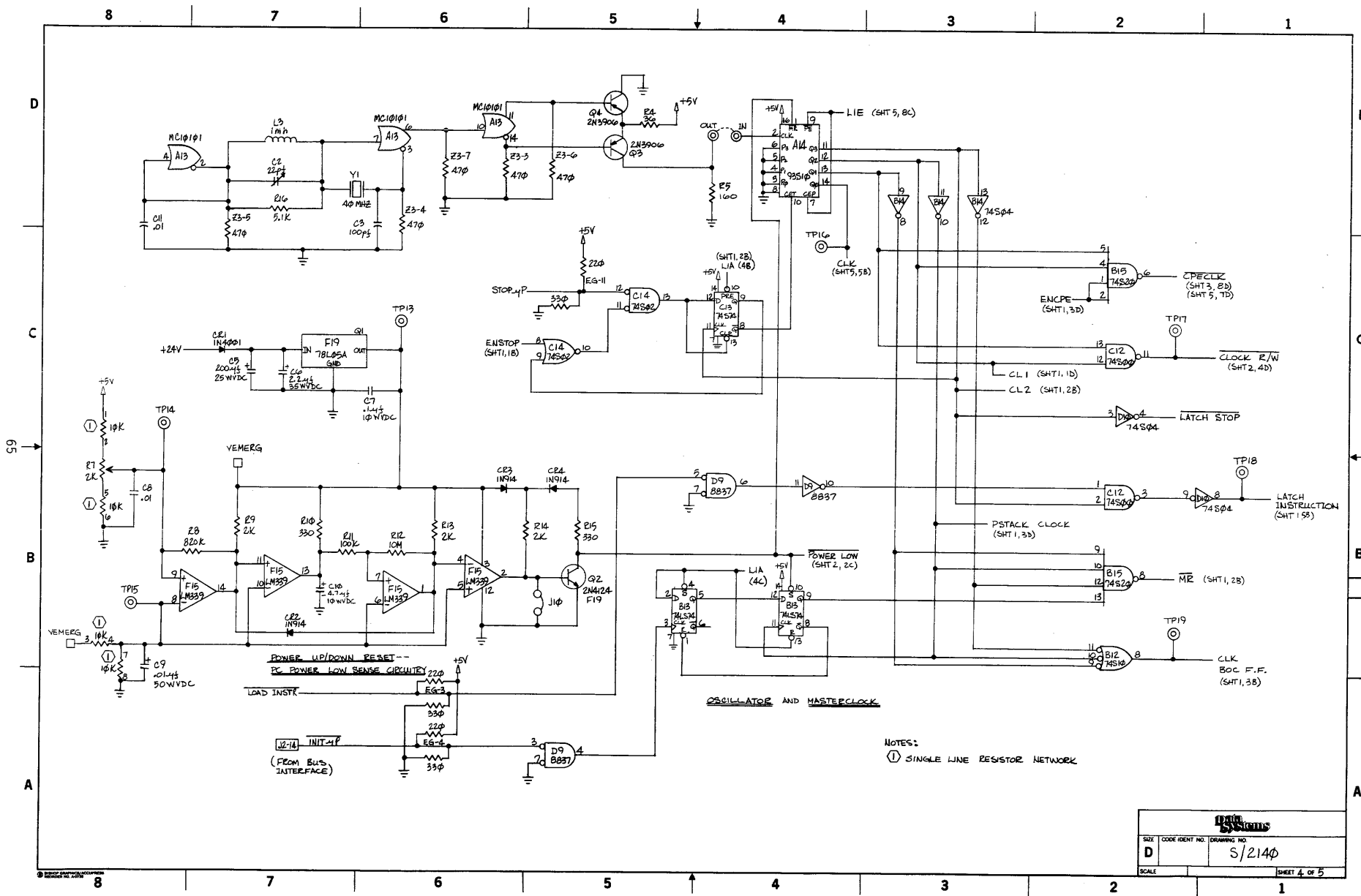

NOTES:
 ① SINGLE LINE RESISTOR NETWORK

DATA SYSTEMS	
SIZE	CODE IDENT NO. DRAWING NO.
D	S/2140
SCALE	SHEET 4 OF 5

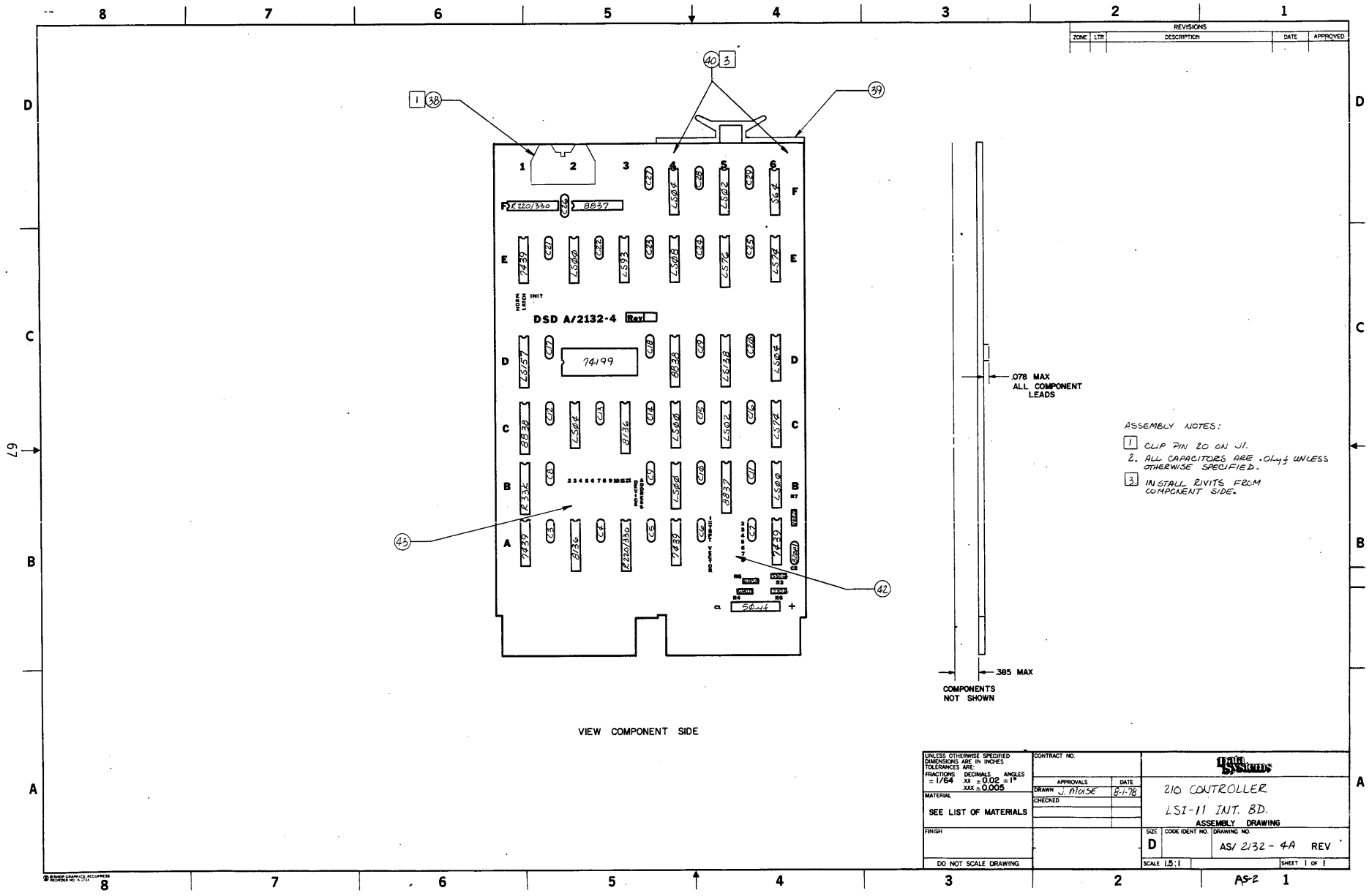

REVISIONS				
ZONE	LTR	DESCRIPTION	DATE	APPROVED

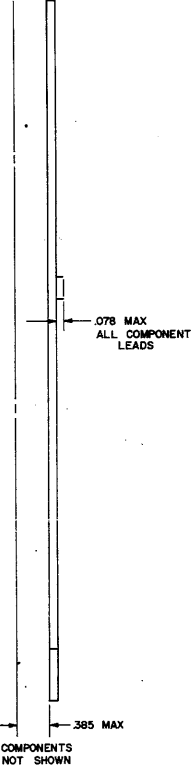
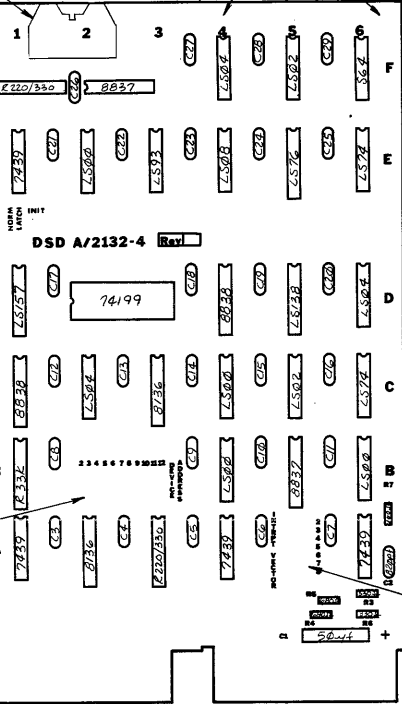

- ASSEMBLY NOTES:
- 1 CLIP PIN 20 ON J1.
 2. ALL CAPACITORS ARE .01μf UNLESS OTHERWISE SPECIFIED.
 - 3 INSTALL UNITS FROM COMPONENT SIDE.

VIEW COMPONENT SIDE

UNLESS OTHERWISE SPECIFIED DIMENSIONS ARE IN INCHES TOLERANCES ARE: FRACTIONS .10 DECIMALS .005 ANGLES .1°	CONTRACT NO.	
	APPROVALS	
MATERIAL	DRAWN J. NOISE 8-1-78	210 CONTROLLER
SEE LIST OF MATERIALS	CHECKED	LSI-11 INT. BD.
FINISH	SIZE	ASSEMBLY DRAWING
DO NOT SCALE DRAWING	CODE IDENT NO.	AS/ 2132-4A REV
	DRAWING NO.	SHEET 1 OF 1

ZONE		LTR		REVISIONS		DATE	APPROVED

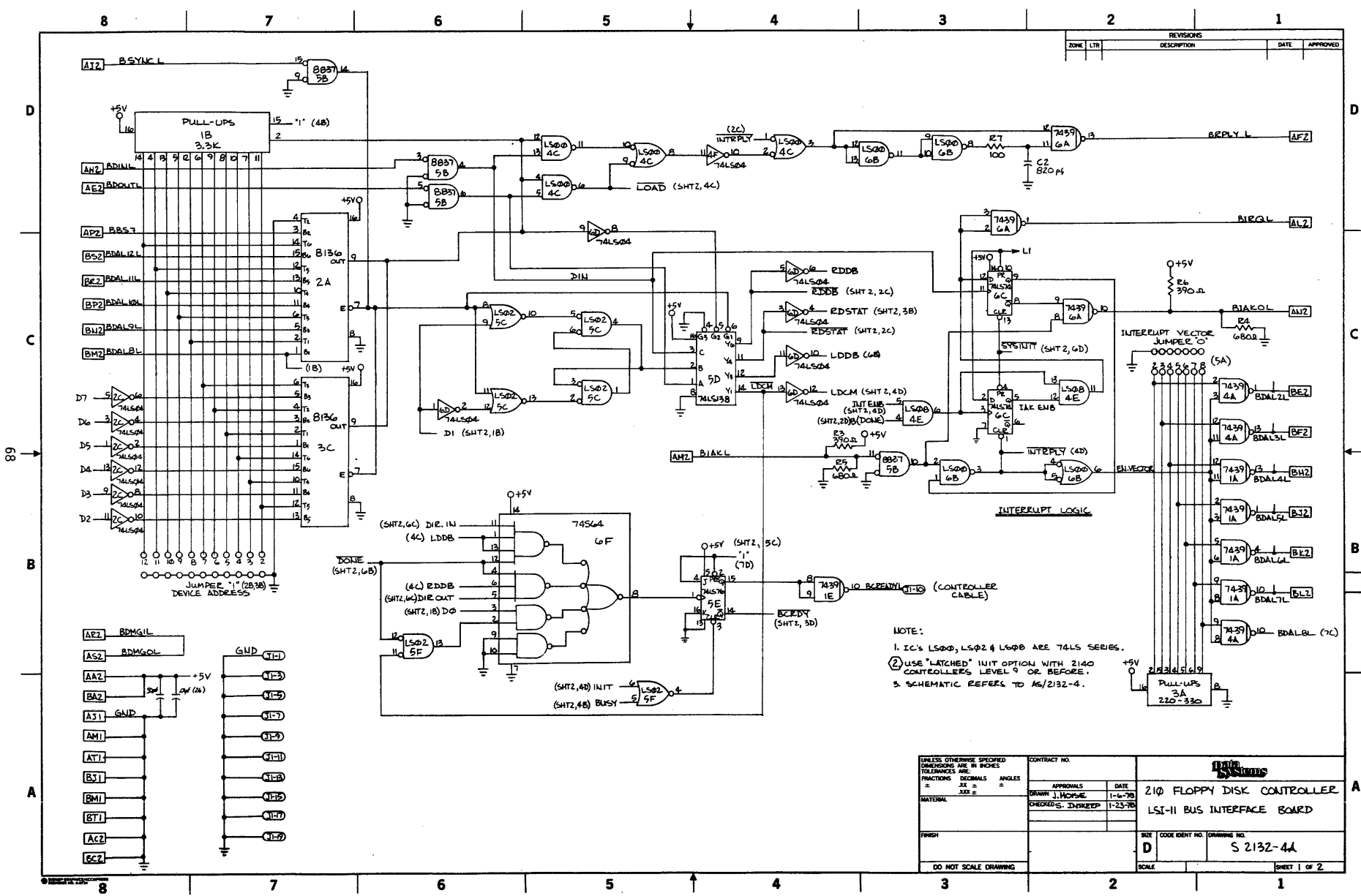

NOTE:
 1. IC's LS00, LS02 & LS04 ARE 74LS SERIES.
 2. USE "LATCHED" INIT OPTION WITH 2140 CONTROLLERS LEVEL 9 OR BEFORE.
 3. SCHEMATIC REFERS TO AS/2132-4.

UNLESS OTHERWISE SPECIFIED DIMENSIONS ARE IN INCHES		CONTRACT NO.	
TOLERANCES ARE:	FRACTIONS	DECIMALS	ANGLES
±	XX	±	±
MATERIAL	DATE	APPROVALS	
FINISH	1-6-78	DESIGN J. HOPKINS	DATE
DO NOT SCALE DRAWING	CHECKED S. INHART	1-23-78	
SCALE		CODE IDENT NO. DRAWING NO.	
SHEET 1 OF 2		S 2132-4A	

DATA Systems
 210 FLOPPY DISK CONTROLLER
 LSI-11 BUS INTERFACE BOARD
 S 2132-4A

8 7 6 5 4 3 2 1

ZONE		REVISIONS		DATE	APPROVED
LETTER	NUMBER	DESCRIPTION	DATE	APPROVED	

3

70

3

A

D

C

B

A

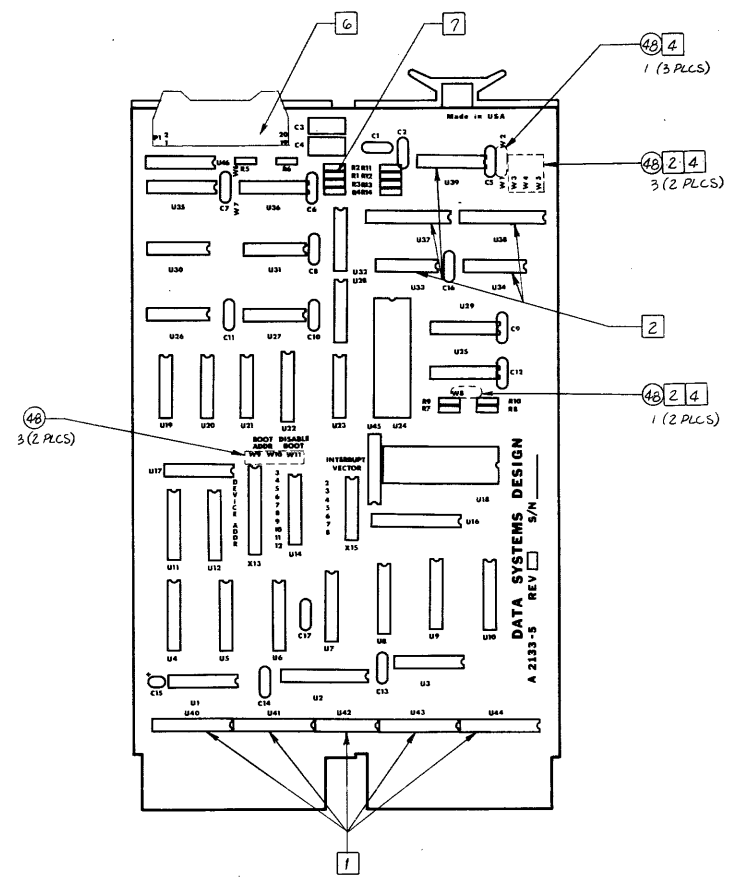

VIEW COMPONENT SIDE

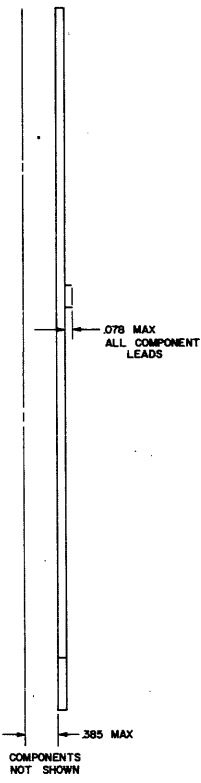

- NOTES:
- FOR BOARDS WITHOUT TERMINATORS DO NOT INSTALL U4C-U4E AND MASK Holes BEFORE WAVE SOLDERING.
 - FOR BOARDS WITHOUT REFRESH DO NOT INSTALL U33, U34, U37-U39. INSTALL JUMPER W3-W5 & W8.
 - W6 IS ALREADY INSTALLED AS A TRACE ON THE SOLDER SIDE. IF LATCHED INIT IS SPECIFIED, CUT W6 AND ADD W7.
 - FOR BOARDS WITH REFRESH INSTALL W2. DO NOT INSTALL GOLD PINS FOR W3-W5 & W8. DO NOT INSTALL R1-R14.
 - THE FOLLOWING IS A LIST OF SUB ASSEMBLIES:
 U33 - X11 NO REFRESH, NO TERMINATORS
 U34 - REFRESH, NO TERMINATORS
 U37 - NO REFRESH, 184590 TERMINATORS
 U39 - REFRESH, 184590 TERMINATORS
 - REMOVE PIN 20 ON P1 PRIOR TO ASSEMBLY.
 - DO NOT INSTALL R1.

UNLESS OTHERWISE SPECIFIED DIMENSIONS ARE IN INCHES TOLERANCES ARE: FRACTIONS DECIMALS ANGLES ± 1/64 ± 0.005 ± 1°	CONTRACT NO.		
	APPROVALS	DATE	
MATERIAL	DRAWN J. MOISE	8-1-78	210 FLOPPY DISC SYSTEM LSI-11 BUS INTERFACE ASSEMBLY DRAWING
SEE LIST OF MATERIALS	CHECKED		
FINISH	SIZE CODE IDENT NO.	DRAWING NO.	D AS/2133-5/K REV B
DO NOT SCALE DRAWING	SCALE 1.5:1	SHEET 1 OF 1	

8 7 6 5 4 3 2 1

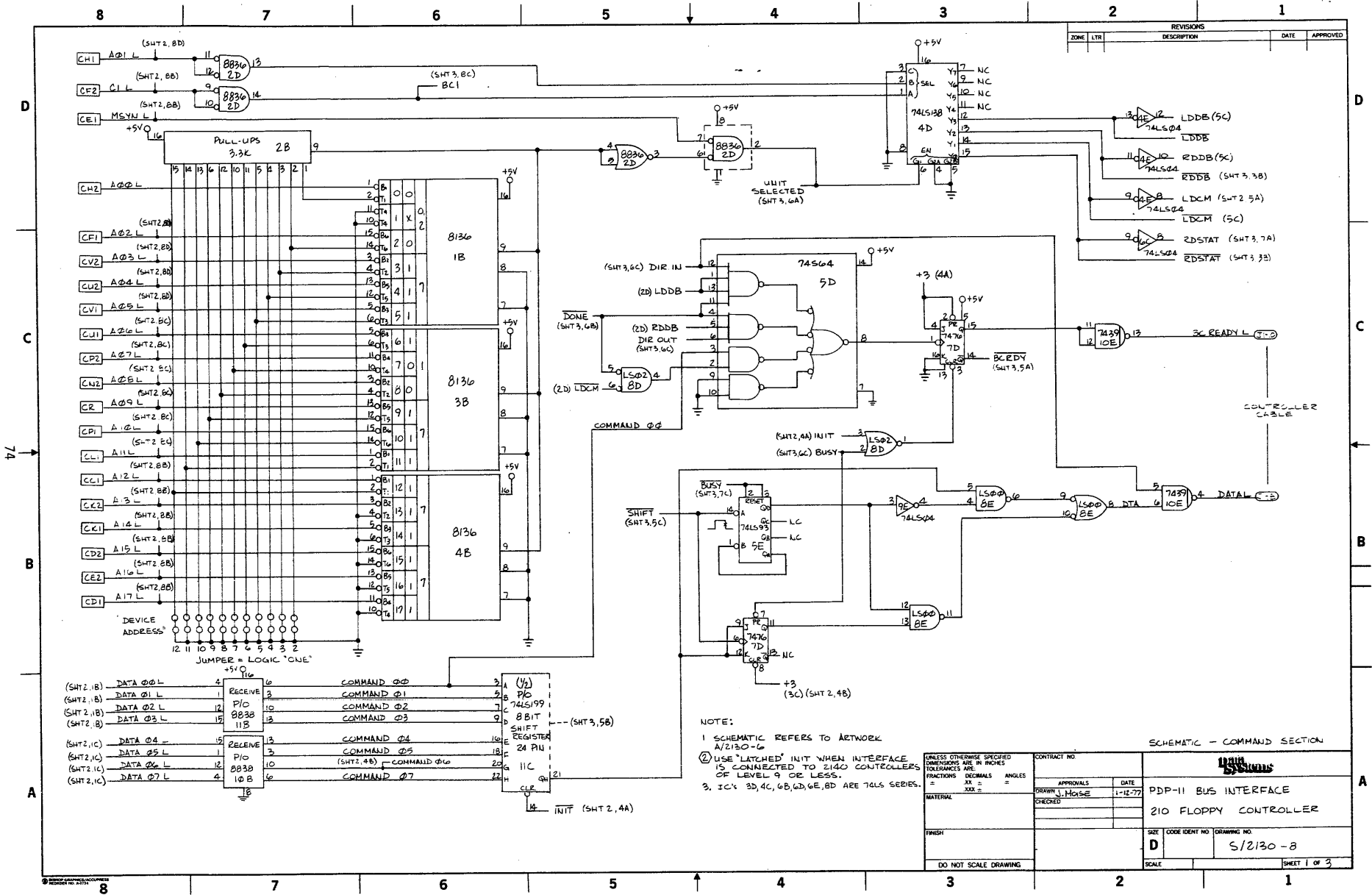



APPLICATION		REVISION			
NEXT ASSY	USED ON	LTR	DESCRIPTION	DATE	APPROVED

Description of Relative Timing Diagram

A. Fill Disk Controller Sector Buffer

1. A command is received from the computer. The high-order bit of the command appears on the bi-directional DATA line. Data is to be shifted to the disk controller because the disk controller has placed DIRECTION in the high state.
2. The computer bus interface card notifies the disk controller that it has received the command by asserting BCRDY.
3. The disk controller responds to the command by negating DONE. The disk controller also reads the high-order data bit from the DATA line.
4. The computer bus interface completes the hand-shake by negating BCRDY.
- 5-11. The disk controller board pulses SHIFT; the computer bus interface responds by shifting the next bit of the command to DATA; and the disk controller reads the data bits in and assembles the command.
12. After the eighth SHIFT pulse the computer bus interface places a parity bit (odd parity) on the DATA line. The disk controller checks the parity to make sure that the data has been received properly. A parity bit is appended to every data transfer from the computer bus interface to the disk controller. Parity is not used on transfers from the disk controller to the computer bus interface. The disk controller looks at the assembled command, finds that the command is "Fill Buffer," and asserts TRREQ.
13. The computer bus interface passes TRREQ to the computer which eventually responds by feeding the bus interface a data byte (or a 12 bit word if so desired). The computer bus interface tells the disk controller that the data is present by asserting BCRDY.
14. The disk controller and the computer bus interface handshake using TRREQ and BCRDY, and the disk controller reads the high-order data bit.
- 15-22. The disk controller board pulses SHIFT; the computer bus interface responds by shifting the next bit of data to the DATA line; and the disk controller reads the data bits in and assembles the byte.
Steps 13-15 are repeated 128 times so that an entire sector of data is transferred to the disk controller.
23. After the 128th data transfer, the disk controller begins to transmit its status back to the computer bus interface.
DIRECTION (to Bus Interface) is asserted.
- 24-31. The disk controller places data on the DATA line and pulses SHIFT to strobe the data into the interface shift register.
32. DIRECTION is reset to point to the disk controller and DONE is asserted to indicate the of the operation.

UNLESS OTHERWISE SPECIFIED DIMENSIONS ARE IN INCHES TOLERANCES ARE: FRACTIONS DECIMALS ANGLES \pm .XX \pm \pm \pm .XXX \pm	CONTRACT NO.				
	APPROVALS	DATE			
MATERIAL	DRAWN	SI	10-8-75		
	CHECKED	RHA			
FINISH			FLOPPY DISK CONTROLLER Computer Dependent Card--to--Disk Controller Interface Signal Description		
DO NOT SCALE DRAWING	SIZE	A	CODE IDENT NO.	DRAWING NO.	
				2171-3	
	SCALE			SHEET	1 OF 3

B. Empty Disk Controller Sector Buffer

- 1-11. (Identical to 1-11 of part A)
12. Parity is checked on the command and the command is decoded to be "Empty Buffer." This command requires that data be passed from the disk controller sector buffer to the computer bus interface board, so the disk controller sets DIRECTION accordingly.
13. The disk controller places the high-order data bit of the first word in its buffer onto the DATA line. The disk controller then pulses SHIFT. The computer bus interface responds by shifting the data bit into its shift register/data buffer.
- 14-20. The disk controller places the next data bit on the DATA line; the disk controller pulses SHIFT; and the computer bus interface assembles the entire word. No parity is appended. After the last bit has been shifted to the bus interface, the disk controller asserts TRREQ to signify that the transfer is complete. The computer bus interface passes TRREQ to the computer which eventually responds by reading the data byte/word into the accumulator.
- 21-22. The computer bus interface tells the disk controller that the data has been accepted by asserting BCRDY. The bus interface and the disk controller handshake using TRREQ and BCRDY. Steps 13-22 are repeated 128 times so that an entire sector of data is transferred to the computer.
- 23-32. (Identical to 23-32 of part A).

Other Miscellaneous Signals.

12-BIT MODE: This signal is asserted by the computer bus interface to indicate that all data transfers are to be 12 bits long (negation of 12-BIT MODE implies that all transfers are to be 8 bits long).

INITuP: When INITuP is asserted by the computer interface board, the disk controller halts its current operation and resets itself.

ERROR: The disk controller asserts ERROR to indicate that an error has occurred while it was executing the current command.

Data Systems		
SIZE	CODE IDENT NO.	DRAWING NO.
A		2171-3
SCALE		SHEET 2 OF 3

REVISIONS			
ZONE	LTR	DESCRIPTION	DATE

RELATIVE TIMING: FILL DISK CONTROLLER SECTOR BUFFER (UNDER PROGRAM CONTROL)

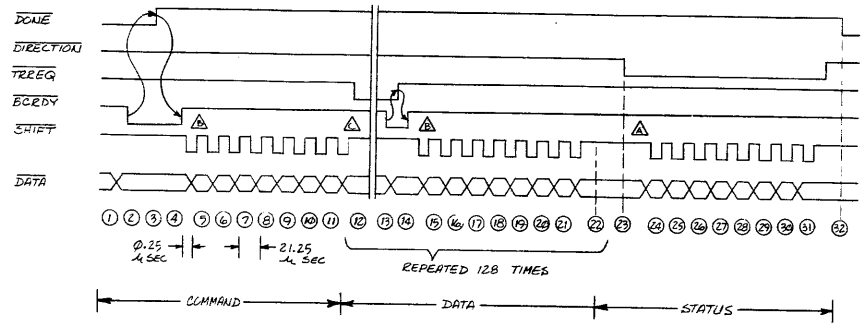

RELATIVE TIMING: EMPTY DISK CONTROLLER SECTOR BUFFER (UNDER PROGRAM CONTROL)

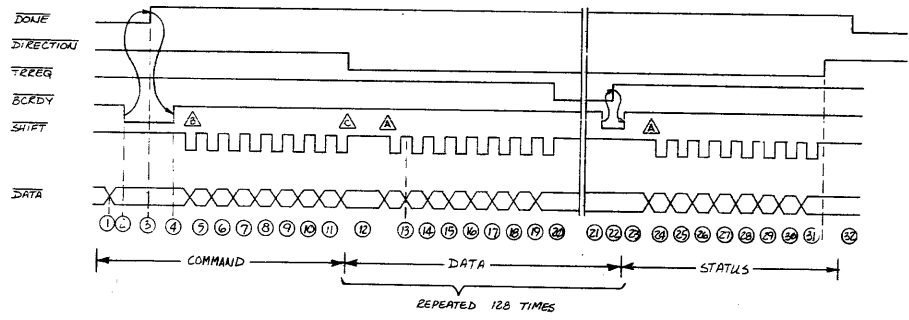

- ▲ DATA IS PRESENT 200 NS BEFORE LEADING EDGE OF SHIFT PULSE.
- ▲ INTERFACE SHOULD SHIFT DATA ON LEADING EDGE OF SHIFT PULSE.
- ▲ PARITY IS READ 2.250 NS AFTER THE TRAILING EDGE OF SHIFT PULSE.

20-CONDUCTOR INTERFACE CABLE (3M 24 304-0000 CONNECTOR)

PI/N	SOURCE	FUNCTION
1	GROUND	GROUND
2	COMPUTER CARD	12-BIT MODE (PDP-8 ONLY)
3	GROUND	GROUND
4	DISK CONTROLLER	SHIFT (DATA)
5	GROUND	GROUND
6	DISK CONTROLLER	DIRECTION (0: COMPUTER → DISK 1: DISK → COMPUTER)
7	GROUND	GROUND
8	BOTH	DATA (BI-DIRECTIONAL)
9	GROUND	GROUND
10	COMPUTER CARD	BCRDY (COMPUTER BUS CARD READY)
11	GROUND	GROUND
12	DISK CONTROLLER	TREQ (TRANSFER REQUEST)
13	GROUND	GROUND
14	COMPUTER CARD	INIT/FP (INITIALIZE MICRO-CONTROLLER)
15	GROUND	GROUND
16	DISK CONTROLLER	DONE
17	GROUND	GROUND
18	DISK CONTROLLER	FEEDR
19	GROUND	GROUND
20	GROUND	GROUND

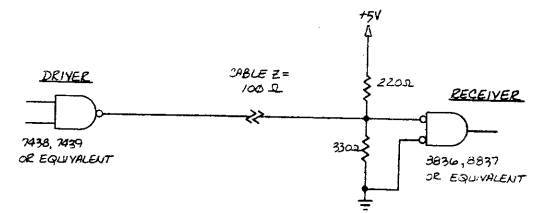

UNLESS OTHERWISE SPECIFIED DIMENSIONS ARE IN INCHES FRACTIONS DECIMALS ANGLES 1/16 1/32 1/64 1/8 1/4 3/8 1/2 3/4 1 1 1/4 1 1/2 1 3/4 2 2 1/4 2 1/2 3 3 1/4 3 1/2 4 4 1/4 4 1/2 5 5 1/4 5 1/2 6 6 1/4 6 1/2 7 7 1/4 7 1/2 8 8 1/4 8 1/2 9 9 1/4 9 1/2 10 10 1/4 10 1/2 11 11 1/4 11 1/2 12 12 1/4 12 1/2 14 14 1/4 14 1/2 16 16 1/4 16 1/2 18 18 1/4 18 1/2 20 20 1/4 20 1/2 22 22 1/4 22 1/2 24 24 1/4 24 1/2 26 26 1/4 26 1/2 28 28 1/4 28 1/2 30 30 1/4 30 1/2 32 32 1/4 32 1/2 34 34 1/4 34 1/2 36 36 1/4 36 1/2 38 38 1/4 38 1/2 40 40 1/4 40 1/2 42 42 1/4 42 1/2 44 44 1/4 44 1/2 46 46 1/4 46 1/2 48 48 1/4 48 1/2 50 50 1/4 50 1/2 52 52 1/4 52 1/2 54 54 1/4 54 1/2 56 56 1/4 56 1/2 58 58 1/4 58 1/2 60 60 1/4 60 1/2 62 62 1/4 62 1/2 64 64 1/4 64 1/2 66 66 1/4 66 1/2 68 68 1/4 68 1/2 70 70 1/4 70 1/2 72 72 1/4 72 1/2 74 74 1/4 74 1/2 76 76 1/4 76 1/2 78 78 1/4 78 1/2 80 80 1/4 80 1/2 82 82 1/4 82 1/2 84 84 1/4 84 1/2 86 86 1/4 86 1/2 88 88 1/4 88 1/2 90 90 1/4 90 1/2 92 92 1/4 92 1/2 94 94 1/4 94 1/2 96 96 1/4 96 1/2 98 98 1/4 98 1/2 100 100 1/4 100 1/2	CONTRACT NO.		
	MATERIAL		APPROVALS
FINISH	DO NOT SCALE DRAWING	210 FLOPPY DISK CONTROLLER	2/11/78
		INTERFACE CABLE SIGNAL DESC.	8/24/78
		SIZE CODE IDENT NO. DRAWING NO.	
		D	2171-3
		SCALE	SHEET 2 OF 3

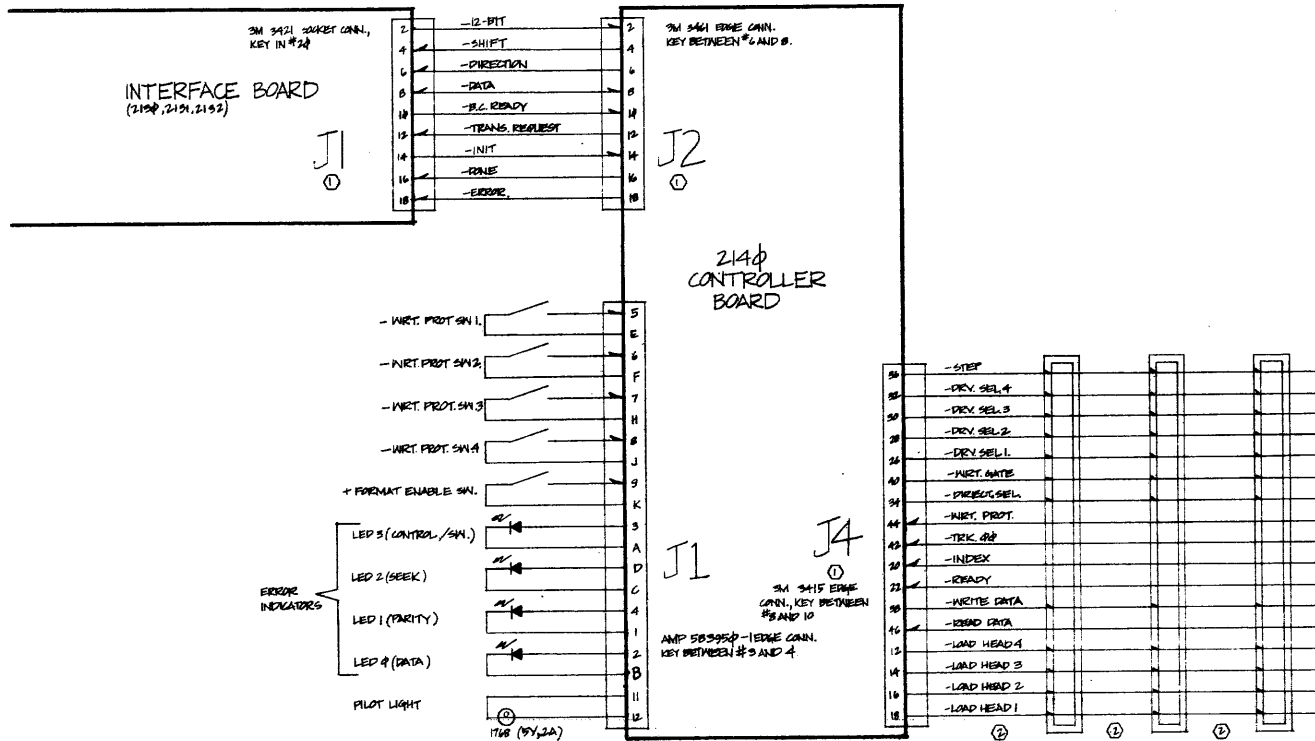

NOTES: ② DSO 2144 (MODIFIED 2144/ART 800 DRIVE)
 ① ALL ODD NO. PINS GROUNDING.

DATA SYSTEMS DESIGN		
SCALE: 1:1	APPROVED BY:	DRAWN BY: JIN
DATE: 14 DEC 76	REVIEWED:	
210 FLOPPY CONTROLLER		1 OF 1
C SIGNAL CABLE SCHEMATIC		3/2171-2

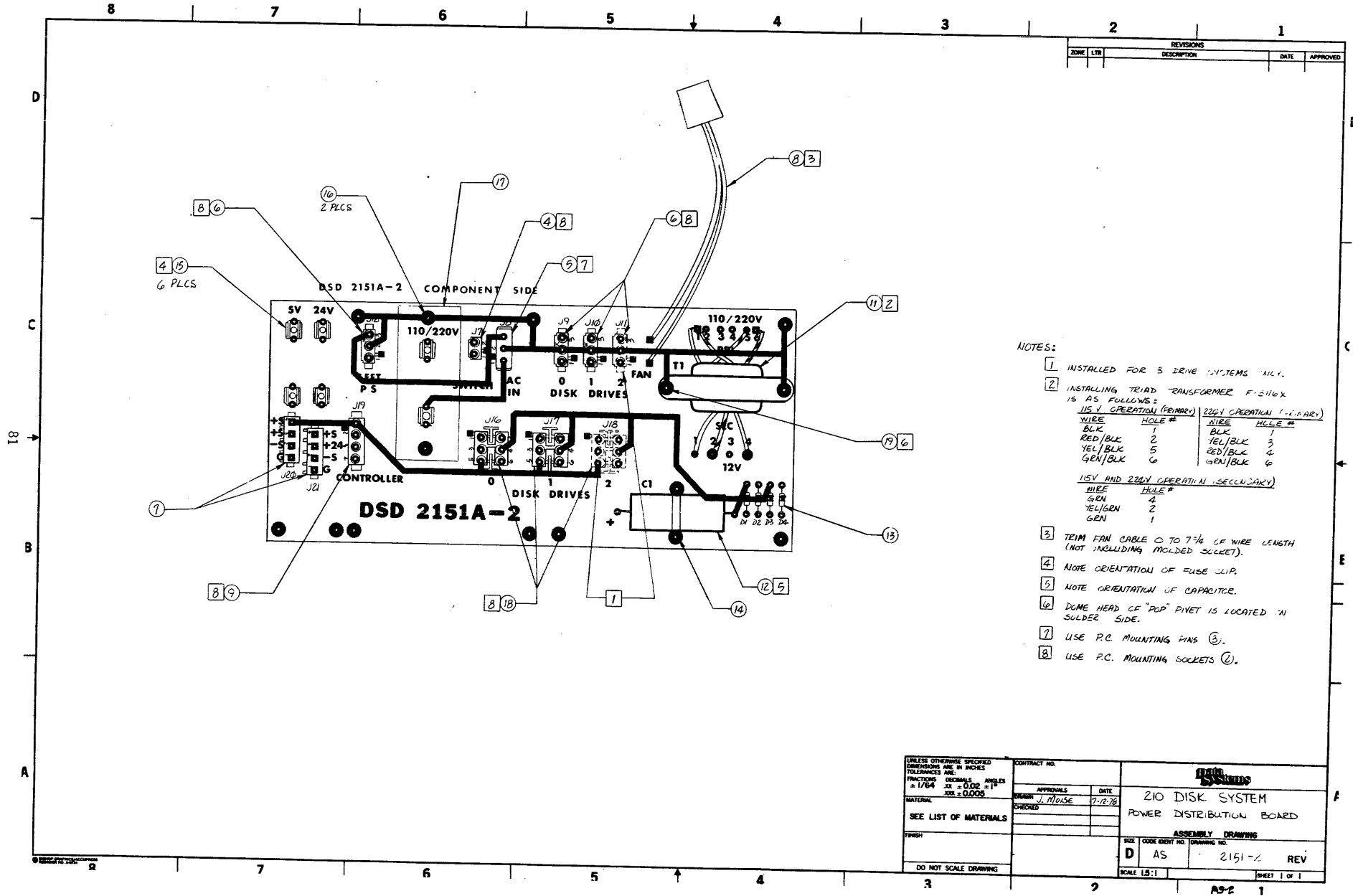

ZONE		REVISIONS	
LTR	DESCRIPTION	DATE	APPROVED

NOTES:

- 1 INSTALLED FOR 3 DRIVE SYSTEMS ONLY.
- 2 INSTALLING TRIAD TRANSFORMER F-2116X IS AS FOLLOWS:

WIRE	HOLE #	WIRE	HOLE #
BLK	1	BLK	1
RED/BLK	2	YEL/BLK	3
YEL/BLK	5	RED/BLK	4
GEN/BLK	6	GEN/BLK	6
- 3 TRIM FAN CABLE 0 TO 7/8 OF WIRE LENGTH (NOT INCLUDING MOLDED SOCKET).
- 4 NOTE ORIENTATION OF FUSE SLIP.
- 5 NOTE ORIENTATION OF CAPACITOR.
- 6 DOME HEAD OF "POP" PINLET IS LOCATED IN SOLDER SIDE.
- 7 USE P.C. MOUNTING PINS (8).
- 8 USE P.C. MOUNTING SOCKETS (9).

UNLESS OTHERWISE SPECIFIED DIMENSIONS ARE IN INCHES TOLERANCES ARE: FRACTIONS DECIMALS ANGLES ± 1/64 ± 0.002 ± 1° XSL ± 0.0005	CONTRACT NO.		
	APPROVALS	DATE	
MATERIAL	DRAWN J. MOISE	7-12-78	ASSEMBLY DRAWING
SEE LIST OF MATERIALS	CHECKED		D AS 2151A-2 REV
FINISH			SCALE 1:1 SHEET 1 OF 1
DO NOT SCALE DRAWING			

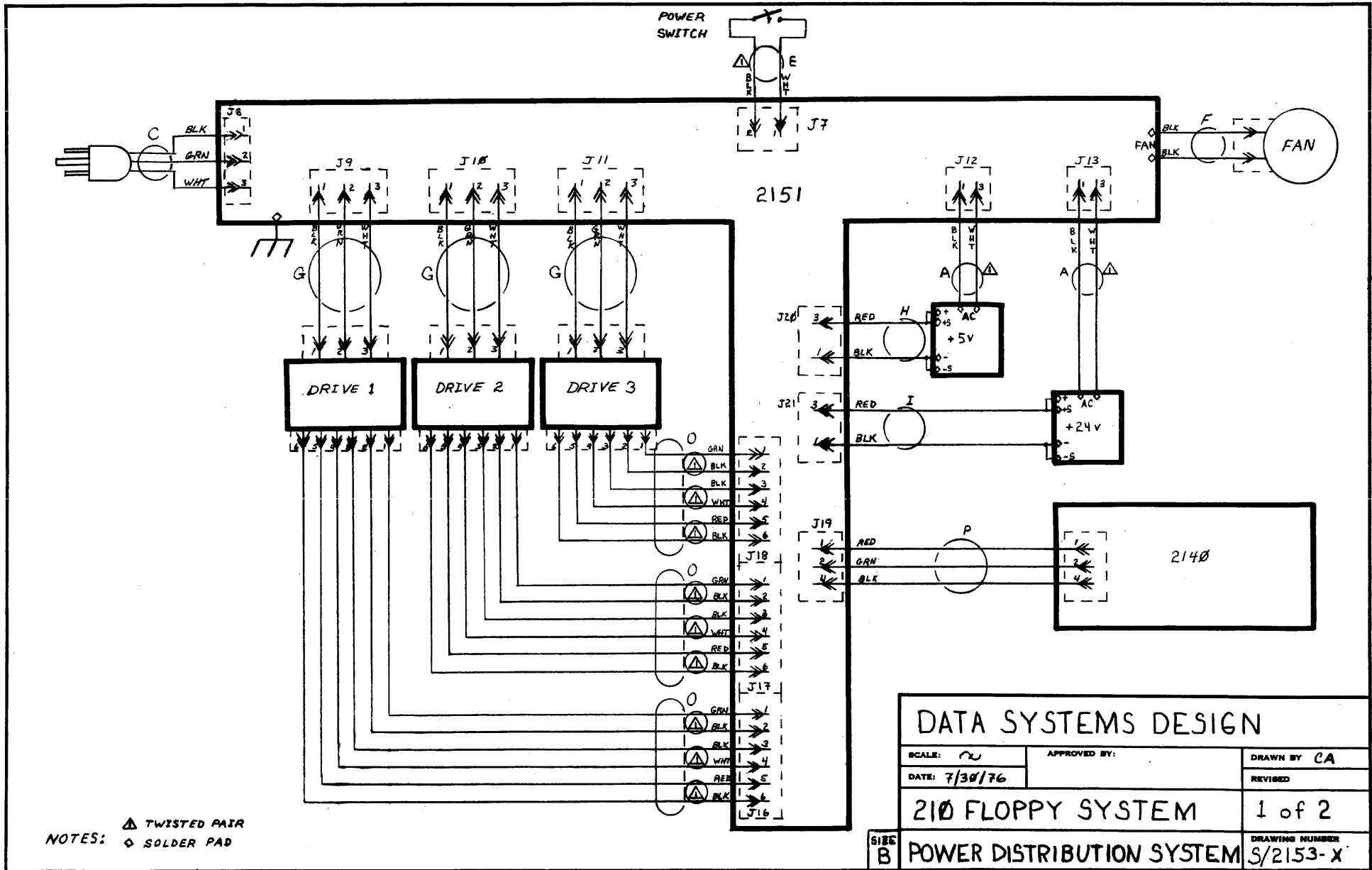

DATA SYSTEMS DESIGN		
SCALE: ~	APPROVED BY:	DRAWN BY CA
DATE: 7/30/76		REVISED
210 FLOPPY SYSTEM		1 of 2
SIB B	POWER DISTRIBUTION SYSTEM	DRAWING NUMBER S/2153-X

DSD 210-8

SOFTWARE DOCUMENTATION

The source listing for the following documentation is contained on the boot diskette, included with the manual.

VEP210 definitions and command descriptions from the listing are given on the pages following.

Directory of Software for DSD 210-8

- 1) Minimal OS/8 Bootstrap
FB00T.PA, FB00T.SV
- 2) Quick Load Format Bootstrap for TTY Reader
QUICKF.PA
- 3) DSD High Reliability (Error Dumping) Non-SYS Handler
XHR21N.PA. XHR21N.BN
- 4) DSD 210-8 System OS/8 Driver
XR01S.PA. XR01S.BN
- 5) DSD 210-8 3 Drive Non-System Handler
XR01N.PA. XR01N. BN
- 6) DSD 210-8 High Density Drive 1 Handler (HDX:)
X21HDN.PA
- 7) VEP 210 Floppy Disk Exerciser and Format Program
VEP210.PA. VEP210.SV

/VEP210 FLOPPY DISK EXORCISER 16-JUN-77
*631 / GENERALIZED STATUS ACCUMULATION, HANDLER SPEEDUP.

/ START ADDRESS IS 0200
/ TYPES ID, ASKS "DRIVE #'S"
/ OPERATOR SHOULD RESPOND WITH DESIRED DRIVE #'S "012<CR>"
/RESTART ADDRESS IS 0201
/ TYPES LIST OF OPTIONS : "A, B, F, S, R, V OR D"
/ OPERATOR TYPES KEY LETTER TO SELECT DESIRED OPTION

/ (A) ACCEPTANCE TEST - DOES SET-TEST ERROR FLAGS, (B)UFFER TEST
/ (S)EQUENTIAL WRT/READ
/ (R)ANDOM WRT/READ, AND (S)EQ READ ONLY-TESTS
/ (B) BUFFER FILL-EMPTY TEST - FILLS, EMPTIES, CHECKS SECTOR BUF
/ CHECKS COMPUTER<=>CONTROLLER DATA PATH
/ TYPES "F E FBEB" BEFORE STARTING SUBTEST.
/ (S) SEQUENTIAL WRITE/READ
/ TYPES "W" OR "R" BEFORE WRITE OR READ PASS BEGINS
/ (R) RANDOM WRITE/READ
/ TYPES "*" TO INDICATE IN RANDOM MODE
/ (D) SET UP DEVICE CODE(S) USER TYPES IN 3 DIGIT DEVICE CODE
/ EX. FOR DEVICE 76 TYPE "760 " <SPACE TERMINATOR>
/ PROGRAM RETURNS WITH NEXT ENTRY, USER TYPES <CR>
/ FOR MULTIPLE SYSTEMS TYPE DESIRED CODES
/ AND TERMINATE WITH A CR TO DEVICE: 0
/ AFTER LAST DESIRED CODE.
/ THE LOW DIGIT TYPED E.G. 3 IN 753 OVERRIDES
/ THE INITIAL DRIVE # VALUES TYPED IN IF IT IS
/ NOT ZERO. 751= SINGLE DRIVE, 752 = DUAL DRIVE
/ AND 753 = 3 DRIVE.
/ TYPING SPACE ALLOWS EXAMINATION WITHOUT MODIFYING

/ (V) VERIFY ALL SYSTEMS FUNCTIONAL. DOES SHORT (A) THEN GOES
/ AND DOES A FULL LENGTH (A) ON ALL SELECTED UNITS.

/ (F) FORMAT DISKETTE: ASKS "FORMAT UNIT #:"
/ OPERATOR TYPES DESIRED DRIVE # AND <CR>.
/ ASKS "SEQUENTIAL FORMAT?" RESPOND WITH "Y" FOR
/ STANDARD SEQUENTIAL FORMAT, "N" FOR 4 WAY INTER-
/ LEAVED FORMAT FOR SLOWER PROCESSORS.

/ (CTRL T) TYPES TOTAL SYSTEM STATUS OF ALL SYSTEMS, DRIVES.

/ (W) OPEN SOFTWARE SWITCH REGISTER FOR MODIFICATION.
/ ANY NON-ZERO VALUE ENTERED SUPERCEDES VALUE IN
/ FRONT PANEL SWITCHES.

/SWITCH 0 UP SUPPRESSES PRINTING OF ERROR MESSAGES
/SWITCH 1 UP SUPPRESSES USE OF INTERRUPT BY DRIVER.
/ ALSO DISABLES INTERRUPT RELATED ERROR CHECKS.
/SWITCH 2 UP SUPPRESSES PRINTING OF HARDWARE STATUS ERRORS
/SWITCH 5 UP INHIBITS CYCLING WHEN MULTIPLE SYSTEMS ARE SELECTED
/ USING "D. THE PROGRAM IS THEN FROZEN AT THE CURRENT DEVICE
/SWITCH 8 UP USES SEQUENTIALLY INCREMENTING DATA
/SWITCH 9 UP USES CONSTANT DATA (PRIORITY OVER 8)
/SWITCH 10 UP ALLOWS PRINT OF ALL COMPARE ERRORS

/SWITCH 11 UP ENABLES READ ONLY MODE

/SWITCHES 3-4 AND 6-7 NOT USED

/

/CONTROL C RETURN TO MONITOR (7605)
/CONTROL D INTERRUPT DISPATCH TO 200
/CONTROL R INTERRUPT DISPATCH TO 201
/CONTROL I INTERRUPT INIT THEN RESTART
/CONTROL K INTERRUPT DISPATCH TO KPAK
(R DOES INVISIBLE RETURN)
/CONTROL T TYPE CUMMULATIVE STATUS: CONTINUE
/ A ACCEPTANCE TEST (DOES B,S,R)
/ B BUFFER FILL - EMPTY TEST
/ ALSO CHECKS THAT ERROR FLAG CAN BE SET
/ F FORMAT SELECTED DISKETTE.
/ S SEQUENTIAL TEST
/ R RANDOM TEST
/ D SET DEVICE CODES.

/

/ USEFUL PARAMETER - VARIABLE LOCATIONS.

/

/ 021 BLKLIM: HIGHEST BLOCK TESTED
/ 022 NUMSCT: # PAGES TRANSFERRED EACH FLOPPY CALL
/ 025 PRNTER: # ERRORS PRINTED EACH SECTOR.
/ 063 MAXERR: MAX # ERROR LINES PRINTED BEFORE INHIBIT
/ 064 BUFPT: POINTER TO DATA BUFFER
/ 1400-1403 FIRST BLOCKS FOR UNITS 0-3
/ 1404-1407 LAST BLOCKS FOR UNITS 0-3
/ 142 DATA1: FIXED DATA, USED WHEN SW9=1
/ 143 DATA2: DATA STORED PREVIOUS TO READ
/ 144 N: OFFSET DATA, USED WHEN SW8=1
/ 200 START: START OF VEP (ASKS LOGICAL DISK NO. 'S')
RESETS ALL STATUS COUNTS
/ 201 CONT: RESTART ADDRESS (ASKS "A,B,F,S,R,D OR V")

/

/ ERROR HALT LOCATIONS AND MEANINGS

/ 457, 466, 471, 474, 477 UNEXPECTED DISK INTERRUPT
/ 501 UN IDENTIFIED INTERRUPT

SA2000=CLA STL RTR
SA4000=CLA STL RAR
SA1=CLA IAC
SA2=CLA STL RTL
SA3= CLA STL IAC RAL
SA4=CLA CLL IAC RTL
SAM2=7344
SAM3=7346
INITS= JMS I IINITS
SDNFS= JMS I ISDNFS
X0=10
X1=11
X2=12
X3=13
X4=14

/ DEFS FOR FIELD 1 MULTI DEVICE STATUS AND BUFFER ALLOCATION

NUMDEV=4 / MAX # DEVICES RUNNABLE
NUMDRV=3 / MAX # DRIVES EACH DEVICE
STLDRV=40 / # WORDS ALLOCATED FOR STATUS ACCUM EACH DRIVE
RTOTL=0 / OFFSET INTO DEV-DRV STATUS
WTOTL=2 / OFFSET FOR # WRITES INTO DEV-DRV STATUS
CETOTL=4 / OFFSET FOR # COMPARISON ERRORS DETECTED.
HETOTL=6 / OFFSET FOR # HARDWARE ERRORS DETECTED.
STTOTL=10
STLDEV=140 / STATUS LENGTH FOR EACH DEVICE
STTBUF=1000 / 0-STTBUF = CIRC DUMP BUFFER
/ MUST HAVE ONLY 1 BIT SET IN ADDRESS.
STTBFL=STTBUF+600 / MAXDRV*STLDRV*NUMDEV+STTBUF
DATBUF=3600 / ALLOWS 20(8) PAGE TRANSFERS BEFORE WIPING OUT OS8

PRINT= JMS I PTEXTX /PRINT A TEXT STRING
PRNT2C= JMS I IPRN2C /PRINT 2 CHARS FOLLOWING CALL.
PRNT0= JMS I POCTX /PRINT AC IN OCTAL
PRINTO= PRNT0
PRNTCR= JMS I PCRLFX /PRINT A CR AND LF

/ FLOPPY DISK INTERFACE OPERATION FOR DSD 210-8
/ DEFS FOR INTERFACE OPERATION.

LCDR=6751 / LOAD COMMAND REG: CLEAR AC.

/ XX XX XX XX MA SZ DH DR FN FN FN XX
/ MA = 1 FOR MAINTAINANCE MODE.
/ SZ = DATA WORD SIZE: 0=>12 BITS, 1=>8 BITS.
/ DH = HIGH DRIVE SELECT IF 3 DRIVES.
/ DR = DRIVE SELECT. 0=>DRIVE 0, 1=>DRIVE 1
/ FN = FUNCTION (0 - 7)
/ 0=FILL BUFFER: GET 64 12 BIT WDS OR 128 8 BIT WDS
/ 1=EMPTY BUFFER(VERIFIES DATA: DOESEN'T CHANGE BUF)
/ 2=WRITE SECTOR 3 = READ SECTOR
/ 4= NOP 5 = READ STATUS (.25 SEC) SEE XDR BIT DEF
/ 6= WRITE DELETED DATA SECTOR
/ 7= READ ERROR REG: SEE PAGE 3 ERROR CODES.

XDR=6752 / TRANSFER DATA REGISTER: BIDIRECTIONAL.
/ IF READ JAMS DATA INTO AC
/ IF WRITE LOADS FROM AC, AC UNCHANGED.
/ AC4= DRIVE READY
/ AC5= DELETED DATA MARK DETECTED IN ID
/ AC9= INITIALIZE COMPLETE.
/ AC10=PARITY ERROR ON CONTROL INF.
/ AC11=CRC ERROR DETECTED IN DATA.
/ NOTE: AFTER A LCD COMMAND FINISHED STATUS IS AVAILABLE.

/ XX XX XX XX DR DD XX XX WP ID PA CRC

/ DR =1 DRIVE READY - SELECTED UNIT READY AND UP TO SPEED
/ DD =1 DELETED DATA WAS READ BY LAST LCD COMMAND.
/ WP =1 (LCD 5 ONLY) DISKETTE IS WRITE PROTECTED.
/ ID =1 INITIALIZE DONE - SET AFTER INIT OR POWER FAIL
/ PA =1 PARITY ERROR
/ CRC=1 CRC ERROR DETECTED ON DATA READ.

STRF=6753 / SKIP ON TRANSFER REQUEST.
/ AN XDR INSTRUCTION IS DESIRED.

SERF=6754 / SKIP ON ERROR FLAGS SET.
/ DONE FLAG ALSO SET WHEN TRUE.

SDNF=6755 / SKIP ON DONE FLAG SET AND CLEAR DONE.
/ ATTACHED TO INTERRUPT LINE.

SINTR=6756 / SET INTERRUPT STATE
/ AC11=1 ENABLES INTERRUPT ON DONE FLAG SET.
/ AC11=0 DISABLES FLOPPY INTERRUPT.

INIT=6757 / INIT THE FLOPPY CONTROLLER - INTERFACE.

/ ERROR CODES GIVEN BY READ ERROR REGISTER FUNCT (MODE 7)

CODE	LIGHT #	MEANING
/ 10	2	DRIVE 0 FAILED TO HOME ON INIT OR DIDN'T SELECT
/ 20	2	DRIVE 1 FAILED TO HOME ON INIT OR DIDN'T SELECT
/ 30	2	FOUND HOME WHEN STEPPING OUT 10 TRACKS FOR INIT.
/ 40	2	TRACK GREATER THAN 77. OR UNIT SELECT ERROR.
/ 50	2	HOME BEFORE DESIRED TRACK FOUND.
/ 70	2	DESIRED SECTOR COULD NOT BE FOUND AFTER 2 REVS.
/		
/ 100	3	WRITE PROTECT ERROR.
/ 110		MORE THAN 40 USEC AND NO SEPERATED CLOCK FOUND.
/ 120	0	NO PREAMBLE WAS FOUND (24 BITS OF 0'S)
/ 130	0	PREAMBLE FOUND BUT NO I/O MARK WITHIN WINDOW.
/ 140	0	CRC ERROR ON WHAT APPEARED TO BE HEADER.
/ 150	2	HEADER TRACK ADDRESS OF A GOOD HEADER DIDN'T MATCH DESIRED TRACK.
/		
/ 160	0	TOO MANY TRIES FOR AN I. D. ADDRESS MARK.
/ 170	0	DATA ADDRESS MARK NOT FOUND IN ALLOTTED TIME.
/ 200	0	CRC ERROR ON READING SECTOR FROM DISK.
/		RXES STATUS BIT 11 ALSO SET.
/ 210	1	PARITY ERROR (INTERFACE <=> CONTROLLER)
/		RXES STATUS BIT 10 ALSO SET.
/ 220	2	DRIVE 2 FAILED TO HOME ON INIT.
/ 230	2	DRIVE 3 FAILED TO HOME ON INIT.
/ 240	3	FORMATTER ENABLE ERROR.
/ 250	0	EXPECTED HEADER NOT FOUND AFTER TRACK FORMAT.
/ 260	0	INDEX MARK NOT FOUND IN EXPECTED RANGE.
/		(FORMAT NOT BEGUN)
/ 270	0	INDEX MARK NOT FOUND IN EXPECTED RANGE.
/		(FORMAT HAS OCCURED)

LIGHTS	MEANING
/ 0	FRONT DATA TYPE ERROR
/ 1	FRONT PARITY ERROR BETWEEN CONTROLLER-INTERFACE.
/ 2	FRONT SEEK TYPE ERRORS
/ 3	FRONT SWITCH CONFLICT ERROR OR CONTROLLER ERROR.
/	INCLUDES WRITE PROTECT OR FORMAT INHIBIT ERRORS.
/	BOARD LIGHTS
/ 4	UP-LEFT CONTROLLER WAITING FOR BUS INTERFACE READY.
/ 5	UP-RGHT INIT IN PROGRESS.
/ 6	LW-LEFT READ IN PROGRESS
/ 7	LW-RGHT WRITE IN PROGRESS.

DSD 210-8 FLOPPY DISK DIAGNOSTIC (VEP210)

VEP210 is a comprehensive floppy disk diagnostic and formatting program written for the PDP-8 minicomputer family. This is a stand-alone program requiring only 8K of program memory. It allows the user to determine whether or not the floppy disk system is malfunctioning when a problem occurs, and if so, quickly and accurately determine which module is responsible for the malfunction.

VEP210 is an OS/8 compatible program, and can be called from the diagnostic disk using either the user's OS/8 monitor, or the DSD monitor included on the diagnostic disk. The DSD monitor can be loaded and run by the following procedure:

1. Place the diagnostic disk in drive 0 (left-hand drive).
2. Load the following bootstrap sequence through the front panel.

33/	6755
34/	5054
35/	5045
45/	7326
46/	6751
47/	4053
50/	3002
51/	2050
52/	5047
53/	6753
54/	6753
55/	5033
56/	6752
57/	5453
60/	7004

3. Start at location 33. If the diskette is write-protected, the computer will halt at location 7604. Pressing the CONTINUE (or run) switch on the front panel will then start the monitor. Additionally, if at any time the computer is halted and you wish to restart in the monitor, this can be done by placing the diagnostic diskette in drive 0 and restarting at location 7605.

The monitor can also be loaded with the quick floppy boot provided with the system on paper tape. This can be done with the following procedure:

1. Insert the diagnostic diskette in drive 0 (left-hand drive).

2. Load the information printed on the paper tape leader into the memory locations indicated, using the front panel.
3. Place the first punched character on the paper tape over the reader prongs and set the reader to RUN.
4. Start at location 27. The CONTINUE (or run) switch will have to be pressed three times before the bootstrap will run.

When the bootstrapping operation has been successfully completed, the computer will respond by typing a period (.), indicating that the DSD monitor is running. Once in the monitor, the diagnostic can be called by typing:

R VEP210 (CR)

After typing the carriage return (CR), the system will access the diagnostic disk and respond with:

```
DSD VEP210-V4E          /program name and version
DEV750                 /device to be tested.
DRIVES#'S:
```

This indicates that the diagnostic has been successfully loaded and is running. The diagnostic diskette should now be removed, a blank, formatted diskette should be placed in each drive, and the PDP-8 switch register should be set to 0000. This last step is very important, as these switches will affect the operation of the diagnostic. Use of these switches will be discussed at a later time.

When these steps have been completed, enter the drive numbers that you wish to test, in the following manner:

```
1-Drive system: Type 0 (CR)
2-Drive system: Type 01 (CR)
3-Drive system: Type 012 (CR)
```

If you wish to test only one drive in a system, enter only that drive number at this time. After typing the carriage return (CR), the diagnostic will respond with:

A, B, F, S, R, V, or D:

This is a list of some of the tests available in the diagnostic. These tests, the interrupt commands that will allow you to control their execution, and the effects of the switch register on the operation of the diagnostic will be explained in the following paragraphs.

A. - Acceptance Test.

The acceptance test is the basic tool used for fault diagnosis of the DSD 210 system. It uses the sequential, random, and buffer fill-empty tests in a variety of sequences to test the operation of the floppy system. A better understanding of this test sequence can be obtained by reading the sections on these tests, the interpretation of error messages and the error register codes. Once these are understood, almost any problem with the DSD 210 can be identified and isolated to a single module for repair.

B - Buffer Fill-Empty Test.

This test checks the sector buffer on the controller for proper operation by first filling the buffer 1000 times with incrementing data and then reading (emptying) the buffer 1000 times. This test is done in 12- and 8-bit modes, and the TRANSFER REQUEST FLAG (TRREQ.) is checked during each transfer.

F - Format Option.

This routine allows the user to rewrite the format onto an erased floppy disk. It is run in the following manner:

1. Type "F." the diagnostic will respond with:

FORMAT DRIVE:

2. Type the drive number you wish to reformat (0, 1, or 2) and a space. The system will respond with:

SEQUENTIAL FORMAT?

3. Type Y for a sequential format, N for an interleaved format. The sequential format is used with all DEC processors (PDP-8/E,F,M,&A), and the interleaved format is used with slower processors, such as the Intersil IM6100 microprocessor. A block diagram of the track format is included in the section entitled "Interpretation of DSD 210 Error Register Codes".

S - Sequential Read/Write Test.

This test sequentially writes data on all sectors from tracks 1 through 76 (it does not write on track 00) using the OS/8 block mapping, then sequentially reads all the blocks written and checks the data. The diagnostic will print "W" while writing and "R" while reading. This test will repeat continuously when called using the "S" command.

R - Random Read/Write Test.

The random test randomly chooses a drive number and OS/8 block number, then randomly reads or writes onto the disk. The diagnostic only prints error messages during this test, and will run continuously without exiting when called using the "R" command. This test is especially useful when attempting to spot and diagnose head positioning problems.

V - Verify.

This test is identical to the acceptance test (A), with one exception: the first pass is restricted to 77 0S/8 blocks, allowing the user to verify system operation more quickly than could be done using the normal acceptance test. After the first pass, the diagnostic prints out "PROCEEDING" and returns to the normal acceptance test. This test has been specially written for testing over extended periods of time.

D - Device Code Change.

The device code change option allows the user to test a system having a device code other than 75, and also to test up to four systems in sequence. This can be set up in the following manner:

Type D. The system will respond with: DEV750:

If at this time you wish to change the device code, the new code should be entered in the following manner:

1. Type the new device code (I.E. - 74, 71, etc.)
2. Type the number of drives in the floppy system (1, 2, 3)
3. Type a space. The system will respond with "DEV10:" an example of the results would be:

DEV 750: 742 DEV0:

This indicates that the diagnostic will now test device 74, which is a 2-drive system. Up to four systems can be tested in this manner.

If you wish to merely examine the device code register without changing the contents, type a space after the colon (:). When you wish to exit from the routine, or delete the contents of the register shown, type a carriage return.

Interrupt Restart Commands

The following commands are used to exit from various routines and tests, restart the program in various locations, and list and reset the cumulative status registers. A thorough understanding of these commands is necessary for efficient use of the diagnostic as a troubleshooting tool.

Control R - This command will interrupt whatever routine is currently being run and allow the user to select another routine (system prints "A,B,F,S,R,V, or D:"). This is equivalent to a restart at location 201 if the processor is halted.

Control D - This command interrupts the current routine, resets the status registers, and restarts the diagnostic. (System prints "VEP210-V4E, DEV750, DRIVE#'S:, allowing user to reset the drives to be tested). This is equivalent to a restart at location 200.

- Control C - Control C interrupts the current routine, and causes the system to attempt to restart in the DSD monitor. As this requires reading the monitor from the diagnostic diskette, the diagnostic should be interrupted using either Control R or Control D, and the diagnostic diskette should be placed in Drive 0 before using this command.
- Control T - Control T causes the cumulative status registers to be displayed. If the diagnostic is running a test routine, only the status for the drive selected when the command is given will be displayed, and the test will then continue. If, however, the diagnostic is waiting for a command, (at A,B,F,S,R,V, or D:), the status for all drives and systems set into the diagnostic will be displayed. Status readouts will display the following information:

Drive Number.
 Total Reads.
 Total Writes.
 Total Data Comparison Errors.
 Total Hardware Based Errors.
 Error Register Status and Number of Each
 Hardware Error Type.

Additionally, if the command is given during execution of a test routine, the display will include the current OS/8 block number, track, and sector of the selected drive. The following is an example of the status display:

```
DSK0 BLK=14T,S=116
TOT READ=10246 TOT WRITES=11437 DATA ERRS=0001
HDWERRS=0001 ST=100#1
```

This would indicate that drive 0 was interrupted at OS/8 block number 14, track 11, sector 6; the diagnostic had completed 10246 (octal) reads, 11437 writes, and had detected 1 data comparison error and 1 hardware based error, which was error register code 100, a write protect error. Again, the status register can be cleared by executing a control D.

Effects of Switch Register Settings on the Diagnostic Tests.

The PDP-8 switch register can be used to control the operation of the various diagnostic tests. The following will list some of the switch functions and explain briefly their effects on the operation of the diagnostic.

- Switch 0 - Suppresses the printout of data comparison errors. Only hardware-related errors will be printed.
- Switch 1 - Suppresses the use of the interrupt system. Also suppresses all interrupt-related errors.

- Switch 2 - Suppresses the printout of all hardware-related errors. When used with switch 0, this effectively suppressed all error messages.
- Switch 4 - Inhibits all other switches. Effectively, this switch disables all the others.
- Switch 5 - Prevents device cycling when more than one floppy system is being tested. When this switch is up, the diagnostic will only test the system currently selected.
- Switch 11- Prevents floppy disk system from writing on either drive. This is effectively a software write protect switch, and does not effect any read functions.

INTERPRETATION OF VEP210 ERROR MESSAGES.

Errors detected in VEP210 are all recorded in the status registers and reported in the following manner:

Type of error (Read, Write, or Data)
 Drive number that the error occurred on (DSK0, 1, or 2)
 OS/8 block number
 Track and sector
 Error register status

A good example of this would be:

WRITE ERR DSK1 BLK=232T,S=31 23 STATUS=100

This error message would indicate that a write error was detected on drive 1 at OS/8 block number 232, track 21, sector 23. The error register status was 100, or a write protect error. * (Error register codes will be covered more thoroughly in another section). Additionally, data comparison errors (reading the wrong data from the disk) will be reported in the following manner:

DATA ERR DSK0 BLK=25T,S=5 17 ADDR=3600 WROTE=25 READ 320

This would indicate that a data error was detected on drive 0, OS/8 block 25, track 5 sector 17. The system read 320 from buffer address 3600 and expected to find 25.

*See software section in Users Manual

```

; *****
; SBTTL ERRREG ERROR CODES
; *****

```

```

; ERROR CODES GIVEN BY READ ERROR-REG STATUS FUNCT (FUNCT 7)
; PRINTED AS ERRREG: XX ON ERROR PRINTOUT

```

```

; CODE LIGHT # MEANING
; 10 2 DRIVE 0 FAILED TO HOME ON INIT, OR DIDN'T SELECT
; 20 2 DRIVE 1 FAILED TO HOME ON INIT, OR DIDN'T SELECT
; 30 2 FOUND HOME WHEN STEPPING OUT 10 TRACKS FOR INIT.
; 40 2 TRACK GREATER THAN 77. OR UNIT SELECT ERROR.
; 50 2 HOME BEFORE DESIRED TRACK FOUND.
; 70 2 DESIRED SECTOR COULD NOT BE FOUND AFTER 2 REVS.
;
; 100 3 WRITE PROTECT ERROR. - SETS RXES <10>
; 110 MORE THAN 48 USEC AND NO SEPERATED CLOCK FOUND.
; 120 0 NO PREAMBLE WAS FOUND (24 BITS OF 0'S)
; 130 0 PREAMBLE FOUND BUT NO ID ADDR MARK WITHIN WINDOW
; 140 CRC ERROR ON WHAT APPEARED TO BE HEADER.
; DOESEN'T SET ERROR FLAG WHEN ENCOUNTERED.
; 150 2 HEADER TRACK ADDRESS OF A GOOD HEADER DIDN'T
; MATCH DESIRED TRACK.
; 160 0 TOO MANY TRIES FOR AN I. D. ADDRESS MARK.
; 170 0 DATA ADDRESS MARK NOT FOUND IN ALLOTTED TIME.
; 200 0 CRC ERROR ON READING SECTOR FROM DISK.
; RXES STATUS BIT OF VALUE 1 IS ALSO SET.
; 210 1 PARITY ERROR (INTERFACE <=> CONTROLLER)
; RXES STATUS BIT OF VALUE 2 IS ALSO SET.
; 220 2 DRIVE 2 FAILED TO HOME ON INIT.
; 230 2 DRIVE 3 FAILED TO HOME ON INIT.
; 240 SELECTED DRIVE NOT READY (110 ONLY)
; INDEX HOLE NOT ON TIME
; 250 0 EXPECTED HEADER NOT FOUND AFTER TRACK FORMAT.
; 260 0 INDEX MARK NOT FOUND IN EXPECTED RANGE.
; (FORMAT NOT BEGUN)
; 270 0 INDEX MARK NOT FOUND IN EXPECTED RANGE.
; (FORMAT HAS OCCURED)
; 300 DATA LOST FROM WESTERN DIGITAL 1771 TO 8048.
; (110 CONTROLLER ONLY)

```

```

; SOFTWARE CONDITIONS REPORTED AS STATUS ERRORS
; 177 TIMEOUT ON DONE
; 176 TIMEOUT ON TRREG
; 1 INTERRUPT ERROR

```

```

; FRONT PANEL ERROR LIGHT DESCRIPTION
; LIGHTS MEANING
; 0 FRONT DATA TYPE ERROR
; 1 FRONT PARITY ERROR BETWEEN CONTROLLER-INTERFACE.
; 2 FRONT SEEK TYPE ERRORS
; 3 FRONT SWITCH CONFLICT ERROR OR CONTROLLER ERROR.
; INCLUDES WRITE PROTECT OR FORMAT INHIBITED
; ERROR TYPES.
; BOARD LIGHTS (210 ONLY)
; UP-LEFT CONTROLLER WAITING FOR BUS INTERFACE READY.
; UP-RIGHT INIT IN PROGRESS.
; LW-LEFT READ IN PROGRESS
; LW-RIGHT WRITE IN PROGRESS.

```

VEP 210/SA120
Alignment Program

The SA120 Program is designed to operate in conjunction with Shugart Associates' SA120 Drive Head Alignment Diskette. It should be pointed out that head misalignment is a rare malady indeed, with Shugart drives. For this reason alignment should only be attempted by qualified individuals familiar with Shugart's alignment procedures as outlined in the Drive Manual and the operation of an oscilloscope.

Running the Program: Place VEP 210 Diagnostic Diskette in Unit 0. Boot the Diskette normally (using boot switch or one of the bootstrap programs listed in the DSD Documentation). The console device will respond with a monitor prompt.

Switch Bank: (if available) = 0
Type: R SA120 (CR)

Floppy will respond by stepping out to SA120 Alignment Track 43 (octal) and loading the head.

Remove Diagnostic Diskette and insert the SA120 Alignment Diskette. Refer to Shugart Drive Manual provided with DSD Documentation.

Other Tracks: If a front panel or switch bank is available the drive head will position itself at the track equal to the value loaded into the switch register.

Range = 1 - 76 (decimal), 1 - 114 (octal)*
Example: Switch Register = 0 0 17 (octal)

Head will move to Track 15 (decimal)

*Head will not go to Track 0 since 0 is the default value for Track 43 (octal). Values greater than 114 (octal) will cause seek errors.

Testing Other Units: Other units may be tested using the device select switches on the main controller board to assign other units to respond as Unit 0. The normal condition of the switches should be recorded before any changing is done.

Getting Back to Monitor: Halt the processor, insert Diagnostic Diskette in Unit 0, restart processor at address 7605 (octal).

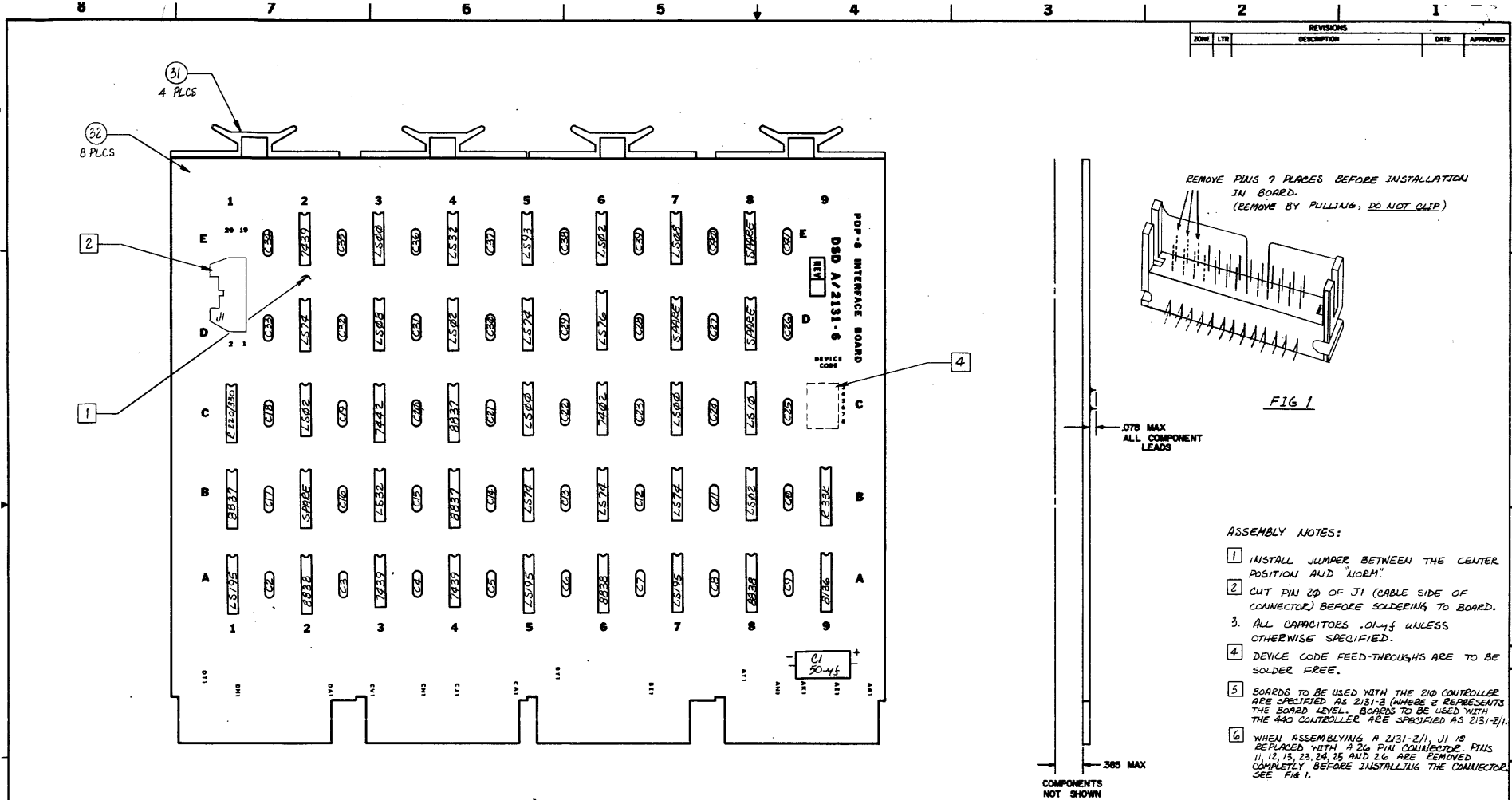

VIEW COMPONENT SIDE

REVISIONS				
ZONE	LYR	DESCRIPTION	DATE	APPROVED

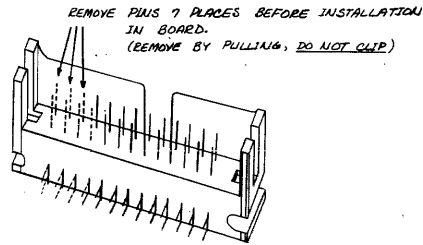

FIG 1

ASSEMBLY NOTES:

- 1 INSTALL JUMPER BETWEEN THE CENTER POSITION AND "NORM."
- 2 CUT PIN 26 OF J1 (CABLE SIDE OF CONNECTOR) BEFORE SOLDERING TO BOARD.
- 3 ALL CAPACITORS .01-μf UNLESS OTHERWISE SPECIFIED.
- 4 DEVICE CODE FEED-THROUGHS ARE TO BE SOLDER FREE.
- 5 BOARDS TO BE USED WITH THE 210 CONTROLLER ARE SPECIFIED AS 2131-2 (WHERE 2 REPRESENTS THE BOARD LEVEL. BOARDS TO BE USED WITH THE 440 CONTROLLER ARE SPECIFIED AS 2131-2/1).
- 6 WHEN ASSEMBLING A 2131-2/1, J1 IS REPLACED WITH A 26 PIN CONNECTOR. PINS 11, 12, 13, 23, 24, 25 AND 26 ARE REMOVED COMPLETELY BEFORE INSTALLING THE CONNECTOR. SEE FIG 1.

COMPONENTS NOT SHOWN

(UNLESS OTHERWISE SPECIFIED DIMENSIONS ARE IN INCHES. TOLERANCES ARE: FRACTIONS DECIMALS ANGLES ± 1/64 ± 0.02 ± 1° ± 0.005	CONTRACT NO.	Digital Systems PDP-8 BUS INTERFACE 210 FLOPPY CONTROLLER ASSEMBLY DRAWING
	APPROVALS DRAWN J. MOISE 7/28/78 CHECKED S. ZUSCHER 8/3/78	
SEE LIST OF MATERIALS	MATERIAL	SIZE D CODE IDENT NO. DRAWING NO. ASI 2131-0A/1X REV
FRESH	DO NOT SCALE DRAWING	SCALE 1.5:1 AS-1 SHEET 1 OF 1

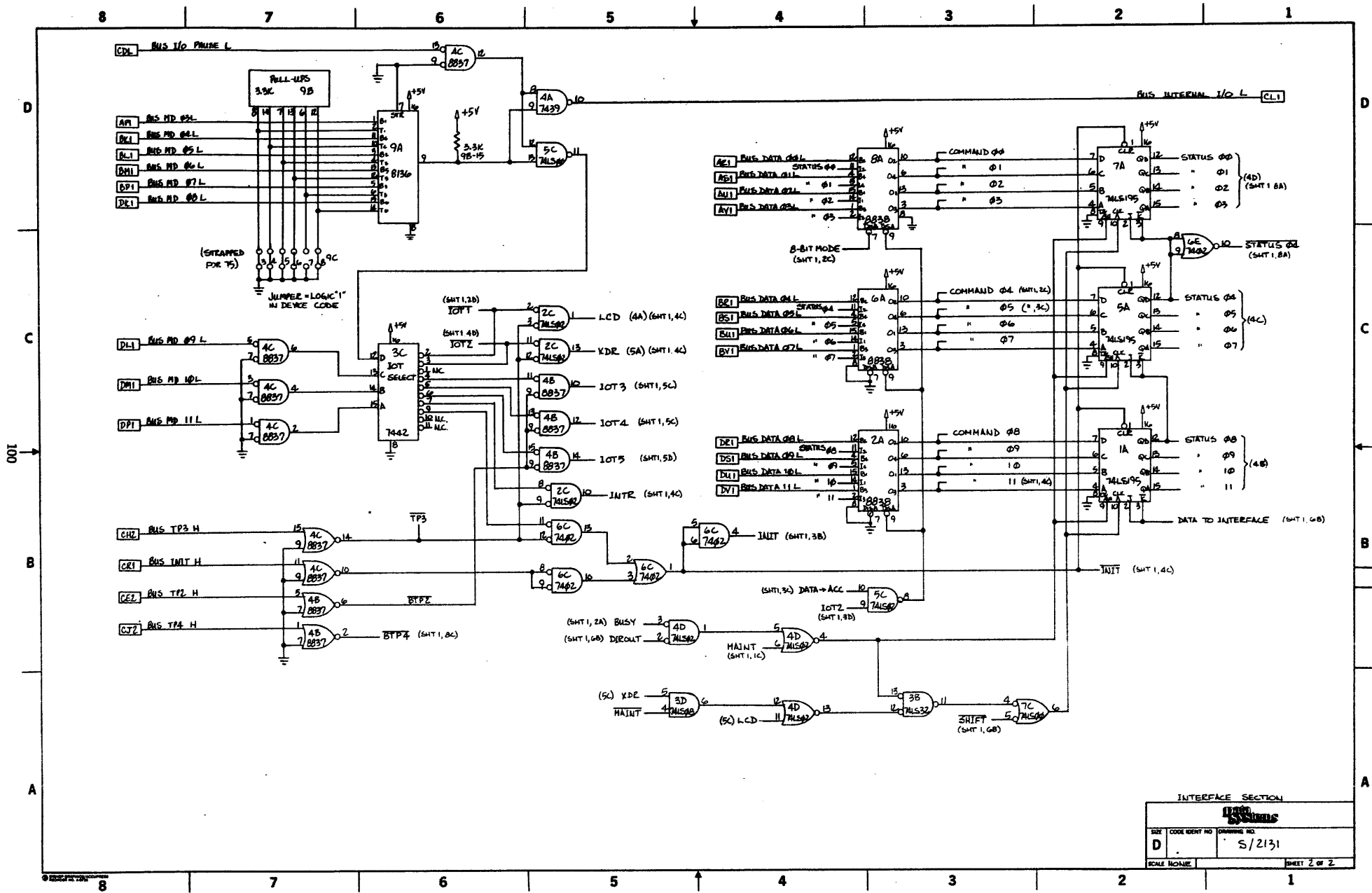

INTERFACE SECTION		
REV	CODE IDENT NO	DRAWING NO
D		S/2131
SCALE	NO/NAME	SHEET 2 OF 2

OVERVOLTAGE PROTECTION

SPECIFICATIONS:

VOLTAGE ADJUSTMENT RANGE: 6.5 – 33.0 VDC

MAXIMUM CURRENT: 12 AMPS Intermittent
 8 AMPS Continuous

ADJUSTMENT PROCEDURE:

The OVP unit should be adjusted to trigger at the suggested voltage as indicated in Figure 1.

POWER SUPPLY OUTPUT VOLTAGE	SUGGESTED OVP TRIGGER VOLTAGE	R1	M1
5 VDC	6.5 VDC	68 Ω 1 w	ACCURATE TO WITHIN 1% OF SUGGESTED OVP TRIGGER VOLTAGE
6	7.8	82 Ω 1 w	
12	14	150 Ω 2 w	
15	17	200 Ω 2 w	
18	21	250 Ω 5 w	
20	24	250 Ω 5 w	
24	28	300 Ω 5 w	

FIGURE 1

1. Connect test circuit as shown in Figure 2.
2. Energize and adjust the test voltage source to the suggested OVP trigger voltage.
3. Slowly rotate the adjustment potentiometer (R5) from its

maximum clockwise position until the OVP unit triggers as indicated by a zero reading on M1. Leave R5 in this position.

4. The unit is now properly adjusted and ready for installation.

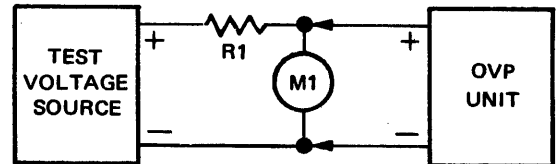

ADJUSTMENT TEST CIRCUIT
 FIGURE 2

INSTALLATION PROCEDURE:

Connect the OVP unit in parallel with the power supply as indicated in Figure 3.

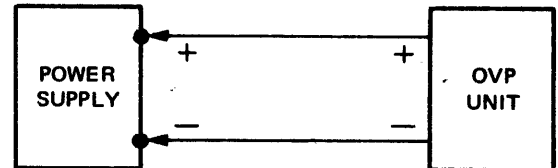

OVP INSTALLATION DIAGRAM
 FIGURE 3

TROUBLESHOOTING GUIDE

FAILURE INDICATION	CHECK
1. UNIT REMAINS SHORTED AFTER AN OVERVOLTAGE CONDITION IS CORRECTED.	SCR1 SHORTED Q1 SHORTED CR2 SHORTED
2. UNIT REMAINS SHORTED AFTER ALL VOLTAGE IS REMOVED.	SCR1 SHORTED
3. UNIT TRIGGERS ERRATICALLY ON NOISE SPIKES OR TRANSIENTS.	C1 OPEN
4. UNIT FAILS TO TRIGGER.	SCR1 OPEN Q1 OPEN CR2 OPEN R5 OPEN C1 SHORTED

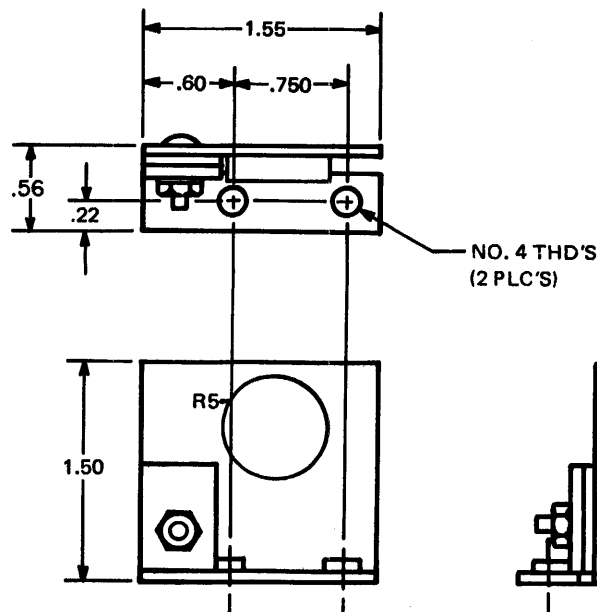

The information and designs contained herein are the exclusive property of POWERTEC INC. and use thereof without the express and written consent of POWERTEC INC. is prohibited.

REVISIONS			
SYM	DESCRIPTION	DATE	APPROVED
A	ECO # 014997	1-31-79	A.L.

SYM	POWERTEC P/N	COM'L EQUIV	DESC
C1	32-13006-001	PCZ1PA50	1MFD, 50V
CR1	13-13015-001	2N4441	---
CR2	12-13025-007	1N752A	---
R1	20-13004-051	RC206F12J	120Ω, 1/2W, 5%
R2	20-13004-073	RC206F102J	1K, 1/2W, 5%
R3	20-13004-065	RC206F47J	470Ω, 1/2, 5%
R4	20-13004-060	RC206F30J	300Ω, 1/2W, 5%
R5	23-13016-002	CTS-III	1.5K
Q1	10-13020-001	2N2907A	---
BRACKET	50-12836	---	---
P.C.B.	55-12789	---	---

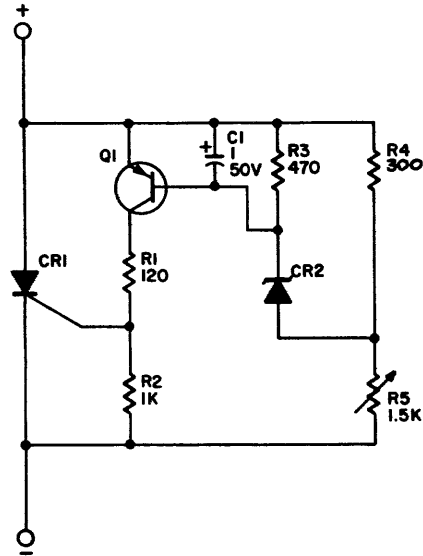

COPY

13207

A

102

QTY REQD	PART NO. OR TYPE DESIGNATION	SYM	NOMENCLATURE OR DESCRIPTION	CODE IDENT	MATERIAL, NOTES AND SPECIFICATIONS	ITEM NO.
LIST OF MATERIALS						
UNLESS OTHERWISE SPECIFIED: DIMENSIONS ARE IN INCHES TOLERANCES ON DECIMALS X ± .10 XX ± .030 ANGLES X-X ± 0.30 XXX ± .010			CONTRACT NO.		POWERTEC DIVISION AIRTRONICS INCORPORATED 9168 DESOTO AVE., CHATSWORTH, CALIF. 91311	
MATERIAL			APPD <i>SPK</i> 10/29/70	TITLE OEM OVP ADJ. 6.5 TO 30VDC 12 AMPS MAX.		
FINISH			CHECK <i>D. WEISSE</i> 10/29/70	SIZE C	CODE IDENT NO. 24429	DRAWING NUMBER 13207
DO NOT SCALE DRAWING REPORT ERRORS TO ENGINEERING DEPT DO NOT MAKE CHANGES WITHOUT PROPER AUTHORIZATION			DRAWN <i>M. PIERCE</i> 10-26-70	APPROVED <i>[Signature]</i> 10/29/70	REV. A	SHEET 1 OF 1

NOTE: UNLESS OTHERWISE SPECIFIED

POWERTEC

9168 DESOTO AVENUE
 CHATSWORTH CALIFORNIA 91311
 TWX 910-494-2092
 (213) 882-0004

APPLICATION DATA OEM II SERIES—MULTIPLE OUTPUT REGULATED D. C. POWER SUPPLY

MODELS 2L SERIES

SPECIFICATIONS :

A.C. INPUT: 105-125VAC/210-250VAC, 47-63Hz
 Derate 10% below 57Hz.

D. C. OUTPUT RATINGS								
MODEL	OUTPUT			CONNECTIONS		REGULATIONS		
	PCB	VOLT	MAX AMPS	TRANSFORMER		LINE(1)	LOAD(2)	
				INPUT*	OUTPUT			
2L15D-2.8B	A1	12	3.0	1-2	3-5	6mV	6mV	
		15	2.8		3-6	7.5mV	7.5mV	
	A2	12	3.0		3A-5A	6mV	6mV	
		15	2.8		3A-6A	7.5mV	7.5mV	
	2L5D-6.0B	A1	5		6.0	---	5mV	7.5mV
			6		5.0	---	6mV	9mV
A2		5	6.0	---	5mV	7.5mV		
		6	5.0	---	6mV	9mV		
2L5,15DB	A1	5	6.0	---	5mV	7.5mV		
		6	5.0	---	6mV	9mV		
	A2	12	3.0	3A-5A	6mV	6mV		
		15	2.8	3A-6A	7.5mV	7.5mV		
2L5,24DB	A1	5	6.0	---	5mV	7.5mV		
		6	5.0	---	6mV	9mV		
	A2	18	2.0	3A-5A	9mV	9mV		
		20	2.3	3A-5A	10mV	10mV		
		24	2.3	3A-6A	12mV	12mV		

Optional input models require transformer input connections in accordance with the information listed in the table below (output connections remain the same as those listed under 'D.C. OUTPUT RATINGS').

OPTIONAL INPUT INFORMATION					
MODEL SUFFIX	INPUT Vac		CONNECTIONS		INPUT FUSE
	NOM	LO-HI	INPUT	JUMP	
-01	100	91-109	1&2	1-8,2-9	2.0A
	200	182-218	1&9	2-8	1.0A
-02	115	105-125	1&2	1-8,2-9	2.0A
	230	210-250	1&9	2-8	1.0A
-03	208	190-226	1&2	---	1.0A
	220	201-239	1&8	---	1.0A

OUTPUT RIPPLE: 5 mV P-P max. all voltages, any combination of line and load.

TRANSIENT RESPONSE: 30 μ S typical for a 50-100% load transition.

STABILITY: $\pm 0.1\%$ for 8 hours after warm-up.

TEMPERATURE COEFFICIENT: $\pm 0.02\%/^{\circ}\text{C}$ max. $\pm 0.005\%/^{\circ}\text{C}$ typical.

OVERLOAD PROTECTION: Units are protected from overload and short circuit by current foldback or current limit (see 'Adjustment Procedure--Overload Protection' for clarification).

THERMAL DERATING: 100% load at 0 $^{\circ}$ C-40 $^{\circ}$ C ambient. Derate as follows above 40 $^{\circ}$ C.

40 $^{\circ}$ C	55 $^{\circ}$ C	71 $^{\circ}$ C
100%	75%	50%

INPUT FUSING: 2.0A input fusing is recommended for standard 115 Vac input power supply (see 'Optional Input Information' for fusing of optional input models). Fusing is mandatory when crowbar over-voltage protection is utilized.

WEIGHT: 8 lb

* See 'OPTIONAL INPUT INFORMATION' for connection information regarding models with suffix of -01, -02 or -03.

- 1) For a low-line to high-line voltage transition.
- 2) For a 0-100% load transition.

ADJUSTMENT PROCEDURE :

OUTPUT VOLTAGES:

Output voltages are adjusted using the 'Vadj' adjustment (increase - cw).

OVERLOAD PROTECTION:

The overcurrent protection is factory adjusted to provide rated output current and proper supply protection at all rated outputs. Current foldback is utilized in all cases except where two outputs on one model are the same (ie, dual 5V or dual 15V outputs), in which case current limit is used. Readjustment is possible only on outputs of 25W or over, and is accomplished by turning 'I_{lim}' full cw, setting the output voltage to that desired and applying a load equal to 125% of the new full load rating. Adjust 'I_{lim}' ccw until the output voltage decreases 50-100 mV. This should be accomplished with the supply near room temperature.

VOLTAGE SENSING:

LOCAL: For most applications local voltage sensing provides adequate regulation at the load. These supplies operate in local sense automatically and require no sense jumpers.

REMOTE: Remote sensing is standard on all outputs of over 10W, and should be utilized where load lead losses become excessive.

CAUTION---To minimize the possibility of system instability keep load leads short, conservatively sized, and twisted together. Also twist sense leads and do not route near any A. C. leads. The hook-up for remote sensing is as follows:

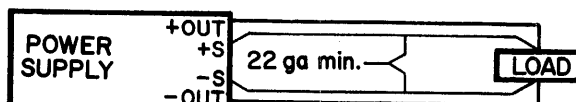

NOTE: These supplies are designed to prevent excessive voltage excursions in the event of an open sense lead.

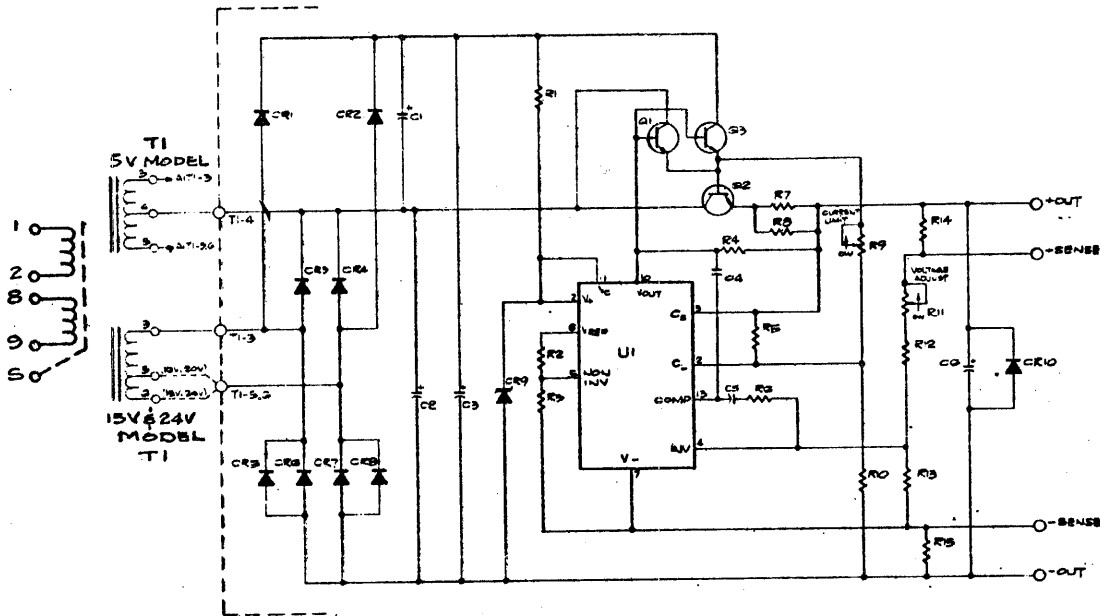

REF. DES.	2C5	2C10	2C15	2C2A
C1	1000/16V			
△ C2	16K/15V	7300/35V	7300/35V	5000/50V
C3		47/50V	47/50V	47/50V
C4				
C5	.0022/1KV	.001/1KV	.001/1KV	470 PFD/1KV
C6	470/16V	220/35V	220/35V	220/35V
CR1,2	1A	1A	1A	1A
CR3,4		3A	3A	3A
CR5,6	3A			
CR6,7	3A	3A	3A	3A
CR9				1N4754A
CR10	1A	1A	1A	1A
Q1		010-13018-002	010-13018-002	010-13018-002
Q2	010-19655-001	010-19655-001	010-19655-001	010-19655-002
Q3	010-19655-001			
R1	270Ω 1/2W 5%	47Ω 1/2W 5%	47Ω 1/2W 5%	330Ω 1/2W 5%
R2	4.3K MF 1/2W 2%	510Ω 1/2W 5%	680Ω 1/2W 5%	680Ω 1/2W 5%
R3	5.1K MF 1/2W 2%			
R4	1K 1/2W 5%	3.3K 1/2W 5%	3.3K 1/2W 5%	2.7K 1/2W 5%
R6	7.5Ω 1/2W 5%	7.5Ω 1/2W 5%	7.5Ω 1/2W 5%	7.5Ω 1/2W 5%
R7	.15W	.22 W	.1 W	.15 W
R8	.15W	.22 W		
△ R9	100Ω W/W POT	100Ω W/W POT	100Ω W/W POT	100Ω W/W POT
△ R10	330Ω 1/2W 5%	680Ω 1/2W 5%	1.0K 1/2W 5%	2.7K 1/2W 5%
△ R11	1.5K W/W POT	1.5K W/W POT	1.5K W/W POT	1.5K W/W POT
R12	150Ω MF 1/2W 2%	JUMP	750Ω MF 1/2W 2%	1.2K 1/2W 2%
R13	1.8K MF 1/2W 2%	2K 1/2W 2%	1.5K MF 1/2W 2%	910Ω 1/2W 2%
R14,15	7.5Ω 1/2W 5%	7.5Ω 1/2W 5%	7.5Ω 1/2W 5%	7.5Ω 1/2W 5%
U1	μA723	μA723	μA723	μA723
T1	040-20612-003	040-20612-014	040-20612-007	040-20612-011

△ 032-13007-019,-020,-021 RESPECTIVELY

△ 023-13016-004

△ 023-13016-002

△ CAPACITANCE IS IN MICROFARADS

REFERENCE ONLY

REVISIONS			
LTR	DESCRIPTION	DATE	APPROVED
B	ECO 014880	2/25/5	
C	ECO 01555/01556	12/10/75	Mib
D	ECO 01555/01556	2/1/76	Mib
E	ECO 016093	3/22/76	Mib
F	ECO 016093	4/1/76	Mib
H	ECO 016106	4/16/76	Mib

POWERTEC INC. A SUBSIDIARY OF AIRTRONICS 9168 DESOTO AVE., CHATSWORTH, CALIF., 91311			
TITLE			
SCHEMATIC			
OEM II, 2C			
SIZE	CODE IDENT. NO.	DWG. NO.	REV.
A	24429	20155	H
SCALE	SHEET 1 OF 1		

CP118 ELECTRICAL SPECIFICATIONS

AC INPUT: 100/120/220/240/VAC $\pm 10\%$ 47-63Hz

OUTPUT: 5VDC AT 9.0A OVP AT $6.4 \pm .4$ VDC

24VDC AT 2.4A

LINE REGULATION: $\pm .05\%$ FOR A 10% LINE CHANGE

LOAD REGULATION: $\pm .05\%$ FOR A 50% LOAD CHANGE

OUTPUT RIPPLE: 3MV PK-PK MAX

TRANSIENT RESPONSE: 30 μ FOR A 50% LOAD CHANGE

OVERLOAD AND SHORT CIRCUIT PROTECTION: AUTO-
MATIC CURRENT LIMIT/FOLDBACK

STABILITY: $\pm .3\%$ FOR 24 HRS AFTER WARM-UP

TEMPERATURE COEFFICIENT: $\pm .03\%/^{\circ}\text{C}$ MAX

COOLING: UNITS ARE FULL RATED TO 50 $^{\circ}\text{C}$ IN FREE
AIR, MUST BE FAN COOLED WHEN MOUNTED IN CONFINED
AREA

TEMPERATURE RATING: 0-50 $^{\circ}\text{C}$ -100%

60 $^{\circ}\text{C}$ - 60%

70 $^{\circ}\text{C}$ - 40%

CONSTRUCTION: ALL ALUMINUM CHASSIS

WEIGHT:

MICROCOMPUTER POWER, INC.
 MANUFACTURERS OF D.C. POWER SUPPLIES
 3080 LAWRENCE EXPWY.
 SANTA CLARA, CA 95051
 (408) 736-5303

CP118 Power Supply
 Parts List

Ref. Des.	CP118(+5VDC Card)	Description
C1	50,000/15	Capacitor Alum Elect
C2,C3	1000/16	" " "
C4	.001/100	Capacitor Mylar
CR1	R711A	Rectifier TO-3 30A 100V
CR2,3	AE1C	" 1A 200V
CR4	1N752A	Diode Zener 300mW
R1,2,4,5	6.8	Resistor 1/2W 5% CF
R3	47	" " "
R6,7	3.9	(1-10 2-22 in parallel) " " "
R8	2.2K	" " "
R11	1.5K	" " "
R9,10	1500	Potentiometer 2W WW
SCR1	S0308LS3	SCR 8A 30V
U1	uA723C	I.C. Voltage Regulator
PCB	10077	Printed Circuit Board
Q1,2,3	2N3055	Transistor Power NPN

MICROCOMPUTER POWER, INC.
MANUFACTURERS OF D.C. POWER SUPPLIES
3080 LAWRENCE EXPWY.
SANTA CLARA, CA 95051
(408) 736-5303

CP118 Power Supply
Parts List Cont.

Ref. Des.	CP118(+24VDC Card)	Description
C1	5000/50	Capacitor Alum Elect
C2	330/35	" " "
C3	47/50	" " "
C4	.001/100	Capacitor Mylar
CR1,2	AE3B	Rectifier 3A 100V
CR3	AE1C	" 1A 200V
CR5	1N752A	Diode Zener 300mW
R4	1.1K	Resistor 1/2W 5% CF
R5	750	" " "
R6,8,9	10K	" " "
R7	270	" " "
R11	1500	Potentiometer 2W WW
R3	.12	Resistor 2W WW 5%
U1	uA723C	I.C. Voltage Regulator
Q1	2N2219A	Transistor Small Signal NPN
Q2	2N3055	Transistor Power NPN
PCB	10006	Printed Circuit Board

MICROCOMPUTER POWER, INC.
MANUFACTURERS OF D.C. POWER SUPPLIES
3080 LAWRENCE EXPWY.
SANTA CLARA, CA 95051
(408) 736-5303

AC CONNECTION TABLE			
VAC	JUMPER	APPLY VAC	FUSE AT
100	1&3, 2&5	1&4	3.0A
120	1&3, 2&5	1&5	3.0A
220	2&3	1&4	1.5A
240	2&3	1&5	1.5A

MICROCOMPUTER POWER, INC.
MANUFACTURERS OF D.C. POWER SUPPLIES
3080 LAWRENCE EXPWY.
SANTA CLARA, CA 95051
(408) 736-5303

CP118 Power Supply Trouble Shooting Guide

SYMPTOM	POSSIBLE PROBLEM
Unit Overheating	1. Output overload 2. AC input too high 3. Inadequate ventilation 4. Improper transformer primary connection
Low Output Voltage with High Ripple	1. Output overloaded 2. U1 faulty (U1 Faulty)* 3. CR1, 2, or 3 open (CR1, 2, or 3 open)* 4. C1 or C3 leaky or open (C1 or C2 leaky or open)* 5. Q1 or Q2 open (Q1, 2 or 3 open)* 6. R5 open (R1 open)* 7. SCR1 shorted or OVP triggered, +5 card only
High Output Voltage and Ripple, Poor Regulation	1. Q1 or Q2 shorted (Q1, 2, or 3 shorted)* 2. U1 faulty (U1 faulty)* 3. R11 open (R2 open)*
High Input Current Blows Fuses	1. Improper input voltage or frequency 2. C1 or C3 shorted (C1 or C2 shorted)* 3. CR1, 2 or 3 shorted (CR1, 2 or 3 shorted)*

*Components on +5 P.C. Card

**SHUGART DRIVE JUMPER CONFIGURATION FOR DSD 210
AS SHIPPED FROM SHUGART**

TRACE DESIGNATOR	DESCRIPTION	SHIPPED FROM SHUGART	
		OPEN	SHORT
T3,T4,T5,T6	Terminations for Multiplexed Inputs		Plugged
T1	Terminator for Drive Select		Plugged
T2	Spare Terminator for Radial Head Load	X	
DS1,DS2,DS3,DS4	Drive Select Input Pins	X	DS1 is Plugged
RR	Radial Ready		X
RI	Radial Index and Sector		X
R,I,S,	Ready, Index, Sector Alternate Output Pads		X
HL	Stepper Power From Head Load		Plugged
DS	Stepper Power From Drive Select	X	
WP	Inhibit Write When Write Protected		X
NP	Allow Write When Write Protected	X	
8,16,32,	8, 16, 32 Sectors (SA801 Only)	8 & 16	32
D	Alternate Input-In Use	X	
2,4,6,8,10,12,14,16,18	Nine Alternate I/O Pins	X	
D1,D2,D4,DDS	Customer Installable Decode Drive Select Option	X	
A,B,X	Radial Head Load		Plugged
C	Alternate Input-Head Load	X	
Z	In Use from Drive Select		Plugged
Y	In Use from HD LD	X	
DC	Alternate Output-Disk Change	X	

AS SHIPPED IN DSD 210

TRACE DESIGNATOR	DESCRIPTION	SHIPPED FROM DSD	
		OPEN	SHORT
T3,T4,T5,T6	Terminations for Multiplexed Inputs		Note 1
T1	Terminator for Drive Select		X
T2	Spare Terminator for Radial Head Load		X
DS1,DS2,DS3,DS4	Drive Select Input Pins	X	Note 2
RR	Radial Ready		X
RI	Radial Index and Sector		X
R,I,S,	Ready, Index, Sector Alternate Output Pads		X
HL	Stepper Power From Head Load	X	
DS	Stepper Power From Drive Select		X
WP	Inhibit Write When Write Protected		X
NP	Allow Write When Write Protected	X	
8,16,32,	8, 16, 32 Sectors (SA801 Only)	8 & 16	32
D	Alternate Input-In Use	X	
2,4,6,8,10,12,14,16,18	Nine Alternate I/O Pins	X	
D1,D2,D4,DDS	Customer Installable Decode Drive Select Option	X	
A,B,X	Radial Head Load	B	"X" A
C	Alternate Input-Head Load		Note 3
Z	In Use from Drive Select	X	
Y	In Use from HD LD		X
DC	Alternate Output-Disk Change	X	

NOTE 1: Last drive on daisy chain should have jumpers T3, T4, T5 and T6 installed.

NOTE 2: One jumper installed according to physical drive number.

NOTE 3: Connect Pin "C" to Pin 18, 16, 14 or 12 for physical drive number 0, 1, 2 or 3 respectively.

NOTE 4: Jumper L is open and the 800 option is shorted.

KEY: X – Specified signal is either open or shorted, depending upon in which column the "X" appears.

Plugged – Specified signal has a pair of wire wrap pins which are shorted together.

79

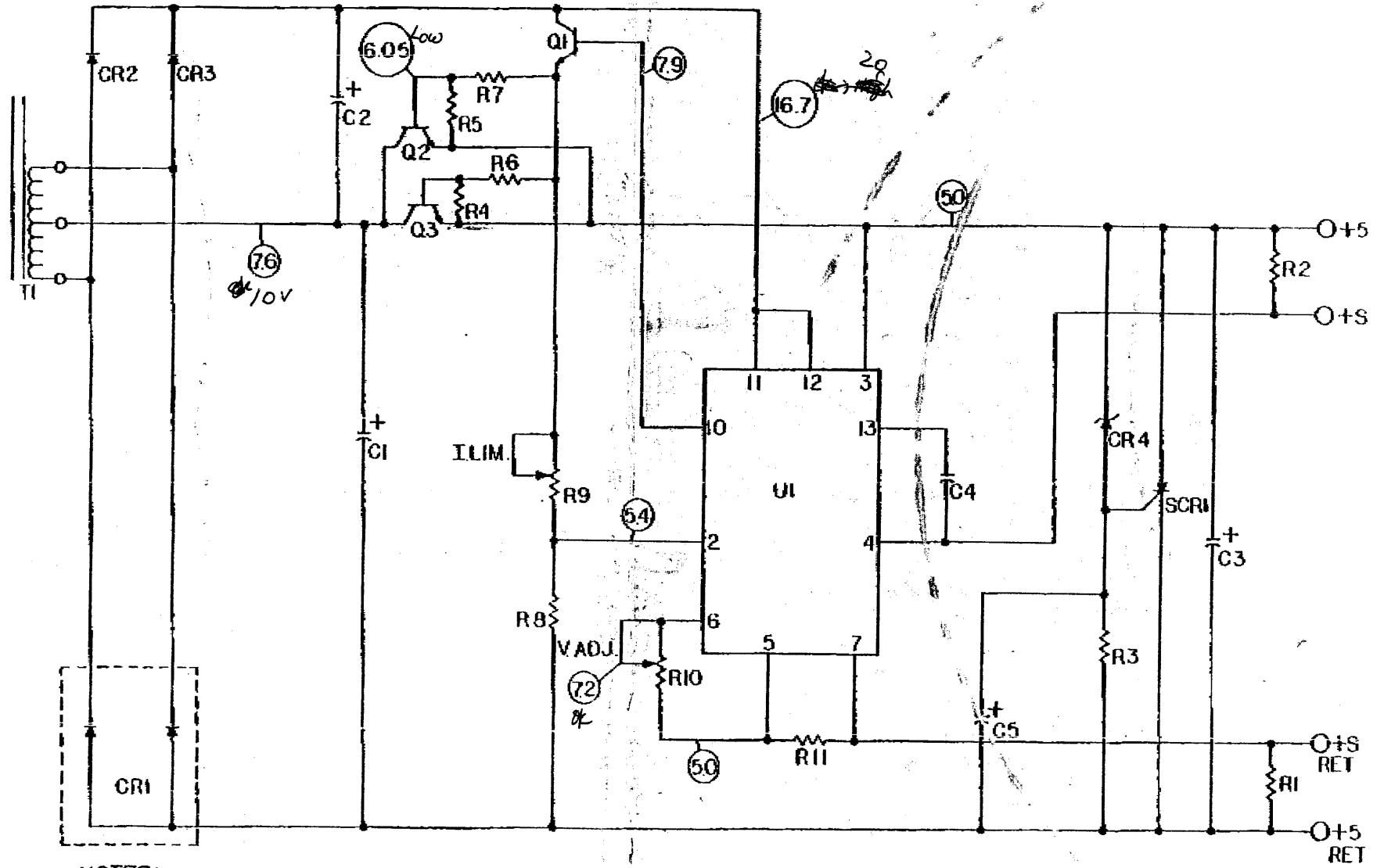

NOTES:

1. VOLTAGE MEASUREMENTS AT 115 VAC INPUT FULL LOAD ON OUTPUT.
2. ALL VOLTAGES REFERENCED TO +5 RET OUTPUT.
3. (50) DENOTES 5V UNIT.

79