

FIRST USED ON OPT/MOD.	QTY	DESCRIPTION	PART NO.	ITEM NO.
UNLESS OTHERWISE SPECIFIED				
DRAWN		DATE		
CHECKED		DATE		
APPROVED		DATE		
DESIGNED		DATE		
TESTED		DATE		
REVISIONS		DATE		
MATERIAL				
FINISH				

CORPORATION	
EQUIPMENT	
SYNCHRONOUS	
MODEM INTERFACE	
SCALE	SHEET 2 OF 2
DIST	





This drawing and specifications, herein, are the property of Digital Equipment Corporation and shall not be reproduced or copied or used in whole or in part as the basis for the manufacture or sale of items without written permission.

U-C-MICRO 2  
1320 838707 3000 3215

FUNCTION	WIRE	CONNECTION	
		FROM	TO
CLEAR TO SEND (CS)	C COND	PI-C	J1-T
SEND REQUEST (SR)	D COND	PI-D	J1-V
SEND DATA (SD)	E COND	PI-E	J1-F
DATA SET READY (DSR)	F COND	PI-F	J1-Z
RING INDICATOR (RI)	F SHIELD	PI-F	J1-X
LOCAL TEST (LT)	G COND	PI-G	J1-FF
SERIAL CLOCK TRANSMIT (SCT)	H COND	PI-H	J1-L
SERIAL CLOCK TRANSMIT (SCT)	J COND	PI-J	J1-N
RECEIVE DATA (RD)	K COND	PI-K	J1-U
SERIAL CLOCK RECEIVE (SCR)	L COND	PI-L	J1-R
AGC LOCK (AGC)	M COND	PI-M	J1-BB
DATA TERMINAL READY (DTR)	M SHIELD	PI-M	J1-DD
	C SHIELD	PI-C	J1-A
	D SHIELD	PI-D	J1-A
	E SHIELD	PI-E	J1-B
	G SHIELD	PI-G	J1-B
	H SHIELD	PI-H	J1-VV
	J SHIELD	PI-J	J1-VV
	K SHIELD	PI-K	J1-UU
	L SHIELD	PI-L	J1-UU
	A	PI-A	NC
	B	PI-B	NC

WIRE REFERENCE TABLE	
A	LOCATION OF WIRES IN WOVEN CABLE
B	
C	
D	
E	
F	
G	
H	
J	
K	
L	
M	

- NOTES:
- A TWISTED PAIR WIRE 6 IN. LONG WILL BE ATTACHED TO EACH CONDUCTOR OF EACH WIRE (1 WIRE TO INNER CONDUCTOR, 1 WIRE TO THE SHIELD). THE WIRES WILL THEN BE CRIMPED TO THE BERG PINS AS INDICATED.
  - WHEN SUPPLIED BY A VENDOR, THIS CABLE WILL BE FULLY TESTED BY VENDOR TESTED AND INSPECTED BY INCOMING INSPECTION PRIOR TO ACCEPTANCE.
  - THIS IS THE CABLE DESCRIBED BY PURCHASE SPECIFICATION 17-00019.
  - A COLORED TRACER WILL BE WOVEN INTO THE CABLE BETWEEN WIRES 'A' AND 'G'.
  - RG195 A/U CAN BE USED TO DIRECTLY REPLACE RG 180U.
  - NO SUBSTITUTIONS, OTHER THAN THOSE SPECIFIED IN THIS PRINT, MAY BE MADE WITHOUT PRIOR APPROVAL.

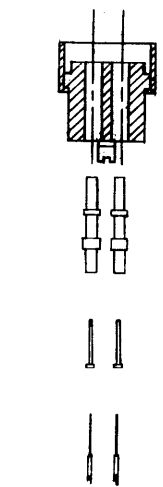
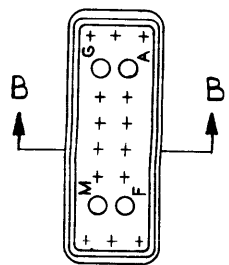
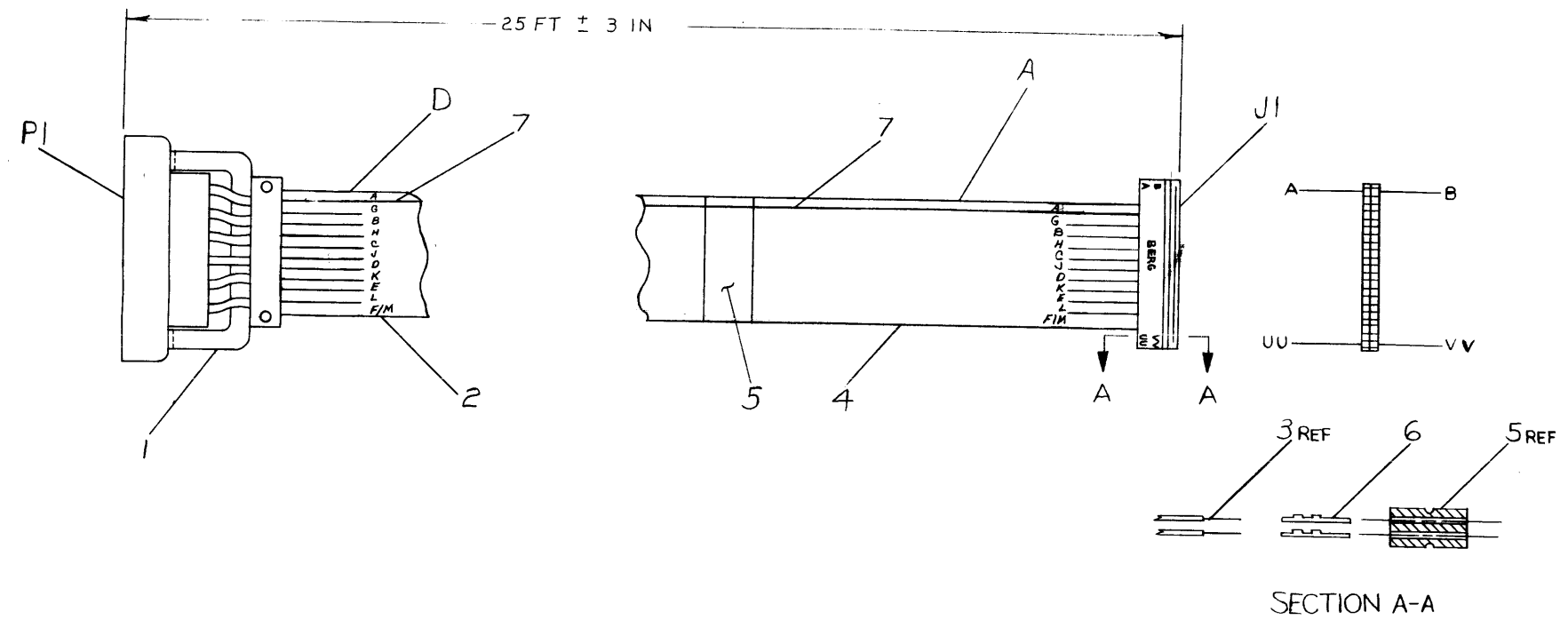

SECTION B-B

SECTION A-A

QTY.	DESCRIPTION	PART NO.	ITEM NO.
7	A/R COLORED TRACER		7
6	A/R BERG PINS	12-10087-	6
5	A/R INSULATION		5
4	A/R WIRE 26/28 AWG TWP		4
3	1 CONN BERG	12-10090-0-0	3
2	A/R CABLE COAX RG180 B/U		2
1	BURNDY MO12 MXP-17TC		1

FIRST USED ON OPTION/MODEL	QTY.	DESCRIPTION	PART NO.	ITEM NO.
PARTS LIST				
UNLESS OTHERWISE SPECIFIED DIMENSION IN INCHES. TOLERANCES				
DECIMALS	ANGLES			
.xxx = .005	± 0° 30'			
xx = .02				
x = .1				
REMOVE BURRS AND BREAK SHARP CORNERS SURFACE QUALITY ✓				
MATERIAL	NEXT HIGHER ASSY.			
FINISH	SCALE SHEET 1 OF 1			
SIZE CODE		NUMBER		REV.
DUA		BCOIW-0-0		A

REV	CHANGE NO.	DATE
1	BCOIW-0001 A	7-14-72
2	SMITH	

DEC FORM NO DRD 100-A

SIZE CODE NUMBER DUA BCOIW-0-0 REV A

This drawing and specifications, herein, are the property of Digital Equipment Corporation and shall not be reproduced or copied or used in whole or in part as the basis for the manufacture or sale of items without written permission.

<b>DIGITAL EQUIPMENT CORPORATION</b>						
MAYNARD, MASSACHUSETTS						
<b>ENGINEERING SPECIFICATION</b>					DATE 1 July 71	
TITLE SYNCHRONOUS MODEM INTERFACE DP8-EA/EB						
REVISIONS						
REV	DESCRIPTION	CHG NO	ORIG	DATE	APPD BY	DATE
A	<del>      </del>	M839-0002A	B. SMITH	4/72	<i>[Signature]</i>	4-72
B	ECO CHANGE	DP8E-00002	B. SMITH	7/72	<i>[Signature]</i>	7-72
C	ECO CHANGE	DP8E-00003	B. SMITH	10/72	<i>[Signature]</i>	11-72
ENG	R. M. SMITH	APPD	<i>[Signature]</i>	2-18-72	SIZE	A
					CODE	SP
					NUMBER	DP8-E-1
					REV	C

<b>ENGINEERING SPECIFICATION</b>	0191131	CONTINUATION SHEET
TITLE SYNCHRONOUS MODEM INTERFACE - DP8-EA/EB		
TABLE OF CONTENTS		
1.0 DESCRIPTION		
2.0 SPECIFICATIONS		
2.1 Modem Interface		
2.2 Transfer Mode		
2.3 Character Parameters		
2.3.1 Bits Per Character		
2.3.2 Baud Rate		
2.4 Data Transfers		
2.5 Control Transfers		
2.6 Clocks		
2.7 Device Codes		
2.8 Options		
2.9 Cycle Time		
2.10 Response		
2.10.1 Data Transfers		
2.10.2 Program Interrupts		
2.11 Break Priority		
2.12 Character Recognition		
2.13 Power Consumption		
2.13.1 M839		
2.13.2 M866		
2.14 Access Address		
2.15 Synchronizing Character		
2.16 Modem Compatability (Typical)		
2.17 Carrier Detection		
3.0 PROGRAMMING		
3.1 Bit Assignments and/or Description		
	SIZE	CODE
	A	SP
	NUMBER	DP8-E-1
	REV	C

**ENGINEERING SPECIFICATION**

CONTINUATION SHEET

TITLE SYNCHRONOUS MODEM INTERFACE - DP8-EA/EB

- 3.1.1 Status
- 3.1.2 Access Address
- 3.1.3 Word Count and Current Address
- 3.1.4 Transmit and Receive Data
- 3.1.5 Control Word
- 3.1.6 Character Recognition
- 3.1.7 Field Selection
- 3.1.8 Character Detected (SRCD)

3.2 Instructions

- 3.2.1 Detailed
- 3.2.2 Summary

4.0 MISCELLANEOUS

- 4.1 Test Procedure
- 4.2 DP8-E Terminated Modem Leads (301, 303, 201)
- 4.3 DP8-E Assembly
- 4.4 Jumper Selection
- 4.5 Flow Charts

- 4.5.1 DP8-E Break Cycle
- 4.5.2 Programming

4.6 Top Connectors and I/O Pin Assignments

APPENDIX

- A. RS232C Electrical Specifications
- B. Current Mode Electrical Specifications
- C. RS232C Interface Pin Assignments
- D. RS232C to CCITT Equivalent Chart

SIZE A	CODE SP	NUMBER DP8-E-1	REV C
-----------	------------	-------------------	----------

**ENGINEERING SPECIFICATION**

CONTINUATION SHEET

TITLE SYNCHRONOUS MODEM INTERFACE -DP8-EA/EB

1.0 DESCRIPTION

The DP8 is a Synchronous Modem Interface which provides facilities for Modem Control, Parallel-to-Serial -- Serial-to-Parallel Data Conversion, Level Conversion, Character Detection and a program controlled Interface to the PDP8/E.

Data exchange between the PDP and the DP8 is accomplished via the Data Break facility and takes place in parallel while data between the DP8 and the Modem are in serial.

The Synchronous Modem Interface, as an assembly, consists of two quad modules (M839 and M866), and a cable terminated by a modem connector.

The DP8 Assembly may be programmed (by instruction and/or jumper selection) for Device Code, Character Detection, access address location, Character Length, Clock Phase, Data Break Priority, Carrier on and/or Off Detection, Sync Code, Data Field (to 32K) and for: current mode (as 301 and 303 Modems), Bi-polar (EIA/CCITT), and TTL level conversion. Additionally, there are provisions for accomodating an external clock.

2.0 SPECIFICATIONS

2.1 Modem interface: Designed to accomodate Bell 201, 301 and 303 Series Modems or equivalent. Jumper selection provides for current mode, Bi-polar or TTL Interface.

2.2 Transfer Mode: Full Duplex or Half Duplex\*

2.3 Character Parameters:

2.3.1 Bits Per Character available are 6, 7, or 8.\*

2.3.2 BAUD Rate: 71,000 BAUD (MAX. for 4 character recognition; 85,000 BAUD for 2 character recognition; and 100,000 BAUD for Ø char recognition).

2.4 Data Transfers: Transfers are maintained via three single cycle data breaks (1.4 micro seconds each cycle) for both transmit and receive. An additional cycle is required for each special character to be tested for (receive circuits only). Transfer to and from core is accomplished in any

\*Jumper selectable.

SIZE A	CODE SP	NUMBER DP8-E-1	REV C
-----------	------------	-------------------	----------

# ENGINEERING SPECIFICATION

digital

CONTINUATION SHEET

TITLE SYNCHRONOUS MODEM INTERFACE - DP8-EA/EB

field. The word Count, Current Address, and Characters for test (Character Recognition) is located in a specified location within field Zero.

2.5 Control Transfers: Control transfers are maintained via the Data Bus. The types of control available are: Idle, Terminal Ready, Enable, Transmit Request and Transfer Field.

2.6 Clocks: The clocks are normally provided for by the Modem. The exception is anticipated by providing split lugs for insertion of a local clock at the M866 Level Converter Module.

2.7 Device Codes: The M839 is programmable for one of four Instruction Sets. Each Instruction Set is composed of two device codes and is paired as follows:

640X/641X or 642X/643X or 644X/645X or 646X/647X or 650X/651X or 652X/653X or 654X/655X or 656X/657X.

2.8 Options: The only options are cable sets to service the 201, 301 and 303 Series Modems.

2.9 Cycle Time: Single Cycle Data Break -- 1.4 Micro Seconds  
All Instructions -- 1.2 micro seconds.

2.10 Response Time

2.10.1 Data Transfers: 1/BAUD

2.10.2 Program Interrupt: One Character Time for Active Flags. (i.e. Word Count and character detected)

2.11 Break Priority: The M839 can be programmed (Jumper) for one of seven priorities. (1 through 7)

2.12 Character Recognition: The hardware will detect four (4) program selected characters. A Flag Bit, stored with the character, determines if the hardware will Flag the Program or strip the character upon detection.

SIZE	CODE	NUMBER	RFV
A	SP	DP8-E-1	C

# ENGINEERING SPECIFICATION

digital

CONTINUATION SHEET

TITLE SYNCHRONOUS MODEM INTERFACE - DP8-EA/EB

2.13 Power Consumption

2.13.1 M839 +5 1.4 Amps

2.13.2 M866 +15 .05 Amps  
-15 .105 Amps  
+5 .4 Amps

2.14 Access Address: Access Address is selected by groups of 16 locations in field zero. The selection is made by jumpers and the first address of each group is confined to 7600, 7620, 7640, 7660, 7700 and 7720. The underlined will be standard for the DP8-EA,B. See Section 3.1.2 for current address, word count and character (detection) assignments within the 16 word groups.

2.15 Synchronizing Character:

Transmit: Non-hardware function - must be part of data for transmission.

Receive: The Receive Synchronizing Character (SYNC) is jumper selected. Two or more consecutive (SYNC) characters must be received before the hardware will be activated.

2.16 Modem Compatability (Typical)

Type	Speed Baud
Bell 201A	2000
201B	2400
205B	600; 1200; 1800 (with modification for fixed speed select)
301B	40,800
303B,C	19,000 to 50,000 (Synchronous only)
Rixon FM12	1200
Rixon Sebet 48	4800
GE TDM Series	2400
Lenkurt 26C	170-2400
etc.	

2.17 Carrier Detect: Jumper selection detects carrier/AGC ON and/or OFF transitions.

SIZE	CODE	NUMBER	REV
A	SP	DP8-E-1	C

**ENGINEERING SPECIFICATION**

CONTINUATION SHEET

TITLE SYNCHRONOUS MODEM INTERFACE - DP8-EA/EB

3.0 PROGRAMMING

3.1 Bit Assignments and/or Description

3.1.1 Status: The AC assignments are as follows:  
(Assertion = True)

3.1.1.1 Status 1 (SRS1)

AC00 R-RQST: Indicates a received character is ready for transfer to core.

AC01 T-RQST: Indicates a transmit request for data.

AC02 SYNC 2: The hardware synchronized on two incoming SYNC characters.

AC03 SYNC 1: The hardware synchronized on the first SYNC character. This bit will be maintained if two consecutive SYNC characters are detected.

AC04 RECEIVE Field EMA0

AC05 RECEIVE Field EMA1

AC06 RECEIVE Field EMA2

AC07 MODEM Ready: Indicates that either interlock or data set ready is ON.

3.1.1.2 Status 2 (SRS2)

AC00 Carrier/AGC: Indicates that either the carrier or the AGC is ON.

AC02 Terminal Ready

AC03 Clear to Send

AC04 Transmit Field EMA0

SIZE	CODE	NUMBER	REV
A	SP	DP8-E-1	C

**ENGINEERING SPECIFICATION**

CONTINUATION SHEET

TITLE SYNCHRONOUS MODEM INTERFACE - DP8-EA/EB

AC05 Transmit Field EMA1

AC06 Transmit Field EMA2

AC07 Receive Data (inverted)

3.1.2 Access Address

The access address is assigned (by jumpers) in even groups of 16 addresses. The hardware utilizes a four bit counter to select eight of the sixteen addresses for word count, current address and character recognition.

The following list, in binary, is the four low order bits, as they apply to the access addresses namely 7600, 7620, 7640, 7660, 7700 and 7720.

Receive cycles	{	0000	Test Character	} Starting access address for 4 character recognition.	
		0001	Test Character		
		0010	Test Character		} Starting access address for 2 character recognition.
		0011	Test Character		
Transmit cycles	{	0100	Receive Word Count complimented	}	
		0101	Receive current address		
		0111	Transmit word count complimented		
		1000	Transmit current address		
		0110	*		
		1001	*		

SIZE	CODE	NUMBER	REV
A	SP	DP8-E-1	C

# ENGINEERING SPECIFICATION



CONTINUATION SHEET

TITLE SYNCHRONOUS MODEM INTERFACE - DP8-EA/EB

1010  
 1011 Not Used  
 1100  
 1101  
 1110  
 1111

\*Access address counter increments to these locations prior to character transfer with the PDP. When the counter is set at 0110, a Received Character has been transferred to a location specified by the Receive Current Address. When the counter is set at 1001, a character for transmit has been transferred to the DP8 from the location specified by the Transmit Current Address.

3.1.3 Word Count (WC) is a 12 bit right justified word used to count the number of words transmitted or received by the DP8. WC is the ONE's complement of the number of words desired to be transferred.

Example: 5(8) Words to be Received or Transmitted  
 Quantity                   000 000 000 101  
 Complement               111 111 111 010  
 Word Count                111 111 111 010

Current Address (CA) is a 12 bit right justified word used as a Memory Address for transferring data to or from core (receive or transmit) during Data Break functions. The Transfer Address is the CA+1. The first transfer will be from CA+1. The last transfer will be from CA + Number of Transmit.

Example: CA               111 000 111 111  
           Trans. Add 111 001 000 000 (CA+1)

Trans Address After 15(8) Trans 111 001 001 101

NOTE: Current Address will always show either the last location data was transferred to/from or one less than the next address data will be transferred from/to.

3.1.4 Transmit and Receive Data: the 6,7, or 8 bit character is right justified. When 6 or 7 bit characters are used, the remaining bits up to 8 should be negated.

3.1.5 Control Word: The AC bits vs. Control are as follows:

SIZE	CODE	NUMBER	REV
A	SP	DP8-E-1	C

# ENGINEERING SPECIFICATION



CONTINUATION SHEET

TITLE SYNCHRONOUS MODEM INTERFACE -DP8-EA/EB

AC00 Terminal Rdy  
 AC01 IDLE (1)  
 AC02 Enable (2)  
 AC03 Send ROST  
 AC04 For customer use (Write only TTL output)  
 AC05 For customer use (Write only TTL output)

1. If work count goes to zero while in IDLE mode, the Transmit Current address and Word Count will no longer be incremented and access to the last address will continue until the instruction SGTG (Transmit Go) is assigned or the IDLE Bit is negated.
2. If Enable is negated, Interrupt Request, Break in progress and Break Priority Gates are inhibited and the Break Request Flip Flop is latched in the ZERO state.

3.1.6 Character Recognition: Character recognition (detection) is accomplished for 6, 7, or 8 bit characters. The characters must be stored (see 3.1.2) right justified. When 6 or 7 bit characters are used, the remaining bits, up to 8, should be negated.

The stripping or flag generation upon character detection is dependent upon MD00. If MD00 is set to a ONE and the stored character is found to compare with the received character, further memory cycles will be terminated (i.e. the word count and current address will not be incremented and there will be no stored character). If MD00 is a ZERO and there is a character comparison, the character detected flag will be raised, the number of the recognized character will be stored for one character time in a two bit register, and the received character will be transferred to the current address +1.

Character Recognition is selectable for either 4 characters (locations zero through three) or 2 characters (locations two and three), Character recognition is also DE-SELECTABLE (no character recognition) allowing a higher speed limit by taking only 6 cycles for full duplex operation instead of 8 (with 2 char detection) or 10 (with 4 char detection) cycles.

SIZE	CODE	NUMBER	REV
A	SP	DP8-E-1	C

**ENGINEERING SPECIFICATION**

CONTINUATION SHEET

TITLE SYNCHRONOUS MODEM INTERFACE - DP8-EA/EB

3.1.7 Field Selection:

The selected field (increments of 4K of core up to 32K) combined with the current address forms a 15 bit address for transfers to and from core.

The field for character transfer is specified by program instruction (SLFL) and the contents of the AC. The field vs. AC assignments are as follows:

AC00 }  
 AC01 } **Receive** field (octal 0-7)  
 AC02 }  
 AC03 }  
 AC04 } **Transmit** field (octal 0-7)  
 AC05 }

3.1.8 Character Detected (Reading of)

When the instruction "Read Character Detected (SRCD)" is used to determine what character was detected, two bits, corresponding to the two low-order bits of the Access Address are transferred to AC10 and AC11 as follows:

AC10	AC11	Access Address (Base 2)
0	0	0000
0	1	0001
1	0	0010
1	1	0011

3.2 Instructions

3.2.1 Detailed

NOTE: All instructions are fully decoded and two device codes are required for an instruction set. Up to eight sets of instructions are available and are paired as follows:  
 640X/641X, 642X/643X, 644X/645X, 646X/647X.  
 650X/651X, 652X/653X, 654X/655X, 656X/657X.

SIZE	CODE	NUMBER	REV
A	SP	DP8-E-1	C

**ENGINEERING SPECIFICATION**

CONTINUATION SHEET

TITLE SYNCHRONOUS MODEM INTERFACE - DP8-EA/EB

INSTRUCTION

DESCRIPTION

Transmit Go (SGTT)  
 6405/6425  
 6445/6465  
 6505/6525  
 6545/6565

SGTT sets the Transmit Go Flip Flop. This instruction implies that the program is ready to transmit data (i.e. the Current Address (CA) and Word Count (WC), have been updated). Upon receipt of this instruction, provided Clear to Send (CS) has been received in response to Request to Send (RS), memory references will begin immediately. Memory references will cease only when Word Count (WC) decrements to zero (WC → 0). In this event if SGTT is not issued in one character time, the transmit line will be maintained at mark hold. Transmit Request should be asserted (SLCC instruction) and should not be cleared until two bit times after the last bit has been transmitted or 1/Baud x (bits per character +2) seconds after overflow.

Receive Go (SGRR)  
 6404/6424  
 6444/6464  
 6504/6564  
 6544/6564

SGRR sets the Receive Go Flip Flop. This instruction implies that the program is ready to receive data from the communications line, (i.e. the Current Address (CA) and Word Count (WC,)) have been updated. The hardware, upon receipt of this instruction, will begin memory references if two consecutive synchronizing characters have been recognized by the hardware on the incoming serial data line. Memory references will cease only when WC decrements to Zero (WC → 0) and SGRR is not issued in less than one character time.

Skip if Character Detected (SSCD)  
 6400/6420  
 6440/6460  
 6500/6520  
 6540/6560

The SSCD Instruction causes the program to skip the next instruction if the character detect flag is a ONE. The character detect flag is a ONE if an assembled character is found to compare one of the stored characters in one of the first four locations of the Access Address. Additionally, the SSCD Instruction clears the character detected flag. If the program is required to identify which of the four stored characters compared to the contents of the Receive Buffer, then a Read Character detected (SRCD Instruction should be utilized. See the SRCD instruction for details).

SIZE	CODE	NUMBER	REV
A	SP	DP8-E-1	C

ENGINEERING SPECIFICATION

digital

CONTINUATION SHEET

TITLE SYNCHRONOUS MODEM INTERFACE - DP8-EA/EB

INSTRUCTION

DESCRIPTION

Clear Sync  
Detect  
(SCSD)  
6506/6406/6426/6526  
6546/6446/6466/6566

Clears the "Sync Character Detection" Flip Flops. This instruction enables the programmer to initialize the sync detection circuits and clear the receive registers without initializing the modem interface.

Skip if Receive  
Word Count  
O'Flow  
(SSRO)  
6502/6402/6422/6522  
6542/6442/6462/6562

Skips the next instruction and clears the flag if the Receive O'Flow Flag is a ONE. The Receive O'Flow Flag is a ONE if during the Receive Data break sequence the Word Count (in core) overflowed.

Clear Synchronous  
Interface (SCSI)  
6501/6401/6421/6521  
6541/6441/6461/6561

Initializes all active functions in the synchronous interface.

Read Transfer  
Addr. Register  
6407/6427  
6447/6467  
6507/6527  
6547/6567

Transfers the contents of the Transfer Address Register to AC00-AC11. In use, the Transfer Address Register latches the Current Address+1 (CA+1) prior to returning it to core. During Data Transfers (Transmit or Receive) this register then becomes the 8/E's Memory Address (MA).

This instruction is primarily for diagnostic and/or program debug.

Load Control  
(SLCC)  
6412/6432  
6452/6472  
6512/6532  
6552/6572

Transfers the contents of AC00-AC05 for selecting Terminal Ready, Idle Mode, Synchronous Interface Enable, Transmit Request, and selectable functions respectively.

(AC00) Terminal Ready permits the modem to enter into the data mode.

SIZE	CODE	NUMBER	REV
A	SP	DP8-E-1	C

ENGINEERING SPECIFICATION

digital

CONTINUATION SHEET

TITLE SYNCHRONOUS MODEM INTERFACE - DP8-EA/EB

(AC01) Idle Mode allows a continuous transmission from the same location in core without program intervention. The hardware will enter the Idle Mode when the Word Count goes to ZERO. Further, the transmit current address and Word Count will no longer be incremented and access to the last address will continue until the SGTT Instruction is issued or the Idle Bit is negated.

(AC02) Interface Enable allows program interrupts and data break cycles.

(AC03) Transmit Request activates the Request to Send line. See SGTT instruction.

(AC04, AC05) are for customer use. When modem timing signals are used, one EIA (or current mode) transmitter is available to be used with AC04 or AC05.

Skip if Ring  
Flag  
(SSRG)

Skips the next instruction and clears the Ring Flag if the Ring Flag is a ONE.

6410/6430  
6450/6470  
6510/6530  
6550/6570

SIZE	CODE	NUMBER	REV
A	SP	DP8-E-1	C

**ENGINEERING SPECIFICATION**

CONTINUATION SHEET

TITLE SYNCHRONOUS MODEM INTERFACE - DP8-EA/EB

Skip if Carrier AGC Flag (SSCA) 6511/6411/6431/6531 6551/6451/6471/6571 Skips the next instruction and clears the Carrier/AGC Flag if the Flag is in the ONE state. The Carrier/AGC Flag is in the ONE state if the Carrier/AGC line has made an ON and/or OFF transition. The detected transitions are jumper selectable.

Read Status 2 (SRS2) 6414/6434 6454/6474 6514/6534 6554/6574 Transfers status to AC00-AC07. This instruction is primarily for diagnostic and/or program debug. The AC vs. Status is as follows:

AC00	Carrier/AGC	
AC01	Request to Send	
AC02	Terminal Ready	
AC03	Clear to Send	
AC04	REMA 0	} Field Select Register
AC05	REMA 1	
AC06	REMA 2	
AC07	Receive Data (inv.)	

Read Status 1 (SRS1) 6415/6435 6455/6475 6515/6535 6555/6575 Transfers status to AC00-AC07. This instruction is primarily for diagnostic and/or program debug. The AC vs. Status is as follows:

AC00	R-RQST	Receive and Transmit
AC01	T-RQST	Break Requests
AC02	Sync 2	Received "Sync"
AC03	Sync 1	Characters
AC04	REMA 0	} Field Select Register
AC05	REMA 1	
AC06	REMA 2	
AC07	Modem Ready	

Load Field (SLFL) 6413/6433 6453/6473 6513/6533 6553/6573 Transfers the contents of AC00-AC05 to the field select registers. AC03-AC05 selects the transmit field while AC00-AC02 selects the Receive Field. The selected field (increments of 4K of core -- up to 32K) combined with the current address forms a 15 bit address for data transfers to and from core.

SIZE	CODE	NUMBER	REV
A	SP	DP8-E-1	C

**ENGINEERING SPECIFICATION**

CONTINUATION SHEET

TITLE SYNCHRONOUS MODEM INTERFACE

Skip if Transmit Word Count O'Flow (SSTO) 6503/6403/6423/6523 6543/6443/6463/6563 Skips the next instruction and clears the flag if the Transmit O'Flow Flag is a ONE. The Transmit O'Flow Flag is a ONE if during the Transmit Data Break sequence the Word Count (in core) overflowed.

Skip on Bus Error (SSBE) 6416/6436 6456/6476 6516/6536 6556/6576 Skips the next instruction and clears the Bus Error Flag if the flag was in the ONE state. The Bus Error Flag will be in the One state if a Transmit or Receive Break Request has not been serviced in less than 1/BAUD time. This flag implies that the Break bus is either overloaded or is in-operative.

Read Character Detected (SRCD) 6417/6437 6457/6477 6517/6537 6557/6577 The contents of a two bit register which contains the address of the detected character is transferred to AC10 and AC11. The two bits correspond to the two low order bits of the access address where the characters for detection are stored.

Maintenance Instruction

The SRCD instruction issued when AC00 is set to a ONE causes a single clock pulse on the Maintenance Clock line to the modem. In the test configuration (Figure 1) this line is returned as the transmit and receive clocks enabling single step testing of the transmit and receive circuits.

SIZE	CODE	NUMBER	REV
A	SP	DP8-E-1	C

# ENGINEERING SPECIFICATION

digital

CONTINUATION SHEET

TITLE SYNCHRONOUS MODEM INTERFACE DP8-EA/EB

### 3.2.2 Summary of Instructions (FOR ADDITIONAL IOT CODES READ 65XX INSTEAD OF 64XX)

CODE	MNEMONIC	INSTRUCTION
6400/6420/6440/6460	SSCD	Skip if character detected
6401/6421/6441/6461	SCSI	Clear Synchronous Interface
6402/6422/6442/6462	SSRO	Skip if Receive Word Count O'Flow
6403/6423/6443/6463	SSTO	Skip if Transmit Word Count O'Flow
6404/6424/6444/6464	SGRR	Receive Go
6405/6425/6445/6465	SGTT	Transmit Go
6406/6426/6446/6466	SCSD	Clear Sync Detect
6407/6427/6447/6467	SRTA	Read Transfer Address Register
6410/6430/6450/6470	SSRG	Skip if Ring Flag
6411/6431/6451/6471	SSCA	Skip if Carrier/AGC Flag
6412/6432/6452/6472	SLCC	Load Control
6413/6433/6453/6473	SLFL	Load Field
6414/6434/6454/6474	SRS2	Read Status 2
		AC00 Carrier/AGC
		AC01 Request to Send
		AC02 Terminal Ready
		AC03 Clear to Send
		AC04 REMA 0
		AC05 REMA 1
		AC06 REMA 2
		AC07 Receive Data (Inv.)
6415/6435/6455/6475	SRS1	Read Status 1
		AC00 R-RQST
		AC01 T-RQST
		AC02 SYNC 2
		AC03 SYNC 1
		AC04 REMA 0
		AC05 REMA 1
		AC06 REMA 2
		AC07 Modem Ready
6416/6436/6456/6476	SSBE	Skip on Bus Error
6417/6437/6457/6477	SRCD	Read Character Detected
		Low Order Bits (Access Address)
		AC10 and AC11
6417/6437/6457/6477	----	Maintenance Clock
		with AC00 - ONE

SIZE A CODE SP NUMBER DP8-E-1 REV C

# ENGINEERING SPECIFICATION

digital

CONTINUATION SHEET

TITLE SYNCHRONOUS MODEM INTERFACE - DP8-EA/EB

### 4.0 MISCELLANEOUS

#### 4.1 Test Procedure

Test Connector DEC Part # 70-08372 wired as shown in Figure 4.1 coupled with the instruction SRCD issued with AC00 = ONE (maintenance clock) is used to exercise and/or test the DP8-EA,B.

The DP8-EA,B diagnostic is MAINDEC 08-DHDEA.

NOTE: THE FOLLOWING MUST BE FOLLOWED IN ORDER TO INSURE PROPER DIAGNOSTIC FUNCTIONING

CLOCK PHASE JUMPERS FOR THE RECEIVE CLOCK MUST BE INSERTED ACCORDING TO THE FOLLOWING TABLE

MODE	PHASE	NORMAL	INVERTED
*ON-LINE	NORMAL	IN	OUT
**OFFLINE	INVERTED	OUT	IN
CUSTOMER ((AS SPECIFIED BY THE CUSTOMER))***			

CLOCK PHASE JUMPERS FOR THE TRANSMIT CLOCK WILL BE INSERTED ACCORDING TO THE FOLLOWING TABLE

MODE	PHASE	NORMAL	INVERTED
*ON-LINE	NORMAL	IN	OUT
**OFFLINE	NORMAL	IN	OUT
CUSTOMER (((AS SPECIFIED BY THE CUSTOMER)))***			

\*Normal Bell 201 Modem configuration.

\*\*Diagnostic program configuration.

\*\*\*There are instances when the customer may desire a different than standard clock phase scheme, and may so specify.

SIZE A CODE SP NUMBER DP8-E-1 REV C

# ENGINEERING SPECIFICATION

CONTINUATION SHEET

TITLE SYNCHRONOUS MODEM INTERFACE - DP8-EA/EB

DP8-E Interface I/O Conn.	Cable Terminating Connector		Test Connector	
	EA/EB	DB25P	EA/EB*	DB25S Pins
Send Request	V	4	4	
Clear to Send	T	5	5	
Interlock/Data Set Ready	Z	6	6	
Send Data	F	2	2	
Received Data	J	3	3	
Maintenance Clock	FF	11	11	
Serial Clock Receive R		17	17	
Serial Clock Transmit N		15	15	
Terminal Ready	DD	20	20	
Carrier/AGC	BB	8	8	
Ring	X	22	22	
Frame Ground	UU	1	1	
Signal Ground	VV	7	7	
#For Customer Use	FF	11		
	JJ	12		

\*EB test connector and cable are tested the same as above. The pinning and test connector designation are different.  
 #TTL Output Jumper Selectable to External Clock Transmitter for EIA Output

TEST CONNECTOR  
 Figure 4-1

SIZE **A** CODE **SP** NUMBER **DP8-E-1** REV **C**

# ENGINEERING SPECIFICATION

CONTINUATION SHEET

TITLE SYNCHRONOUS MODEM INTERFACE - DP8-EA/EB

4.2 DP8-E Terminated Modem Leads

The following chart shows the modem control leads for models 201, 301 and 303 as used in the DP8-E. Unless otherwise specified the 201 levels are Bi-polar levels while the 301 and 303 are current mode.

Logic Print	Model 301 (EB)	Model 303 (EB)	Model 201 (EA)
Send Data	Send Data	Send Data	Send Data
Received Data	Received Data	Receive Data	Receive Data
Clear to Send	Clear to Send	Clear to Send	Clear to Send
Interlock/Data Set Ready	Interlock	Data Set Ready	Interlock
Carrier/AGC	Carrier On-Off	AGC Lock	Carrier on-off
Serial Clock Transmit	Serial Clock Transmit	Serial Clock Transmit	Serial Clock Transmit
Serial Clock Receive	Serial Clock Receive	Serial Clock Receive	Serial Clock Receive
Terminal Ready	Data Terminal Rdy*	Data Terminal Rdy*	Remote Control
Ring	Ring Indicator*	Ring Indicator*	Ring Indicator 1
External Timing	Serial Clock Transmit (External)	Serial Clock Transmit (External)	External Timing
Request to Send	Send Request	Send Request	Send Request

\*Bipolar

SIZE **A** CODE **SP** NUMBER **DP8-E-1** REV **C**

**ENGINEERING SPECIFICATION**

CONTINUATION SHEET

TITLE SYNCHRONOUS MODEM INTERFACE - DP8-EA/EB

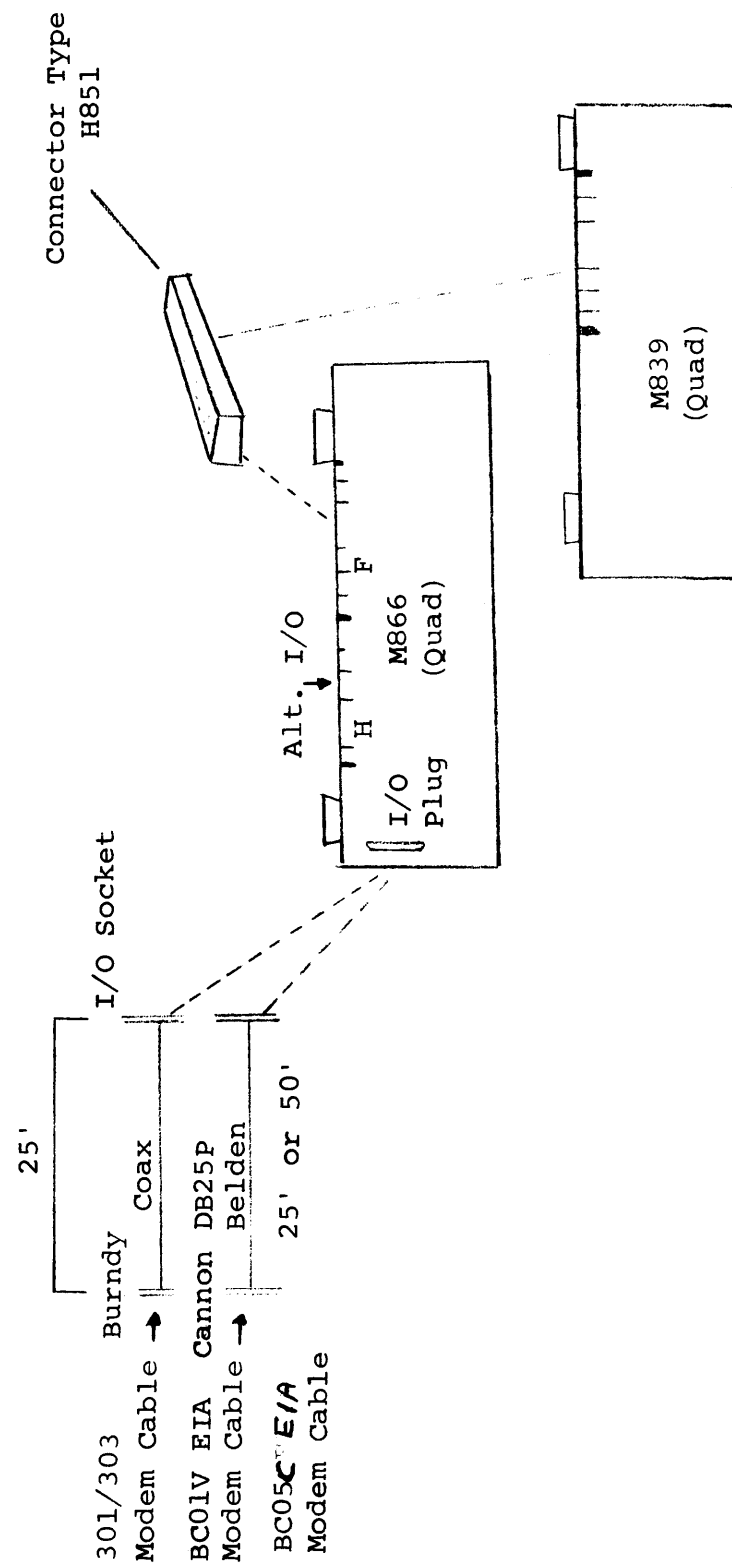

DP8-EA → EIA  
 DP8-EB → 301/303

(Assembly) --- M839 + M866 + (BC01V-25) BC05C-xx  
 (Assembly) --- M839 + M866 + BC01W-25

4.3 DP8-EA, B Assembly

SIZE	CODE	NUMBER	REV
A	SP	DP8-E-1	C

**ENGINEERING SPECIFICATION**

CONTINUATION SHEET

TITLE SYNCHRONOUS MODEM INTERFACE - DP8-EA/EB

4.4 The DP8-EA/EB modules (M839 and 866) are equipped with a number of jumpers to allow maximum freedom in configuration.

M839 Jumpers:

- A. Device codes are selectable with the jumpers labeled 5, N5, 6, 7, N6, and N7.
- B. The number of bits per character is selected with the jumpers labeled B9, B8, B78, B7, B6, C8, and C7.
- C. The Access Address is selected with the jumpers labeled A5, A6, and A7.
- D. The Break Request priority is selected by jumpers P1, P2, P3, P4, P5, P6, and P7.
- E. The Sync code is selected by jumpers labeled S4, S5, S6, S7, S8, S9, S10 and S11.
- F. Character Recognition locations are selected with jumpers 2 and 4.

M866 Jumpers:

- A. The clock Phase is selected by the two or two N jumpers.
- B. The Carrier AGC Transition is selected by the ON and OFF jumpers.
- C. Break Priority Detection is selected by the jumpers labeled P1, P2, P3, P4, P5, P6, P7.
- D. The Level Conversion selection is provided by the jumpers labeled T, CT, CE, E and C.
- E. External Timing Output is provided by jumper L.
- F. External Timing for diagnostic purposes using EIA pin 11 is provided by jumper F.
- G. Jumpers X and D provide signals necessary for auto answering with the Bell 303 modem.
- H. An internal clock is available with jumper ICL. (With cap it is set to 45000 BAUD) T = .87 (C) (220).

SIZE	CODE	NUMBER	REV
A	SP	DP8-E-1	C

**ENGINEERING SPECIFICATION**

CONTINUATION SHEET

TITLE SYNCHRONOUS MODEM INTERFACE - DP8-EA/EB

**4.4.1 Jumper Selection Guide**

Unless otherwise specified, the following selections will be made by Production:

- a. DP8-E ACCESS IOT BREAK  
A,B ADDRESS CODES PRIORITY

1st	7720-7730	640X/641X	5
2nd	7700-7710	642X/643X	4
3rd	7660-7670	644X/645X	3
4th	7640-7650	646X/647X	2

- b. 8 Bits/Character
- c. Normal Clock Phase
- d. Level conversion for DP8-EA will be EIA
- e. Level conversion for DP8-EB will be current mode.
- f. Sync code will be 226 (Octal)
- g. Carrier on/off transistions
- h. Full Duplex

**4.4.2 M839 Jumpers**

	Select	Remove Jumper
Bits/Character	6	B8, B7, B78, C7, B9,
	7	B8, B6, C8, B9
	8	B7, B6,
Break Priority (Generate)	1	P2, P3, P4, P5, P6, P7
	2	P1, P3, P4, P5, P6, P7
	3	P1, P2, P4, P5, P6, P7
	4	P1, P2, P3, P5, P6, P7
	5	P1, P2, P3, P4, P6, P7
	6	P1, P2, P3, P4, P5, P7
	7	P1, P2, P3, P4, P5, P6
Access Address	7720 (1)	A6
	7700 (2)	A6, A7
	7660 (3)	A5
	7640 (4)	A5, A7
	7620 (5)	A5, A6
	7600 (6)	A5, A6, A7
Device Code (see pg. 28) note 2	640X/641X (1)	5, 6, 7
	642X/643X (2)	5, 6, N7
	644X/645X (3)	5, N6, 7
	646X/647X (4)	5, N6, N7
Sync Code Character Recognition Locations	226	S5, S6, S8, S11 (SEE NOTE 3)
	0	2
	2	4
	4	NEITHER

SIZE CODE NUMBER REV  
A SP DP8-E-1 C

**ENGINEERING SPECIFICATION**

CONTINUATION SHEET

TITLE SYNCHRONOUS MODEM INTERFACE DP8-EA/EB

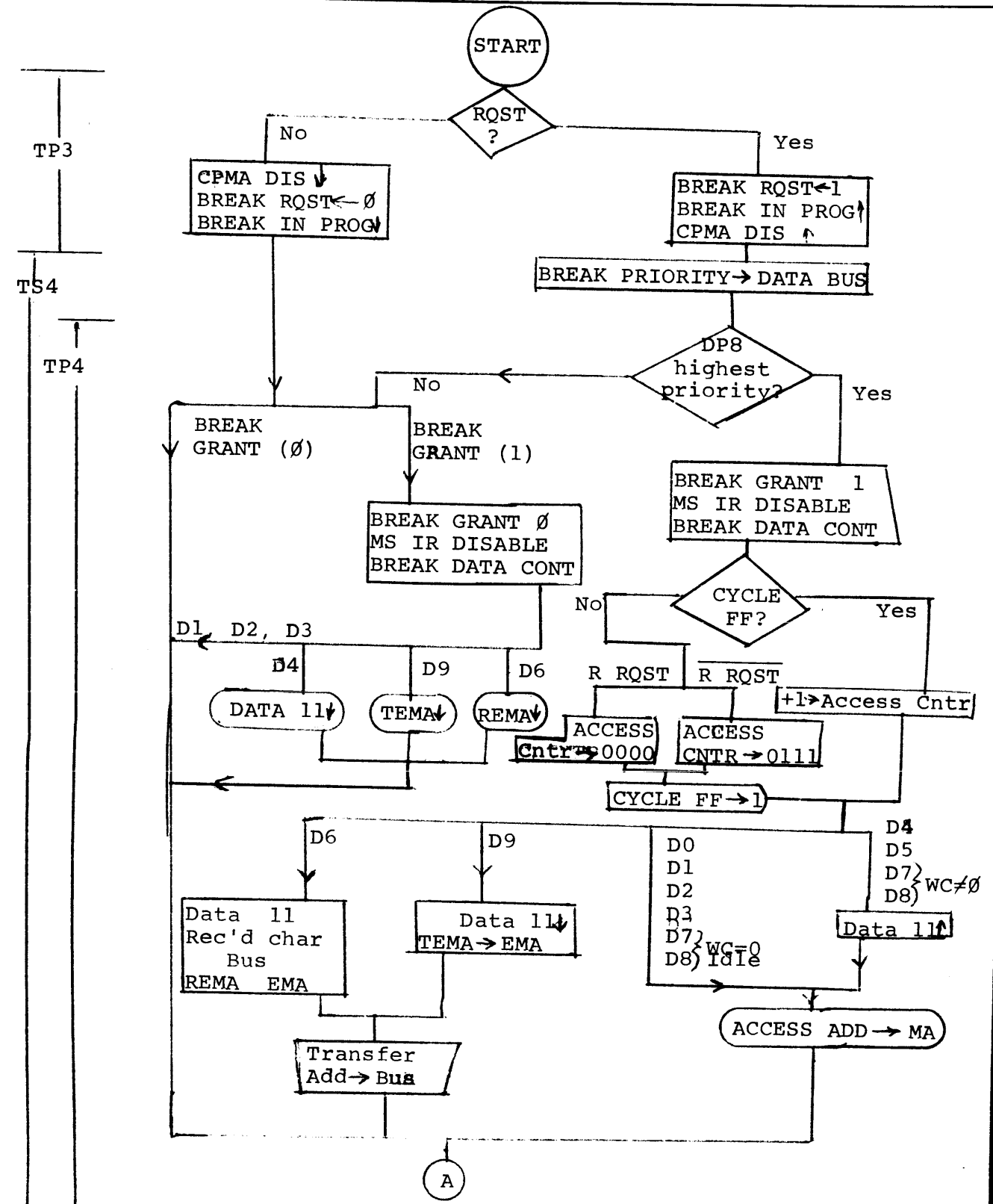

SIZE CODE NUMBER REV  
A SP DP8-E-1 C

# ENGINEERING SPECIFICATION

CONTINUATION SHEET

TITLE SYNCHRONOUS MODE INTERFACE DP8-EA/EB

NOTES: (1) 1st DP8 (2) 2nd DP8 (3) 3rd DP8  
(4) 4th DP8 (5) Spare

### 4.4.3 M866 Jumpers\*

\*Jumpers are production inserted with the exception of: C and  $\Delta$ , FF, JJ, L

	Select	Remove Jumper	Add Jumper
CO/AGC Transition	ON OFF ON & OFF	OFF ON	ON+OFF
***Clock Phase	Inverted	N(TWO)	$\Delta$ (TWO)
Level Conversion	EIA Current TTL	T, CT T, E E, CE	C(Six)
Break Priority (Detect)	1 2 3 4 5 6 7	P1 - P6 P2 - P6 P3 - P6 P4 - P6 P5 - P6 P6	
Diagnostic Test Full Duplex	Test	N (rcv) HD	$\Delta$ (Rcv)
Modem timing Bell 300 series	301 303	ICL, L X, D	X, D

\*\*\* For proper diagnostic operation the following clock jumper configuration is required:

CLOCK PHASE	TRANSMIT	RECEIVE	SYMBOL
NORMAL	XXXX		N
INVERTED		XXXX	$\Delta$

The jumpers changed to run the diagnostic program should be changed back to conform to the customers configuration (i.e. the usual configuration when using Bell modems is transmit and receive clocks both normal clock phase).

SIZE CODE NUMBER REV  
A SP DP8-E-1 C

# ENGINEERING SPECIFICATION

CONTINUATION SHEET

TITLE Synchronous modem Interface DP8-EA/EB

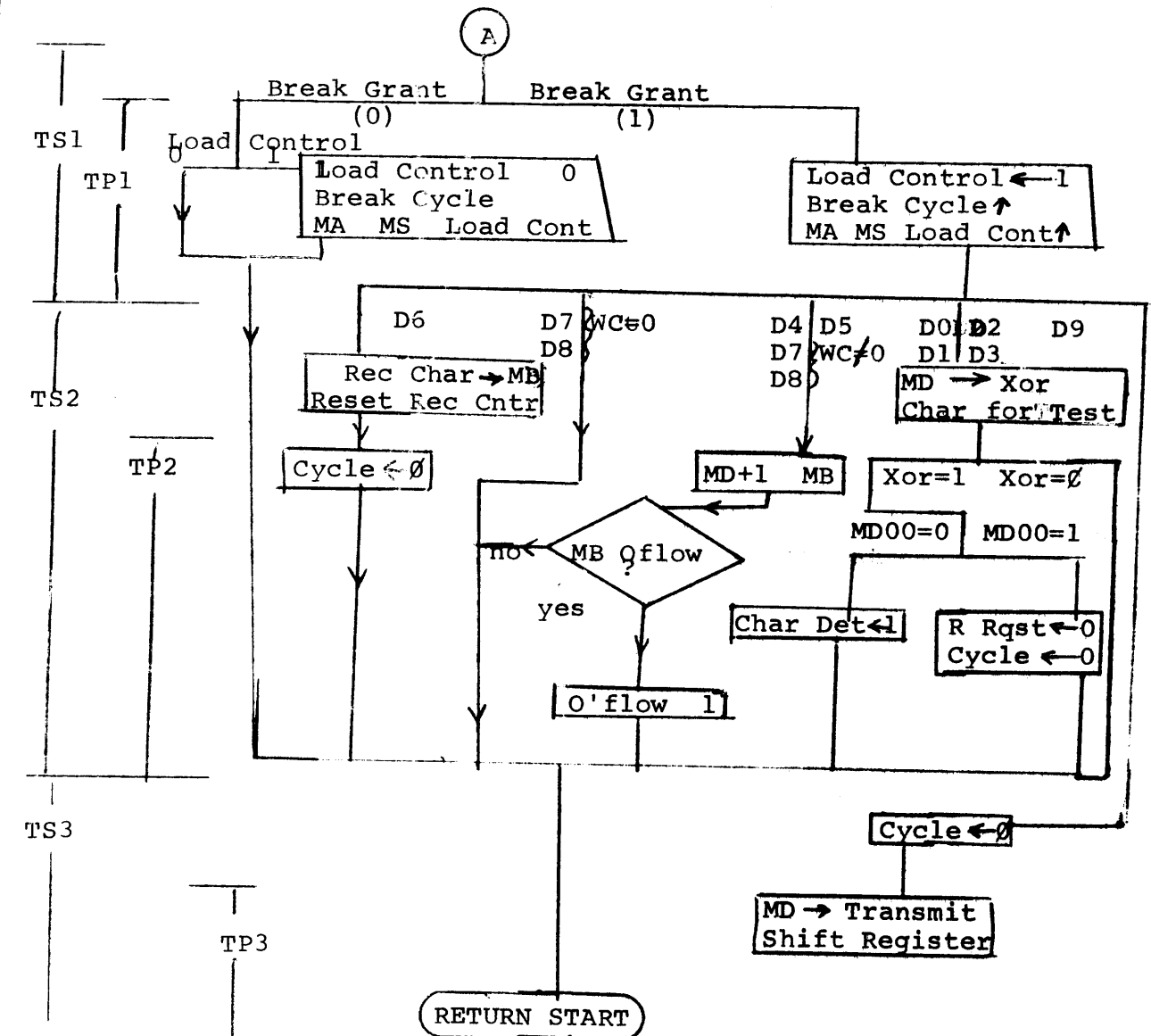

- D0-D9 refer to the addresses selected by the access address.
- Symbol meaning
  - ↑ = assertion
  - ↓ = nonassertation (cleared)
  - ↔ = goes to

SIZE CODE NUMBER REV  
A DP8-E-1 C

**ENGINEERING SPECIFICATION**

0101131

CONTINUATION SHEET

TITLE SYNCHRONOUS MODEM INTERFACE - DP8-EA/EB

4.6 Top Connector and I/O Pin Assignments

M839 M866 "F" Connector

Name	Source		Pin
	M839	M866	
SRCD (Low)		*	FA1
This Code (Inverted)	*		FB1
INT RQST	*		FC1
REC DATA (Mark +3)		*	FD1
REMA (Inverted)	*		FE1
TEMA (Inverted)	*		FF1
SCR-P (Inverted)		*	FH1
BREAK GRANT		*	FJ1
INITIALIZE (Inverted)	*		FK1
GTP4		*	FL1
BREAK RQST		*	FM1
SSBE (Inverted)		*	FN1
SCRT (Inverted)		*	FP1
CS		*	FR1
SD	*		FS1
IDLE		*	FT1
RQST	*		FU1
SRS1	*		FV1
Ground			FB2-V2
Spare			None
CNTL			FA2

Name	Edge	"H"	EIA	301	303
Signal Ground	VV	HC2	7	All	(ALL) (NOTE 1)
Frame Ground	B	HT1	1	Shields	
Clear to Send	T	HK2	5	C	C
Receive Data	J	HF2	3	K	K
Interlock/Data Set Ready	Z	HN2	6	F	F
Serial Clock XMIT	N	HH2	15	J	J
Serial Clock Receive	R	HJ2	17	L	L
Carrier/AGC	BB	HP2	8	M	M
Ring	X	HM2	22	-	F(OUTER)
Send Data	F	HE2	2	E	E
Terminal Ready	DD	HR2	20	-	M(OUTER)
Send Request	V	HL2	4	D	D
External Timing (EIA OUTPUT)	L	HH1	24	H	H
-6 Volts	-	HC1	-	-	-
+6.4 Volts	-	HS2	-	-	-
External Clock (TTL INPUT)	L	HV2	-	-	-
SEC Transmit Data	FF	-	-	-	-
SEC Receive Data	JJ	-	-	-	-

SIZE **A** CODE **SP** NUMBER **DP8-E-1** REV **C**

**ENGINEERING SPECIFICATION**

0101131

CONTINUATION SHEET

TITLE SYNCHRONOUS MODEM INTERFACE - DP8-EA/EB

NOTE 1: 303 Modem connectors F + M shields (outer connector) carry EIA signals as indicated.

NOTE 2: To allow greater flexibility IOT sets 65XX may be selected instead of/ in addition to 64XX IOT sets through the use of the 5 or N5 jumpers.

IOT SELECTED	JUMPER INSTALLED	CONFIGURATION REMOVED
650X-651X	5,N6,N7	N5,6,7
652X-653X	5,N6,7	N5,6,N7
654X-655X	5,6,N7	N5,N6,7
656X-657X	5,6,7	N5,N6,N7

NOTE 3: Remove S (number) to select A zero for that Bit .

SIZE **A** CODE **SP** NUMBER **DP8-E-1** REV **C**

**ENGINEERING SPECIFICATION**

CONTINUATION SHEET

TITLE SYNCHRONOUS MODEM INTERFACE - DP8-EA/EB

APPENDIX "A"

RS-232-C Electrical Specifications

Driver output logic levels with 3K to 7K load	15 volts $> V_{oh} > 5V$ -5 volts $> V_{ol} > -15V$
Driver output voltage with open circuit	$V_o < 25$ volts
Driver output impedance with power off	$Z_o > 300$ ohms
Output short circuit current	$I_o < 5$ amps
Driver slew rate	$\frac{dv}{dt} < 30$ volts/usec.
Receiver input impedance	7K ohms $> R_{in} > 3K$ ohms
Receiver input voltage	$\pm 15V$ compatible w/driver
Receiver output with open circuit input	Mark
Receiver output with 300 ohms to ground on input	Mark
Receiver output with +3 volt input	Space
Receiver output with -3 volt input	Mark

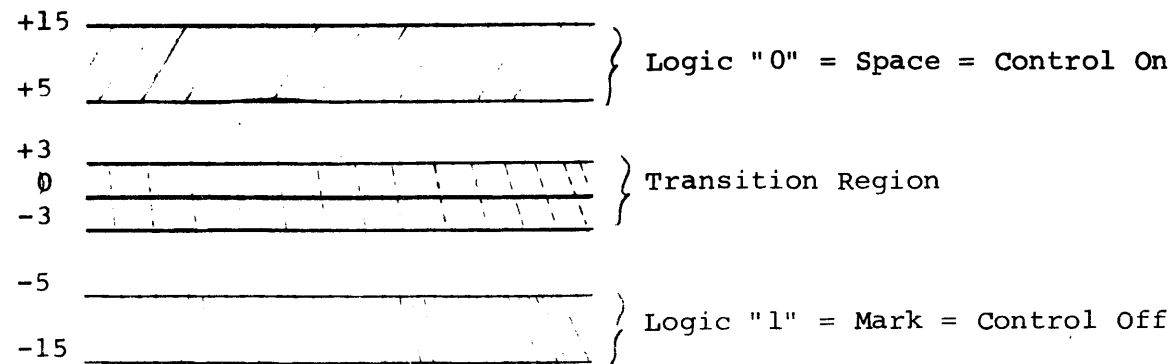

SIZE	CODE	NUMBER	REV
A	SP	DP8-E-1	C

**ENGINEERING SPECIFICATION**

CONTINUATION SHEET

TITLE SYNCHRONOUS MODEM INTERFACE - DP8-EA/EB

APPENDIX B

Current Mode Electrical Specifications (Applicable to the Bell 300 Series Modem or equivalent)

Receiver Input Current/Voltage levels with 100 ohms Termination  
Mark 5 ma ( $-0.7 < E_m < 1$ )

Driver Output Impedance with Power Off:  
Not Specified

Driver Output Short Circuit Current  
Not Specified

Driver Slew Rate between the 7 ma and the 21 ma levels  
Typical 14 ma/100 ns  
Max. 14 ma/ 50 ns  
Min. 14 ma/200 ns

Receiver Input Impedance  
 $120 > Z_{in} > 90$

Receiver Output with Open Circuit Input  
Logic one - Mark-off

Receiver Output with Input  $> 123$  ma  
Logic Zero - Space - On

Receiver Output with Input  $< 5$  ma  
Logic ONE - Mark-off

Driver Distortion Limits  
Mark to Space or Space to Mark must be achieved within 25% of bit interval.

Receiver Open Circuit Voltage  
-0.8 to -1.3

SIZE	CODE	NUMBER	REV
A	SP	DP8-E-1	C

**ENGINEERING SPECIFICATION**

CONTINUATION SHEET

TITLE SYNCHRONOUS MODEM INTERFACE - DP8-EA/EB

APPENDIX C

Pin Number	Circuit	Description
1	AA	Protective Ground
2	BA	Transmitted Data
3	BB	Received Data
4	CA	Request to Send
5	CB	Clear to Send
6	CC	Data Set Ready
7	AB	Signal Ground (Common Return)
8	CF	Received Line Signal Detector
9	--	(Reserved for Data Set Testing)
10	--	(Reserved for Data Set Testing)
11	--	Unassigned
12	SCF	Sec. Rec'd Line Sig. Detector
13	SCB	Sec. Clear to Send
14	SBA	Secondary Transmitted Data
15	DB	Transm. Signal Element Timing (DCE Source)
16	SBB	Secondary Received Data
17	DD	Received Signal Element Timing (DCE Source)
18		Unassigned
19	SCA	Secondary Request to Send
20	CD	Data Terminal Ready
21	CG	Signal Quality Detector
22	CE	Ring Indicator
23	CH/CI	Data Signal Rate Selector (DTE/DCE Source)
24	DA	Transmit Signal Element Timing (DTE/DCE Source)
25		Unassigned

EIA RS-232-C Interface Pin Assignments

SIZE	CODE	NUMBER	REV
A	SP	DP8-E-1	C

**ENGINEERING SPECIFICATION**

CONTINUATION SHEET

TITLE SYNCHRONOUS MODEM INTERFACE - DP8-EA/EB

APPENDIX D

Inter-Change Circuit	CCITT Equivalent	Description
AA	101	Protective Ground
AB	102	Signal Ground/Common Return
BA	103	Transmitted Data
BB	104	Received Data
CA	105	Request to Send
CB	106	Clear to Send
CC	107	Data Set Ready
CD	108.2	Data Terminal Ready
CE	125	Ring Indicator
CF	109	Received Line Signal Detector
CG	110	Signal Quality Detector
CH	111	Data Signal Rate Selector (DTE)
CI	112	Data Signal Rate Selector (DCE)
DA	113	Transmitter Signal Element Timing (DTE)
DB	114	Transmitter Signal Element Timing (DCE)
DD	115	Receiver Signal Element Timing (DCE)
SBA	118	Secondary Transmitted Data
SBB	119	Secondary Received Data
SCA	120	Secondary Request to Send
SCB	121	Secondary Clear to Send
SCF	122	Sec. Rec'd Line Signal Detector

EIA (RS-232-C) to Equivalent CCITT

SIZE	CODE	NUMBER	REV
A	SP	DP8-E-1	C

This drawing and specifications, herein, are the property of Digital Equipment Corporation and shall not be reproduced or copied or used in whole or in part as the basis for the manufacture or sale of items without written permission.

WIRE TABLE					
ITEM NO	DESCRIPTION	CONNECTION	CONNECTION		REMARKS
			FROM	TO	
4	24	BLK	PI-4	PI-5	
			5	6	
			2	3	
			11	17	
			17	15	
			20	22	
4	24	BLK	PI-22	PI-8	

NOTES:  
 1 EACH SOLDERED CONNECTION ON P1 SHALL BE INSULATED WITH A 1/4 INCH PIECE OF HY-SHINK TUBING (ITEM NO.2)

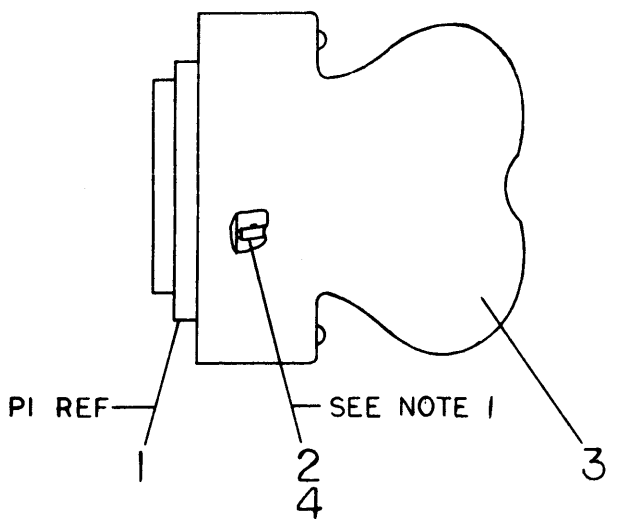

A/R	DESCRIPTION	PART NO.	ITEM NO.
	WIRE SOLID * 24 BLACK	9107470-2	4
1	CANNON CONN. HOOD DB51226-1	12-05885	3
A/R	#14 WHITE ASTRA SUFLEX HIGH SHRINK TUBING	9107255	2
1	CANNON CONN. FEMALE DB-255	12-04975	1

FIRST USED ON OPTION/MODEL DP11		QTY.		DESCRIPTION		PART NO.		ITEM NO.	
PARTS LIST									
UNLESS OTHERWISE SPECIFIED		DRN V. BISSONNETTE		DATE 3-5-71		<b>digital</b> EQUIPMENT CORPORATION MAYNARD, MASSACHUSETTS TITLE DP11-DA TEST CONNECTOR			
UNLESS OTHERWISE SPECIFIED		CHR. D. A. R. ...		DATE 3-22-71					
DIMENSION IN INCHES		ENG. R. ...		DATE 3-25-71					
TOLERANCES		PRV. ENG. J. ...		DATE 3-25-71					
DECIMALS ± .005		FRACTIONS ± 1/64		ANGLES ± 0°30'		SIZE CODE CIA 7008372-0-0			
FINAL SURFACE QUALITY REMOVE BURRS AND BREAK SHARP CORNERS		MATERIAL //		NEXT HIGHER ASS'Y A-PL-DP11-D-Ø		NUMBER		REV	
FINISH //		SCALE NONE		SHEET OF		DIST. G			

REV.	
CHANGE NO.	
DATE	

DRAWING NUMBER  
 CIA7008372-0-0

This drawing and specifications herein are the property of Digital Equipment Corporation and shall not be reproduced or copied or their use in whole or in part as the basis for the manufacture or sale of items without written permission.

WIRE TABLE															
ITEM NO.	DESCRIPTION	FROM			TO			ITEM NO.	DESCRIPTION	TO					
		AWG	COLOR	CONNECTION	WITH	CONNECTION	WITH			AWG	COLOR	CONNECTION	WITH	CONNECTION	WITH
1	22	BLU/WHT	PI-1			J1-VV		1	22	RED/BRN	PI-16			J1-NN	
		WHT/BLU	PI-2			J1-F				SLA	PI-17			J1-R	
		ORN/WHT	PI-3			J1-J				RED/SLA	PI-18			J1-U	
		WHT/ORN	PI-4			J1-V				BLU/BLK	PI-19			J1-P	
		GRN/WHT	PI-5			J1-T				BLK/BLU	PI-20			J1-DD	
		WHT/GRN	PI-6			J1-Z				ORN/BLK	PI-21			J1-MM	
		BRN/WHT	PI-7			J1-UU				BLK/ORN	PI-22			J1-X	
		WHT/BRN	PI-8			J1-BB				GRN/BLK	PI-23			J1-RR	
		SLA/WHT	PI-9			J1-Y				BRN/RED	PI-24			J1-L	
		WHT/SLA	PI-10			J1-W				RED/ORN	PI-25			J1-C	
		BLU/RED	PI-11			J1-FF				BLK	PI-1	4		J1-A	
		RED/BLU	PI-12			J1-JJ			1	22	BLK	PI-7	4	J1-B	
		ORN/RED	PI-13			J1-D			3	26	BLK	PI-1		PI-7	
		SLA/RED	PI-14			J1-LL			2	26	RED	J1-E		J1-M	
1	22	SLA/GRN	PI-15			J1-N									

NUMBER	VARIATION	
	DIM X	DIRTY (PRELUT)
BC05C-25	25±3%	25±6%
BC05C-50	50±2%	50±4%

- NOTES:
- MANUFACTURING SHOULD USE MACHINE CRIMPER TOOL FOR CRIMPING PINS (ITEM #7) MUST BE HT68 FROM BERG ELECT
  - ONLY DEC PART #1210090-0-0 MAY BE USED AS J1.
  - PLACE ITEM #9 ("THIS SIDE UP" STICKER) ON LETTERED SIDE OF ITEM #6 (BERG HOUSING) AS SHOWN.

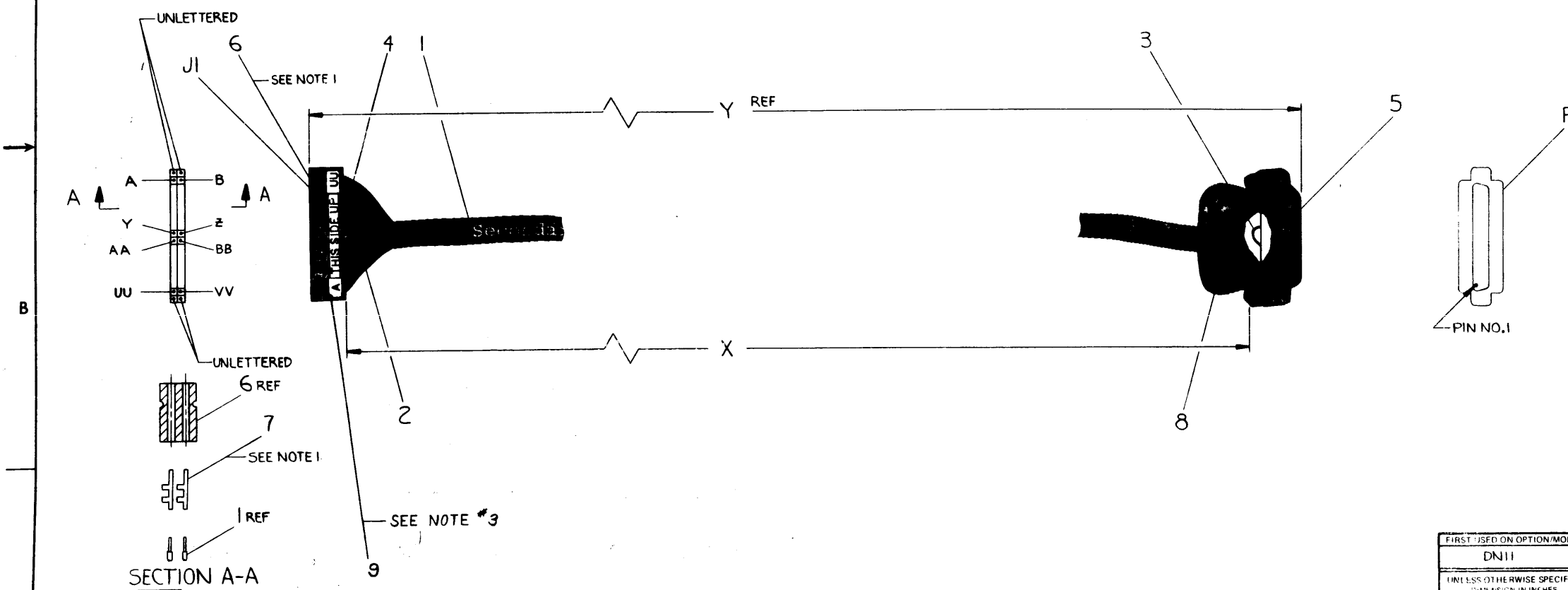

QTY	DESCRIPTION	PART NO.	ITEM NO.
1	LABEL, THIS SIDE UP	3611567	9
1	HOOD, #DB51226-1 CINCH	1205885	8
29	SOCKET, #HT-68	1210089-5	7
1	HOUSING, #20383 BERG	1210090-0-0	6
1	PLUG, #DB-25P CINCH	1205886	5
A/R	TUBING, #22 AWG TEF BLK	9107256-00	4
A/R	WIRE, #26 AWG STRD TEF BLK	9107636-00	3
A/R	WIRE, #26 AWG STRD TEF RED	9107636-22	2
A/R	CABLE, 25 CONDUCTOR	9107736	1

REV	CHANGE NO.	DATE	BY
A	BC05C-00001	7-14-72	SMITH
B	BC05C-00002	10-23-72	REGAN

FIRST USED ON OPTION/MODEL		PARTS LIST	
DN11	DESCRIPTION	PART NO.	ITEM NO.
UNLESS OTHERWISE SPECIFIED TOLERANCES	DRN <i>S. Roberts</i> DATE <i>11/21/71</i>	digital EQUIPMENT CORPORATION	
DECIMALS ANGLES	CHK <i>R. Cook</i> DATE <i>11/21/71</i>	TITLE	
XXX .005 10' 30"	ENG <i>J. L. Smith</i> DATE <i>11/21/71</i>	CABLE, MODEM	
XX .02	PROJ. ENG. <i>J. L. Smith</i> DATE <i>11/21/71</i>	BC05C	
X .05	PROD. <i>R. J. Sullivan</i> DATE <i>11/21/71</i>	SIZE CODE NUMBER REV	
MATERIAL	NEXT HIGHER ASSY.	DUA	BC05C-0-0 B
FINISH	SCALE NONE	DIST	
	SHEET 1 OF 1		



