

FUEL HANDLING		BGA-CMP-63591-016	Page 3 of 21
Rev 5	UNIT 0	RK05 – QUARTERLY PROCEDURE	

TABLE OF CONTENTS

1.0 PURPOSE/SCOPE

1.1 Purpose

1.2 Scope

2.0 REFERENCES

2.1 Flowsheets

2.2 Manuals

3.0 PREREQUISITES

3.1 Preliminary Considerations

3.2 Precautions

3.3 Isolation

3.4 Tools and Equipment

3.5 Quality Assurance

4.0 PROCEDURE

4.1 RK05 Cleaning & Inspection

4.2 RK05 Power Supply Measurements

4.3 RK05 Battery Check

4.4 RK05 Head Alignment Check

4.5 RK05 Spindle Runout Check

4.6 RK05 Index/Sector Timing Checks

4.7 RK05 Diagnostic Tests

5.0 POSTREQUISITES

FUEL HANDLING		BGA-CMP-63591-016	Page 5 of 21
Rev 5	UNIT 0	RK05 - QUARTERLY PROCEDURE	

1.0 PURPOSE/SCOPE

1.1 Purpose

1.1.1 To clean and verify proper alignment of RK05 Disk Drives.

1.2 Scope

1.2.1 To verify that the RK05 Disk Drive is operating correctly and that the power supplies are within specifications.

2.0 REFERENCES

2.1 Flowsheets

- 2.1.1 NK21-OP-0-63590-FS1 Fuel Handling Control System Block Diagram
- 2.1.2 NK21-OP-0-63590-FS2 Fuel Handling Control System Block Diagram
- South Extension

2.2 Manuals

- 2.2.1 DEC RK05 Disk Drive Maintenance Manuals
- 2.2.2 DEC. Print set.

3.0 PREREQUISITES

3.1 Preliminary Considerations

- 3.1.1 This procedure will require one man. The time required is about four hours plus two hours for each additional drive.
- 3.1.2 The RK05 Disk Drives are located in the F/H Control Equipment Rooms, MATF Control Room, Technical Building and in the F/H Maintenance Shop.

3.2 Precautions

- 3.2.1 The pins of the backplane can be easily shorted with catastrophic results. Use an insulated probe tip when measuring voltages.
- 3.2.2 The SERVO motor is powerful. Watch your fingers.
- 3.2.3 The cartridge is not a sealed unit and is extremely vulnerable to dirt, care must be taken to keep the cartridge and the interior of the drive clean.
- 3.2.4 Smoke particles, finger print smudges, or dust specks can cause head crashes.

3.3 Isolation

Not required.

FUEL HANDLING		BGA-CMP-63591-016	Page 7 of 21
Rev 5	UNIT 0	RK05 - QUARTERLY PROCEDURE	

4.0 PROCEDURE

4.1 Cleaning & Inspection

- 4.1.1 Obtain Work Authorization.
- 4.1.2 At communication printer type CTRL"C" to get you out of Fuel Handling Programme.
- 4.1.3 Halt PDP8/e Processor and select RK05's front switches to LOAD position. Remove Fuel Handling Cartridge in drive's 0 & 1 and install Diagnostic disk in drive 0. If PDP8/e was turned off you will have to reboot PDP8/e computer at this time, otherwise, load RKFRMT program into PDP8/e. Select RK05 switch to LOAD position and remove Diagnostic disk when load light comes on. Install SCRATCH disks in both drives and run RKFRMT diagnostic. If no errors occur we can assume heads are reading and writing correctly. Select RK05's to LOAD and remove disks. Turn off PDP8/e.
- 4.1.4 Remove the three screws holding the prefilter cover. Inspect and vacuum prefilter. If there is excessive dirt in the prefilter clean it with Isopropyl Alcohol or mild detergent. Make sure the filter is completely dry before reinstalling. If prefilter has started to deteriorate, replace. Pre-filters are no longer available from DEC, so we must fabricate our own using filter material MCN 812N3780.
- 4.1.5 Extend the RK05 disk drive on slide rails. Remove the top and bottom covers.
- 4.1.6 Check the inside of the bottom cover for evidence of rubbing or scraping, which could be caused by worn or distorted shock mounts. Replace shock mounts as needed.
- 4.1.7 Check all front panels LED's, if any are burnt out remove the front cover and replace. MCN 817F0164.
- 4.1.8 Check all switch operations. Replace any broken handles or sticky action. It may be necessary to adjust the front cover to prevent sticky switch action.
- 4.1.9 Ensure that the spindle brushes are mating properly and that the ground strap between the chassis and the baseplate is secure; otherwise, random data errors may result.
- 4.1.10 Inspect the logic assembly for bent or shorting pins.
- 4.1.11 Clean front panel, window and switch handles with texpads.

Head Inspection

- 4.1.12 Inspect each head using the inspection mirror. Check for the following types of contamination or damage;
 - Hydrocarbon tar-like substance on leading edge of shoe.
 - Light brown streaks on face or on trailing edge of ceramic. This indicates that the disk packs should be cleaned and inspected.
 - Heavy oxide deposit on face of head. This indicates that disk packs should be cleaned and drive air filters checked.
 - Non-particle damage, such as stains, film residue, or cracks.
 - Particle damage, such as scratches, burrs, and nicks on the face. A succession of tiny grooves indicates an embedded particle in the disk's surface which could still be present on the disk.

FUEL HANDLING		BGA-CMP-63591-016	Page 9 of 21
Rev 5	UNIT 0	RK05 - QUARTERLY PROCEDURE	

4.2 Power Supply Checks

- NOTE:**
- When checking power supply voltages (remember they are switching regulators and some ripple will be observed, 200 mV peak-to-peak maximum ripple on any of the regulators, and 250 mV peak-to-peak maximum ripple on dc voltage pins of the logic assembly).
 - Any voltage adjustments made will also affect the SERVO amplitudes signals on the servo pcb.
 - All three regulators contain current-limiting circuitry and are further protected against short circuits by a permanent 5 amp fuse. Only the +5 volt regulator contains a non-adjustable zener diode for automatic overvoltage protection.

- 4.2.1 Check the +5.0 Vdc (red wire) drive logic voltage.

Reference Point	_____	A01A2
Nominal Value	_____	+5 Vdc \pm 0.15V (4.85 to 5.15 Vdc)
Max. Pk-to-Pk Ripple	_____	250mV

NOTE: Adjust R13 on the bottom of the +5 Vdc regulator.

- 4.2.2 Check the +15.0 Vdc (orange wire) drive logic voltage.

Reference Point	_____	A02D2
Nominal Value	_____	+15 Vdc \pm 0.75V (14.25 to 15.75 Vdc)
Max. Pk-to-Pk Ripple	_____	250mV

NOTE: Adjust R17 on the bottom of the +15 Vdc regulator.

If this voltage does not meet this specification or if the +15 volt regulator was replaced, follow the 8 to 20 Volt Regulator Adjustment Procedure, Appendix A in the Bruce GSA EXT. F/H SYSTEM Maintenance Manual, Vol. 4, Part 12.

- 4.2.3 Check the -15.0 Vdc (blue wire) drive logic voltage.

Reference Point	_____	A02B2
Nominal Value	_____	-15 Vdc \pm 0.75V (-14.25 to -15.75 Vdc)
Max. Pk-to-Pk Ripple	_____	250mV

NOTE: Adjust R17 on the bottom of the -15 Vdc regulator.

If this voltage does not meet this specification or if the -15 volt regulator was replaced, follow the 8 to 20 Volt Regulator Adjustment Procedure, Appendix A in the Bruce GSA EXT. F/H SYSTEM Maintenance Manual, Vol.4, Part 12.

- 4.2.4 Using scope check for approximately 30 Vac at A04E1. If this voltage is not present an AC LOW stop signal will be generated.

FUEL HANDLING		BGA-CMP-63591-016	Page 11 of 21
Rev 5	UNIT 0	RK05 - QUARTERLY PROCEDURE	

4.4 Head Alignment Checks

4.4.1 With power OFF, connect scope channel #1 probe to TP#3 and the channel #2 probe to TP#4 on the G180 PCB (use 10:1 probes). Connect scope external trigger input to the RK05 back plane A02R2. (INDEX) (See Attachments)

4.4.2 Set the Oscilloscope controls as follows:

- Vertical Mode = ADD, Channel #1 and #2 OFF, INVERT Channel #2
- Sensitivity = 0.5V/div. (x 10 probe)
- Coupling = dc.
- Sweep time = 5 ms/div.
- Trigger = A
- Trigger mode = auto
- Coupling = ac.
- Source = external
- Slope = (-)

NOTE: • Switch Register Settings on PDP8/e:

- Handswitches should be in the down OFF position unless a specific test is being done. Any questions refer to CGE Maindec writeup on the Diagnostic procedure.
- RK05's:
Set switch labelled Run/Load to the LOAD position on all drives not being tested.

4.4.3 Power up PDP8/e with Diagnostic disk in RK05, load ALIGNX diagnostic program into computer, remove DIAGNOSTIC disk and insert the Alignment cartridge in drive. Using the WT PROT switch, place drive in the WRITE PROTECT CONDITION, and run ALIGNX diagnostic program. Operate drive in the run mode for 30 minutes to allow the cartridge and drive components to achieve thermal stabilization.

4.4.4 Ensure that the positioner track scale indicates Cylinder 00. (Paragraph 5.4.4.1, Step 8 of DEC. manual).

NOTE: • Heads are to be aligned to cylinder 105.

- X005 is the Lower head and X205 is the Upper head.
X is the drive # being tested.
- When using ALIGNX diagnostic you will notice some random noise spikes on the upper head. This is due to the program, not a problem with the drive. If it is bothersome, type Ctrl "D" to stop the continuous seek loop and the noise will disappear.

FUEL HANDLING		BGA-CMP-63591-016	Page 13 of 21
Rev 5	UNIT 0	RK05 - QUARTERLY PROCEDURE	

4.4.5 Check Bottom Head as follows:

1. At communication printer type CTRL "D" and then X005.
2. Monitor the scope display and compare it with the waveforms illustrated in Figures 2 - 5. When a head is aligned to specifications, the readback signal shows equal amplitudes for both sectors. Figure 2.
3. Calculate the percent error to determine if head is within specifications.

$$\text{percent error} = \frac{(X1 - X2) \times 100}{(X1 + X2)}$$

4. If the error is greater than 15%, it must be realigned to within 6%. If within spec. proceed to Step 4.4.6.

CAUTION

- Linear positioner carriage could move when making head adjustments. So be careful where you place your fingers on and around the carriage.
- When making a head adjustment be careful that you do not damage the Alignment disk or read/write head wires when you gently push the head tail piece back into the carriage using a screwdriver.

5. Loosen the clamp and adjustment screws and move the head in the appropriate direction until the correct waveform is obtained.
6. Tighten the clamp screw with a torque wrench of 55 in/oz. Back off the head adjustment screw slightly. The adjusting screw is a vernier that only moves the head forward; it should not be left torqued down after this adjustment. If torque wrench is not available, use the appropriate Allen wrench to tighten head clamp screw snugly; do not overtighten.
7. When head is repositioned, it could have caused the linear positioner carriage to move from Cylinder 105. So turn off the red maintenance power switch (S1 down) on the H604 PCB and manually move the positioner fully forward. Then turn on the positioner power switch (S1 up) to initiate a restore (RTZ) operation. The positioner will automatically return to cylinder 105.
8. Recheck to ensure that the clamping action did not disturb the head adjustment. If head alignment did change repeat steps 5-7 again.

4.4.6 Check Upper Head as follows:

1. At communication printer type CTRL "D" and then X205.
2. Repeat the procedure Step 4.4.5 Substep 6 for the Upper head.

FUEL HANDLING		BGA-CMP-63591-016	Page 15 of 21
Rev 5	UNIT 0	RK05 - QUARTERLY PROCEDURE	

Head slightly misaligned. Smaller left amplitude indicates head position less than CYL 105.

error = -15%

BRIGHT LINE SHOULD APPEAR HERE

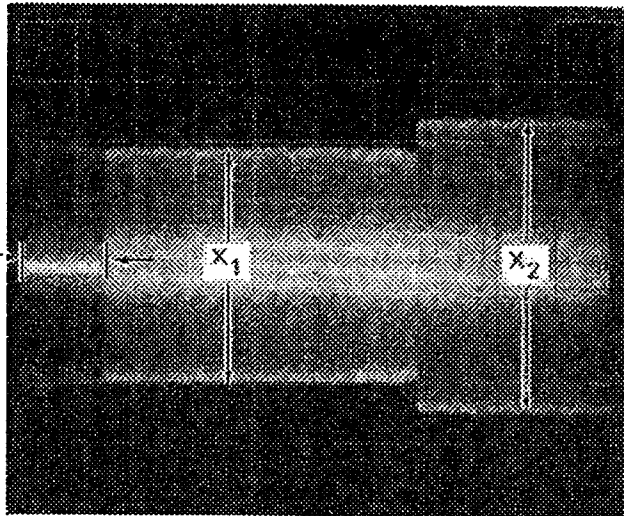

Figure 4

Extreme misalignment. Head close to CYL 104. (Further misalignment only reduces amplitude of signal on right side of screen).

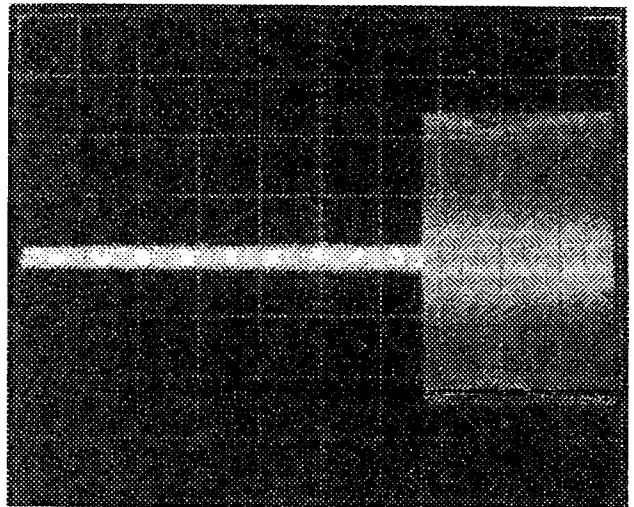

Figure 5

FUEL HANDLING		BGA-CMP-63591-016	Page 17 of 21
Rev 5	UNIT 0	RK05 – QUARTERLY PROCEDURE	

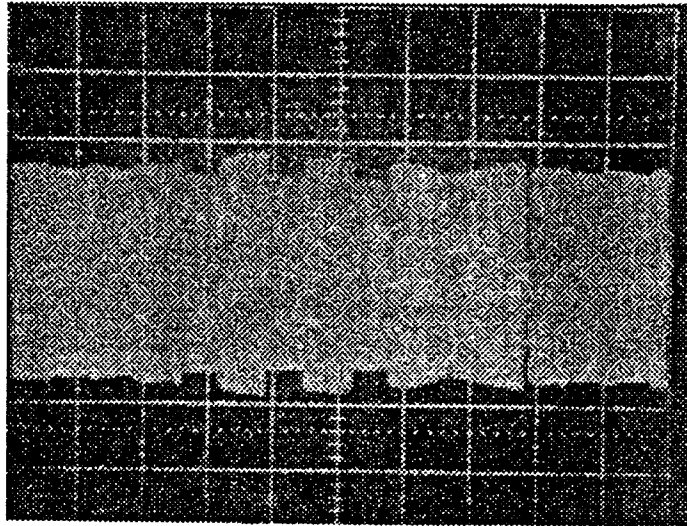

Figure 7 – Considerable Spindle Runout

4.6 Check Index/Sector Timing

NOTE: Monitor the scope for a single pulse followed by data beginning 10 μ s following the pulse. This timing pulse may be either positive or negative going. Cylinders 85 and 125 also contain this pulse, and can be used if 105 is unusable. (RK05/RK05-J only)

- 4.6.1 Expand the sweep time on the scope to 10 μ s/div and check that the single pulse occurs $70 \pm 12 \mu$ s from the start of the sweep. (Figure 8)
- 4.6.2 With the Upper head already selected from the previous step, measure the distance the single pulse occurs from the start of the sweep, as shown in Figure 8.
- 4.6.3 Select the Lower head and check for the same pulse tolerances as in Step 4.6.1. If necessary, adjust R6 on the M7680/M7700/7010516 PCB (Position 2) PCB until the average time for the two pulses is 70 μ s and the 70μ s \pm 12 μ s individual pulse requirement is maintained. If these requirements cannot be achieved, perform either of the following corrective actions:
- 4.6.4 If the time difference of the two timing pulses exceeds 24 μ s, replace one of the heads to reduce the difference. Once the difference is within tolerable limits, readjust R6 to achieve an average 70 μ s between the peaks.
- 4.6.5 If the average of the peaks cannot be adjusted to 70 μ s, relocate the sector transducer to the right (if the average is too high) or the left (if the average is too low). Readjust R6 to achieve an average 70 μ s between peaks.
- 4.6.6 Replace all modules, cables and covers. Push RK05 back into panel.

FUEL HANDLING		BGA-CMP-63591-016	Page 19 of 21
Rev 5	UNIT 0	RK05 - QUARTERLY PROCEDURE	

5.0 POSTREQUISITES

- 5.1 Install Fuel Handling disk's into RK05's.
- 5.2 Restart Fuel Handling on Process Computer according to F/H Operating Manual 4.2.2.1.
- 5.3 If PPW relay has dropped out restart Protective Computer by turning it's power switch OFF, wait 5 seconds and then back ON. The PPW (protective watchdog) relay should pick up. If computer fails to restart ref. to F/H Operating Manual Section 4.2.2.3.
- 5.4 Ensure Work Authorization is surrendered.
- 5.5 File Deficiency Report for any outstanding problems.
- 5.6 Mark up this procedure noting any errors or omissions. Forward to the Control Maintenance Coordinator.

6.0 ATTACHMENTS

6.1 Figure 1 - G180 PCB

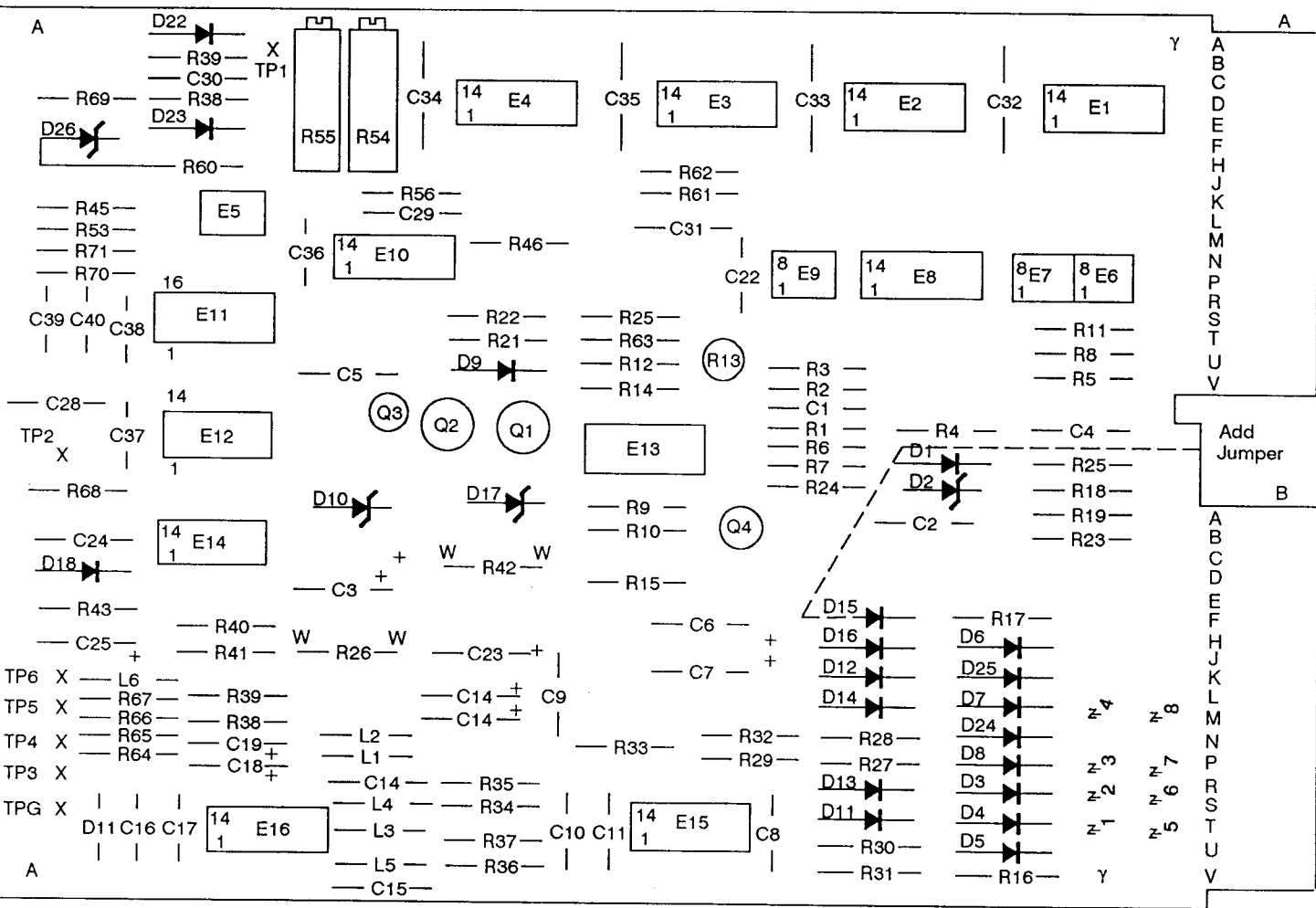

6.2 Back Plane Layout

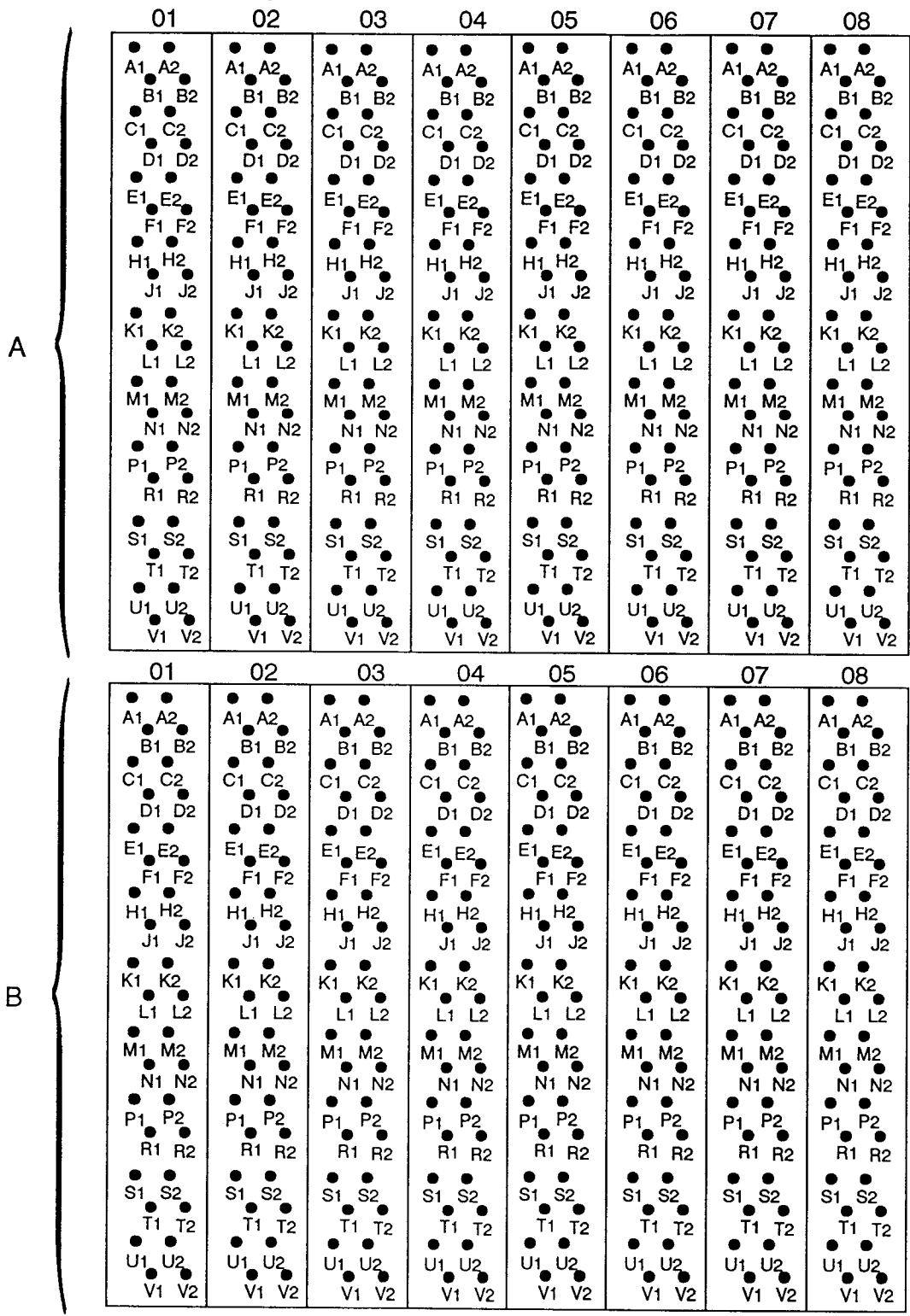

Front