



**digital**

**RX01**  
**Engineering Drawings**  
**Digital Equipment Corporation**

The material herein is for information purposes only and is subject to change without notice. Digital Equipment Corporation assumes no responsibility for any errors which may appear herein.

These drawings and specifications herein are the property of Digital Equipment Corporation and shall not be reproduced or copied or used in whole or in part as the basis for the manufacture or sale of items without written permission.  
Copyright © 1975, Digital Equipment Corporation



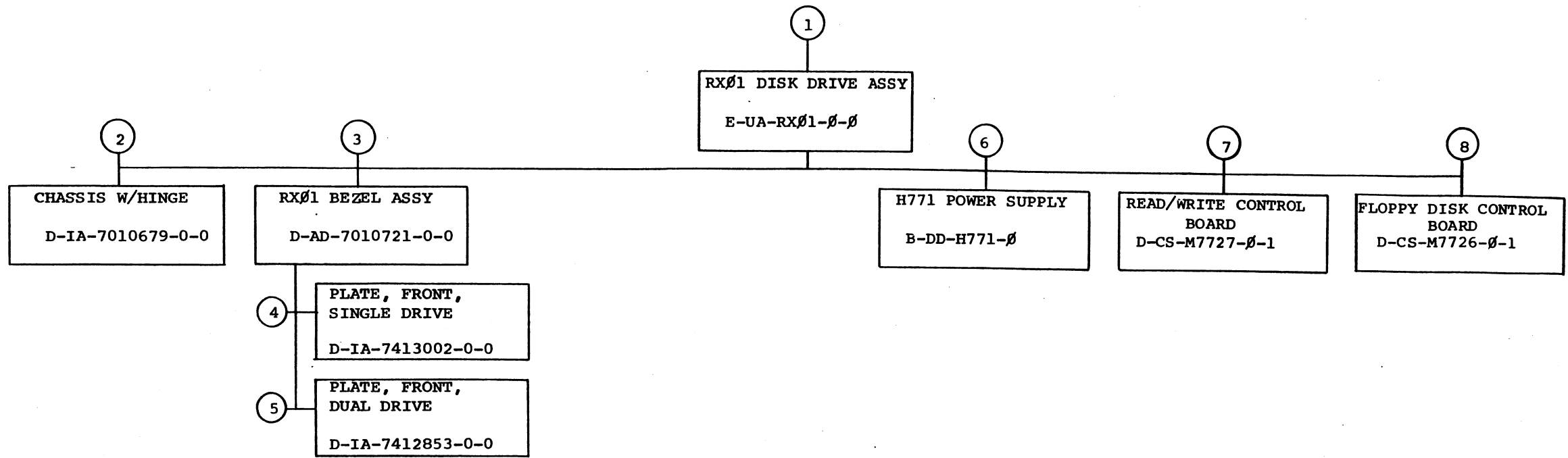

TITLE	SHEET	OF	SIZE	CODE	NUMBER	REV
RX01 FLOPPY DISK DRIVE	SHEET 2	OF 3	B	DD	RX01-0	

CUSTOMER PRINT SET		MECHANICAL					CUSTOMER PRINT SET		ELECTRICAL								
		MFG. SET	FIND NO.	DRAWING NO.	REV	NO OF SHT	DESCRIPTION	OPTION NO./FILE DATE			MFG. SET	FIND NO.	DRAWING NO.	REV	NO OF SHT	DESCRIPTION	OPTION NO./FILE DATE
			1	E-UA-RX01-0-0		5	RX01 FLOPPY DISK DRIVE ASSY		X			1	B-DD-RX01-0	#	3	RX01 FLOPPY DISK DRIVE	
				A-PL-RX01-0-0		2	RX01 FLOPPY DISK DRIVE ASSY(PI)						A-PI-3700185-0-0		2	PACKAGING INSTRUCTIONS	
				E-IA-7412666-0-0		1	COVER, TOP						A-PI-3700193-0-0			CUST. PACKAGING INSTRUCTIONS	
				D-IA-7010646-0-0		1	CABLE, EXTENSION, RX01										
				C-IA-7008612-0-0		1	CABLE, KEYBOARD										
				D-UA-BC05L-0-0		1	CABLE, JUMPER										
				D-IA-7010696-0-0		1	HARNESS, VOLTAGE VARIATION										
				C-MD-7413350-0-0		1	BRACKET, SHIPPING, RX01										
				C-MD-7409479-0-0		1	PLATE, PRESSURE										
				C-MD-5509081-0-0		1	PANEL, LIGHT (RX01)										
			2	D-IA-7010679-0-0		1	CHASSIS W/HINGE										
				E-IA-7412665-0-0		1	CHASSIS, FLEXIBLE DISK DRIVE										
				C-MD-7413236-0-0		1	HINGE, LOGIC										
			3	D-AD-7010721-0-0		1	RX01 BEZEL ASSY		X		7	D-CS-M7727-0-1	*	6	READ/WRITE CONTROL BOARD		
				E-MD-7412664-0-0		1	BEZEL, RX01					D-IA-5011370-0-0		1	ETCHED CIRCUIT BOARD (M7727)		
				A-DC-7413429-0-0		1	LOGO, RX01										
			4	D-IA-7413002-0-0		1	PLATE, FRONT, SINGLE DRIVE		X		8	D-CS-M7726-0-1	#	9	FLOPPY DISK CONTROL BOARD		
				C-SS-7413002-0-1		1	SILK SCREEN, SINGLE DRIVE					A-SP-M7726-0-7		3	ACCEPTANCE TEST PROCEDURE		
			5	D-IA-7412853-0-0		1	PLATE, FRONT, DUAL DRIVES										
				C-SS-7412853-0-1		1	SILK SCREEN, DUAL DRIVE										
C			6	B-DD-H771-0	*	3	H771 POWER SUPPLY										

CUSTOMER PRINT SET CODES  
X = PRINT OF DOCUMENT INCLUDED IN PRINT SET  
C = INCLUDES ALL PRINTS INDICATED ON DOCUMENT  
S = CONFIDENTIAL AUTHORIZED SIGNATURE REQUIRED

TITLE  
RX01 FLOPPY DISK DRIVE  
SHEET 3 OF 3  
SIZE CODE B DD  
NUMBER RX01-0  
REV

"THIS DRAWING AND SPECIFICATIONS, HEREIN, ARE THE PROPERTY OF DIGITAL EQUIPMENT CORPORATION AND SHALL NOT BE REPRODUCED OR COPIED OR USED IN WHOLE OR IN PART AS THE BASIS FOR THE MANUFACTURE OR SALE OF ITEMS WITHOUT WRITTEN PERMISSION.  
 COPYRIGHT © 1974 DIGITAL EQUIPMENT CORPORATION"

**NOTES:**

1.  $\odot$  REPRESENTS A 1/8 DIA PAD LOCATED ON SIDE 2 UNLESS OTHERWISE SPECIFIED
2. A. ALL RESISTORS ARE 1/4W,  $\pm 5\%$   
 B. ALL UNUSED PINS FOR J1 ARE TIED TO GND
3. INSTALL JUMPER W1 AFTER MODULE TEST
4. MOUNT E67 1/4" ABOVE SURFACE OF MODULE

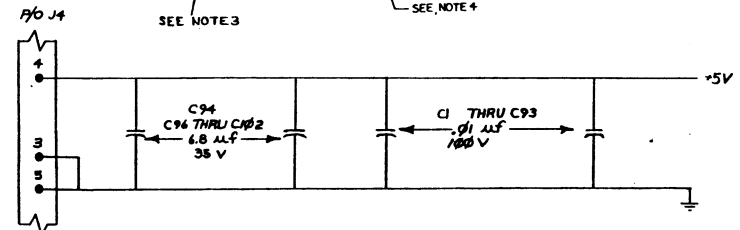
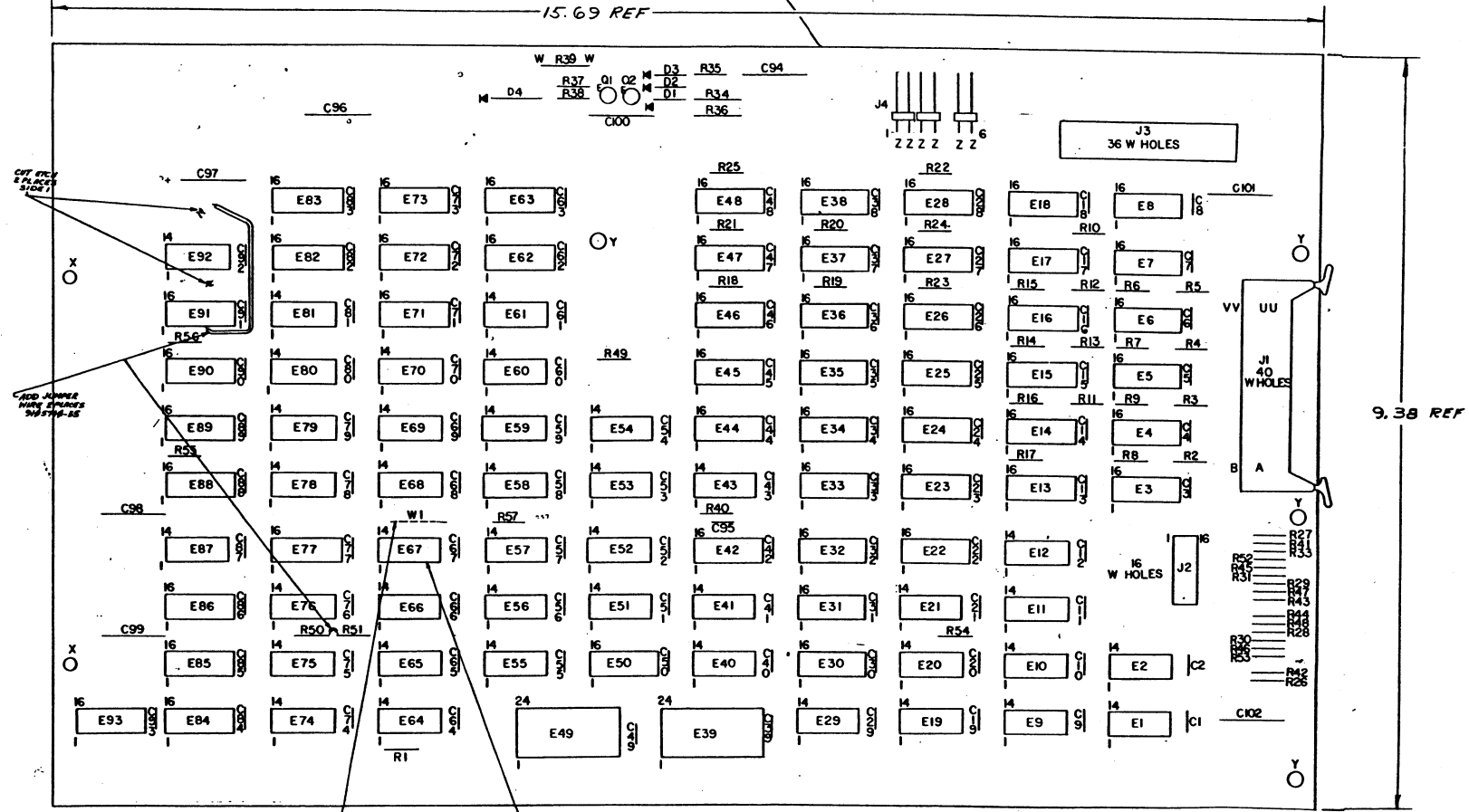

23-XYXA2	8	16
2102	9	10
8640	1	8
74175	8	16
74174	8	16
74161	8	16
74194	8	16
74123	8	16
74H103	11	4
74H106	13	5
7489	8	16
74150	12	24
7442	8	16
8266	8	16
74193	8	16
74154	12	24
IC TYPE	GND	+5V

GND AND 5V ARE USUALLY PIN 7 AND 14 RESPECTIVELY EXCEPTIONS ARE STATED ABOVE  
 IC PIN LOCATIONS

REVISIONS  
 P. KOTSCHENTHER  
 M7726-00001  
 M7726-00002  
 M7726-00003  
 M7726-00004  
 M7726-00005  
 M7726-00006  
 M7726-00007  
 M7726-00008  
 M7726-00009  
 M7726-00010

QTY	REF. DESIGNATION	DESCRIPTION	PART NO.	ITEM NO.
FIRST USED ON OPTION MODEL M7726				
ETCH BOARD REV. B				
PARTS LIST				
DATE 11/27/74 DATE 11/29/75 DATE 11/12/75 DATE 11/27/75				
digital				
TITLE FLOPPY DISK CONTROLLER				
SCALE 1 OF 9				
SEMICONDUCTOR CONVERSION CHART				
SIZE CODE NUMBER REV. D CS M7726-0-1 C				

DRAWN BY: P. KOTSCHENTHER  
 CHECKED BY: P. KOTSCHENTHER  
 DATE: 11/27/74  
 DATE: 11/29/75  
 DATE: 11/12/75  
 DATE: 11/27/75  
 DCS M7726-0-1

THIS DRAWING AND SPECIFICATIONS HEREIN ARE THE PROPERTY OF DIGITAL EQUIPMENT CORPORATION AND SHALL NOT BE REPRODUCED OR COPIED OR USED IN WHOLE OR IN PART AS THE BASIS FOR THE MANUFACTURE OR SALE OF ITEMS WITHOUT WRITTEN PERMISSION. COPYRIGHT © 1978 DIGITAL EQUIPMENT CORPORATION.

PARTS LIST

QTY	REF DESIGNATION	DESCRIPTION	PART NO	ITEM
REF		X-Y COORDINATE HOLE LOCATION	K-50-M7726-0-4	1
REF		ASSY/DRILLING HOLE LAYOUT	D-44-M7726-0-5	2
REF		MODULE ECO HISTORY	B-M-M7726-0-6	3
1		ETCHED CIRCUIT BOARD	5011390	4
1	J3	RECEP 36 PIN (BEWORK)	B-M-D-5509-07-1	5
13	J2, E3, E4, E5, E6, E7, E8, E9, E10, E11, E12, E13, E14, E15, E16, E17, E18	I.C. SOCKET, 16 PIN GOLD, LOW PROFILE	1211813-02	6
1	R37	RES 10K 1/4W 5% CC	1300479-00	7
3	C 99, C96 - C102	CAP 6.8 uF 35V 10% STANT	1005306-00	8
93	C1 - C93	CAP .01 uF 50V AXIAL CER	1001610-00	9
1	C95	CAP 12 PF 100V 5%	1002087-00	10
3	D1 - D3	DIODE 1N4004	1105796-00	11
1	D4	DIODE 1N746A 3.3V 5%	1104860-00	12
1	E 39	RES 100 1/2W 5% C.C	1300228-00	13
1	J4	HEADER, 2 PIN (MALE)	122204-00	14
8	R2, R4, R6, R8, R10, R12, R14, R16	RES 470 1/4W 5% CC	1300316-00	15
8	R27, R29, R31, R47, R52, R43, R41, R45	RES 390 1/4W 5% CC	1300309-00	16
5	R1, R49 - R51, R57	RES 3K 1/4W 5% CC	1300932-00	17
9	R22, R28, R30, R38, R42, R44, R46, R48, R53	RES 150 1/4W 5% CC	1301322-00	18
8	R3, R5, R7, R9, R11, R13, R15, R17	RES 820 1/4W 5% CC	1301775-00	19
1	R35	RES 300 1/4W 5% CC	1301925-00	20
1	R18 - R25	RES .2K 1/4W 5% CC	1302388-00	21
1	R34	RES 261 1/4W 1% MF	1302873-00	22
1	R36	RES 287 1/4W 1% MF	1305124-00	23
1	R40	RES 8.2K 1/4W 5% CC	1303179-00	24
3	R54 - R56	RES 1K 1/4W 5% CC	1300365-00	25
1	Q2	TRANS MXA805	1510705-00	26
1	Q1	TRANS MXA855	1510706-00	27
5	E19, E20, E21, E29, E40	I.C. 7474	1905547-00	28
3	E9, E57, E59	I.C. 7400	1905575-00	29
2	E93, E60	I.C. 7410	1905576-00	30
1	E75	I.C. 7450	1905580-00	31
1	E55	I.C. 74H20	1905635-00	32
1	E54	I.C. 7402	1509004-00	33
2	E68, E72	I.C. 74H00	1909056-00	34
2	E56, E70	I.C. 74H11	1909267-00	35
5	E50, E69, E78, E79, E82	I.C. 74H74	1909667-00	36
2	E64, E76	I.C. 7404	1909686-00	37
1	E39	IC 74154	1909701-00	38
2	E1, E2	I.C. 8881	1909705-00	39
1	E61	I.C. 74H04	1909931-00	40
2	E74, E92	I.C. 7486	1910011-00	41
4	E88, E89, E90, E91	I.C. 74193	1910018-00	42
2	E27, E37	I.C. 8266	1909934-00	43
1	E22	I.C. 7492	1910046-00	44
1	E65	I.C. 7437	1910091-00	45
1	E49	I.C. 74150	1910153-00	46
2	E11, E12	I.C. 7408	1910155-00	47
2	E47, E48	I.C. 7489	1910396-00	48
1	E50	I.C. 74H106	1910408-00	49
3	E80, E81, E87	I.C. 74H103	1910409-00	50
1	E42	I.C. 74123	1910436-00	51

PARTS LIST

REF DESIGNATION	DESCRIPTION	PART NO	ITEM
2	E45, E46	I.C. 74194	1910623-00 52
8	E23, E24, E25, E26, E30, E31, E32, E36	I.C. 7416	1910650-00 53
3	E84, E85, E86	I.C. 74174	1910652-00 54
1	E53	I.C. 7427	1910878-00 55
3	E28, E38, E44	I.C. 74175	1910651-00 56
2	E10, E66	I.C. 8640	1911069-00 57
1	E33	I.C. 2102	2111318-00 58
			59
6	E35, E39, E62, E63, E73, E83	SAME IC SPACES	60
1	E67	CRYSTAL OSCILLATOR 20MHZ	1811660-00 61
4	E41, E71, E93, E52	I.C. 74574	1910544-00 62
1	E51	I.C. 74H10	1909057-00 63
1	E77	I.C. 74H40	1905586-00 64
			65
NR	#30 AWG SOLID WIRE (YEL)	9108740-55	66
1	J1	CONN 40 PIN ET ANG HDR	1209941-02 67
1	(J1)	LATCH, LEFT FOR ET ANG HDE	1209941-03 68
1	(J1)	LATCH, RIGHT FOR ET ANG HDE	1209941-04 69
1	E13	I.C. 256 X 4 ROM FLD0L	23111A2 70
1	E3	I.C. 256 X 4 ROM FLD0H	23112A2 71
1	E14	I.C. 256 X 4 ROM FLD1L	23113A2 72
1	E4	I.C. 256 X 4 ROM FLD1H	23114A2 73
1	E15	I.C. 256 X 4 ROM FLD2L	23115A2 74
1	E5	I.C. 256 X 4 ROM FLD2H	23116A2 75
1	E16	I.C. 256 X 4 ROM FLD3L	23117A2 76
1	E6	I.C. 256 X 4 ROM FLD3H	23118A2 77
1	E17	I.C. 256 X 4 ROM FLD4L	23119A2 78
1	E7	I.C. 256 X 4 ROM FLD4H	23120A2 79
1	E18	I.C. 256 X 4 ROM FLD 5L	23121A2 80
1	E8	I.C. 256 X 4 ROM FLD 5H	23122A2 81
1	R33	RES 150 1/4W 5% CC	1300250-00 82

SAME I.C. GATES

TYPE	LOCATION	PINS	DESCRIPTION
74H04	E61	12	INVERTER
7404	E64	12, 13	INVERTER
7404	E76	12, 13	INVERTER
7408	E11	6, 3, 8, 9, 10	2 INPUT AND
74H00	E72	12, 3, 9, 6, 8, 10	2 INPUT NAND
7407	E65	8, 9, 10	2 INPUT NAND BUFFER
8881	E2	8, 9, 10	2 INPUT NAND G.C.
74H10	E51	3, 4, 5, 6	3 INPUT NAND
74H40	E77	1, 2, 4, 5, 6	4 INPUT NAND BUFFER
7402	E84	4, 5, 6	2 INPUT NOR
8640	E44	2, 6, 7, 14, 15, 3, 4, 5	2 INPUT NOR INVR
7427	E53	12, 13, 15	3 INPUT NOR
7406	E92	9, 5, 6	2 INPUT NOR
7406	E74	1, 2, 3, 9, 5, 6	2 INPUT NOR
74574	E73	1, 2, 3, 4, 5, 6	DTYPE FLIP FLOP
74H106	E50	6, 2, 3, 4, 14, 15, 16	J-K FLIP FLOP
74123	E42	12, 3, 4, 13, 14, 15	ONE SHOT

ALLOWABLE SUBSTITUTIONS

PREFERRED		REPLACEMENT	
TYPE	ITEM #	TYPE	P.N.
7489	48	1910396-00	3101A 1910653-00
7489	48	1910396-00	8225 1911162-00

REVISIONS

CHK	CHANGE NO	REV.

TITLE	FLOPPY DISK CONTROLLER	SIZE CODE	DCS M7726-0-1	NUMBER		REV.	C
SCALE		SHEET	2 OF 9	DIST.			

DCS M7726-0-1

THIS DRAWING AND SPECIFICATIONS HEREIN ARE THE PROPERTY OF DIGITAL EQUIPMENT CORPORATION AND SHALL NOT BE REPRODUCED OR COPIED OR USED IN WHOLE OR IN PART AS THE BASIS FOR THE MANUFACTURE OR SALE OF ITEMS WITHOUT WRITTEN PERMISSION. COPYRIGHT © 1974 DIGITAL EQUIPMENT CORPORATION.

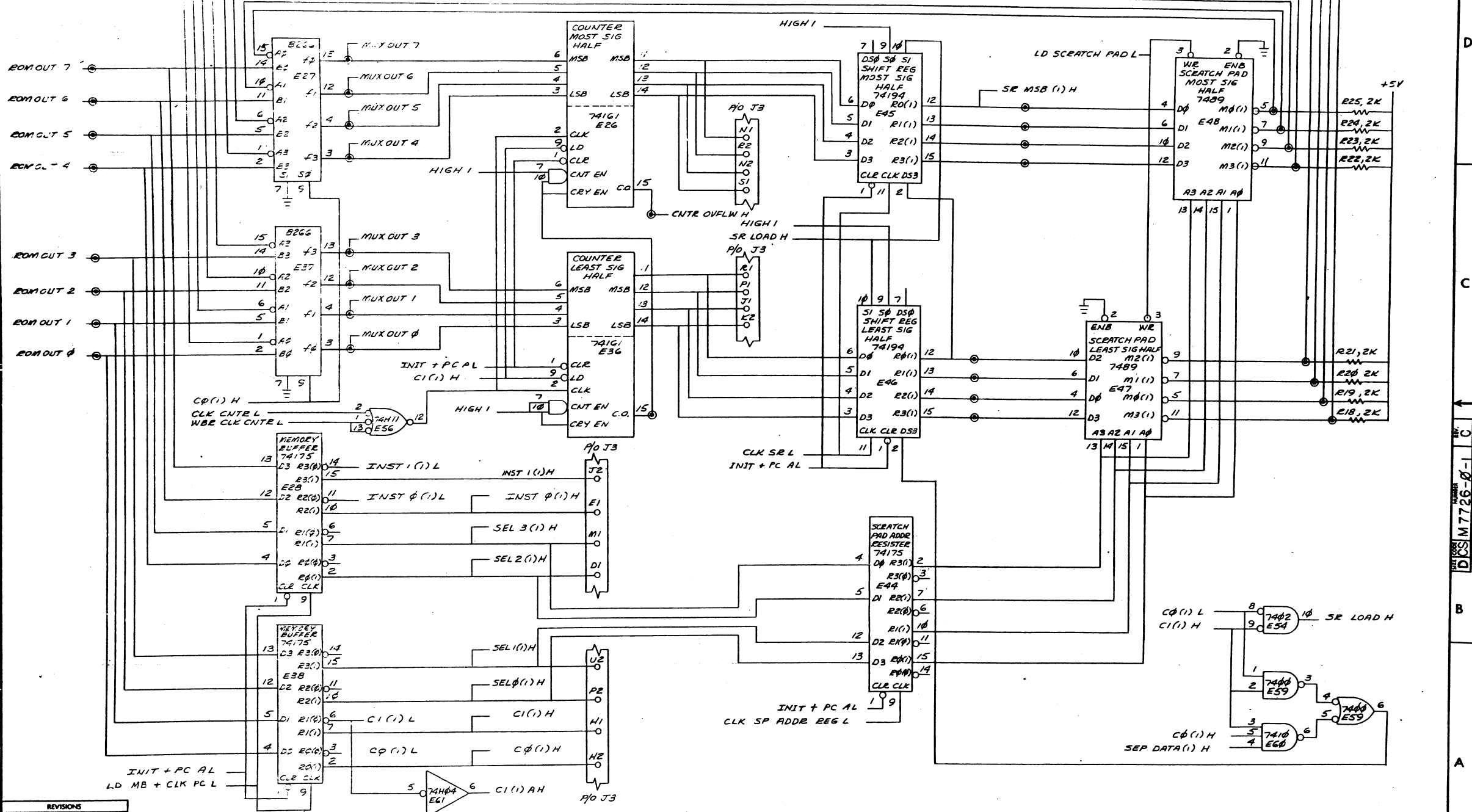

REVISIONS		
CHK	CHANGE NO.	REV.

TITLE	FLOPPY DISK CONTROLLER (D3)	SIZE CODE	DCS M7726-0-1	NUMBER		REV.	C
SCALE	SHEET 3 OF 9	DIST.					

DCS M7726-0-1 C



THIS DRAWING AND SPECIFICATIONS HEREIN ARE THE PROPERTY OF DIGITAL EQUIPMENT CORPORATION AND SHALL NOT BE REPRODUCED OR COPIED OR USED IN WHOLE OR IN PART AS THE BASIS FOR THE MANUFACTURE OR SALE OF ITEMS WITHOUT WRITTEN PERMISSION. COPYRIGHT © 1974 DIGITAL EQUIPMENT CORPORATION

DCS M7726-0-1

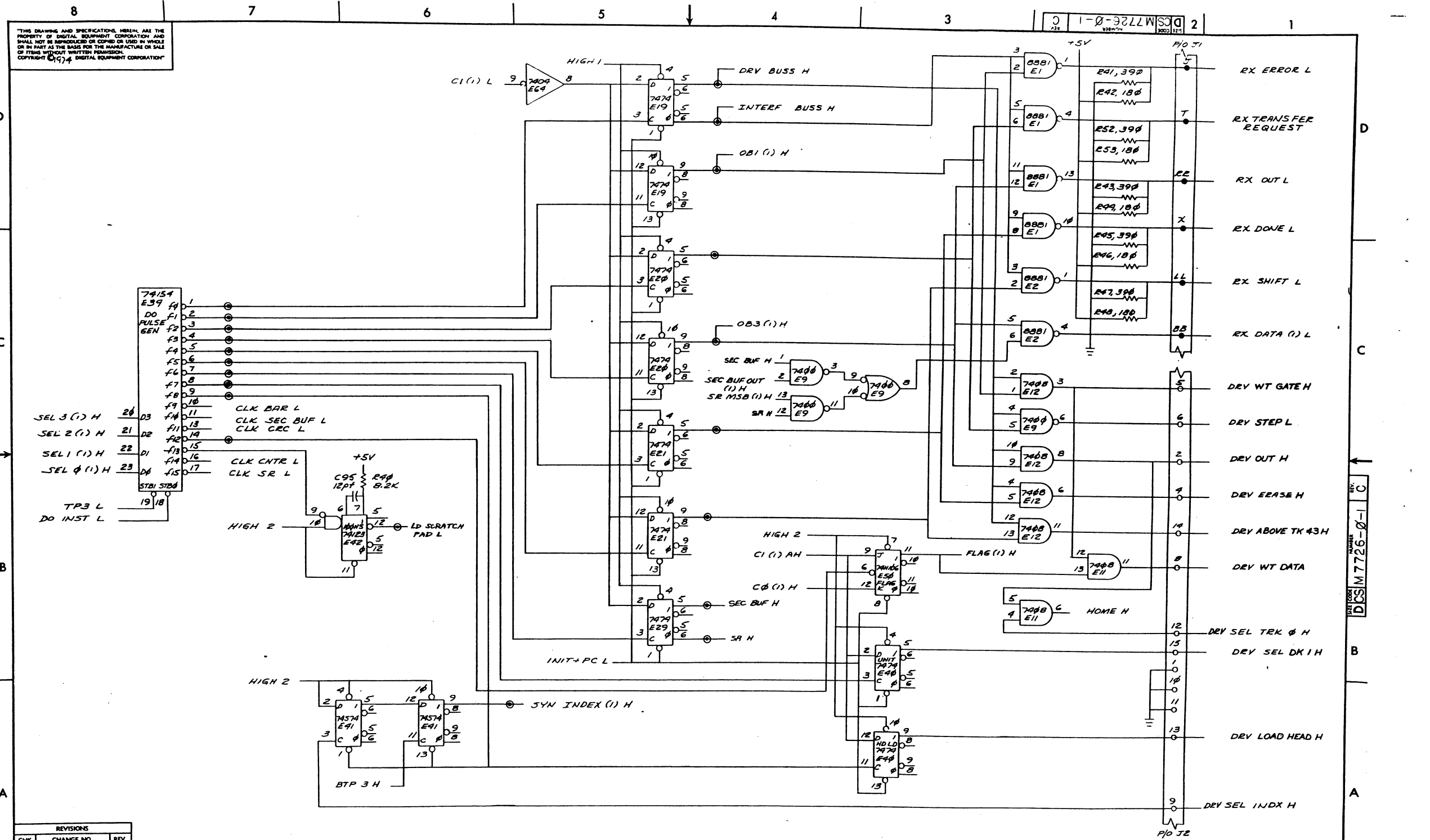

REVISIONS		
CHK	CHANGE NO.	REV.

THIS DRAWING AND SPECIFICATIONS HEREIN ARE THE PROPERTY OF DIGITAL EQUIPMENT CORPORATION AND SHALL NOT BE REPRODUCED OR COPIED OR USED IN WHOLE OR IN PART AS THE BASIS FOR THE MANUFACTURE OR SALE OF ITEMS WITHOUT WRITTEN PERMISSION. COPYRIGHT © 1974 DIGITAL EQUIPMENT CORPORATION

D  
C  
B  
A

D  
C  
B  
A

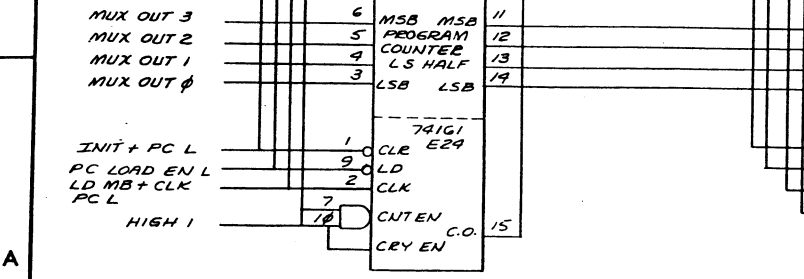
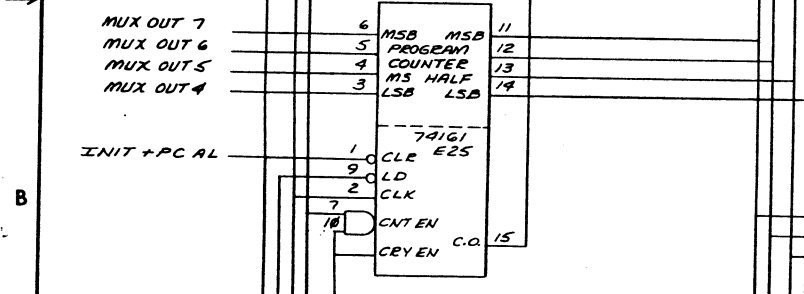
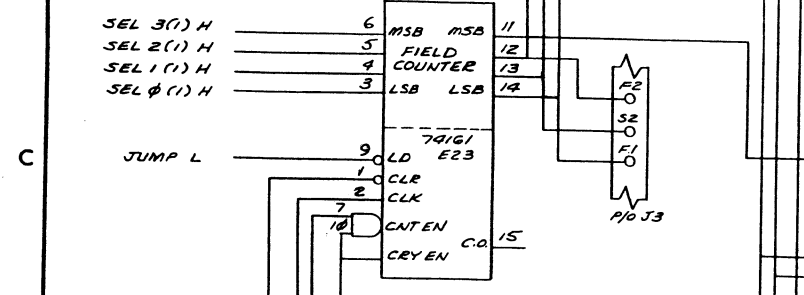
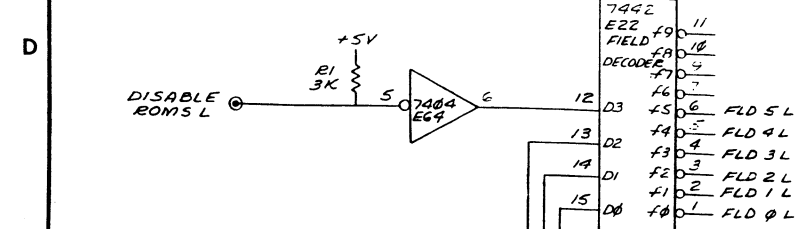

REVISIONS		
CHK	CHANGE NO.	REV.

8	7	6	5	4	3	2	1
---	---	---	---	---	---	---	---

DEC FORM NO. 980 130

THIS DRAWING AND SPECIFICATIONS, HEREIN, ARE THE PROPERTY OF DIGITAL EQUIPMENT CORPORATION AND SHALL NOT BE REPRODUCED OR COPIED OR USED IN WHOLE OR IN PART AS THE BASIS FOR THE MANUFACTURE OR SALE OF ITEMS WITHOUT WRITTEN PERMISSION. COPYRIGHT © 1974 DIGITAL EQUIPMENT CORPORATION.

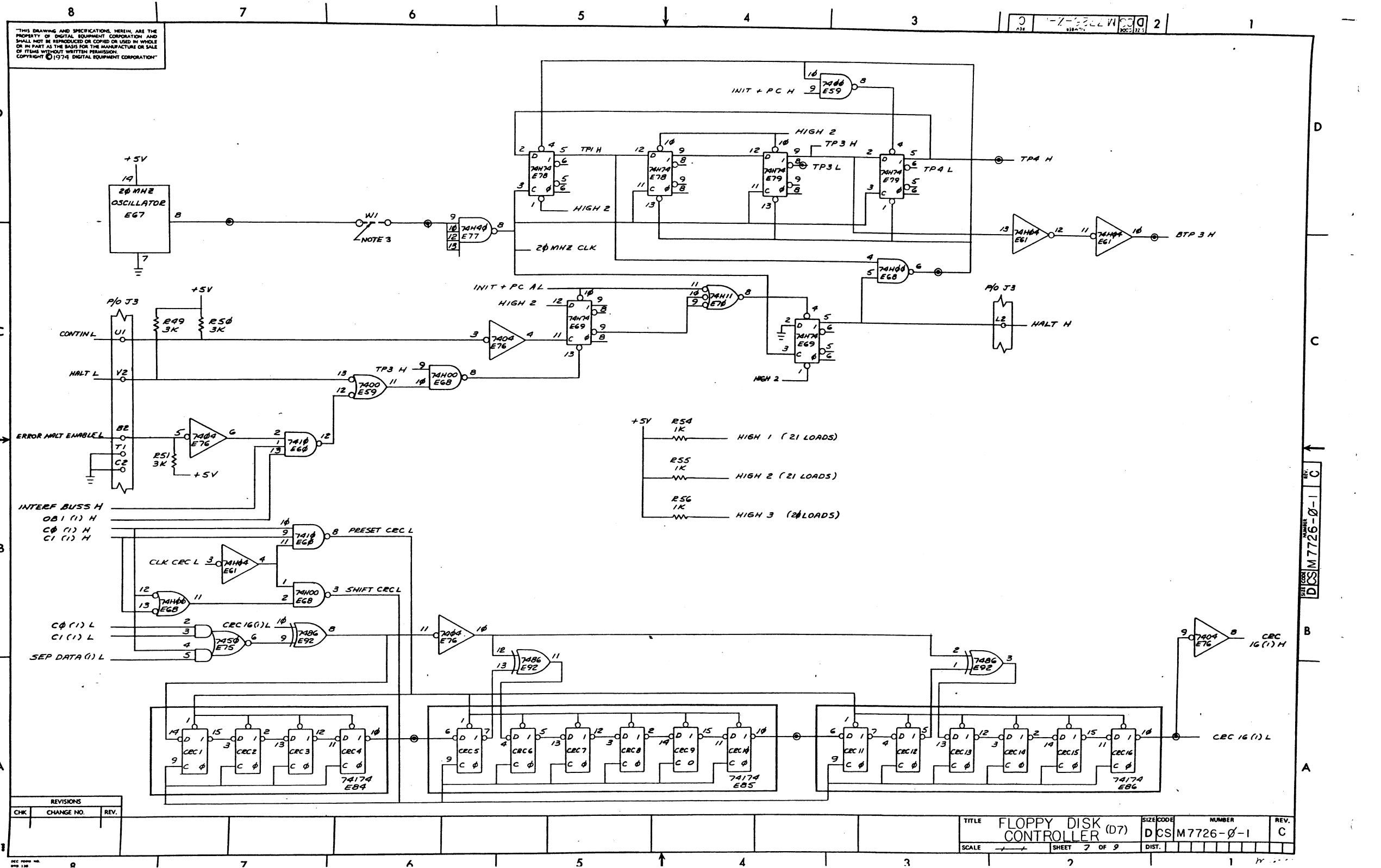

REVISIONS		
CHK	CHANGE NO.	REV.

REV. C  
 NUMBER DCS M7726-0-1  
 TITLE CODE

THIS DRAWING AND SPECIFICATIONS HEREIN ARE THE PROPERTY OF DIGITAL EQUIPMENT CORPORATION AND SHALL NOT BE REPRODUCED OR COPIED OR USED IN WHOLE OR IN PART AS THE BASIS FOR THE MANUFACTURE OR SALE OF ITEMS WITHOUT WRITTEN PERMISSION. COPYRIGHT © 1974 DIGITAL EQUIPMENT CORPORATION

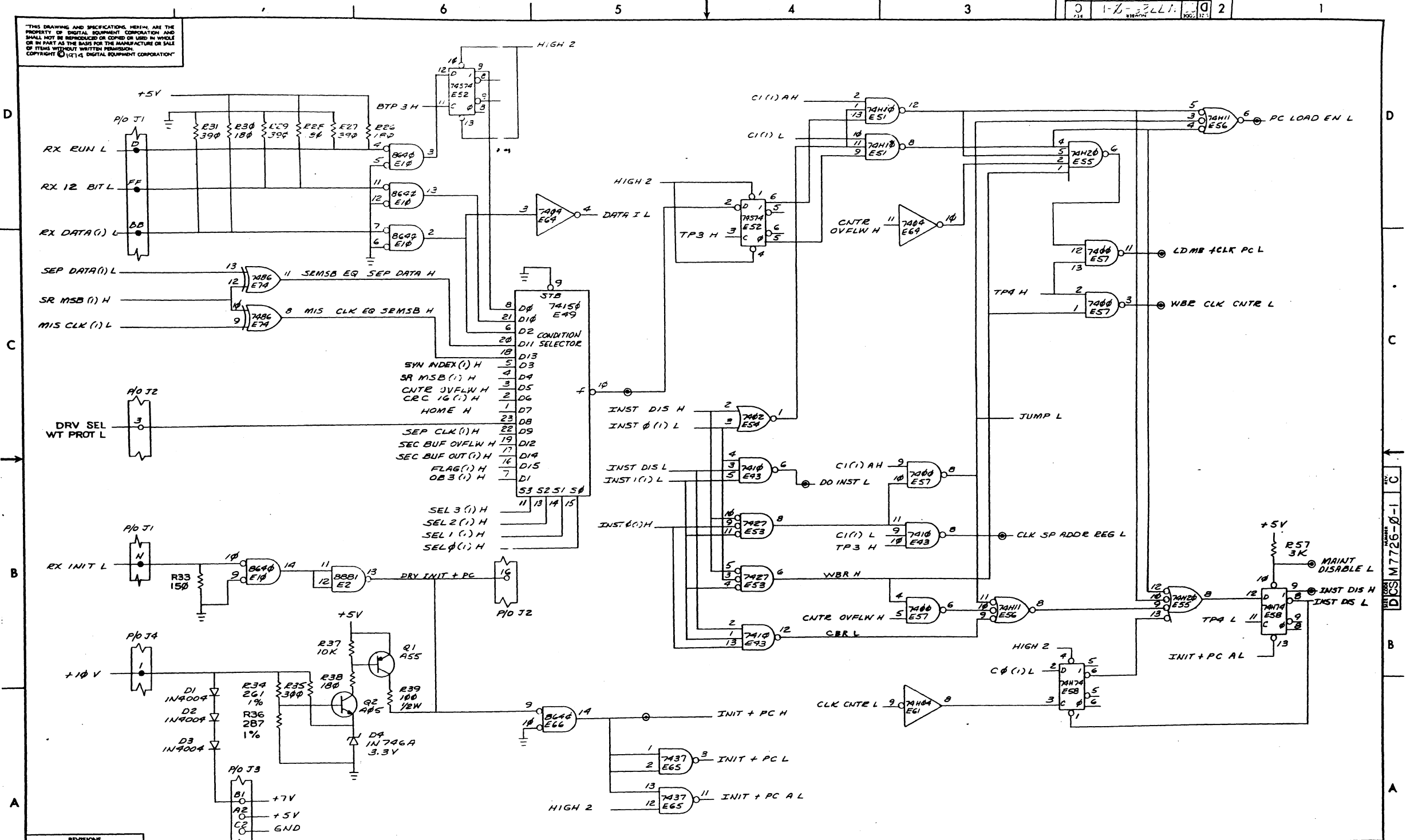

REVISIONS		
CHK	CHANGE NO.	REV.

TITLE	FLOPPY DISK CONTROLLER (DB)	SIZE CODE	NUMBER	REV.
SCALE	SHEET 8 OF 9	DIST.	DCS M7726-0-1	C

THIS DRAWING AND SPECIFICATIONS HEREIN ARE THE PROPERTY OF DIGITAL EQUIPMENT CORPORATION AND SHALL NOT BE REPRODUCED OR COPIED OR USED IN WHOLE OR IN PART AS THE BASIS FOR THE MANUFACTURE OR SALE OF ITEMS WITHOUT WRITTEN PERMISSION. COPYRIGHT © 1974 DIGITAL EQUIPMENT CORPORATION

THIS LIST GIVES THE SOURCE AND DESTINATIONS OF SIGNAL NAMES WITHIN THE M7726 PRINT SET. SIGNAL NAMES THAT DO NOT APPEAR ON THIS LIST ARE PRESENT FOR INFORMATION ONLY. THEY DO NOT INDICATE CONNECTIONS TO OTHER POINTS IN THE PRINT SET.

INTERFACE REFERS TO SIGNALS ON THE INTERFACE BUSS  
DRIVE REFERS TO SIGNALS ON THE DRIVE BUSS  
POWER SUPPLY REFERS TO VOLTAGES FROM THE POWER SUPPLY  
KN11 REFERS TO SIGNALS ON J1 THE MAINTENANCE CONNECTOR

SIGNAL NAME	ORIGIN	DESTINATION
BTP 3 H	D7-C1	D4-A5, D5-A6, D8-D6
CLK BAR L	D5-C7	D4-A3
CLK CNTR L	D5-B7	D3-B7, D8-A4
CLK CRC L	D5-C7	D7-B7
CHTR OVFLW H	D3-C5	D8-D4, D8-C6, D8-B4
CLK SEC BUF L	D5-C7	D4-B2
CLK SP ADDR REG L	D8-B3	D3-A4
CLK SR L	D5-B7	D3-B4
CORTIN L	KN11	D7-C7
CRC16 (1) H	D7-B1	D8-C6
CRC16 (1) L	D7-A1	D7-B7
C1 (1) AH	D3-A6	D4-B3, D5-B4, D8-D4, D8-C4
C1 (1) H	D3-A6	D3-C6, D3-B2, D7-B8
C1 (1) L	D3-A6	D5-D8, D7-B8, D8-D4, D8-B4
C0 (1) H	D3-A6	D3-C7, D3-A2, D4-B1, D5-B4, D7-B8
C0 (1) L	D3-A6	D3-B2, D4-B3, D7-B8, D8-B3
DATA 1 L	D8-D5	D4-A2
DISABLE ROMS L	TEST PAD	D8-B8
DO INST L	D8-B4	D5-B8
DRV BUSS H	D5-D4	D4-A4
DRV ERASE H	D5-B1	DRIVE
DRV OUT H	D5-C1	DRIVE
DRV LOAD HEAD H	D5-A1	DRIVE
DRV STEP L	D5-C1	DRIVE
DRV INIT + PC	D8-B6	DRIVE
DRV ABOVE TK 43 H	D5-B1	DRIVE
DRV RAW DATA L	DRIVE	D4-A8
DRV SEL DK 1 H	D5-B1	DRIVE
DRV SEL INDR H	DRIVE	D5-A1
DRV SEL TRK 0 H	DRIVE	D5-B1
DRV WT DATA	D5-B1	DRIVE
DRV WT GATE H	D5-C1	DRIVE
DRV SEL WT PROT L	DRIVE	D8-C8
END WIND L	D4-D3	D4-D8
ERROR HLT ENABLE L	KN11	D7-C7

DB1 (1) H	D5-D4	D7-D8
DB3 (1) H	D5-C4	D8-B6
PC 0 (1) H	D6-A1	KN11
PC 1 (1) H	D6-A1	KN11
PC 2 (1) H	D6-A1	KN11
PC 3 (1) H	D6-A1	KN11
PC 4 (1) H	D6-A1	KN11
PC 5 (1) H	D6-A1	KN11
PC 6 (1) H	D6-A1	KN11
PC 7 (1) H	D6-A1	KN11
PC LOAD EN L	D8-D1	D8-A8
RDW OUT 0	D6-D1	D3-C8
RDW OUT 1	D6-D1	D3-C8
RDW OUT 2	D6-D1	D3-C8
RDW OUT 3	D6-D1	D3-C8
RDW OUT 4	D6-D1	D3-C8
RDW OUT 5	D6-D1	D3-C8
RDW OUT 6	D6-D1	D3-C8
RDW OUT 7	D6-D1	D3-C8
RX DATA (1) L	D5-C1, INTERFACE	INTERFACE, D8-D8
RX DONE L	D5-D1	INTERFACE
RX ERROR L	D5-D1	INTERFACE
RX INIT L	INTERFACE	INTERFACE
RX OUT L	D5-D1	INTERFACE
RX RUN L	INTERFACE	D8-D8
RX SHIFT L	D5-C1	INTERFACE
RX TRANSFER REQUEST	D5-D1	INTERFACE
RX 12 HIT L	INTERFACE	D8-D8
SXC BUF OVFLW H	D4-A1	D8-C6
SXC MUF OUT (1) H	D4-C1	D5-C4, D8-B6
SXC MUF H	D5-H4	D5-C4
SFL 0 (1) H	D3-A6	D5-C8, D6-C8, D8-B6, KN11
SFL 1 (1) H	D3-A6	D5-C8, D6-C8, D8-B6, KN11
SFL 2 (1) H	D3-B6	D5-C8, D6-C8, D8-B6, KN11
SFL 3 (1) H	D3-B6	D8-C6
SEP CLK (1) H	D4-B5	D3-A2
SEP DATA (1) H	D4-B5	D4-A2, D7-A8, D8-C8
SEP DATA (1) L	D4-B5	D5-C4
SR H	D5-B4	D5-C4
SR LOAD H	D3-B1	D3-C4
SR HSB (1) H	D3-D3	D5-C4, D8-C8, D8-C6
SYM INDEX (1) H	D5-A5	D8-C6

FLAG (1) H	D5-B3	D8-B6
FLD 0 L	D6-D6	D6-A3, D6-A2
FLD 1 L	D6-D6	D6-B3, D6-B2
FLD 2 L	D6-D6	D6-C3, D6-C2
FLD 3 L	D6-D6	D6-A8, D6-A4
FLD 4 L	D6-D6	D6-B6, D6-B4
FLD 5 L	D6-D6	D6-C6, D6-C4
HALT H	D7-C3	KN11
HALT L	KN11	D7-C7
HIGH 1	D7-C4	D3-D6, D3-D4, D3-C6, D3-C4, D4-A3
HIGH 2	D7-B4	D4-B1, D5-D5, D6-A8
HIGH 3	D7-B4	D4-A5, D5-B7, D5-A7, D5-B4, D7-D5
HOME H	D5-B2	D7-D4, D7-C4, D7-C5, D8-D5, D8-B3
INIT + PC A L	D8-A4	D8-A5
INIT + PC H	D8-A4	D4-D8, D4-C8, D4-D7, D4-D5, D8-C6
INIT + PC L	D8-A4	D3-C6, D3-B4, D3-A4, D3-A7, D4-B6
INST 0 (1) H	D3-B6	D4-B5, D6-B8, D7-C5, D8-B2
INST 0 (1) L	D3-B6	D4-D5, D4-C5, D7-D4
INST 1 (1) H	D3-B6	D4-B3, D5-B5, D6-A8
INST 1 (1) L	D3-B6	KN11, D8-B5
INST DIS H	D8-B1	D8-C5
INST DIS L	D8-B1	D8-C5
INTERF BUSS H	D5-D4	D8-B5
JUMP L	D8-C3	D7-B8
LD MR + CLK PC L	D8-C1	D8-AH, D3-A8
LD SCRATCH PAD L	D5-H6	D3-H3
MAINT DIS L	TEST PAD	D8-B1
MIS CLK (1) L	D4-C4	D8-C8
MUX OUT 0	D3-C7	D5-A8
MUX OUT 1	D3-C7	D6-A8
MUX OUT 2	D3-C7	D6-A8
MUX OUT 3	D3-C7	D6-B8
MUX OUT 4	D3-C7	D6-B8
MUX OUT 5	D3-D7	D6-B8
MUX OUT 6	D3-D7	D6-B8
MUX OUT 7	D3-D7	D6-B8

TP3 H	D7-D3	D7-C6, D8-B4, D8-C5
TP3 L	D7-D3	D5-B8
TP4 H	D7-D2	D8-C3
TP4 L	D7-D3	D8-B2
WRK CLK CNTR L	D8-C2	D3-B7
20 MHZ CLK	D7-C5	D4-C8, D4-D7
GND	POWER SUPPLY	D1-A4
+5V	POWER SUPPLY	D1-A4, D8-A7
+7V	KN11	D8-A7
+10V	POWER SUPPLY	D8-B8

REVISIONS		
CHK	CHANGE NO.	REV.

TITLE	SIZE CODE	NUMBER	REV.
FLOPPY DISK CONTROLLER	D CS	M7726-0-1	C
SCALE	SHEET 9 OF 9	DIST.	

DRAWING NUMBER M7726-0-1 REV. C

THIS DRAWING AND SPECIFICATIONS HEREIN ARE THE PROPERTY OF DIGITAL EQUIPMENT CORPORATION AND SHALL NOT BE REPRODUCED OR COPIED OR USED IN WHOLE OR IN PART AS THE BASIS FOR THE MANUFACTURE OR SALE OF ITEMS WITHOUT WRITTEN PERMISSION.  
COPYRIGHT © 1974 DIGITAL EQUIPMENT CORPORATION

**NOTES:**

1. UNLESS OTHERWISE SPECIFIED:  
A. ALL RESISTORS ARE 1/4W, ±5%

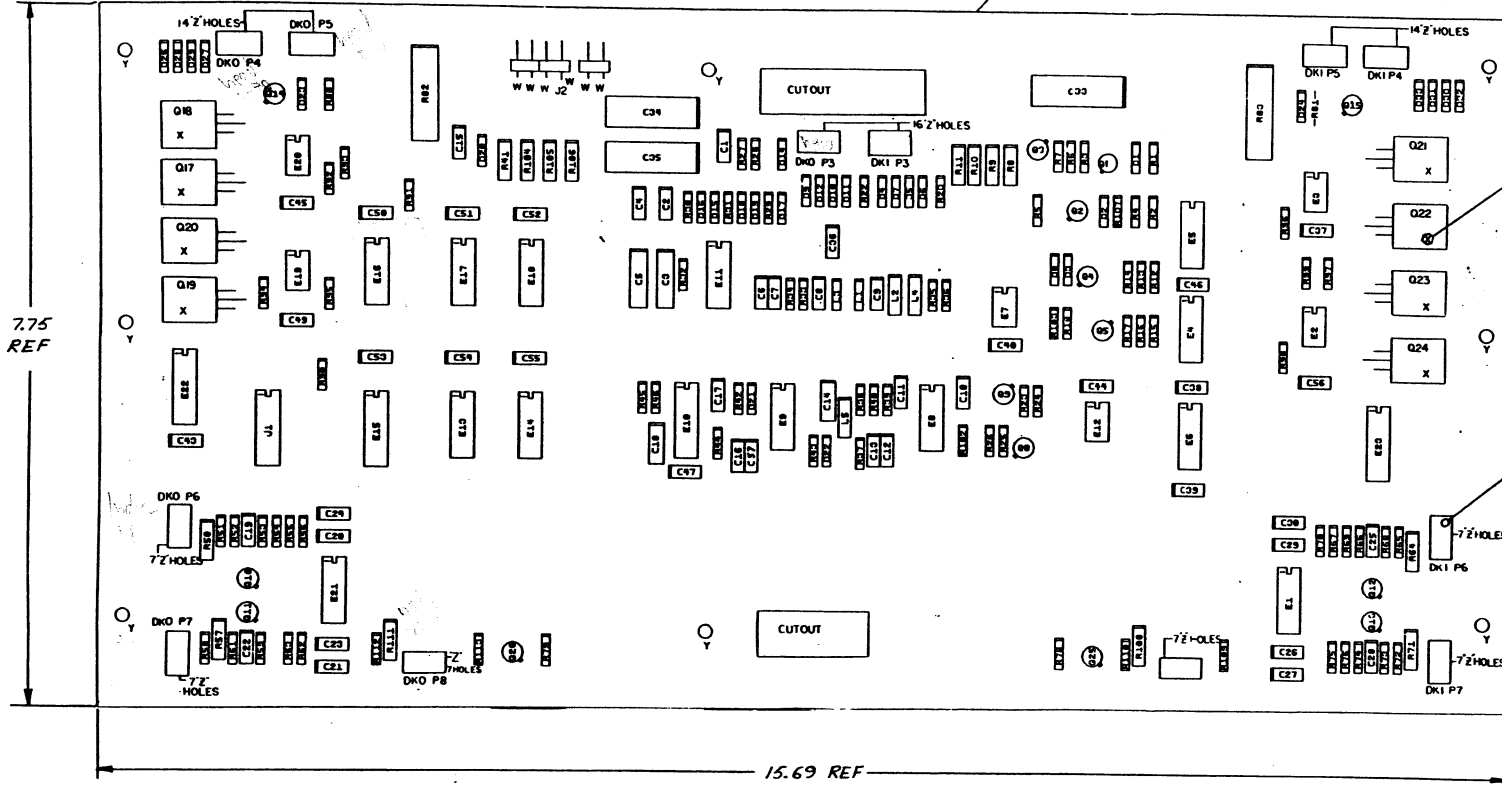

IC TYPE	QTY	REV.
7473	11	4
75451	4	8
74157	0	16
75452	4	8
74123	8	16
IC TYPE	GND	+5V

GND AND 5V ARE USUALLY PIN 7 AND 14 RESPECTIVELY EXCEPTIONS ARE STATED ABOVE

IC PIN LOCATIONS

QTY	REF. DESIGNATION	DESCRIPTION	PART NO.	ITEM NO.
FIRST USED ON OPTION MODEL				
M7727				
ETCH BOARD REV. B				
PARTS LIST				
DATE	12/21/74	DATE	12/21/74	
CHKD	V. Brown	DATE	1/20/75	
ENG	D. Anderson	DATE	2-24-75	
PROJ. MGR.	George J. ...	DATE	12/21/74	
PROD.	...	DATE	12/21/75	
TITLE				
READ/WRITE CONTROL				
NEXT HIGHER ASSY				
+				
DEC NO.	EIA NO.	DEC NO.	EIA NO.	SCALE
				1 OF 6
SEMICONDUCTOR CONVERSION CHART				
SIZE CODE	NUMBER	REV.		
D	CSM7727-0-1	A		

PART NO. DCSM7727-0-1  
 REV. A

THIS DRAWING AND SPECIFICATIONS HEREIN ARE THE PROPERTY OF DIGITAL EQUIPMENT CORPORATION AND SHALL NOT BE REPRODUCED OR COPIED OR USED IN WHOLE OR IN PART AS THE BASIS FOR THE MANUFACTURE OF SUCH OR OTHER ITEMS WITHOUT WRITTEN PERMISSION. COPYRIGHT © 1974, DIGITAL EQUIPMENT CORPORATION.

PARTS LIST

QTY	REF DESIGNATION	DESCRIPTION	PART NO.	ITEM
		X-Y COORDINATE HOLE LOCATION	K-CO-M7727-0-4	1
		ASSY/ DRILL HOLE LAYOUT	D-AM-M7727-0-5	2
		MODULE ECO HISTORY	B-MM-M7727-0-6	3
1		ETCHED CIRCUIT BOARD	D-1A-5011370-00	4
2	C17, C18	CAP 100 pf	1000016-00	5
1	C9	CAP 180 pf	1000020-00	6
2	C8, C14	CAP 220 pf	1000021-00	7
32	C1, C2, C4, C10, C11, C15 C16, C20, C21, C23, C24 C26, C27, C29, C30, C37, C38, C39, C40, C43 C44, C45, C46, C47 C49 - C57	CAP .01 μf	1001610-00	8
2	C3, C5	CAP 6.8 μf 35V	1005306-00	9
2	C34, C35	CAP 190 μf	1009433-00	10
1	C33	CAP 50 μf	1000080-00	11
4	C7, C6, C12, C13	CAP .047 μf	1010978-32	12
5	C19, C25, C22, C28, C36	CAP .005 μf	1001765-00	13
10	D4, D7, D9, D12, D14 D15, D6, D17, D18, D19	DIODE D671	1103309-00	14
8	D3, D5, D6 D8 D10 D11, D21, D22	DIODE D672	1105275-00	15
10	D23, D24, D26, D27 D28, D29, D30, D31 D32, D33	DIODE 1N4004	1105796-00	16
1	D20	DIODE 1N4742 12V	1109502-00	17
2	D1, D2	DIODE 5.1V	110713-00	18
9	R90, R92 - R99 R41, R104, R105, R106	RES 150 1/4W 5%	1300250-00	19
		RES 680 1/2W 5%	1300347-00	20
2	R6, R14, R17, R23, R24, R26, R46 R78, R79, R80, R81 R91,	RES 1K 1/4W 5%	1300365-00	21
4	R8 - R11	RES 1.2K 1/2W 5%	1300385-00	22
6	R50, R57, R64, R71, R80, R111	RES 68 1/2W 5%	1309405-00	23
7	R13, R16, R53, R62 R68, R75, R102	RES 1.5K 1/4W 5%	1300391-00	24
4	R35, R36, R39, R40	RES 511 1/8W 1%	1302411-00	25
1	R5	RES 2.74K 1/8W 1%	1304868-00	26
11	R2, R4, R7, R12, R15 R18, R23, R25, R27 R42, R43	RES 3.3K 1/4W 5%	1300439-00	27
6	R1, R20, R22, R44 R45, R107	RES 10K 1/4W 5%	1300479-00	28
11	R3, R37, R38, R52 R58, R63, R66, R72 R76, R109 R112	RES 1.21K 1/8W 1%	1302871-00	29
1	R32	RES 196 1/8W 1%	1302956-00	30
2	R33, R34	RES 464 1/8W 1%	1303047-00	31
2	R28, R29	RES 34.8K 1/8W 1%	1303156-00	32
4	R51, R61, R65, R73	RES 10K 1/8W 1%	1303312-00	33
2	R82, R83	RES 100 5W 5%	1309094-00	34
2	R30, R31	RES 19.6K 1/8W 1%	1309419-00	35
6	R55, R59, R67, R74 R110, R113	RES 4.64K 1/4W 1%	1309856-00	36

PARTS LIST

QTY	REF DESIGNATION	DESCRIPTION	PART NO.	ITEM
1	L5	CHOKE 1000 MHY	1602723-00	37
2	L2, L4	CHOKE 33 MHY	1601759-00	38
2	L1, L3	CHOKE 120 MHY	1610663-00	39
1	E17	I.C. 7450	1905580-00	40
2	E16, E18	I.C. 7473	1905587-00	41
1	E14	I.C. 7402	1909004-00	42
1	E13	I.C. 7404	1909686-00	43
2	E4, E6	I.C. 7409	1910555-00	44
3	E1, E9, E21	I.C. 1414	1910337-00	45
5	E2, E3, E12, E19, E20	I.C. 75451	1910406-00	46
1	E10	I.C. 74123	1910436-00	47
2	E8, E11	I.C. 72733	1910644-00	48
1	E15	I.C. 74157	1910655-00	49
1	E5	I.C. 7406	1910741-00	50
1	J1	I.C. SOCKET 16 PIN	1211813-02	51
9	Q9 THRU Q15, Q25 Q26	TRANS MXA805	1510705-00	52
6	Q1 - Q5, Q8	TRANS MXA855	1510706-00	53
8	Q17 - Q24	TRANS D44CB	1510421-00	54
86	Z HOLES	STAKED PIN	9009149-00	55
3	J2	CONN 2 POS	1212204-00	56
8	"X" HOLES	SCREW, PAN HD 4/40 X 1/4	9008301-01	57
8	"X" HOLES	NUT, KEP 4/40 X 1/4 X 3/32	9006557-00	58
1	E7	I.C. 75452	1910645-00	59
4	R54, R56, R69, R70	RES 14.7K 1/4W 1%	1302941-00	60

REV. A  
DCS M7727-0-1

REVISIONS		
K	CHANGE NO.	REV

TITLE	READ/WRITE CONTROL	SIZE CODE	D CS	NUMBER	M7727-0-1	REV.	A
SCALE	1/1	SHEET	2	OF	6	DIST.	

THIS DRAWING AND SPECIFICATIONS HEREIN ARE THE PROPERTY OF DIGITAL EQUIPMENT CORPORATION AND SHALL NOT BE REPRODUCED OR COPIED OR USED IN WHOLE OR IN PART AS THE BASIS FOR THE MANUFACTURE OR SALE OF ITEMS WITHOUT WRITTEN PERMISSION. COPYRIGHT © 1974 DIGITAL EQUIPMENT CORPORATION

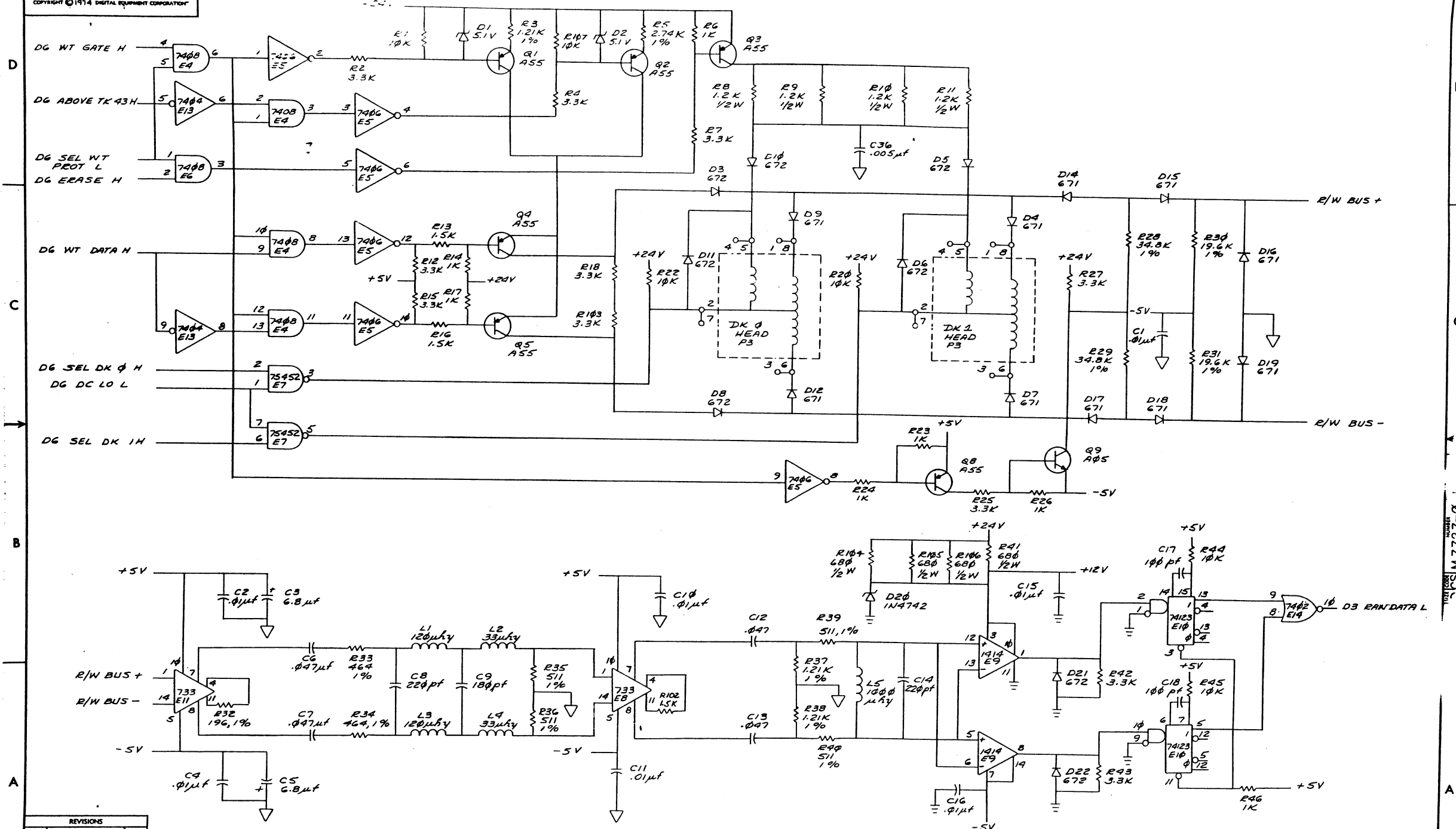

THIS DRAWING AND SPECIFICATIONS HEREIN ARE THE PROPERTY OF DIGITAL EQUIPMENT CORPORATION AND SHALL NOT BE REPRODUCED OR COPIED OR USED IN WHOLE OR IN PART AS THE BASIS FOR THE MANUFACTURE OR SALE OF ITEMS WITHOUT WRITTEN PERMISSION. COPYRIGHT © 1974 DIGITAL EQUIPMENT CORPORATION

note: opto isolators are on drive channels, not pch

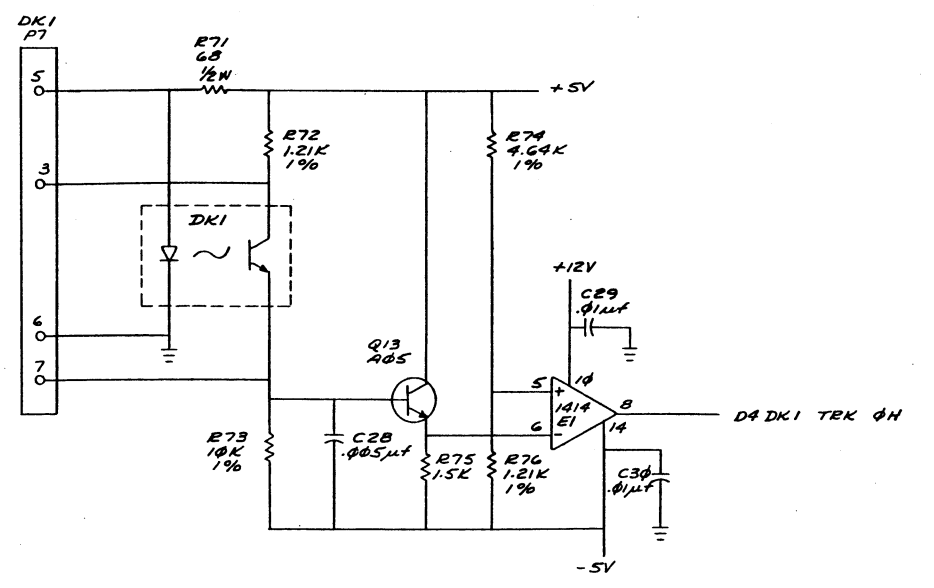
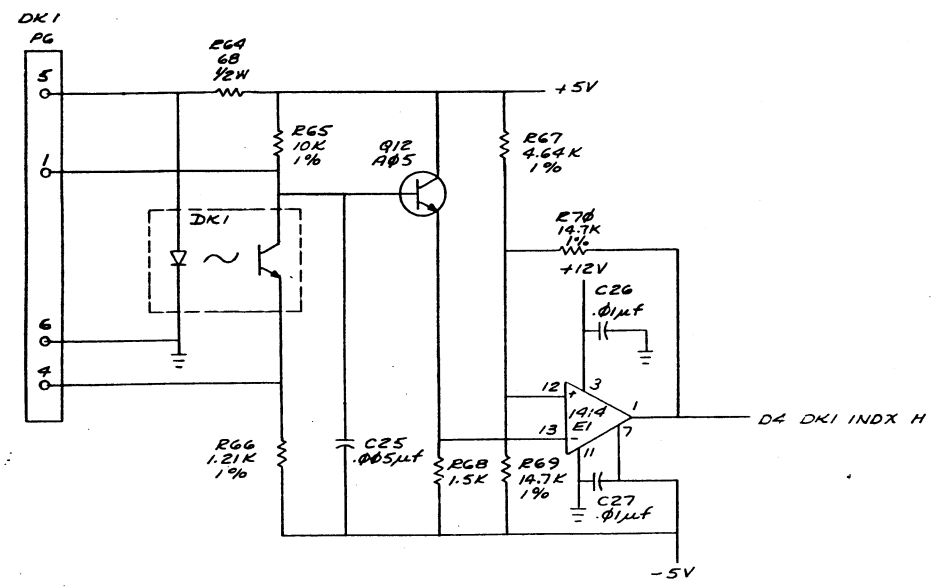
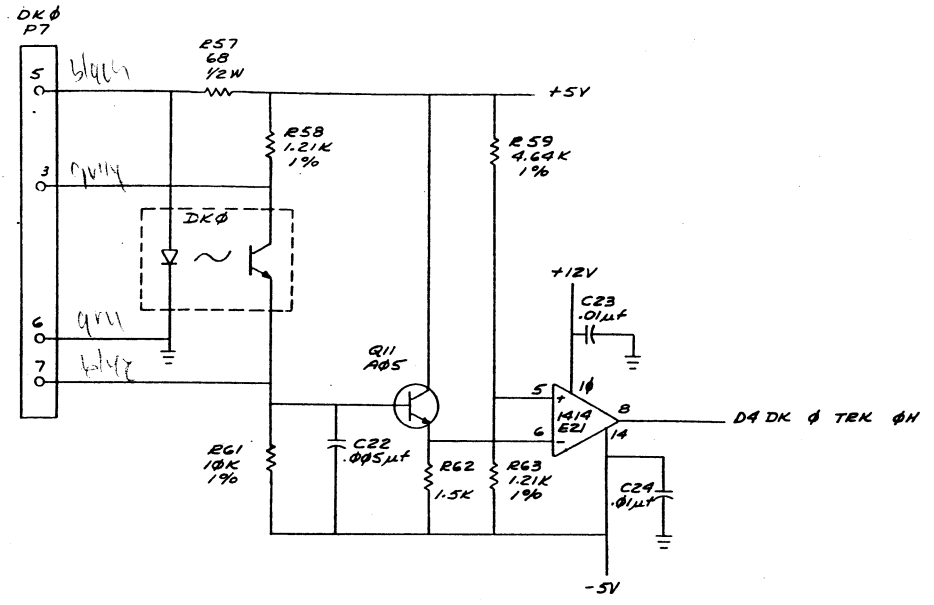
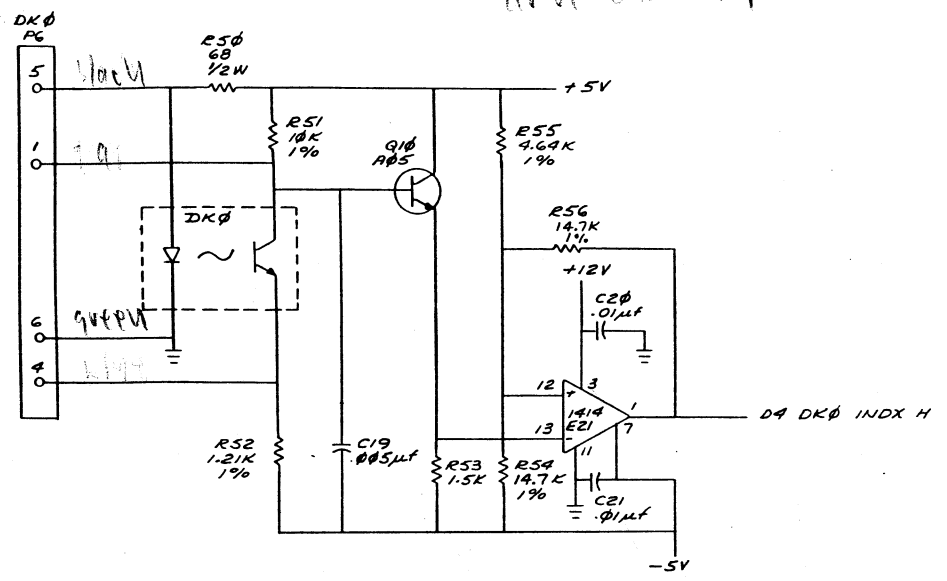

REVISIONS		
CHK	CHANGE NO.	REV.

TITLE	READ / WRITE CONTROL (D4)	SIZE CODE	D	NUMBER	M7727-0-1	REV.	A
SCALE	1/1	SHEET	4	OF	6	DIST.	

DCS M 7727-0-1 A

THIS DRAWING AND SPECIFICATIONS HEREIN ARE THE PROPERTY OF DIGITAL EQUIPMENT CORPORATION AND SHALL NOT BE REPRODUCED OR COPIED OR USED IN WHOLE OR IN PART AS THE BASIS FOR THE MANUFACTURE OR SALE OF ITEMS WITHOUT WRITTEN PERMISSION. COPYRIGHT © 1974 DIGITAL EQUIPMENT CORPORATION

D  
C  
B  
A

D  
C  
B  
A

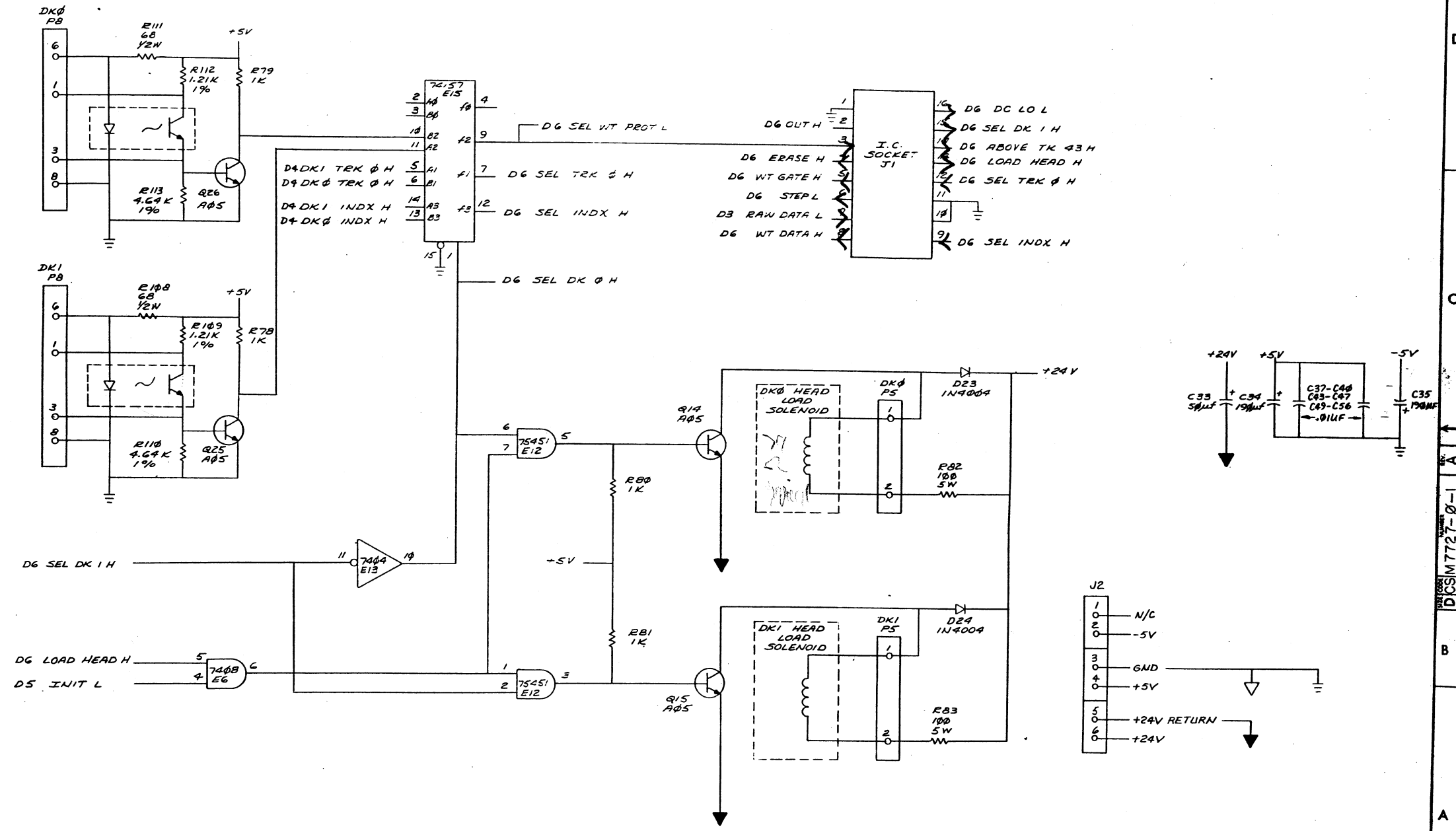

REVISIONS		
CHK	CHANGE NO.	REV.

THIS DRAWING AND SPECIFICATIONS HEREIN ARE THE PROPERTY OF DIGITAL EQUIPMENT CORPORATION AND SHALL NOT BE REPRODUCED OR COPIED OR USED IN WHOLE OR IN PART AS THE BASIS FOR THE MANUFACTURE OR SALE OF ITEMS WITHOUT WRITTEN PERMISSION. COPYRIGHT © 1974 DIGITAL EQUIPMENT CORPORATION

1-7-77 11500 2

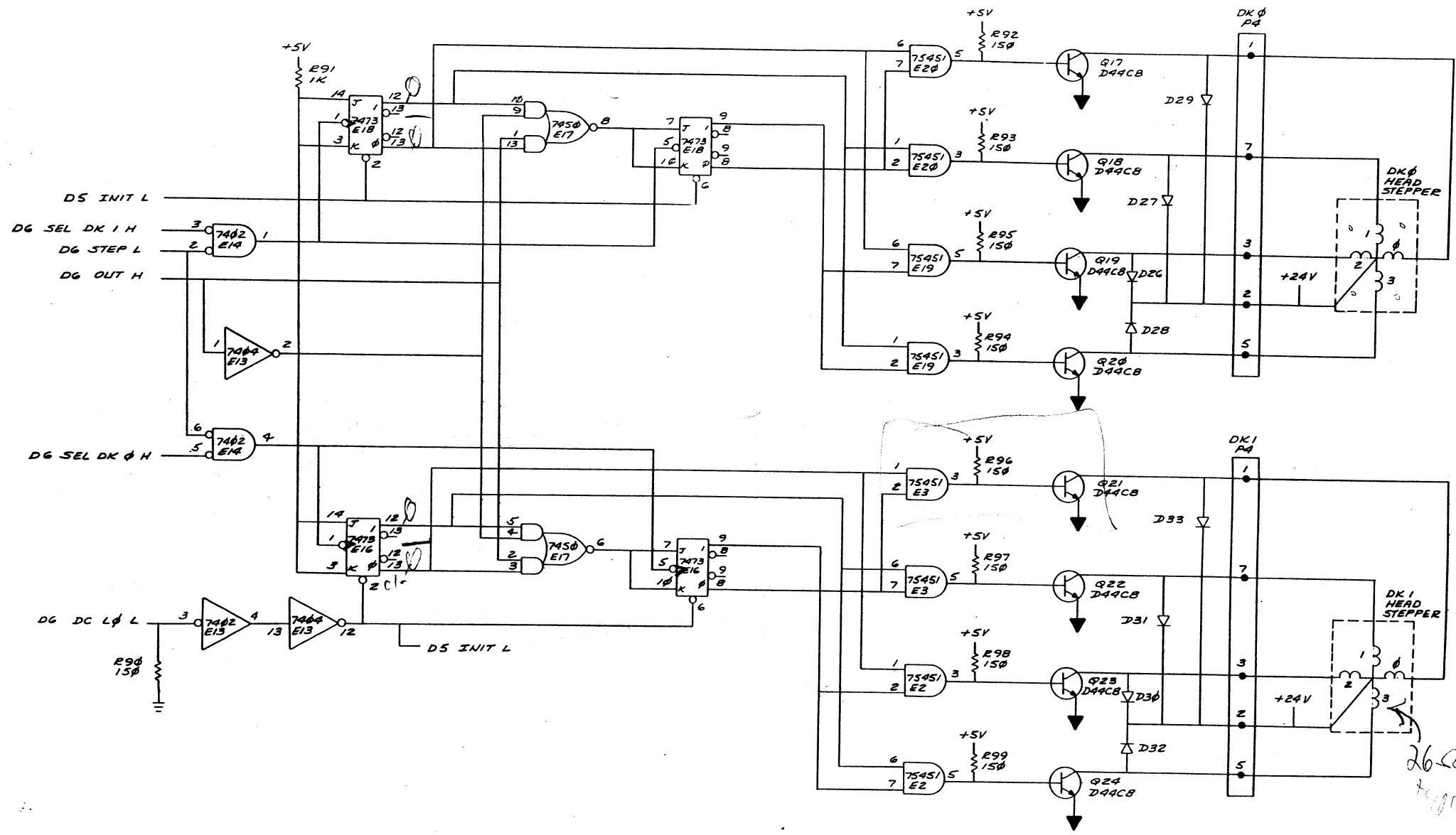

REVISIONS		
CHK	CHANGE NO.	REV.

TITLE READ / WRITE CONTROL (D5) SIZE CODE DCS NUMBER M 7727-0-1 REV. A  
 SCALE SHEET 5 OF 6 DIST.

DCS M 7727-0-1



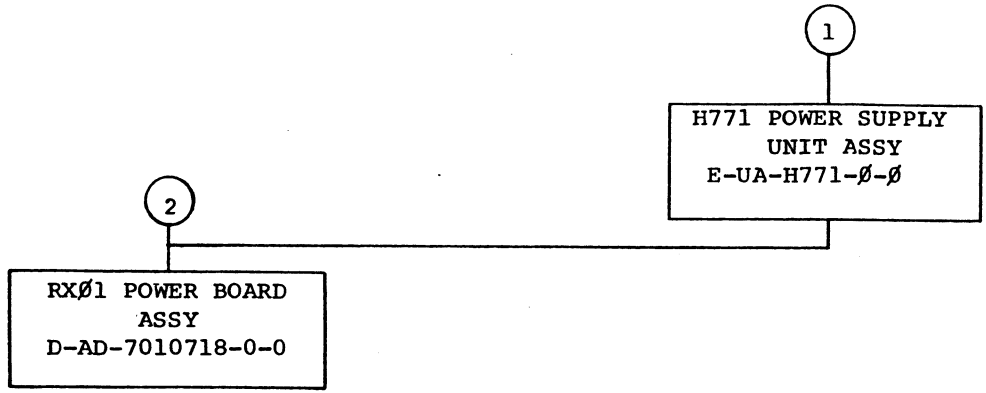

TITLE	SHEET	SIZE	CODE	NUMBER	REV
H771 POWER SUPPLY	2 OF 3	B	DD	H771-Ø	A

CUSTOMER PRINT SET		MECHANICAL					CUSTOMER PRINT SET		ELECTRICAL						
MFG.	SET	FIND NO.	DRAWING NO.	REV	NO OF SHT	DESCRIPTION	OPTION NO./FILE DATE	MFG.	SET	FIND NO.	DRAWING NO.	REV	NO OF SHT	DESCRIPTION	OPTION NO./FILE DATE
		1	E-UA-H771-0-0	A	2	H771 POWER SUPPLY ASSY		X		1	B-DD-H771-0	A	3	H771 POWER SUPPLY	
			E-MD-7412667-0-0		1	CHASSIS, POWER SUPPLY		X			D-CS-H771-A-1	A	1	H771-A CIRCUIT SCHEMATIC	
			D-AD-7010680-0-0		1	TRANSFORMER ASSY, 60 HZ		X			D-CS-H771-C-1	*	1	H771-C CIRCUIT SCHEMATIC	
			D-AD-7010704-0-0		1	TRANSFORMER ASSY, 50 HZ		X			D-CS-H771-D-1	*	1	H771-D CIRCUIT SCHEMATIC	
			C-AD-7010697-0-0		1	POWER CORD ASSY					A-SP-H771-0-1			ENGINEERING SPECIFICATION	
			C-AD-7010972-0-0		1	JUMPER									
			C-MD-7413344-0-0		1	BRACKET, FUSE MOUNTING									
			A-DC-7413403-0-0		1	DECAL, H771-A									
			A-DC-7414250-0-0		1	DECAL, H771-C									
			A-DC-7414251-0-0		1	DECAL, H771-D									
		2	D-AD-7010718-0-0		1	RX01 POWER BOARD ASSY									
			D-IA-7010854-0-0		1	READ/WRITE BOARD HARNESS		X		2	D-AD-7010718-0-0	*	1	RX01 POWER BOARD ASSY	
			D-IA-7010853-0-0		1	DISK CONTROL BOARD HARNESS		X			D-CS-5411398-0-1	*	1	RX01 POWER BOARD ASSY	

CUSTOMER PRINT SET CODES  
X = PRINT OF DOCUMENT INCLUDED IN PRINT SET  
C = INCLUDES ALL PRINTS INDICATED ON DOCUMENT  
S = CONFIDENTIAL AUTHORIZED SIGNATURE REQUIRED

TITLE: H771 POWER SUPPLY  
SHEET 3 OF 3  
SIZE CODE: B DD  
NUMBER: H771-0  
REV: A

THIS DRAWING AND SPECIFICATIONS HEREIN ARE THE PROPERTY OF DIGITAL EQUIPMENT CORPORATION AND SHALL NOT BE REPRODUCED OR COPIED OR USED IN WHOLE OR IN PART AS THE BASIS FOR THE MANUFACTURE OR SALE OF ITEMS WITHOUT WRITTEN PERMISSION. COPYRIGHT © 1975, DIGITAL EQUIPMENT CORPORATION

1-7-1224 2

- NOTES:
1. ALL WIRE TO BE #18 AWG UNLESS OTHERWISE SPECIFIED.
  2. SLOT BETWEEN P1-4 + P1-5 CONTAINS A DUMMY PIN. SLOT BETWEEN P2-4 + P2-5 ALSO CONTAINS A DUMMY PIN.
  3. NO DOUBLE CRIMPS ARE ALLOWED IN MOLEX CONNECTOR(S) TO MOTOR(S).

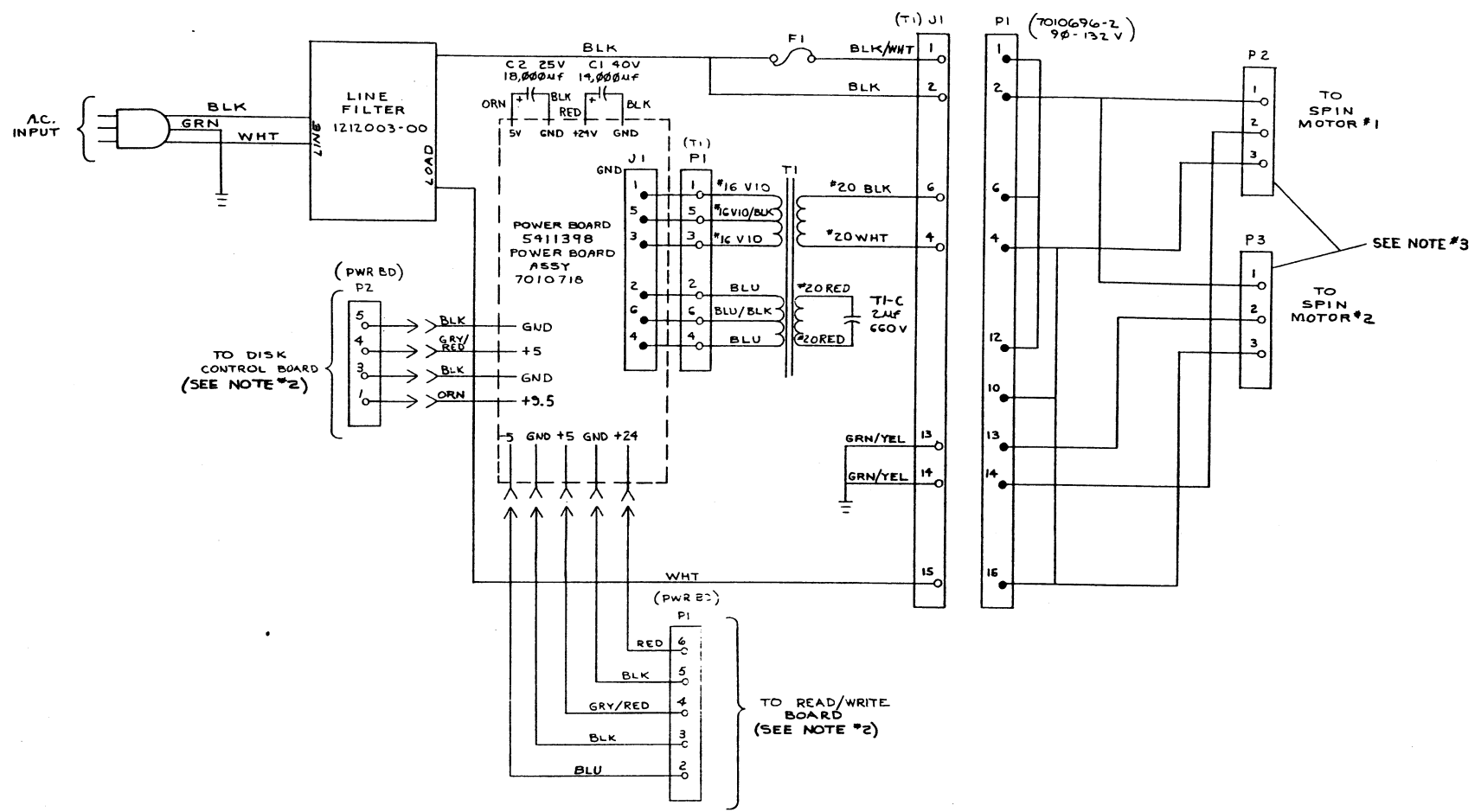

REV.	DATE	BY	CHK'D
1	1/22/75	D.E. O'Leary	D.E. O'Leary
2	3/18/75	B. HAZEN	B. HAZEN

DRN. D.E. O'Leary 1/22/75	FIRST USED ON	Rx01	Digital
CHK'D D.E. O'Leary 3/18/75	TITLE	H771-A POWER CONNECTIONS	
ENG. D.E. O'Leary 1-18-75	PROJ. ENG. B. HAZEN 3-18-75	SCALE	NONE
PROD. B. HAZEN 3/18/75	NEXT HIGHER ASSY.	B-DD-H771-0	SIZE CODE
		SCALE	NONE
		SHEET	1 OF 1

THE DESIGN AND SPECIFICATIONS HEREIN ARE THE PROPERTY OF DIGITAL EQUIPMENT CORPORATION AND SHALL NOT BE REPRODUCED OR COPIED IN WHOLE OR IN PART AS THE BASIS FOR THE MANUFACTURE OR SALE OF ITEMS UNLESS SO WRITTEN HEREON. DIGITAL EQUIPMENT CORPORATION © 1975, DIGITAL EQUIPMENT CORPORATION

- NOTES:
1. SLOT BETWEEN PI-4 AND PI-5 CONTAINS A DUMMY PIN. SLOT BETWEEN P2-4 AND P2-5 ALSO CONTAINS A DUMMY PIN.
  2. NO DOUBLE CRIMPS ALLOWED IN MOLEX CONNECTOR(S) TO MOTOR(S).
  3. ALL WIRES TO BE #18 AWG UNLESS OTHERWISE SPECIFIED.

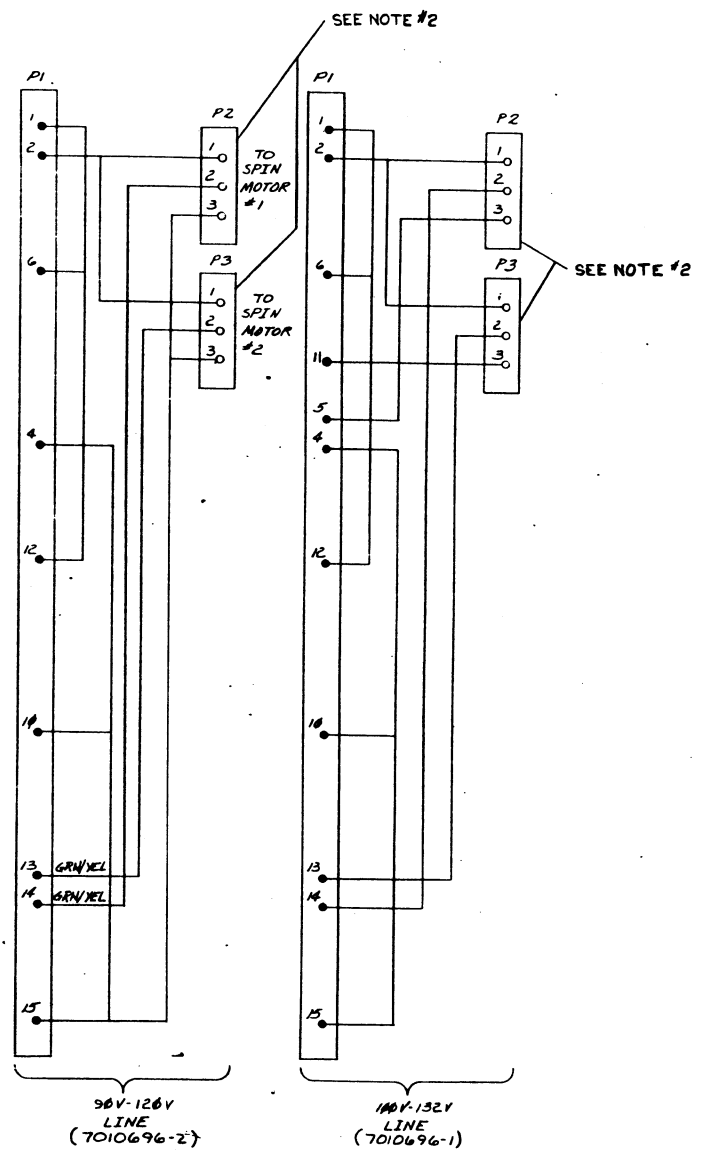
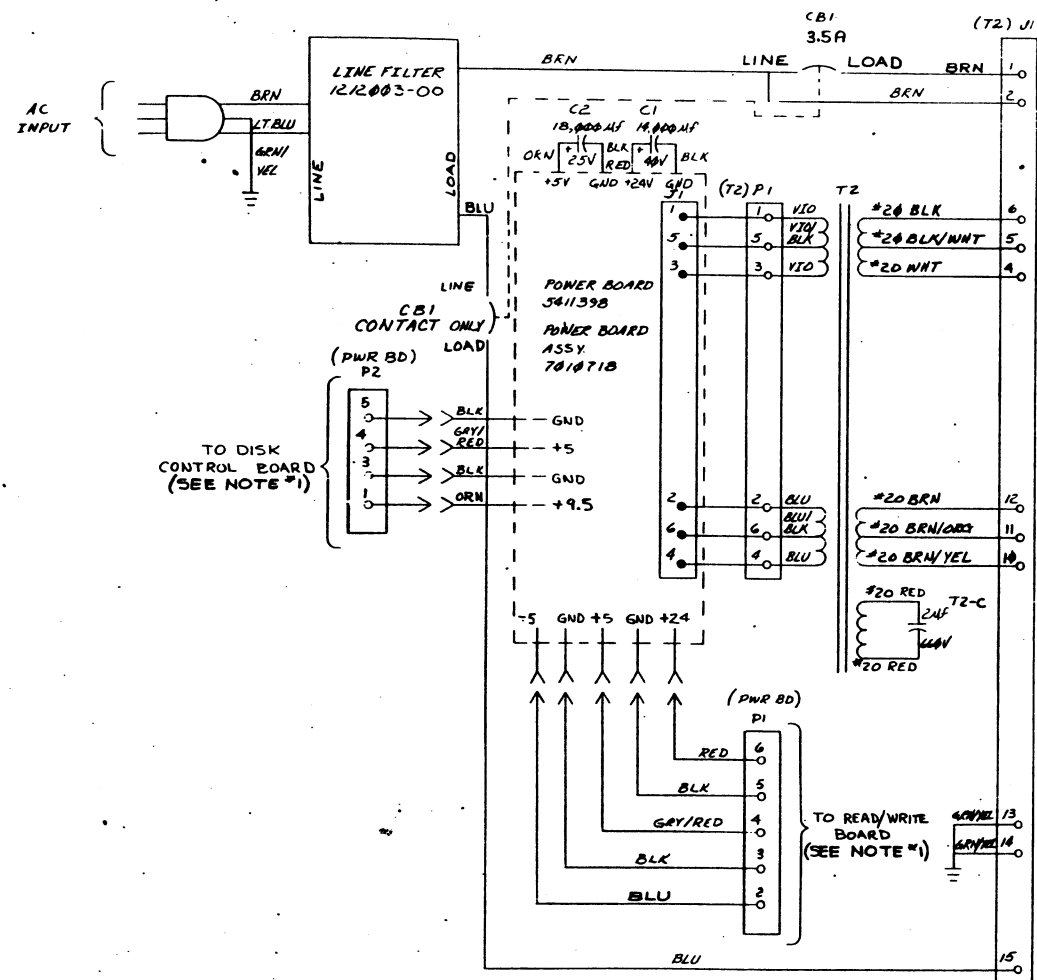

REV.	DATE	BY
1	7-30-75	E. REMOND
2	8-5-75	E. REMOND
3	8-12-75	E. REMOND
4	8-12-75	E. REMOND
5	8-12-75	E. REMOND

DRN. 2/10/75	7-30-75	FILED IN	RX01
CHK. E. REMOND	8-5-75	TITLE	H771-C POWER CONNECTIONS
ENGR. J. L. BROWN	8-12-75	SCALE	D CS H771-C
PROD. E. REMOND	8-12-75	SHEET	1 OF 1
NEXT HIGHER ASSY.		DIST.	

CS H771-B-1



THIS DRAWING AND SPECIFICATIONS HEREIN ARE THE PROPERTY OF DIGITAL EQUIPMENT CORPORATION AND SHALL NOT BE REPRODUCED OR COPIED OR USED IN WHOLE OR IN PART AS THE BASIS FOR THE MANUFACTURE OR SALE OF ITEMS WITHOUT WRITTEN PERMISSION. COPYRIGHT © 1975, DIGITAL EQUIPMENT CORPORATION

ITEM NO.	DESCRIPTION	FROM		TO		LENGTH	
		AWG	COLOR	CONN	TERM		CONN
1	18	BLU	P1 POINT 1	---	PWR # 11	SOLDER	---
	↑	BLK	P1 POINT 2	---	PWR # 6	---	---
	↓	GRY/RED	P1 POINT 3	---	PWR # 9	---	---
	↓	BLK	P1 POINT 4	---	PWR # 5	---	---
2	↓	RED	P1 POINT 5	---	PWR # 12	---	---
	↓	ORN	P2 POINT 1	---	PWR # 4	---	---
	↓	BLK	P2 POINT 2	---	PWR # 7	---	---
	↓	GRY/RED	P2 POINT 3	---	PWR # 10	---	---
3	14	RED	P3	ITEM 7	PWR # 13	---	13 IN ±.25
4	14	BLK	P5	ITEM 7	PWR # 2	---	7 IN ±.25
5	14	ORN	P4	ITEM 7	PWR # 1	---	11 IN ±.25
4	14	BLK	P6	ITEM 7	PWR # 3	SOLDER	9 IN ±.25

- NOTES:
1. STRIP LENGTH FOR ITEMS 3, 4 & 5 ARE TO BE .16 LONG.
  2. THE BLACK WIRES ON P1 & P2 CAN BE INTERCHANGED BETWEEN POINTS 5, 6, 7, & 8 ON THE POWER BOARD.
  3. INK STAMP ASS'Y NO. 7010718 IN FIGURES, 13 HIGH WHERE SHOWN.

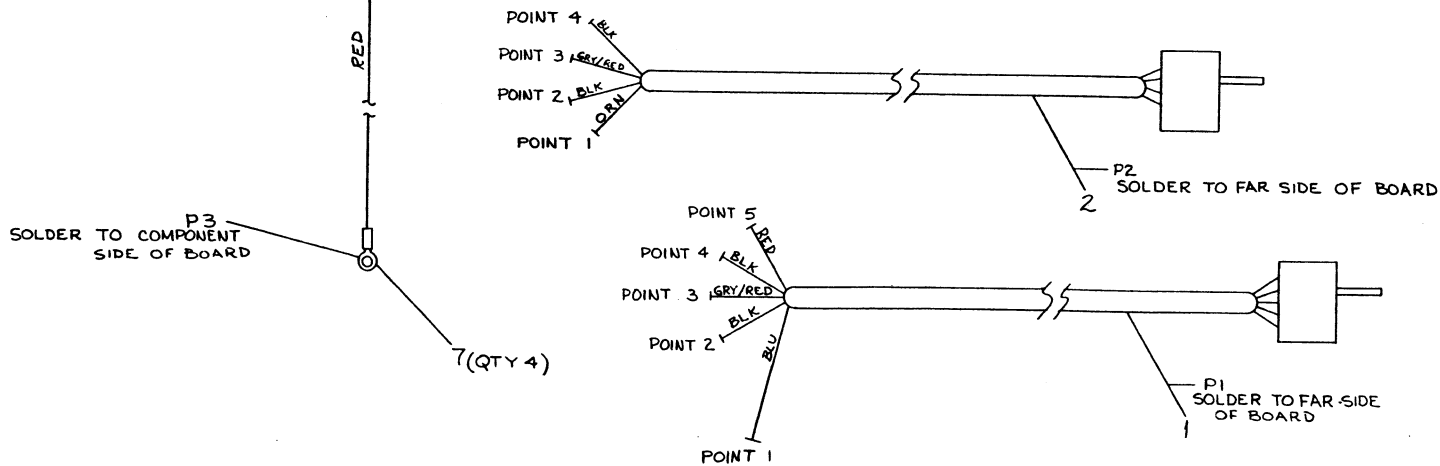
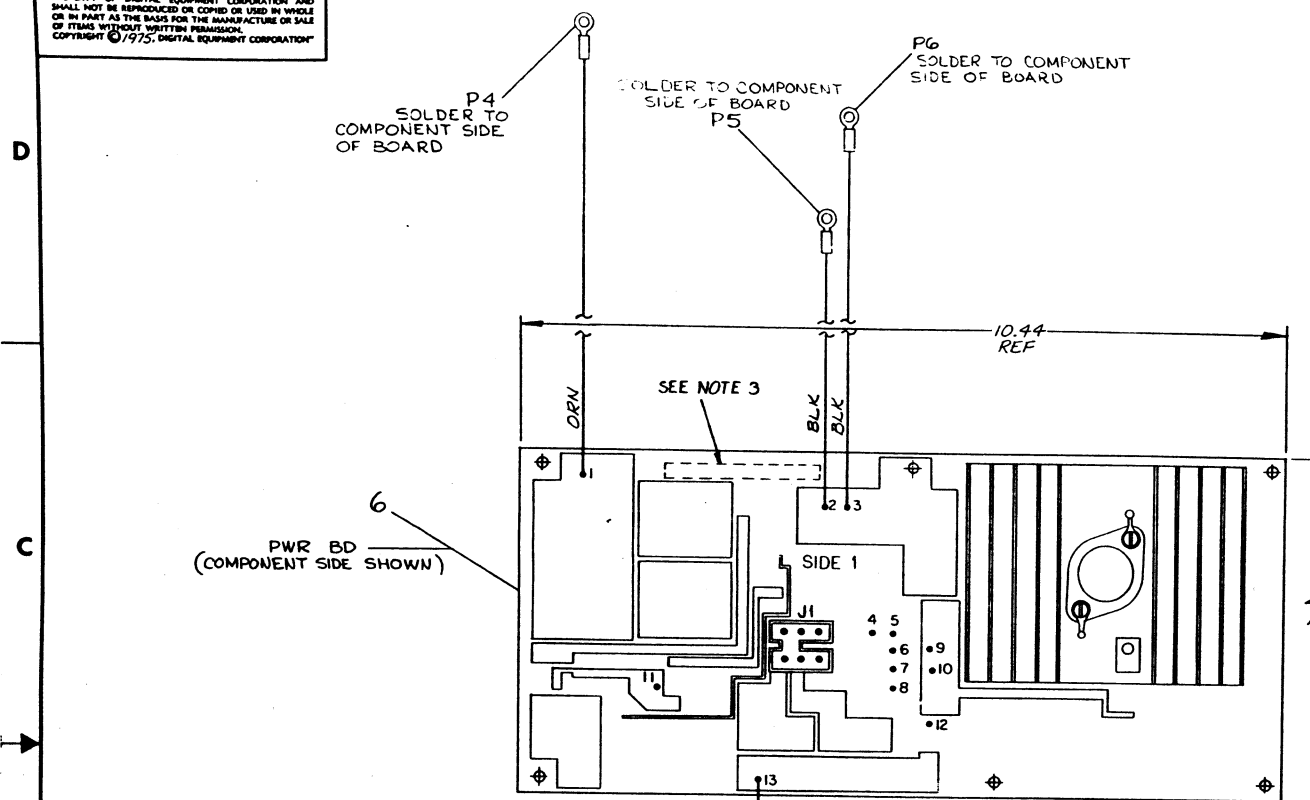

DESCRIPTION	DWG. PART NO.	ITEM NO.
4 CONN. SOLDERLESS	9007928-00	7
1 POWER SUPPLY BOARD, RXØ1	D-05-541139B-0-1	6
1/4 WIRE, #14 AWG, IPVC, ORANGE	9107370-33	E
1/4 WIRE, #14 AWG, IPVC, BLACK	9107370-00	E
1/4 WIRE, #14 AWG, IPVC, RED	9107370-22	E
1 HARNESS, DISK CONTROL BOARD	D-1A-7010853-0-0	1
1 HARNESS, READ/WRITE BOARD	D-1A-7010854-0-0	1

DESCRIPTION		DNG. PART NO.		ITEM NO.	
UNLESS OTHERWISE SPECIFIED DIMENSIONS ARE IN INCHES					
ANGLES	±.01	±.02	±.03	±.04	±.05
SURFACE QUALITY	1.0	2.0	3.0	4.0	5.0
QUANTITY & VARIATION	1.000	1.010	1.020	1.030	1.040

THIRD ANGLE PROJECTION

REMOVE BURRS AND BREAK SHARP CORNERS

DO NOT SCALE DWG

MATERIAL SEE PARTS LIST

FINISH

DRN. T. Quinn 1/28/75

CHK'D M. C. 1/28/75

ENG. B. W. 1/28/75

PROJ. ENG. 1/28/75

PROD. 1/28/75

FIRST USED ON H771

TITLE RXØ1 POWER BOARD ASS'Y

SIZE CODE D AD

NUMBER 7010718-0-0

REV. B

SHEET 1 OF 1

REV.	DATE	BY	CHK'D
A	1-28-75	C. YOUSE	
B	2-20-75	B. HAZEN	
C	3-12-75		

7010718-0-1



"THE DIMENSIONS AND SPECIFICATIONS SHOWN ARE THE PROPERTY OF DIGITAL EQUIPMENT CORPORATION AND SHALL NOT BE REPRODUCED OR COPIED IN WHOLE OR IN PART AS THE BASIS FOR THE MANUFACTURE OR SALE OF OTHER EQUIPMENT WITHOUT PERMISSION OF DIGITAL EQUIPMENT CORPORATION."

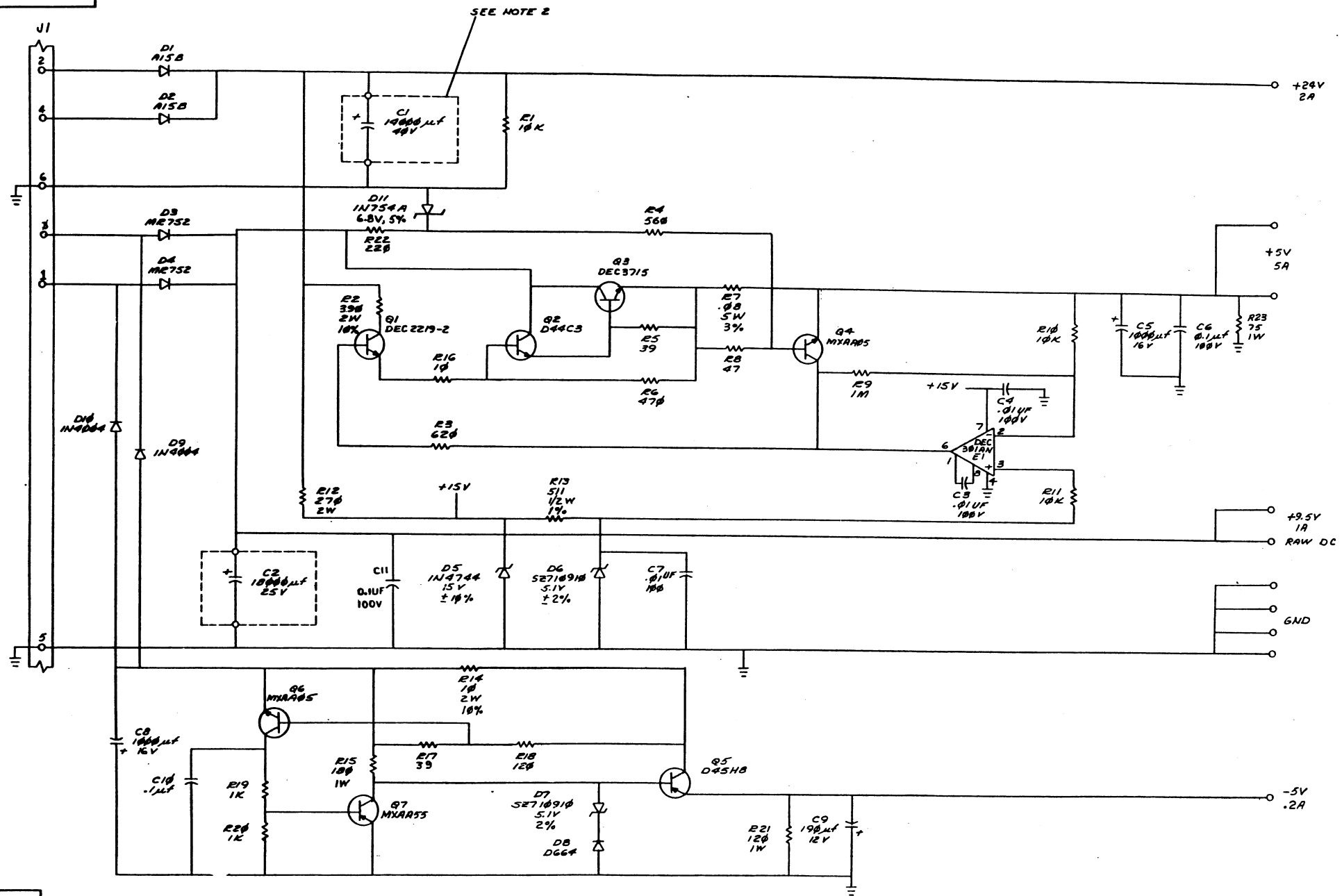

REVISIONS		
CHK	CHANGE NO.	REV.