

33 TYPING UNIT
DISASSEMBLY AND REASSEMBLY

CONTENTS	PAGE	1. GENERAL
1. GENERAL	1	1.01 This section provides disassembly and reassembly information for the 33 typing unit. It is reissued to include instructions concerning the downstop bracket for the form-out mechanism on sprocket feed units. Marginal arrows indicate additions and changes.
2. DISASSEMBLY AND REASSEMBLY . .	2	
RIBBON MECHANISM	2	
CARRIAGE MECHANISM	2	1.02 References to left, right, front, rear, etc, consider the typing unit to be viewed from a position where the ribbon mechanism faces up and the selector mechanism is located to the viewer's left.
CARRIAGE DRIVE BAIL	3	
CODEBAR MECHANISM	4	
CODEBAR RESET BAIL	4	1.03 The disassembly procedure given in this section divides the typing unit into its major assemblies and mechanisms. If further disassembly is required, refer to the appropriate illustrated parts section which shows detailed arrangements of parts. Where it will help in determining location, the numbers of the parts are given in the instructions.
SPACING PAWL MECHANISM	4	
FUNCTION LEVER MECHANISM	5	
SPACING DRUM MECHANISM	5	
DISTRIBUTOR TRIP SHAFT MECHANISM	5	CAUTION: BEFORE BEGINNING DISASSEMBLY, REMOVE CONNECTORS FROM EXTERNAL RECEPTACLES (POWER SOURCE, DATA SET, ETC).
DISTRIBUTOR MECHANISM	6	
FUNCTION ROCKER SHAFT MECHANISM	7	1.04 Most of the mechanisms are mounted on castings by self-tapping screws. Therefore, to remove the mechanisms, do not remove the screws, merely loosen them unless specifically instructed otherwise.
FUNCTION BOX MECHANISM	7	
PLATEN MECHANISM	7	
A. Friction Feed	7	1.05 Retaining rings are made of spring steel and have a tendency to release suddenly. To avoid loss of these rings when removing them, proceed as follows.
B. Sprocket Feed	7	
FORM-OUT MECHANISM	7	(a) Hold retaining ring to prevent it from rotating.
TRIP SHAFT MECHANISM	9	(b) Place blade of screwdriver in one of the ring's slots and rotate screwdriver to increase diameter.
SELECTOR MECHANISM	9	(c) Ring will come off easily in fingers without flying.
MAIN SHAFT MECHANISM	10	
MOTOR	11	

1.06 All tools used to remove the mechanisms referred to in this section can be found in the 570-005-800TC standard tool section.

1.07 All damaged, worn, or distorted parts should be replaced if encountered in the disassembly and reassembly procedures.

2. DISASSEMBLY AND REASSEMBLY

Note: For information concerning the proper procedure to remove the typing unit from the set, refer to Section 574-100-702TC.

RIBBON MECHANISM

2.01 To remove ribbon mechanism (Figure 1), proceed as follows.

(a) Remove ribbon by removing the two ribbon spools and disengaging the ribbon from the ribbon guide and the TP183324 reverse arm.

(b) Loosen the two TP152893 mounting screws and lift ribbon mechanism from carriage.

(c) To replace ribbon mechanism, reverse procedure used to remove it.

CARRIAGE MECHANISM

2.02 To remove carriage mechanism (Figure 1), proceed as follows.

(a) Unhook carriage return spring from carriage.

(b) Loosen the two TP180798 mounting screws in spacing pulley mounting bracket. Rotate and remove bracket.

(c) Loosen the two TP180798 mounting screws in spacing drum mounting bracket. Remove mounting bracket.

(d) Disengage spacing belt from pulley on spacing drum.

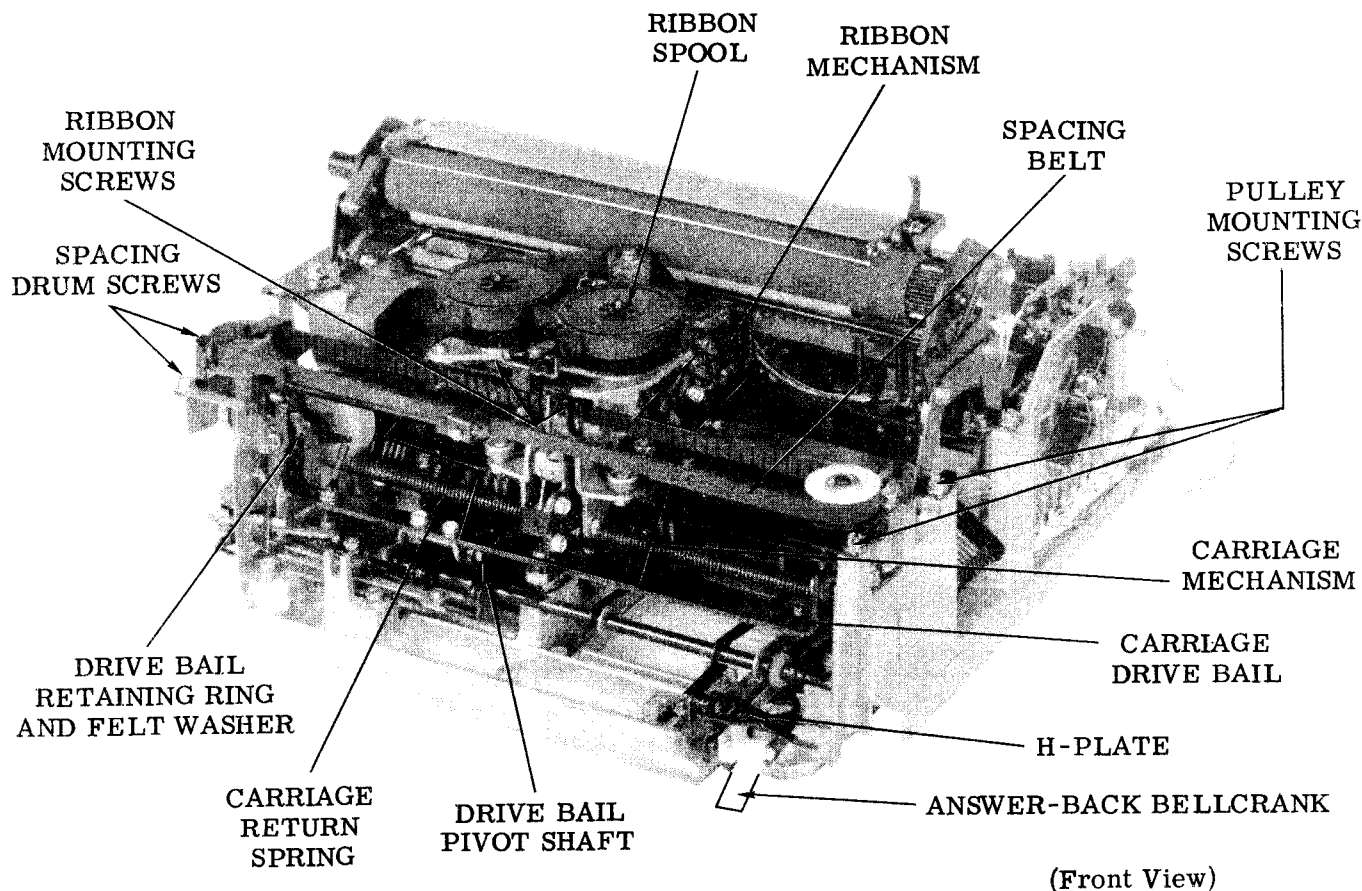

Figure 1 - Typing Unit

- (e) Remove front carriage shaft by sliding it to the right.
- (f) To disengage the rollers from the drive bail, slightly lift the front of the carriage. Rotate the carriage to the left and disengage the slide guides from the codebars.
- (g) Lift the carriage from the unit.
- (h) To replace the carriage mechanism, reverse the procedure used to remove it and observe the following precautions.

- (1) Make sure nylon slide guides engage proper associated codebars.
- (2) Make sure two rear rollers engage carriage rear plate.

CARRIAGE DRIVE BAIL

2.03 To remove carriage drive bail (Figures 1 and 2), proceed as follows.

- (a) Remove the carriage mechanism (2.02).

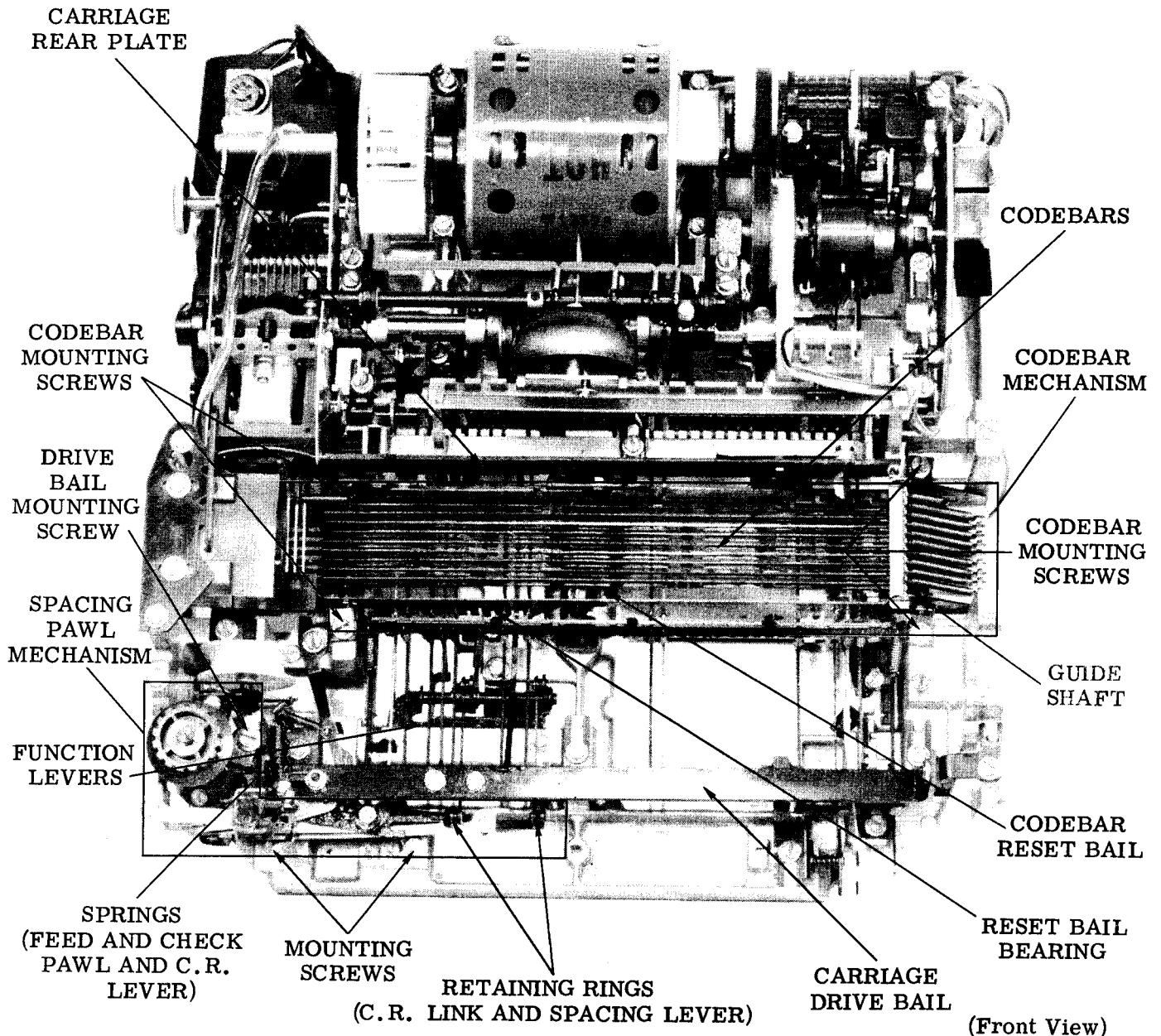

Figure 2 - Typing Unit (Carriage and Platen Removed)

- (b) Remove the TP3598 nut from the TP180546 post.
- (c) Loosen the TP180798 mounting screw and remove the TP181230 clamp plate at left end of carriage drive bail.
- (d) Remove the TP119651 retaining ring and felt washer at right end of bail.
- (e) Remove drive bail by sliding it to left.
- (f) To replace drive bail assembly, reverse procedure used to remove it.

CODEBAR MECHANISM

2.04 To remove codebar mechanism (Figure 4), proceed as follows.

- (a) Remove the carriage mechanism (2.02).
- (b) Loosen the TP180798 mounting screw and remove the TP180682 upstop bracket. Tighten the TP180798 mounting screw to secure the TP181230 retaining plate to the base casting.
- (c) Remove the TP180788 carriage rear rail.
- (d) Remove the TP180959 bracket.
- (e) Rotate the main shaft so that the TP180751 lever is positioned on the low part of the codebar cam.
- (f) Loosen the four TP180798 mounting screws and remove the four TP180925 clamps.
- (g) Lift the blocking levers from the guide slots and lift the codebar mechanism from the frame.
- (h) To replace codebar mechanism, reverse procedure used to remove it and observe the following precautions.
 - (1) Make sure function levers are in proper slots in codebars.
 - (2) Make sure codebars reset extensions are to right of TP180928 codebar reset bail and in proper slots of guide.
 - (3) Make sure both right and left TP180920 guide shafts are fully seated in their mountings.

(4) Make sure the TP181070 space suppression lever is to the left of the TP180947 print suppression codebar.

(5) Make sure the TP180752 print suppression latch lever fits into slot of the TP180923 bracket mounted on the rear tie bracket.

(6) Make sure that the left ends of the codebars fully engage their respective blocking lever tines.

CODEBAR RESET BAIL

2.05 To remove codebar reset bail (Figures 2 and 3), proceed as follows.

- (a) Remove the codebar spring.
- (b) Remove the TP125252 spring from the TP180773 plate.
- (c) From underside of base casting remove the two TP181245 screws from the two TP180930 bearings.
- (d) Lift the TP180928 codebar reset bail from base casting.
- (e) To replace codebar reset bail, reverse the procedure used to remove it. When replacing the TP181245 screws, make sure that one of them passes through the TP180776 spring bracket before it enters the bearing.

SPACING PAWL MECHANISM

2.06 To remove spacing pawl mechanism (Figure 2), proceed as follows.

- (a) Unhook the TP74701 spring from the TP181067 feed pawl, the TP70466 spring from the TP181065 check pawl, and the TP70388 spring from the TP181319 carriage return lever.
- (b) Remove the TP119649 retaining rings from the TP181314 carriage return link and the TP181068 spacing lever.
- (c) Remove carriage mechanism (2.02).
- (d) Remove spacing drum mechanism (2.08).
- (e) Loosen the two TP180798 mounting screws.

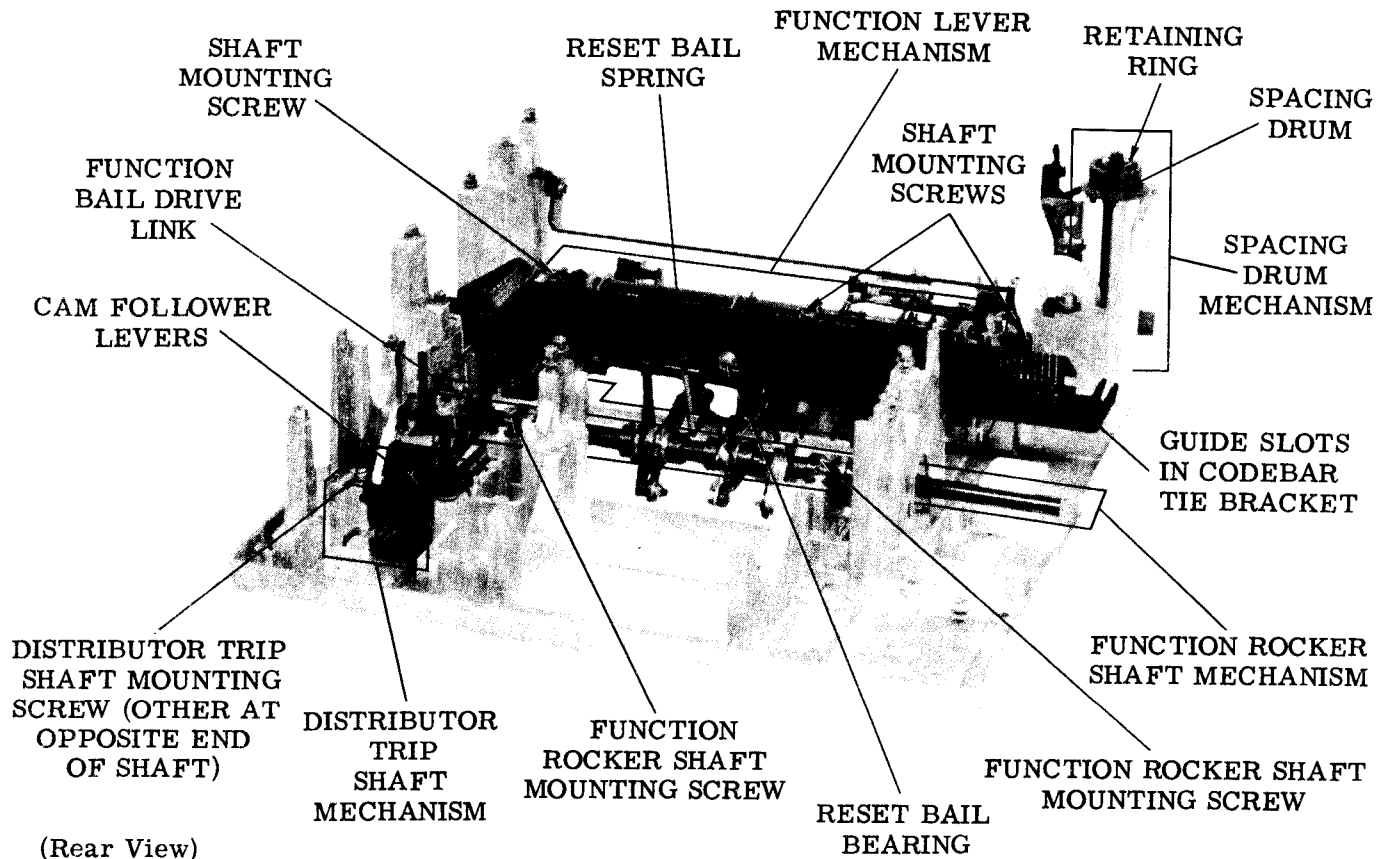

Figure 3 - Typing Unit (A Number of Mechanisms Removed)

- (f) Lift spacing pawl mechanism from base casting.
- (g) To replace spacing pawl mechanism, reverse the procedure used to remove it.

FUNCTION LEVER MECHANISM

- 2.07 To remove function lever mechanism (Figure 3), proceed as follows.
- (a) Loosen the three TP180798 mounting screws and rotate levers pivot shaft so flat side is vertical.
 - (b) To remove any function lever, unhook its spring and disengage lever from pivot shaft.
 - (c) To remove levers pivot shaft, remove the two TP180797 clamp plates and the TP180795 spring bracket. Lift out shaft with two drive links attached.
 - (d) To replace function lever mechanism, reverse the procedure used to remove it.

SPACING DRUM MECHANISM

- 2.08 To remove spacing drum mechanism (Figure 3), proceed as follows.
- (a) Remove the carriage mechanism (2.02).
 - (b) Remove the TP119653 retaining ring from top of spacing drum and remove drum.
 - (c) From underside of base casting, remove the TP112626 nut and lockwasher from lower end of spacing drum shaft.
 - (d) Lift spacing drum shaft from base casting.
 - (e) To replace spacing drum mechanism, reverse procedure used to remove it.

DISTRIBUTOR TRIP SHAFT MECHANISM

- 2.09 To remove distributor trip shaft mechanism (Figure 3), proceed as follows.

- (a) Remove the distributor mechanism (2.10).
- (b) Remove the TP119649 retaining ring from post connecting links to each of following cam follower levers: TP180985, TP180820, and TP180821.
- (c) Unhook five springs from the TP180988 spring bracket.
- (d) Loosen the TP180798 screw and TP182264 post, and remove the two TP180972 buffer clamps.
- (e) Remove distributor trip shaft mechanism from base casting.
- (f) To replace distributor trip shaft mechanism, reverse procedure used to remove it.

DISTRIBUTOR MECHANISM

- 2.10 To remove distributor mechanism (Figure 4), proceed as follows.
- (a) Remove the TP181242 screw and TP180980 brush holder.
 - (b) Loosen the three TP180989 distributor disc mounting screws.
 - (c) Remove the TP180798 mounting screw and the TP180850 bracket and then remove the clutch trip mechanism.
 - (d) Loosen the TP180798 screw and remove the TP180998 clamp.
 - (e) Loosen the TP156740 screw and remove the TP182263 bracket.
 - (f) Loosen the two screws that mount the TP181023 right bracket.

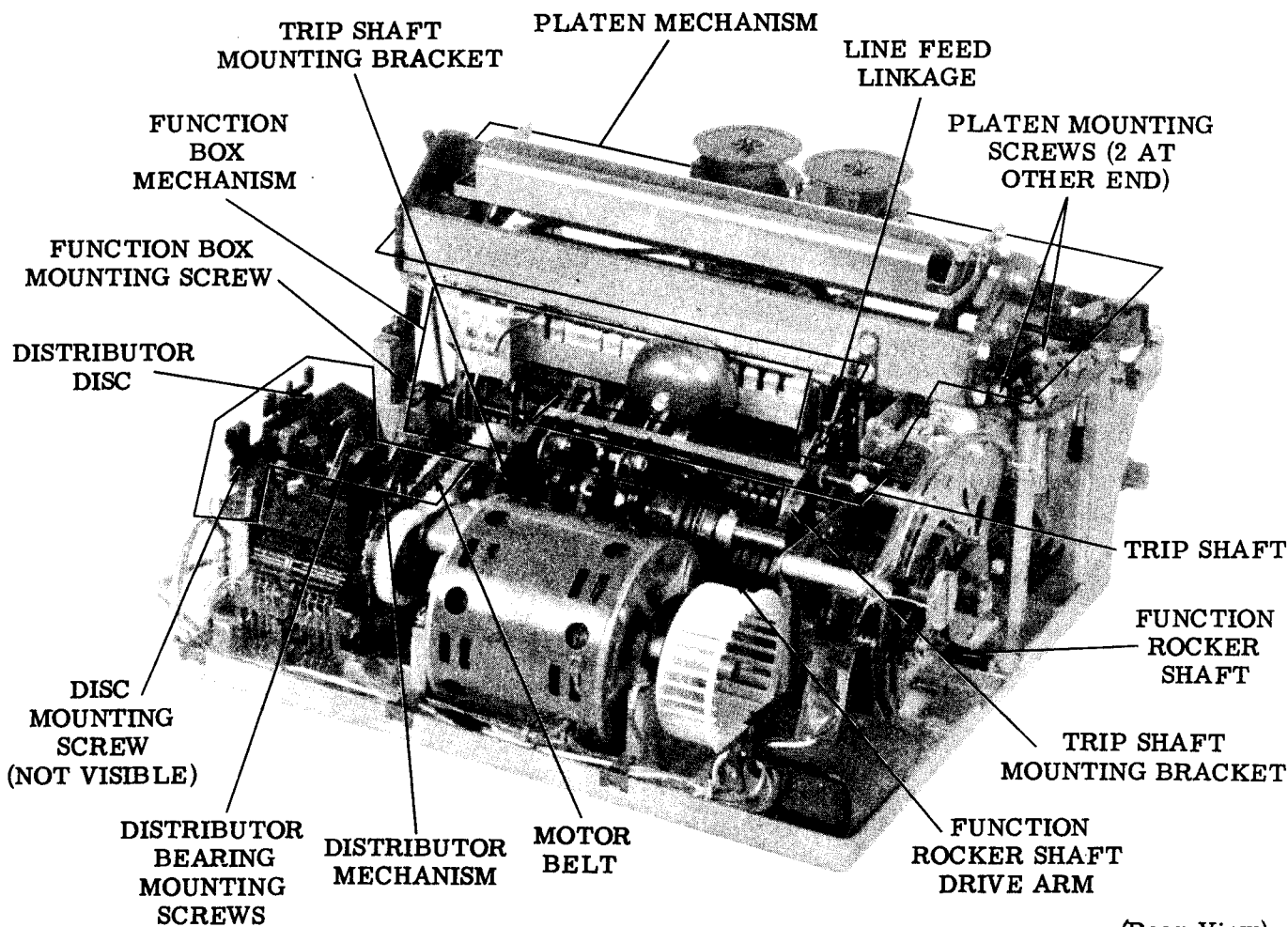

(Rear View)

Figure 4 - Typing Unit

- (g) Remove the belt from the motor.
- (h) Lift the distributor mechanism from the base.
- (i) To replace distributor mechanism, reverse procedure used to remove it. Make sure leads are inserted into proper connections on disc. (See the appropriate wiring diagram.)

FUNCTION ROCKER SHAFT MECHANISM

- 2.11 To remove function rocker shaft mechanism (Figure 3), proceed as follows.
 - (a) Remove the trip shaft mechanism (2.16).
 - (b) Remove the form-out mechanism (2.15).
 - (c) Remove the main shaft mechanism (2.18).
 - (d) Remove the TP119651 retaining rings from posts at rear of the TP180769 left and TP180770 right function bail drive link.
 - (e) Loosen the two TP180798 mounting screws and remove the left and right function rocker shaft bearing clamp plates.
 - (f) Lift the function rocker shaft mechanism from the base casting.
 - (g) To replace the function rocker shaft mechanism, reverse the procedure used to remove it.

FUNCTION BOX MECHANISM

- 2.12 To remove function box mechanism (Figures 2, 4, and 7), proceed as follows.
 - (a) Remove the carriage mechanism (2.02).
 - (b) Remove the platen mechanism (2.13).
 - (c) Unhook the TP125252 spring (connects to TP180928 codebar reset bail) from the TP180773 plate.
 - (d) Loosen the two TP180798 mounting screws and remove the two TP180796 clamp plates.
 - (e) Lift function box mechanism from base casting.

- (f) To replace function box mechanism, reverse procedure used to remove it. Make sure function levers are in their proper slots and aligned with their respective pawls.

PLATEN MECHANISM

A. Friction Feed

- 2.13 To remove platen mechanism (Figure 4), proceed as follows.
 - (a) Remove the TP119651 retaining ring and the TP90615 spring from line feed linkage.
 - (b) Disengage the TP181176 link from the TP181168 bellcrank.
 - (c) Loosen the four TP181242 mounting screws in the two platen side plates.
 - (d) Lift platen mechanism from typing unit.
 - (e) To replace platen mechanism, reverse procedure used to follow it.

B. Sprocket Feed

- 2.14 To remove platen mechanism (Figures 4 and 5), proceed as follows.
 - (a) Loosen the TP3598 nut on the TP183351 idler post. Back off the two TP183341 idlers and slip the two TP183379 belts off the sprockets.
 - (b) Loosen the four TP181242 mounting screws in the two platen side plates.
 - (c) Lift platen mechanism from typing unit.
 - (d) To replace platen mechanism, reverse the procedure used to remove it.

FORM-OUT MECHANISM

- 2.15 To remove form-out mechanism (Figures 4 and 5), proceed as follows.
 - (a) With the typing unit removed from sub-base, remove the TP181242 mounting screw which secures the TP180980 brush holder.
 - (b) Remove brush holder and brush.

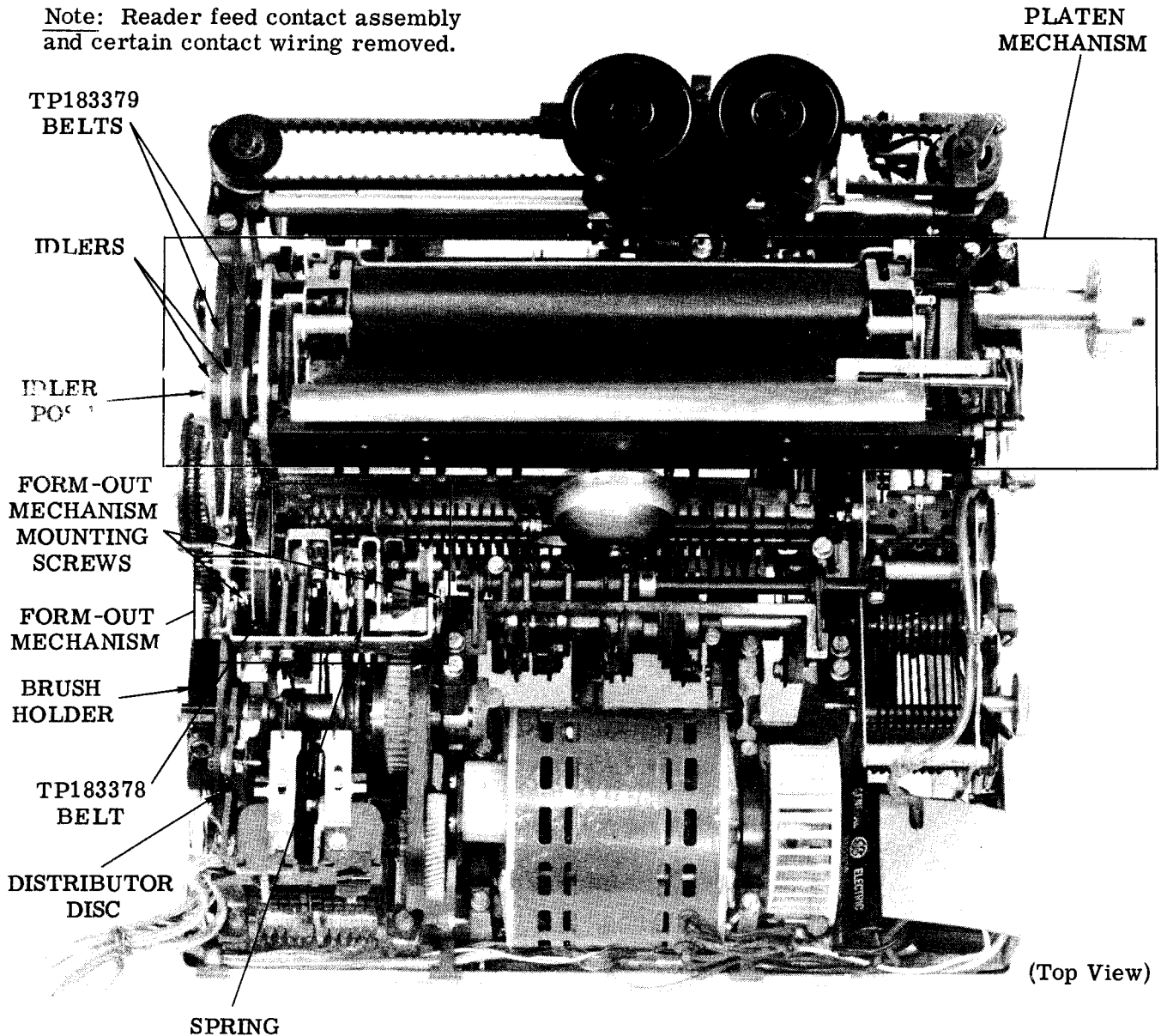

Figure 5 - Typing Unit

Note: On Automatic Send-Receive Teletypewriter Sets, remove the front TP152893 and loosen the rear TP152893 contact bracket mounting screws which secure the tape reader feed magnet contact assembly to the typing unit. Rotate the tape reader feed magnet contact assembly out of the way clockwise, as viewed from the right.

(c) Loosen the two TP180989 distributor disc mounting screws and pull the distributor disc out of the way.

Note: It is not necessary to remove wires from the distributor disc.

(d) Loosen the TP3598 nut on the TP183351 idler post. Back off the two TP183341 idlers.

(e) Slip the two TP183379 belts off the sprockets.

(f) Loosen the three TP151630 form-out mechanism mounting screws.

(g) Slip the TP183378 belt off main shaft sprocket.

(h) Disengage the TP90891 spring from form-out latchlever assembly.

- (i) Gently work form-out mechanism upward and remove it.
- (j) To replace the form-out mechanism, reverse the procedure used to remove it.

Note 1: When tightening the three distributor disc mounting screws, be sure that the longer edges of the TP180676 speed nuts are horizontal with the base casting.

Note 2: The TP186747 downstop bracket (Figure 6) is for factory use only. If the form-out mechanism is removed from the unit as an assembly and the TP186747 downstop bracket is not removed or its mounting screw loosened, the form-out mechanism may be reinstalled in the same unit, using the TP186747 downstop bracket as a stop against the TP183433 bracket. However, if the TP186747 downstop bracket is removed or its mounting screw loosened, it is recommended that the downstop bracket, mounting screw, and flat washer be discarded.

TRIP SHAFT MECHANISM

2.16 To remove trip shaft mechanism (Figure 4), proceed as follows.

- (a) Loosen the four TP180798 mounting screws, two in the left and two in the right mounting bracket. Push inward on brackets and lift mechanism from base casting.

- (b) To replace trip shaft mechanism, reverse procedure used to remove it.

SELECTOR MECHANISM

2.17 To remove selector mechanism (Figure 7), proceed as follows.

- (a) Install the TP184098 selector cam removal tool as described on instruction label.

- (b) Remove the TP150040 mounting screw with lockwasher from selector clutch.

- (c) Remove selector clutch from main shaft by pulling clutch to left and rotating it back and forth.

- (d) From underside of base casting, remove the TP180798 mounting screw from bottom of left platen support post. Loosen

the TP180798 screw in top of post and remove it and dashpot cylinder.

- (e) Loosen the TP181246 mounting screw in the TP180648 follower arm. Slide arm off trip shaft.

- (f) Loosen the TP180798 mounting screw and remove the TP180682 upstop bracket. Tighten screw to secure the TP181230 retaining plate.

- (g) Remove the three TP180675 mounting screws with the TP180676 speed nuts from selector plate.

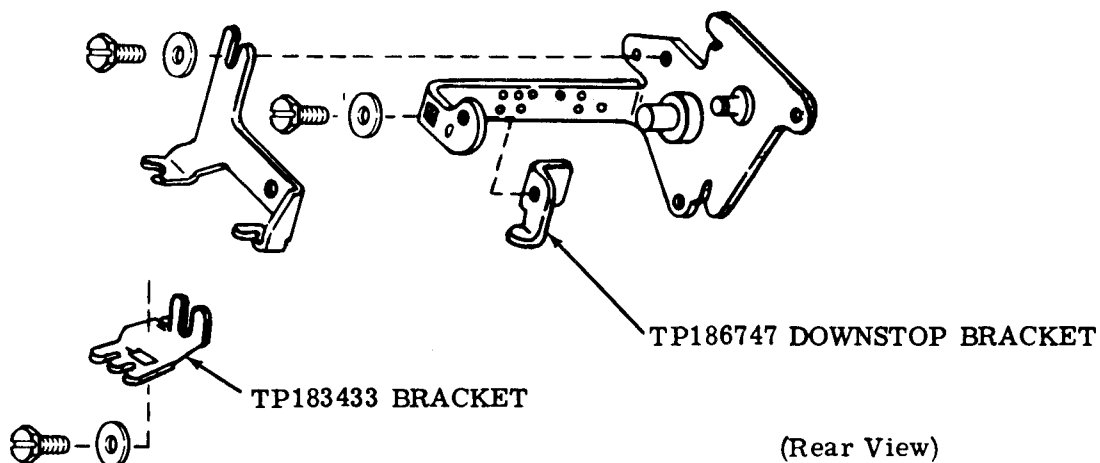
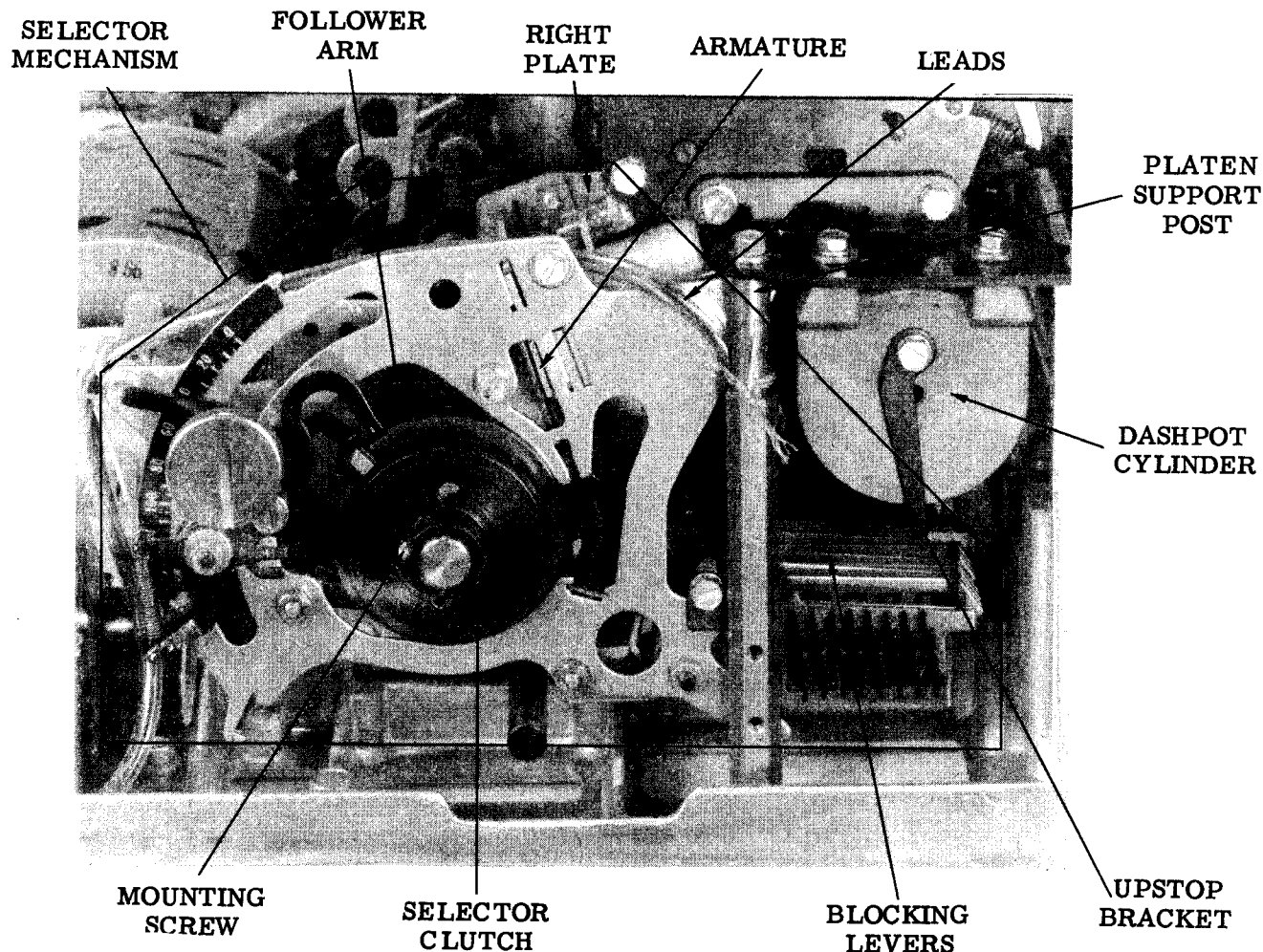

Figure 6 - Downstop Bracket on Form-Out Mechanism



(Left Side View)

Figure 7 - Selector Mechanism

- (h) Remove the two leads from the selector magnet.
- (i) Remove selector mechanism.
- (j) To replace selector mechanism, reverse the procedure used to remove it but with following precautions.
 - (1) Make sure blocking levers are properly seated to guide slots in the front TP180950 codebar tie bracket.
 - (2) To prevent right plate from bending, make sure it is properly fitted around the TP181006 bearing on main shaft.

MAIN SHAFT MECHANISM

- 2.18 To remove main shaft mechanism (Figure 8), proceed as follows.
- (a) Remove trip shaft mechanism (2.16).
 - (b) Remove selector mechanism (2.17).
 - (c) Remove motor (2.19).
 - (d) Remove form-out mechanism (2.15).
 - (e) Remove the TP3598 nut and flat washer from the TP180546 pivot shaft on carriage drive bail. Disengage front end of the TP181005 drive link from pivot shaft.

- (f) Remove the TP119651 retaining ring from function rocker shaft TP180774 drive arm. Disengage the TP180746 arm on function rocker shaft from drive arm.
- (g) Position main shaft mechanism to the right and lift it from base casting.
- (h) To replace main shaft mechanism, reverse procedure used to remove it. Make sure distributor shaft is properly positioned to left against pressure of brush spring.

MOTOR

2.19 To remove motor (Figure 8), proceed as follows.

- (a) Remove the four TP180798 mounting screws and the two TP181383 motor clamps.
- (b) Disengage motor belt from gear pulley mounted on motor housing.
- (c) Loosen the TP180798 screw in motor start relay.
- (d) Remove motor, motor capacitor, start relay, and associated wiring.
- (e) To replace motor, reverse procedure used to remove it.

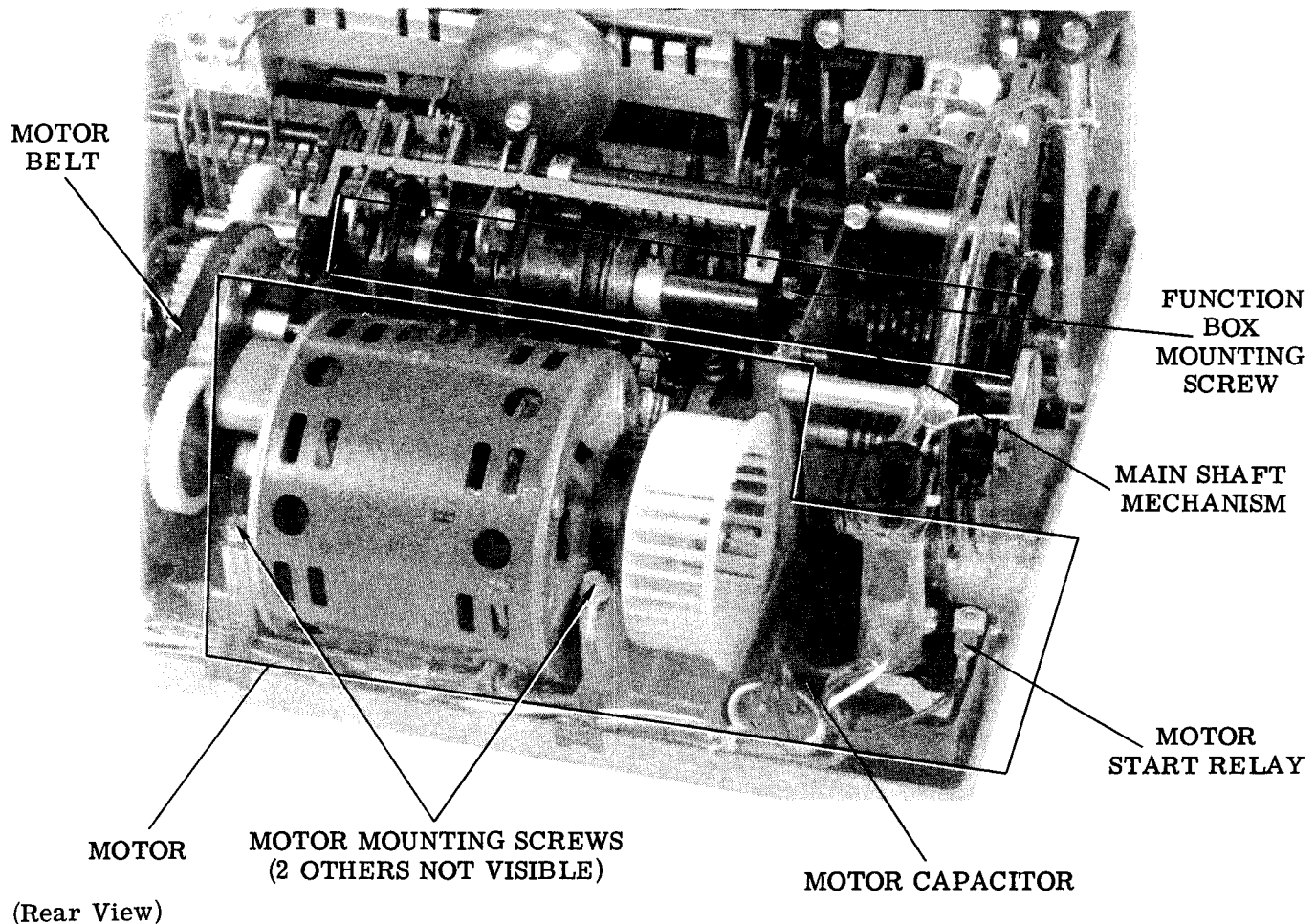

Figure 8 - Typing Unit

33 CALL CONTROL UNIT

GENERAL DESCRIPTION

AND OPERATION

CONTENTS	PAGE
1. GENERAL	1
2. DESCRIPTION AND OPERATION	1
CALL CONTROL UNIT FOR CIRCUIT SWITCHING SERVICE	1
A. Neutral Operation	1
B. Polar Operation	3
CALL CONTROL UNIT FOR SWITCHED NETWORK SERVICE	4
CALL CONTROL UNIT FOR PRIVATE WIRE SERVICE	10
CALL CONTROL UNIT FOR COMPUTER INPUT/OUTPUT SETS	12

1.04 References to left, right, front, or rear consider the call control unit as viewed by the operator.

1.05 This equipment is intended to be operated in a room environment within the temperature range of 40° F to 110° F. Serious damage to it could result if this range is exceeded. In this connection, particular caution should be exercised in using acoustical or other enclosures.

2. DESCRIPTION AND OPERATION

CALL CONTROL UNIT FOR CIRCUIT SWITCHING SERVICE (Figure 1)

2.01 The call control unit for Circuit Switching Service utilizes two types of signals in its operation. Over short and intermediate length telegraph loops it operates on neutral signals; over longer loops with excessive distortion it operates on polar signals. A polar adapter attached to the call control unit enables it to operate on polar signals. Paragraphs 2.02 through 2.14 describe the neutral operation. Paragraphs 2.15 through 2.20 describe the polar operation.

A. Neutral Operation

Controls

2.02 The controls on the call control unit used to originate and handle calls consists of a set of push-buttons and dialer. In certain applications the pushbutton designations are, from left to right, as follows: START, DIAL, LOCAL, and CONN(STOP). In other applications the pushbutton designations are, from left to right: REQUEST, CONN, LCL, and DISCONN.

Dialer

2.03 The dialer is a conventional telephone type which operates normally closed pulsing contacts. These contacts open and close to send dialing pulses during the dial run-down interval. The pulses are produced at a rate of ten per second with the contacts open for 0.006 + 0.003 second during each pulse interval. A pair of normally open off-normal contacts close when the dial wheel is rotated from its idle position. These contacts provide a steady mark current

1. GENERAL

1.01 This section provides a general description and operation of the 33 call control units. It is reissued to add environmental temperature circuits and information on the call control unit for Computer Input/Output Sets. Marginal arrows indicate changes and additions.

1.02 This section describes four call control units which may be considered basic units. They are:

- (1) Call Control Unit for Circuit Switching Service
- (2) Call Control Unit for Switched Network Service
- (3) Call Control Unit for Private Wire Service
- (4) Call Control Unit for Computer Input/Output Sets

1.03 The call control unit is the electrical link which joins the various components of the set to one another and the set to the transmission facilities.

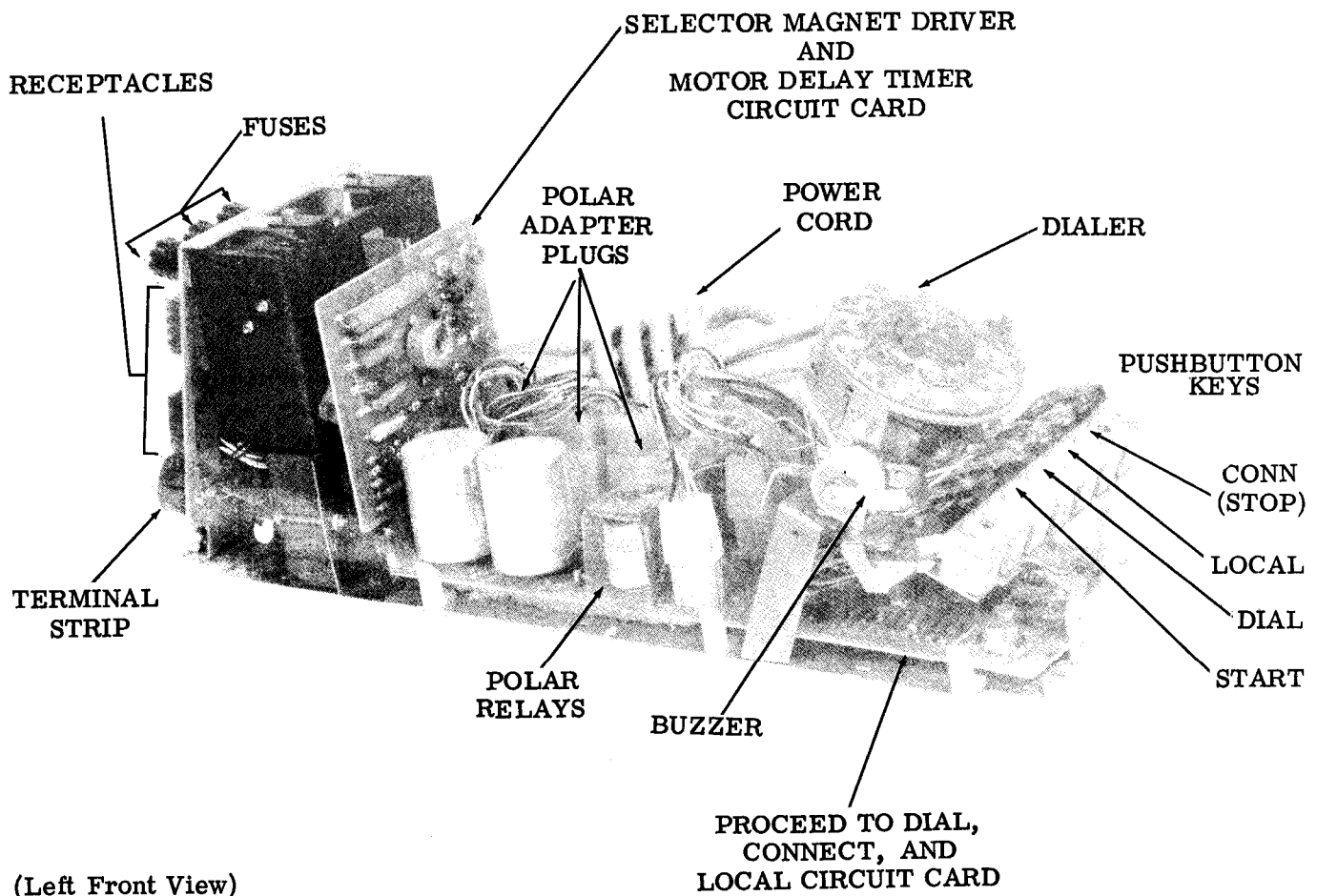

(Left Front View)

Figure 1 - Call Control Unit for Circuit Switching Service

to "blind" the selector when dialing is undertaken. This prevents the printing of spurious characters if dialing is necessary when in the connected condition as in multiaddress calling.

Start

2.04 In the idle condition, with the motor and typing unit stopped and visual indicators de-energized, there is a positive current of 0.005 ampere in the telegraph loop. When the calling station operator depresses the START pushbutton, it causes the shunting of a major portion of the loop resistance, and the loop current increases to 0.060 ampere. The START pushbutton must be held in the depressed position, while switching apparatus in the telegraph exchange is made available. When the circuit is ready, the telegraph exchange interrupts the 0.060 ampere loop current for about 0.025 second. This "proceed-to-dial" signal causes the DIAL lamp to be illuminated at the calling station, and it locks in the shunt to the loop resistance so that the operator may now release the START pushbutton and proceed to dial

the number of the called station. Rotation of the dial transmits signals consisting of no current for 0.06 second followed by full current (0.060 ampere) for 0.04 second during each dial pulse interval. When dialing is completed, the exchange furnishes the connection and signifies this by reversing the telegraph loop current from positive to negative which causes the typing unit motor to start and the CONN lamp to light. Message transmission can now be exchanged between the connected teletypewriters. The line signals are 0.060 ampere marking and zero current spacing.

2.05 If the distant called station is busy or disabled at the time of a call, the local telegraph exchange reverses the local loop current from positive to negative for about 0.2 second and then causes it to revert to positive current again. This causes the local motor to start and the CONN lamp to light momentarily, but they then both turn off. The teletypewriter returns to the idle condition as the positive current is detected.

Connect

2.06 The local telegraph exchange responds to an incoming call by reversing the idle signal loop from positive to negative current. At the local station, the CONN lamp is illuminated, and the motor is turned on as the shunt to the loop resistance is applied in response to the current change. Message transmission can now take place with unattended service at the receiving station.

Stop

2.07 Following completion of traffic a disconnect can be originated from either the calling or the called station. Holding the STOP pushbutton depressed causes the line to go open (zero current). In approximately 3 seconds the local exchange causes the connection to the distant station to be broken, and it reverses the current in the local loop so that positive current flows – limited by the local station loop resistance. This turns off the motor and extinguishes the CONN lamp. The STOP pushbutton is released after the CONN lamp goes out. The original idle condition is now restored. When a disconnect is initiated from a remote station, the local exchange recognizes the open line interval and breaks the connection. The loop current is reversed back to positive, and the local station is returned to the idle condition as stated above.

Local

2.08 Local Operation is provided by depressing the LOCAL pushbutton until the LOCAL lamp is turned on. This places the teletypewriter in an off-line operating condition for copy preparation, practice, or maintenance purposes. To return to the idle condition, the STOP pushbutton is held operated until the lamp is extinguished, or a call can be initiated by depressing the START pushbutton directly. If a call is received while the teletypewriter is in the local condition, the buzzer will sound for an interval of 2.6 seconds, and the teletypewriter will automatically shift over to the call-connected condition with the CONN lamp illuminated.

Fuse Protection

2.09 Three fuses protect the components in the call control unit from accidental shorts or overloads. The selector magnet driver fuse is 0.375 amp, slow blowing, protecting the SMD circuit; the typing unit motor fuse is a 3.2 amp, slow blowing; the third fuse is the ac line fuse, 3.2 amp, slow blowing.

Electrical Interconnections

2.10 There are eight nylon terminal blocks at the rear which serve to interconnect the set components to the call control unit. Also located at the rear is a terminal strip for the signal line and ac power connections.

Circuits

2.11 There are three basic and two auxiliary circuits in the call control unit. The three basic circuits are: The proceed to dial circuit; the connect circuit; and the local circuit. The two auxiliary circuits are: the selector magnet driver circuit and the motor delay timer circuit.

2.12 The three basic circuits are essentially binaries (flip-flops) that have been modified to perform a specific function. They are protected with a diode arc suppressor against transients and voltage pulses generated by their associated relays and coils. They are protected from transient noise induced into them from leads in the cable to the dial, pushbutton keys, and lamp assembly. A low-pass filter or delay network of the RC type is placed in the feedback loop in each binary. The delay network slows the response time of the associated binary (0.001 second in the proceed to dial circuit; 0.02 second in the connect circuit). This reduces its susceptibility to noise. The signal line inputs are filtered against spurious noise occurring on the signal line.

2.13 The selector magnet driver circuit delivers marking signals of 0.500 ampere and spacing signals of essentially 0 ampere to the typing unit selector magnet. The signals trigger the selector magnet driver circuit at about half the current level for normal (0.060 ampere mark) neutral input signals. In teletypewriters modified for polar operation, the signal is applied to polar-to-neutral converting circuits and then to the selector magnet driver. The selector magnet driver circuit thus functions as an amplifying relay which improves the margin of operation over either neutral or polar line circuit.

2.14 The motor delay timer circuit provides a means to delay motor turn-off in the set. This allows the set to complete its printing cycle and come to rest before the motor begins to stop. This circuit is mounted on the same circuit card assembly with the selector magnet driver, but the circuit is electrically independent of it. At 25 degrees C with 390 ohm output load, the delay of the motor delay timer is from 0.475 second to 0.675 second when the supply voltages are within 3 percent of their nominal values.

B. Polar Operation

2.15 Call control units that are modified for polar operation respond to and transmit polar telegraph signals on separate receiving and sending legs extending to the telegraph exchange facilities. The operating conditions and sequence are similar to that for neutral signaling.

2.16 In the idle condition the sending and receiving legs each have from 0.015 to 0.040 ampere positive current flowing. The sending leg current is supplied by the call control unit, and the receiving leg current is supplied by the central exchange. At the local station the polar adapter

interconnects the legs with the neutral signaling control and teletypewriter circuitry. Operation of the START pushbutton causes the current in the sending leg to reverse to a negative polarity with a value equal to the positive current formerly applied (0.015 to 0.040 ampere). The telegraph exchange responds by reversing the current to negative on the receiving leg for 0.025 second. This causes illumination of the DIAL lamp at which time the START pushbutton should be released. The dialing signals go out over the sending leg in polar form with each pulse interval consisting of 0.06 second of positive current followed by 0.04 second of negative current. When the connection is completed, the exchange reverses the polarity of the receiving leg from positive to negative current. After 0.08 second of this reversal, the call control unit causes the motor to turn on, and the CONN lamp to be illuminated. Traffic can now be exchanged. Each station is arranged to record its transmitted copy. Transmitted and received signals consist of positive current for space and negative current for mark on both signal legs.

2.17 When receiving an incoming call, the local exchange reverses the receiving leg current from positive to negative. The local call control unit, after 0.08 second of negative current, turns on the motor and the CONN light and causes the sending leg current to be reversed from positive to negative.

2.18 If the distant station that is called is busy, it will result in the momentary application of negative current to the local receiving leg followed by a return to a continuous positive current. The motor may run briefly, but the teletypewriter will be quickly placed back into the idle condition.

2.19 In effecting a disconnect, operation of the STOP pushbutton causes the transmission of positive current on the sending leg. The exchange will then reverse the current on the receiving leg to positive as it breaks connection to the distant station. The call control unit detects the positive current. After 1.3 seconds it turns the motor and CONN lamp off as it applies a steady positive current to the sending leg and restores the teletypewriter to the idle condition. If the disconnect is initiated at the distant teletypewriter, the positive current disconnect signal, when applied to the local receiving leg, causes the local teletypewriter to go into the idle condition after 1.3 seconds, and the sending leg becomes positive again.

2.20 For local operation the interval conditions are the same as for neutral signaling. Externally, the signal legs remain on positive current unless a call is received. When a call is received, a negative current on the receiving leg for 0.08 second causes the buzzer to sound for 2.6 seconds. Following the buzzer sound, teletypewriter shifts to the call-connected condition.

2.21 Technical Data

Dimensions (Approximate)

Width 5 inches
 Length 17 inches
 Height 6 inches

Input 115 v ac + 10%, 60 Hz + ½%
 Polar adapter input 115 v ac + 10%, 60 Hz

Power consumption

Neutral operation . . . not exceeding 22.5 watts
 Polar operation not exceeding 52.5 watts

Environmental conditions 40° F to 110° F
 ambient temperature

CALL CONTROL UNIT FOR SWITCHED NETWORK SERVICE

2.22 The call control unit for switched Network Service (Figure 2) supplies dc signals to a data set. The data set modulates these signals into tone frequencies which are transmitted over the telephone lines. A data set at the receiving station demodulates the tone frequencies back to dc signals which are then handled by the call control unit for operation of the teletypewriter set. For a better understanding of the call control unit paragraph 2.23 briefly describes the data set.

2.23 Start-stop dc signal pulses form essentially a square wave which cannot readily be transmitted over telephone lines. The data set is basically a converter which changes the dc signals from the sending or calling station into frequency-shifted tones for transmission over the telephone network. A marking pulse from a sending station is converted to a 1270-hertz marking signal (F1 mark) and a spacing pulse becomes a 1070-hertz spacing signal (F1 space). The data set at the receiving or called station sends a 2225-hertz marking signal (F2 mark) and a 2025-hertz spacing signal (F2 space). During transmission of a message the calling station sends a mark and space tones (F1 mark and space) while the called station sends a continuous mark tone (F2 mark). In this way the telephone facilities are operated on a full duplex basis. If the signal received at either station (F1 mark and space at the called station and F2 mark at the calling station) shifts to a space tone for more than one second, or if the received signal is lost for one second, the data set will cause the station to be disconnected. This provides assurance that the connection is maintained for the entire period of message transmission.

2.24 The call control unit used with the data set operates with conventional telephone central offices that have the necessary routing and accounting facilities.

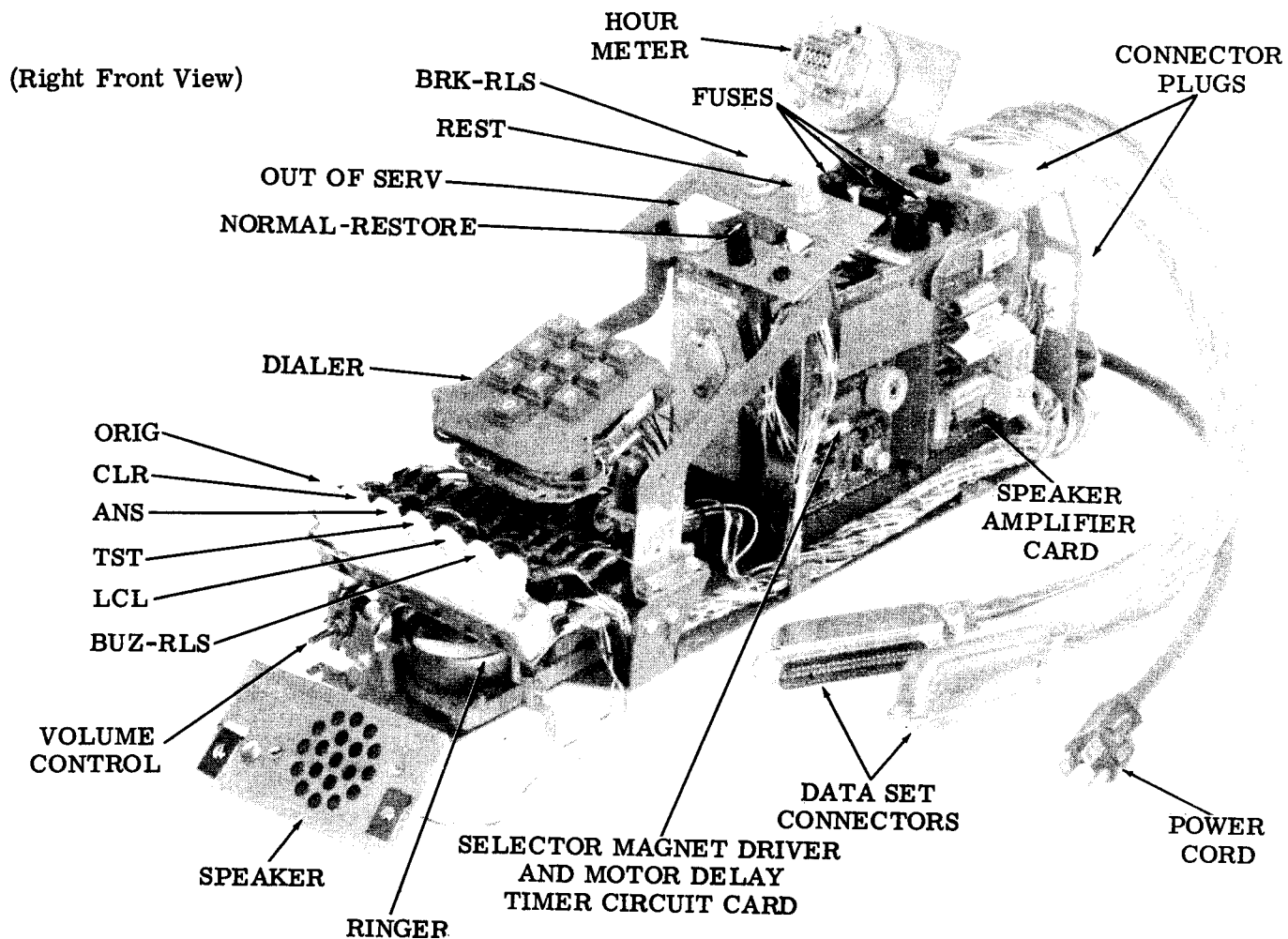
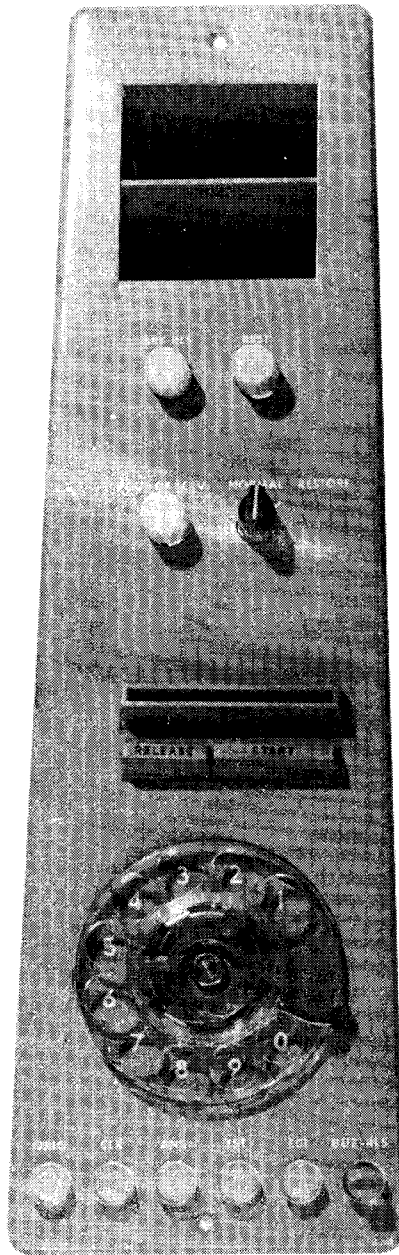

Figure 2 - Call Control Unit for
Switched Network Service

In operation, a call is originated by depressing the ORIG pushbutton (Figure 3). A lamp illuminates the pushbutton and the dial tone will be heard through a loudspeaker. If the line is busy, a busy signal will be heard and the clear (CLR) pushbutton (nonlocking) should be depressed. If the line is not busy, the operator dials the number of the desired station. This causes the called station to go into connect condition. If the teletypewriter is manually operated, the called station operator presses the answer (ANS) pushbutton (nonlocking). Following a short interval, about 1-1/2 seconds, in which telephone facilities are connected, the called station transmits a mark tone (F2) and receives a mark tone (F1) from the calling station. Receiving the continuous F2 mark tone from the called station for 1 second causes the

calling station to go into connect condition, and its motor is turned on. Likewise, the continuous F1 mark tone from the calling station for 1 second causes the called station to go into connect condition, and its motor is turned on. Either station can now transmit.

2.25 At the end of the message, either station may originate a disconnect by depressing the CLR pushbutton, (Figure 3) at which time each station goes back to its idle condition, ready to receive or originate other calls. For keyboard practice, maintenance purposes, or preparation of copy, the local mode (LCL) pushbutton (locking) is depressed. This turns on the motor and disables automatic answering facilities, if present. In the event of an incoming



ROTARY DIALER

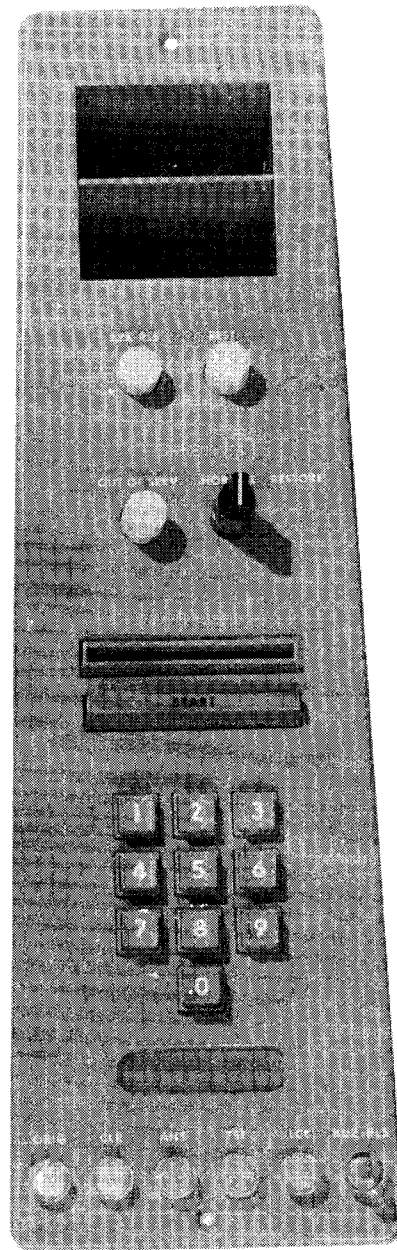

TOUCH-TONE® DIALER

Figure 3 - Call Control Panels

call during local operation, the call control unit responds to ringing signals and the ANS pushbutton must be operated manually. Operation of the test (TST) pushbutton (locking) causes received signals to be retransmitted to the test center for maintenance purposes. A lamp, associated with each pushbutton, illuminates the pushbutton whenever that pushbutton has been operated and the operating condition exists. The ANS lamp is pulsed in response to ringing signals of an incoming call, and lights continuously when the call is answered. The CLR lamp is automatically extinguished 1.5 seconds after the pushbutton has been depressed, and disconnect is completed.

2.26 A steady mark signal blinds the associated teletypewriter during all intervals, except when in the connect condition. This prevents spurious characters from being printed except when due to loss of signals, circuit noise, or deliberate break or space-disconnect signals.

Progress of a Call

2.27 To originate a call, the ORIG pushbutton (Figure 3) is momentarily depressed. This connects the station to the line and lights the ORIG lamp. During the period of time in which connection is being made, the telephone central office makes no time measurements. When the ORIG pushbutton is closed, the call control unit is connected to the telephone line through the data set and an off-hook condition is set up. The amplifier is connected into the circuit so that the dial tone from the central office is heard. The called station is dialed while the amplifier monitors the progress.

2.28 At the called station audible and visible signaling devices are operated. The called station goes off hook and into the connect condition upon operation of the ANS pushbutton circuit, by manual or automatic means, at the distant point. At this time, there is a nonsignaling interval of 1.225 seconds during which accounting and toll recording facilities at the telephone exchange will be cleared. Following the nonsignaling interval, the called station transmits its F2 mark tone and sets its monitoring timer to respond to the F1 mark tone from the calling station. When the continuous F2 mark tone is received at the calling station for a period of 1 second, indicating that a station has answered, it will go into the connect condition and turn on its motor. When the continuous F1 mark tone is received at the called station for an interval of 1 second, it will go into the connect condition. The station may now acknowledge the call either by operator keyboarding, or by automatic answer-back message transmission. The monitoring timers at both stations are set to respond to reception of a space tone from the distant station. Traffic can now be exchanged from either station on a half-duplex basis.

Disconnecting a Call

2.29 During the time the two stations are connected (traffic interval), either station can initiate a disconnect as follows:

(a) A call is normally terminated by the end-of-transmission (EOT) code combination which provides fast disconnect without introducing hit characters. This is accomplished by the data set in response to EOT contact closures in function boxes of both the sending and receiving teletypewriters.

(b) A call connection can also be cleared manually by momentarily depressing the CLR pushbutton (Figure 3). Operation of the CLR pushbutton at either station will cause transmission of a spacing signal of 1.5 seconds duration, after which the station originating the disconnect will discontinue its tone transmission and go back on hook. The other station, after receiving the spacing signal for 1 second, will automatically transmit its 1.5-second spacing signal and then go on hook. Both stations will then be back in their original idle condition in which calls can be either originated or accepted.

Answering a Call

2.30 To answer a call manually, momentarily depress the ANS pushbutton (Figure 3). This connects the station to the line and lights the ANS lamp. The lamp remains lighted until the answer mode is terminated. Manual answering is necessary only when the automatic answer-back circuit is disabled. The automatic answer-back circuit is disabled by low-paper contacts, data set relay contacts (when in local mode), and the OUT OF SERV. key.

2.31 Call control units equipped with automatic answering facilities will respond to received ringing signals, turning the teletypewriter on at the end of the ringing interval and proceeding through to the connect condition. Automatic message answer-back is a part of this feature. The presence of an operator is required in order to complete disconnect and return the teletypewriter to idle condition. For unattended service, an automatic disconnect timing device (optional) actuated when a call is answered, will cause the teletypewriter to go through the connect condition, send the 1.5-second spacing tone, and go back on hook if the F1 mark tone is not received within 8 seconds after the called station answered. This is designed to prevent the unattended station from being made busy by (telephone) calls that fail to cause a full connection to be set up. This feature does not affect normal automatic disconnect upon receiving the 1-second spacing tone or loss of tones due to a dropoff.

Local Mode

2.32 The local mode (LCL) provides off-line operation of the teletypewriter. The operator selects the local mode by depressing the LCL pushbutton (Figure 3). This lights the LCL lamp and operates the motor control relay (MCR) to energize the motor. The data set connects the sending circuit to the receiving circuit and enables the keyboard and answer-back to transmit. In this condition the teletypewriter can be used for preparing copy, for operator practice, or for maintenance purposes. If an incoming signal is received during this time, ringing signals are received and manual operation of the ANS pushbutton is required in order to receive the message. If the teletypewriter is in a terminal hunting group, the operator must turn the out-of-service (OUT-OF-SERV.) knob to the RESTORE position momentarily and then to NORMAL.

OUT OF SERV. Switch

2.33 The OUT OF SERV. switch (Figure 3) prevents the automatic answering of incoming calls. In its NORMAL position (arrow on knob upright), it has no effect or function; in the OUT OF SERV. position (knob rotated counterclockwise and detented) it sets the following conditions:

- (a) A contact is closed that causes the OUT OF SERV. lamp to light.
- (b) A contact is closed that shorts the ringer coils. This makes the ringer inoperative. As an option the contact can be located to shunt both the ringer and series capacitor (ie, the telephone line). This makes the station appear to be in an off-hook condition or busy to the central office.
- (c) A contact is opened that breaks the automatic answer circuit to the answer relay. This prevents the relay from operating in response to the ring-up relay and thus the teletypewriter will not answer.

2.34 For stations that are not in terminal hunting groups, the operator may return the teletypewriter to service by turning the OUT OF SERV. knob to the NORMAL position. For terminal hunting stations, however, the operator must turn the knob to the RESTORE position and hold it until a dial tone is heard. In this position:

- (a) A contact is closed that shorts the tip to ring (off-hook condition). This condition is detected by the central office which then releases the teletypewriter from lockout and applies the dial tone.
- (b) A contact is closed that completes a path from the speaker amplifier to ground. This permits the amplifier to pass the line signals (dial tone).

The OUT OF SERV. switch is then restored to NORMAL.

Low-Paper Alarm

2.35 A low-paper alarm is provided in the teletypewriter. When a low-paper condition occurs, make contacts in the low-paper switch provide ground to the low-paper buzzer, permitting it to operate. Depressing the buzzer-release (BUZ-RLS) pushbutton (locking) in the call control unit (Figure 3) silences the buzzer and causes the BUZ-RLS lamp to light. Attempting to release the pushbutton without replenishing the paper supply will result in the buzzer operating. When the paper has been replenished, the teletypewriter is returned to normal by releasing the BUZ-RLS pushbutton.

2.36 Break contacts on the low-paper switch disable the automatic answer-back circuit. The operator can override this condition by answering manually. If the low-paper alarm occurs during a call the operator has the option of completing the call before changing the paper, or interrupting the call. To interrupt the call, the operator stops transmission by depressing the keyboard BREAK key, and then depressing the BRK-RLS pushbutton to notify the distant station of the problem. The connection is cleared by simultaneously operating the control (CTRL) and EOT keys on the keyboard. Turning the OUT OF SERV. knob to the detent position insures that the teletypewriter will not automatically answer a call while paper is being replenished.

2.37 To restore the teletypewriter to service after the paper has been inserted, depress the CLR pushbutton and return the OUT OF SERV. knob (Figure 3) to its NORMAL position. (For teletypewriters in terminal hunting groups, turn the knob to its RESTORE position and hold it there. When dial tone is heard, release the knob.) The teletypewriter is now in a normal idle operating position.

Restrain Lamp

2.38 This high intensity restrain (REST) lamp (Figure 3) lights when a restraining signal is received from an 8-level to a 5-level converter used in transmission to 5-level TWX stations on the DDD switching plan. The lamp remains lighted until the restraining signal is removed. The purpose of this feature is to limit the sending speed from 8-level teletypewriter transmitting at 100 wpm to 5-level teletypewriters receiving at 60 wpm.

Test Mode

2.39 If the TST pushbutton (Figure 3) is operated while the teletypewriter is connected to a test center, the message sent by the test center will be recorded on the teletypewriter and turned around and sent back for analysis. This is accomplished by connecting the teletypewriter to the data set through a set of transfer contacts and a break contact to ground. This type of operation can be terminated by momentarily operating any of the nonlocking pushbuttons which will then release the TST locking pushbutton.

Signal Generation

2.40 The teletypewriter can send by operating the keyboard, answer-back mechanism, or BREAK key (Figure 3). The keyboard signal generator contacts and answer-back contacts are in parallel with the signal generator (distributor) which is, in turn, connected to the data set. The BREAK key connects to the data set via separate leads.

Dialers

2.41 **Pulsing Rotary Dialer:** For rotary dialer applications a pulsing contact of the rotary dialer is inserted into the telephone line. The rotary dialer (Figure 3) is equipped with a normally closed pulsing contact and a normally opened off-normal contact. The pulsing contact is inserted into the telephone line when the station originates a call. When answering the call, a short circuit is applied across the pulsing contact. The off-normal contact is placed across the output of the amplifier and silences the speaker whenever the dialing disc is moved.

2.42 **Pulsing Card Dialer (40A Dialer):** The 40A dialer operates on direct current furnished from the central office. To use the card dialer, the ORIG pushbutton is depressed. After a dial tone has been received, a card with the telephone number punched in it is firmly inserted in the slot. This operation winds a spring which later pushes the card out of the slot as dialing proceeds.

2.43 The card dialer is started by momentarily depressing the START bar. This operates the card dialer start contact and establishes a path from the ring side to the tip side of the telephone line. Sending of the dial pulse means interruptions of the current in the telephone line.

2.44 A scanning drum makes sixteen revolutions, ten for transmitting the digits and six for interdigital time. At the completion of the revolutions, an escapement is tripped which permits the next row of holes on the card to be placed in position for sensing.

2.45 This sequence is repeated at each row as the card advances out of the card dialer. If no "stop" code is punched in the card, the card dialer will continue to advance the card (even if no number code is punched) until the card is released. If the "stop" code is sensed, the card dialer stop contacts operate. The card can be released by operating the RELEASE bar. No attempt should be made to release the card by reoperating the START bar, as this will trigger the card dialer mechanism and place a short circuit across the output of the data set. This shunt will prevent the station from receiving or sending until the card is disengaged. If this condition persists, the data set will disconnect.

2.46 **Pulsing Card Dialer (41A Dialer):** In locations with 60-hertz ac power the 41A card dialer is used. In this dialer the power to operate the commutator disc is

derived from a synchronous motor powered by the 14 v ac source in the teletypewriter. The power to advance the card in the dialer is derived from a spring wound by inserting the card in the slot. The switching functions and the motor control are independent of the signal path. These features result in a superior performance as compared with the 40A dialer.

2.47 To operate the dialer, the card is inserted and the START bar is momentarily operated. The commutator disc begins rotating, and the dial pulses are sent to the line.

2.48 When all the punched codes are sent the disc stops. A mechanical linkage then permits the spring, wound by inserting the card, to advance the card for the next digit to be read and dialed. As the "stop" code is read, the dialing stops. The card can then (as also at any other time) be released by operating the RELEASE bar.

2.49 **TOUCH-TONE Dialer:** For multifrequency (MF) dialing applications, the dialing frequencies generated by the TOUCH-TONE dialer are fed through the loudspeaker amplifier and into the telephone line via the sending amplifier in the data set. As the station connects, the output of the TOUCH-TONE dialer is disconnected from the data set so that there is no hazard connected with improper operation of the TOUCH-TONE dialer at that time.

2.50 The TOUCH-TONE MF signal generated is a 1-transistor oscillator generating two frequencies any time a single pushbutton is operated. Seven frequencies are provided, with each dial digit corresponding to two frequencies according to the table below:

TOUCH-TONE			
Frequencies			
cps	1209	1336	1477
697	1	2	3
770	4	5	6
851	7	8	9
941		10	
			Dial Digits

2.51 The frequencies above 1900 hertz are generated at a somewhat higher level to compensate for greater line loss at those frequencies. There is also a variation or amplitude for various digits.

2.52 TOUCH-TONE and Card Dialer (Figure 3): To use the automatic card dialer, the **ORIG** pushbutton is depressed. After the dial tone has been received, a punched card is inserted into the slot and pushed down. The **START** bar is then momentarily operated. The card dialer proceeds with dialing under power of a spring motor wound by insertion of the card. When a "stop" code is read, the dialing stops. The card should then be released by reoperating the **START** bar.

2.53 The sensing contacts in the card dialer are in parallel with the frequency-determining contacts in the associated TOUCH-TONE dialer. As the card advances out of the slot, the sensing contacts sense the holes punched in the card and thus determine the proper frequencies to be transmitted. This occurs for every row on the card.

2.54 Since the card advances out of the slot very rapidly, there is no need for a separate **RELEASE** bar. When the station connects, relay contacts in the data set disconnect the MF signal input and remove any hazard connected with false operation of the TOUCH-TONE dialer.

Fuse Protection

2.55 Three fuses protect the components in the call control unit from accidental shorts or overloads. The selector magnet driver fuse is 0.5 amp slow blowing; the motor delay timer fuse is 2.25 amp slow blowing; the ac line fuse is 3.2 amp, slow blowing.

Electrical Interconnections

2.56 A number of nylon plugs and a terminal strip located at the rear serve to interconnect the set components to the call control unit. A six foot power cord connects the call control unit to the ac power source.

Circuits

2.57 Selector Magnet Driver Circuits: The data set supplies a 20-ma dc signal to the selector magnet driver associated with the teletypewriter. The selector magnet driver amplifies the signal to 500ma to operate the selector on the teletypewriter. The selector magnet driver is a two-stage triggering regenerative amplifier (or flip-flop) capable of switching high output currents of 0.500 ampere at very closely controlled input current levels. The output of the selector magnet driver is automatically regulated and is essentially independent of normal variations in power supply voltage, and of selector-magnet and current-limiting resistance values.

2.58 Speaker Amplifier Circuit: The speaker amplifier is powered only after the **ORIG** key is operated and is quieted when the Station connects. It has two inputs, one from the telephone line via the buffer amplifier in the data

set limiter and the other from the multifrequency (MF) tone dialer. Three outputs are provided: (1) into the speaker or optional hand-held receiver; (2) into the telephone line through the sending amplifier in the data set; and (3) an auxiliary output into the data set. The line-to-speaker connection permits monitoring of supervisory signals when originating a call. The TOUCH-TONE dial-to-line and TOUCH-TONE dial-to-speaker connection provides for amplification of the outgoing MF dialing signals and for monitoring them during outpulsing. The line-to-second-output connection is provided for the dial tone detector (when furnished). The various connections mentioned are established by switching in the data set and by the common switch in the TOUCH-TONE dialer.

2.59 Technical Data

Dimensions (Approximate)

Width 5 inches
 Length17 inches
 Height 6 inches

→ Input 115 v ac + 10%, 60 Hz
 Environmental conditions40 F to 110 F
 ambient temperature

CALL CONTROL UNIT FOR PRIVATE WIRE SERVICE (Figure 4)

2.60 Power for the motor, selector magnet driver, local power supply, and tape reader power pack, is → supplied from fused 115 volt ac, 50 to 60 hertz power. Direct current of either 0.020 or 0.060 ampere is required for the signal line(s) and for operation in the local mode. The dc power for the signal line(s) is supplied by external facilities, while local dc current for operation in the local mode is furnished through the operation of the local power supply circuit in the call control unit. At the rear of the call control unit is a terminal strip which provides the point of entry for the ac power and the signal line(s) into the teletypewriter set.

↳ **Note:** Call control units used in 3300 Series Coded Sets have the tape reader power pack mounted on them. The power pack consists of a circuit card which is located to the right of the capacitor. In other sets the power pack mounts within the stand underneath the base.

2.61 A 3-position rotary power switch is the only manual control on the call control unit. Its three positions are: **OFF**, **LOCAL**, and **LINE**.

Fuse Protection

2.62 Two fuses protect the components in the call control unit from accidental shorts and overloads. The selector magnet driver fuse is 0.8 amp, slow blowing; the ac power line fuse is 2.8 amp, slowing blowing.

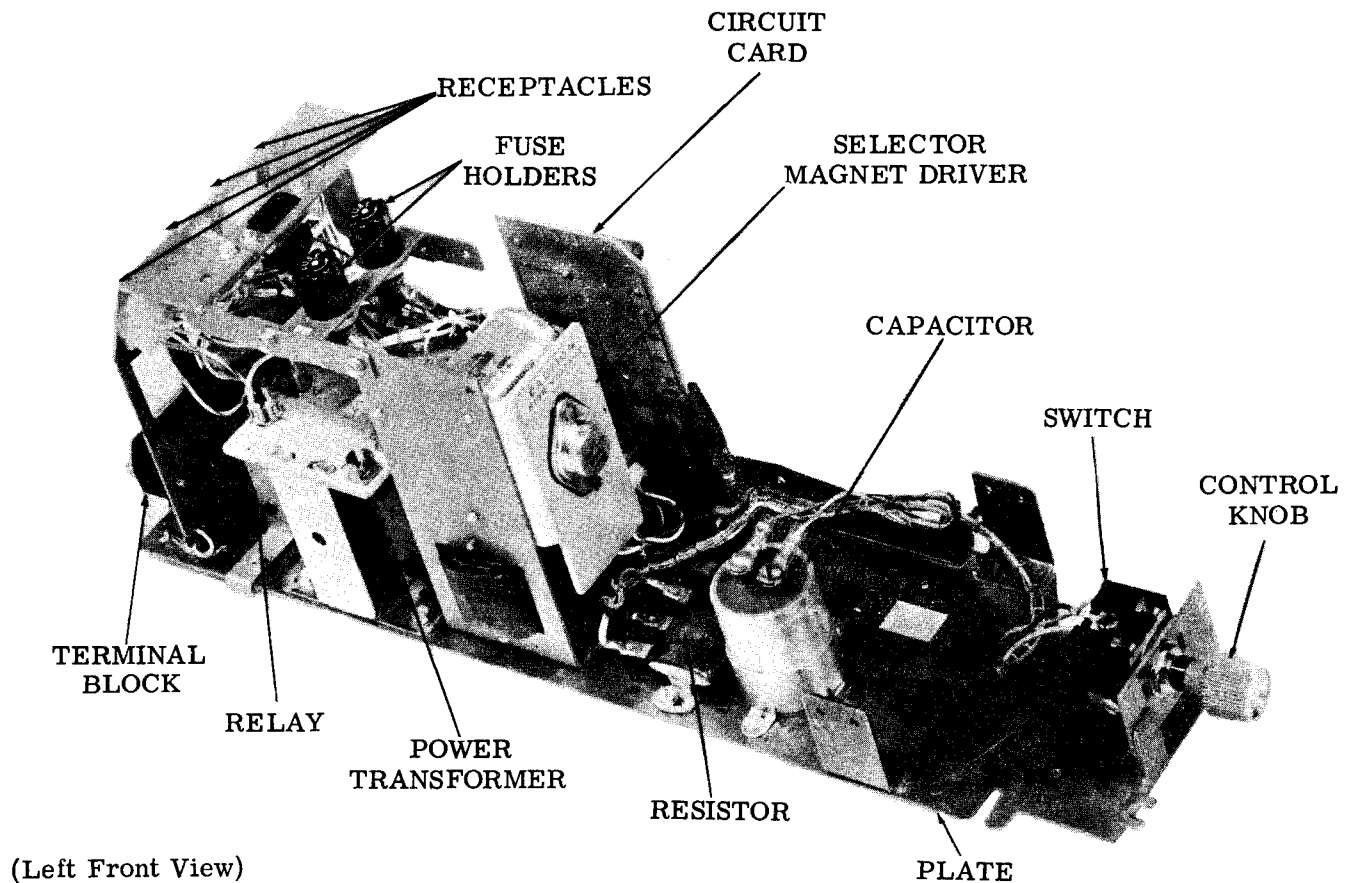

Figure 4 - Typical Call Control Unit for Private Wire Service

Electrical Interconnections

2.63 Connector plugs at the rear of the call control unit serve to interconnect the set components to the call control unit. A terminal strip, also located at the rear, serves to connect the ac power to the call control unit and offers a convenient terminating area for other accessories and external connections.

Line Mode

2.64 When the switch is in the LINE position, the teletypewriter can be placed in the external signal line loop for communication with other teletypewriters. The external signal line loop is united with the selector magnet driver. With dc power on the signal line, and transmission from the keyboard or tape reader will cause the typing distributor to send start-stop signals to other teletypewriters in the external signal loop. Also, the local teletypewriter is able to receive, through the typing unit selector, the

start-stop signals transmitted from other teletypewriters in the signal line loop.

Local Mode

2.65 When the switch is in the LOCAL position, (1) the local battery is supplied to the selector magnet driver and the send circuit, (2) the external signal line loop is divorced from the selector magnet driver, and (3) the external signal line loop is shunted so that other teletypewriters in that loop can communicate without being affected by the operation of the local teletypewriter.

Off Mode

2.66 When the switch is in the OFF position, the signal line is diverted around the local teletypewriter. Other teletypewriters can communicate in the signal loop without interference. All power in the call control unit, except the ac power to the selector magnet driver, is off.

2.67 Technical Data

Dimensions (Approximate)

Length 15 inches
 Width 4 ½ inches
 Height 6 inches

Input 115 v ac, 50-60 Hz
 Environmental conditions 40° F to 110° F
 ambient temperature

CALL CONTROL UNIT FOR COMPUTER INPUT/OUTPUT SETS (Figure 5)

2.68 The call control unit for Computer Input/Output Sets provides the electrical interconnection of the various set components, the interface, and control circuits. The call control unit consists of a circuit board, a power supply, operator control keys, a terminal strip, and plugs to

interconnect the various set components as well as the power source.

2.69 The 20 pin interface connector has the following pin assignment:

- | | |
|-----------------------------|-----------------------|
| A - Send Data (Out) | P - Punch Off |
| B - Receive Data (In) | R - Printer Available |
| C - Remote | T - Reader Available |
| F - Circuit Common | U - Motor Off |
| H - Reader Off | W - Keyboard Off |
| J - E.O.M. (End of Message) | D - Spare |
| K - Spare Wire | E - Spare |
| L - Request | S - Spare |
| M - Printer Off | V - Spare |
| N - Punch Available | X - Spare |

2.70 Voltages and impedances for control and data leads are listed in Figure 6.

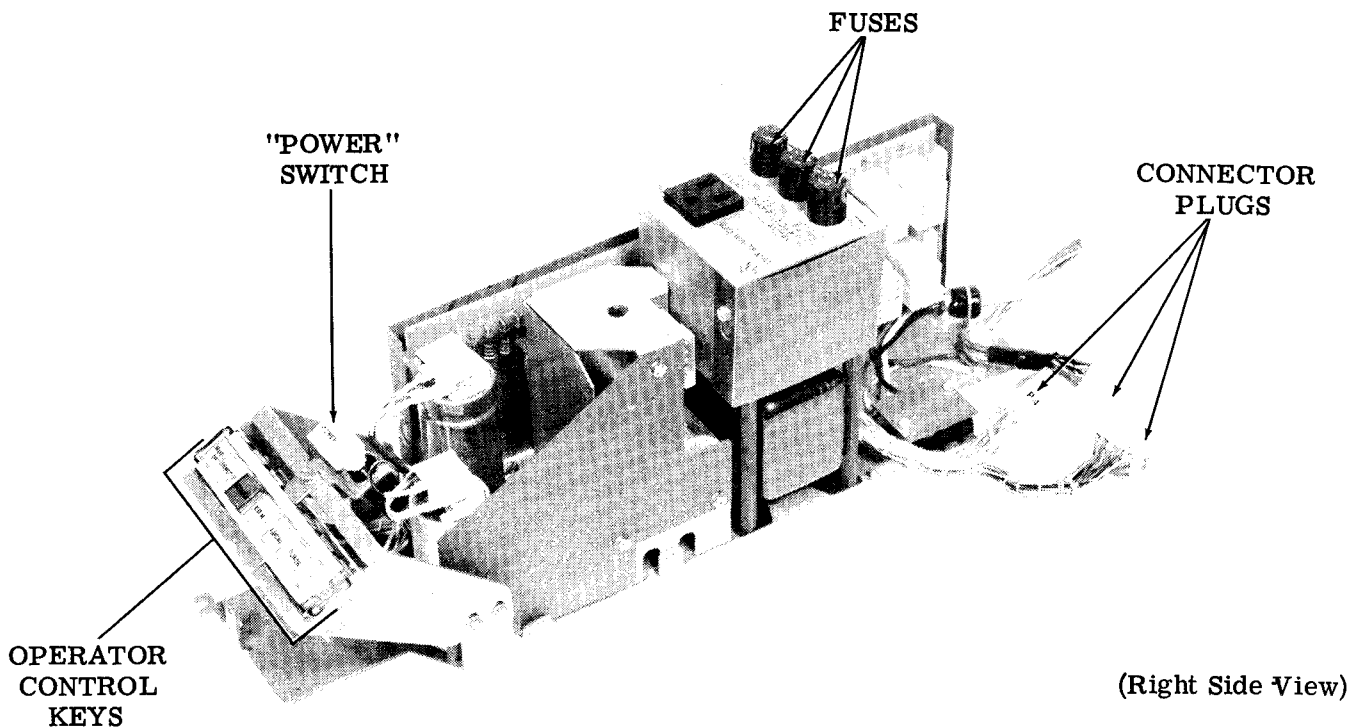

Figure 5 - Call Control Unit for Computer Input/Output Sets

	INPUT				OUTPUT			
	TTY On State		TTY Off State		TTY On State		TTY Off State	
	Max (Mark)	Least	Max (Space)	Least	Max (Mark)	Least	Max (Space)	Least
	+7.0 V	+3.5 V	+1.5 V	-0.5 V	+7.0 V	+3.5 V	+1.0 V	-0.5 V
Computer Impedance to Ground (ohms)	R > 50K		R < 125		450 < R < 550		450 < R < 550	

Figure 6 - Voltages and Impedances for Control and Data Leads

2.71 Operator Controls:

- (a) POWER – Push on, push off key is illuminated red when power is on. Operation of this key closes both sides of the power line activating the 48 v dc and 24 v dc power supplies. Operation of this key also activates the interface leads.
- (b) MOTOR OFF – Locking* key, not illuminated.
- (c) REMOTE – Locking*, white illuminated key whose operation places the set in the remote mode of operation. When in remote mode the teletypewriter communicates with the computer and is capable of receiving serial information with the computer selecting the teletypewriter components for printing only, paper tape operation only, or simultaneous printing and tape perforating. The teletypewriter is also capable, in remote mode, of sending serial information with the computer selecting the tape (reader) sender, while locking the keyboard, or permitting manual entry from the keyboard. The sending line is wrapped to the receiving line to provide local copy in the local mode.
- (d) REQUEST – Momentary, green illuminated key. This key is operated when the teletypewriter is in the remote mode and requesting transmission with the computer.

- (e) E.O.M. (End of Message) – Momentary, white, not illuminated key. The operator depresses this key at the end of the message indicating to the computer that the transmission is complete.
- (f) LOCAL – Locking*, white illuminated key. Operation of this key places the teletypewriter in the local mode for preparation of message tapes and other off-line activities.
- (g) PUNCH – Push on, push off, white illuminated key. This key is operated when the set is in local mode to turn the tape punch on and off. During remote operation this key is not used because the punch responds to on and off signals from the computer.

2.72 Technical Data:

- Input 115 v ac ± 10% 50 or 60 Hz ± 0.75 Hz
- Running Current Less than 3 amperes
- Starting Surge 12 amperes, maximum
- Environmental Temperature range – 40° F to 110° F
- Relative Humidity – 2% to 95%
- Altitude – Sea level to 10,000 Ft.
- Storage Temperature – (-) 40° F to 150° F with altitudes up to 50,000 Ft.

*Note: The three locking keys are mutually exclusive.

33 TAPE READER
 GENERAL DESCRIPTION AND
 PRINCIPLES OF OPERATION

CONTENTS	PAGE
1. GENERAL	1
2. DESCRIPTION	1
TECHNICAL DATA	1
3. PRINCIPLES OF OPERATION	2
OUTLINE OF OPERATION	2
DETAILED OPERATION	3
A. Tape Lid Mechanism	3
B. Control Mechanism	3
C. Distributor Trip Mechanism	5
D. Feed Magnet Mechanism	6
E. Sensing Pin Guide Mechanism	6
F. Contact Block Mechanism	7
G. Tape Feed Mechanism	9
H. Upstop Mechanism	10
4. FEATURES	10
MANUAL READER	10
A. Freewheeling Mechanism	10
B. Tight-Tape Mechanism	10
C. Tape-Out Mechanism	10
AUTOMATIC CONTROL FEATURES	12
A. Local Start	12
B. Remote Start	12
C. Reader Stop	12
D. FREE Position	15

1. GENERAL

1.01 This section provides the general description and principles of operation for the 33 tape reader. It is reissued to include a few minor corrections and to distinguish the power pack for 3300 Series Coded Sets and Computer Input/Output Sets from the power pack pertaining to 33 Sets. Marginal arrows indicate the changes.

1.02 The 33 tape reader is an 8-level electro-mechanical device which senses and transmits coded intelligence perforated in tape (Figure 1).

1.03 References to left, right, front, rear, consider the tape reader as viewed by the operator.

1.04 In the illustrations, fixed pivots are solid black, and floating points — those mounted on parts that move — are crosshatched.

2. DESCRIPTION

TECHNICAL DATA

Note: This equipment is intended to be operated in a room environment within the temperature range of 40°F to 110°F. Serious damage to it could result if this range is exceeded. In this connection, particular caution should be exercised in using acoustical or other enclosures.

2.01 Dimensions and Weight (Approximate)

Feeding and Sensing Component

Width	3-1/2 inches
Depth	4 inches
Height	3-1/2 inches
Weight	2 pounds

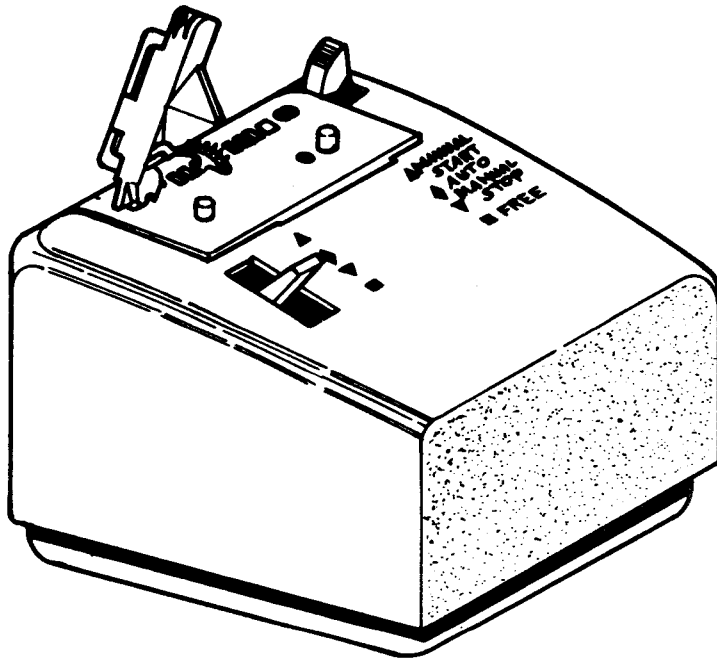

(Left Front View)

Figure 1 - 33 Automatic Tape Reader

Power Pack Component

Width	6-1/4 inches
Depth	2-1/2 inches
Height	2-3/4 inches
Weight	1 pound

2.02 Electrical — Power Pack

High Voltage:

Input	115 volts ac
Output	Min 137 volts dc @ 0.160 ampere

2.03 Feed Magnet

Power dissipation	2-1/4 watts
Nominal attraction time	8 to 11 milli-seconds at a nominal peak transient current of 0.220 ampere
Nominal release time	7 to 10 milli-seconds

CAUTION: HIGH VOLTAGE PERSISTS 10 SECONDS AFTER POWER IS REMOVED.

2.04 Speed 100 words per minute

2.05 Tape Specifications

Level	8-level
Width	1 inch
Code combinations per inch	10
Feed hole diameter	0.0465 inch

2.06 Signal Characteristics

Long telegraph loops	0.015 to 0.070 ampere at 48 to 240 volts dc inductive
Short telegraph loops	0.058 to 0.072 ampere at 16 to 22 volts dc resistive

3. PRINCIPLES OF OPERATION

OUTLINE OF OPERATION

3.01 The tape reader senses coded intelligence perforated in tape and transmits this intelligence as a parallel output.

3.02 The tape reader package consists of three mechanisms; the reader mechanism, the power pack, and the distributor trip mechanism (Figure 2).

3.03 The reader mechanism senses and feeds the tape. Other submechanisms within the reader mechanism transmit the intelligence as a parallel output. The reader mechanism mounts on the left side of the typing unit.

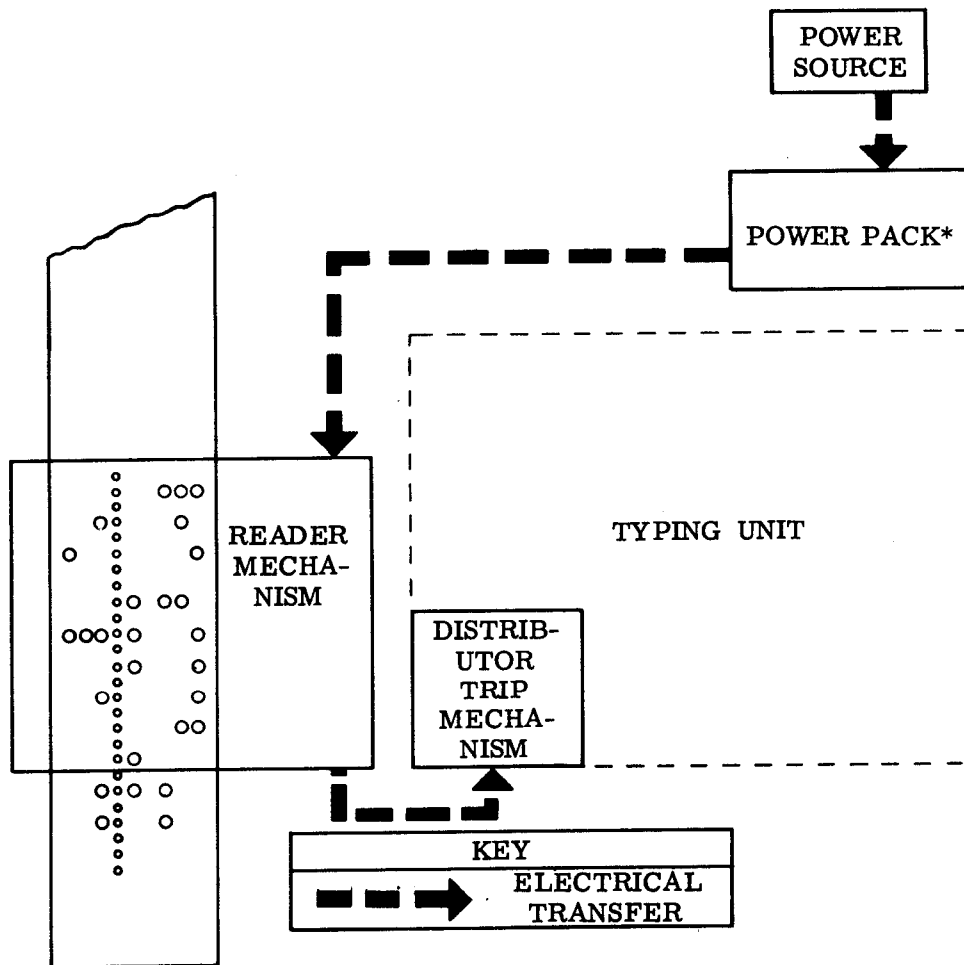

*The power pack for Computer Input/Output Sets and 3300 Series Coded Sets is in the call control unit.

Figure 2 - Tape Reader Package with Major Mechanisms

3.04 The power pack provides current rectification for the reader mechanism. In 33 sets the power pack mounts at the rear of the set underneath the typing unit subbase. In 3300 Series Coded Sets and Computer Input/Output Sets the power pack is a part of the call control unit.

3.05 The distributor trip mechanism receives the reader mechanism output and converts it into serial start-stop signals.

DETAILED OPERATION

A. Tape Lid Mechanism

3.06 When the tape lid latch handle is moved to the right, the spring biased tape lid swings open. Two locating pins guide the tape as it travels above the top of the plate (Figure 3).

B. Control Mechanism

3.07 In the manual reader there are three positions for the control lever: START, STOP, and FREE. In the automatic reader there are four positions for the control lever: MANUAL START, AUTO, MANUAL STOP, and FREE. When the control lever is moved to the START position (MANUAL START position for the automatic reader — Figure 4) the spring biased start contact wires are positioned on the start contact. Since the start contact wires and the start contact are wired in series with the distributor clutch trip coil in the typing unit, the coil energizes and releases the tape reader trip lever (Figure 5).

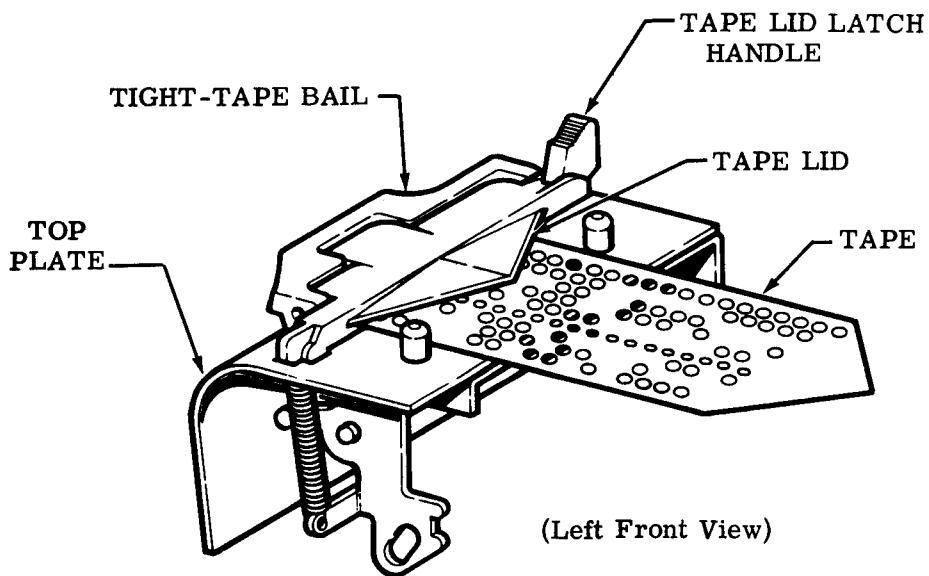

Figure 3 - Tape Lid Mechanism

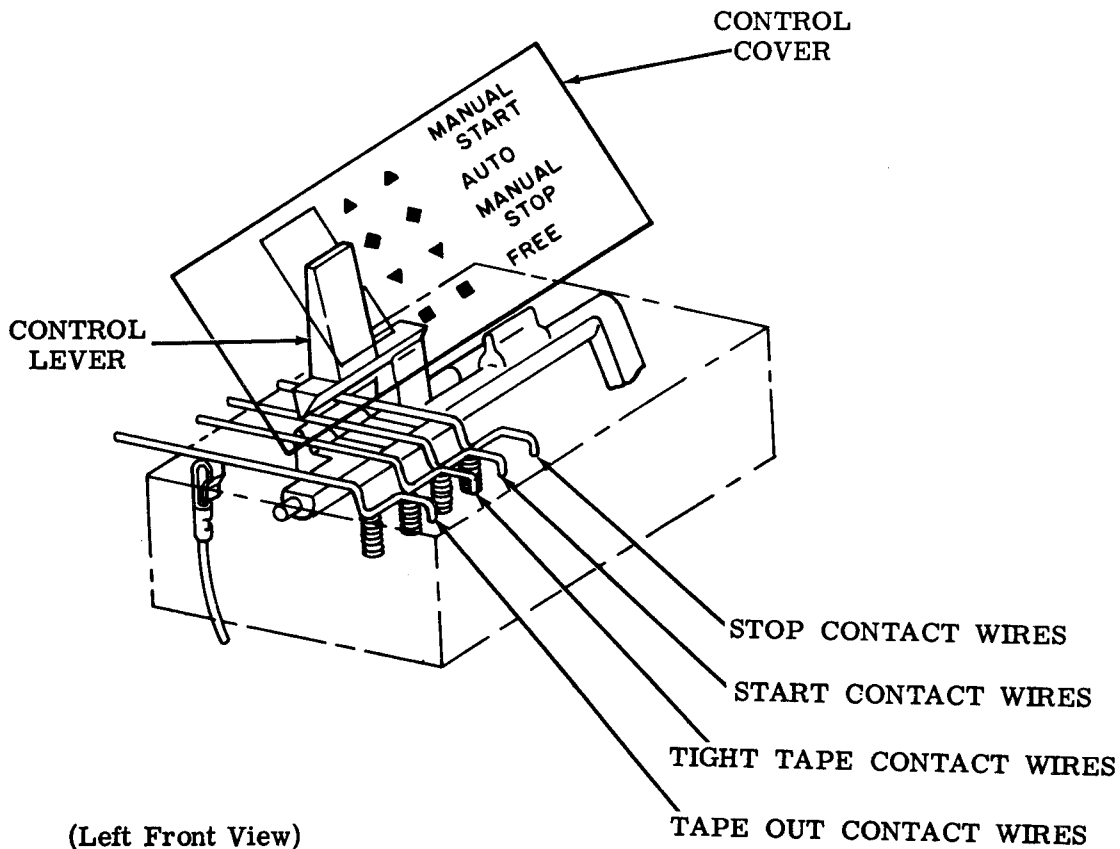

Figure 4 - Control Mechanism

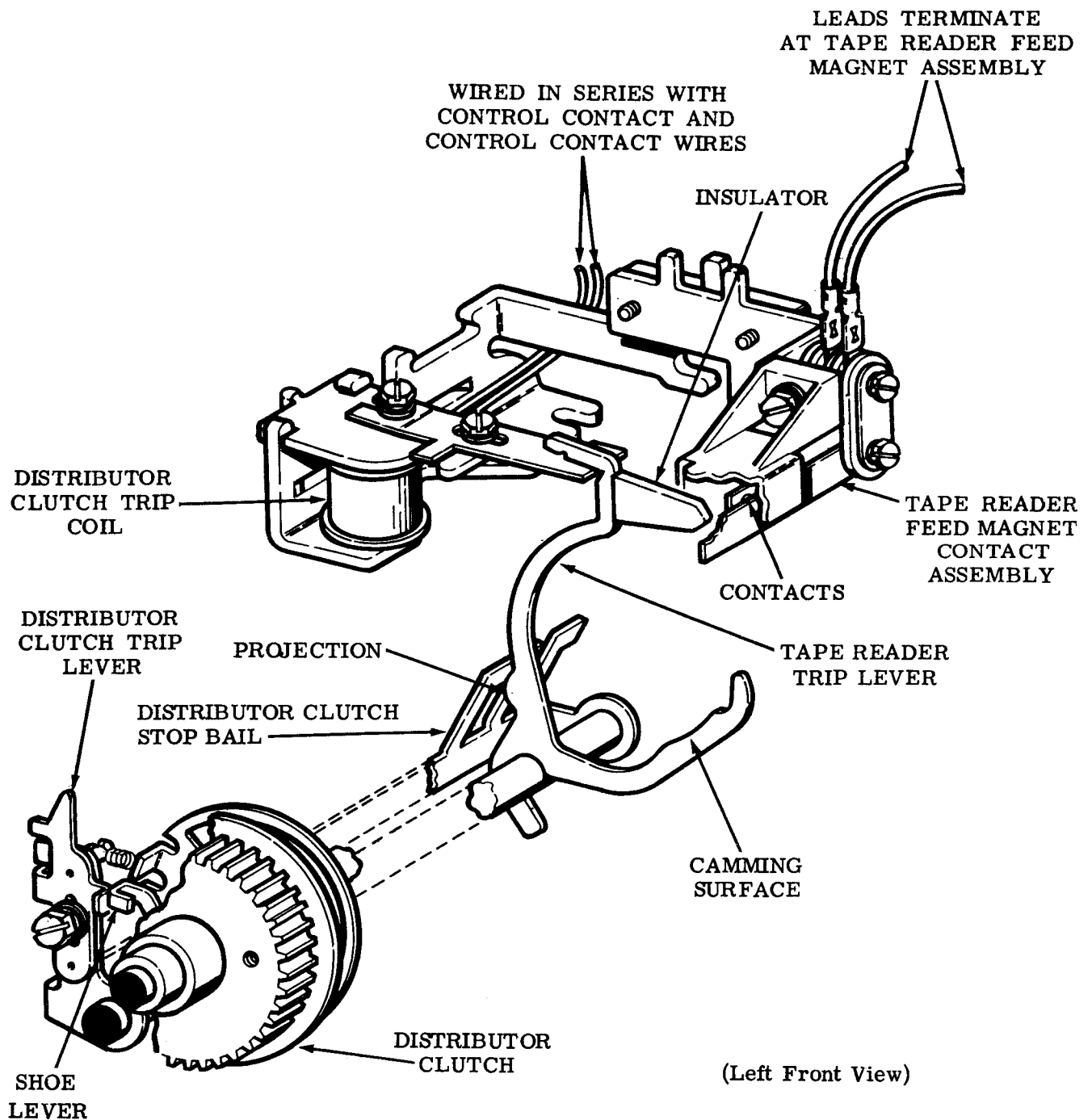

Figure 5 - Distributor Trip Mechanism

C. Distributor Trip Mechanism

3.08 When released the tape reader trip lever performs two functions; it closes the tape reader feed magnet contact assembly and trips the distributor clutch (Figure 5). The reader feed magnet assembly is closed by an insulator

on the back of the tape reader trip lever. In its travel, the tape reader trip lever rotates the distributor clutch stop bail by means of a projection. This motion is transferred to the distributor clutch trip lever which moves away from the shoe lever. The distributor clutch engages and the distributor cycle begins.

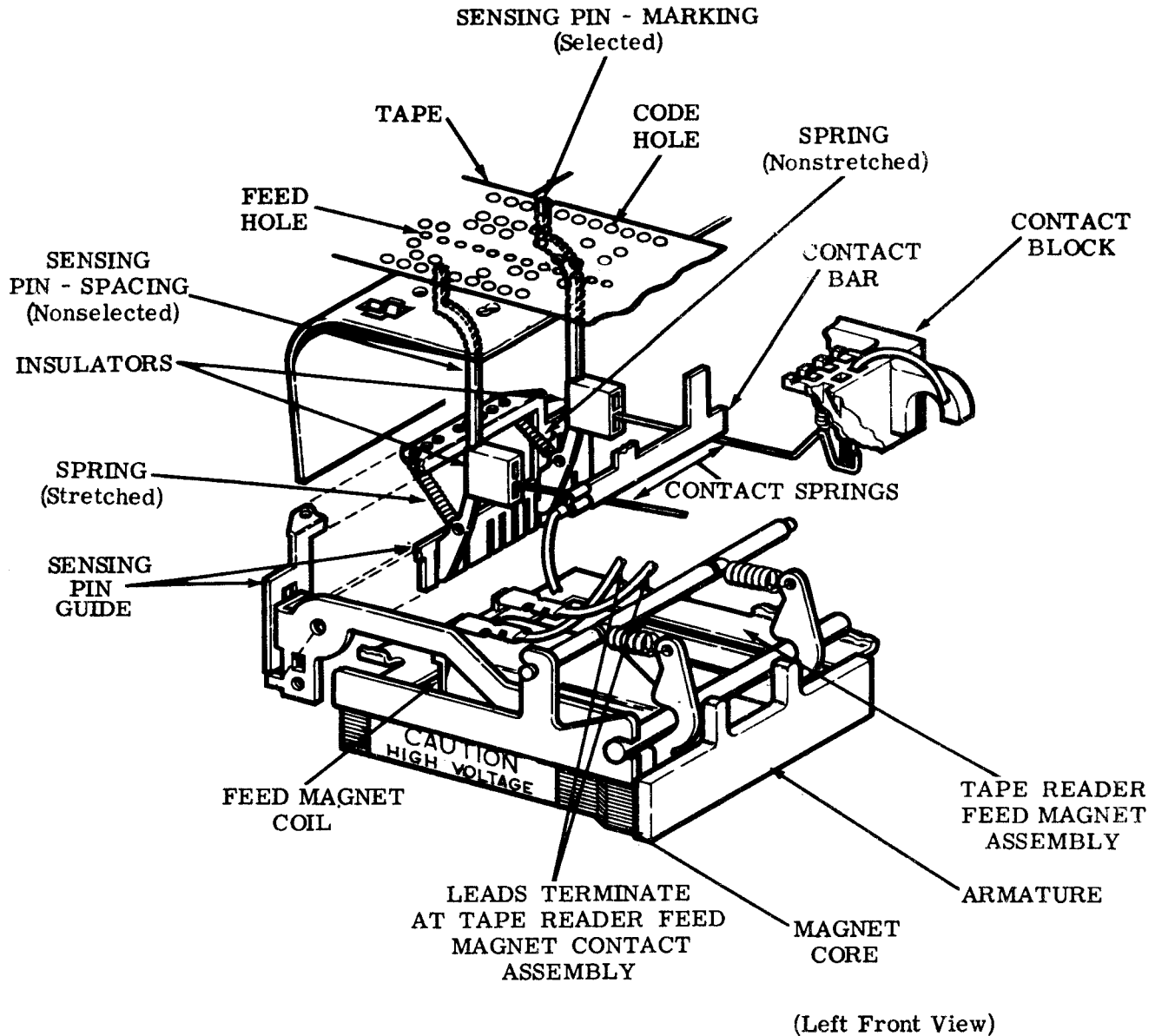

Figure 6 - Feed Magnet and Sensing Mechanism

D. Feed Magnet Mechanism

3.09 With the feed magnet contacts closed (Figure 5) the feed magnet in the reader mechanism is activated. The energized feed magnet coil attracts the armature (Figure 6). Rotating about its pivot the armature raises the armature extensions. Fastened to the ends of the armature extensions is a sensing pin guide.

E. Sensing Pin Guide Mechanism

3.10 In its upward travel the sensing pin guide carries with it eight spring-biased pins which sense the tape. Where a hole exists in the tape (marking) the sensing pin continues its upward travel and its associated spring remains unstretched. Where no hole exists in the tape (spacing) the sensing pin travel is blocked and its associated spring becomes stretched (Figure 6).

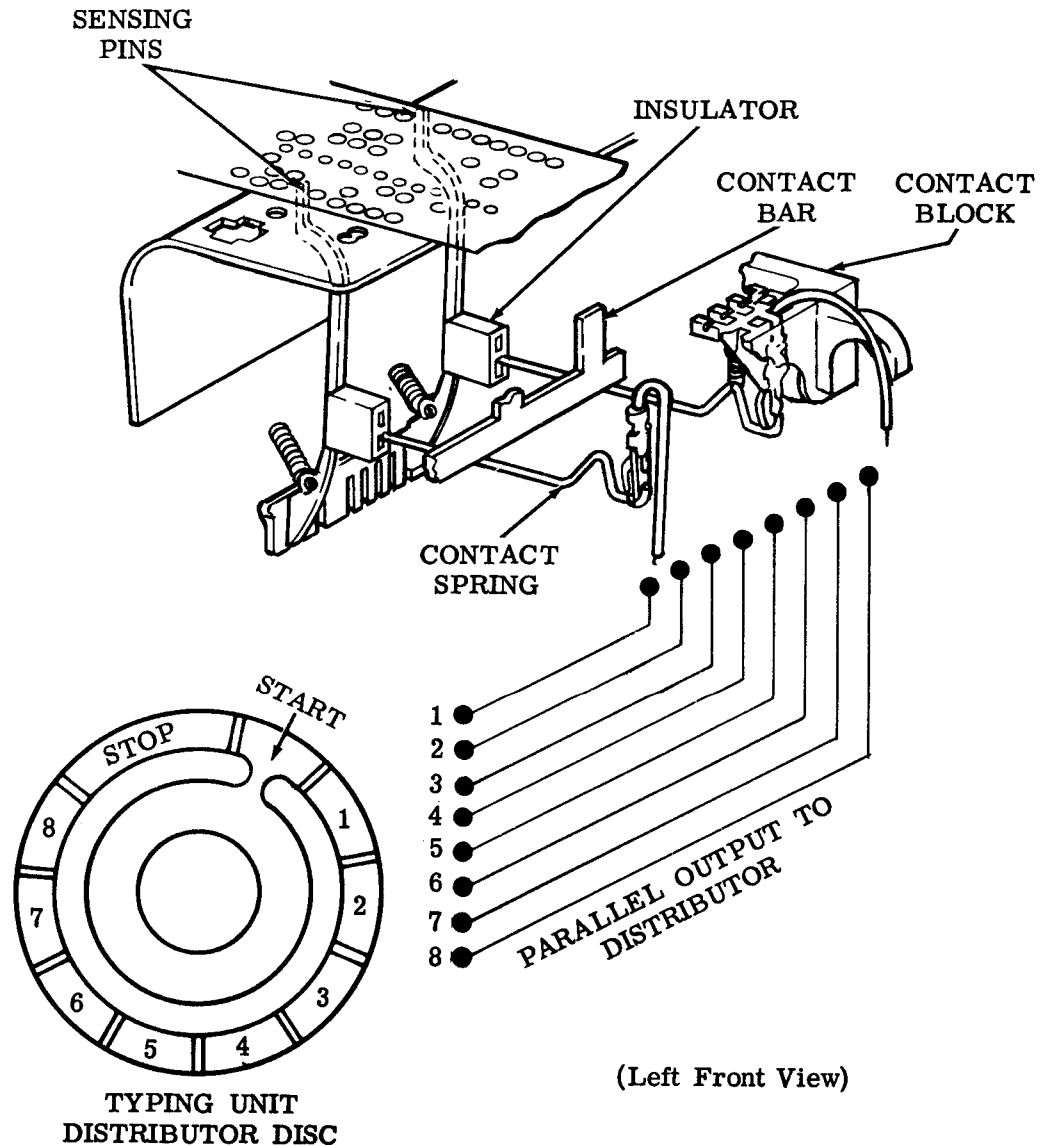
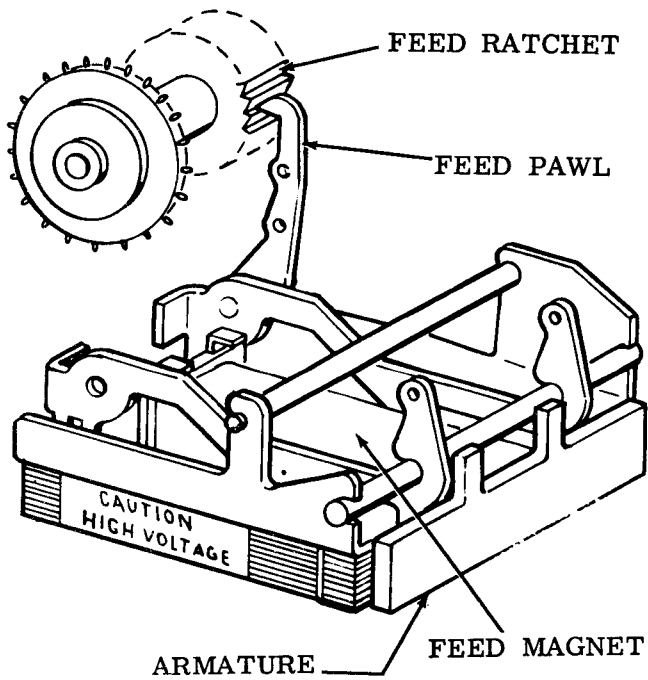

Figure 7 - Contact Block Mechanism

F. Contact Block Mechanism

3.11 There is an insulator attached to each sensing pin. The insulators hold eight contact springs in a down position, away from the contact bar (Figure 7). The eight contact springs are connected in parallel to corresponding segments on the distributor disc in the typing unit. If a sensing pin finds a hole in the tape (marking) it continues its upward travel. The

insulator attached to it also rises, allowing the contact spring to make contact with the contact bar (Figure 7). If a sensing pin does not find a hole in the tape (spacing) it remains in the down position, keeping the insulator down. This prevents the contact spring from making contact with the contact bar. Since all eight pins rise up simultaneously, the output going from the contact block to the distributor disc will be a parallel output.



(Left Front View)

Figure 8 - Feed Pawl Engagement

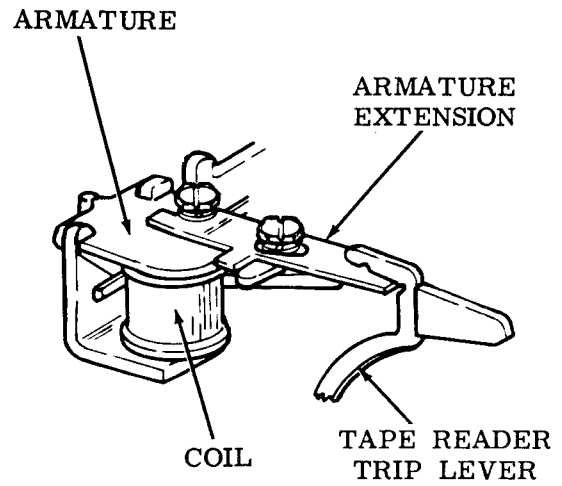

(Left Front View)

Figure 9 - Distributor Clutch Trip Coil

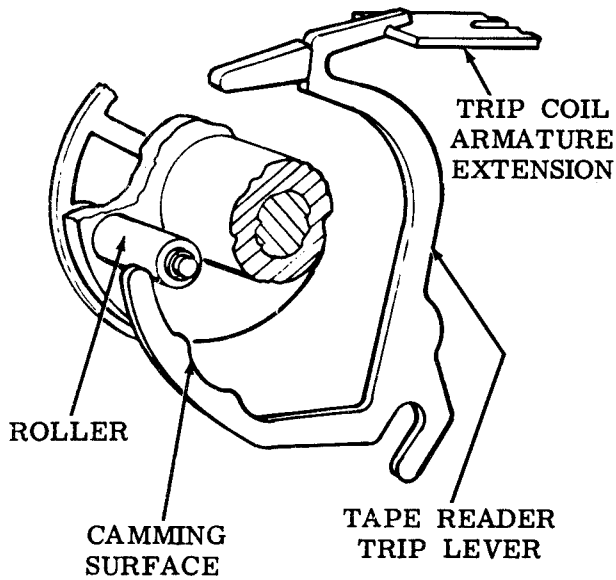

(Right Side View)

Figure 10 - Tape Reader Trip Lever

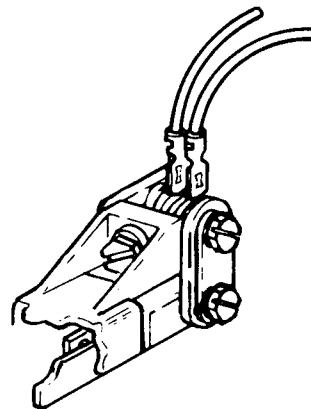

Figure 11 - Feed Magnet Contacts

G. Tape Feed Mechanism

3.12 The tape feeding cycle begins when the feed magnet attracts the armature as described in 3.09. The right armature extension has a feed pawl attached to it which engages a tooth on the feed ratchet when the armature extensions rise (Figure 8). Before the feed pawl can be pulled down to advance the feed wheel one character a series of steps take place as follows.

3.13 If the control lever is held in the START position, the distributor clutch trip coil will remain energized (Figure 9).

3.14 Near the beginning of the stop pulse the camming surface on the reader trip lever rides the camming roller on the distributor shaft and overtravels the trip coil armature (Figure 10).

3.15 The feed magnet contacts open momentarily causing the feed magnet in the reader mechanism to be de-energized (Figure 11).

3.16 With the feed magnet de-energized the armature extensions drop, withdrawing the sensing pin guide and the sensing pins (Figure 12).

3.17 The tape reader trip lever is reset in sufficient time so that the distributor clutch does not disengage. The tape reader trip lever, once reset, closes the feed magnet contacts by means of the insulator. The projection moves the distributor clutch stop bail which in turn keeps the distributor clutch trip lever away from the shoe lever, allowing the clutch to continue its rotation.

3.18 Tape feeding will occur at the same time that the sensing pins are withdrawn. As the armature extensions drop down the pawl advances the feed ratchet one tooth (Figure 13). Associated with the feed ratchet are also a detent lever and a blocking pawl.

3.19 The detent lever, with its circular surface engaging the feed ratchet teeth, holds the feed ratchet and the feed wheel in its correct position during sensing (Figure 13).

3.20 The blocking pawl, which rides a post on the feed pawl, is lowered into engagement with a feed ratchet tooth during the feed stroke. This is to prevent excessive overthrow of the feed wheel during feeding, without the use of a

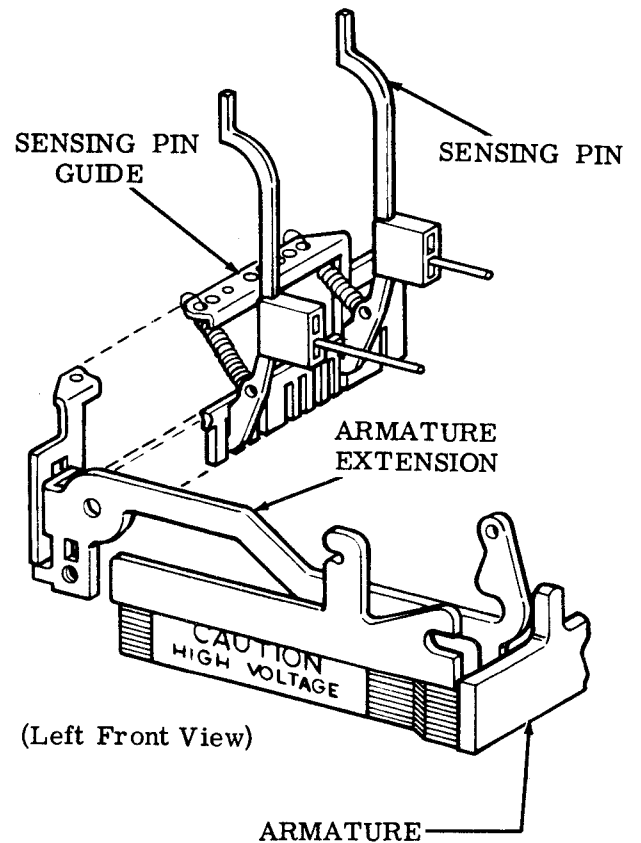

Figure 12 - Sensing Pin Guide

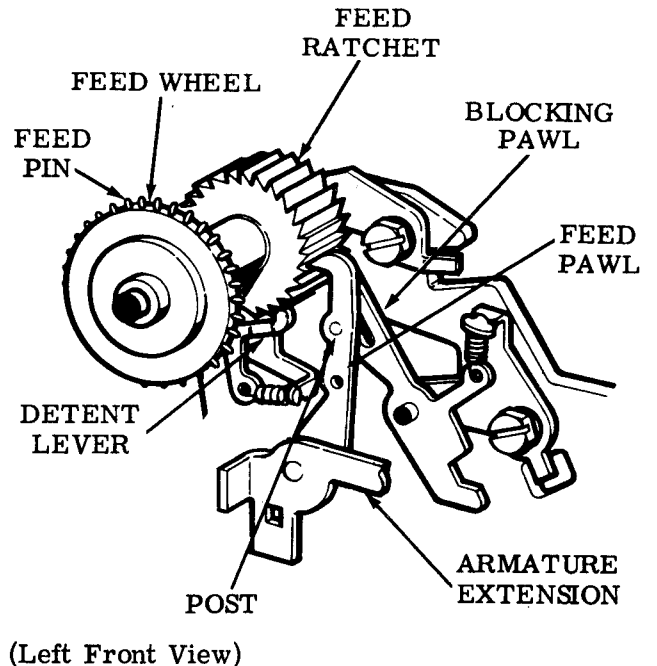

Figure 13 - Tape Feed Mechanism

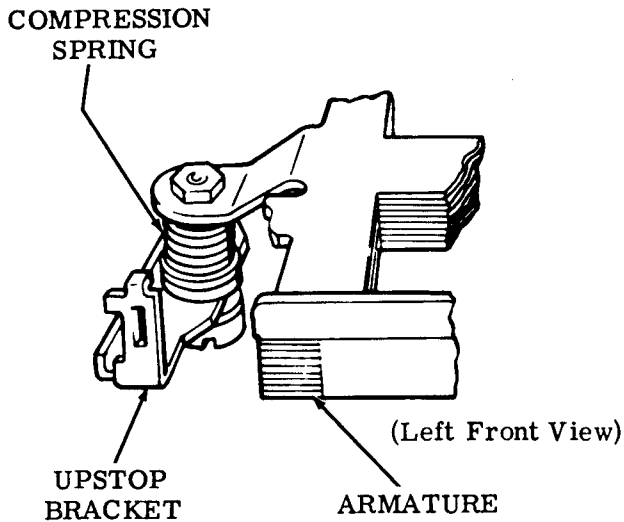

Figure 14 - Upstop Mechanism

heavy detent spring. It also prevents the pulling ahead of the tape, during sensing, by a tape winder, without the use of a heavy detent spring. During the upstroke of the armature extensions, the blocking pawl is rotated out of engagement with the tooth by the post on the feed pawl (Figure 13).

H. Upstop Mechanism

3.21 The armature is provided with a spring biased upstop which serves two purposes.

- (a) A portion of the energy during the end of the stroke is stored in a spring and returned to the armature on the downstroke to give a rapid release and acceleration.
- (b) A portion of the energy is dissipated through a resilient buffer to minimize noise and metallic clatter (Figure 14).

4. FEATURES

→ MANUAL READER

A. Freewheeling Mechanism (Figure 15)

4.01 The 33 tape reader is provided with a freewheeling feature which allows the feed wheel to rotate freely. When the control lever is moved to the FREE position, the extension on the control lever engages the blocking pawl and pivots it clockwise. Riding in a slot on the underside of the blocking pawl is a stud which connects to the feed pawl. As the blocking pawl

is pivoted clockwise by the control lever extension, the blocking pawl moves the feed pawl away from the feed ratchet. With the feed ratchet free, the feed wheel will also rotate freely.

B. Tight-Tape Mechanism (Figure 16)

4.02 This feature consists of a plastic tight-tape bail which snaps into the tape lid. The tight-tape bail serves to turn the tape reader OFF when the moving tape becomes taut. The tight-tape bail has an extension on it which projects through the top plate. This extension rides on a spring biased tight-tape lever. If the tape in the tape reader becomes taut, the bail will be lifted. The bail extension will rotate, causing the tight-tape lever to rotate also. In its pivoting motion the tight-tape lever will lift the tight-tape contact wires away from the contact terminal, breaking the current path. With the circuit broken the tape reader stops.

C. Tape-Out Mechanism (Figure 17)

4.03 The tape reader is equipped with a tape-out feature which will stop the tape reader when the tape runs out. A tape-out pin protrudes above the surface of the top plate. During tape sensing the tape-out pin is kept depressed by the moving tape. When the tape runs out, the spring biased tape-out pin moves fully up. An

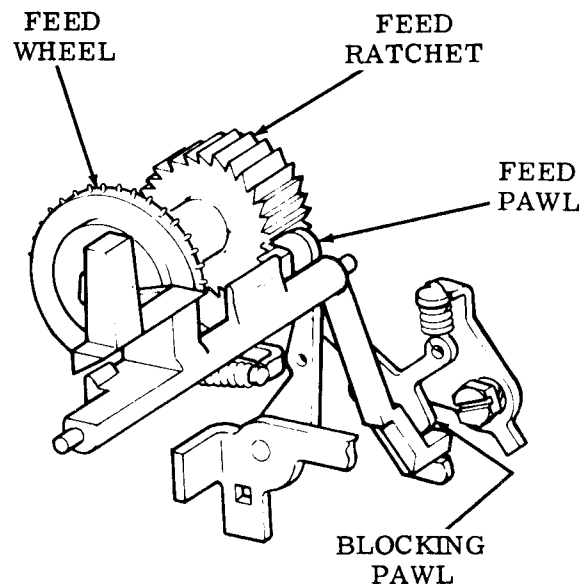

(Left Front View)

Figure 15 - Freewheeling Mechanism

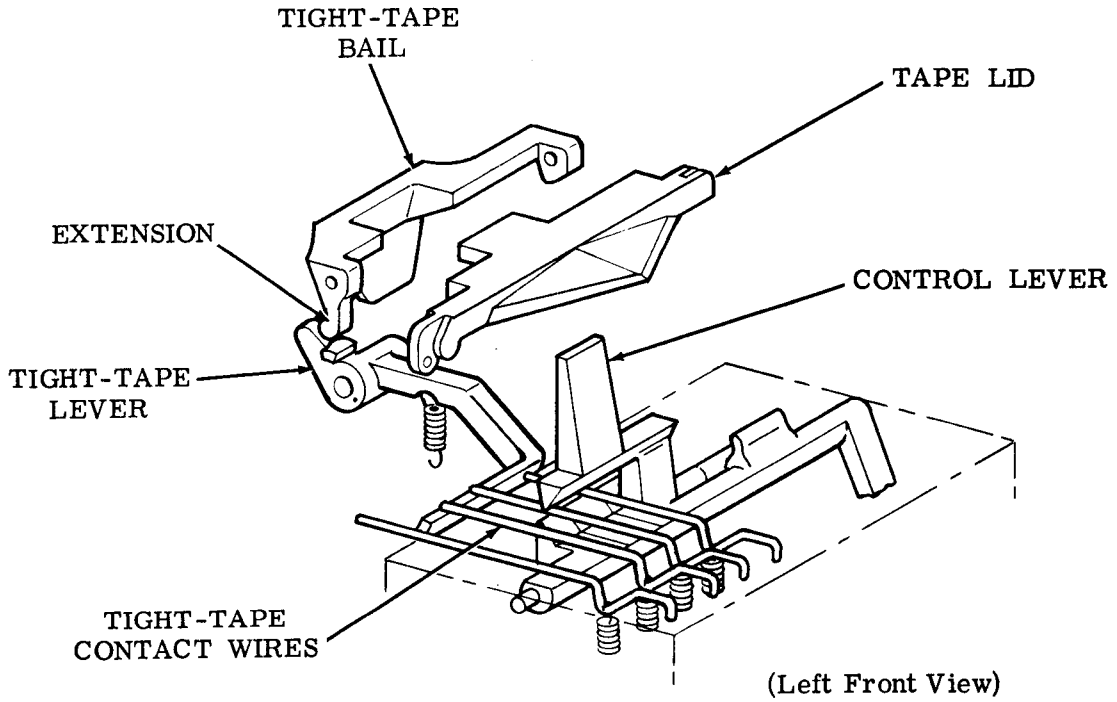

Figure 16 - Tight-Tape Mechanism

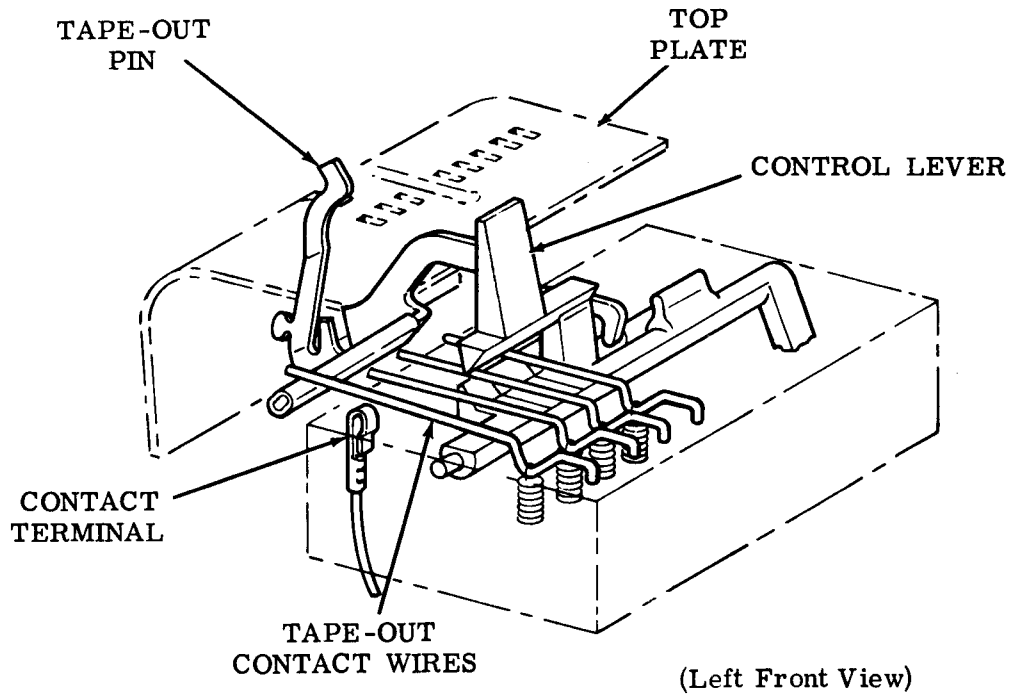

Figure 17 - Tape-Out Mechanism

insulated extension on the tape-out pin lifts the tape-out contact wires away from the contact terminal. This breaks the current path and the tape reader stops.

AUTOMATIC CONTROL FEATURES

4.04 The automatic control features allow the tape reader to be started or stopped either manually or automatically. This is accomplished by means of additional contacts, a relay, and wiring. There are other contacts in the typing unit function area and, for sprocket feed typing units, in the form out mechanism, which are related with the tape reader automatic features.

A. Local Start (Figure 18)

4.05 When the control lever is placed in the MANUAL START position the following events take place:

- (a) The start contact wires close momentarily.
- (b) After closing momentarily the start contact wires are opened due to the detent action of the control lever.

- (c) The momentary closing of the start contact wires energizes the relay and two normally open contacts associated with the relay.
- (d) The first relay contact closes a holding circuit.
- (e) The second relay contact — if there is tape in the tape reader and the tape-out contact is closed — closes the circuit to the distributor clutch. The distributor clutch will then be tripped as explained in 3.08.

B. Remote Start (Figure 19)

4.06 When the control lever is placed in the AUTO position, the start contact is open and the stop contact is closed. The tape reader will respond to a remote reader start signal and turn ON automatically. The remote signal will close a contact in the typing unit function area and complete an electrical path to the distributor area.

C. Reader Stop

4.07 When the control lever is placed in the MANUAL STOP position, the stop contact wires are momentarily opened, de-energizing

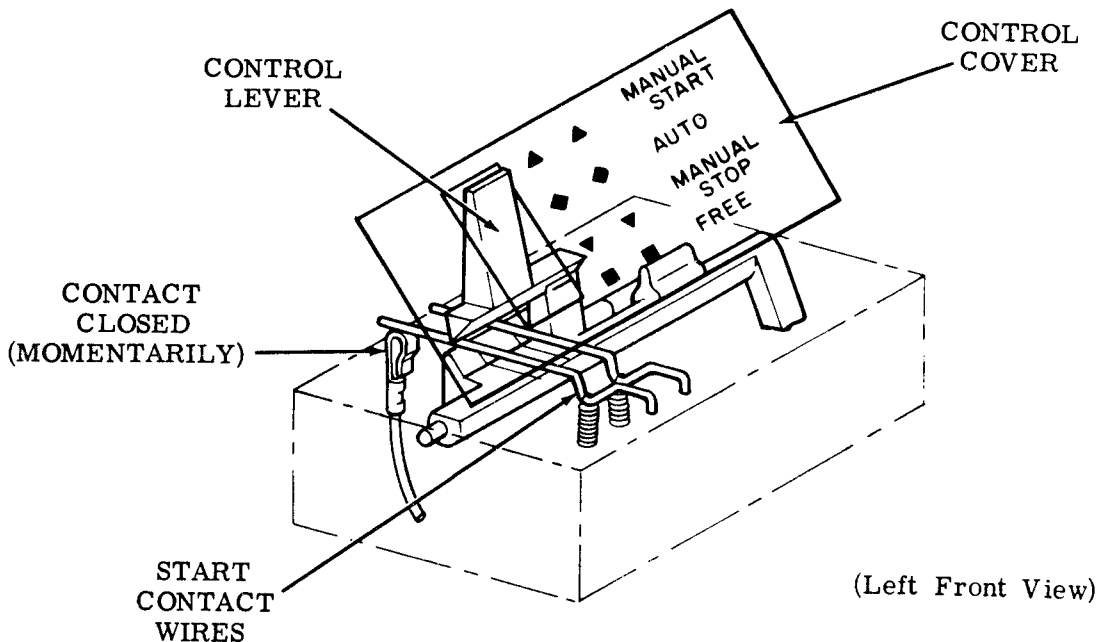

Figure 18 - MANUAL START Position

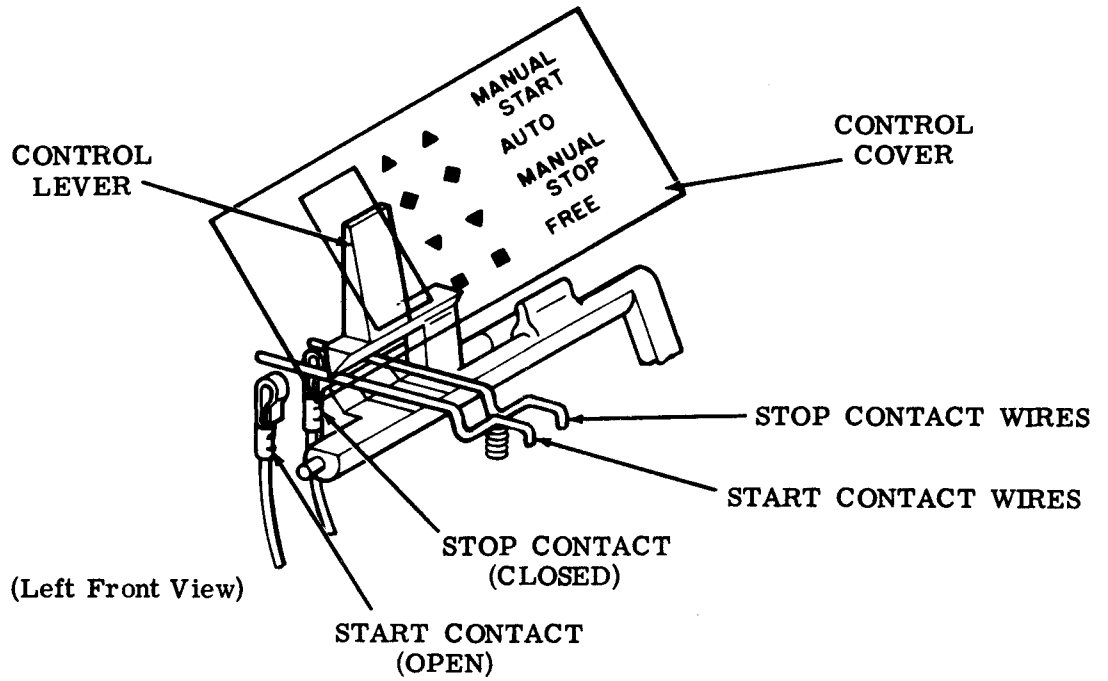

Figure 19 - Automatic Start Position

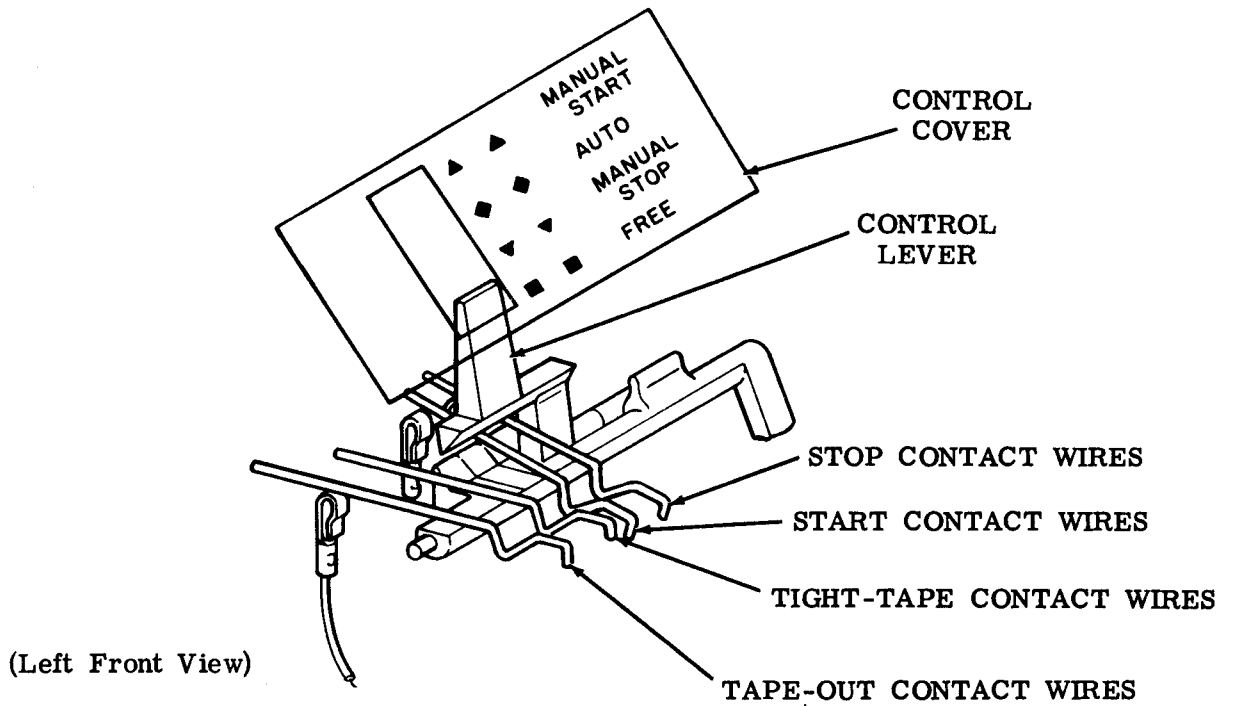

Figure 20 - Control Lever in FREE Position

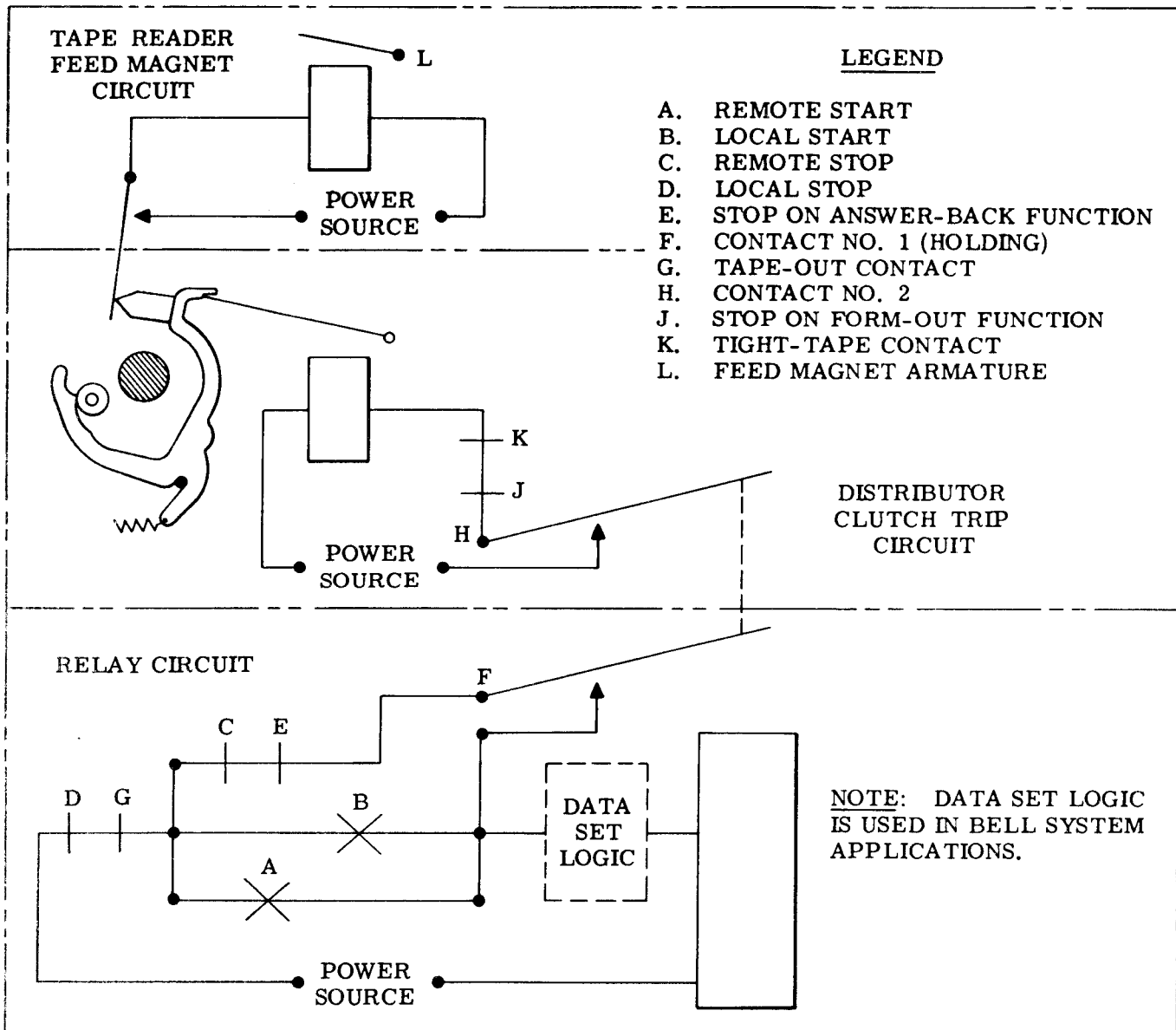

Figure 21 - Automatic Reader Control Schematic

the relay and opening two relay contacts. One of these contacts opens the reader trip magnet circuit. The trip magnet de-energizes causing the tape reader to stop.

Alternate Reader Stop

4.08 The automatic tape reader can be stopped either permanently or temporarily. When the reader is stopped permanently it cannot be started again automatically but must be started manually. When temporarily stopped, the reader can be started again either automatically or manually.

Permanent Stop

4.09 Besides the stop contact wires mentioned in 4.07, the following are normally closed contacts wired in series with the relay in the power pack:

- (a) Tape-out contact wires
- (b) Tape reader OFF function box contact
- (c) WRU function box contact

When one of these contacts is momentarily opened, the relay is de-energized, opening two relay contacts. One of these relay contacts

opens the reader trip magnet circuit. The trip magnet de-energizes causing the reader to stop permanently.

Temporary Stop

4.10 The following normally closed contact wires are wired in series with the reader trip magnet:

- (a) Form-out function box contact
- (b) Tight-tape contact wires

When one of these contacts is opened the trip magnet is de-energized stopping the tape reader temporarily.

D. FREE Position (Figure 20)

4.11 When the control lever is placed in the FREE position the start and stop contacts are open. The tape reader will not respond to a remote reader start signal.

33 TAPE READER

LUBRICATION

CONTENTS	PAGE
1. GENERAL	1
2. BASIC UNIT	2
Armature shaft	4
Clutch trip area	6
Control mechanism	5
Distributor clutch trip magnet	7
Feed pawl mechanism	5
Feed wheel	4
Reader feed magnet contact	7
Reader trip lever	8
Tape lid mechanism	6
Tape reader	2
Tape reader mechanism	3
Tight tape mechanism	4

to make sure no areas have been missed. Thereafter, lubricate the tape reader at regular intervals as indicated below:

<u>Operating Speed</u> (Words per Minute)	<u>Lubrication</u> <u>Interval</u>
100	500 hours* or 6 months**

*Station Set operating hours.
 **Whichever comes first.

1.05 The textual instructions that accompany the line drawings consist of abbreviated directions, specific lubrication points, and parts affected. The meanings of the abbreviated directions (symbols) are given below:

<u>Symbol</u>	<u>Meaning</u>
D	Keep dry -- no lubricant permitted.
G	Apply thin coat of KS7471 grease.
L	Apply thin coat of Lubriplate 105 (2 oz tube TP108805).
O	Oil (KS7470 oil).

1. GENERAL

1.01 This section contains lubrication requirements for the tape reader. It is reissued to provide exclusive and updated 33 tape reader information. Since this is a general revision, marginal arrows used to indicate changes have been omitted.

1.02 The general lubrication areas are illustrated by photographs. The specific points to receive lubricant are indicated on line drawings with appropriate textual instructions. Line drawings and textual instructions follow each photograph and are keyed to the photograph by paragraph numbers.

1.03 Thoroughly lubricate the tape reader, but avoid over lubrication that might permit the lubricant to drip or be thrown onto adjacent parts. Saturate all felt washers.

1.04 Lubricate the tape reader before placing it into service or prior to storage. After a short period of service, relubricate it

1.06 References to left, right, front, or rear, etc, consider the tape reader to be viewed from a position where the feed wheel faces up and the lid latch is to the viewer's right. Orientation references in the clutch trip area consider the armature extension to be facing up with the contact bracket pry points located to the viewer's right.

CAUTION: DO NOT USE ALCOHOL, MINERAL SPIRITS, OR OTHER SOLVENTS TO CLEAN PLASTIC PARTS OR PARTS WITH PROTECTIVE, DECORATIVE FINISHES. NORMALLY, A SOFT, DRY CLOTH SHOULD BE USED TO REMOVE DUST, OIL, GREASE

OR OTHERWISE CLEAN PARTS OR SUBASSEMBLIES. A SOFT CLOTH DAMPENED WITH SOAP OR MILD DETERGENT MAY BE USED. RINSE WITH A SOFT, DAMPCLOTH AND BUFF WITH A SOFT, DRY CLOTH.

1.07 Materials needed for lubrication are listed in Section 570-005-800TC.

1.08 For disassembly and reassembly information, refer to Section 574-124-702.

CAUTION: REMOVE ALL ELECTRICAL POWER FROM UNIT BEFORE LUBRICATING OR DISASSEMBLING COMPONENTS.

2. BASIC UNIT

2.01 Tape Reader

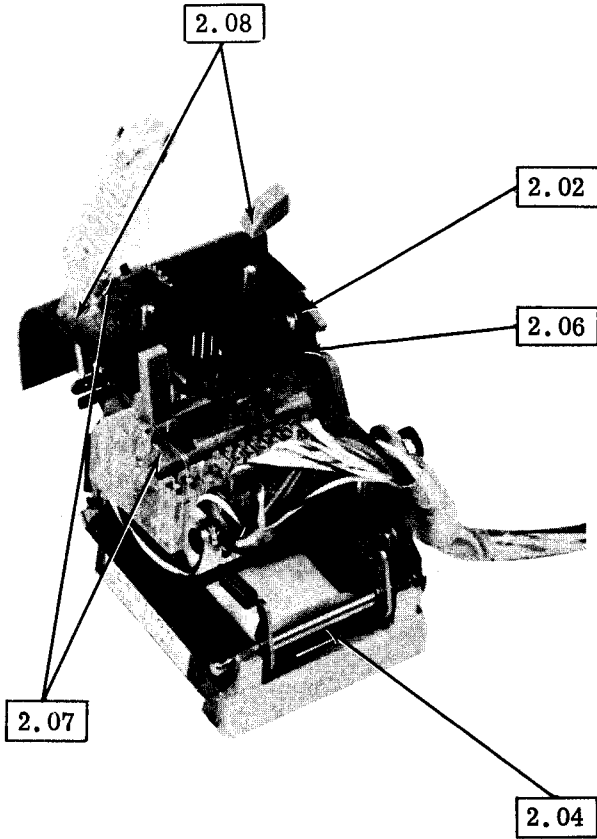

(Left Front View)

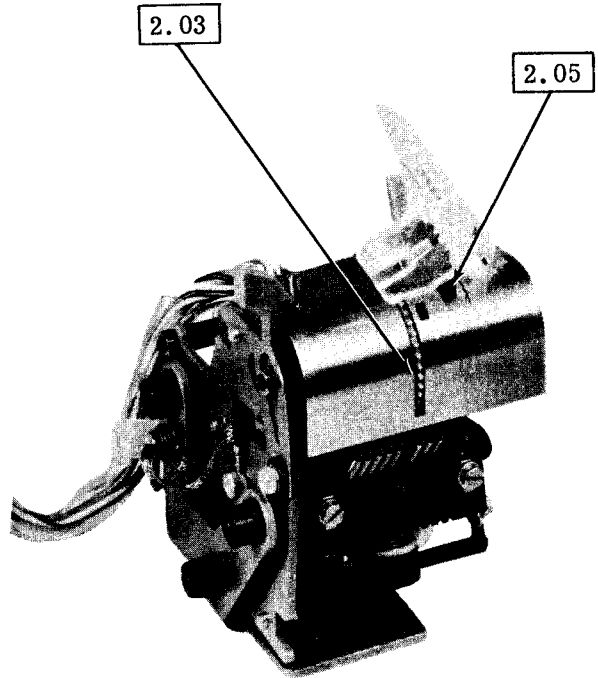

(Right Rear View)

2.02 Tape Reader Mechanism

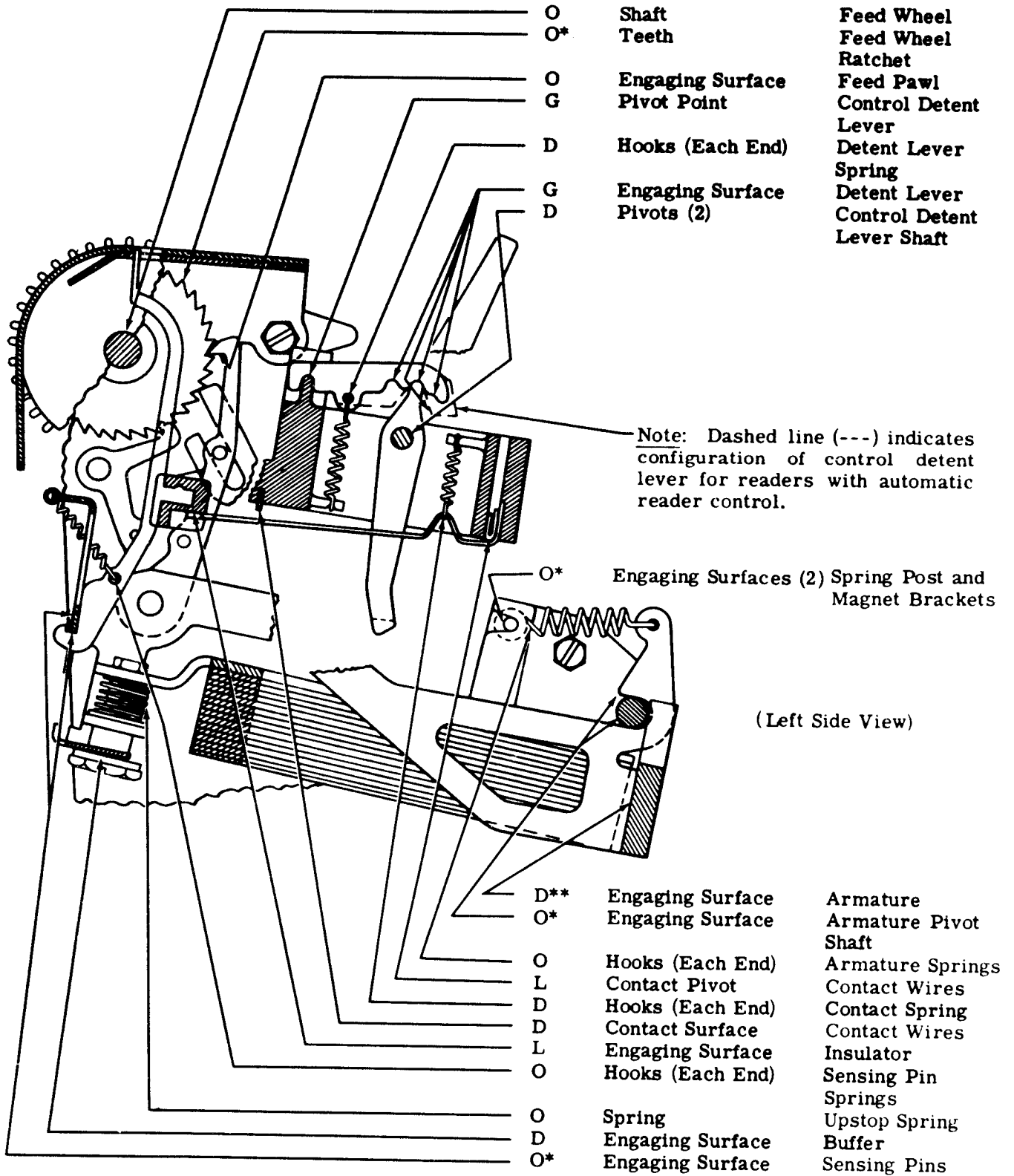

*At 1500 hour lubrication intervals, apply with a coat of thoroughly mixed 50 percent KS7470 oil and 50 percent KS7471 grease.

**Some oil leakage on this surface is permissible.

2.03 Feed Wheel

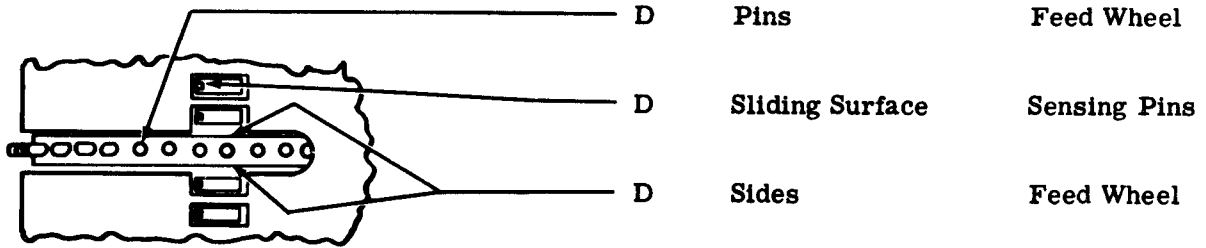

(Top View)

2.04 Armature Shaft

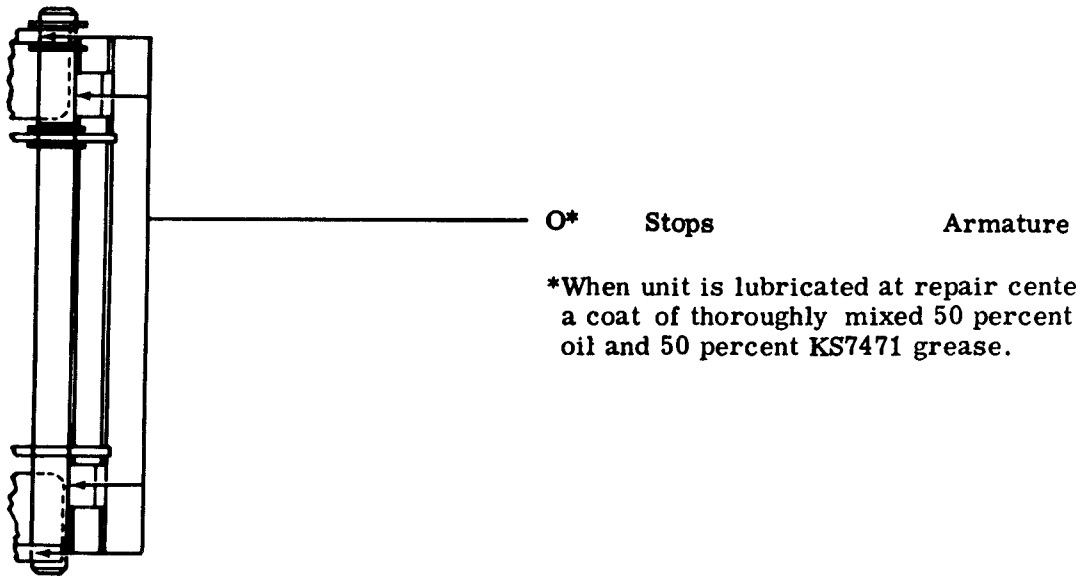

*When unit is lubricated at repair center, apply a coat of thoroughly mixed 50 percent KS7470 oil and 50 percent KS7471 grease.

(Top View)

2.05 Tight Tape Mechanism

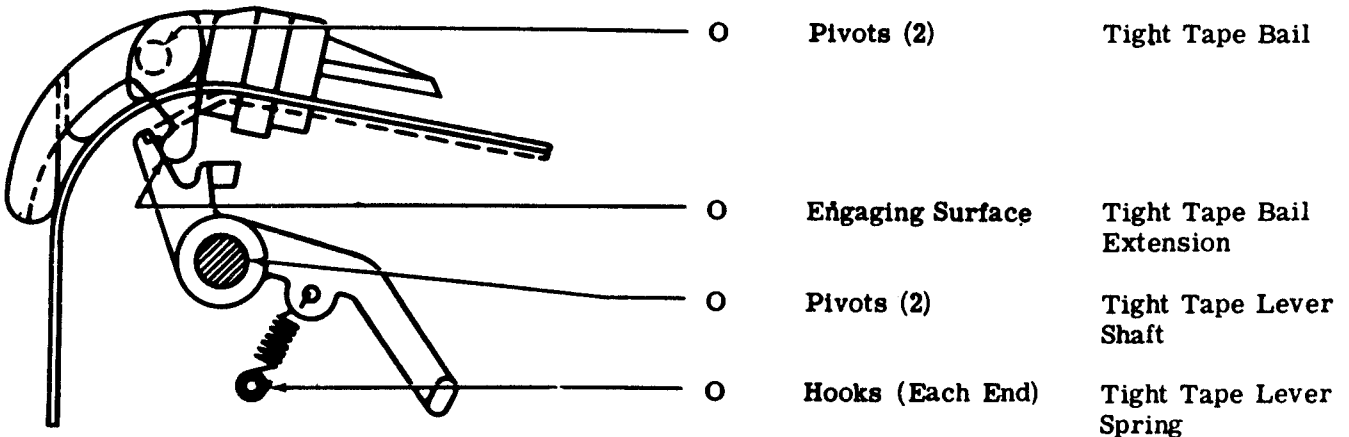

(Left Side View)

2.06 Feed Pawl Mechanism

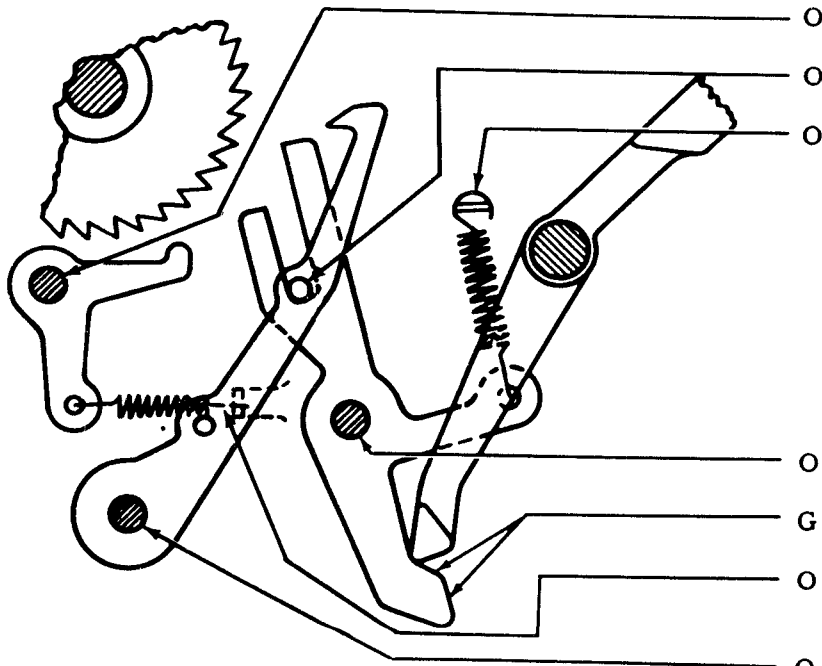

(Left Side View)

- O Pivot Detent Lever Shaft
- O Pivot Feed Pawl Stud
- O Hooks (Each End) Blocking Pawl Spring
- O Pivot Blocking Pawl
- G Engaging Surface Blocking Pawl
- O Hooks (Each End) Detent Lever Spring
- O Pivot Feed Pawl

2.07 Control Mechanism

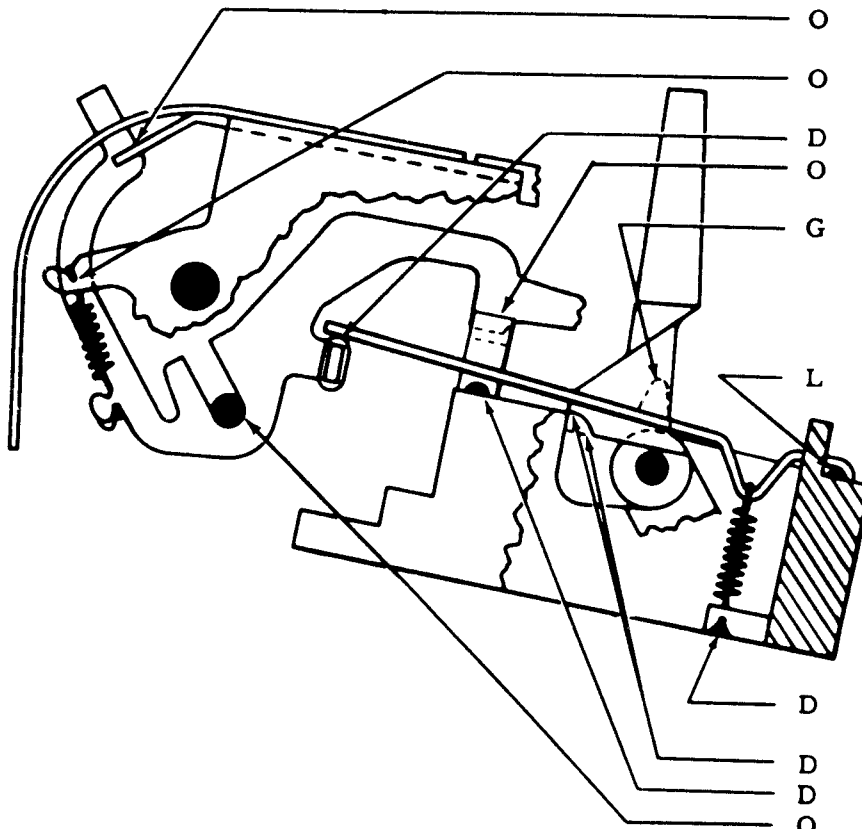

(Left Side View)

- O Sliding Surface Tape-Out Pin Guide
- O Hooks (Each End) Tape-Out Pin Spring
- D Engaging Surface Insulator
- O Sliding Surface Tape-Out Lever Guide
- G Camming Surface Tape-Out Lever Cam
- L Pivot Contact Wire
- D Hooks (Each End) Contact Wire Springs
- D Camming Surface Control Lever Terminal
- D Contact Surface
- O Pivot Tape-Out Lever

2.08 Tape Lid Mechanism

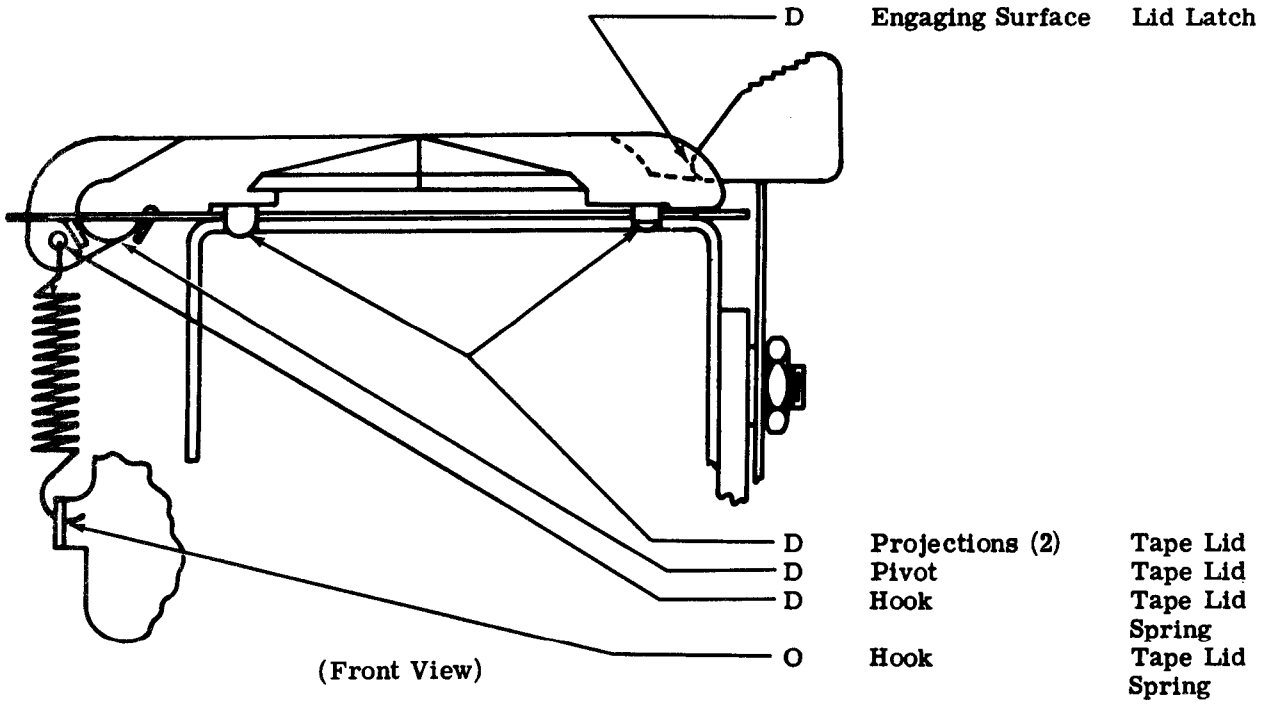

2.09 Clutch Trip Area

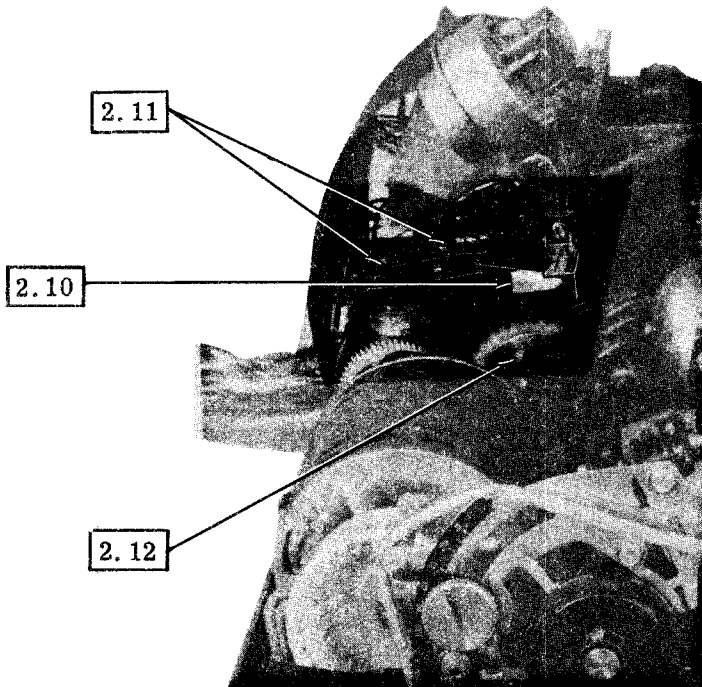

(Left Side View)

2.10 Reader Feed Magnet Contact

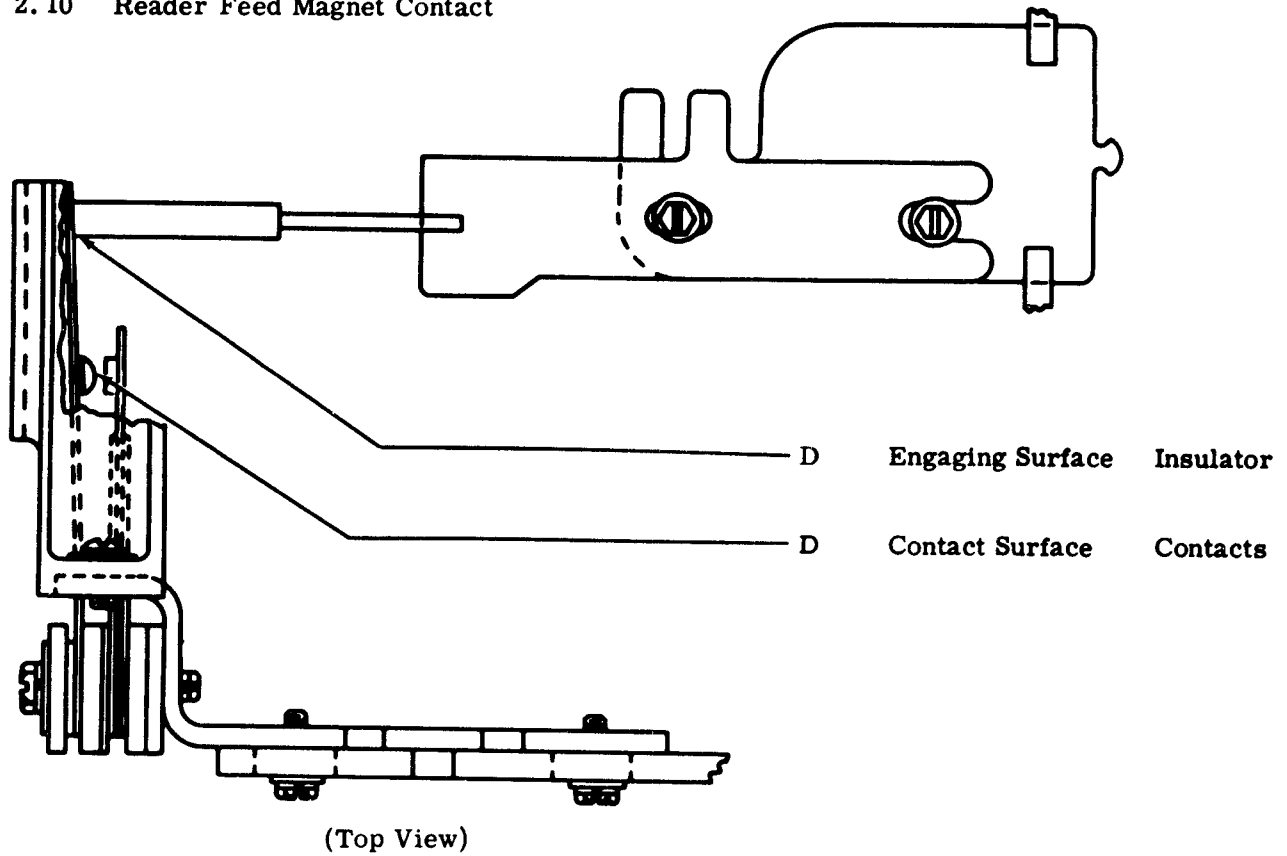

2.11 Distributor Clutch Trip Magnet

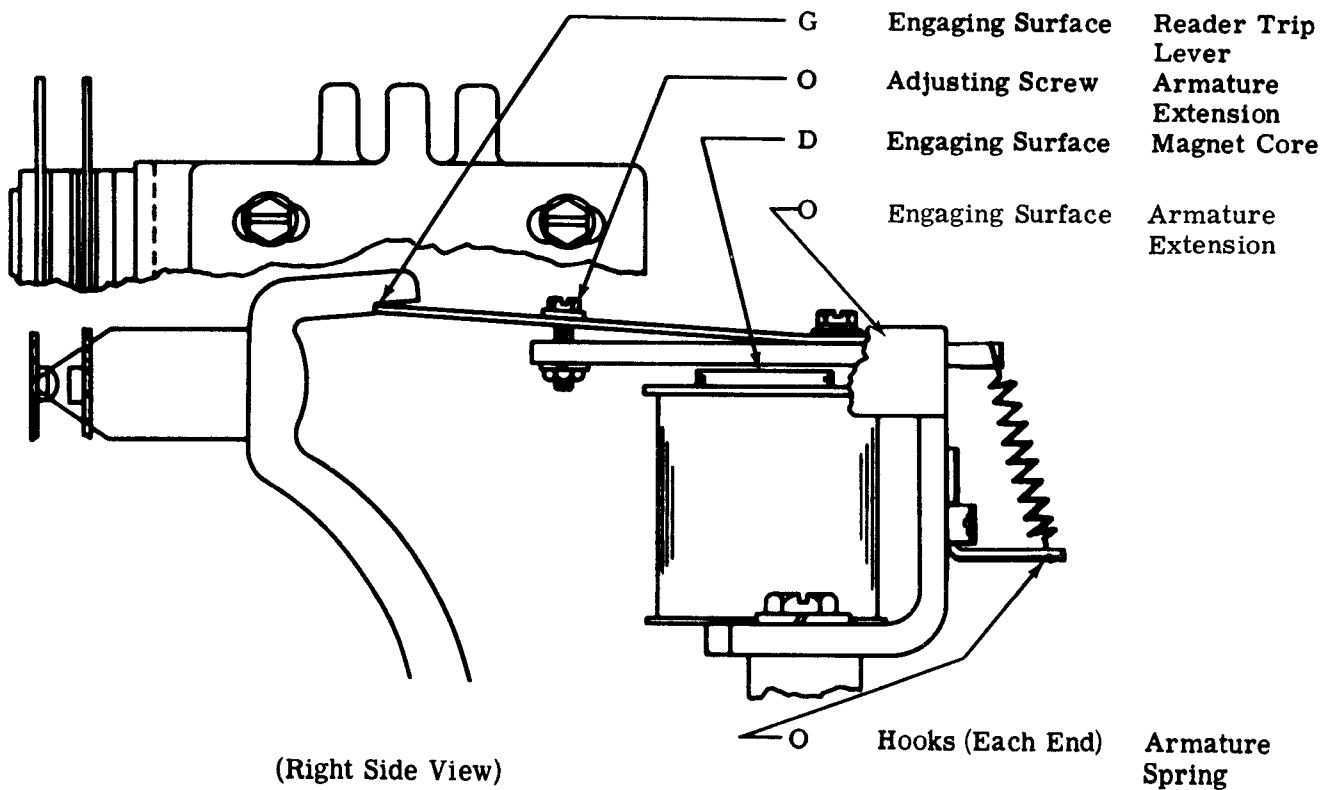

2.12 Reader Trip Lever

(Remove answer-back drum.)

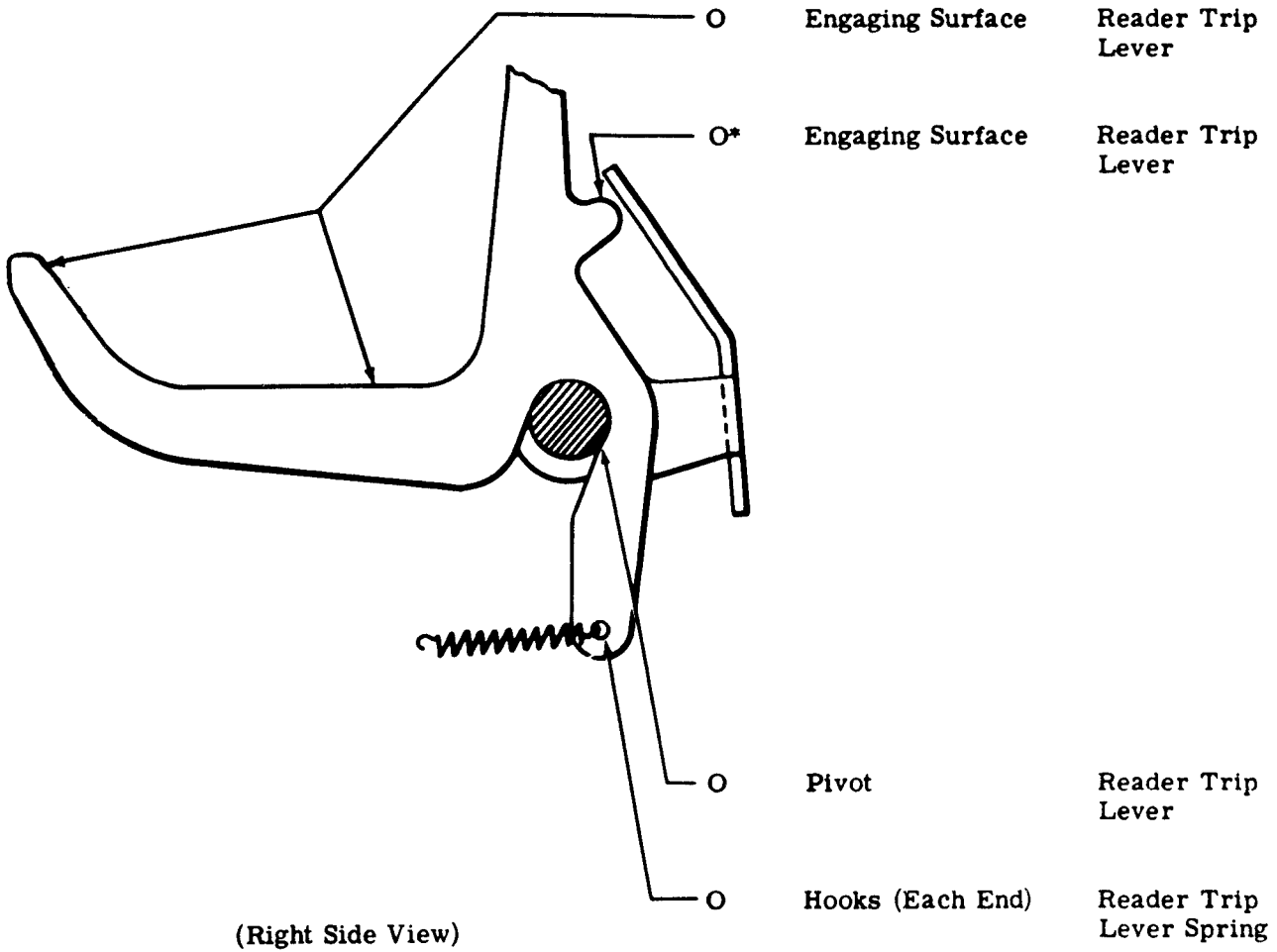

(Replace answer-back drum.)

*At 1500 hour lubrication intervals, apply a coat of thoroughly mixed 50 percent KS7470 oil and 50 percent KS7471 grease.

33 TAPE READER

DISASSEMBLY AND REASSEMBLY

CONTENTS	PAGE
1. GENERAL	1
2. DISASSEMBLY AND REASSEMBLY . .	1
SENSING PIN ASSEMBLY	1
FEED MAGNET ASSEMBLY	1
FEED WHEEL AND TOP PLATE ASSEMBLY	2
TAPE READER FEED MAGNET CONTACT	2
TAPE READER CLUTCH TRIP MAGNET ASSEMBLY	3

1. GENERAL

1.01 This section is reissued to incorporate recent engineering changes and to present disassembly and reassembly information exclusively for 33 tape readers. Since this is a general revision, marginal arrows, used to indicate changes, have been omitted.

1.02 References to left, right, front, rear, etc, consider the tape reader to be viewed from a position where the feed wheel faces up and the lid latch is to the viewer's right.

1.03 Disassembly, as outlined in this section, covers the procedure for removing the principle subassemblies which make up the unit. If further disassembly is required, refer to the appropriate illustrated parts section which shows detailed arrangements of parts. Where it will help in determining location, the numbers of the parts are given in the instructions.

1.04 All tools used to remove the various assemblies referred to in this section can be found in the standard tool section 570-005-800TC.

1.05 All damaged, worn, or distorted parts should be replaced if encountered in the disassembly and reassembly procedures.

2. DISASSEMBLY AND REASSEMBLY

Note: For information concerning the proper procedure to remove the tape reader and associated cable assemblies from the set, refer to appropriate set disassembly and reassembly section.

SENSING PIN ASSEMBLY

2.01 To remove the sensing pin assembly (Figure 2), proceed as follows.

(a) Remove the two TP151152 mounting screws, TP110743 lockwashers, and TP104807 flat washers which mount the TP183035 sensing pin guide.

(b) Remove sensing pin assembly.

(c) To replace sensing pin assembly, reverse procedure used to remove it.

FEED MAGNET ASSEMBLY

2.02 To remove the feed magnet assembly (Figure 1), proceed as follows.

(a) Remove contact block assembly.

(b) Remove sensing pin assembly.

(c) Unhook the TP90517 detent lever spring from the TP183023 detent bracket.

(d) Unhook the TP114107 blocking pawl spring from the TP183020 blocking pawl bracket.

(e) Remove the TP151152 magnet bracket mounting screw, the TP110743 lock-washer, and the TP104807 washer. Then, remove the two TP181241 magnet bracket mounting screws.

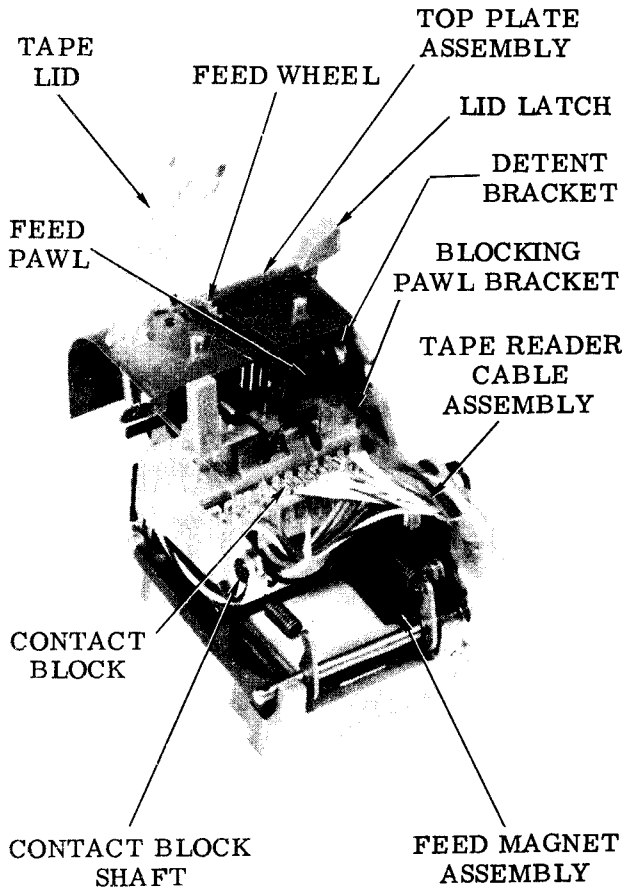

(Left Front View)

Figure 1 - Tape Reader (Without Cover)

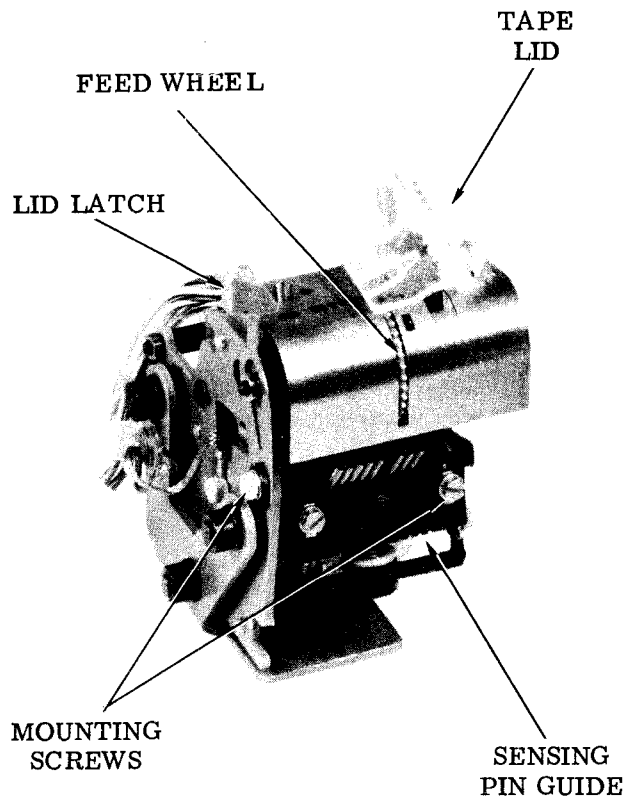

(Right Rear View)

Figure 2 - Tape Reader (Without Cover)

- (f) Slide the TP183011 feed pawl stud out of engagement with the TP183016 blocking pawl.
- (g) Remove feed magnet assembly.
- (h) To replace feed magnet assembly, reverse procedure used to remove it.

FEED WHEEL AND TOP PLATE ASSEMBLY

2.03 To remove feed wheel and top plate assembly (Figure 1), proceed as follows.

- (a) Remove contact block and cable assembly.
- (b) Remove sensing pin assembly.

- (c) Remove the TP182139 feed magnet assembly.
- (d) Unlatch the TP183032 tape lid.
- (e) Remove the TP181241 detent bracket mounting screw and TP3598 feed wheel shaft nut and TP124177 lockwasher.
- (f) Remove feed wheel and top plate assembly.
- (g) To replace feed wheel and top plate assembly, reverse procedure used to remove it.

TAPE READER FEED MAGNET CONTACT

2.04 To remove the tape reader feed magnet contact (Figure 3), proceed as follows.

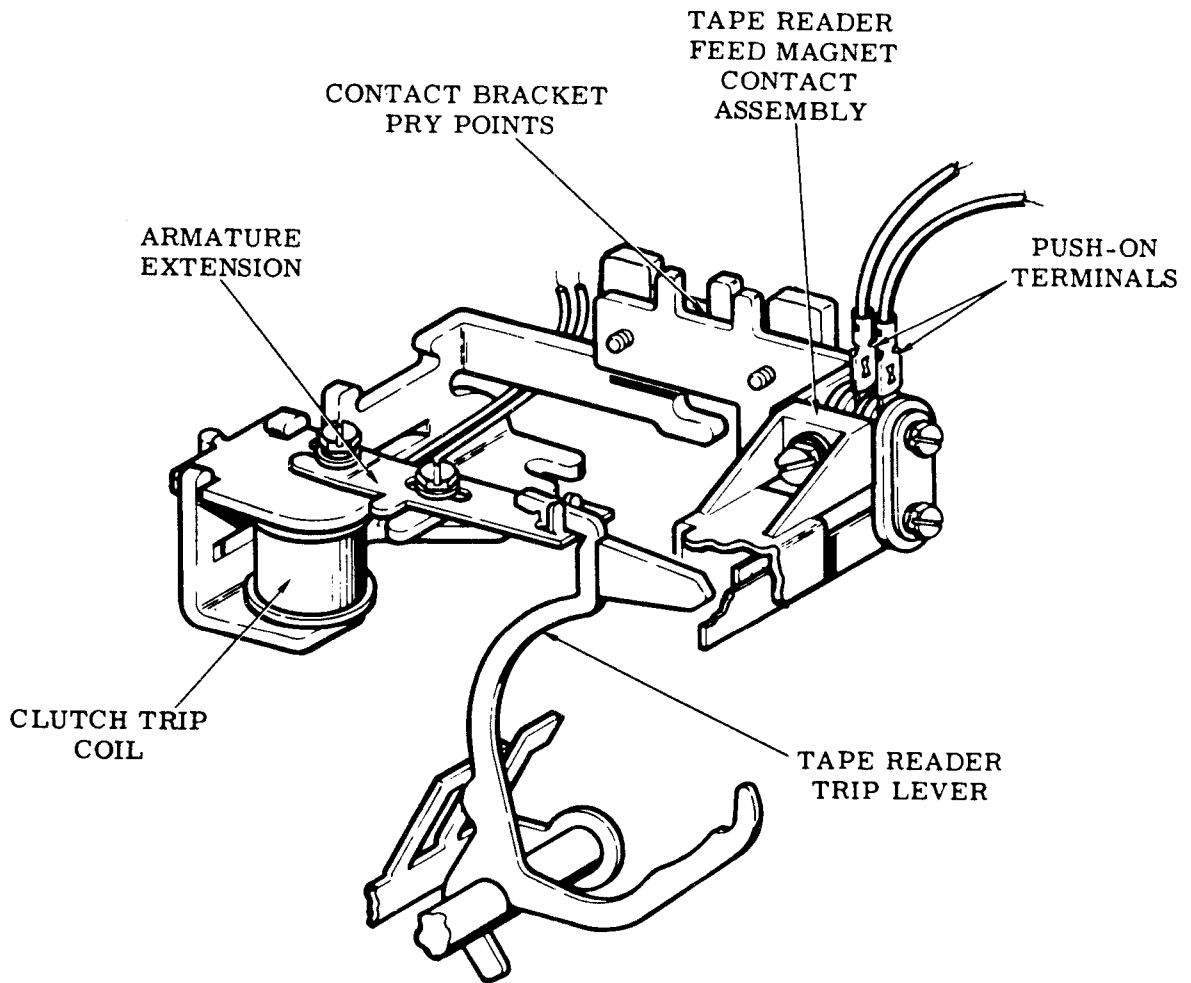

Figure 3 - Clutch Trip Magnet Assembly

- (a) Remove the two push-on TP182726 terminals of the tape reader cable.
- (b) Remove the two TP152893 tape reader feed magnet mounting screws, two TP104807 flat washers, and two TP110743 lockwashers.
- (c) Remove the tape reader feed magnet contact assembly.
- (d) To replace the tape reader feed magnet contact assembly, reverse procedure used to remove it.

TAPEREADER CLUTCH TRIP MAGNET ASSEMBLY

- 2.05 To remove tape reader clutch trip magnet assembly (Figure 3), proceed as follows.

- (a) Remove the tape reader feed magnet contact assembly.
- (b) Remove plug no. 4 and, with extractor tool TP182697, remove terminals no. 11 and 12.
- (c) Loosen the two TP180989 distributor disc mounting screws and the TP180798 magnet bracket mounting screw.
- (d) Remove tape reader clutch trip magnet assembly.
- (e) To replace tape reader clutch trip magnet assembly, reverse procedure used to remove it.

33 TAPE PUNCH

GENERAL DESCRIPTION AND PRINCIPLES OF OPERATION

CONTENTS	PAGE
1. GENERAL	1
2. TECHNICAL DATA	2
3. DETAILED OPERATION	2
DRIVE MECHANISM	4
INTELLIGENCE TRANSFER MECHANISM	4
TAPE FEED MECHANISM	6
TAPE GUIDE MECHANISM	7
PUNCH BLOCK MECHANISM	7
BACKSPACE MECHANISM	8
4. CONTROL FEATURES	8
MANUAL PUNCH	8
AUTOMATIC PUNCH	10
REMOTE ON/OFF PUNCH	12
5. VARIABLE FEATURES	12

1. GENERAL

1.01 This section provides a general description and principles of operation for the 33 tape punch (Figure 1). It is reissued to include information on the remote on-off punch for Computer Input/Output Sets, the tape punch for 3300 Series Coded Sets, and to incorporate some corrections. Because the revision is fairly extensive marginal arrows ordinarily used to indicate changes or additions have not been used.

1.02 The 33 tape punch is an 8-level device which perforates paper tape according to ASCII (American National Standard Code for Information Interchange). The tape punch does

not receive signals from a transmitting set directly but uses the coded arrangement of the typing unit codebars. The 33 tape punch is a generic title referring to three basic types of punches, a manual, an automatic, and a remote on-off punch.

1.03 The manual punch is turned on or off manually. It has four pushbuttons: ON, OFF, B.SP., and REL.

1.04 The automatic punch can be turned on or off both manually and automatically. For manual operation these pushbuttons are present on the lid: ON, OFF, B.SP., REL. In automatic operation the tape punch will turn on upon receipt of the DC2 code and turn off upon receipt of the DC4 code.

1.05 The 3300 Series Coded Sets are equipped with a manual/automatic punch, that is, the punch may be operated as a manual punch or as an automatic punch. The punch, as shipped from the factory, has two clips installed in slots A-0 and A-8 which enable the punch for manual operation. Removing the clips enables the punch for automatic operation. Refer to Figure 2 for positions of the A-0 and A-8 slots.

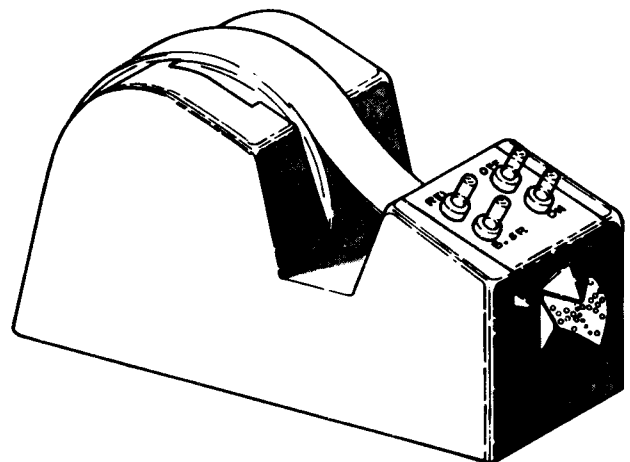

Figure 1 - 33 Tape Punch

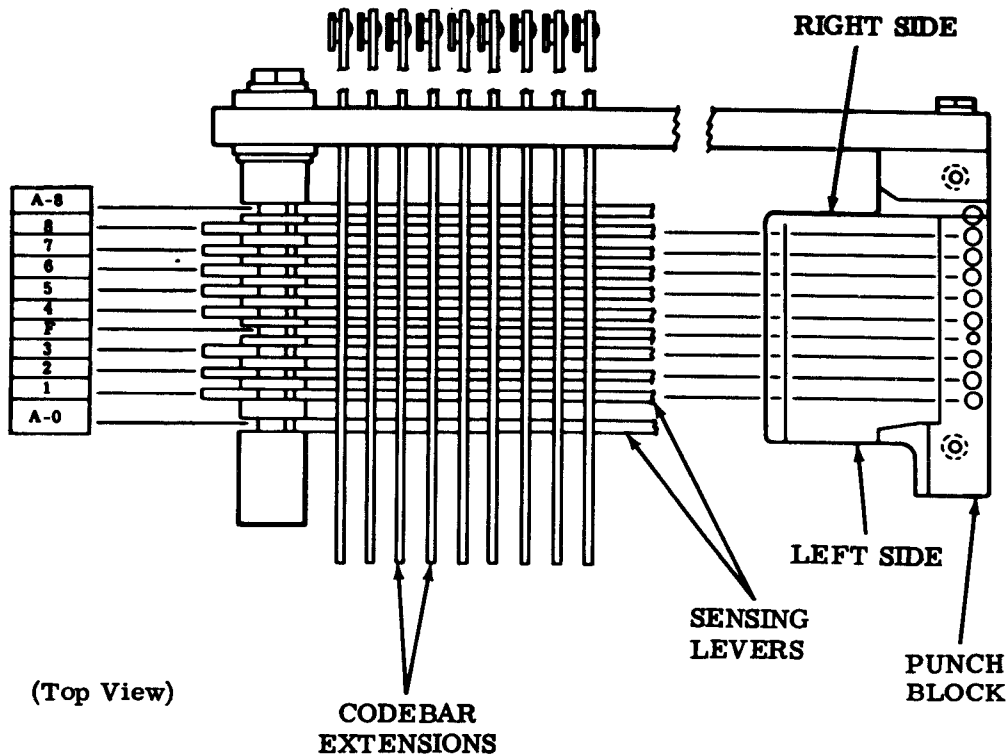

Figure 2 - Sensing Levers Slot Assignment

1.06 The remote on-off punch is solenoid operated. When the solenoid is energized the punch is off. With the solenoid de-energized the punch is on. Since the solenoid responds to remote signals there are no ON or OFF push-buttons on the lid. The only pushbuttons present are B.SP. and REL. The remote on-off tape punch is used on Computer Input/Output Sets.

1.07 References to left, right, front, or rear, etc, consider the tape punch as viewed by the teletypewriter operator.

1.08 In the illustrations fixed pivots are solid black and floating points, those mounted on parts that move, are cross-hatched.

2. TECHNICAL DATA

Note: This equipment is intended to be operated in a room environment within the temperature range of 40°F to 110°F. Serious damage to it could result if this range is exceeded. In this connection, particular caution should be exercised in using acoustical or other enclosures.

2.01 Dimensions and Weight

Width	4 inches
Height	6 inches
Depth	6 inches
Weight	21 ounces

2.02 Tape Specifications

Level	8 level
Width	1 inch
Code combination per inch	10
Feed hole diameter	0.046 inch

2.03 Chad Box

Width	2 inches
Length	6.5 inches
Height	7.5 inches

2.04 The 33 tape punch is capable of operating at 60, 66, 75, or 100 words per minute.

3. DETAILED OPERATION

Note: The following paragraphs give a detailed description of the major mechanisms (Figure 3) in the punch. This description applies to all three of the punches mentioned in 1.02 thru 1.06. Control features peculiar to each punch will be discussed in Part 4.

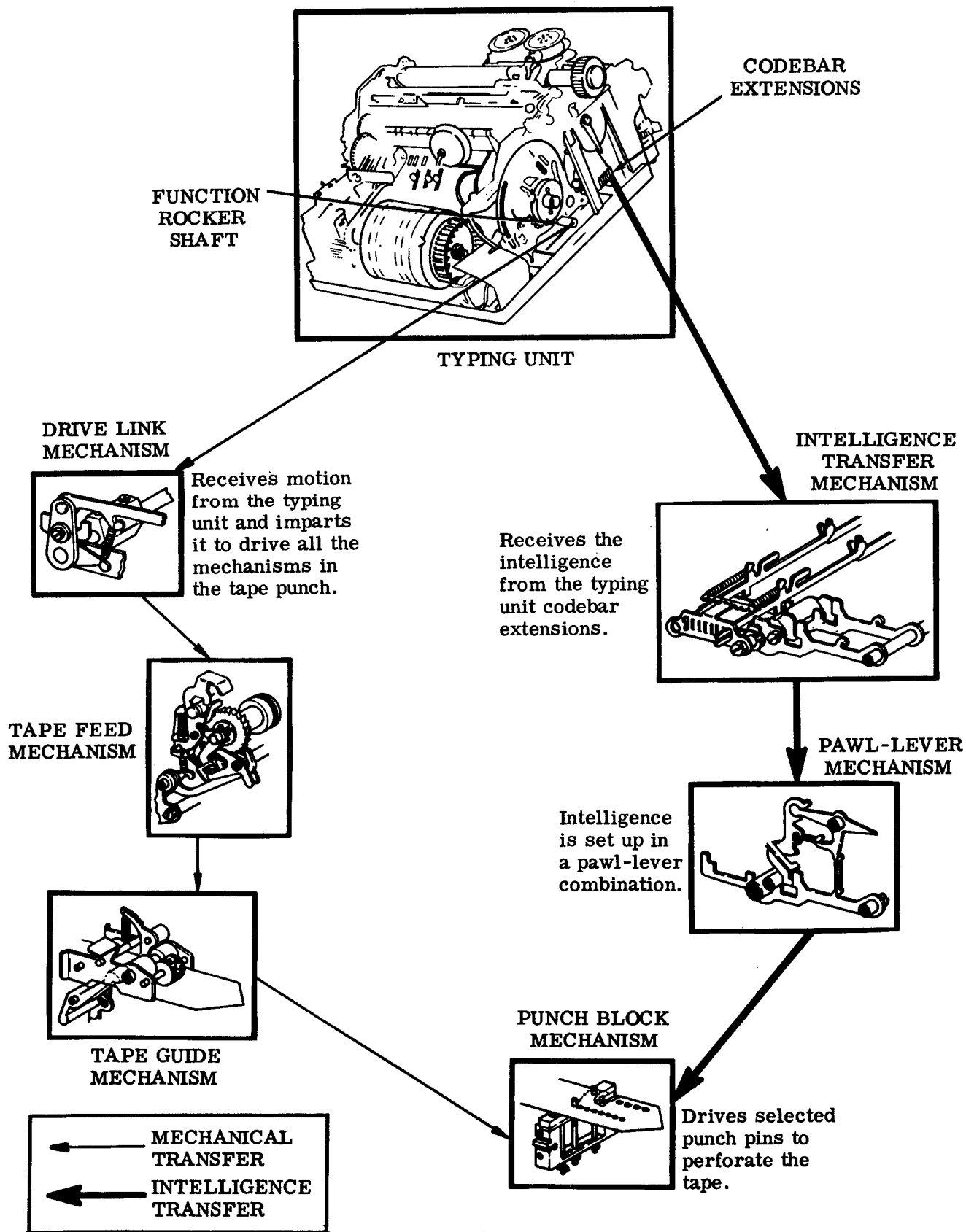

Figure 3 - Functional Diagram of the Tape Punch and Major Mechanisms

DRIVE MECHANISM

3.01 The rocking motion of the typing unit function rocker shaft is imparted to the tape punch by means of a sleeve which connects to a plate with shaft (Figure 4). A drive link, attached to the plate with shaft, connects to a drive post which simultaneously drives the nudger, feed pawl, and stripper bail, and supplies the downward force to pull the selected pawls by means of the sensing lever bail.

INTELLIGENCE TRANSFER MECHANISM

3.02 There is a codebar extension (Figure 5) for each typing unit codebar. Motion is imparted to the codebar extensions by the codebars through the typing unit reset bail. A plate mounted to the tape punch casting guides the codebar extensions.

3.03 The typing unit selector blocking levers control the mark or space position of the codebars which, in turn, transfer this position to the codebar extensions. A blocked codebar represents a space; an unblocked codebar represents a mark.

3.04 Each codebar extension has a tab on its underside which lines up with its respective sensing lever, pawl, lever, and punch-pin combination.

3.05 During the drive mechanism's counter-clockwise travel, the sensing levers, under spring tension, move up and sense the codebar extensions. Each sensing lever, except the feed lever, has a tab on its top side which lines up with its respective codebar extension.

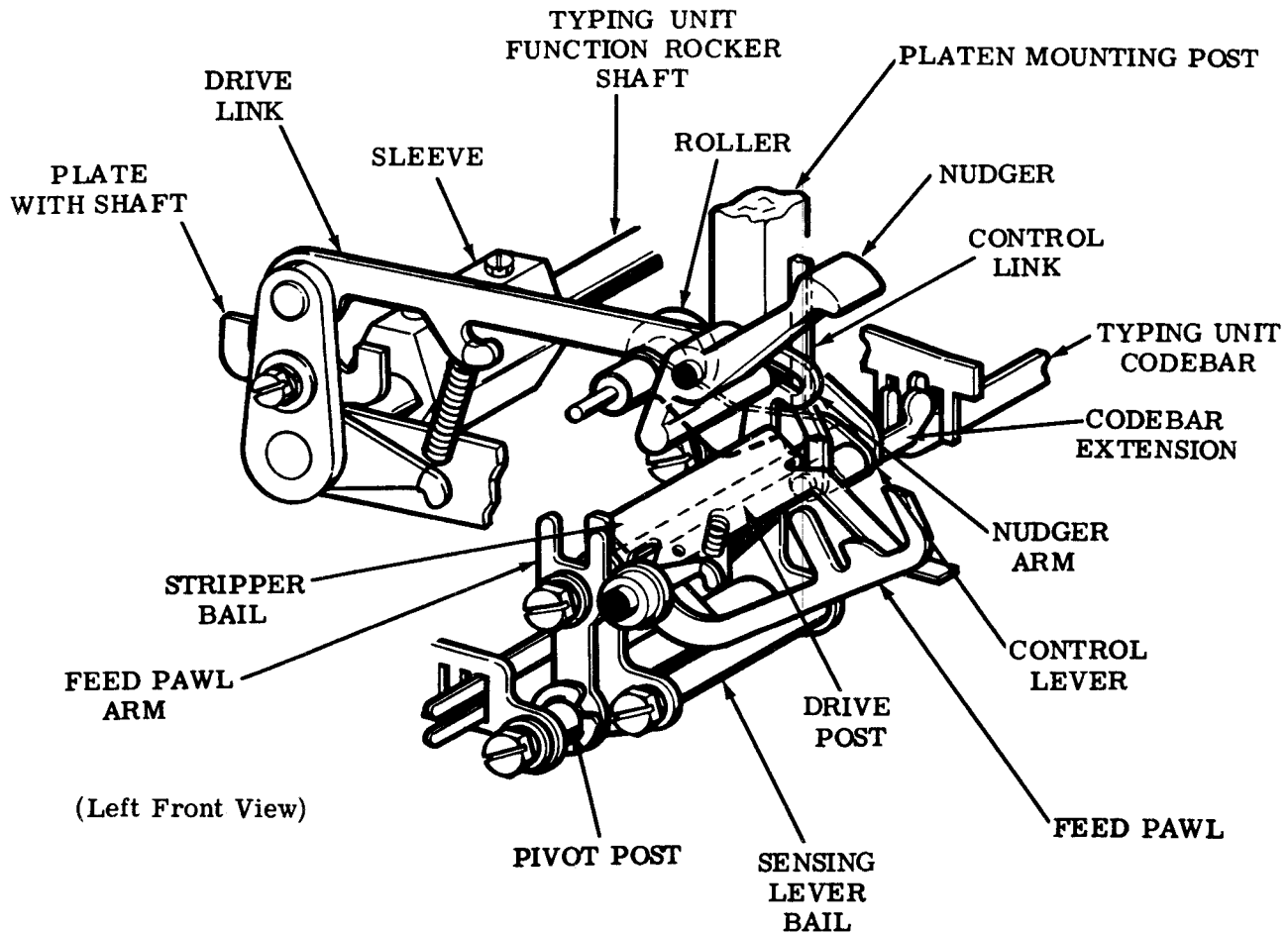

Figure 4 - Drive Link Mechanism and Drive Mechanism

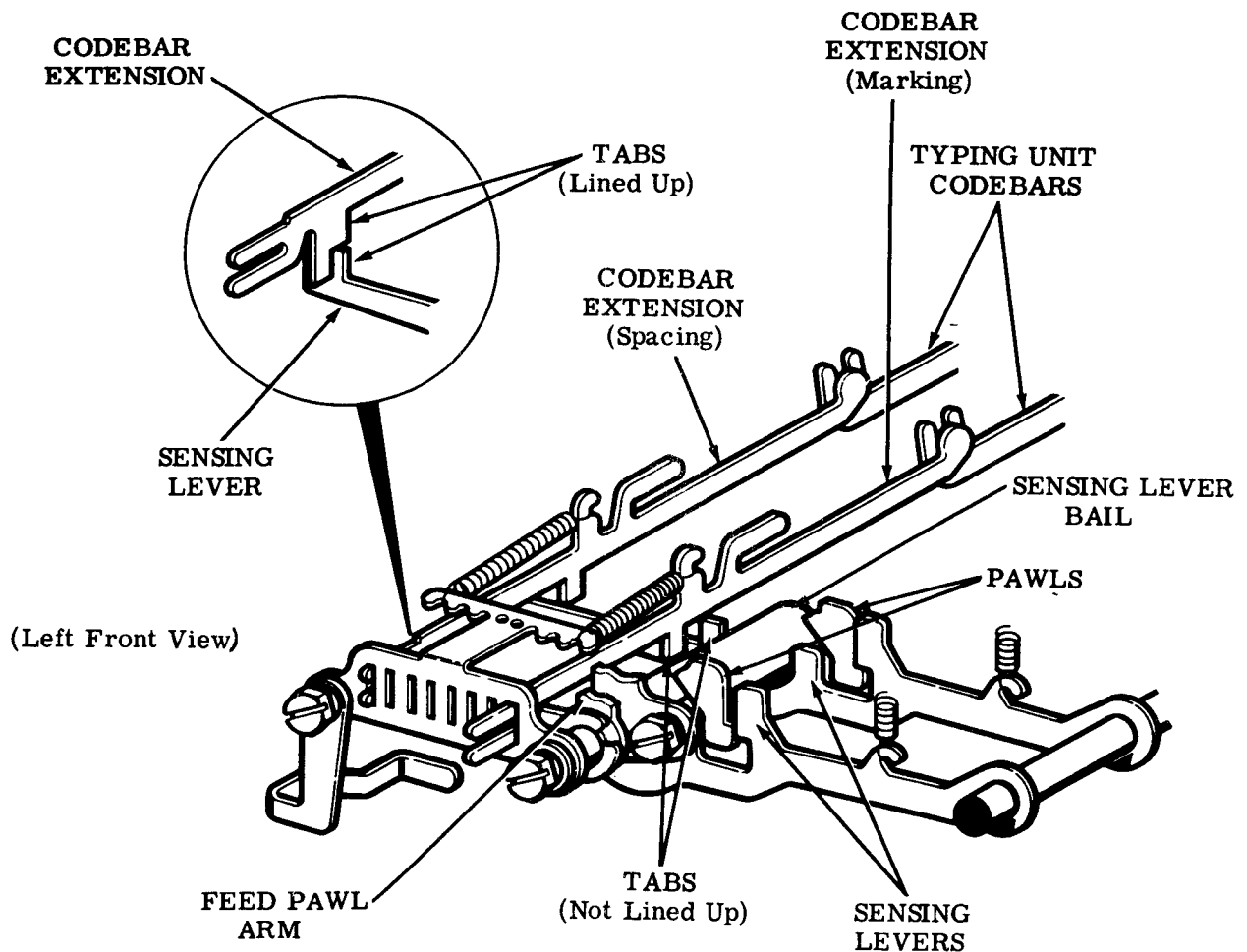

Figure 5 - Intelligence Transfer Mechanism

3.06 When a codebar extension is spacing, the tab, located on its underside, lines up with the tab on the sensing lever. The tabs engage each other, and the sensing lever is blocked from pivoting to its most counterclockwise position.

3.07 When a codebar extension is marking, its tab is not in line with the sensing lever tab. As a result the sensing lever pivots to its most clockwise position.

3.08 The feed sensing lever always travels to its most clockwise position, since it has no tabs. This motion is presented to the pawl, lever, and feed-punch pin combination through a latching surface on the pawl.

3.09 When the tape punch is off, each pawl is in its highest vertical position, each lever in its most clockwise position, and each code-punch pin in its most downward position — below the surface of the tape.

3.10 When a sensing lever is in the spacing position, its latching surface is prevented from engaging with its associated pawl latching surface. As a result the pawl is not selected.

3.11 When a sensing lever is in the marking position, its latching surface engages the latching surface on its associated pawl. When the two latching surfaces engage, the pawl is in the selected position.

3.12 As the drive mechanism (Figure 4) rotates clockwise, the feed pawl slides along the inclined surface of the adjacent ratchet tooth, drops behind it, and is cammed away from the feed wheel ratchet. Occurring simultaneously, the sensing levers in the marking position rotate counterclockwise and transfer their motion to the selected pawl, lever, and code-punch pin combination. At the same time, the drive mechanism transfers its motion to the sensing levers which are spacing. Since the pawl, lever, and code-punch pin combinations

are in the nonselected position, no motion is transferred to them. This results in no perforation of the tape, since the code-punch pins remain in their most downward position below the tape's surface. As the drive mechanism continues and reaches its most clockwise position, the code-punch pin of a selected pawl, lever, and code-punch pin combination travels upwards, perforates a hole in the tape, and continues to its most vertical position. The feed hole is always perforated in the tape since its pawl and lever are always selected.

3.13 Just prior to the end of the drive mechanism's most clockwise travel, the stripper bail, through its bias spring, engages a latching surface located under the spring hook(s) of the selected pawl(s). As the drive mechanism rotates counterclockwise to its stop position, the stripper bail strips the selected pawls from their sensing levers. The selected pawl, lever, and code-punch pin combinations return to their stop positions through their bias springs and the retractor mechanism. The lever bail of the drive mechanism also acts as a part of the retractor mechanism. As the stripper bail strips the pawls, a cam surface on the pawl, which acts as the other member of

the retractor mechanism, engages the sensing leverbail post and cams the pawl upwards to the stop position. During this portion of the drive mechanism's travel, the codebar extensions are reset by the codebar reset bail.

3.14 During the drive mechanism's clockwise motion, the nudger (Figure 4) performs its function. Motion is transferred from a cam profile, located on the nudger arm, through a post molded as an integral part of the nudger. The nudger rotates counterclockwise, engages, and nudges the tape gently when the selected code-punch pins are engaged with the tape. This enables the tape to be advanced a small amount without affecting tape feed spacing, since only the weight of the paper between the tape roll is reflected to the feed wheel when the tape is being advanced.

TAPE FEED MECHANISM

3.15 As the stripper bail moves to the rear, the feed pawl engages a tooth on the feed wheel ratchet (Figure 6). When the stripper bail completes its travel to the rear, the feed wheel ratchet has indexed one full tooth and the tape is advanced 0.100 inch by the feed wheel.

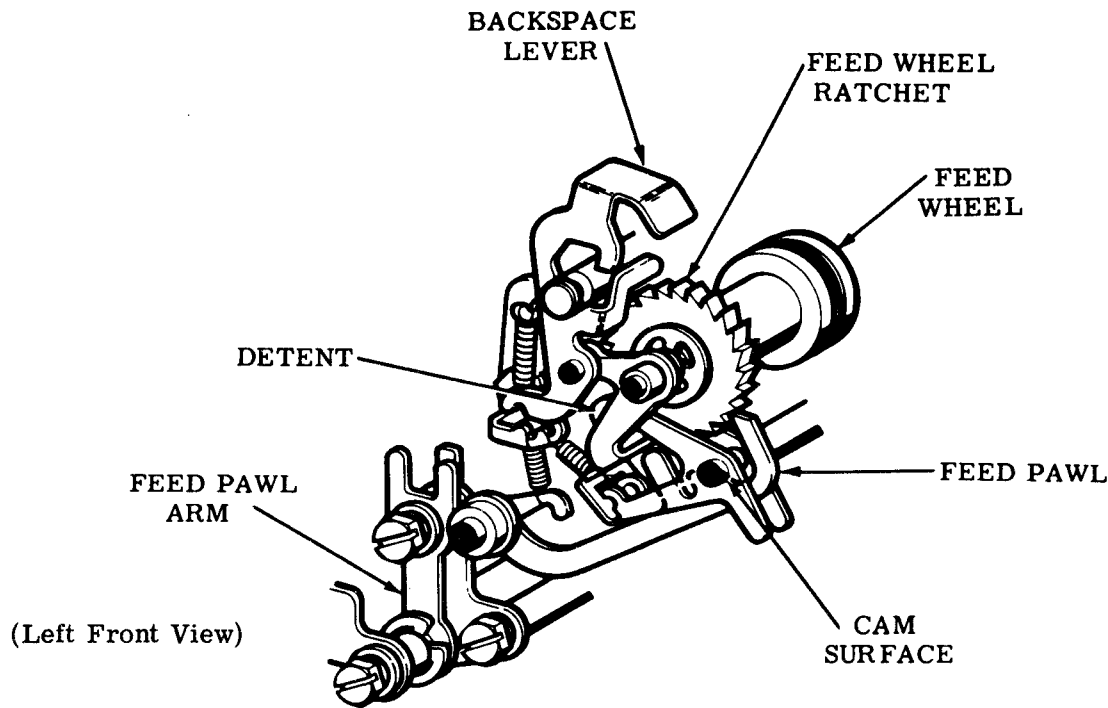

Figure 6 - Feed Wheel Mechanism (Tape Feed Mechanism)

TAPE GUIDE MECHANISM

3.16 The tape guide mechanism (Figure 7), consists of a bracket, two rollers, three posts, a sleeve, and a compression spring held together by retainers. A tension spring biases the tape guide mechanism in a clockwise direction. The knurled roller settles against the knurled feed wheel with a predetermined force. It is the combination of force and the knurled wheels that provides adequate tape spacing. The tape guide assembly is shaped in the form of a funnel to provide easy tape threading. A push-button (Figure 9), located in the cover lid, when manually pushed down against a tab located on

the REL. bracket, disengages the tape guide assembly from the feed wheel, thereby providing easy tape removal from the tape punch.

PUNCH BLOCK MECHANISM

3.17 The punch block mechanism consists of code-punch pins, a feed-punch pin, holder, die plate, and a tape bias spring (Figure 8). The code-punch pin and feed-punch pin are oriented to the die plate through slots which engage levers for their respective code level. The tape bias spring always biases the tape against one edge of the holder. This results in the code hole and feed hole relation to the tape edge to be held constant.

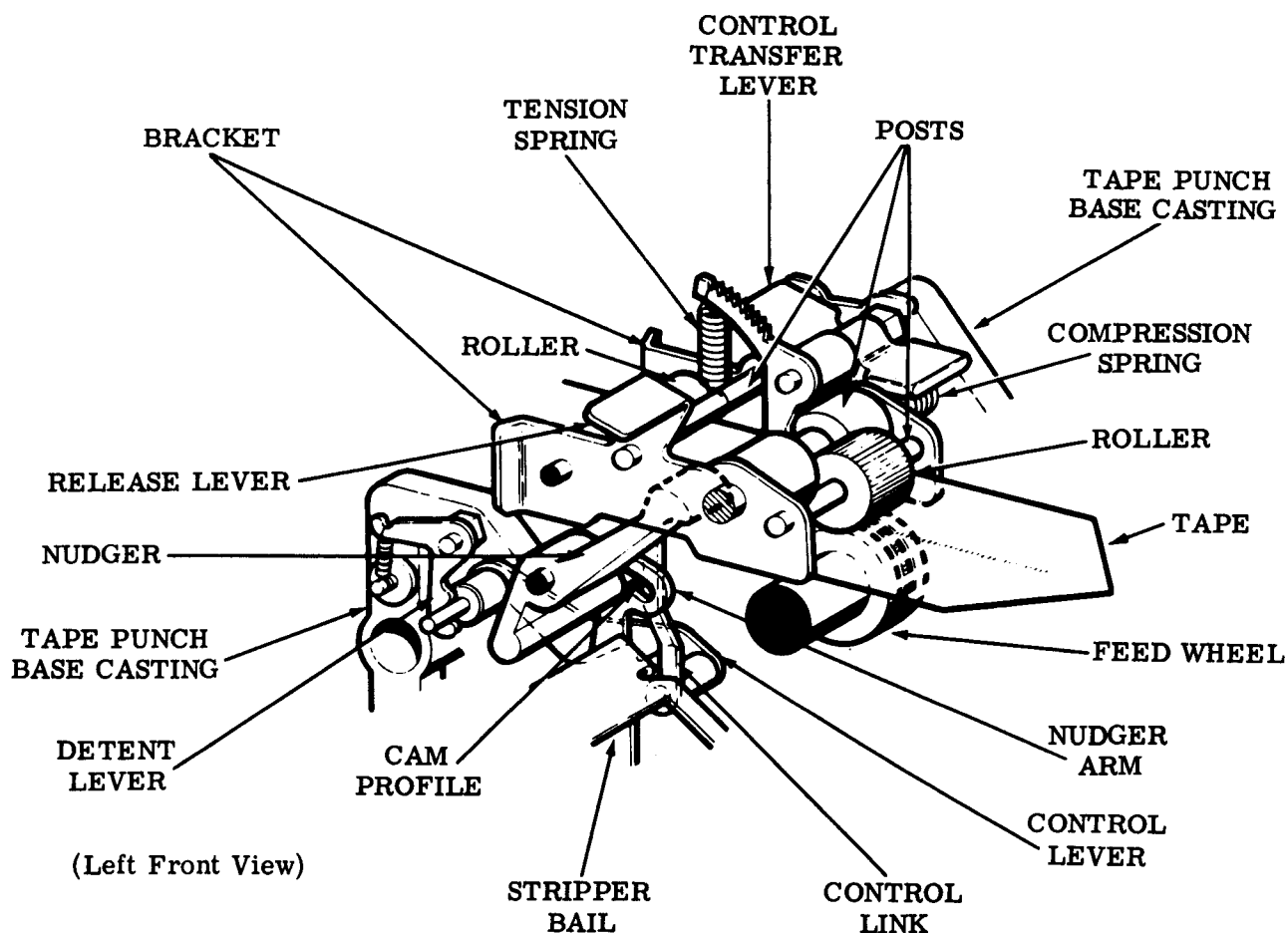

Figure 7 - Tape Guide Assembly (Tape Feed Mechanism)

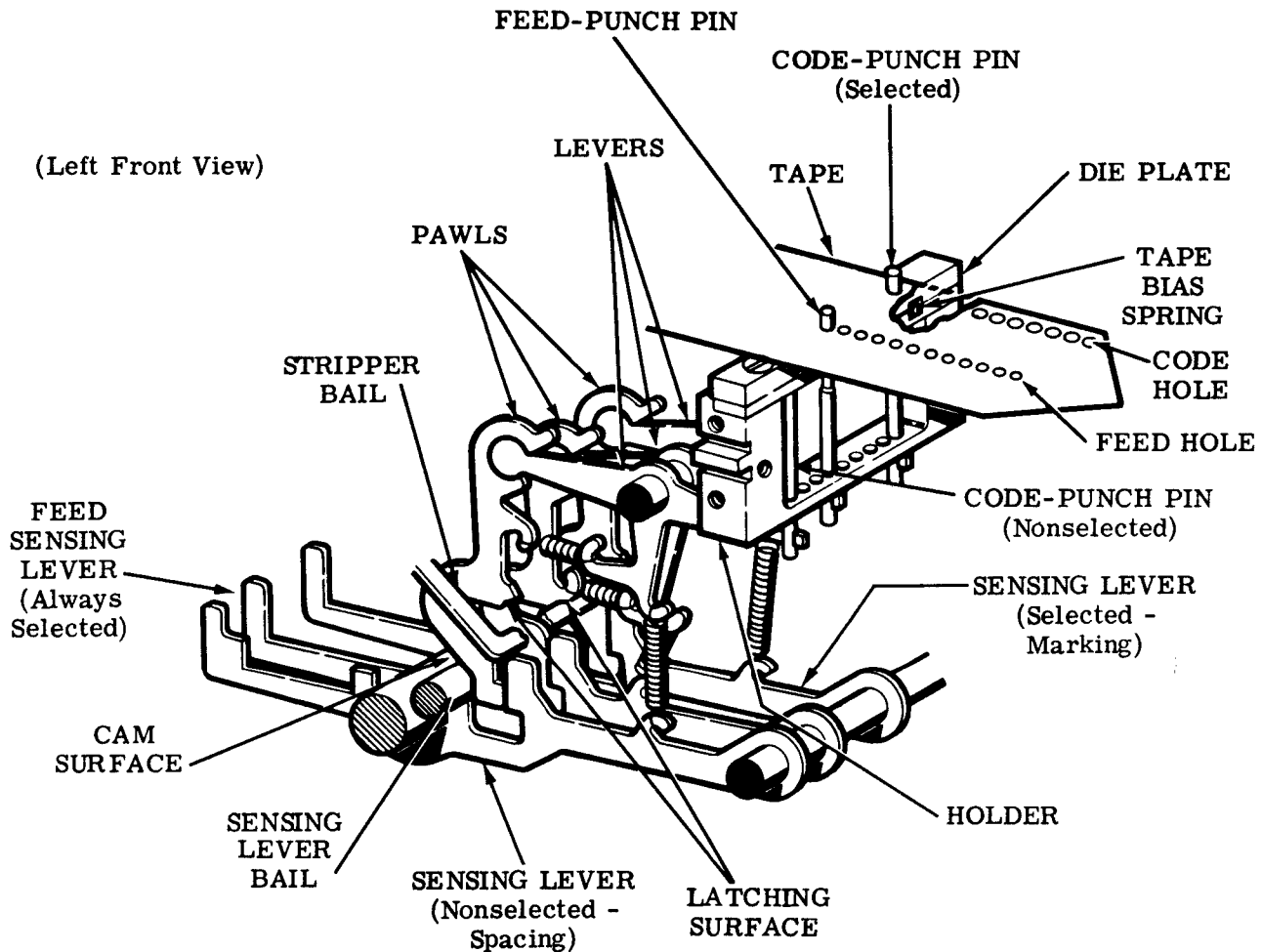

Figure 8 - Tape Punch Mechanism

BACKSPACE MECHANISM

3.18 The backspace lever (Figure 6), when depressed manually to its most downward position, backspaces the feed wheel ratchet one tooth space. This results in the tape being backspaced one full character. The backspace lever, through another lever, cams out the feed pawl during the backspace operation. This is a safety feature to prevent a jam if the operator accidentally operates the backspace mechanism while the tape punch is running.

4. CONTROL FEATURES

MANUAL PUNCH

4.01 The manual punch has four pushbuttons: ON, OFF, B.SP., and REL. (Figure 9), whose functions are:

ON — When the ON pushbutton on the cover is depressed, (Figure 10) the control transfer lever operates a

control link which, in turn, rotates the control lever. The control lever has a roller on one end and a detent on the other. The detent engages a drive post while the roller guides the drive link. When the control lever is rotated in the ON mode, the detent disengages from the drive post while the roller pivots downward. The drive link, under spring tension, is pulled downward to engage the drive post.

OFF — When the OFF pushbutton on the cover is depressed, the control transfer lever operates the control link and then the control lever is operated. The detent on the control lever travels downward to engage the drive post while the roller pivots upward, disengaging the drive link from the drive post.

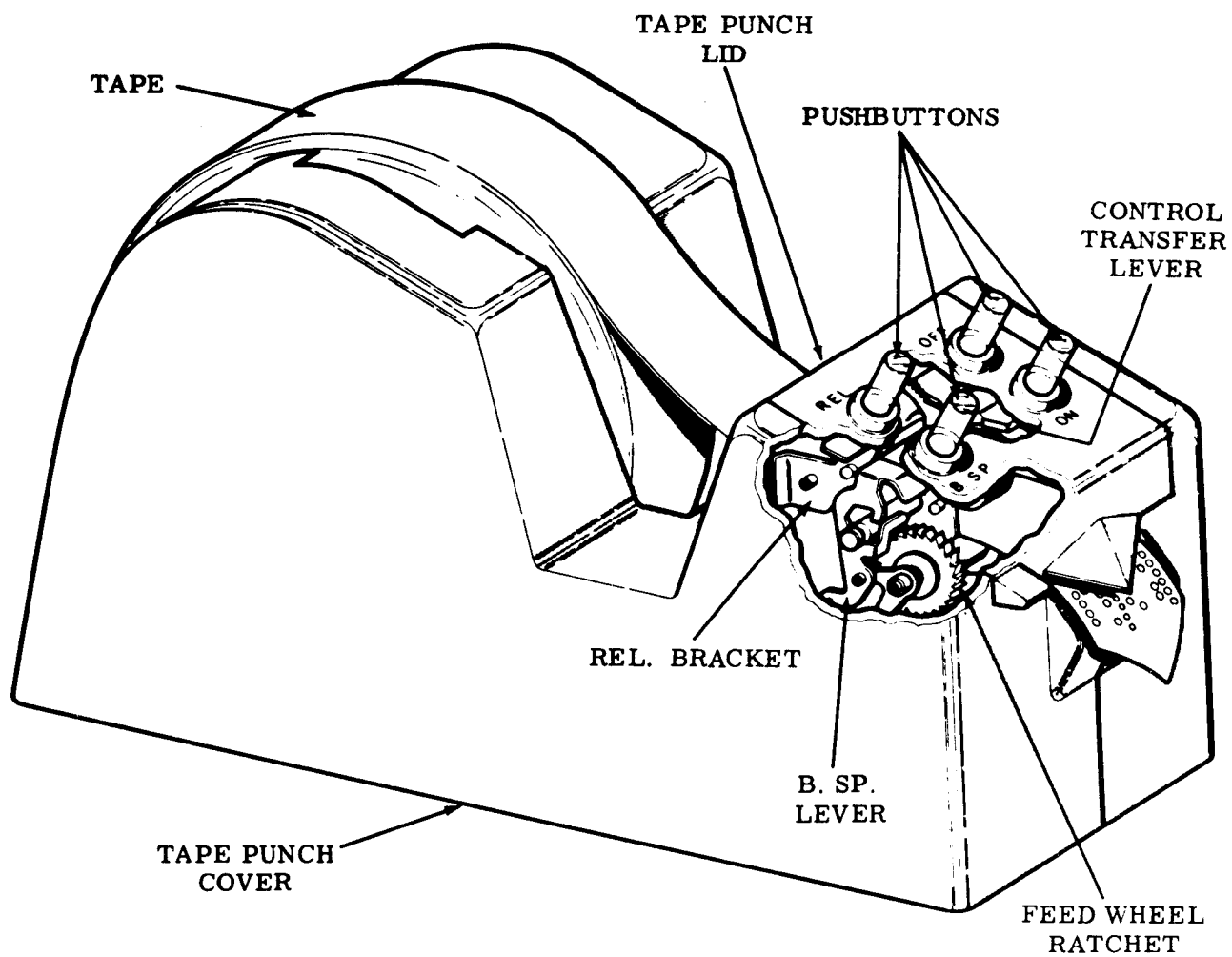

(Left Front View)

Figure 9 - Control Mechanism

B.SP. — When the B.SP. pushbutton on the cover is depressed, the backspace mechanism, described in 3.18, is operated. The backspace lever, when depressed, moves down to engage a tooth on the back side of the feed wheel ratchet (Figure 11). Simultaneously, a lever pivots the feed pawl away from the feed wheel ratchet which then turns counterclockwise, backspacing one tooth. The feed wheel is mounted on the same shaft as the ratchet. When the ratchet backspaces, the feed wheel also backspaces.

REL. — When the REL. pushbutton on the cover is depressed, the entire backspace mechanism (Figure 7) pivots counterclockwise raising the roller away from the feed wheel. The tape can thus be pulled out freely.

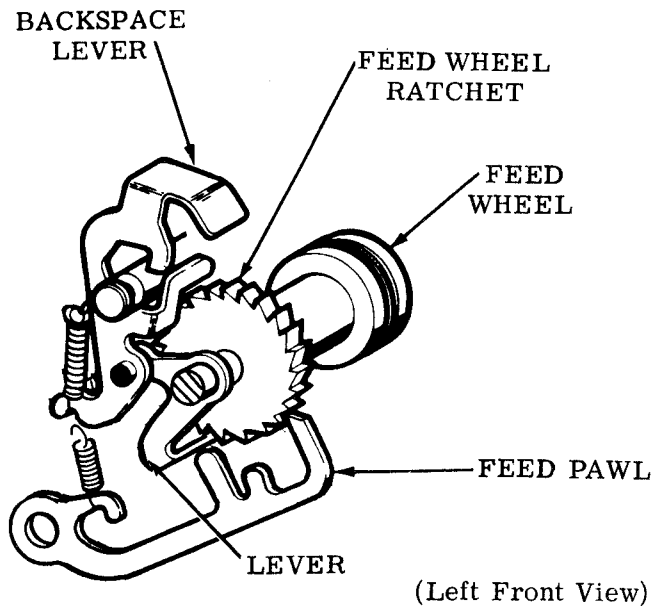

Figure 11 - Feed Wheel Mechanism
(Tape Feed Mechanism)

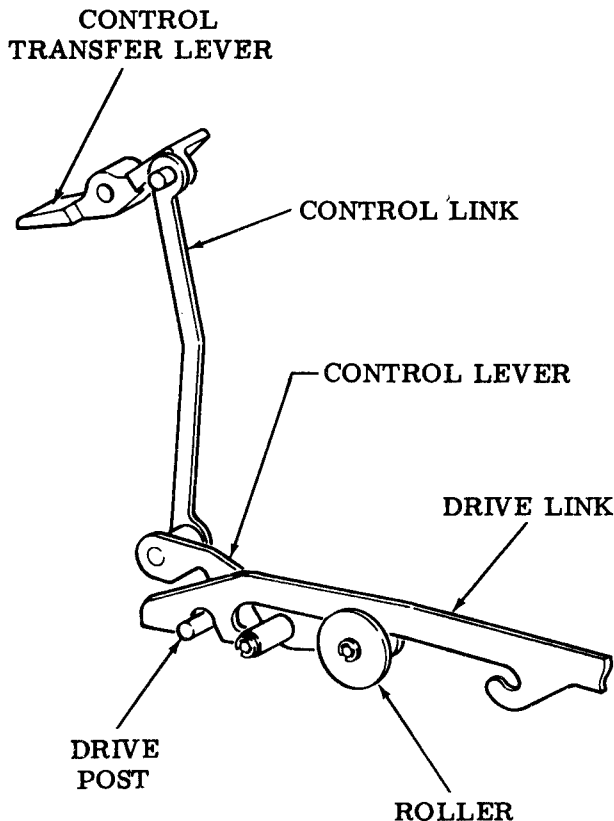

Figure 10 - Manual ON and OFF
Mechanism

AUTOMATIC PUNCH

4.02 The automatic punch has four pushbuttons, similar to the manual punch. The pushbuttons are: ON, OFF, B.SP., and REL.

ON — Depressing the ON pushbutton (Figure 12) on the cover lid causes a lever, link, the lever assembly, and the link with stud to pivot. In its pivoting motion, the stud causes the latch bail to pivot counterclockwise disengaging the ON-OFF bail lever, allowing it to move towards the rear. In this rearward travel the stud, which in the OFF condition holds the feed pawl down away from the feed wheel ratchet, also moves towards the rear allowing the feed pawl to reach up and engage a tooth on the feed wheel ratchet.

OFF — When the OFF pushbutton (Figure 12) is depressed, its lever is pivoted away from the engaging surface of the ON lever allowing the spring-biased levers to return to their OFF position. The latch bail pivots upward to engage the ON-OFF bail lever and the stud moves the feed pawl downward away from the feed wheel ratchet teeth.

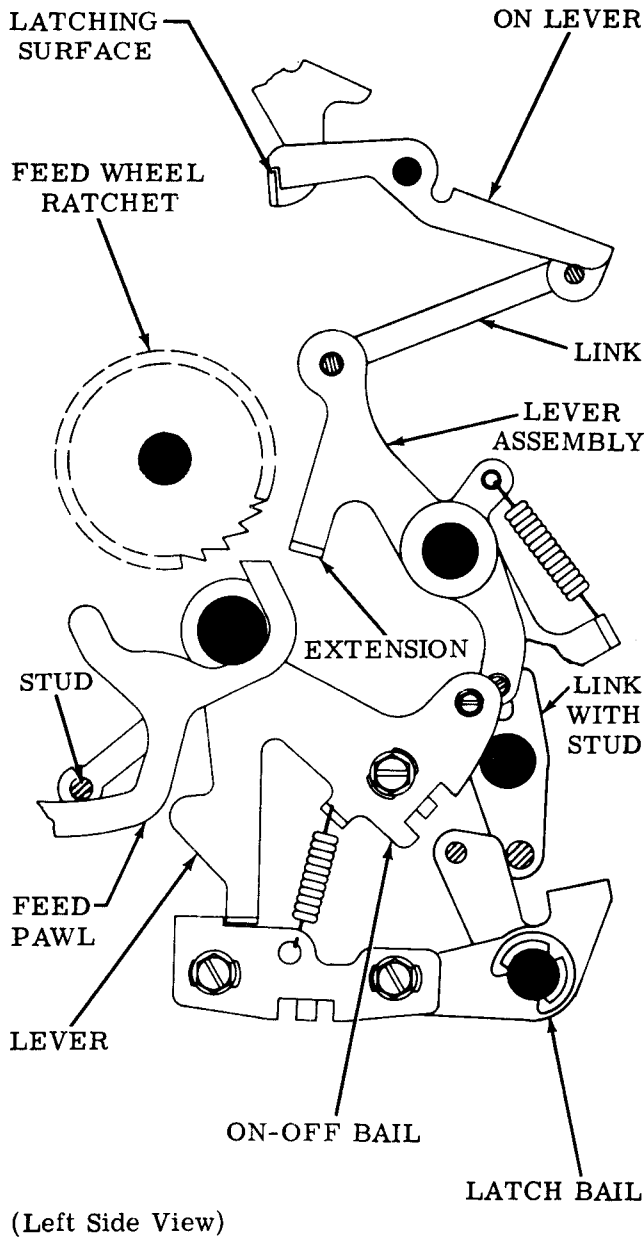

(Left Side View)

Figure 12 - Automatic ON and OFF Mechanism

B.SP. — Same as the manual punch back-space operation described in 4.01

REL. — Same as the manual punch release operation described in 4.01

4.03 Automatic ON (Figure 13) — For turning the tape punch ON automatically the same mechanism that turns it ON manually is used. When the "R" and "Control" keytops of the local

set or the distant set are depressed, a code combination is set up in the typing unit codebars and codebar extensions. The A-8 sensing lever senses the codebar extensions and travels upwards, positioning a pawl and lever. In its pivoting motion the lever engages an extension of the lever assembly causing it to pivot as described in 4.02. The pivoting action of the lever assembly causes the link with stud to pivot. Subsequently, the latch bail moves downward disengaging the ON-OFF bail whose stud moves away from the feed pawl. The feed pawl then reaches up to engage a tooth on the feed wheel ratchet.

4.04 Automatic OFF (Figure 14) — When the "T" and the "Control" keytops are depressed on the keyboard, the tape punch OFF code combination is set up in the typing unit codebars and codebar extensions. The A-0 sensing lever senses the codebar extensions and positions a pawl and lever. The lever has an extension which causes the post of the ON-OFF bail to move upward. Simultaneously, the stud engages the feed pawl and pulls it down disengaging it

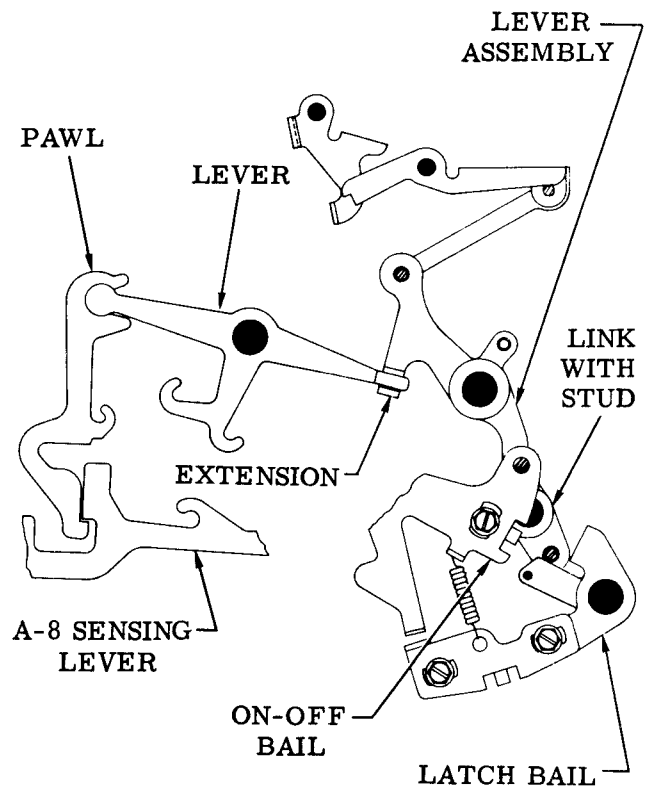

(Left Side View)

Figure 13 - Automatic ON Mechanism

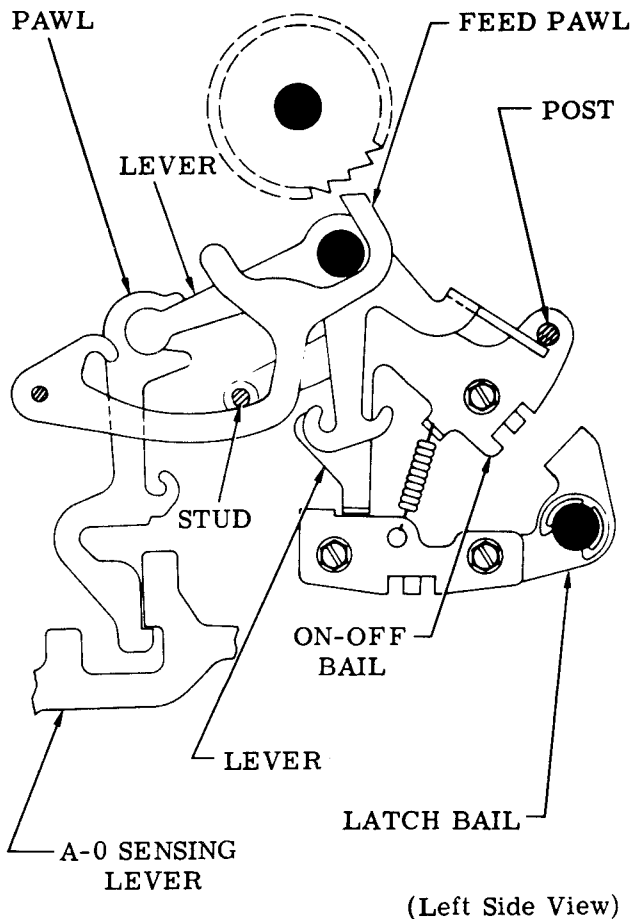

(Left Side View)

Figure 14 - Automatic OFF Mechanism

from the feed wheel ratchet. The ON-OFF bail lever drops in the engaging surface of the spring biased latch bail. During subsequent cycles, the sensing levers will sense incoming code combinations but the selected pawls will be stripped each time. Likewise, there will be no action of the feed pawl and the tape will not be advanced.

REMOTE ON/OFF PUNCH

4.05 The remote on/off punch has two push-buttons: B.SP. and REL. The ON and OFF pushbuttons present on the manual and automatic punches are not present on this punch.

4.06 The remote on/off punch is turned on and off by means of a solenoid located between the typing unit casting and the right side of the tape punch. The solenoid will energize upon command from the PUNCH ON button on the set control switch assembly or when the set receives the DC2 (Tape Punch On) code.

4.07 When the punch is off, the solenoid (Figure 15) is energized, causing the plunger to be drawn into the coil. With the plunger pulled into the coil the solenoid bail extension is pivoted to the left, raising the roller. As the drive link is driven forward and backwards in response to the action of the function rocker shaft it fails to engage the drive post and the punch fails to operate.

4.08 Receipt of the punch on code de-energizes the solenoid. Due to spring tension the solenoid bail extension pivots to the right. The roller moves downward allowing the spring biased drive link to engage the drive post when the drive link is moved back and forth in response to the action of the function rocker shaft.

5. VARIABLE FEATURES

5.01 Tape Punch Interlock - When the typing unit is in a nonprint condition, the nonprint codebar connects to a post on the right side of the latch bail and cams it in a counterclockwise direction. This action turns the tape punch on and prevents it from being turned off as long as the codebar remains in the nonprint mode. When the nonprint codebar is not in the nonprint mode, the ON-OFF mechanism returns to its normal condition.

5.02 ON-LOCK - This variable feature consists of an ON-LOCK pushbutton on the tape punch cover which, when depressed, locks the ON lever so that the OFF lever is disabled and cannot be operated. The tape punch will be on as long as the ON-LOCK pushbutton is held down.

5.03 UNLOCK - This variable feature consists of an UNLOCK pushbutton on the tape punch cover which, when depressed, removes the locked condition described in 5.14. Depressing the UNLOCK pushbutton will not turn the tape punch off, but will allow the tape punch to accept an OFF signal. It will then be able to turn off automatically.

5.04 Code Option - The codebar extensions may be coded with various code combinations to turn the tape punch on or off. For the ON mode the no. 7 bit should be a spacing bit so no interference will occur between the no. 7 codebar extension tab and no. 7 sensing lever tab.

5.05 E. O. T. - The tape punch can be turned off when the end of transmission code is selected. The A-0 sensing lever is coded to

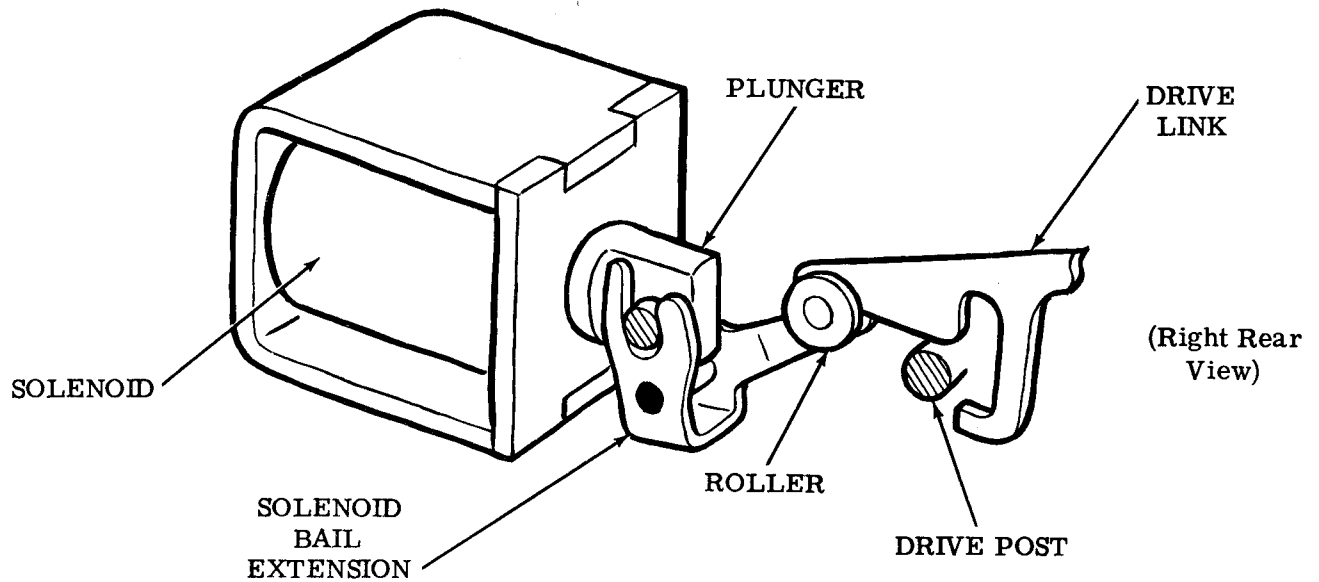

Figure 15 - Solenoid Mechanism for Remote ON/OFF Tape Punch

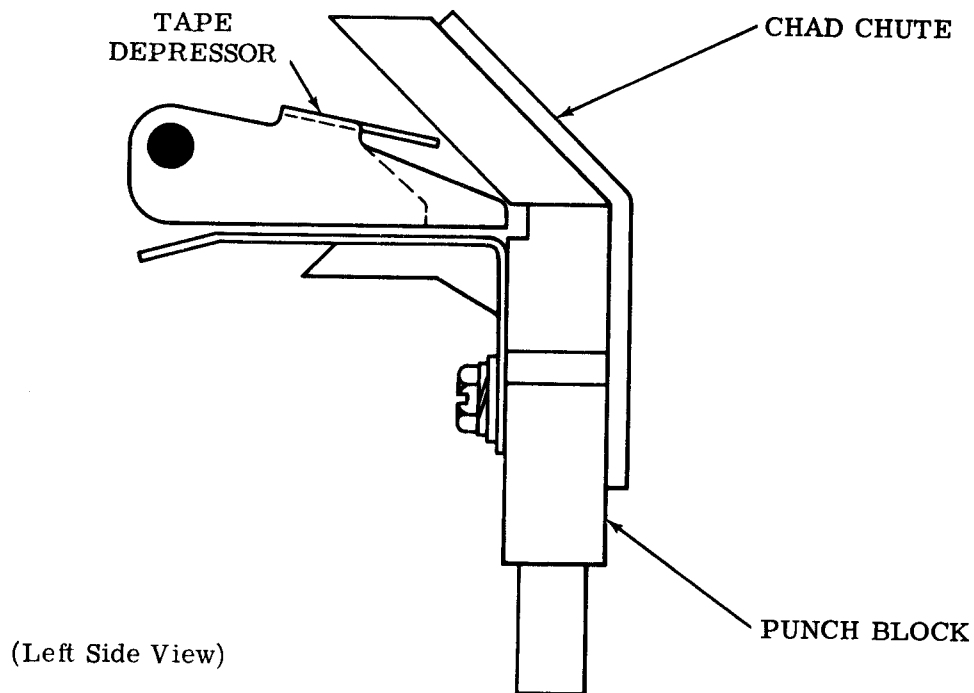

Figure 16 - Tape Guide for Folded Tape

read the E. O. T. code combination and will originate the motion to turn the tape punch off as described in 4.04.

5.06 Sense Suppression - This mechanism blocks the sensing levers from sensing when the tape punch is off.

5.07 Tape Guide For Folded Tape — This feature allows the use of folded tape without the tape becoming jammed in the punch block. The mechanism consists of a shelf attached to the punch block, between the roller and the punch block, and a tape depressor straddling the roller above the tape. Refer to Figures 7 and 16.

33 TAPE PUNCH

LUBRICATION

CONTENTS	PAGE
1. GENERAL	1
2. BASIC UNIT	2
Backspace lever	8
Codebar levers	5
Control mechanism	5
Detent lever	8
Drive link mechanism area	2
Drive link mechanism (Early design)	3
Drive link mechanism (Late design) . .	3
Feed mechanism	7
Feed pawl	7
Pawls and levers	6
Punch block assembly	9
Sensing levers	6
Stripper bail	6
Support link (Late design)	3
Tape guide assembly	8
Tape guide roller	9
Tape punch	4
3. VARIATIONS TO THE BASIC UNIT . .	10
Automatic on-off bail drive lever . . .	11
Automatic on-off control bail	11
Automatic on-off control levers	12
Automatic on-off control mechanisms	13
Automatic tape punch	10
LOCK "ON" mechanism	14
Punch interlock mechanism	14
Sense suppression mechanism	15
4. VARIABLE FEATURE	16 ←
Tape guide for folded tape	16 ←

1.02 The general lubrication areas are illustrated by photographs. The specific points to receive lubricant are indicated on line drawings with appropriate textual instructions. Line drawings and textual instructions follow each photograph and are keyed to the photograph by paragraph numbers.

1.03 Thoroughly lubricate the tape punch, but avoid overlubrication that might permit the lubricant to drip or be thrown onto adjacent parts. Saturate all felt washers and oilers with oil.

1.04 Lubricate the tape punch before placing it into service or prior to storage. After a short period of service, relubricate it to make sure no areas have been missed. Thereafter, lubricate the tape punch at regular intervals as indicated below:

<u>Operating Speed</u> (Words per Minute)	<u>Lubrication</u> <u>Interval</u>
100	500 hours* or 6 months**

*Station set operating hours.
 **Whichever comes first.

1.05 The textual instructions that accompany the line drawings consist of abbreviated directions specific lubrication points, and parts affected. The meanings of the abbreviated directions (symbols) are given below.

<u>Symbol</u>	<u>Meaning</u>
D	Keep dry — no lubricant permitted.
O	Oil (KS7470).

1. GENERAL

1.01 This section provides lubrication requirements for the 33 tape punch. It is reissued to add lubrication requirements for the tape guide for folded tape. Marginal arrows indicate changes and additions.

1.06 References to left, right, front, or rear, etc consider the tape punch to be viewed from a position where the tape guide assembly faces up and the backspace lever is to the viewer's left. Orientation references in the drive link mechanism area consider the drive link to be up and located to the viewer's left.

CAUTION: DO NOT USE ALCOHOL, MINERAL SPIRITS, OR OTHER SOLVENTS TO CLEAN PLASTIC PARTS OR PARTS WITH PROTECTIVE-DECORATIVE FINISHES. NORMALLY, A SOFT, DRY CLOTH SHOULD BE USED TO REMOVE DUST, OIL, GREASE, OR OTHERWISE CLEAN PARTS OR SUBASSEMBLIES. IF NECESSARY, A SOFT CLOTH DAMPENED WITH SOAP OR MILD DETERGENT MAY BE USED. AFTERWARDS,

RINSE EACH CLEANED PART OF SUBASSEMBLY WITH A SOFT, DAMP CLOTH AND BUFF WITH A SOFT, DRY CLOTH.

1.07 Tools and materials needed for teletypewriter lubrication are listed in Section 570-005-800TC.

1.08 For disassembly and reassembly information refer to Section 574-125-702TC.

2. BASIC UNIT

2.01 Drive link Mechanism Area

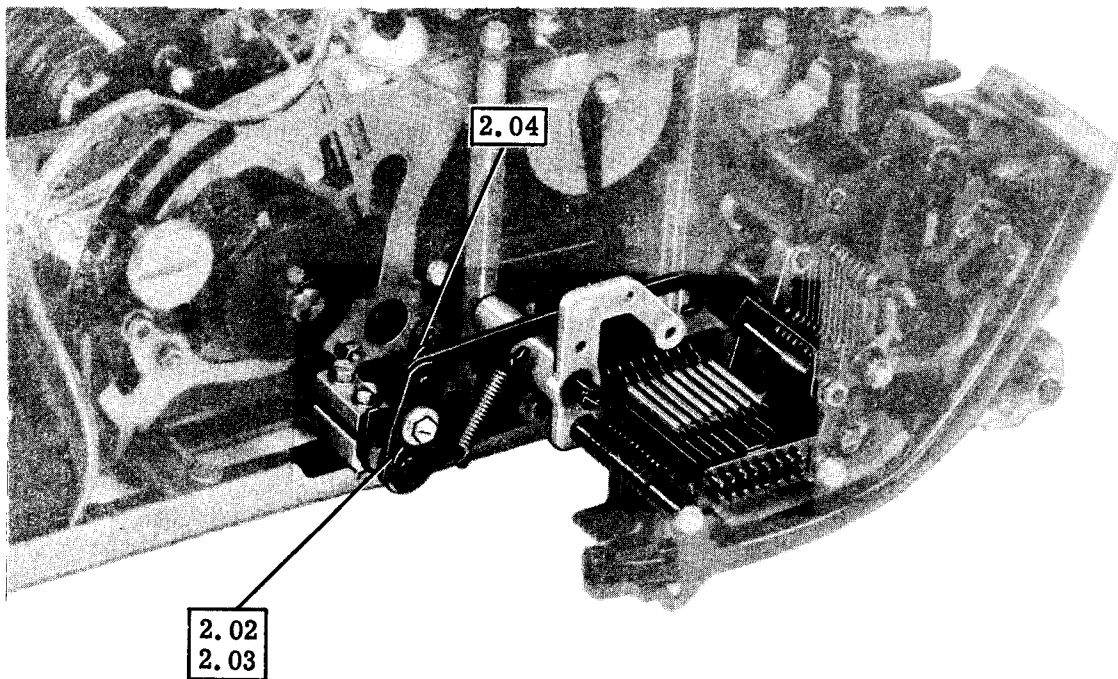

(Left Side View)

2.02 Drive Link Mechanism (Early Design)

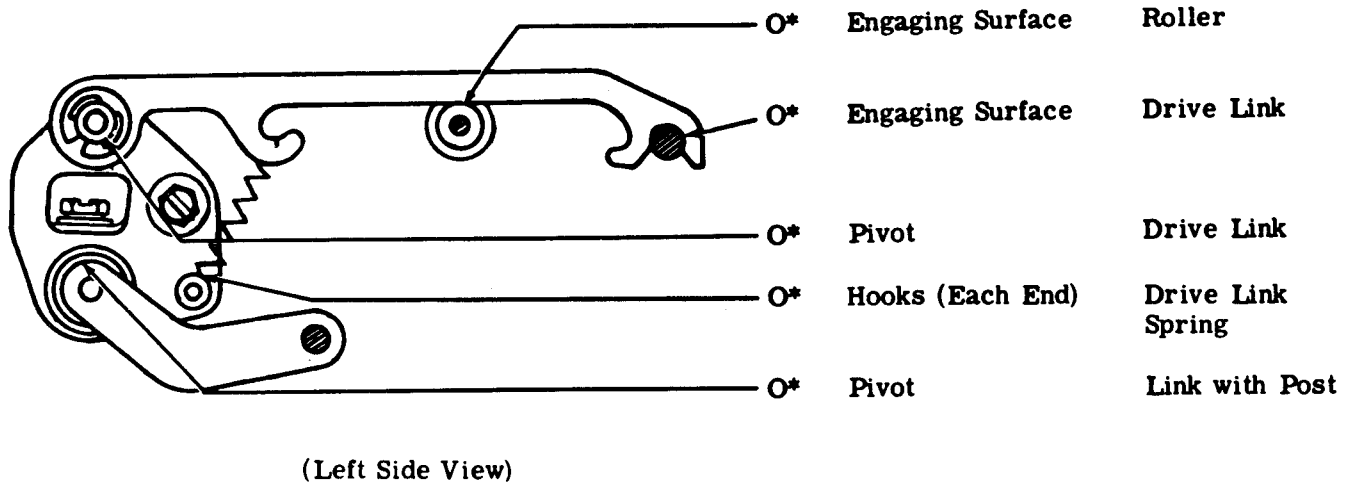

2.03 Drive Link Mechanism (Late Design)

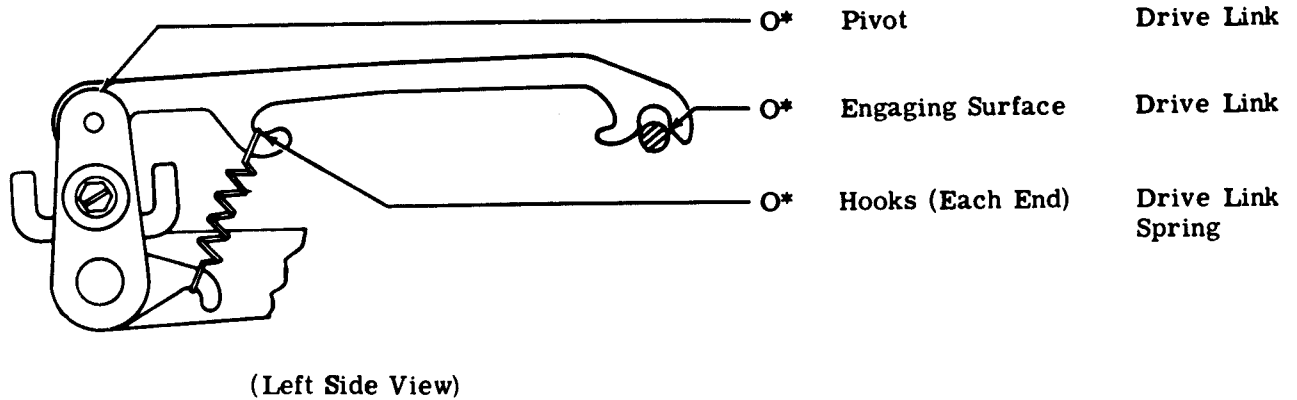

2.04 Support Link (Late Design)

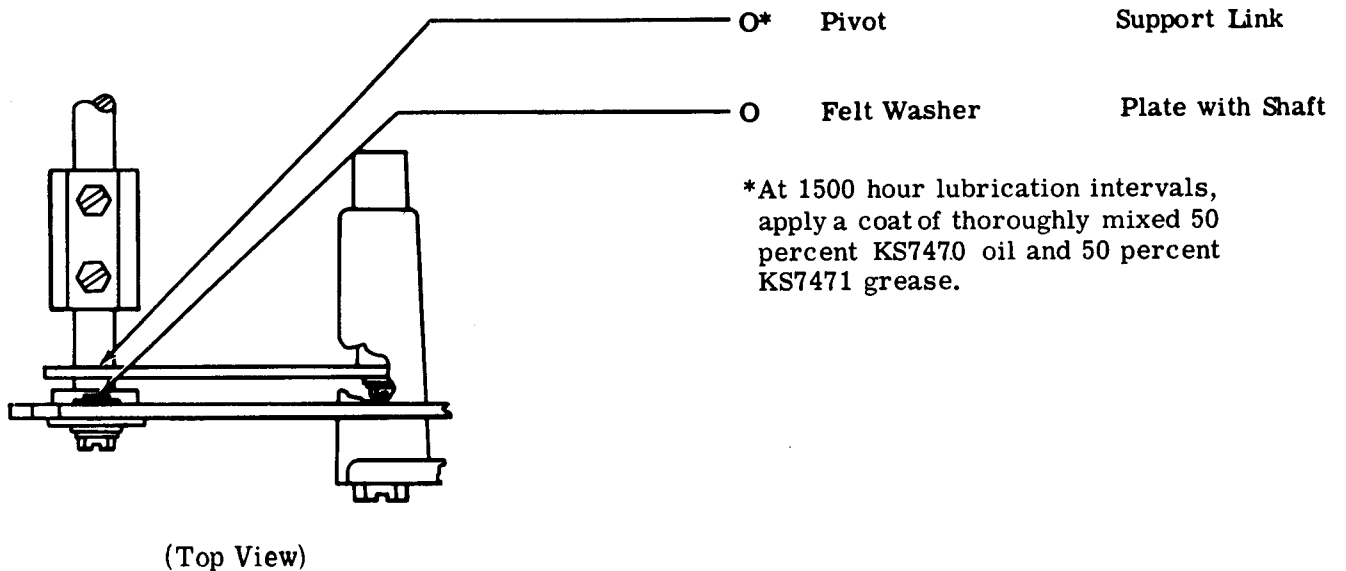

*At 1500 hour lubrication intervals, apply a coat of thoroughly mixed 50 percent KS7470 oil and 50 percent KS7471 grease.

2.05 Tape Punch

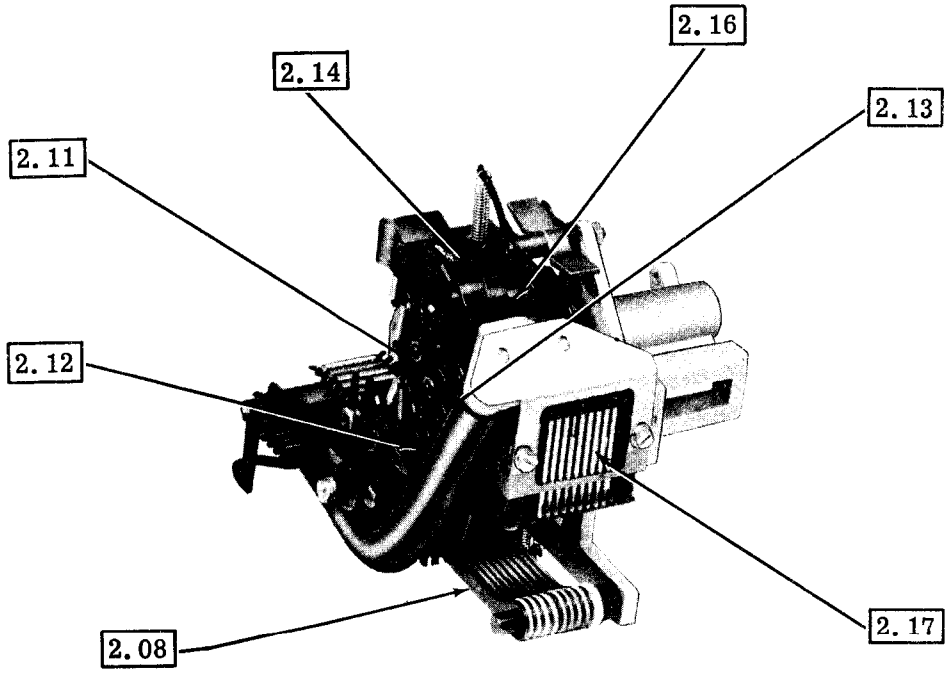

(Left Front View)

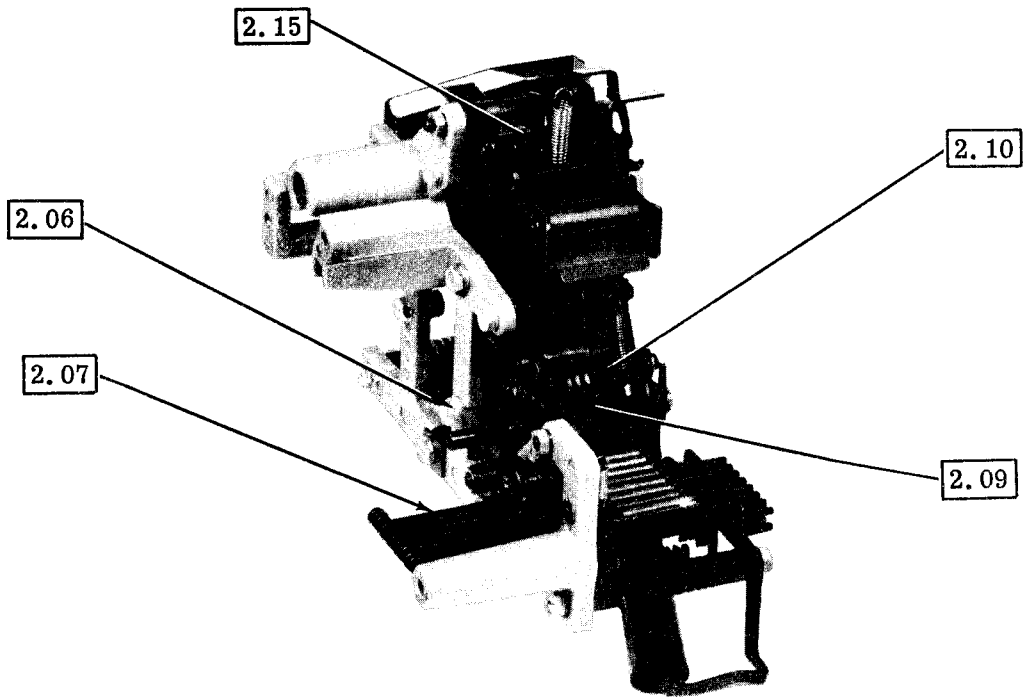

(Right Rear View)

2.06 Control Mechanism

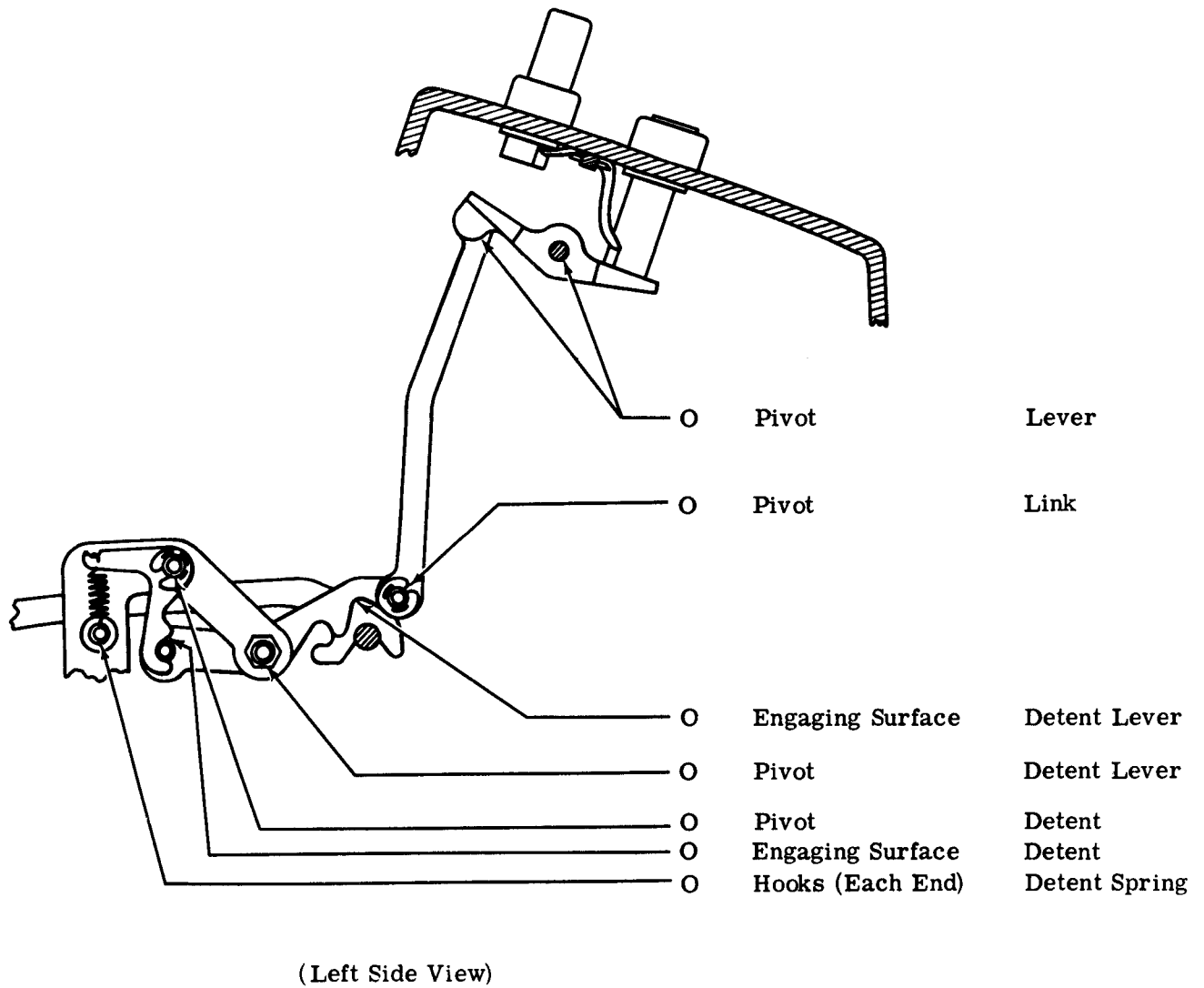

2.07 Codebar Levers

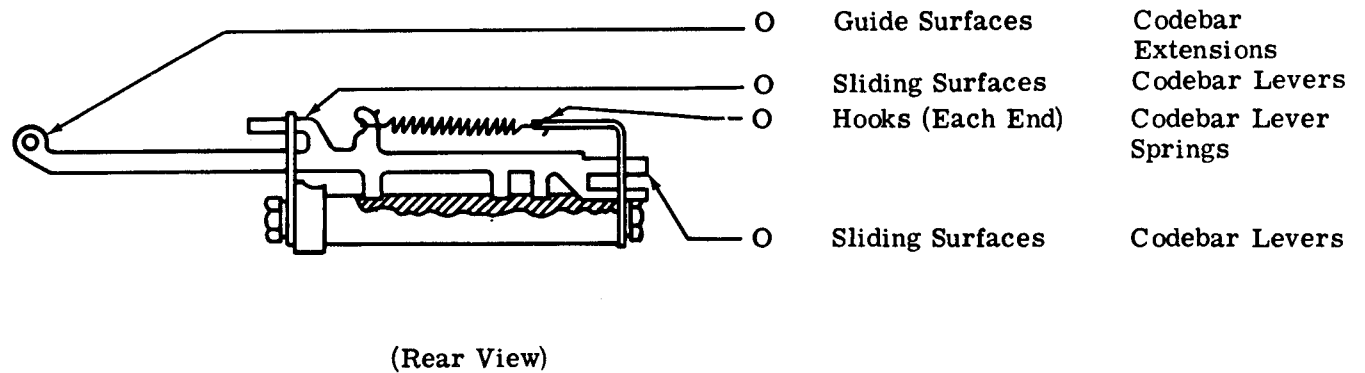

2.08 Sensing Levers

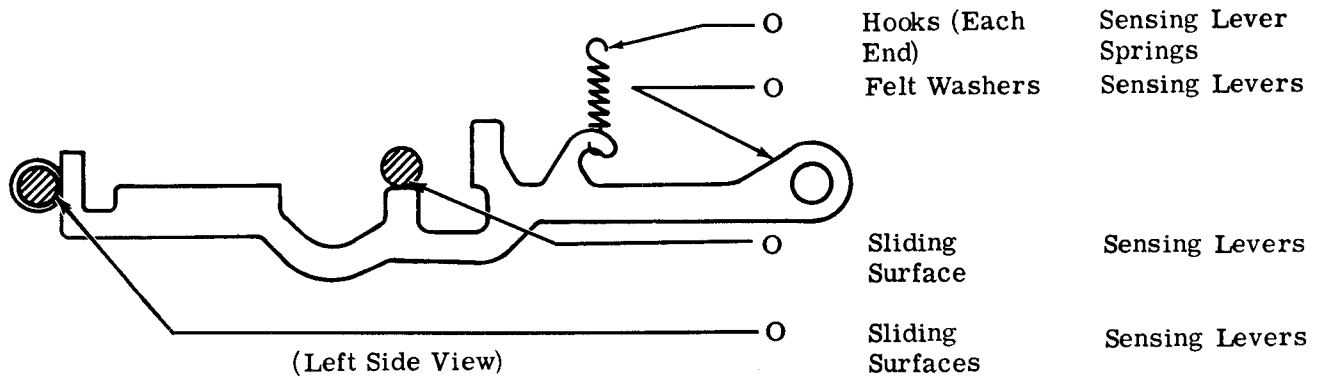

2.09 Stripper Bail

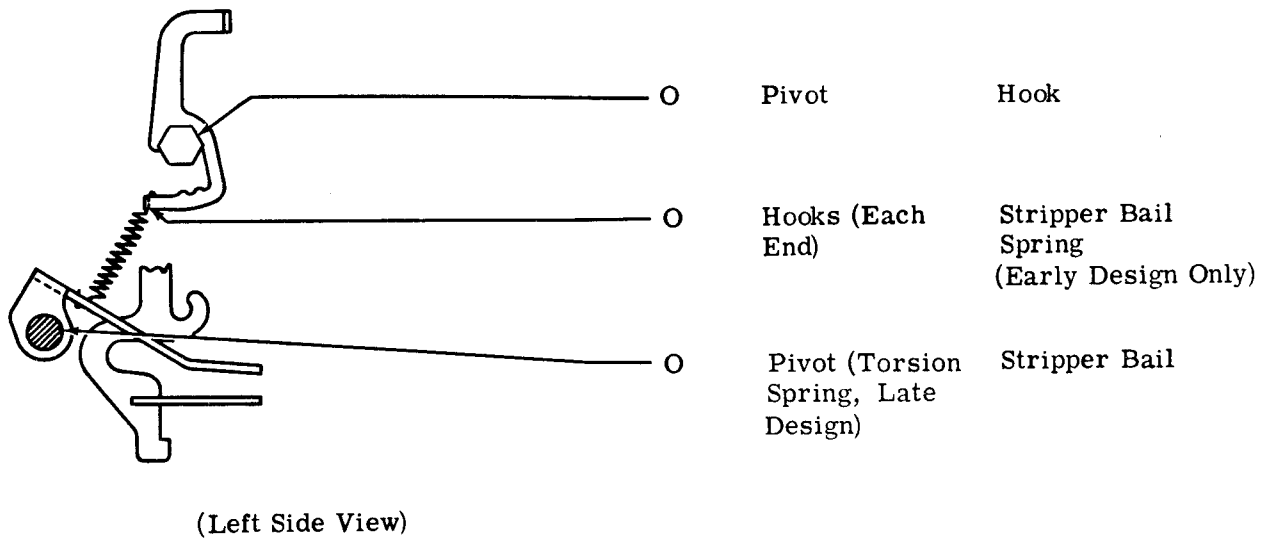

2.10 Pawls and Levers

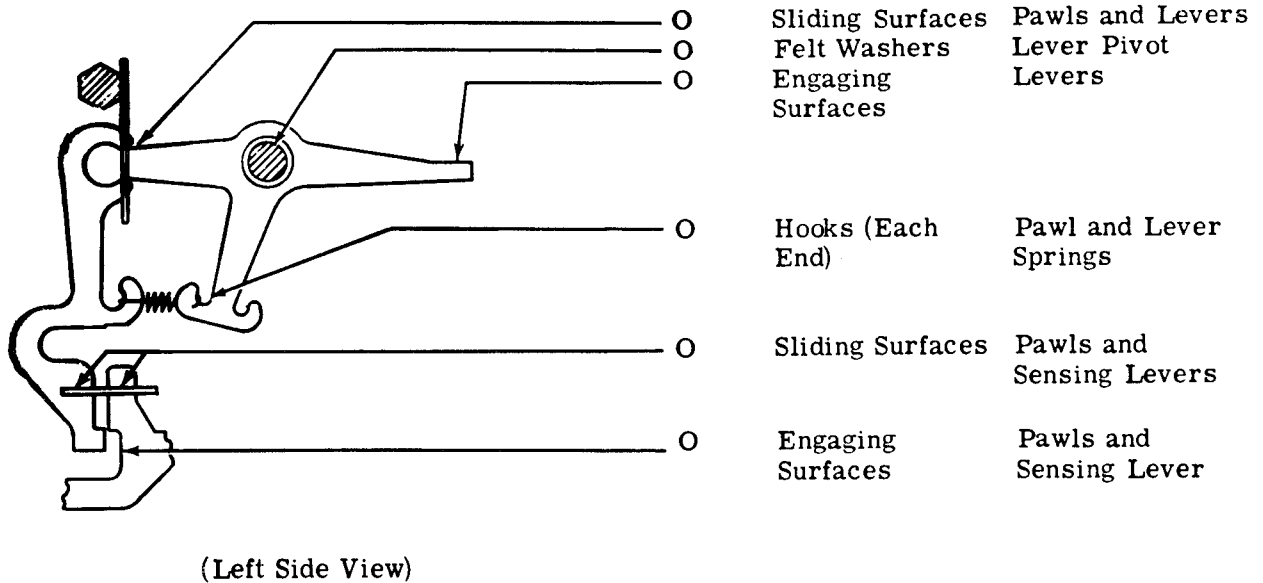

2.11 Feed Mechanism

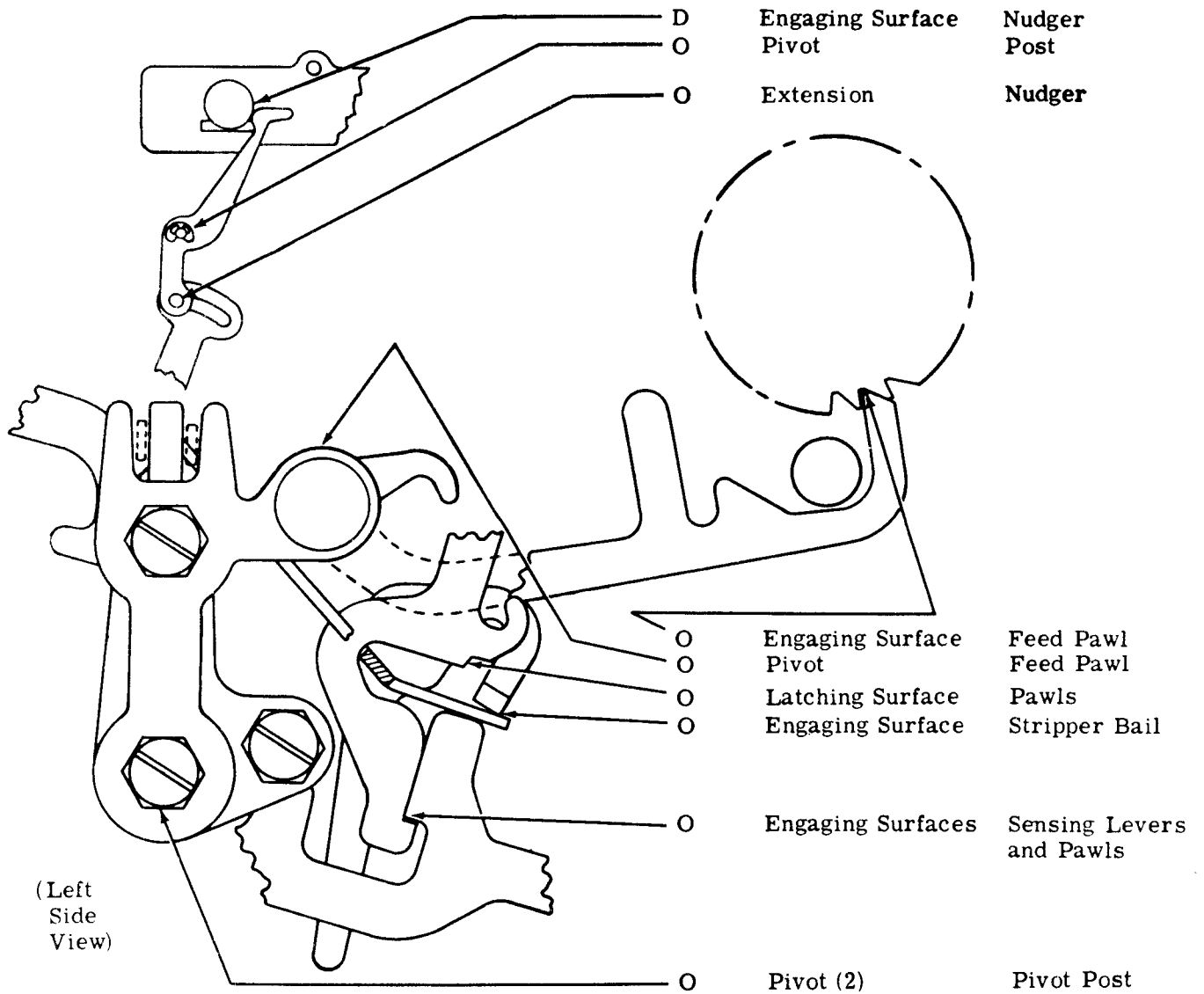

2.12 Feed Pawl

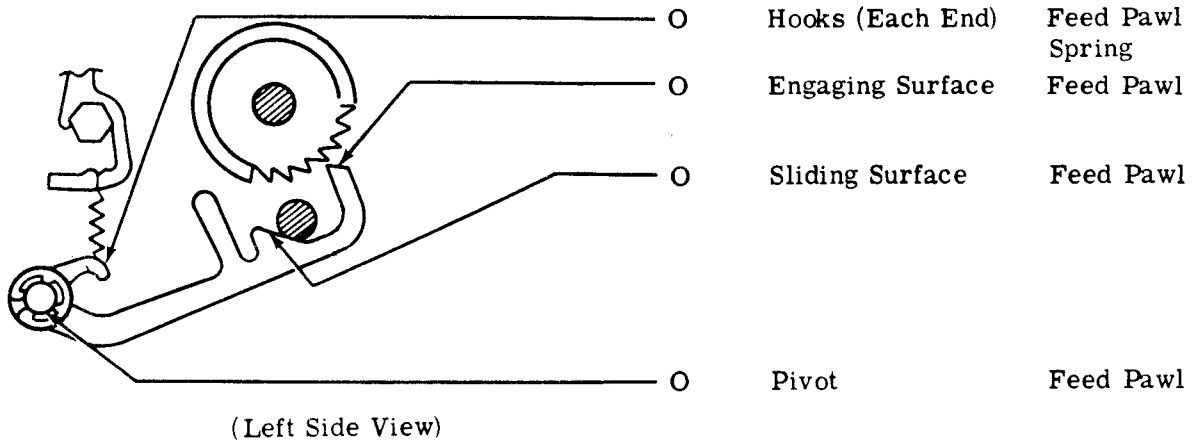

2.13 Detent Lever

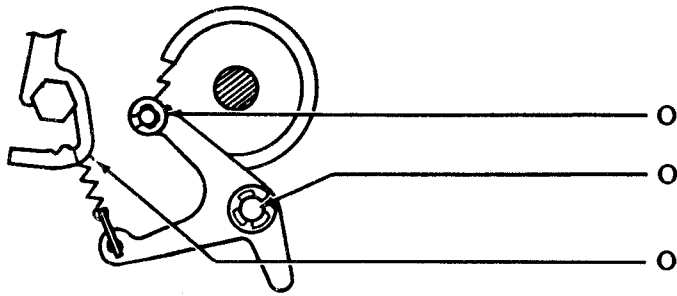

- O Roller Detent Lever
- O Pivot Detent Lever Shaft
- O Hooks (Each End) Detent Lever Spring

(Left Side View)

2.14 Backspace Lever

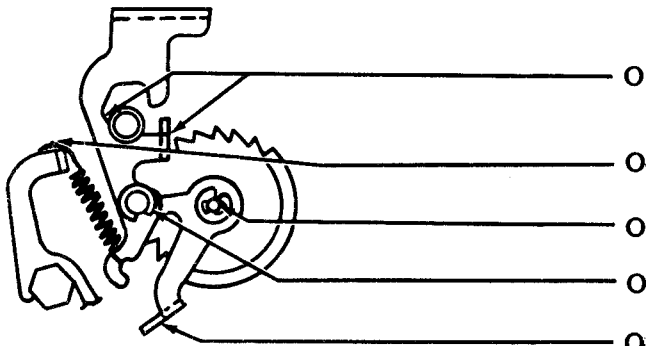

- O Sliding Surface Backspace Lever
- O Hooks (Each End) Backspace Lever Spring
- O Pivot Lever
- O Pivot Lever
- O Engaging Surface Lever Extension

(Left Side View)

2.15 Tape Guide Assembly

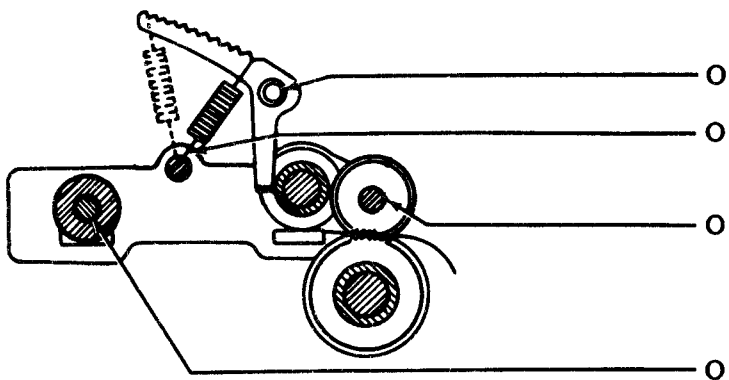

- O Pivot Arm w/Bushing
- O Hooks (Each End) Tape Guide Roller Spring
- O Shaft (Both Ends) Roller
- O Pivots (2) Rear Roller

(Left Side View)

2.16 Tape Guide Roller

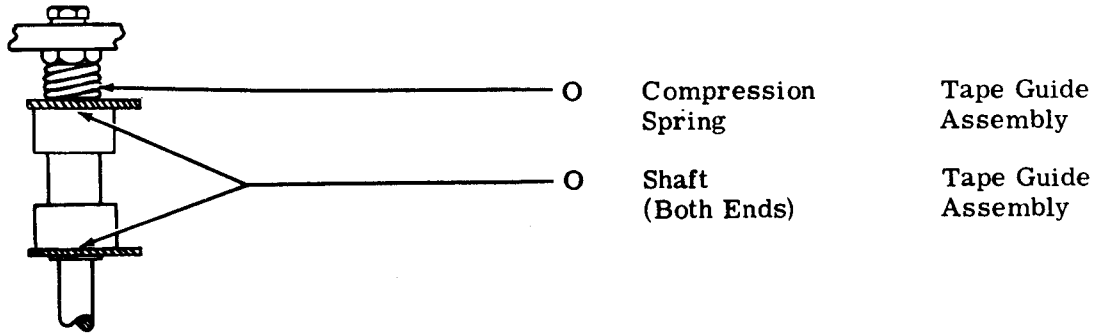

(Top View)

2.17 Punch Block Assembly

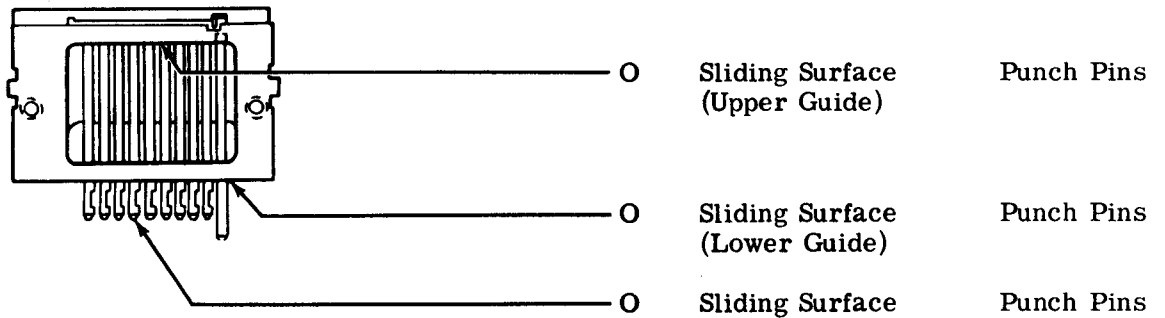

(Front View)

3. VARIATIONS TO THE BASIC UNIT

3.01 Automatic Tape Punch

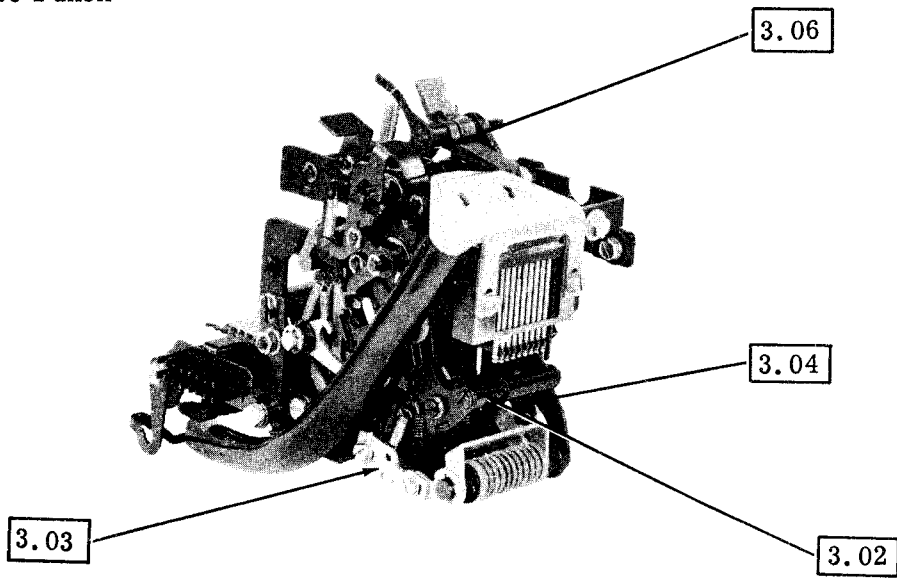

(Left Front View)

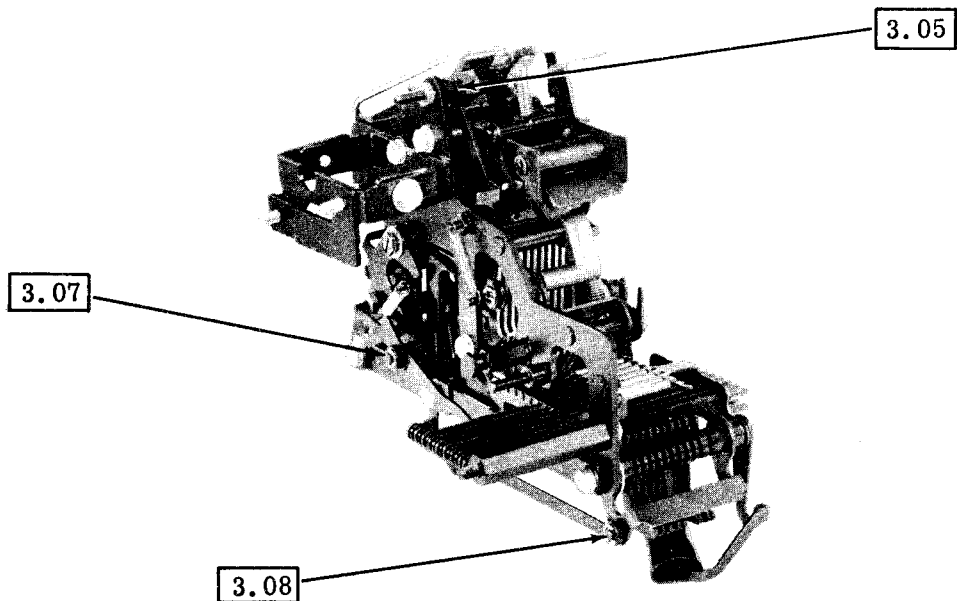

(Right Front View)

3.02 Automatic On-Off Bail Drive Lever

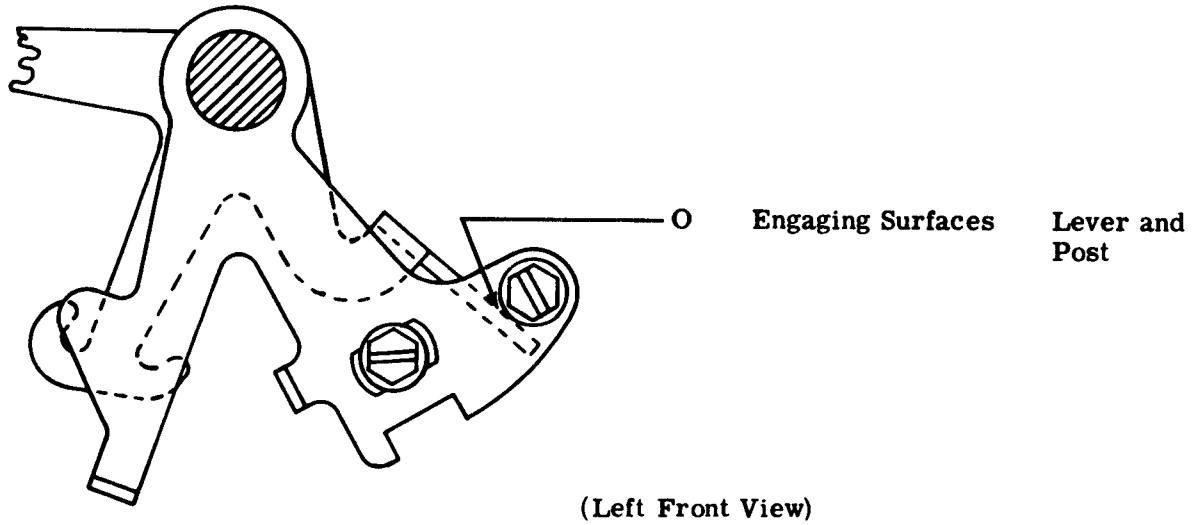

3.03 Automatic On-Off Control Bail

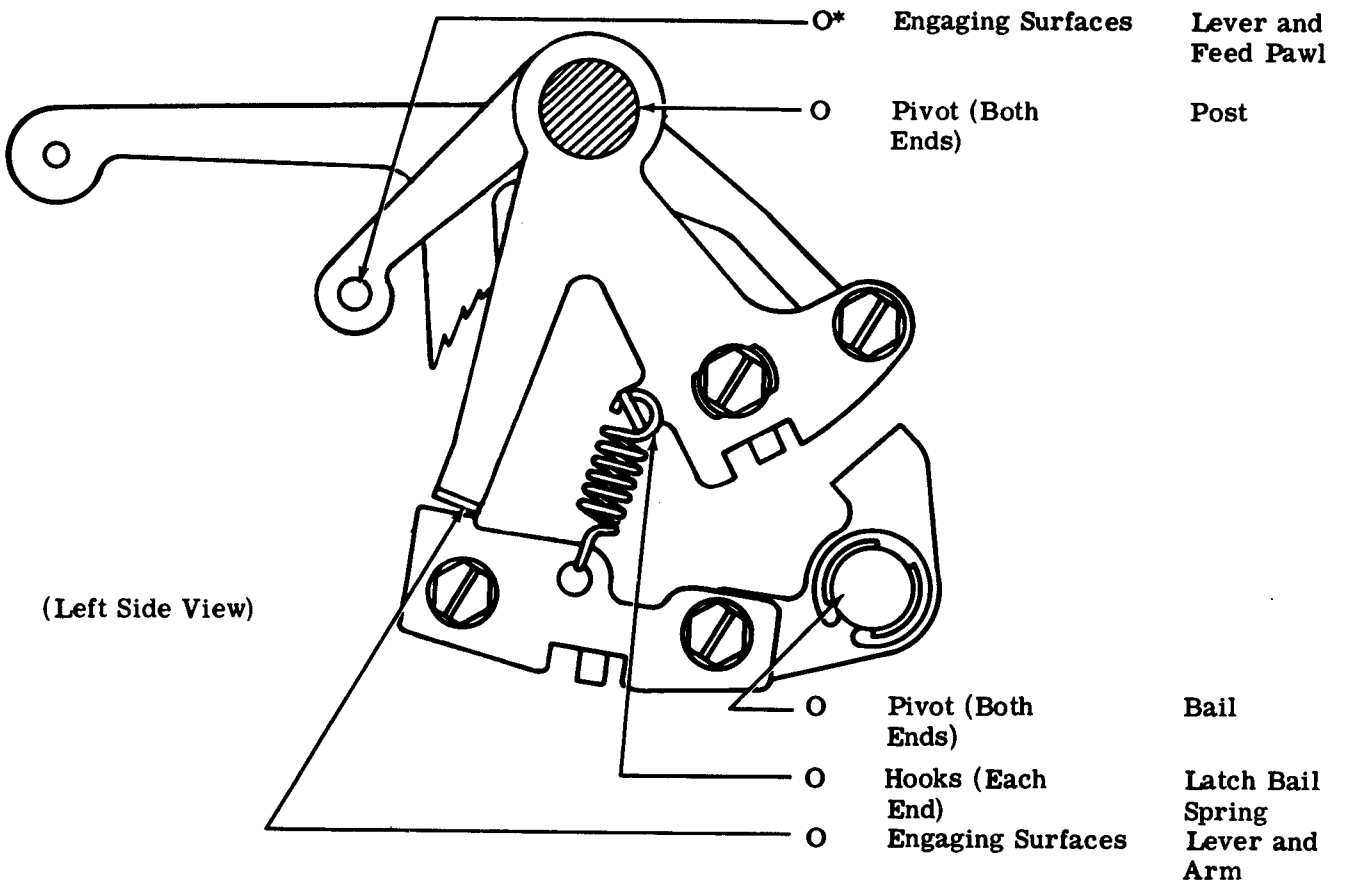

*At 1500 hour lubrication intervals, apply a coat of thoroughly mixed 50 percent KS7470 oil and 50 percent KS7471 grease.

3.04 Automatic On-Off Control Levers

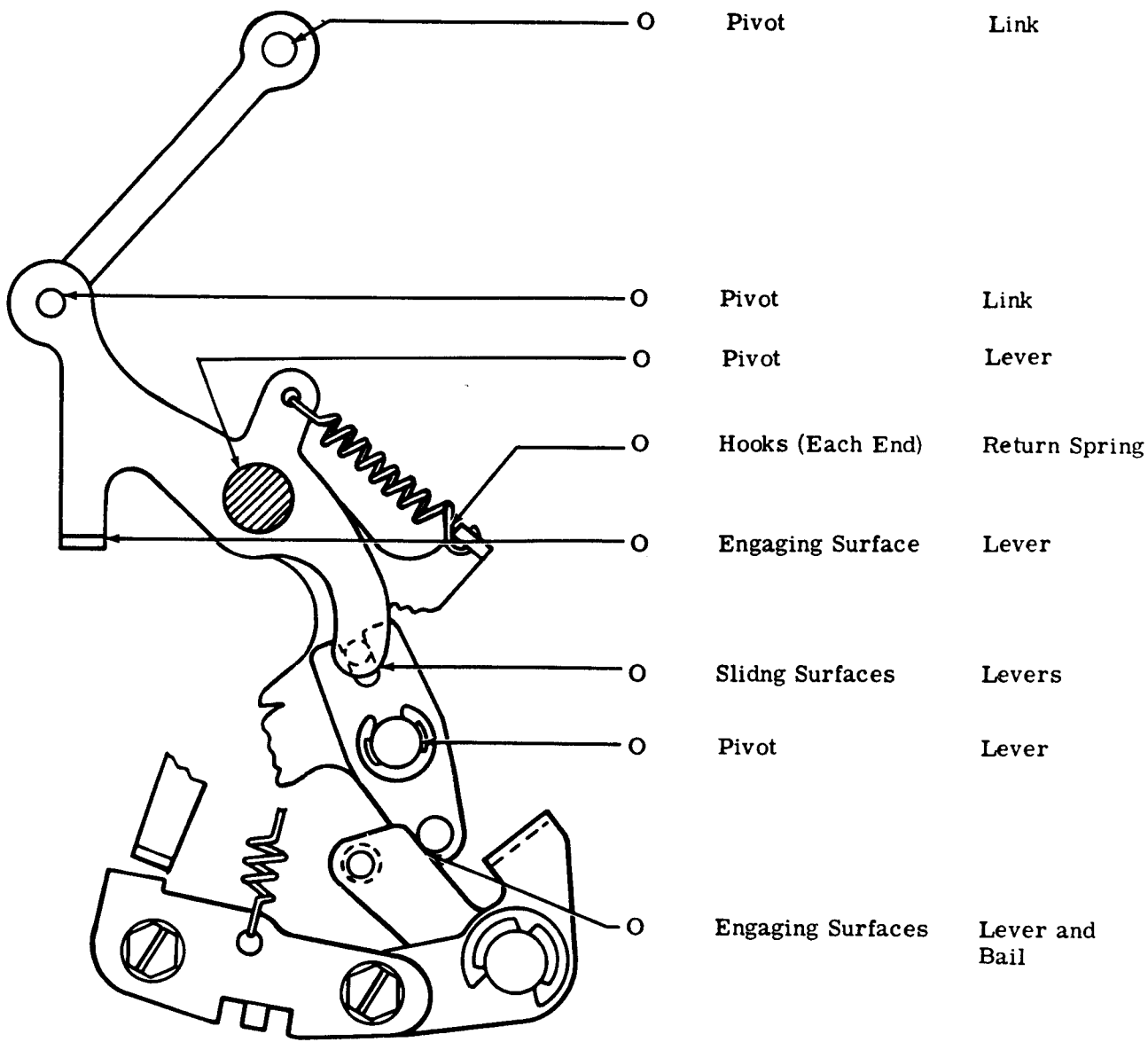

(Left Side View)

3.05 Automatic On-Off Control Mechanisms

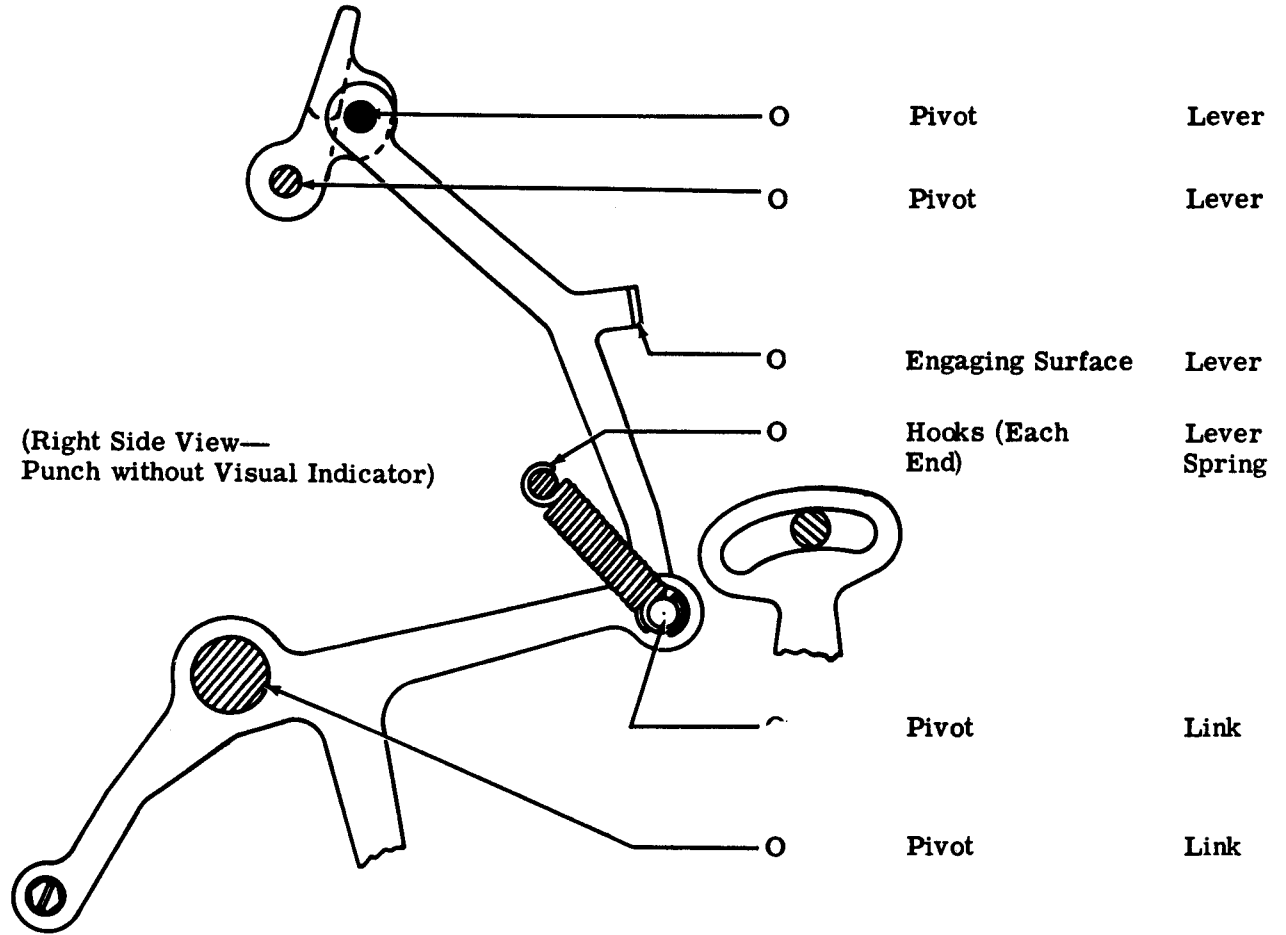

3.06 LOCK "ON" Mechanism

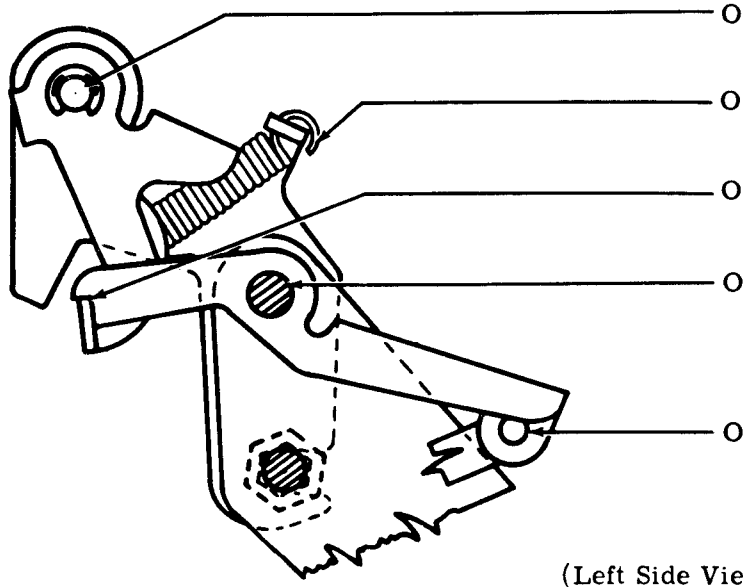

- O Pivot (2) Lock Bail
- O Hook (Each End) Lock Bail Spring
- O Engaging Surfaces Bail and Lever
- O Pivot (2) Lever
- O Pivot Link

(Left Side View)

3.07 Punch Interlock Mechanism

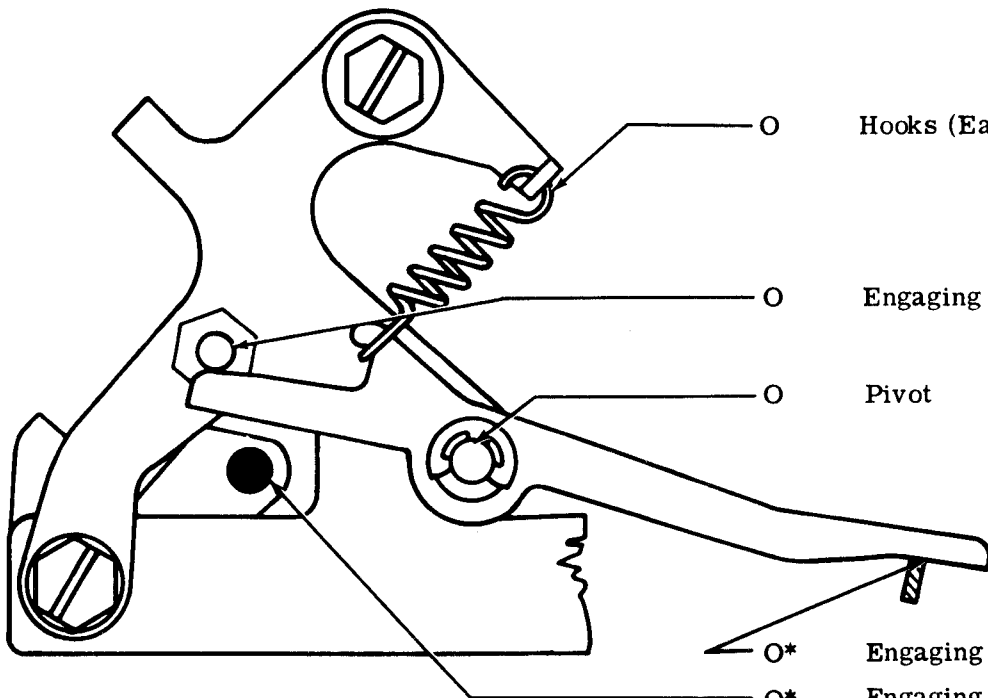

- O Hooks (Each End) Interlock Spring
- O Engaging Surfaces Lever and Post
- O Pivot Lever
- O* Engaging Surfaces Levers
- O* Engaging Surfaces Bail and Lever

(Right Side View)

*At 1500 hour lubrication intervals, apply a coat of thoroughly mixed 50 percent KS7470 oil and 50 percent KS7471 grease.

3.08 Sense Suppression Mechanism

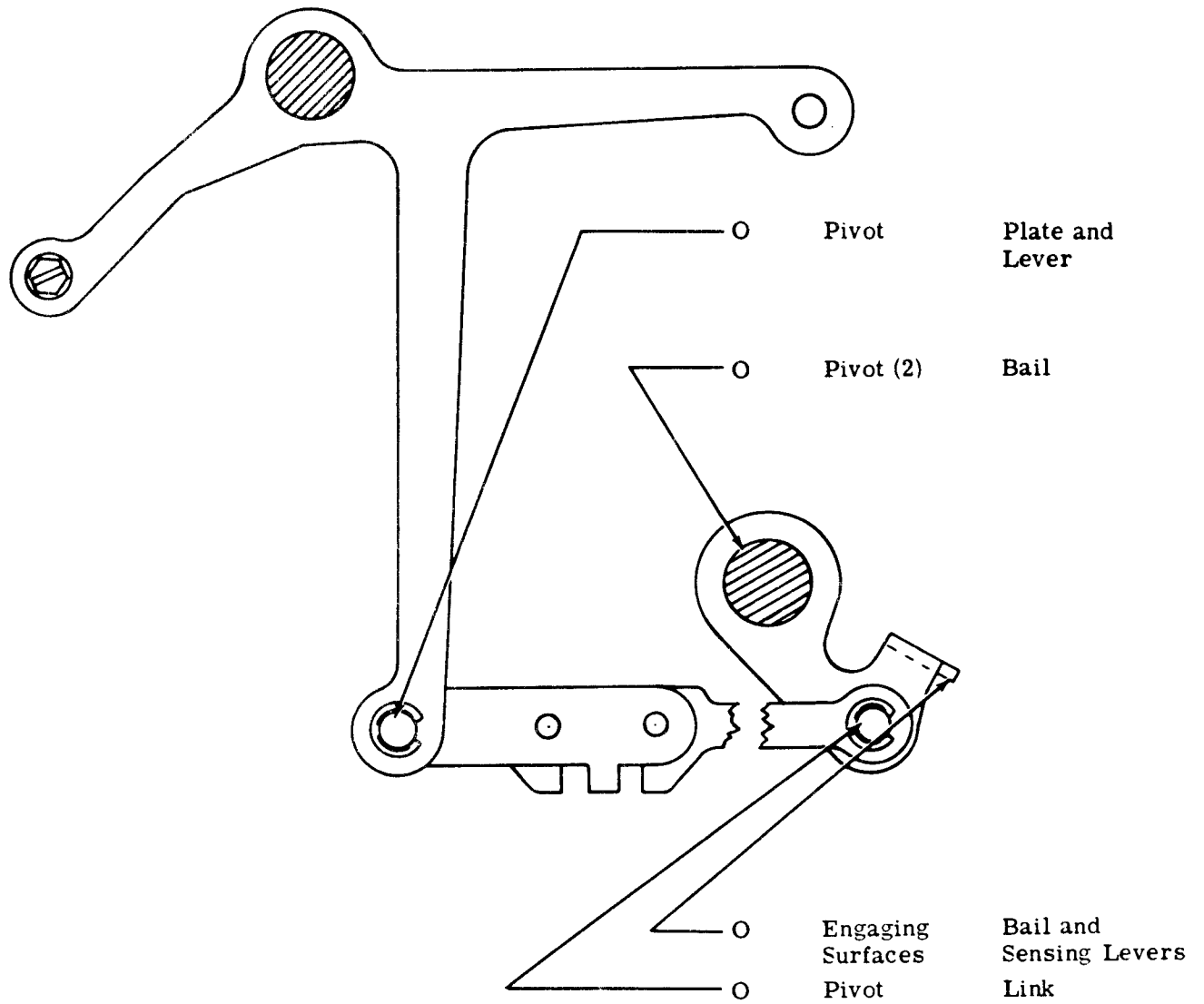

(Right Side View)

4. VARIABLE FEATURE

4.01 Tape Guide for Folded Tape

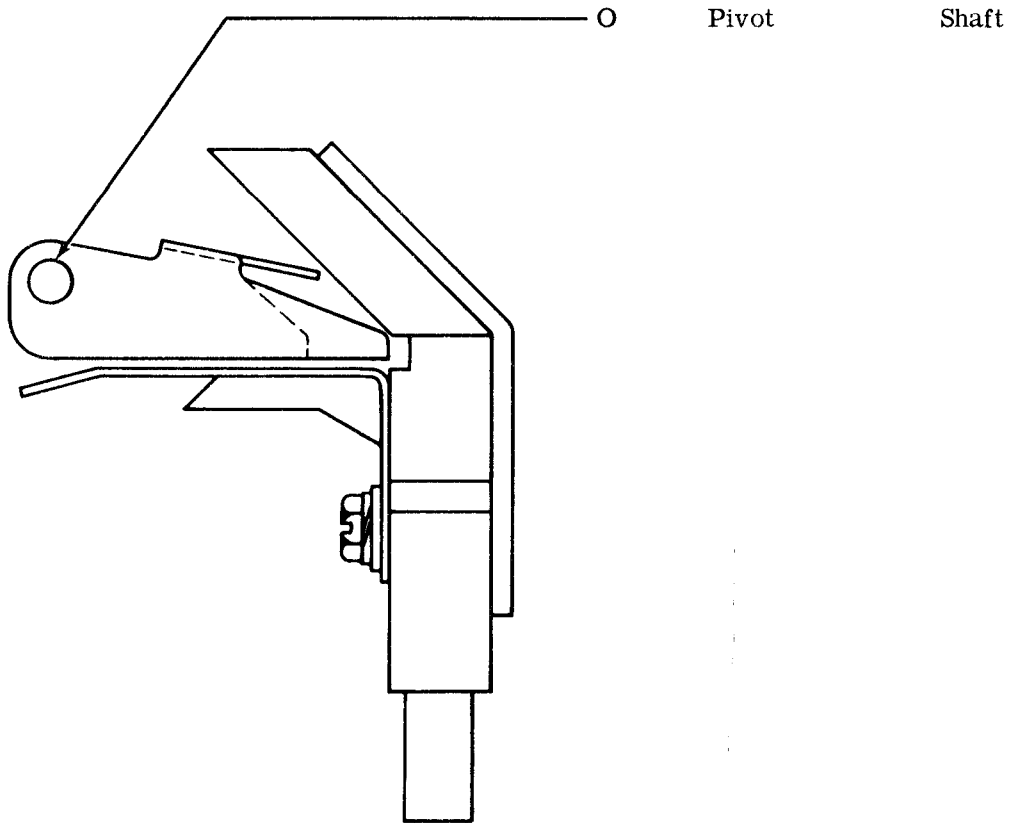

(Left Side View)

33 TAPE PUNCH

DISASSEMBLY AND REASSEMBLY

CONTENTS	PAGE
1. GENERAL.	1
2. DISASSEMBLY AND REASSEMBLY. . .	1
CHAD CHUTE ASSEMBLY.	1
PUNCH BLOCK ASSEMBLY.	2
A. Early Design	2
B. Late Design	2
TAPE GUIDE ASSEMBLY	3
PAWL UPSTOP ASSEMBLY.	3
SENSING LEVERS AND GUIDEPLATE ASSEMBLY.	4
PAWL, LEVER, AND SPRING COMBINATIONS.	4

1. GENERAL

1.01 This section is reissued to incorporate all recent engineering changes and to present disassembly and reassembly information exclusively for the 33 tape punch. Since this is a general revision, marginal arrows, used to indicate changes, have been omitted.

1.02 References to left, right, front, rear, etc, consider the tape punch to be viewed from a position where tape guide assembly faces up and the backspace lever is to the viewer's left. Orientation references in the drive link mechanism area consider the drive link to be up and located to the viewer's right.

1.03 Disassembly, as outlined in this section, covers the procedure for removing the principle subassemblies which make up the unit. If further disassembly is required, refer to Section 574-125-800TC, which shows detailed arrangement of parts. Where it will help in deter-

mining their location, the numbers of the parts are given in the instructions.

1.04 When self-tapping screws are used to mount mechanisms onto castings, do not remove the self-tapping screws. Merely loosen them enough to remove the mechanisms unless specifically instructed otherwise.

1.05 Retaining rings are made of spring steel and have a tendency to release suddenly. To avoid loss of these rings when removing them, proceed as follows.

- (a) Hold retaining ring to prevent its rotating.
- (b) Place blade of screwdriver in one of ring's slots and rotate screwdriver to increase diameter.
- (c) Ring will come off easily in fingers without flying.

1.06 All tools used to remove the mechanisms referred to in this section can be found in the 570-005-800TC standard tool section. No additional special tools are required.

1.07 All damaged, worn, or distorted parts should be replaced if encountered in the disassembly and reassembly procedures.

2. DISASSEMBLY AND REASSEMBLY

Note: For information concerning the proper procedure to remove the tape punch from the set, refer to the set disassembly and reassembly section, 574-100-702TC.

CAUTION: BEFORE BEGINNING DISASSEMBLY, REMOVE CONNECTORS FROM EXTERNAL RECEPTACLES (POWER SOURCE, DATA SET, ETC).

CHAD CHUTE ASSEMBLY

2.01 To remove the chad chute assembly (Figures 1 and 3), proceed as follows.

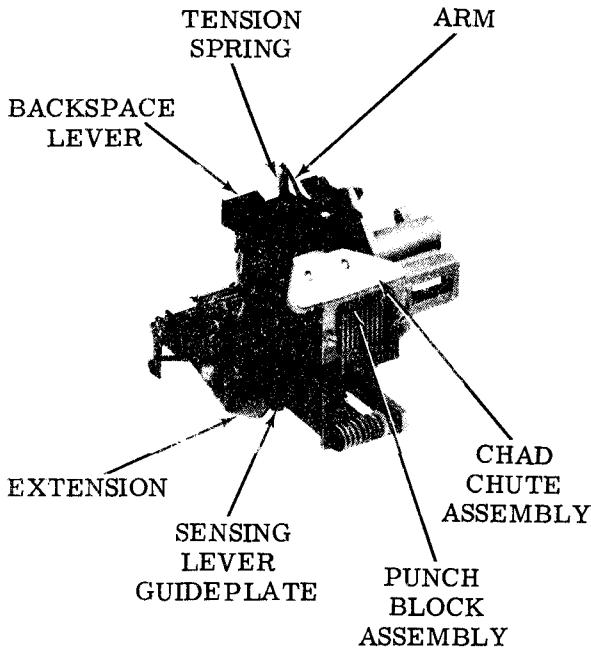

(Left Front View)

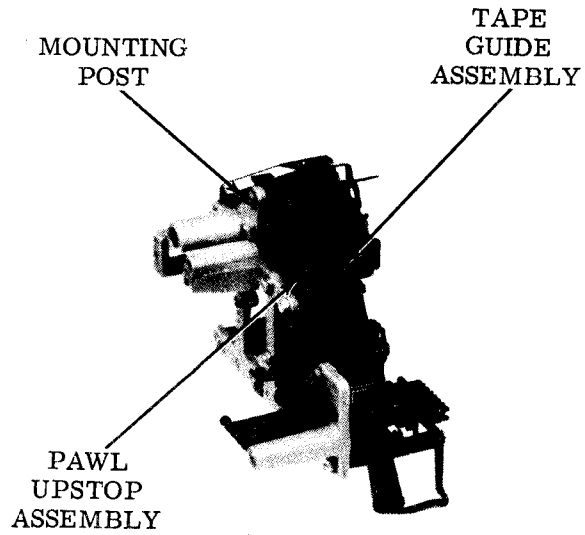

(Right Rear View)

Figure 1 - Tape Punch (Cover Removed, Early Design)

Figure 2 - Tape Punch (Cover Removed, Early Design)

- (a) Remove the TP182915 extension.
- (b) Remove two TP152893 screws, TP110743 lockwashers, and TP2034 flat washers.
- (c) Remove the TP182908 chad chute assembly.
- (d) To replace the chad chute assembly, reverse the procedure used to remove it. Line up the oblong holes of the plate with the holes in the punch block holder. Apply finger pressure on top of the chad chute assembly towards punch block holder when replacing and tightening the two screws.

- (b) Slide the punch block assembly forward until the tongue in the punch block holder and the punch pins disengage the groove in the TP182903 tape punch casting and the TP182813 levers respectively.
- (c) To replace the punch block assembly, position the slots in the punch pins so that they face the guide pin. The bottom of the punch pins should be in line and in a position that approximates their position when on the tape punch. Line up the punch pin slots with their levers and reverse the procedure used to remove the punch block assembly.

Note: Late design units have a TP185891 plastic chad chute assembly that should not be removed.

PUNCH BLOCK ASSEMBLY

A. Early Design

2.02 To remove the punch block assembly (Figure 1), proceed as follows.

- (a) Remove the two TP153817 mounting screws, TP110743 lockwashers, and TP2034 flat washers.

B. Late Design

2.03 To remove punch block assembly (Figures 3 and 4), proceed as follows.

- (a) Remove the three TP153817 screws, TP110743 lockwashers, and TP2034 flat washers.
- (b) Slide the punch block assembly forward until the tongue in the punch block holder and the punch pins disengage the groove in the TP182903 tape punch casting and the TP182813 levers respectively.

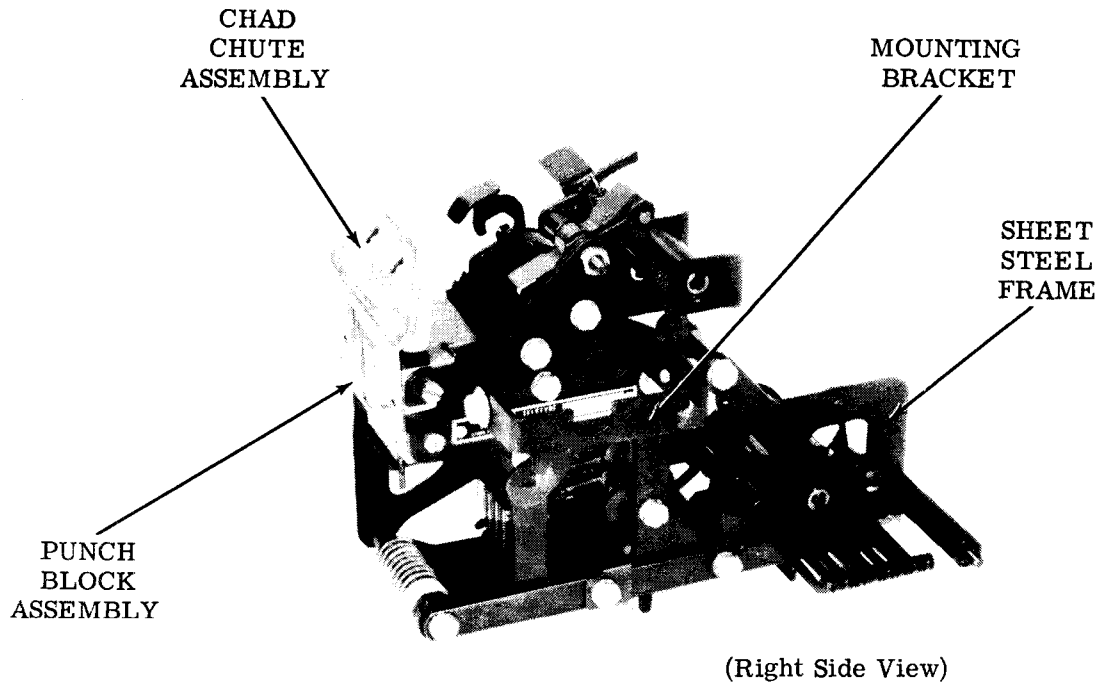

Figure 3 - Tape Punch (Cover Removed, Late Design)

(c) To replace the punch block assembly, position the slots in the punch pins so that they face the guide pin. The bottom of the punch pins should be in line and in a position that approximates their position when on the tape punch. Line up the punch pin slots with their levers and reverse the procedure used to remove the punch block assembly.

TAPE GUIDE ASSEMBLY

2.04 To remove the tape guide assembly (Figures 2 and 4), proceed as follows.

- (a) With a pencil or suitable marking instrument, mark the notch where the TP184095 tension spring end is positioned.
- (b) Unhook the TP184095 tension spring and remove the TP182936 arm from the TP182845 post.
- (c) Remove the TP181244 mounting screw from the tape guide assembly.

(d) Remove the tape guide assembly.

(e) To replace the tape guide assembly, reverse the above procedure making sure that the tension spring is positioned in the marked notch of the arm.

PAWL UPSTOP ASSEMBLY

2.05 To remove the pawl upstop assembly (Figures 2 and 4), proceed as follows.

Note: Never disassemble the pawl upstop assembly prior to removing the pawl, lever, and spring combinations. The slotted TP182822 plate keeps the "ball" and "socket" of the lever and pawl in full engagement.

- (a) Remove the TP181244 screw.
- (b) Remove the TP182821 post, TP182893 bracket, and TP182822 plate.
- (c) To replace the pawl upstop assembly, reverse the procedure used to remove it.

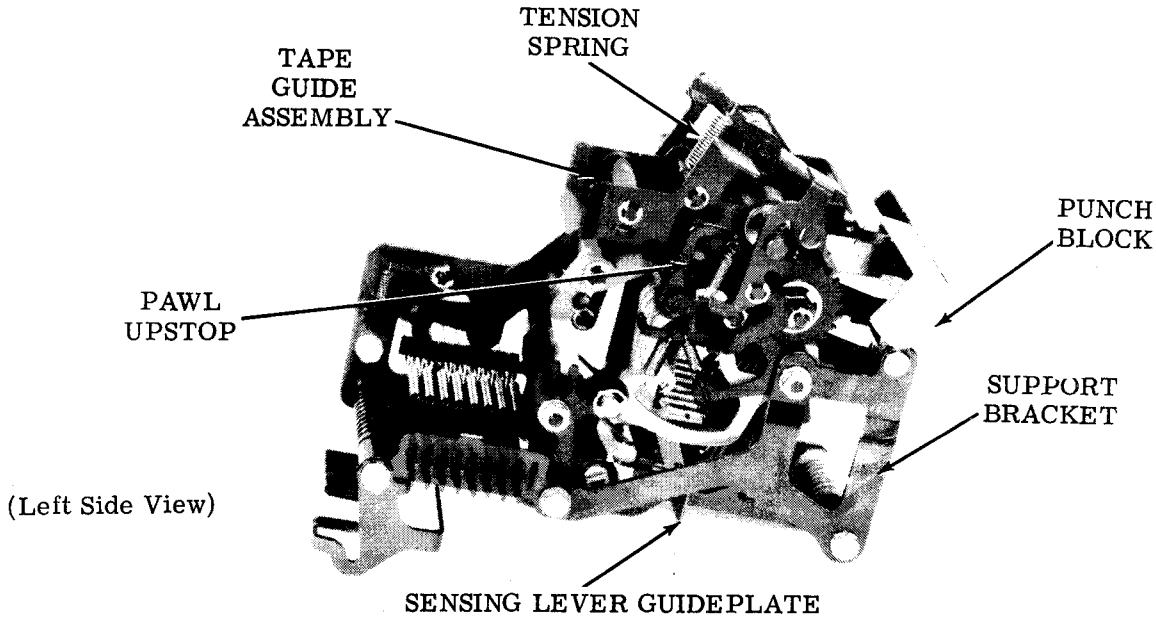

Figure 4 - Tape Punch (Cover Removed, Late Design)

SENSING LEVERS AND GUIDEPLATE ASSEMBLY

2.06 To remove the sensing levers and guideplate assembly (Figures 1 and 4), proceed as follows.

- (a) Unhook each TP182909 sensing lever spring and rotate each sensing lever away from the guideplate.
- (b) Remove the two TP181244 screws from the TP185847 post and remove the post and the attached sensing levers.
- (c) Remove the TP181242 screw and TP3598 nut from the TP182815 guideplate. Remove the guideplate.
- (d) To replace the sensing levers and guideplate, reverse the procedure used to remove them. However, before tightening the TP181242 screw and TP3598 nut, push the guideplate downward to take up all play. Viewing the tape punch from the left, position the guideplate in a horizontal to a slightly counterclockwise from horizontal position as gauged by eye. Then, tighten the TP181242 screw and TP3598 nut.

PAWL, LEVER, AND SPRING COMBINATIONS

2.07 To remove the pawl, lever, and spring combinations (Figure 4), proceed as follows.

- (a) Remove chad chute assembly.
- (b) Remove punch block assembly.
- (c) Remove tape guide assembly.
- (d) Remove pawl upstop assembly.
- (e) Remove sensing levers and guideplate assembly.
- (f) Remove the two TP181244 screws that hold the power bail mechanism in place.
- (g) Remove the TP119652 retaining ring that holds the TP182377 pawl to the power bail assembly.
- (h) Remove the TP7002 flat washer, the TP124177 lockwasher, and the TP3598 nut from the TP185846 post that supplies the pivot point for the levers.
- (i) The pawl, lever, and spring combination and the attached power bail assembly can now be removed from the tape punch.
- (j) To replace the pawl, lever, and spring combination, reverse the procedure used to remove it.

33 COVER

GENERAL DESCRIPTION

CONTENTS	PAGE
1. GENERAL	1
2. DESCRIPTION	1
A. Receive-Only (RO) Cover	1
B. Keyboard Send-Receive (KSR) Cover	1
C. Automatic Send-Receive (ASR) Cover	1

1. GENERAL

1.01 This section is reissued to provide a general description of the 33 cover. Information on the 32 cover presented in Issue 1 has been omitted and is covered in Section 574-176-100TC. Also omitted is information on adjustments, disassembly and reassembly, and lubrication which appeared in Issue 1. This information is now covered in the following sections:

- Disassembly and Reassembly - 574-100-702TC
- Adjustments - 574-126-700TC
- Lubrication - 574-126-701TC

Since this is a general revision marginal arrows have been omitted.

1.02 The main function of the cover is to protect the interior components of the set and serve as a decorative finish to the set. The cover also serves as the frame for the dial, lamps, volume control knob, and the paper supply.

1.03 References to left, right, front, or rear consider the cover as viewed by the operator.

2. DESCRIPTION

A. Receive-Only (RO) Cover

2.01 The RO cover houses the receiving component of the set. The cover is made entirely of plastic.

2.02 A spring detented lid, when raised, provides access to the ribbon. It also allows the operator to easily insert the paper around the platen. A window permits viewing the copy and provides a cutting edge for tearing paper or forms. The entire cover mounts to the set sub-base.

B. Keyboard Send-Receive (KSR) Cover

2.03 The KSR cover illustrated in Figure 1 houses the typing unit, the keyboard, and the call control unit. Like the RO cover, the KSR cover is gray and made of plastic.

2.04 The cover has a raisable lid to provide access to the paper and the ribbon as described in 2.02. In the call control area, the cover has slots for the various lamps, as shown in Figure 1, and an opening for the dial. The nameplate attaches to the front of the cover.

C. Automatic Send-Receive (ASR) Cover

2.05 The ASR cover illustrated in Figure 2 is essentially the same as the KSR except that covers for the tape punch and the tape reader are attached.

2.06 When mounted on the set the cover is one integral whole. The tape punch and the tape reader covers are attached to the main cover and remain as part of the main cover when it is removed. In the particular cover shown in Figure 2, a paper alarm is mounted to the rear of the cover beyond where the paper roll would be mounted. Like the RO and KSR covers, the ASR cover is also gray and plastic.

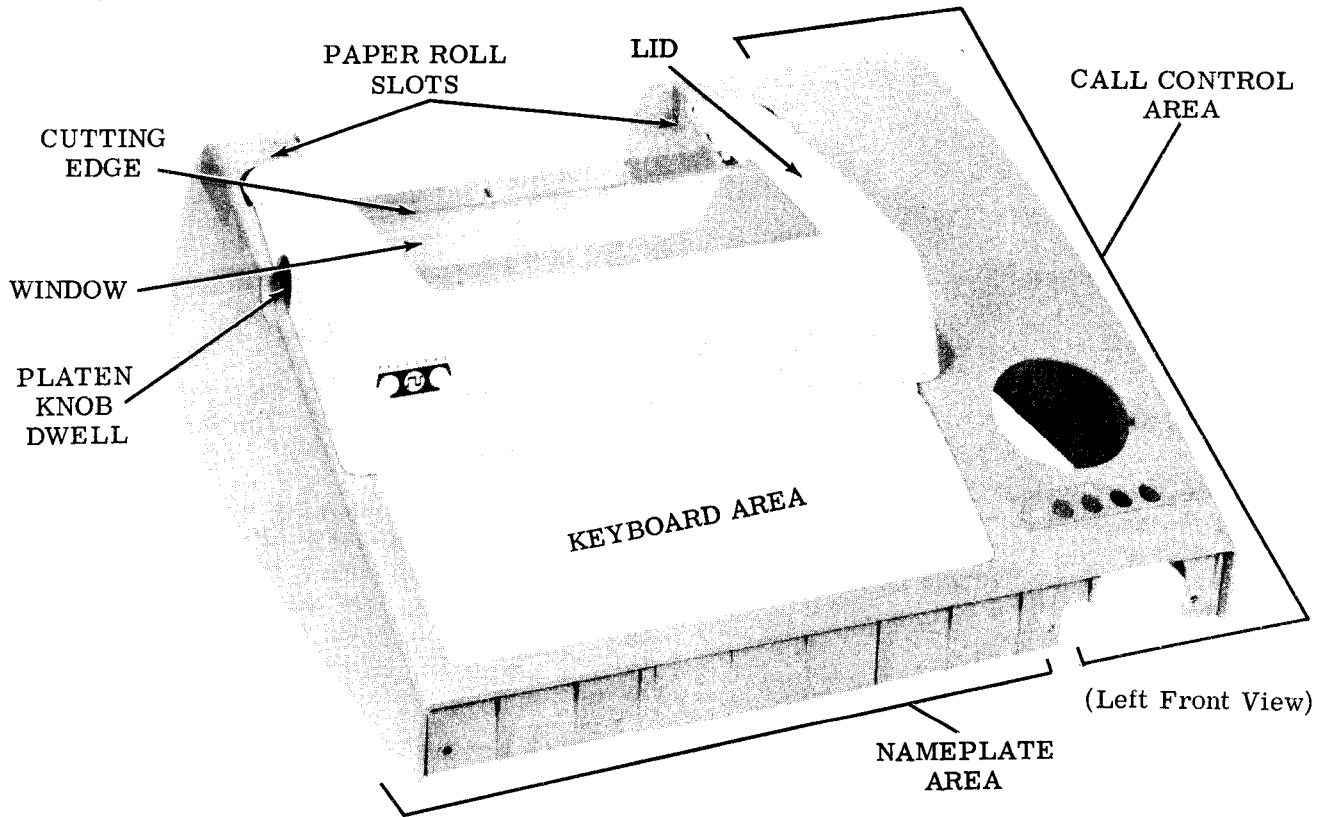

Figure 1 - Keyboard Send-Receive (KSR) Cover

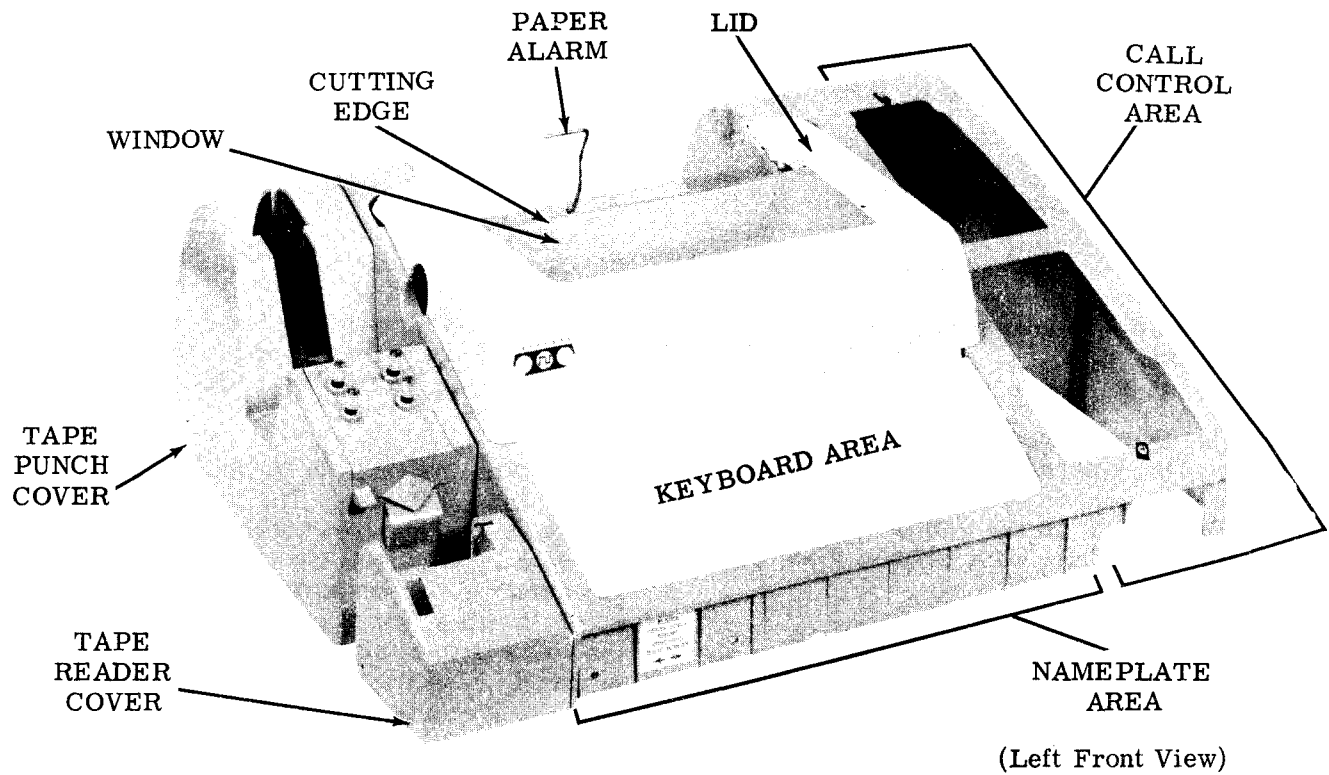

Figure 2 - Automatic Send-Receive (ASR) Cover

33 COVER

LUBRICATION

CONTENTS	PAGE
1. GENERAL.....	1
2. COVER.....	2
ASR Cover.....	2
Lid.....	2

lubricate the cover at regular unit lubrication intervals.

1.05 The textual instructions that accompany the line drawing consist of abbreviated directions, specific lubrication points, and parts affected. The meanings of the abbreviated directions (symbols) are given below:

1. GENERAL

1.01 This section provides lubrication information for the 33 cover formerly covered in Section 574-126-100TC.

1.02 The general lubrication area is shown in the automatic send-receive (ASR) cover photograph. Lubrication requirements are the same for both the keyboard send-receive (KSR) (not illustrated) and the ASR covers. The specific lubrication points are indicated on a line drawing with appropriate textual instructions keyed to the photograph by paragraph number.

1.03 Provide a thorough coat of lubricant at each designated area. Do not overlubricate to the point where lubricant drops onto adjacent parts.

1.04 Lubricate the cover before placing it into service or prior to storage. After a short period of service, relubricate it to make sure that no areas have been missed. Thereafter,

Symbol

Meaning

D

Keep dry — no lubricant permitted.

O

Oil (KS7470)

CAUTION: DO NOT USE ALCOHOL, MINERAL SPIRITS, OR OTHER SOLVENTS TO CLEAN ANY PLASTIC PARTS OR PARTS WITH PROTECTIVE DECORATIVE FINISHES. NORMALLY, A SOFT, DRY CLOTH SHOULD BE USED TO REMOVE DUST, OIL, GREASE, OR OTHERWISE CLEAN PARTS OR SUBASSEMBLIES. IF NECESSARY, A SOFT DAMP CLOTH WITH SOAP OR A MILD DETERGENT MAY BE USED. AFTERWARDS, RINSE EACH CLEANED PART OR SUBASSEMBLY WITH A SOFT, DAMP CLOTH, AND BUFF WITH A SOFT, DRY CLOTH.

1.06 Tools and materials needed for lubrication are listed in Section 570-005-800TC.

1.07 For disassembly and reassembly information, refer to Section 574-126-702TC.

2. COVER

2.01 ASR Cover

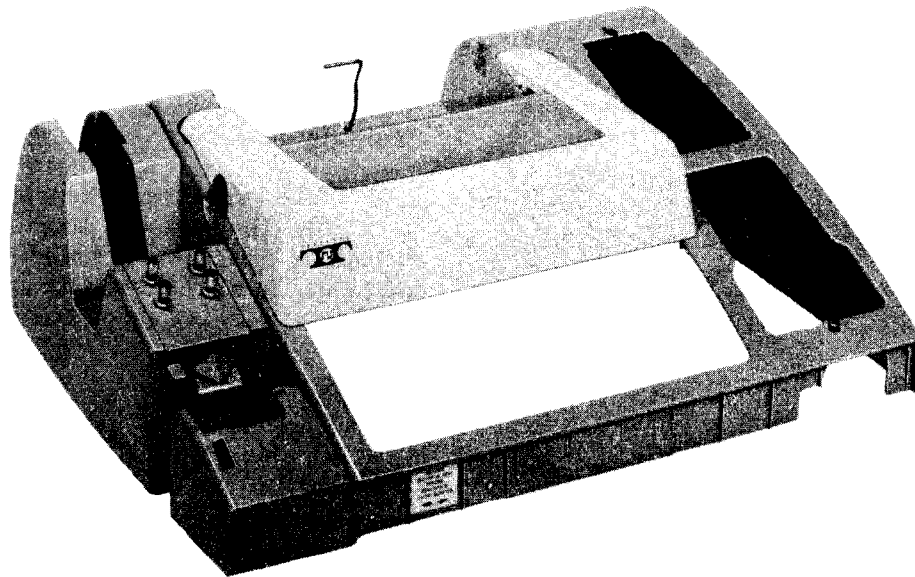

2.02 Lid

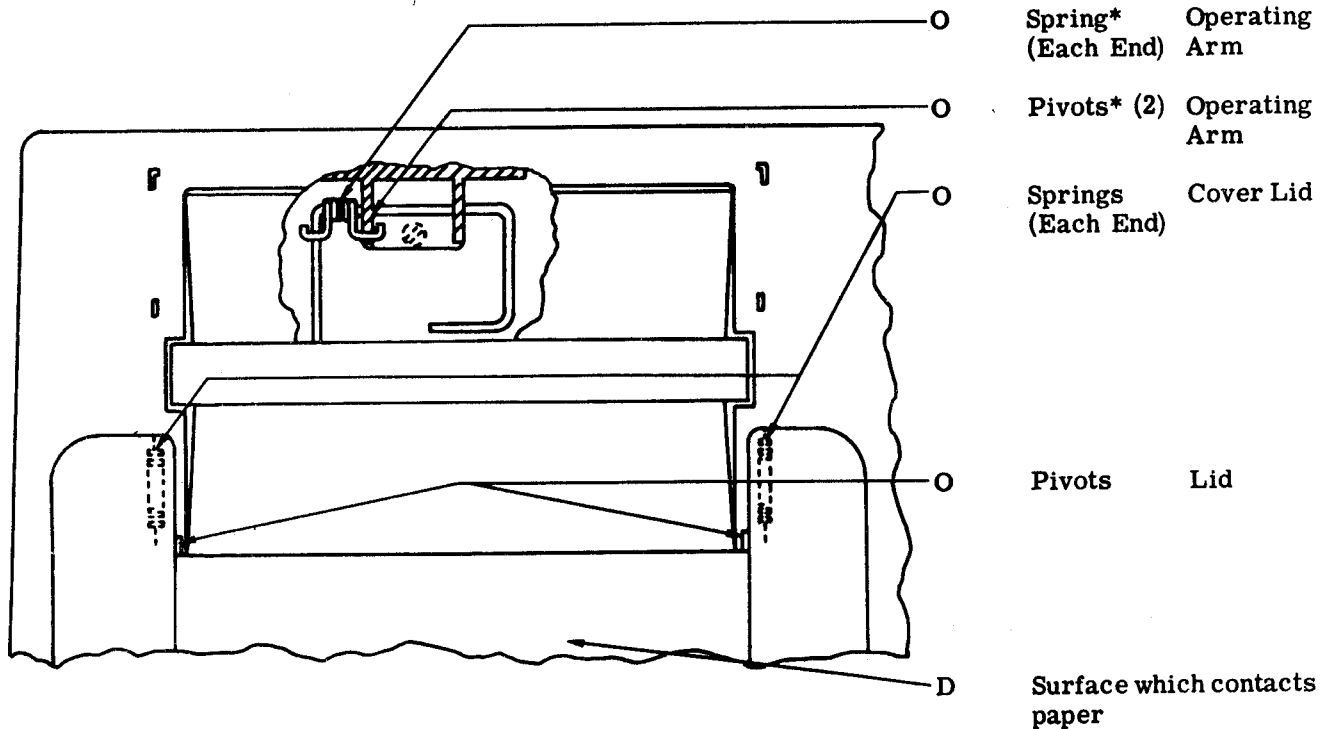

(Top View)

*For covers equipped with TP181441 switch only.