

33 TYPING UNIT  
DISASSEMBLY AND REASSEMBLY

CONTENTS	PAGE	1. GENERAL
1. GENERAL . . . . .	1	1.01 This section provides disassembly and reassembly information for the 33 typing unit. It is reissued to include instructions concerning the downstop bracket for the form-out mechanism on sprocket feed units. Marginal arrows indicate additions and changes.
2. DISASSEMBLY AND REASSEMBLY . .	2	
RIBBON MECHANISM . . . . .	2	
CARRIAGE MECHANISM . . . . .	2	1.02 References to left, right, front, rear, etc, consider the typing unit to be viewed from a position where the ribbon mechanism faces up and the selector mechanism is located to the viewer's left.
CARRIAGE DRIVE BAIL . . . . .	3	
CODEBAR MECHANISM . . . . .	4	
CODEBAR RESET BAIL . . . . .	4	1.03 The disassembly procedure given in this section divides the typing unit into its major assemblies and mechanisms. If further disassembly is required, refer to the appropriate illustrated parts section which shows detailed arrangements of parts. Where it will help in determining location, the numbers of the parts are given in the instructions.
SPACING PAWL MECHANISM . . . . .	4	
FUNCTION LEVER MECHANISM . . . .	5	
SPACING DRUM MECHANISM . . . . .	5	
DISTRIBUTOR TRIP SHAFT MECHANISM . . . . .	5	<b>CAUTION: BEFORE BEGINNING DISASSEMBLY, REMOVE CONNECTORS FROM EXTERNAL RECEPTACLES (POWER SOURCE, DATA SET, ETC).</b>
DISTRIBUTOR MECHANISM . . . . .	6	
FUNCTION ROCKER SHAFT MECHANISM . . . . .	7	1.04 Most of the mechanisms are mounted on castings by self-tapping screws. Therefore, to remove the mechanisms, do not remove the screws, merely loosen them unless specifically instructed otherwise.
FUNCTION BOX MECHANISM . . . . .	7	
PLATEN MECHANISM . . . . .	7	
A. Friction Feed . . . . .	7	1.05 Retaining rings are made of spring steel and have a tendency to release suddenly. To avoid loss of these rings when removing them, proceed as follows.
B. Sprocket Feed . . . . .	7	
FORM-OUT MECHANISM . . . . .	7	(a) Hold retaining ring to prevent it from rotating.
TRIP SHAFT MECHANISM . . . . .	9	(b) Place blade of screwdriver in one of the ring's slots and rotate screwdriver to increase diameter.
SELECTOR MECHANISM . . . . .	9	(c) Ring will come off easily in fingers without flying.
MAIN SHAFT MECHANISM . . . . .	10	
MOTOR . . . . .	11	

1.06 All tools used to remove the mechanisms referred to in this section can be found in the 570-005-800TC standard tool section.

1.07 All damaged, worn, or distorted parts should be replaced if encountered in the disassembly and reassembly procedures.

2. DISASSEMBLY AND REASSEMBLY

Note: For information concerning the proper procedure to remove the typing unit from the set, refer to Section 574-100-702TC.

RIBBON MECHANISM

2.01 To remove ribbon mechanism (Figure 1), proceed as follows.

(a) Remove ribbon by removing the two ribbon spools and disengaging the ribbon from the ribbon guide and the TP183324 reverse arm.

(b) Loosen the two TP152893 mounting screws and lift ribbon mechanism from carriage.

(c) To replace ribbon mechanism, reverse procedure used to remove it.

CARRIAGE MECHANISM

2.02 To remove carriage mechanism (Figure 1), proceed as follows.

(a) Unhook carriage return spring from carriage.

(b) Loosen the two TP180798 mounting screws in spacing pulley mounting bracket. Rotate and remove bracket.

(c) Loosen the two TP180798 mounting screws in spacing drum mounting bracket. Remove mounting bracket.

(d) Disengage spacing belt from pulley on spacing drum.

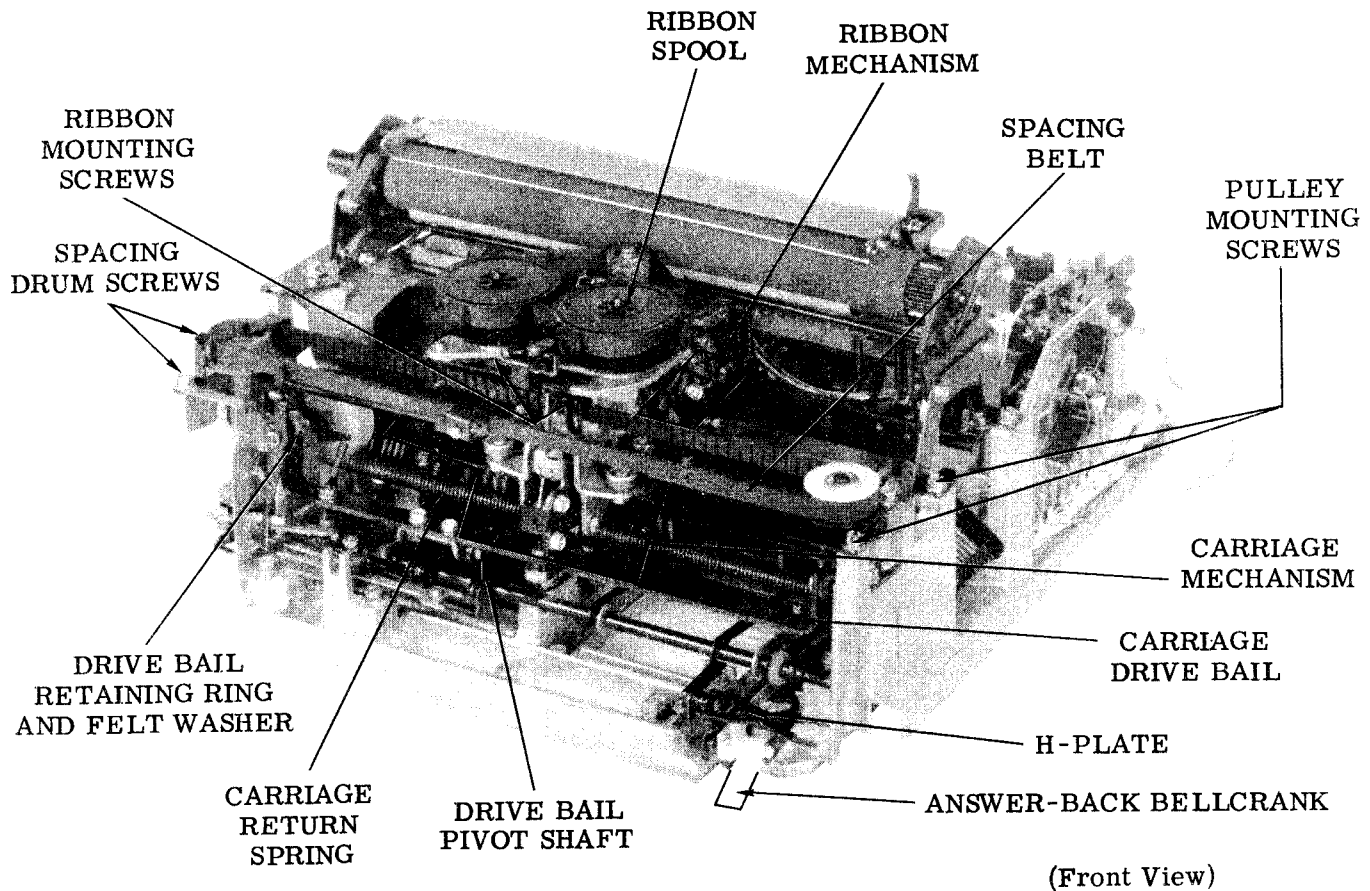

Figure 1 - Typing Unit

- (e) Remove front carriage shaft by sliding it to the right.
- (f) To disengage the rollers from the drive bail, slightly lift the front of the carriage. Rotate the carriage to the left and disengage the slide guides from the codebars.
- (g) Lift the carriage from the unit.
- (h) To replace the carriage mechanism, reverse the procedure used to remove it and observe the following precautions.

- (1) Make sure nylon slide guides engage proper associated codebars.
- (2) Make sure two rear rollers engage carriage rear plate.

**CARRIAGE DRIVE BAIL**

2.03 To remove carriage drive bail (Figures 1 and 2), proceed as follows.

- (a) Remove the carriage mechanism (2.02).

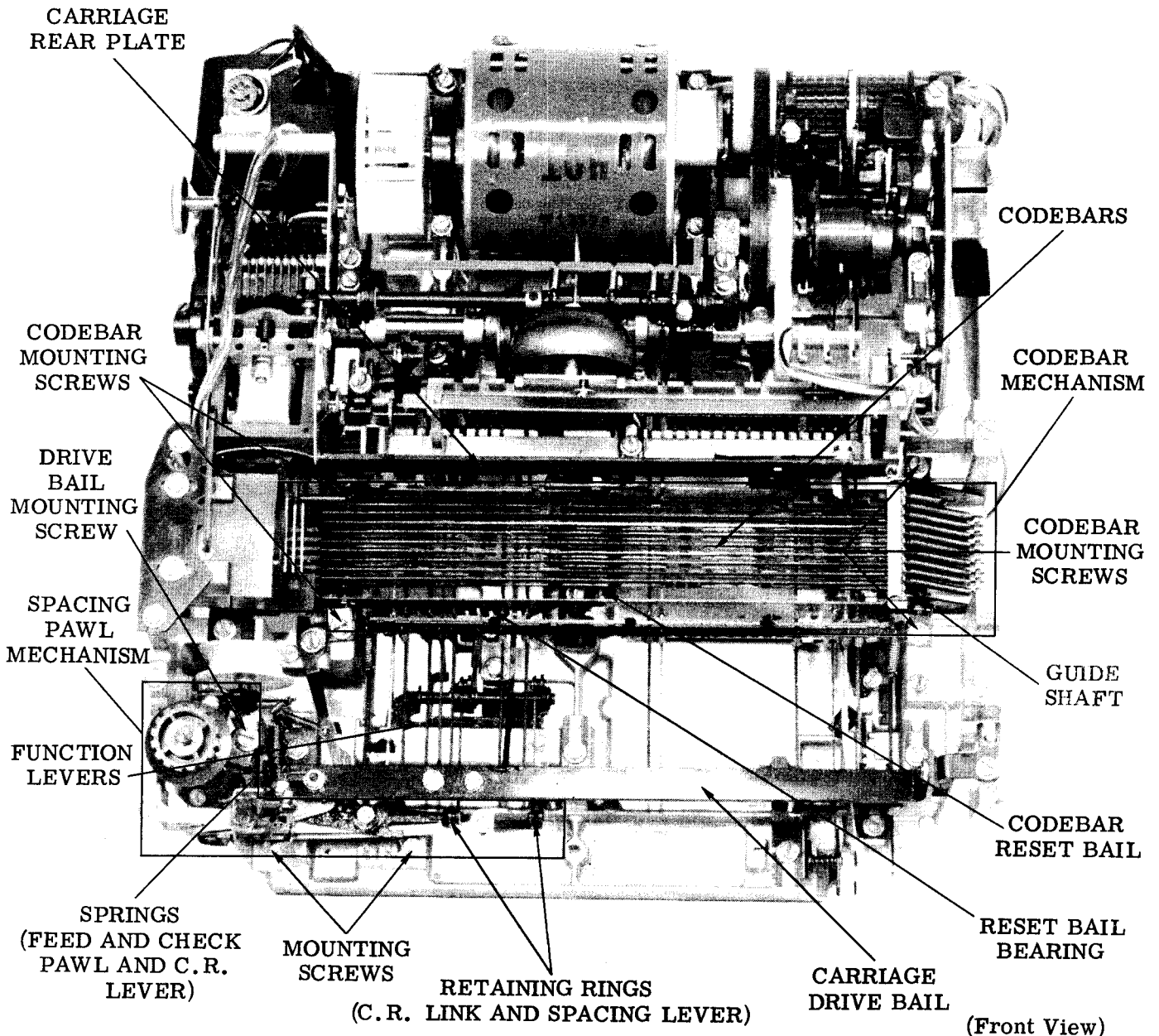

Figure 2 - Typing Unit (Carriage and Platen Removed)

- (b) Remove the TP3598 nut from the TP180546 post.
- (c) Loosen the TP180798 mounting screw and remove the TP181230 clamp plate at left end of carriage drive bail.
- (d) Remove the TP119651 retaining ring and felt washer at right end of bail.
- (e) Remove drive bail by sliding it to left.
- (f) To replace drive bail assembly, reverse procedure used to remove it.

#### CODEBAR MECHANISM

2.04 To remove codebar mechanism (Figure 4), proceed as follows.

- (a) Remove the carriage mechanism (2.02).
- (b) Loosen the TP180798 mounting screw and remove the TP180682 upstop bracket. Tighten the TP180798 mounting screw to secure the TP181230 retaining plate to the base casting.
- (c) Remove the TP180788 carriage rear rail.
- (d) Remove the TP180959 bracket.
- (e) Rotate the main shaft so that the TP180751 lever is positioned on the low part of the codebar cam.
- (f) Loosen the four TP180798 mounting screws and remove the four TP180925 clamps.
- (g) Lift the blocking levers from the guide slots and lift the codebar mechanism from the frame.
- (h) To replace codebar mechanism, reverse procedure used to remove it and observe the following precautions.
  - (1) Make sure function levers are in proper slots in codebars.
  - (2) Make sure codebars reset extensions are to right of TP180928 codebar reset bail and in proper slots of guide.
  - (3) Make sure both right and left TP180920 guide shafts are fully seated in their mountings.

- (4) Make sure the TP181070 space suppression lever is to the left of the TP180947 print suppression codebar.
- (5) Make sure the TP180752 print suppression latch lever fits into slot of the TP180923 bracket mounted on the rear tie bracket.
- (6) Make sure that the left ends of the codebars fully engage their respective blocking lever tines.

#### CODEBAR RESET BAIL

2.05 To remove codebar reset bail (Figures 2 and 3), proceed as follows.

- (a) Remove the codebar spring.
- (b) Remove the TP125252 spring from the TP180773 plate.
- (c) From underside of base casting remove the two TP181245 screws from the two TP180930 bearings.
- (d) Lift the TP180928 codebar reset bail from base casting.
- (e) To replace codebar reset bail, reverse the procedure used to remove it. When replacing the TP181245 screws, make sure that one of them passes through the TP180776 spring bracket before it enters the bearing.

#### SPACING PAWL MECHANISM

2.06 To remove spacing pawl mechanism (Figure 2), proceed as follows.

- (a) Unhook the TP74701 spring from the TP181067 feed pawl, the TP70466 spring from the TP181065 check pawl, and the TP70388 spring from the TP181319 carriage return lever.
- (b) Remove the TP119649 retaining rings from the TP181314 carriage return link and the TP181068 spacing lever.
- (c) Remove carriage mechanism (2.02).
- (d) Remove spacing drum mechanism (2.08).
- (e) Loosen the two TP180798 mounting screws.

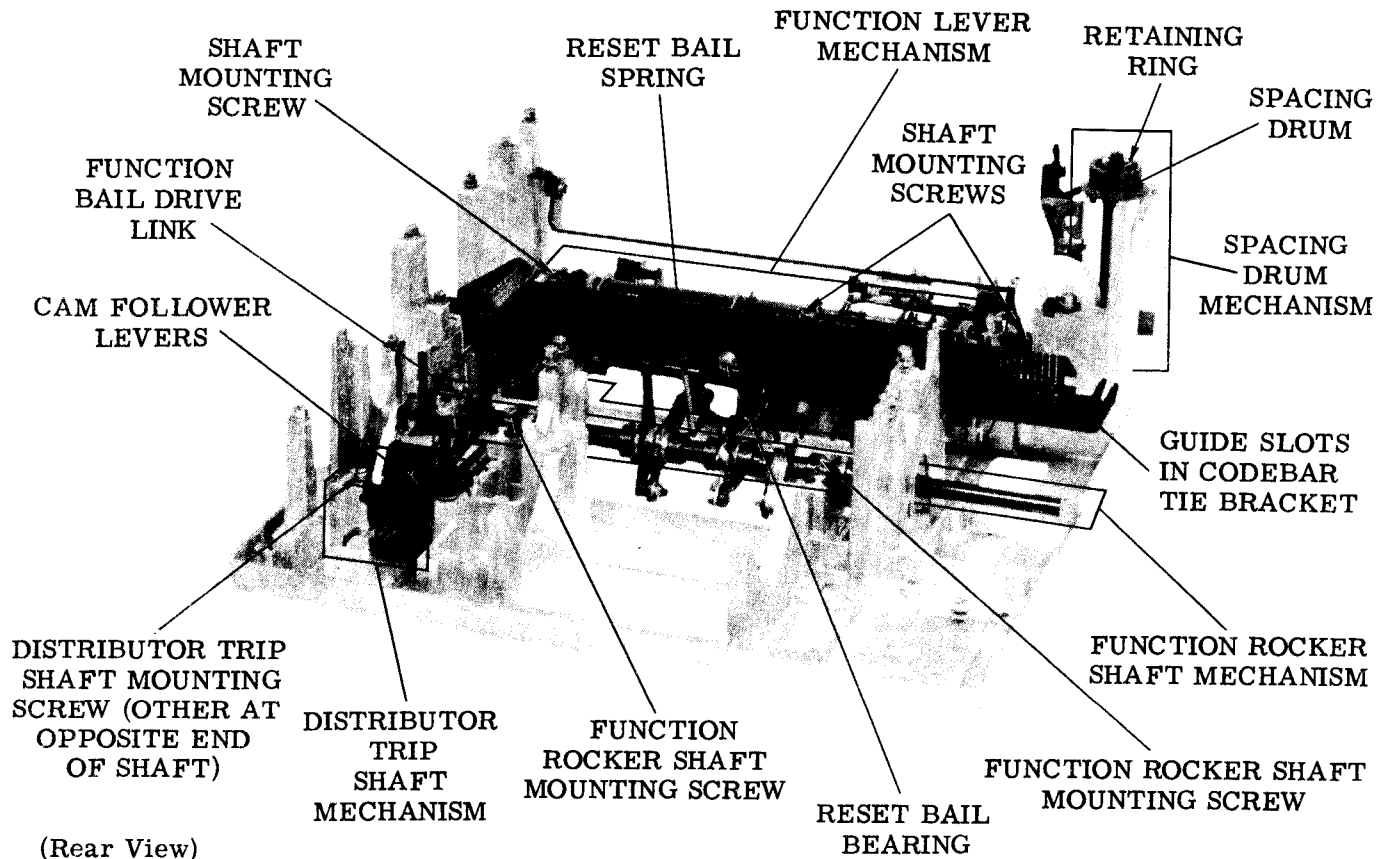

Figure 3 - Typing Unit (A Number of Mechanisms Removed)

- (f) Lift spacing pawl mechanism from base casting.
- (g) To replace spacing pawl mechanism, reverse the procedure used to remove it.

#### FUNCTION LEVER MECHANISM

- 2.07 To remove function lever mechanism (Figure 3), proceed as follows.
- (a) Loosen the three TP180798 mounting screws and rotate levers pivot shaft so flat side is vertical.
  - (b) To remove any function lever, unhook its spring and disengage lever from pivot shaft.
  - (c) To remove levers pivot shaft, remove the two TP180797 clamp plates and the TP180795 spring bracket. Lift out shaft with two drive links attached.
  - (d) To replace function lever mechanism, reverse the procedure used to remove it.

#### SPACING DRUM MECHANISM

- 2.08 To remove spacing drum mechanism (Figure 3), proceed as follows.
- (a) Remove the carriage mechanism (2.02).
  - (b) Remove the TP119653 retaining ring from top of spacing drum and remove drum.
  - (c) From underside of base casting, remove the TP112626 nut and lockwasher from lower end of spacing drum shaft.
  - (d) Lift spacing drum shaft from base casting.
  - (e) To replace spacing drum mechanism, reverse procedure used to remove it.

#### DISTRIBUTOR TRIP SHAFT MECHANISM

- 2.09 To remove distributor trip shaft mechanism (Figure 3), proceed as follows.