

DIGITAL EQUIPMENT CORPORATION
MAYNARD, MASSACHUSETTS

ENGINEERING SPECIFICATION		DATE 10/3/73	
TITLE MR8-F FIELD INSTALLATION AND ACCEPTANCE PROCEDURE			
REVISIONS			
REV	DESCRIPTION	CHG NO	DATE
A	ECO CHANGE	MR8F-00001	1-74
B	UPDATE TO ADD PDF8A	MR8F-00004	12-74
			APPD BY
			DATE
			10/3/73
			12/2/74
			12/2/74

ENG Richard Morris *Richard Morris* APPD *Richard Morris* SIZE CODE A SP NUMBER MR8-F-2 REV B
 DEC FORM NO. DRA 107

This drawing and specifications, herein, are the property of Digital Equipment Corporation and shall not be reproduced or copied or used in whole or in part as the basis for the manufacture or sale of items without written permission.

ENGINEERING SPECIFICATION

ENGINEERING SPECIFICATION		CONTINUATION SHEET	
TITLE MR8-F FIELD INSTALLATION AND ACCEPTANCE PROCEDURE			
1. Shipping Hardware			
1.1 See A-PL-MR8-F-5 (Shipping List)			
2. Shipping Software			
2.1 See A-PL-MR8-F-6 (Software List)			
NOTE: Prom Diagnostics are not used in this Acceptance Procedure. These Maindecs are used to diagnose the MR8-FB after the MR8-FB has been programmed to the customers specifications.			
3. Equipment required for acceptance			
3.1 PDP8E, 8M, or 8A with a programmers console. If 4K of read/write memory is present, the system must have a KMB-E (M837), or KMB-A (M8317), extended memory control. All these options must be customer supplied.			
4. Unpacking and Installation			
4.1 Unpack and inspect the modules for physical damage.			
4.2 Make sure all four top edge connectors on the M8349 are fitted correctly.			
4.3 Turn power off in the PDP8E, 8M, 8F, or 8A.			
4.4 If the MR8-FB is a PDP8E, 8F, or 8M, add-on remove M8330 and insert the new M8330-YB in the same slot. The MR8-FB requires an M8330-YB in order to operate.			
4.5 Insert the M8349 in the OMNIBUS behind the RFI shield (M849) in the PDP8E, 8F, or 8M, and in the lowest available Omnibus slot in the PDP8A.			
4.6 Remove or disable all other options in PDP8E, 8M, 8F, or 8A that use the "SW" or "BOOT" switch option.			

DEC FORM NO. DRA 108
 DEC 15-13811-1022-N370
 SIZE CODE A SP NUMBER MR8-F-2 REV B
 SHEET 2 OF 3

ENGINEERING SPECIFICATION

ENGINEERING SPECIFICATION		CONTINUATION SHEET	
TITLE MR8-F FIELD INSTALLATION AND ACCEPTANCE PROCEDURE			
5. Acceptance			
5.1 The MR8-FB is shipped with Prom Internal test MainDec-08-DIMRE programmed in the Prom chips.			
5.2 Turn PDP8E, 8M, 8F, or 8A, power on.			
5.3 If the MR8-FB is an add-on and an M8330-YB was installed, run all basic 8E diagnostics and EAL diagnostics if applicable.			
5.4 Toggle "SW" or "BOOT" switch. The Prom Internal Test should be running. Refer to MAINDEC-08-DIMRE writeup if there are any errors. With the switch register = 00000 the test will halt in approx. 3 min. Repeat the test 4 times.			
5.5 If no errors have occurred the MR8-FB is ready to be erased and reprogrammed by the customer.			

DEC FORM NO. DRA 108
 DEC 15-13811-1022-N370
 SIZE CODE A SP NUMBER MR8-F-2 REV B
 SHEET 3 OF 3

ENGINEERING SPECIFICATION

ENGINEERING SPECIFICATION		CONTINUATION SHEET	
TITLE MR8-F FIELD INSTALLATION AND ACCEPTANCE PROCEDURE			
5. Acceptance			
5.1 The MR8-FB is shipped with Prom Internal test MainDec-08-DIMRE programmed in the Prom chips.			
5.2 Turn PDP8E, 8M, 8F, or 8A, power on.			
5.3 If the MR8-FB is an add-on and an M8330-YB was installed, run all basic 8E diagnostics and EAL diagnostics if applicable.			
5.4 Toggle "SW" or "BOOT" switch. The Prom Internal Test should be running. Refer to MAINDEC-08-DIMRE writeup if there are any errors. With the switch register = 00000 the test will halt in approx. 3 min. Repeat the test 4 times.			
5.5 If no errors have occurred the MR8-FB is ready to be erased and reprogrammed by the customer.			

DEC FORM NO. DRA 108
 DEC 15-13811-1022-N370
 SIZE CODE A SP NUMBER MR8-F-2 REV B
 SHEET 2 OF 3

THIS DRAWING AND SPECIFICATIONS HEREIN ARE THE PROPERTY OF DIGITAL EQUIPMENT CORPORATION AND SHALL NOT BE REPRODUCED OR COPIED OR USED IN WHOLE OR IN PART AS THE BASIS FOR THE MANUFACTURE OR SALE OF ITEMS WITHOUT WRITTEN PERMISSION. COPYRIGHT © 1973, DIGITAL EQUIPMENT CORPORATION.

Y VARIATION CHART

COMPONENTS	M8349 YA	M8349 YC	M8349 YD	M8349
I.C. DEC 1702A	E26,E50	E26,E32,E38 E42,E50,E55	E26,E32,E50	E20,E26,E32, E38,E42,E50, E55
I.C. DEC 5384	E4,E24,E51	E4,E24,E51	E4,E24,E51	E4,E10,E24, E27,E43,E51
JUMPER YA1 SEE NOTE 6	IN	IN	IN	OUT
JUMPER YA2	IN	IN	IN	OUT
I.C. DEC 74151	0	0	0	E16
I.C. DEC 74200	0	0	0	E27,E11,E15, E19,E23,E25,E28, E33,E37,E41,E46

* DIODE & JUMPER SETTINGS FOR ADDRESS DEFINITIONS

MEMORY FIELD SELECT	DIODE					
	D3	D4	D5	D6	D9	D10
0	1	-	1	-	-	1
1	-	1	1	-	-	1
2	1	-	1	-	1	-
3	-	1	1	-	-	-
4	1	-	-	1	-	1
5	-	1	-	1	-	1
6	1	-	-	1	1	-
7	-	1	-	1	1	-

'SW' OR 'BC01' FIELD SELECT	JUMPER BELOW		
	R4	R5	R6
0	1	1	1
1	1	1	1
2	1	-	1
3	1	-	1
4	-	1	1
5	-	1	1
6	-	-	1
7	-	-	-

FIRST MEMORY ADDRESS	D1	D2	D3	D4	D5	D6	D7	D8	D9	D10
0000	1	1	1	1	1	1	1	1	1	1
0400	1	1	1	1	1	1	1	1	1	1
4000	1	1	1	1	1	1	1	1	1	1
6000	1	1	1	1	1	1	1	1	1	1

STARTING MEMORY ADDRESS	JUMPER BELOW	R1	R2	R3
0000	1	1	1	1
0200	1	1	1	1
2000	1	1	1	1
2200	1	1	1	1
4000	1	1	1	1
4200	1	1	1	1
6000	1	1	1	1
6200	1	1	1	1

* 1 = DIODE OR JUMPER IN
- = DIODE OR JUMPER OUT

QTY	QTY	QTY	QTY	REF DESIGNATION	DESCRIPTION	PART NO.	ITEM NO.
12	0	0	0	SEE Y VARIATION CHART	I.C. DEC 74200 (3106)	1910618-2	56
4	0	0	0	E6,E10,E35,E40	I.C. DEC 74157	1910655	57
1	0	0	0	D82	CAP 568PF 100V 5%	1000025	58
1	0	0	0	R40	RES. 10K POT 3/4W 10%	1309143-10	59
1	0	0	0		HEAT SINK: TRANSISTOR	1210001	61
REF	0	0	0		X-Y COORDINATE HOLE LOCATION	K-CO-M8349-0-4	62
REF	0	0	0		ASSY/DRILLING HOLE LAYOUT	D-AH-M8349-0-5	63
REF	0	0	0		ECO MODULE HISTORY	B-MH-M8349-0-6	64
1	0	0	0		ETCH CIRCUIT BOARD	5010-126	65

M8349-YA
M8349-YC
M8349-YD

REVISIONS		
CHK	CHANGE NO	REV

REV. DATE DCS M8349-0-1 F

THIS DRAWING AND SPECIFICATIONS, HEREIN ARE THE PROPERTY OF DIGITAL EQUIPMENT CORPORATION AND SHALL NOT BE REPRODUCED OR COPIED OR USED IN WHOLE OR IN PART AS THE BASIS FOR THE MANUFACTURE OR SALE OF ITEMS WITHOUT WRITTEN PERMISSION. COPYRIGHT © 1973, DIGITAL EQUIPMENT CORPORATION.

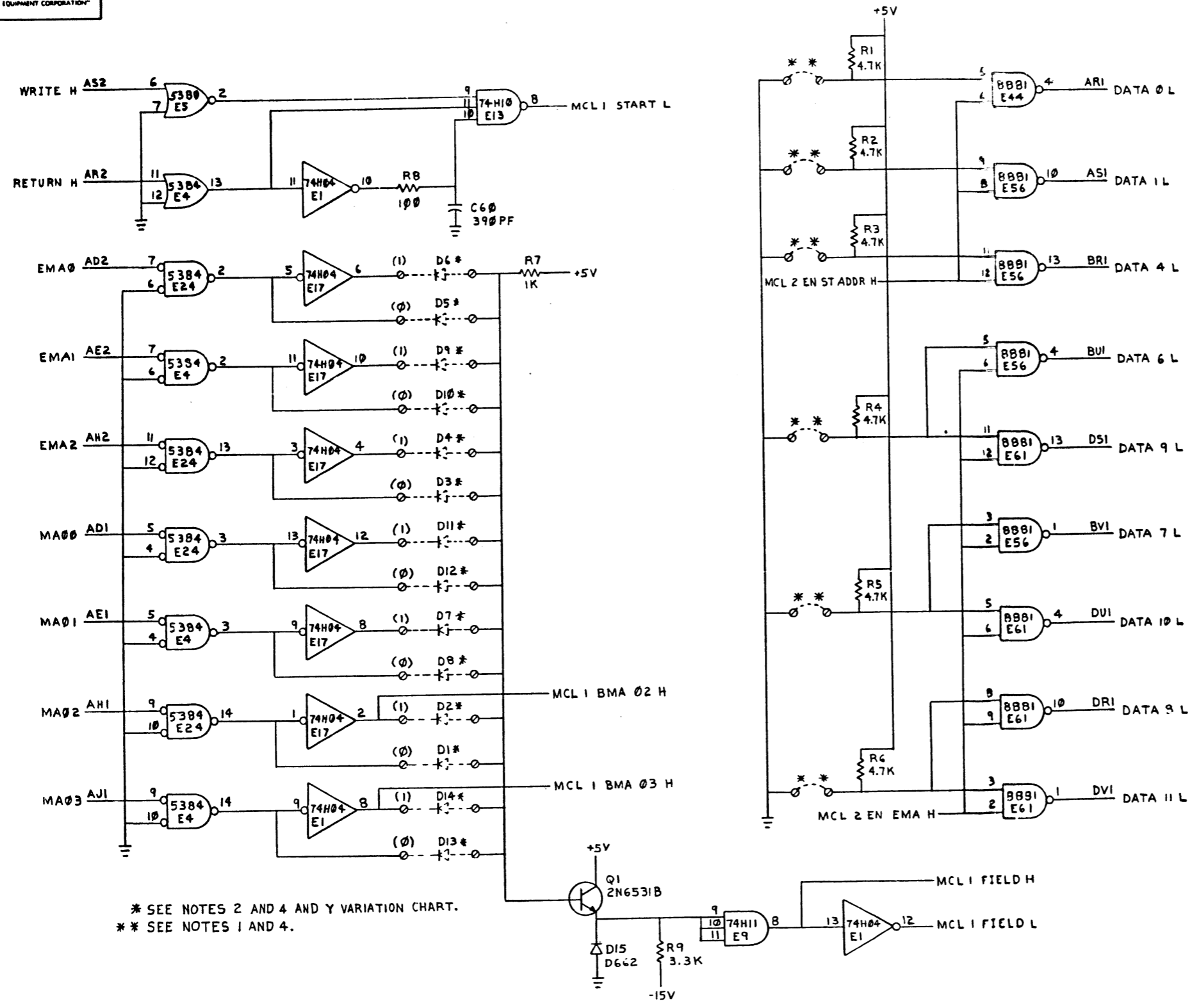

* SEE NOTES 2 AND 4 AND Y VARIATION CHART.
 ** SEE NOTES 1 AND 4.

SW. STARTING ADDRESS

SW. FIELD SELECTION (IF AND DF)

REVISIONS		
CHK	CHANGE NO.	REV.

TITLE	PROM 1K (MCL1)	SIZE/CODE	D CS	NUMBER	M8349-0-1	REV.	F
SCALE		SHEET	3	OF	7	DIST.	

THIS DRAWING AND SPECIFICATIONS HEREIN ARE THE PROPERTY OF DIGITAL EQUIPMENT CORPORATION AND SHALL NOT BE REPRODUCED OR COPIED OR USED IN WHOLE OR IN PART AS THE BASIS FOR THE MANUFACTURE OR SALE OF ITEMS WITHOUT WRITTEN PERMISSION. COPYRIGHT © 1973 DIGITAL EQUIPMENT CORPORATION.

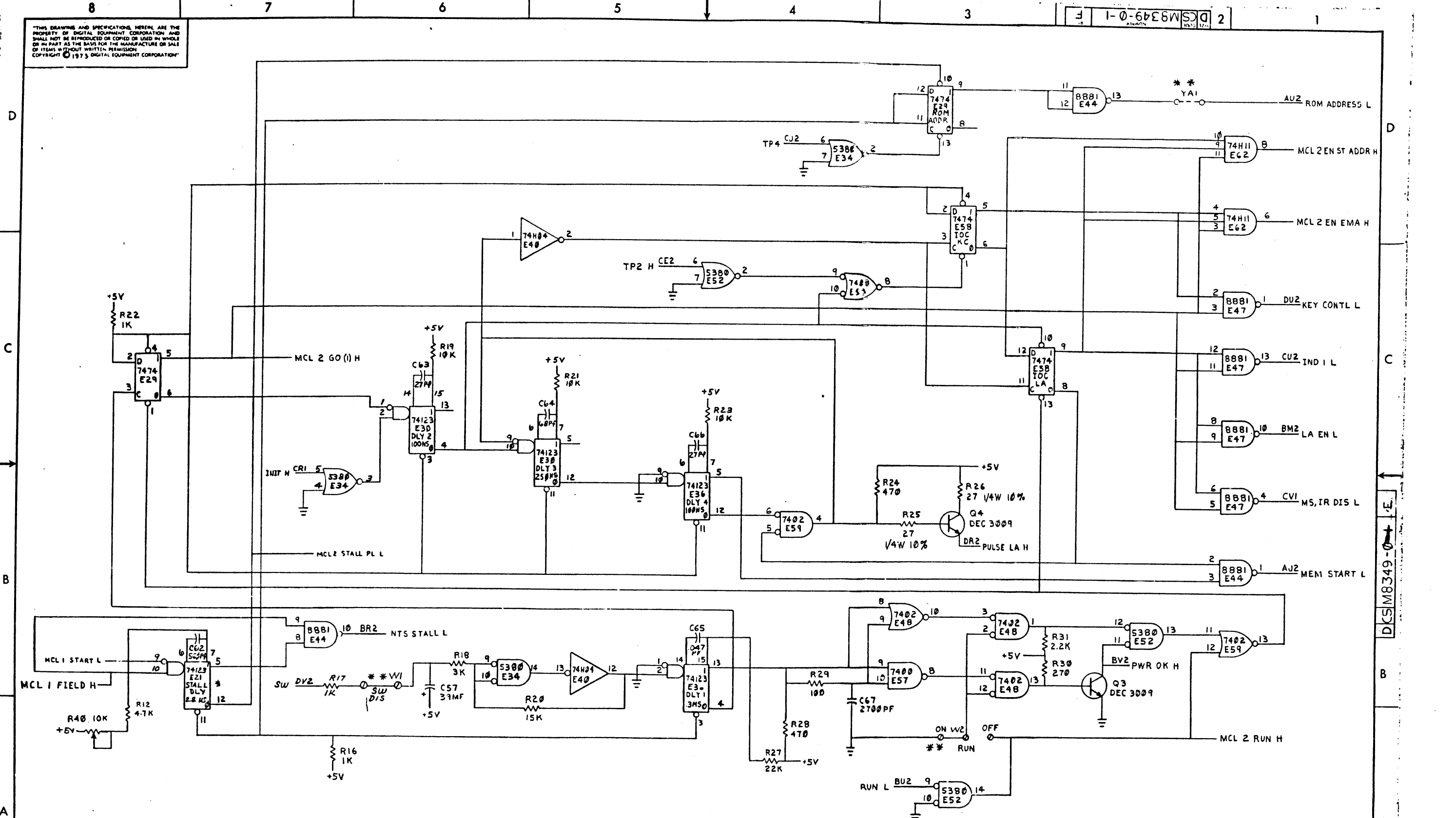

* SEE NOTE 3
 ** SEE NOTE 4

REVISIONS		
CHK	CHANGE NO.	REV.

8	7	6	5	4	3	2	1		
TITLE . PROM 1K (MCL2) DCS M8349-0-1							SIZE CODE	NUMBER	REV.
SCALE							SHEET 4 OF 7	DIST	F

DCS M8349-0-1

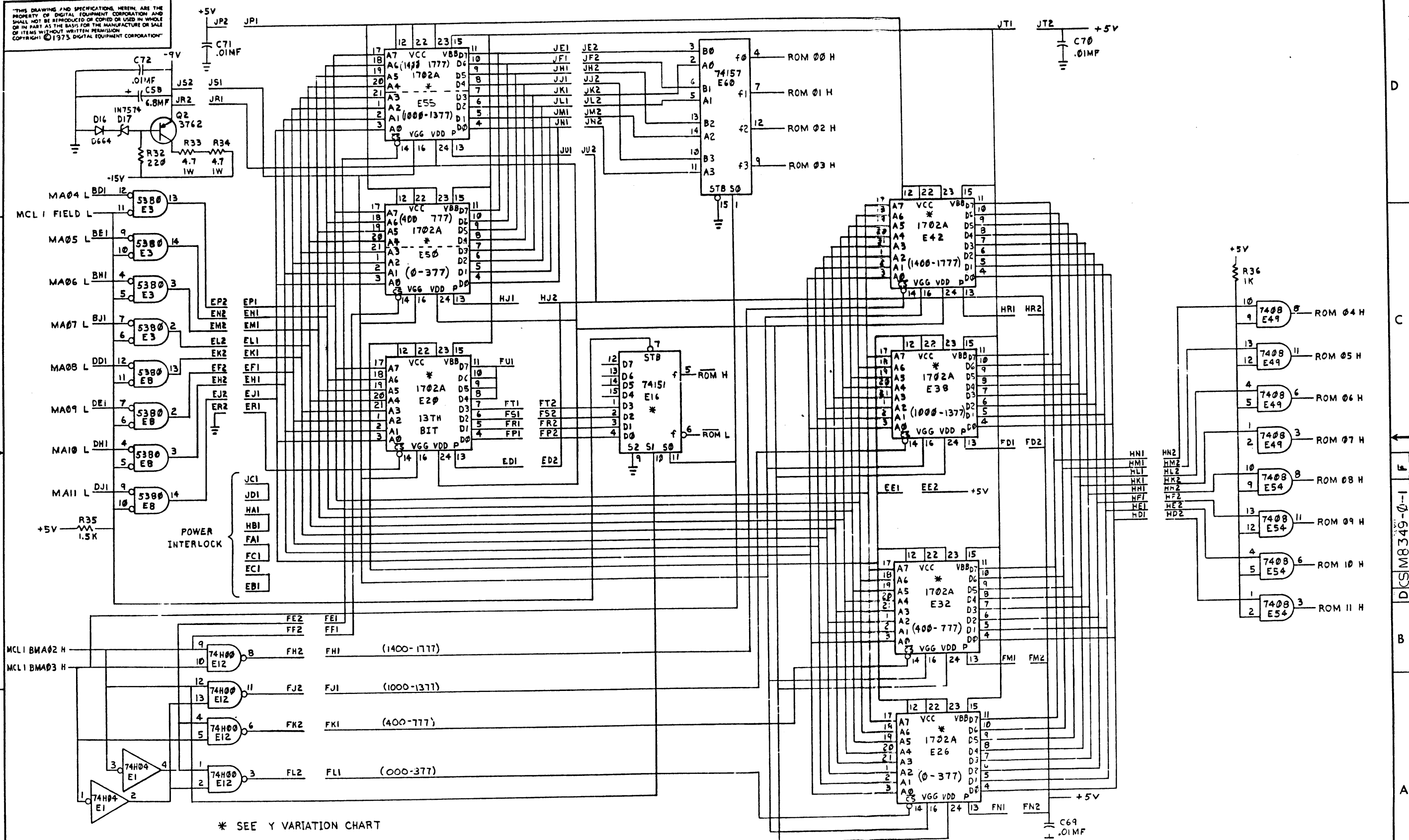

* SEE Y VARIATION CHART

REVISIONS		
CHK	CHANGE NO	REV

TITLE	PROM 1K (ROM)	SIZE CODE	DCS	NUMBER	M8349-0-1	REV.	F
SCALE		SHEET	5	OF	7	DIST.	

THIS DRAWING AND SPECIFICATIONS HEREIN ARE THE PROPERTY OF DIGITAL EQUIPMENT CORPORATION AND SHALL NOT BE REPRODUCED OR COPIED OR USED IN WHOLE OR IN PART AS THE BASIS FOR THE MANUFACTURE OR SALE OF ITEMS WITHOUT WRITTEN PERMISSION. COPYRIGHT © 1973, DIGITAL EQUIPMENT CORPORATION.

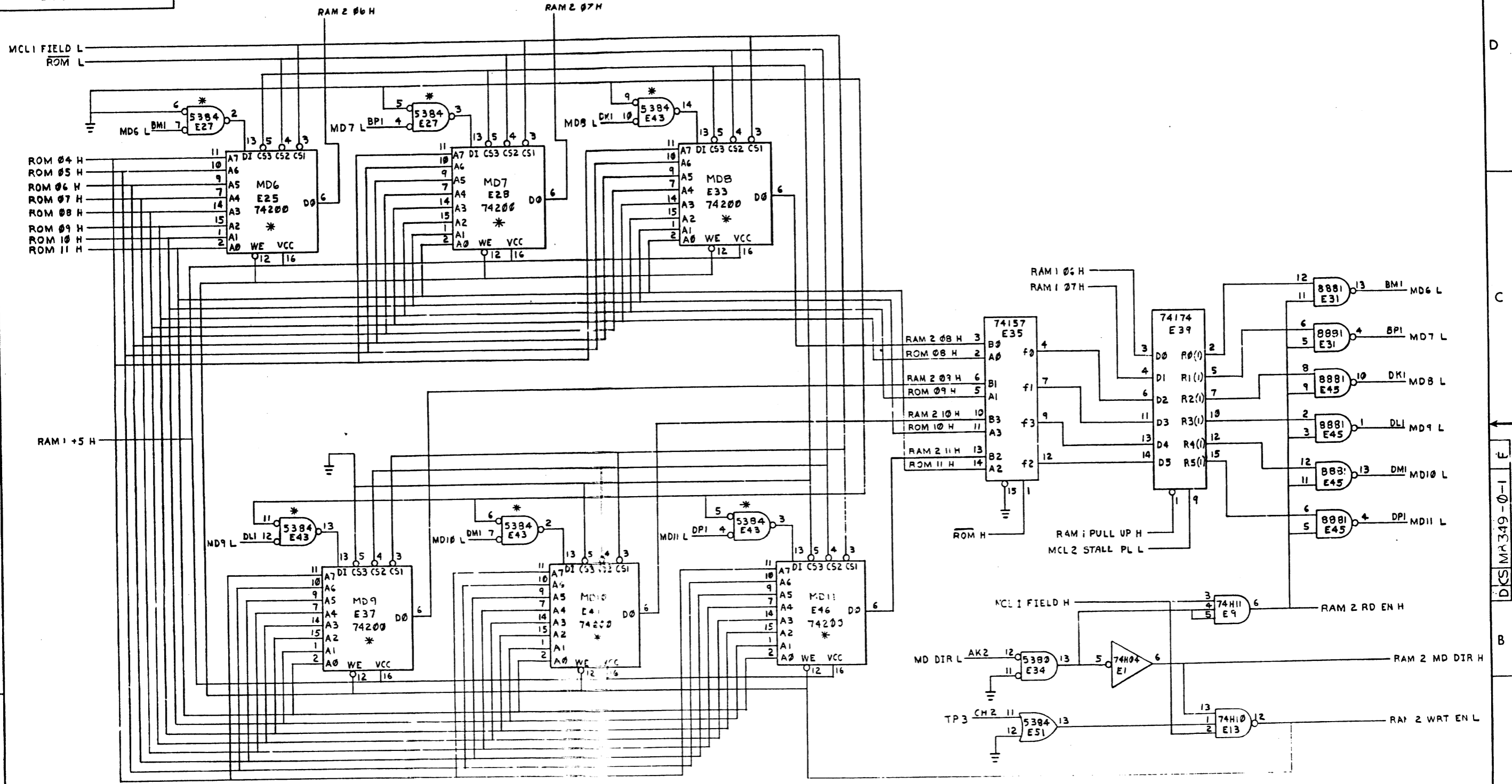

* SEE Y VARIATION CHART

REVISIONS		
CHK	CHANGE NO	REV

TITLE	PROM 1K (RAM 2)	DCS M8349-0-1	NUMBER		REV	F
SCALE		SHEET 7 OF 7	DIST			