

"THIS DRAWING AND SPECIFICATIONS HEREIN ARE THE PROPERTY OF DIGITAL EQUIPMENT CORPORATION AND SHALL NOT BE REPRODUCED OR COPIED OR USED IN WHOLE OR IN PART AS THE BASIS FOR THE MANUFACTURE OR SALE OF ITEMS WITHOUT WRITTEN PERMISSION. COPYRIGHT © 1977 DIGITAL EQUIPMENT CORPORATION"

5 158AZ/159AZ 500 2

BOOTSTRAP/AUTO RESTART FUNCTIONAL SWITCH SETTINGS

DESIRED FUNCTION	ACTIVATING SIGNAL	S1-4	S1-5	S1-6	S1-7	S1-8	S2-1
BOOTSTRAP ENABLED	"BOOT" SW	*	↑	OFF	OFF	ON	N/A
AUTO-RESTART DISABLED	N/A						
BOOTSTRAP ENABLED	"BOOT" SW	*		ON	ON	ON	N/A
AUTO-RESTART ENABLED	"AC LOW"						
BOOTSTRAP DISABLED	N/A	*	SPARE	ON	ON	OFF	N/A
AUTO-RESTART ENABLED	"AC LOW"						
BOOTSTRAP ENABLED	"AC LOW"	*		ON	OFF	OFF	N/A
AUTO-RESTART DISABLED	N/A						
BOOTSTRAP ENABLED	"AC LOW" OR "BOOT" SW	*		ON	OFF	ON	N/A
AUTO-RESTART DISABLED	N/A						
TIME SHARE DISABLED	N/A	N/A	N/A	N/A	N/A	N/A	ON
TIME SHARE ENABLED	N/A	N/A	N/A	N/A	N/A	N/A	OFF

NOTES:

- * S1-4 "OFF" - BOOTSTRAP CAN BE ACTIVATED BY "BOOT" SW EITHER IN THE "RUN" OR "STOPPED" STATE
- S1-4 "ON" - BOOTSTRAP CAN ONLY BE ACTIVATED BY "BOOT" SW IN THE "RUN" STATE
- 1. "AC LOW" WILL CAUSE AUTO-RESTART OR BOOTSTRAP, DEPENDING ON SWITCH SETTINGS, TO OCCUR ONLY IN THE "RUN" OR STOPPED STATE
- S1-6, 7, 8 "OFF" - BOOTSTRAP & AUTO-RESTART DISABLED
- 2. E76 & E81 ARE NOT ON THE VC VARIATION KMB-AD. ALL OTHER PARTS REMAIN THE SAME
- 3. IF AUTO-RESTART IS ENABLED, THE AUTO-START FEATURE OF THE CPU (M8315) MUST BE DISABLED

BOOTSTRAP SELECT SWITCH SETTINGS FOR 158AZ/159AZ ROMS

PROGRAM	S2-5	S2-6	S2-7	S2-8	S1-1	S1-2	S1-3	ROM ST ADD	MEM ADD START
HI-LO PTRDR	ON	ON	ON	OFF	ON	ON	ON	20	7734
RKBE	ON	OFF	ON	OFF	ON	OFF	ON	124	24
RXBE	ON	OFF	OFF	ON	OFF	ON	ON	150	33
RFDB/DFB2P	OFF	ON	OFF	ON	OFF	ON	OFF	252	7750
TABE	OFF	ON	OFF	OFF	OFF	ON	OFF	272	4000

- 3. BOOTSTRAP SELECT SWITCHES ARE DEFINED AS FOLLOWS:
- (a) ROM ADDRESS RANGE: 0-377
- (b) ON = LOGIC 0 OR LOW; OFF = LOGIC 1 OR HIGH
- (c) ORDER OF SIGNIFICANCE
- $S_2 5 = 2^7 = 200$ (MSB)
- $S_2 6 = 2^6 = 100$
- $S_2 7 = 2^5 = 40$
- $S_2 8 = 2^4 = 20$
- $S_1 1 = 2^3 = 10$
- $S_1 2 = 2^2 = 4$
- $S_1 3 = 2^1 = 2$

THE LSB OF ADDRESS IS CONTROLLED BY THE BOOTSTRAP/AUTO-RESTART LOGIC

BOOTSTRAP SELECT SWITCH SETTINGS FOR 465AZ/469AZ ROMS

PROGRAM	S2-5	S2-6	S2-7	S2-8	S1-1	S1-2	S1-3	ROM ST ADD	MEM ST ADD
HI-LO PTR	ON	ON	ON	OFF	ON	ON	ON	20	7734
RKBE	ON	OFF	ON	OFF	ON	OFF	ON	124	24
* RXBE	ON	OFF	OFF	ON	OFF	ON	ON	150	33
RLA	OFF	ON	OFF	OFF	OFF	ON	OFF	272	1

* RXBE BOOT FOR BOTH RX01 AND RX02

FOR BOTH 158AZ/159AZ & 465AZ/469AZ ROMS

AUTO-RESTART SELECT SWITCH SETTINGS

RESTART ADDRESS	S2-2	S2-3	S2-4
0	OFF	OFF	OFF
2000	OFF	ON	OFF
2000	ON	OFF	OFF
4200	ON	ON	OFF

- 4. AUTO-RESTART SELECT SWITCHES ARE DEFINED AS FOLLOWS:
- (a) ROM ADDRESS RANGE: 0-16
- (b) ON = LOGIC 1 OR LOW; OFF = LOGIC 0 OR HIGH
- (c) ORDER OF SIGNIFICANCE
- $S_2 2 = 2^3 = 10$
- $S_2 3 = 2^2 = 4$
- $S_2 4 = 2^1 = 2$

5. TO CONFIGURE MODULE FOR USE WITH KT8-A OPTION, INSTALL JUMPERS AS SHOWN BELOW

	W1	W2	W3	W4
NORMAL	IN	OUT	OUT	OUT
WITH KT8A	OUT	IN	IN	IN

COMPONENT SUBSTITUTION CHART

PART CALLED FOR		SUBSTITUTE PART			
QTY	PART NO.	DESCRIPTION	QTY	PART NO.	DESCRIPTION
96	1001610-01	0147FD DISC	96	1001610-00	0147FD GLASS
3	15C3100	DEC 3000B	3	1509338	DEC 6531
6	1911330	74173	6	1911711	8T10
1	1909704	314	1	1910391	5314
			1	1909972	6314
			1	1910389	7314
6	1909705	8881	6	1909973	97401
1	23158AZ	ROM 1 (E76)	1	23465AZ	ROM 1 (E76)
1	23159AZ	ROM 2 (E81)	1	23469AZ	ROM 2 (E81)

QTY	REF. DESIGNATION	DESCRIPTION	PART NO.	ITEM NO.
12	12	INSULATED, JUMPER WIRE	9009185	52
1	1	EYELET, HANDLE	9800024-01	53
1	1	HANDLE ASSY	1210711-02	54
1	1	RES. 470Ω 1/4W 5%	1300316	55
1	1	CAP. 0.022MF 50V 10%	1011683	56
1/2	1/2	THIN WALL TUBING	9107256-11	57

PARTS LIST

QTY	QTY	REF. DESIGNATION	DESCRIPTION	PART NO.	ITEM NO.
			TITLE	SIZE CODE	NUMBER
			OPTION BOARD #2	D CS	M8317-YB-1
			SCALE NONE	SHEET 2 OF 7	DIST.

REVISIONS		
CHK	CHANGE NO.	REV.

M8317-YB-1 3

B

A

THIS DRAWING AND SPECIFICATIONS HEREIN ARE THE PROPERTY OF DIGITAL EQUIPMENT CORPORATION AND SHALL NOT BE REPRODUCED OR COPIED OR USED IN WHOLE OR IN PART AS THE BASIS FOR THE MANUFACTURE OR SALE OF ITEMS WITHOUT WRITTEN PERMISSION. COPYRIGHT © 1977 DIGITAL EQUIPMENT CORPORATION

S 1-BX-2119N 10021375 2

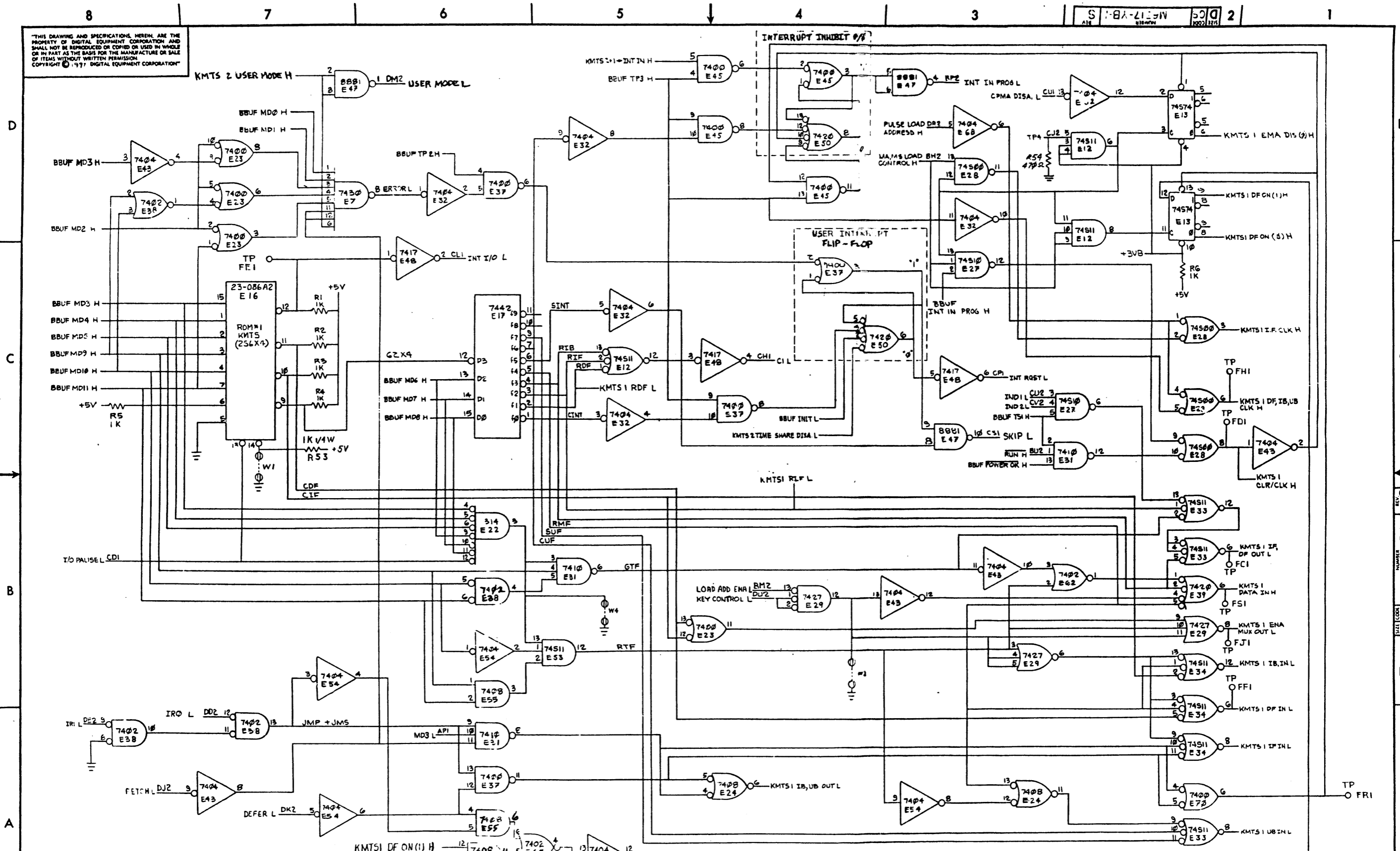

REVISIONS		
CHK	CHANGE NO.	REV.

MEMORY EXT/TIME SHARE REGISTER CONTROL

TITLE	OPTION BOARD #2 (KMTS 1)	SIZE/CODE	D 05	NUMBER	MB317-Y9-1	REV.	S
SCALE	NONE	SHEET	3	OF	7	DIST.	

THIS DRAWING AND SPECIFICATIONS HEREIN ARE THE PROPERTY OF DIGITAL EQUIPMENT CORPORATION AND SHALL NOT BE REPRODUCED OR COPIED OR USED IN WHOLE OR IN PART AS THE BASIS FOR THE MANUFACTURE OR SALE OF ITEMS WITHOUT WRITTEN PERMISSION. COPYRIGHT © 1977 DIGITAL EQUIPMENT CORPORATION

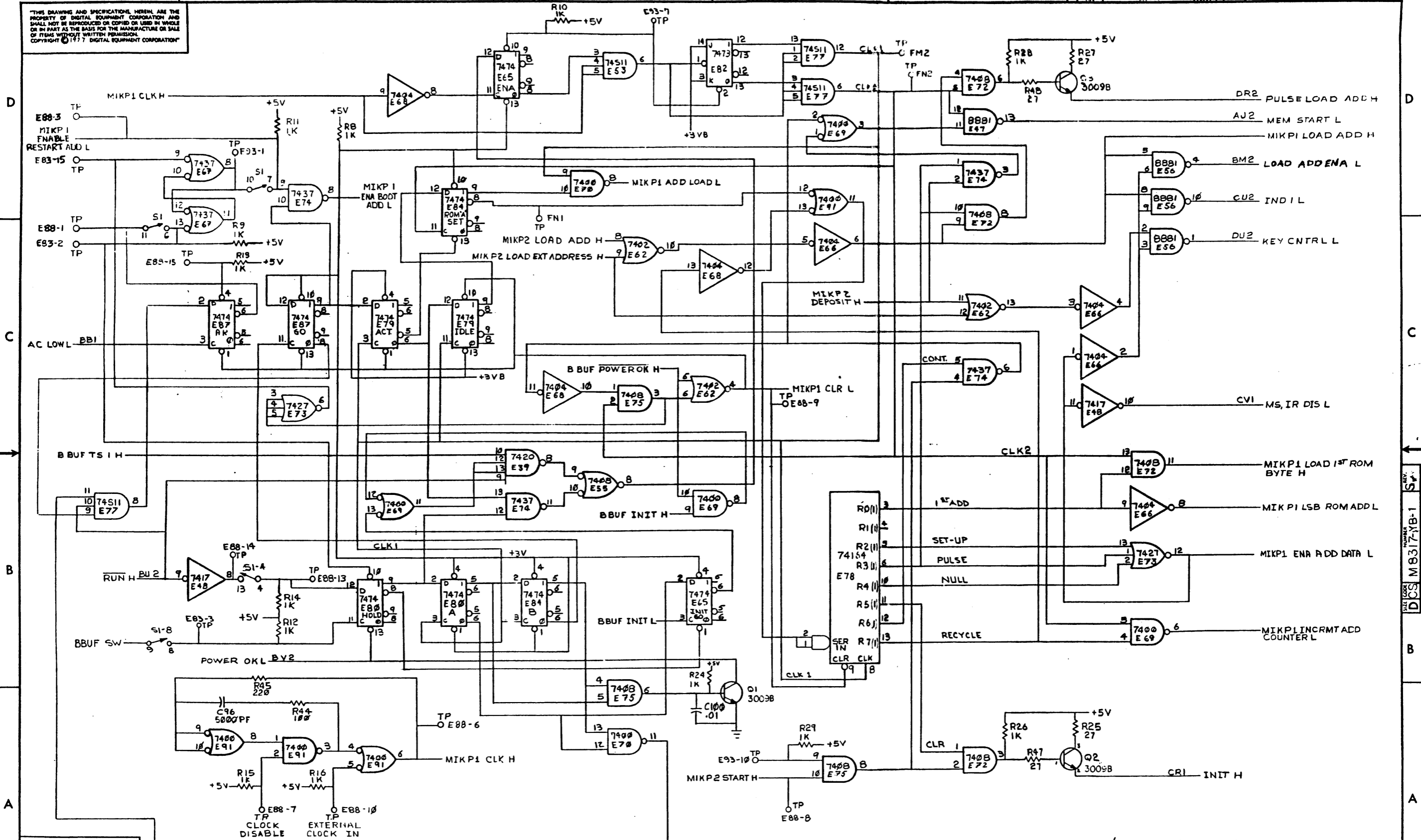

BOOTSTRAP/AUTORESTART CONTROL

REVISIONS		
CHK	CHANGE NO.	REV.

TITLE	OPTION BOARD # 2 (MIKP1)	SIZE CODE	D CS	NUMBER	M8317-YB-1	REV.	S
SCALE	+	SHEET	5	OF	7	DIST.	

"THIS DRAWING AND SPECIFICATIONS, HEREIN, ARE THE PROPERTY OF DIGITAL EQUIPMENT CORPORATION AND SHALL NOT BE REPRODUCED OR COPIED OR USED IN WHOLE OR IN PART AS THE BASIS FOR THE MANUFACTURE OR SALE OF ITEMS WITHOUT WRITTEN PERMISSION. COPYRIGHT © 1977 DIGITAL EQUIPMENT CORPORATION"

D
C
B
A

D
C
B
A

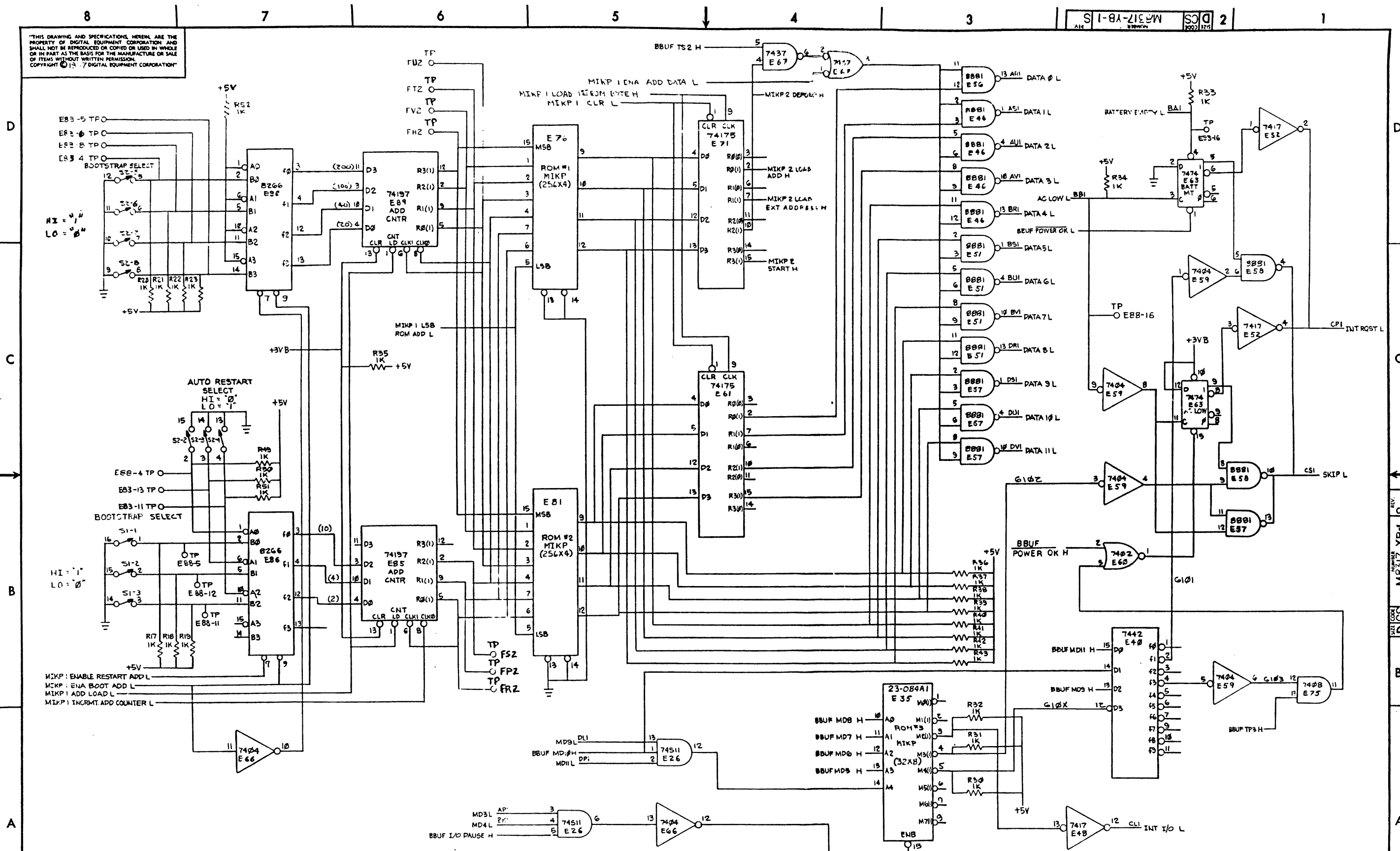

REVISIONS		
CHK	CHANGE NO.	REV.

TITLE		OPTION BOARD #2 (MKP 2)		SIZE CODE	D CS	NUMBER	M8317-YB-1	REV.	S ₂
SCALE	NONE	SHEET	6 OF 7	DIST.					

THIS DRAWING AND SPECIFICATIONS HEREIN ARE THE PROPERTY OF DIGITAL EQUIPMENT CORPORATION AND SHALL NOT BE REPRODUCED OR COPIED OR USED IN WHOLE OR IN PART AS THE BASIS FOR THE MANUFACTURE OR SALE OF ITEMS WITHOUT WRITTEN PERMISSION. COPYRIGHT © 1977 DIGITAL EQUIPMENT CORPORATION

NOTE: SIGNALS WITH N/C HAVE NO CONNECTION

REV. 2
D CS M8317-YB-1

D
C
B
A

D
C
B
A

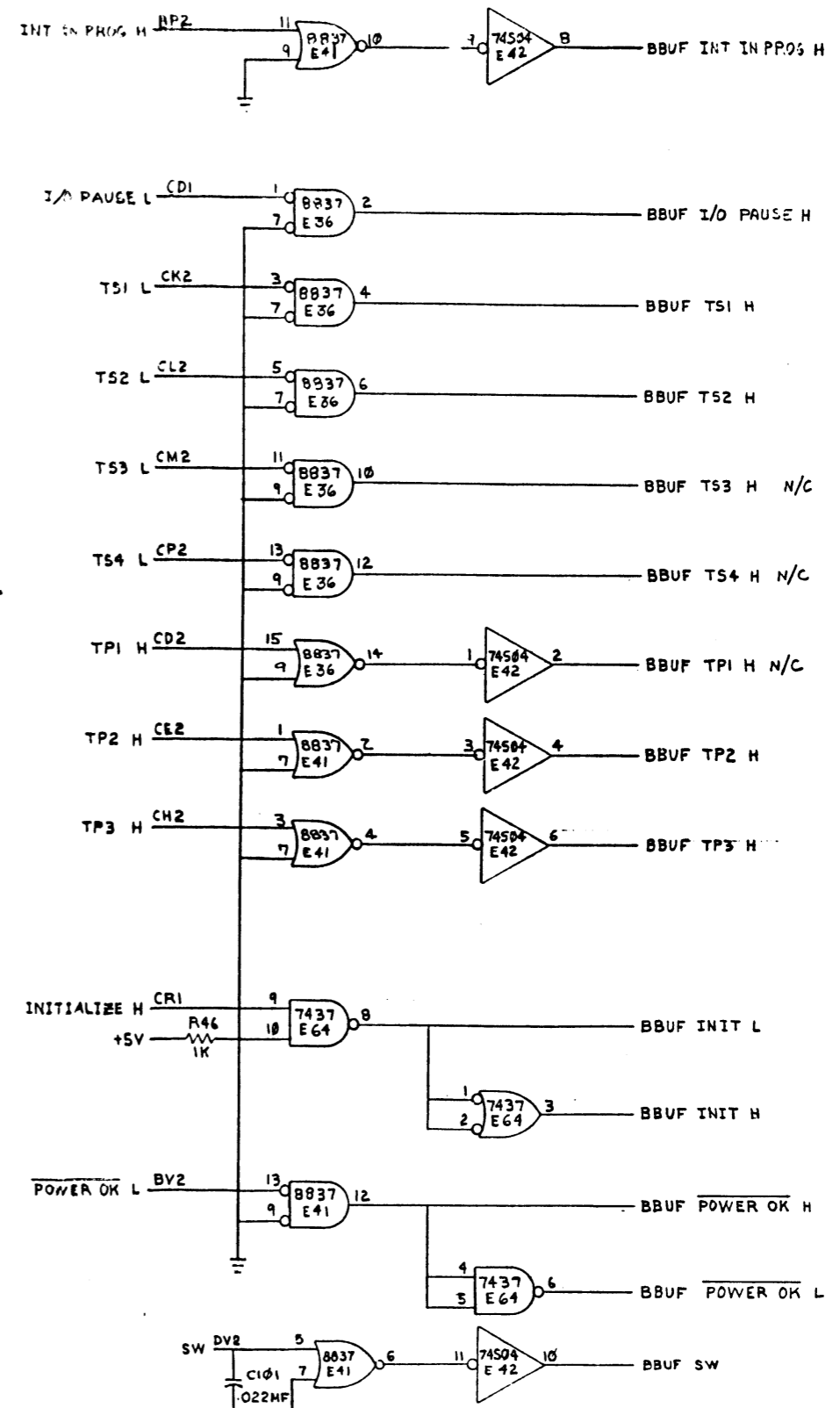
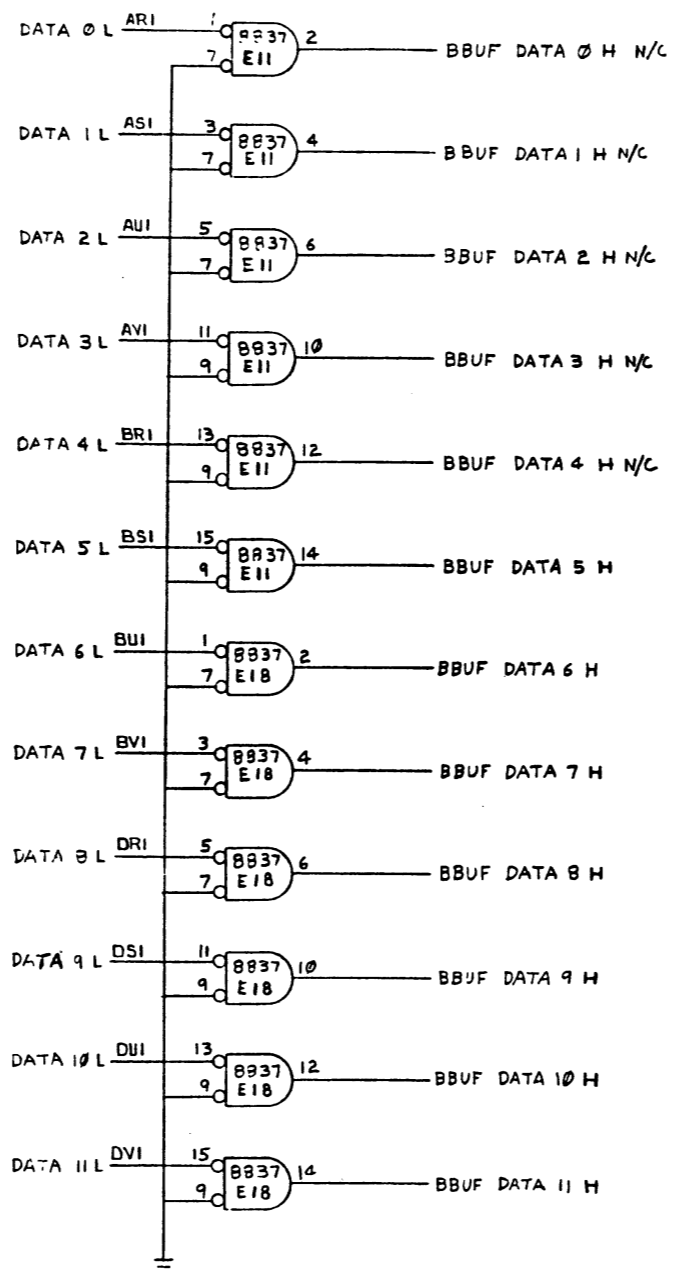
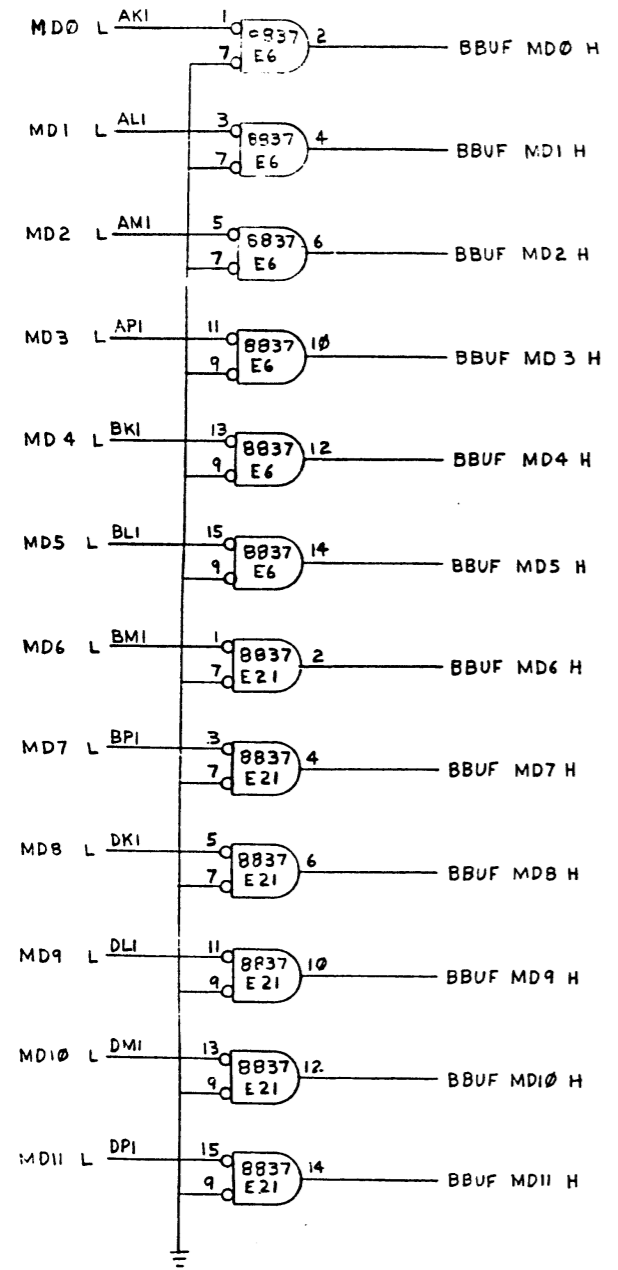

BUS BUFFERS

REVISIONS		
CHK	CHANGE NO.	REV.

TITLE	8/A INTERNAL OPTION #2 (BBUF)	SIZE/ CODE	D CS	NUMBER	M8317-YB-1	REV.	S
SCALE	NONE	SHEET	7	OF	7	DIST.	

THIS DRAWING AND SPECIFICATIONS HEREIN ARE THE PROPERTY OF DIGITAL EQUIPMENT CORPORATION AND SHALL NOT BE REPRODUCED OR COPIED OR USED IN WHOLE OR IN PART AS THE BASIS FOR THE MANUFACTURE OR SALE OF ITEMS WITHOUT WRITTEN PERMISSION. DIGITAL EQUIPMENT CORPORATION. COPYRIGHT © 1974

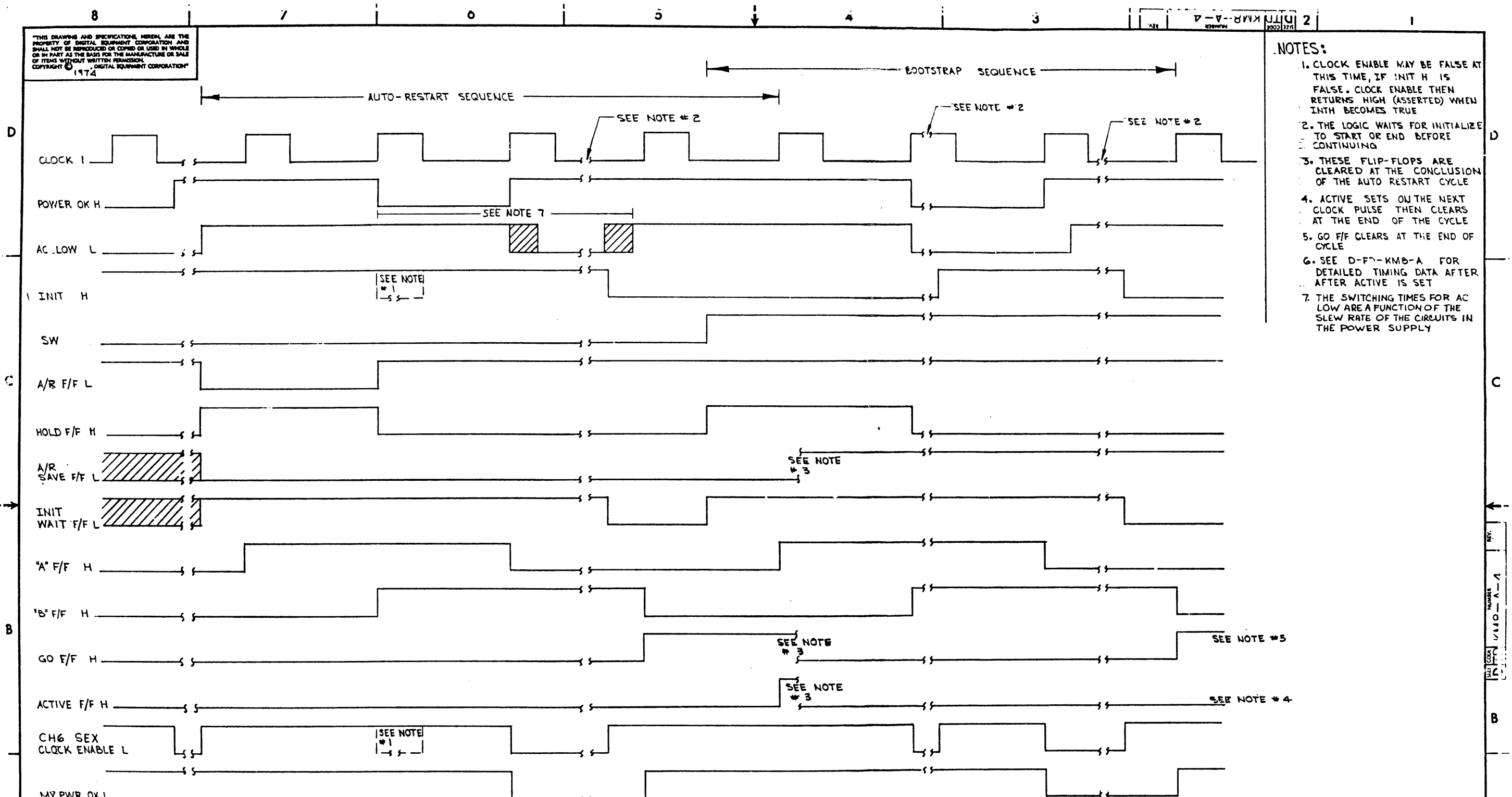

- NOTES:**
1. CLOCK ENABLE MAY BE FALSE AT THIS TIME, IF INIT H IS FALSE. CLOCK ENABLE THEN RETURNS HIGH (ASSERTED) WHEN INTH BECOMES TRUE
 2. THE LOGIC WAITS FOR INITIALIZATION TO START OR END BEFORE CONTINUING
 3. THESE FLIP-FLOPS ARE CLEARED AT THE CONCLUSION OF THE AUTO RESTART CYCLE
 4. ACTIVE SETS ON THE NEXT CLOCK PULSE THEN CLEARS AT THE END OF THE CYCLE
 5. GO F/F CLEARS AT THE END OF CYCLE
 6. SEE D-FD-KMB-A FOR DETAILED TIMING DATA AFTER ACTIVE IS SET
 7. THE SWITCHING TIMES FOR AC LOW ARE A FUNCTION OF THE SLEW RATE OF THE CIRCUITS IN THE POWER SUPPLY

REV.	CHANGE NO.

FIRST USED ON OPTION/MODEL PDP8-A		QTY.	DESCRIPTION	PART NO.	ITEM NO.
PARTS LIST					
DIMENSIONAL TOLERANCE		DRND	DATE		
DIMENSIONS ARE UNLESS OTHERWISE SPECIFIED		DATE	DATE		
THIRD ANGLE PROJECTION		DATE		TITLE	
MATERIAL		DATE		AUTO RESTART/ BOOTSTRAP START-UP SEQUENCE	
FINISH		DATE		NUMBER	
SCALE		DATE		D T D KMB - A - 4	
SHEET 1 OF 1		DIST.		REV.	

REV. 4-A-KMB-1111 2

"THE DRAWING AND SPECIFICATIONS HEREIN ARE THE PROPERTY OF DIGITAL EQUIPMENT CORPORATION AND SHALL NOT BE REPRODUCED OR COPIED OR USED IN WHOLE OR IN PART AS THE BASIS FOR THE MANUFACTURE OR SALE OF ITEMS WITHOUT WRITTEN PERMISSION. COPYRIGHT © 1974, DIGITAL EQUIPMENT CORPORATION"

- NOTES:**
1. ONE "DEPOSIT" CYCLE IS SHOWN IN : DIAGRAM.
 2. WHEN "RUN" IS TRUE (LOW) ALL TIMING IS HELD OFF UNTIL THE NEXT CLOCK PULSE AFTER "RUN" GOES FALSE (HIGH).
 3. FOR THE "LOAD ADD" CYCLE SIGNALS REMAIN THE SAME AS SHOWN EXCEPT THAT "PULSE LOAD ADD" REPLACES "MEM START" AND "KEY CONTROL" IS NEGATED. FOR "EXT. LOAD ADD" KEY CONTROL IS TRUE.
 4. MEM START APPEARS HERE ONLY FOR THE "START" FUNCTION. THE EARLIER MEM START IS FOR "DEPOSITS" ONLY.

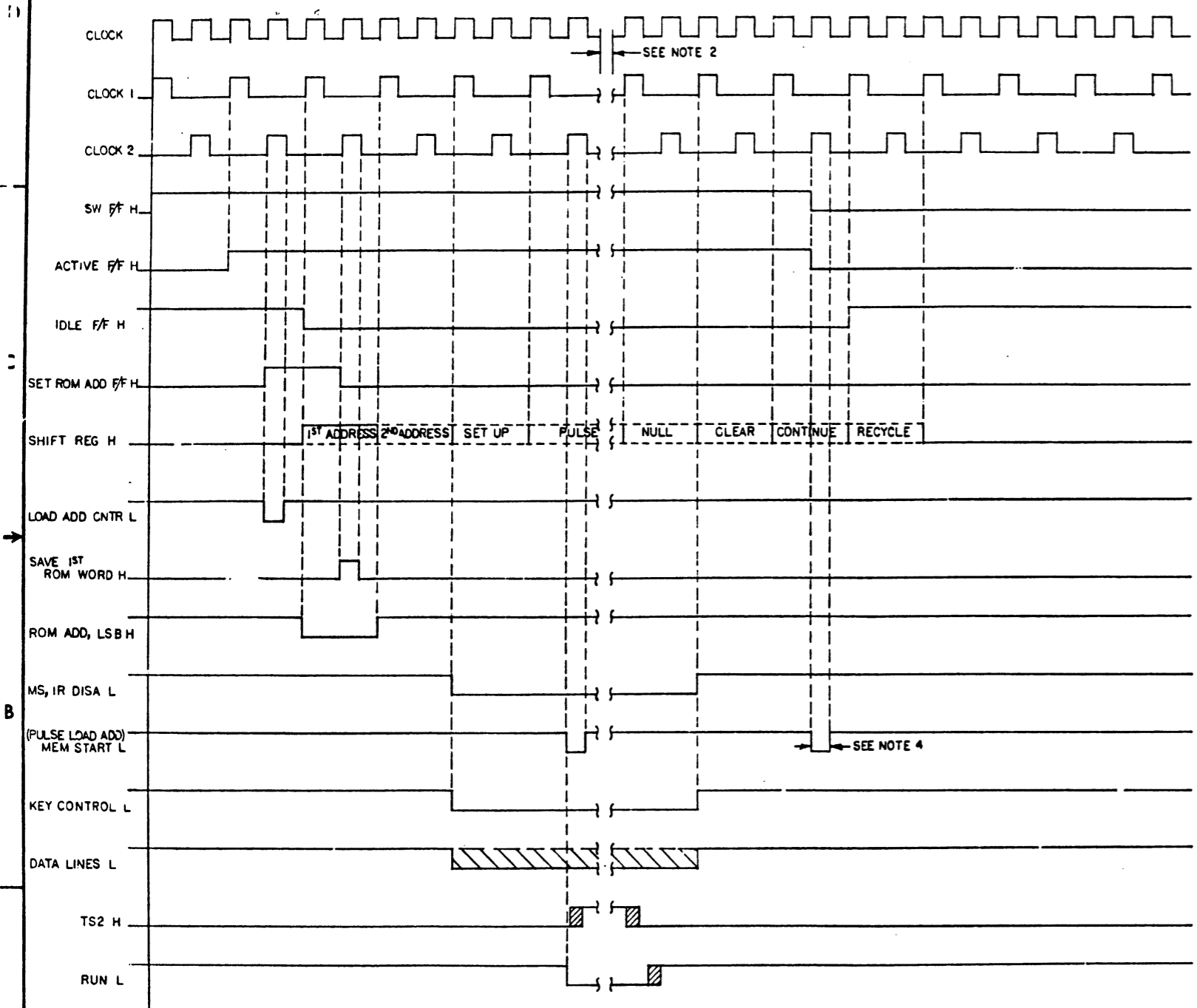

REV.	
CHANGE NO.	
CHK	
REVISIONS	

FIRST USED ON OPTION/MODEL		QTY.	DESCRIPTION	PART NO.	ITEM NO.
PDP8-A					
PARTS LIST					
DIMENSIONAL TOLERANCE		DRW. <i>m white</i>	DATE 7-31-74		
DIMENSIONS ARE MILLIMETERS UNLESS OTHERWISE SPECIFIED		DATE 7/29/74	DATE 7/29/74		
MILLIMETERS INCHES ANGLES		DATE 1-8-75	DATE 8-75		
X.XX ±0.10	JXX ±0.025	90° 30'	DATE 1-8-75	TITLE	
X.X ±0.5	JX ±0.02		DATE 1-8-75	BOOTSTRAP	
X ±0.2	J ±0.1		DATE 1-8-75	TIMING DIAGRAM	
THIRD ANGLE PROJECTION		NEXT HIGHER ASSY.		REV.	
MATERIAL		B-DD-KMB-A		D TD KMB-A-5	
FINISH		SCALE NONE		SHEET OF 1	

This drawing and specifications, herein, are the property of Digital Equipment Corporation and shall not be reproduced or copied or used in whole or in part as the basis for the manufacture or sale of items without written permission (COPYRIGHT © 1974 DIGITAL EQUIPMENT CORPORATION)

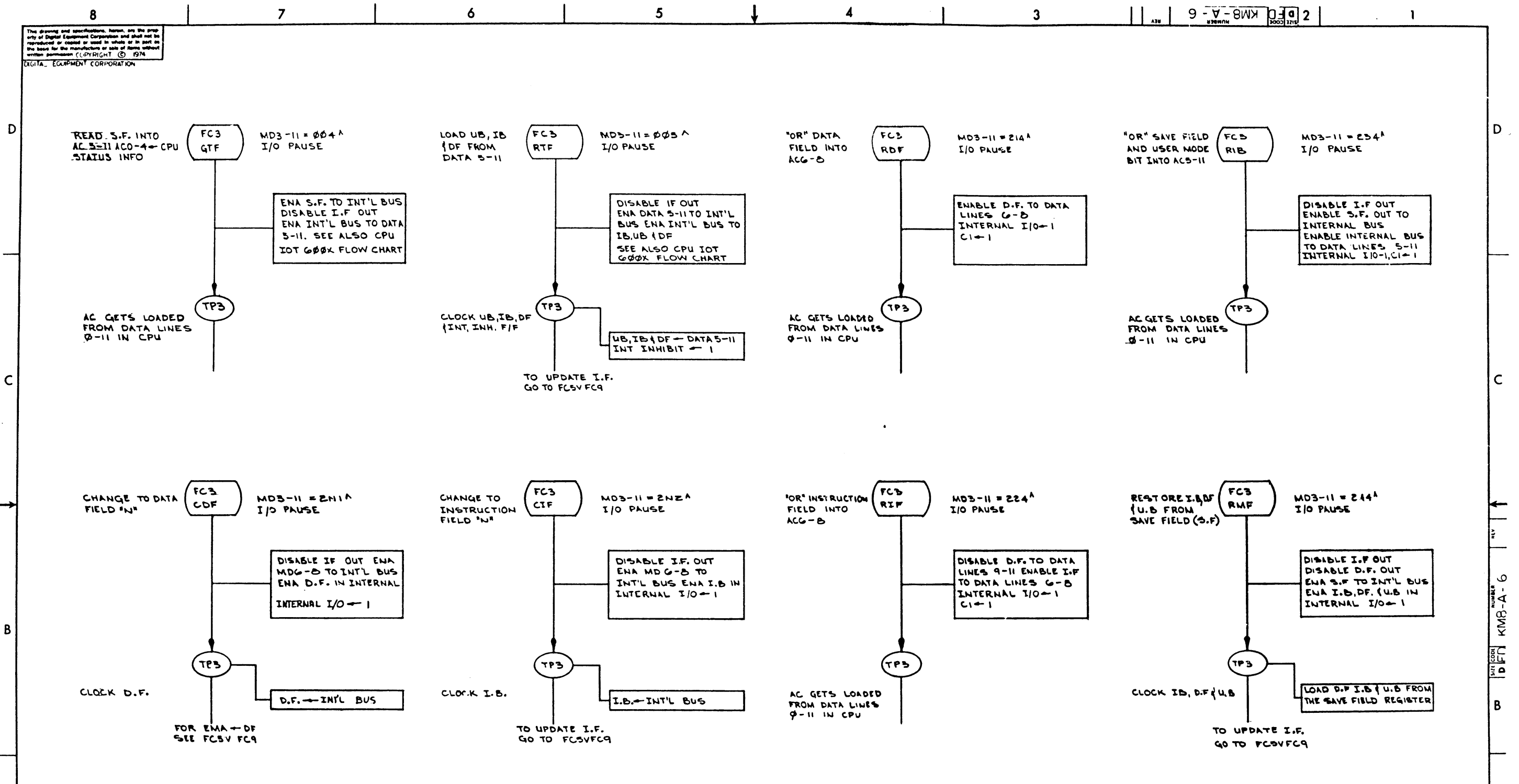

REV.	NO.
CHK.	

FIRST USED ON OPTION MODEL PDP8A	QTY.	DESCRIPTION	PART NO.	ITEM NO.
PARTS LIST				
UNLESS OTHERWISE SPECIFIED DIMENSION IN INCHES TOLERANCES DECIMALS FRACTIONS ANGLES ± .008 ± 1/64 ± 0°30' FINAL SURFACE QUALITY REMOVE BURRS AND BREAK SHARP CORNERS	DATE 12/23/74	DATE 12/23/74	EQUIPMENT CORPORATION MAYNARD, MASSACHUSETTS	
MATERIAL 11	DATE 12/23/74	DATE 12/23/74	TITLE FLOW CHART FOR OPTION BOARD #2 M8317	
FINISH 11	DATE 12/23/74	DATE 12/23/74	SCALE B-DD-KMB-A	NUMBER DFO KMB-A-6
DEC FORM NO DRD 102A	SHEET 1	OF 2	DIGT.	REV.

THIS DRAWING AND SPECIFICATIONS HEREIN ARE THE PROPERTY OF DIGITAL EQUIPMENT CORPORATION AND SHALL NOT BE REPRODUCED OR COPIED OR USED IN WHOLE OR IN PART AS THE BASIS FOR THE MANUFACTURE OR SALE OF ITEMS WITHOUT WRITTEN PERMISSION. © DIGITAL EQUIPMENT CORPORATION 1974

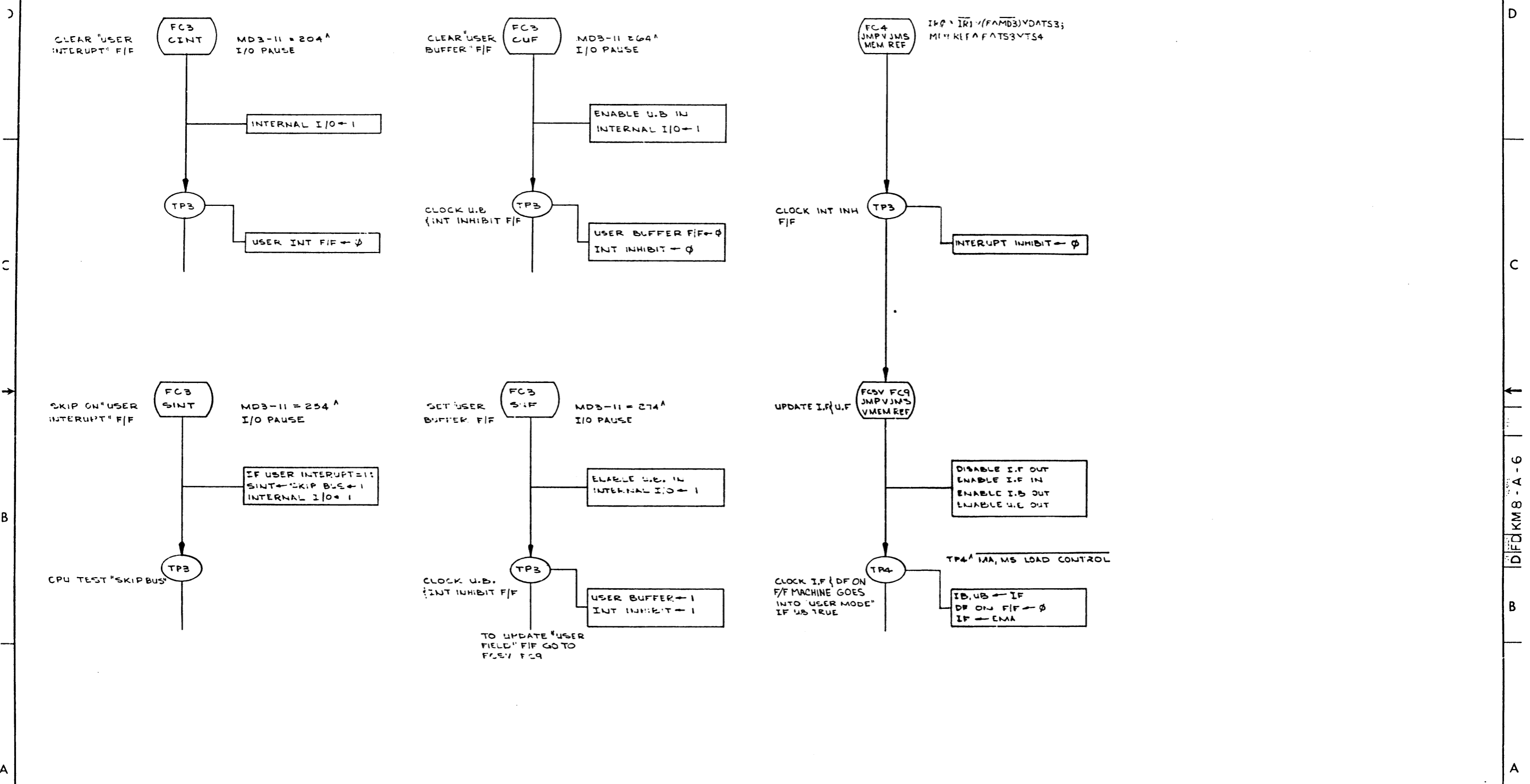

REVISIONS		
CHK	CHANGE NO	REV

DIGITAL EQUIPMENT CORPORATION MAYNARD, MASSACHUSETTS		DATE 5/8/74	
ENGINEERING SPECIFICATION			
TITLE ROM PROGRAMMING DIRECTIONS FOR 8A OPTION BOARD #2 KMB-AD (M8317-YC)			
REVISIONS			
REV	DESCRIPTION	CHG NO	DATE
A	E.C.O. CHANGE	00001	14 MAY 76
B	E.C.O. CHANGE	00002	12-14-77
			5-14-80
APPD	LARRY NATHI	SIZE	A
NUMBER	KMB-A-7	CODE	SP
REV	B	SIZE	A
DEC FORM NO	108	SP	SP
DRA	108	NUMBER	KMB-A-7
		REV	B

This drawing and specifications, herein, are the property of Digital Equipment Corporation and shall not be reproduced or used in whole or in part as the basis for the manufacture or sale of items without written permission.

ENGINEERING SPECIFICATION		CONTINUATION SHEET	
TITLE ROM PROGRAMMING DIRECTIONS FOR 8A OPTION BOARD #2 KMB-AD (M8317-YC)			
1.	Introduction		
	This document describes the organization of the two 256 x 4 ROMs, hereafter called ROM #1 and ROM #2, that control and supply data for the Auto-Restart and Bootstrap portions of Option Board #2.		
	This information is made available to help users program their own ROMs for their specific Auto-Restart and/or Bootstrap program(s).		
2.	Organization		
	The two ROMs are connected as follows: the address lines are connected in parallel; i.e., two corresponding address lines of each ROM are connected together, the outputs are arranged in serial fashion forming an 8 bit word, 4 outputs from each ROM. Because 12 bits are required for data/address information, two sequential addresses must be accessed from the ROMs to form a 16 bit word. Where the first 8 bits are temporarily stored in a register, then the next 8 bits are accessed from the ROMs. At this point the control then decides what to do with 12 of the 16 bits. There are four possible actions that can take place at this time:		
	a) Load Address b) Load Extended Address, IF AND DF c) Deposit d) Start		
	The remaining 4 bits of the 16 actually tell the control which of the four actions are to take place. So the 16 bit word would look like the word in Figure 1.		
		SIZE	A
		CODE	SP
		NUMBER	KMB-A-7
		REV	B
		DEC FORM NO	108
		DRA	108
		SHEET	2 OF 6

ENGINEERING SPECIFICATION		CONTINUATION SHEET	
TITLE ROM PROGRAMMING DIRECTIONS FOR 8A OPTION BOARD #2 KMB-AD (M8317-YC)			
3.	Auto-Restart/Bootstrap Sequence		
	The following events should take place when an auto-restart is initiated:		
	a) Load a 12 bit address b) LOAD THE IF AND DF AND START.		
	The following events should take place when the Bootstrap is initiated:		
	a) Load a 12 bit initial address. b) Load the IF AND DF c) Deposit 12 bit data words repeating as required by length of program to be deposited. d) Load a 12 bit starting address and start.		
		SIZE	A
		CODE	SP
		NUMBER	KMB-A-7
		REV	B
		DEC FORM NO	108
		DRA	108
		SHEET	3 OF 6

Figure 1

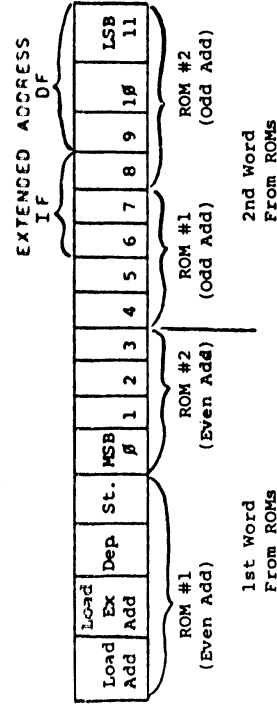

The use of ROMs that have 256 addressable locations allows up to 128 words of ROM storage. These 128 locations may be used for Bootstrap and/or Auto-restart programs. Any Auto-restart or Bootstrap program may be located anywhere in the ROMs so long as the program starts in an even address in the ROM. If it is required that both Bootstrap and Auto-restart programs be accessible at the same time, activated by different signals; of course the Auto-restart program(s) must be located in addresses β through 15 in the ROMs. This is due to the addressing limits of the Auto-restart select switches.

3. Auto-Restart/Bootstrap Sequence

The following events should take place when an auto-restart is initiated:

- a) Load a 12 bit address
- b) LOAD THE IF AND DF AND START.

The following events should take place when the Bootstrap is initiated:

- a) Load a 12 bit initial address.
- b) Load the IF AND DF
- c) Deposit 12 bit data words repeating as required by length of program to be deposited.
- d) Load a 12 bit starting address and start.

ENGINEERING SPECIFICATION		CONTINUATION SHEET	
TITLE ROM PROGRAMMING DIRECTIONS FOR 8A OPTION BOARD #2 KMB-AD (M8317-YC)			
	The decision to do a Bootstrap or an auto-restart is directed by a set of switches on the module. The Bootstrap may be actuated by the transition of the signal AC Low from a logic low to a logic high or by a similar transition of the SW line on the OMNIBUS.		
	AN AUTO-RESTART MAY ONLY BE INITIATED BY THE AC LOW SIGNAL. IT SHOULD BE OBVIOUS THAT BOTH THE BOOTSTRAP OR AUTO-RESTART SHOULD NOT BE ACTIVATED BY THE SAME INITIALIZING SIGNAL.		
4.	ROM Programming Examples		
	Auto-restart example:		
	a) Load address $\beta\beta\beta$ b) Load field β , start		
	Starting at ROM address $\beta\beta\beta$		
	Bootstrap example:		
	a) Load address $\beta\beta\beta$ b) Load field 7 (BOTH IF AND DF) c) Deposit $2\beta\beta\beta$ d) Deposit 6745 e) Deposit $\beta\beta\beta$ f) Deposit 765 β g) Deposit 5 β 24 h) Deposit 5733 i) Deposit 5 β 31 j) Load address $\beta\beta\beta$ and start		
	Starting at ROM address 124.		
		SIZE	A
		CODE	SP
		NUMBER	KMB-A-7
		REV	B
		DEC FORM NO	108
		DRA	108
		SHEET	4 OF 6

TITLE ROM PROGRAMMING DIRECTIONS FOR 8A OPTION BOARD #2 KM8-AD (M8317-YC)

Auto-Restart example:

Bit Add	ROM #1				ROM #2			
	4	3	2	1	4	3	2	1
4	1	0	0	0	0	0	0	0
5	1	0	0	0	0	0	0	0
6	0	1	0	1	0	0	0	0
7	0	0	0	0	0	0	0	0

Load Address
0200
Load Ext. Add 0
and Start

NOTE: Logic one (1) = +3V

Bootstrap example:

Bit Add	ROM #1				ROM #2			
	4	3	2	1	4	3	2	1
124	1	0	0	0	0	0	0	0
125	0	0	0	1	0	0	1	1
126	0	1	0	0	0	0	0	0
127	0	0	1	1	1	1	1	1
130	0	0	1	0	0	1	0	0
131	0	0	0	0	0	0	0	0
132	0	0	1	0	1	1	0	1
133	1	1	1	0	0	1	0	1
134	0	0	1	0	0	0	0	0
135	0	0	0	1	0	0	1	1
136	0	0	1	0	1	1	1	1
137	1	0	1	0	1	0	0	0
140	0	0	1	0	1	0	1	0
141	0	0	0	1	0	1	0	0
142	0	0	1	0	1	1	0	1
143	1	1	0	1	1	0	1	1
144	0	0	1	0	1	0	1	0
145	0	0	0	1	1	0	0	1
146	1	0	0	1	0	0	0	0
147	0	0	0	1	0	1	0	0

Load Add 0023
Load Ext Add 7
Dep 2000
Dep 6745
Dep 0023
Dep 7650
Dep 5024
Dep 6733
Dep 5031
Load Add 24 & Start

TITLE ROM PROGRAMMING DIRECTIONS FOR 8A OPTION BOARD #2 KM8-AD (M8317-YC)

5. ROMs

Unprogrammed ROMs should be purchased by the user from Digital Equipment Corporation. The part number for an unprogrammed 256 x 4 ROM is 23-000A2.