

DIGITAL EQUIPMENT CORPORATION MAYNARD, MASSACHUSETTS				
ENGINEERING SPECIFICATION			DATE 11/19/74	
TITLE FIELD INSTALLATION & ACCEPTANCE PROCEDURE FOR KM8-A				
REV	DESCRIPTION	REVISIONS		
		CHG NO	ORIG	DATE
APPD BY	DATE	DATE	DATE	DATE

ENG *James Nash* 11/19/74 APPD *Paul D. ...*
 DEC 16-10221-1022-N370
 DRA 108

DEC FORM NO 16-10221-1022-N370
DRA 108

SHEET 1 OF 3

ENGINEERING SPECIFICATION				
TITLE FIELD INSTALLATION & ACCEPTANCE PROCEDURE FOR KM8-A				
1	GENERAL	<p>This procedure defines the performance standards required of the KM8A*, option board #2. This procedure refers to both system and add-on acceptance.</p> <p>NOTE: If KM8A was shipped as part of a PDP-8A system, then proceed to installation procedure.</p> <p>* Memory Extension & Time Share Bootstrap Loaders Power Fail/Auto Restart</p>		
	II INSPECTION	<p>After removing the KM8A from the packing material, inspect the module for the following:</p> <ol style="list-style-type: none"> Inventory hardware against shipping list. Inventory software against software list, if ordered. Inventory prints against shipping list, if ordered. Check module for loose or broken components. 		
	III INSTALLATION PROCEDURE	<p>Install the equipment using the following procedure:</p> <ol style="list-style-type: none"> Set the switches as indicated by the diagnostic write up. <p>NOTE: Refer to Operator's Handbook for switch setting descriptions.</p> <ol style="list-style-type: none"> Insure that the PDP-8A power is removed from the Omnibus™. Insert the KM8A into the second or third slot of the Omnibus™. Turn the power back "ON". 		
	IV ACCEPTANCE PROCEDURE	<p>Perform the acceptance procedure defined in Table A. If abnormal indications are encountered, refer to the diagnostic listing for the type of error. Reference the diagnostic write ups and Operator's Manual for instructions for loading diagnostics.</p>		

DEC FORM NO 16-10221-1022-N370
DRA 108

SHEET 2 OF 3

ENGINEERING SPECIFICATION				
TITLE FIELD INSTALLATION & ACCEPTANCE PROCEDURE FOR KM8-A				
IV	ACCEPTANCE PROCEDURE (continued)	<p>Equipment required:</p> <ol style="list-style-type: none"> PDP-8A with 1K min. R/W Memory Paper Tape Input Device Diagnostic and Listings Programmer's Console (KC8-A & DAC8-A) K987 Quad Extender <p>NOTE: If the programmer's console and paper tape input device are not available as part of the system being used, they must be supplied in good working order by the customer.</p>		
TABLE A				
Acceptance of KM8A with 4K of R/W Memory				
Program Name	Maindec #	Accept Time	Restrictions	
KM8A Option Test #2	08-DJKMA-PB	30 min	4K R/W Memory Min	
Acceptance of KM8A with Less than 4K R/W Memory				
KM8A Option Test #2 Segment #1 (RIM)	08-DJKMA -PM1	10 min	1K R/W memory min	
KM8A Option Test #2 Segment #2 (RIM)	08-DJKMA -PM2	10 min	1K R/W Memory Min	
KM8A Option Test #2 Segment #4 (RIM)	08-DJKMA -PM4	10 min	1K R/W Memory Min	

DEC FORM NO 16-10221-1022-N370
DRA 108

SHEET 3 OF 3

"THIS DRAWING AND SPECIFICATIONS HEREIN ARE THE PROPERTY OF DIGITAL EQUIPMENT CORPORATION AND SHALL NOT BE REPRODUCED OR COPIED OR USED IN WHOLE OR IN PART AS THE BASIS FOR THE MANUFACTURE OR SALE OF ITEMS WITHOUT WRITTEN PERMISSION. COPYRIGHT © 1977 DIGITAL EQUIPMENT CORPORATION"

5 158A2/159A2 500 2

BOOTSTRAP/AUTO RESTART FUNCTIONAL SWITCH SETTINGS

DESIRED FUNCTION	ACTIVATING SIGNAL	S1-4	S1-5	S1-6	S1-7	S1-8	S2-1
BOOTSTRAP ENABLED	"BOOT" SW	*	↑	OFF	OFF	ON	N/A
AUTO-RESTART DISABLED	N/A						
BOOTSTRAP ENABLED	"BOOT" SW	*		ON	ON	ON	N/A
AUTO-RESTART ENABLED	"AC LOW"						
BOOTSTRAP DISABLED	N/A	*	SPARE	ON	ON	OFF	N/A
AUTO-RESTART ENABLED	"AC LOW"						
BOOTSTRAP ENABLED	"AC LOW"	*		ON	OFF	OFF	N/A
AUTO-RESTART DISABLED	N/A						
BOOTSTRAP ENABLED	"AC LOW" OR "BOOT" SW	*		ON	OFF	ON	N/A
AUTO-RESTART DISABLED	N/A						
TIME SHARE DISABLED	N/A	N/A	N/A	N/A	N/A	N/A	ON
TIME SHARE ENABLED	N/A	N/A	N/A	N/A	N/A	N/A	OFF

NOTES:

- * S1-4 "OFF" - BOOTSTRAP CAN BE ACTIVATED BY "BOOT" SW EITHER IN THE "RUN" OR "STOPPED" STATE
- S1-4 "ON" - BOOTSTRAP CAN ONLY BE ACTIVATED BY "BOOT" SW IN THE "RUN" STATE
- 1. "AC LOW" WILL CAUSE AUTO-RESTART OR BOOTSTRAP, DEPENDING ON SWITCH SETTINGS, TO OCCUR ONLY IN THE "RUN" OR STOPPED STATE
- S1-6, 7, 8 "OFF" - BOOTSTRAP & AUTO-RESTART DISABLED
- 2. E76 & E81 ARE NOT ON THE VC VARIATION KMB-AD. ALL OTHER PARTS REMAIN THE SAME
- 3. IF AUTO-RESTART IS ENABLED, THE AUTO-START FEATURE OF THE CPU (M8315) MUST BE DISABLED

BOOTSTRAP SELECT SWITCH SETTINGS FOR 158A2/159A2 ROMS

PROGRAM	S2-5	S2-6	S2-7	S2-8	S1-1	S1-2	S1-3	ROM ST ADD	MEM ADD START
HI-LO PTRDR	ON	ON	ON	OFF	ON	ON	ON	20	7734
RKBE	ON	OFF	ON	OFF	ON	OFF	ON	124	24
RXBE	ON	OFF	OFF	ON	OFF	ON	ON	150	33
RFDB/DFB2P	OFF	ON	OFF	ON	OFF	ON	OFF	252	7750
TABE	OFF	ON	OFF	OFF	OFF	ON	OFF	272	4000

- 3. BOOTSTRAP SELECT SWITCHES ARE DEFINED AS FOLLOWS:
- (a) ROM ADDRESS RANGE: 0-377
- (b) ON = LOGIC 0 OR LOW; OFF = LOGIC 1 OR HIGH
- (c) ORDER OF SIGNIFICANCE
- $S_2 5 = 2^7 = 200$ (MSB)
- $S_2 6 = 2^6 = 100$
- $S_2 7 = 2^5 = 40$
- $S_2 8 = 2^4 = 20$
- $S_1 1 = 2^3 = 10$
- $S_1 2 = 2^2 = 4$
- $S_1 3 = 2^1 = 2$

THE LSB OF ADDRESS IS CONTROLLED BY THE BOOTSTRAP/AUTO-RESTART LOGIC

BOOTSTRAP SELECT SWITCH SETTINGS FOR 465A2/469A2 ROMS

PROGRAM	S2-5	S2-6	S2-7	S2-8	S1-1	S1-2	S1-3	ROM ST ADD	MEM ST ADD
HI-LO PTR	ON	ON	ON	OFF	ON	ON	ON	20	7734
RKBE	ON	OFF	ON	OFF	ON	OFF	ON	124	24
RXBE	ON	OFF	OFF	ON	OFF	ON	ON	150	33
RLRA	OFF	ON	OFF	OFF	OFF	ON	OFF	272	1

* RXBE BOOT FOR BOTH RX01 AND RX02

FOR BOTH 158A2/159A2 & 465A2/469A2 ROMS

AUTO-RESTART SELECT SWITCH SETTINGS

RESTART ADDRESS	S2-2	S2-3	S2-4
0	OFF	OFF	OFF
2000	OFF	ON	OFF
2000	ON	OFF	OFF
4200	ON	ON	OFF

- 4. AUTO-RESTART SELECT SWITCHES ARE DEFINED AS FOLLOWS:
- (a) ROM ADDRESS RANGE: 0-16
- (b) ON = LOGIC 1 OR LOW; OFF = LOGIC 0 OR HIGH
- (c) ORDER OF SIGNIFICANCE
- $S_2 2 = 2^3 = 10$
- $S_2 3 = 2^2 = 4$
- $S_2 4 = 2^1 = 2$

5. TO CONFIGURE MODULE FOR USE WITH KT8-A OPTION, INSTALL JUMPERS AS SHOWN BELOW

	W1	W2	W3	W4
NORMAL	IN	OUT	OUT	OUT
WITH KT8A	OUT	IN	IN	IN

COMPONENT SUBSTITUTION CHART

PART CALLED FOR		SUBSTITUTE PART			
QTY	PART NO.	DESCRIPTION	QTY	PART NO.	DESCRIPTION
96	1001610-01	0147FD DISC	96	1001610-00	0147FD GLASS
3	15C3100	DEC 3000B	3	1509338	DEC 6531
6	1911330	74173	6	1911711	8T10
1	1909704	314	1	1910391	5314
			1	1909972	6314
			1	1910389	7314
6	1909705	8881	6	1909973	97401
1	23158A2	ROM 1 (E76)	1	23465A2	ROM 1 (E76)
1	23159A2	ROM 2 (E81)	1	23469A2	ROM 2 (E81)

QTY	REF. DESIGNATION	DESCRIPTION	PART NO.	ITEM NO.
12	12	INSULATED, JUMPER WIRE	9009185	02
1	1	EYELET, HANDLE	9800024-01	53
1	1	HANDLE ASSY	1210711-02	54
1	1	RES. 470Ω 1/4W 5%	1300316	55
1	1	CAP. 0.022MF 50V 10%	1011683	56
1/2	1/2	THIN WALL TUBING	9107256-11	57

PARTS LIST

QTY	QTY	REF. DESIGNATION	DESCRIPTION	PART NO.	ITEM NO.
			OPTION BOARD #2	M8317-YB-1	S _A

CHK	CHANGE NO.	REV.

REV. 3
M8317-YB-1
D CS

THIS DRAWING AND SPECIFICATIONS HEREIN ARE THE PROPERTY OF DIGITAL EQUIPMENT CORPORATION AND SHALL NOT BE REPRODUCED OR COPIED OR USED IN WHOLE OR IN PART AS THE BASIS FOR THE MANUFACTURE OR SALE OF ITEMS WITHOUT WRITTEN PERMISSION. COPYRIGHT © 1977 DIGITAL EQUIPMENT CORPORATION

S 1-BX-2119N 10021375 2

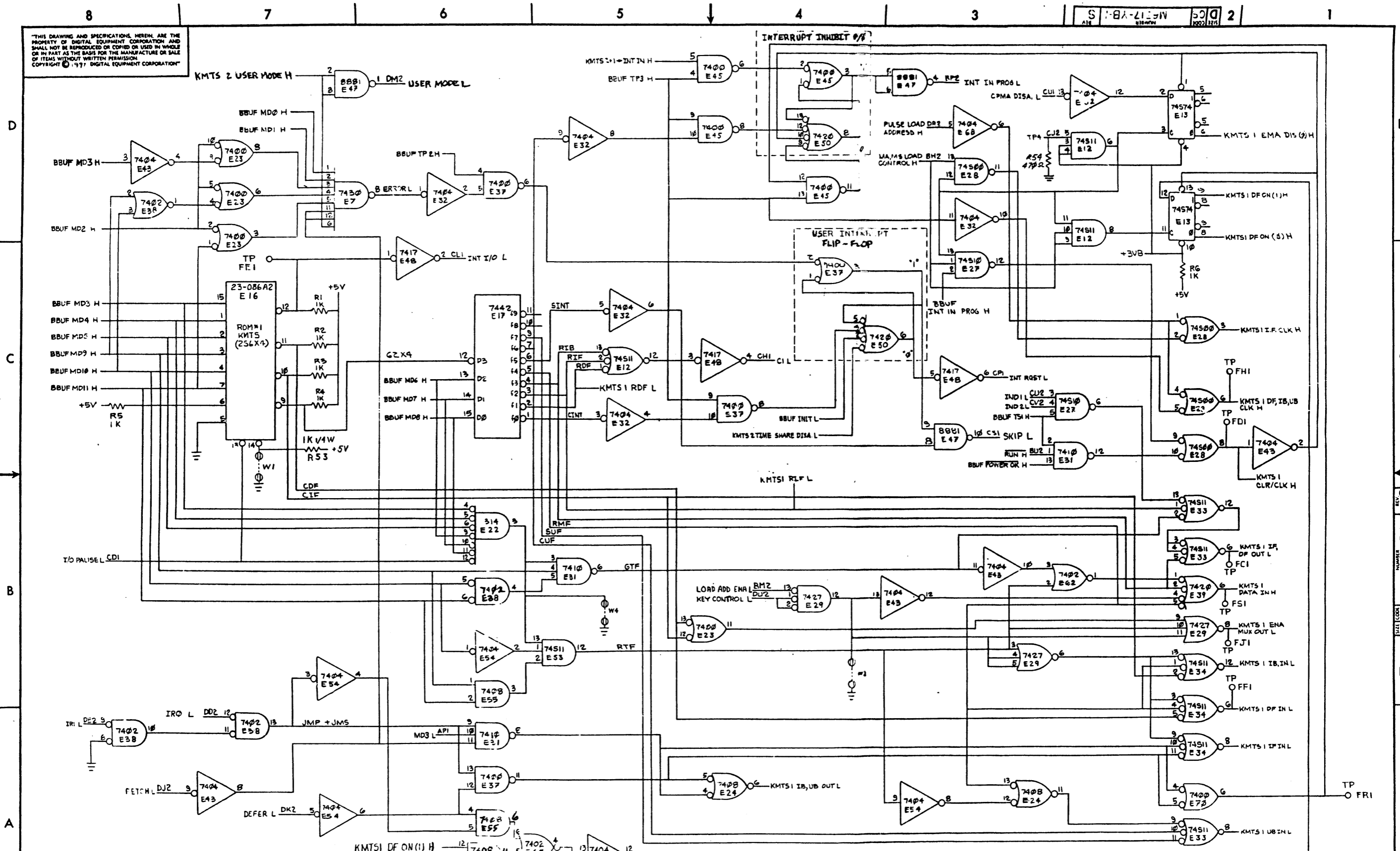

REVISIONS		
CHK	CHANGE NO.	REV.

MEMORY EXT/TIME SHARE REGISTER CONTROL

TITLE	OPTION BOARD #2 (KMTS 1)	SIZE/CODE	D 05	NUMBER	MB317-Y9-1	REV.	S
SCALE	NONE	SHEET	3	OF	7	DIST.	

