

LA36/LA35 DECwriter II User's Manual

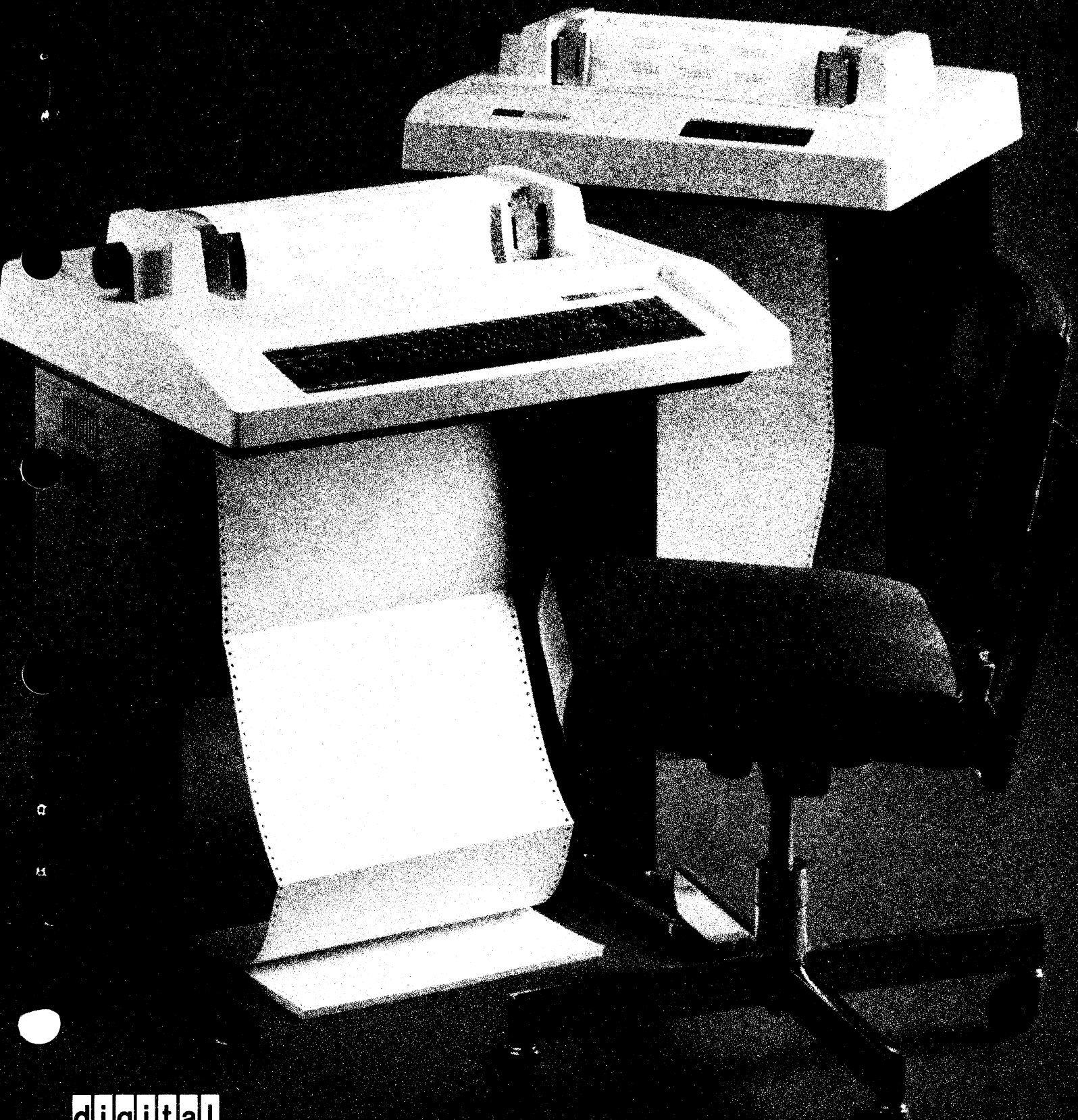

digital

1st Printing, November 1975
2nd Edition, February 1976

Copyright © 1975, 1976 by Digital Equipment Corporation

The material in this manual is for informational purposes and is subject to change without notice.

Digital Equipment Corporation assumes no responsibility for any errors which may appear in this manual.

Printed in U.S.A.

For additional copies of this document, specify Order No.: EK-LA3635-OP-002

The following are trademarks of Digital Equipment Corporation, Maynard, Massachusetts:

FLIP CHIP	DECtape
UNIBUS	DECsystem-10
PDP	DECmagtape
DECUS	DIGITAL
DEC	

DECWRITER II

TABLE OF CONTENTS

	Page
SECTION 1 LA36 USER'S INFORMATION	
LA36 GENERAL INFORMATION	1-1
Introduction	1-1
Options	1-1
LA36 DECwriter Model Variations	1-3
LA36 Jumper Configurations	1-3
LA36 Specifications	1-4
LA36 OPERATOR'S GUIDE	1-5
LA36 Operator Controls and Indicators	1-5
Using the LA36	1-11
LA36 INSTALLATION AND CHECKOUT GUIDE	1-12
General Installation Information	1-12
Unpacking and Repacking	1-12
Checkout and Acceptance Procedures	1-12
CONTROLS AND INDICATORS FOR LA36 OPTIONS	1-14
Forms Control Option (LAXX-KV)	1-14
Forms Control, Vertical Tabulation, and Horizontal Tabulation Option (LAXX-KY)	1-14
Scale, Pointer, and Window Option (LAXX-LN)	1-14
Acoustical Coupler Option (LAXX-LM)	1-14
SETUP AND OPERATING PROCEDURES FOR LA36 OPTIONS	1-15
APL Option (LAXX-PK)	1-15
Forms Control Option (LAXX-KV)	1-15
Forms Control, Vertical Tabulation, and Horizontal Tabulation Option (LAXX-KY)	1-17
Automatic Line Feed Option (LAXX-LA)	1-18
Automatic Answerback Option (LAXX-KX)	1-19

TABLE OF CONTENTS (Continued)

	Page
Selective Addressing Option (LAXX-KW)	1-19
Acoustical Coupler Option (LAXX-LM)	1-24
INSTALLATION AND CHECKOUT OF LA36 OPTION KITS	1-25
Introduction	1-25
Expander Option Mounting Kit (LAXX-LB)	1-25
APL Option Kit (LAXX-PK)	1-26
Forms Control Option Kit (LAXX-KV)	1-32
Forms Control, Vertical Tabulation, and Horizontal Tabulation, Option Kit (LAXX-KY)	1-34
Automatic Line Feed Option Kit (LAXX-LA)	1-36
Selective Addressing Option Kit (LAXX-KW)	1-37
Automatic Answerback Option Kit (LAXX-KX)	1-40
EIA Interface Option Kit (LAXX-LG)	1-42
14-Key Numeric Pad Option Kit (LAXX-KE)	1-42
Compressed Font Option Kit (LAXX-KJ)	1-44
Paper Out Option Kit (LAXX-KZ)	1-46
20 mA Cable Option Kit (LAXX-LH)	1-49
20 mA (DEC 10) Cable Option Kit (LAXX-LK)	1-49
Scale, Pointer, and Window Option Kit (LAXX-LN)	1-52
DF11 Adaptor Kit (LAXX-KH)	1-54
Acoustical Coupler Option Kit (LAXX-LM)	1-54
 SECTION 2 LA35 USER'S INFORMATION	
LA35 GENERAL INFORMATION	2-1
Introduction	2-1
Options	2-1
LA35 DECwriter Model Variations	2-2
LA35 Jumper Configurations	2-2
LA35 Specifications	2-3
LA35 OPERATOR'S GUIDE	2-4
LA35 Operator Controls and Indicators	2-4
Using the LA35	2-6
LA35 INSTALLATION AND CHECKOUT GUIDE	2-7
General Installation Information	2-7
Unpacking and Repacking	2-7
Checkout and Acceptance Procedures	2-7
CONTROLS AND INDICATORS FOR LA35 OPTIONS	2-9
Forms Control Option (LAXX-KV)	2-9
Forms Control, Vertical Tabulation, and Horizontal Tabulation Option (LAXX-KY)	2-9
Scale, Pointer, and Window Option (LAXX-LN)	2-9
Acoustical Coupler Option (LAXX-LM)	2-9
SETUP AND OPERATING PROCEDURES FOR LA35 OPTIONS	2-10
APL Option (LAXX-PK)	2-10
Forms Control Option (LAXX-KV)	2-10
Forms Control, Vertical Tabulation, and Horizontal Tabulation Option (LAXX-KY)	2-10

TABLE OF CONTENTS (Continued)

	Page
Automatic Line Feed Option (LAXX-LA)	2-12
Automatic Answerback Option (LAXX-KX)	2-13
Selective Addressing Option (LAXX-KW)	2-13
Acoustical Coupler Option (LAXX-LM)	2-17
INSTALLATION AND CHECKOUT OF LA35 OPTION KITS	2-18
Introduction	2-18
Expander Option Mounting Kit (LAXX-LB)	2-18
APL Option Kit (LAXX-PK)	2-21
Forms Control Option Kit (LAXX-KV)	2-21
Forms Control, Vertical Tabulation, and Horizontal Tabulation Option Kit (LAXX-KY)	2-24
Automatic Line Feed Option Kit (LAXX-LA)	2-27
Selective Addressing Option Kit (LAXX-KW)	2-27
Automatic Answerback Option Kit (LAXX-KX)	2-30
EIA Interface Option Kit (LAXX-LG)	2-32
Compressed Font Option Kit (LAXX-KJ)	2-32
20 mA Cable Option Kit (LAXX-LH)	2-36
20 mA (DEC 10) Cable Option Kit (LAXX-LK)	2-36
Scale, Pointer, and Window Option Kit (LAXX-LN)	2-39
DF11 Adaptor Kit (LAXX-KH)	2-41
Acoustical Coupler Option Kit (LAXX-LM)	2-41
 SECTION 3 COMMON INFORMATION	
LOADING PAPER AND CHANGING THE RIBBON	3-1
Loading Paper	3-1
Loading New Forms	3-1
Paper Positioning Procedure	3-1
Impression Adjustment	3-4
Horizontal Positioning Adjustment	3-5
Fine Vertical Positioning	3-5
Reloading Paper	3-6
Ribbon Installation	3-7
DECwriter Interface Information	3-10
Interface Description	3-10
Interface Specifications	3-10
PROGRAMMER'S GUIDE	3-11
LA36 Programmer's Information	3-11
Transmitting Characters and Commands	3-11
Special Command Keys	3-11
Receiving Characters and Commands	3-11
OPERATOR CARE, PACKING, AND REPACKING	3-16
Operator Care	3-16
Unpacking and Inspection	3-16
Packing Procedure	3-18
TROUBLESHOOTING GUIDE	3-19

PREFACE

The LA36/LA35 is a simple, dependable addition to your company's processing system. It has been designed to maintain optimum performance for many years while keeping maintenance at a minimum.

This user's manual is a guide to the simple procedures required to operate your LA36/LA35. However, to ensure crisp copies and maximum equipment life, the user must adhere to the following:

- Perform the impression adjustment (when required) as described in this manual.
- Replace the ribbon (when required) only with DIGITAL-recommended ribbons.

NOTE

This manual is applicable to the following model DECwriters:

LA36-CE	LA36-DJ
LA36-CF	LA35-CE
LA36-CH	LA35-CF
LA36-CJ	LA35-CH
LA36-DE	LA35-CJ
LA36-DF	LA35-DE
LA36-DH	LA35-DJ

NOTE

All octal codes used throughout this manual refer to 7-bit ASCII.

- Product Repair Centers (PRCs) – You may send or bring equipment to a PRC for repair or replacement under one of the following plans:
 - Major Repair Work – On a time and material basis.
 - Fixed Quote Repair – Return equipment to PRC. After inspection, we will contact you with a fixed price for repair. If you choose not to have it repaired, a handling fee will be charged.
 - PRC Contract – Repairs at the PRC on a contractual basis.
- Module Repair – Available through the PRCs in Maynard, Canada, Holland, Japan, and Australia.
 - Loose Piece Module Repair – Repair of DECWRITER II modules on a fixed price basis. Turn-around is usually 22 working days.
 - Module Mailer Program – A subscription approach to module repair. For a minimum of \$2,000, the customer may return his DECWRITER II modules and be guaranteed a turn-around of 7 working days. This program enables you to significantly reduce your spares inventory.

Spare Parts: DIGITAL's Customer Spares group offers support to our customers performing any level of DECWRITER II maintenance. Available through this group is:

- Spare parts, spares kits, tools, and test equipment.
- Recommended spares listings developed specifically for your need and equipment. This service is at no charge.
- Maintenance documentation.
- Emergency parts service.

Training: Educational Services offers hardware maintenance courses for your DECWRITER II. Available at 14 worldwide training centers and at the customer site.

LOCATIONS OF PRODUCT REPAIR CENTERS:

North America:

Chicago	Princeton
Maynard	Santa Ana
Ottawa	Sunnyvale

Europe:

Belgium	U.K.
France	Sweden
Holland	Switzerland
Italy	West Germany

General International Area:

Australia
Japan

**INSTALLATION
REGISTRATION
CARD**

FIRST CLASS PERMIT NO. 33 MAYNARD, MASS.

Digital Equipment Corporation
146 Main Street
Maynard, Massachusetts 01754
Attn: Customer Services Marketing PK3-2 S-24

DECWRITER II Installation Card

SECTION 1
LA36 USER'S INFORMATION

LA36 GENERAL INFORMATION

INTRODUCTION

The LA36 DECwriter II is a medium-sized, low-cost, interactive data communications terminal. It is designed as an input/output device that can be used as a system command console or as a remote communications terminal.

The LA36 incorporates a low-speed impact printer for hard copy output and a standard ASCII keyboard for transmitting data to the host system or to another data communication terminal(s).

The printer is capable of handling multipart and multi-form line printer paper from 3 to 14-7/8 in. (7.62 to 37.78 cm) wide.

Preprinted forms can be positioned for the best print-to-line-positioning incidence through the use of the manual vernier paper advance adjustment.

The keyboard is a standard ASCII-coded keyboard, consisting of alphanumeric characters and nonprinting system control codes. The ASCII code set consists of upper and lower case characters and prints at a horizontal spacing of 10 characters per inch and a vertical spacing of 6 lines per inch. The CAPS LOCK switch on the keyboard allows selection of a reduced number of ASCII characters.

OPTIONS

The basic LA36 DECwriter II can be expanded to provide the user with a number of functional options for receiving, transmitting, and handling data. These functional options are described in the following table.

LA36 Options

Options	Name	Control Switch/Indicator	Description
LAXX-LB	Expander Option	None	The Expander Option Mounting Kit includes the logic, cables, and mounting hardware required to expand the LA36 to include options LAXX-LA, LAXX-KV, LAXX-KW, LAXX-KX, LAXX-KY, and LAXX-PK.
LAXX-PK	APL/ASCII Dual Character Set	ALT CHAR SET, CHAR SET LOCK, and STD/ALT CHARACTER SET Indicators	This option provides an APL alternate character set for use with the standard character set in the LA36.
LAXX-LA	Auto LF After CR	AUTO LF	When the AUTO LF switch is activated, the printer will automatically insert a line feed after each carriage return code typed during transmission. The LAXX-LA option can also be configured to execute a line feed after each received carriage return code. Any combination of these options can be used.

LA36 Options (Cont)

Options	Name	Control Switch/Indicator	Description
LAXX-KV	Top of Forms Control	FORMS LENGTH Switch and SET TOP OF FORM Push-button	Controls mounted under the top cover provide the operator with a method of selecting the length of the paper to be used. After the desired setting is selected and the paper is lined up for proper vertical alignment, the operator presses the SET TOP OF FORM switch so that the internal logic will be preset to the paper length defined by the operator.
LAXX-KW	Selective Addressing	DEVICE SELECT and SELECT AVAIL Lamps	The Selective Addressing Option allows the LA36 to communicate with other terminals on a single data communications channel.
LAXX-KX	Auto Answerback and Auto LF Options	HERE IS, AUTO LF	The Automatic Answerback Option allows the terminal to transmit a preprogrammed message of 20 characters (maximum). The message is initiated by pressing the HERE IS pushbutton, or upon receipt of the ENQ control code from another device. The LAXX-KX also incorporates the features of the Auto LF option (LAXX-LA).
LAXX-KY	Forms Control and Vertical and Horizontal Tabs	Keyboard Keys	The Forms and Tabbing Option enables the terminal to set horizontal and vertical tab positions either locally or via the system software. This option also incorporates features of the Top of Forms option (LAXX-KV) and operates in the same manner.
LAXX-LG	EIA/CCITT Interface	None	The LAXX-LG interface provides the user with an RS/232-C interface with modem control and includes a 9-ft (3.4-m) cable terminated with a standard EIA connector.
LAXX-KH	DF11 Mounting Kit	None	The DF11 Mounting Kit enables the user to mount one of the DIGITAL series DF11 communication options in the LA36.
LAXX-KJ	Compressed Font Option	None	The Compressed Font Option is a mechanical option that provides the LA36 with the ability to print 132 columns on a form 8-1/2 in. (21.59-cm) wide.
LAXX-KE	14-Key Numeric Keypad	Keyboard Keys	The 14-key numeric keypad is located to the right of the keyboard and provides the operator with a convenient method of entering mathematical number sequences.

LA36 Options (Cont)

Options	Name	Control Switch/Indicator	Description
LAXX-KZ	Paper Out	PAPER OUT Lamp	Provides a visual indication for a paper-out condition. Prevents keyboard and received data from printing.
LAXX-LC	TTL to CCITT (V28) Converter and Modem Protector	None	The TTL to CCITT (V28) Converter and Modem Protector is a BPO DATEL services interface that meets the requirements of CCITT (V28) with BPO-required modem protection circuitry.
LAXX-LH	Current Loop Cable	None	20 mA current loop with Mate-N-Lok.
LAXX-LK	Current Loop Cable	None	20 mA current loop with 4-pin plug for DEC10.
LAXX-KG	EIA Interface	None	The LAXX-LG interface includes a 9-ft (3.54-m) cable terminated with a standard EIA connector (no modem control features).
LAXX-LN	Scale, Pointer, and Window Kit	Column scale, Line Indicator, and Column Pointer	Operator convenience items that assist in positioning the print head on preprinted forms and in locating horizontal tabs.

LA36 DECwriter MODEL VARIATIONS

The LA36 variations and associated model numbers are listed below.

LA36-CE	LA36 with Numeric Pad and Paper Out	60 Hz, 90–132 V
LA36-CF	LA36 with Numeric Pad and Paper Out	60 Hz, 180–264 V
LA36-CH	LA36 with Numeric Pad and Paper Out	50 Hz, 90–132 V
LA36-CJ	LA36 with Numeric Pad and Paper Out	50 Hz, 180–264 V
LA36-DE	LA36	60 Hz, 90–132 V
LA36-DF	LA36	60 Hz, 180–264 V
LA36-DH	LA36	50 Hz, 90–132 V
LA36-DJ	LA36	50 Hz, 180–264 V

LA36 JUMPER CONFIGURATIONS

LA36 Optional Current Loop Configuration

The LA36 is normally configured for full-duplex passive operation. To modify this configuration for full-duplex

active, half-duplex active, or half-duplex passive, jumpers on the logic board must be changed. For a detailed description of these jumper modifications and the associated cabling required, refer to the *LA36 DECwriter II Maintenance Manual*.

LA36 Parity

The LA36 is normally configured with no parity, 8th bit marking on transmit, and no parity error printout. To modify this configuration for 8th bit on transmit or odd or even parity with or without error printout, jumpers on the logic board must be changed. For a detailed description of these jumper modifications, refer to the *LA36 DECwriter II Maintenance Manual*.

LA36 Speaker (Bell) Volume

The LA36 can be configured for a lower speaker volume by removing a jumper. For a description of this jumper modification, refer to the *LA36 DECwriter II Maintenance Manual*.

LA36 SPECIFICATIONS

Printing

Switch selectable: 10, 15, or 30 characters/second throughput

Line Length

132 characters maximum

Spacing

10 characters/in. (horizontal)
6 lines/in. (vertical)

Characters

96 upper/lower case ASCII
7 X 7 dot matrix (0.07 X 0.10 in.) (1.77 X 2.54 mm)

Paper

Variable width: 3 to 14-7/8 in. (7.62 to 37.78 cm)
Single-Part:

15 lb paper minimum
Card stock thickness of 0.010 in. (0.25 mm) maximum

Multipart:

2- to 6-part (see Notes)
Thickness of 0.020 in. (0.50 mm) maximum

Tractor-drive, pin-feed

NOTES

1. **Multipart forms may have only one card part. The card must be the last part.**
2. **NCR or 3M paper, up to 6-part, must use ribbon on top copy. First surface impact paper is not recommended.**

3. **Continuous-feed, fan-fold business forms with 3- or 4-prong margin crimps on both margins (multipart) are recommended. Stapled forms are not recommended and may damage tractors and other areas of the machine. Dot or line glue margins are acceptable (if line is on one margin only). Do not line glue both margins as air will not be able to escape and poor impressions will result.**

Keyboard

Standard ANSI keyboard layout
Multikey roll-over

Interface

Integrated 20 mA current loop, with standard or DEC10 cable or EIA/CCITT interface.

Ribbon

DIGITAL-specified nylon fabric (Part No. 36-10558)
Spool assembly: 0.5 in. (1.27 cm) wide X 40 yd (36.58 m) long

Power

90–132 Vac or 180–264 Vac
50 or 60 Hz \pm 1 Hz
300 W maximum (printing)
160 W maximum (idle)

Temperature

Operating
10° to 40° C (50° to 104° F), noncondensing
Nonoperating
–40° to 66° C (–40° to 151° F) nonoperating, noncondensing

Relative Humidity

Operating
10 to 90% with a maximum wet bulb temperature of 28° C (82° F) and a minimum dew point of 2° C (36° F), noncondensing
Nonoperating
5 to 95%

Dimensions

27.5 in. (69.85 cm) wide
33.5 in. (85.09 cm) high
24.0 in. (60.69 cm) deep

Weight

102 lb (46.36 kg)

LA36 OPERATOR'S GUIDE

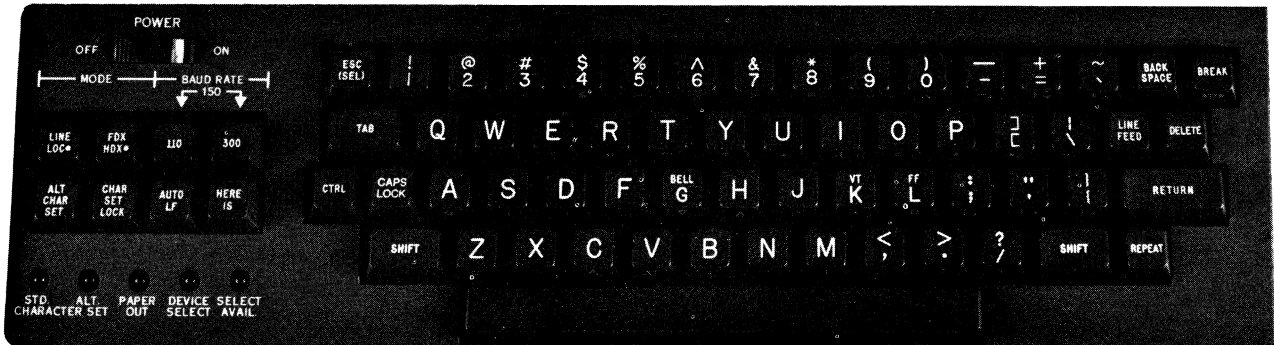

7622-28

LA36 OPERATOR CONTROLS AND INDICATORS

NOTE

Dot on switch indicates function of switch when depressed.

POWER ON/OFF Switch

The POWER ON/OFF switch connects and disconnects the line voltage to the LA36 DECwriter II. The POWER switch should be in the ON position for normal unit operation. When changing paper, ribbon, or adjusting the print head, the switch should be turned OFF.

LINE/LOC Switch

The LINE/LOC switch is a 2-position operator control switch. When in the LINE position, the LA36 is enabled to transmit and receive data. When in the LOC position, the LA36 receive/transmit lines are disabled and only local operation can be performed.

FDX/HDX Switch

The FDX/HDX switch controls the printing of transmitted keyboard characters. When in the FDX position, characters typed on the keyboard are transmitted; only received characters are printed. When in the HDX position, keyboard characters are both transmitted and printed; received characters are also printed. The operator should not attempt to transmit data when receiving data in the HDX mode.

BAUD RATE Switches

The BAUD RATE switches select the rate at which characters are transmitted and received over the communication line.

Switch	Character Rate
110	10 (characters/second)
300	30 (characters/second)
110 and 300	15 (characters/second)

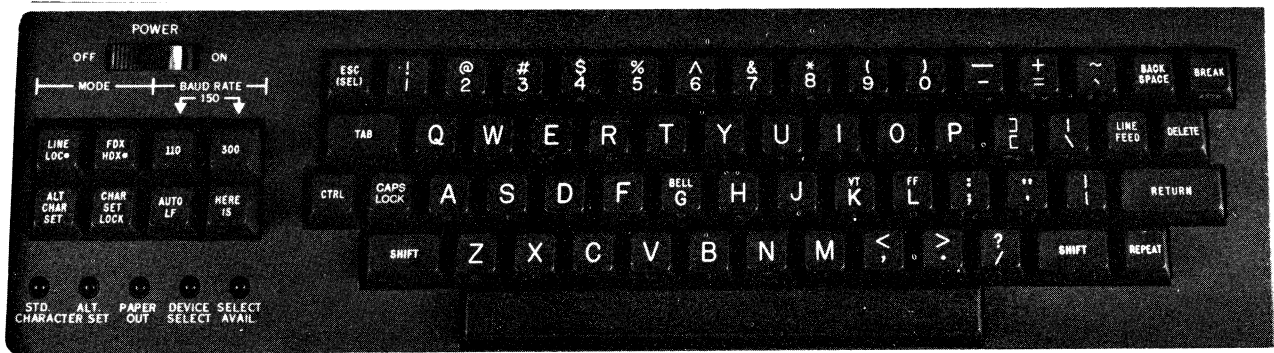

7622-28

ALT CHAR SET Switch

When an alternate character set is installed, the ALT CHAR SET switch allows the operator to select either the standard ASCII character set (switch up) or the alternate character set (switch down).

CHAR SET LOCK Switch

The CHAR SET LOCK switch allows the operator to select manual (switch down) or automatic (switch up) character set switching. In the automatic mode, the transmitting device can change the character set by issuing the character codes Switch In (control-O) or Switch Out (control-N). The Switch In code selects the standard ASCII character set. The Switch Out code selects the alternate character set. In the manual mode, the character set is selected by the ALT CHAR SET control switch.

STD/ALT CHARACTER SET Indicators

The STD/ALT CHARACTER SET indicators give a visual indication of the selected character set. If no alternate character set option is installed, the STD indicator will always be illuminated when power is on.

AUTO LF Switch

The AUTO LF switch is an optional operator control that is inoperative unless option LAXX-LA or LAXX-KX is installed in the LA36. When either option

is installed and the AUTO LF switch is enabled, a LF control code will be transmitted each time a carriage return code is transmitted.

HERE IS Switch

The HERE IS switch is an optional operator control that is inoperative unless option LAXX-KX is installed in the LA36. When the LAXX-KX is installed, depressing the HERE IS switch will cause a 20-character preprogrammed message to be transmitted.

PAPER OUT Indicator

When illuminated, the PAPER OUT indicator gives a visual indication that the LA36 is out of paper. Printing stops when the out of paper condition is detected.

DEVICE SELECT Indicator

The DEVICE SELECT indicator, when illuminated, gives a visual indication that the LA36 has been selected as a slave terminal and can transmit data back to the transmitting unit. This indicator is only operative when Selective Addressing option LAXX-KW is installed in the LA36.

SELECT AVAIL Indicator

The SELECT AVAIL indicator gives a visual indication that the data communication channel is available and that the LA36 has the ability to initiate data transmission. This indicator is only operative when Selective Addressing option LAXX-KW is installed in the LA36.



7622-28

CTRL Key

The CTRL key provides the LA36 operator with a method of transmitting ASCII control codes (000_8-037_8). Holding the CTRL key down and pressing any alphanumeric key or control key changes the standard alphanumeric ASCII code for that key to a control code (000_8-037_8).

CAPS LOCK Key

The 26 letter keys transmit only upper case when the CAPS LOCK switch is down. None of the other keys are affected.

SHIFT Key

This is a momentary switch which, when depressed, allows selection of uppercase for all printable characters.

TAB Key

The printer does not respond to TAB (code 011_8) unless option LAXX-KY is installed.

ESC (SEL) Key

The ESC (SEL) key generates code 033_8 . This provides the LA36 operator with a convenient method of generating an escape command code sequence. The printer does not respond to the escape code unless option LAXX-KY is installed.

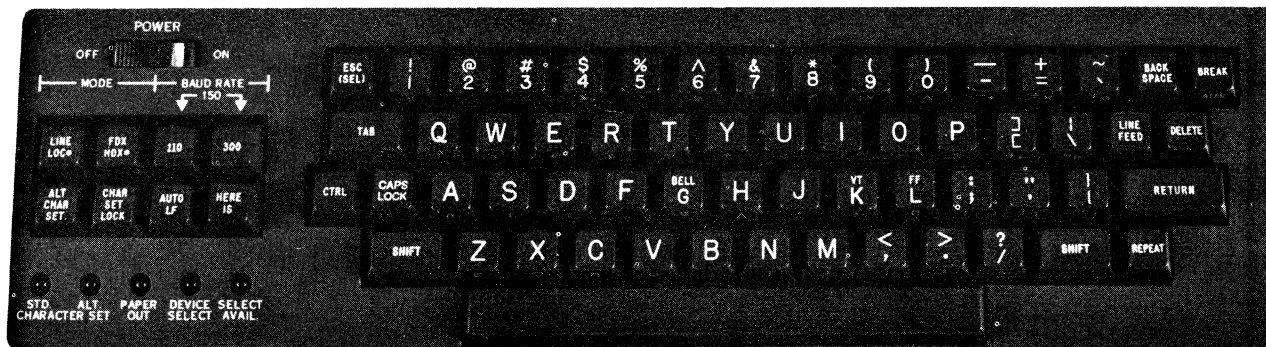

7622-28

REPEAT Key

The REPEAT key does not generate an ASCII code. However, when the REPEAT key is held down and any key is depressed, it causes the ASCII code for that character to be transmitted and printed at a repetition rate of approximately 15 characters/second (until the key is released).

RETURN Key

The RETURN key generates code 015₈. The printer control logic causes the print head to be repositioned to the left-hand margin each time the carriage return character code is received. If a line feed (LF) character code follows the carriage return code, the line feed operation is executed simultaneously with the carriage return. With options LAXX-LA or LAXX-KX installed, the capability of adding a line feed command after the carriage return is included.

LINE FEED Key

The LINE FEED key generates code 012₈. The printer will advance the paper one line each time the LF code is received.

NOTE

Rapid paper advance can be obtained by placing the LA36 in the LOCAL mode and pressing the LINE FEED and REPEAT keys.

BACKSPACE Key

The BACKSPACE key generates code 010₈. The printer control logic causes the print head to move one position to the left each time a BACKSPACE code is received, until the print head reaches the left-hand margin.

DELETE Key

The DELETE key generates code 177₈. The printer does not respond to the delete code.

BREAK Key

The BREAK key is provided for users that utilize the half-duplex mode of transmission. The BREAK key allows the LA36 operator to interrupt incoming data flow by forcing the communication line from a mark mode into the space mode (until the BREAK key is released). If the LAXX-LG EIA interface is installed, a short space (230 ms) will be generated.

Carriage Adjustment Lever

The Carriage Adjustment lever controls the print head gap for single-part or multipart forms.

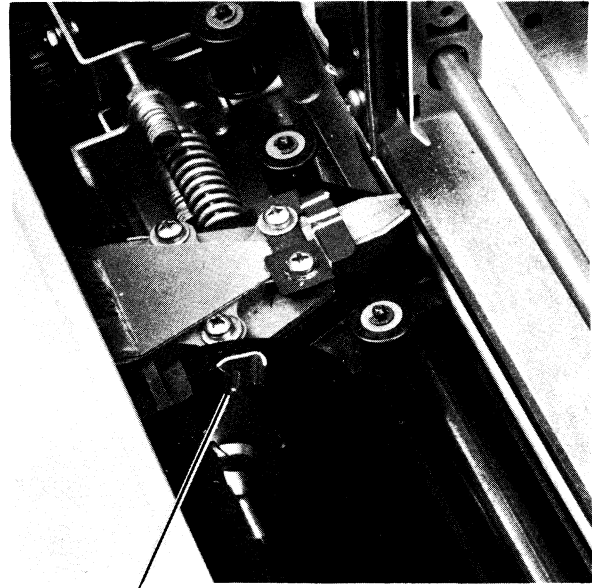

CARRIAGE
ADJUSTMENT
LEVER

7666-16

Paper Advance Knob

The Paper Advance knob pushes in to disengage the line feed gear train, allowing fine vertical adjustment of paper position. Coarse vertical adjustment is achieved by simply turning the knob. Each detent turned represents one line.

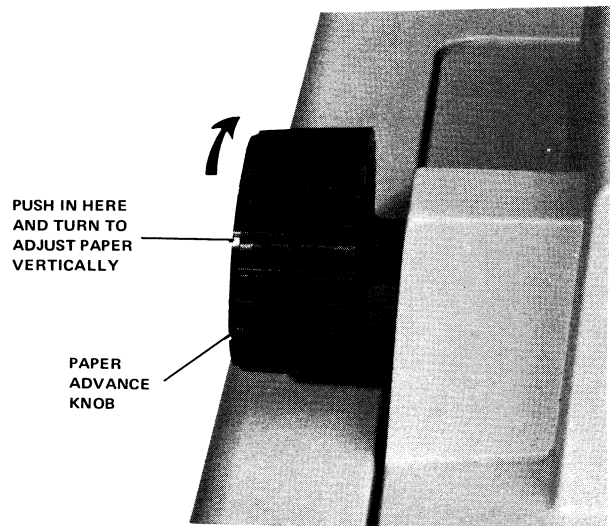

7595-4

Tractor Adjust Knob

The Tractor Adjust knob allows fine horizontal adjustment of forms.

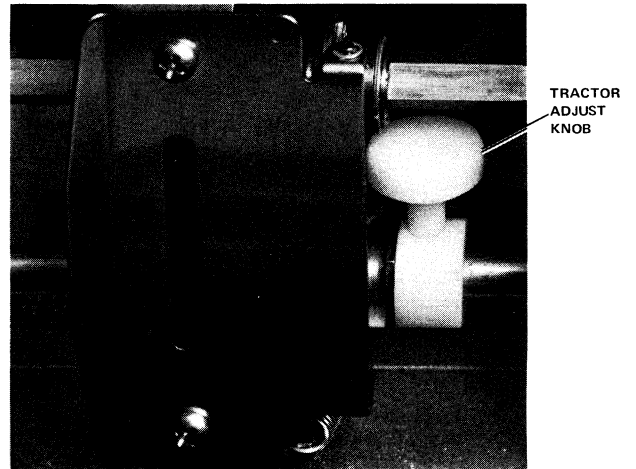

7595-7

Numeric Keypad

The numeric keypad enables numbers to be entered in an adding machine fashion. Each key in the numeric keypad generates the same ASCII character as the corresponding key in the main keyboard. The ENTER key corresponds to the RETURN key.



7622-9

Bell

The bell indicates that a bell code was received, or that the print head has reached column 64.

USING THE LA36

These steps are all that may be required to place your LA36 on-line:

1. Load paper (described in Section 3).
2. Set LINE/LOC switch to LOC.
3. Set POWER ON/OFF switch to ON.
4. Select full-duplex or half-duplex (FDX/HDX switch).
5. Select character set (ALT CHAR SET and CHAR SET LOCK switches), if applicable.
6. Select AUTO LF, if applicable.
7. Select desired baud rate (BAUD RATE switches).
8. Set the LINE/LOC switch to LINE.

The LA36 is now on-line and ready to receive and transmit data.

LA36 INSTALLATION AND CHECKOUT GUIDE

GENERAL INSTALLATION INFORMATION

This section contains the step-by-step procedures for unpacking and unit checkout to ensure that the unit was not damaged during shipment and that the unit is operating properly prior to connection to the communication system.

The LA36 DECwriter II should be installed in an area that is free of excessive dust, dirt, corrosive fumes, and vapors. To ensure that the unit has proper ventilation and cooling, the ventilation openings on the side of the cabinet should not be obstructed. A minimum 4-in. clearance between units must be maintained at all times. Adequate service clearance must also be provided for servicing the unit. (Refer to the figure on the following page.)

UNPACKING AND REPACKING

Unpack the LA36 as described in Section 3. If it becomes necessary to ship the LA36 to another site, refer to the repacking procedure described in Section 3.

CHECKOUT AND ACCEPTANCE PROCEDURES

Perform the following procedure. If the desired results are not achieved, refer to the troubleshooting guide in Section 3.

1. Install ribbon per ribbon installation procedure (Section 3).
2. Install paper per paper loading procedure (Section 3).

CAUTION

Before connecting the LA36 to a power source, ensure that the line voltage and frequency are compatible with the power requirements of the machine. Ensure that the POWER switch on the console is OFF.

3. Connect the LA36 line cord to the correct wall receptacle; press the control panel POWER switch to the ON position. The print head automatically positions itself to the left margin.
4. Set the baud rate to 300 and the LINE/LOC switch to LOC.
5. Press the LINE FEED key, hold down the CTRL key, and then press the BELL key. The stepping motor will advance the paper one line and the bell tone will sound. Type a line of characters. When the print head passes the 64th character position, the bell tone will sound.
6. Press the BACKSPACE key. The print head will move one character position to the left.
7. After 132 characters have printed, press the RETURN key and observe the return of the print head to the "home" position.
8. Set the BAUD RATE switches to the setting prescribed for the operating system.

NOTE

Both the 110 and 300 BAUD RATE switches must be depressed to obtain a baud rate of 150.

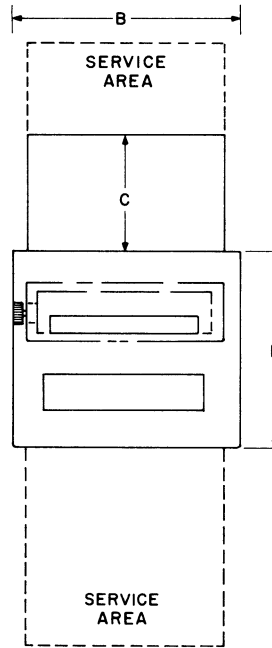
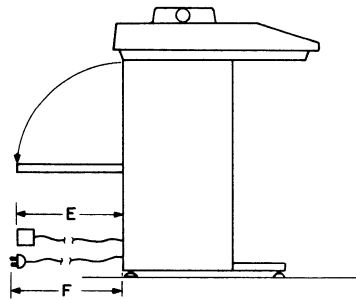
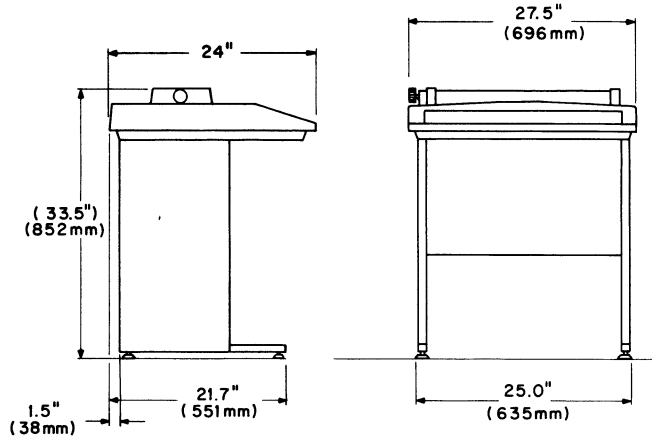

DIMENSIONS	A	B	C	D	E	F
INCHES	33.5	27.5	14	24	*	96
MILLIMETERS	852	696	356	610	*	2440

* CURRENT LOOP CABLE (BC05F) LENGTH IS 15 FT ; EIA CABLE LENGTH IS 9 FT (2744mm)

CP-2023

LA36 Site Considerations

CONTROLS AND INDICATORS FOR LA36 OPTIONS

The following options include additional controls not present on basic LA36 DECwriters.

FORMS CONTROL OPTION (LAXX-KV)

This option requires the addition of a top-of-form control assembly, which is installed beneath the top cover on the print head chassis. There are two controls on this assembly: SET TOP OF FORM and FORM LENGTH (Figure 1).

- *SET TOP OF FORM* is a pushbutton that clears the previously loaded form length and loads the current setting of the FORM LENGTH switch.
- *FORM LENGTH* is a 12-position rotary switch that is used to preset a form length (in inches) into the Forms Control.

FORMS CONTROL, VERTICAL TABULATION, AND HORIZONTAL TABULATION OPTION (LAXX-KY)

This option also utilizes the top-of-form control assembly (Figure 1).

SCALE, POINTER, AND WINDOW OPTION (LAXX-LN)

This option contains three indicators: Column Scale, Line Indicator, and Column Pointer as shown in Figure 2.

- The *column scale* is a 17.25-in. long strip that is marked off in 132 divisions representing the possible column locations. The column scale adheres to the plastic print window.
- The *line indicator* mounts on the print head and is used to establish two printing locations. The longer top surface indicates the baseline of the characters in a particular line. When setting up a form or rolling back to a previously printed line, this top surface is used to exactly align where the next character will print. The smaller surface on the right side indicates the position where the next character will print. This position is valid only *after* the Last Character Visibility shift. The line indicator is also included in the APL/ASCII Dual Character Set Option (LAXX-PK).
- The *column indicator* is used in conjunction with the column scale. There are red and green indicator lines on the column indicator to indicate the next column to be printed. The green line is used

before the Last Character Visibility shift, the red line *after* the shift.

ACOUSTICAL COUPLER OPTION (LAXX-LM)

There is a single indicator associated with this option. This red indicator is mounted on the right side of the cover and lights when the telephone handset is properly inserted in the muff assembly and a carrier is detected by the coupler circuitry.

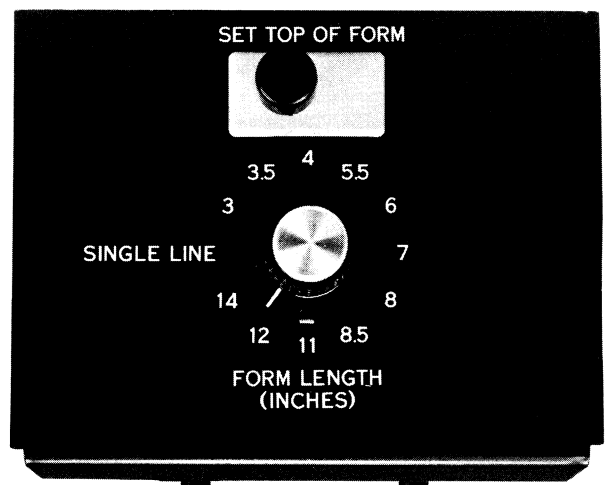

Figure 1 Forms Control Assembly

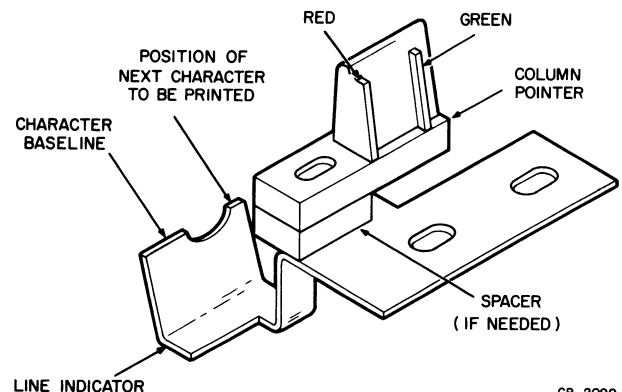

Figure 2 Line Indicator and Column Pointer

SETUP AND OPERATING PROCEDURES FOR LA36 OPTIONS

LA36 options requiring setup or operating instructions in addition to those instructions given for the basic LA36 are presented in the following paragraphs.

NOTE

Throughout the operating and checkout procedures, the Control Key (CTRL) and Escape Key (ESC) are used in conjunction with both alpha and numeric keys to enter commands into the DECwriter. When a procedure requires typing a command, the operator should depress and hold the command key and then depress either the alpha or numeric key.

APL OPTION (LAXX-PK)

An LA36 DECwriter containing this option can print either the standard ASCII characters or the alternate APL characters. The position of the front panel CHAR SET LOCK switch establishes whether control over character set switching is operator-determined (manually) or computer-determined (by programming).

In the up position, the CHAR SET LOCK switch permits the transmitting device to change character sets by sending either a CTRL O (Switch In) or CTRL N (Switch Out) command. CTRL O (code 016_g) selects the standard ASCII character set; CTRL N (code 017_g) selects the alternate APL set.

When the CHAR SET LOCK switch is in the down position, the operator can manually select either available

character set using the ALT CHAR SET switch. In the up position, the ALT CHAR SET switch selects the ASCII character set; in the down position, the alternate APL character set is selected. Illumination of the CHARACTER SET lamps indicates which character set the LA36 will print. The STD lamp illuminates for the ASCII set and the ALT lamp for the APL character set.

Keyboard location of the alternate APL characters is shown in Figure 3. The standard ASCII characters are shown on top of the keys, and the APL symbols are on the front of the key caps.

Figure 4 shows the bit assignments for both character sets.

FORMS CONTROL OPTION (LAXX-KV)

Setup — (The DECwriter is assumed to be deenergized.) Measure the form to determine its length in inches. Then remove the top cover from the LA36 as in paper loading procedures. On the Forms Control panel, set the FORM LENGTH rotary switch to the number that corresponds, in inches, to the length of the form (Table 1). Proceed with the normal loading of the forms. When completed, use the Paper Advance knob to align the top line of the form with the print head. (Normally the top line is 2 or 3 lines below the perforation, but it can be established at any line on the form.) Close the top cover and energize the DECwriter. The form length indicated by the FORM LENGTH switch is automatically entered during the power-up sequence.

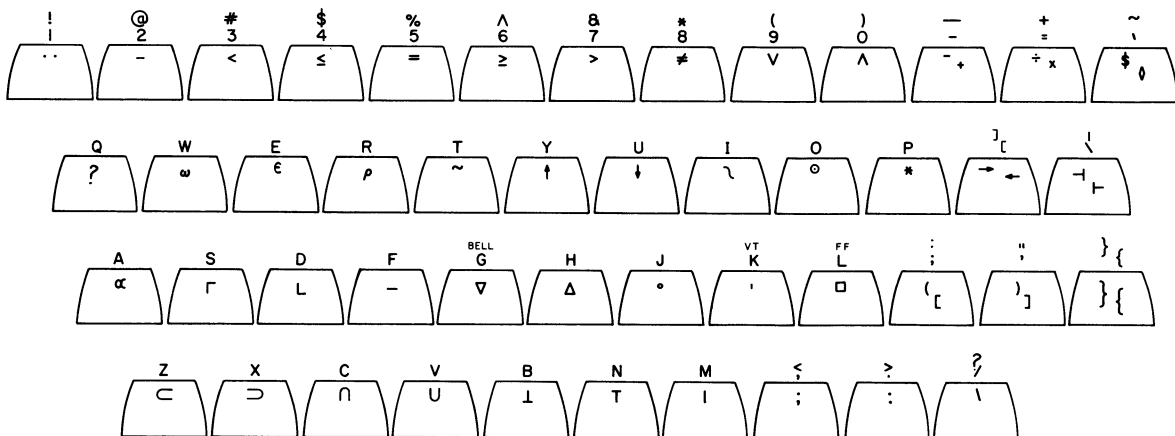

CP-2100

Figure 3 Key Caps Locating APL Characters

Bits					0	0	0	0	1	1	1	1			
					0	0	1	1	0	0	1	1			
b ₇	b ₆	b ₅	b ₄	b ₃	b ₂	b ₁	Column	0	1	2	3	4	5	6	7
Row					0	1	2	3	4	5	6	7			
0	0	0	0	0	0	0	NUL	DLE	SP	0	@	P	\	P	
0	0	0	0	1	1	1	SOH	DC1	!	1	A	Q	a	q	
0	0	0	1	0	1	0	STX	DC2	"	2	B	R	b	r	
0	0	1	1	1	1	1	ETX	DC3	#	3	C	S	c	s	
0	1	0	0	0	0	0	EOT	DC4	\$	4	D	T	d	t	
0	1	0	1	1	1	1	ENQ	NAK	%	5	E	U	e	u	
0	1	1	0	0	0	0	ACK	SYN	&	6	F	V	f	v	
0	1	1	1	1	1	1	BEL	ETB	'	7	G	W	g	w	
1	0	0	0	0	0	0	BS	CAN	(8	H	X	h	x	
1	0	0	1	1	1	1	HT	EM)	9	I	Y	i	y	
1	0	1	0	0	0	0	LF	SUB	*	:	J	Z	j	z	
1	0	1	1	1	1	1	VT	ESC	+	;	K	[k	[
1	1	0	0	0	0	0	FF	FS	,	<	L	\	l	;	
1	1	0	1	1	1	1	CR	GS	-	=	M]	m]	
1	1	1	0	0	0	0	SO	RS	.	>	N	^	n	~	
1	1	1	1	1	1	1	SI	US	/	?	O	_	o	DEL	

a. Standard (ASCII) Character Set

Bits					0	0	0	0	1	1	1	1			
					0	0	1	1	0	0	1	1			
b ₇	b ₆	b ₅	b ₄	b ₃	b ₂	b ₁	Column	0	1	2	3	4	5	6	7
Row					0	1	2	3	4	5	6	7			
0	0	0	0	0	0	0	NUL	DLE	SP	0	~	*	o	F	
0	0	0	0	1	1	1	SOH	DC1	^	1	a	?	A	Q	
0	0	0	1	0	1	0	STX	DC2)	2	l	f	B	R	
0	0	1	1	1	1	1	ETX	DC3	<	3	n	Γ	C	S	
0	1	0	0	0	0	0	EOT	DC4	≤	4	L	~	D	T	
0	1	0	1	1	1	1	ENQ	NAK	=	5	ε	↓	E	U	
0	1	1	0	0	0	0	ACK	SYN	>	6	-	u	F	V	
0	1	1	1	1	1	1	BEL	ETB]	7	∇	ω	G	W	
1	0	0	0	0	0	0	BS	CAN	√	8	Δ	∩	H	X	
1	0	0	1	1	1	1	HT	EM	^	9	l	↑	I	Y	
1	0	1	0	0	0	0	LF	SUB	≠	(o	c	J	Z	
1	0	1	1	1	1	1	VT	ESC	÷	['	←	K	[
1	1	0	0	0	0	0	FF	FS	,	;	□	↑	L	;	
1	1	0	1	1	1	1	CR	GS	+	x	l	→	M]	
1	1	1	0	0	0	0	SO	RS	.	;	τ	≥	N	\$	
1	1	1	1	1	1	1	SI	US	/	\	o	-	O	DEL	

b. Alternate (APL) Character Set

Figure 4 Bit Assignments for ASCII and APL Character Sets

The procedure for setting up the Forms Control Option when the DECwriter is energized is the same except that the SET TOP OF FORM pushbutton has to be pressed after the form length is selected.

Operation – The operator can generate a Form Feed command by typing CTRL L. The program-generated Form Feed (FF) command is 014_g. Upon receipt of a Form Feed command, the paper will advance to the next top-of-form line.

FORM CONTROL PROGRAMMING NOTES

1. To avoid losing incoming characters during a form control operation, fill characters must be added. These nonprinting fill characters (such as NULL or DELETE) effectively slow up the data input rate while the printer mechanism is positioning the form. The best way to determine the required number of these fill characters is to count the number of lines from the last line printed to the bottom of the form and insert this number of fill characters. In character combinations when the character buffer is empty before a carriage return, 15 fill characters can be subtracted from the above number. All fill calculations are made at 300 baud. For 150 baud, halve the values (round off to the next higher number); for 110 baud, use one third (round off to the next higher number).
2. Once a form feed has begun, it cannot be aborted. If a second Form Feed command is issued within 16 lines from the next top of form, the paper will not stop at that next top of form, but will execute the second Form Feed command and skip one full form length. If the second Form Feed command is issued with 17 or more lines remaining to the bottom of the present form, it will be ignored. Likewise, more than two Form Feed commands within one form interval will not be recognized.

FORMS CONTROL, VERTICAL TABULATION, AND HORIZONTAL TABULATION OPTION (LAXX-KY)

Setup – This option requires three setup procedures.

Forms Control Setup – Exactly the same as in the Forms Control Option (LAXX-KV).

Vertical Tabulation Setup – First perform the Forms Control setup and, after establishing the top-of-form position, use the LINE FEED key to move the form to the desired location of the first vertical tab. To store this line count, type ESC 3 on the keyboard or issue 033_g

and 063_g remotely. Advance the form to the next vertical tab and store this location in the same manner. The number of tabs that can be set is limited by the number of printable lines on the form used. For example, an 11-in. deep form could have up to 66 vertical tabs.

Table 1
FORM LENGTH Switch Positioning

Form Length (inches)	FORM LENGTH Switch Setting	Printable Lines Per Form (Maximum)
3	3	18
3.5	3.5	21
4	4	24
5.5	5.5	33
6	6	36
7	7	42
8	8	48
8.5	8.5	51
11	11	66
12	12	72
14	14	84

To clear all vertical tabs, type ESC 4 or issue codes 033_g then 064_g remotely. All tabs are cancelled (cleared) during a power-up sequence.

VERTICAL TABULATION PROGRAMMING NOTES

1. Similar to the form feeding sequence, the vertical tabulation action requires fill characters to slow up the input data while the mechanism is advancing the form. Use the same rule as before to determine the number of fill characters.
2. If a Vertical Tab command is issued and there are no tab locations set, typing CTRL K will initiate a form feed (FF) and advance the paper to the next top-of-form location.
3. Once a vertical tab has begun, it cannot be aborted. If a second Vertical Tab command is issued within 16 lines from the next vertical tab stopping position, the paper will not stop at that next position, but will advance to the second vertical tab location. If a second Vertical Tab command is issued with 17 or more lines remaining in the present advance, it will be

ignored. Likewise, more than two Vertical Tab commands within one tab interval will not be recognized.

Horizontal Tabulation Setup – Before setting horizontal tabs, issue a carriage return (either from the keyboard or remotely by code 015_g). This ensures that the print head starts at the left margin. Issue space characters (by keyboard space bar or by code 040_g) until the print head is positioned at the desired horizontal tab location. To store this location, type ESC 1 or issue codes 033_g then 061_g.

NOTE

Typing ESC 1 moves the print head one character position.

Then space the print head to the next desired tab location and store this location in the same manner. The number of horizontal tabs that can be set is limited by the available number of print columns on the form. For example, a 17-in. wide form can have up to 132 tabs. Striking the TAB key will initiate a horizontal tab move. To clear all horizontal tabs, type ESC 2 or issue codes 033_g then 062_g remotely. All horizontal tabs are cancelled (cleared) during a power-up sequence.

HORIZONTAL TABULATION PROGRAMMING

NOTES

1. To ensure against loss of data while the printer mechanism is executing horizontal tabs, fill characters are used to effectively slow up incoming data. The number required is determined by multiplying the number of spaces between tabs by 0.55 (round off to the next higher number) or by using 12, whichever is greater. The 12 fill characters are needed to compensate for the maximum carriage return time. In instances where the tab does not follow a carriage return, only 0.55 times the number of spaces are needed for fills. All fill calculations are made at 300 baud. For 150 baud, halve the value (round off to the next higher number); for 110 baud, use one third (round off to the next higher number).
2. If a Horizontal Tab command is received and there are no tab locations set, the print head will advance to column 132 and remain there until a carriage return is received.
3. Once a horizontal tab has begun, it cannot be aborted. If a second Horizontal Tab command is issued within 16 spaces from the next horizontal tab stopping position, the head will not stop at that next position, but will advance to the second

horizontal tab location. If a second Horizontal Tab command is issued with 17 or more spaces remaining in the present advance, it will be ignored. Likewise, more than two Horizontal Tab commands within one tab interval will not be recognized.

AUTOMATIC LINE FEED OPTION (LAXX-LA)

The Auto Line Feed action is controlled by the setting of the front panel AUTO LF switch and the presence of jumper W1 on the auto line feed assembly circuit board. Table 2 shows the various conditions that produce the specified number of line feeds when in line mode of operation.

**Table 2
Auto Line Feed Setup**

Position of AUTO LF Switch	Jumper W1 In or Out	Initiating Action	Number of Line Feeds Transmitted or Received
Transmit Mode			
Up	N/A	Type RETURN	0
Down	N/A	Type RETURN	1
Receive Mode			
N/A	In	Receive CR with LF	2
		Receive CR without LF	1
N/A	Out	Receive CR with LF	1
		Receive CR without LF	0

When operated in the receive mode with W1 not cut out, the DECwriter will automatically insert a Line Feed command after each Carriage Return command received. This is a convenience for existing programs that do not normally have a Line Feed after a Carriage Return command. To disable this automatic insertion of the Line Feed command, cut jumper W1 located on the Automatic Line Feed Option circuit board.

AUTOMATIC LINE FEED PROGRAMMING

NOTES

1. If jumper W1 is not cut and the received program already transmits a line feed after each carriage return, a second line feed action will be performed by the printer.

2. With jumper W1 inserted, a nonprinting, non-spacing fill character must be sent after each carriage return. An idle (marking) line time of one character is required after each carriage return to ensure no loss of data during the mechanical action of the printer.

AUTOMATIC ANSWERBACK OPTION (LAXX-KX)

The Auto Answerback Option provides for up to 20 programmable character locations. This stored message is printed out when in local mode and either the front panel HERE IS switch is pressed or an ENQ (005_g) command is received.

The message is stored in twenty 7-bit slide switches located on the Auto Answerback board as shown in Figure 5. The 7-bit ASCII code for the letter "a" is also shown. Slide switch No. 1 corresponds to bit 1 and the ON position corresponds to an asserted (high) logic state.

Any legitimate ASCII character can be included in the answerback message, including commands, alpha, or numeric characters.

NOTES

1. Spaces are counted as characters.
2. Messages shorter than 20 characters can be terminated by making the last character a NUL (0000000). All remaining characters are disregarded. A full 20-character message does not require a NUL at the end.

The Automatic Answerback Option also contains the operational features of the Automatic Line Feed Option (LAXX-LA). The position of the front panel AUTO LF switch determines the insertion of a line feed after a carriage return. The Auto Answerback circuit board contains two factory-installed jumpers (Figure 16) that can be cut out to eliminate certain operations of the auto line feed function. The possible jumper configurations are:

Jumpers		Action	
W1	W3	Add LF to Received CR	Insert LF After Keyboard Typed CR
In	In	Yes	Yes
In	Out	Yes	No
Out	In	No	Yes
Out	Out	No	No

SELECTIVE ADDRESSING OPTION (LAXX-KW)

The Selective Addressing Option has two 7-bit DIP switches mounted on the logic board as shown in Figure 6. One switch establishes the unique address code; the other the group address. These codes are entered by positioning the seven slide switches as shown in the example of Figure 6.

Under the 7-bit code, a practical limit of 123 devices may be interrogated, since the selection command codes (CTRL D, CTRL E, CTRL B, CTRL C, and CTRL F) should not be used as addresses. However, it may be advisable to set the limit to 96 devices, as the 32 ASCII control codes may cause other undesired systems operation. When group selecting, there is no limit to the number of terminals that may be in the group.

When the Selective Address Option is installed in an LA36 and the terminal is connected into a multipoint communications network, there are four classes of master/slave operation. There are three slave states and one master state, as follows:

- Master – Any terminal in the network can be the master, but only one terminal is master at any one time. As master, the terminal can communicate with all the other terminals (designated as slaves) in the network.
- Broadcast Slave – A condition that allows all terminals in the network to receive data transmitted by the master.
- Group Select Slave – When addressed by the master using the group address entered into the Group Select switch on the option board, a particular group of terminals can receive data sent by the master. Terminals not having this particular group address do not receive data even though they are within the same communications network.
- Unique Select Slave – Each terminal can have a unique address which is different from its group address code. When addressed using this unique code by a master, it is possible to establish 2-way communication between these two terminals and no other terminals in the network. Also, this uniquely selected terminal can be inhibited from transmitting by the master.

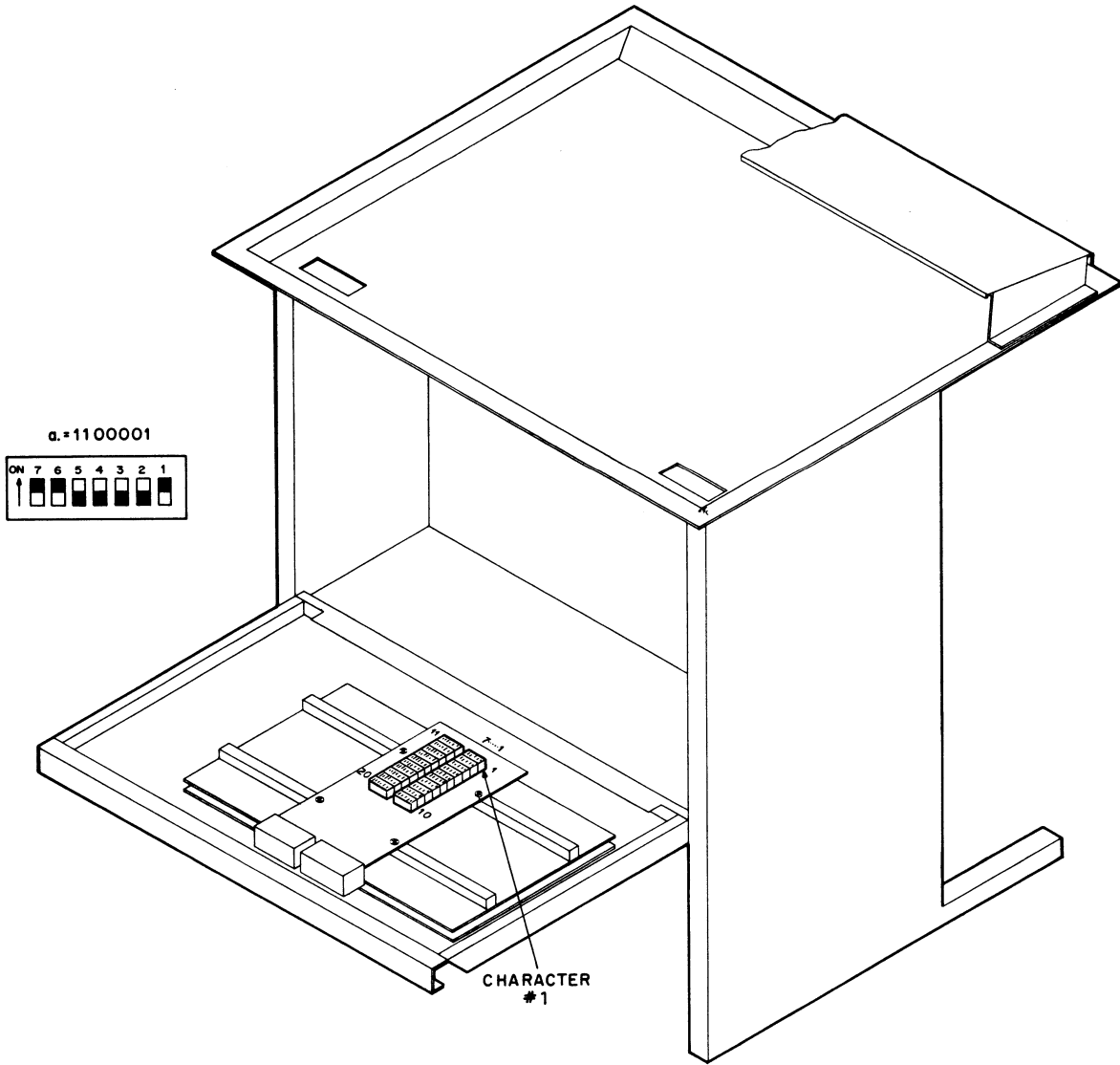

CP-2101

Figure 5 Location of 20 Answerback Message Characters

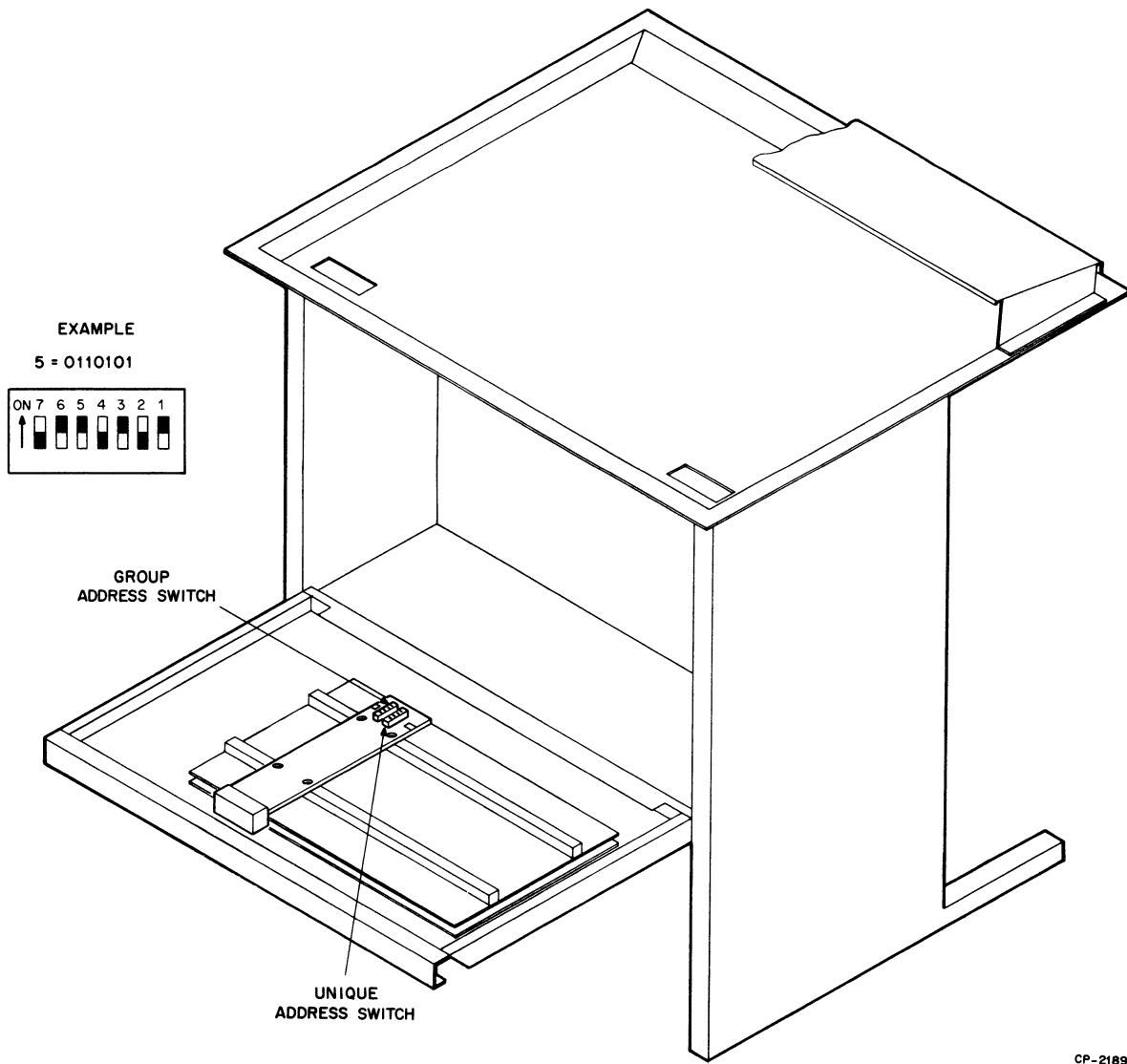

Figure 6 Location of Address Setting Switches

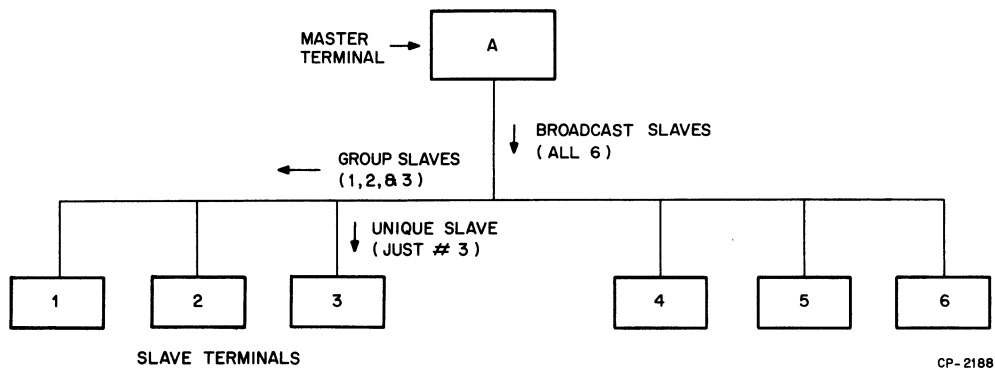

Figure 7 Typical Selective Addressing Communications Network

Figure 7 depicts a communications network of seven terminals. It is assumed that terminal A is the master and the other six are slaves, each with a unique address; terminals 1, 2, and 3 have the same group address while 4, 5, and 6 have a different group address. When the master (A) transmits in broadcast, all terminals print the transmission. When the master addresses the three having the same group address, only these three receive the transmitted data. The master can also use the unique address of one of the six to establish communication while the other five disregard all transmission between these two. In addition, the master can address multiple unique addresses to form other groups (i.e., terminals 1, 3, and 6 can be grouped to receive the same data if the master sequentially addresses these terminals).

Slave terminals operate in either the address mode or data mode. In the address mode, terminals respond to character combinations that make up their broadcast, unique, or group addresses. In the data mode, they do not acknowledge their addresses, even though the address is present on the communications line. The master terminal establishes whether the slave terminals are in one mode or the other.

The following six commands are generated at the master terminal and control the operation of the communications network.

1. CTRL SPACE (NUL) – Used after a terminal has become master to reset all slave terminals to their address mode. This action occurs before the master sends addresses down the line.

2. CTRL G (BELL) – Used to select all terminals to receive simultaneously (broadcast mode). Until a CTRL B has been received, the BELL code does not cause the bell on the printer to sound.
3. CTRL B (STX) – Used to “lock” all terminals in their selected or unselected mode and to prevent an unintentional selection during data transmission. No terminal begins to print until CTRL B is received. The terminal uniquely addressed before the CTRL B command has its keyboard enabled for transmission, thus allowing a 2-way communication.
4. CTRL E (ENQ) – Only used with uniquely selected slave terminals (has no effect on broadcast and group selected slaves). When a uniquely selected slave terminal has an Auto Answerback Option (LAXX-KX) installed and receives a CTRL E, the stored answerback message is sent back to the master terminal. This allows verification that the correct slave terminal is being addressed. The answerback message is transmitted after the EIA interface CLEAR TO SEND signal goes high.

CTRL E can also be used to disable the transmitting capability of a uniquely selected slave. Normally a uniquely selected slave can transmit back to the master but it can be disabled by the following commands from the master: unique address, CTRL E, then any character or command except CTRL B.

NOTE

On a multipoint network using modems, only one slave can be allowed to transmit. Therefore, when uniquely selecting a slave terminal, a CTRL E should follow each address, leaving only the last terminal selected able to transmit.

In the case of multiple selections where it is desirable to have only the master transmitting, the last terminal selected should be followed by a nonvalid dummy address (i.e., unique address; CTRL E; dummy address; CTRL B). This leaves all slaves transmit-disabled.

5. CTRL C (ETX) – Upon receiving CTRL C, all slave terminals switch from the data mode to the address mode and terminal selection can take place. This allows a master to select additional devices without having to surrender the lines or having to readdress previously selected stations. To continue addressing additional terminals, the normal selection rules apply, with the sequence terminating with CTRL B to lock all devices into either the selected or unselected modes.
6. CTRL D (EOT) – Used to reset all terminals on the line so that none are selected. When CTRL D is typed at the end of the master's transmission, the control over the network is removed from the master and any terminal can become master. It is also used to select a terminal as the master anytime the SELECT AVAIL light is illuminated.

A terminal becomes master and places the slaves in address mode by performing the following sequence:

Power-up.
Master and all slaves in full duplex mode.
Front panel SELECT AVAIL light on.
Type CTRL D.
Wait for DEVICE SELECT light to illuminate.
Type CTRL SPACE.

After becoming master, this terminal can establish the type of slaves in the network as follows:

Broadcast

Type CTRL G.
Type CTRL B.
Send message – All terminals receive but cannot transmit.
Type CTRL D at the end of a message.

Group

Type group address.
Type CTRL B.
Send message – All terminals in group receive but cannot transmit.
Type CTRL D at the end of a message.

Unique Select (2-way)

Type Unique Address.
Type CTRL E.
Type CTRL B.
Send message – Both master and slave can transmit and receive.
Type CTRL D at the end of a message.

Unique Select (1-way)

Type unique address.
Type CTRL E.
Type any character other than a valid address.
Type CTRL B.
Send message – Slave can receive but not transmit.
Type CTRL D at the end of a message.

Select (add-on)

To add other terminals to terminals already selected without having to readdress all terminals, perform the following:

Type CTRL C.
Type new address or addresses.
Type CTRL B.
Send message.
Type CTRL D at the end of a message.

SELECTIVE ADDRESSING PROGRAMMING NOTES

1. Anytime more than one terminal is uniquely selected, a CTRL E command should follow each unique address. The last address in the sequence does not have to be followed by a CTRL E if this terminal is to remain transmit-enabled. Refer to the description of the CTRL E command.
2. Ensure that a CTRL D command follows the end of all transmitted messages. This relinquishes control of the network by the master and allows other terminals to become master.
3. In applications where the EIA signal CLEAR to SEND is always high, the command CTRL SPACE is not required.

ACOUSTICAL COUPLER OPTION (LAXX-LM)

Setup – The following conditions must be met before using the acoustical coupler: printer power on, on-line, baud rate matched to sending system. Call the number of the sending system and listen for the carrier sound (loud whistle). After receipt of carrier, place the handset into the acoustical coupler muff assembly with the phone cord end of the handset inserted into the muff with the "dot" and/or word "CORD" next to it. Within 5 seconds, the carrier light illuminates. Normal system operation may now commence.

NOTE

Before removing the telephone handset from the muff assembly, place the DECwriter in the local mode. This action prevents the disconnect noise from causing printing of random characters.

INSTALLATION AND CHECKOUT OF LA36 OPTION KITS

INTRODUCTION

Figure 8 contains three basic cabling diagrams for the LA36. These diagrams depict the cabling configurations between the M7728 logic board and the Expander Mounting Option (LAXX-LB) for the various option kits available. Before installing any option, it is recommended that these diagrams be consulted to ensure proper cabling.

EXPANDER OPTION MOUNTING KIT (LAXX-LB)

The Expander Option Mounting Kit contains the following:

Quantity	Item	Part Number
1	Option Distribution Board Assembly	
1	Right-Hand Side Rail Assembly	See D-UA-LAXX-LB-0
1	Left-Hand Side Rail Assembly	
4	Grommets	9007017-00
2	Interconnecting Cables	C-IA-BC08S-1B
1	Keyboard Cable	C-IA-7008612-4A
1	+5 Volt Power Cable	C-IA-7010001-8

A nut driver, Phillips, and straight blade screwdrivers are required to install the Expander Option Mounting Kit. Use Figures 8, 9, and 10 and the following procedure as installation guides.

1. Unplug the ac power cord. Remove the paper, top cover, and plastic housing from the unit.
2. Unhook all cables from the logic board.
3. Remove the six screws and washers that secure the logic board to the cabinet door and then remove the logic board. The keyboard cable clamp should also be removed from below the logic board.
4. Place the right and left side brackets (1 in Figure 10) over the screw studs as shown. The hinge tabs of the side brackets (2) should be pointed inward toward each other and toward the interior of the cabinet.
5. Place a grommet (3) over each stud that sticks up through the brackets.
6. Carefully replace the logic board on top of the grommets and secure with the six screws and associated washers previously removed.
7. On the option distribution board assembly (Figure 10), remove screw (4) and loosen screw (5) on each hinge bracket.
8. Squeeze each hinge bracket toward the middle until the hinge tabs (2) of the side brackets can be inserted into the pivot holes as shown.
9. Insert the two screws (4) and tighten these screws and screws (5).
10. Lock both ¼ turn fasteners (6) to secure the option distribution board assembly to the side rails.
11. Connect the interface cables as shown in Figure 8, depending upon the options being installed.
12. Reconnect the +5V supply cable (black and red wires) to the logic board. Connect one end of a similar cable (supplied with this option) to the +5 and GND terminals of the power board and the other cable end to the Faston terminals (7 in Figure 10) on the option distribution board assembly. Route the cable with existing cables to the power board.
13. To connect the front panel control cable, the bezel must be removed.
14. Remove the four screws, lock washers, flat washers (1 in Figure 9), and spacers (2 in Figure 9) that secure the keyboard bezel to the cabinet base.

CAUTION

The ribbon cables between the logic board and the expander board must be installed so that one cable end (either end) has the ribbed side of the cable facing up and the other end has the smooth side up. Ensure that A connects to A at each cable end. Failure to observe this polarity may cause a logic board failure.

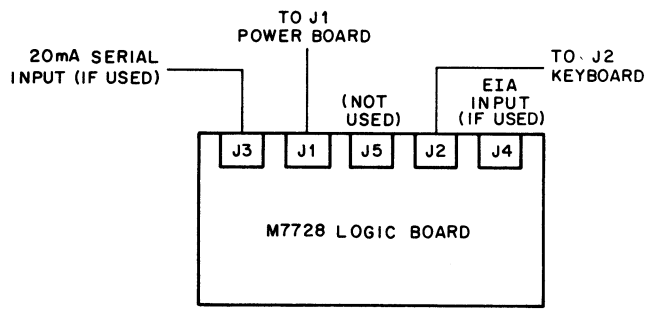

A. NO OPTIONS INSTALLED

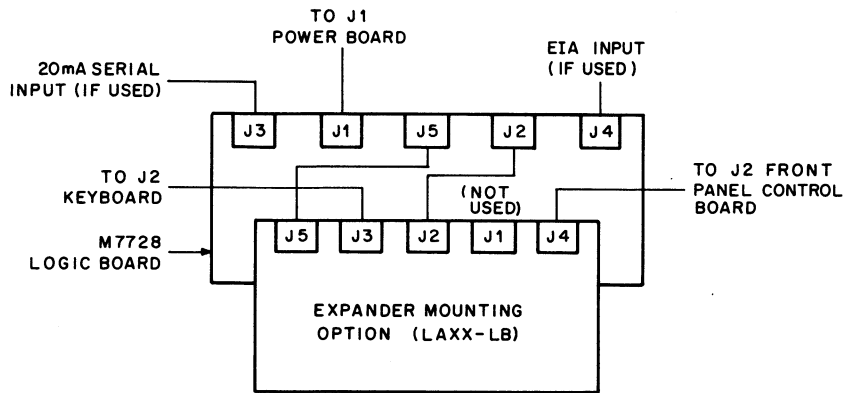

B. ANY OPTION
AND AUTO LINE FEED OR AUTO ANSWER BACK OPTIONS
NOT INSTALLED

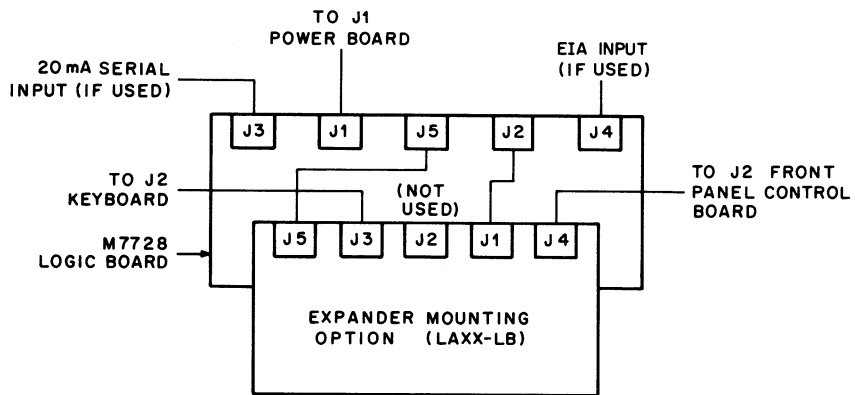

C. ANY OPTION AND
AUTO LINE FEED OR AUTO ANSWERBACK OPTIONS INSTALLED

CP-2102

Figure 8 Cabling Configurations for Various LA36 Options

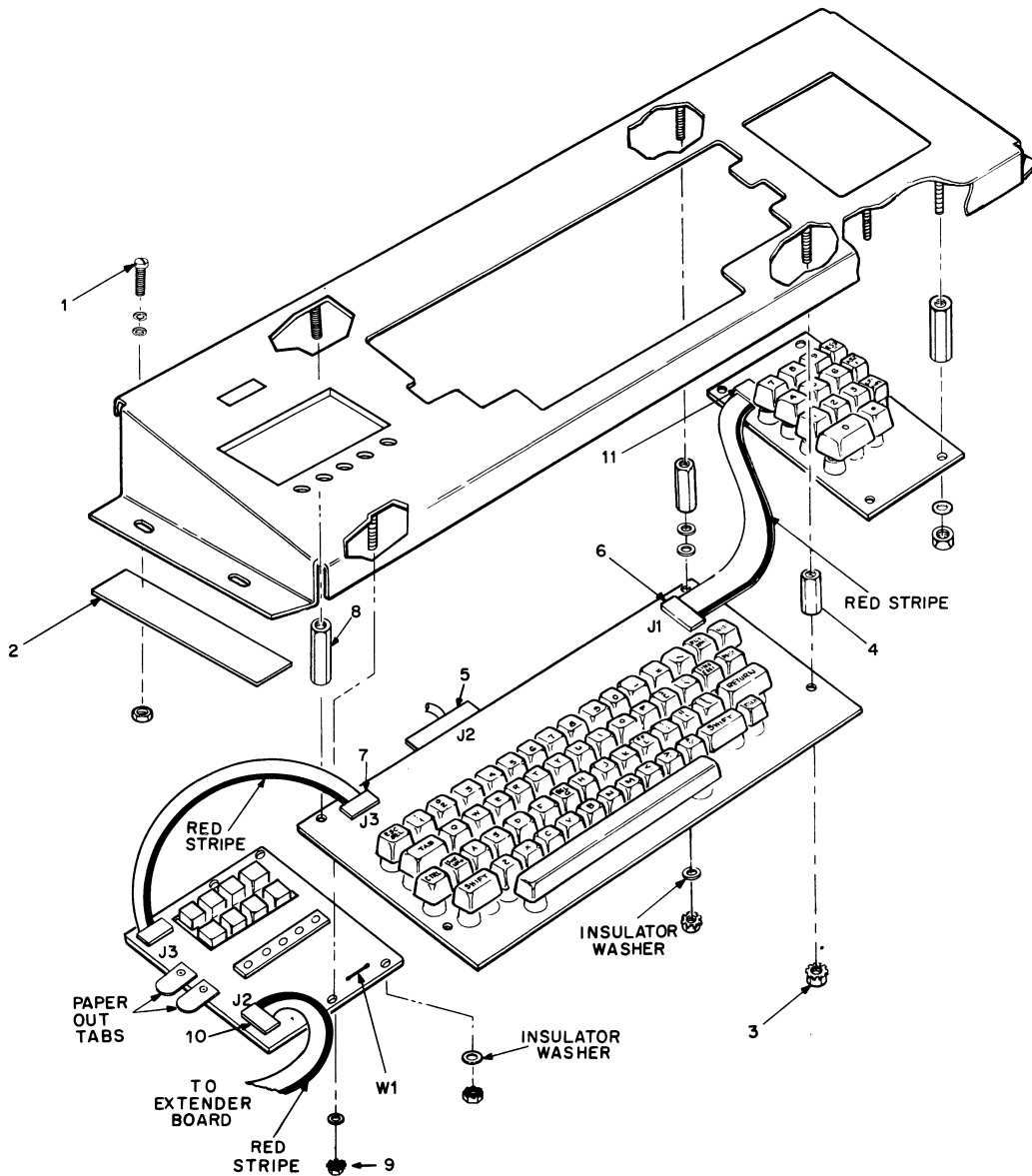

CP-2103

Figure 9 Keyboard and Bezel Assembly – Cabling and Hardware

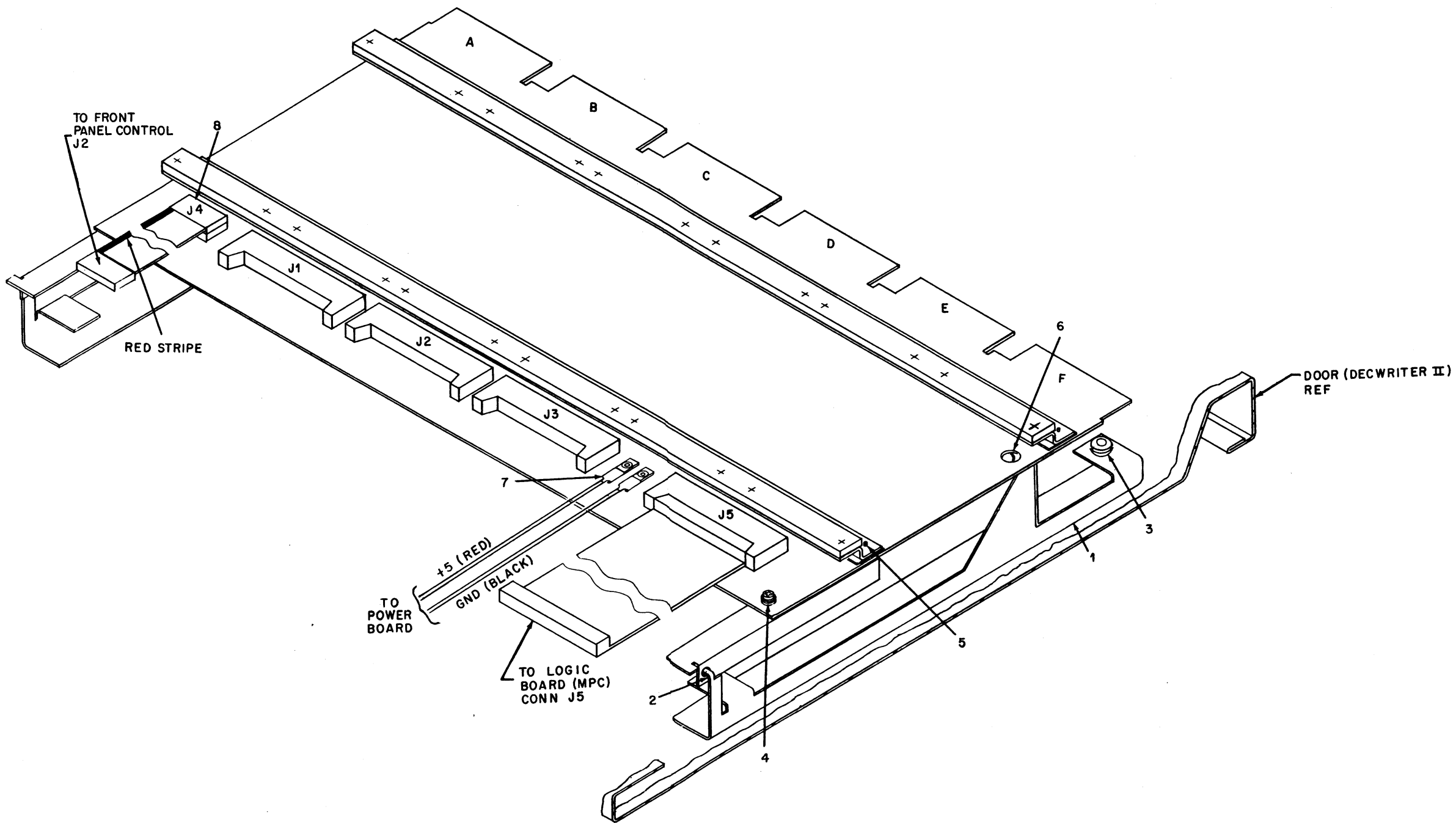

CP-2104

Figure 10 Installation of Expander Mounting Kit (LAXX-LB)

15. Turn the bezel upside down on a piece of foam or bubble plastic and remove the four Kep nuts (9 Figure 9) that secure the front panel control assembly to the bezel. Leave the four hex standoffs in place.

NOTE

In some instances it may be necessary to remove the keyboard assembly before the front panel control assembly can be removed.

16. Connect one end of the front panel control cable to J2 as shown in 10, Figure 9. Ensure that the red stripe on the ribbon cable is as indicated.
17. Feed the cable across the cabinet and down through the access hole and to J4 (8), Figure 9 on the option distribution board assembly. Ensure that the red stripe on the cable is positioned as shown in Figure 10.

NOTE

If either the APL Option (LAXX-PK), Paper Out Option (LAXX-KZ), or the 14-Key Numeric Keypad Option (LAXX-KE) is also being installed, the applicable installation procedure should be consulted before the keyboard bezel is secured back onto the cabinet base.

18. Replace the front panel control assembly on the standoffs and secure with four Kep nuts. Provide adequate cable clearances around all standoffs.

CAUTION

Ensure that the insulating washers are inserted between the Kep nuts and the etch side of the circuit boards as shown in Figure 9. Failure to install washers at required points may cause circuit damage.

19. Replace the keyboard bezel on the cabinet base and secure with the four screws, lock washers, flat washers, and spacers.

CAUTION

The keyboard bezel should be positioned as far forward as possible to eliminate interference between the keyboard cable and print head assembly.

Ensure that the spacers are placed under the keyboard bezel. Failure to do so may result in damage to the print head because of interference with the keyboard connector.

20. Replace the plastic housing and cover.

Test After Installation – Load paper and energize the DECwriter. In local mode, typing will produce printed characters.

APL OPTION KIT (LAXX-PK)

The APL Option Kit contains the following:

Quantity	Item	Part Number
1	APL/ASCII Dual Character Set Board	D-CS-M7732-0-1
1	Edge Connector	B-UA-H851-0-0
1	APL ROM	23086A6
1	APL ROM	23087A6
4	Phillips Pan Head Screws (#34-40 X 0.38 in.)	9006011-1
4	Flat Washers (#4)	9006655
4	Lock Washers (#4)	9006688
1	Line Indicator	C-MD-7414953-0-0
1	APL Keyboard	D-AD-7011055-0-0

A Phillips screwdriver and a 11/32-in. nut driver are required tools for installation. Use Figures 9 and 11 plus the following procedure as installation guides.

NOTE

Unplug the DECwriter and remove paper.

1. If not already installed, install the Expander Option Mounting Kit (LAXX-LB).
2. Refer to Figure 8 for the correct interface cabling required to integrate the APL Option into the existing options.
3. Using the supplied hardware (1 in Figure 11) (four #4-40 X 0.38-in. screws and #4 washers), secure the APL board in location F on the expander board (Figure 11).
4. Install the H851 edge connector (2). (Edge connector and board are keyed for proper fit.)
5. Insert the two APL ROMs: No. 23087A6 in socket (3) and No. 23086A6 in (4). Refer to Figure 11 for Pin No. 1 locations.
6. Remove the cover and top plastic housing from the DECwriter.

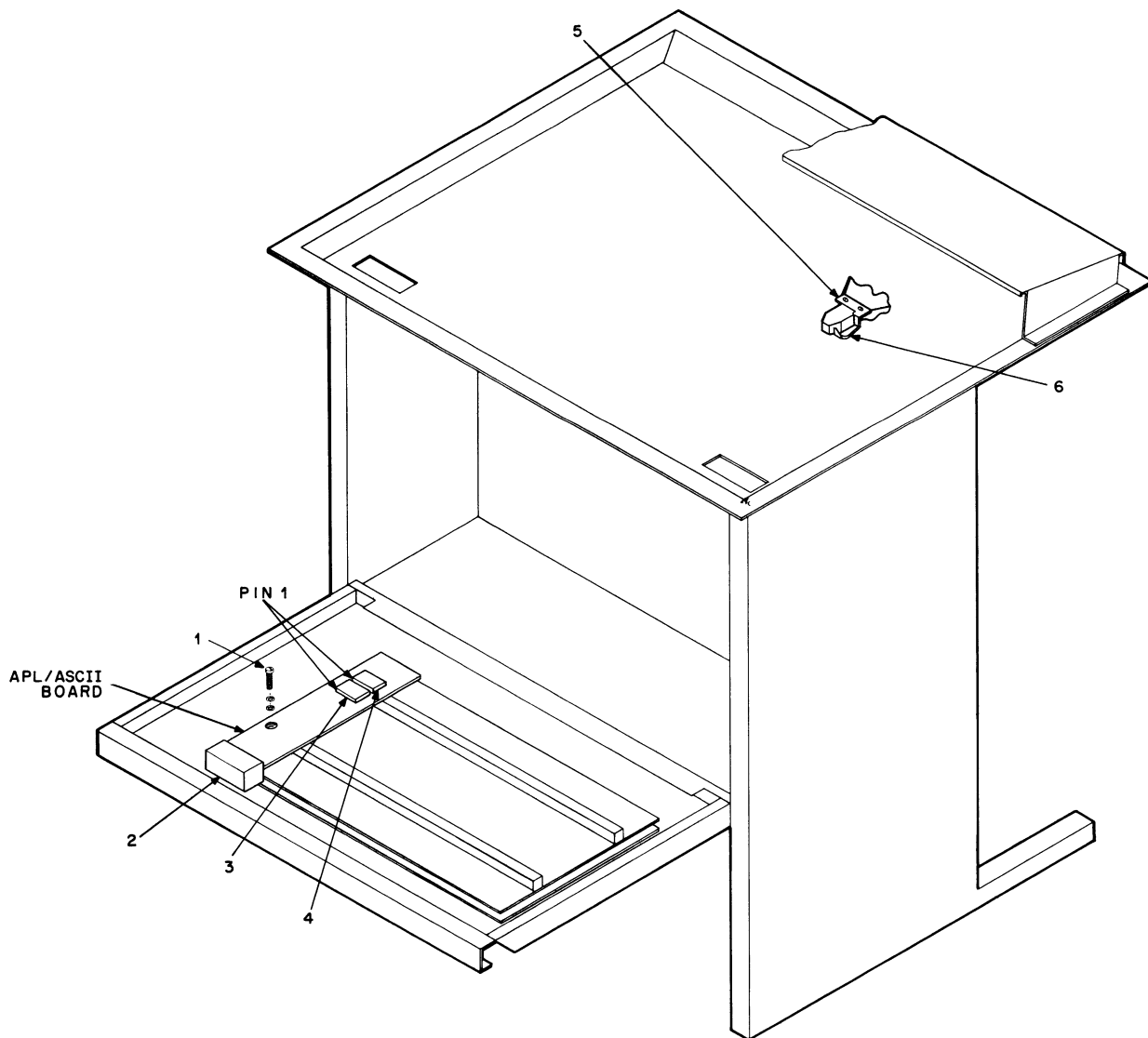

CP - 2105

Figure 11 Installation of the APL/ASCII Dual Character Set Board

7. Remove the two front screws (5) and associated washers from the print head, install the line indicator (6) as shown, and reassemble the removed hardware.

NOTE

Unless otherwise specified, all following references are made to Figure 9.

8. Remove the four screws, lock washers, flat washers (1) and spacers (2) that secure the keyboard bezel to the cabinet base.
9. Turn the keyboard bezel upside down on a piece of foam or bubble plastic and remove the four Kep nuts (3) that secure the keyboard to the bezel. Leave the four hex standoffs (4) in place.
10. Carefully lift the keyboard off the weld studs, disconnect the Berg connector (5) from J2 on the keyboard, and set the keyboard aside. If the equipment also uses a numeric keypad, disconnect the cable connector from J1 (6). On the control panel board, disconnect the cable from J3 (7).
11. Remove the four Kep nuts (9) that secure the front panel control assembly to the bezel. Leave the four hex standoffs in place.
12. Cut jumper W1. See Figure 9 for location of W1 on the front panel control assembly.
13. Replace the front panel control assembly on the standoff and secure with the Kep nuts.

CAUTION

Ensure that the insulating washers are inserted between Kep nuts and the etch side of the circuit board. Failure to install washers at required points may cause circuit damage.

14. Reconnect the Berg connector to J2 on the new keyboard. If required, reconnect the cables at J1 and J3. Ensure that the red stripe on each cable is positioned as shown in Figure 9.

CAUTION

The keyboard cable must be routed to the inside of standoff (3) and between the bezel and the component side of the keyboard. This prevents possible interference between the cable and print head assembly.

NOTE

In some instances, it may be necessary to remove the control panel board before the keyboard can be removed.

15. Place the new keyboard on the weld studs and secure it with the four Kep nuts. Provide adequate cable clearances around standoffs.

CAUTION

If required, ensure that the insulating washers are inserted between the Kep nuts and the etch side of the circuit boards as shown in Figure 9. Failure to insert washers at the required points may cause circuit damage.

16. Replace the keyboard bezel on the cabinet base and secure with the four screws, lock washers, flat washers, and spacers.

CAUTION

The keyboard bezel should be positioned as far forward toward the operator as possible to eliminate interference between the keyboard cable and print head assembly.

Ensure that the spacers are placed under the keyboard bezel. Failure to do so may result in damage to the print head because of interference with the keyboard connector.

17. Replace and secure the plastic housing and replace the cover.

Test After Installation — Install paper and apply power. In the local mode with both ALT CHAR SET and CHAR SET LOCK switches down, the DECwriter will print APL characters as typed.

FORMS CONTROL OPTION KIT (LAXX-KV)

The Forms Control Option Kit contains the following:

Quantity	Item	Part Number
1	Top-of-Form Control Assembly Board	D-AD-7011503-0-0
1	Top-of-Form Module Board	D-CS-M7735-0-1
1	Top-of-Form Cable	D-IA-7011516-0-0
4	Phillips Pan Head Screws (#4-40 X 3/8 in.)	9006011-1
4	Phillips Pan Head Screws (#6-32 X 3/8 in.)	9006022-1
1	Edge Connector	B-UA-H851-0-0
4	Lock Washers (#4)	9006688
6	Lock Washers (#6)	9007801
4	Flat Washers (#4)	9006655
4	Flat Washers (#6)	9006653

A Phillips screwdriver is the only tool required for installation. Use Figure 12 and the following procedure as installation guides.

1. Unplug the ac power cord and open the top cover.
2. If not already installed, install the Expander Option Mounting Kit (LAXX-LB).
3. Refer to Figure 8 for the correct interface cabling required to integrate the Forms Option into the existing options.
4. Unscrew the attaching hardware of the bell speaker. Save the two #6 flat washers and two #6-32 X 3/8-in. screws but discard the Kep nuts.
5. Remove and save the bracket hardware (2) (#8-32 X 3/8-in. screw, #8 lock washer, #8 flat washer).
6. Attach the speaker to the inside of the top-of-form control assembly (1). Use four #6-32 X 3/8-in. screws, #6 flat and lock washers and secure from the inside as in (4).
7. The top-of-form cable has two distinct ends, differing by the length of the wire leads and type of push-on connectors. The cable end with the

longer leads and smaller connectors connects to the top-of-form control assembly and the other end to the top-of-form control module board. Connect the two push-on leads to the terminals on the SET TOP OF FORM switch (3) and plug in the 8-pin connector as shown.

8. Install the top-of-form control assembly using the previously removed #8-32 X 3/8-in. screw and #8 washers as shown in (2). Then secure the two #6-32 X 3/8-in. screws and #6 washers as shown in (5). Screw in from the outside of the bracket.
9. Feed the cable under the printer mechanism then down through the access hole and, using the existing cable clamps, conform the cable as shown.
10. Position the top-of-form control module board (in location "B") on the Expander Option Mounting Kit. Secure with four #4-40 X 3/8-in. screws and #4 washers as in (8).
11. Install the H851 edge connector (7) (edge connector and board are keyed for proper fit) and the 8-pin connector (6) and two push-on connectors as shown.
12. Replace the top cover.

Test After Installation – Perform the following procedure:

1. Energize the DECwriter, load paper, and set the FORM LENGTH switch to correspond to the length of the form in inches. Press and release the SET TOP OF FORM pushbutton.
2. Type any character on the keyboard, then type CTRL L. The paper should feed and stop at a distance that is equal in inches to the switch setting. Repeat this procedure for two other switch settings, one longer, the other shorter than this setting. Press the SET TOP OF FORM pushbutton after changing the setting.
3. Set the FORM LENGTH switch to 3 and press the SET TOP OF FORM pushbutton. Press the LINE FEED key 17 times, then type CTRL L. The paper should increment only one line.

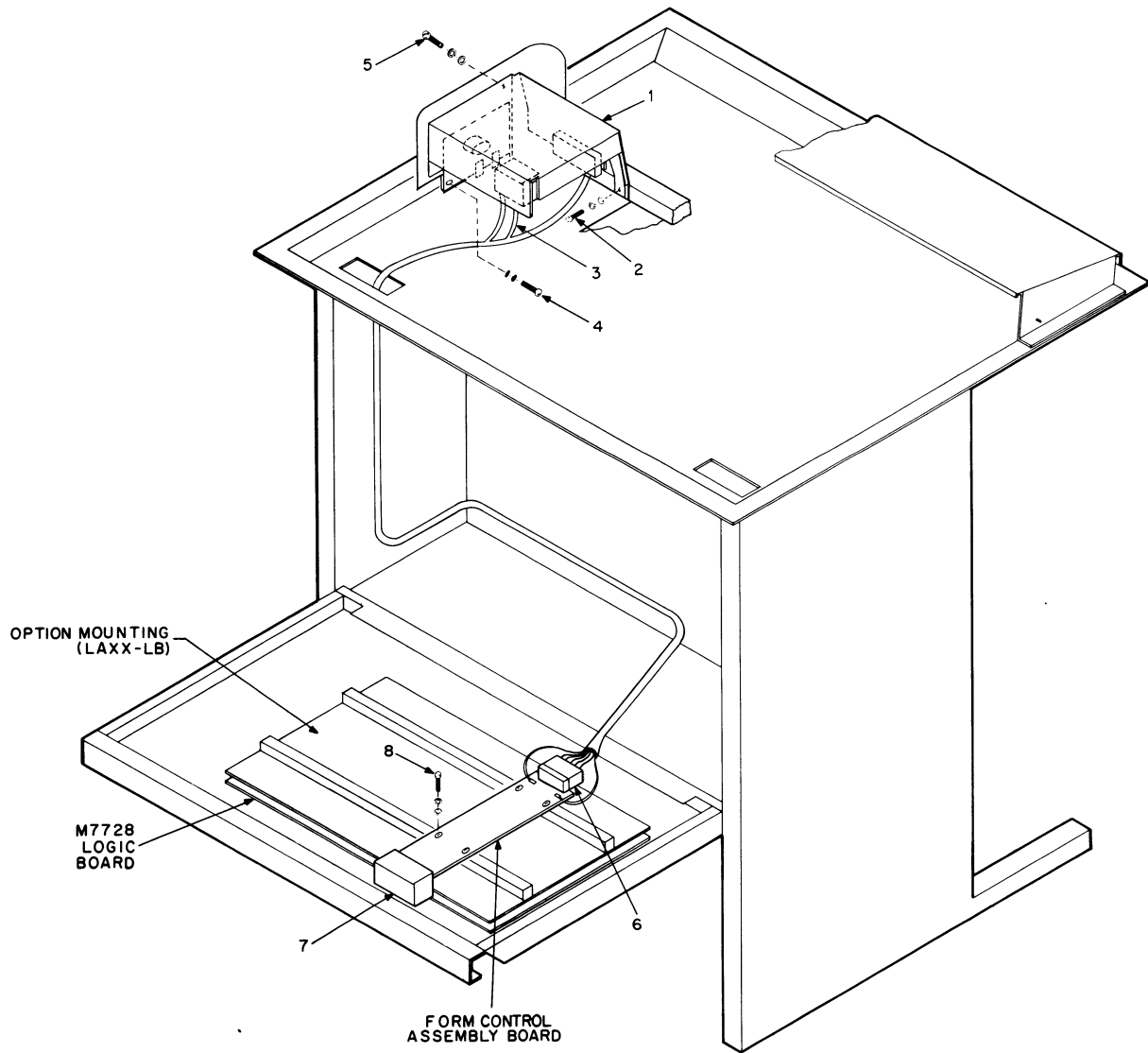

CP-2106

Figure 12 Installation of Forms Control Option Kit (LAXX-KV)

**FORMS CONTROL, VERTICAL TABULATION,
AND HORIZONTAL TABULATION,
OPTION KIT (LAXX-KY)**

The Forms Control, Vertical Tabulation, and Horizontal Tabulation Option Kit contains the Forms Control Option Kit (LAXX-KV) and the following:

Quantity	Item	Part Number
1	Top-of-Form Control Assembly	D-AD-7011503-0-0
1	HT-VT-TOF Module Board	D-CS-M7736-0-1
1	Top of Form Cable	D-IA-7011516-0-0
2	Phillips Pan Head Screws (#4-40 X 3/8 in.)	9006011-1
4	Phillips Pan Head Screws (#6-32 X 3/8 in.)	9006022-1
1	Edge Connector	B-UA-H851-0-0
2	Lock Washers (#4)	9006688
6	Lock Washers (#6)	9007801
2	Flat Washers (#4)	9006655
4	Flat Washers (#6)	9006653

A Phillips screwdriver is the only tool required for installation. Use Figure 13 and the following procedure as installation guides.

1. Unplug the ac power cord and remove the top cover.
2. If not already installed, install the Expander Option Mounting Kit (LAXX-LB).
3. Refer to Figure 8 for the correct interface cabling required to integrate the Forms Control Option into the existing options.
4. Unscrew the attaching hardware of the bell speaker. Save the two #6 flat washers and two #6-32 X 3/8-in. screws but discard the Kep nuts.
5. Remove and save the bracket hardware (2) (#8-32 X 3/8-in. screw, #8 lock and flat washers).

6. Attach the speaker to the inside of the top-of-form control assembly (1). Use four #6-32 X 3/8-in. screws, #6 flat and lock washers and secure from the inside as in (4).
7. The top-of-form cable has two distinct ends, differing by the length of the wire leads and the size of the push-on connectors. The cable end with the longer leads and smaller connectors connects to the top-of-form control assembly and the other end to the HT-VT-TOF module board. Connect the two push-on leads to the terminals on the bottom of the SET TOP OF FORM pushbutton (3) and plug in the 8-pin connector as shown.
8. Install the top-of-form control assembly using the previously removed #8-32 X 3/8-in. screw and #8 washers as shown in (2). Then secure with two #6-32 X 3/8-in. screws and #6 washers as shown in (5). Screw in from the outside of the bracket.
9. Feed the cable down through the access hole and, using the existing cable clamps, conform the cable as shown.
10. Position the HT-VT-TOF module board (in locations A and B) on the Expander Option Mounting Kit. Secure with two #4-40 X 3/8-in. screws and #4 washers as in (8).
11. Install the H851 edge connector (7) in location A (edge connector and board are keyed for proper fit) and the 8-pin connector (6) and two push-on connectors as shown.

NOTE

Only one H851 edge connector is needed. Do not install two connectors.

12. Replace top cover.

Test After Installation — Perform the following procedure:

1. Load paper, energize the DECwriter, and set the FORM LENGTH switch to correspond to the length of the form in inches. Press and release the SET TOP OF FORM pushbutton.
2. Type any character on the keyboard, then type CTRL L. The paper should feed and stop at a distance that is equal in inches to the switch

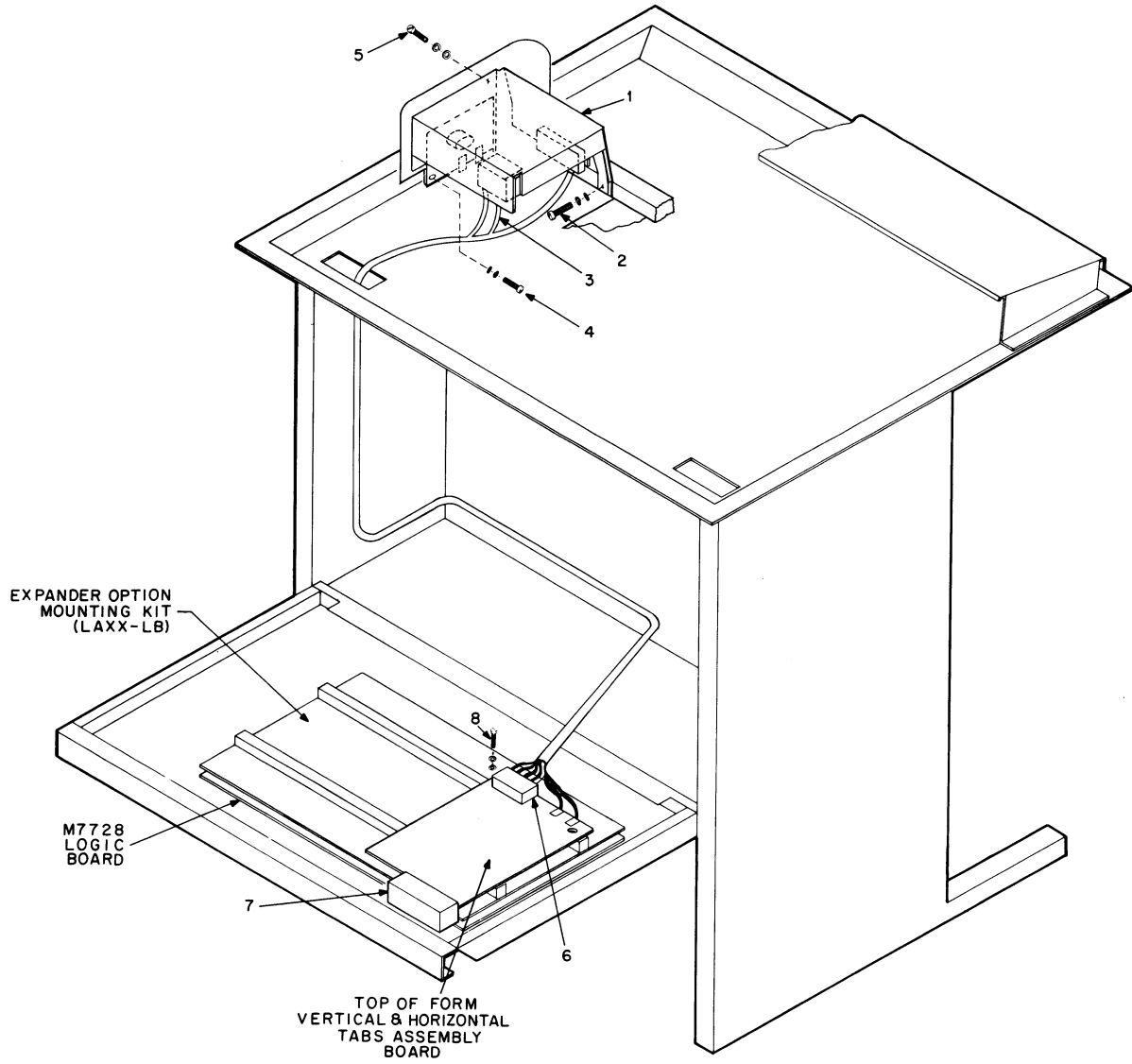

CP-2107

Figure 13 Installation of Forms Control, Vertical Tabulation, and Horizontal Tabulation Option Kit (LAXX-KY)

setting. Repeat this procedure for two other switch settings, one longer, the other shorter than this setting. Press the SET TOP OF FORM pushbutton after changing the setting.

3. Set the FORM LENGTH switch to 3, and press the SET TOP OF FORM pushbutton. Press the LINE FEED key 17 times, then type CTRL L. The paper should increment only one line.
4. After ensuring correct operation of the Forms Control function, set the TOF for 11-in. form paper. (Set switch at 11; press pushbutton.)
5. Type an "A."
6. Type CTRL K; the DECwriter will line feed 11 in. Type a "B."
7. Press the LINE FEED key 10 times, type ESC 3, then type a "C."
8. Type CTRL L. Type a "D." Manually turn the paper back until the print head aligns at the line where "B" was printed.
9. Type CTRL K, then type an "E" (will print next to previously printed "C").
10. Type CTRL K, then type an "F" (will print next to previously printed "D").
11. Type ESC 4, then manually turn the paper back to the line with "B" on it.
12. Type CTRL K; the print head will align on the line containing "D" and "F."
13. Type LINE FEED, RETURN, and TAB. The print head will move to the right margin (column 132).
14. Type RETURN, then press the space bar eight times.
15. Type ESC 1, then type "A."
16. Space eight times; type ESC 1; type "B."
17. Space eight times; type ESC 1; type "C."
18. Type RETURN; type LINE FEED.
19. Type TAB; type "D."

20. Type TAB; type "E."
- 21.. Type TAB; type "F."
22. Type TAB; the head will move to column 132. The printed characters will be in two lines with the top line one character space to the right of the second line.
23. Type RETURN, type TAB twice, then press BACKSPACE ten times.
24. Type TAB; type "G."
25. Type TAB; type "H." The characters "G" and "H" will overprint on the previously printed "E" and "F."
26. Type ESC 2, RETURN, and then TAB. The print head will move to column 132. The test is completed.

AUTOMATIC LINE FEED OPTION KIT (LAXX-LA)

The Auto Line Feed Option Kit contains the following:

Quantity	Item	Part Number
1	Auto Line Feed Board	D-CS-M7738-0-1
2	Edge Connector	B-UA-H851-0-0
3	Phillips Pan Head Screws (#4-40 X 0.38 in.)	9006011-1
3	Lock Washers (#4)	9006688
3	Flat Washers (#4)	9006655

A Phillips screwdriver is the only tool required for installation. Use Figure 14 and the following procedure as installation guides.

1. Unplug the ac power cord.
2. If not already installed, install the Expander Option Mounting Kit (LAXX-LB).
3. Refer to Figure 8 for the correct interface cabling required to integrate the Auto Line Feed Option into the existing options.
4. Using the supplied hardware (1) (three #4-40 X 0.38-in. screws and #4 washers), secure the Auto Line Feed board in locations C and D on the expander board. As shown, one of the mounting holes should not be secured.

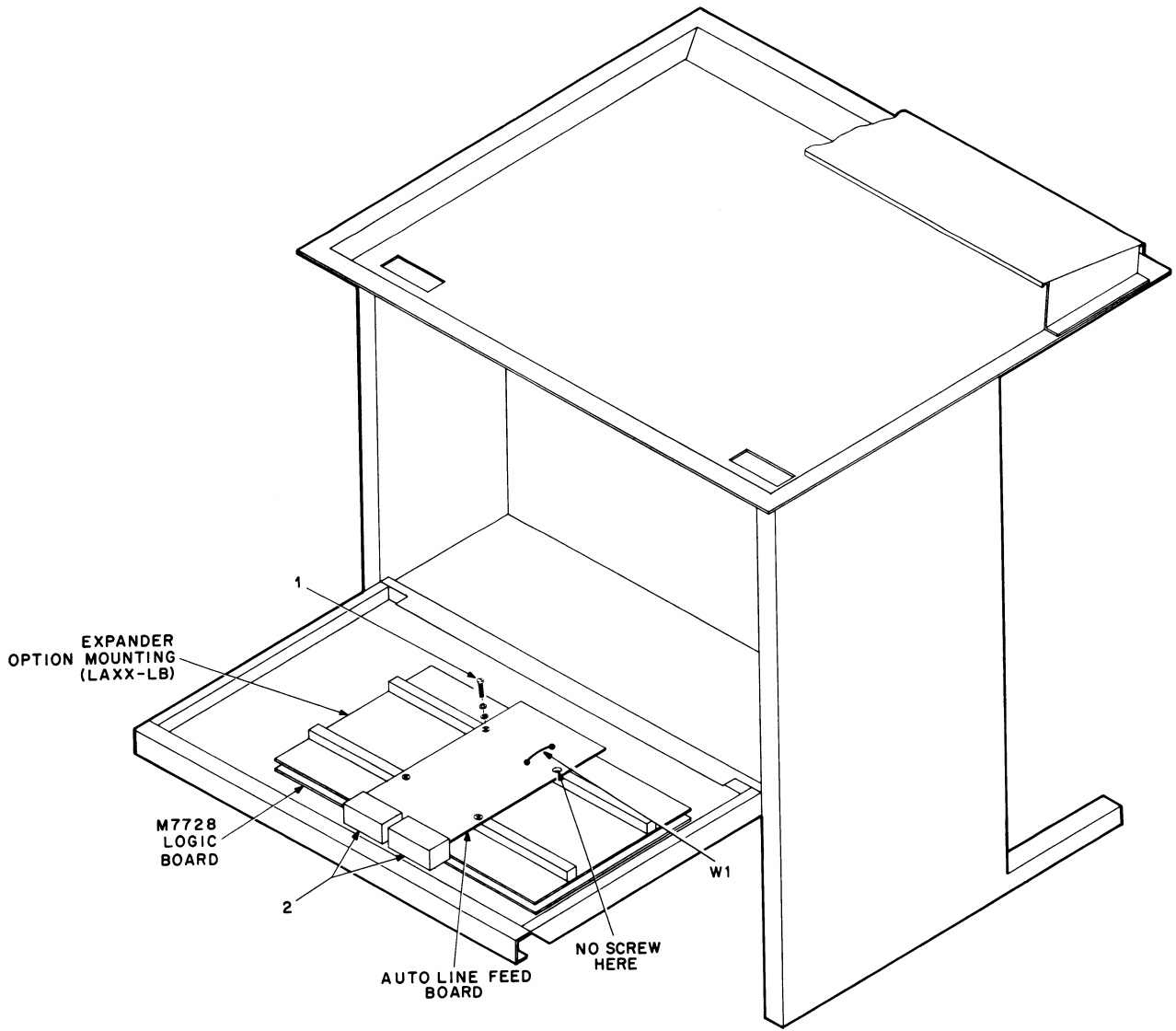

Figure 14 Installation of Automatic Line Feed Option (LAXX-LA)

5. Install the two H851 edge connectors (2). Edge connectors and board are keyed for proper fit.

Test After Installation – Load paper and energize. In the local mode, with the front panel AUTO LF switch in the up position, type RETURN; a carriage return and one line feed should occur. Press the AUTO LF switch and type RETURN; a carriage return and two line feeds should occur.

SELECTIVE ADDRESSING OPTION KIT (LAXX-KW)

The Selective Addressing Option Kit contains the following:

Quantity	Item	Part Number
1	Selective Addressing	D-CS-M7737-0-1
1	Edge Connector Board	B-UA-H851-0-0
2	Phillips Pan Head Nylon Screws (#4-40 X 0.38 in.)	9006401-04
1	EIA Interface Cable	C-IA-7010489-0-0

A Phillips screwdriver is the only tool required for installation. Use Figure 15 and the following procedure as installation guides.

1. Unplug the ac power cord.
2. If not already installed, install the Expander Option Mounting Kit (LAXX-LB).
3. Refer to Figure 8 for the correct interface cabling required to integrate the Selective Addressing Option into the existing options.
4. Using the supplied hardware (3) (two #4-40 X 0.38-in. screws), secure the Selective Addressing board in location E on the expander board.
5. Install the H851 edge connector (2). Edge connector and board are keyed for proper fit.
6. If the Selective Addressing Option is to be used with the EIA Interface Option (LAXX-LG), the interface cable (1) should be connected as shown (lug G on the EIA board to lug GND on the Selective Addressing board).

Test After Installation – Perform the following procedure:

1. Properly interface the DECwriter with the Selective Addressing option to another DECwriter without this option. (EIA interface or any other type of communications interface is acceptable.)
2. Energize both terminals; set both to the same baud rate, line mode, and full duplex operating conditions.

NOTE

In the following procedure, the terminal *with* the Selective Addressing Option is designated as "A" and the terminal *without* the option designated "B."

3. On terminal A, the front panel SELECT AVAIL light is illuminated.
4. On terminal A, type CTRL D. The SELECT AVAIL and DEVICE SELECT lights will be illuminated on terminal A.
5. On terminal A, type CTRL SPACE (NULL), then type CTRL B. Both terminals can send and receive.
6. On terminal A, type CTRL D. The DEVICE SELECT light extinguishes.
7. Type any character on terminal B; it is not printed by A. The SELECT AVAIL light on terminal A extinguishes. A cannot send or receive.

NOTE

Steps 8 and 9 set up terminal A as a broadcast selected slave.

8. On terminal B, type CTRL SPACE, CTRL G, then type CTRL B. Terminal A can receive from B, but not send.
9. On terminal B, type CTRL D. On terminal A, the SELECT AVAIL light illuminates.

NOTE

Steps 10 through 13 set up terminal A as a group selected slave.

10. On terminal B, type any characters. The SELECT AVAIL light on terminal A extinguishes.

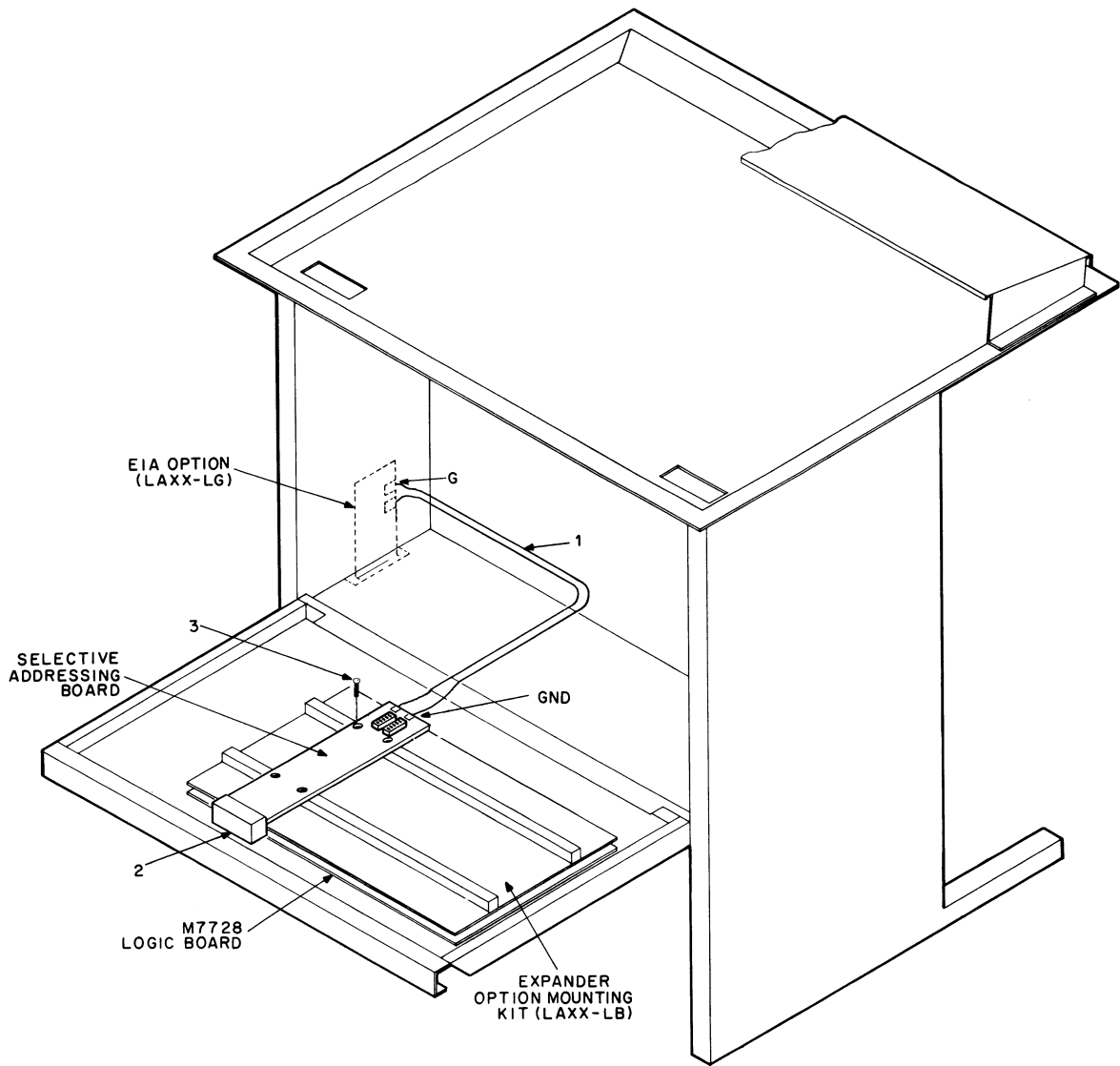

CP-2109

Figure 15 Installation of Selective Addressing Option Kit (LAXX-KW)

11. On terminal B, type the group select code that was entered into the switches on the Selective Addressing circuit board installed in terminal A.
12. On terminal B, type CTRL B. Terminal A can receive from B, but not send.
13. On terminal B, type CTRL D. On A the SELECT AVAIL light illuminates.

NOTE

Steps 14 through 18 set up terminal A as a uniquely selected slave (case 1).

14. On terminal B, type any characters. The SELECT AVAIL light on terminal A extinguishes.
15. On terminal B, type A's unique select code that was entered into the switches on the Selective Addressing circuit board installed in terminal A.
16. On terminal A, the DEVICE SELECT light illuminates.
17. On terminal B, type CTRL E, then CTRL B. Both terminals can send and receive. If the Answerback Option is installed in terminal A, the answerback message will print on terminal B after CTRL E is typed.
18. On terminal B, type CTRL D. On A, the DEVICE SELECT light extinguishes and the SELECT AVAIL light illuminates.

NOTE

Steps 19 through 21 set up terminal A as a uniquely selected slave (case 2).

19. Repeat steps 14 through 16.
20. On terminal B, type CTRL E, then any character (A's DEVICE SELECT extinguishes), then CTRL B. Terminal A can receive but not send.
21. On terminal B, type CTRL D. On terminal A, the SELECT AVAIL light illuminates.

NOTE

Steps 22 and 23 set up terminal A as a uniquely selected slave (case 3) with add-on capability.

22. On terminal B, type any characters. The SELECT AVAIL light on terminal A extinguishes. Then type CTRL B.
23. On terminal B, type A's unique select code. The DEVICE SELECT light on A does not illuminate; then type CTRL C and A's code again. The DEVICE SELECT light illuminates now.
24. On terminal B type CTRL B. Both terminals can send and receive. Then type CTRL D. The DEVICE SELECT extinguishes and SELECT AVAIL light illuminates on terminal A.

AUTOMATIC ANSWERBACK OPTION KIT (LAXX-KX)

The Auto Answerback Option Kit contains the following:

Quantity	Item	Part Number
1	Auto Answerback Board	D-CS-M7733-0-1
2	Edge Connectors	B-UA-H851-0-0
4	Phillips Pan Head Screw (#4-40 X 0.38 in.)	9006011-1
4	Lock Washers (#4)	9006688
4	Flat Washers (#4)	9006655

A Phillips screwdriver is the only tool required for installation. Use Figure 16 and the following procedure as installation guides.

1. Unplug the ac power cord.
2. If not already installed, install the Expander Option Mounting Kit (LAXX-LB).
3. Refer to Figure 8 for the correct interface cabling required to integrate the Auto Answerback Option.
4. Using the supplied hardware (1) (four #4-40 X 0.38-in. screws and associated washers), secure the Auto Answerback board in locations C and D on the expander board.

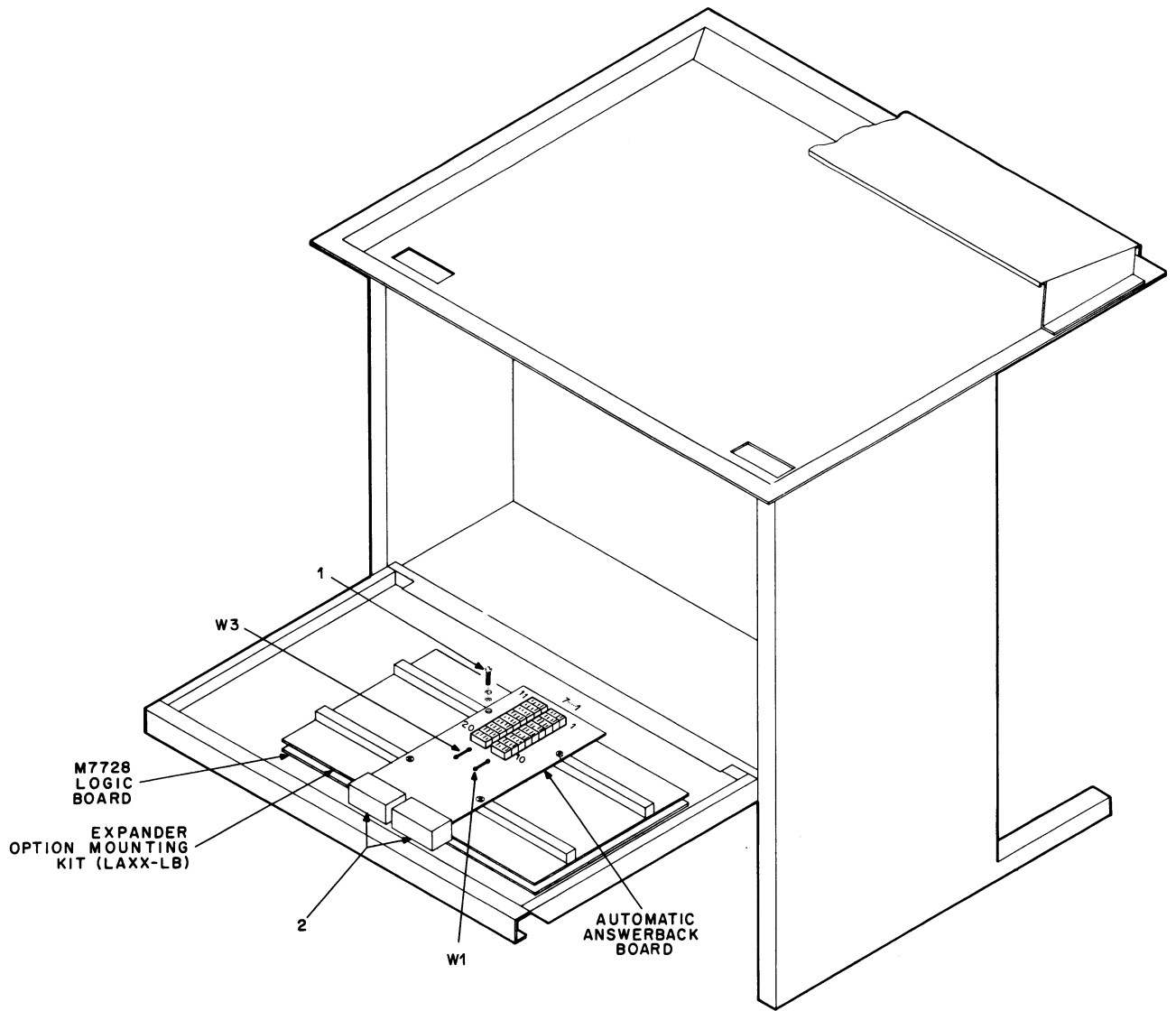

CP-2110

Figure 16 Installation of Automatic Answerback Option Kit (LAXX-KY)

5. Install the two H851 edge connectors (2). Edge connectors and board are keyed for proper fit.
6. Enter the answerback message using the 7 slide switches on the 20 character switches. Use the standard ASCII code. The ON switch position is the asserted state (high) and slide switch No. 1 corresponds to b1 of the 7-bit character.

Test After Installation – Install paper and energize. In the local mode, pressing the front panel HERE IS switch institutes a printout of the answerback message. When on-line, a received ENQ command (005₈) will generate the answerback message.

In the local mode, with the front panel AUTO LF switch in the up position, type RETURN; a carriage return and one line feed should occur. Press the AUTO LF switch and type RETURN; a carriage return and two line feeds should occur.

EIA INTERFACE OPTION KIT (LAXX-LG)

The EIA Interface Option Kit contains the following:

Quantity	Item	Part Number
1	EIA Interface Assembly	D-IA-7011828-0-0
2	Phillips Pan Head Screws (#8-32 X 0.38 in.)	9006037-1
2	Lock Washers (#8)	9006690-00
2	Flat Washers (#8)	9006660-00

A Phillips screwdriver is the only tool required for installation. Use Figure 17 and the following procedure as installation guides.

1. Unplug the ac power cord.
2. Disconnect the 20 mA interface input cable from J3 on the M7728 logic board.
3. Remove the two screws that hold the 20 mA interface cover plate to the floor of the cabinet and remove the complete harness assembly.
4. Insert the connector end (1) of the EIA interface cable up through the hole in the floor, then insert the EIA circuit board assembly (2).
5. Using the #8-32 X 0.38-in. screws and washers (3) supplied, secure the EIA assembly.
6. Plug the connector (1) into J4 of the M7728 logic board.

7. Connect the input end of the EIA cable assembly to the signal source.

The EIA circuit board has two wire jumpers that allow selection of the type of BREAK and DATA TERMINAL READY signals that are output by the EIA interface. Depending on the presence of these jumpers, any of the following four terminal conditions produce the output signals.

- Paper Out
- Switch to Local Mode
- Power-up Sequence Not Completed
- Terminal Power Switched Off

The status of these jumpers produce the following outputs for any of the above conditions.

W1	W2	EIA Output Signal
Out	Out	None
Out	In	230 ms BREAK on Transmit Data Line
In	Out	DATA TERMINAL READY
		Disconnect

NOTE

The EIA board is shipped with both jumpers installed.

NOTE

The CARRIER DETECT signal can cause a DATA TERMINAL READY disconnect regardless of jumper presence.

Test After Installation – Send EIA data into the DEC-writer; the printout should verify a correct installation.

14-KEY NUMERIC PAD OPTION KIT (LAXX-KE)

The 14-Key Numeric Pad Kit contains:

Quantity	Item	Part Number
1	Bezel	E-IA-7411427-2-0
1	LK03A Numeric Keyboard Assembly	C-UA-LK03-A-0
1	Numeric Pad Cable	C-IA-7008612-0-0
4	Standoff Spacers	900928500
4	Kep Nuts	9006563-00

A Phillips screwdriver and a 11/32-in. nut driver are the only tools required for installation. Use Figure 9 plus the following procedure as installation guides.

1. Unplug the ac power cord, take the top cover off, remove the paper, and remove the plastic housing.

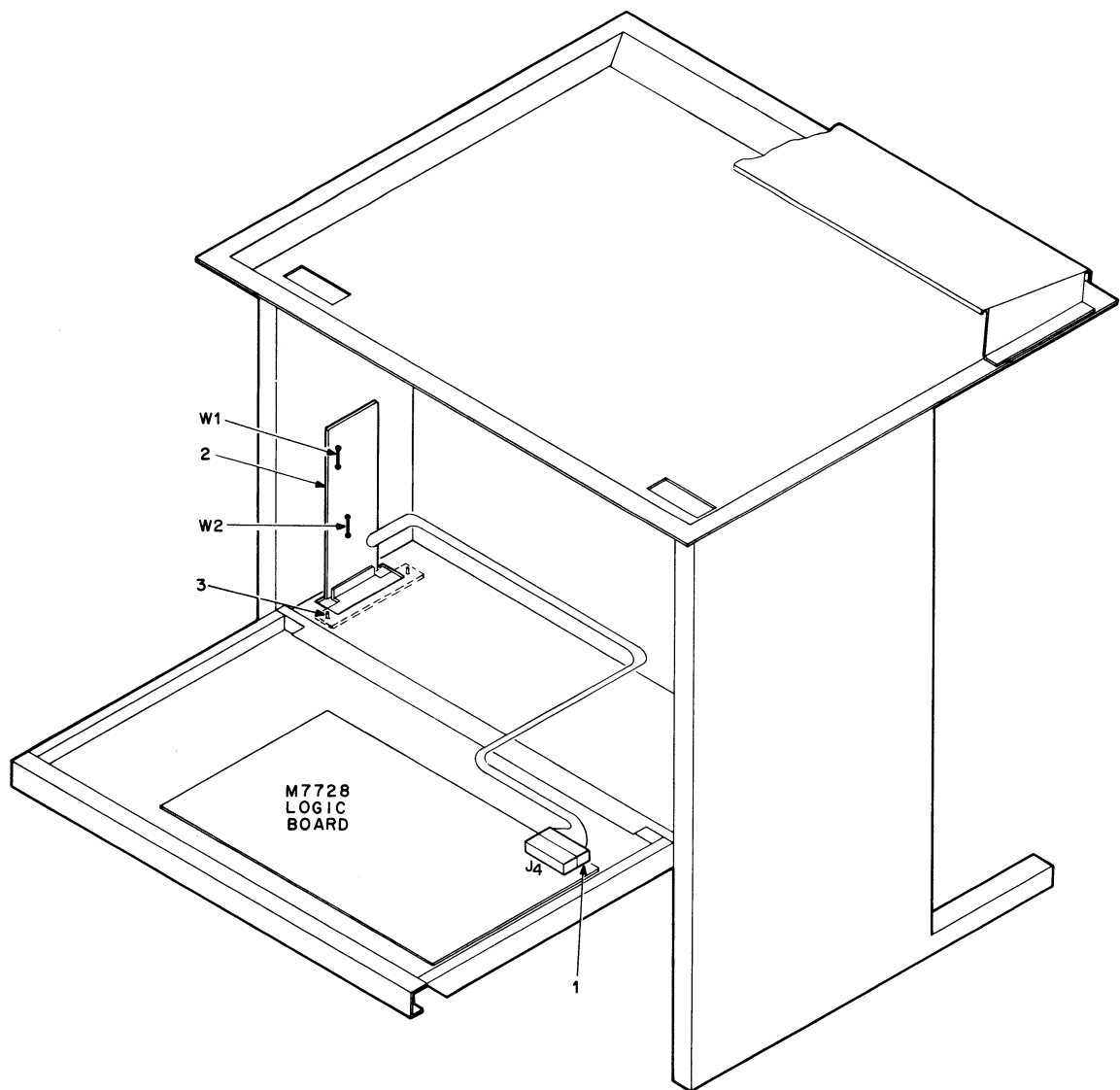

CP-2111

Figure 17 Installation of EIA Interface Option Kit (LAXX-LG)

2. Refer to Figure 9. Remove the four screws, lock washers, flat washers (1), and spacers (2) that secure the keyboard bezel to the cabinet base.
3. Turn the keyboard upside down on a piece of foam or bubble plastic and remove the four Kep nuts (3) that secure the keyboard to the bezel. Remove the four Kep nuts (9) that secure the control panel to the bezel.
4. Remove all eight standoffs from the old bezel and attach them, and the four standoffs supplied with the kit, on the new bezel as shown in Figure 9.
5. Connect one end of the numeric pad cable (6) to J1 on the keyboard. Connect the other end to the connector on the numeric pad (3). Ensure the red stripe is positioned as shown in Figure 9.
6. Carefully replace all three assemblies (control panel, keyboard, and numeric pad) on their respective standoffs and secure with the Kep nuts. Provide adequate cable clearances around all standoffs.

CAUTION

Ensure that all insulating washers are installed between the Kep nuts and the etch side of the circuit boards. Failure to insert washers at required points may cause circuit damage.

The keyboard cable (5 in Figure 9) must be routed to the inside of standoff (8) and between the bezel and the component side of the keyboard. This prevents possible interference between cable and print head assembly.

7. Replace the bezel on the cabinet base and secure with the four screws, lock washers, flat washers, and spacers.

CAUTION

The keyboard bezel should be positioned as far forward (toward operator) as possible to eliminate interference between the keyboard cable and print head assembly.

Ensure that the spacers are placed under the bezel. Failure to do so may result in damage to the print head because of interference with the keyboard connector.

8. Replace and secure the plastic housing. Replace the cover and install paper.

Test After Installation – Apply power and place it in local mode. The keys on the numeric pad will produce numeric characters just as if they were typed on the main keyboard.

COMPRESSED FONT OPTION KIT (LAXX-KJ)

The Compressed Font Option Kit contains the following:

Quantity	Item	Part Number
1	30-Tooth Timing Pulley	1212446-00
1	15-Tooth Timing Pulley	D-MD-7414908-0-0
1	Pulley Clamp	C-MD-7414951-0-0
1	Timing Belt	1211583-02
1	Socket Head Cap Screw (#10-32 X 1 in.)	9006350-8
1	Hex Socket Set Screw (#¼-20)	9007722-10
2	Kep Nuts	9006565-00
1	Right-Hand Spacer	C-MD-7415010-0-0
1	Channel Strip	9007036-00

The following tools are required for installation: socket head wrenches, Phillips screwdriver, feeler gauges, and a torque-type Phillips screwdriver. Use Figures 18 and 19 and the following procedure as installation guides.

1. Remove ac power from the DECwriter and remove the top cover and plastic housing.
2. Remove the ribbon from the print head area.
3. Press in against the spring as in 1, Figure 18, to remove belt tension, then slide the timing belt (2) off both existing pulleys (3) and (4).
4. Using a socket head wrench, loosen the set screw in the pulley clamp (5) until the existing timing pulley (3) can be removed from the motor shaft. This pulley clamp can be discarded.
5. Loosen the set screw in the other pulley clamp (4), then remove and save this pulley.

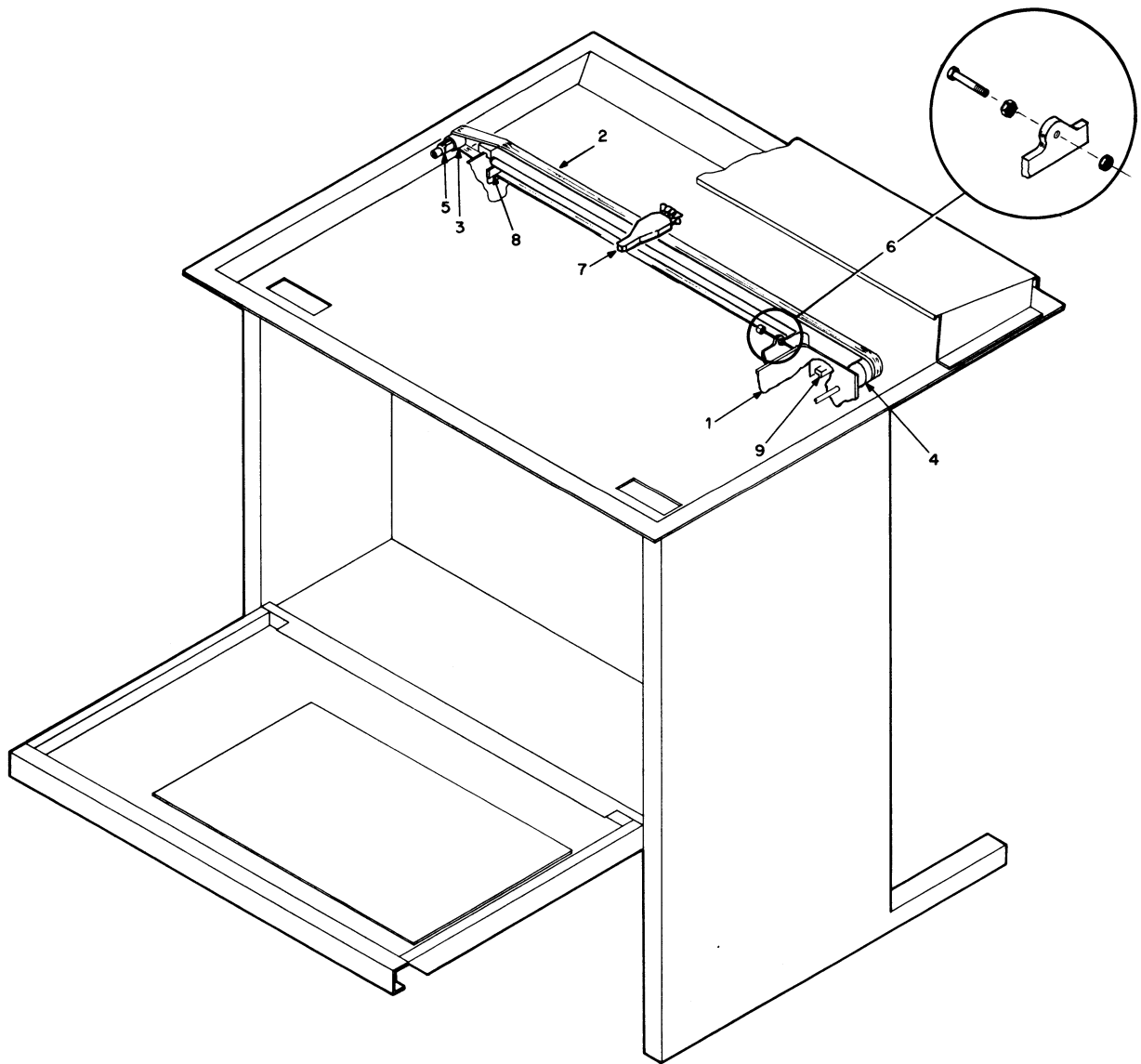

CP-2113

Figure 18 Installation of Compressed Font Option Kit (LAXX-KJ)

6. Assemble the cap head screw and Kep nuts, then insert through the left side bracket as shown in (6).
7. Install the new 30-tooth timing pulley on the ribbon drive shaft (4). The side of the pulley with the flange should be positioned toward the front of the machine. Position the pulley so that there is 9/32-in. clearance between the back of the pulley and the mounting hardware for the shaft bearing. Secure the new 30-tooth pulley using the previously removed pulley clamp.
8. Install the new 15-tooth pulley on the motor shaft and secure, using the new pulley clamp provided.
9. Remove the four screws (7) that secure the print head and replace the existing timing belt with the new belt supplied. Reassemble the print head but do not tighten the four mounting screws.
10. Set the Carriage Adjustment lever to the minimum gap position (detent closest to the print bar).

CAUTION

It is possible to position the Carriage Adjustment lever beyond the minimum gap position. If this is done, the correct head gap adjustment cannot be made.

11. Adjust the print head gap with the carriage in the center of travel. Place a 0.012-in. flat feeler gauge between the print head jewel and the front surface of the print bar (parallel to the print bar). Push the print head snug against the feeler (Figure 19).

CAUTION

Ensure that the feeler gauge rides between the protrusions on the print head. A feeler gauge with a width of 7/16 in. (or less) is needed to fit between the protrusions. Do not exert excessive force on the print head when making the adjustment; it will cause the carriage shaft to bow, resulting in more than 0.012 in. of clearance.

12. Tighten the #4 (6-32) screws to 10 ± 2 in./lb of torque.

CAUTION

Do not apply more than the recommended torque when tightening the print head screws or the moulded inserts in the carriage assembly may be damaged.

13. Move the print head to the extreme right and left. Using a feeler gauge, check each position for no

less than 0.010 in. of clearance between print head and print bar.

14. Recheck the gap at the center. The gap should be no greater than 0.014 in. If it is, perform steps 10 through 14 again.
15. Press against the ribbon drive assembly spring and install the new timing belt on both pulleys.
16. Adjust the cap head screw (6) so that the space between the end of the screw and the ribbon drive assembly bracket is between 0.005 and 0.010 in.
17. Rethread the ribbon, replace the plastic housing and top cover, insert paper, and apply power.

NOTE

U.S.-built LA36s with serial number 02-23374 (or Ireland-built 04-10050) and earlier require spacers as shown in (8) and (9). The right spacer (8) is inserted over the end of the side bracket and between the bracket and the carriage shaft. When loosening the socket head cap screw at the right end of the carriage shaft, do not allow the shaft to turn. The channel strip spacer (9) slips over the left side bracket as shown to prevent the timing belt from chaffing.

Test After Installation — The DECwriter will print 132 characters in a line that is 8 in. wide. All other normal functions are unaffected.

PAPER OUT OPTION KIT (LAXX-KZ)

The Paper Out Option Kit contains the following:

Quantity	Item	Part Number
1	Paper Out Cable	C-1A-7011657-0-0
1	Micro Switch Assembly	D-MD-7412424-0-0
2	Phillips Pan Head Screws (#4-40 X 9/16 in.)	9008033-1
2	Kep Nuts (#4-40)	9006557
2	Flat Washers (#4)	9006655
2	Tie Wraps (5-½ in. X 1/8 in.)	9007880

A Phillips screwdriver and a pair of needle-nose pliers are recommended tools for installation. Use Figures 9 and 20 plus the following procedure as installation guides.

1. Unplug the ac power cord. Remove the paper. Remove the top cover and plastic housing.

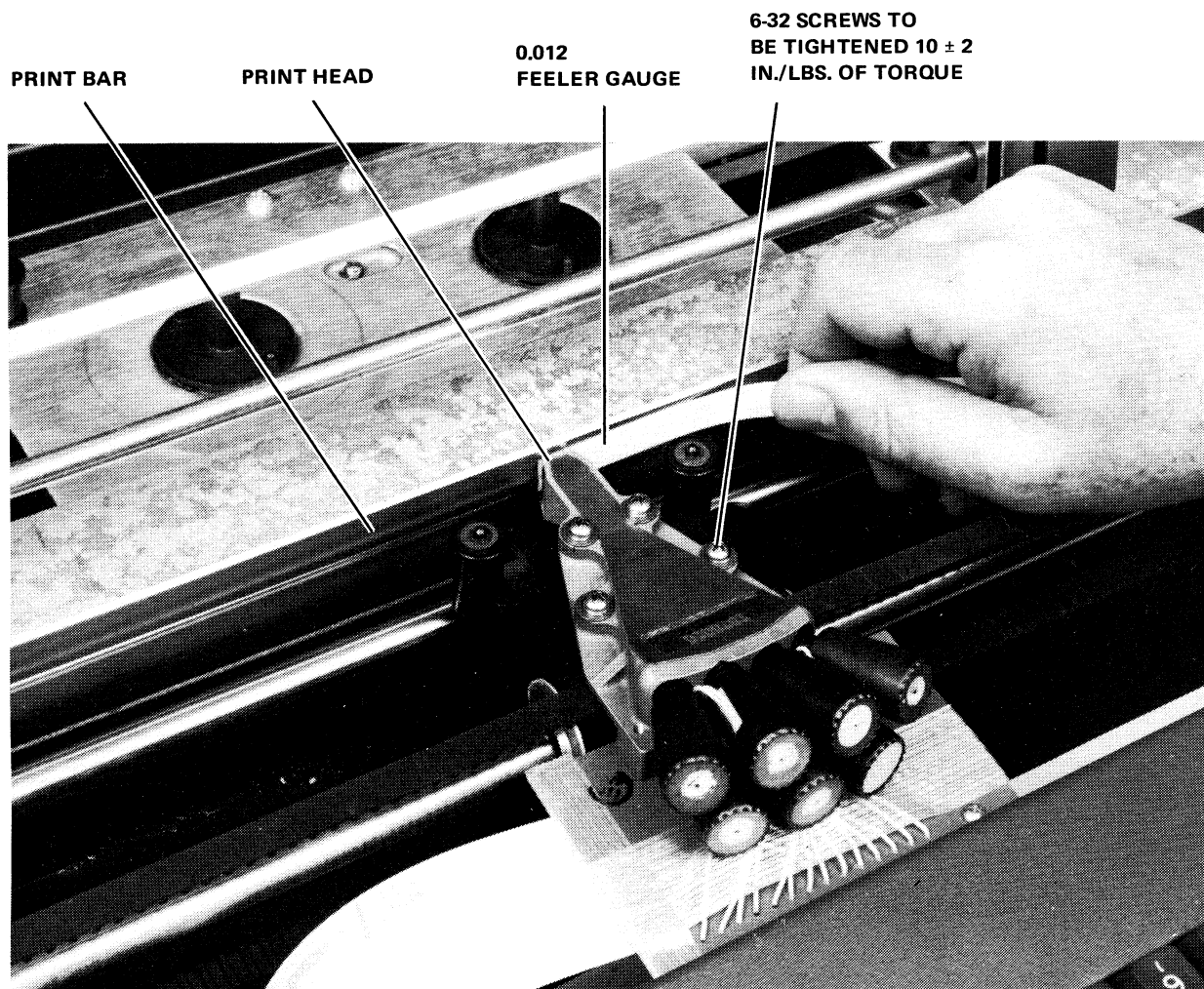

CAUTION
ENSURE THAT FEELER GAUGE IS INSERTED
BETWEEN THE PROTRUSIONS ON THE
PRINTHEAD. FAILURE TO DO SO WILL RESULT
IN IMPROPER CLEARANCE AND SHORTEN
THE LIFE OF THE PRINTHEAD.

7393-06

Figure 19 Print Head Adjustment

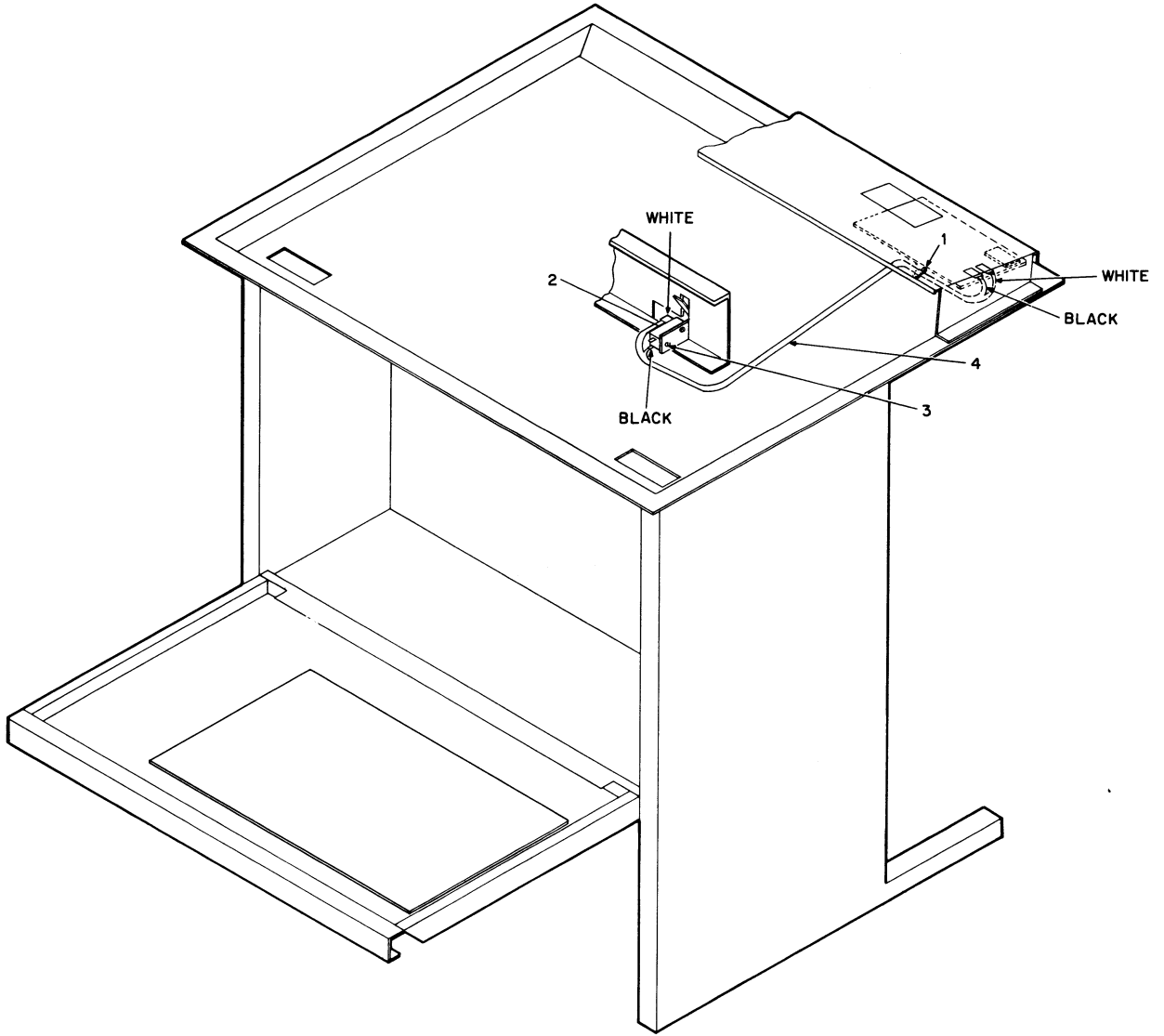

CP-2114

Figure 20 Installation of Paper Out Option Kit
(LAXX-KZ)

2. Using the two screws, washers, and nuts (3), mount, but do not tighten, the PAPER OUT switch (2) on the paper guide.
3. Connect the cable end (4) having the two smaller connectors to the PAPER OUT switch as follows: black to bottom, white to top.
4. Cut the first two cable ties (1) holding the keyboard cable to the anchors.
5. Form the paper out cable along the keyboard cable and secure both to the anchors using the supplied cable ties.
6. Refer to Figure 9 and remove the four screws, lock washers, flat washers (1) and spacers (2) that secure the keyboard bezel to the cabinet base, Turn the bezel upside down on a piece of foam.
7. Using the needle-nose pliers, attach the paper out cable white lead to the frontmost connector and then the black lead to the other connector.
8. Insert a piece of paper up through the paper guide. Plug the DECwriter into an ac source and then energize the unit.
9. Manually activate the PAPER OUT switch to ensure proper connections. The front panel PAPER OUT switch should illuminate and extinguish as the switch is operated. If not, recheck all connections.
10. Adjust the PAPER OUT switch so that the PAPER OUT light is extinguished when paper is correctly installed. Remove the paper; the light should illuminate. Continue to readjust the PAPER OUT switch until the proper indication is achieved in both states.
11. Replace the housing and top cover.

Test After Installation – Check for the correct indication of the PAPER OUT display light when approximately 2 in. from the end of paper.

20 MA CABLE OPTION KIT (LAXX-LH)

The 20 mA Cable Option Kit contains the following:

Quantity	Item	Part Number
1	Cable	BC05F-15
1	Cover Plate	C-MD-7413216-0-0
2	Phillips Pan Head Screws (#8-32 X 0.38 in.)	9006037-1
2	Flat Washers (#8)	9006660
2	Lock Washers (#8)	9006634

A Phillips screwdriver is the only tool required for installation. Use Figure 21 and the following procedure as installation guides.

1. Disconnect and remove any previously connected data input line.
2. Insert the connector end (4) of the 20 mA cable up through the access hole in the floor and connect it to J3 on the M7728 logic board.
3. Secure the cover plate (3) using the two pan head screws and associated washers (2). Position the cable (1) as shown.
4. Connect the input end of the 20 mA cable assembly to the signal source.

Test After Installation – Send data into the DECwriter; the printout should verify a correct installation.

20 MA (DEC 10) CABLE OPTION KIT (LAXX-LK)

The 20 mA Cable Option Kit contains the following:

Quantity	Item	Part Number
1	Cable (2838 Connector to Mate-N-Lok Connector)	D-AI-7009212-1-0
1	Cover Plate	C-MD-7413216-0-0
2	Phillips Pan Head Screws (#8-32 X 0.38 in.)	9006037-1
2	Flat Washers (#8)	9006660
2	Lock Washers (#8)	9006634

A Phillips screwdriver is the only tool required for installation. Use Figure 22 and the following procedure as installation guides.

1. Disconnect the remove any previously connected data input line.
2. Insert the connector end (4) of the 20 mA cable up through the access hole in the floor and connect it to J3 on the M7728 logic board.
3. Secure the cover plate (3) using the two pan head screws and associated washers (2). Position the cable (1) as shown.
4. Connect the input end of the 20 mA cable assembly to the signal source.

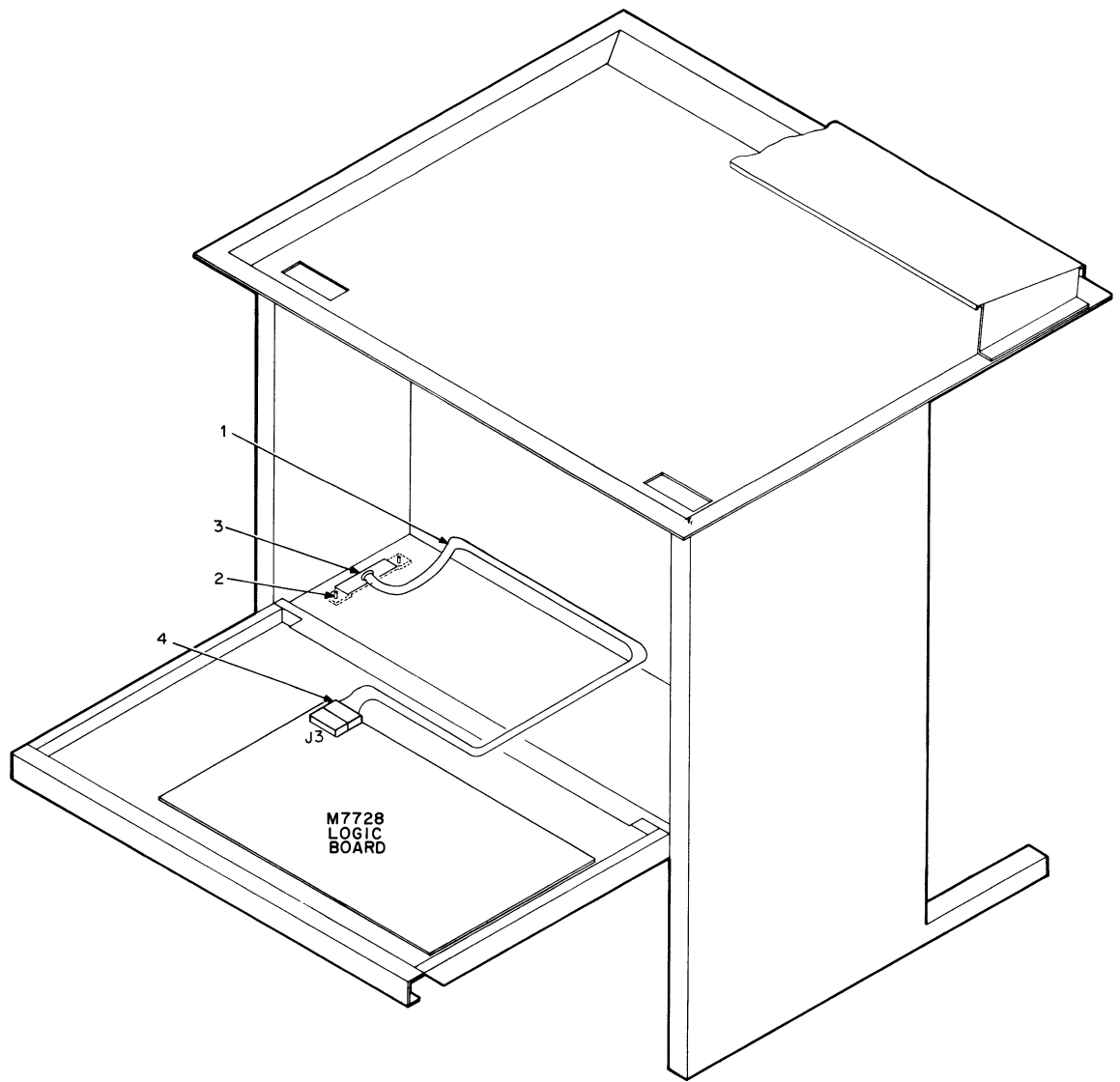

CP-2115

Figure 21 Installation of 20 mA Cable Option Kit (LAXX-LH)

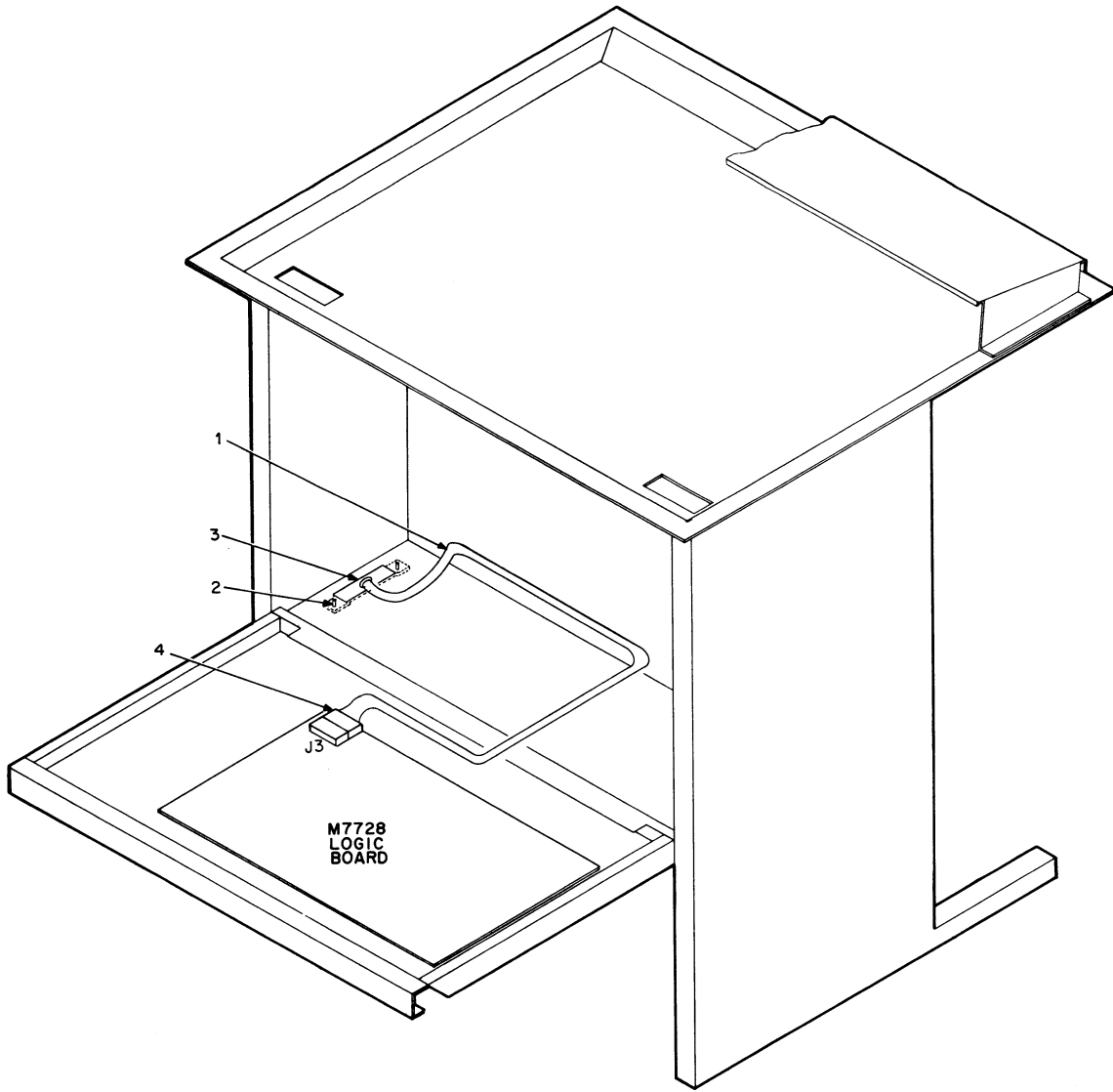

CP-2115

Figure 22 Installation of 20 mA (DEC 10) Cable Option Kit (LAXX-LK)

Test After Installation – Send data into the DECwriter; the printout should verify a correct installation.

SCALE, POINTER, AND WINDOW OPTION KIT (LAXX-LN)

The Scale, Pointer, and Window Option Kit contains the following items:

Quantity	Item	Part Number
1	Column Scale	C-IA-7414986-0-0
1	Line Indicator	C-MD-7414953-0-0
1	Column Pointer	C-MD-7415409-0-0
1	Print Window	1212009-00
1	Light Shield	C-MD-7415255-0-0
1	Phillips Pan Head Screw (#4-40 X 3/8-in.)	9006011-1
1	Flat Washer (#4)	9008172
1	Lock Washer (#4)	9006632

A Phillips screwdriver is the only tool required for installation. Use Figures 2 and 23 plus the following procedure as installation guides.

1. Unplug the ac power cord, remove the paper, and then remove the top cover.
2. Install the line indicator (1) on the print head assembly using the two front Phillips screws. Remove the screws, insert the line indicator beneath the ribbon (do not interfere with the ribbon's path), then secure with the screws.
3. The column pointer (2) and its associated spacer are manufactured as a single unit. The spacer is attached to the side of the pointer by a thin web. Before installing the pointer, these two parts must be separated at this web. Fold the spacer down under the pointer to break apart.
4. Install the column pointer and spacer on the line indicator using the #4 screw, lock washer, and flat washer (3).

NOTE

If after installing the print window, the red and green positioning lines on the column pointer seem to be too high above the lip of the window, remove the spacer from beneath the column pointer.

5. The light shield (4) is a flat-black surface that minimizes glare and reflections. The shield mounts on the sloped surface of the top cover. Peel off the backing and position on the cover.
6. The column scale (5) adheres to the lip on the print window (6) as shown in Figure 23. Insert A of Figure 23 details the placement of the scale on the window lip.
7. The print window (6) snaps into place in the top cover opening.
8. After loading paper, energize and place the DECwriter in the local mode.
9. Type the letter "N" five times.
10. After the Last Character Visibility (LCV) shift, press the BACKSPACE key once.
11. The right-hand vertical ascender of the last "N" typed should align over the right edge of the line indicator as shown in insert B of Figure 23. If necessary, loosen the two screws that secure the line indicator to the print head and correct the alignment.
12. After aligning the line indicator, close the cover, press RETURN, then type any printable character.
13. After the LCV occurs, the red line on the column pointer should align with the line on the column scale that corresponds to column No. 2. If not, open the cover and loosen the screw that secures the column pointer to the line indicator and adjust the position of the column pointer. Repeat steps 12 and 13 until the red line is in the proper position.

NOTE

Prior to the LCV, the green line on the column pointer aligns with the column scale to indicate the column in which the next character will print.

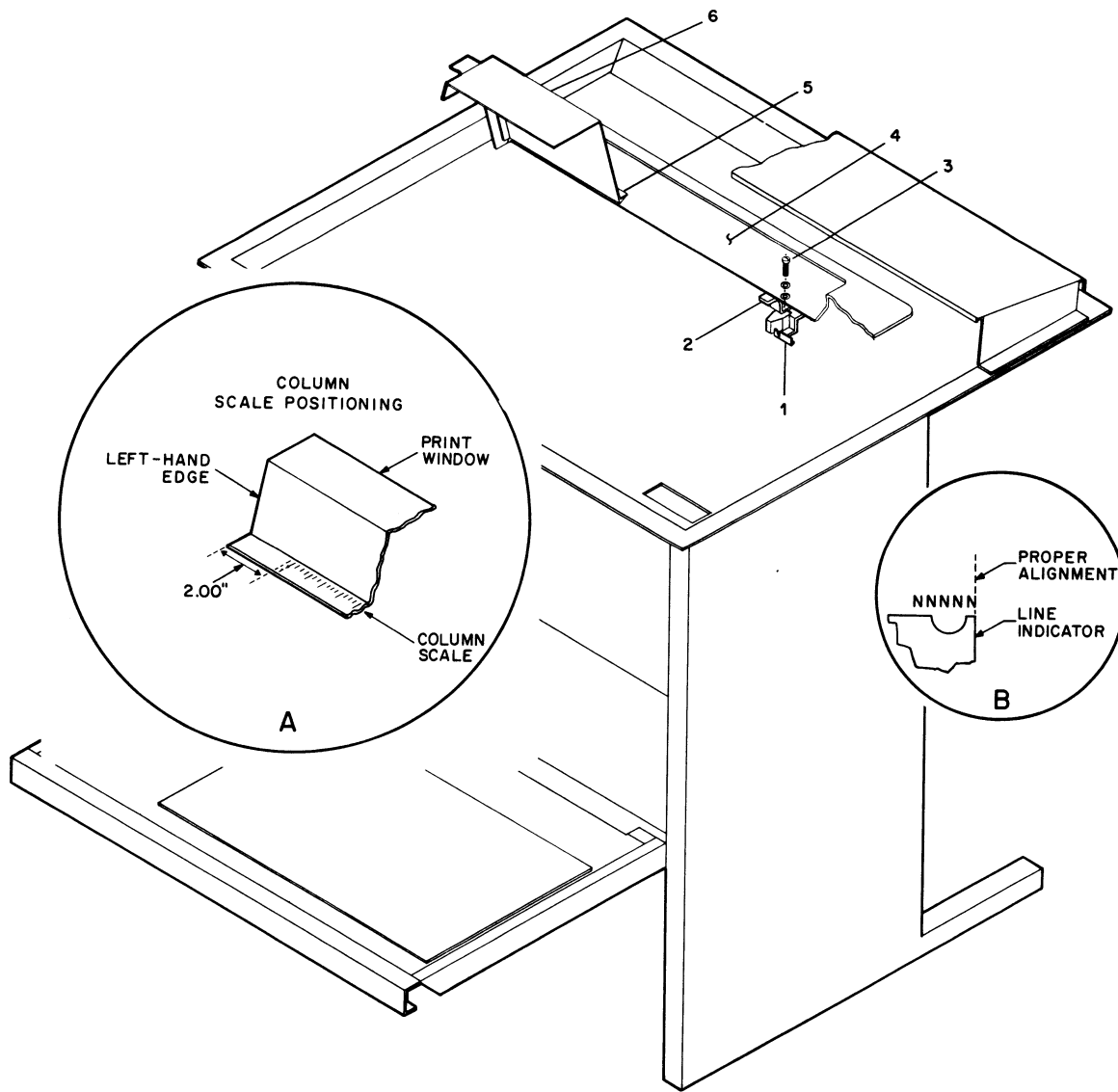

CP-2117

Figure 23 Installation of Scale, Pointer, and Window Option Kit (LAXX-LN)

DF11 ADAPTOR KIT (LAXX-KH)

The DF11 Adaptor Kit contains the following:

Quantity	Item	Part Number
1	Adaptor Bracket	C-MD-7413104-0-0
1	Wired Assembly	B-IA-7010599-0-0
1	Cable Assembly	C-IA-7010598-0-0
2	Phillips Pan Head Screws (#2-56 X 1/4-in.)	9006001-01
1	Phillips Pan Head Screw (#6-32 X 7/16-in.)	9006023-01

A Phillips screwdriver is the only tool required for installation. Use Figure 24 and the following procedure as installation guides.

1. Secure the adaptor bracket (1) to the cabinet door as shown. Use two #6-32 screws.
2. Attach the wired assembly (2) to the bracket with a #6-32 screw (3).
3. The cable assembly (4) should be soldered to the wired assembly as in Figure 24.
4. Connect the cable connector to J4 on the logic board.
5. Insert the DF11 communications option into the connector in the wired assembly (2) and secure the other end to the adaptor bracket using the two small screws supplied (#2-56). The screws insert through the hollow rivets in the DEC-CHIP handle and secure into the adaptor bracket at (5).

Test After Installation – Refer to the checkout procedures for the DF11 module installed.

ACOUSTICAL COUPLER OPTION KIT (LAXX-LM)

The Acoustical Coupler Option Kit contains a new cover (D-AD-7012144-0-0) that replaces the existing LA36 cover and a rubber "O" ring (9009793-00) that fits over the tractor drive shaft to minimize mechanical noise generation during a paper advance. A Phillips screwdriver is the only tool required for installation.

Use Figures 25 and 26 plus the following procedure as installation guides.

1. Unplug the ac power cord and remove the existing top cover.
2. Remove the Paper Advance knob (2, in Figure 25) by unscrewing the #6 screw (1, in Figure 25) from the center of the knob.
3. After removing the Paper Advance knob from the tractor drive shaft (4, in Figure 25) remove and discard the sleeve (5), then slide two "O" rings (3, in Figure 25) all the way onto the shaft.
4. Replace the knob on the tractor shaft and secure with the screw and washers.
5. Insert the new cover onto the DECwriter. Press the acoustical coupler cable down through the rear access hole as shown in Figure 26.
6. Connect the cable end into the EIA connector (J4) on the logic board.

Test After Installation – Perform the following procedure:

1. Set for power on, on-line, and correct baud rate.
2. Using a telephone, call the sending system and, after hearing the carrier, place the handset into the muff assembly.
3. The carrier light illuminates within 5 seconds and then normal system operation can be performed.

NOTE

The cord end of handset is placed in muff with "dot" and/or word "CORD" next to it.

NOTE

Before removing the telephone handset from the muff assembly, place the DECwriter in the local mode. This action prevents the disconnect noise from causing printing of random characters.

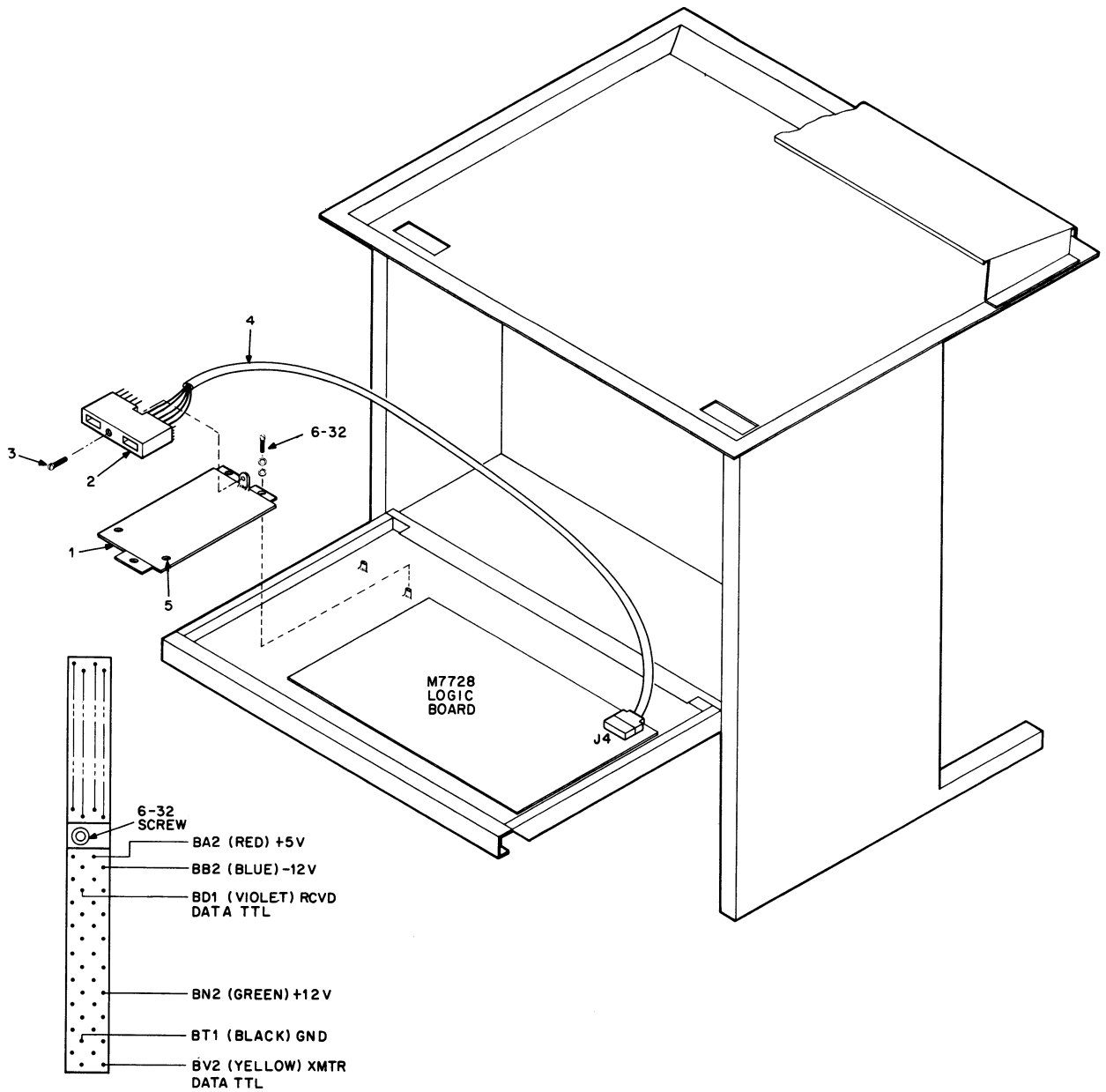

CP-2118

Figure 24 Installation of DF11 Adaptor Mounting Kit (LAXX-KH)

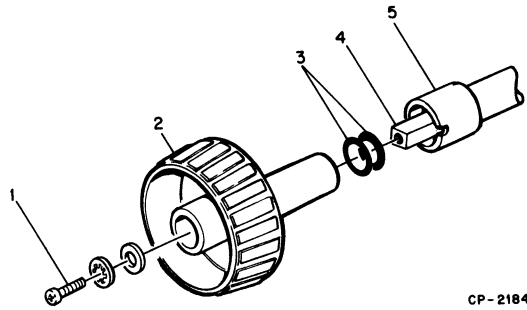

CP-2184

Figure 25 Installation of "O" Ring on Tractor Drive Shaft

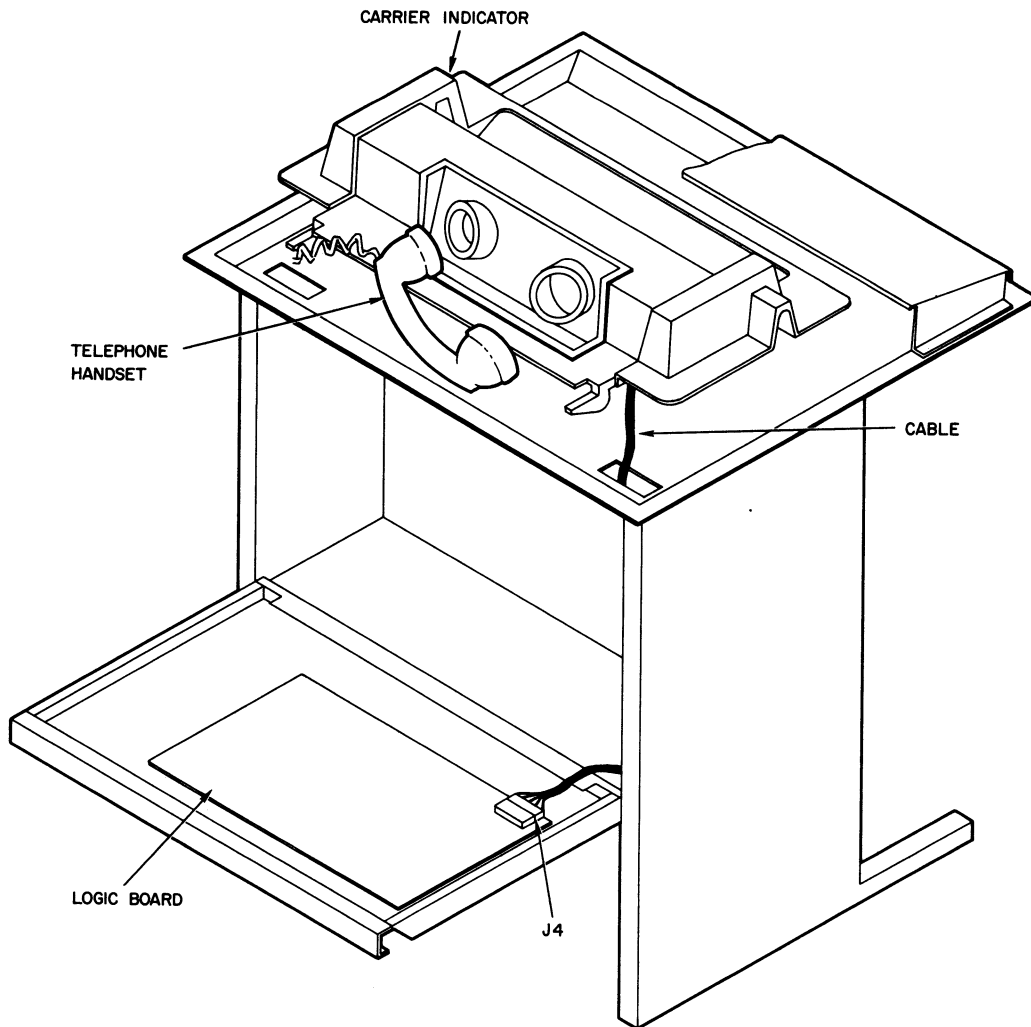

CP-2190

Figure 26 Installation of Acoustical Coupler Option Kit (LAXX-LM)

SECTION 2
LA35 USER'S INFORMATION

LA35 GENERAL INFORMATION

INTRODUCTION

The LA35 DECwriter is a medium-sized, low-cost printer for use as a local or remote printer only. It is capable of handling multipart and multiform line printer paper from 3 to 14-7/8 in. (7.62 to 37.78 cm) wide. It is especially suited for preprinted forms due to its horizontal and vertical positioning capabilities.

OPTIONS

The basic LA35 DECwriter can be expanded to provide the user with a number of functional options for receiving and handling data. These functional options are described in the following table.

LA35 Options

Option	Name	Description
LAXX-LB	Expander Option Mount	The Expander Option Mounting Kit includes the logic, cables, and mounting hardware required to expand the LA35 to include options LAXX-LA, LAXX-KV, LAXX-KW, LAXX-KX, LAXX-KY, and LAXX-PK.
LAXX-PK	APL/ASCII Dual Character Set	This option provides an APL alternate character set for use with the standard character set in the LA35.
LAXX-LA	Auto LF After CR	The LAXX-LA option causes the printer to execute a line feed after each received carriage return code.
LAXX-KV	Top of Forms Control	Controls mounted under the top cover provide the operator with a method of selecting the length of the paper to be used. After the desired setting is selected and the paper is lined up for proper vertical alignment, the operator presses the SET TOP OF FORM switch so that the internal logic will be preset to this paper length as defined by the operator.
LAXX-KW	Selective Addressing	The Selective Addressing Option allows the LA35 to operate with other terminals on a single data communications channel.
LAXX-KX	Auto Answerback and Auto LF Options	The Automatic Answerback Option allows the terminal to transmit a preprogrammed message of 20 characters (maximum). The message is initiated upon receipt of the ENQ control code from another device. The LAXX-KX may be configured to incorporate the features of the Automatic Line Feed option (LAXX-LA).
LAXX-KY	Forms Control, Vertical and Horizontal Tabs	The Forms and Tabbing option enables the printer to set horizontal and vertical tab positions via the system software. This option also incorporates features of the Top of Forms option (LAXX-KV) and operates in the same manner.

LA35 Options (Cont)

Option	Name	Description
LAXX-LG	EIA/CCITT Interface	The LAXX-LG EIA/CCITT interface provides the user with an RS232-C interface with modem control and includes a 9-ft (3.54-m) cable terminated with a standard EIA connector.
LAXX-KH	DF11 Mounting Kit	The DF11 Mounting Kit enables the user to mount one of the DIGITAL series DF11 communication options in the LA35.
LAXX-KJ	Compressed Font Option	The Compressed Font Option is a mechanical option that provides the LA35 with the ability to print 132 columns on a form 8-1/2 in. (21.59 cm) wide.
LAXX-LC	TTL TO CCITT (V28) Converter and Modem Protector	The TTL to CCITT (V28) Converter and Modem Protector is a BPO DATEL services interface that meets the requirements of CCITT (V28), with BPO-required modem protection circuitry.
LAXX-LH	Current Loop Cable	20 mA current loop with Mate-N-Lok.
LAXX-LK	Current Loop Cable	20 mA current loop with 4-pin plug for DEC10.
LAXX-KG	EIA Interface	The LAXX-LG interface includes a 9-ft (3.54-m) cable terminated with a standard EIA connector.
LAXX-LN	Scale, Pointer, and Window Kit	Operator convenience items that assist in positioning the print head on preprinted forms and for locating horizontal tabs.

LA35 DECwriter MODEL VARIATIONS

The LA35 variations and associated model numbers are listed below.

LA35-CE	90–132 V, 60 Hz
LA35-CF	180–264 V, 60 Hz
LA35-CH	90–132 V, 50 Hz
LA35-CJ	180–264 V, 50 Hz
LA35-DE	90–132 V, 60 Hz
LA35-DJ	180–264 V, 50 Hz

LA35 JUMPER CONFIGURATIONS

LA35 Optional Current Loop Configuration

The LA35 is normally configured for passive operation. To modify this configuration for active operation, jumpers on the logic board must be changed. For a

detailed description of these jumper modifications and the associated cabling required, refer to the *LA35 DECwriter Maintenance Manual*.

LA35 Parity

The LA35 is configured with no parity and no parity error printout. To modify this configuration for odd or even parity with or without error printout, jumpers on the logic board must be changed. For a detailed description of these jumper modifications, refer to the *LA35 DECwriter Maintenance Manual*.

LA35 Speaker (Bell) Volume

The LA35 can be configured for a lower speaker volume by removing a jumper. For a description of this jumper modification, refer to the *LA35 DECwriter Maintenance Manual*.

LA35 SPECIFICATIONS

Printing

Switch selectable: 10, 15, or 30 characters/second throughput

Line Length

132 characters maximum

Spacing

10 characters/in. (horizontal)
6 lines/in. (vertical)

Characters

96 upper/lower case ASCII
7 X 7 dot matrix (0.07 X 0.10 in.) (1.77 X 2.54 mm)

Paper

Variable width: 3 to 14-7/8 in. (7.62 to 37.78 cm)
Single-Part:
 15 lb paper minimum
 Card stock thickness of 0.010 in. (0.25 mm) maximum

Multipart:

2- to 6-part (see Notes)
Thickness of 0.020 in. (0.50 mm) maximum

Tractor-drive, pin-feed

NOTES

1. **Multipart forms may have only one card part. The card must be the last part.**
2. **NCR or 3M paper, up to 6-part, must use ribbon on top copy. First surface impact paper is not recommended.**
3. **Continuous-feed, fan-fold business forms with 3- or 4-prong margin crimps on both margins (multipart) are recommended. Stapled forms are not recommended and may damage tractors and other areas of the machine. Dot or line glue margins are acceptable (if line is on one margin only). Do not line glue both margins as air will not be able to escape and poor impressions will result.**

Interface

Integrated or 20 mA current loop or EIA/CCITT.

Ribbon

DIGITAL-specified nylon fabric (Part No. 36-10558)
Spool assembly: 0.5 in. (1.27 cm) wide X 40 yd (36.58 m) long

Power

90–132 Vac or 180–264 Vac
50 or 60 Hz \pm 1 Hz
300 W maximum (printing)
160 W maximum (idle)

Temperature

Operating
 10° to 40° C (50° to 104° F), noncondensing
Nonoperating
 –40° to 66° C (–40° to 151° F) noncondensing

Relative Humidity

Operating
 10 to 90% with a maximum wet bulb temperature of 28° C (82° F) and a minimum dew point of 2° C (36° F), noncondensing
Nonoperating
 5 to 95%

Dimensions

27.5 in. (69.85 cm) wide
33.5 in. (85.09 cm) high
21.7 in. (55.12 cm) deep

Weight

97 lb (44.09 kg)

LA35 OPERATOR'S GUIDE

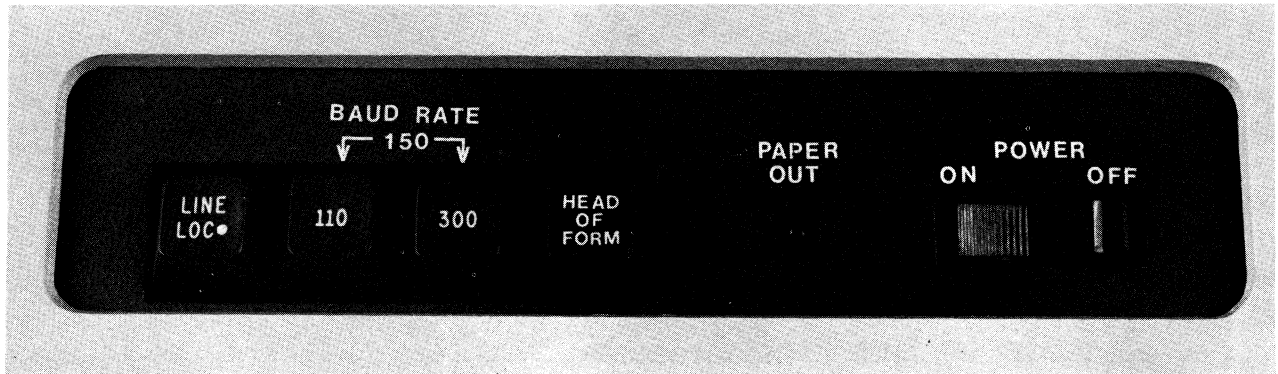

7666-22

LA35 OPERATOR CONTROLS AND INDICATORS

NOTE

Dot on switch indicates function of switch when depressed.

LINE/LOC Switch

The LINE/LOC switch is a 2-position operator control switch. When in the LINE position, the LA35 is enabled to receive data. When in the LOCAL mode, the LA35 receive line is disabled and only local operation can be performed.

BAUD RATE Switches

The BAUD RATE switches select the rate at which characters are received over the communication line.

Switch	Character Rate
110	10 (characters/second)
300	30 (characters/second)
110 and 300	15 (characters/second)

PAPER OUT Indicator

The PAPER OUT indicator, when illuminated, gives a visual indication that the LA35 is out of paper. Printing stops when the out of paper condition is detected.

POWER ON/OFF Switch

The POWER switch connects and disconnects the line voltage to the LA35 DECwriter. The POWER switch should be in the ON position for normal unit operation. When changing paper, ribbon, or adjusting the print head, the switch should be turned OFF.

HEAD OF FORM Switch

This switch is operational only when the Top of Form option is installed. Its function is to advance the paper to the head of the form.

Carriage Adjustment Lever

The Carriage Adjustment lever controls the print head gap for single-part or multipart forms.

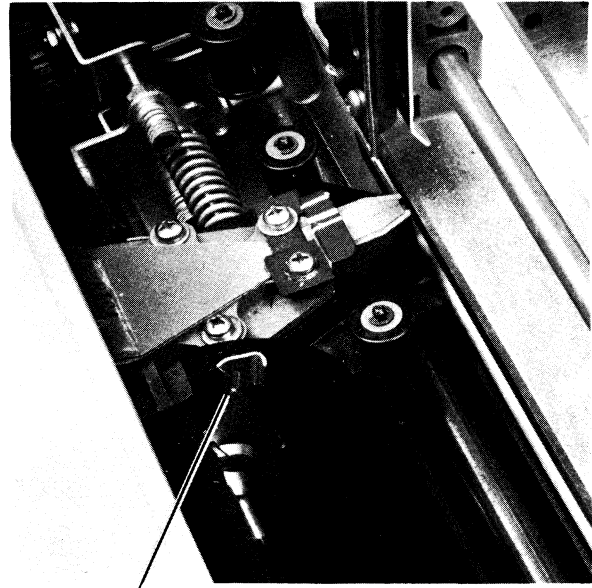

CARRIAGE
ADJUSTMENT
LEVER

7666-16

Paper Advance Knob

The Paper Advance knob pushes in to disengage the line feed gear train, allowing fine vertical adjustment of paper position. Coarse vertical adjustment is achieved by simply turning the knob. Each detent turned represents one line.

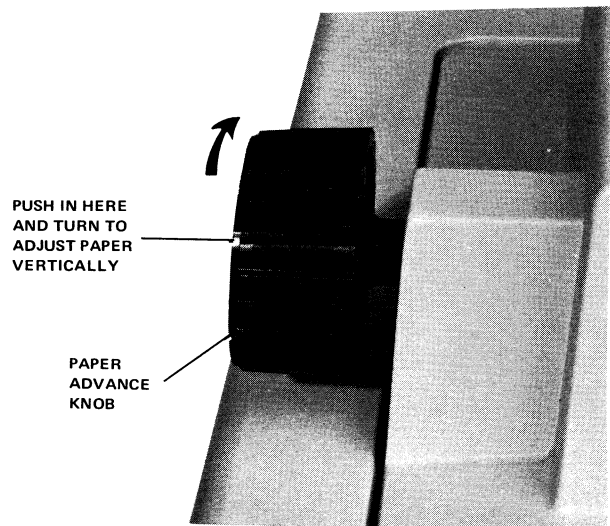

7595-4

Tractor Adjust Knob

The Tractor Adjust knob allows fine horizontal adjustment of forms.

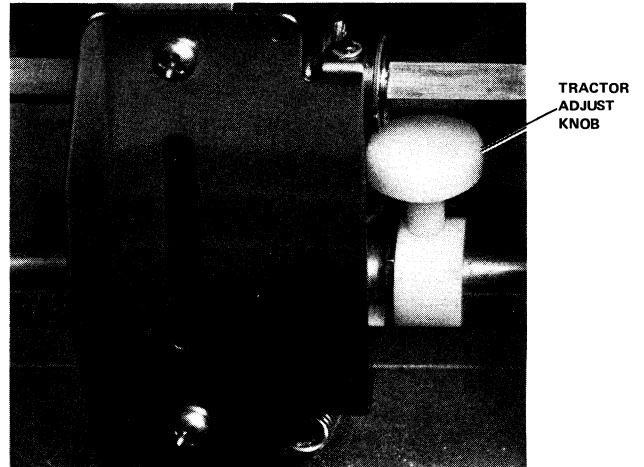

7595-7

Bell

The bell indicates that a bell code was received.

USING THE LA35

Using the LA35 requires almost no operator intervention. These few steps are all that may be required to place the LA35 on-line.

1. Load paper.

2. Set the LINE/LOC switch to LINE.

3. Set the BAUD RATE switches to the applicable baud rate.

4. Set the POWER switch to ON.

The LA35 is now on-line and fully operational.

LA35 INSTALLATION AND CHECKOUT GUIDE

GENERAL INSTALLATION INFORMATION

This section contains the step-by-step procedures for unpacking and unit checkout to ensure that the unit was not damaged during shipment and that the unit is operating properly prior to connection to the communication system.

The LA35 DECwriter should be installed in an area that is free of excessive dust, dirt, corrosive fumes, and vapors. To ensure that the unit has proper ventilation and cooling, the ventilation openings on the side of the cabinet should not be obstructed. A minimum 4-in. clearance between units must be maintained at all times. Adequate service clearance must also be provided for servicing the unit. (Refer to the figure on the following page.)

UNPACKING AND REPACKING

Unpack the LA35 as described in Section 3. If it becomes necessary to ship the LA35 to another site, refer to the repacking procedure described in Section 3.

CHECKOUT AND ACCEPTANCE PROCEDURES

Perform the following procedure. If the desired results are not achieved, refer to the troubleshooting guide in Section 3.

1. Install ribbon per ribbon installation procedure (Section 3).
2. Install paper per paper loading procedure (Section 3).

CAUTION

Before connecting the LA35 to a power source, ensure that the line voltage and frequency are compatible with the power requirements of the machine. Ensure that the POWER switch on the console is OFF.

3. Connect the LA35 line cord to the correct wall receptacle; press the control panel POWER switch on the ON position. The print head automatically positions itself to the left margin.
4. Set the BAUD RATE switches to the applicable baud rate.
5. Set the LINE/LOC switch to LINE.
6. Run the applicable software and observe printout for the desired results.

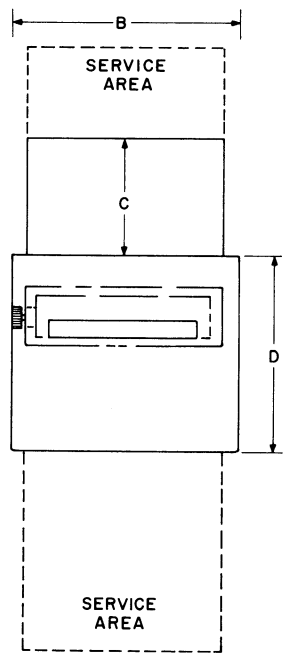
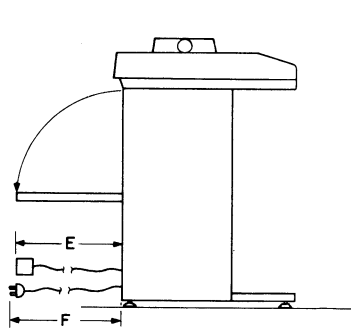
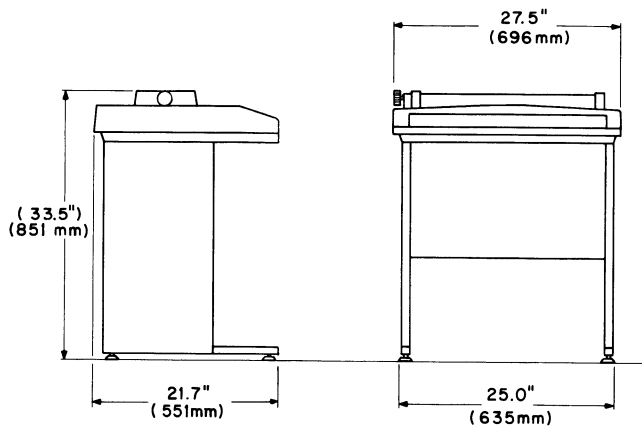

DIMENSIONS	A	B	C	D	E	F
INCHES		27.5	14	21.7	V*	96
MILLIMETERS		696	356	551	V*	2440

* CURRENT LOOP CABLE (BC05F) LENGTH IS 15 FT ; E1A CABLE LENGTH IS 9FT (2744mm)

CP-2021

LA35 Site Considerations

CONTROLS AND INDICATORS FOR LA35 OPTIONS

The following options include additional controls not present on basic LA35 DECwriters.

FORMS CONTROL OPTION (LAXX-KV)

This option requires the addition of a top-of-form control assembly, which is installed beneath the top cover on the print head chassis. There are two controls on this assembly: SET TOP OF FORM and FORM LENGTH (Figure 27).

- *SET TOP OF FORM* is a pushbutton that clears the previously loaded form length and loads the current setting of the FORM LENGTH switch.
- *FORM LENGTH* is a 12-position rotary switch that is used to preset a form length (in inches) into the Forms Control.

FORMS CONTROL, VERTICAL TABULATION, AND HORIZONTAL TABULATION OPTION (LAXX-KY)

This option also utilizes the top-of-form control assembly (Figure 27).

SCALE, POINTER, AND WINDOW OPTION (LAXX-LN)

This option contains three indicators: Column Scale, Line Indicator, and Column Pointer as shown in Figure 28.

- The *column scale* is a 17.25-in. long strip that is marked off in 132 divisions representing the possible column locations. The column scale adheres to the plastic print window.
- The *line indicator* mounts on the print head and is used to establish two printing locations. The longer top surface indicates the baseline of the characters in a particular line. When setting up a form or rolling back to a previously printed line, this top surface is used to exactly align where the next character will print. The smaller surface on the right side indicates the position where the next character will print. This position is valid only *after* the Last Character Visibility shift. The line indicator is also included in the APL/ASCII Dual Character Set Option (LAXX-PK).

- The *column indicator* is used in conjunction with the column scale. There are red and green indicator lines on the column indicator to indicate the next column to be printed. The green line is used *before* the Last Character Visibility shift, the red line *after* the shift.

ACOUSTICAL COUPLER OPTION (LAXX-LM)

There is a single indicator associated with this option. This red indicator is mounted on the right side of the cover and lights when the telephone handset is properly inserted in the muff assembly and a carrier is detected by the coupler circuitry.

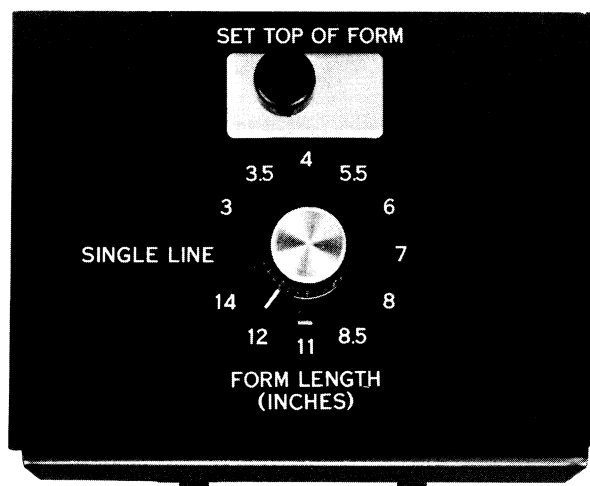

7622-4

Figure 27 Forms Control Assembly

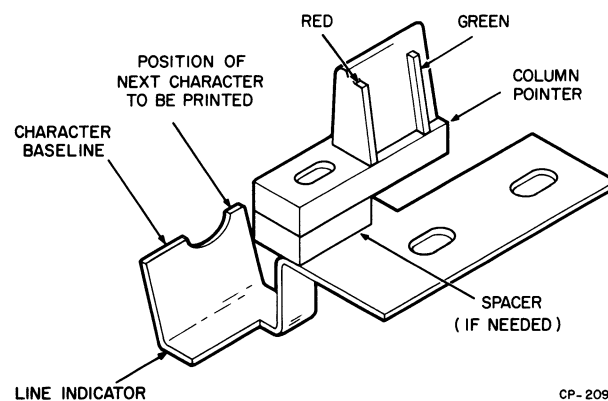

CP-2099

Figure 28 Line Indicator and Column Pointer

SETUP AND OPERATING PROCEDURES FOR LA35 OPTIONS

LA35 options requiring setup or operating instructions in addition to those instructions given for the basic LA35 are presented in the following paragraphs.

APL OPTION (LAXX-PK)

An LA36 DECwriter containing this option can print either the standard ASCII characters or the alternate APL characters. Character set switching is controlled by either a Switch In or Switch Out command. Switch In (code 016g) selects the standard ASCII character set; Switch Out (code 017g) selects the alternate APL set.

Figure 29 shows the bit assignments for both character sets.

FORMS CONTROL OPTION (LAXX-KV)

Setup — (The DECwriter is assumed to be deenergized.) Measure the form to determine its length in inches. Then remove the top cover from the LA36 as in the paper loading procedures. On the Forms Control panel, set the FORM LENGTH rotary switch to the number that corresponds, in inches, to the length of the form (Table 3). Proceed with the normal loading of the forms. When completed, use the Paper Advance knob to align the top line of the form with the print head. (Normally the top line is 2 or 3 lines below the perforation, but it can be established at any line on the form.) Close the top cover and energize the DECwriter. The form length indicated by the FORM LENGTH switch is automatically entered during the power-up sequence.

The procedure for setting up the Forms Control Option when the DECwriter is energized is the same except that the SET TOP OF FORM pushbutton has to be pressed after the form length is selected.

Operation — The program-generated Form Feed (FF) command is 014g. Upon receipt of a Form Feed command, the paper will advance to the next top-of-form line.

FORM CONTROL PROGRAMMING NOTES

1. To avoid losing incoming characters during a form control operation, fill characters must be added. These nonprinting fill characters (such as NULL or DELETE) effectively slow up the data input rate

while the printer mechanism is positioning the form. The best way to determine the required number of these fill characters is to count the number of lines from the last line printed to the bottom of the form and insert this number of fill characters. In character combinations when the character buffer is empty prior to a carriage return, 15 fill characters can be subtracted from the above number. All fill calculations are made at 300 baud. For 150 baud, halve the values (round off to the next higher number); for 110 baud, use one third (round off to the next higher number).

2. Once a form feed has begun, it cannot be aborted. If a second Form Feed command is issued within 16 lines from the next top of form, the paper will not stop at that next top of form, but will execute the second Form Feed command and skip one full form length. If the second Form Feed command is issued with 17 or more lines remaining to the bottom of the present form, it will be ignored. Like-wise, more than two Form Feed commands within one form interval will not be recognized.

Table 3
FORM LENGTH Switch Positioning

Form Length (inches)	FORM LENGTH Switch Setting	Printable Lines Per Form (Maximum)
3	3	18
3.5	3.5	21
4	4	24
5.5	5.5	33
6	6	36
7	7	42
8	8	48
8.5	8.5	51
11	11	66
12	12	72
14	14	84

FORMS CONTROL, VERTICAL TABULATION, AND HORIZONTAL TABULATION OPTION (LAXX-KY)

Setup — This option requires three setup procedures.

Bits					0	0	0	0	1	1	1	1
					0	0	1	1	0	0	1	1
					0	1	0	1	0	1	0	1
b ₇	b ₆	b ₅	Column		0	1	2	3	4	5	6	7
b ₄	b ₃	b ₂	b ₁	Row	0	1	2	3	4	5	6	7
0	0	0	0	0	NUL	DLE	SP	0	@	P	`	Ɔ
0	0	0	1	1	SOH	DC1	!	1	A	Q	a	q
0	0	1	0	2	STX	DC2	"	2	B	R	b	r
0	0	1	1	3	ETX	DC3	#	3	C	S	c	s
0	1	0	0	4	EOT	DC4	\$	4	D	T	d	t
0	1	0	1	5	ENQ	NAK	%	5	E	U	e	u
0	1	1	0	6	ACK	SYN	&	6	F	V	f	v
0	1	1	1	7	BEL	ETB	'	7	G	W	g	w
1	0	0	0	8	BS	CAN	(8	H	X	h	x
1	0	0	1	9	HT	EM)	9	I	Y	i	y
1	0	1	0	10	LF	SUB	*	:	J	Z	j	z
1	0	1	1	11	VT	ESC	+	;	K	[k	{
1	1	0	0	12	FF	FS	,	<	L	\	l	
1	1	0	1	13	CR	GS	-	=	M]	m	}
1	1	1	0	14	SO	RS	.	>	N	^	n	~
1	1	1	1	15	SI	US	/	?	O	_	o	DEL

a. Standard (ASCII) Character Set

Bits					0	0	0	0	1	1	1	1
					0	0	1	1	0	0	1	1
					0	1	0	1	0	1	0	1
b ₇	b ₆	b ₅	Column		0	1	2	3	4	5	6	7
b ₄	b ₃	b ₂	b ₁	Row	0	1	2	3	4	5	6	7
0	0	0	0	0	NUL	DLE	SP	0	-	*	◊	Ɔ
0	0	0	1	1	SOH	DC1	~	1	α	?	A	q
0	0	1	0	2	STX	DC2)	2	⊥	Ɔ	B	R
0	0	1	1	3	ETX	DC3	<	3	n	Γ	C	S
0	1	0	0	4	EOT	DC4	⊥	4	L	~	D	T
0	1	0	1	5	ENQ	NAK	=	5	ε	↓	E	U
0	1	1	0	6	ACK	SYN	>	6	-	u	F	v
0	1	1	1	7	BEL	ETB	⌋	7	∇	ω	G	w
1	0	0	0	8	BS	CAN	v	8	Δ	⊃	H	x
1	0	0	1	9	HT	EM	^	9	l	↑	I	y
1	0	1	0	10	LF	SUB	≠	<	o	c	J	z
1	0	1	1	11	VT	ESC	÷	⌈	'	←	K	{
1	1	0	0	12	FF	FS	,	‡	□	†	L	
1	1	0	1	13	CR	GS	+	x	l	→	M	}
1	1	1	0	14	SO	RS	.	‡	τ	⊥	N	\$
1	1	1	1	15	SI	US	/	\	θ	-	o	DEL

b. Alternate (APL) Character Set

Figure 29 Bit Assignments for ASCII and APL Character Sets

Forms Control Setup – Exactly the same as in the Forms Control Option (LAXX-KV).

Vertical Tabulation Setup – First perform the Forms Control setup and, after establishing the top-of-form position, issue Line Feed commands (012_g) to move the form to the desired location of the first vertical tab. To store this line count, issue 033_g and 063_g. Advance the form to the next vertical tab and store this location in the same manner. The number of tabs that can be set is limited by the number of printable lines on the form used. For example, an 11-in. deep form could have up to 66 vertical tabs.

To clear all vertical tabs, issue codes 033_g and 064_g. All tabs are cancelled (cleared) during a power-up sequence.

VERTICAL TABULATION PROGRAMMING NOTES

1. Similar to the form feeding sequence, the vertical tabulation action requires fill characters to slow up the input data while the mechanism is advancing the form. Use the same rule as before to determine the number of fill characters.
2. If a Vertical Tab command (013_g) is issued and there are no tab locations set, the LA35 will perform a form feed (FF) and advance the paper to the next top-of-form location.
3. Once a vertical tab has begun, it cannot be aborted. If a second Vertical Tab command is issued within 16 lines from the next vertical tab stopping position, the paper will not stop at that next position, but will advance to the second vertical tab location. If a second Vertical Tab command is issued with 17 or more lines remaining in the present advance, it will be ignored. Likewise, more than two Vertical Tab commands within one tab interval will not be recognized.

Horizontal Tabulation Setup – Before setting horizontal tabs, issue a carriage return (code 015_g). This ensures that the print head starts at the left margin. Issue space characters (by code 040_g) until the print head is positioned at the desired horizontal tab location. To store this location, issue codes 033_g then 061_g.

Then space the print head to the next desired tab location and store this location in the same manner. The number of horizontal tabs that can be set is limited by the available number of print columns on the form. For example, a 17-in. wide form can have up to 132 tabs. Command 011_g will initiate a horizontal tab move. To clear all horizontal tabs, issue codes 033_g, then 062_g. All horizontal tabs are cancelled (cleared) during a power-up sequence.

HORIZONTAL TABULATION PROGRAMMING NOTES

1. To ensure against loss of data while the printer mechanism is executing horizontal tabs, fill characters are used to effectively slow up incoming data. The number required is determined by multiplying the number of spaces between tabs by 0.55 (round off to the next higher number) or 12, whichever is greater. The 12 fill characters are needed to compensate for the maximum carriage return time. In instances where the tab does not follow a carriage return, only 0.55 times the number of spaces are needed for fills. All fill calculations are made at 300 baud. For 150 baud, halve the value (round off to the next higher number); for 110 baud, use one third (round off to the next higher number).
2. If a Horizontal Tab command is received and there are no tab locations set, the print head will advance to column 132 and remain there until a carriage return is received.
3. Once a horizontal tab has begun, it cannot be aborted. If a second Horizontal Tab command is issued within 16 spaces from the next horizontal tab stopping position, the head will not stop at that next position, but will advance to the second horizontal tab location. If a second Horizontal Tab command is issued with 17 or more spaces remaining in the present advance, it will be ignored. Likewise, more than two Horizontal Tab commands within one tab interval will not be recognized.

AUTOMATIC LINE FEED OPTION (LAXX-LA)

The Auto Line Feed action is controlled by the presence of jumper W1 on the auto line feed assembly circuit board. Table 4 shows the various conditions that produce the specified number of line feeds.

When W1 is not cut out, the DECwriter will automatically insert a Line Feed command after each Carriage Return command received. This is a convenience for existing programs that do not normally have a Line Feed after a Carriage Return command. To disable this automatic insertion of the Line Feed command, cut jumper W1 located on the Automatic Line Feed Option circuit board.

**Table 4
Auto Line Feed Setup**

Jumper W1 In or Out	Initiating Action	Number of Line Feeds Produced
In	Receive CR with LF	2
	Receive CR without LF	1
Out	Receive CR with LF	1
	Receive CR without LF	0

**AUTOMATIC LINE FEED PROGRAMMING
NOTES**

1. If jumper W1 is not cut and the received program already transmits a line feed after each carriage return, a second line feed action will be performed by the printer.
2. With jumper W1 inserted, a nonprinting, non-spacing fill character must be sent after each carriage return. An idle (marking) line time of one character is required after each carriage return to ensure no loss of data during the mechanical action of the printer.

AUTOMATIC ANSWERBACK OPTION (LAXX-KX)

The Auto Answerback Option provides for up to 20 programmable character locations. This stored message is transmitted when an ENQ (005g) command is received.

The message is stored in twenty 7-bit slide switches located on the Auto Answerback board as shown in Figure 30. The 7-bit ASCII code for the letter "a" is also shown. Slide switch No. 1 corresponds to b1 and the ON position corresponds to an asserted (high) logic state.

Any legitimate ASCII character can be included in the answerback message, including commands, alpha, or numeric characters.

NOTES

1. Spaces are counted as characters.
2. Messages shorter than 20 characters can be terminated by making the last character a NUL (0000000). All remaining characters are disregarded. A full 20-character message does not require a NUL at the end.

The Automatic Answerback Option also contains the operational features of the Automatic Line Feed Option (LAXX-LA). The Auto Answerback circuit board contains two factory-installed jumpers that can be cut out to eliminate certain operations of the auto line feed function. The possible jumper configurations are:

Jumpers		Action Add LF to Received CR
W1	W3	
In	N/A	Yes
Out	N/A	No

SELECTIVE ADDRESSING OPTION KIT (LAXX-KW)

The Selective Addressing Option has two 7-bit DIP switches mounted on the logic board as shown in Figure 31. One switch establishes the unique address code; the other the group address. These codes are entered by positioning the seven slide switches as shown in the example of Figure 31.

Under the 7-bit code, a practical limit of 123 devices may be interrogated, since the selection command codes (CTRL D, CTRL E, CTRL B, CTRL C, and CTRL F) should not be used as addresses. However, it may be advisable to set the limit to 96 devices, as the 32 ASCII control codes may cause other undesired systems operation. When group selecting, there is no limit to the number of terminals that may be in the group.

The inherent receive-only characteristic of an LA35 establishes the terminal as a slave when connected into a multipoint communications network. There are three possible slave states as follows:

- Broadcast Slave — A condition that allows all terminals in the network to receive data transmitted by the master.

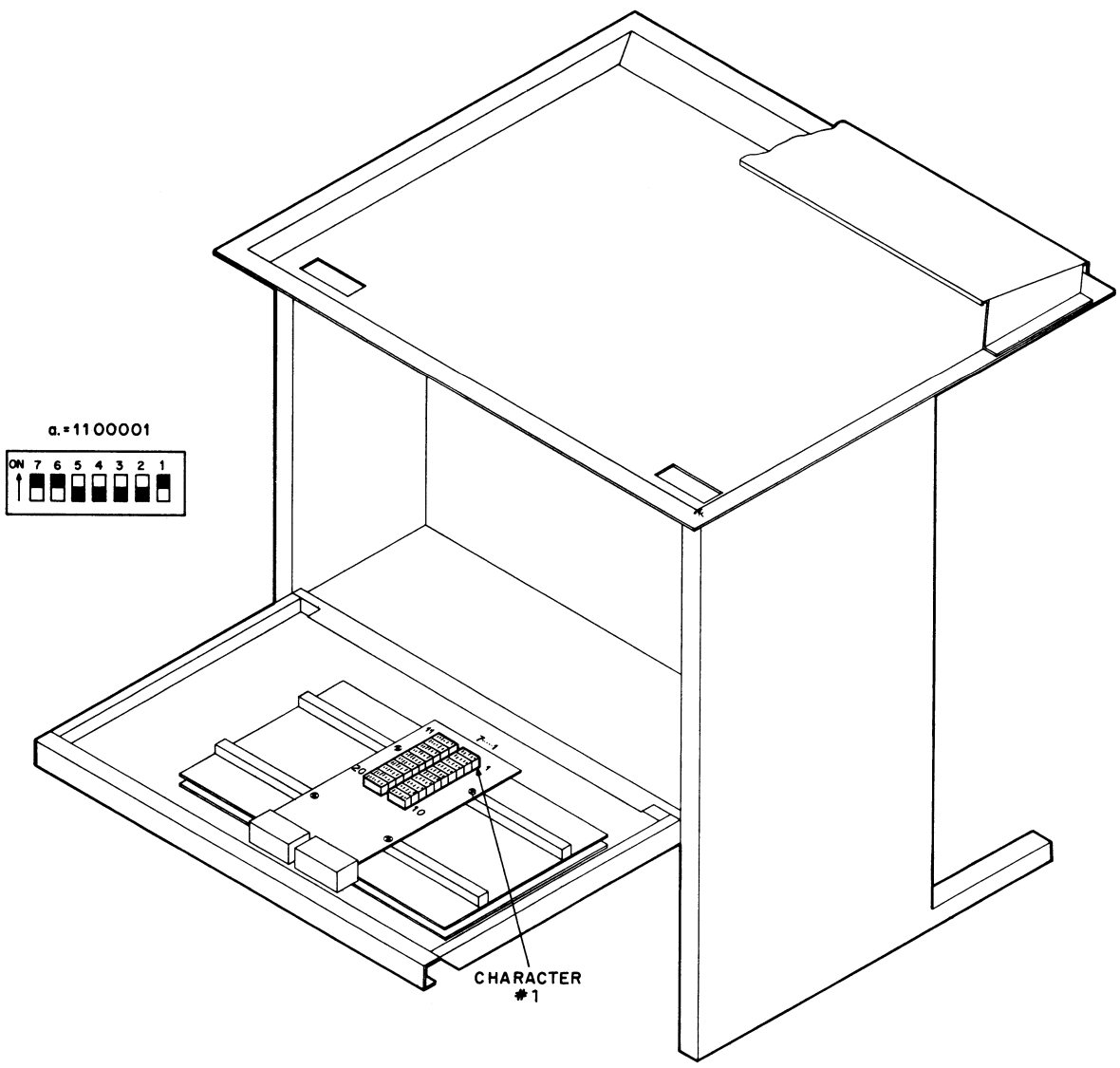

CP-2101

Figure 30 Location of 20 Answerback Message Characters

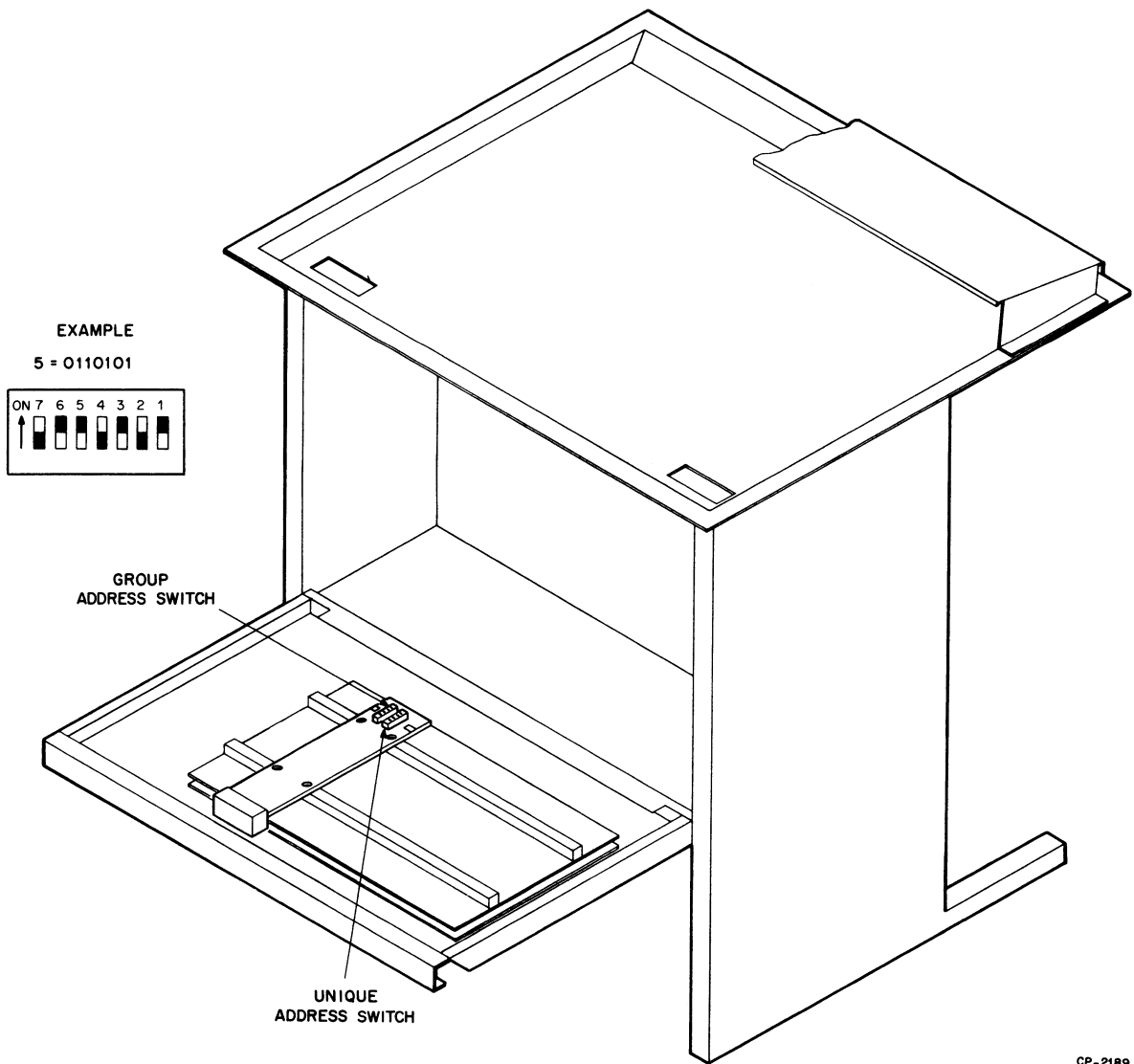

Figure 31 Location of Address Setting Switches

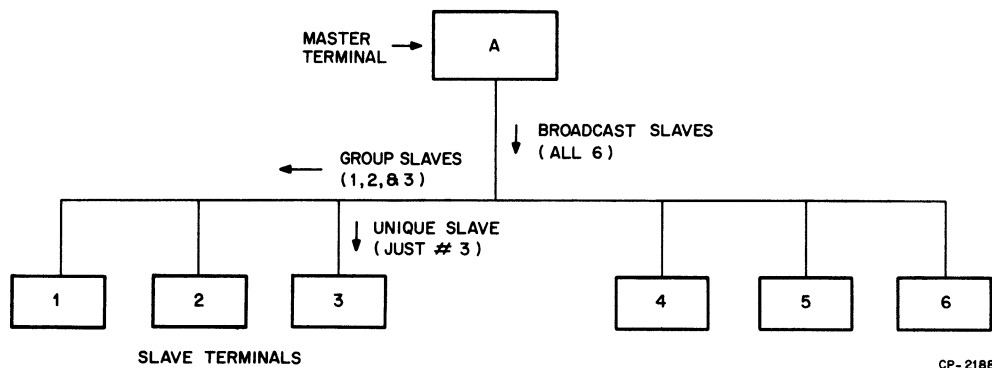

Figure 32 Typical Selective Addressing Communications Network

- **Group Select Slave** – When addressed by the master using the group address entered into the Group Select switch on the option board, a particular group of terminals can receive data sent by the master. Terminals not having this particular group address do not receive data even though they are within the same communications network.
- **Unique Select Slave** – Each terminal can have a unique address which is different from its group address code. When addressed using this unique code by a master, it is possible to establish communications between these two terminals and no other terminals in the network.

Figure 32 depicts a communications network of seven terminals. It is assumed that terminal A is the master and the other six are slaves, each with a unique address; terminals 1, 2, and 3 have the same group address while 4, 5, and 6 have a different group address. When the master (A) transmits in broadcast, all terminals print the transmission. When the master addresses the three having the same group address, only these three receive the transmitted data. The master can also use the unique address of one of the six to establish communication while the other five disregard all transmission between these two. In addition, the master can address multiple unique addresses to form other groups (i.e., terminals 1, 3, and 6 can be grouped to receive the same data if the master sequentially addresses these terminals).

Slave terminals operate in either the address mode or data mode. In the address mode, terminals respond to character combinations that make up their broadcast, unique, or group addresses. In the data mode,

they do not acknowledge their addresses, even though the address is present on the communications line. The master terminal establishes whether the slave terminals are in one mode or the other.

The following six commands are generated at the master terminal and control the operation of the slave terminals in the communications network.

1. **000g (NUL)** – Used to reset all slave terminals to their address mode. This action occurs before the master sends addresses down the line.
2. **003g (ETX)** – Upon receiving 003g, all slave terminals switch from the data mode to the address mode and terminal selection can take place. This allows a master to select additional devices without having to surrender the lines or having to readdress previously selected stations. To continue addressing additional terminals, the normal selection rules apply, with the sequence terminating with 002g to lock all devices into either the selected or unselected mode.
3. **006g (BELL)** – Used to select all terminals to receive simultaneously (broadcast mode). Until a code 002g has been received, the BELL code does not cause the bell on the printer to sound.
4. **002g (STX)** – Used to “lock” all terminals in their selected or unselected mode and to prevent an unintentional selection during data transmission. No terminal begins to print until 002g is received.

5. 005_g (ENQ) – Only used with uniquely selected slave terminals (has no effect on broadcast and group selected slaves). When a uniquely selected slave terminal has an Auto Answerback Option (LAXX-KX) installed and receives a 005_g, the stored answerback message is sent back to the master terminal. This allows verification that the correct slave terminal is being addressed. The answerback message is transmitted after the EIA interface CLEAR TO SEND signal goes high.
6. 004_g (EOT) – Used to reset all terminals on the line so that none are selected.

The master establishes the type of slave as follows:

Broadcast

- Issue 007_g.
- Issue 002_g.
- Send message – All terminals receive 004_g at the end of a message.

Group

- Type group address.
- Issue 002_g.
- Send message – all terminals in group receive 004_g at the end of a message.

Unique Select

- Type unique address.
- Issue 005_g.
- Type any character.
- Issue 002_g.
- Send message – Addressed terminal receives 004_g at the end of a message.

Select (add-on)

To add other terminals to terminals already selected without having to readdress all terminals, perform the following:

- Issue 003_g.
- Type new address or addresses.
- Issue 002_g.
- Send message – 004_g at the end of a message.

ACOUSTICAL COUPLER OPTION (LAXX-LM)

Setup – The following conditions must be met before using the acoustical coupler. printer power ON, on-line, baud rate matched to sending system. Call the number of the sending system and listen for the carrier sound (loud whistle). After receipt of carrier, place the handset into the acoustical coupler muff assembly with the phone cord end of the handset inserted into the muff with the "dot" and/or word "CORD" next to it. Within 5 seconds, the carrier light illuminates. Normal system operation may now commence.

NOTE

Before removing the telephone handset from the muff assembly, place the DECwriter in the local mode. This action prevents the disconnect noise from causing printing of random characters.

INSTALLATION AND CHECKOUT OF LA35 OPTION KITS

INTRODUCTION

Figure 33 contains three basic cabling diagrams for the LA35. These diagrams depict the cabling configurations between the M7728 logic board and the Expander Mounting Option (LAXX-LB) for the various option kits available. Before installing any option, it is recommended that these diagrams be consulted to ensure proper cabling.

EXPANDER OPTION MOUNTING KIT (LAXX-LB)

The Expander Option Mounting Kit contains the following:

Quantity	Item	Part Number
1	Option Distribution Board Assembly	D-CS-5411668-0-1
1	Right-Hand Side Rail Assembly	D-MD-7414045-0-0
1	Left-Hand Side Rail Assembly	D-MD-7414044-0-0
4	Grommets	9007017-00
2	Interconnecting Cables	C-IA-BC08S-1B
1	+5 Volt Power Cable	C-IA-7010001-8

A nut driver, Phillips, and straight blade screwdrivers are required to install the Expander Option Mounting Kit. Use Figures 33 and 34 and the following procedures as installation guides.

1. Unplug the ac power cord.
2. Unhook all cables from the logic board.
3. Remove the six screws and washers that secure the logic board to the cabinet door and then remove the logic board.
4. Place the right and left side brackets (1, Figure 34), over the screw studs as shown. The hinge tabs of the side brackets (2) should be point inward toward each other and toward the interior of the cabinet.
5. Place a grommet (3) over each stud that sticks up through the brackets.
6. Carefully replace the logic board on top of the grommets and secure with the six screws and associated washers previously removed.
7. On the option distribution board assembly (Figure 34), remove screw (4) and loosen screw (5) on each hinge bracket.
8. Squeeze each hinge bracket toward the middle until the hinge tabs (2) of the side brackets can be inserted into the pivot holes as shown.
9. Insert the two screws (4) and tighten these screws and screws (5).
10. Lock both ¼turn fasteners (6) to secure the option distribution board assembly to the side rails.
11. Connect the interface cables as shown in Figure 33, depending upon the options being installed.
12. Reconnect the +5V supply cable (black and red wires) to the logic board. Connect one end of a similar cable (supplied with this option) to the +5 and GND terminals or the power board and the other cable end to the Faston terminals (7, Figure 34) on the option distribution board assembly. Route the cable with existing cables to the power board.

CAUTION

The ribbon cables between the logic board and the expander board must be installed so that one cable end has the ribbed side of the cable facing up and the other end has the smooth side up. Ensure that A connects to A at each cable end. Failure to observe this polarity may cause a logic board failure.

Test After Installation — Energize the DECwriter. In the on-line mode, data sent will produce printed characters.

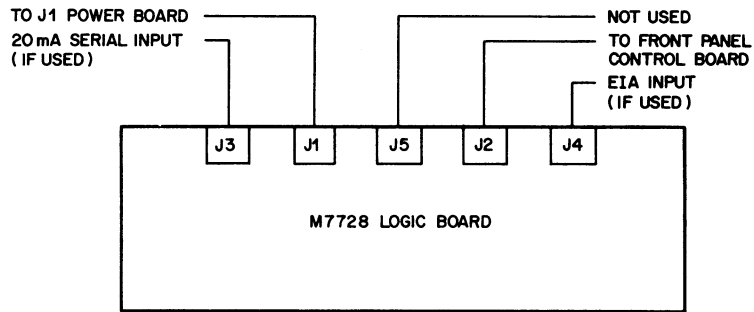

A. No options installed

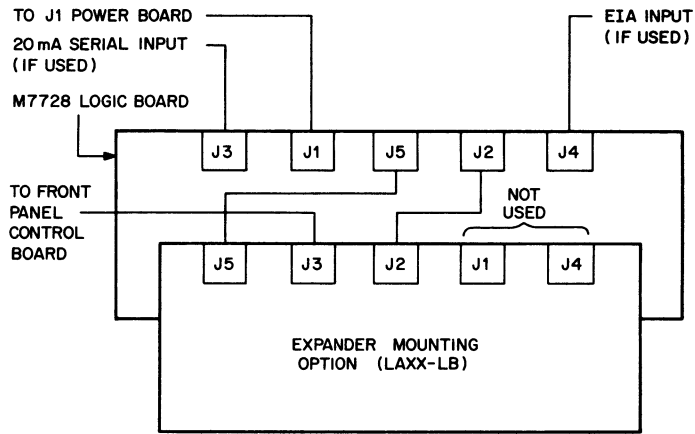

B. Any option and auto line feed or auto answerback options *not* installed

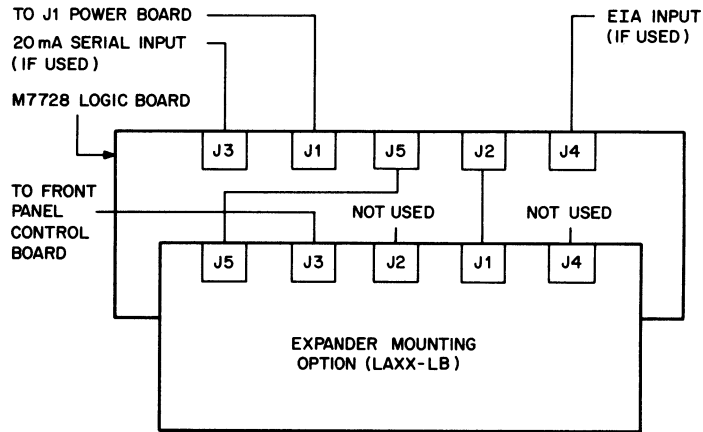

C. Any option and auto line feed or auto answerback options installed.

CP-2191

Figure 33 Cabling Configurations for Various LA35 Options

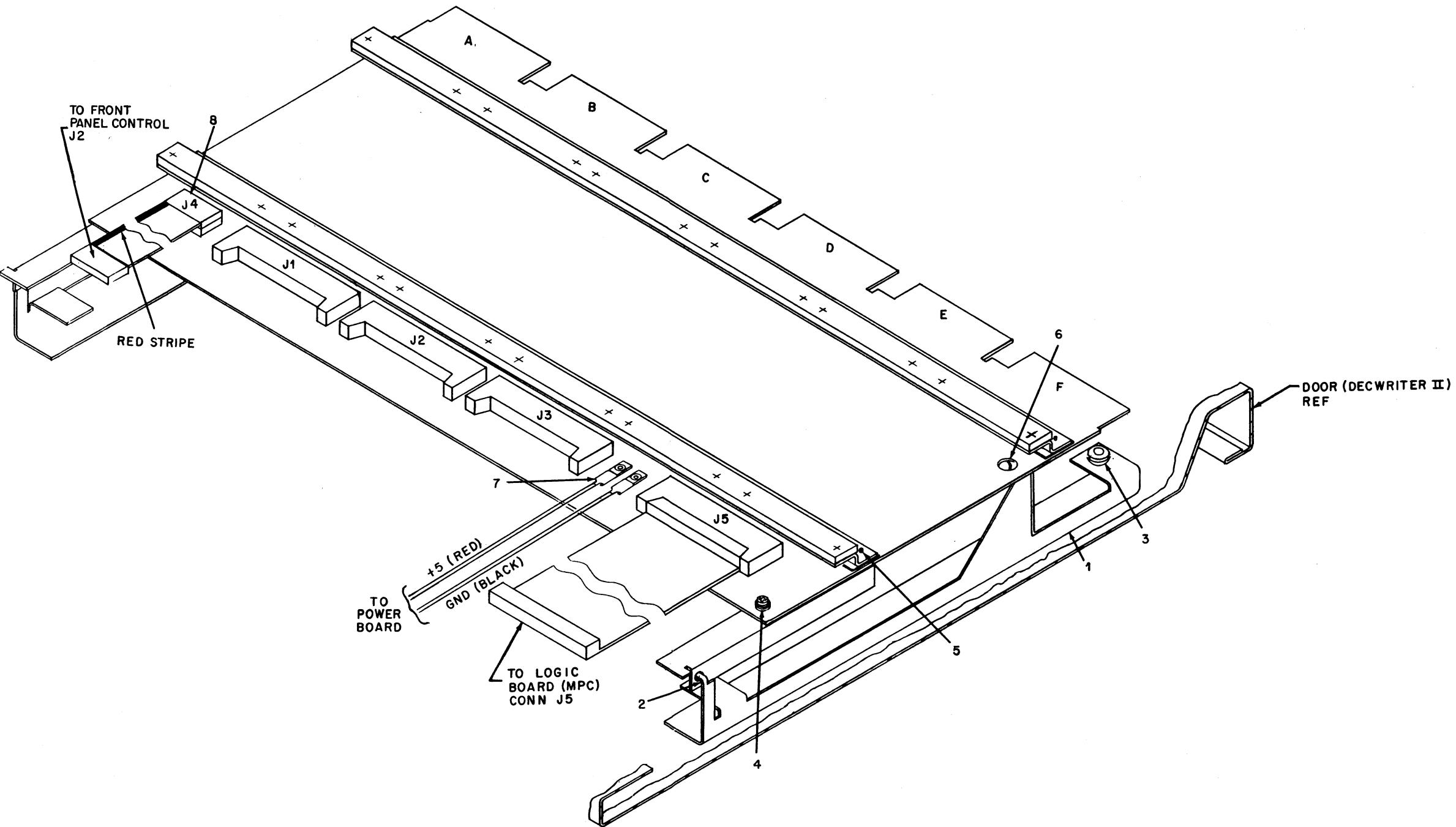

CP-2104

Figure 34 Installation of Expander Mounting Kit (LAXX-LB)

APL OPTION KIT (LAXX-PK)

The APL Option Kit contains the following:

Quantity	Item	Part Number
1	APL/ASCII Dual Character Set Board	D-CS-M7732-0-1
1	Edge Connector	B-UA-H851-0-0
1	APL ROM	23086A6
1	APL ROM	23087A6
4	Phillips Pan Head Screws (#34-40 X 0.38 in.)	9006011-1
4	Flat Washers (#4)	9006655
4	Lock Washers (#4)	9006688
1	Line Indicator	C-MD-7414953-0-0

A Phillips screwdriver and a 11/32-in. nut driver are required tools for installation. Use Figure 35 and the following procedure as installation guides.

NOTE

Unplug the DECwriter and remove paper.

1. If not already installed, install the Expander Option Mounting Kit (LAXX-LB).
2. Refer to Figure 33 for the correct interface cabling required to integrate the APL Option into the existing options.
3. Using the supplied hardware (1) (four #4-40 X 0.38-in. screws and #4 washers), secure the APL board in location F on the expander board (Figure 35).
4. Install the H851 edge connector (2). (Edge connector and board are keyed for proper fit.)
5. Insert the two APL ROMs: No. 23087A6 in socket (3) and No. 23086A6 in (4). Refer to Figure 35 for Pin No. 1 locations.
6. Remove the cover from the DECwriter.
7. Remove the two front screws (5) and associated washers from the print head, install the line indicator (6) as shown, and reassemble the removed hardware.
8. Replace the cover.

Test After Installation — Install paper and apply power. In the line mode, the DECwriter will print APL characters when program selected.

FORMS CONTROL OPTION KIT (LAXX-KV)

The Forms Control Option Kit contains the following:

Quantity	Item	Part Number
1	Top-of-Form Control Assembly Board	D-AD-7011503-0-0
1	Top-of-Form Module Board	D-CS-M7735-0-1
1	Top-of-Form Cable	D-IA-7011516-0-0
4	Phillips Pan Head Screws (#4-40 X 3/8 in.)	9006011-1
4	Phillips Pan Head Screws (#6-32 X 3/8 in.)	9006022-1
1	Edge Connector	B-UA-H851-0-0
4	Lock Washers (#4)	9006688
6	Lock Washers (#6)	9007801
4	Flat Washers (#4)	9006655
4	Flat Washers (#6)	9006653

A Phillips screwdriver is the only tool required for installation. Use Figure 36 and the following procedure as installation guides.

1. Unplug the ac power cord and open the top cover.
2. If not already installed, install the Expander Option Mounting Kit (LAXX-LB).
3. Refer to Figure 33 for the correct interface cabling required to integrate the Forms Option into the existing options.
4. Unscrew the attaching hardware of the bell speaker. Save the two #6 flat washers and two #6-32 X 3/8-in. screws but discard the Kep nuts.
5. Remove and save the bracket hardware (2) (#8-32 X 3/8-in. screw, #8 lock washer, #8 flat washer).
6. Attach the speaker to the inside of the top-of-form control assembly (1). Use four #6-32 X 3/8 in. screws, #6 flat and lock washers and secure from the inside as in (4).

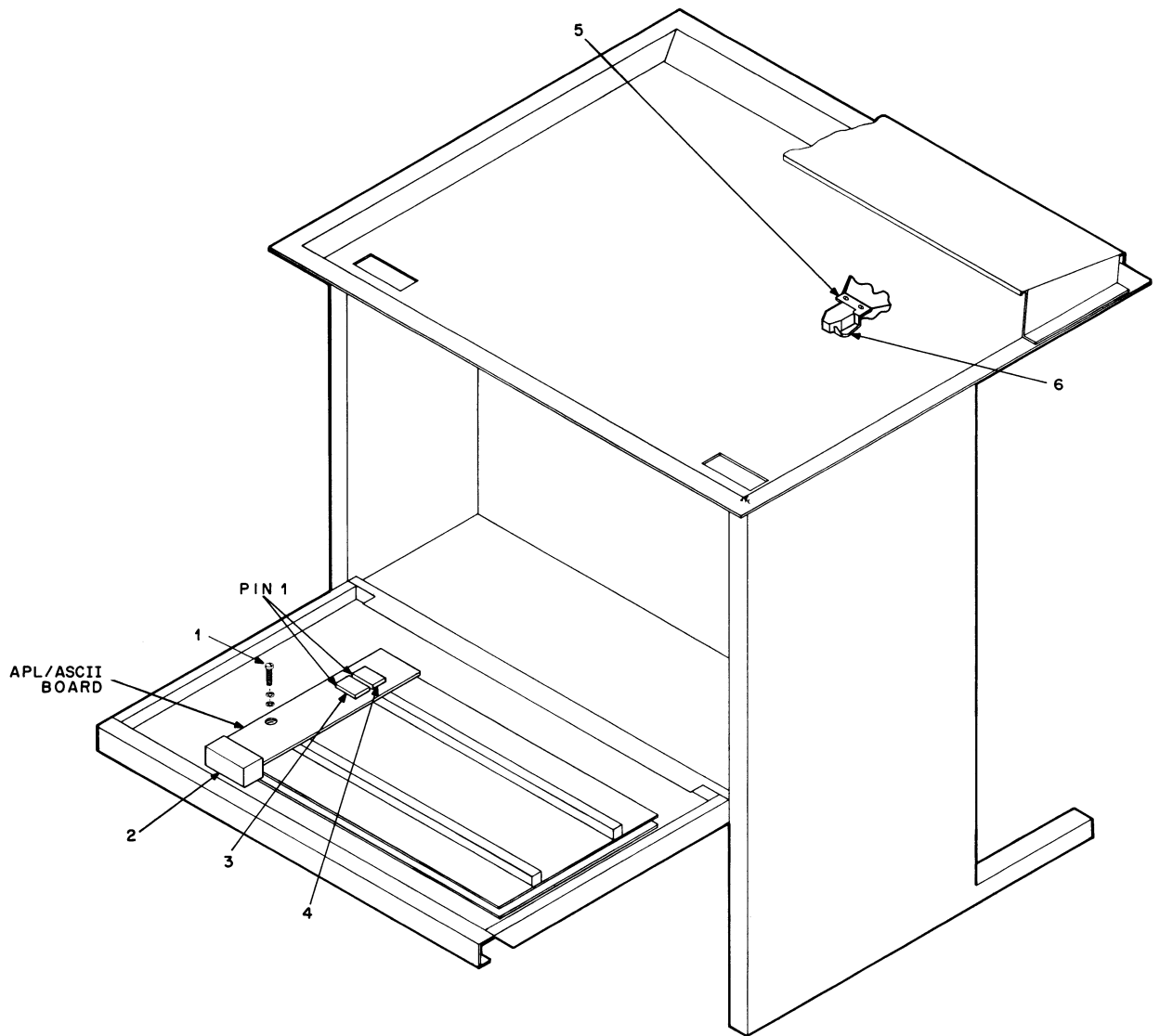

CP - 2105

Figure 35 Installation of the APL/ASCII Dual Character Set Board

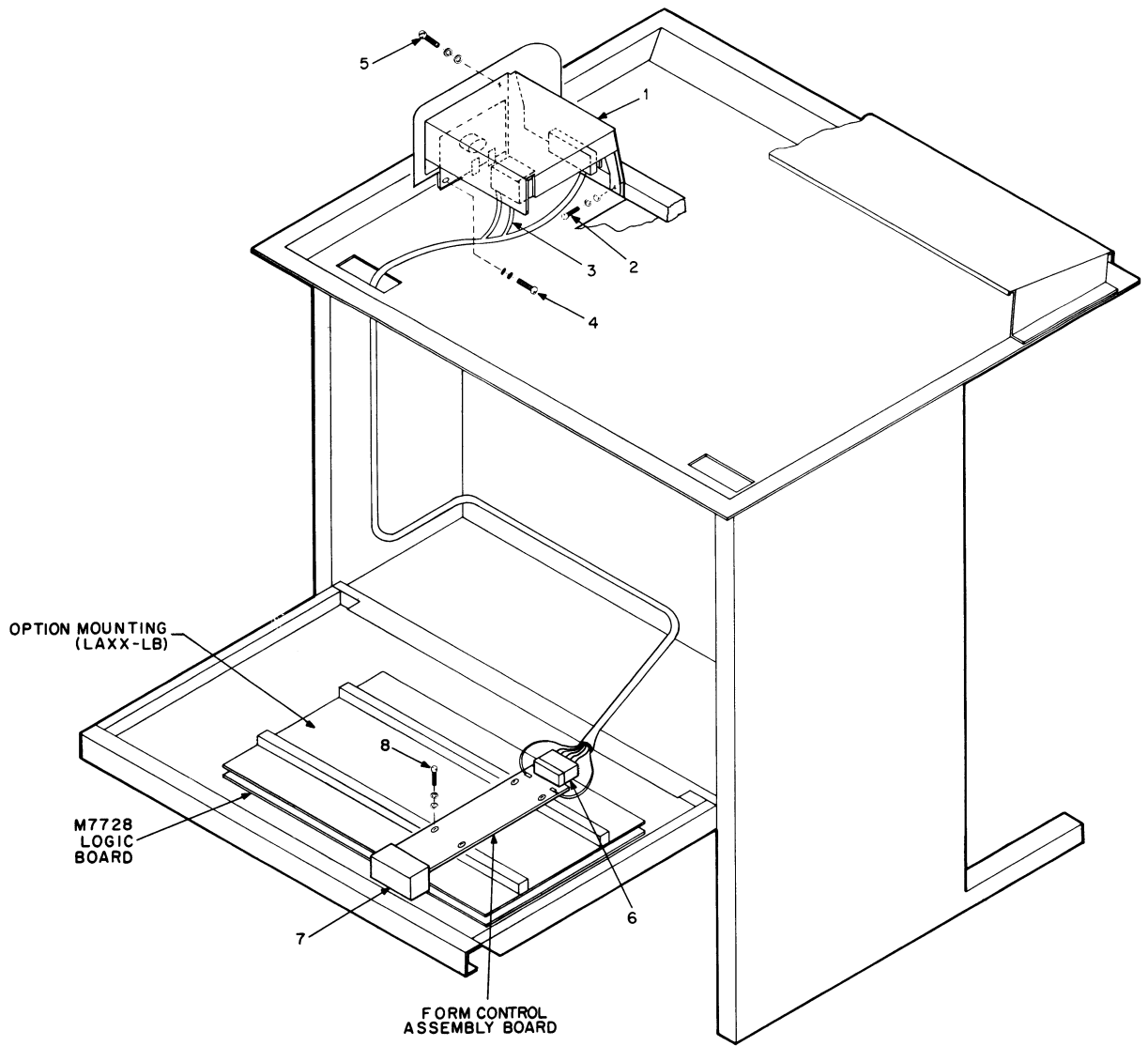

CP-2106

Figure 36 Installation of Forms Control Option Kit (LAXX-KV)

7. The top-of-form cable has two distinct ends, differing by the length of the wire leads and type of push-on connectors. The cable end with the longer leads and smaller connectors connects to the top-of-form control assembly and the other end to the top-of-form control module board. Connect the two push-on leads to the terminals on the SET TOP OF FORM switch (3) and plug in the 8-pin connector as shown.
8. Install the top-of-form control assembly using the previously removed #8-32 X 3/8-in. screw and #6 washers as shown in (5). Screw in from the outside of the bracket.
9. Feed the cable under the printer mechanism down through the access hole and, using the existing cable clamps, conform the cable as shown.
10. Position the top-of-form control module board (in location "B") on the Expander Option Mounting Kit. Secure with four #4-40 X 3/8-in. screws and #4 washers as in (8).
11. Install the H851 edge connector (7) (edge connector and board are keyed for proper fit) and the 8-pin connector (6) and two push-on connectors as shown.
12. Replace the top cover.

Test After Installation — Perform the following procedure:

1. Energize the DECwriter, load paper, and set the FORM LENGTH switch to the length of the form in inches. Press and release the SET TOP OF FORM pushbutton.
2. Issue a Form Feed Command (014g). The paper should feed and stop at a distance that is equal in inches to the switch setting. Repeat this procedure for two other switch settings, one longer, the other shorter than this setting. Press the SET TOP OF FORM pushbutton after changing the setting.
3. Set the FORM LENGTH switch to 3 and press the SET TOP OF FORM pushbutton. Issue a Line Feed command (012g) 17 times, then issue a Form Feed command (014g). The paper should increment only one line.

FORMS CONTROL, VERTICAL TABULATION, AND HORIZONTAL TABULATION OPTION KIT (LAXX-KY)

The Forms Control, Vertical Tabulation and Horizontal Tabulation Option Kit contains the Forms Control Option Kit (LAXX-KV) and the following:

Quantity	Item	Part Number
1	Top-of-Form Control Assembly	D-AD-7011503-0-0
1	HT-VT-TOF Module Board	D-CS-M7736-0-1
1	Top of Form Cable	D-IA-7011516-0-0
2	Phillips Pan Head Screws (#4-40 X 3/8 in.)	9006011-1
4	Phillips Pan Head Screws (#6-32 X 3/8 in.)	9006022-1
1	Edge Connector	B-UA-H851-0-0
2	Lock Washers (No. 4)	9006688
6	Lock Washers (No. 6)	9007801
2	Flat Washers (No. 4)	9006655
4	Flat Washers (No. 6)	9006653

A Phillips screwdriver is the only tool required for installation. Use Figure 37 and the following procedure as installation guides.

1. Unplug the ac power cord and remove the top cover.
2. If not already installed, install the Expander Option Mounting Kit (LAXX-LB).
3. Refer to Figure 33 for the correct interface cabling required to integrate the Forms Option into the existing options.
4. Unscrew the attaching hardware of the bell speaker. Save the two #6 flat washers and two #6-32 X 3/8-in. screws but discard the Kep nuts.
5. Remove and save the bracket hardware (2) (#8-32 X 3/8-in. screw, #8 lock and flat washers).
6. Attach the speaker to the inside of the top-of-form control assembly (1). Use four #6-32 X 3/8-in. screws, #6 flat and lock washers and secure from the inside as in (4).

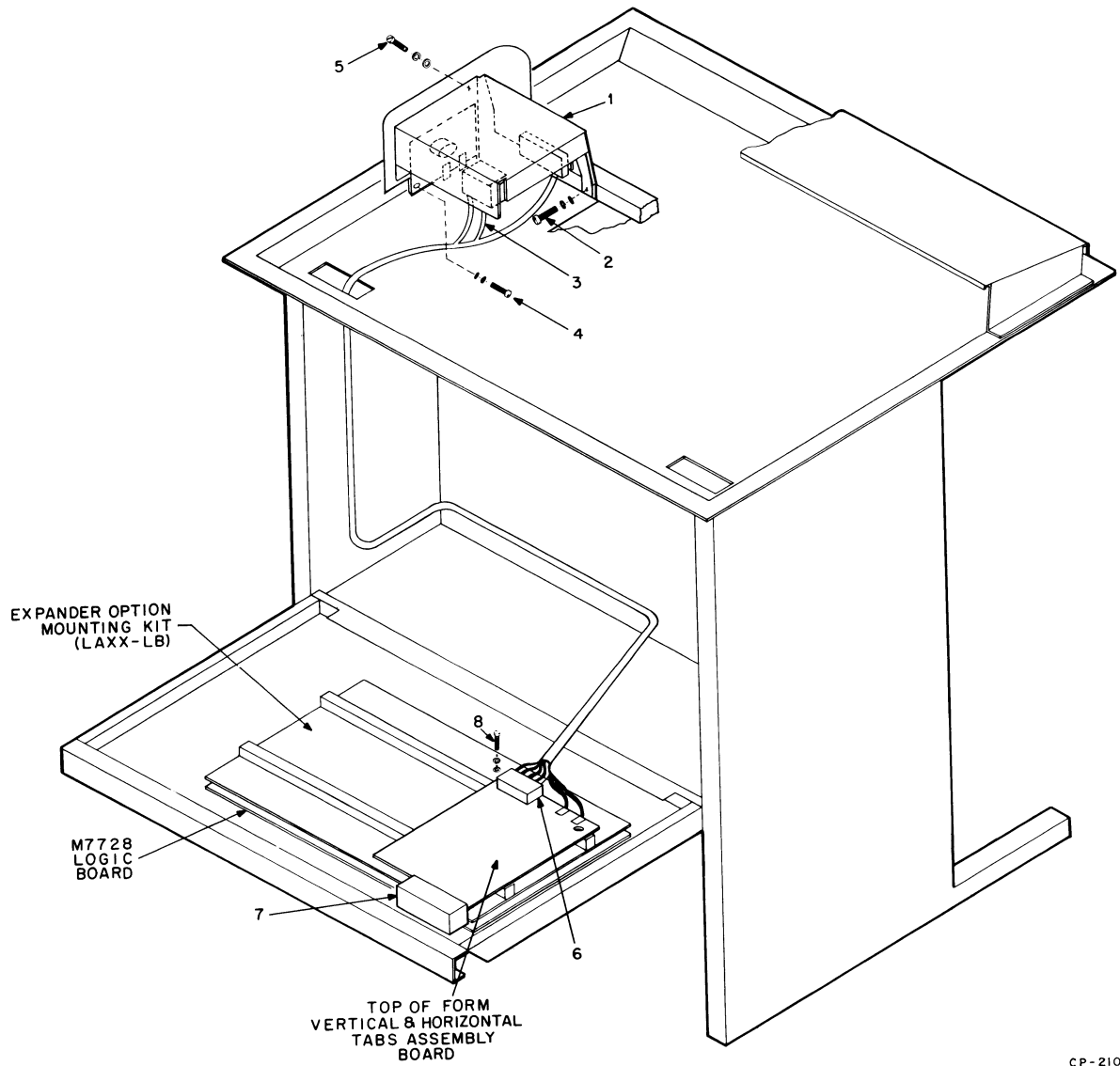

CP-2107

Figure 37 Installation of Forms Control, Vertical Tabulation, and Horizontal Tabulation Option Kit (LAXX-KY)

7. The top-of-form cable has two distinct ends, differing by the length of the wire leads and the size of the push-on connectors. The cable end with the longer leads and smaller connectors connects to the top-of-form control assembly and the other end to the HT-VT-TOF module board. Connect the two push-on leads to the terminals on the bottom of the SET TOP OF FORM switch (3) and plug in the 8-pin connector as shown.
8. Install the top-of-form control assembly using the previously removed #8-32 X 3/8-in. screw and #8 washers as shown in (2). Then secure with two #6-32 X 3/8-in. screws and #6 washers as shown in (5). Screw in from the outside of the bracket.
9. Feed the cable down through the access hole and, using the existing cable clamps, conform the cable as shown.
10. Position the HT-VT-TOF module board (in locations A and B) on the Expander Option Mounting Kit. Secure with two #4-40 X 3/8-in. screws and #4 washers as in (8).
11. Install the H851 edge connector (7) in location A (edge connector and board are keyed for proper fit) and the 8-pin connector (6) and two push-on connectors as shown.
3. Set the FORM LENGTH switch to 3 and press the SET TOP OF FORM pushbutton. Issue Line Feed (012g) 17 times, then issue a Form Feed Command (014g). The paper should increment only one line.
4. After ensuring correct operation of the Forms Control function, set the TOF for 11-in. form paper. (Set switch at 11; press pushbutton.)
5. Issue an "A" (101g).
6. Issue 013g; the DECwriter will line feed 11 in. Issue a "B" (102g).
7. Issue 012g 10 times, issue 033g and 063g then issue a "C" (103g).
8. Issue 014g. Issue a "D" (104g). Manually turn the paper back until the print head aligns at the line where "B" was printed.
9. Issue 013g, issue an "E" (105g) (will print next to previously printed "C").
10. Issue 013g, issue an "F" (106g) (will print next to previously printed "D").
11. Issue 033g and 064g, then manually turn the paper back to the line with "B" on it.

NOTE

Only one H851 edge connector is needed.

12. Replace top cover.

Test After Installation — Perform the following procedure:

1. Load paper, energize the DECwriter, and set the FORM LENGTH switch to correspond to the length of the form in inches. Press and release the SET TOP OF FORM pushbutton.
2. Issue any character, then issue a Form Feed command (014g). The paper should feed and stop at a distance that is equal in inches to the switch setting. Repeat this procedure for two other switch settings, one longer, the other shorter than this setting. Press the SET TOP OF FORM pushbutton after changing the setting.
12. Issue 013g; the print head will align on the line containing "D" and "F."
13. Issue 012g, 015g, and 011g. The print head will move to the right margin (column 132).
14. Issue 015g, then issue 040g eight times.
15. Issue 033g and 061g, then issue an "A" (101g).
16. Issue 040g eight times; issue 033g and 061g; issue a "B" (102g).
17. Issue 040g eight times; issue 033g and 061g; issue a "C" (103g).
18. Issue 031g; issue 012g.
19. Issue 011g; issue a "D" (104g).
20. Issue 011g; issue an "E" (105g).

21. Issue 011g; issue a "F" (106g).
22. Issue 011g; the head will move to column 132. The printed characters will be in two lines with the top line one character space to the right of the second line.
23. Issue 031g; issue 011g twice, then issue 020g ten times.
24. Issue 011g; issue a "G" (107g).
25. Issue 011g; issue an "H" (108g). The characters "G" and "H" will overprint on the previously printed "E" and "F."
26. Issue 033g and 062g; issue 031g; issue 011g. The print head will move to column 132. The test is completed.

AUTOMATIC LINE FEED OPTION KIT (LAXX-LA)

The Auto Line Feed Option Kit contains the following:

Quantity	Item	Part Number
1	Auto Line Feed Board	D-CS-M7738-0-1
2	Edge Connector	B-UA-H851-0-0
3	Phillips Pan Head Screws (#4-40 X 0.38 in.)	9006011-1
3	Lock Washers (#4)	9006688
3	Flat Washers (#4)	9006655

A Phillips screwdriver is the only tool required for installation. Use Figure 38 and the following procedure as installation guides.

1. Unplug the ac power cord.
2. If not already installed, install the Expander Option Mounting Kit (LAXX-LB).
3. Refer to Figure 33 for the correct interface cabling required to integrate the Auto Line Feed Option into the existing options.
4. Using the supplied hardware (1) (three #4-40 X 0.38-in. screws and #4 washers), secure the Auto Line Feed board in locations C and D on the expander board. As shown, one of the mounting holes should not be secured.

5. Install the two H851 edge connectors (2). Edge connectors and board are keyed for proper fit.

Test After Installation — Load paper and energize. With jumper W1 not cut out, a Carriage Return command (015g) will generate a line feed. With W1 cut out, a Carriage Return command will not produce a line feed.

SELECTIVE ADDRESSING OPTION KIT (LAXX-KW)

The Selective Addressing Option Kit contains the following:

Quantity	Item	Part Number
1	Selective Addressing Board	D-CS-M7737-0-1
1	Edge Connector	B-UA-H851-0-0
2	Phillips Pan Head Nylon Screws (#4-40 X 0.38 in.)	9006401-04
1	EIA Interface Cable	C-1A-7010489-0-0

A Phillips screwdriver is the only tool required for installation. Use Figure 39 and the following procedure as installation guides.

1. Unplug the ac power cord.
2. If not already installed, install the Expander Option Mounting Kit (LAXX-LB).
3. Refer to Figure 33 for the correct interface cabling required to integrate the Selective Addressing Option into the existing options.
4. Using the supplied hardware (3) (two #4-40 X 0.38-in. screws), secure the Selective Addressing board in location E on the expander board.
5. Install the H851 edge connector (2) Edge connector and board are keyed for proper fit.
6. If the Selective Addressing Option is to be used with the EIA Interface Option (LAXX-LG), the interface cable (1) should be connected as shown (lug G on the EIA board to lug GND on the Selective Addressing board).

Test After Installation — Perform the following procedure:

1. Properly interface the DECwriter with the Selective Addressing Option to a processor or another

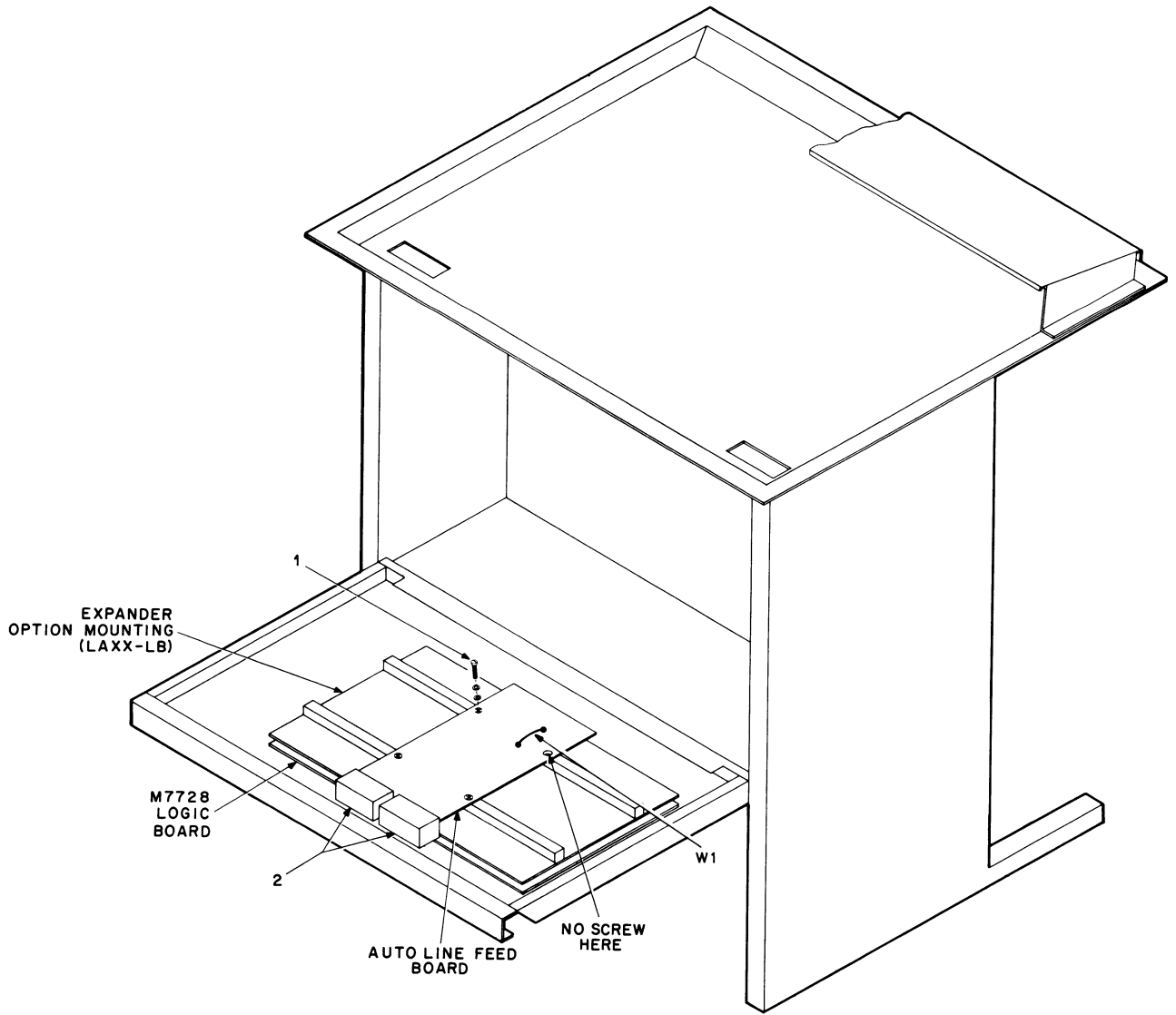

CP-2108

Figure 38 Installation of Automatic Line Feed
Option Kit (LAXX-LA)

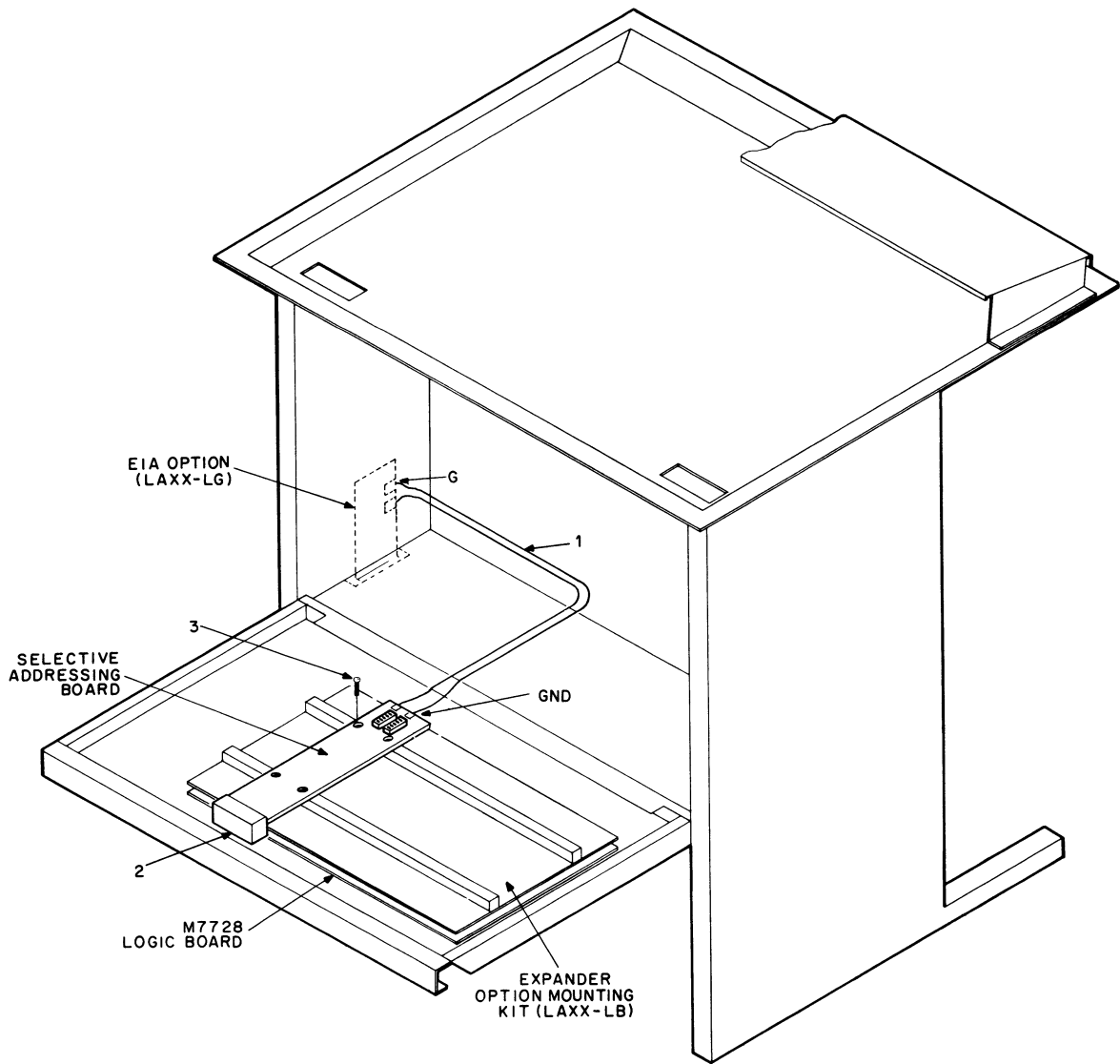

CP-2109

Figure 39 Installation of Selective Addressing Option Kit (LAXX-KW)

DECwriter without this option. (EIA interface or any other type of communications interface is acceptable.)

2. Energize both terminals; set both to line mode and to the same baud rate.

NOTE

In the following procedure, the terminal *with* the Selective Addressing Option is designated as "A" and the terminal *without* the option designated "B."

Steps 3 through 6 set up terminal A as a broadcast selected slave.

3. Transmit from terminal B; terminal A does not receive.
4. On terminal B, type CTRL G, then type CTRL B. Terminal A can receive from B.
5. On terminal B, type CTRL D.
6. Transmit from B; terminal A does not receive.

NOTE

Steps 7 through 9 set up terminal A as a group selected slave.

7. On terminal B, type the group select code that was entered into the switches on the Selective Addressing circuit board installed in terminal A.
8. On terminal B, type CTRL B. Terminal A can receive from B.
9. On terminal B, type CTRL D.

NOTE

Steps 10 and 11 set up terminal A as a uniquely selected slave.

10. On terminal B, type A's unique select code that was entered into the switches on the Selective Addressing circuit board installed in terminal A.
11. On terminal B, type CTRL B. Terminal A can receive.

NOTE

Steps 12 through 15 set up terminal A as a uniquely selected slave with add-on capability.

12. On terminal B, type CTRL B, then A's unique address code.
13. On terminal B, type any characters; A does not receive.
14. On terminal B, type CTRL C, then A's unique code again. Now type CTRL B.
15. Typing on B causes A to print.

AUTOMATIC ANSWERBACK OPTION KIT (LAXX-KX)

The Auto Answerback Option Kit contains the following:

Quantity	Item	Part Number
1	Auto Answerback Board	D-CS-M7733-0-1
2	Edge Connectors	B-UA-H851-0-0
4	Phillips Pan Head Screw (#4-40 X 0.38 in.)	9006011-1
4	Lock Washers (#4)	9006688
4	Flat Washers (#4)	9006655

A Phillips screwdriver is the only tool required for installation. Use Figure 40 and the following procedure as installation guides.

1. Unplug the ac power cord.
2. If not already installed, install the Expander Option Mounting Kit (LAXX-LB).
3. Refer to Figure 33 for the correct interface cabling required to integrate the Auto Answerback Option into the existing options.
4. Using the supplied hardware (1) (four #4-40 X 0.38-in. screws and associated washers), secure the Auto Answerback board in locations C and D on the expander board.
5. Install the two H851 edge connectors (2). Edge connectors and board are keyed for proper fit.
6. Enter the answerback message using the 7 slide switches on the 20 character switches. Use the standard ASCII code. The ON switch position is the asserted state (high) and slide switch No. 1 corresponds to b1 of the 7-bit character.

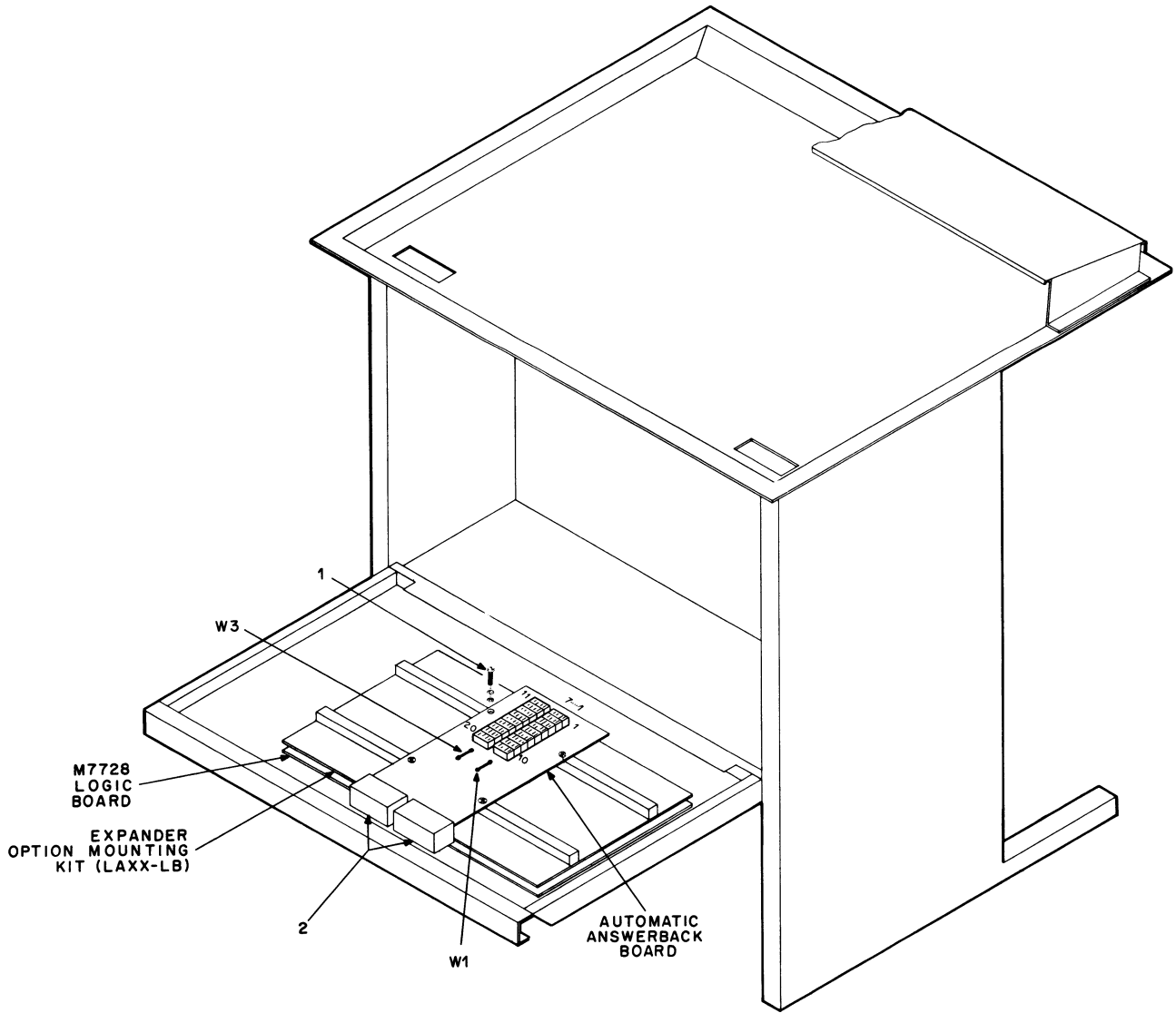

CP-2110

Figure 40 Installation of Automatic Answerback Option Kit (LAXX-Y)

Test After Installation – A received ENQ command (005_g) will generate the answerback message.

EIA INTERFACE OPTION KIT (LAXX-LG)

The EIA Interface Option Kit contains the following:

Quantity	Item	Part Number
1	EIA Interface Assembly	D-IA-7011828-0-0
2	Phillips Pan Head Screws (#8-32 X 0.38 in.)	9006037-1
2	Lock Washers (#8)	9006690-00
2	Flat Washers (#8)	9006660-00

A Phillips screwdriver is the only tool required for installation. Use Figure 41 and the following procedure as installation guides.

1. Unplug the ac power cord.
2. Disconnect the 20 mA interface input cable from J3 on the M7728 logic board.
3. Remove the two screws that hold the 20 mA interface cover plate to the floor of the cabinet and remove the complete harness assembly.
4. Insert the connector end (1) of the EIA interface cable up through the hole in the floor, then insert the EIA circuit board assembly (2).
5. Using the #8-32 X 0.38-in. screws and washers (3) supplied, secure the EIA assembly.
6. Plug the connector (1) into J4 of the M7728 logic board.
7. Connect the input end of the EIA cable assembly to the signal source.

The EIA circuit board has two wire jumpers that allow selection of the type of BREAK and DATA TERMINAL READY signals that are output by the EIA interface.

Depending on the presence of these jumpers, any of the following four terminal conditions produce the output signals.

- Paper Out
- Switch to Local Mode
- Power-up Sequence Not Completed
- Terminal Power Switched Off

The status of these jumpers produce the following outputs for any of the above conditions.

W1	W2	EIA Output Signal
Out	Out	None
Out	In	230 ms BREAK on Transmit Data Line
In	Out	DATA TERMINAL READY Disconnect

NOTE

The EIA board is shipped with both jumpers installed.

NOTE

The CARRIER DETECT signal can cause a DATA TERMINAL READY disconnect regardless of jumper presence.

Test After Installation – Send EIA data into the DEC-writer; the printout should verify a correct installation.

COMPRESSED FONT OPTION KIT (LAXX-KJ)

The Compressed Font Option Kit contains the following:

Quantity	Item	Part Number
1	30-Tooth Timing Pulley	1212446-00
1	15-Tooth Timing Pulley	D-MD-7414908-0-0
1	Pulley Clamp	C-MD-7414951-0-0
1	Timing Belt	1211583-02
1	Socket Head Cap Screw (#10-32 x 1 in.)	9006350-8
1	Hex Socket Set Screw (#1/4-20)	9007722-10
2	Kep Nuts	9006565-00
1	Right-Hand Spacer	C-MD-7415010-0-0
1	Channel Strip	9007036-00

The following tools are required for installation: socket head wrenches, Phillips screwdriver, feeler gauges, and a torque-type Phillips screwdriver. Use Figures 42 and 43 and the following procedure as installation guides.

1. Remove ac power from the DECwriter and remove the top plastic housing.
2. Remove the ribbon from the print head area.
3. Press in against the spring as in 1, Figure 42, to remove belt tension, then slide the timing belt (2) off both existing pulleys (3) and (4).
4. Using a socket head wrench, loosen the set screw in the pulley clamp (5) until the existing timing pulley (3) can be removed from the motor shaft. This pulley clamp can be discarded.
5. Loosen the set screw in the other pulley clamp (4) then remove and save this pulley.
6. Assemble the cap head screw and Kep nuts, then insert through the left side bracket as shown in (6).

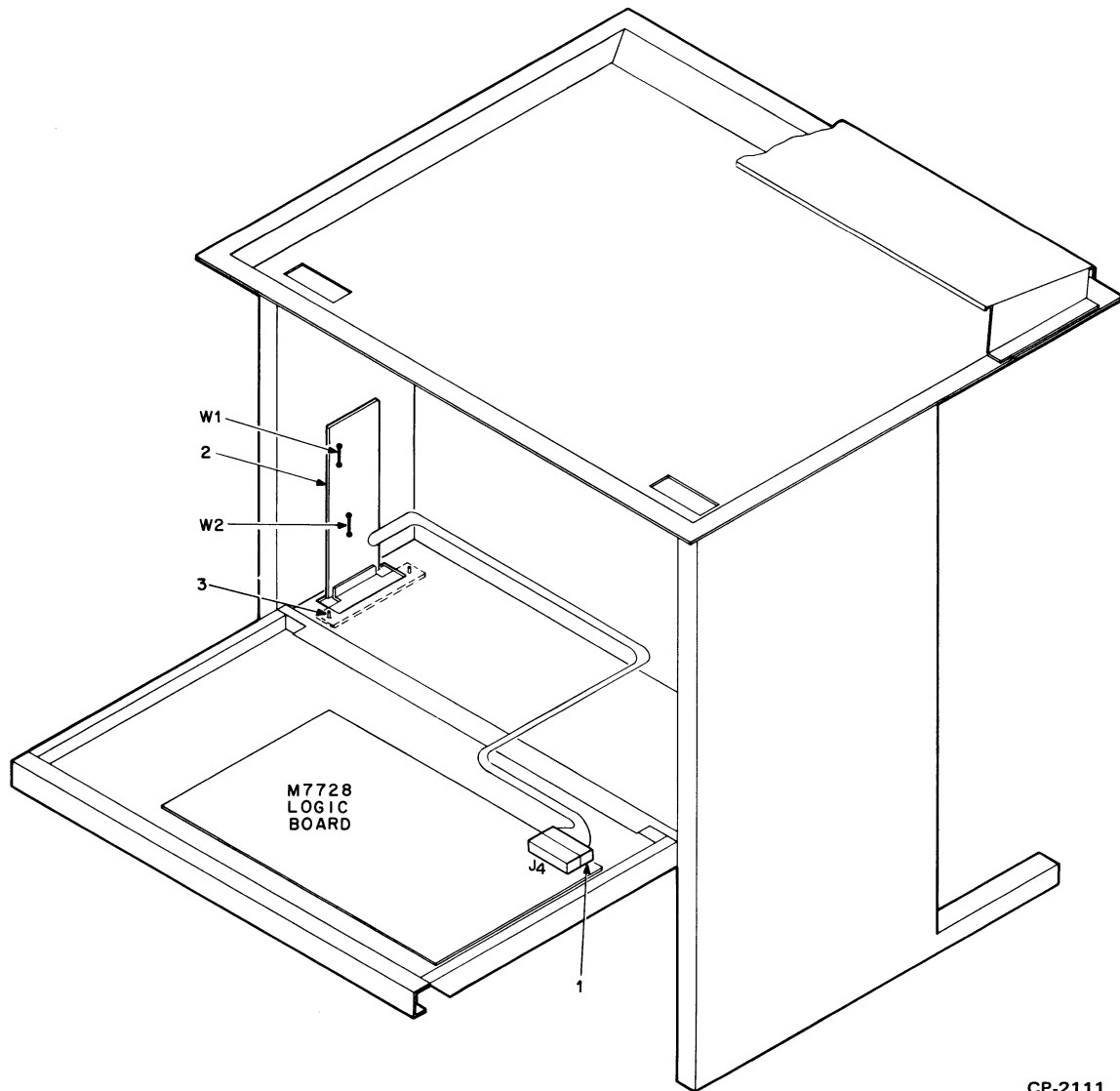

CP-2111

Figure 41 Installation of EIA Interface Option Kit (LAXX-LG)

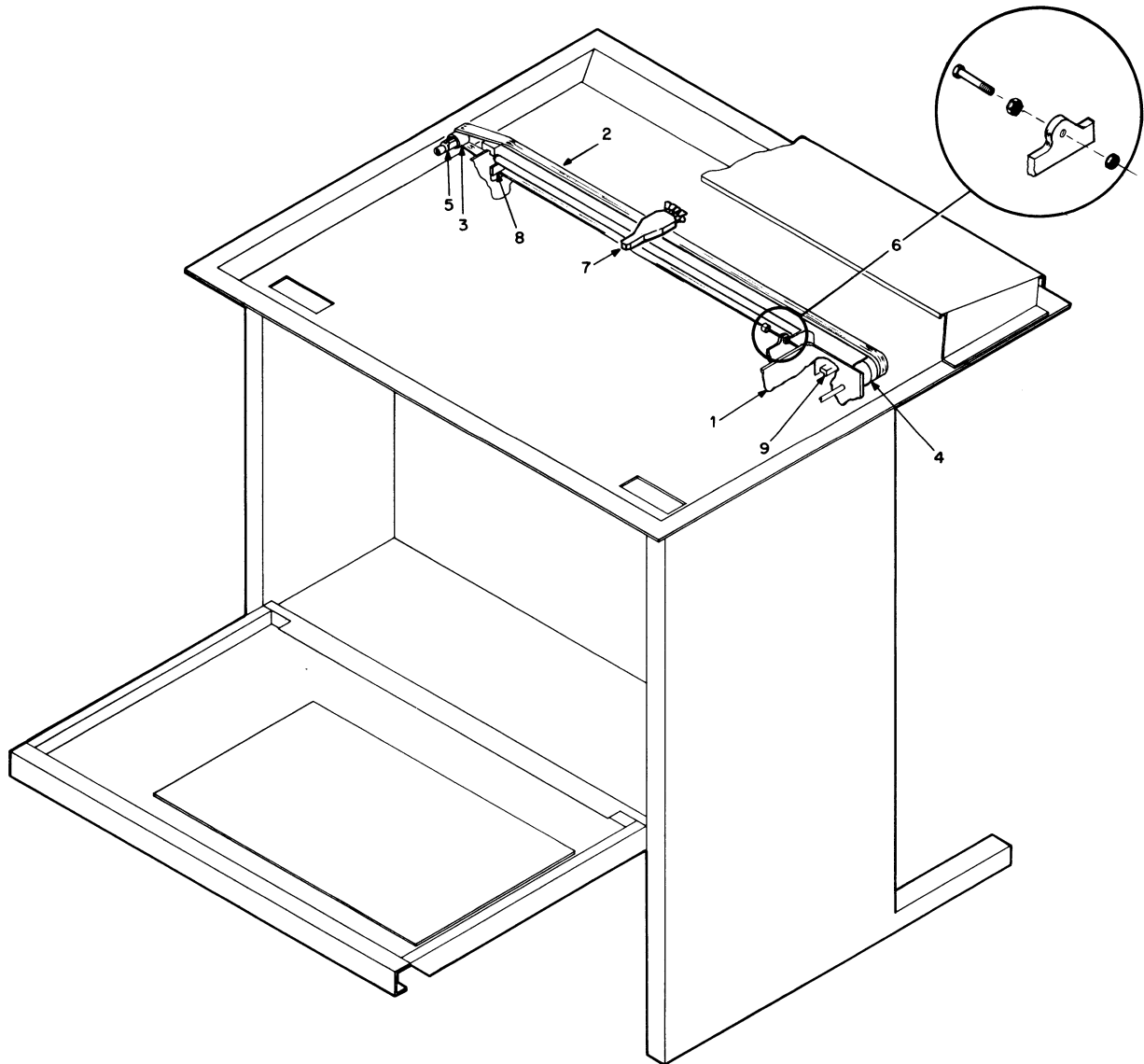

CP-2113

Figure 42 Installation of Compressed Font Option Kit
(LAXX-KJ)

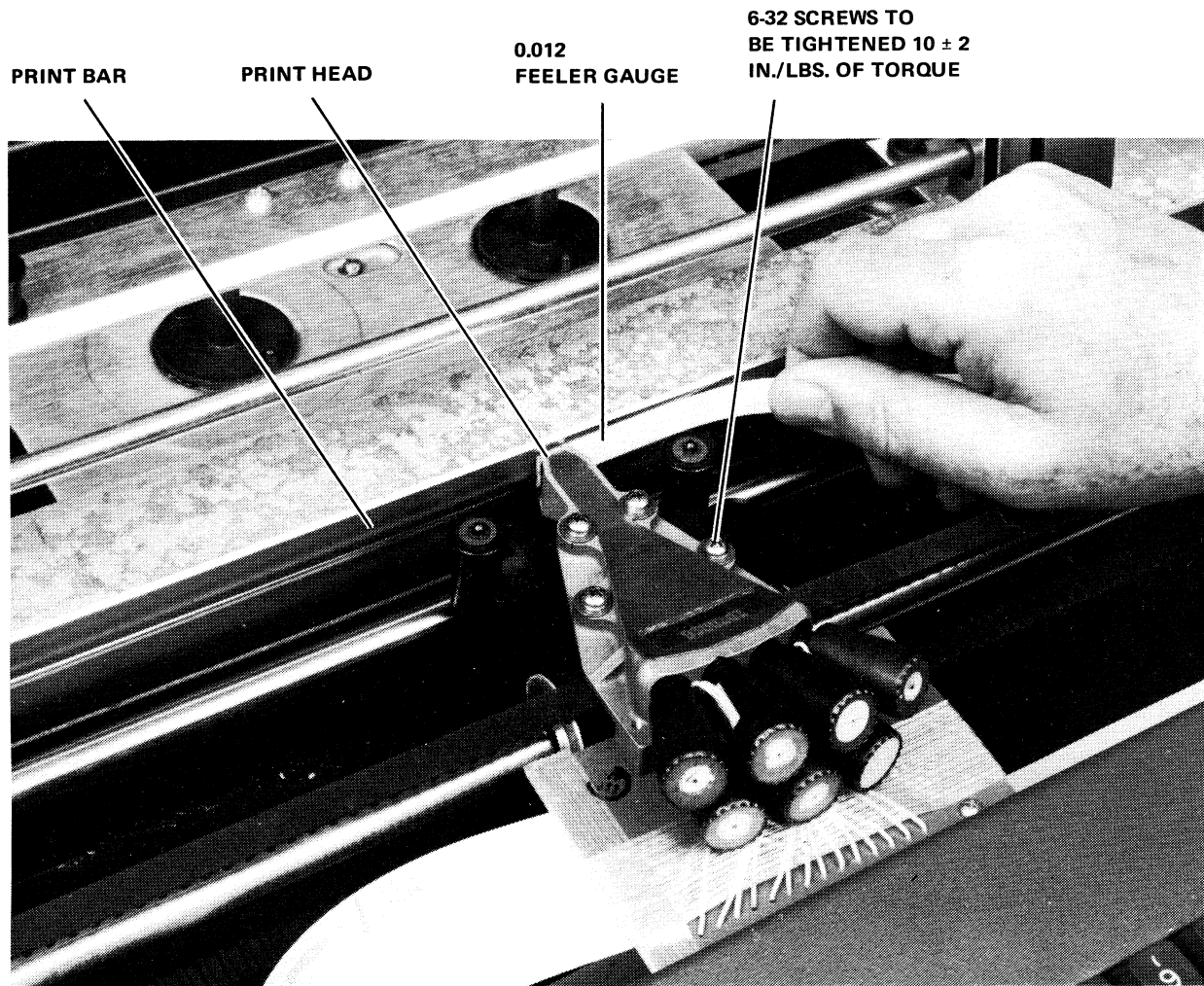

CAUTION
ENSURE THAT FEELER GAUGE IS INSERTED
BETWEEN THE PROTRUSIONS ON THE
PRINTHEAD. FAILURE TO DO SO WILL RESULT
IN IMPROPER CLEARANCE AND SHORTEN
THE LIFE OF THE PRINTHEAD.

7393-06

Figure 43 Print Head Adjustment

7. Install the new 30-tooth timing pulley on the ribbon drive shaft (4). The side of the pulley with the flange should be positioned toward the front of the machine. Position the pulley so that there is 9/32-in. clearance between the back of the pulley and the mounting hardware for the shaft bearing. Secure the new 30-tooth pulley using the previously removed pulley clamp.
8. Install the new 15-tooth pulley on the motor shaft and secure, using the new pulley clamp provided.
9. Remove the four screws (7) that secure the print head and replace the existing timing belt with the new belt supplied. Reassemble the print head but do not tighten the four mounting screws.
10. Set the Carriage Adjustment lever to the minimum gap position (detent closest to the print bar).

CAUTION
It is possible to position the Carriage Adjustment lever beyond the minimum gap position. If this is done, the correct head gap adjustment cannot be made.

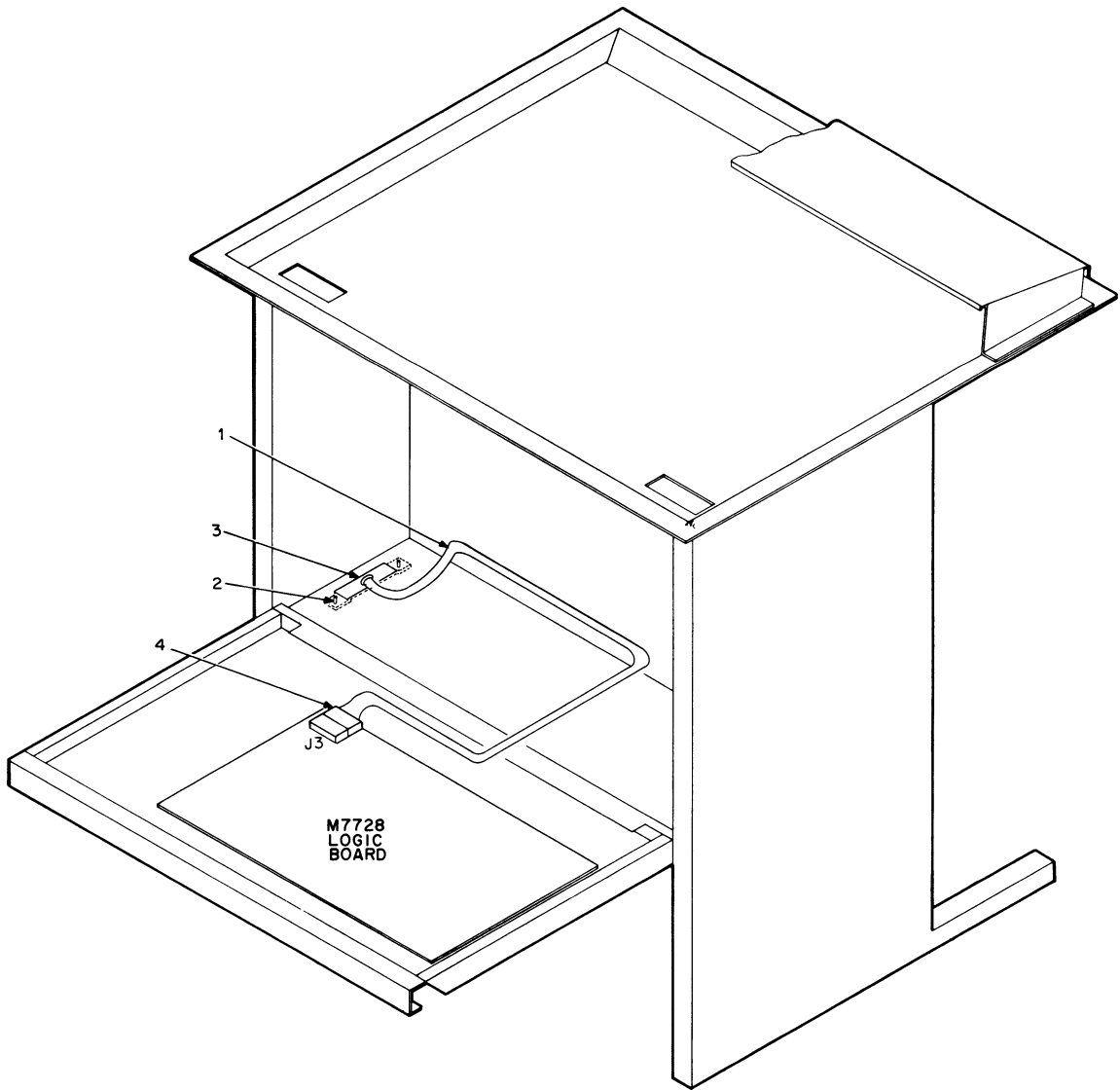

CP-2115

Figure 44 Installation of 20 mA Cable Option Kit (LAXX-LH)

11. Adjust the print head gap with the carriage in the center of travel. Place a 0.012-in. flat feeler gauge between the print head jewel and the front surface of the print bar (parallel to the print bar). Push the print head snug against the feeler (Figure 43).

Ensure that the feeler gauge rides between the protrusions on the print head. A feeler gauge with a width of 7/16 in. (or less) is needed to fit between the protrusions. Do not exert excessive force on the print head when making the adjustment; it will cause the carriage shaft to bow, resulting in more than 0.012-in. of clearance.

12. Tighten the #4 (6-32) screws to 10 ±2 in./lb of torque.

CAUTION

Do not apply more than the recommended torque when tightening the print head screws or the moulded inserts in the carriage assembly may be damaged.

13. Move the print head to the extreme right and left. Using a feeler gauge, check each position for no less than 0.010 in. of clearance between print head and print bar.
14. Recheck the gap at the center. The gap should be no greater than 0.014 in. If it is, perform steps 10 through 14 again.
15. Press against the ribbon drive assembly spring and install the new timing belt on both pulleys.
16. Adjust the cap head screw (6) so that the space between the end of the screw and the ribbon drive assembly bracket is between 0.005 and 0.010 in.
17. Rethread the ribbon, replace the plastic housing and top cover, insert paper, and apply power.

NOTE

LA35s with serial number 5568 and earlier require spacers as shown in (8) and (9). The right spacer (8) is inserted over the end of the side bracket and between the bracket and the carriage shaft. When loosening the socket head cap screw at the right end of the carriage shaft, do not allow the shaft to turn.

The channel strip spacer (9) slips over the left side bracket, as shown, to prevent the timing belt from chaffing.

Test After Installation – The DECwriter will print 132 characters in a line that is 8 in. wide. All other normal functions are unaffected.

20 mA CABLE OPTION KIT (LAXX-LH)

The 20 mA Cable Option Kit contains the following:

Quantity	Item	Part Number
1	Cable	BC05F-15
1	Cover Plate	C-MD-7413216-0-0
2	Phillips Pan Head Screw #8-32 x 0.38 in.)	9006037-1
2	Flat Washers (#8)	9006660
2	Lock Washers (#8)	9006634

A Phillips screwdriver is the only tool required for installation. Use Figure 44 and the following procedure as installation guides.

1. Disconnect and remove any previously connected data input line.
2. Insert the connector end (4) of the 20 mA cable up through the access hole in the floor and connect it to J3 on the M7728 logic board.
3. Secure the cover plate (3) using the two pan head screws and associated washers (2). Position the cable (1) as shown.
4. Connect the input end of the 20 mA cable assembly to the signal source.

Test After Installation – Send data into the DECwriter; the printout should verify a correct installation.

20 mA (DEC 10) CABLE OPTION KIT (LAXX-LK)

The 20 mA Cable Option Kit contains the following:

Quantity	Item	Part Number
1	Cable (2838 Connector to Mate-N-Lok Connector)	D-AI-7009212-1-0
1	Cover Plate	C-MD-7413216-0-0
2	Phillips Pan Head Screws (#8-32 X 0.38 in.)	9006037-1
2	Flat Washers (#8)	9006660
2	Lock Washers (#8)	9006634

A Phillips screwdriver is the only tool required for installation. Use Figure 45 and the following procedure as installation guides.

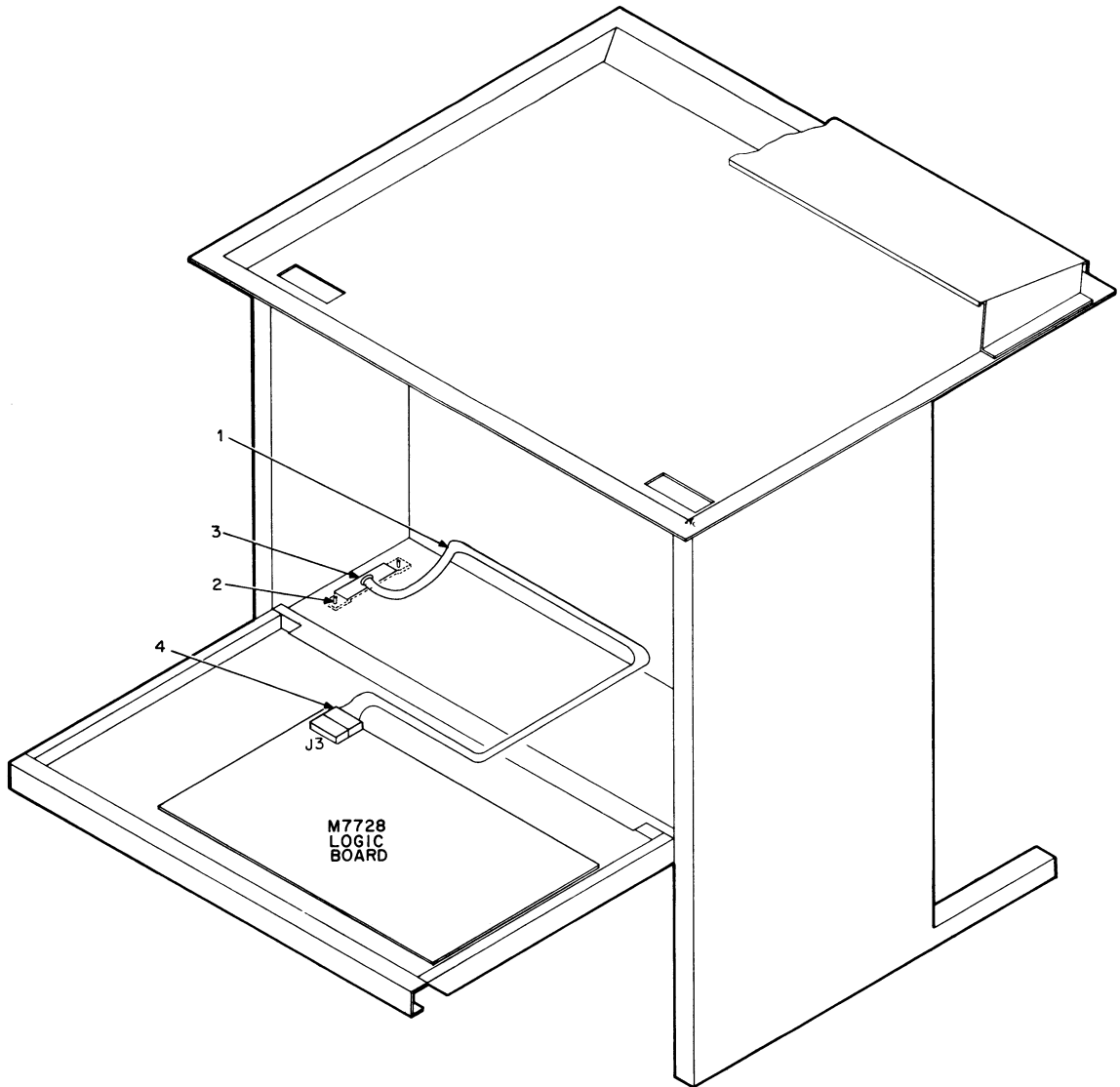

CP-2115

Figure 45 Installation of 20 mA (DEC 10) Cable Option Kit (LAXX-LK)

1. Disconnect and remove any previously connected data input line.
2. Insert the connector end (4) of the 20 mA cable up through the access hole in the floor and connect it to J3 on the M7728 logic board.
3. Secure the cover plate (3) using the two pan head screws and associated washers (2). Position the cable (1) as shown.
4. Connect the input end of the 20 mA cable assembly to the signal source.

Test After Installation – Send data into the DECwriter; the printout should verify a correct installation.

SCALE, POINTER, AND WINDOW OPTION KIT (LAXX-LN)

The Scale, Pointer, and Window Option Kit contains the following items:

Quantity	Item	Part Number
1	Column Scale	C-IA-7414986-0-0
1	Line Indicator	C-MD-7414953-0-0
1	Column Pointer	C-MD-7415409-0-0
1	Print Window	1212009-00
1	Light Shield	C-MD-7415255-0-0
1	Phillips Pan Head Screw (#4-40 X 3/8 in.)	9006011-1
1	Flat Washer (#4)	9008172
1	Lock Washer (#4)	9006632

A Phillips screwdriver is the only tool required for installation. Use Figures 2 and 46 plus the following procedure as installation guides.

1. Unplug the ac power cord, remove the paper, and remove the top cover.
2. Install the line indicator on the print head assembly using the two front Phillips screws. Remove the screws, insert the line indicator beneath the ribbon (do not interfere with the ribbon's path), then secure with the screws.

3. The column pointer (2) and its associated spacer are manufactured as a single unit. The spacer is attached to the side of the pointer by a thin web. Before installing the pointer, these two parts must be separated at this web. Fold the spacer down under the pointer to break apart.
4. Install the column pointer and spacer on the line indicator using the #4 screw, lock washer, and flat washer (3).

NOTE

If after installing the print window, the green and red positioning lines on the column pointer seem to be too high above the lip of the window, remove the spacer from beneath the column pointer.

5. The light shield (4) is a flat-black surface that minimizes glare and reflections. The shield mounts on the sloped surface of the top cover. Peel off the backing and position on the cover.
6. The column scale (5) adheres to the lip on the print window (6) as shown in Figure 46. Insert A of Figure 46 details the placement of the scale on the window lip.
7. The print window (6) snaps into place in the top cover opening.
8. Insert B of Figure 46 shows the proper alignment of the line indicator and printed characters after five Ns have been printed and a backspace occurred. The right-hand vertical ascender of the last N printed should align over the right edge of the line indicator. If necessary, loosen the two mounting screws and correct the alignment.

NOTE

After installing the column scale (5) and the column pointer (2), a horizontal adjustment may be required. The green indicator line on the column pointer should align with a corresponding line on the column scale before the last character visibility (LCV) move takes place. If alignment is performed after the last character visibility move, the red line on the column pointer is used.

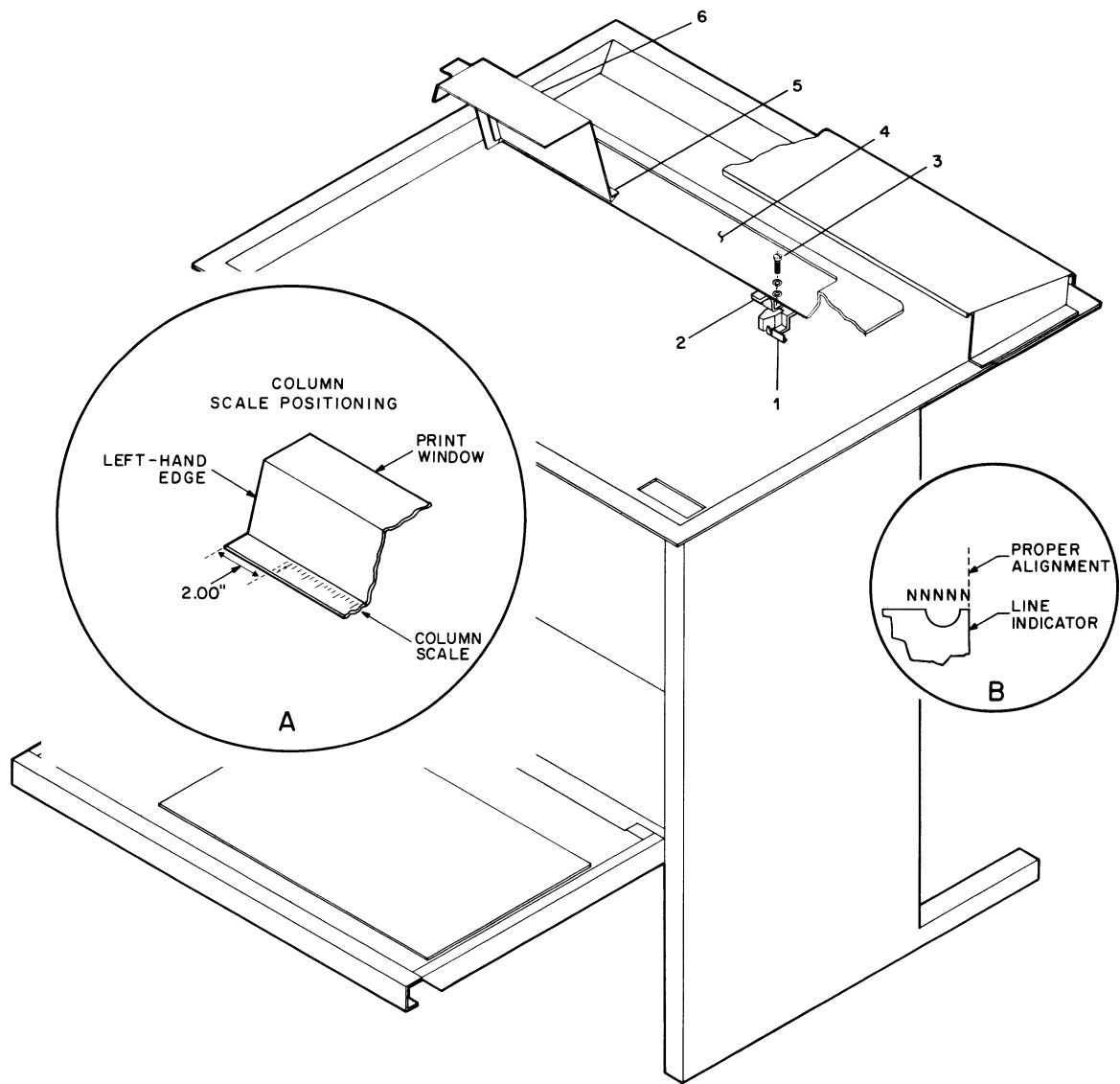

CP-2117

Figure 46 Installation of Scale, Pointer, and Window Option Kit (LAXX-LN)

DF11 ADAPTOR KIT (LAXX-KH)

The DF11 Adaptor Kit contains the following:

Quantity	Item	Part Number
1	Adaptor Bracket	C-MD-7413104-0-0
1	Wired Assembly	B-IA-7010599-0-0
1	Cable Assembly	C-IA-7010598-0-0
2	Phillips Pan Head Screws (#2-56 X 1/4 in.)	9006001-01
1	Phillips Pan Head Screw (#6-32 x 7/16 in.)	9006023-01

A Phillips screwdriver is the only tool required for installation. Use Figure 47 and the following procedure as installation guides.

1. Secure the adaptor bracket (1) to the cabinet door as shown. Use two #6-32 screws.
2. Attach the wired assembly (2) to the bracket with a #6-32 screw (3).
3. The cable assembly (4) should be soldered to the wired assembly as in Figure 47.
4. Connect the cable connector to J4 on the logic board.
5. Insert the DF11 communications option into the connector in the wired assembly (2) and secure the other end to the adaptor bracket using the two small screws supplied (#2-56). The screws insert through the hollow rivets in the DEC-CHIP handle and secure into the adaptor bracket at (5).

Test After Installation — Refer to the checkout procedures for the DF11 module installed.

ACOUSTICAL COUPLER OPTION KIT (LAXX-LM)

The Acoustical Coupler Option Kit contains a new cover (D-AD-7012144-0-0) that replaces the existing LA35 cover and a rubber "O" ring (9009793-00) that fits over the tractor drive shaft to minimize mechanical noise generation during a paper advance. A Phillips screwdriver is the only tool required for installation. Use Figures 48 and 49 plus the following procedure as installation guides.

1. Unplug the ac power cord and remove the existing top cover.
2. Remove the Paper Advance knob (2, Figure 48) by unscrewing the #6 screw (1, Figure 48) from the center of the knob.
3. After removing the Paper Advance knob from the tractor drive shaft (4, Figure 48) remove and discard the sleeve (5), then slide two "O" rings (3, Figure 48) all the way onto the shaft.

NOTE

Ensure that the "O" ring is positioned between the knob and the sleeve (5, Figure 48).

4. Replace the knob on the tractor shaft and secure with the screw and washers.
5. Insert the new cover onto the DECwriter. Press the acoustical coupler cable down through the rear access hole as shown in Figure 49.
6. Connect the cable end into the EIA connector (J4) on the logic board.

Test After Installation — Perform the following procedure:

1. Set for power on, on-line, and correct baud rate.
2. Using a telephone, call the sending system and, after hearing the carrier, place the handset into the muff assembly.

NOTE

The cord end of the handset is placed in the muff with the "dot" and/or word "CORD" next to it.

3. The carrier light illuminates within 5 seconds and then normal system operation can be performed.

NOTE

Prior to removing the telephone handset from the muff assembly, place the DECwriter in the local mode. This action prevents the disconnect noise from causing printing of random characters.

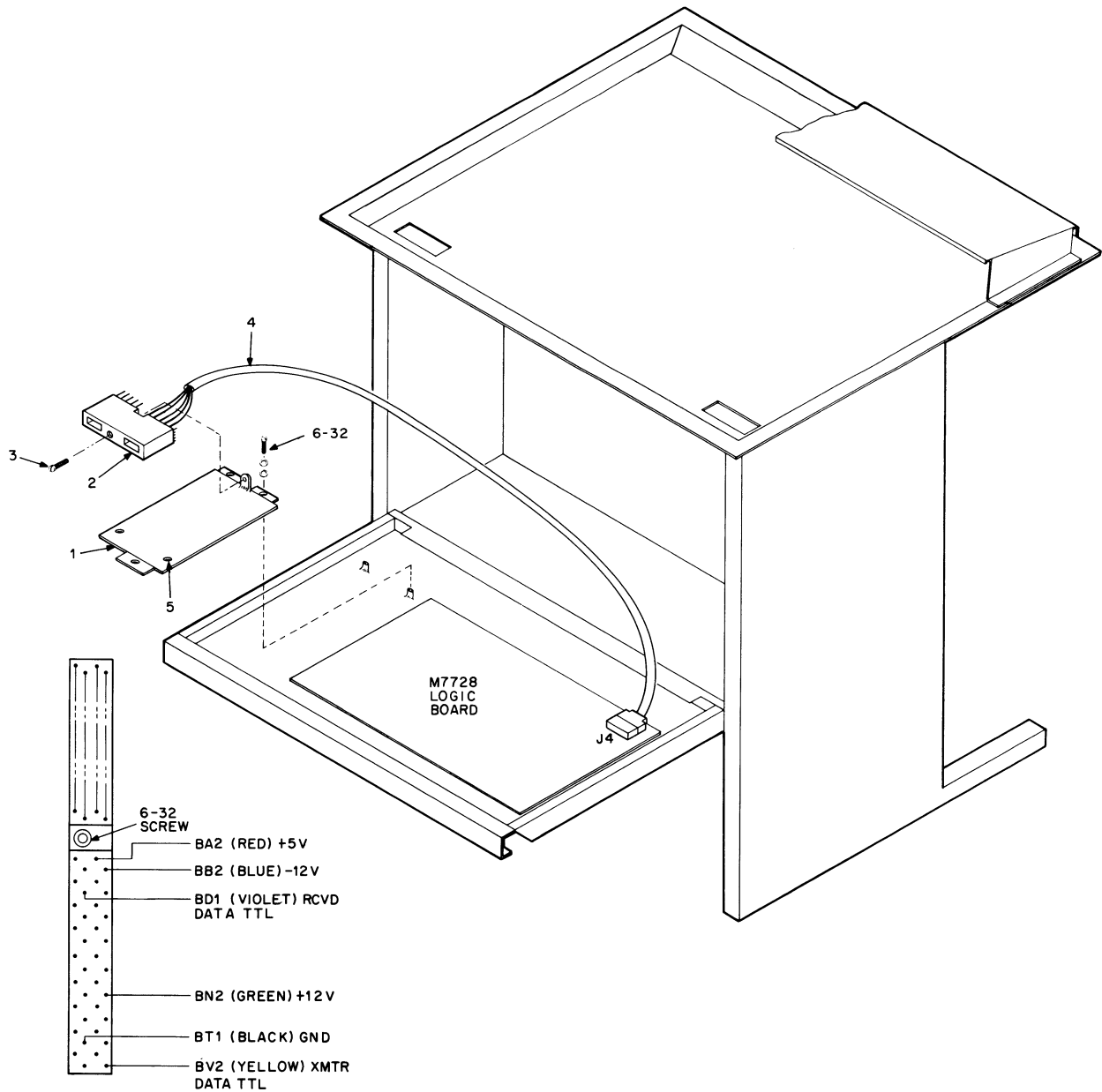

CP-2118

Figure 47 Installation of DF11 Adaptor Mounting Kit (LAXX-KH)

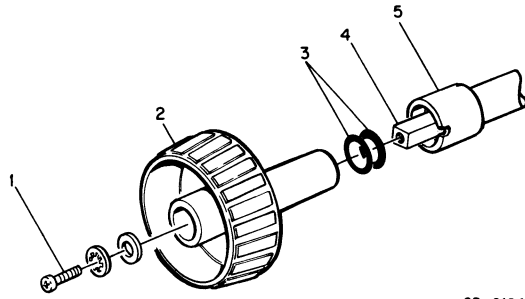

CP-2184

Figure 48 Installation of "O" Ring on Tractor Drive Shaft

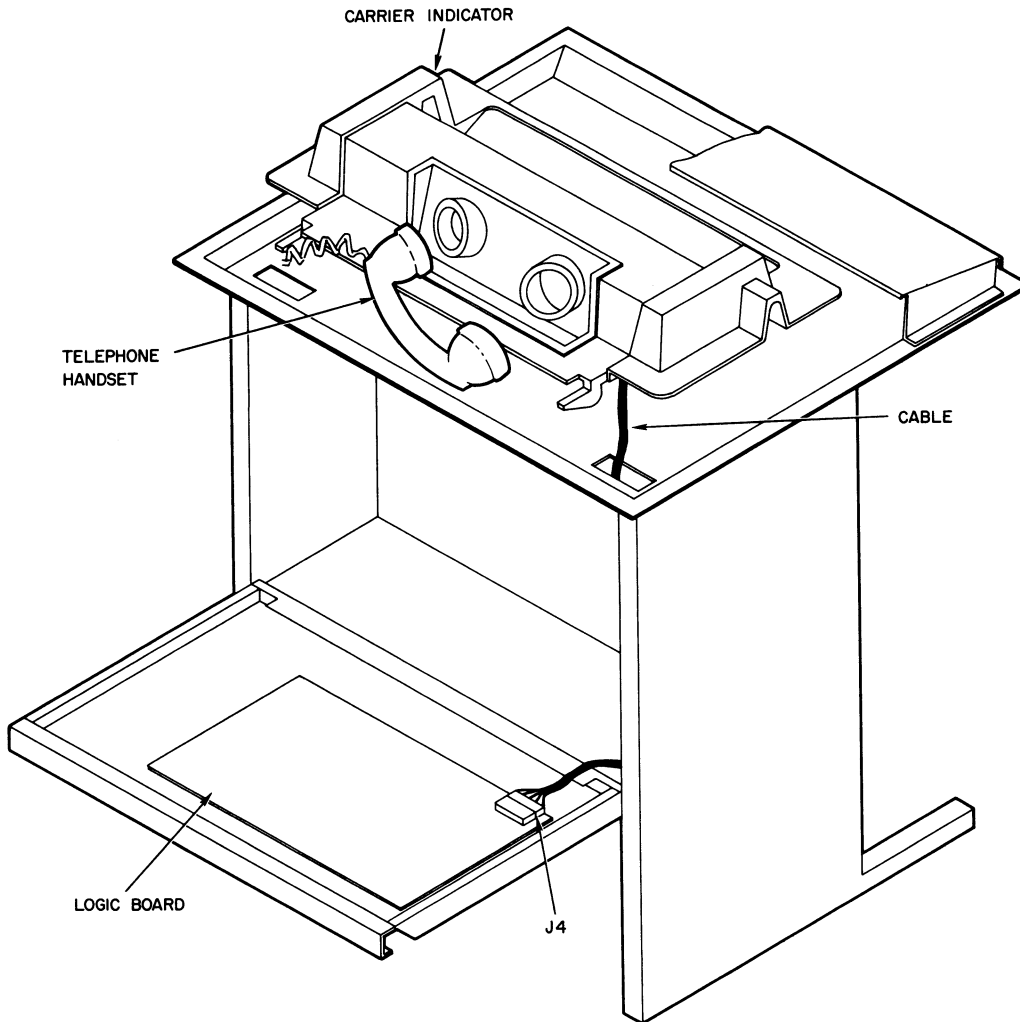

CP-2190

Figure 49 Installation of Acoustical Coupler Option Kit (LAXX-LM)

SECTION 3
COMMON INFORMATION

LOADING PAPER AND CHANGING THE RIBBON

LOADING PAPER

The LA36/LA35 can accept multipart forms, with widths from 3 to 14-7/8 in. When loading *new forms*, it is necessary to perform two adjustments:

1. Paper Positioning
2. Impression Adjustment

In addition, there is a horizontal positioning and vertical positioning adjustment. The horizontal positioning adjustment allows the paper to be slightly shifted left or right. This procedure is especially useful when typing on preprinted forms with defined horizontal zones. The vertical positioning adjustment enables the paper to be adjusted vertically. Once these adjustments have been performed, *reloading paper* becomes quick and simple, requiring a minimum of interruption.

LOADING NEW FORMS

PAPER POSITIONING PROCEDURE

1. Set the POWER switch to OFF.
2. Lift the cover.
3. Place the tractor-feed paper on the floor between the legs of the LA36/LA35. (The term tractor-feed refers to the holes on either side of the paper.)

NOTE

Ensure that the leading edge of the forms is directly below the parallel to the feed slot.

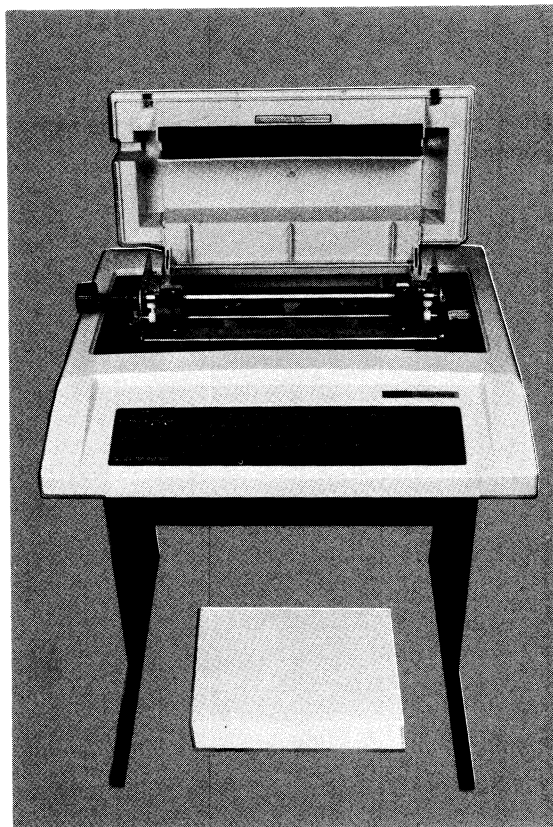

7666-14

Open the left tractor cover so that the tractor pins are exposed.

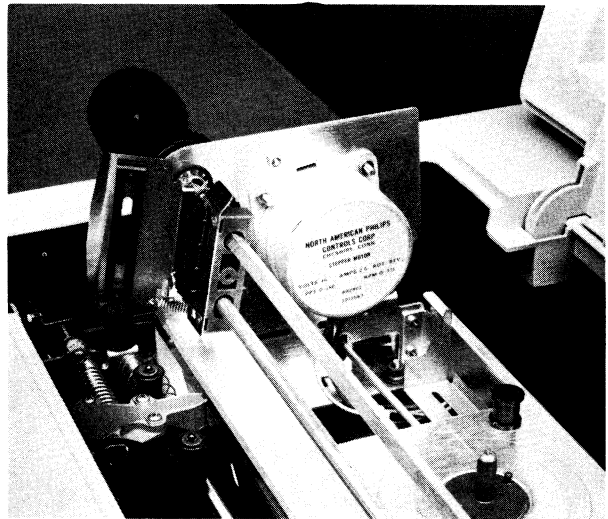

7666-32

Move the Carriage Adjustment lever to the highest number (toward operator).

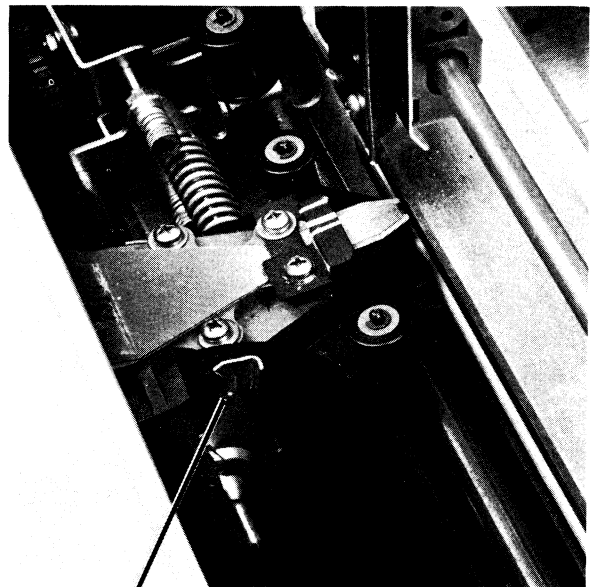

CARRIAGE
ADJUSTMENT
LEVER

7666-16

1. Feed the paper through the load channel under the terminal and align the left paper margin holes over the left tractor pins.
2. Close the left tractor cover.

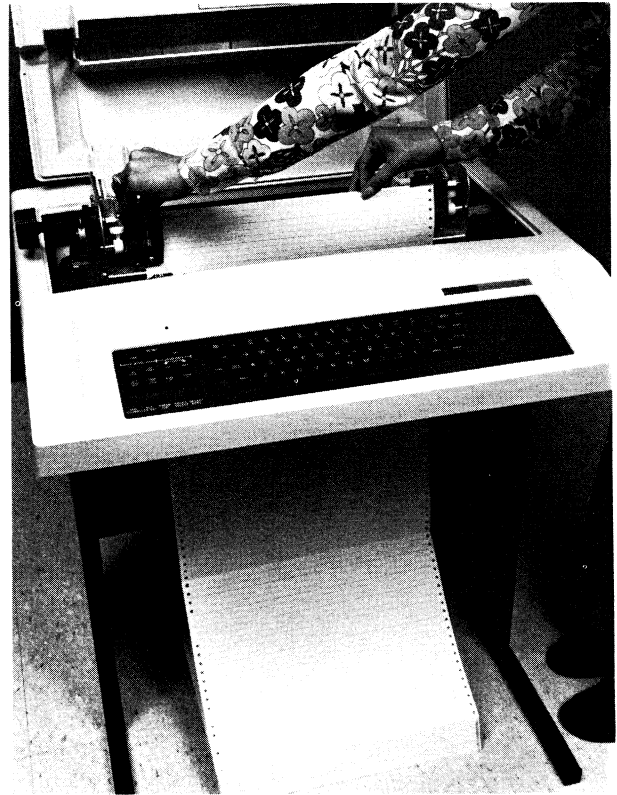

7666-33

1. Loosen the Tractor Adjustment knob on the right tractor about 1/2 turn.
2. Open the right tractor cover and slide the tractor to a position where the holes on the right paper margin align directly over the tractor pins.
3. Close the tractor cover.

NOTE

Ensure that the paper does not pull against the tractor pins or bow in the middle.

4. Tighten the tractor adjustment, and proceed to the impression adjustment.

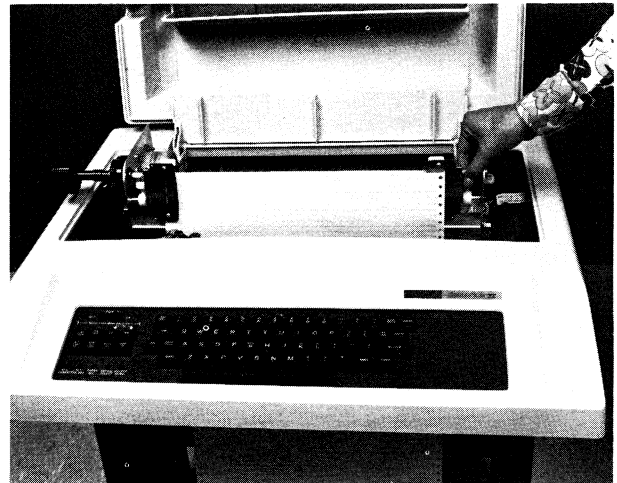

7666-35

IMPRESSION ADJUSTMENT

NOTE

The Carriage Adjustment lever is normally set forward (to notch number 1) for single thickness paper. The following procedure is applicable only to multipart forms.

1. Set the POWER switch to OFF.
2. Set the Carriage Adjustment lever to the number corresponding to the number of parts in the form.
3. Turn the Paper Advance knob counterclockwise while moving the Carriage Adjustment lever forward one notch at a time until the paper smudges; then move the lever back one notch at a time until the paper no longer smudges.
4. Set the POWER switch to ON and resume operation.

NOTE

If the impression is unsatisfactory due to a worn ribbon, perform the ribbon installation procedure. An indication of a worn ribbon is that the first copy in a multipart copy is poor but the remaining copies are good.

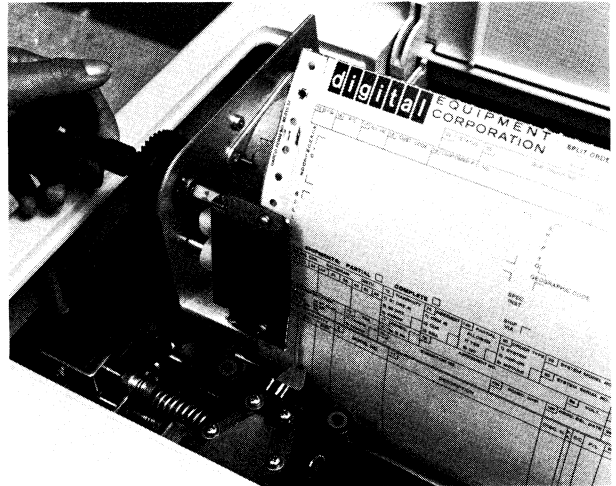

7666 3

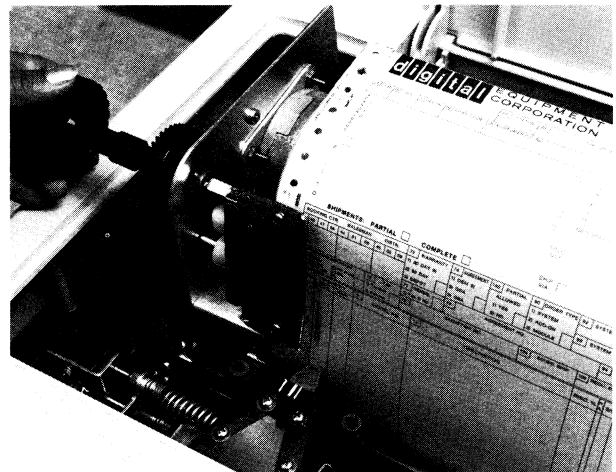

7666 6

HORIZONTAL POSITIONING ADJUSTMENT

The horizontal positioning adjustment enables the paper to be shifted left or right [1/2 in. (1.27 cm) max.]. Shifting the paper provides a simple means of aligning the type within the appropriate columns on the paper.

1. Set the POWER switch to OFF.
2. Lift the cover and loosen both Tractor Adjustment knobs about 1/2 turn.
3. Move the tractors the desired amount (1/2 in. max.) to have characters type in the appropriate columns.
4. Tighten the Tractor Adjustment knobs.

NOTE

Ensure that the paper does not pull against the tractor pins or bow in the middle.

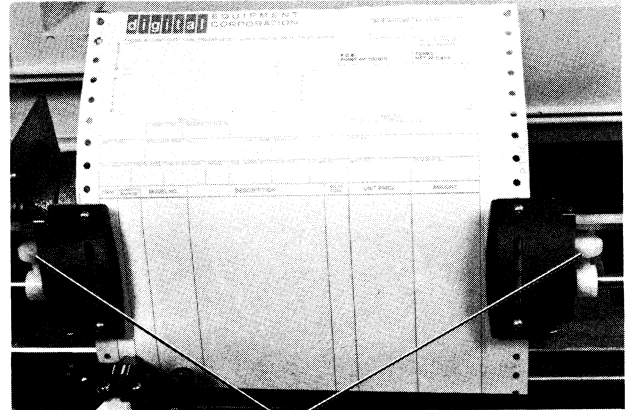

TRACTOR ADJUSTMENT KNOBS

7666 10

FINE VERTICAL POSITIONING

For fine vertical positioning, press in and turn the Paper Advance Knob.

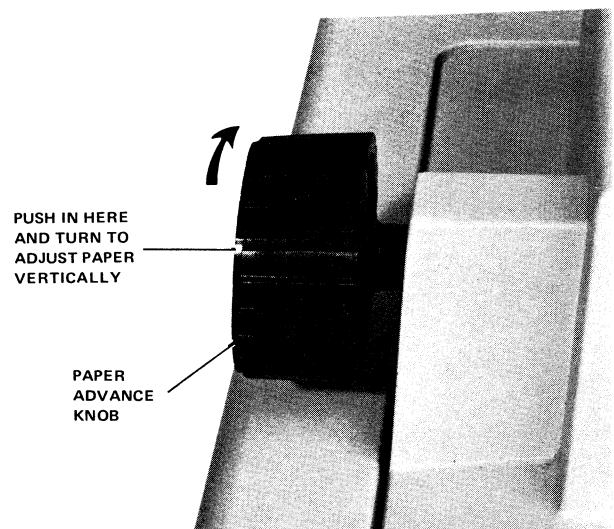

7595-4

RELOADING PAPER

1. Set the POWER switch to OFF.
2. Lift the cover.
3. Place the tractor-feed paper on the floor between the legs of the LA36/LA35.
4. Open both tractor covers so that the tractor pins are exposed.

NOTE

Ensure that the leading edge of the forms is directly below and parallel to the feed slot.

5. Feed the paper through the load channel under the terminal and align the paper holes over the tractor pins.
6. Close the tractor covers.

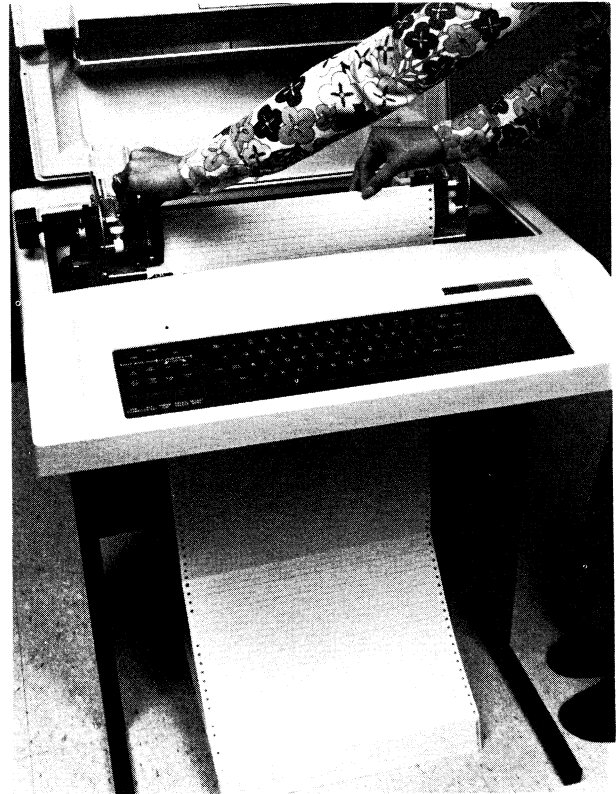

7666-33

Connect the hook on the end of the ribbon to the empty spool.

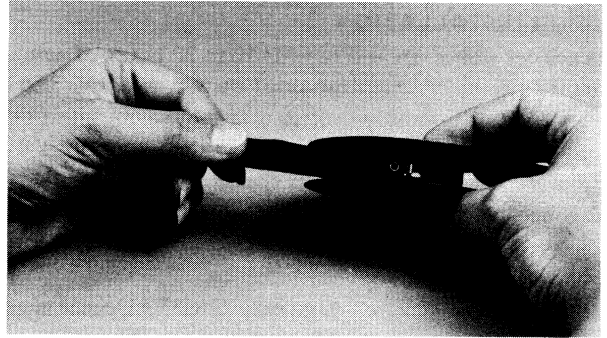

7666-17

Wind 10 turns of ribbon on the empty spool.

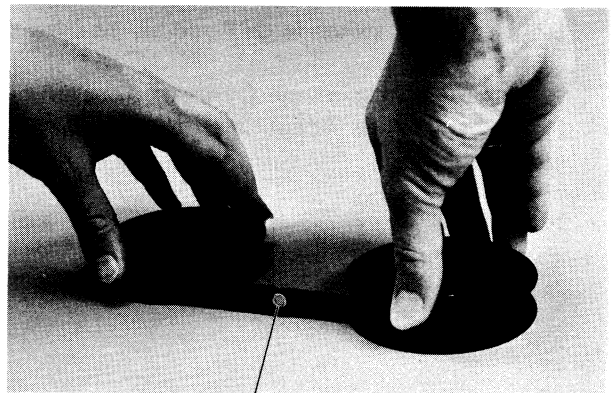

RIVET

7666-21

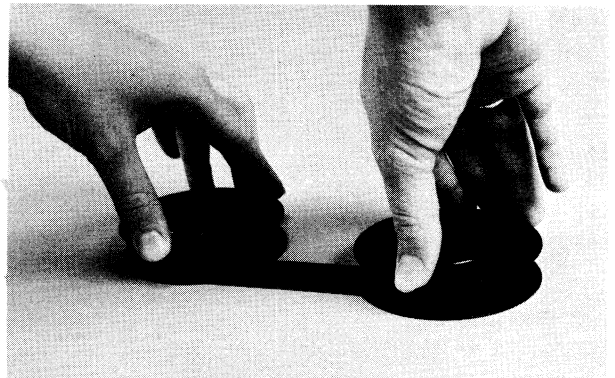

7622-22

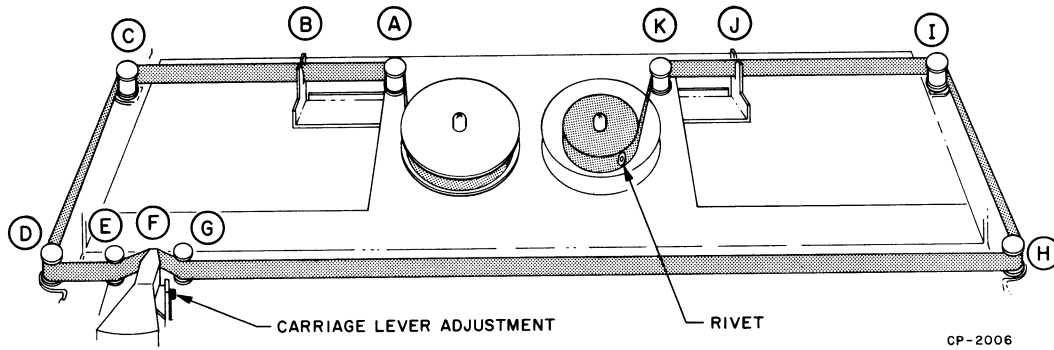

1. Place the full spool on the left spindle and turn clockwise until it drops into position.
2. Guide the ribbon around idler spool A through guide B, and around the outside of idler spools C through E.
3. Guide around the front of head F and idler spools G through I.
4. Guide the ribbon through slot J (direction changing guide) and around idler spool K.
5. Turn the spool clockwise until it drops into position.
6. Take up the slack in the ribbon by turning the free moving spool.
7. Return the Carriage Adjust lever to its original setting.

NOTE

The rivet located on the ribbon must be on the spool or between the spool and the Direction Changing guide.

Ribbon can be threaded in the opposite direction (from K to A).

DECwriter INTERFACE INFORMATION

INTERFACE DESCRIPTION

NOTE

The LA35 and LA36 have identical interfaces. However, the LA35 utilizes only the receive circuitry.

There are three interface option kits available for the DECwriters: LAXX-LH, 20 mA Cable Option Kit; LAXX-LK, 20 mA Cable Option Kit (DEC-10); LAXX-LG, EIA Interface Option Kit. Refer to Sections 1 or 2 of this manual for installation instructions for these interfaces.

INTERFACE SPECIFICATIONS

The interface specifications for the DECwriter serial 20 mA current loop are shown below:

Transmitter (LA36 only)

Passive, isolated, goes to Mark state when power is turned off.

	Min.	Max.
Open circuit voltage (of circuit being driven)	5.0 V	40 V
Voltage drop, Marking	0.5 V	2.0 V
Spacing current	0.4 mA	2.0 mA
Marking current	20 mA	80 mA

Receiver

Passive, isolated

	Min.	Max.
Voltage drop, Marking	1.2 V	2.7 V
Spacing current	0.0 mA	3.0 mA
Marking current	15 mA	80 mA

Cable

4-conductor LAXX-LH or LAXX-LK
(Cable extension up to 1500 ft is permitted)

Receiver/Transmitter (LA36 only)

Active, half-duplex

	Min.	Max.
Voltage drop, Marking	1.7 V	4.7 V
Spacing current	0.0 mA	3.0 mA
Marking current	15 mA	80 mA

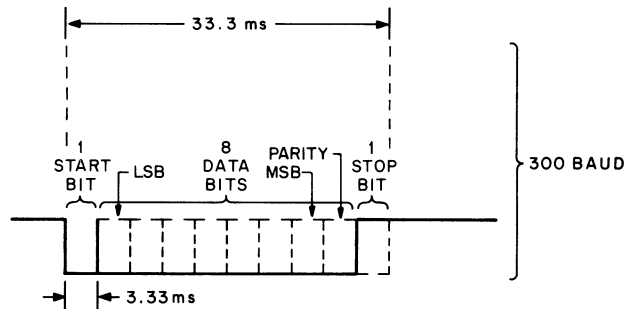
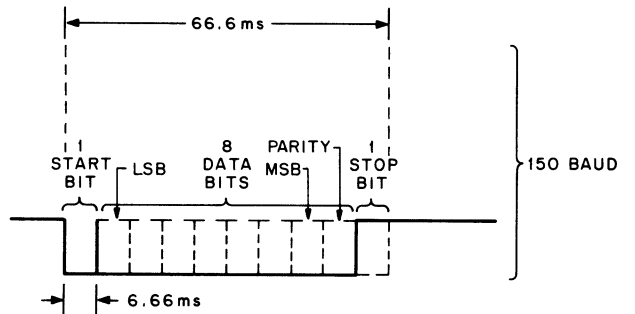
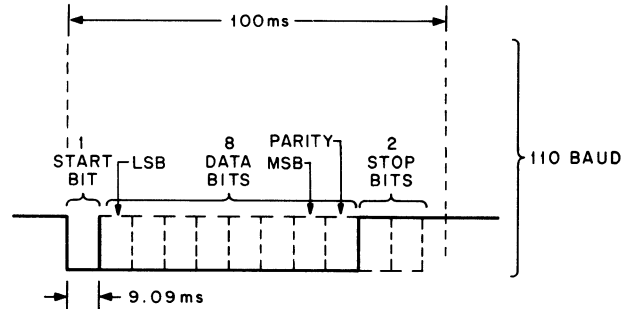

CP-1177

Serial Interface Timing Diagram

PROGRAMMER'S GUIDE

LA36 PROGRAMMER'S INFORMATION

NOTE

All information in this section is applicable to the LA35, with the exception of keyboard operations. This is due to the fact that the LA36 and LA35 receive operations and baud rates are identical.

TRANSMITTING CHARACTERS AND COMMANDS

The only way an operator can transmit data is by typing keys on the keyboard. The 7-bit ASCII equivalent of each key is transmitted the instant a key is depressed.

SPECIAL COMMAND KEYS

CTRL Key

Holding down the CTRL key changes the ASCII code transmitted when another key is typed in that it forces bits 6 and 7 to 0. For example, the ASCII code for the letter "g" is 147 (1100111)

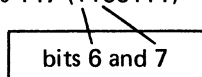

Holding down the CTRL key and typing the "G" key transmits the ASCII code 007 (0000111)

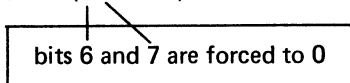

The CTRL key enables the LA36 operator to transmit all ASCII control codes (000-037).

BREAK Key

The BREAK key is commonly used to manually interrupt the flow of data coming to the LA36. The function of the BREAK key is to cause the transmitted data signal from the LA36 to go to the space condition while the BREAK key is depressed. If the LAXX-LG EIA/CCITT interface is installed, then the BREAK signal is limited to approximately 230 ms.

RECEIVING CHARACTERS AND COMMANDS

The DECwriter receives commands as well as characters to be printed in the form of 7-bit ASCII codes.

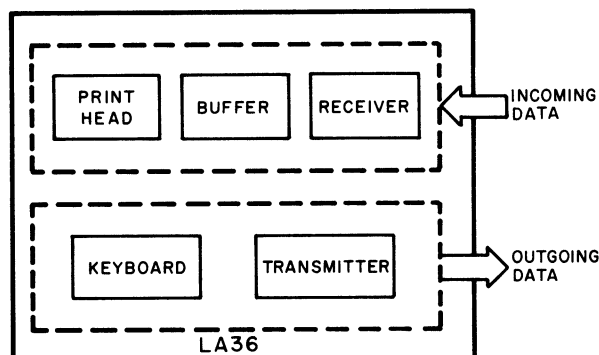

CP-1166

Normally, the DECwriter prints characters and processes commands as fast as they are received. The one exception is the RETURN operation (moving the print head back to the left margin). RETURN can take longer than the time interval between two successive data inputs. This is a normal condition for mechanical devices, which are slower than electronic signals. The normal programming practice is to compensate for this time lag by using filler characters (such as ASCII 000) to take up slack time.

In the LA35 and LA36, it is necessary that a single nonprinting, nonspacing character be sent after a carriage return or that carriage return is followed by 33.33 ms of idle (marking) line time.

The nonprinting, nonspacing character requirement is fulfilled by the line feed, (LF) code which normally will follow CR. The LF function will be executed simultaneously with CR.

Additional CR characters sent without an intervening character that causes printing or spacing will be disregarded.

The following table lists the 7-bit ASCII codes used by the DECwriter and indicates the operations performed by the printer. Note that some ASCII codes, though generated by the keyboard, are not recognized by the printer.

ASCII Code	Character	KEYBOARD OPERATIONS			RECEIVE OPERATIONS	
		To Transmit, Type Key(s)			Character Printed	Action/Description
		SHIFT*	CTRL*	CHAR		
000	NUL		✓	\	None	None
001	SOH		✓	A	↑	↑
002	STX		✓	B		
003	ETX		✓	C		
004	EOT		✓	D		
005	ENQ		✓	E		↓
006	ACK		✓	F		None
007	BEL		✓	BELL		Sound Alarm Bell
010	BS		✓	H		Backspace one position
011	HT		✓	I		None
012	LF		✓	J		Advance Paper one line
013	VT		✓	VT		None
014	FF		✓	FF		None
015	CR		✓	M		Move print head to left margin
016	SO		✓	N		None
017	SI		✓	O		↑
020	DLE		✓	P		
021	DC1		✓	Q		
022	DC2		✓	R		
023	DC3		✓	S		
024	DC4		✓	T		
025	NAK		✓	U		
026	SYN		✓	V		
027	ETB		✓	W		
030	CAN		✓	X		
031	EM		✓	Y		
032	SUB		✓	Z		
033	ESC		✓	[
034	FS		✓	\		
035	GS		✓	=		
036	RS	✓	✓	~	↓	↓
037	US	✓	✓	-	None	None
040	SP			space bar	Blank Space	Print character, move print head one position to the right.

*A check in this column indicates the key (SHIFT or CTRL) that must be held down while the character key is typed. If both keys are checked, then both keys must be held down.

		KEYBOARD OPERATIONS			RECEIVE OPERATIONS	
ASCII Code	Character	To Transmit, Type Key(s)			Character Printed	Action/Description
		SHIFT*	CTRL*	CHAR		
041	!	✓		!	!	Print character, move print head one position to the right.
042	"	✓		"	"	
043	#	✓		#	#	↑
044	\$	✓		\$	\$	
045	%	✓		%	%	
046	&	✓		&	&	
047	'			'	'	
050	(✓		((
051)	✓))	
052	*	✓		*	*	
053	+	✓		+	+	
054	,			,	,	
055	-	✓		-	-	
056	.			.	.	
057	/			/	/	
060	0			0	0	
061	1			1	1	
062	2			2	2	
063	3			3	3	
064	4			4	4	
065	5			5	5	
066	6			6	6	
067	7			7	7	
070	8			8	8	
071	9			9	9	
072	:	✓		:	:	
073	;			;	;	
074	<	✓		<	<	
075	=			=	=	
076	>	✓		>	>	
077	?	✓		?	?	
100	@	✓		@	@	
101	A	✓		A	A	
102	B	✓		B	B	
103	C	✓		C	C	↓
104	D	✓		D	D	

*A check in this column indicates the key (SHIFT or CTRL) that must be held down while the character key is typed.
If both keys are checked, then both keys must be held down.

		KEYBOARD OPERATIONS			RECEIVE OPERATIONS	
ASCII Code	Character	To Transmit, Type Key(s)			Character Printed	Action/Description
		SHIFT*	CTRL*	CHAR		
105	E	✓		E	E	Print character, move print head one position to the right.
106	F	✓		F	F	
107	G	✓		G	G	↑
110	H	✓		H	H	
111	I	✓		I	I	
112	J	✓		J	J	
113	K	✓		K	K	
114	L	✓		L	L	
115	M	✓		M	M	
116	N	✓		N	N	
117	O	✓		O	O	
120	P	✓		P	P	
121	Q	✓		Q	Q	
122	R	✓		R	R	
123	S	✓		S	S	
124	T	✓		T	T	
125	U	✓		U	U	
126	V	✓		V	V	
127	W	✓		W	W	
130	X	✓		X	X	
131	Y	✓		Y	Y	
132	Z	✓		Z	Z	
133	[[[
134	\			\	\	
135]	✓]]	
136	^	✓		^	^	
137	-			-	-	
140	`			`	`	
141	a			A	a	
142	b			B	b	
143	c			C	c	
144	d			D	d	
145	e			E	e	
146	f			F	f	
147	g			G	g	
150	h			H	h	↓ Print character, move print head one position to the right.

*A check in this column indicates the key (SHIFT or CTRL) that must be held down while the character key is typed.
If both keys are checked, then both keys must be held down.

		KEYBOARD OPERATIONS			RECEIVE OPERATIONS		
ASCII Code	Character	To Transmit, Type Key(s)			Character Printed	Action/Description	
		SHIFT*	CTRL*	CHAR			
151	i			I	i	Print character, move print head one position to the right.	
152	j			J	j		
153	k			K	k		
154	l			L	l		
155	m			M	m		
156	n			N	n		
157	o			O	o		
160	p			P	p		
161	q			Q	q		
162	r			R	r		
163	s			S	s		
164	t			T	t		
165	u			U	u		
166	v			V	v		
167	w			W	w		
170	x			X	x		
171	y			Y	y		
172	z			Z	z		
173	{			{	{		
174		✓					
175	}	✓		}	}		
176	~	✓		~	~		Print character, move print head one position to the right.
177	DEL			DELETE	None		None

*A check in this column indicates the key (SHIFT or CTRL) that must be held down while the character key is typed.
If both keys are checked, then both keys must be held down.

OPERATOR CARE, PACKING, AND REPACKING

OPERATOR CARE

1. Do not oil the DECwriter. Moving parts are prelubricated and sealed by DIGITAL.
2. Keep the cover closed whenever power is applied.
3. Use only a lint-free cloth when cleaning the cover and the keyboard. Do not use solvents or harsh cleaning agents to clean the DECwriter. If excessively dirty, a mild detergent solution or desktop cleaner may be used sparingly.
4. Do not use any DECwriter surface area to hold pencils, paper clips, staples, etc. If an object accidentally falls into the machine, turn the POWER switch to OFF, unplug the power cord from the wall outlet, and carefully remove the object.
5. Tear paper only along perforations. Support paper on the DECwriter cover when tearing to avoid distorting the tractor-feed holes in the paper still in the machine.
6. If unexpected trouble arises, refer to the Troubleshooting Guide in this section.

UNPACKING AND INSPECTION

The following procedure outlines the steps required for unpacking and inspecting the DECwriter.

1. Cut the nylon retaining straps from around the shipping carton and discard them.
2. Remove the full telescope cap and then remove the stitched tube.
3. Remove all shock-absorbing material and packing from around the DECwriter (Figure 50).
4. Remove the poly bag from the printer.
5. Remove the foam key protector pad from the keyboard.
6. Loosen and remove the hex head bolt securing the wooden leg brace to the skid assembly. Remove microfoam from around each leg of the DECwriter.

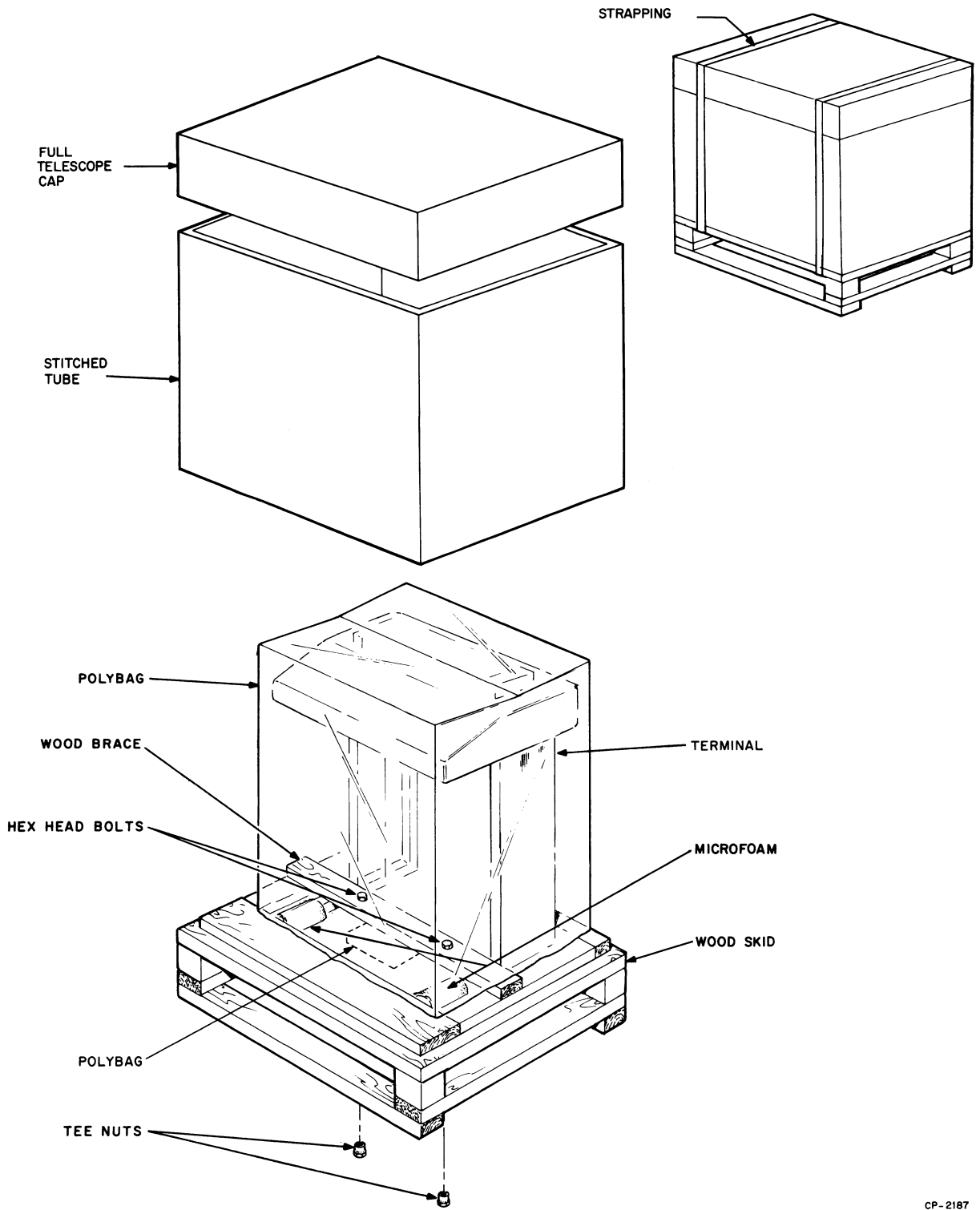
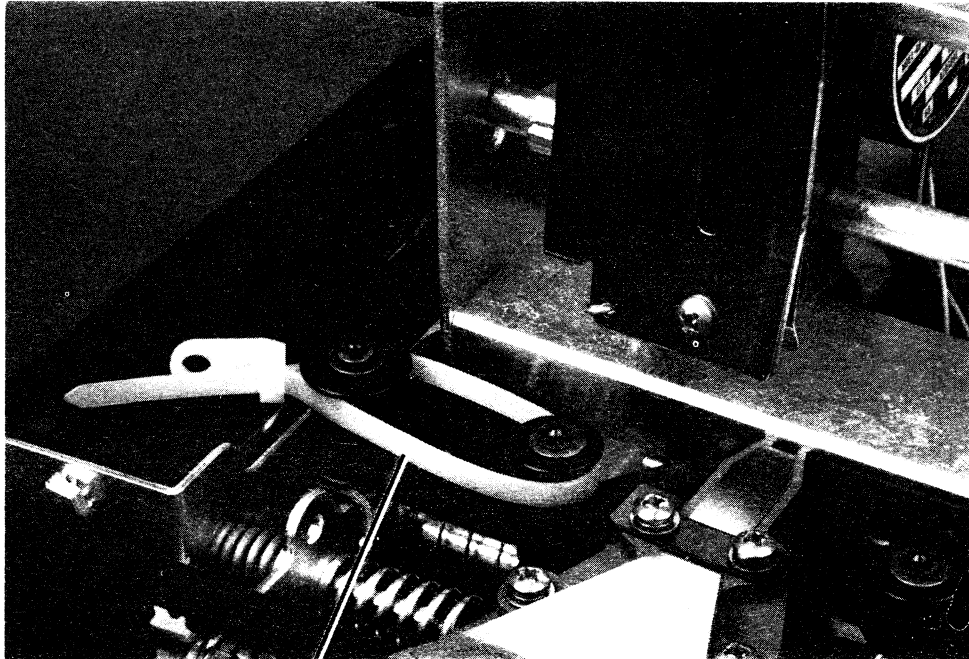

Figure 50 DECwriter Packaging

CP-2187



CABLE
TIE

7555-10

Figure 51 Cable Tie Location

7. Carefully inspect the DECwriter cabinet, keyboard, and carriage assembly for possible shipping damage. Inspect and check the enclosed packing list for lost or missing items. Report any damage or missing items to the local DIGITAL Field Service or Sales Office and to the local carrier.
8. Remove the printer from the wooden shipping skid and place it in the desired location.
9. Lift the DECwriter top cover assembly; clip and remove the nylon cable tie securing the print head assembly (Figure 51). Remove the caution tag.
10. Install and adjust the leveling feet on the DECwriter legs.
11. If necessary, wipe all outer surfaces with a clean, soft, lint-free cloth.
12. Connect the interface cable to the user's equipment. (See the DECwriter Interface Information.)

NOTE

Site plans are not supplied by Digital Equipment Corporation. Interface logic connections must be specified and provided by the system supplier, or the customer, because each installation may be different.

PACKING PROCEDURE

If it becomes necessary to ship your DECwriter to another location, repack it per the following procedure.

1. Remove the ribbon and paper.
2. Using a nylon cable tie, secure the print head assembly to prevent movement while in transit.
3. Pack the DECwriter as shown in Figure 50.

TROUBLESHOOTING GUIDE

Symptom	Possible Cause and Corrective Action
DECwriter does not turn on when POWER switch is set to ON.	<ul style="list-style-type: none"> ● AC power cord is not plugged into wall outlet – plug it in. ● Current is not coming from wall outlet – check outlet with a known working electrical device (such as a lamp). ● Check AC Line fuse (Figure 52). ● If none of the above, contact your local Field Service Office.
Print head does not print characters.	<ul style="list-style-type: none"> ● Check servo fuse – might be blown (Figure 52). ● Print head may be set too far from paper – adjust the carriage adjustment lever. ● Check option interconnect cabling (Figure 8).
Light print	<ul style="list-style-type: none"> ● Print head may be set too far from paper – adjust the carriage adjustment lever per impression adjustment procedure. ● Ribbon ink has run out – replace ribbon. ● Reverse ribbon after 8–12 hours of continuous printing. Ribbon should be reversed only once, then changed.
Paper does not advance	<ul style="list-style-type: none"> ● Improper loading of paper – check tractor covers to ensure that they are closed. ● Holes in paper are torn – turn DECwriter OFF and reload paper properly. ● Paper snagged or caught by box.
Paper tearing on multipart forms	<ul style="list-style-type: none"> ● Print head is exerting pressure on paper so that paper tears when it advances – check print head position control. (Adjust Carriage Adjustment lever.) ● Tension exerted on the paper by the tractors is incorrect.
Line bunching	<ul style="list-style-type: none"> ● Tension exerted on the paper by the tractors is excessive.

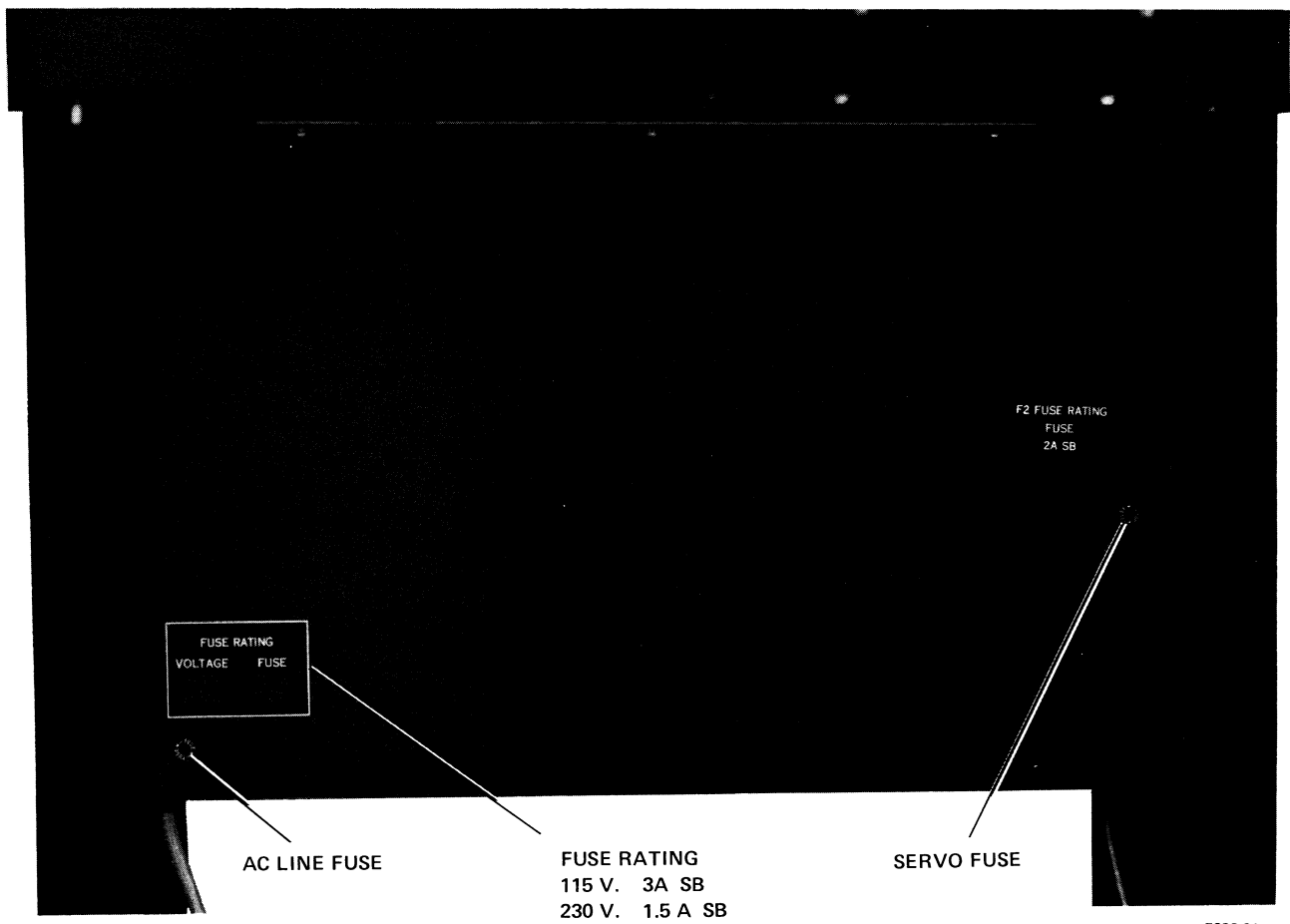

Figure 52 Fuse Locations

Reader's Comments

LA36/LA35 USER'S GUIDE
EK-LA3635-OP-002

Your comments and suggestions will help us in our continuous effort to improve the quality and usefulness of our publications.

What is your general reaction to this manual? In your judgment is it complete, accurate, well organized, well written, etc.? Is it easy to use? _____

What features are most useful? _____

What faults do you find with the manual? _____

Does this manual satisfy the need you think it was intended to satisfy? _____

Does it satisfy *your* needs? _____ Why? _____

Would you please indicate any factual errors you have found. _____

Please describe your position. _____

Name _____ Organization _____

Street _____ Department _____

City _____ State _____ Zip or Country _____

CUT OUT ON DOTTED LINE

Fold Here -----

Do Not Tear - Fold Here and Staple -----

**FIRST CLASS
PERMIT NO. 33
MAYNARD, MASS.**

**BUSINESS REPLY MAIL
NO POSTAGE STAMP NECESSARY IF MAILED IN THE UNITED STATES**

Postage will be paid by:

**Digital Equipment Corporation
Technical Documentation Department
146 Main Street
Maynard, Massachusetts 01754**

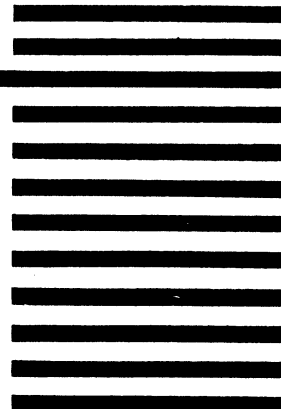

digital

DIGITAL EQUIPMENT CORPORATION, Corporate Headquarters: Maynard, Massachusetts 01754, Telephone: (617) 897-5111—SALES AND SERVICE OFFICES: UNITED STATES—ALABAMA, Huntsville • ARIZONA, Phoenix and Tucson • CALIFORNIA, El Segundo, Los Angeles, Oakland, Ridgecrest, San Diego, San Francisco (Mountain View), Santa Ana, Santa Clara, Stanford, Sunnyvale and Woodland Hills • COLORADO, Englewood • CONNECTICUT, Fairfield and Meriden • DISTRICT OF COLUMBIA, Washington (Lanham, MD) • FLORIDA, Ft. Lauderdale and Orlando • GEORGIA, Atlanta • HAWAII, Honolulu • ILLINOIS, Chicago (Rolling Meadows) • INDIANA, Indianapolis • IOWA, Bettendorf • KENTUCKY, Louisville • LOUISIANA, New Orleans (Metairie) • MARYLAND, Odenton • MASSACHUSETTS, Marlborough, Waltham and Westfield • MICHIGAN, Detroit (Farmington Hills) • MINNESOTA, Minneapolis • MISSOURI, Kansas City (Independence) and St. Louis • NEW HAMPSHIRE, Manchester • NEW JERSEY, Cherry Hill, Fairfield, Metuchen and Princeton • NEW MEXICO, Albuquerque • NEW YORK, Albany, Buffalo (Cheektowaga), Long Island (Huntington Station), Manhattan, Rochester and Syracuse • NORTH CAROLINA, Durham/Chapel Hill • OHIO, Cleveland (Euclid), Columbus and Dayton • OKLAHOMA, Tulsa • OREGON, Eugene and Portland • PENNSYLVANIA, Allentown, Philadelphia (Bluebell) and Pittsburgh • SOUTH CAROLINA, Columbia • TENNESSEE, Knoxville and Nashville • TEXAS, Austin, Dallas and Houston • UTAH, Salt Lake City • VIRGINIA, Richmond • WASHINGTON, Bellevue • WISCONSIN, Milwaukee (Brookfield) • INTERNATIONAL—ARGENTINA, Buenos Aires • AUSTRALIA, Adelaide, Brisbane, Canberra, Melbourne, Perth and Sydney • AUSTRIA, Vienna • BELGIUM, Brussels • BOLIVIA, La Paz • BRAZIL, Rio de Janeiro and Sao Paulo • CANADA, Calgary, Edmonton, Halifax, London, Montreal, Ottawa, Toronto, Vancouver and Winnipeg • CHILE, Santiago • DENMARK, Copenhagen • FINLAND, Helsinki • FRANCE, Grenoble and Paris • GERMANY, Berlin, Cologne, Frankfurt, Hamburg, Hannover, Munich and Stuttgart • HONG KONG • INDIA, Bombay • INDONESIA, Djakarta • IRELAND, Dublin • ITALY, Milan and Turin • JAPAN, Osaka and Tokyo • MALAYSIA, Kuala Lumpur • MEXICO, Mexico City • NETHERLANDS, Utrecht • NEW ZEALAND, Auckland • NORWAY, Oslo • PUERTO RICO, Santurce • SINGAPORE • SWEDEN, Gothenburg and Stockholm • SWITZERLAND, Geneva and Zurich • UNITED KINGDOM, Birmingham, Bristol, Edinburgh, Leeds, London, Manchester and Reading • VENEZUELA, Caracas •