

DECmate™ II

Owner's Manual

1st Edition, December 1982
2nd Edition, January 1984

Copyright © 1982, 1984 by Digital Equipment Corporation.
All Rights Reserved.
Printed in U.S.A.

The reproduction of this material, in part or whole, is strictly prohibited. For copy information, contact the Educational Services Department, Digital Equipment Corporation, Maynard, Massachusetts 01754.

The information in this document is subject to change without notice. Digital Equipment Corporation assumes no responsibility for any errors that may appear in this document.

This equipment has been certified to comply with the limits for a Class B computing device, pursuant to Subpart J of Part 15 of FCC Rules. Only peripherals (computer input/output devices, terminals, printers, etc.) certified to comply with the Class B limits may be attached to this computer. Operation with non-certified peripherals is likely to result in interference to radio and television reception.

CP/M is a registered trademark of Digital Research, Inc.

The following are trademarks of Digital Equipment Corporation, Maynard, Massachusetts.

digital	DECwriter	P/OS	UNIBUS
DEC	DIGITAL	Professional	VAX
DECmail	LA	Rainbow	VMS
DECmate	MASSBUS	RSTS	VT
DECnet	PDP	RSX	Work Processor
DECUS			

Contents

Preface

Part 1 Overview

1 Describing Your System

- General 1
- Basic System Components 2
- Options 16
- Printers 22
- Modems 25
- External Cables 26

Part 2 Getting Started

2 Preparing for Your DECmate II

- General 29
- Location 29
- Furniture 29
- Lighting 30
- Electrical Power 30
- Temperature 30
- Humidity 31
- Air Quality 31
- Storing Your DECmate II Supplies 31
- Caring for Your DECmate II 32

3 Attaching Options to Your System

- General 33
- Connecting the RX01/RX02 Subsystem Option 33
- Using the RX01/RX02 Subsystem Option 35
- Installing the Hard Disk Subsystem Option 36
- Using the Hard Disk Subsystem Option 38
- Connecting to a Printer 38
- Connecting to Another System 41

4 Keyboard

- General 47
- Connecting the Keyboard 47
- How the Keys Work 48
- The Four Key Groups 49
- Main Keyboard 51
- Editing Keypad 53
- Numeric Keypad 54
- Arrow Keypad 54
- Special Function Keys 54
- Keyboard Indicators 58

5 Diskettes

- General 61
- What Is a Diskette? 61
- What a Diskette Looks Like 63
- How to Handle Diskettes 64
- How to Insert a Diskette in a Drive 65
- Preventing Problems 67
- If You Find Problems 67

6 Turning On Your DECmate II

- General 69
- How to Turn On Your DECmate II 69
- User Selections 73

Part 3 Solving Problems

7 What to Do If Your DECmate II Doesn't Work

- General 77
- When to Call the HELP LINE at Once 78
- Power-Up Self-Test 79
- Routine Measures to Take First 86
- System Test Diskette 87
- Power Problems 93
- Diskette Problems 93
- Printer Problems 93
- DECmate II Repair Guide 93
- DIGITAL Service 95

Part 4 Accessories and Supplies

8 Accessories and Supplies

- General 97
- Ordering Information 103

A Specifications

Glossary

Index

Figures

- 1-1 Basic System Components 1
- 1-2 System Unit (Front) 3
- 1-3 System Unit (Rear) 3
- 1-4 Parts Related to Power 4
- 1-5 Connector Panel 5
- 1-6 Keyboard 6
- 1-7 Video Monitor (Front, Rear, Bottom) 7
- 1-8 System Unit Modules 8
- 1-9 System Board 9
- 1-10 Option Board Locations on System Board 10
- 1-11 System Board Internal Connectors 11
- 1-12 System Board Detachable Cables 11
- 1-13 Power Supply 13
- 1-14 RX50 Diskette Drive 14
- 1-15 Power Switch and Fan Assembly 15
- 1-16 Options 16
- 1-17 CP/M Board 17
- 1-18 RX01/RX02 Board 18
- 1-19 Second RX50 Diskette Drive 19
- 1-20 Hard Disk Board and Drive 20
- 1-21 Vertical Stand 21
- 1-22 Printers Supported by DECmate II 23
- 1-23 Serial Printer Switch 24
- 1-24 DIGITAL Modems 25
- 1-25 Cables 27
- 3-1 Connecting a Dual-Drive RX02 to DECmate II 34
- 3-2 Correct Use of 5-1/4 Inch System Diskette with
RX01/RX02 Option 35
- 3-3 Hard Disk Drive and Board Installed 37
- 3-4 Configurations with Serial Printer Switch 40
- 3-5 DIGITAL Modems 42
- 3-6 DF01 Modem Cabling 43
- 3-7 DF02 Modem Cabling 44
- 3-8 DF03 Modem Cabling 44
- 3-9 Communications Connection Using Short-Haul Modems 46
- 4-1 Keyboard 49
- 4-2 Cursor on Video Monitor Screen 49
- 4-3 Main Keyboard 50
- 4-4 Editing/Numeric Keypad 53

4-5	Arrow Keypad	54
4-6	Special Function Keys	55
4-7	Keyboard LEDs	58
5-1	RX50 Drive Door Designations	62
5-2	RX50 5-1/4 Inch Diskette	63
5-3	Labelling a Diskette	64
5-4	Opening a Diskette Drive Door	65
5-5	Orienting and Inserting a Diskette	66
6-1	Message for No Problem	70
6-2	Drive 0 (A) Error Message	71
6-3	Self-Test Error Message	72
7-1	Self-Test Message for No Problems	79
7-2	Self-Test Message for Wrong Diskette	80
7-3	Self-Test Message for Error (1)	81
7-4	Main Menu on System Test Diskette	88
7-5	System Test Selected	89
7-6	System Test Ready to Run	89
7-7	System Test Results Sample	90
7-8	Install New Option Test Display	91

Tables

3-1	Factory-Set Printer Baud Rates and Data Formats	39
7-1	Power-Up Self-Test Error Codes	82
7-2	Combined Power-Up Self-Test Error Codes	83
7-3	Power-Up Self-Test Problem Indicators	85
7-4	Printer-Related Problems	94

Preface

Learning about DECmate II

Anyone new to the world of computers has probably heard the terms *hardware* and *software*. They refer to two aspects of any computing system: the physical equipment (hardware) and the programs or routines (software) that the hardware runs.

To introduce you most easily to using the DECmate II, DIGITAL has prepared two kinds of manuals. The hardware manuals describe the mechanical, electrical, and electronic parts of a computer. Software manuals, sometimes called applications manuals, tell you how to apply the system programs to your particular needs.

This manual is a hardware manual. It is written for anyone who will work with a DECmate II.

Using DECmate II Documents and Media

Your DECmate II hardware system is shipped with the following documents and media:

- DECmate II Documentation Map
- DECmate II Installation Guide
- System overview diskette
- DECmate II Owner's Manual
- System test diskette

The *DECmate II Documentation Map* (EK-DM2DM-RC) is a one-page map that shows the order in which you should use the documents and media.

The *DECmate II Installation Guide* (EK-DECM2-IN) is a pictorial guide that shows the step-by-step procedures you need to install the DECmate II, its option boards, vertical floor stand, and extra RX50 diskette drive.

The system overview diskette (BL-P333A-BA) is shipped with the *DECmate II Installation Guide*. It is a computer-based course that you can take at your own pace. The course acquaints you with the hardware features of the DECmate II and allows you to practice using these features at the keyboard.

The *DECmate II Owner's Manual* (EK-DECM2-OM) is a resource and reference manual for your DECmate II hardware system. It acquaints you with the components, controls, and features of the DECmate II. It provides troubleshooting and service information and any special installation procedures required for its options.

The system test diskette (BL-T345A-MA) is shipped with the *DECmate II Owner's Manual*. It provides a hardware check of your DECmate II system when something does not function as it should. Chapter 7, "What to Do If Your DECmate II Doesn't Work," tells you how to use this diskette.

Other Documents

Each application software system has its own set of documents. Other available hardware manuals are as follows:

The *DECmate II Repair Guide* (EK-DECM2-AM) is another option offered by DIGITAL. You may purchase this pictorial guide if you want to service your DECmate II yourself. It provides procedures for troubleshooting and replacing the modules in the system unit.

A system test diskette (BL-T345A-MA) is shipped with the *DECmate II Repair Guide*. It provides an extensive system-level checkout with detailed diagnostics.

The *DECmate II Technical Description* (EK-DECM2-TD) is the hardware technical reference for DECmate II. It provides a system overview, detailed block diagram, and description of major components. It also includes programming information for controlling the video display by using escape codes.

Using This Document

The *DECmate II Owner's Manual* identifies the parts of your system, describes how to get started, and tells you what to do if you have problems. It is divided into the following four sections:

Overview

Chapter 1, "Describing Your System," introduces you to the DECmate II. It identifies the parts of the basic system and describes the options, printers, and modems supported by the DECmate II.

Getting Started

Chapter 2, "Preparing for Your DECmate II," recommends a suitable environment for your DECmate II and provides information on routine care.

Chapter 3, "Attaching Options to Your System," provides procedures for connecting an RX01 or RX02 diskette system, a hard disk drive, a printer, another computer, or a modem to your system.

Chapter 4, "Keyboard," describes the keys and indicators on your DECmate II.

Chapter 5, "Diskettes," describes the types, use, and care of diskettes.

Chapter 6, "Turning On Your DECmate II," describes how to turn on your DECmate II and what to expect at that time.

Solving Problems

Chapter 7, "What to Do If Your DECmate II Doesn't Work," provides simple troubleshooting procedures, tells you how to use the system test diskette, and describes DIGITAL services.

Accessories and Supplies

Chapter 8, "Accessories and Supplies," provides a list of items available through DIGITAL and tells how to order them.

The appendix provides a list of specifications for your DECmate II.

The glossary provides definitions of terms used in this manual that may be new to you.

The index provides a cross-reference to commonly used terms in this manual.

Part 1

Overview

Describing Your System

General

DECmate II is a small business computer that runs WPS word processing software and a variety of business applications.

Figure 1-1 shows the three main components of the DECmate II basic system: the system unit, the keyboard, and the video monitor. Within the system unit are more parts or modules that are functionally independent of the computer system. This design makes replacing parts easy.

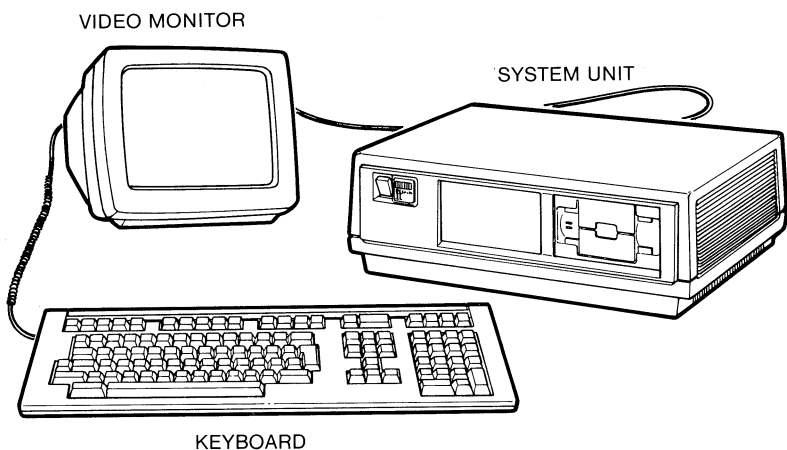

MA-10.298

Figure 1-1 Basic System Components

Hardware options allow the basic system to be tailored to serve individual requirements. For example, printers offer different types of letter quality and modems can be used at different transmission speeds. Printers provide a copy of your work printed on paper. Modems are small devices that allow two-way communications between computers over telephone lines.

NOTE: *Installation requirements for both modems and printers are described in Chapter 3.*

This chapter describes hardware items associated with the DECmate II. It identifies the basic system and its modules. It identifies the options and describes the printers and modems that DECmate II supports.

Basic System Components

The following paragraphs describe the basic system.

System Unit

The system unit is the part of DECmate II that controls the rest of the system, does the computing tasks, and stores information. It contains the system board, power supply, diskette drive, power switch and fan assembly, and option boards.

Figure 1-2 shows the front of the system unit. In the upper-left corner is a power switch. This switch turns your system on (1) and off (0). On the right of the system unit are the diskette drive doors. Two light emitting diodes (LEDs) glow whenever the drives are reading or writing to diskettes. A removable panel in the middle marks the place where an optional second diskette drive or a hard disk drive can be installed. The cover of the system unit is removable by means of latches beneath the overhanging areas on each side.

Figure 1-3 shows the rear of the system. In the upper-right corner are the parts related to the power your system uses. Along the bottom is the connector panel.

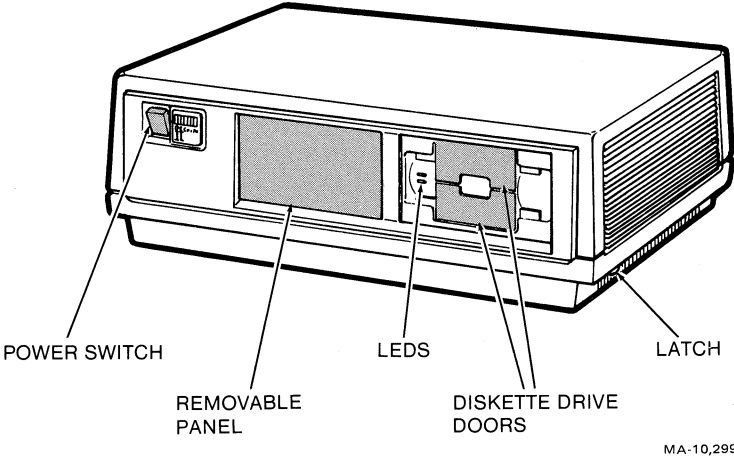

MA-10,299

Figure 1-2 System Unit (Front)

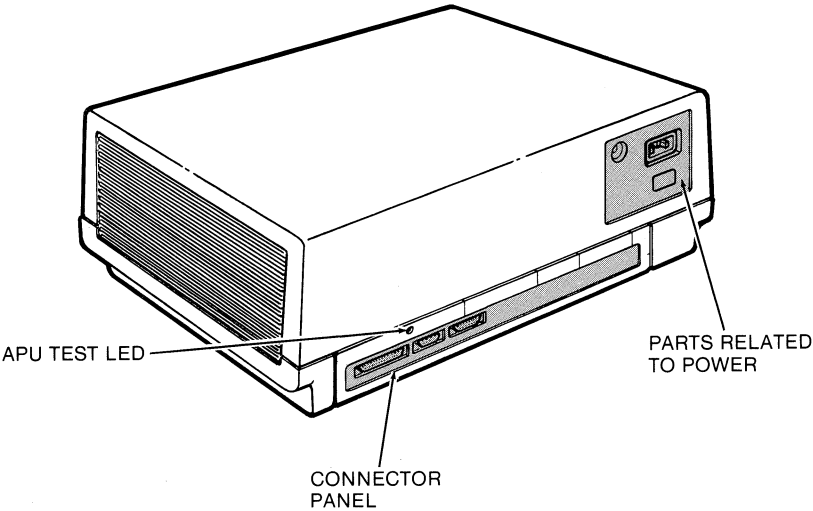

MA-10,300

Figure 1-3 System Unit (Rear)

Power Area

Figure 1-4 is a close-up of the parts related to power on the DECmate II.

Circuit Breaker. This recessed knob acts like a fuse to protect the system from electrical damage. It will pop out under overload conditions.

Power Cord Connector. The ac power cord plugs into this connector.

Voltage Selection Switch. This slide switch matches the system's voltage needs to the available voltage. Setting it determines whether your system will accept 115 volts or 230 volts. The switch is set for your required voltage before shipping and needs no further adjustment.

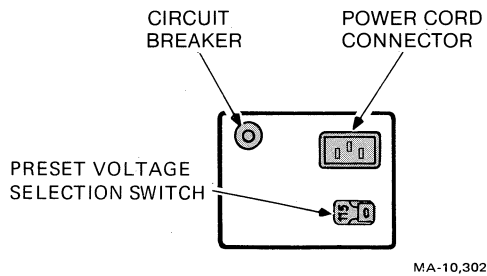

Figure 1-4 Parts Related to Power

Connector Panel

Figure 1-5 shows the parts of the connector panel.

Communications Connector. This 25-pin connector is used to connect the DECmate II with another computer. You can make this connection with a nearby computer, forming a hardwired connection, or with a remote computer via a modem. See Chapter 3 for information.

Printer Connector. This 9-pin connector is used to connect a printer to your DECmate II. See Chapter 3 for information.

Video Monitor Connector. This 15-pin connector is used to connect the video monitor to your DECmate II.

Removable Plastic Adapter Plate. This removable plate fills an opening in the connector panel. You will remove this plate if you install an optional hard disk drive or an RX01/RX02 board (used to connect an RX01 or RX02 external diskette drive to your DECmate II). See “Options” and “Cables” in this chapter for information.

APU Test LED. The auxiliary processor unit (APU) test LED flickers when the optional CP/M board performs a power-up self-test. If the test reveals a problem, the LED glows steadily.

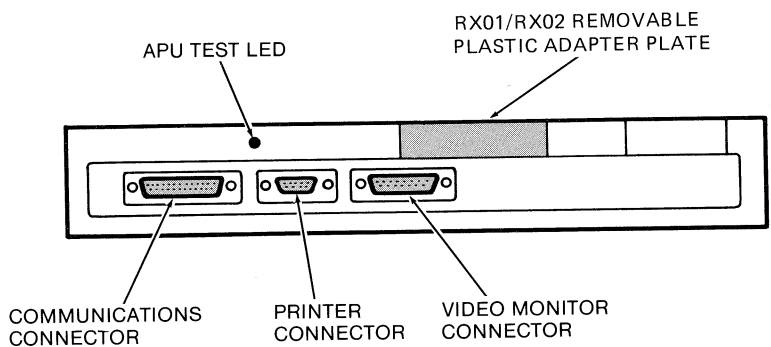

MA-10,301

Figure 1-5 Connector Panel

Keyboard

The keyboard (Figure 1-6) allows you to enter and edit information on your DECmate II. It has four groups of keys, a legend strip storage area, and four LEDs. A small speaker and electronic circuitry are inside. The keyboard transmits your input to the system indirectly through the video monitor via a coiled cable. See Chapter 4 for a description of the keys, LEDs, audible indicators, and cable placement.

Video Monitor

The adjustable tilt video monitor (Figure 1-7) is your window into the system. Its 31-centimeter (12-inch) diagonal, nonglare screen can display up to 24 lines. A carry handle is in a recess underneath the video monitor. The tilt screen pushbutton on the right side releases a post that drops to provide a 0 to 30 degree tilt range. On the rear of the video monitor are the keyboard and video monitor connectors and the brightness and contrast controls.

The contrast control adjusts the degree of contrast on your video monitor. At its lowest setting the characters blend into the background. The brightness switch controls the brightness on your video monitor screen.

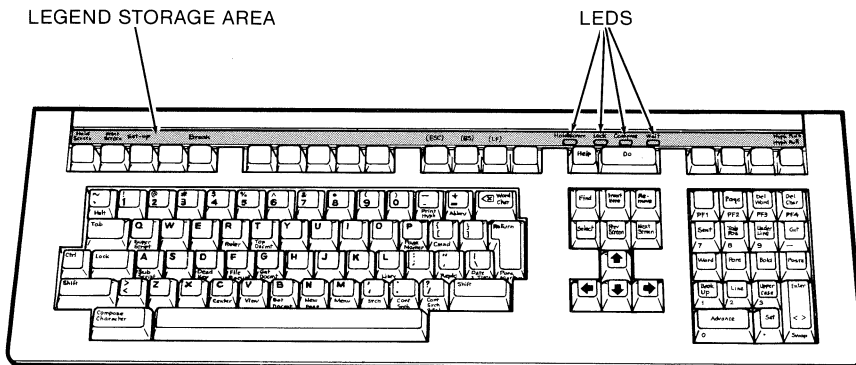

MA-10,303A

Figure 1-6 Keyboard

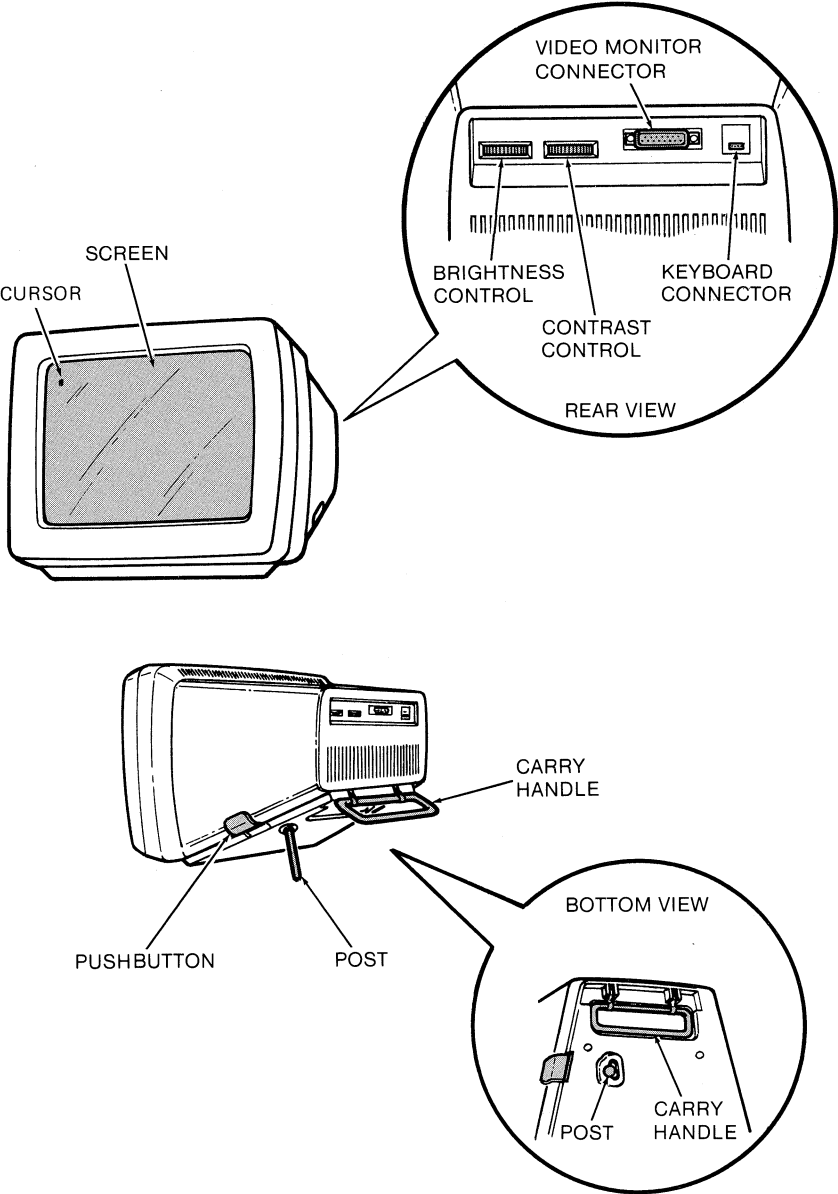

MA-10,304

Figure 1-7 Video Monitor (Front, Rear, Bottom)

System Unit Modules

The system unit is designed so that you can replace its functional parts. These parts (Figure 1-8) are called *modules* and consist of the system board, power supply, and an RX50 diskette drive. Some option modules, such as a second diskette drive or a hard disk drive, can be housed in this unit. The system unit also contains a power switch and fan assembly. The following paragraphs describe the standard system unit modules.

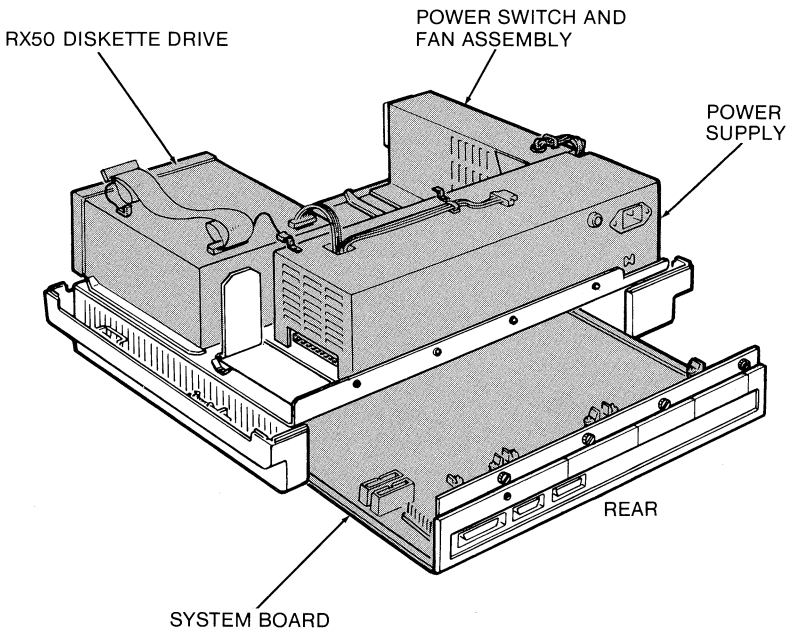

MA-10,305

Figure 1-8 System Unit Modules

System Board

The system board (Figure 1-9) is the “brain” of your system. It contains the central processing unit (CPU) and the electronic circuits that control the rest of the DECmate II system. The system board, directed by the CPU, controls the flow of information to and from the video monitor, the keyboard, the diskette drive, and all the external items connected to your system.

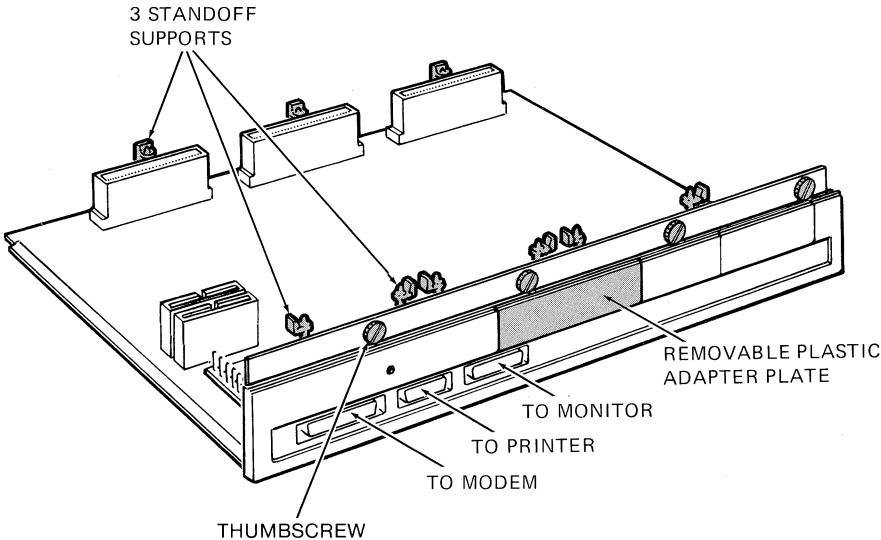

MA-10,306

Figure 1-9 System Board

The system board lies horizontally along the bottom of the system unit. When released, the board slides straight out. Standoff supports on the system board hold any option boards you may install. Figure 1-10 shows the option board locations.

Figure 1-11 shows the system board connectors. The connectors allow power and information to flow among the modules via cables. A wide, flat power cable connects the system board to the power supply. A thinner data cable links the system board to the RX50 diskette drive. Another data cable links the system board to an optional RX50 drive. Three connectors on the rear edge of the system board provide the external connections to communications, printer, and video monitor cables.

Figure 1-12 shows the cables inside the system unit.

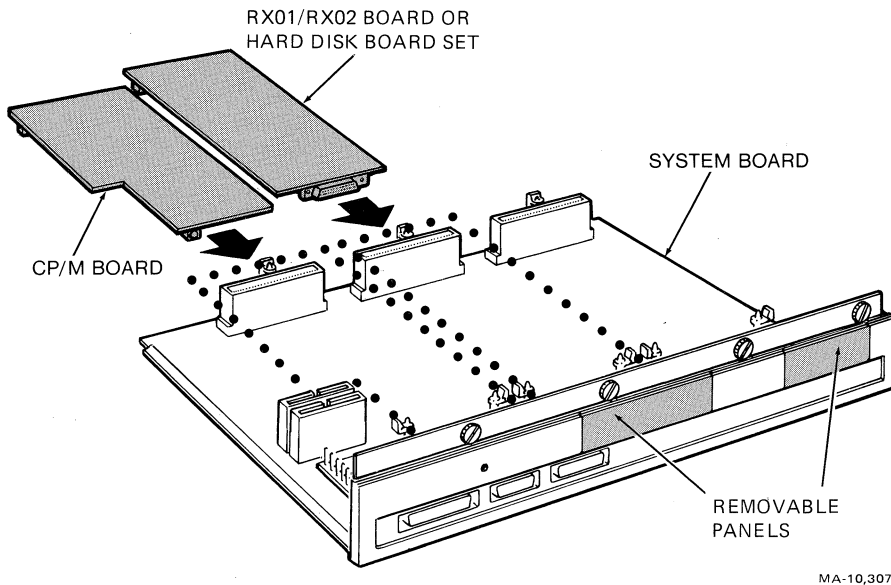
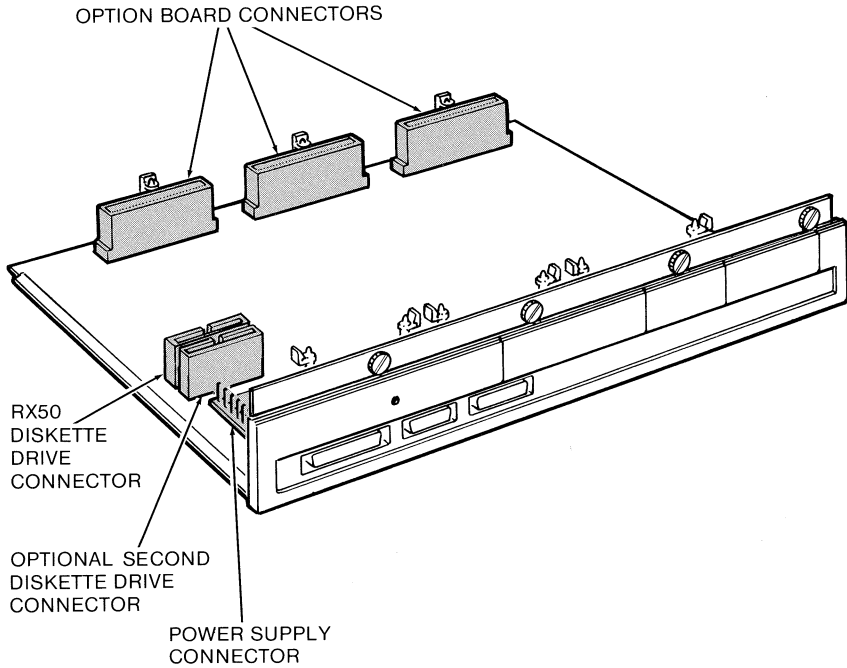
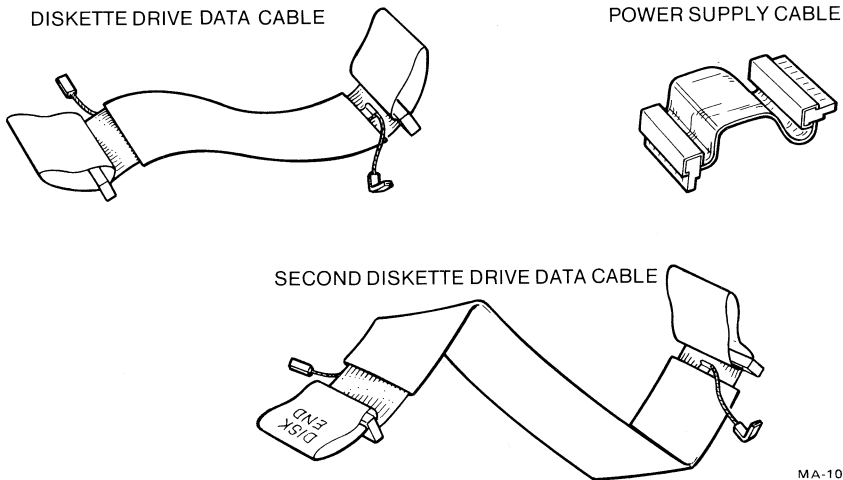

Figure 1-10 Option Board Locations on System Board



MA-10,308

Figure 1-11 System Board Internal Connectors



MA-10,309

Figure 1-12 System Board Detachable Cables

Power Supply

The 135-watt power supply (Figure 1-13) supports the system unit modules, keyboard, and video monitor. The power supply is necessary in any system because it converts the alternating current (ac) that comes from the standard wall outlet into a current your system can use, direct current (dc).

NOTE: *If you are uncertain about the power supplied in your location, refer to the appendix for a description of power ranges acceptable to DECmate II.*

There are five connections on the power supply. Two cables permanently attached to the power switch and fan assembly connect to the power supply via two detachable connectors. These two power cables must be unplugged before you can remove the power supply. The 13-pin flat cable, detachable from both ends, must also be unplugged from the system board before you can remove the power supply. Two 4-pin connectors, permanently attached to the power supply, provide power to each RX50 diskette drive.

The power supply is released from the system unit by moving a slide tab at the end.

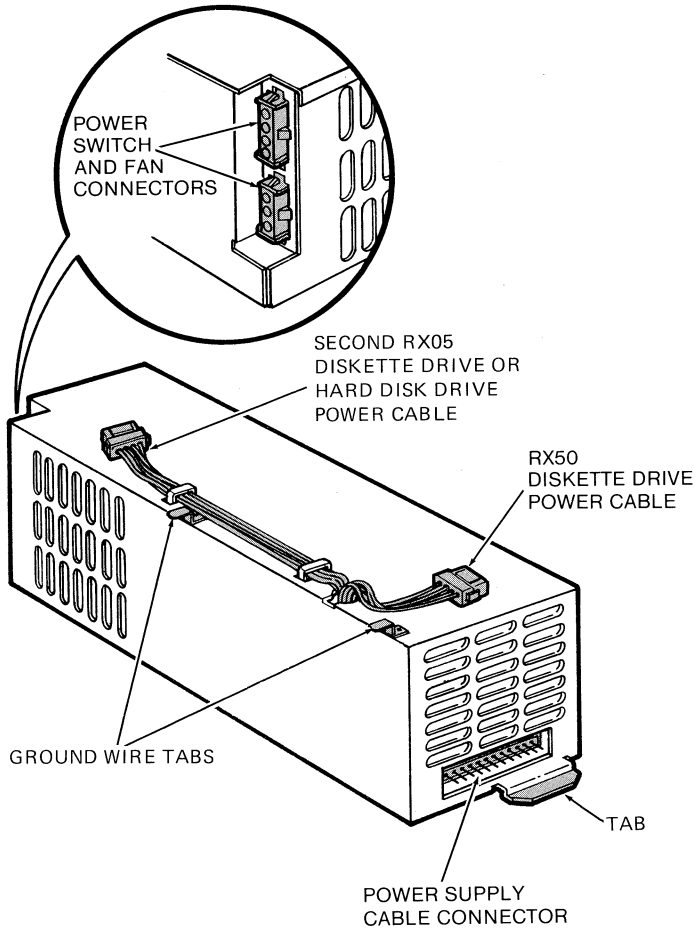

MA-10,310

Figure 1-13 Power Supply

RX50 Diskette Drive

The RX50 diskette drive is the part of the DECmate II that allows the system to use the information on diskettes. Diskettes, described in Chapter 5, contain the programs that run your DECmate II applications as well as your own work.

Figure 1-14 shows the RX50 diskette drive. It is a dual drive because it can use two diskettes at the same time. Its two doors show through the cover of the system unit. Two small LEDs glow whenever the drive is reading or writing to a diskette. They serve as a warning not to open the doors during those times. See Chapter 5 for information on diskettes.

You can remove the diskette drive by pressing a tab at the front of the system unit. The drive slides forward along its tracks and out.

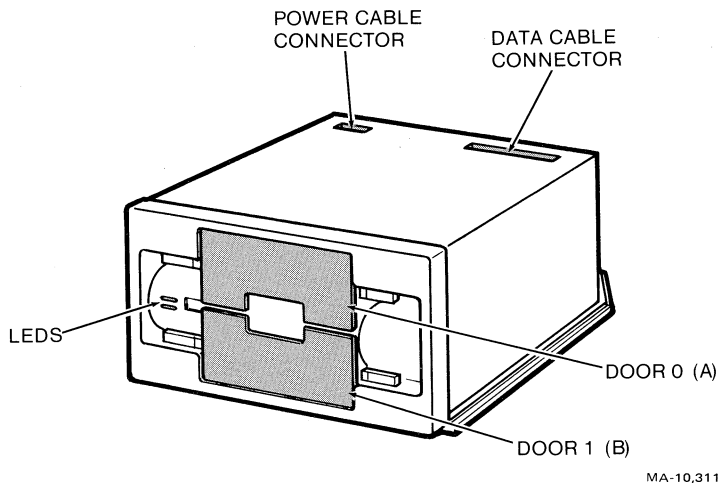
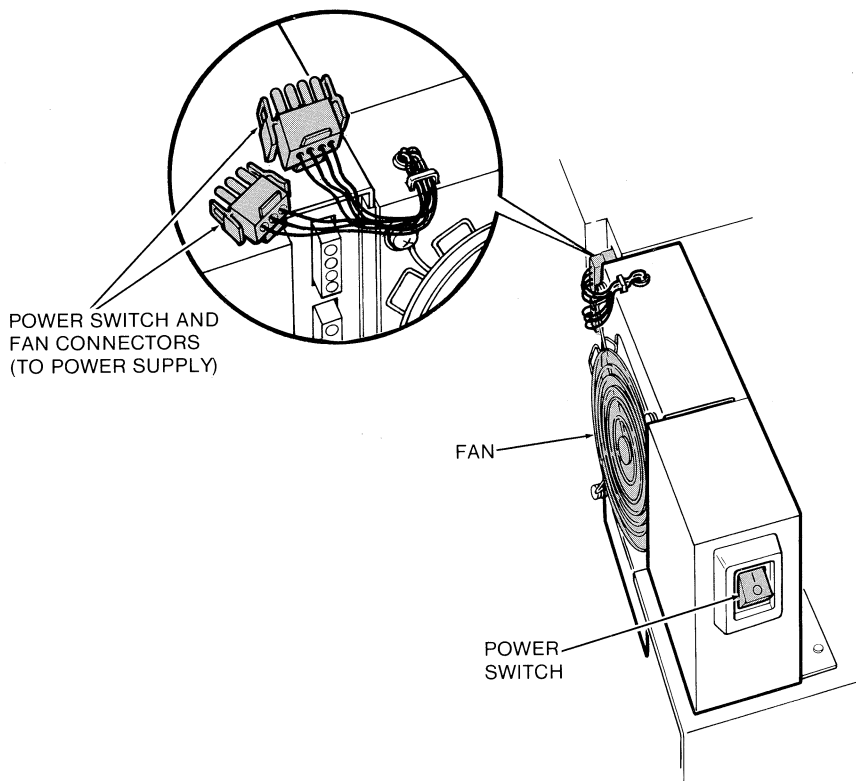

Figure 1-14 RX50 Diskette Drive

Power Switch and Fan Assembly

WARNING: High voltages in the power switch and fan assembly can cause injury. Do not try to remove it without a DIGITAL service representative or instructions from the DECmate II Repair Guide.

The power switch (Figure 1-15) turns your system on and off. The fan provides a flow of air essential to the control of the internal temperature. Two cables plug into the power supply to receive operating power.



MA-10,312

Figure 1-15 Power Switch and Fan Assembly

Options

Options add functional capabilities to the DECmate II basic system. Figure 1-16 shows the following options that are available for DECmate II:

- CP/M board
- RX01/RX02 board
- Second RX50 diskette drive
- Hard disk drive subsystem
- Vertical floor stand

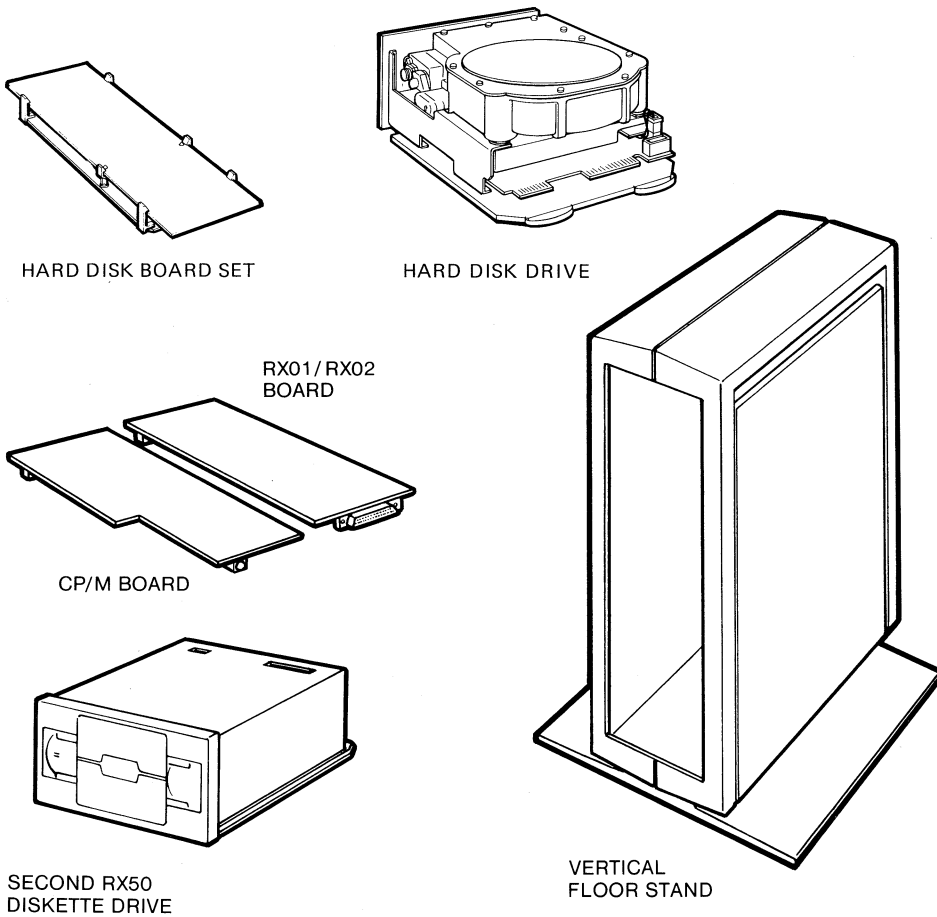

MA-10,316

Figure 1-16 Options

CP/M Board

This small printed circuit board (Figure 1-17), also known as the APU, allows you to use CP/M software. You mount it face down on the system board and join the connectors on each board. Three standoff supports hold the board in place.

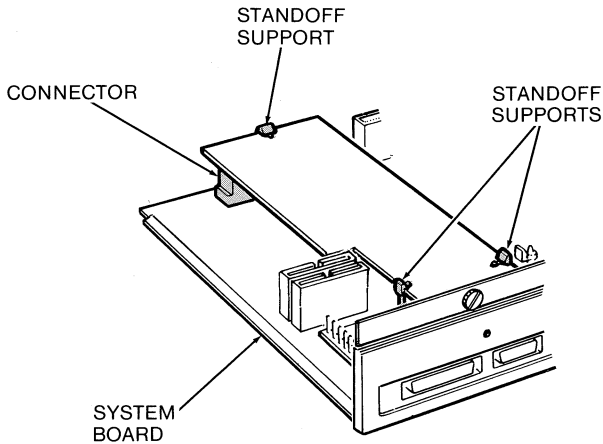

MA-10,313

Figure 1-17 CP/M Board

RX01/RX02 Board

This small printed circuit board (Figure 1-18) transfers information between an 8-inch RX01 or RX02 diskette drive and the system. This board is activated when you load your operating system software into the system.

Mount this board face down on the system board and join the connectors on each board. Three standoff supports hold the board in place. The external connector on the front edge of this board fits through a slot in the system board panel. When installing this board, you must replace the plastic adapter plate in the panel with the plastic insert plate shipped with the board. See Chapter 3 for information.

NOTE: When inserting an option board, be sure to place it under the lip at the rear of the system unit before securing it with the standoff supports.

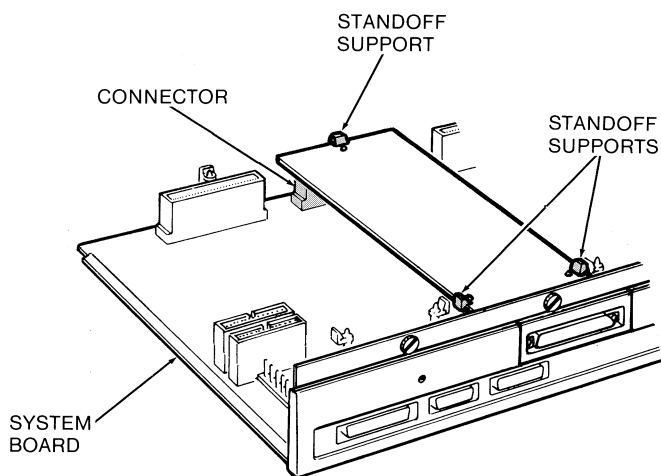

MA-10,314

Figure 1-18 RX01/RX02 Board

Second RX50 Diskette Drive

A second diskette drive increases the system's storage capacity to 1.6 megabytes. It mounts next to the standard diskette drive in the system unit. Before installing it, you must remove the panel in the front of the system unit cover. Figure 1-19 shows this drive mounted in the system unit.

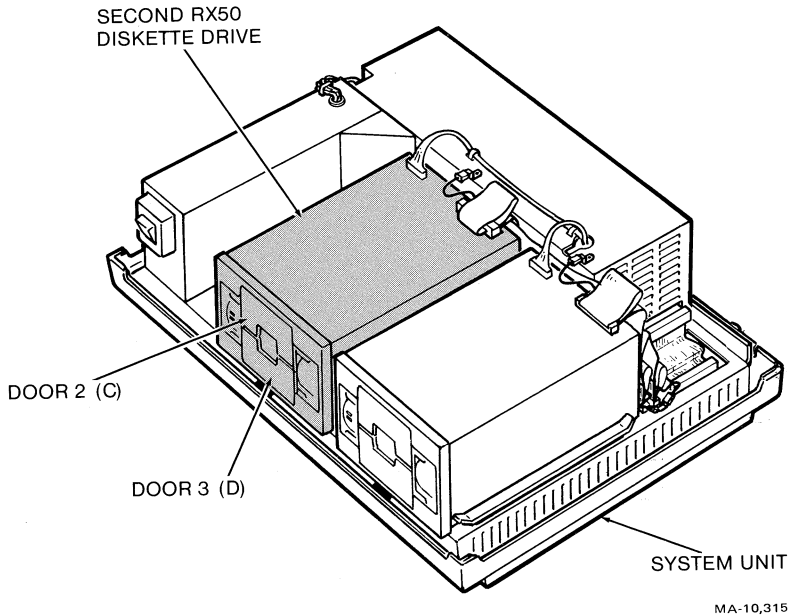
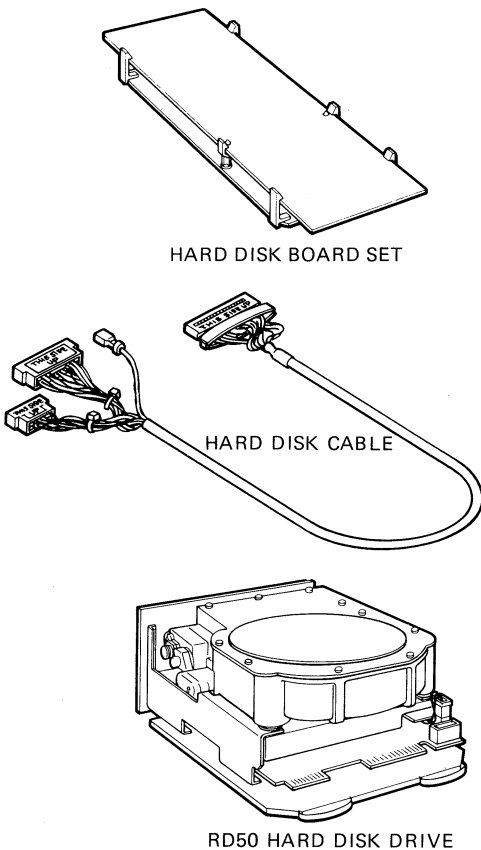

Figure 1-19 Second RX50 Diskette Drive

Hard Disk Drive Subsystem

A hard disk drive allows you to store 10 megabytes of software on permanently sealed disks and save the diskette with application programs for occasional use as a backup. Once you have loaded an application onto your hard disk, you can access it immediately without reloading the diskette. Figure 1-20 shows the hard disk drive mounted in the system unit. Notice that the hard disk board is actually a set of two boards fastened together. The hard disk cable has a single connector on one end that plugs into the hard disk board set. On the other end are three connectors that go to the hard disk drive plus the ground wire.



MA-1144-83

Figure 1-20 Hard Disk Board and Drive

Vertical Floor Stand

This stand (Figure 1-21) allows you to use and store your system unit in an upright position. The system unit inserts into the rear of the stand through a hinged door. Notches in the top and bottom of the door allow the system cables to extend safely in a convenient direction.

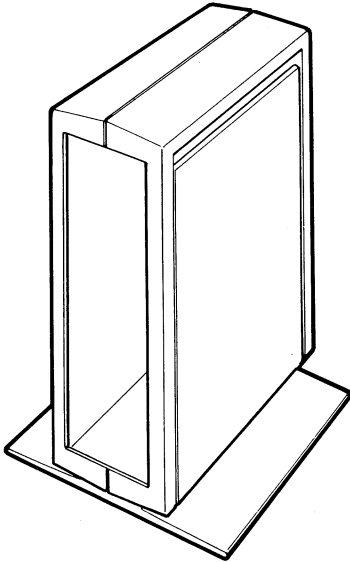

MA-10,208

Figure 1-21 Vertical Stand

Printers

A printer gives you copies of your work on paper. The printer connects to the DECmate II via the printer connector in the rear panel of the system unit.

Using printers sometimes requires adjusting the rate of transmission of information (baud rate) from the system unit to the printer. See Chapter 3 for information on using your printer with DECmate II.

DECmate II supports the three printers shown in Figure 1-22.

LA50 Printer

The LA50 is a compact dot matrix printer that uses an impact printhead. It provides three printing modes: text mode at 100 characters per second, enhanced mode at 50 characters per second, and a bit map graphics mode.

LA100 Printer

The LA100 is a high-resolution dot matrix printer. It has plug-in font cartridges that provide a variety of fonts (Courier, Gothic, etc.). It provides three printing modes: high speed/low density draft quality mode, letter quality mode, and a bit map graphics mode.

LQP02 Printer

The LQP02 is a full-character impact printer that produces high-quality print. It uses a changeable daisy print wheel to provide a variety of fonts. It can print on regular office stationery as well as fanfold paper.

Automatic Sheet Feeder

This sheet feeder (Figure 1-22) automatically feeds precut forms from selectable trays to the LQP02 printer. The feeder can hold two supplies of paper and one supply of envelopes. After being printed, the sheets are fed into the output hopper where they are collated.

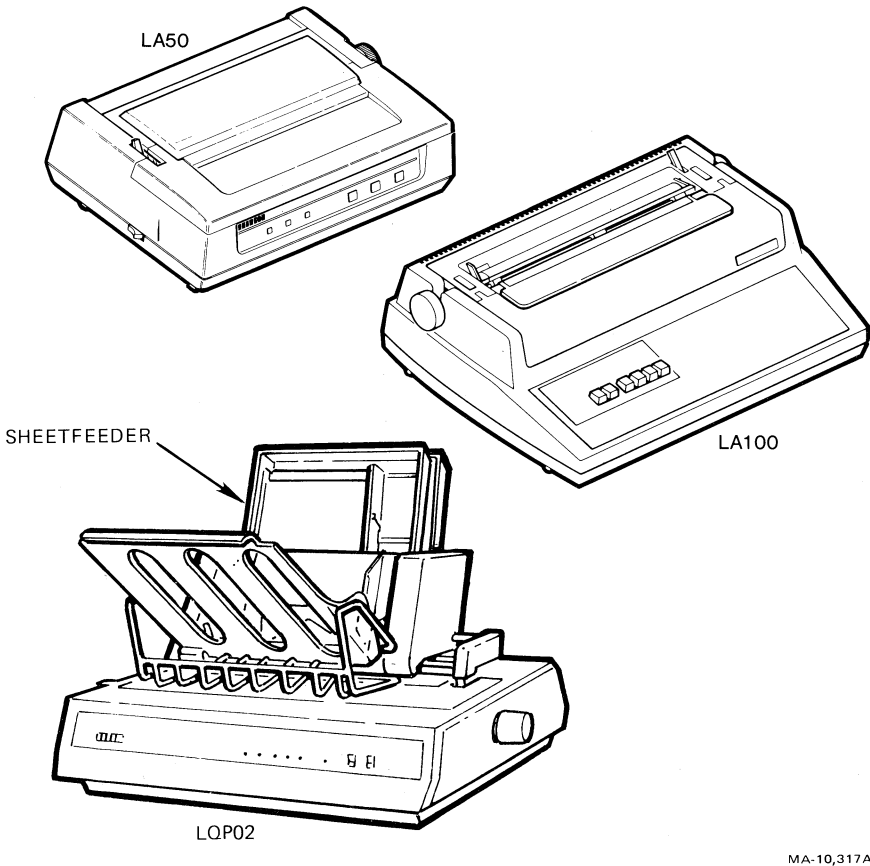

MA-10,317A

Figure 1-22 Printers Supported by DECmate II

Serial Printer Switch

This switch (Figure 1-23) allows two systems to share a printer, or one system to use two printers. The cables needed and the ways to connect these devices are shown in Chapter 3.

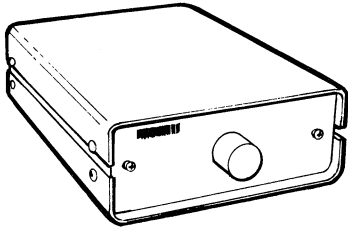

MA-1142-83

Figure 1-23 Serial Printer Switch

Modems

The DECmate II can be connected to communicate with another computer. When the other computer is close enough, the connection requires only a cable. For longer distances, the two computers can use the telephone lines.

A modem is a small box that allows your computer to send and receive information to and from another computer over telephone lines. Named for its function, *modulator-demodulator*, it converts electric pulses from the computer into audio tones that the telephone can send and receive.

DECmate II supports three DIGITAL modems and a series of Bell System and Bell System-compatible modems listed in Chapter 3. DIGITAL modems DF01, DF02, and DF03 are shown in Figure 1-24.

See Chapter 3 for information on how to set up your DECmate II to communicate with another computer.

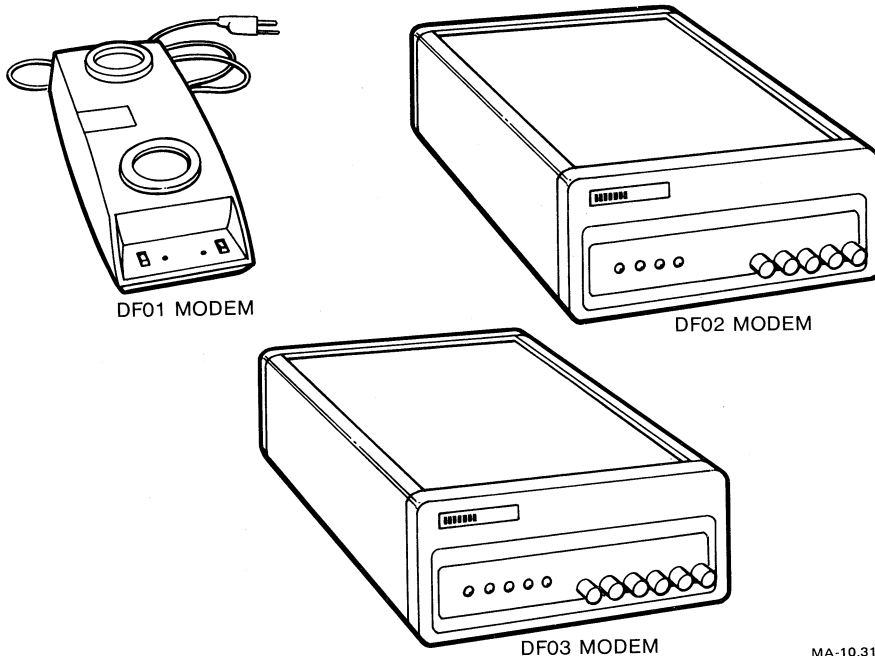

MA-10,318

Figure 1-24 DIGITAL Modems

External Cables

The DECmate II basic system comes with two external cables and a power cord. The variety of applications to which you can put your DECmate II may require other cables as well.

Figure 1-25 shows the power cord and other cables for the DECmate II, and the following paragraphs describe them.

Power Cord

The 2-meter (6-foot) power cord carries ac power into your system. It is shipped with the keyboard and fits an outlet that supplies either 115 volts or 230 volts.

NOTE: *Never plug the DECmate II into a wall outlet with the power switch on (1).*

Video Monitor Cable

This 2-meter (6-foot) cable is shipped with the system unit. It connects the video monitor to the system unit. It carries power to the video monitor and command, status, or data signals between the system unit and video monitor.

Keyboard Cable

This 2-meter (6-foot) coiled cable is shipped with your keyboard. It connects the keyboard to the video monitor. It carries power to the keyboard and command, status, or data signals that travel between the CPU and the keyboard via the video monitor.

This cable has a telephone-style connector at each end. The longer end of uncoiled cord goes into the underside of the keyboard. The cord can be routed in the narrow groove to extend from either the right or left side of the keyboard.

BASIC SYSTEM CABLES

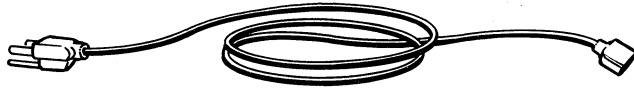

POWER CORD (U.S.A.)

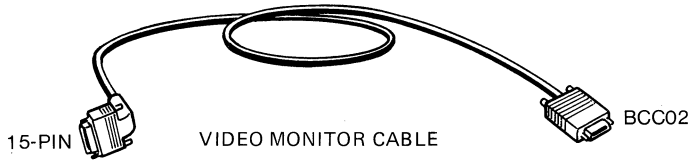

15-PIN

VIDEO MONITOR CABLE

BCC02

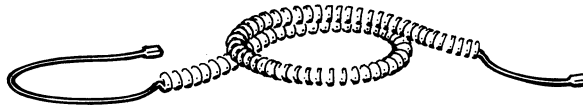

KEYBOARD CABLE

OPTIONAL CABLES

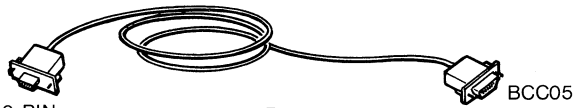

9-PIN

PRINTER CABLE

BCC05

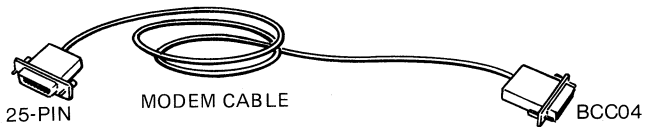

25-PIN

MODEM CABLE

BCC04

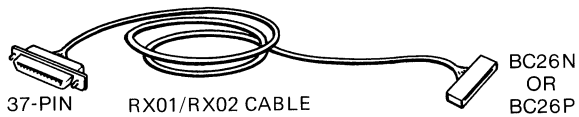

37-PIN

RX01/RX02 CABLE

BC26N
OR
BC26P

MA-10,217

Figure 1-25 Cables

Communications Cables

Your DECmate II can communicate with another computer via a cable directly attached to that computer. This connection is *hardwired* and requires a BC03M cable. When communicating over a telephone line by using a modem, the DECmate II requires the following cables:

Modem DF01 – Use the cable shipped with your modem.

Modem DF02 – Use a BCC04 cable.

Modem DF03 – Use a BCC04 cable.

NOTE: *The BCC04 cable is also used with the serial printer switch.*

Printer Cable

This cable connects the printer to your DECmate II system. The required printer cables are as follows:

LA50 – Use a BCC05 cable.

LA100 – Use a BCC05 cable.

LQP02 – Use a BCC05 cable.

RX01/RX02 Cable

This cable allows you to attach an RX01 or RX02 diskette drive to your DECmate II. You can use the cable you are currently using with your RX01 or RX02 diskette drive unit. It should be marked BC26N or BC26P.

NOTE: *If your RX01/RX02 is rack mounted, you can make the cabling compatible by installing an enclosure kit (SRXEN-00).*

Part 2

Getting Started

2

Preparing for Your DECmate II

General

The design of the DECmate II normally poses few constraints on selecting a place for it. Nevertheless, location, cleanliness, temperature, humidity, and the quality of electrical power can affect the reliability of your system. Use the following guidelines to ensure a good environment for operating the DECmate II, storing its supplies, and caring for your system.

Location

Allow for about 15 centimeters (6 inches) of air flow around the system unit and video monitor. Ventilation openings prevent your system from overheating. Do not block the openings with objects or walls. Make sure liquids, coins, paper clips, and other objects cannot fall into the openings.

Plan the space for your printer, modem, and other devices that have cables. Cables should be well out of traffic areas.

Furniture

The only restriction on what furniture you use to hold your system is the 2-meter (6-foot) cable that connects your monitor to the system unit. You can use a typewriter stand, standard desk, or work table for any of the three basic system components. The optional vertical stand allows you to keep the system unit convenient to your working space.

Lighting

The video monitor has a nonglare screen. However, direct sunlight can cause glare and may overheat the system.

Electrical Power

Your DECmate II system is designed to operate on the power that normally comes into your building. Because power fluctuations can cause system errors, you should try to reduce the chance of power fluctuations in these ways:

- Do not connect devices that have a large motor to the same line for your DECmate II, including copiers, typewriters, or electric pencil sharpeners.
- Do not use an electrical outlet where you know the power fluctuates. An indication of fluctuating power is when you see a light dim for no apparent reason.

Temperature

DECmate II is made to operate in an air temperature of 15° to 32° C (59° to 90° F). Rapid changes or extremes in temperature can affect the system. Do not operate the system near heat registers, air conditioners, or large windows.

Humidity

DECmate II is made to operate in a relative humidity of 40% to 60%. Too much or too little moisture in the air can affect the system. Low humidity, for example, can induce static electricity. This condition produces a shock or spark when you walk up to the machine and touch it. Static electricity can damage the system components or distort the magnetic patterns on your diskettes and cause errors.

Air Quality

DECmate II works best in clean, filtered air. Dust can clog the system's air passages, reducing the cooling efficiency of the fan system. Microscopic dust particles can also damage the surfaces of diskettes and cause errors.

Storing Your DECmate II Supplies

The supplies – paper, diskettes, and printer-related equipment – should be stored in an environment similar to that recommended for the DECmate II system.

- Keep paper and diskettes within the humidity range.
- Keep diskettes away from magnetic fields such as power sources and fluorescent lights.
- Store diskettes in dust-proof containers.
- Store backup copies of your diskettes away from your computer site in a proper environment.

Caring for Your DECmate II

A good environment as described earlier will help keep your DECmate II in working order. Its external surfaces require little upkeep. If you wish to clean its surfaces, use a small amount of soap or a mild detergent on a damp cloth. Never use a spray or cleaning solvent.

CAUTION: *Always turn off (0) the power switch before cleaning any surface.*

System Unit

- Do not allow liquids to fall through any of the air vents.
- Rub the unit cover with a moist cloth to keep it clean. Avoid using excessive water.
- Do not use the top of the unit as a stand for other objects.
- Keep the air vents away from walls and air-obstructing surfaces to prevent internal heat buildup.
- Never move the system unit while it is operating.

Video Monitor

- Clean the surface of the screen with a cloth. Moisten the cloth with the spray cleaner packed with the monitor. You can substitute alcohol or water for the spray cleaner.

Keyboard

- Leave the keycaps in place to clean them. Removing them can damage the switch contacts.

Attaching Options to Your System

General

Using options with the DECmate II sometimes requires special installation procedures. For example, after connecting a printer or modem, you may still need to adjust its baud rate, a process explained later in this chapter. This chapter contains the special procedures for using external equipment with your DECmate II. It describes using the RX01/RX02 subsystem option, installing the hard disk subsystem option, connecting printers, using the serial printer switch option, and connecting your DECmate II system to another computer with and without a modem.

Connecting the RX01/RX02 Subsystem Option

The following procedure requires that you replace a plastic adapter plate on the system unit rear panel, install the RX01/RX02 board, and connect a data cable. The board is activated when your operating system software is loaded into DECmate II memory.

1. Install the RX01/RX02 board on the system board. Follow the procedure in the *DECmate II RX01/RX02 Board Installation Guide*.

2. Locate the RX01 or RX02 data cable. One end is labelled **TERMINAL**; the other is labelled with one of the following numbers:

BC26N-10 (dual-drive interface cable)
BC26N-2L (dual-drive interface cable)
BC26P-YB (quad-drive interface cable)
3. Connect the **TERMINAL** plug to the RX01/RX02 connector on the system unit panel. Connect the other end(s) to the interface connector on the RX01 or RX02 diskette drive(s). Figure 3-1 is an example of how to connect a dual-drive RX02 to a DECmate II.

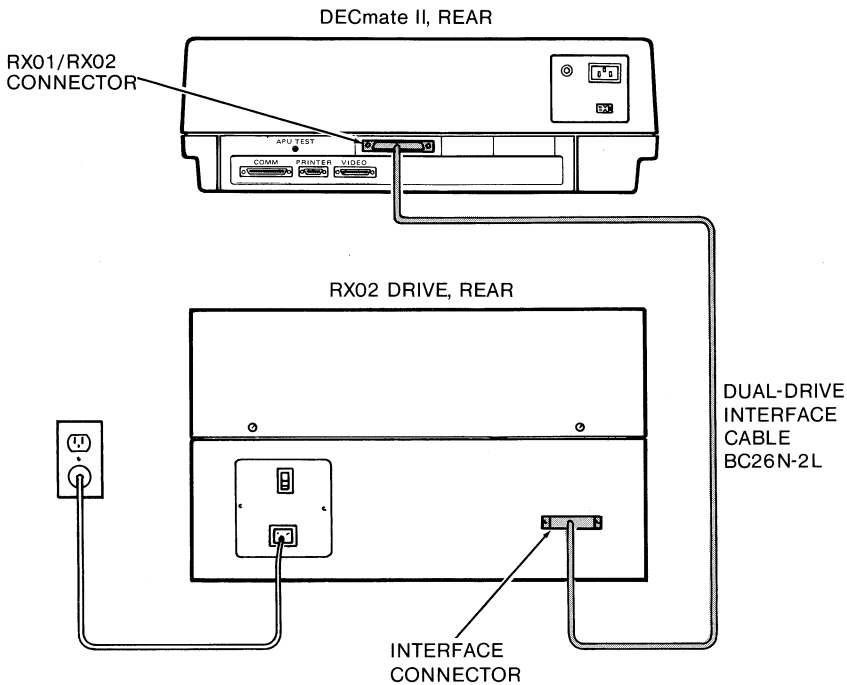

MA-10,320

Figure 3-1 Connecting a Dual-Drive RX02 to DECmate II

Using the RX01/RX02 Subsystem Option

Your application software controls the transfer of data between the external RX01 or RX02 8-inch diskettes and the system. You can edit data on the 8-inch diskettes as well as transfer the data to another diskette.

Figure 3-2 shows the correct placement of your system diskette. Note the following rules governing the system diskette:

- Use only the DECmate II 5-1/4 inch system diskette. You can, however, use the 8-inch system diskette as a document or data diskette.
- Place the 5-1/4 inch system diskette in drive 0 in your DECmate II. This option will not function with the system diskette in drive 1(B).

CAUTION: Do not try to use your current 8-inch system diskette when using this option.

NOTE: You can run standard format 8-inch CP/M diskettes with the addition of the CP/M board option along with the RX01/RX02 board option.

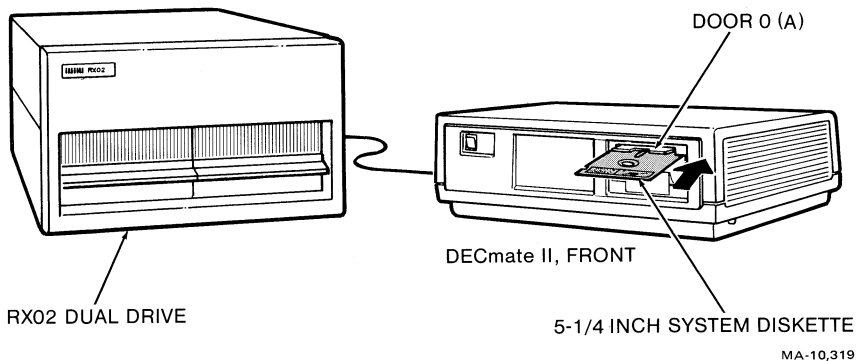

Figure 3-2 Correct Use of 5-1/4 Inch System Diskette with RX01/RX02 Option

Installing the Hard Disk Subsystem Option

The hard disk subsystem is made of two modules: the hard disk board set and the hard disk drive. The board set contains two boards that are fastened together before shipment. It is installed on the system board like a single board. Figure 3-3 shows the board set and the drive installed in the system unit.

1. Install the hard disk board set on the system board. Follow the procedure in the *DECmate II Hard Disk Subsystem Installation Guide* (EK-DM2HD-IN).
2. Install the hard disk drive in the system unit. Follow the procedure in the *DECmate II Hard Disk Subsystem Installation Guide*.
3. Format the hard disk by using the new system test diskette shipped with the hard disk subsystem documentation. Select `Format hard disk drive` from the menu on the system test diskette. Formatting prepares the surface of the disk to accept and store data. This must always be done to a new disk.
4. Test the hard disk subsystem by selecting `Run system test` on the menu. If `System Read Error` appears on the screen, the diskette is bad. If any of the following messages appear, the drive is defective and needs to be replaced.

```
Winchester Read Error
Winchester Write Error
Data Comparison Error
Winchester Format Error
Too Many Bad Blocks on the Hard Disk
```

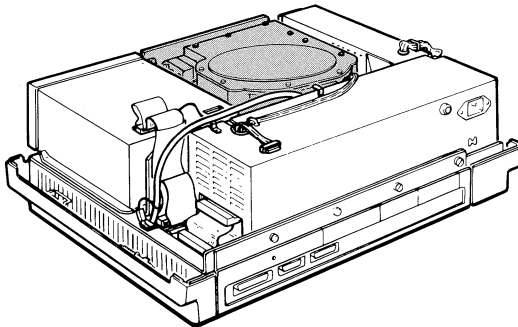
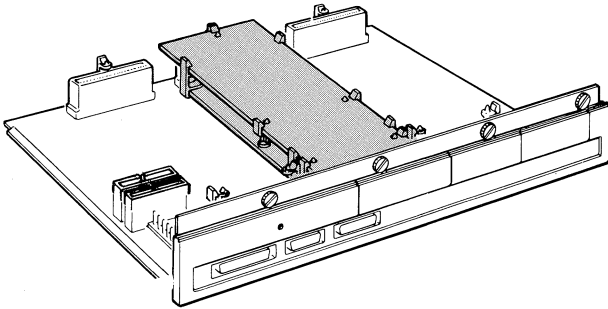

MA-1143-83

Figure 3-3 Hard Disk Drive and Board Installed

Using the Hard Disk Subsystem Option

You can copy application software from diskettes onto the nonremovable, permanently sealed, hard disk for storage. Consult your application software documentation for the procedure.

Connecting to a Printer

The user guides shipped with the LA50, LA100, and LQP02 printers provide installation and operation procedures. Follow the instructions provided and note the following information.

NOTE: *Always turn on your printer before turning on your system.*

Cables

Use a BCC05 printer cable for your LA50, LA100, or LQP02 printer. Do not use any other.

Baud Rate

The internal systems of the DECmate II and the printer need to know at what baud rate the signals will travel. The information that travels between a printer and the DECmate II travels at a unit of signal speed known as a *baud*. Because of the several ways you can use printers, the baud rate is adjustable on printers and your DECmate II.

For successful data transmission, the receive rate has to be equal to the transmit rate. The baud rate settings on the DECmate II and the printer need to be the same.

NOTE: *For your convenience, DIGITAL has preset these settings to be the same.*

Table 3-1 lists the baud rates your equipment has been set to at the factory.

Table 3-1 Factory-Set Printer Baud Rates and Data Formats

Device	Parity	Data Elements	Stop Bit	Baud Rate
DECmate II	No	8	1	4800
LA50 printer	No	8	1	4800
LA100 printer	No	8	1	4800
LQP02 printer	No	8	1	4800

To adjust the baud rate setting of DECmate II (a process of pressing keys), use the SET-UP procedures in the application software manuals. To adjust the baud rate setting of your printer (a process of setting switches on your printer), use the procedures in your printer manual.

Data Format

The information that travels between a printer and the DECmate II is processed as *bits*, the smallest unit of information your system recognizes. Bits are processed in patterns, and data format is the term used to describe the patterns.

Data format consists of parity, data elements, and stop bits. The printer and DECmate II need to know and agree on the data format. If there is a difference, they must be adjusted.

NOTE: For your convenience, DIGITAL has preset these settings to be the same.

Table 3-1 shows the data format your equipment has been set to at the factory.

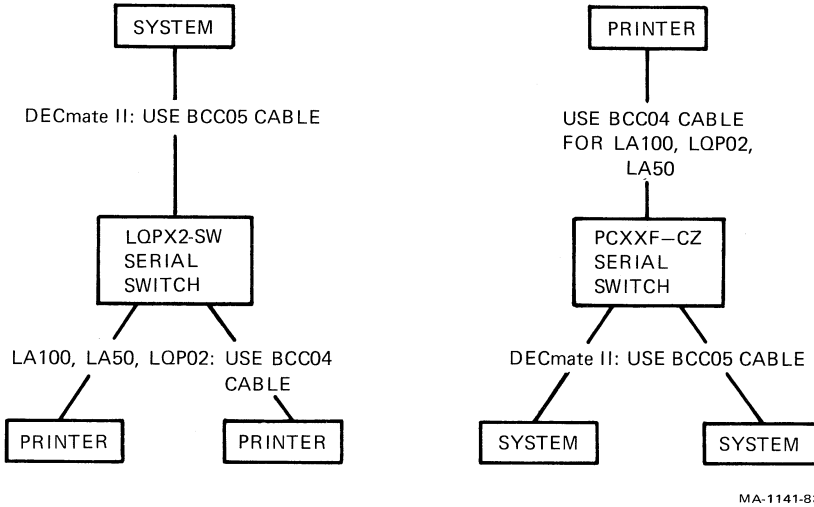

Figure 3-4 Configurations with Serial Printer Switch

Serial Printer Switch Option

The serial printer switch (two models) makes it possible for two systems to use one printer (PCXXF-CZ) or to attach two printers to one system (LQPX2-SW). Figure 3-4 shows the two configurations with the switch and cables needed for each.

Other Adjustments

Printers can also be adjusted in other ways. You can find information for the following printers under these headings:

- Installing and Using the LA50 Printer, "Printer Configuration"
- Letterprinter 100 Operator Guide, "Operator-Selectable Features"
- Installing and Using the LQP02 Printer, "System Configuration"

Connecting to Another System

Your DECmate II can be connected to another system in one of three ways:

- Using dial-up telephone lines
- Hardwiring your system
- Using leased or private lines

When you use any of these ways to connect your DECmate II to another system, you must make sure the baud rates and data formats are compatible between the sending and receiving systems. See “Connecting to a Printer” in this chapter for definitions.

Using Dial-Up Telephone Lines

Two DECmate II systems or a DECmate II and a host computer can be connected over telephone lines. To connect systems by this method requires the use of modems.

Modems. Modems are small devices that allow your system to communicate with another system by using the telephone lines. For originating and receiving calls on both sides of a communications link, you need modems at both ends.

Figure 3-5 shows three DIGITAL modems that are supported by the DECmate II. The DF03 is a direct-connect modem and supports 300 or 1200 bits per second. The DF02, also a direct-connect modem, supports 300 bits per second. The DF01 is an originate-only acoustic coupler and supports 300 bits per second.

The DF03 and DF02 allow you to make or receive calls. They offer automatic answer and/or automatic dial, and they plug into a standard telephone wall outlet. The DF01 allows you to make calls and transmit or receive data. It does not allow you to receive calls. Therefore, the other end of the link must be connected to a modem with a receive option or a connection cannot be made.

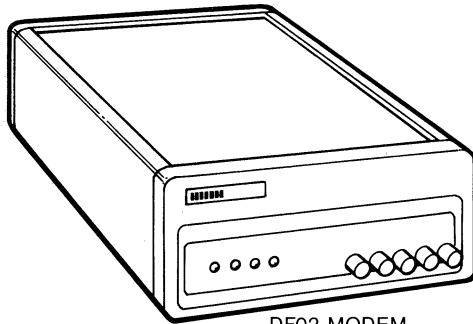

DF02 MODEM

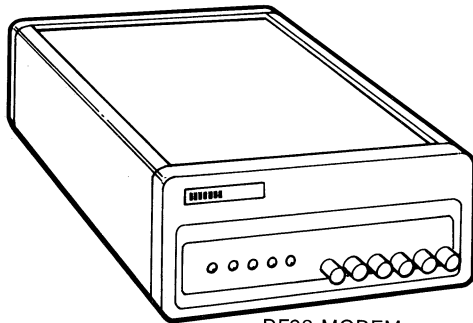

DF03 MODEM

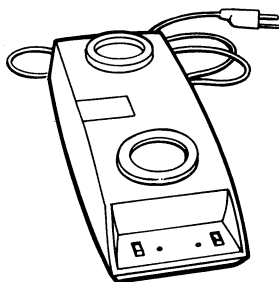

DF01 MODEM

MA-10,318

Figure 3-5 DIGITAL Modems

Other modems that can be used on DIGITAL's systems are made by Vadic, Anderson Jacobson, the Bell System, and manufacturers of modems compatible with Bell System products.

NOTE: DECmate II can be used with Bell System modems of the following types:

- | | |
|-----------------|------------------|
| <i>Bell 103</i> | <i>Bell 208</i> |
| <i>Bell 113</i> | <i>Bell 209</i> |
| <i>Bell 202</i> | <i>Bell 212A</i> |
| <i>Bell 203</i> | |

Installing Modems. Use the manuals shipped with the modems for installation and operation procedures. To connect modems to your DECmate II, note the requirements in the following paragraphs.

Cables. The DF02 and DF03 modems require a BCC04 modem cable. For the DF01 modem, use the cable shipped with it.

Figure 3-6 shows the cabling arrangement for connecting a DF01 modem to your DECmate II.

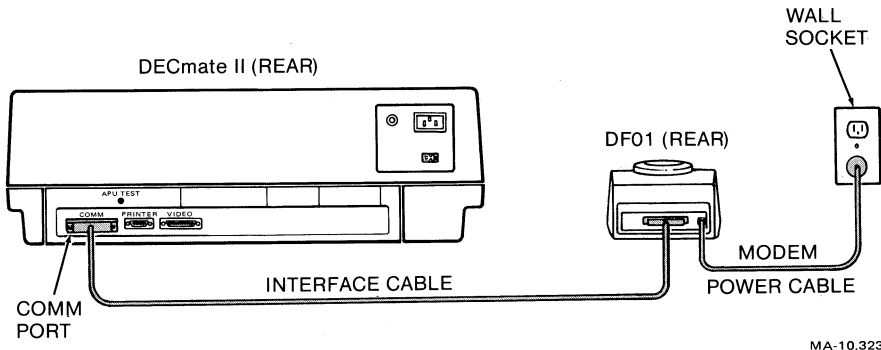

MA-10,323

Figure 3-6 DF01 Modem Cabling

Figure 3-7 shows the cabling arrangement for connecting a DF02 modem to your DECmate II.

Figure 3-8 shows the cabling arrangement for connecting a DF03 modem to your DECmate II.

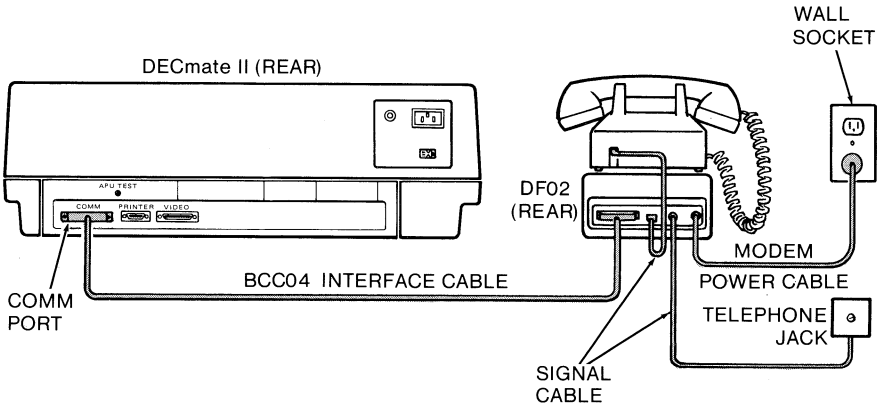

MA-10,324

Figure 3-7 DF02 Modem Cabling

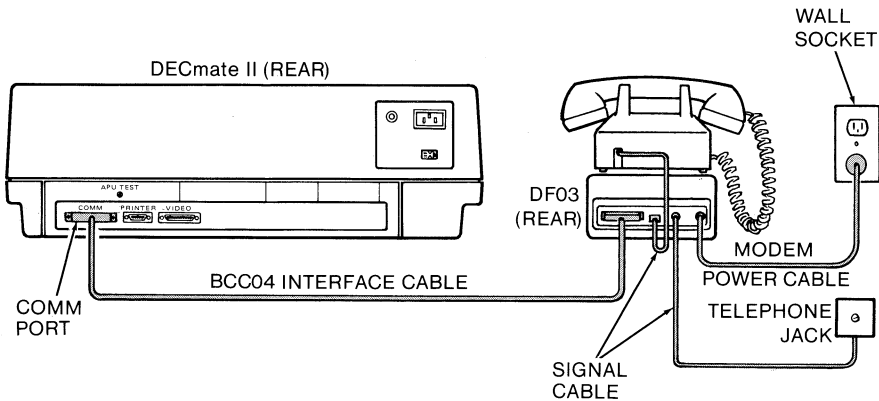

MA-10,321

Figure 3-8 DF03 Modem Cabling

Baud Rate. The DECmate II communications port has been factory set at 1200 baud. To adjust the baud rate, consult your application software manual.

Data Format. The DECmate II has been factory set with a data format of eight data elements, one stop bit, and no parity. To adjust data format, consult your application software manual.

Hardwiring Your System

When you hardwire your DECmate II, you make a direct cable connection between it and another system. Hardwiring can be done in two ways. One way is with a null modem cable; the other is with short-haul modems.

Null Modem Cable. Two DECmate II systems or a DECmate II and a host computer can be connected via a direct cable connection. Transmission speeds from 300 baud to 9600 baud are possible, depending on the distance. For distances up to 152 meters (500 feet), 9600 baud is feasible; from 152 meters (500 feet) to 303 meters (1000 feet), 2400 baud is more appropriate.

The cable that connects the two systems is called a null modem cable. Order numbers are as follows:

- BC03M-25, 8 meters (25 feet)
- BC03M-AO, 30 meters (100 feet)
- BC03M-B5, 76 meters (250 feet)
- BC03M-EO, 152 meters (500 feet)
- BC03M-LO, 303 meters (1000 feet)

NOTE: *If a DIGITAL computer is on the other end of the communications link, the cable attaches to any EIA communications port on the multiplexer (DZ11 or DH11).*

Short-Haul Modems. If your application requires high-speed, 9600-baud transmission over distances greater than 152 meters (500 feet) but less than 6.08 kilometers (3.8 miles), use the following equipment:

- A pair of short-haul modems (available through Gandalf Corporation).
- A 4-conductor, twisted pair cable of 26 gauge or larger (Belden 8444) to connect the pair of modems. The cable should be supplied by a local electronics distributor and installed by a local contractor.
- A pair of modem cables to connect each modem to its respective terminal or host.

Figure 3-9 shows a communications connection using short-haul modems.

Using Leased or Private Lines

If you require good-quality, high-speed transmission over considerable distances, you can use leased or private lines. These lines are permanently in place between two end points. Modems like the Bell 103F are available for private line use. The physical connections of cables to systems and modems are the same as described for dial-up links.

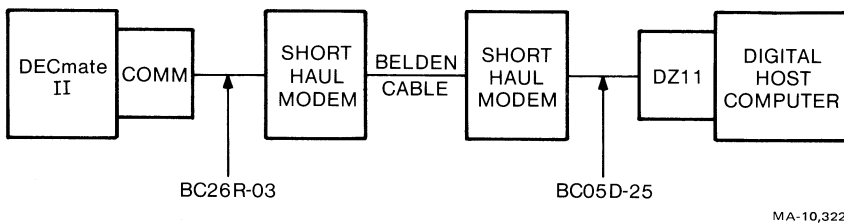

Figure 3-9 Communications Connection Using Short-Haul Modems

4

Keyboard

General

The keyboard is your direct link to the computer system. It transfers your information to the system to be processed or stored, and it transfers messages from the computer to the keyboard indicators.

This chapter provides a general description of the keys and the audio and visual indicators on the keyboard. Use your software manuals for specific information on how to use the keys in a given application.

Connecting the Keyboard

The keyboard cable is a coiled cable with two straight extensions of uneven length at each end. You can route the cable to extend from the left or right side of your keyboard (as the keyboard faces you).

To route the cable out the left side, connect the shorter end to the connector on the underside of the keyboard. Press the uncoiled cable length through the shorter groove in the keyboard.

To route the cable out the right side, connect the longer end to the connector on the underside of the keyboard. Press the uncoiled cable length through the longer groove in the keyboard.

How the Keys Work

The keys actually work in three ways. They (1) transfer information, (2) issue commands, or (3) control the way keyboard information is handled. The way the keys work depends on the context and combinations in which you use them.

Data Function

When a key acts as a data key, the system records and displays on the video monitor screen the symbol on the top of the keycap. For example, if you press **P**, the system interprets it as P (or p). If you press **2**, it is interpreted as 2.

Command Function

When a key acts as a command key, it causes the computer system to perform an operation. Commands are defined by your application software and may or may not be displayed on the video monitor screen. One example of a command key is **Do**.

Some commands are incorporated into data keys. For users of WPS application software, the keys with words or abbreviations on their front edges work as either data or command keys. The **P** key used alone is P; the **P** key used with the **Gold** key becomes **Page Marker**, a command you send to the system to mark your text by pages.

Control Function

When a key acts as a control key, it sends a signal that affects the recording, processing, transmission, or interpretation of what is sent. The **Shift** key is an example of a control key. Holding down **Shift** and then pressing an alphabetic key causes the system to interpret that alphabetic key in its uppercase form. Control functions can be generated by single keys, combinations of keys, or by keys in a particular context. Like the data and command functions, control functions are defined by your application software.

The Four Key Groups

There are four main groups of keys on the keyboard as shown in Figure 4-1:

- Main keyboard
- Arrow keypad
- Numeric/editing keypad
- Special function keys

NOTE: Many of the following descriptions refer to a cursor. A cursor (Figure 4-2) is a block or underline on the video monitor screen that marks the current position in the text. It can be blinking or stable. You can insert or delete text at the cursor position.

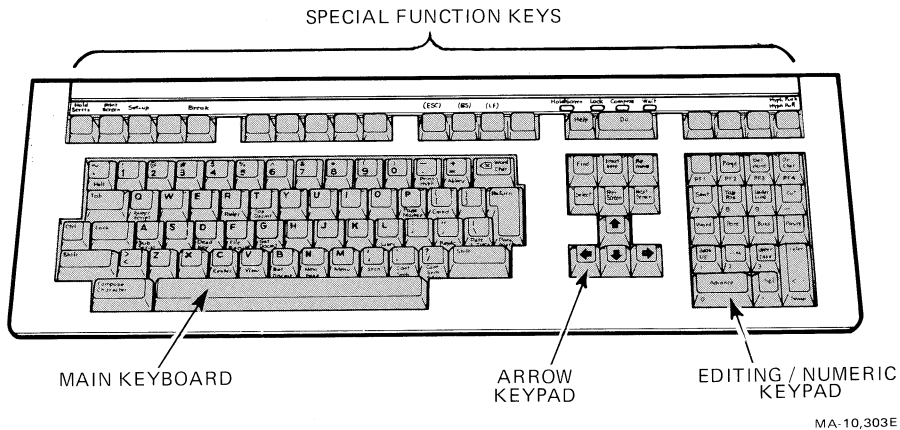

MA-10,303E

Figure 4-1 Keyboard

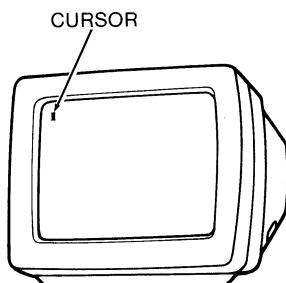

MA-10,325

Figure 4-2 Cursor on Video Monitor Screen

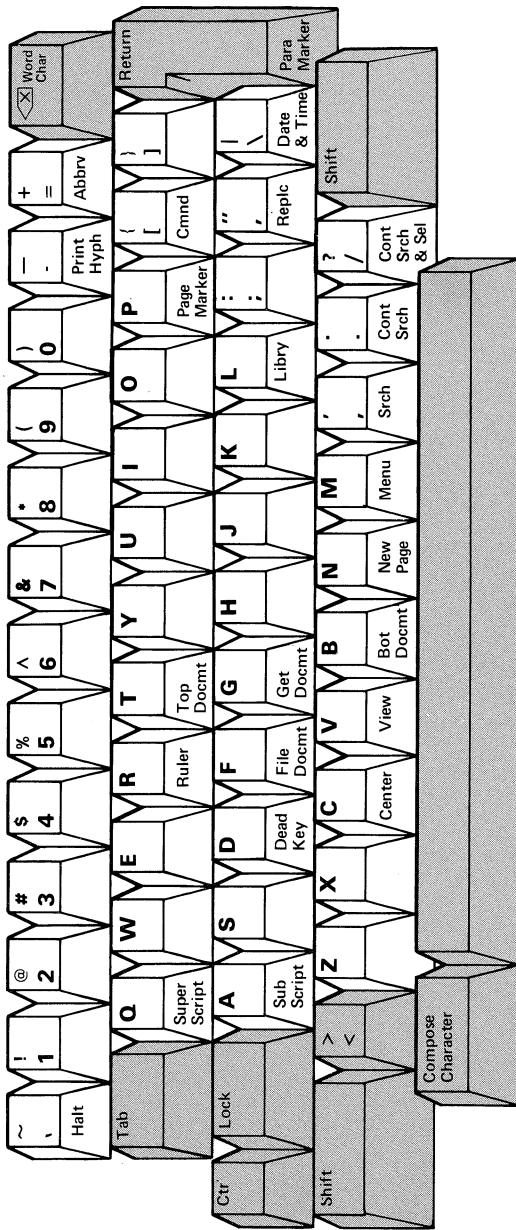

MA-10.326

Figure 4-3 Main Keyboard

Main Keyboard

The main keyboard (Figure 4-3) looks and operates like a standard typewriter. Pressing a letter, numeral, or symbol key enters that character in the system's memory and usually displays it on the video monitor screen.

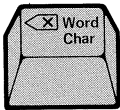

Word/Character

Pressing **Word/Char** (rubout) erases one character to the left of the cursor. In some cases, using this key with other keys (**Ctrl**, **Gold**) deletes more than one character.

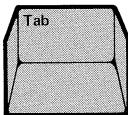

Tab

This key works in almost the same way as it does on a typewriter. In some cases, pressing **Tab** moves the cursor and the text following it to the next tab stop setting.

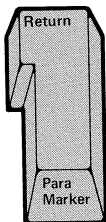

Return

Pressing **Return** generates either a carriage return or carriage return and linefeed. Linefeed is an action in which the last text line entered moves up one whole line. In some cases, **Return** moves the cursor to the next line when you are editing text. In others, **Return** is a signal to the system that a certain operation is finished.

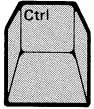

Control

This key works with another key. Holding down **Ctrl** and pressing another key transmits a control code to your system. A control code tells the system to perform a predefined operation. Some codes affect communications, while others affect the printer or the video monitor display. An example of a control code entered at the keyboard is **Ctrl Z**, recognized by some software as a signal to terminate an editing session.

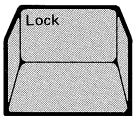

Lock

When pressed, **Lock** makes the 26 alphabetic keys generate uppercase characters. When pressed again, the alphabetic keys generate lowercase characters. When **Lock** is engaged, the Lock LED glows until the key is disengaged. **Lock** affects only the 26 alphabetic keys.

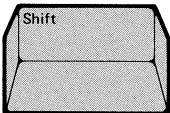

Shift

When you hold down **Shift**, the keys on the main keyboard generate uppercase characters or symbols.

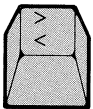

Greater Than/Less Than

This key generates the symbols that mean *is greater than* and *is less than*.

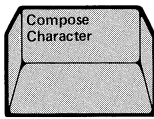

Compose Character

This key is not functional at the time of this printing.

Space Bar

Pressing the space bar moves the cursor to the next character space. It operates by inserting an invisible character at the current position.

Editing Keypad

This group of keys (Figure 4-4) contains only command keys. In WPS the numbers are not functional. Most of the keys are commands used for editing text. **Advance** and **Back Up** have additional functions. The **Gold** key is used with the keys that have gold lettering.

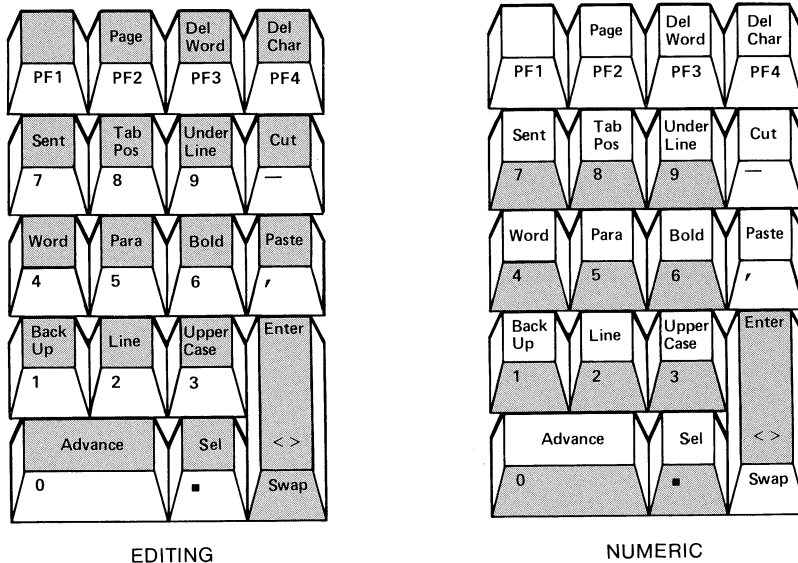

MA-10,327

Figure 4-4 Editing/Numeric Keypad

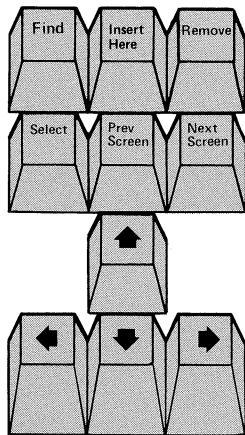

MA-10,328

Figure 4-5 Arrow Keypad

Numeric Keypad

The numeric keypad (Figure 4-4) is for rapid entry of numbers. In this application the words on these keys have no meaning. **Enter** <> terminates the entry.

Arrow Keypad

This group is pictured in Figure 4-5. In some applications, the arrow keys move the cursor in the direction indicated by the arrow. **Remove** and **Select** are used during SET-UP. (See Chapter 6.) The other keys are defined by your application software or not used.

Special Function Keys

The special function keys are shown in Figure 4-6. If a keyboard legend strip is shipped with your application software, then place it in the legend strip storage area on your keyboard to identify these keys. Your application software manuals describe the function of these keys. The following paragraphs describe their functions in some applications.

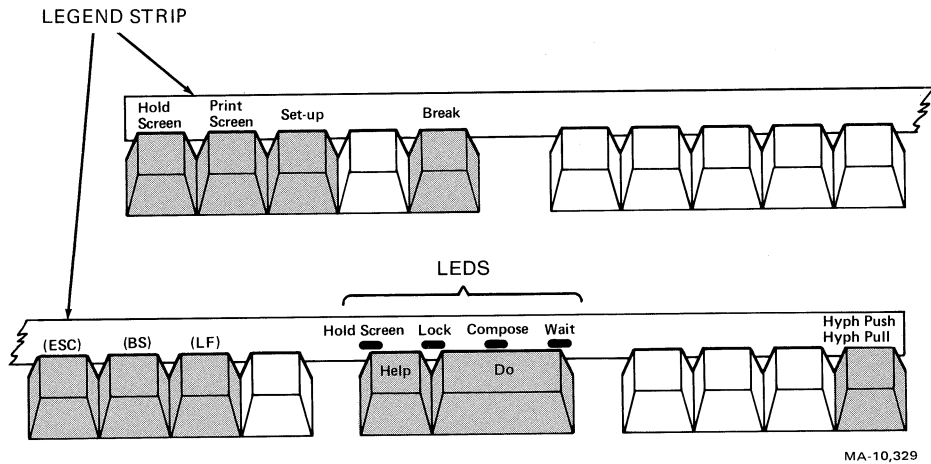

MA-10,329

Figure 4-6 Special Function Keys



Pressing this key freezes the screen display and stops any characters from being transmitted to the video monitor screen. When this key is activated, the **Hold Screen** LED glows. Pressing this key again returns the system to normal operation.



This key causes the system to stop all screen activity and then transfer the contents of the video monitor screen to the printer.

Break

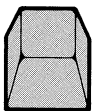

Break

This key is used with other keys to start or stop communications with a modem.

Set-up

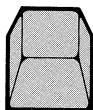

Set-up

This key displays a special screen that allows you to determine certain operating characteristics of the DECmate II, such as character size. See Chapter 6 for information.

(ESC)

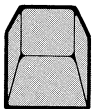

Escape

This key is used with other keys to control features of the keyboard and screen. The escape sequences for controlling these features are usually programmed codes, but they can be entered via this key in some application software.

(BS)

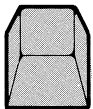

Backspace

This key sends a backspace control signal to the CPU in certain cases. Do not confuse this key with the **Word/Char** (rubout) key on the main keyboard.

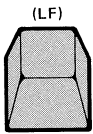
**Linefeed**

This key sends a linefeed control signal to the CPU in certain cases. Do not confuse this key with the **Line** key on the numeric/editing keypad.

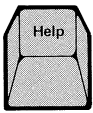
**Help**

This key provides the user with a help menu, a selection of topics that help to clarify a feature of the system (provided that your system software has a help feature).

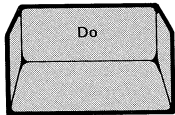
**Do**

This key issues a command to begin executing selected operations.

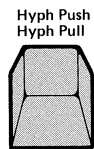
**Hyphen Push/Hyphen Pull**

This key is used only with WPS application software. It is for moving characters by the syllable to hyphenate words correctly during pagination.

Keyboard Indicators

The system uses lights (LEDs) and sounds in the keyboard to send information to you.

The LEDs shown in Figure 4-7 have the following meaning.

Hold Screen

This LED glows when the **Hold Screen** key has been pressed and screen output is inhibited. This LED goes off when the **Hold Screen** key is pressed a second time.

Lock

This LED glows to show that the **Lock** key has been pressed. When this LED is on, the system prints in capital letters only. When the **Lock** LED is off, the system prints in uppercase and lowercase letters. The **Lock** LED goes off when the **Lock** key is pressed a second time.

Compose

This LED glows when the power-up self-test indicates there is a nonfatal error in the system.

Wait

This LED glows to show that the keyboard is prevented from transmitting information. This rare condition is initiated by the CPU and can be cleared by rebooting the system.

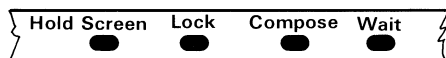

MA-10,330

Figure 4-7 Keyboard LEDs

Keyclick

A keyclick sounds when you press a key. The following situations are exceptions to the rule:

- You press **Shift** or **Ctrl** only.
- The **Wait** LED is on; characters from the keyboard are lost.
- The keyclick SET-UP feature is off.

Bell Tone

A bell tone sounds at power-up and in selected cases. If the keyboard has a problem, it automatically uses the SET-UP features to which it was set when shipped. See Chapter 6 for information.

5

Diskettes

General

A computer system cannot work for you without diskettes. They store not only your own information, but also the programs that must be read into the system before your DECmate II can run.

This chapter describes diskettes and tells you how to handle, store, and insert diskettes in your DECmate II.

What Is a Diskette?

A diskette is a thin, flat, round plate coated with a magnetic surface. It is permanently enclosed in a square protective cover. The RX50 diskette drive reads programs and writes your information on a diskette through the openings in its protective cover.

There are three kinds of diskettes: system diskettes, document or application diskettes, and test or diagnostic diskettes. They must be placed in the correct drive door for the system to be able to use them.

Figure 5-1 shows a system unit with an optional second RX50 diskette drive installed in it. It shows four drive doors. The doors are labelled 0, 1 (basic system), 2, and 3 (extra RX50 drive or hard disk drive), designations used by WPS application software. The letters in parentheses, (A), (B) (basic system), (C), (D) (extra RX50 drive), and (E) (hard disk drive) are designations used by CP/M application software.

A system diskette contains the program that controls how DECmate II operates. Always load it into your system first. You place it in drive 0 (A).

A document or application diskette contains your own work. You place it in drive 1 (B), 2 (C), or 3 (D).

A system test diskette checks out your system and displays the results on the video monitor screen. Place it in drive 0 (A).

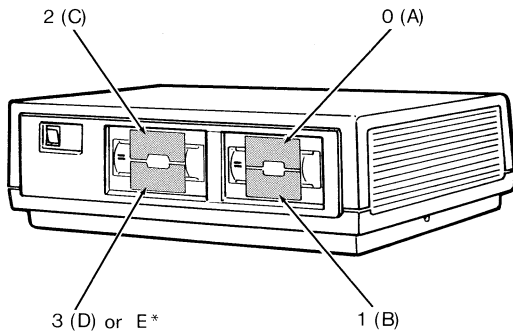

*NOTE
IF THE HARD DISK DRIVE OPTION
IS INSTALLED, ITS DESIGNATION IS E

MA-1105-83

Figure 5-1 RX50 Drive Door Designations

What a Diskette Looks Like

The DECmate II diskette is 5-1/4 inches in diameter and stores about 400,000 bytes of data. One data diskette provides about 200 pages of text. Since diskettes are flexible in their unprotected state, they are often called *floppy* diskettes, or just *floppies*.

If you already have RX01 or RX02 diskettes, you can install an optional RX01/RX02 board in your system unit. It allows you to transfer data to and from the 8-inch diskettes and onto your DECmate II diskettes.

Figure 5-2 shows the top of a diskette. The blank label is for identifying the diskette's contents. The red arrow points to the edge that you insert into the diskette drive. For drives 0 (A) and 2 (C), the arrow and label should be visible. For drives 1 (B) and 3 (D), the blank side of the cover should be visible.

The protective cover in the diskette has four openings. The large center hole in the diskette shows where the diskette rests on a spindle inside the diskette drive. Once you close the door, the spindle spins the diskette inside its cover.

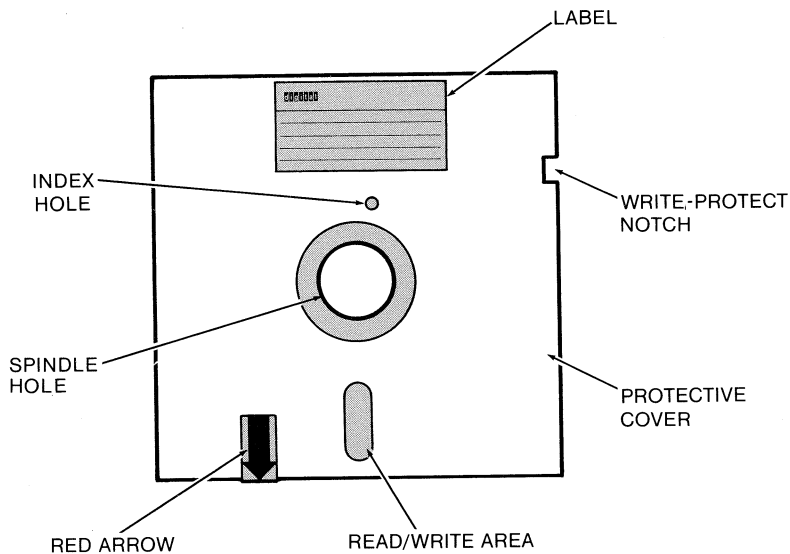

MA-10,229

Figure 5-2 RX50 5-1/4 Inch Diskette

The index hole is used by the system to synchronize operations. Whenever the diskette is used, a small light shines through the index hole seeking a smaller hole in the diskette.

The large oval opening in the protective cover shows the area to which the system reads or writes. You should never touch this part because you can damage the magnetic patterns that form information.

The write-protect notch prevents overwriting on material you want to save. When the notch is open, the system can read and write information on the diskette. When the notch is covered, the system can only read information on the diskette, not change it.

NOTE: Check your *applications manuals* for any variations in the use of the write-protect feature.

How to Handle Diskettes

Diskettes must be handled carefully. The fingers should touch only the cover, never the surface of the diskette inside. Use the following precautions when you handle diskettes:

- Write on the label before you place the label on the diskette.
- Use only the labels provided with the diskette.
- Use only a felt-tip marker to write on a label (Figure 5-3).
- Handle the diskette only by its edges. Never touch the exposed part of the inner disk.

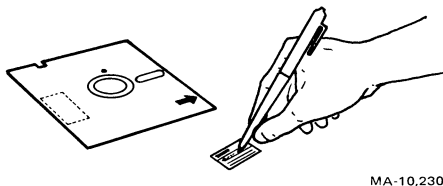

MA-10,230

Figure 5-3 Labelling a Diskette

- Keep the diskette flat.
- Do not clean the diskette.
- Keep the diskette away from direct sunlight, heat, water, dust, and extreme cold. If a diskette is exposed to cold, allow 15 minutes to bring it to room temperature before you use it.
- Do not use paper clips on a diskette.
- Keep the diskette away from the video monitor, magnets, tools, phones, or large electric motors. Do not put it on top of the system unit.
- Do not place heavy items on a diskette.
- Store diskettes in their envelopes horizontally in stacks of ten or less.

How to Insert a Diskette In a Drive

Use the following steps to insert a diskette in a drive.

1. Remove the diskette from its envelope.
2. Select the diskette drive you will use.
3. Gently push on the outer edge of the door as shown in Figure 5-4.

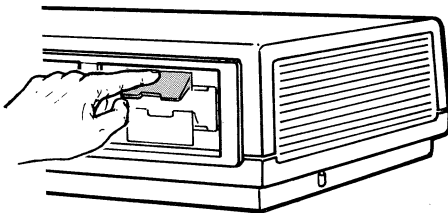

MA-10,226

Figure 5-4 Opening a Diskette Drive Door

4. Orient the diskette. Figure 5-5 shows the system unit in a horizontal position. If you are using the upper drive, make sure the diskette's label is facing up and the arrow is pointing toward the drive. If you are using the lower drive, make sure the diskette's label is facing down and the arrow is pointing toward the drive.
5. Slide the diskette all the way into the drive.

CAUTION: *Do not force a diskette into a diskette drive. If you have trouble, remove it and try again.*

6. Close the diskette drive door by gently pushing on the inner edge of the door.

CAUTION: *Do not force the door if it does not close easily. Instead, remove the diskette and put it back into the drive.*

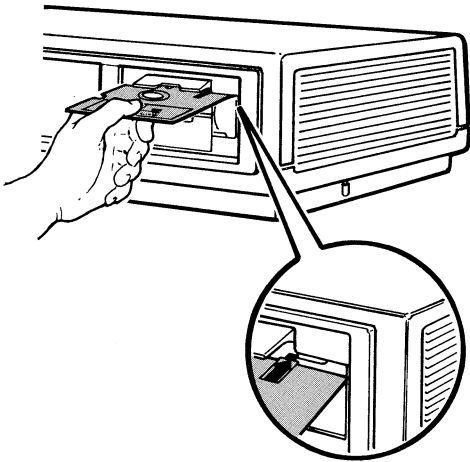

MA-10,227

Figure 5-5 Orienting and Inserting a Diskette

Preventing Problems

- Before you turn off DECmate II, first open the diskette drive doors and take out the diskettes. You can lose text if you switch DECmate II off while you are editing or entering information.
- When running programs that write information to diskettes, never exchange one diskette for another except when the application tells you to do so.
- When you change system diskettes, restart or reboot the DECmate II via SET-UP if the new diskette has a different version of software on it.
- Leave some free space on your document diskettes. Do not allow them to become so full that you risk running out of space while trying to write to them.
- Never open the diskette drive door when the drive LED is on.
- Static electricity can add extra characters or garble the text on your diskette. Help prevent static electricity by increasing the humidity in the room or using antistatic mats around DECmate II.

If You Find Problems

- Make sure the diskette drive door is closed before trying to use your diskette.
- Make sure the diskette drive contains a diskette.
- Make sure the diskette is inserted properly. The label should be up for a diskette going into the upper drive and down for a diskette going into the lower drive.
- Make sure your diskette is not damaged.

6

Turning On Your DECmate II

General

When you turn on your DECmate II, internal programs in the electronic circuitry perform tasks that initialize and test your system. Initializing is a process that electrically prepares the system for operation. Testing is a process that checks whether circuits are working the way they are supposed to work. Every time you turn your DECmate II off and on, the system initializes and tests itself.

An initialized system has certain established operating features. Some of these operating features, known as SET-UP features, are found on the user selections menu and can be adjusted with specific procedures in your application software manuals.

This chapter describes the SET-UP features to which your system was set when it was shipped to you. It also describes the procedures you use to turn on your DECmate II.

How to Turn On Your DECmate II

These steps show you how to turn on your DECmate II and insert a system diskette.

1. Make sure the power switch is off (0).
2. Set the contrast and brightness controls on the video monitor to the midpoint.

3. Open the drive doors and check that all the drives are empty.
4. Turn on your printer if you are using one.
5. Push the power switch on (1).

It takes about 12 seconds for the system to power up.

NOTE: *Systems with the hard disk subsystem option take about 25 seconds to power up.*

During this time the system is initializing and testing itself with a power-up self-test. While this happens, the keyboard beeps once and the keyboard LEDs glow briefly. You may also hear the diskette drive(s) buzzing.

When the system finishes initializing and testing itself, a message appears on the video monitor screen (Figure 6-1). This message indicates that the power-up self-test found no problem.

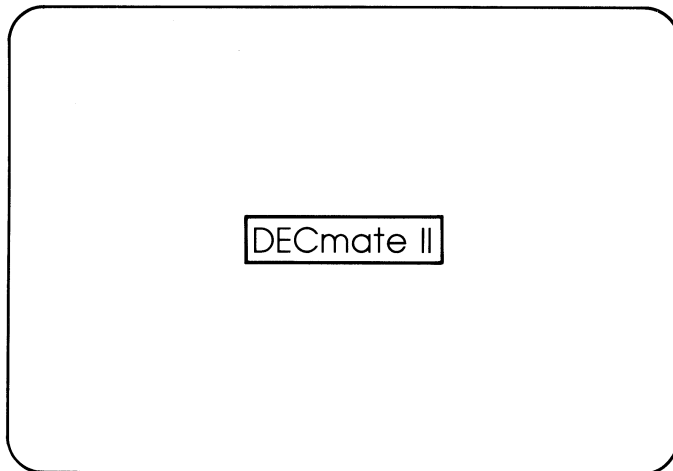

MA-10,333

Figure 6-1 Message for No Problem

6. Insert your system diskette. The label on the system diskette should be facing up if the system unit is horizontal, facing left if the system unit is vertical.
7. Close the drive door. The startup display of your application software will appear on your video monitor screen.

If the screen shows a blinking picture of a diskette (Figure 6-2), one of the following conditions exists:

- No system diskette is in the drive. Put your system diskette in drive 0 (A).
- The wrong diskette is in drive 0 (A). Make sure your system diskette is in drive 0 (A).
- There is an error on the diskette. Use a new diskette.

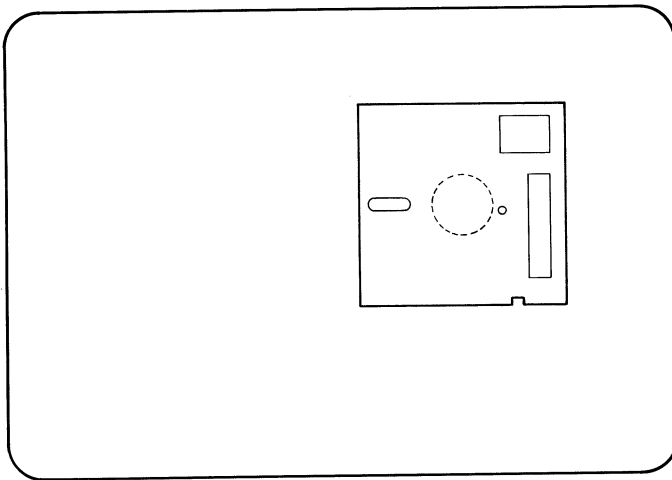

MA-10,334

Figure 6-2 Drive 0 (A) Error Message

If your screen shows a number in the center (Figure 6-3), there is a problem with one of the components. Go to Chapter 7 for instructions on how to correct the problem.

If you are loading the system from a hard disk and the correct screen display fails to appear, one of the following error messages may appear:

```
Winchester Read Error  
Winchester Write Error  
Data Comparison Error  
Winchester Format Error  
Too Many Bad Blocks on the Hard Disk
```

NOTE: *Winchester is another name for the hard disk drive.*

Refer to your application software manuals for an explanation of the error messages.

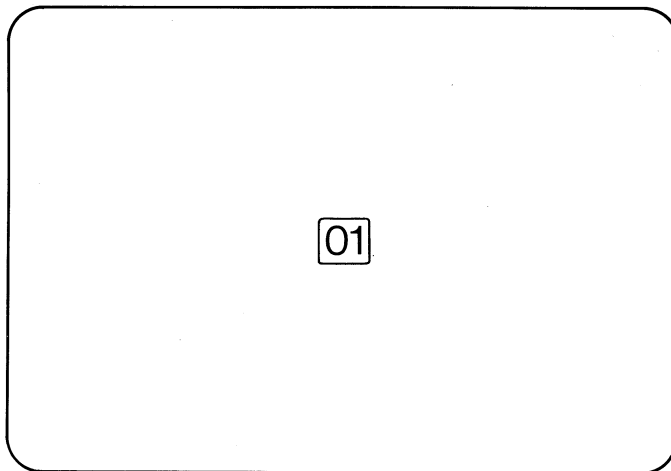

MA-10,332

Figure 6-3 Self-Test Error Message

User Selections

When you turn on your DECmate II, the system automatically sets itself to certain operating features. Generally known as user selections, these features can be selected or enabled by means of a menu.

NOTE: *Your application software manuals contain the specific procedures you need to get this menu.*

The following example shows the user selections menu. The features that are in reverse video are the current features to which the DECmate II is set.

User Selections Menu

Screen Width	80	132
Cursor Style	Block	Underline
Cursor Visibility	Visible	Invisible
Scrolling	Fast	Slow
Screen Mode	Normal	Reverse
Keyboard Keyclick	On	Off
Terminal Mode	VT100	VT52

Baud Rates

Printer 300, 600, 1200, 2400, **4800**, 9600

Communications 300, 600, **1200**, 2400, 4800, 9600

Press:

'->' to Advance '<-' to Backup 'Select' to fix new selection
 'Do' to fix new selections and leave Selections Menu
 'Return' to use new selections and leave Selections Menu
 'Remove' to load new System Disk

The following paragraphs explain the instructions at the bottom of the menu.

Press '->' to Advance '<-' to Backup 'Select' to fix new selection

This instruction tells you to move the cursor to the feature you wish to select. Press either the ← (left arrow) or → (right arrow) on the arrow keypad. The → (right arrow) key moves the cursor across and down. The ← (left arrow) key moves it back and up. Once you have moved the cursor to your selection, press the **Select** key on the arrow keypad. The feature now appears in reverse video. You may move the cursor into position and press the **Select** key repeatedly until you select all the features you wish to select.

Press 'Do' to fix new selections and leave Selections Menu

Once you have made all your selections, press the **Do** key. Pressing **Do** causes the bottom line of the display to be written with the following message:

Are you sure? Press 'Do' to confirm

Pressing **Do** again sets the new features and saves them when the DECmate II is next initialized. It causes the system to consider the selections as final. The user selection features you have selected will be implemented until you change them again.

Press 'Return' to use new selections and leave Selections Menu

Use this instruction to make temporary selections. Once your selections are made, press the **Return** key. Pressing **Return** causes the system to consider your selections on the screen as final only until the DECmate II is initialized again. The selections menu disappears.

Press 'Remove' to load new System Disk

You use the selections menu to change the system diskettes. Pressing the **Remove** key allows you to remove the current system diskette and replace it with another. It clears the screen and displays the following message:

Insert new System Disk and Press 'Do'
Any other key will return to User Selections Menu.

NOTE: *Check your application software manuals for variations in this procedure.*

Pressing **Do** transfers the new system program from the new diskette in drive 0 (A), bringing with it its own set of screen and system operation defaults. Pressing any other key returns you to the beginning of the user selection program.

Part 3

Solving
Problems

7

What to Do If Your DECmate II Doesn't Work

General

DECmate II capabilities are controlled by hardware and software. Sometimes it is difficult to find the source of a failure. The process of searching for the source is known as troubleshooting, a deductive process that starts with discovering whether the problem is with the software or hardware. Troubleshooting involves checking your power source and working through the components of the basic system, the options, and even your diskettes.

DECmate II has been designed to help you troubleshoot. It runs a power-up self-test of its system board every time you turn it on. It is shipped with a system test diskette that you can run when you need additional automatic troubleshooting.

DIGITAL makes available a telephone HELP LINE when you need to talk to qualified representatives, and DIGITAL offers a wide range of maintenance and support services.

If you want to service your DECmate II yourself, an optional *DECmate II Repair Guide* provides detailed troubleshooting and module replacement procedures.

This chapter describes the actions to take and the resources available to you if your DECmate II doesn't work.

When to Call the HELP LINE at Once

Under certain circumstances, you should immediately unplug your system and call the DIGITAL HELP LINE. Do not try to fix the DECmate II yourself if you notice any of the following symptoms:

- Burning odor
- Smoke
- No sound of fan or diskette drive running
- Screeching noise
- Liquid spilled through air vents

Call DIGITAL at one of the following HELP LINE numbers.

USA

Mainland (800) DEC-8000
Alaska, Hawaii (404) 953-0552

Austria (222) 67 76 41, extension 444
Belgium (02) 24 26 790
Canada (800) 267-5251
Denmark (04) 30 10 05
Finland (90) 42 33 32

France (1) 687 31 52
Holland (1820)-31 100
Italy (02) 617 53 81 or 82
Japan (0424) 64-3302
Norway (02) 25 64 22

South Pacific Region

Sidney (02) 412-5555
Other (008) 226377

Spain (1) 73 34 307
Sweden (08) 98 88 35
Switzerland (01) 810 51 21
United Kingdom (0256) 59 200
West Germany (089) 95 91 66 44

Power-Up Self-Test

Every time you turn on your DECmate II, an internal self-test checks the system board and keyboard. The test is automatic and does not require that you type anything to activate it. The test takes about 4 seconds (or 25 seconds if your system has a hard disk drive). At the end of the test, watch the keyboard LEDs and the video monitor screen for the results. The screen displays one of three messages. The meanings of the LED indications and the messages on the screen are explained in the following paragraphs.

No Problems

At the end of a successful self-test, all the keyboard LEDs flash twice and the keyboard beeps once. Figure 7-1 shows the message that appears on your video monitor screen. All of these indicators, together, mean that the test has found no problems. The message remains on your screen until you insert a diskette in your system.

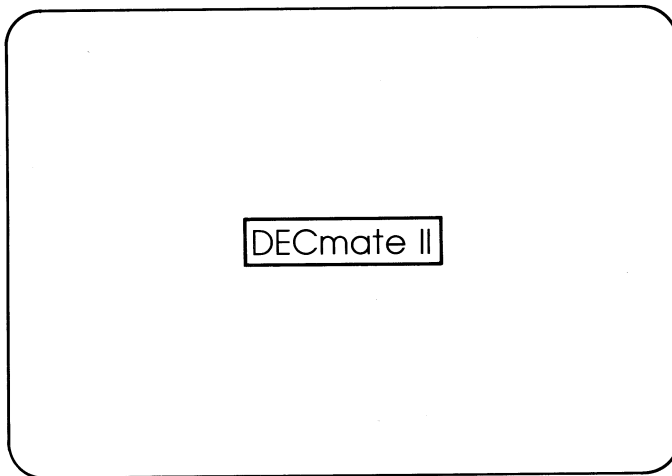

MA-10,333

Figure 7-1 Self-Test Message for No Problems

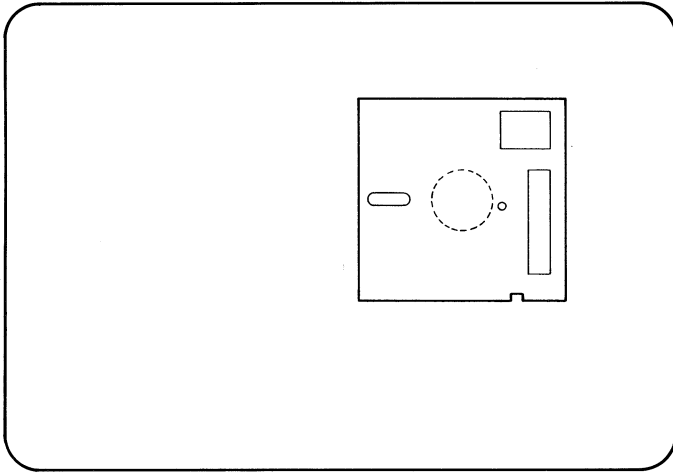

MA-10,334

Figure 7-2 Self-Test Message for Wrong Diskette

Wrong Diskette

Figure 7-2 shows the message that blinks on the screen to indicate that you have the wrong diskette in drive 0 (A). It remains on your screen until you insert a valid system diskette in drive 0 (A).

Problems

Figure 7-3 shows a sample of a message that appears when the power-up self-test has detected a problem. This message consists of a number, or error code. The sample message shows a 01, the error code that indicates something is wrong with the printer port circuitry.

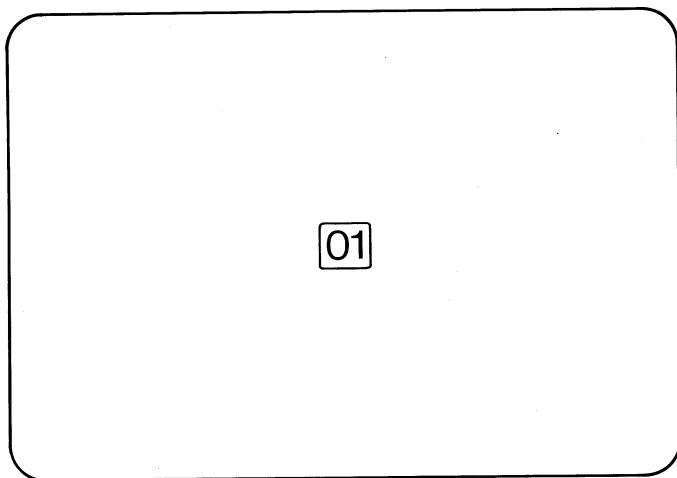

MA-10,332

Figure 7-3 Self-Test Message for Error (1)

If your screen shows a number, use the following procedure.

1. Turn off (0) the power switch. Wait 4 seconds and turn it on (1) again. If there is still a problem, continue with this procedure.
2. Record the number.
3. Turn off (0) the power switch.
4. Turn to Table 7-1 for an explanation of the error message and what you should do to correct the problem.
5. Use your optional *DECmate II Repair Guide* or
6. Call the DIGITAL HELP LINE.

This message remains on the screen until you press any key.

The power-up self-test checks six items on your system board. Each item is assigned one of the following numbers: 01, 02, 04, 08, 16, 32. The number can appear alone or added to another number. If you see a 12, for example, it means that the test found errors 04 and 08.

Table 7-1 Power-Up Self-Test Error Codes

Error Code	Probable Cause	What To Do
01*	System board – printer port.	You can operate the DECmate II, but it will not print anything. To reestablish printer operations, replace system board.
02*	System board – real time clock.	You can operate the DECmate II, but you will not be able to log in time. For full capability, replace system board.
04*	System board – control interrupt.	Replace system board.
08	System board – keyboard interface.	Replace system board.
16	Keyboard cable disconnected at one or both ends.	Check to see if keyboard cable is plugged in all the way at both ends.
	Keyboard – all LEDs on keyboard glow steadily.	Replace keyboard.
	Keyboard – one or more keys are pressed.	Reboot.
32	System board – diskette drive interface.	Check to see that the internal drive power and signal cables are connected properly.
		Replace system board.

* These error codes (01, 02, 04) may appear when booting if the interval between turning off and turning on the system is less than 4 seconds. First, try rebooting to see if there really is a problem with the system board.

Table 7-1 lists the numbers and the problems detected on the system board. Some errors are nonfatal, that is, there is the possibility that you can still use the system. An example of a fatal error is error code 32, diskette drive interface failure. Table 7-2 tells you what to do in the case of various combinations of error codes.

NOTE: To tell if an error is fatal, press any key after the error code appears on the screen. If nothing happens, the error is fatal.

Error Code	Replace System Board	Replace Keyboard
03	X	
05	X	
06	X	
07	X	
09	X	
10	X	
11	X	
12	X	
13	X	
14	X	
15	X	
17	X	X
18	X*	X
19	X	X
20	X	X
21	X	X
22	X	X
23	X	X
24	X	X
25	X	X
26	X	X
27	X	X
28	X	X
29	X	X
30	X	X

* The real time clock has failed. You can operate the system, but will not be able to log in the time. For full capability, replace the system board.

Table 7-2 Combined Power-Up Self-Test Error Codes (Cont)

Error Code	Replace System Board	Replace Keyboard
31	X	X
33	X	
34	X	
35	X	
36	X	
37	X	
38	X	
39	X	
40	X	
41	X	
42	X	
43	X	
44	X	
45	X	
46	X	
47	X	
48	X	X
49	X	X
50	X	X
51	X	X
52	X	X
53	X	X
54	X	X
55	X	X
56	X	X
57	X	X
58	X	X
59	X	X
60	X	X
61	X	X
62	X	X
63	X	X

Table 7-3 shows self-test problems that are not indicated by error codes. Use this table if the keyboard LEDs indicate a problem or the blinking diskette appears on the screen.

Table 7-3 Power-Up Self-Test Problem Indicators		
Symptom	Probable Cause	What To Do
Blinking diskette on screen.	Wrong diskette in drive 0(A).	Change diskette.
Compose LED on keyboard is on.	Problem with one of the replaceable parts.	Press any key to unlock keyboard and check video monitor screen. If error code appears on screen, refer to Table 7-1 or 7-2 for explanation.
All keyboard LEDs are on. Screen may or may not show two-digit number.	An object was lying on the keyboard at power-up, causing an error reading by power-up self-test.	Remove object from keyboard, turn off (0) power switch, wait 4 seconds, then turn on (1) system.
	Keyboard failure.	Replace keyboard.
Error code (01 through 63) appears on screen.	See Tables 7-1 and 7-2.	See Tables 7-1 and 7-2.

Routine Measures to Take First

If there is a problem not reflected by the power-up self-test, try the following procedures before you turn to the HELP LINE, system test diskette, DIGITAL service, or your *DECmate II Repair Guide*.

- Make sure that electricity comes from the outlet you are using. Test the outlet with a lamp that you know works. If there is no power, check the circuit breaker, then call an electrician.
- Turn off (0) the power switch on the system unit. Leave it off for about 4 seconds and then turn it on (1). This procedure is known as rebooting the system and it runs the power-up self-test again. Reboot a couple of times.
- Check all the connections. The cables and the power cord should be tightly plugged in at both ends. Internal connections should be tight.
- Check the system circuit breaker on the rear of the system unit. If it has tripped, push it in. Reboot the system by setting the power switch first to 0 then 1. If the circuit breaker blows again, unplug the power cord from the wall outlet. First check to see that the voltage switch setting is correct, then consult your optional *DECmate II Repair Guide* or call the HELP LINE.
- Use your system test diskette.

System Test Diskette

Your system was shipped with a system test diskette. You should use it when there is a problem that has not been noted by the power-up self-test.

The system test diskette shows you screen displays that (1) allow you to run the test or update the test itself, (2) provide instructions, and (3) display result messages as the test runs. It also provides functions that allow you to format an optional hard disk drive and to update firmware on the hard disk drive and the system diskette.

The system test checks the system board, the 5-1/4 inch diskette system (RX50 drive and related hardware), the printer, and the printer interface. It also checks the following options: CP/M board, 8-inch diskette system (RX01/RX02 drive and related hardware), extra RX50 diskette drive and related hardware, and hard disk drive and related hardware.

Your system test diskette provides updated diagnostic ability. In the future, if you add an option other than those mentioned above, the option will be sent with a diskette containing a diagnostic test. You will receive instructions to transfer that material onto your system test diskette.

How to Use Your System Test Diskette

Turn on (1) the power switch. Insert the system test diskette into drive door 0 (A). After a brief period, the menu (Figure 7-4) appears. Use the arrow keys to move the cursor to your choice, then press the **Do** key. An explanation of the menu options follows.

```
Run system test
```

This selection allows you to run the system test. When you choose this selection, the display shown in Figure 7-5 appears. When you are ready to run the test, press the **Do** key. The display is then replaced by one similar to Figure 7-6.

When this display appears, the system is testing itself. As each item is tested, its name appears on the screen. Results appear as they are determined. See Figure 7-7 for an example of the display at the end of a test.

NOTE: *The system test causes the printer to print a test page. Look at the printer to verify the printer pattern.*

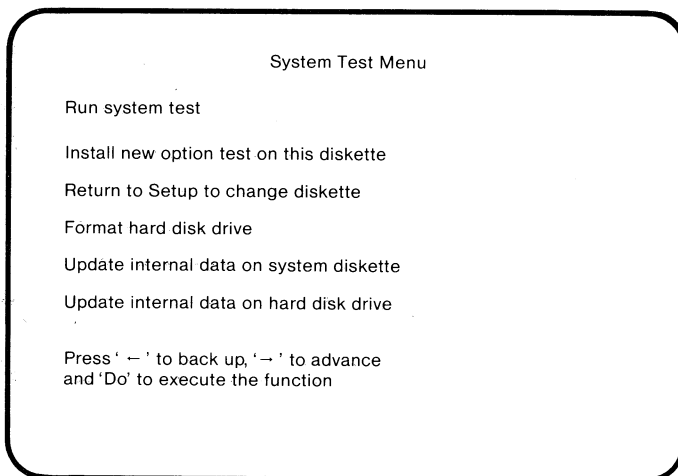

MA-0932A-83

Figure 7-4 Main Menu on System Test Diskette

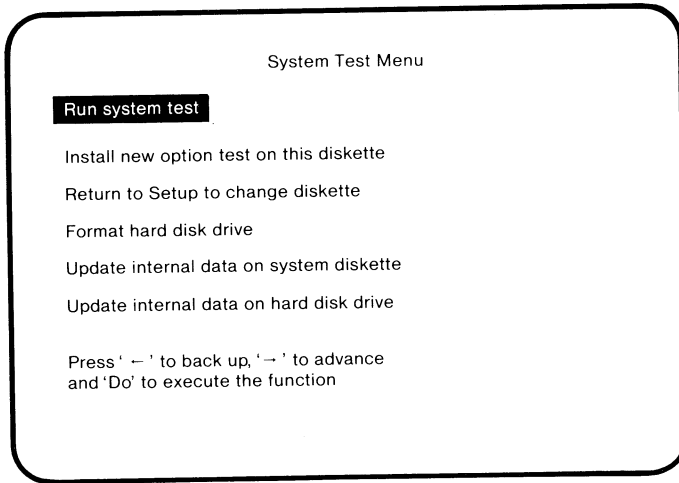

MA-0932B-83

Figure 7-5 System Test Selected

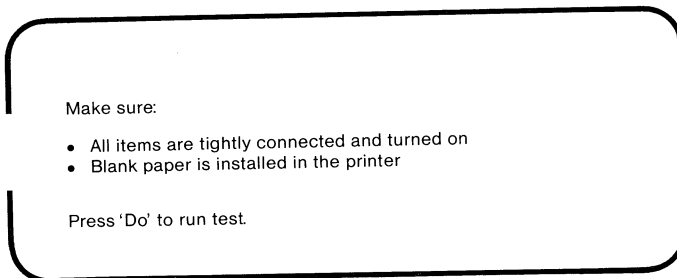

MA-0933-83

Figure 7-6 System Test Ready to Run

DECmate II System Test	
Item being tested	Results
SYSTEM BOARD 1.	OK
PRINTER INTERFACE 1.	OK
PRINTER 2.	This item not found in the system
CP/M BOARD 1.	OK
5.25 INCH DISKETTE INTERFACE 1.	OK
DRIVE 0 (A) 1.	OK
DRIVE 1 (B) 1, 3.	This item not found in the system
DRIVE 2 (C) 4.	This item not found in the system
DRIVE 3 (D) 4.	This item not found in the system
HARD DISK BOARD SET	Problem here
HARD DISK DRIVE 1, 5.	Problem here

Syserr - The required file was not found on the system device
PRESS 'DO' TO CONTINUE

MA-0934-83

1. Reverse video means the system found it.
2. Item was not found because printer is not hooked up or is off-line.
3. Drive 1(B) has "not found" message because there is no diskette in it.
4. Drives 2(C) and 3(D) were not found because this system does not contain an extra RX50 drive.
5. Problem here is because disk drive is not formatted yet.

Figure 7-7 System Test Results Sample

The system test diskette displays the following results.

OK

This message means that the test finds nothing wrong with the item tested. You can now return to the user selections menu to remove the system test diskette and resume your work.

This item not found in the system

This message means that the test cannot find the item (or device). Check all the external cable connections. Make sure that external items such as your printer are turned on.

NOTE: *If the item appears in reverse video and this message is displayed, the device is there but not ready. Turn off the system and turn on or plug in the device indicated. Select Run system test again.*

Problem here

This message means that the test finds a problem with the item tested. When you see this message, return to the user selections menu (SET-UP) by making the `Return to Setup` selection on the system test menu. Reboot the system with the diskette still in the drive. This resolves any software error. If there is still a problem, follow this procedure.

1. Record the item(s) and the result(s).
2. Remove the system test diskette and turn off (O) your system.
3. Consult the appropriate section in your *DECmate II Repair Guide* or
4. Call your HELP LINE.

Install new option test on this diskette

This selection allows you to transfer an option test onto the system test diskette. Place the system test diskette in drive 0 (A) and the option diskette in drive 1 (B). Options that you purchase in the future will be shipped with this kind of test. When you choose this selection, the video monitor screen provides instructions to perform the transfer (Figure 7-8).

NOTE: *The name of the option test is printed on the diskette label.*

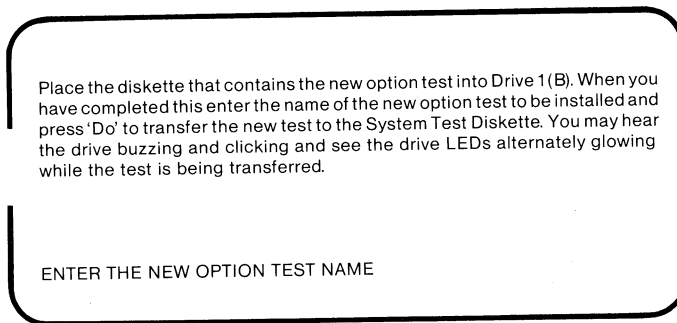

MA-0945-83

Figure 7-8 Install New Option Test Display

If the system has a problem reading the program in drive 1 (B), the following message appears:

```
Syserr -- 3 Error reading drive 1 (B)
PRESS 'DO' TO CONTINUE
```

Make sure you have inserted the diskette correctly. Press **Do** to return to the system test menu and try again. If there is still a problem, the diskette is defective and must be replaced.

```
Return to Setup to change diskette
```

This selection returns you to the user selection menu, allowing you to change diskettes (**Remove** key), change selections, or leave the menu (**Return** key).

```
Format hard disk drive
```

Use this selection to prepare a hard disk for loading application software when you install a new disk or want to reformat a used disk. When reformatting a used disk, you will see the prompt `Are you sure you want to reformat the drive? YES / NO`. You must type the whole word for your response. Also, when reformatting, it is a good idea to run the system test immediately afterward to verify the reformatting process.

Formatting takes about 15 minutes. During this time, the screen twice displays a countdown from 304 to 0. The first countdown occurs during the actual formatting; the second occurs during disk verification.

```
Update internal data on system diskette
```

This selection allows you to copy new revisions of firmware onto the system diskette.

```
Update internal data on hard disk drive
```

This selection allows you to copy new revisions of firmware onto the hard disk.

Power Problems

If your DECmate II suddenly goes off, its power was interrupted. Check to see if its power cord is plugged in. If the lights and other equipment in your area went off at the same time, the power is off in your area. In this event, turn off the DECmate II. Only when you are sure the power is on and steady, turn it back on.

NOTE: *Information can be lost when power is interrupted. Never turn off the DECmate II while it is doing something or you may damage a diskette.*

Momentary power interruptions cause the screen to go blank then come up the way your system software has determined. It is only momentary if you can still hear the sound of the fan and diskette drive(s). Reboot the system and continue.

Sometimes a condition known as a brownout occurs. Brownout happens when the voltage at the outlet is lower than normal. Some brownouts make the DECmate II act the way it does in momentary power interruptions. Less serious brownouts can make it stop responding to your typing. If this happens, wait for full power to be restored before you continue.

Diskette Problems

See Chapter 5 for this information.

Printer Problems

If there is a problem with your printer, consult Table 7-4. Then, if necessary, refer to the printer manuals.

DECmate II Repair Guide

You can purchase this guide if you want to service the DECmate II yourself. It should be used by people who have some training in electronics and who understand the safety requirements involved in working with electrical equipment. The guide is shipped with a system test diskette that provides a system-level checkout with detailed diagnostics. The *DECmate II Repair Guide* provides detailed troubleshooting methods and module replacement procedures.

Table 7-4 Printer-Related Problems

Problem	Probable Cause	What To Do
Printer does not start when DECmate II power switch is on (1).	Printer power switch is off.	Turn switch on.
	Printer's fuse is blown.	Replace if necessary.
	DECmate II does not know printer is on.	Turn on printer. Turn off DECmate II power switch, then turn it on.
	Printer cable is not connected.	Connect cable.
Printer halts unexpectedly.	Printer is out of paper.	Load printer with paper.
	Paper is stuck.	Remove old paper, feed new paper, restart.
	Ribbon is broken.	Change ribbon.
	Mylar™ ribbon is tattered or broken.	File rough edges from ribbon guide.
	End of ribbon.	Change ribbon.
Characters are partially blurred.	Ribbon is not aligned with printhead.	Tap down ribbon.
First character is not printing at beginning of line.	Ribbon is not tight enough.	Adjust ribbon by using knob on ribbon cartridge.
Paper gets caught.		Make sure one bail bar roller is on the left side and two bail bar rollers are on the right side.
Paper does not feed straight.		Clean platen.

™Mylar is a trademark of DuPont de Nemours and Company, Inc.

DIGITAL Service

You can purchase repair and support services from DIGITAL. DIGITAL provides a variety of features that allow you to choose the best type of coverage you require.

This service is described on the inside back cover of this manual. For more information, call one of the DIGITAL service numbers listed there.

When You Use DIGITAL Service

Use the following guidelines to get the most efficient service.

Before You Call for Service.

- Read through Chapter 7. Often you can solve a problem yourself and save yourself the inconvenience of having to wait for a service technician.
- Write down the serial number of your DECmate II. The serial number is on the rear of the system unit next to the power cord.
- Be ready to describe your problem. Note what you were doing when the system failed and if any new sounds or electrical disturbances occurred just before or after the system failed. Your notes will help speed the solution to your problem.

When You Call for Service.

- Be near the system so you and DIGITAL can find the problem quickly.
- Have all of your materials available. The service person may ask you to try to recreate the problem. To do this, you should use the same data and software diskettes that you were using when the problem occurred.

Part 4

Accessories and Supplies

8

Accessories and Supplies

General

This chapter lists some of the accessories and supplies available for the DECmate II system. Consult your local salesperson for a complete listing.

The accessories and supplies are listed according to items of general use and items specifically used with the printers supported by DECmate II: LA50, LA100, and LQP02. Model numbers are included. Ordering information is at the end of this chapter.

Diskettes

● RX50K diskettes, box of 10	RX50K-10
● Diskette binder for storing 20 diskettes, 5-1/4 in	RX50K-DB
Diskette box for storing 50 diskettes, 5-1/4 in	RX50K-DC
Diskette mailer for easy mailing of diskettes, 5-1/4 in, box of 10	RX50K-DM
Diskette stand for storing diskettes, 5-1/4 in	RX50K-DS
Diskette file, 5-1/4 in, box of 10	RX50K-SF
Enclosure Kit	SRXEN-00

Printer Cables

10-ft printer cable	BCC05-10
25-ft printer cable	BCC05-25
50-ft printer cable	BCC05-50

Modems

High-performance direct-connect modem;
300/1200 bits per second;
Bell 212A, 103J compatible

Automatic answer	DF03-AA
Automatic call/answer	DF03-AC

Medium-performance direct-connect modem; 300 bits per second; Bell 212A, 103J compatible; automatic answer	DF02-AA 300
--	-------------

Acoustic coupler modem, 300 bits per second, can be used with standard telephone headset	DF01-AA
---	---------

Modem Cables

10-ft modem cable	BCC04-10
25-ft modem cable	BCC04-25
50-ft modem cable	BCC04-50

LA50 Printer

Ribbons

Box of 6 ribbon cartridges LA50R-06

Paper

9-1/2 in × 11 in, 1/2-in green and white bar fanfold, 3500 sheets/box H9850-PV

9-1/2 in × 11 in blank, single-part white, 1/2-in perforated edges, 2700/box H9850-PH

9-1/2 in × 11 in blank, 2-part carbonless, 1/2-in perforated edges, 1750 sheets/box H9850-PJ

9-1/2 in × 11 in blank, 2-part carbon, 1/2-in perforated edges, 750 sheets/box H9850-PR

LA100 Printer

Accessories

Printer stand	LA10X-SL
Paper catcher (for use with printer stand)	LAX34-SP
Paper shelf (for use with printer stand)	LAX34-SQ
Paper tray (for use on printer)	LAX34-SW
Cut sheet feeder	LA10X-SF
Forms tractor	LAX34-AL
Dust cover for LA100 without tractor	H9850-HA
Dust cover for LA100 with tractor	H9850-HB

Ribbons

Box of 6 ribbons LA10R-06

Paper

9-1/2 in × 11 in blank, single-part white,
1/2-in perforated edges, 2700 sheets/box H9850-PH

9-1/2 in × 11 in green and white bar,
fanfold, 3500 sheets/box H9850-PV

14-7/8 in × 11 in green and white bar,
fanfold 132 column, 2600 sheets/box H9850-PA

9-1/2 in × 11 in blank, 2-part carbonless,
1/2-in perforated edges, 1750 sheets/box H9850-PJ

Fonts

Courier 10 ROM cartridge	LA10X-AA
Courier 12 ROM cartridge	LA10X-AB
Gothic 12 ROM cartridge	LA10X-AC
Orator 10 ROM cartridge	LA10X-AD
Courier 10 plug-in ROM	LA10X-CA
Courier 12 plug-in ROM	LA10X-CB
Gothic 12 plug-in ROM	LA10X-CC
Orator 10 plug-in ROM	LA10X-CD
LA100 multiple font option	LA10X-FL

LQP02 Printer

Accessories

Printer stand	H9850-AT
Caster for printer stand	H9850-AV
Binder-like case that securely holds 6 print wheels	LQPX2-PC
Cut sheet feeder	LQPX2-SF
Forms tractor	LQPX2-AA

Ribbons in boxes of 6

● Multistrike Mylar ribbon, high-quality impression, single loop. Sensor stops printer at ribbon's end before characters are lost.	LQP02-KA
Fabric ribbon, continuous-loop. Use until desired type quality can no longer be obtained.	LQP02-KB

Paper

● 9-1/2 in × 11 in blank, single-part white, 1/2-in perforated edges, 2700 sheets/box	H9850-PH
9-1/2 in × 11 in blank, 2-part carbonless, 1/2-in perforated edges, 1750 sheets/box	H9850-PJ
9-1/2 in × 11 in blank, 4-part carbonless, 1/2-in perforated edges, 1750 sheets/box	H9850-PK
9-1/2 in × 11 in blank, 2-part carbon, 1/2-in perforated edges, 750 sheets/box	H9850-PR
9-1/2 in × 11 in blank, 4-part carbon, 1/2-in perforated edges, 750 sheets/box	H9850-PS

Print wheels in boxes of 6

UKN Letter Gothic 12	LQP02-MB
WP Courier 10	LQP02-MD
WP Pica 10	LQP02-ME
Ⓢ WP Prestige Elite 12	LQP02-MF
Bilingual Courier 10	LQP02-MH
Bilingual Prestige Elite 12	LQP02-MJ
WP Orator 90% 10	LQP02-MK
ANSI OCR-B 10	LQP02-ML
WP Theme 11 Pt PS	LQP02-MM
WP Letter Gothic 12	LQP02-MS
WP Gothic 15	LQP02-MT
ASC 11 96 Prestige Elite 12	LQP02-MV
WPS Boldface PS	LQP02-MW
WPS Title PS	LQP02-MX
WPS Thesis PS	LQP02-MY
WPS Boldface Italic PS	LQP02-NA
Dual Courier 10	LQP02-NC

Ordering Information

You can obtain ordering information by telephone from 8:30 a.m. to 6:00 p.m. or by mail.

Continental USA and Puerto Rico

1-800-258-1710

New Hampshire, Alaska, Hawaii

1-603-884-6660

In the USA and Puerto Rico

Digital Equipment Corporation
PO Box CS2008
Nashua, New Hampshire 03061

Outside the USA and Puerto Rico

Digital Equipment Corporation
Attn: Accessories and Supplies Business Manager
c/o Local Subsidiary or DIGITAL-Approved Distributor

A

Specifications

Dimensions

System unit

Height	16.5 cm (6.5 in)
Length	48.3 cm (19 in)
Width	36.3 cm (14.3 in)

Video monitor

Height	29.2 cm (11.5 in)
Width	34.9 cm (13.75 in)
Depth	31.1 cm (12.25 in)

Keyboard

Height	5 cm (2 in) maximum, including keycaps
Length	53.3 cm (21 in)
Width	17.1 cm (6.75 in)

Weight

System unit	13.6 kg (30 lb)
Video monitor	6.4 kg (14 lb)
Keyboard	2 kg (4.5 lb)

Processor

CPU	6120 custom CMOS
Word size	12 bits
Memory	64K words
Instruction set	Extended PDP-8
Speed	8 MHz (I/O 4 MHz)
Controllers	Floppy, video, printer, communications, keyboard controllers on system board

Display

CRT	31-cm (12-in) diagonal, black-and-white
Format	24 lines \times 80 characters or 24 lines \times 132 characters
Character	7 \times 9 dot matrix with descenders
Character attribute	Bold, blink, underline, reverse
Character type	Normal, double-height, double-width
Screen	Normal, reverse
Scrolling	Fast, slow
Performance	Full screen update in less than 0.1 s

Keyboard

General	105-key detachable unit with 1.9 m (6 ft) coiled cord
Key layout	57-key arrangement similar to standard typewriter; keyboard with 18-key keypad and 10-key cursor control key group; and 20 special function keys
Auxiliary keypad	18-key editing and numeric pad with period, comma, minus, enter, and four general-purpose keys
Visual indicators	Four LEDs: Hold Screen, Lock, Compose, Wait
Audible signals	Keyclick: simulated typewriter bell

Communications

Factory setting of communication port	1200
Description	Single line, asynchronous/synchronous byte and bit protocols; full modem control; meets EIA standards RS232-C and RS423-A

Printers

Factory settings

LA50	4800 baud, no parity, 8 data bits, 1 stop bit
LA100	4800 baud, no parity, 8 data bits, 1 stop bit
LQP02	4800 baud, space parity, 8 data bits, 1 stop bit

RX50 Diskette Drive

Number of drives	One 5-1/4 in drive
Number of surfaces	Two; one drive holds two independently removable diskettes
Capacity of drive	400K bytes 800K bytes with two diskettes
Expansion	Second drive within same system unit gives 1.6 megabytes
Transfer rate	250K bits per second

Hard Disk Drive

Capacities (values in decimal)

Words per sector	256 (12 bits wide)/512 8-bit bytes
Sectors per track	16 ₁₀ /20 ₈ <0:17 ₈ >
Total capacity	10 megabytes

NOTE: *Cylinder 0 of all surfaces is reserved for system startup code and self-test use. This cylinder, therefore, should not be made available for general use.*

Transfer rate	10 to 20 microseconds per word
---------------	--------------------------------

Environment

Temperature	15°–32°C (59°–90° F)
Humidity	20%–80% relative humidity
Maximum wet bulb	25° C (77° F)
Minimum dew point	2° C (36° F)

Power

AC input	Factory set
115 V nominal	Single-phase, 3-wire, 90–128 V rms, 47–63 Hz line frequency or
230 V nominal	Single-phase, 3-wire, 174–256 V rms, 47–63 Hz line frequency
Line current	3 A at 115 Vac or 1.5 A at 230 Vac
AC power consumption	218 W, including fan
Regulated voltages	+ 5 V, + 12 V, – 12 Vdc
Circuit protection	Circuit breaker, externally accessible

Glossary

accessories and supplies

Items such as print wheels and paper available to the DECmate II user.

baud

Unit of signal speed for information traveling through a cable between a computer and another device such as a printer, modem, or another computer.

bit (*binary digit*)

Smallest possible piece of information that the computer processes. Can have only two possible values, 0 and 1.

boot

To load an operating system into the system's memory.

buffer

Temporary storage space in a computer.

byte

Several bits grouped together for convenience in transmitting and receiving.

central processing unit (CPU)

Electronic components in a computer that monitor and control operations among the various parts of the computing system.

character

Single letter, numeral, or symbol used to represent data. Can include space, tab, or carriage return.

circuit breaker

Recessed knob on the rear of the system unit that pops out under power overload conditions.

code

Arrangement of signals that carry meaning to the system.

command

User instruction that causes the computer system to perform an operation.

component

One of the main parts of the DECmate II such as a keyboard or a printer.

control

Code that affects the recording, processing, transmission, or interpretation of other information that is sent to a system.

cursor

Movable, blinking marker on the video monitor screen that defines the next point of character entry or change.

data

Information used, created, or processed by an application program.

data bit

Bit that carries data information in a serial stream as opposed to stop or parity bits, which carry control information.

diagnostic

Program that detects and isolates malfunctions and errors and reports its findings.

diskette

Flexible, 5-1/4 inch plastic disc permanently enclosed in a protective cover that stores operating systems, documents, and diagnostics.

diskette drive

Device that acts like a tape recorder in that it reads and records information on diskettes.

drive 0 (A)

Upper door of RX50 diskette drive when system unit rests in a horizontal position.

drive 1 (B)

Lower door of RX50 diskette drive when system unit rests in a horizontal position.

drive 2 (C)

Upper door of RX50 diskette drive of optional second drive when system unit rests in a horizontal position.

drive 3 (D)

Lower door of RX50 diskette drive of optional second drive when system unit rests in a horizontal position.

drive E

Part of CP/M error message that refers to hard disk drive.

hard disk

A permanently sealed, nonremovable, reusable disk in the hard disk drive, an optional subsystem of the DECmate II. Like a diskette, it provides storage space for software applications equivalent to 25 or more diskettes.

hardware

Physical equipment of a computer system. The mechanical, electrical, and electronic parts.

hardwired

State of the computing system in which it is permanently connected to another computer via a cable.

host computer

Computer that controls the network or system operation.

initialize

To ready the internal circuits for operation at power-up.

K

Symbol for the quantity 2 to the 10th power, or 1,024.

keycap

Nonremovable key covering that identifies the key's function.

keyclick

Sound that comes from the keyboard when all keys except **Shift** and **Ctrl** are pressed.

LED (light emitting diode)

Small round lamp that glows. Acts as a signal from the computer.

linefeed

Action in which the last line of text moves up one whole line. User's relative position (marked by the cursor) has moved forward one whole line.

M

Symbol for the quantity 2 to the 20th power, or 1,048,578.

memory

Reference file in the computer where relatively large quantities of information are stored.

mode

Condition or state of operating. Different modes allow different kinds of operations to be performed.

modem (*modulator-demodulator*)

Small device used to allow computers to communicate with each other via the telephone lines.

module

Complete assembly that is a subsection of a larger system, for example, a power supply or keyboard.

multiplexer

Device that sends two or more signals at the same time over a common transmission medium.

operating system

Collection of programs that controls the overall operations of a computer.

option

Item available to enhance the function of a basic system, for example, a CP/M board.

parity

One-extra-bit code used to detect transmission errors by making the total number of 1 bits in a unit of data odd or even.

port

Physical or figurative part of the system where the computer makes a connection with an external device.

power supply

Module that converts ac power into dc power that can be used by DECmate II.

power switch

Part of the system unit that turns the system on (1) and off (0).

reboot

To start system operation again.

register

Circuit for the storage of data for a short period of time.

reset

To return equipment to its original state.

reverse video

Display feature that produces the opposite combination of characters and background from that which is usually used.

scroll

To move lines of text of a display image up or down for the purpose of viewing or adding to the text.

SET-UP

Condition of the system in which operating features can be selected or modified.

software

Stored programs or routines that direct the activities of the computer.

status

The condition or rating of the system at any particular time.

stop bit

Bit that carries control information in a serial stream.

system board

Printed circuit board that contains the central processing unit and electronic circuits that control the rest of the DECmate II system.

system unit

Component that contains the system board, option boards when present, power supply, diskette drive, and fan and power switch assembly.

terminal emulation

Feature of operation in which one system acts as a system of a different design.

troubleshooting

Deductive process of finding reason for and source of problems.

video monitor

Component that displays on its screen the user text and any menus or other information generated by the operating system.

word processing system

System that processes text and performs such functions as paragraphing, paging, margin justifying, rearranging of lines and printing.

Index

A

- Accessories, 97
- Application diskette
 - See* document diskette
- APU test LED, 5
- Arrow keypad, 54

B

- Backspace key, 56
- Baud rate
 - See also* user selections
 - Changing via user selections menu, 73, 74
 - Communications port setting, Table 3-1 (39), 45
 - Definition, 38
 - Hardwiring, 45
 - Printer port setting, 38, Table 3-1 (39)
- Bell tone, 59
- Break key, 56

C

- Cables
 - List and description, 26–28
 - Modem, 28, 43
 - Null modem (hardwiring), 45
 - Printer, 28, 38

- System board, Figure 1-12 (11)
- Circuit breaker
 - Description, 4
 - If it pops out, 86
- Communications
 - Baud rates, user selections menu, 73
 - Cables, 28
 - Connector on system unit, 5
 - Dial-up telephone lines, 41
 - Leased or private line, 46
 - Specifications, 107
- Compose Character key, 53
- Compose LED, 58
- Connector panel, 5
- Control key, 52
- Cover removal
 - See DECmate II Installation Guide*
- CP/M board
 - Description, 17
 - RX01/RX02 board with, 35
 - Self-Test LED (APU Test LED), 5
- CP/M designations on drive doors, 62
- CPU (central processing unit), 9
 - See also* processor
- Cursor
 - See also* arrow keypad
 - Definition, 49
 - Moving in user selections menu, 74
 - Styles, 73
 - Visibility, 73

D

Data format

Definition, 39

Settings, Table 3-1 (39)

DIGITAL service, 95, inside back cover

Diskette

Description, 61, Figure 5-2 (63)

5-1/4 inch, 63

8 inch, 63

Handling, 64

Inserting, 65, 71

Ordering, 103

Preventing problems, 67

Problems related to, 67

Storing, 31

Types, 61

Diskette drive

See also RX50 diskette drive

Door designations, 62

Door, how to open, 65

LEDs, 14

Display messages

See also video monitor

Self-test, 79-81

User selections menu, 73

System test, 87-91

Do key

Command key function, 48

Description, 57

Used in user selections menu, 73-75

Document diskette

Definition, 62

Preventing problems with, 67

E

Editing keypad, 53

Electrical power

See power

Environment

Guidelines, 29-32

Specifications, 109

Error messages, 80, Table 7-1 (82), Table 7-2 (83)

See also display messages, self-test

Escape key, 56

F

Fan

See also power switch and fan assembly

Connectors, 15

Description, 15

Dust particles, 31

Failure, 78

Location, Figure 1-8 (8), Figure 1-15 (15)

Warning: high voltages, 15

Floppy

See diskette

G

Greater than/Less than key, 52

H

Hard disk drive subsystem

Description, 20

Installation, 36

Use, 38

Hardwiring, 45

Help key, 57

HELP LINE, 78

Hold Screen key, 55

Hold Screen LED, 58

Host computer, connecting to, 45

Hyphen Push/Hyphen Pull key, 57

I

Installation

Options, 33

System, *see* DECmate II Installation Guide

K**Keyboard**

- Description, 6, 47
- Cable, 26
- Caring for, 32
- Connecting cable, 47
- Indicators, 58
- Keyclick, 59
- Specifications, 107

Keyclick

- See also* user selections
- Description, 59

L**LA50 printer, 22**

- See also* printer

LA100 printer, 22

- See also* printer

Linefeed key, 57**Lock key, 52****Lock LED, 58****LQP02 printer, 22**

- See also* printer

M**Main keyboard, 51**

- See also* keyboard

Maintenance of system, 32**Modems**

- Cables, Figure 1-25 (27), 28, 43
- Connecting, 43
- Description, 25

N**Null modem cable, 45****Number on screen**

- See* error messages

Numeric keypad, 54**O****Options**

- Attaching, 33–46
- Description, 16–26
- Ordering information, 103

P**Parity**

- See* data format

Plastic adapter plate for RX01/RX02 option, 5**Power**

- Problems, 93
- Requirements, 12, 30
- Specifications, 109

Power cord, 4**Power supply**

- Cables, 12
- Connectors, Figure 1-13 (13)
- Location, Figure 1-8 (8)

Power switch

- See also* power switch and fan assembly
- Description, 15
- Location, Figure 1-2 (3), Figure 1-8 (8)
- Rebooting system, 86
- Turning on DECmate II, 77

Power switch and fan assembly

- Cables, 12
- Description, 15, Figure 1-15 (15)

Power self-test

- Description, 79
- Error codes, Table 7-1 (82), Table 7-2 (83)
- Indicators, Table 7-3 (85)
- Messages, 79–81

Print Screen key, 55**Print wheels, 102**

Printer

- Accessories and supplies, 98–102
- Cable, 28
- Connecting to DECmate II, 38
- Connector, 5, Figure 1-5 (5)
- Problems, 90, Table 7-4 (94)
- Specifications, 108

Problems

- Diagnosing, with system test diskette, 62, 87
- Power, 93
- Preventing, with diskettes, 67
- Printer, 93, Table 7-4 (94)
- What to do first, 86

Processor, 106

R

Rebooting, 86

Remove key

- Functional group, 54
- Used in user selections menu, 73, 75

Repair guide, 93

Repair of system, 95

Repair service

- See* DIGITAL service

Return key

- Description, 51
- Used in user selections menu, 73, 74

Ribbons, 99, 101

Rubout key

- See* Word/Character key

RX01/RX02 board

- Cable, Figure 1-25 (27), 28
- Connecting, 33
- Data transfers, 63
- Description, 18
- Restrictions when using, 35

RX50 diskette drive

- Description, 14
- Door designations, 62
- Second (option), 19
- Specifications, 108

S

Screen

- See* display, video monitor
- See also* user selections
- Mode, 73
- Width, 73

Scrolling, 73

- See also* user selections

Second RX50 diskette drive

- See* RX50 diskette drive

Select key

- Functional group, 54
- Used in user selections menu, 73, 74

SET-UP features

- See* user selections

Set-up key, 56

Shift key, 48, 52

Short-haul modem, 46

Space bar, 53

Special function keys, 54

Supplies

- Ordering, 103
- Storing, 31

System board

- Description, 9
- Detachable cables, Figure 1-12 (11)

System diskette

- Description, 62
- Exchanging for another, 67, 75

System test diskette

- Description, 62, 87
- Messages, 88–92

System unit

- Caring for, 31
- Connectors, 5
- Cover removal, 2
- Description, 2, Figure 1-2 (3), 8, Figure 1-8 (8)
- Floor stand, installed in, 21, 29
- LED, 5
- Modules, 8
- Power cord, 26

T

Tab key, 51
Terminal mode, 73
 See also user selections
Troubleshooting, 77
Turning on DECmate II, 69

U

User selections
 Menu, 73
 Using selections menu, 74, 75

V

Vertical floor stand, 21
Video monitor
 See also display messages
 Cable, 26
 Caring for, 32
 Description, 6, Figure 1-7 (7)
 Display specifications, 106
Voltage selection switch, 4

W

Wait LED, 58
Word/Character key (rubout), 51
WPS
 Drive door designations, 62
 Specific keys, 48, 53, 57
Write-protect notch, 63

Your comments and suggestions will help us in our continuous effort to improve the quality and usefulness of our publications.

What is your general reaction to this manual?

	Excellent	Very Good	Good	Fair	Poor
Accuracy	<input type="checkbox"/>	<input type="checkbox"/>	<input type="checkbox"/>	<input type="checkbox"/>	<input type="checkbox"/>
Completeness	<input type="checkbox"/>	<input type="checkbox"/>	<input type="checkbox"/>	<input type="checkbox"/>	<input type="checkbox"/>
Organization	<input type="checkbox"/>	<input type="checkbox"/>	<input type="checkbox"/>	<input type="checkbox"/>	<input type="checkbox"/>
Format	<input type="checkbox"/>	<input type="checkbox"/>	<input type="checkbox"/>	<input type="checkbox"/>	<input type="checkbox"/>

What features are most useful?
(Notes, Tables, Illustrations, etc.) _____

Does the publication satisfy your needs? Yes No

What errors have you found?
(Ref. page no., table no., figure no.) _____

Additional Comments _____

Name _____ Street _____
Title _____ City _____
Company _____ State/Country _____
Department _____ Zip _____

The Documentation Products Directory and the DECdirect Guide contain information on the remainder of DIGITAL's technical documentation.

Copies of the above Directory and Guide, as well as additional copies of this document, are available by writing or calling:

Digital Equipment Corporation
Accessories and Supplies Group
P.O. Box CS2008
Nashua, New Hampshire 03061

Attention: Documentation Products
Telephone: 1-800-258-1710

Order No. EK-DECM2-OM-002

MY

DO NOT TEAR - FOLD HERE AND TAPE

digital



No Postage
Necessary
if Mailed in the
United States

BUSINESS REPLY MAIL

FIRST CLASS

PERMIT NO. 33

MAYNARD, MA.

POSTAGE WILL BE PAID BY ADDRESSEE

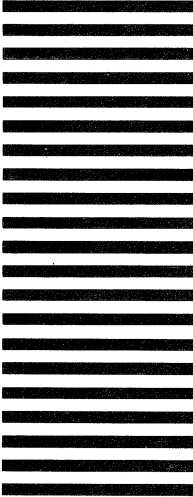

DIGITAL EQUIPMENT CORPORATION
EDUCATIONAL SERVICES/QUALITY ASSURANCE
12 CROSBY DRIVE, BU/E08
BEDFORD, MA 01730

INSTALLATION, WARRANTY, AND SERVICE INFORMATION

INSTALLATION/WARRANTY

If you have purchased directly from Digital, refer to the sales agreement for installation and warranty terms purchased with your system.

If you have purchased, leased, or rented from a vendor other than Digital, contact your vendor for information regarding installation and warranty terms.

DIGITAL SERVICES

Digital provides a wide range of maintenance programs to meet your service needs, from complete Digital support to complete self-maintenance.

On-Site Service

For quality maintenance performed at your site, you can choose from DECservice, Basic Service Agreements, or Time and Materials Service.

System Support Agreement

This agreement includes a HELP LINE, software updates, and on-site and carry-in hardware support.

Carry-in Service

This is "return-to" maintenance at a considerable savings over on-site service.

DECmailer

If you perform your own maintenance, you should use our fast-turnaround, module-and-subassembly repair service called DECmailer.

For more information on any of Digital's maintenance services, call the Digital Field Service information number in your area during normal business hours.

USA (Mainland)	(800) - DEC-8000	Italy	(02) 617 53 81 or/82
USA (Alaska, Hawaii)	(404) - 953-0552	Japan	(0424) - 64-3302
Austria	(222) - 67 76 41, ext. 444	Norway	(02) - 25 64 22
Belgium	(02) - 24 26 790	South Pacific Region (Sidney)	(02) 412-5555
Canada	(800) - 267-5251	South Pacific Region (Other)	(008) 226377
Denmark	(04) - 30 10 05	Spain	(1) - 73 34 307
Finland	(90) - 42 33 32	Sweden	(08) - 98 88 35
France	(1) - 687 31 52	Switzerland	(01) - 810 51 21
Germany	(08)9 - 95 91 66 44	United Kingdom	(0256) - 59 200
Holland	(1820) - 31 100		

Training

Digital offers hardware maintenance courses at 17 worldwide training centers or your own facilities.

Spare Parts

If you perform your own maintenance, Customer Spares provides Spares Inventory Planning, Maintenance Test Equipment and Documentation, and Emergency Spare Parts.