



# AlphaPC 164SX Motherboard

---

## Technical Reference Manual

Order Number: EC-R57EB-TE

**Revision/Update Information:** This is a revised document. It supersedes the *AlphaPC 164SX Motherboard Technical Reference Manual*, EC-R57EA-TE.

Compaq Computer Corporation

---

**October 1998**

The information in this publication is subject to change without notice.

COMPAQ COMPUTER CORPORATION SHALL NOT BE LIABLE FOR TECHNICAL OR EDITORIAL ERRORS OR OMISSIONS CONTAINED HEREIN, NOR FOR INCIDENTAL OR CONSEQUENTIAL DAMAGES RESULTING FROM THE FURNISHING, PERFORMANCE, OR USE OF THIS MATERIAL. THIS INFORMATION IS PROVIDED "AS IS" AND COMPAQ COMPUTER CORPORATION DISCLAIMS ANY WARRANTIES, EXPRESS, IMPLIED OR STATUTORY AND EXPRESSLY DISCLAIMS THE IMPLIED WARRANTIES OF MERCHANTABILITY, FITNESS FOR PARTICULAR PURPOSE, GOOD TITLE AND AGAINST INFRINGEMENT.

This publication contains information protected by copyright. No part of this publication may be photocopied or reproduced in any form without prior written consent from Compaq Computer Corporation.

©1998 Compaq Computer Corporation. All rights reserved. Printed in U.S.A.

AlphaPC, COMPAQ, DECchip, DIGITAL, DIGITAL UNIX, the Compaq logo, and the DIGITAL logo registered in United States Patent and Trademark Office.

Altera is a registered trademark of Altera Corporation.

Cypress and hyperCache are trademarks of Cypress Semiconductor Corporation.

GRAFOIL is a registered trademark of Union Carbide Corporation.

IEEE is a registered trademark of The Institute of Electrical and Electronics Engineers, Inc.

Intel is a registered trademark of Intel Corporation.

Microsoft and Visual C++ are registered trademarks and Windows NT is a trademark of Microsoft Corporation.

SMC and Standard Microsystems are registered trademarks of Standard Microsystems Corporation.

UNIX is a registered trademark in the United States and other countries, licensed exclusively through

X/Open Company Ltd.

Other product names mentioned herein may be trademarks and/or registered trademarks of their respective companies.

---

# Contents

## Preface

## 1 Introduction

1.1	System Components and Features .....	1-1
1.1.1	21174 Core Logic Chip .....	1-3
1.1.2	Memory Subsystem .....	1-3
1.1.3	L2 Bcache Subsystem Overview .....	1-4
1.1.4	PCI Interface Overview .....	1-4
1.1.5	ISA Interface Overview .....	1-4
1.1.6	Miscellaneous Logic .....	1-5
1.2	Software Support .....	1-5
1.2.1	AlphaBIOS Windows NT Firmware .....	1-5
1.2.2	Alpha SRM Console Firmware .....	1-6
1.2.3	Motherboard Software Developer's Kit (SDK) .....	1-6
1.3	Hardware Design Support .....	1-6

## 2 System Configuration and Connectors

2.1	AlphaPC 164SX Configuration Switches .....	2-4
2.2	CPU Speed Selection (CF[6:4]) .....	2-4
2.3	Bcache Size Switches (CF0 and CF1) .....	2-5
2.4	Password Bypass (CF2) .....	2-5
2.5	Fail-Safe Booter (CF7) .....	2-5
2.6	Mini-Debugger (CF3) .....	2-6
2.7	AlphaPC 164SX Connector Pinouts .....	2-6
2.7.1	PCI Bus Connector Pinouts .....	2-6
2.7.2	ISA Expansion Bus Connector Pinouts .....	2-8
2.7.3	SDRAM DIMM Connector Pinouts .....	2-9
2.7.4	EIDE Drive Bus Connector Pinouts .....	2-10
2.7.5	Diskette (Floppy) Drive Bus Connector Pinouts .....	2-11
2.7.6	Parallel Bus Connector Pinouts .....	2-11

2.7.7	COM1/COM2 Serial Line Connector Pinouts . . . . .	2-12
2.7.8	Keyboard/Mouse Connector Pinouts . . . . .	2-12
2.7.9	SRAM Test Data Input Connector Pinouts . . . . .	2-13
2.7.10	Input Power Connector Pinouts . . . . .	2-13
2.7.11	Enclosure Fan Power Connector Pinouts . . . . .	2-13
2.7.12	Microprocessor Fan Power Connector Pinouts . . . . .	2-14
2.7.13	Soft Power Connector Pinouts . . . . .	2-14
2.7.14	Multipurpose Connector Pinouts . . . . .	2-14

### 3 Power and Environmental Requirements

3.1	Power Requirements . . . . .	3-1
3.2	Environmental Requirements . . . . .	3-2
3.3	Board Dimensions . . . . .	3-2
3.3.1	ATX Hole Specification . . . . .	3-3
3.3.2	ATX I/O Shield Requirements . . . . .	3-4

### 4 Functional Description

4.1	AlphaPC 164SX Bcache Interface . . . . .	4-2
4.2	21174 Core Logic Chip . . . . .	4-3
4.2.1	21174 Chip Overview . . . . .	4-3
4.2.2	Main Memory Interface . . . . .	4-4
4.2.3	PCI Devices . . . . .	4-5
4.2.4	PCI/ISA Bridge Chip . . . . .	4-6
4.2.5	PCI Expansion Slots . . . . .	4-6
4.3	ISA Bus Devices . . . . .	4-6
4.3.1	Combination Controller Chip . . . . .	4-7
4.3.2	ISA Expansion Slots . . . . .	4-8
4.3.3	ISA I/O Address Map . . . . .	4-8
4.3.4	Flash ROM Address Map . . . . .	4-9
4.4	Interrupts . . . . .	4-9
4.5	System Clocks . . . . .	4-12
4.6	Reset and Initialization . . . . .	4-14
4.7	DC Power Distribution . . . . .	4-15
4.8	Serial ROM and Debug Port Support . . . . .	4-16

### 5 Upgrading the AlphaPC 164SX

5.1	Configuring SDRAM Memory . . . . .	5-1
5.2	Upgrading SDRAM Memory . . . . .	5-2
5.3	Increasing Microprocessor Speed . . . . .	5-3
5.3.1	Preparatory Information . . . . .	5-3

5.3.2	Required Tools . . . . .	5-3
5.3.3	Removing the 21164PC Microprocessor . . . . .	5-4
5.3.4	Installing the 21164PC Microprocessor . . . . .	5-4

## **A Support, Products, and Documentation**

A.1	Customer Support . . . . .	A-1
A.2	Supporting Products . . . . .	A-2
A.2.1	Memory . . . . .	A-2
A.2.2	Thermal Products . . . . .	A-2
A.2.3	Power Supply . . . . .	A-2
A.2.4	Enclosure . . . . .	A-3
A.3	Alpha Products . . . . .	A-3
A.4	Alpha Documentation . . . . .	A-4
A.5	Third-Party Documentation . . . . .	A-5

## **Index**

## Figures

1-1	AlphaPC 164SX Functional Block Diagram . . . . .	1-2
2-1	AlphaPC 164SX Switch/Connector/Component Location . . . . .	2-2
2-2	AlphaPC 164SX Configuration Switches . . . . .	2-4
2-3	Multipurpose Connector Pinouts . . . . .	2-15
3-1	ATX Hole Specification . . . . .	3-3
3-2	ATX I/O Shield Dimensions . . . . .	3-4
4-1	AlphaPC 164SX L2 Bcache Array . . . . .	4-2
4-2	Main Memory Interface . . . . .	4-3
4-3	AlphaPC 164SX PCI Bus Devices . . . . .	4-5
4-4	AlphaPC 164SX ISA Bus Devices . . . . .	4-8
4-5	Interrupt Request Register . . . . .	4-10
4-6	AlphaPC 164SX System Clocks . . . . .	4-13
4-7	System Reset and Initialization . . . . .	4-14
4-8	AlphaPC 164SX Power Distribution . . . . .	4-15
5-1	Fan/Heat-Sink Assembly . . . . .	5-5

## Tables

1-1	AlphaPC 164SX SDRAM Memory Configurations . . . . .	1-3
2-1	AlphaPC 164SX Switch/Connector/Component List . . . . .	2-3
2-2	PCI Bus Connector Pinouts . . . . .	2-6
2-3	ISA Expansion Bus Connector Pinouts (J22, J23) . . . . .	2-8
2-4	SDRAM DIMM Connector Pinouts (J7 through J10) . . . . .	2-9
2-5	EIDE Drive Bus Connector Pinouts (J5, J6) . . . . .	2-10
2-6	Diskette (Floppy) Drive Bus Connector Pinouts (J11) . . . . .	2-11
2-7	Parallel Bus Connector Pinouts (J13) . . . . .	2-11
2-8	COM1/COM2 Serial Line Connector Pinouts (J3) . . . . .	2-12
2-9	Keyboard/Mouse Connector Pinouts (J4) . . . . .	2-12
2-10	SRROM Test Data Input Connector Pinouts (J21) . . . . .	2-13
2-11	Input Power Connector Pinouts (J2) . . . . .	2-13
2-12	Enclosure Fan (+12 V dc) Power Connector Pinouts (J16) . . . . .	2-13
2-13	Microprocessor Fan Power Connector Pinouts (J14) . . . . .	2-14
2-14	Soft Power Connector Pinouts (J1) . . . . .	2-14
2-15	Multipurpose Connector Pinouts (J20) . . . . .	2-14
3-1	Power Supply DC Current Requirements . . . . .	3-1
3-2	AlphaPC 164SX Motherboard Environmental Requirements . . . . .	3-2
4-1	ISA I/O Address Map . . . . .	4-8
4-2	AlphaPC 164SX System Interrupts . . . . .	4-10
4-3	ISA Interrupts . . . . .	4-11
5-1	AlphaPC 164SX SDRAM Memory Configurations . . . . .	5-2



---

# Preface

## Overview

This manual describes the AlphaPC 164SX motherboard, a board for computing systems based on the Alpha 21164PC microprocessor and the 21174 core logic chip.

## Audience

This manual is intended for system designers and others who use the AlphaPC 164SX motherboard to design or evaluate computer systems based on the Alpha 21164PC microprocessor and the 21174 core logic chip.

## Scope

This manual describes the features, configuration, functional operation, and interfaces of the AlphaPC 164SX motherboard. This manual does not include specific bus specifications (for example, PCI or ISA buses). Additional information is available in the AlphaPC 164SX schematics, program source files, and the appropriate vendor and IEEE specifications. See Appendix A for information on how to order related documentation and obtain additional technical support.

## Manual Organization

As outlined on the next page, this manual includes the following chapters, appendices, and an index.

- Chapter 1, Introduction, is an overview of the AlphaPC 164SX motherboard, including its components, features, and uses.
- Chapter 2, System Configuration and Connectors, describes the user-environment configuration, board connectors and functions, and switch functions. It also identifies switch settings and connector locations.
- Chapter 3, Power and Environmental Requirements, describes the AlphaPC 164SX power and environmental requirements and provides board dimensions.
- Chapter 4, Functional Description, provides a functional description of the AlphaPC 164SX motherboard, including the 21174 core logic chip, L2 backup cache (Bcache) and memory subsystems, system interrupts, clock and power subsystems, and peripheral component interconnect (PCI) and Industry Standard Architecture (ISA) devices.
- Chapter 5, Upgrading the AlphaPC 164SX, describes how to upgrade the AlphaPC 164SX motherboard's SDRAM memory and microprocessor speed.
- Appendix A, Support, Products, and Documentation, lists sources for components and accessories not included with the AlphaPC 164SX motherboard and describes how to obtain information and technical support, and how to order products and associated literature.

## Conventions

This section defines product-specific terminology, abbreviations, and other conventions used throughout this manual.

### Abbreviations

- Register Access

The following list describes the register bit and field abbreviations:

<b>Bit/Field Abbreviation</b>	<b>Description</b>
RO (read only)	Bits and fields specified as RO can be read but not written.
RW (read/write)	Bits and fields specified as RW can be read and written.
WO (write only)	Bits and fields specified as WO can be written but not read.

- **Binary Multiples**

The abbreviations K, M, and G (kilo, mega, and giga) represent binary multiples and have the following values.

K	=	$2^{10}$	(1024)
M	=	$2^{20}$	(1,048,576)
G	=	$2^{30}$	(1,073,741,824)

For example:

2KB	=	2 kilobytes	=	$2 \times 2^{10}$	bytes
4MB	=	4 megabytes	=	$4 \times 2^{20}$	bytes
8GB	=	8 gigabytes	=	$8 \times 2^{30}$	bytes

## **Addresses**

Unless otherwise noted, all addresses and offsets are hexadecimal.

### **Bit Notation**

Multiple-bit fields can include contiguous and noncontiguous bits contained in brackets ([ ]). Multiple contiguous bits are indicated by a pair of numbers separated by a colon (:). For example, [9:7,5,2:0] specifies bits 9,8,7,5,2,1, and 0. Similarly, single bits are frequently indicated with brackets. For example, [27] specifies bit 27.

### **Caution**

Cautions indicate potential damage to equipment, software, or data.

### **Data Field Size**

The term INT $nn$ , where  $nn$  is one of 2, 4, 8, 16, 32, or 64, refers to a data field of  $nn$  contiguous NATURALLY ALIGNED bytes. For example, INT4 refers to a NATURALLY ALIGNED longword.

### **Data Units**

The following data-unit terminology is used throughout this manual.

<b>Term</b>	<b>Words</b>	<b>Bytes</b>	<b>Bits</b>	<b>Other</b>
Byte	½	1	8	—
Word	1	2	16	—
Longword/Dword	2	4	32	Longword

<b>Term</b>	<b>Words</b>	<b>Bytes</b>	<b>Bits</b>	<b>Other</b>
Quadword	4	8	64	2 Longwords
Octaword	8	16	128	2 Quadwords
Hexword	16	32	256	2 Octawords

### **Note**

Notes emphasize particularly important information.

### **Numbering**

All numbers are decimal or hexadecimal unless otherwise indicated. The prefix 0x indicates a hexadecimal number. For example, 19 is decimal, but 0x19 and 0x19A are hexadecimal (also see Addresses). Otherwise, the base is indicated by a subscript; for example,  $100_2$  is a binary number.

### **Ranges and Extents**

Ranges are specified by a pair of numbers separated by two periods (..) and are inclusive. For example, a range of integers 0..4 includes the integers 0, 1, 2, 3, and 4.

Extents are specified by a pair of numbers in brackets ([]) separated by a colon (:) and are inclusive. Bit fields are often specified as extents. For example, bits [7:3] specifies bits 7, 6, 5, 4, and 3.

### **Register and Memory Figures**

Register figures have bit and field position numbering starting at the right (low order) and increasing to the left (high order).

Memory figures have addresses starting at the top and increasing toward the bottom.

## Signal Names

All signal names are printed in boldface type. Signal names that originate in an industry-standard specification, such as PCI or IDE, are printed in the case as found in the specification (usually uppercase). Active-high signals are indicated by the **\_h** suffix. Active-low signals have the **\_l** suffix, a pound sign “#” appended, or a “not” overscore bar. Signals with no suffix are considered high-asserted signals. For example, signals **data\_h[127:0]** and **cia\_int** are active-high signals. Signals **mem\_ack\_l**, **FRAME#**, and **RESET** are active-low signals.

## UNPREDICTABLE and UNDEFINED

Throughout this manual the terms UNPREDICTABLE and UNDEFINED are used. Their meanings are quite different and must be carefully distinguished.

In particular, only privileged software (that is, software running in kernel mode) can trigger UNDEFINED operations. Unprivileged software cannot trigger UNDEFINED operations. However, either privileged or unprivileged software can trigger UNPREDICTABLE results or occurrences.

UNPREDICTABLE results or occurrences do not disrupt the basic operation of the processor. The processor continues to execute instructions in its normal manner. In contrast, UNDEFINED operations can halt the processor or cause it to lose information.

The terms UNPREDICTABLE and UNDEFINED can be further described as follows:

- UNPREDICTABLE
  - Results or occurrences specified as UNPREDICTABLE might vary from moment to moment, implementation to implementation, and instruction to instruction within implementations. Software can never depend on results specified as UNPREDICTABLE.
  - An UNPREDICTABLE result might acquire an arbitrary value that is subject to a few constraints. Such a result might be an arbitrary function of the input operands or of any state information that is accessible to the process in its current access mode. UNPREDICTABLE results may be unchanged from their previous values.

Operations that produce UNPREDICTABLE results might also produce exceptions.

- An occurrence specified as UNPREDICTABLE may or may not happen based on an arbitrary choice function. The choice function is subject to the same constraints as are UNPREDICTABLE results and must not constitute a security hole.

Specifically, UNPREDICTABLE results must not depend upon, or be a function of, the contents of memory locations or registers that are inaccessible to the current process in the current access mode.

Also, operations that might produce UNPREDICTABLE results must not write or modify the contents of memory locations or registers to which the current process in the current access mode does not have access. They must also not halt or hang the system or any of its components.

For example, a security hole would exist if some UNPREDICTABLE result depended on the value of a register in another process, on the contents of processor temporary registers left behind by some previously running process, or on a sequence of actions of different processes.

- UNDEFINED

- Operations specified as UNDEFINED can vary from moment to moment, implementation to implementation, and instruction to instruction within implementations. The operation can vary in effect from nothing, to stopping system operation.
- UNDEFINED operations can halt the processor or cause it to lose information. However, UNDEFINED operations must not cause the processor to hang, that is, reach an unhalted state from which there is no transition to a normal state in which the machine executes instructions. Only privileged software (that is, software running in kernel mode) can trigger UNDEFINED operations.

---

# Introduction

This chapter provides an overview of the AlphaPC 164SX motherboard, including its components, features, and uses. The motherboard is a module for computing systems based on the 21174 core logic chip.

The AlphaPC 164SX provides a single-board hardware and software development platform for the design, integration, and analysis of supporting logic and subsystems. The board also provides a platform for PCI I/O device hardware and software development.

## 1.1 System Components and Features

The AlphaPC 164SX is implemented in industry-standard parts and uses an Alpha 21164PC microprocessor running at 400 or 533 MHz. Figure 1–1 shows the board's functional components.

# System Components and Features

Figure 1-1 AlphaPC 164SX Functional Block Diagram

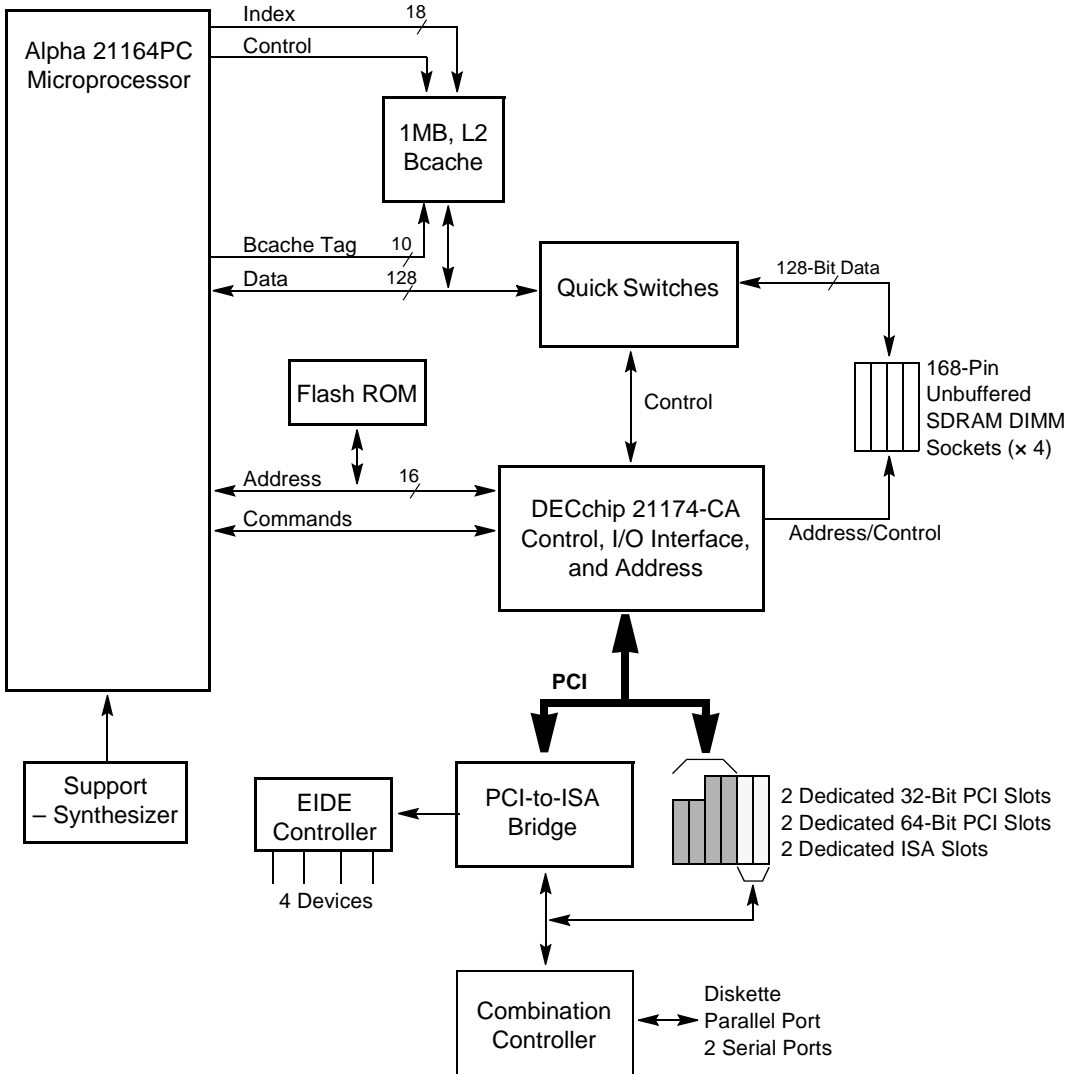

## 1.1.1 21174 Core Logic Chip

The Alpha 21164PC microprocessor is supported by the 21174 core logic chip, which provides an interface between three units—memory, the PCI bus, and the 21164PC (along with flash ROM). This core logic chip is the interface between the 21164PC microprocessor, main memory (addressing and control), and the PCI bus.

Quick switches provide the memory interface data path isolation.

The 21174 includes the majority of functions necessary to develop a high-performance PC or workstation, requiring minimum discrete logic on the module. It provides flexible and generic functions to allow its use in a wide range of systems.

## 1.1.2 Memory Subsystem

The synchronous dynamic random-access memory (SDRAM) is contained in two banks of dual inline memory modules (DIMMs). Single- or double-sided DIMMs may be used. Two DIMMs provide 32Mb to 256MB of memory, while four DIMMs provide up to 512MB. Table 1–1 lists the DIMM sizes tested and the corresponding main memory size for 128-bit arrays.

**Note:** Each DIMM can be 72 bits or 64 bits wide, with 100 MHz or faster speed.

**Table 1–1 AlphaPC 164SX SDRAM Memory Configurations** *(Sheet 1 of 2)*

Total Memory	Bank 0 <sup>1</sup>		Bank 1 <sup>1</sup>	
	J7	J8	J9	J10
32MB	2Mb × 72	2Mb × 72	—	—
64MB	2Mb × 72	2Mb × 72	2Mb × 72	2Mb × 72
	4Mb × 72	4Mb × 72	—	—
96MB	4Mb × 72	4Mb × 72	2Mb × 72	2Mb × 72
128MB	4Mb × 72	4Mb × 72	4Mb × 72	4Mb × 72
	8Mb × 72	8Mb × 72	—	—
160MB	8Mb × 72	8Mb × 72	2Mb × 72	2Mb × 72

# System Components and Features

**Table 1–1 AlphaPC 164SX SDRAM Memory Configurations** *(Sheet 2 of 2)*

Total Memory	Bank 0 <sup>1</sup>		Bank 1 <sup>1</sup>	
	J7	J8	J9	J10
192MB	8Mb × 72	8Mb × 72	4Mb × 72	4Mb × 72
256MB	8Mb × 72	8Mb × 72	8Mb × 72	8Mb × 72
	16Mb × 72	16Mb × 72	—	—
512MB	16Mb × 72	16Mb × 72	16Mb × 72	16Mb × 72

<sup>1</sup> 64-bit-wide DIMMs can also be used.

## 1.1.3 L2 Bcache Subsystem Overview

The AlphaPC 164SX board-level L2 backup cache (Bcache) is a 1MB, direct-mapped, synchronous, pipelined burst SDRAM with a 128-bit data path. The board is capable of handling an L2 cache size of 2MB. See Section 2.3 for more information about the Bcache.

## 1.1.4 PCI Interface Overview

The AlphaPC 164SX PCI interface, with a 33-MHz data transfer rate, is the main I/O bus for the majority of functions (SCSI interface, graphics accelerator, and so on). PCI-EIDE support is provided by an onboard controller chip (Cypress CY82C693U-NC), which also provides a PCI-to-ISA bridge, a mouse and keyboard controller, and a time-of-year (TOY) clock.

The PCI bus has four dedicated PCI expansion slots (two 64-bit and two 32-bit).

## 1.1.5 ISA Interface Overview

The ISA bus provides the following system support functions:

- Two expansion slots.
- An SMC FDC37C669 combination controller chip that provides:
  - A diskette controller
  - Two universal asynchronous receiver-transmitters (UARTs) with full modem control
  - A bidirectional parallel port

## 1.1.6 Miscellaneous Logic

The AlphaPC 164SX contains the following miscellaneous components:

- Operating system support — through a 1MB flash ROM that contains supporting firmware.
- Synthesizer for clocks:
  - A clock synthesizer (MC12439) provides a programmable 400- and 533-MHz clock source to the 21164PC microprocessor. The microprocessor supplies a clock to the system PLL/clock buffer for the 21174.
  - The 21174 core logic chip provides the SDRAM and PCI clocks.
  - A 14.318-MHz crystal and frequency generator provide a clock source for the combination controller (FDC37C669) and the PCI-to-ISA bridge (CY82C693U-NC). The controller's onchip generator then provides other clocks as needed.
  - A 32-kHz crystal provides the TOY clock source.
- Flash ROM:
  - Fail-safe booter
  - Boot code
  - BIOS: Windows NT or Alpha SRM console
- Altera EPM7064LC44-7 for DMA boundary issue.

## 1.2 Software Support

The support elements described in this section are either included with the AlphaPC 164SX or are available separately.

### 1.2.1 AlphaBIOS Windows NT Firmware

The AlphaPC 164SX motherboard ships with AlphaBIOS firmware and online documentation that describes how to configure the firmware for Windows NT. This firmware initializes the system and enables you to install and boot the Windows NT operating system. The AlphaBIOS firmware resides in the flash ROM on the 21A05-A0 variation of the AlphaPC 164SX motherboard. Binary images of the AlphaBIOS firmware are included in the motherboard Software Developer's Kit (SDK), along with a license describing the terms for use and distribution.

## Hardware Design Support

### 1.2.2 Alpha SRM Console Firmware

The Alpha SRM Console firmware is required to install and boot DIGITAL UNIX on the AlphaPC 164SX. This Alpha firmware comes factory installed in the 21A05-A1 variation of the AlphaPC 164SX. When installed, this firmware occupies the flash blocks reserved for the primary firmware. Binary images of the Alpha SRM Console firmware are included in the SDK and Firmware Update compact disk, along with a license describing the terms for use and distribution.

### 1.2.3 Motherboard Software Developer's Kit (SDK)

The SDK and Firmware Update is designed to provide an environment for developing software for Alpha motherboard products. It is also specially suited for low-level software development and hardware debug for other Alpha microprocessor-based designs.

The following list includes some of the components of the SDK:

- The Alpha Motherboard Debug Monitor firmware with source code
- Power-up initialization SROM and SROM Mini-Debugger with source code
- Sample PALcode sources modeled after DIGITAL UNIX with source code
- Fail-safe booter with source code
- Various additional tools with source code

The following development platforms are supported by the SDK:

- DIGITAL UNIX with the C Developer's Extensions
- Windows NT (Alpha) with the Microsoft Visual C++ Development System for Alpha
- Windows NT (Intel) with the Microsoft Visual C++ Development System and Tools provide limited support. This environment is currently useful for SROM and PALcode development only.

## 1.3 Hardware Design Support

The full design database, including schematics and source files, is supplied. User documentation is also included. The database allows designers with no previous Alpha architecture experience to successfully develop a working Alpha system with minimal assistance.

---

## System Configuration and Connectors

This chapter describes the AlphaPC 164SX configuration, board connectors and functions, and switch functions. It also identifies switch and connector locations.

The AlphaPC 164SX uses switches to implement configuration parameters such as system speed and boot parameters. These switches must be configured for the user's environment. Onboard connectors are provided for the I/O interfaces, DIMMs, and serial and parallel peripheral ports.

Figure 2-1 shows the board outlines and identifies the location of switches, connectors, and major components. Table 2-1 lists and defines these items.

**Figure 2-1 AlphaPC 164SX Switch/Connector/Component Location**

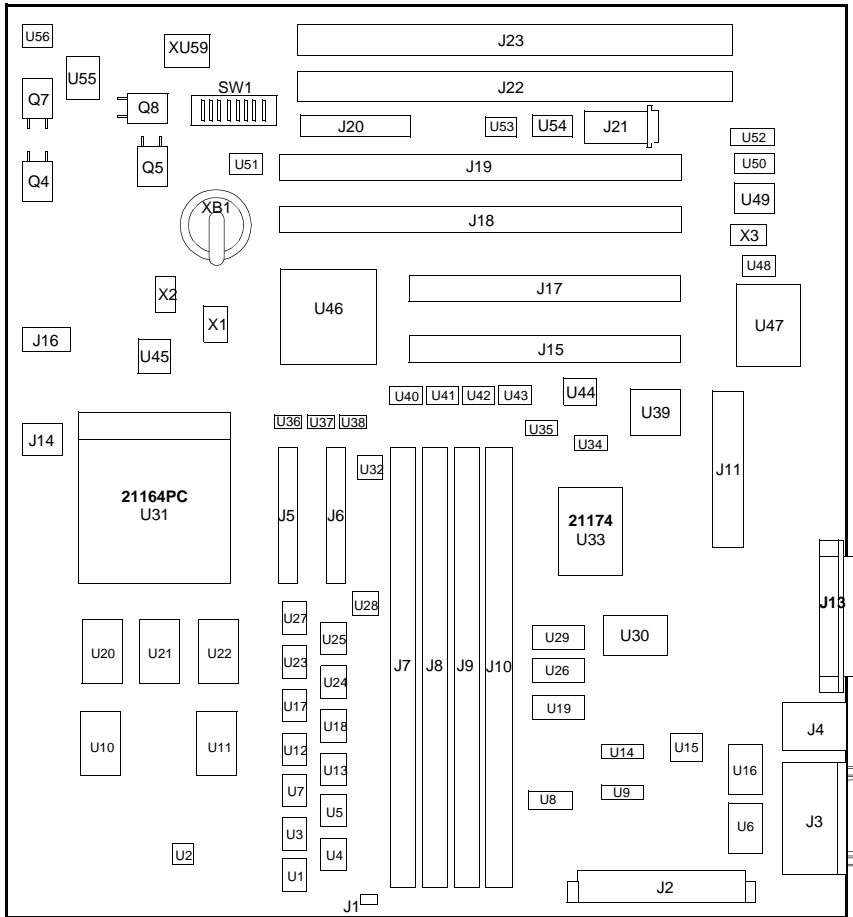

**Table 2–1 AlphaPC 164SX Switch/Connector/Component List**

<b>Item No.</b>	<b>Description</b>	<b>Item No.</b>	<b>Description</b>
XB1	RTC battery (CR2032)	J20	LEDs/speaker/buttons connectors
J1	Soft power connector	J21	SRAM test port connector
J2	Input power (+3 V, +5 V, -5 V, +12 V, -12 V)	J22	ISA slot 1
J3	COM1/COM2 (DB9) connectors	J23	ISA slot 0
J4	Keyboard/mouse connectors	SW1	Configuration switchpack
J5	EIDE drive 2/3 connector	U48	System clock PLL (CY2081)
J6	EIDE drive 0/1 connector	U10, U11, U20, U22	L2 cache data SRAMs
J7	SDRAM DIMM 0 [0:63] connector	U21	L2 cache tag SRAM
J8	SDRAM DIMM 1 [64:128] connector	U33	21174 core logic chip
J9	SDRAM DIMM 2 [0:63] connector	U19, U26, U29	Memory address/control buffers
J10	SDRAM DIMM 3 [64:128] connector	U1, U3, U4, U5, U7, U12, U13, U17, U18, U23, U24, U25, U27	Data switches
J11	Diskette (floppy) drive connector	U40 to U43	Interrupt shift registers
J13	Parallel I/O connector	U30	Flash ROM (1MB)
J14	Microprocessor fan/fan sense connector	U46	PCI-ISA Bridge (CY82C693U-NC)
J15	PCI slot 3 (32-bit)	U36 to U38	IDE buffers
J16	Fan power, enclosure (+12 V)	U47	Combination controller (FDC37C669)
J17	PCI slot 2 (32-bit)	U2, U28, U32	Reg-reg cache isolate logic
J18	PCI slot 1 (64-bit)	U31	Microprocessor, socketed (Alpha 21164PC)
J19	PCI slot 0 (64-bit)	U45	Microprocessor clock synthesizer (MC12439)

# AlphaPC 164SX Configuration Switches

## 2.1 AlphaPC 164SX Configuration Switches

The AlphaPC 164SX motherboard has a switchpack located at SW1, as shown previously in Figure 2–1. The switches set the hardware configuration and boot options. Figure 2–2 shows the switch functions.

**Figure 2–2 AlphaPC 164SX Configuration Switches**

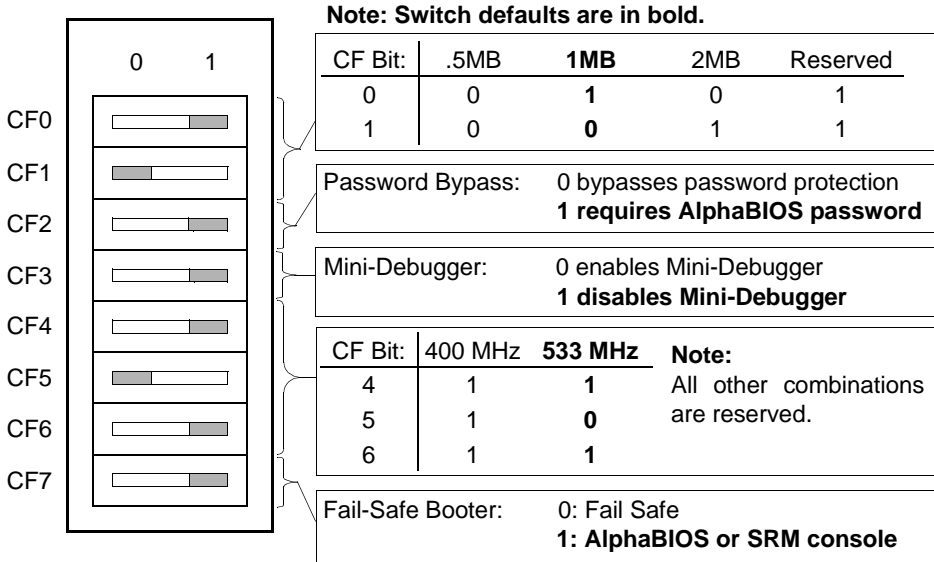

## 2.2 CPU Speed Selection (CF[6:4])

The clock synthesizer at U45 makes it possible to change the frequency of the microprocessor’s clock output. The switch configuration is set in SW1, CF[6:4]. These three switches set the speed at power-up as listed in Figure 2–2. The microprocessor frequency divided by the ratio determines the system clock frequency.

### 2.3 Bcache Size Switches (CF0 and CF1)

The Bcache size switches are located at SW1 (CF0 and CF1), as shown in Figure 2–2. The AlphaPC 164SX is configured with 1MB of Bcache during production; the other combinations shown in Figure 2–2 (.5MB and 2MB) are for other implementations.

**Note:** The standard motherboard (21A05-A0 for Windows NT and 21A05-A1 for DIGITAL UNIX) is manufactured with 64K × 32 data SSRAMs. An OEM, however, can create an L2 cache in either a 2MB variation, using 128K × 32 data SSRAMs, or a .5MB variation, using 32K × 32 data SSRAMs.

### 2.4 Password Bypass (CF2)

AlphaBIOS provides password protection. However, password bypass is provided for system setup or startup when the AlphaBIOS password is unavailable.

Password bypass is disabled by default, with switch CF2 of SW1 in the on position (see Figure 2–2). When this function is enabled, it disables the AlphaBIOS password verification and enables the user to set up or start up their system without the AlphaBIOS password. Password bypass also clears the password.

To disable this function and require a password, slide CF2 to the on position.

### 2.5 Fail-Safe Booter (CF7)

The fail-safe booter provides an emergency recovery mechanism when the primary firmware image contained in flash memory has been corrupted. When flash memory has been corrupted, and no image can be loaded safely from the flash, you can run the fail-safe booter and boot another image from a diskette that is capable of reprogramming the flash.

For more information about the fail-safe booter, refer to the *AlphaPC 164SX Motherboard Windows NT User's Manual*.

## Mini-Debugger (CF3)

### 2.6 Mini-Debugger (CF3)

The Alpha SROM Mini-Debugger is stored in the flash ROM and is enabled/disabled by switch CF3. The default position for this switch is on (see Figure 2–2). When this switch is off, it causes the SROM initialization to trap to the Mini-Debugger after all initialization is complete, but before starting the execution of the system flash ROM code.

### 2.7 AlphaPC 164SX Connector Pinouts

This section lists the pinouts of all AlphaPC 164SX connectors. See Figure 2–1 for connector locations.

#### 2.7.1 PCI Bus Connector Pinouts

Table 2–2 shows the PCI bus connector pinouts.

**Table 2–2 PCI Bus Connector Pinouts**

*(Sheet 1 of 2)*

Pin	Signal	Pin	Signal	Pin	Signal	Pin	Signal
<b>32-Bit and 64-Bit PCI Connectors (J15, J17, J18, J19)</b>							
A1	TRST#	A2	+12V	A3	TMS	A4	TDI
A5	Vdd	A6	INTA	A7	INTC	A8	Vdd
A9	—	A10	Vdd	A11	—	A12	Gnd
A13	Gnd	A14	—	A15	RST#	A16	Vdd
A17	GNT#	A18	Gnd	A19	—	A20	AD[30]
A21	+3V	A22	AD[28]	A23	AD[26]	A24	Gnd
A25	AD[24]	A26	IDSEL	A27	+3V	A28	AD[22]
A29	AD[20]	A30	Gnd	A31	AD[18]	A32	AD[16]
A33	+3V	A34	FRAME#	A35	Gnd	A36	TRDY#
A37	STOP#	A38	STOP#	A39	+3V	A40	SDONE
A41	SBO#	A42	Gnd	A43	PAR	A44	AD[15]
A45	+3V	A46	AD[13]	A47	AD[11]	A48	Gnd
A49	AD[09]	A50	Not used	A51	Not used	A52	C/BE#[0]
A53	+3V	A54	AD[06]	A55	AD[04]	A56	Gnd
A57	AD[02]	A58	AD[00]	A59	Vdd	A60	REQ64#
A61	Vdd	A62	Vdd	B1	-12V	B2	TCK
B3	Gnd	B4	TDO	B5	Vdd	B6	Vdd
B7	INTB	B8	INTD	B9	PRSNT1#	B10	—
B11	PRSNT2#	B12	Gnd	B13	Gnd	B14	—

# AlphaPC 164SX Connector Pinouts

**Table 2–2 PCI Bus Connector Pinouts**

*(Sheet 2 of 2)*

Pin	Signal	Pin	Signal	Pin	Signal	Pin	Signal
B15	Gnd	B16	CLK	B17	Gnd	B18	REQ#
B19	Vdd	B20	AD[31]	B21	AD[29]	B22	Gnd
B23	AD[27]	B24	AD[25]	B25	+3V	B26	C/BE#[3]
B27	AD[23]	B28	Gnd	B29	AD[21]	B30	AD[19]
B31	+3V	B32	AD[17]	B33	C/BE#[2]	B34	Gnd
B35	IRDY#	B36	+3V	B37	DEVSEL#	B38	Gnd
B39	LOCK#	B40	PERR#	B41	+3V	B42	SERR#
B43	+3V	B44	C/BE#[1]	B45	AD[14]	B46	Gnd
B47	AD[12]	B48	AD[10]	B49	Gnd	B50	Not used
B51	Not used	B52	AD[08]	B53	AD[07]	B54	+3V
B55	AD[05]	B56	AD[03]	B57	Gnd	B58	AD[01]
B59	Vdd	B60	ACK64#	B61	Vdd	B62	Vdd
<b>64-Bit PCI Connectors Only (J18, J19)</b>							
A63	Gnd	A64	C/BE#[7]	A65	C/BE#[5]	A66	Vdd
A67	PAR64	A68	D[62]	A69	Gnd	A70	D[60]
A71	D[58]	A72	Gnd	A73	D[56]	A74	D[54]
A75	Vdd	A76	D[52]	A77	D[50]	A78	Gnd
A79	D[48]	A80	D[46]	A81	Gnd	A82	D[44]
A83	D[42]	A84	Vdd	A85	D[40]	A86	D[38]
A87	Gnd	A88	D[36]	A89	D[34]	A90	Gnd
A91	D[32]	A92	—	A93	Gnd	A94	—
B63	—	B64	Gnd	B65	C/BE#[6]	B66	C/BE#[4]
B67	Gnd	B68	D[63]	B69	D[61]	B70	Vdd
B71	D[59]	B72	D[57]	B73	Gnd	B74	D[55]
B75	D[53]	B76	Gnd	B77	D[51]	B78	D[49]
B79	Vdd	B80	D[47]	B81	D[45]	B82	Gnd
B83	D[43]	B84	D[41]	B85	Gnd	B86	D[39]
B87	D[37]	B88	Vdd	B89	D[35]	B90	D[33]
B91	Gnd	B92	—	B93	—	B94	Gnd

# AlphaPC 164SX Connector Pinouts

## 2.7.2 ISA Expansion Bus Connector Pinouts

Table 2–3 shows the ISA expansion bus connector pinouts.

**Table 2–3 ISA Expansion Bus Connector Pinouts (J22, J23)**

Pin	Signal	Pin	Signal	Pin	Signal	Pin	Signal
1	Gnd	2	IOCHCK#	3	RSTDRV	4	SD7
5	Vdd	6	SD6	7	IRQ9	8	SD5
9	-5V	10	SD4	11	DRQ2	12	SD3
13	-12V	14	SD2	15	ZEROWS#	16	SD1
17	+12V	18	SD0	19	Gnd	20	IOCHRDY
21	SMEMW#	22	AEN	23	SMEMR#	24	SA19
25	IOW#	26	SA18	27	IOR#	28	SA17
29	DACK3#	30	SA16	31	DRQ3	32	SA15
33	DACK1#	34	SA14	35	DRQ1	36	SA13
37	REFRESH#	38	SA12	39	SYSCLK	40	SA11
41	IRQ7	42	SA10	43	IRQ6	44	SA9
45	IRQ5	46	SA8	47	IRQ4	48	SA7
49	IRQ3	50	SA6	51	DACK2#	52	SA5
53	TC	54	SA4	55	BALE	56	SA3
57	Vdd	58	SA2	59	OSC	60	SA1
61	Gnd	62	SA0	63	MEMCS16#	64	SBHE#
65	IOCS16#	66	LA23	67	IRQ10	68	LA22
69	IRQ11	70	LA21	71	IRQ12	72	LA20
73	IRQ15	74	LA19	75	IRQ14	76	LA18
77	DACK0#	78	LA17	79	DRQ0	80	MEMR#
81	DACK5#	82	MEMW#	83	DRQ5	84	SD8
85	DACK6#	86	SD9	87	DRQ6	88	SD10
89	DACK7#	90	SD11	91	DRQ7	92	SD12
93	Vdd	94	SD13	95	MASTER#	96	SD14
97	Gnd	98	SD15	—	—	—	—

### 2.7.3 SDRAM DIMM Connector Pinouts

Table 2–4 shows the SDRAM DIMM connector pinouts.

**Table 2–4 SDRAM DIMM Connector Pinouts (J7 through J10)<sup>1</sup>**

(Sheet 1 of 2)

Pin	Signal	Pin	Signal	Pin	Signal	Pin	Signal
1	Gnd	2	DQ0	3	DQ1	4	DQ2
5	DQ3	6	+3V	7	DQ4	8	DQ5
9	DQ6	10	DQ7	11	DQ8	12	Gnd
13	DQ9	14	DQ10	15	DQ11	16	DQ12
17	DQ13	18	+3V	19	DQ14	20	DQ15
21	CB0	22	CB1	23	Gnd	24	NC
25	NC	26	+3V	27	$\overline{\text{WE}}$	28	DQMB0
29	DQMB1	30	$\overline{\text{S0}}$	31	NC	32	Gnd
33	A0	34	A2	35	A4	36	A6
37	A8	38	A10	39	A12	40	+3V
41	+3V	42	CK0	43	Gnd	44	NC
45	$\overline{\text{S2}}$	46	DQMB2	47	DQMB3	48	NC
49	+3V	50	NC	51	NC	52	CB2
53	CB3	54	Gnd	55	DQ16	56	DQ17
57	DQ18	58	DQ19	59	+3V	60	DQ20
61	NC	62	NC	63	CKE1	64	Gnd
65	DQ21	66	DQ22	67	DQ23	68	Gnd
69	DQ24	70	DQ25	71	DQ26	72	DQ27
73	+3V	74	DQ28	75	DQ29	76	DQ30
77	DQ31	78	Gnd	79	CK2	80	NC
81	NC	82	SDA	83	SCL	84	+3V
85	Gnd	86	DQ32	87	DQ33	88	DQ34
89	DQ35	90	+3V	91	DQ36	92	DQ37
93	DQ38	94	DQ39	95	DQ40	96	Gnd
97	DQ41	98	DQ42	99	DQ43	100	DQ44
101	DQ45	102	+3V	103	DQ46	104	DQ47
105	CB4	106	CB5	107	Gnd	108	NC
109	NC	110	+3V	111	$\overline{\text{CAS}}$	112	DQMB4
113	DQMB5	114	S1	115	$\overline{\text{RAS}}$	116	Gnd
117	A1	118	A3	119	A5	120	A7
121	A9	122	BA0	123	A13	124	+3V

## AlphaPC 164SX Connector Pinouts

**Table 2–4 SDRAM DIMM Connector Pinouts (J7 through J10)<sup>1</sup>**

(Sheet 2 of 2)

Pin	Signal	Pin	Signal	Pin	Signal	Pin	Signal
125	<b>CK1</b>	126	<b>BA1<sup>2</sup></b>	127	<b>Gnd</b>	128	<b>CKE0</b>
129	<b>S<sub>3</sub></b>	130	<b>DQMB6</b>	131	<b>DQMB7</b>	132	<b>PD<sup>3</sup></b>
133	<b>+3V</b>	134	<b>NC</b>	135	<b>NC</b>	136	<b>CB6</b>
137	<b>CB7</b>	138	<b>Gnd</b>	139	<b>DQ48</b>	140	<b>DQ49</b>
141	<b>DQ50</b>	142	<b>DQ51</b>	143	<b>+3V</b>	144	<b>DQ52</b>
145	<b>NC</b>	146	<b>NC</b>	147	<b>PD</b>	148	<b>Gnd</b>
149	<b>DQ53</b>	150	<b>DQ54</b>	151	<b>DQ55</b>	152	<b>Gnd</b>
153	<b>DQ56</b>	154	<b>DQ57</b>	155	<b>DQ58</b>	156	<b>DQ59</b>
157	<b>+3V</b>	158	<b>DQ60</b>	159	<b>DQ61</b>	160	<b>DQ62</b>
161	<b>DQ63</b>	162	<b>Gnd</b>	163	<b>CK3</b>	164	<b>NC</b>
165	<b>SA0</b>	166	<b>SA1</b>	167	<b>SA2</b>	168	<b>+3V</b>

<sup>1</sup> Pins 1 through 84 are on the front side and pins 85 through 168 are on the back side.

<sup>2</sup> The AlphaPC 164SX uses **BA1** as both **BA1** and **ADDR12**. Therefore, four-bank DIMMs using **ADDR[11:0]** are the maximum size. (Two-bank DIMMs can use **ADDR[12:0]**.)

<sup>3</sup> Pull-down.

### 2.7.4 EIDE Drive Bus Connector Pinouts

Table 2–5 shows the EIDE drive bus connector pinouts.

**Table 2–5 EIDE Drive Bus Connector Pinouts (J5, J6)**

Pin	Signal	Pin	Signal	Pin	Signal	Pin	Signal
1	<b>RESET</b>	2	<b>Gnd</b>	3	<b>IDE_D7</b>	4	<b>IDE_D8</b>
5	<b>IDE_D6</b>	6	<b>IDE_D9</b>	7	<b>IDE_D5</b>	8	<b>IDE_D10</b>
9	<b>IDE_D4</b>	10	<b>IDE_D11</b>	11	<b>IDE_D3</b>	12	<b>IDE_D12</b>
13	<b>IDE_D2</b>	14	<b>IDE_D13</b>	15	<b>IDE_D1</b>	16	<b>IDE_D14</b>
17	<b>IDE_D0</b>	18	<b>IDE_D15</b>	19	<b>Gnd</b>	20	<b>NC (key pin)</b>
21	<b>MARQ</b>	22	<b>Gnd</b>	23	<b><math>\overline{IOW}</math></b>	24	<b>Gnd</b>
25	<b><math>\overline{IOR}</math></b>	26	<b>Gnd</b>	27	<b>CHRDY</b>	28	<b>BALE</b>
29	<b>MACK</b>	30	<b>Gnd</b>	31	<b>IRQ</b>	32	<b><math>\overline{IOCS16}</math></b>
33	<b>ADDR1</b>	34	<b>NC</b>	35	<b>ADDR0</b>	36	<b>ADDR2</b>
37	<b><math>\overline{CS0}</math></b>	38	<b><math>\overline{CS1}</math></b>	39	<b><math>\overline{ACT}</math></b>	40	<b>Gnd</b>

## 2.7.5 Diskette (Floppy) Drive Bus Connector Pinouts

Table 2–6 shows the diskette (floppy) drive bus connector pinouts.

**Table 2–6 Diskette (Floppy) Drive Bus Connector Pinouts (J11)**

Pin	Signal	Pin	Signal	Pin	Signal	Pin	Signal
1	Gnd	2	DEN0	3	Gnd	4	NC
5	Gnd	6	DEN1	7	Gnd	8	INDEX
9	Gnd	10	MTR0	11	Gnd	12	DR1
13	Gnd	14	DR0	15	Gnd	16	MTR1
17	Gnd	18	DIR	19	Gnd	20	STEP
21	Gnd	22	WDATA	23	Gnd	24	WGATE
25	Gnd	26	TRK0	27	Gnd	28	WRTPRT
29	ID0	30	RDATA	31	Gnd	32	HDSEL
33	ID1	34	DSKCHG	—	—	—	—

## 2.7.6 Parallel Bus Connector Pinouts

Table 2–7 shows the parallel bus connector pinouts.

**Table 2–7 Parallel Bus Connector Pinouts (J13)**

Pin	Signal	Pin	Signal	Pin	Signal	Pin	Signal
1	STB	2	PD0	3	PD1	4	PD2
5	PD3	6	PD4	7	PD5	8	PD6
9	PD7	10	ACK	11	BUSY	12	PE
13	SLCT	14	AFD	15	ERR	16	INIT
17	SLIN	18	Gnd	19	Gnd	20	Gnd
21	Gnd	22	Gnd	23	Gnd	24	Gnd
25	Gnd	—	—	—	—	—	—

# AlphaPC 164SX Connector Pinouts

## 2.7.7 COM1/COM2 Serial Line Connector Pinouts

Table 2–8 shows the COM1/COM2 serial line connector pinouts.

**Table 2–8 COM1/COM2 Serial Line Connector Pinouts (J3)**

<b>COM1 Pin (Top)</b>	<b>COM1 Signal</b>	<b>COM2 Pin (Bottom)</b>	<b>COM2 Signal</b>
1	<b>DCD1</b>	1	<b>DCD2</b>
2	<b>RxD1</b>	2	<b>RxD2</b>
3	<b>TxD1</b>	3	<b>TxD2</b>
4	<b>DTR1</b>	4	<b>DTR2</b>
5	<b>SG1</b>	5	<b>SG2</b>
6	<b>DSR1</b>	6	<b>DSR2</b>
7	<b>RTS1</b>	7	<b>RTS2</b>
8	<b>CTS1</b>	8	<b>CTS2</b>
9	<b>RI1</b>	9	<b>RI2</b>

## 2.7.8 Keyboard/Mouse Connector Pinouts

Table 2–9 shows the keyboard/mouse connector pinouts.

**Table 2–9 Keyboard/Mouse Connector Pinouts (J4)**

<b>Keyboard Pin (Top)</b>	<b>Keyboard Signal</b>	<b>Mouse Pin (Bottom)</b>	<b>Mouse Signal</b>
1	<b>KBDATA</b>	1	<b>MSDATA</b>
2	<b>NC</b>	2	<b>NC</b>
3	<b>Gnd</b>	3	<b>Gnd</b>
4	<b>Vdd</b>	4	<b>Vdd</b>
5	<b>KBCLK</b>	5	<b>MSCLK</b>
6	<b>NC</b>	6	<b>NC</b>

## 2.7.9 SROM Test Data Input Connector Pinouts

Table 2–10 shows the SROM test data input connector pinouts.

**Table 2–10 SROM Test Data Input Connector Pinouts (J21)**

Pin	Signal	Description
1	NC	—
2	SROM_CLK_L	Clock out
3	Gnd	—
4	NC	—
5	TEST_SROM_D_L	SROM serial data in
6	NC	—

## 2.7.10 Input Power Connector Pinouts

Table 2–11 shows the input power connector pinouts.

**Table 2–11 Input Power Connector Pinouts (J2)<sup>1</sup>**

Pin	Voltage	Pin	Voltage	Pin	Voltage	Pin	Voltage
1	+3.3 V dc	2	+3.3 V dc	3	Gnd	4	+5 V dc
5	Gnd	6	+5 V dc	7	Gnd	8	P_DCOK
9	5 V SB	10	+12 V dc	11	+3.3 V dc	12	–12 V dc
13	Gnd	14	PS_ON	15	Gnd	16	Gnd
17	Gnd	18	–5 V dc	19	+5 V dc	20	+5 V dc

<sup>1</sup> This pinout is ATX-compliant.

## 2.7.11 Enclosure Fan Power Connector Pinouts

Table 2–12 shows the enclosure fan power connector pinouts.

**Table 2–12 Enclosure Fan (+12 V dc) Power Connector Pinouts (J16)**

Pin	Voltage
1	Gnd
2	+12 V dc
3	Gnd

# AlphaPC 164SX Connector Pinouts

## 2.7.12 Microprocessor Fan Power Connector Pinouts

Table 2–13 shows the microprocessor fan power connector pinouts.

**Table 2–13 Microprocessor Fan Power Connector Pinouts (J14)**

Pin	Signal	Description
1	+12 V dc	—
2	FAN_CONN_L	Fan connected
3	Gnd	—

## 2.7.13 Soft Power Connector Pinouts

Table 2–14 shows the soft power connector pinouts.

**Table 2–14 Soft Power Connector Pinouts (J1)**

Pin	Signal	Description
1	Input	System power on/off
2	Gnd	—

## 2.7.14 Multipurpose Connector Pinouts

J20 is a multipurpose connector that provides pins for the following functions:

- System speaker
- LEDs for power and the EIDE drive
- Buttons for reset and halt

Table 2–15 shows the multipurpose connector pinouts, and Figure 2–3 shows the connector layout.

**Table 2–15 Multipurpose Connector Pinouts (J20)**

*(Sheet 1 of 2)*

Pin	Signal	Description
1	Gnd	—
2	HALT_BUTTON <sup>1</sup>	Halt system
3	Gnd	—
4	RESET_BUTTON	Reset system
5	HD_PU	Hard drive power-up
6	HD_LED	Pull-up to Vdd

**Table 2–15 Multipurpose Connector Pinouts (J20)**

*(Sheet 2 of 2)*

Pin	Signal	Description
7	—	No connection
8	<b>POWER_LED_L</b>	Pull-up to <b>Vdd</b>
10, 12, 14, 16	<b>Gnd</b>	—
9	<b>SPKR</b>	Speaker output
15	<b>Vdd</b>	—
11, 13	—	No connection

<sup>1</sup> The halt button is not used with the Windows NT operating system.

**Figure 2–3 Multipurpose Connector Pinouts**

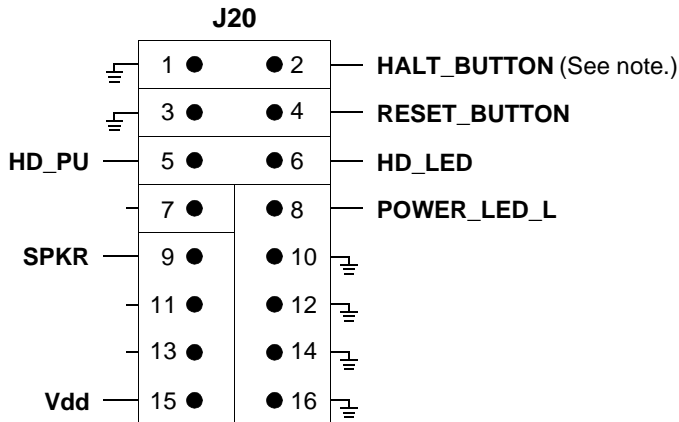

**Note:** The halt button is not used with Windows NT.



---

## Power and Environmental Requirements

This chapter describes the AlphaPC 164SX power and environmental requirements, and physical board parameters.

### 3.1 Power Requirements

The AlphaPC 164SX derives its main dc power from a user-supplied power supply. The board has a total power dissipation of 90 W, excluding any plug-in PCI and ISA devices. An onboard +5-V to +2.5-V dc-to-dc converter is designed to handle 24 A of current. Table 3–1 lists the power requirement for each dc supply voltage.

The power supply must supply a **dcok** signal to the system reset logic. Refer to Section 4.6 for additional information.

**Table 3–1 Power Supply DC Current Requirements**

Voltage/Tolerance	Current <sup>1</sup>
+3.3 V dc, ±5%	5.0 A
+5 V dc, ±5%	12.0 A
–5 V dc, ±5%	0.0 A
+12 V dc, ±5%	1.0 A
–12 V dc, ±5%	100.0 mA

<sup>1</sup> Values indicated are for an AlphaPC 164SX motherboard with an Alpha 21164PC microprocessor operating at 533 MHz, with 128MB SDRAM, excluding adapter cards and disk drives.

**Caution:** **Fan sensor required.** The 21164PC microprocessor cooling fan *must* drive an RPM indicator signal. If the airflow stops, the sensor on the motherboard detects that the RPM has stopped, and resets the system.

# Environmental Requirements

## 3.2 Environmental Requirements

The 21164PC microprocessor is cooled by a small fan blowing directly into the chip's heat sink. The AlphaPC 164SX motherboard is designed to run efficiently by using only this fan. Additional fans may be necessary depending upon cabinetry and the requirements of plug-in cards.

The AlphaPC 164SX motherboard is specified to run within the environment listed in Table 3–2.

**Table 3–2 AlphaPC 164SX Motherboard Environmental Requirements**

Parameter	Specification
Operating temperature	10°C to 40°C (50°F to 104°F)
Storage temperature	–55°C to 125°C (–67°F to 257°F)
Relative humidity	10% to 90% with maximum wet bulb temperature 28°C (82°F) and minimum dew point 2°C (36°F)
Rate of (dry bulb) temperature change	11°C/hour $\pm$ 2°C/hour (20°F/hour $\pm$ 4°F/hour)

## 3.3 Board Dimensions

The AlphaPC 164SX is an ATX-size printed-wiring board (PWB) with the following dimensions:

- Length: 30.48 cm (12.0 in  $\pm$ 0.0005 in)
- Width: 24.38 cm (9.6 in  $\pm$ 0.0005 in)
- Height: 6.00 cm (2.4 in)

The board can be used in certain desktop and desktside systems that have adequate clearance for the 21164PC heat sink and its cooling fan. All ISA and PCI expansion slots are usable in standard desktop or desktside enclosures.



# Board Dimensions

## 3.3.2 ATX I/O Shield Requirements

Figure 3-2 shows the ATX I/O shield dimensions for the AlphaPC 164SX.

Figure 3-2 ATX I/O Shield Dimensions

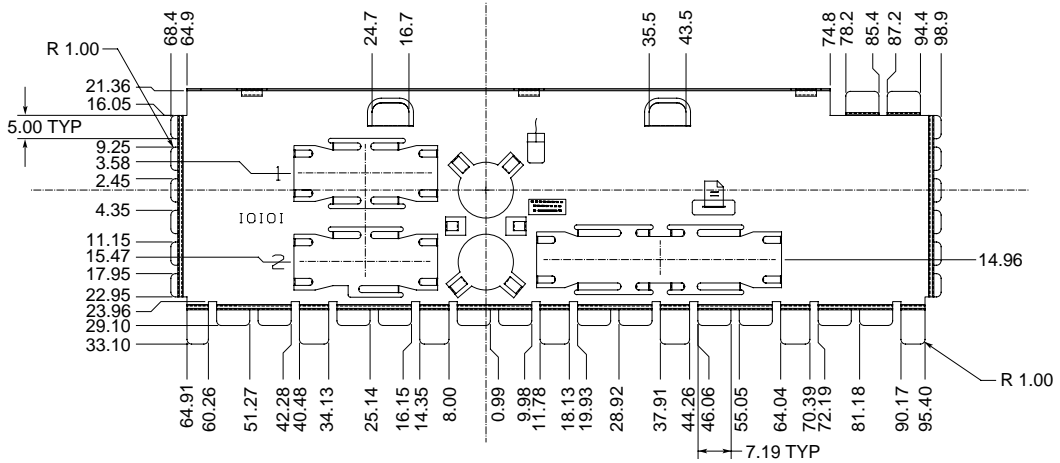

FM-05986.A14

---

## Functional Description

This chapter describes the functional operation of the AlphaPC 164SX. The description introduces the 21174 core logic chip and describes its implementation with the 21164PC microprocessor, its supporting memory, and I/O devices. Figure 1–1 shows the AlphaPC 164SX major functional components.

Bus timing and protocol information found in other data sheets and reference documentation is not duplicated. See Appendix A for a list of supporting documents and order numbers.

**Note:** For detailed descriptions of bus transactions, chip logic, and operation, refer to the *Alpha 21164PC Microprocessor Hardware Reference Manual* and the *21174 Core Logic Chip Technical Reference Manual*. For details of the PCI interface, refer to the *PCI System Design Guide*.

# AlphaPC 164SX Bcache Interface

## 4.1 AlphaPC 164SX Bcache Interface

The 21164PC microprocessor controls the board-level L2 backup cache (Bcache) array (see Figure 4–1). The data bus (**data\_h[127:0]**) signals are shared with the system interface.

Figure 4–1 AlphaPC 164SX L2 Bcache Array

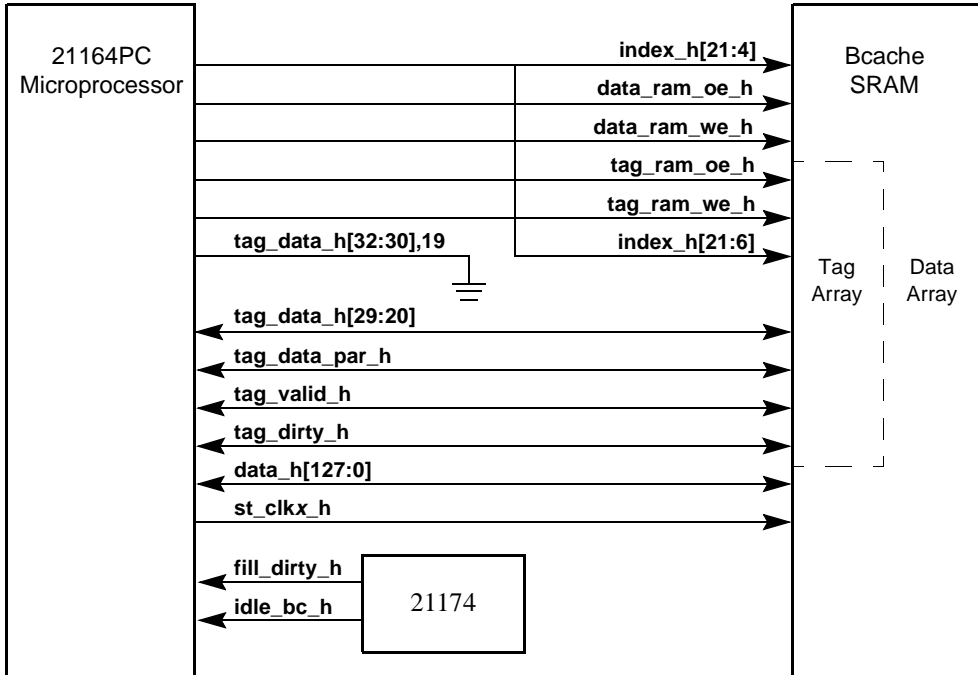

The Bcache is a 1MB, direct-mapped, pipelined, synchronous burst SRAM (SSRAM) with a 128-bit data path. It is populated with a quantity of four 133-MHz, 64K × 32 SSRAMs for data store, and one 133-MHz, 32K × 32 SSRAM for tag store. The Bcache supports 64-byte transfers to and from memory.

## 4.2 21174 Core Logic Chip

The 21174 core logic chip provides a cost-competitive solution for designers using the 21164PC microprocessor to develop uniprocessor systems. The chip provides a 128-bit memory interface and a PCI I/O interface, and includes the 21174-CA chip packaged in a 474-pin plastic ball grid array (PBGA).

Figure 4–2 shows the AlphaPC 164SX implementation of the 21174 core logic chip.

**Figure 4–2 Main Memory Interface**

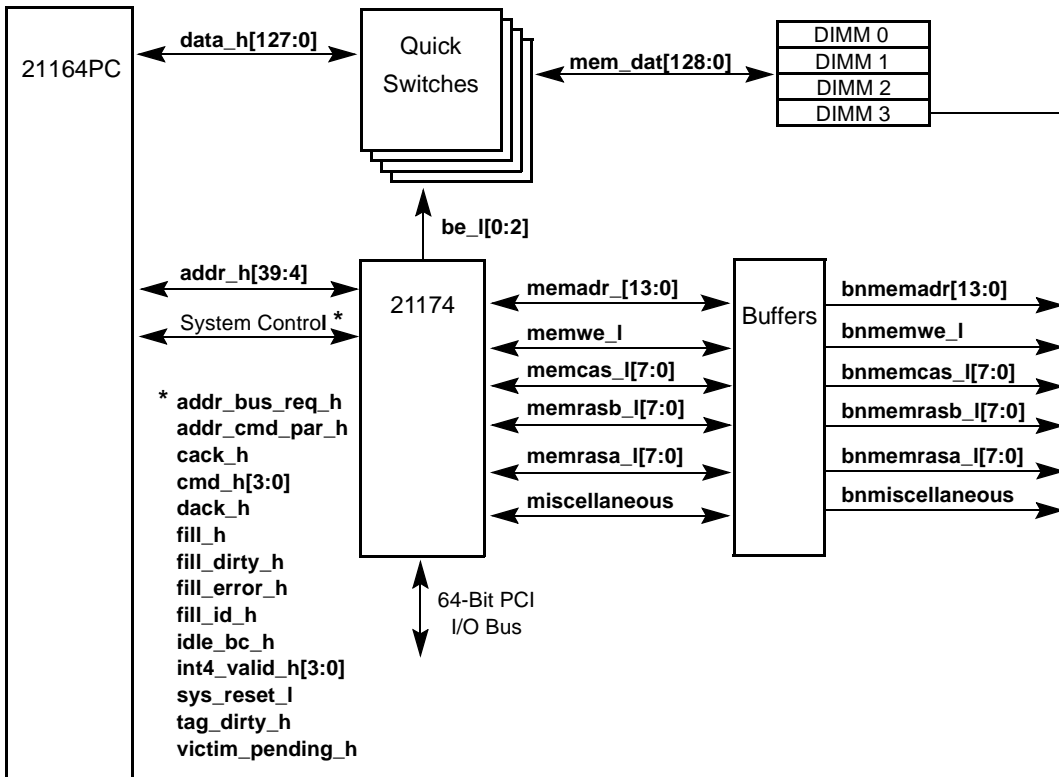

### 4.2.1 21174 Chip Overview

The 21174 application-specific integrated circuit (ASIC) accepts addresses and commands from the 21164PC microprocessor and drives the main memory array with the address, control, and clock signals. It also provides an interface to the 64-bit PCI I/O bus.

## 21174 Core Logic Chip

The 21174 chip provides the following functions:

- Serves as the interface between the 21164PC microprocessor, main memory (addressing and control), and the PCI bus. A three-entry CPU instruction queue is implemented to capture commands should the memory or I/O port be busy.
- Provides control to the Quick Switch chips to isolate the L2 cache from the main memory bus during private reads and writes.
- Generates the clocks, row, and column addresses for the SDRAM DIMMs, as well as all of the memory control signals (RAS, CAS, WE). All of the required SDRAM refresh control is contained in the 21174.
- Provides all the logic to map 21164PC noncacheable addresses to PCI address space, as well as all the translation logic to map PCI DMA addresses to system memory.

Two DMA conversion methods are supported:

- Direct mapping, in which a base offset is concatenated with the PCI address.
- Scatter-gather mapping, which maps an 8KB PCI page to any 8KB memory page. The 21174 contains an eight-entry scatter-gather translation lookaside buffer (TLB), where each entry holds four consecutive page table entries (PTEs).

### 4.2.2 Main Memory Interface

Quick Switches provide the interface between the 21164PC/L2 cache (**data\_h[127:0]**) and the memory/21174 (**mem\_data\_h[127:0]**). The AlphaPC 164SX supports four 168-pin unbuffered 72-bit or 64-bit SDRAM DIMM modules. Even parity is generated on the PCI bus.

The AlphaPC 164SX supports a maximum of 512MB of main memory. The memory is organized as two banks. Table 1–1 lists total memory options along with the corresponding DIMM sizes required. All CPU cacheable memory accesses and PCI DMA accesses are controlled and routed to main memory by the 21174 core logic chip.

The AlphaPC 164SX implements the alternate memory mode for SDRAM RAS and CAS control signals. Alternate memory mode is explained in the *21174 Core Logic Chip Technical Reference Manual*.

### 4.2.3 PCI Devices

The AlphaPC 164SX uses the PCI bus as the main I/O bus for the majority of peripheral functions. As Figure 4–3 shows, the board implements the ISA bus as an expansion bus for system support functions and for relatively slow peripheral devices.

**Figure 4–3 AlphaPC 164SX PCI Bus Devices**

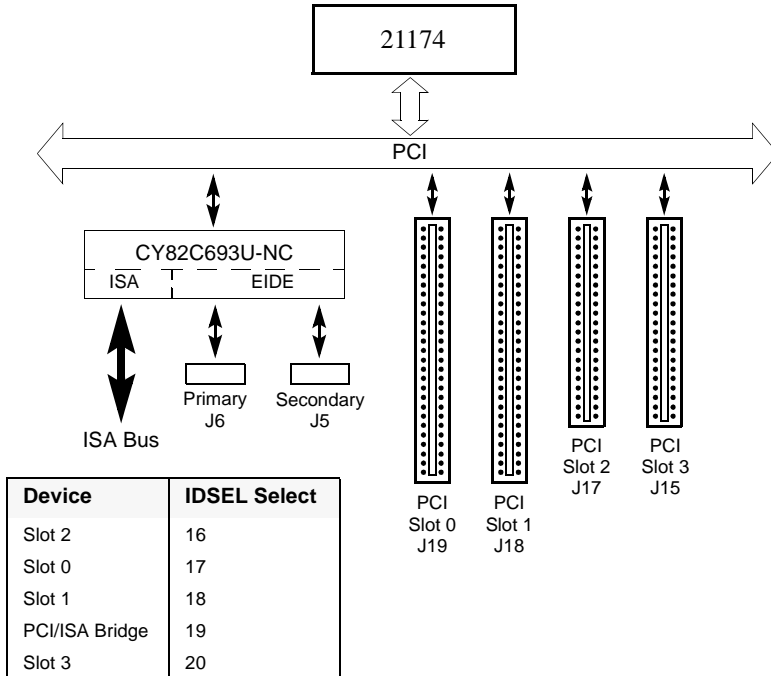

The PCI bus supports multiplexed, burst mode, read and write transfers. It supports synchronous operation of 33 MHz. It also supports either a 32-bit or 64-bit data path with 32-bit device support in the 64-bit configuration. Depending upon the configuration and operating frequencies, the PCI bus supports up to 264-MB/s (33 MHz, 64-bit) peak throughput. The PCI provides parity on address and data cycles. Three physical address spaces are supported:

- 32-bit memory space
- 32-bit I/O space
- 256-byte-per-agent configuration space

## ISA Bus Devices

The bridge from the 21164PC system bus to the 64-bit PCI bus is provided by the 21174 chip. It generates the required 32-bit PCI address for 21164PC I/O accesses directed to the PCI. It also accepts 64-bit double address cycles and 32-bit single address cycles. However, the 64-bit address support is subject to some constraints.

### 4.2.4 PCI/ISA Bridge Chip

The CY82C693U-NC chip provides the bridge between the PCI and the ISA bus, and between the PCI and the EIDE bus. It also incorporates the logic for the following:

- Keyboard/mouse controller – An 8042-compatible interface is brought out to separate 6-pin DIN connectors (J4).
- Real-time clock – A DS1287-compatible clock is backed up by a replaceable battery (XB1).
- A PCI interface (master and slave).
- An ISA interface (master and slave).
- PCI and ISA arbitration.

Refer to the Cypress document *CY82C693U hyperCache/Stand-Alone PCI Peripheral Controller with USB Data Sheet* for additional information.

### 4.2.5 PCI Expansion Slots

Four dedicated PCI expansion slots are provided on the AlphaPC 164SX. This allows the system user to add additional 32-bit or 64-bit PCI options. While both the 32-bit and the 64-bit slots use the standard 5-V PCI connector and pinout, +3.3 V is supplied for those boards that require it. The CY82C693U-NC chip provides the interface to the ISA expansion I/O bus.

## 4.3 ISA Bus Devices

Figure 4–4 shows the AlphaPC 164SX ISA bus implementation with peripheral devices and connectors. Two dedicated ISA expansion slots are provided. System support features such as serial lines, parallel port, and diskette controller are embedded on the module by means of an FDC37C669 combination controller chip.

### 4.3.1 Combination Controller Chip

The AlphaPC 164SX uses the Standard Microsystems Corporation FDC37C669 combination controller chip (see Figure 4–4). It is packaged in a 100-pin QFP configuration. The chip provides the following ISA peripheral functions:

- **Diskette controller** – Software compatible to the Intel N82077 FDC. Integrates the functions of the formatter/controller, digital data separator, write precompensation, and data-rate selection logic requiring no external filter components. Supports the 2.88-MB drive format and other standard diskette drives used with 5.25-inch and 3.5-inch media. FDC data and control lines are brought out to a standard 34-pin connector (J11). A ribbon cable interfaces the connector to one or two diskette drives.
- **Serial ports** – Two UARTs with full modem control, compatible with NS16450 or PC16550 devices, are brought out to two separate onboard, 9-pin D-subminiature connectors (J3).
- **Parallel port** – The bidirectional parallel port is brought out to an onboard 25-pin connector (J13). It can be brought out through a 25-pin female D-subminiature connector on the bulkhead of a standard PC enclosure.

An onboard clock generator chip supplies a 14.3-MHz reference clock for the diskette data separator and serial ports.

# ISA Bus Devices

Figure 4–4 AlphaPC 164SX ISA Bus Devices

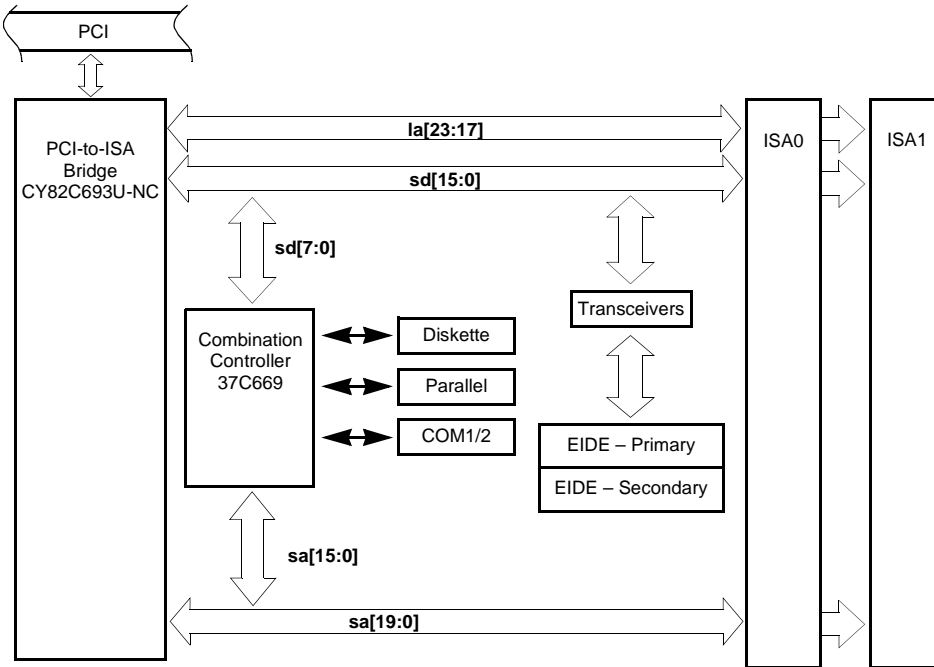

## 4.3.2 ISA Expansion Slots

Two ISA expansion slots are provided for plug-in ISA peripherals (J22 and J23).

## 4.3.3 ISA I/O Address Map

Table 4–1 lists the AlphaPC 164SX ISA I/O space address mapping.

Table 4–1 ISA I/O Address Map

(Sheet 1 of 2)

Range (hex)	Usage
000-00F	8237 DMA #1
020-021	8259 PIC #1
040-043	8253 timer
060-061	Ubus IRQ12 and NMI control

**Table 4–1 ISA I/O Address Map**

(Sheet 2 of 2)

Range (hex)	Usage
070	CMOS RAM address and NMI mask register
080-08F	DMA page registers
0A0-0A1	8259 PIC #2
0C0-0DF	8237 DMA #2
2F8-2FF	Serial port—COM2
370-377	Secondary diskette (floppy)
3BC-3BF	Parallel port—LPT1
3F0-3F7	Primary diskette (floppy)
3F8-3FF	Serial port—COM1

### 4.3.4 Flash ROM Address Map

After reset, the flash ROM is set to location 0. The 21174 supports cache fills and uncacheable reads from the flash ROM (that is, the 21174 does multiple reads to the flash ROM to assemble full octawords). The 21164PC can start executing directly from the flash ROM.

Once the boot code that was stored in the flash ROM has been executed, and memory has been initialized, the flash ROM is mapped to locations 87.C000.000–87.FFFF.FFFF.

## 4.4 Interrupts

Interrupts and general-purpose inputs are acquired by the 21174 through a free-running 32-bit external shift register. The **int\_sr\_load\_1** signal is asserted low to load the interrupts into the shift register. The **int\_clk** signal clocks the shift register contents into the 21174 through the **int\_sr\_in** pin. The shift register operates continuously at a rate of ¼ the chipset clock rate.

The state of each interrupt can be read through the interrupt request register. Note that the state of the interrupts will persist in the interrupt request register for up to 3 µs after the interrupt has been deasserted at the shift register. If the interrupt bit in the interrupt request register is not promptly cleared, a second interrupt might be taken before the shift register scans the deasserted value into the interrupt request

# Interrupts

register. Interrupts latched in the interrupt request register can be reset individually by writing a 1 to the bit to be cleared. This immediately clears the bit to avoid taking a second interrupt. Figure 4–5 shows the interrupt request register.

**Figure 4–5 Interrupt Request Register**

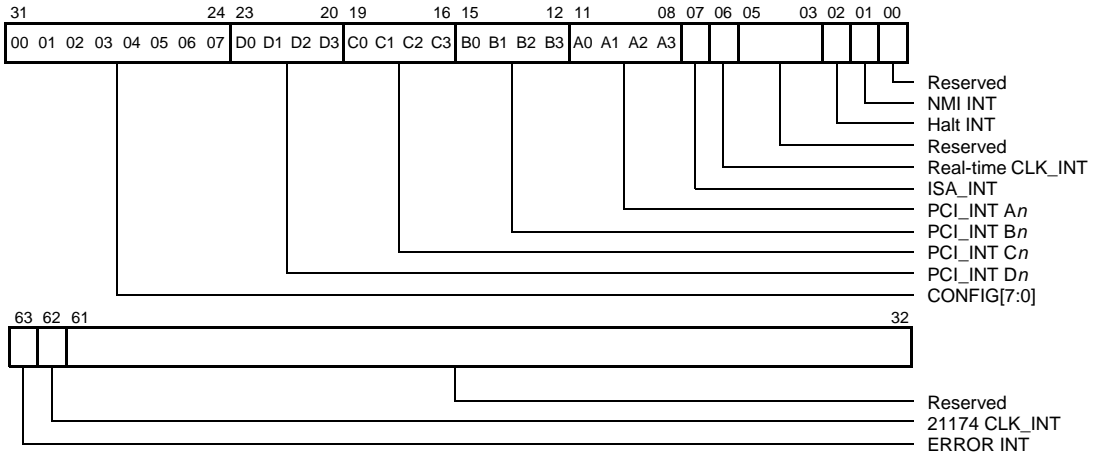

The interrupt mask register provides individual mask bits for each interrupt.

Table 4–2 lists the AlphaPC 164SX system interrupts, and Table 4–3 lists the ISA interrupts.

**Table 4–2 AlphaPC 164SX System Interrupts**

21164PC Interrupt	IPL <sup>1</sup>	Suggested Usage	AlphaPC 164SX Usage
<code>cpu_irq[0]</code>	20	Corrected system error	Reserved
<code>cpu_irq[1]</code>	21	—	PCI and ISA interrupts
<code>cpu_irq[2]</code>	22	Interprocessor and timer interrupts	TOY clock interrupt
<code>cpu_irq[3]</code>	23	—	Reserved
<code>pwr_fail_irq</code>	30	Powerfail interrupt	Reserved
<code>sys_mch_chk_irq</code>	31	System machine check interrupt	NMI and 21174 errors
<code>mch_hlt_irq</code>	—	Halt	Reserved

<sup>1</sup> IPL = interrupt priority level (fixed)

**Table 4–3 ISA Interrupts**

<b>Interrupt Number</b>	<b>Interrupt Source</b>
IRQ0	Internal timer
IRQ1	Keyboard
IRQ2	Interrupt from controller 2
IRQ3	COM2
IRQ4	COM1
IRQ5	Available
IRQ6	Diskette (floppy)
IRQ7	Parallel port
IRQ8# <sup>1</sup>	Reserved
IRQ9	Available
IRQ10	USB
IRQ11	Available
IRQ12	Mouse
IRQ13	Available
IRQ14	EIDE
IRQ15	EIDE

<sup>1</sup> The # symbol indicates an active low signal.

## System Clocks

### 4.5 System Clocks

Figure 4–6 shows the AlphaPC 164SX clock generation and distribution scheme.

The AlphaPC 164SX system includes input clocks to the microprocessor as well as clock distribution for the various system memory and I/O devices. There are other miscellaneous clocks for ISA bus support. System clocking can be divided into the following three main areas:

- **Microprocessor input clock** — The input clock runs at the operating frequency of the 21164PC microprocessor. The AlphaPC 164SX supports cycle times from 2.50 ns to 1.88 ns. This implies input clock frequencies from 400 MHz to 533 MHz. The clock is provided by using a synthesizer. The synthesizer's output is used as the input clock for the 21164PC.
- **Clock distribution** — Clock distribution includes the distribution of system clocks from the 21164PC microprocessor to the system logic. The AlphaPC 164SX clock distribution scheme is flexible enough to allow the majority of cycle-time combinations to be supported. Because the PCI is synchronous to the system clock generated by the 21164PC microprocessor, the PCI cycle time is a multiple of the 21164PC cycle time. This distribution scheme supports a PCI operation of 33 MHz.
- **Miscellaneous clocks** — The miscellaneous clocks include those needed for ISA and the combination controller. These clocks are provided by a crystal and a frequency generator with fixed scaling.

**Figure 4–6 AlphaPC 164SX System Clocks**

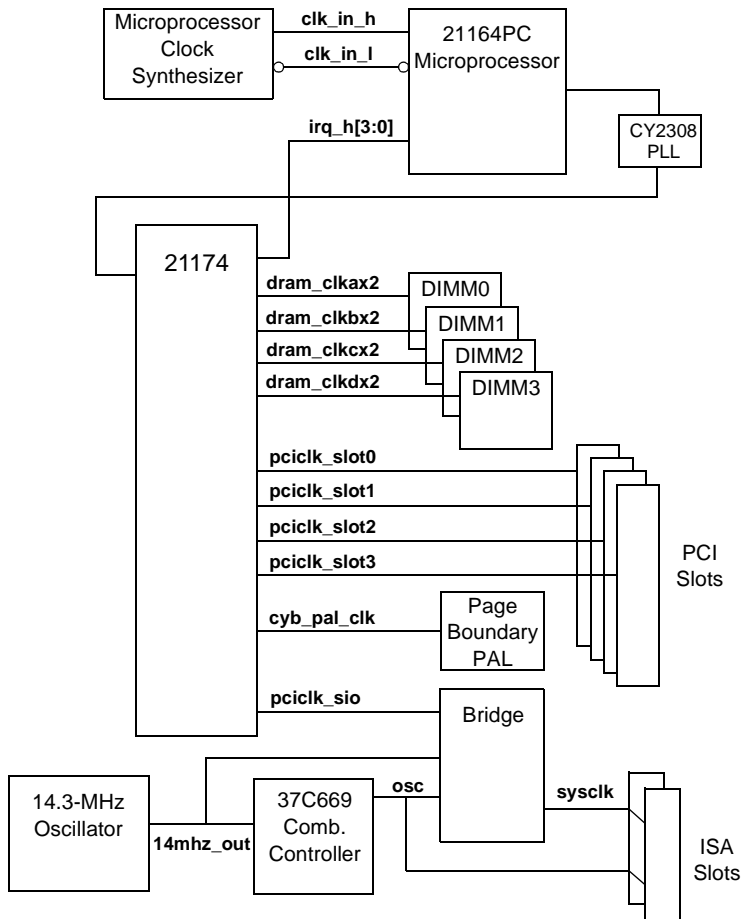

At system reset, the clock synthesizer is programmed to provide a 400-MHz clock to the 21164PC. The IRQ pins in the 21164PC are either pulled up or down to set the internal driver to divide by 6, providing a system clock of 66 MHz (**sys\_clk\_out1**).

If an operating frequency other than 400 MHz is selected by the configuration switches, the boot code changes the synthesizer output; the 21174 drives the correct divide ratio onto the IRQ lines and resets the CPU. If an invalid speed setting is selected, the system defaults to the operating speed of 400 MHz.



### 4.7 DC Power Distribution

The AlphaPC 164SX derives its system power from a user-supplied PC power supply. The power supply must provide +12 V dc and -12 V dc, -5 V dc, +3 V dc, and +5 V dc (**Vdd**). The dc power is supplied through power connector J2, as shown in Figure 4-8. Power is distributed to the board logic through dedicated power planes within the six-layer board structure.

Figure 4-8 shows that the +12 V dc, -12 V dc, and -5 V dc are supplied to ISA connectors J22 and J23. The +12 V dc and -12 V dc are supplied to ISA connectors and PCI32 connectors J15 and J17. The +12 V dc is also supplied to the CPU fan connector J14, and auxiliary fan connector J16. **Vdd** (+5.0 V) is supplied to ISA connectors, PCI32 connectors, and most of the board's integrated circuits. **Vdd** also drives the +2.5-V regulator, which supplies the 21164PC microprocessor.

Figure 4-8 AlphaPC 164SX Power Distribution

#### Power Connector J2

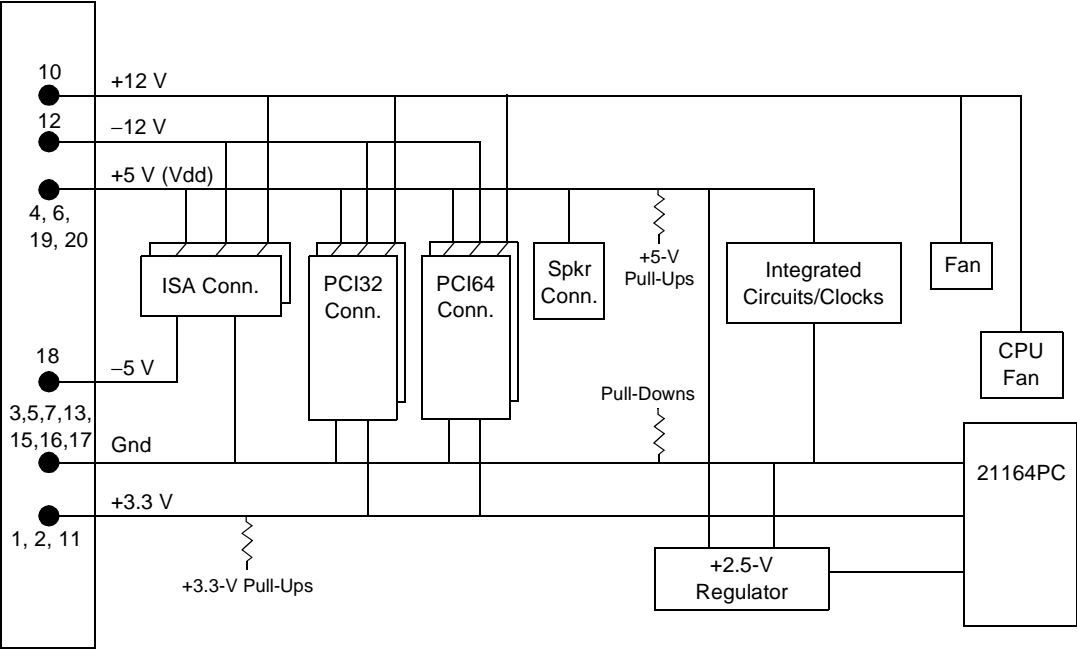

## Serial ROM and Debug Port Support

### 4.8 Serial ROM and Debug Port Support

Though it is not needed for normal operation, there is logic support for the use of a serial ROM and debug port. If an SROM is populated, the 21164PC loads its boot code from the SROM instead of from flash ROM. This code initializes the system, then transfers control to either the Mini-Debugger or the selected firmware, depending upon the setting of the configuration jumper.

---

## Upgrading the AlphaPC 164SX

For higher system speed or greater throughput, SDRAM memory can be upgraded by replacing DIMMs with those of greater size.

When configuring or upgrading SDRAM, observe the following rules:

- Each DIMM must be a 168-bit unbuffered version and have a frequency of 100 MHz.
- Each bank consists of two DIMMs and must be fully populated.
- Both DIMMs in the same bank must be of equal size.

### 5.1 Configuring SDRAM Memory

Although not an exhaustive list, Table 5–1 lists the tested SDRAM memory configurations available. As additional configurations become available, they will be posted in online revisions of this manual on the Alpha OEM World Wide Web Internet site. See Appendix A for the URL.

For a list of vendors who supply components and accessories for the AlphaPC 164SX, see Appendix A.

Refer to Figure 2–1 for DIMM connector locations.

**Note:** 1Mb × 72 and 1Mb × 64 DIMMs are not supported.

## Upgrading SDRAM Memory

**Table 5–1 AlphaPC 164SX SDRAM Memory Configurations**

Total Memory	Bank 0 <sup>1</sup>		Bank 1 <sup>1</sup>	
	J7	J8	J9	J10
32MB	2Mb × 72	2Mb × 72	—	—
64MB	2Mb × 72	2Mb × 72	2Mb × 72	2Mb × 72
	4Mb × 72	4Mb × 72	—	—
96MB	4Mb × 72	4Mb × 72	2Mb × 72	2Mb × 72
128MB	4Mb × 72	4Mb × 72	4Mb × 72	4Mb × 72
	8Mb × 72	8Mb × 72	—	—
160MB	8Mb × 72	8Mb × 72	2Mb × 72	2Mb × 72
192MB	8Mb × 72	8Mb × 72	4Mb × 72	4Mb × 72
256MB	8Mb × 72	8Mb × 72	8Mb × 72	8Mb × 72
	16Mb × 72	16Mb × 72	—	—
512MB	16Mb × 72	16Mb × 72	16Mb × 72	16Mb × 72

<sup>1</sup> 64-bit-wide DIMMs can also be used.

## 5.2 Upgrading SDRAM Memory

You can upgrade memory in the AlphaPC 164SX by adding more DIMMs or replacing the ones you have with a greater size. Refer to Figure 2–1 for DIMM connector locations.

Use the following general guidelines:

1. *Observe antistatic precautions.* Handle DIMMs only at the edges to prevent damage.
2. Remove power from the system.

3. Align the DIMM so that the notch in the DIMM matches the key in the socket.
4. Firmly push the DIMM straight into the connector. Ensure that the DIMM snaps into the plastic locking levers on both ends.
5. Restore power to the system.

### 5.3 Increasing Microprocessor Speed

This section describes how to complete the following actions to increase microprocessor speed:

- Replace the Alpha 21164PC microprocessor with an Alpha chip that has a higher speed rating.
- Reconfigure the clock divisor switches.

#### 5.3.1 Preparatory Information

**Caution:** Static-Sensitive Component – Due to the sensitive nature of electronic components to static electricity, anyone handling the microprocessor *must* wear a properly grounded antistatic wriststrap. Use of antistatic mats, ESD approved workstations, or exercising other good ESD practices is recommended.

An Alpha 21164PC microprocessor with a higher speed rating is available from your local distributor. See Appendix A for information about supporting products.

When replacing the microprocessor chip, also replace the thermal conducting GRAFOIL pad. See Appendix A for information about the parts kit, which includes the heat sink, GRAFOIL pad, two hex nuts, heat-sink clips, 52-mm fan, and four screws.

#### 5.3.2 Required Tools

The following tools are required when replacing the microprocessor chip:

A TS30 manual nut/torque driver (or equivalent) with the following attachments is required to affix the heat sink and fan to the microprocessor's IPGA package:

- 1/4-inch hex bit
- 3/8-inch socket with 1/4-inch hex drive
- #2 Phillips-head screwdriver bit

## Increasing Microprocessor Speed

### 5.3.3 Removing the 21164PC Microprocessor

Remove the microprocessor currently in place at location U31 by performing the following steps:

1. Unplug the fan power/sensor cable from connector J14 (see Figure 2–1).
2. Remove the four 6–32 × 0.625-inch screws that secure the fan to the heat sink.
3. Remove the fan.
4. If the sink/chip/fan clip is used, remove it by unhooking its ends from around the ZIF socket retainers.
5. Using a 3/8-inch socket, remove the two nuts securing the heat sink to the microprocessor studs.
6. Remove the heat sink by gently lifting it off the microprocessor.
7. Remove and discard the GRAFOIL heat conduction pad.
8. Thoroughly clean the bottom surface of the heat sink before affixing it to the new microprocessor.
9. Lift the ZIF socket actuator handle to a full 90° angle.
10. Remove the microprocessor chip by lifting it straight out of the socket.

### 5.3.4 Installing the 21164PC Microprocessor

Install the new microprocessor in location U31 by performing the following steps:

**Note:** Install the heat sink only after the microprocessor has been assembled to the ZIF socket.

1. Observe antistatic precautions.
2. Lift the ZIF socket actuator handle to a full 90° angle.
3. Ensure that all the pins on the microprocessor package are straight.
4. The ZIF socket and microprocessor are keyed to allow for proper installation. Align the microprocessor, with its missing AD01 pin, with the corresponding plugged AD01 position on the ZIF socket. Gently lower into position.
5. Close the ZIF socket actuator handle to its locked position.
6. Install the heat sink and heat-sink fan as directed in the following steps. A heat-sink/fan kit is available from the vendor listed in Appendix A. Refer to Figure 5–1 for heat-sink and fan assembly details.

Figure 5-1 Fan/Heat-Sink Assembly

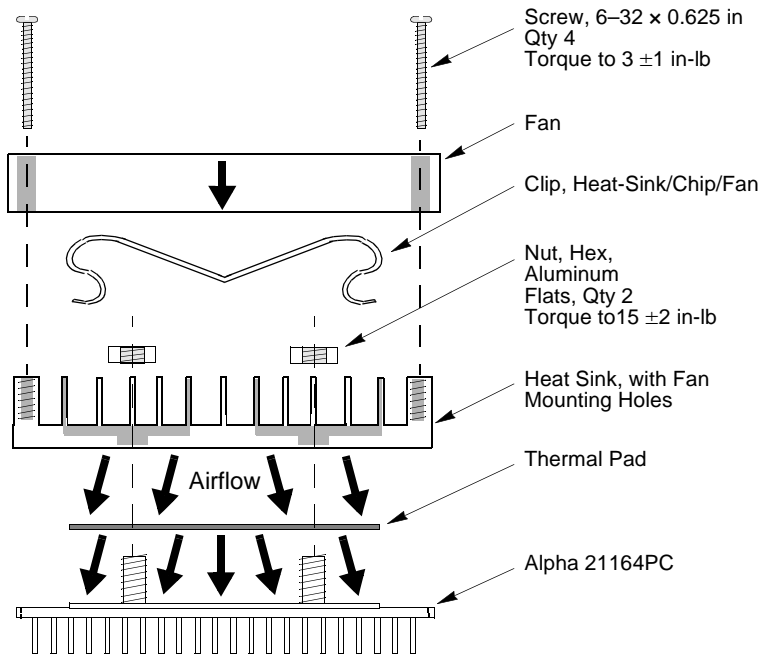

- a. Put the GRAFOIL thermal pad in place. The GRAFOIL pad is used to improve the thermal conductivity between the chip package and the heat sink by replacing micro air pockets with a less insulative material. Perform the following steps to position the GRAFOIL pad:
  1. Perform a visual inspection of the package slug to ensure that it is free of contamination.
  2. Wearing clean gloves, pick up the GRAFOIL pad. *Do not* perform this with bare hands because skin oils can be transferred to the pad.
  3. Place the GRAFOIL pad on the gold-plated slug surface and align it with the threaded studs.

## Increasing Microprocessor Speed

- b. Attach the microprocessor heat sink. The heat-sink material is clear anodized, hot-water-sealed, 6061-T6 aluminum. The nut material is 2011-T3 aluminum (this grade is critical). Perform the following steps to attach the heat sink:
  1. Observe antistatic precautions.
  2. Align the heat-sink holes with the threaded studs on the ceramic package.
  3. Handle the heat sink by the edges and lower it onto the chip package, taking care not to damage the stud threads.
  4. Set a calibrated torque driver to 15 in-lb,  $\pm 2$  in-lb, (2.3 Nm,  $\pm 0.2$  Nm). The torque driver should have a mounted 3/8-inch socket.
  5. Insert a nut into the 3/8-inch socket, place on one of the studs, and tighten to the specified torque. Repeat for the second nut.
  6. If the sink/chip/fan clip is used, properly install it by positioning it over the assembly and hooking its ends around the ZIF socket retainers.
- c. Attach the heat-sink fan assembly:
  1. Place the fan assembly on top of the heat sink, aligning the fan mounting holes with the corresponding threaded heat-sink holes. Align the fan so that the fan power/sensor wires exit the fan closest to connector J14 (see Figure 2-1). Fan airflow must be directed into the heat sink (fan label facing down toward the heat sink).
  2. Using a calibrated torque driver set to 3 in-lb,  $\pm 1$  in-lb, secure the fan to the heat sink with four 6-32  $\times$  0.625-inch screws.
  3. Plug the fan power/sensor cable into connector J14.

**Note:** When installing the microprocessor, you must change the frequency of its clock output by setting the system clock divisor switches, as described in Section 2.2.

---

# Support, Products, and Documentation

## A.1 Customer Support

The Alpha OEM website provides the following information for customer support.

URL	Description
<a href="http://www.digital.com/alphaoem">http://www.digital.com/alphaoem</a>	Contains the following links: <ul style="list-style-type: none"><li>• <b>Developers' Area:</b> Development tools, code examples, driver developers' information, and technical white papers</li><li>• <b>Motherboard Products:</b> Motherboard details and performance information</li><li>• <b>Microprocessor Products:</b> Microprocessor details and performance information</li><li>• <b>News:</b> Press releases</li><li>• <b>Technical Information:</b> Motherboard firmware and drivers, hardware compatibility lists, and product documentation library</li><li>• <b>Customer Support:</b> Feedback form</li></ul>

---

## Supporting Products

### A.2 Supporting Products

This section lists sources for components and accessories that are not included with the AlphaPC 164SX.

#### A.2.1 Memory

Dual inline memory modules (DIMMs) are available from a variety of vendors. For a list of the qualified vendors, visit the Alpha OEM World Wide Web Internet site at URL:

<http://www.digital.com/alphaoem>

Click on **Technical Information**.

Then click on **Alpha OEM Hardware Compatibility List**.

#### A.2.2 Thermal Products

Components included in this heat-sink and fan solution are heat sink, GRAFOIL pad, two hex nuts, heat-sink clips, 52-mm fan, and four screws. These are available from:

**United Machine and Tool Design Company, Inc.**

18 River Road  
P.O. Box 168  
Fremont, NH 03044  
Phone: 603-642-5040  
Fax: 603-642-5819  
PN 70-33148-01

#### A.2.3 Power Supply

An ATX form-factor power supply, suitable for use with the AlphaPC 164SX (+3.3 V, +5 V, -5 V, +12 V, -12 V), is available from:

**Quantum Power Labs, Inc.**

1410 Gail Borden Place C-4  
El Paso, TX 79935  
Phone: 915-599-2688  
Fax: 915-599-2699  
PN AP2-5300FRV (300 W)

## Antec, Inc.

2859 Bayview Drive  
Fremont, CA 94538  
Phone: 510-770-1200, ext. 313  
PN PP-253V (250 W)

## A.2.4 Enclosure

An enclosure, suitable for housing the AlphaPC 164SX and its power supply, is available from:

### Delta Axxion Technology

1550 Northwestern  
El Paso, TX 79912  
Phone: 915-877-5288  
PN DL17

## A.3 Alpha Products

To order the AlphaPC 164SX motherboard, contact your sales office. The following tables list some of the Alpha products available.

**Note:** The following products and order numbers might have been revised. For the latest versions, contact your local distributor.

<b>Chips</b>	<b>Order Number</b>
Alpha 21164PC microprocessor (400 MHz)	211PC-01
Alpha 21164PC microprocessor (533 MHz)	211PC-03

Motherboard kits include the motherboard and motherboard user's manual.

<b>Motherboard Kits</b>	<b>Order Number</b>
AlphaPC 164SX Motherboard Kit for Windows NT	21A05-A0
AlphaPC 164SX Motherboard Kit for DIGITAL UNIX	21A05-A1

## Alpha Documentation

Design kits include full documentation and schematics. They do not include related hardware.

Design Kits	Order Number
AlphaPC 164SX Motherboard Software Developer's Kit (SDK) and Firmware Update	QR-21A04-12

### A.4 Alpha Documentation

The following table lists some of the available Alpha documentation. You can download Alpha documentation from the Alpha OEM World Wide Web Internet site:

<http://www.digital.com/alphaoem>

Title	Order Number
Alpha Architecture Reference Manual <sup>1</sup>	EY-W938E-DP
Alpha Architecture Handbook	EC-QD2KB-TE
Alpha 21164PC Microprocessor Hardware Reference Manual	EC-R2W0A-TE
Alpha 21164PC Microprocessor Data Sheet	EC-R2W1A-TE

<sup>1</sup>To purchase the *Alpha Architecture Reference Manual*, contact your sales office or call Butterworth-Heinemann (DIGITAL Press) at 1-800-366-2665.

If you have feedback about the Alpha technical documentation, please send your comments to [alpha.techdoc@compaq.com](mailto:alpha.techdoc@compaq.com).

## A.5 Third-Party Documentation

You can order the following third-party documentation directly from the vendor.

Title	Vendor
PCI Local Bus Specification, Revision 2.1 PCI Multimedia Design Guide, Revision 1.0 PCI System Design Guide PCI-to-PCI Bridge Architecture Specification, Revision 1.0 PCI BIOS Specification, Revision 2.1	PCI Special Interest Group U.S. 1-800-433-5177 International 1-503-797-4207 Fax 1-503-234-6762
CY82C693U hyperCache/Stand-Alone PCI Peripheral Controller with USB Data Sheet	Cypress Semiconductor Corporation 3901 North First Street San Jose, CA 95134 Phone: 1-800-858-1810
Super I/O Floppy Disk Controller with Infrared Support (FDC37C669) Data Sheet	Standard Microsystems Corporation 80 Arkay Drive Hauppauge, NY 11788 Phone: 1-800-443-7364 Fax: 1-516-231-6004



## Numerics

---

21164 microprocessor. *See* Microprocessor.  
21174 Core logic chip. *See* Core logic chip.  
37C669. *See* Combination controller.

## A

---

Abbreviations, x  
Airflow requirements, 3-2  
ATX hole specification, 3-3  
ATX I/O shield requirements, 3-4

## B

---

Bcache  
    interface, 4-2  
    subsystem, 1-4  
Bit notation, xi  
Block diagram, 1-2

## C

---

CAS, 4-4  
Clocks, 1-5  
    14.3-MHz reference, 4-7  
Combination controller, 1-4, 4-6, 4-7  
Communication ports, 4-7  
Component list, 2-3

Components and features, 1-1  
Connectors, 2-3  
    pinouts, 2-6 to 2-14  
Conventions  
    numbering, xii  
Core logic chip, ?? to 4-4  
CPU. *See* Microprocessor.  
Current  
    dc ampere requirements, 3-1

## D

---

Data field size, xi  
Data units, xi  
DC power requirements, 3-1  
Debug monitor  
    system support, 1-5  
Design support, 1-6  
DIGITAL UNIX  
    SDK support, 1-6  
    SRM console firmware, 1-6  
Dimensions  
    motherboard, 3-2  
Direct mapping, 4-4  
Diskette controller, 4-7  
DMA conversion, 4-4

## E

---

Environmental requirements, 3-2  
Extents and ranges, xii

## F

---

FDC37C669. *See* Combination controller.  
Flash ROM  
    AlphaBIOS firmware, 1-5

## I

---

I/O shield dimensions, 3-4  
Interface  
    main memory, 4-4  
Interrupts, 4-9  
    system assignment, 4-10  
INTnn, xi  
ISA  
    bus, 4-5  
    devices, 4-6  
    expansion slots, 4-6  
    interface, 1-4

## J

---

Jumpers  
    Bcache size, 2-5

## K

---

Keyboard  
    controller, 4-6

## M

---

Mapping  
    direct (DMA), 4-4  
    scatter-gather, 4-4

## Memory

    alternate mode, 4-4  
    main, 4-4  
    SDRAM DIMM pinouts, 2-9  
    subsystem, 1-3

## Microprocessor

    speeds, 1-1  
    upgrading, 5-1 to 5-6

## Motherboard

    ATX hole specification, 3-3  
    ATX I/O shield, 3-4  
    component descriptions, 2-3  
    dimensions, 3-2

## Mouse

    controller, 4-6

## N

---

Numbering convention, xii

## O

---

## Operating systems

    software support, 1-5

Ordering products and documentation, A-3

## P

---

## Packaging

    21174 chip, 4-3

Parallel port, 4-7

## PCI

    21174 role, 4-6  
    bus, 4-5  
    bus speed, 4-5  
    device implementation, 4-5  
    expansion slots, 4-6  
    interface, 1-4

## Pinouts

    connectors, 2-6 to 2-14

## Power

    distribution, 4-15  
    requirements, 3-1

Power supply  
    dc ampere requirements, 3-1  
    wattage requirements, 3-1  
Processor. *See* Microprocessor.  
PTE, 4-4

## R

---

Ranges and extents, xii  
RAS, 4-4  
Reset, 4-14  
RO  
    definition, x  
RW  
    definition, x

## S

---

Scatter-gather  
    mapping, 4-4  
SDK, 1-5 to 1-6  
Serial ports, 4-7  
Serial ROM. *See* SROM.  
Shield dimensions  
    I/O, 3-4  
Software support, 1-5  
SRM Console, 1-6  
SROM, 4-16  
Support  
    technical, A-1  
System  
    components and features, 1-1  
    software support, 1-5

## T

---

Time-of-year clock, 4-6  
TLB, 4-4

## U

---

UARTs, 4-7  
UNDEFINED  
    definition, xiii  
UNIX. *See* DIGITAL UNIX.  
UNPREDICTABLE  
    definition, xiii  
Upgrading  
    microprocessor, 5-3

## W

---

Windows NT  
    AlphaBIOS firmware, 1-5  
    SDK support, 1-6  
WO  
    definition, x

