

Curry

INSTRUCTION MANUAL

TU55 DECtape 55

TU55
DECtape 55
INSTRUCTION MANUAL

1st Printing November 1966
2nd Printing February 1967
3rd Printing June 1967
4th Printing October 1968
5th Printing November 1968

Copyright © 1968 by Digital Equipment Corporation

The following are registered trademarks of Digital
Equipment Corporation, Maynard, Massachusetts:

DEC
FLIP CHIP
DIGITAL

PDP
FOCAL
COMPUTER LAB

CONTENTS

Page

CHAPTER 1 INTRODUCTION AND DESCRIPTION

1.1	General Description	1-1
1.2	Scope of Manual	1-2
1.3	Pertinent Documents	1-2
1.3.1	Manuals	1-2
1.3.2	Engineering Drawings	1-2
1.3.3	New Module News Bulletins	1-3
1.4	Functional Description	1-3
1.5	Physical Description	1-4
1.5.1	Electrical Details	1-6
1.6	TU55 Performance Characteristics	1-9

CHAPTER 2 THEORY OF OPERATION

2.1	Block Diagram Analysis	2-1
2.2	Detailed Descriptions	2-4
2.2.1	Interface	2-4
2.2.2	Unit Select Lines	2-5
2.2.3	Command Lines	2-5
2.2.4	WRITE ENABLE Signal	2-5
2.2.5	Interface Connections	2-6
2.2.6	Read/Write Head	2-6
2.2.7	Tape Motion Control	2-6
2.2.8	Remote or Programmed Control	2-6
2.2.9	Local (Manual) Control	2-7
2.2.10	Motor Control	2-7
2.2.11	Transport Selected Signal	2-8
2.3	Module Descriptions	2-9
2.3.1	Type R303 Integrating One Shot (Delay)	2-9
2.3.2	Type W513 Level Amplifier	2-10
2.3.3	Type G850 SCR Motor Driver	2-11

CONTENTS (Cont)

		Page
CHAPTER 3 OPERATION		
3.1	Introduction	3-1
3.2	Controls and Indicators	3-1
3.2.1	Operating Notes	3-1
3.3	Loading Tape	3-1
CHAPTER 4 MAINTENANCE		
4.1	Equipment Required	4-1
4.2	Preventive Maintenance	4-1
4.2.1	Weekly Schedule	4-1
4.2.2	Monthly Schedule	4-2
4.3	Tape Tension and Transport Stop Adjustment	4-2
4.4	Head Output Check	4-3
4.5	Head-Skew Check	4-4
4.6	Write Enable Circuit Check	4-5
4.7	Troubleshooting	4-6
4.8	Recommended Spare	4-7
CHAPTER 5 ENGINEERING DRAWINGS		
5.1	Introduction	5-1
5.2	Circuit Symbols	5-1
5.3	Logic Signal Symbols	5-1
5.3.1	Logic Levels	5-1
5.3.2	FLIP CHIP Pulses	5-1
5.4	Semiconductor Substitution	5-4
ILLUSTRATIONS		
1-1	Type TU55 DECTape Transport	1-1
1-2	Hub and Reel Assembly	1-5
1-3	Arrangement of DECTape Head	1-6
1-4	Type TU55 DECTape Transport, Rear View	1-7

ILLUSTRATIONS (Cont)

		Page
1-5	TU55 Interface Connections	1-8
2-1	DECtape Transport TU55 Block Diagram	2-1
2-2	Head Connections	2-4
2-3	Schematic of R303 Integrating One-Shot	2-10
2-4	Schematic of G850 SCR Motor Drive	2-11
4-1	Module Adjustment Trimports	4-3
5-1	DEC Symbols	5-2
5-2	FLIP CHIP R-Series Pulse	5-4
5-3	FLIP CHIP B-Series Pulse	5-4

Module Schematics

Solid State DECtape Transport, TU55-0-2	5-5
Module Utilization List, TU55-0-5	5-7
Bus Bar for TU55, TU55-0-4	5-7
Relay, G851	5-8
Diode Cluster, R002	5-8
Inverter, R107	5-9
Diode Gate, R111	5-9
Dual Flip-Flop, R202	5-10
Integrating One-Shot, R303	5-10
Solenoid Driver, W040	5-11
Level Amplifier, W513	5-11

TABLES

1-1	Summary of Equipment Characteristics for the TU55 DECtape Transport	1-9
2-1	Motor and Brake Operation Truth Table	2-9
3-1	Functions of Controls and Indicators	3-2
4-1	Recommended Maintenance Equipment	4-1
4-2	Recommended Spare Parts	4-7
5-1	Semiconductor Substitution	5-4

CHAPTER 1
INTRODUCTION AND DESCRIPTION

1.1 GENERAL DESCRIPTION

The Type TU55 DECtape Transport (see figure 1-1) is a solid-state, bidirectional, magnetic-tape handling device designed and manufactured by the Digital Equipment Corporation (DEC) for use in DEC digital computer systems. When used with a suitable DECtape control system, the TU55 provides a fixed-address magnetic-tape facility for high-speed loading, readout, and program updating. The DECtape control system directs the transport to read forward or in reverse, to write forward or in reverse, to stop, and to go. The TU55 contains tape handling elements, drive mechanisms, and solid-state switching circuits which switch the tape head onto a master bus system and interpret command instructions from the control unit. The highly reliable solid-state switching circuits in the TU55 are completely compatible with the Type 555 DECtape Transport (which uses relay switching) and may be used to modify and expand systems employing this type of transport.

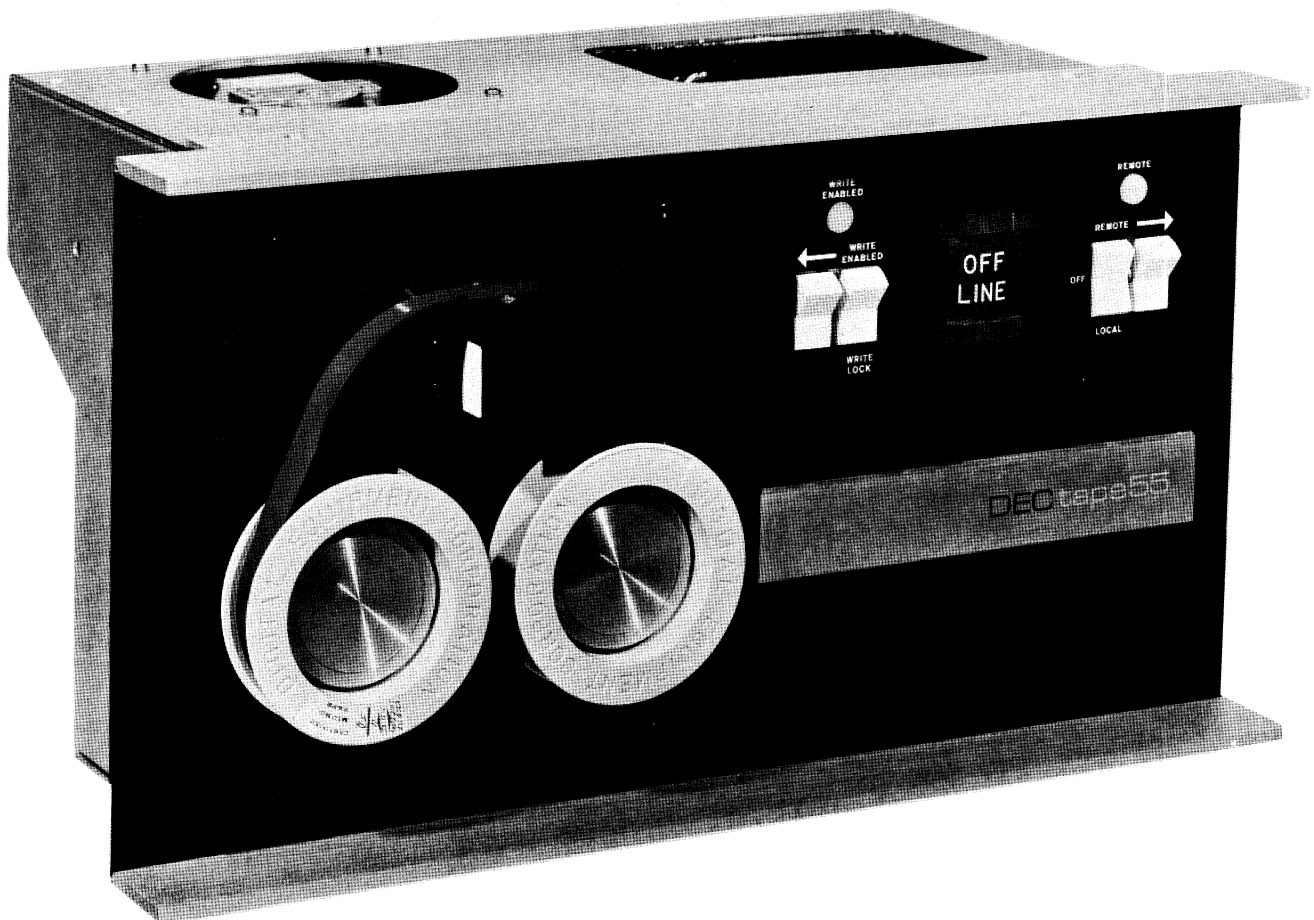

Figure 1-1 Type TU55 DECtape Transport

1.2 SCOPE OF MANUAL

This instruction manual is intended to aid personnel in the maintenance of the TU55 DECtape Transport. The equipment is discussed primarily from a maintenance point of view, but some information is given on the operation of its associated controls and indicators. The documents listed below provide operational information required for programming.

Since the transport is one element of a computer/control/transport system, the reader should know the basic internal operations of both the computer and control. Of special importance are the sections concerning program interrupts, programmed in/out transfers, and the databreak facility in the computer; and the select and motion control logic in the external DECtape control. Detailed descriptions of the tape format, instruction repertoire, and programming practice for using the TU55 with a particular computer is described in the user handbook for the computer. Control information for the TU55 can be obtained from the maintenance manual for the DECtape control system used with the transport.

1.3 PERTINENT DOCUMENTS

The following documents provide source information relative to the use of the DECtape Transport Type TU55.

1.3.1 Manuals

Digital FLIP CHIP Modules Catalog, C-105

PDP-7 User Handbook, F-75

PDP-8 User Handbook, F-85

DECtape Control 550 Instruction Manual, H-550

DECtape Control 551 Instruction Manual, H-551

DECtape Control 552 Instruction Manual, H-552

DECtape Control TC01 Instruction Manual, DEC-08-I3AB-D

DECtape PDP-8 Programming Manual, Digital-8-27-U

1.3.2 Engineering Drawings

A set of reduced engineering drawings for the TU55 is contained in chapter 5. These drawings are in addition to the complete set of full-size drawings forwarded with each TU55. As explained in chapter 5 all maintenance personnel should use only the full size engineering drawings for work on the equipment because these drawings show variations peculiar to an individual installation.

1.3.3 New Module News Bulletins

G850 SCR Motor Driver

G851 Relay

W513 Level Amplifier

In addition to the above documents, complete sets of Library Programs are available for each computer using DECtape systems.

1.4 FUNCTIONAL DESCRIPTION

The TU55 Transport provides a read/write head for recording and playback of information on five channels of the 0.75-inch tape. Each channel consists of two nonadjacent coils which are wired in series. Thus, information on one track combines with redundant information on another to create a single signal. Connections from the read/write head are made directly to the external control unit which contains the read and write amplifiers as well as the command logic for the selection and remote control of tape motion.

The left half of the front panel (see Figure 1-1) contains the tape deck with reels and reel motors, tape guides, and the read/write head; the right half is the local control panel with rocker switches for selection and manual operation. The 600-rpm induction motors that drive the reel hubs directly control tape motion. No capstans, pinch rollers, or drag pads contact the tape.

The logic circuits of the TU55 command tape movement in either direction over the read/write heads. Solid-state switching circuits completely control the tape drive motors. These circuits govern the torque applied to each reel motor to transport the tape across the head in accordance with specific commands (i.e., go, forward, reverse, stop).

In normal tape movement, full torque is applied to the take-up reel, thus establishing the direction of motion. Reduced torque, applied to the trailing reel, maintains proper tape tension. Tape motion is bidirectional so that either reel can serve as the take-up reel. The DECtape system uses the so-called Manchester phase recording technique rather than an amplitude sensing technique; thus, tape speed need not be a precisely controlled parameter. Actually, the speed varies $\pm 20\%$, depending upon the diameter of the tape pack on the take-up reel. An electromagnetic brake mounted on each motor shaft achieves a positive stop by braking the trailing reel at the end of a motion command. The take-up reel motor continues to apply partial torque to take up tape slack. Whenever the tape is motionless, one of the two reel brakes is applied opposite to the direction of the last tape movement.

Tape movement is controlled either by commands originating in the computer and applied to the TU55 via a suitable DECTape control system, or by commands generated through manual operation of rocker type switches located on the front panel of the transport. Typical DECTape control systems which allow transfer of information between the computer and the TU55 are as follows:

<u>Computer</u>	<u>Typical DECTape Control System</u>
PDP-1, -4 and -7	Type 550
PDP-6	Type 551
PDP-5 and -8	Type 552
PDP-8	TC01
PDP-9	TC02

Manual control is used to mount new reels of tape on the TU55 or as a quick maintenance check for proper operation of the control logic in moving the tape.

External DECTape control systems may control up to eight individually addressed TU55s to read or write tape. The operator may select the address of each drive by adjusting the thumbwheel selector at the center of the TU55 local control panel (see figure 1-1). The operator may also place the drive off-line by a setting on the same thumbwheel or by switching the drive for local operation. In local operation, the head is disconnected and the rocker switches on the local control panel regulate tape motion.

1.5 PHYSICAL DESCRIPTION

All components of the TU55 are mounted on a preformed and assembled chassis. Roller slides that allow easy access to the top, sides, and rear of the drive hold the chassis in a standard DEC bay. Double doors in the front and rear are held closed by magnetic latches. Power supplies and controls are mounted on the rear of the DEC bay. Generally, the transport is mounted with others in the same bay that contains the DECTape control system.

The tape deck is machined from 3/8-inch cast aluminum plate and held to the chassis by cap screws at the corners. Reel motors, tape guides and the head are secured only to the deck. This arrangement preserves the integrity of the tape alignment by the rigidity of the deck plate. Heavy extruded aluminum plates at the top and bottom front of the chassis serve as bumpers to protect the deck and control panel. The head is mounted in direct contact with the deck and is secured at both sides by brackets. Head azimuth is set during manufacture of the drive and cannot be adjusted in the field.

CAUTION

No attempt should be made to loosen the brackets and change the head position.

Reel motors are held by four cap screws (hidden by the reel hubs) from the front of the deck. At the rear of the shaft (which extends from both ends) is the electromagnetic brake. At the front, the shaft has a flat for securing the reel hub by a single Allen-head set screw. The hubs are flanged at the rear and have an annular spring resting in a slot cut into the reel circumference. Beneath the spring in the slot is a rubber ring seal which causes the spring to protrude above the slot to secure the reel (see figure 1-2). The reel is a 1-piece mold of phenolic composition. The inside circumference at the back of the reel fits the hub. In front, however, the inside circumference is slightly larger, allowing the hub spring to expand outward and to secure the reel. The clearance between the rear of the reel hub and the tape deck is nominally 15 mils, but may vary on individual machines to guarantee proper tape alignment in the guides. The guides are machined from aluminum and have a curvature designed to maintain air-film lubrication between the tape and guides as long as tape is in motion. A fan mounted on the top chassis plate continuously blows cooling air over the reel motors.

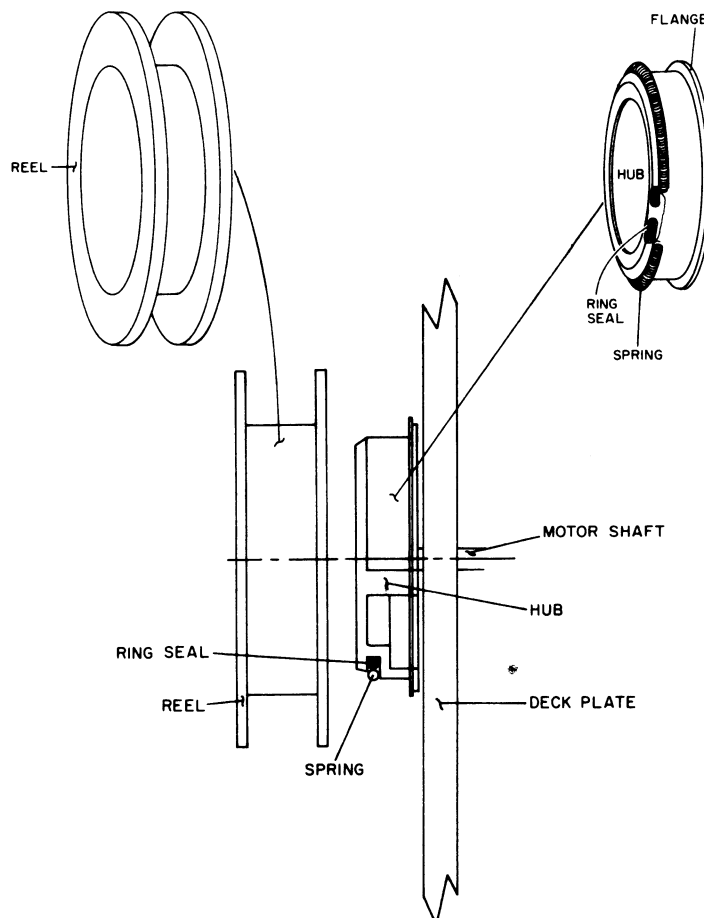

Figure 1-2 Hub and Reel Assembly

The redundantly paired tracks that form the five channels on the head are illustrated schematically in figure 1-3. Three track pairs are used for data; the remaining pairs are used as timing and control information. The two timing tracks are on the outside at opposite sides of the tape. Just inside these are the two tracks for the mark channel, the contents of which signify to the external control the type of information in the data channels. The six tracks for these data channels are grouped at the center, where they are least affected by skew. Since writing may take place in the data channels while reading takes place simultaneously in the timing and mark channels, the tracks for the latter channels are separated slightly from the data channel tracks to allow room for additional shielding.

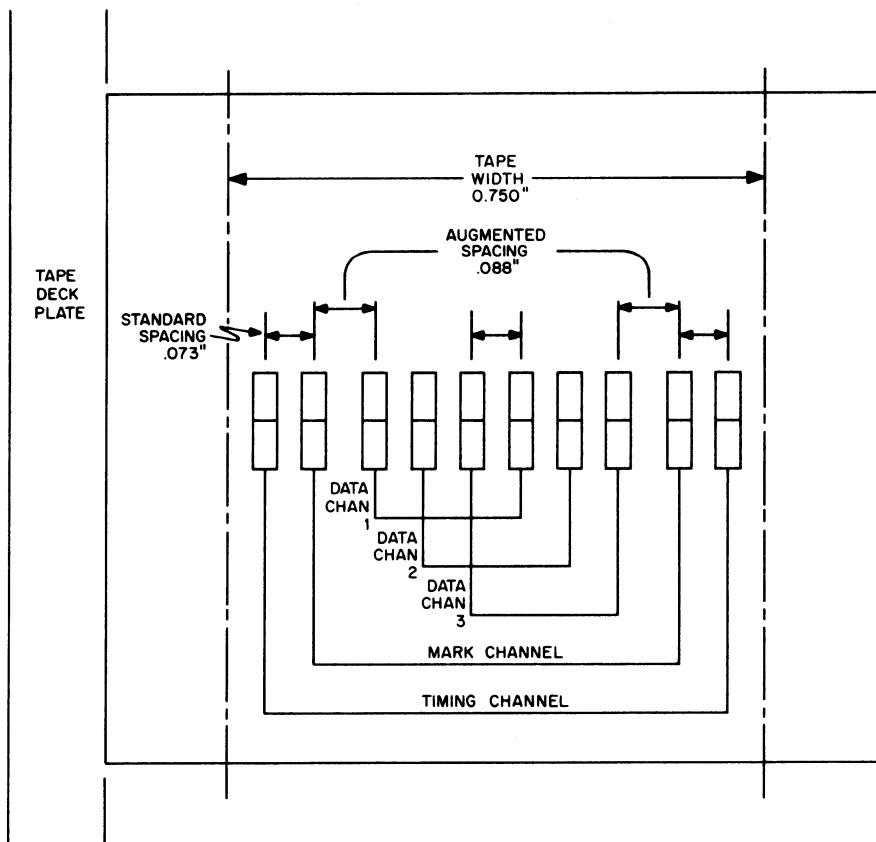

Figure 1-3 Arrangement of DECTape Head

1.5.1 Electrical Details

The TU55 requires the DEC standard +10 and -15 vdc power levels at the terminal-tab connectors on the rear panel (figure 1-4). These dc levels are normally provided from power supplies associated with the DECTape control system. AC power (105-125v, 60 cps) is connected at the 3-terminal receptacle on the rear panel.

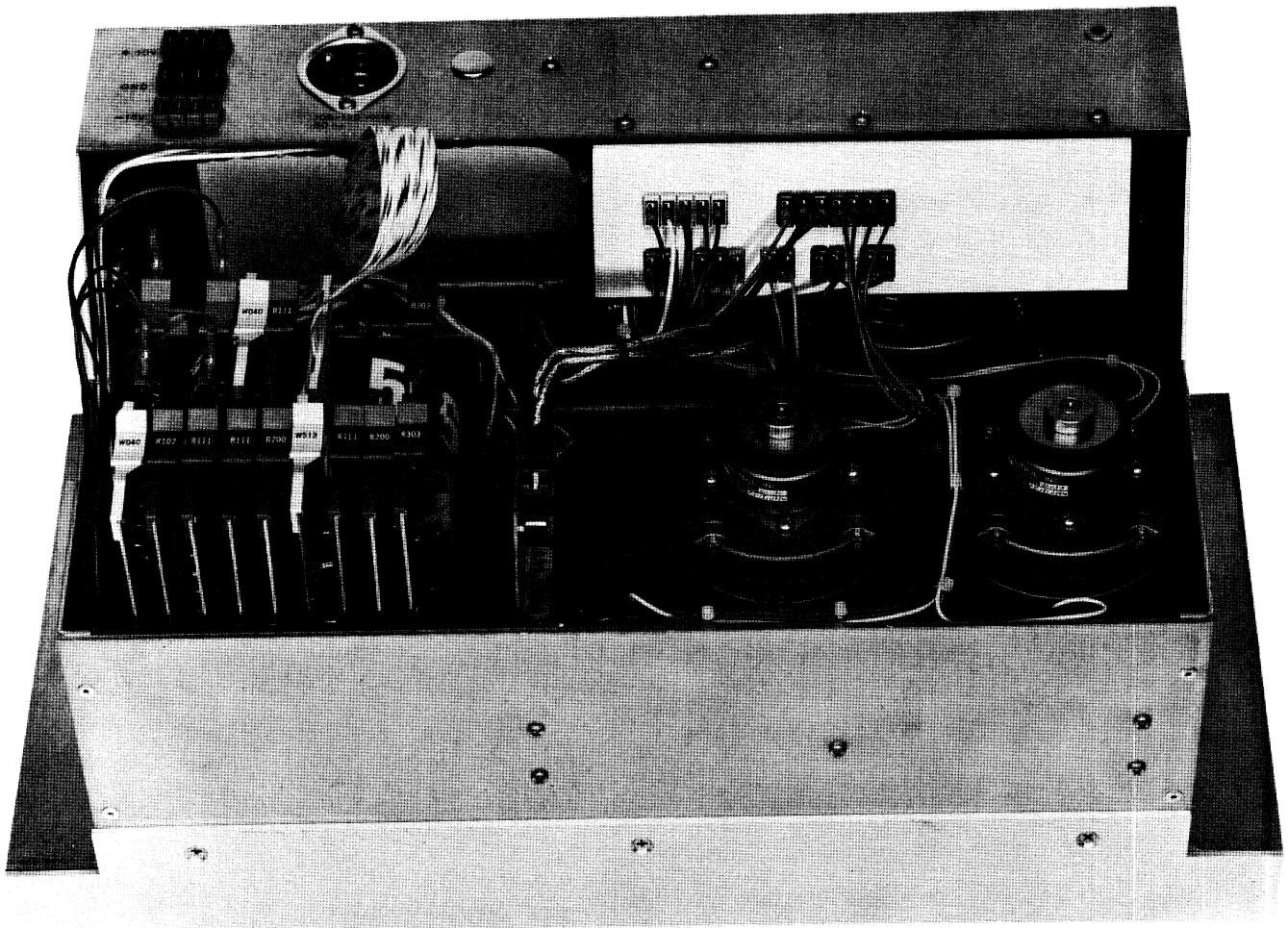

Figure 1-4 Type TU55 DECTape Transport, Rear View

Signal connections to and from the DECTape control system are made through 18-pin and 36-pin FLIP CHIP cable terminators that plug directly into the module mounting panel on the rear panel (Figure 1-4). Cable locations in this mounting panel are shown in Figure 1-5 with respect to the other installed modules. The command cable terminator is a Type W023 18-Pin Connector for the logic signals governing selection and tape motion. The head signal connector is a double-size Type W032 36-Bit Connector for shielded cable. Two sockets at the TU55 logic panel are reserved for the command connector and two for the information connector. The pins for each pair are bussed together. This is done so that TU55s may be grouped. Each TU55 receives its information and commands from one transport in the group through one set of connectors and sends these to the next transport through another set of connectors.

The writing current is 210 ma. Playback peak-to-peak channel voltage is between 10 and 12 mv when the tape is up to speed.

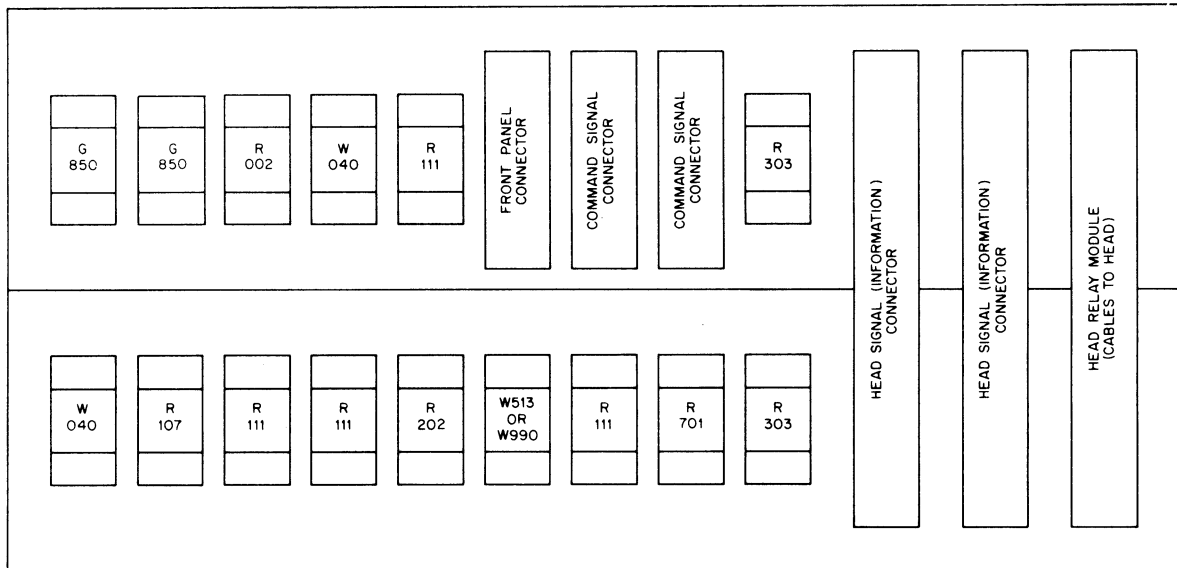

Figure 1-5 TU55 Interface Connections

Command signal levels from the DECTape control to the TU55 Transport are either ground or $-3v$. (Equivalent signals to a 555 Transport are either -3 or $-15v$.) For existing systems with a control system for the 555 Transport, exchanging a single FLIP CHIP module (a W513 Level Amplifier when the TU55 Transport is connected to a control designed to drive relay Transport 555; otherwise a W990 Blank Module) allows the TU55 to accept command signals of either type.

The reel brakes and the head relay are energized by $-15v$ through special solenoid driver circuits; the motors are controlled by silicon controlled rectifier (SCR) circuits that phase-switch the 110 vac line power.

The TU55 uses twelve types of FLIP CHIP logic modules (connectors excluded) as follows:

2	W040 Solenoid Driver	2	R202 Dual Flip-Flop
1	W513 Level Amplifier/W990 Level Amplifier	1	R303 Integrating Delay
1	R107 Inverter	2	G850 SCR Motor Driver
4	R111 Diode Gate	1	G851 Relay Module
1	R303 Integrating One-Shot	3	W023 Indicator Amplifier
1	R002 Diode Network	1	W701 Input Network

All modules are mounted on a dip-soldered epoxy board with 18 gold-plated contacts at one end (36 on double-height modules) for connection to the mounting panel receptacle, and a plastic handle bearing the type number at the other end. Three contacts on each module are reserved for supply voltages: A and B supply the $+10$ and $-15v$ standard power levels; C is the ground.

1.6 TU55 PERFORMANCE CHARACTERISTICS

A summary of the characteristics of the TU55 equipment is given in table 1-1.

TABLE 1-1 SUMMARY OF EQUIPMENT CHARACTERISTICS
FOR THE TU55 DECTAPE TRANSPORT

<u>General</u>	
Overall Size	10-1/2 in. high, 19-1/2 in. wide, 9-3/4 in. deep
Mounting	Standard 19-in. rack. Four #10-32 screws mount chassis track assembly which holds transport. Chassis can be extended 16-3/4 in. beyond mounting surface for maintenance
Power Requirements	-15 vdc, 1.0 amp maximum +10 vdc, 50 ma maximum 115 vac \pm 10%, 1.0 amp idle, 2.0 amp maximum current (60- and 50-cycle models)
Connectors	Commands: two 18-terminal FLIP CHIP female connectors Information: two 36-terminal FLIP CHIP female connectors
Cooling	Internally mounted fan
Operating Temperature	50 to 110°F ambient
Humidity	10 to 90% relative humidity
<p>NOTE: The manufacturer of the magnetic tape for DECTape recommends 40 to 60% relative humidity and 60 to 80°F as acceptable for operating environment.</p>	
<u>Tape Characteristics</u>	
Capacity	260 ft of 3/4 in., 1 mil thick Mylar sandwich tape
Reel Diameter	2-3/4 in. empty reel, 3-3/4 in. for 260 ft of tape
Reel Diameter Ratio	Approx. 1:4 (maximum to minimum)

TABLE 1-1 SUMMARY OF EQUIPMENT CHARACTERISTICS
FOR THE TU55 DECTAPE TRANSPORT (continued)

Tape Characteristics (continued)

Tape Handling	Direct drive hubs and specially designed guides which float the tape over the head hydrodynamically. No capstans or pinch rollers are used.
Speed	93 ±12 ips
Density	350 ±55 bits per inch
Information Capacity	2.7 × 10 ⁶ bits per reel assembled into computer-length words by external DECTape control
Tape Motion	Bidirectional

Drive Characteristics

Times given are for 90% full speed.

Start Time	≤150 msec
Stop Time	≤150 msec
Turn Around Time	≤250 msec

Input Signals to Transport from Control

Commands*	FORWARD	} (ground level assertion, normally complementary levels)
	REVERSE	
	GO	} (ground level assertion, normally complementary levels)
	STOP	
	ALL HALT	(negative level assertion used to stop transport when computer halts)
Unit Select*	SELECT 1 through SELECT 8 (the selected line will be at ground)	

Output Signal from Transport to Control

Control	WRITE ENABLE (standard DEC ground level assertion)
---------	--

*Valid only when the control is operating the solid-state Transport TU55. When relay type transport (Type 555) signals are received a conversion is made to DEC standard levels by the W513 Level Amplifier which converts the -3v level to ground and the floating input to -3v.

CHAPTER 2 THEORY OF OPERATION

2.1 BLOCK DIAGRAM ANALYSIS

The TU55 logic is shown in the functional block diagram of figure 2-1. All front panel controls and indicators are shown within the blocks representing the associated logic. The functions of these controls and indicators are summarized in table 3-1. Diamonds indicate the direction of signal flow between blocks; an open diamond represents a signal effective (asserted) at ground; a closed diamond represents a signal asserted at $-3v$. All interface signals are received from or transmitted to an external DECtape control system. One of the two connectors at the left of figure 2-1 serves as a command and information signal bus to other TU55s.

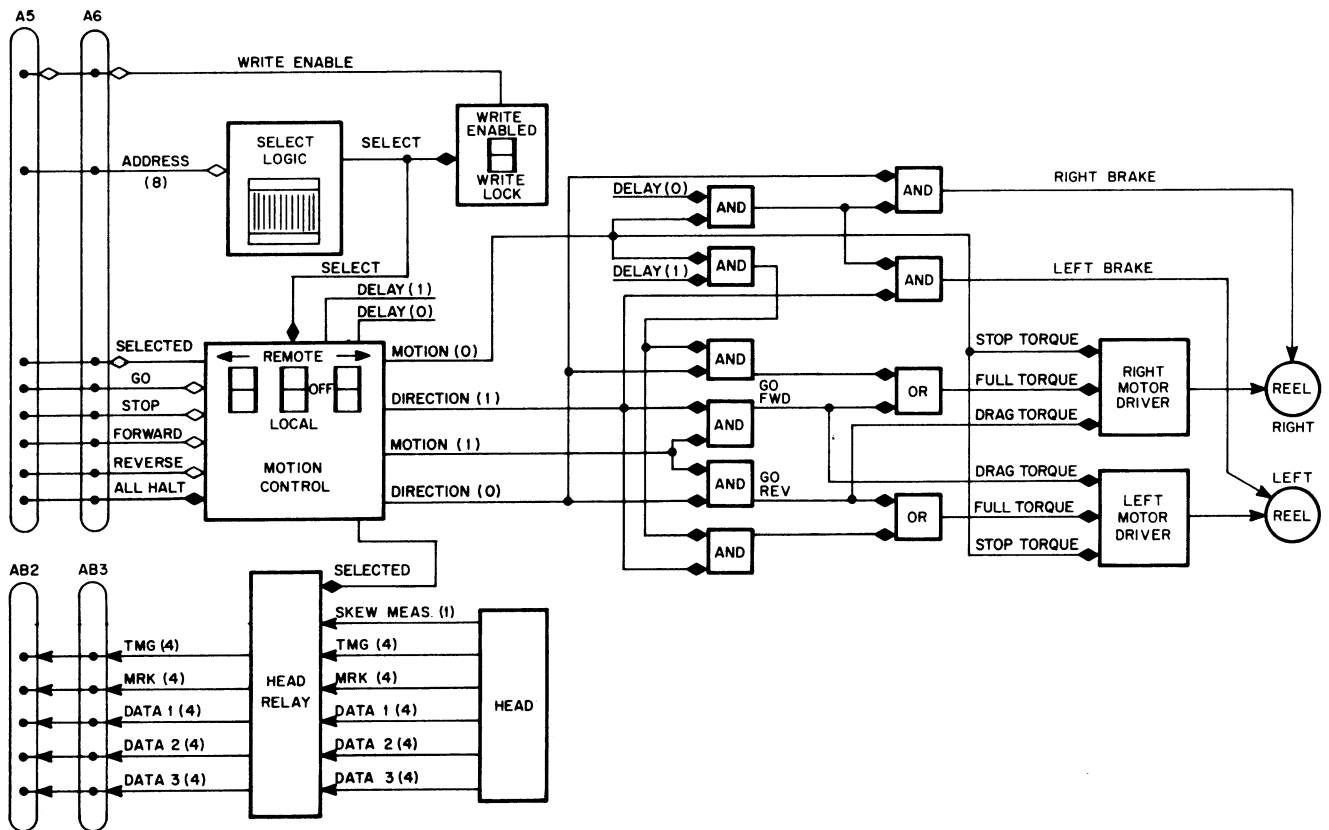

NOTE: An arrow signifies a nonstandard DEC signal, such as motor voltage, head playback, brake voltage, etc.

In the motion control block the arrow above a switch means that pressing this switch results in tape movement in the indicated direction when the middle switch is in the LOCAL position.

Figure 2-1 DECtape Transport TU55 Block Diagram

The SELECTOR LOGIC block in figure 2-1 includes the front panel thumbwheel selector shown in figure 1-1. This selector has nine positions (designated 1 through 8 and OFF LINE) for selecting one of eight select lines which are the outputs of a binary-coded-decimal decoder in the external DEC-tape control system. During addressing, only one of the eight input select lines is at the asserted ground. In remote operation, the SELECT output is asserted negative whenever the thumbwheel setting corresponds to the asserted address line from the DECtape control system.

Writing is possible on a selected drive only when that drive furnishes control with a WRITE ENABLE signal at ground. A selected TU55 furnishes such a signal when the WRITE ENABLE switch in figure 2-1 is on. When this switch is set to WRITE LOCK, the output line is negative and writing cannot take place. If the control is commanded to perform a write function when WRITE LOCK is selected, it displays a selection error flag to notify the program of the mistake.

The five motion commands from the external DECtape control system are shown entering at the left center. The ALL HALT signal is asserted negative by the external control whenever the computer program execution is halted either by the program or by the operator. When the program is halted, the computer cannot issue commands to peripheral equipment. The ALL HALT signal stops those transports that were in motion at the time of the ALL HALT command, thus preventing a complete run-off of the tape.

The other four commands, GO, STOP, FORWARD, and REVERSE, are asserted at ground by the external control in response to computer program commands. In current DECtape controls, GO and STOP are complementary levels. In the following discussion, the GO, STOP, FORWARD, and REVERSE lines referred to are at the output of the signal interface module (B07).

Tape motion begins at a selected TU55 when the GO line is asserted (STOP must be held false throughout the desired interval of tape motion). Motion stops whenever the STOP line is asserted while the GO line is simultaneously held false.

The same conditions as above apply to the FORWARD and REVERSE lines. For a selected transport which is set to REMOTE, asserting the FORWARD line (while holding the REVERSE line false) causes all subsequent remote GO commands to move tape forward. Similarly, asserting the REVERSE line (while holding the FORWARD line false) selects the reverse direction. In LOCAL operation, the reverse and forward tape-motion switches override the last REMOTE direction command so that the tape always moves in the direction of the arrow above the switch (see figure 2-1).

Current DECtape controls generate the GO/STOP and the FORWARD/REVERSE signals as complementary levels. Forward tape motion, for example, is commanded by assertion levels on GO and FORWARD accompanied by false levels on STOP and REVERSE.

When forward motion is commanded either locally or remotely, the motion control logic asserts the FWD output negative. This signal releases both brakes and applies full clockwise torque to the right

motor and partial counterclockwise torque to the left motor. As a result the tape moves from the left reel across the head onto the right reel. The REV line (asserted negative in response to the REVERSE motion command) applies full torque to the left motor, partial torque to the right motor, and simultaneously releases both brakes. Tape motion, therefore, is from right to left. At the end of either command, the STOP line is asserted negative and triggers the stop delay (about 100 msec). For the duration of the delay, full torque is applied to the trailing motor and stop torque is applied to the leading motor (see section 3.3). Thus, for the duration of the delay after the STOP command has been issued, the motor torques are reversed causing tape movement also to be reversed. This time, however, is very short and when the delay times out, the motors come to zero speed while changing their rotation from one direction to the other. After the STOP DELAY times out, the tape becomes motionless and partial torque is applied to both reels to take up the tape slack and the brake is applied to the motor shaft which was trailing during the previous motion. The effect of the delay is nullified if a new motion command is given before the end of the 1-sec interval. Then, the torque signals to the left and right motor drives are immediately reestablished according to the new motion command. The delay starts again at the leading edge of each STOP signal regardless of the frequency of its occurrence; i.e., no recovery time is inherent in this type of delay.

An illustration of the tape head is shown in figure 2-2. Every channel consists of two tracks associated with their coils. When writing, the current flows from ground (center tap) through one of the coils (to either + or - terminal) to saturate the tape in one direction and through the other coil to saturate the tape in the other direction. The coils for the two tracks are wired in series and are brought out as four lines: ground, +, -, and the shield. Within the head relay module, the +, -, and ground lines (center taps) for a channel are switched by one of five 3-pole, normally open reed relays. Shields are not switched, but are through-connected from the head to the interface connectors. A separate line from the timing channel (also shown in figure 2-2) is brought out to allow measurements of head skew (or the head perpendicularity). This line is used only for test purposes (and not by the external control). The single head-ground line is used to ground the head case.

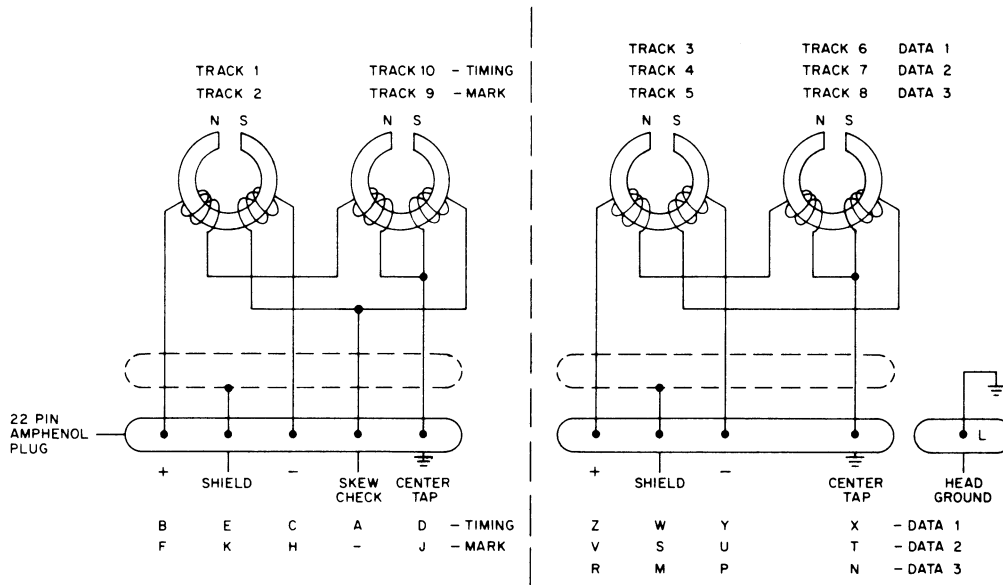

Figure 2-2 Head Connections

2.2 DETAILED DESCRIPTIONS

This section describes, in detail, the flow of information and control through each of the functional elements of the TU55 control unit. The discussion is limited to describing the various modules as logical operators. Detailed descriptions of individual circuits are given in section 2.3, Module Descriptions.

The basis for the discussion in the remainder of this section is the block schematic in DEC drawing BS-D-TU55-0-2. This drawing is subdivided into zones bounded by horizontal section A through D and vertical section 1 through 8. Circuit locations are referenced by a letter-numeral combination. For other drawing symbology, refer to the introductory paragraphs of chapter 5.

2.2.1 Interface

All interface signals received or transmitted by the tape motion control circuits are transferred between the TU55 and the external DECtape control system. Interface signals for the tape-motion control logic consist of: eight unit select input lines, five command input lines, and selected write enable output control lines. Bus connections for these signals from the DECtape control system to the TU55 are made by plugging a FLIP CHIP cable connector into module receptacles (A5 or A6). These signals together with the power lines and the information lines (to be described under Read/Write Head Circuits) constitute the interface for the entire TU55.

2.2.2 Unit Select Lines

The eight unit select lines, numbered 1 through 8, are the outputs of a binary-coded-decimal decoder in the DECTape control and are supplied to the TU55 for application to the unit selector switch S5 (A7, A8). This manually operated switch establishes the programmed address of the TU55, to allow the TU55 to be addressed by the computer program. The unit select lines are connected directly to the corresponding numbered position contacts of the selector switch. The switch wiper arm is connected to input terminal R of the module B07 (C8), thus providing the SELECT command as an output at terminal B07. Module B07 is either a Type W513 Level Amplifier or a Type W990 Blank Module with appropriate jumpers, depending upon the type of input signals. As previously explained, when the input levels are -3v and ground (i.e., the control has been designed specifically to drive the solid-state drive), the W990 Blank Module is used. When an older type control is used (such as 550, 551, or 552) the W513 Level Amplifier is used instead to convert relay driving levels to DEC standard levels. The same applies also to the command line level.

2.2.3 Command Lines

The four major command lines: GO, STOP, FWD, and REV set or clear the MOTION or DIRECTION flip-flops (C7, C6) based upon programmed commands from the computer.

The ALL HALT command level is generated in the control logic of the computer and occurs when the program is halted. This negative level for assertion clears the MOTION flip-flop (C4) to the motion(0) state to stop motion of the transport when the computer program halts. Obviously when the computer program is halted, the computer cannot issue commands to peripheral equipment, and so this action is taken to prevent indefinite running of the transport and to prevent the tape from running off the reel. However, to enable the transport to run under local (or manual) mode, the ALL HALT level is ANDed with the remote level (C4).

2.2.4 WRITE ENABLE Signal

The TU55 generates the ground level WRITE ENABLE signal for routing to the DECTape control from terminal board A5, pin L. To assert this level the WRITE ENABLE/WRITE LOCK switch S3 (A6) must be in the WRITE ENABLE (up) position. This position enables diode gate VUT of module B11 (B6) to generate the WRITE ENABLE signal, and causes the lighting of the WRITE ENABLE indicator on the front panel.

For the older type controls, the W513 Level Amplifier circuit serves as a protection diode for the R107 (B11) Inverter.

2.2.5 Interface Connections

Information lines are brought to the read/write head from the DECTape control system where they are bussed together for connection to other transports. Connections to this bus from an individual TU55 are made by cable connections of module connectors (A4 and B4). These connections are wired to the Type G851 Relay Module (A4, B4) for connection to the read/write head when the relay is operated by the (SELECT) signal amplified by solenoid driver ER of the Type W040 Module (B4).

2.2.6 Read/Write Head

A type G851 Relay Module (A4, B4) establishes connection to the read/write head from the information bus lines of the DECTape control system. This module consists of 5 x 3 single-pole, normally open contacts which are closed when the relay is energized. The relay is energized when the TU55 is selected, thus connecting the read/write head channel coils to the control.

2.2.7 Tape Motion Control

Tape movement and direction of movement are controlled by two Type R202 Flip-Flops; namely, stop/go MOTION flip-flop (C6) and a reverse/forward DIRECTION flip-flop (C7). The flip-flops are set or cleared by command signals originating in the DECTape control system or in the reverse tape-motion and forward tape-motion switches on the front panel (see Figure 1-1).

2.2.8 Remote or Programmed Control

The four major commands that originate in the DECTape control system are GO, STOP, FORWARD, and REVERSE. Type R111 Diode Gates (B4, B5, B6) NAND-and combine these commands with the SELECT level within the TU55. The output of these gates is used to set and clear the MOTION and DIRECTION flip-flops. Therefore, motion and direction are controlled only in the selected transport. The TU55 receives these four major commands as direct connections from the DECTape control system. The eight unit select lines, designated 1 through 8, (B8) are connected to appropriate positions of the unit selector switch (A7, A8). The transport is selected when the selected line coincides with the position of the unit selector switch. The negative SELECT level is conditioned by LOCAL and SELECT ground levels (B7) if the transport is switched to the local mode. Then computer-control selection of the transport is not affected.

The magnitude of the load on the address line is examined by the external control during selection to determine whether more than one DECTape transport is being addressed.

2.2.9 Local (Manual) Control

Switches on the front panel of the TU55 provide for manual control of the tape motion. The shift in control from remote to local is performed through the REMOTE/OFF/LOCAL switch S2A (A6). With the switch on LOCAL, the selected level (C7) is forced to ground potential thus inhibiting the external command NAND gates (R111s). Inhibiting these gates prevents commands from the DECTape control system from affecting the state of either the MOTION or DIRECTION flip-flops and thus prevents interference with manual control. With switch S2 on LOCAL, +10v is supplied to both the REVERSE S4 (A5) and FORWARD S1 (A7) switches. This condition permits the switch operation to establish the appropriate state of both the MOTION and DIRECTION flip-flops when pressed. Switches S1 and S4 are of the momentary contact type which return to a reset position when released. When the REVERSE switch is pressed, the MOTION flip-flop is set to the motion(1) state and the DIRECTION flip-flop is set to the direction(0) state by grounding the appropriate output connection terminals of the flip-flops. The grounding of the flip-flop outputs is done via the outputs of the W701 Switch Filter, generally used to interface switch action to the logic (refer to the circuit description). This module is used both to filter out switch contact bouncing and to load the same contact with some current from a sufficiently high potential to positively bridge across any insulating film that might be formed over the switch contacts, thus assuring an electrical contact when the switch is pressed.

Under these conditions the tape moves in reverse. When the FORWARD switch is pressed, the MOTION flip-flop is set to motion(1) and the DIRECTION flip-flop is set to direction(1), moving the tape forward. Release of either the REVERSE or FORWARD switch clears the MOTION flip-flop, thus stopping tape motion. Therefore, tape motion under manual control occurs only as long as the REVERSE or FORWARD switch is held down physically. Inter-wiring between the REVERSE and FORWARD switches provides a protection feature, so that if both switches are pressed simultaneously, the FORWARD direction will prevail.

2.2.10 Motor Control

The two motors which move the tape past the read/write head are operated by ac power which is controlled separately for each motor by an SCR switch on a Type G850 SCR Motor Control Module (D4, C4). These SCR circuits, in turn, are controlled by combinations of the states of both the MOTION and DIRECTION flip-flops. A brake on the shaft of each motor is also individually controlled by combinations of the state of these control flip-flops (C7, C6). The states of the control flip-flops are decoded by R111 NAND gates which control the SCR circuits, and by Type W040 Solenoid Driver Modules (D4, C4) which control the brakes. Table 2-1 indicates the assertion levels (1) which operate the motors and brakes; or indicates the nonassertion levels (0) which do not operate these devices for all combinations of control flip-flop conditions.

Table 2-1 also presents the three states of motor and brake operation when the tape is running in either the forward or reverse direction.

The functions of the Type G850 SCR Motor Driver Modules (D4, C4) are as follows: with a negative assertion level at terminal H, the motor is driven at full torque; with a negative assertion level at terminal F, the motor is driven with enough drag torque to take up slack in the tape when the motor functions as a trailing motor; with a negative assertion level at terminal E, the motor has just enough torque to take up slack in the STOP condition.

When the tape is running in the forward direction, full torque is applied to the right motor and drag torque is applied to the left motor. When the STOP command is given, full torque is removed from the right motor and applied to the left motor for the duration of the delay of the Type R303 One Shot Module (D7), and stop torque is applied to both motors. At the end of the one-shot delay, which is approximately 100 msec, full torque is removed from the left motor, the brake is applied to the left motor, and stop torque remains on both motors to take up the slack in the tape until the next command is received. (Of course the stop torque applied to that motor which has the brake on is doing nothing).

A similar sequence of events occurs when tape movement is in the reverse direction and the STOP command is received. Hence, after a STOP command occurs, the brake is applied only to the shaft of the trailing motor, positively stopping the motor shaft to which it is applied. When the tape is at rest (which is most of the time), the stop torque applied to the motor to take up tape slack is minimum to avoid excessive heating of the system.

The logical negative levels applied to pins E, F, and H of the G850 SCR Motor Control are ANDed with the negative BRAKE ENABLE level (C4, D4). This level is negative (B6) only when the REMOTE/OFF/LOCAL switch is on either REMOTE or LOCAL. When the switch is in the OFF position, the level is at ground potential and disables both the G850 SCR Motor Control motor circuits and the brakes (dc +10 and -15v are still present). This switch position is used when a tape reel is to be mounted or dismantled and is also recommended when a particular drive is not being used. (On the older Type TU55 Transports the same 3-position switch was used to interrupt the ac power to the transport and the BRAKE ENABLE level did not condition the G850 circuit. Thus the power itself was interrupted instead of logically controlling the G850 Motor Control.)

2.2.11 Transport Selected Signal

The negative SELECT level enables another Relay Driver Type W040 (C7) whose output is sent through a resistor to interface pin K on A5/A6 modules from where it is sent to the control. The control can use this line to sense whether more than one transport is being selected at one time. Usually an analog type circuit uses the fact that current could go through the resistor when the relay (transport) is selected, and, if more than one (or no) transport is selected, causes an error signal. This feature is not needed when the transport is connected to a 550, 551, or 552 Control.

Transformer T1 (C3) synchronizes the SCR firing with the 60-cycle waveform of the primary power. The Thyrector connected across the primary of this transformer protects the diode bridge rectifiers in the Type G850 Modules.

Table 2-1 Motor and Brake Operation Truth Table

Operation Mode		Control Element			Left Motor			Left Brake	Right Motor			Right Brake
		STATES			Pin H	Pin F	Pin E		Pin H	Pin F	Pin E	
		Direction	Motion	Delay	Full Torque	Drag Torque	Stop Torque		Full Torque	Drag Torque	Stop Torque	
Reverse	Running	0	1	0	1	0	0	Off	0	1	0	Off
	Stopping	0	0	1	0	0	1	Off	1	0	1	Off
	Stopped	0	0	0	0	0	1	Off	0	0	1	On
Forward	Running	1	1	0	0	1	0	Off	1	0	0	Off
	Stopping	1	0	1	1	0	1	Off	0	0	1	Off
	Stopped	1	0	0	0	0	1	On	0	0	1	Off

2.3 MODULE DESCRIPTIONS

Complete circuit information for the FLIP CHIP modules in the Type TU55 DECTape Transport is contained in the replacement schematic engineering drawings (see chapter 5). A list of the FLIP CHIP modules used in the TU55 is included in engineering drawing PL-TU55-0-5, Module count list. Their locations are shown on drawing MU-TU55-0-5. These modules are described in DEC Digital FLIP CHIP Module Catalog, C-105, and in appropriate New Module News Bulletins. Descriptions of non-catalog modules are contained in the following subsections.

2.3.1 Type R303 Integrating One Shot (Delay)

This module includes a zero-recovery-time multivibrator and complementary output buffers (see Figure 2-3 and DEC drawing RS-B-R303). It responds to inputs signals (up to 2 mc) which may occur at any time either within or outside the delay interval. Successive inputs above a preset frequency can postpone the delay indefinitely.

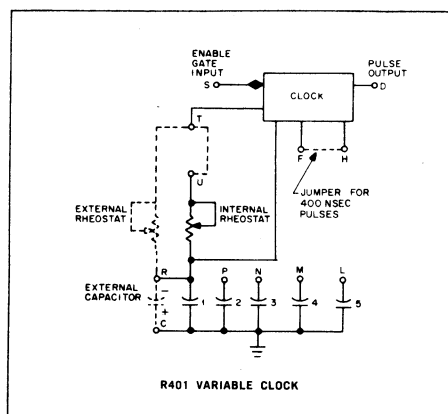

Figure 2-3 Diagram of R303 Integrating One-Shot

2.3.2 Type W513 Level Amplifier

This module contains six identical level amplifier circuits (see engineering drawing RS-B-W513). The input levels are received from DEC relay or solenoid driver circuits having outputs which are between -2 and $-3v$ when the driver is "on" (1) and are floating when it is "off" (0). An input current exceeding 1.2 ma to the level amplifier makes the input potential more positive than $-3.5v$ and asserts the output at ground. When the input current is cut off, the input potential returns to approximately $-5v$ and the output becomes $-3v$. Since all circuits are identical, the first circuit in the replacement schematic (input at D and output at E) is described.

The circuit is quiescent when no input current is flowing into D. Diodes D1 and D2 clamp input return R1 at about $-5v$. The drop across D1 maintains Q1 cutoff, thus allowing R3 to keep the Q2 base positive and cut off Q2. D4 clamps output E at the Q2 collector to $-3v$.

When the input goes more positive to -2 to $-3v$ it starts supplying current to pin D. It will back bias D1 and turn on Q1. Q2 base current flows through Q1 and R2 so Q2 turns on, bringing E to ground potential. When the input current at D opens, both transistors cut off again and the circuit is quiescent again.

A resistor is tied to pin T. It is used to simulate relay currents such as those existing in the 555 Relay Transport and therefore allows mixing TU55s and 555s in the same system. The current through this resistor is measured by an analog circuit at the control to determine whether one or more transports are being selected and causes an alarm or error signal in case the latter condition happens.

2.3.3 Type G850 SCR Motor Driver

Essentially this module is an SCR switch for the ac voltage supplied to any one of the drive motors of the TU55. The SCR switch is turned on and off twice during each cycle of the ac power. The firing point of the SCR is controlled so that it can occur at almost any point along the sinusoidal waveform of the ac power; thus controlling the amount of energy that is transmitted to the load (the motor), and thus achieving control of motor torque. A simplified schematic diagram of this module is shown in Figure 2-4, a complete schematic in DEC engineering drawing RS-B-G850.

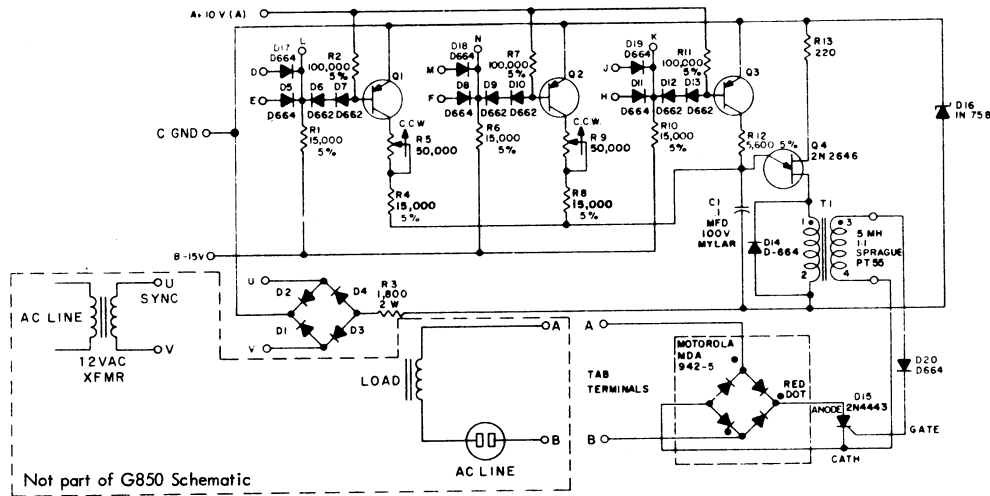

Figure 2-4 Schematic of G850 SCR Motor Driver

The SCR itself (D15), is connected into a diode bridge so that current always passes through it in the same direction (an SCR is not a bilateral device). The firing circuit for the SCR incorporates a unijunction transistor (Q4) and an RC timing network. The capacitor (C1) in this network starts to charge at the beginning of each half cycle of the ac voltage. When the voltage developed across the capacitor reaches the firing point of Q4, conduction starts and current flows in the primary of a coupling transformer (T1). Voltage induced in the secondary of T1 controls the firing of the SCR and causes the motor to operate.

Three input timing circuits determine the trigger timing of the SCR. A -3V level applied to the two-diode input of these circuits cause the SCR to trigger at a fixed rate or a variable rate determined by the setting of potentiometers R5 and R9. The fixed input circuit (Q3) triggers the SCR near the beginning of the sinusoidal wave to produce maximum torque.

A low voltage ac input is supplied to terminals U and V from the secondary at transformer T1 of the TU55 logic (not T1 of the module). This input voltage is full wave rectified and is clipped by a

Zener diode, but is not filtered. It provides the potential toward which the timing circuit attempts to charge. Being a stepped down version of the primary ac power which operates the drive motors, this voltage synchronizes the firing of the SCR to the line frequency. Since the voltage at the end of each half cycle is zero, the RC network must start charging at the end of each half cycle. Therefore, this pulsating voltage causes the SCR to fire each half cycle at a point in time measured from the zero voltage point.

CAUTION

Be very careful when handling this circuit or probing it for measurement purposes since it contains 115v ac. A short circuit caused by a probe could produce a high current. Do not tamper with this module without first disconnecting power from the back terminal.

CHAPTER 3 OPERATION

3.1 INTRODUCTION

As stated in chapter 1, the TU55 can be operated in either a local (manual) or a remote (auto-programmed) mode. Local operation is accomplished by use of the controls and indicators on the front panel of the equipment. Remote operation is effected through programmed commands produced by the stored program of the computer. The following paragraphs contain information applicable to both modes of operation.

3.2 CONTROLS AND INDICATORS

The functions of the controls and indicators on the control panel in figure 1-1 are summarized in table 3-1. Additional information of the action initiated by the controls is given in the following paragraph.

3.2.1 Operating Notes

When the REMOTE/OFF/LOCAL switch is in the OFF position, the REMOTE indicator does not light but the TU55 logic still responds to selection, control, and command signals from external control. Consequently the external control may select and attempt to read or write tape but no tape motion takes place. In all normal modes, this condition idles both the DECTape control system and TU55 because no timing channel signal is made available from a motionless tape. When the system is commanded to write on the timing and mark channels, the timing pulses are generated within the external control permitting the control to operate as if tape motion were available.

3.3 LOADING TAPE

To mount a reel of DECTape on the TU55 after energizing the equipment, proceed as follows (see figure 1-1 and table 2-1):

To load tape set the REMOTE/OFF/LOCAL switch to the OFF position. This releases the brake and inhibits the operation of the G850 SCR Motor Driver circuits. Then the hubs are free to be loaded or unloaded with tape reels. If a new reel is to be mounted, unreel about a foot of tape from it over the guides and read/write head and wind the tape one or two revolutions onto the right reel. Turn the switch to either LOCAL or REMOTE as is desired for the next operation.

TABLE 3-1 FUNCTIONS OF CONTROLS AND INDICATORS

Control or Indicator	Function
Reverse tape-motion switch (designated in figure 1-1 by arrow pointing to the left)	Provides reverse tape motion (i.e., from right to left) only if REMOTE/OFF/LOCAL switch is on LOCAL.
WRITE ENABLED/WRITE LOCK switch	
WRITE ENABLED	Permits external DECtape control system to write information on the TU55.
WRITE LOCK	Prevents the above writing. If external DECtape control system is commanded to write on tape during the WRITE LOCK setting, the control initiates a selection error flag to notify the program. The WRITE LOCK setting, however, does not prevent tape motion when the REMOTE/OFF/LOCAL switch is on REMOTE.
WRITE ENABLED indicator	Lights when WRITE ENABLE/WRITE lock switch is in the WRITE ENABLE position.
Address selector (or unit selector)	
1	When set to one of the numerals (designating addresses) and REMOTE/OFF/LOCAL switch is on REMOTE or OFF, the transport is selected when the line indicated by the switch wiper corresponds to the computer selection through the DECtape control. Then the transport responds to command signals from external control and can assert a write enabling signal to the control. In addition, all head channels are connected through the head relay to control bus information lines.
2	
3	
4	
5	
6	
7	
8	
OFF LINE	Prevents external DEC control system from selecting the TU55.
REMOTE/OFF/LOCAL switch	
REMOTE	Permits TU55 to accept command and control signals from the external DECtape control system; also enables head relay logic to connect all head channels to control bus information lines as soon as appropriate transport is selected.
OFF	Inhibits operation of the G850 SCR Motor Control Modules and releases the brakes. Power for the logic components comes from power supplies associated with the external control, and therefore the OFF position does not turn off the +10 and -15v power. The OFF position is used when loading new tape reels since it releases the motor hubs. The transport should be set to OFF when not in use.

TABLE 3-1 FUNCTIONS OF CONTROLS AND INDICATORS (continued)

Control or Indicator	Function
LOCAL	Permits forward and reverse tape-motion switch to provide tape motion in direction of arrow. Transport cannot be selected.
REMOTE indicator	Lights only when transport is selected by the control.
Forward tape-motion switch (designated in figure 1-1 by arrow pointing to the right)	Provides for motion in the forward direction (i.e., from left to right), but only when REMOTE/OFF/LOCAL switch is on LOCAL. If both reverse and forward tape-motion switches are pressed simultaneously, the forward motion takes place.

CHAPTER 4
MAINTENANCE

4.1 EQUIPMENT REQUIRED

Maintenance activities servicing TU55 DECtape Transports require the equipment listed in table 4-1, or the equivalent; plus standard hand tools, cleansers, test cables, probes, etc.

TABLE 4-1 RECOMMENDED MAINTENANCE EQUIPMENT

Equipment	Manufacturer	Model
Multimeter	Triplett or Simpson	630-MA or 260
Oscilloscope *	Tektronix	Series 540 or 580 with Type CA differential preamplifier
FLIP CHIP module extender	DEC	W980
Small thin-bladed screwdriver		
Phillips-head screwdrivers		All four standard sizes
Allen-wrench set		No. 667

* Head gain and head skew tests require a dual-beam oscilloscope such as Tektronix Type 550 or 551 with a high-gain differential preamplifier for each beam channel, such as Tektronix Type D. However, these tests are seldom necessary in the field.

4.2 PREVENTIVE MAINTENANCE

The following weekly and monthly preventive maintenance schedules are recommended to forestall possible failures. Special emphasis is placed on cleanliness of tape handling surfaces because dust and oxide particles contribute to read errors.

4.2.1 Weekly Schedule

- a. Clean entire front panel of tape deck.
- b. Clean both surfaces of tape guides and tape head using an appropriate head cleaner and a soft lint-free cloth.
- c. Check proper operation of motor and reel brakes before loading tape by momentarily pushing forward and reverse tape-motion switches on front panel.

4.2.2 Monthly Schedule

This schedule should be performed on each DECtape once a month when equipment operates on a standard 8-hour shift and more often when daily operation exceeds one shift. Stagger the check-outs on individual transports evenly throughout each month.

- a. Clean the exterior and interior of the cabinet using a vacuum cleaner and clean cloths moistened, if necessary, in nonflammable solvent.
- b. Clean air filters at the bottom of bay using procedure given in PM section of maintenance manual for DECtape control system.
- c. Lubricate door hinges, casters, etc., with a light machine oil.
- d. Inspect equipment for completeness and general condition. Repaint scratched or corroded areas.
- e. Make sure each FLIP CHIP module is securely seated in its mounting panel connector.
- f. Run a complete exercise and diagnostic routine for each transport so that both the transport and its associated control are exercised in all possible modes and in both directions. Maintenance programs for this purpose are available from DEC for all computer/control/transport DECtape systems. Applicable programs are listed in the maintenance manual for the DECtape control system. Log all errors to provide a malfunction history as an aid to troubleshooting. If tape is slack or bounces during exercises, perform the adjustment and calibration procedures in the next subsection.
- g. Rotate tapes among all transports and use the read routines of the maintenance programs to be sure that all transports can read tapes generated by other transports. If each transport operated satisfactorily in step f, any malfunctions in this step are probably due to head skew. Head skew can be measured by the procedures given later in the troubleshooting subsection but cannot be adjusted in the field.

4.3 TAPE TENSION AND TRANSPORT STOP ADJUSTMENT

- a. Set the R303 Integrating Delay to about 70 ns. Pin D in A04 of the delay is varied with the aid of the trimpot mounted on the module.

Initiation of the delay is made by pressing momentarily on either the forward or reverse switch when the REMOTE/OFF/LOCAL switch is on LOCAL. No tape reel is needed for this operation.

- b. Mount a tape reel on the transport. Press the forward switch and watch the tape movement. The trailing torque of the left motor should be adjusted on the G850 Module A11 trimpot (as shown in figure 4-1). If the torque is too great it will impede the movement at the tape; and if too little, flapping or loose contact with the read write head will result. The technician who maintains the equipment might develop a "touch" so that by pressing his finger over the tape at the trailing reel he can tell if the tape is too tight or loose, simply by the stiffness of the tape while in motion.
- c. Repeat same procedure for reverse tape movement by pressing reverse switch. This time the pot adjustment is done on module A12.
- d. Press forward switch for a second or two and release it; the tape action while stopping should be smooth. If bouncing occurs, increase the stopping torque until bounce just disappears. This stop torque is maintained when the transport is not operating (which is most of the time) and excessive torque merely results in overheating the motor and hence the whole equipment. Torque adjustment is made on the appropriate pot (figure 4-1) on module A12.
- e. Repeat same procedure when pressing the reverse switch, watching for the stop when tape movement is in reverse. Adjust pot on module A11.

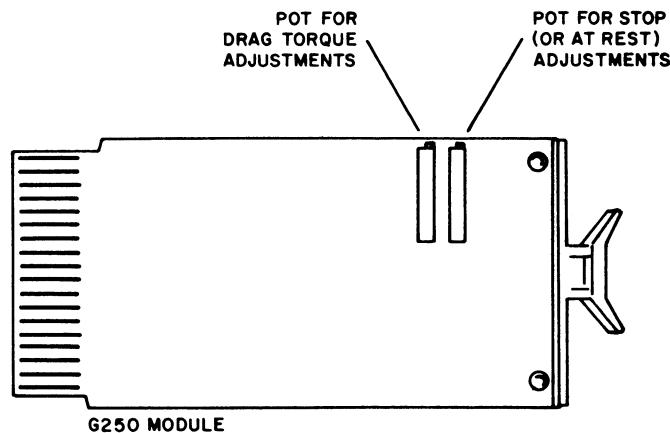

Figure 4-1 Module Adjustment Trimpots

4.4 HEAD OUTPUT CHECK

This check is used to determine whether the read-head is developing the proper read signals. If the read-head performance is not satisfactory, the head should be replaced. No attempt should be

made in the field to repair or even change head position by loosening the brackets that hold it to the plate. Although DEC personnel are authorized to replace heads in the field, the replacement involves realignment and usually requires the return of the transport to DEC, Maynard. The following diagnostic procedure can be performed with any single-channel oscilloscope having a high-gain differential pre-amplifier capable of handling signals in the millivolt range over a bandwidth of 0 to 60 kc, (Tektronix Type D Plug-in Unit).

- a. Mount a DEC certified tape on the TU55 Transport. Move tape manually in a forward direction until approximately one half of the tape is on each reel.
- b. Disconnect the 22-pin Amphenol head connector from rear of Head-Relay Module G851 located at the extreme right of the mounting panel seen from the rear. Attach the two probes of the differential amplifier to pins B and C of this connector and attach the ground clip to D. Set the oscilloscope to sync internal, and set the vertical preamplifier to 5 mv/cm (0.5 mv/cm if an X10 probe is used).

An alternative method is to cause a closure of the information relays by grounding (with the aid of a clip) pin E of the G851 Module at location AB1. This eliminates disconnecting the plug procedure, as outlined above, by making it possible to monitor the same plug points on the wiring panel front. The probes are now attached to pins AF and AH of the same FLIP CHIP socket AB1. The ground clip is attached to pin C.

- c. Move tape forward and reverse using forward tape-motion switch and observe that the read-head waveform is about 10 to 12 mv peak-to-peak.
- d. Repeat step c, attaching the probes to pins F-H, P-R, U-V, and Y-Z. These signals may not look sinusoidal (as they do for pins B-C), but the peak-to-peak amplitude should measure the same as in step c. The same alternative exists here as in step b. The pin pairs to monitor now are: AN-AP, AV-BD, BH-BJ, and BN-BP.

4.5 HEAD-SKEW CHECK

Although the head-skew is not adjustable in the field, the following check should be performed when unusual numbers of read errors are observed on an individual transport engaged in reading tapes generated by several other transports. The procedure requires a dual-beam oscilloscope with two high-gain differential preamplifiers for each scope channel (as outlined in the equipment needed, 4.1).

- a. Write a timing track on a scratch tape using one of the DECtape utility routines.

- b. Rewind tape back onto the left reel. Dismount the left reel from the left hub and mount it on the right and mount the empty reel on the left hub. Thread tape over the head and onto the left reel. Move tape in reverse to fill up the left reel. The tape is now with its oxide facing up away from the head.
- c. Disconnect the 22-pin Amphenol head connector from rear of Head Relay Module G851. This module is located at the extreme right of the mounting panels, seen from the rear.
- d. Connect the two upper-scope channel probes to head connector pins A and C and their ground clips to the chassis. Connect the two lower-scope channel probes to head connector pins A and D and their ground clips to the chassis. Set both channel preamps to A-B (the differential setting).
- e. Move tape forward by using the forward tape-motion switch. Adjust channel gain so that each waveform has the same peak-to-peak voltage. Sync on the upper beam and take a reading of the phase difference between the signal peak at pins A and D (track 10) with respect to the signal peak at pins A and C (track 1). Be sure to record whether the track 10 signal leads or lags the other and the amount. Make all readings as near the center of the tape length as possible. Skew readings greater than 5 μ sec indicate possible incompatibility among transports. Probably the head has become misaligned through physical damage. Then the transport must be returned to DEC, Maynard, for realignment.
- f. Remove all probes, reconnect the Amphenol connector to the rear of the G851 Head Relay Module, and rewind the tape to the original state.

NOTE 1: It is possible here also to use the alternative method of monitoring the channel waveforms (see alternate method, section 4.4b) by energizing the relay at the G851 Module by grounding pin E. By doing so probe clips can be attached to the wiring panel pins at location A1. The pins are D-H for one probe and D-J for the other.

NOTE 2: In some heads (manufacturer, GJM) use pin F instead of pin H on the FLIP CHIP socket. On the Amphenol plug at the back use pin B instead of pin C.

4.6 WRITE ENABLE CIRCUIT CHECK

- a. Set the WRITE ENABLE/WRITE LOCK switch to WRITE position and check that the WRITE ENABLE indicator lights. Also check that a ground level is present at terminals A5L and A6L (C8).

- b. Set the switch to the WRITE LOCK position and check that the WRITE ENABLE indicator is extinguished. Also, check that level at terminals A5L and A6L is $-3v$. Check transmission of this level from terminal A5L to the DECTape control system.

4.7 TROUBLESHOOTING

The forward and reverse tape-motion switches on the front panel of the TU55 are useful in checking the operation of the unit and in assuring that the tape-motion mechanism is working properly. It is suggested that the first step in troubleshooting should be a check of the modular logic circuits.

For this check, the primary ac power cable should be disconnected from the plug at the back of the transport to prevent movement of the tape drive motors. Set the REMOTE/OFF/LOCAL switch to the LOCAL position. Then simulate the commands to GO FORWARD and GO REVERSE by pressing the appropriate switch. When the switch is released, the STOP command is initiated to energize the left motor shaft brake (the brake coil is energized from the $-15v$ supply). Under these conditions, use an oscilloscope or a voltmeter to compare the command signals throughout the logic circuits against those in table 3-1.

This operation is checked by monitoring the terminals of the Type G850 Modules (A11 and A12) and the Type W040 Modules (B12) with an oscilloscope or voltmeter to verify proper signal levels for all operating conditions of the MOTION and DIRECTION flip-flops (B08). Then inspect the motor hubs to check for proper operation of the brakes. This is accomplished by assuring that the proper hub stops when called upon to do so by the command logic (activated by operation of the front panel tape-motion switches).

If the truth table cannot be verified, continue troubleshooting by signal tracing, monitoring the signal levels at different NAND gate inputs and outputs and working back toward the control flip-flops until the cause of the malfunction is found. If the truth table can be verified, restore the primary ac input power, install a reel of tape on the drive mechanism, and repeat the truth table verification procedure for proper tape movement and end stopping. If the malfunction still exists, check the following sources of trouble:

- a. Transformer T1 secondary is not presenting stepped down ac power to terminals U and V of the modules A11 and A12 (the Type G850 SCR Motor Driver Modules).
- b. Type G850 Modules are defective.
- c. Electromechanical system (e.g. reel motor) rather than the control logic.

4.8 RECOMMENDED SPARES

Table 4-2 lists the recommended spare parts for TU55 Transport systems. A R-series module in the TU55 may be replaced by an S-series module with the same number. All items are available at DEC, Maynard, but may be ordered from the other firms listed.

TABLE 4-2 RECOMMENDED SPARE PARTS

Part Number	Part	Manufacturer
G850	SCR motor driver	DEC
G851	Head relay	DEC
R002*	Diode network	DEC
R303**	Integrating one shot	DEC
S107*	Inverter	DEC
S111*	Diode gate	DEC
S202*	Dual flip-flop	DEC
W040	Solenoid driver	DEC
W513***	Level amplifier	DEC
W701	Input network	DEC
MD/B570-0-11-1-A	Rotary selector switch (address selector)	DEC
8132K20 G6V52	Rocker switch (REMOTE/OFF/LOCAL)	Cutler-Hammer
8132K22 G6V52	Rocker switch (WRITE ENABLED/LOCK)	Cutler-Hammer
8137K21 G6V52	Rocker switch (forward and reverse tape-motion) (with off-nonmomentary on circuit)	Cutler-Hammer
7533-7	Capacitor (reel motor), 7 mfd, 300 wvdc	Sangamo
MOT-1	Torque motor, 70-frame, SP spec	Electric Indicator Co. (ELINCO)
BK-0001	Friction brake, FB-181-23 DEC spec	Megatrol

* These modules are contained in the basic PDP-8 or the TC01 DECTape Control, so duplicate spare parts are not required if the TU55 is part of this system configuration.

** This module is contained in the TC01, so a duplicate is not required if the TU55 is used with a TC01 DECTape Control.

*** This module is required only if the TU55 is not used with a TC01 DECTape Control.

CHAPTER 5

ENGINEERING DRAWINGS

5.1 INTRODUCTION

This section contains reduced copies of the engineering drawings, (see Pertinent Documents chapter 1) required for understanding and maintaining the Type TU55 DECtape Transport. These drawings are in addition to the complete set of full-size drawings forwarded with each TU55. Only the full size drawings should be used by maintenance personnel for work on the units. The full-size drawings show variations peculiar to an individual installation.

5.2 CIRCUIT SYMBOLS

The block schematics of DEC equipment are multipurpose drawings that combine signal flow, logical function, circuit type and physical location, wiring, and other pertinent information. Individual circuits are shown in block or semiblock form, using special symbols that define the circuit operation. These symbols are similar to those appearing in the FLIP CHIP Module Catalog but are often simplified. Figure 5-1 illustrates symbols used in DEC engineering drawings.

5.3 LOGIC SIGNAL SYMBOLS

DEC standard logic signal symbols are shown at the input of most circuits to specify the enabling conditions required to produce a desired output. These symbols represent either standard DEC logic levels or standard FLIP CHIP pulses.

5.3.1 Logic Levels

The standard DEC logic level is either at ground (0 to $-0.3v$) or at $-3v$ (-2.5 to $-3.5v$). Logic signals generally have mnemonic names which indicate the condition represented by assertion of the signal. An open diamond (\rightarrow) indicates that the signal is a DEC logic level and that ground represents assertion; a solid diamond (\blacktriangleright) indicates that the signal is also a DEC logic level and that $-3v$ represents assertion. All logic signals applied to the conditioning level inputs of diode-capacitor-diode gates must be present for a minimum of 400 nsec before an input pulse will trigger operation of the gate.

5.3.2 FLIP CHIP Pulses

Two types of pulses, R series and B series, are used in FLIP CHIP circuit operation. The pulse produced by R-series modules starts at $-3v$, goes to ground ($-0.2v$) for 100 nsec, then returns to $-3v$. This pulse is shown in figure 5-2.

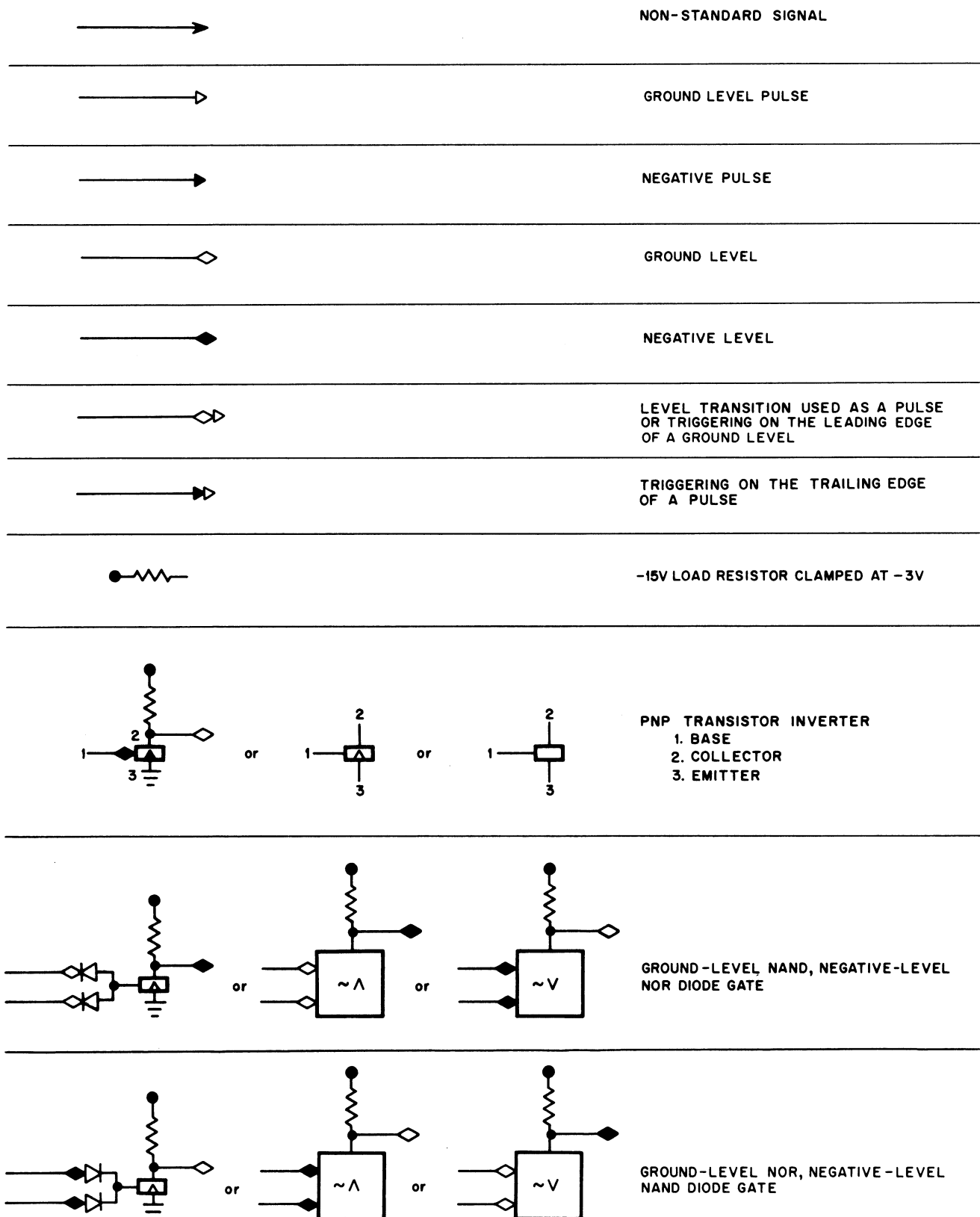
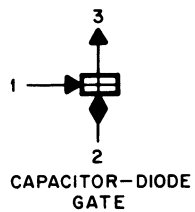
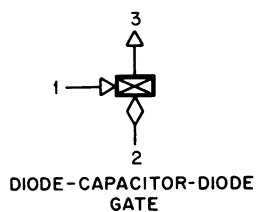
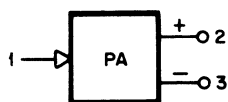

Figure 5-1 DEC Symbols



CAPACITOR-DIODE GATE, POSITIVE OR NEGATIVE INDICATED BY POLARITY OF THE INPUTS.

1. PULSE INPUT
2. CONDITIONING LEVEL INPUT
3. PULSE OUTPUT



PULSE AMPLIFIER

1. PULSE INPUT, POLARITY INDICATED BY INPUT SIGNAL
- 2,3. TRANSFORMER-COUPLED PULSE OUTPUT. EITHER TERMINAL MAY BE GROUNDED

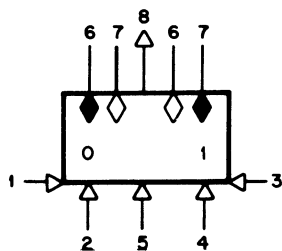

FLIP-FLOP (MOST FLIP-FLOPS HAVE ONLY SOME OF THE FOLLOWING):

1. DIRECT-CLEAR INPUT
2. GATED-CLEAR INPUT
3. DIRECT-SET INPUT
4. GATED-SET INPUT
5. COMPLEMENT INPUT
6. OUTPUT LEVEL, -3V IF 0, 0V IF 1
7. OUTPUT LEVEL, 0V IF 0, -3V IF 1
8. CARRY PULSE OUTPUT, UPON BEING CLEARED

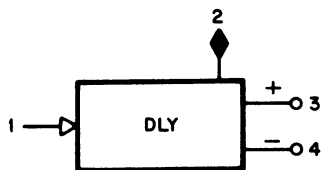

DELAY (ONE-SHOT MULTIVIBRATOR)

1. INPUT PULSE
2. OUTPUT LEVEL, -3V DURING DELAY
- 3,4. TRANSFORMER-COUPLED PULSE OUTPUT. EITHER TERMINAL MAY BE GROUNDED

Figure 5-1 DEC Symbols (continued)

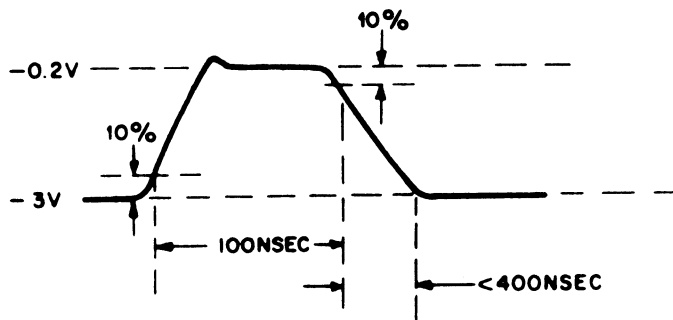

Figure 5-2 FLIP CHIP R-Series Pulse

The B-series negative pulse is 2.5v in amplitude and 40 nsec in width as shown in figure 5-3. If this pulse is applied to the base of an inverter, the inverter output will be a narrow pulse, similar in shape to the R-series standard pulse. The B-series positive pulse, which goes from ground to +2.5v, is the inverse of the B-series negative pulse.

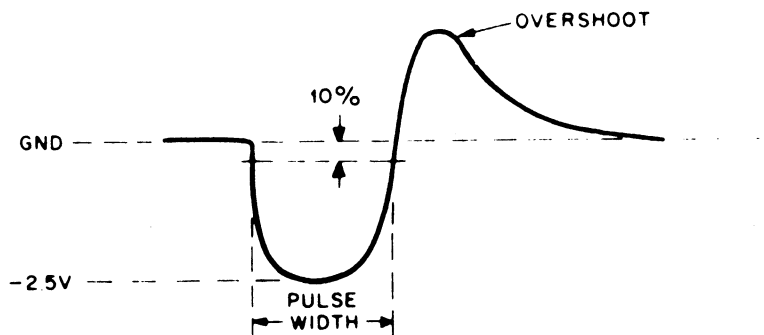

Figure 5-3 FLIP CHIP B-Series Pulse

5.4 SEMICONDUCTOR SUBSTITUTION

Standard EIA components as specified in table 5-1 can replace most DEC semiconductors used in modules of the TU55 DECTape Transport. Exact replacement is recommended for semiconductors not listed.

TABLE 5-1 SEMICONDUCTOR SUBSTITUTION

DEC	EIA	DEC	EIA
D662	1N645	DEC 3638	2N3638
D664	1N3606	DEC 3639, -0	2N3639
DEC 3009	2N3009	DEC 3790	2N3790
DEC 3494	2N3494	MR2066	1N4003

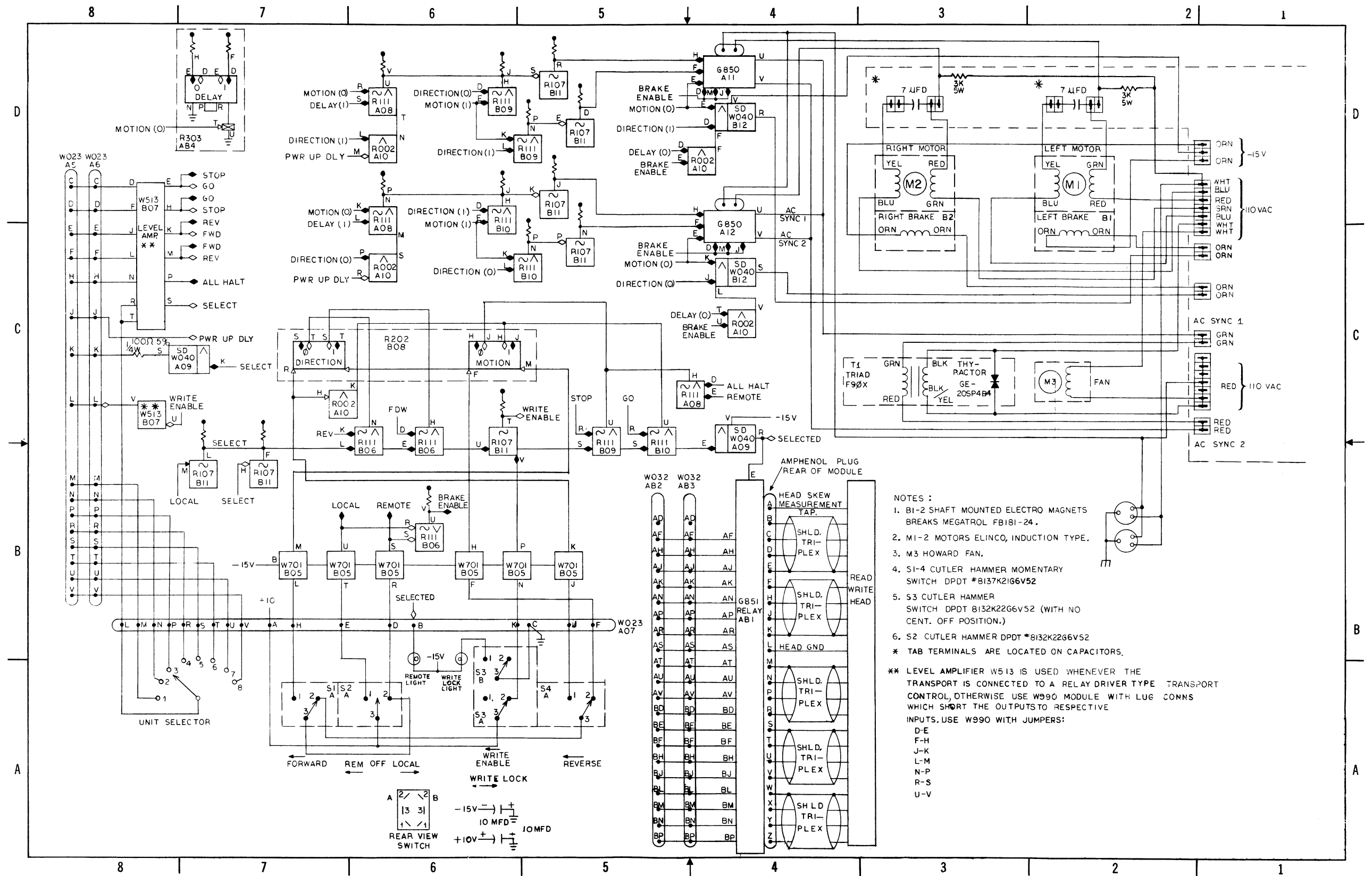

Solid State DECtape Transport BS-D-TU55-0-2, Rev J

	1	2	3	4	5	6	7	8	9	10	11	12
	G851	W032	W032	R303	W023	W023	W023	R111	W040	R002	G850	G850
					CMD* CONN	CMD* CONN		ALL		LEFT BRAKE ENABLE MOTION		
								HALT				
								RIGHT	SEL'D RELAY			
A	READ WRITE HEAD RELAY	* INFO CONN	* INFO CONN	STOP DELAY			SWITCH CONN.	RIGHT MOTOR	LEFT MOTOR DRIVER	LEFT MOTOR	LEFT MOTOR SCR	RIGHT MOTOR SCR
								ENABLE		ENABLE RIGHT MOTOR		
								LEFT MOTOR	SEL BUS DRIVER	ENABLE RIGHT BRAKE ENABLE		
								ENABLE				
					W701	R111	W513	R202	R111	R111	R107	W040
							STOP		LEFT MOTOR ENABLE	RIGHT MOTOR ENABLE	LEFT MOTOR ENABLE	LEFT BRAKE DRIVER
					STOP	REM FWD	GO	MOTION			SEL	
					GO REV		REV.		LEFT MOTOR ENABLE	RIGHT MOTOR ENABLE	RIGHT MOTOR ENABLE	
B					GO FWD	REM FWD	FWD				SEL	RIGHT BRAKE DRIVER
					WRITE ENBL		ALL HALT	DIR			RIGHT MOTOR ENABLE	
					LOCAL	BRAKE ENBL	SEL		REM STOP	REM GO	LEFT MOTOR ENABLE	
					REMOTE		WR EN				WR ENBL	

* LOCATIONS FOR UNIT TO UNIT BUS CONNECTIONS.

NOTES:

- FOR MODULE COUNT SEE PARTS LIST
*A-PL-TU55-0-5

Module Utilization List MU-D-TU55-0-5

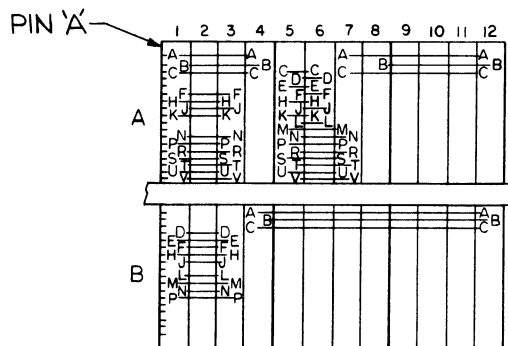

NOTES:

- JUMPER A Ø 4C TO A Ø 7C

Bus Bar for TU55 WD-D-TU55-0-4

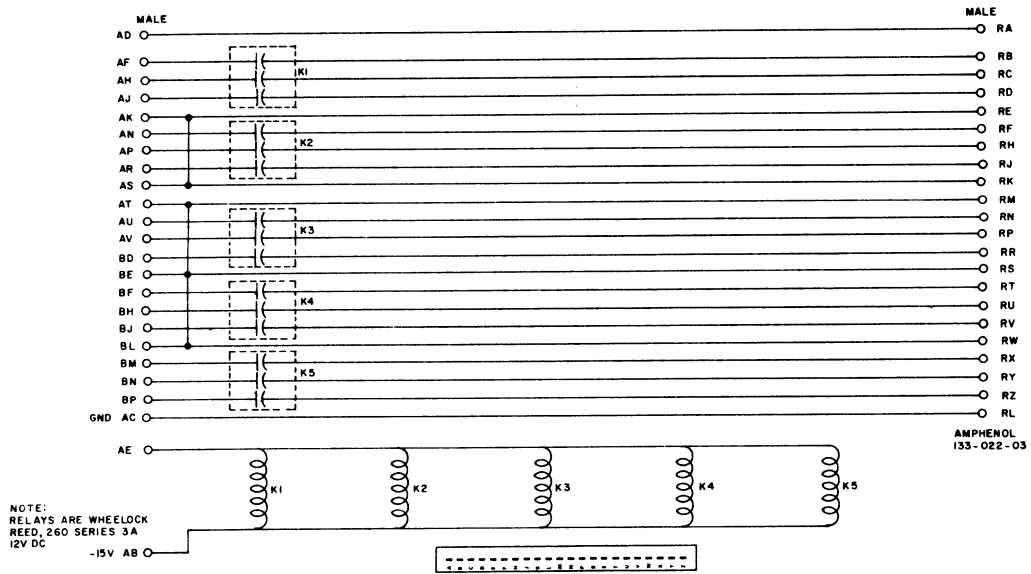

Relay RS-B-G851

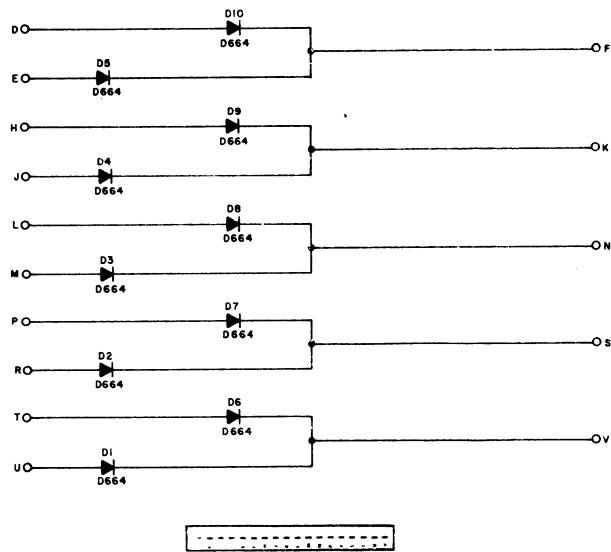

Diode Cluster RS-B-R002

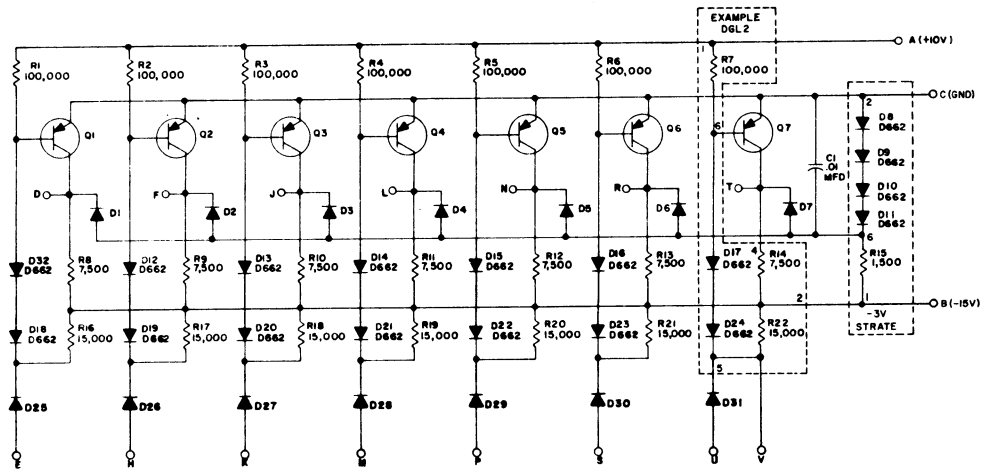

UNLESS OTHERWISE INDICATED:
 RESISTORS ARE 1/4W, 5%
 DIODES ARE D-664
 TRANSISTORS ARE DEC 3639B
 PRINTED CIRCUIT REV. FOR
 DGL BOARD IS SIA

Inverter RS-B-R107

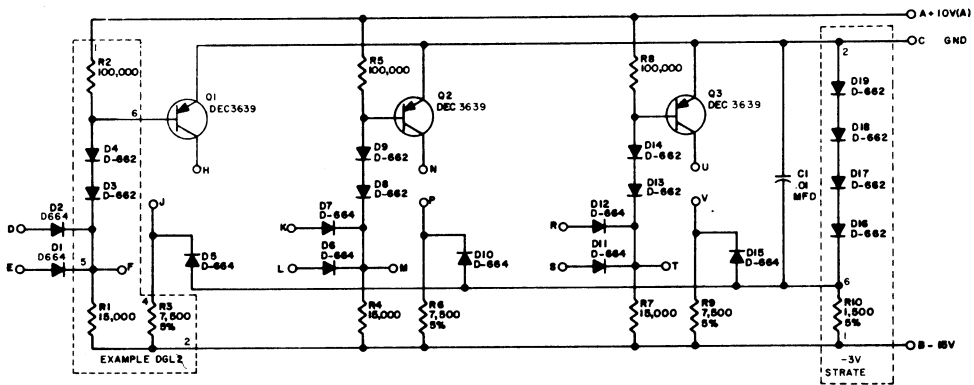

UNLESS OTHERWISE INDICATED:
 RESISTORS ARE 1/4W, 5%
 DIODES ARE D-664
 PRINTED CIRCUIT REV. FOR
 DGL BOARD IS SIB

Diode Gate RS-B-R111

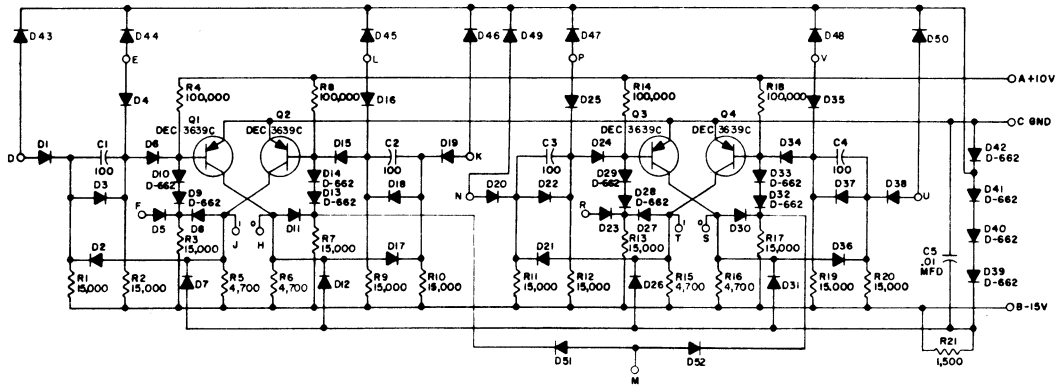

UNLESS OTHERWISE INDICATED:
 RESISTORS ARE 1/4W, 5%
 CAPACITORS ARE MMFD
 DIODES ARE D-664

Dual Flip-Flop RS-B-R202

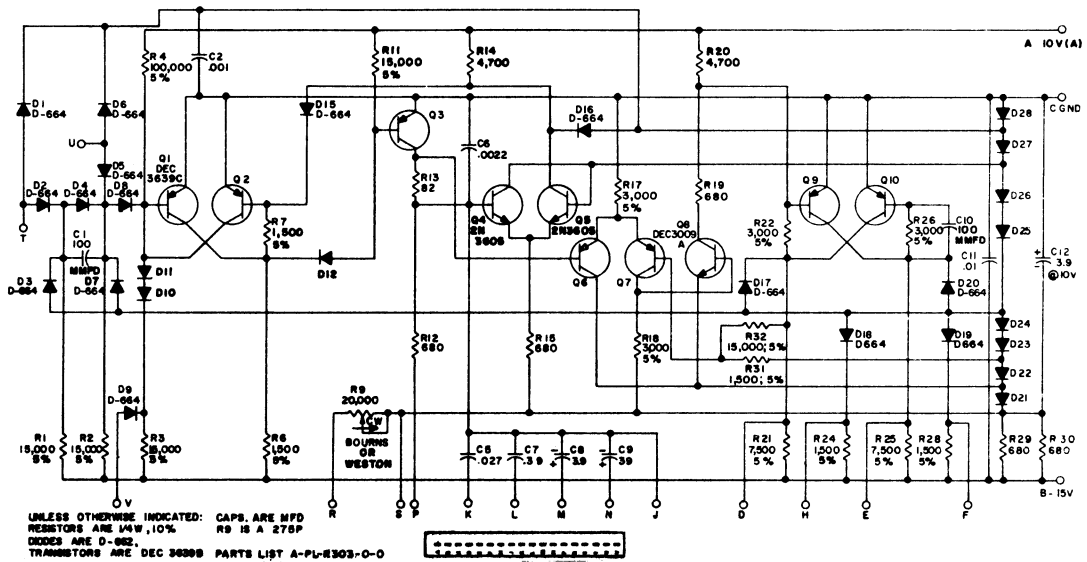

UNLESS OTHERWISE INDICATED: CAPS. ARE MFD
 RESISTORS ARE 1/4W, 10% R9 IS A 275P
 DIODES ARE D-664,
 TRANSISTORS ARE DEC 3608 PARTS LIST A-PL-R303-O-O

Integrating One-Shot RS-B-R303

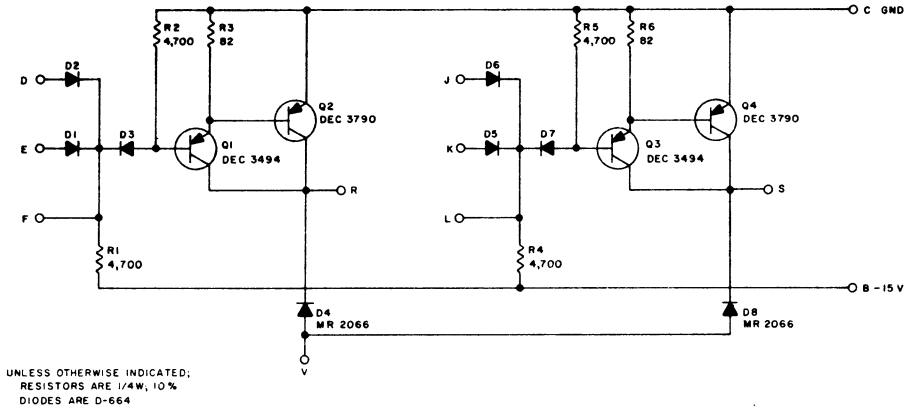

Solenoid Driver RS-B-W040

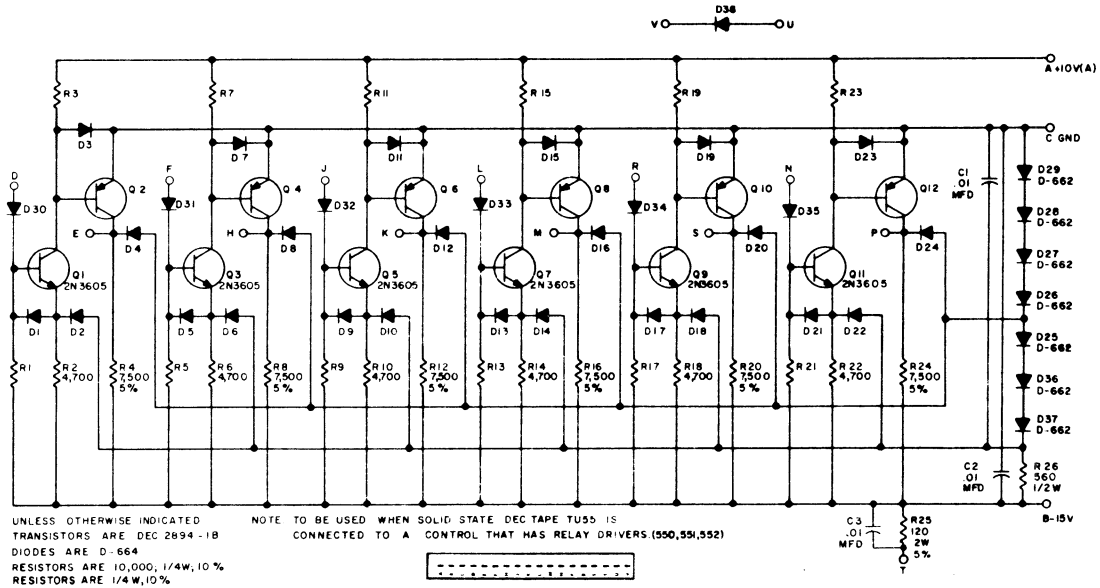

Level Amplifier RS-B-W513

digital

DIGITAL EQUIPMENT CORPORATION □ MAYNARD, MASSACHUSETTS

Printed in U.S.A.