

# INSTRUCTION MANUAL for the MODEL 563

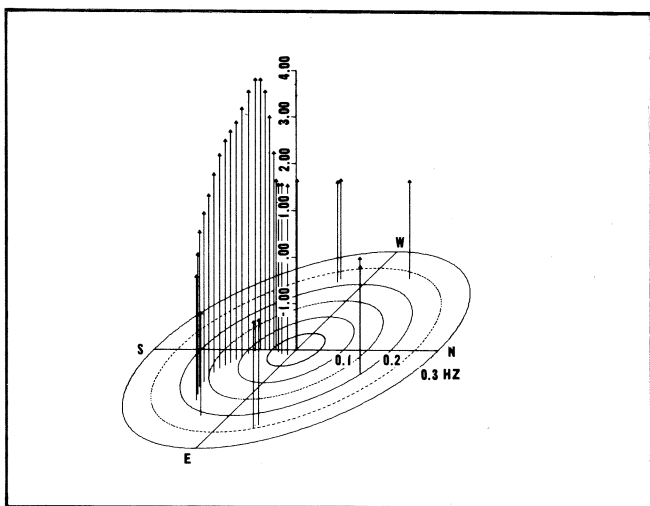

CALCOMP

CALCOMP

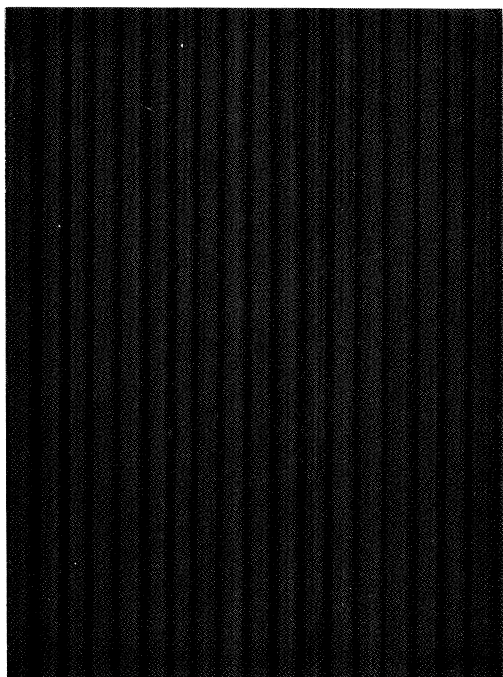
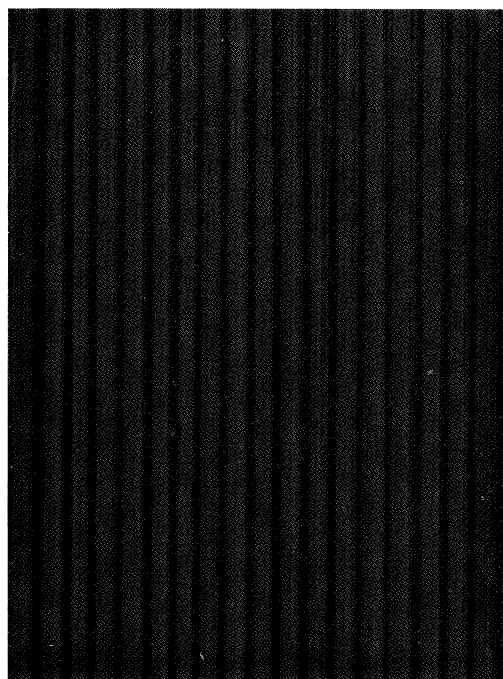

CALCOMP

CALCOMP

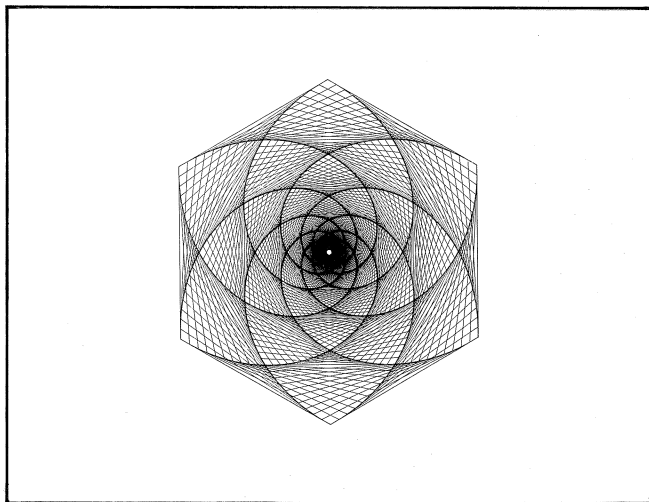



**MODEL 563  
DIGITAL INCREMENTAL PLOTTER  
INSTRUCTION MANUAL**

**DECEMBER 1969**



**CALIFORNIA COMPUTER PRODUCTS, INC.  
2411 West La Palma Anaheim, California 92801**

Copyright © 1969, by  
CALIFORNIA COMPUTER PRODUCTS, INC.

This document contains proprietary information of California Computer Products, Inc. (Company) and is submitted in confidence. Recipient agrees not to disclose or use the information contained herein except in connection with Company products, or reproduce in whole or in part without written permission from the Company.

Printed in the United States of America

## CONTENTS

<u>Section</u>	<u>Title</u>	<u>Page</u>
1	GENERAL DESCRIPTION	
	1.1 Introduction . . . . .	1
	1.2 Functional Description . . . . .	1
2	INSTALLATION	
	2.1 Introduction. . . . .	5
	2.2 Unpacking . . . . .	5
	2.3 Inspection . . . . .	5
	2.4 Cable Fabrication . . . . .	5
	2.5 Installation of Chart Paper . . . . .	5
	2.6 Installation of Pen . . . . .	6
	2.7 Installation Precautions . . . . .	6
3	THEORY OF OPERATION	
	3.1 General . . . . .	7
	3.2 Detailed Theory . . . . .	7
	3.2.1 Step Motors . . . . .	9
	3.2.2 Reversible Ring Counters . . . . .	9
	3.2.3 One-Shot (Clock Pulse Multivibrators) . . . . .	10
	3.2.4 Pen Solenoid Control Circuit . . . . .	11
	3.2.5 Drum and Carriage Manual Control Circuits . . . . .	12
	3.2.6 Pen Solenoid Manual Control Circuit . . . . .	13
	3.2.7 AC Power Distribution and DC Power Supply . . . . .	13
4	OPERATING INSTRUCTIONS	
	4.1 Introduction . . . . .	19
	4.2 Control Functions . . . . .	19
	4.2.1 Power On/Off . . . . .	19
	4.2.2 Carriage Fast Run . . . . .	19
	4.2.3 Carriage Single Step . . . . .	19
	4.2.4 Chart Drive-On/Off . . . . .	19
	4.2.5 Pen Up/Down . . . . .	19
	4.2.6 Drum Fast Run . . . . .	19
	4.2.7 Drum Single Step . . . . .	19
	4.3 Operating Procedures . . . . .	20
	4.3.1 Installation of Chart Roll . . . . .	20
	4.3.2 Installation of Single Sheet Chart Paper . . . . .	21
	4.3.3 Operational Checkout . . . . .	21
	4.3.4 Scale Factor Adjustment . . . . .	21
	4.3.5 Reticles . . . . .	22
	4.3.6 Automatic Operation . . . . .	23
	4.3.7 Removal of Chart Paper . . . . .	23

CONTENTS (Continued)

<u>Section</u>	<u>Title</u>	<u>Page</u>
5	MAINTENANCE	
5.1	Introduction . . . . .	25
5.2	Routine Maintenance . . . . .	25
5.3	Disassembly . . . . .	25
5.4	Replacement and Adjustments . . . . .	27
5.4.1	Step Motor Replacement and Adjustment . . . . .	27
5.4.2	Carriage Cable Replacement . . . . .	29
5.4.3	Paper Feed Roll Adjustment . . . . .	32
5.4.4	Carriage Scale Factor Recalibration . . . . .	33
5.5	Troubleshooting . . . . .	34
5.5.1	Drum and Carriage Control Waveforms . . . . .	36
5.5.2	Pen Control Waveforms . . . . .	37
6	PARTS LIST	

## ILLUSTRATIONS

<u>Figure</u>	<u>Title</u>	<u>Page</u>
1-1	CalComp Model 563 Digital Incremental Plotter . . . . .	1
1-2	Functional Diagram of the Model 563 . . . . .	2
3-1	Detailed Block Diagram . . . . .	8
3-2	Step Motor Drive Circuit, Simplified Schematic . . . . .	9
3-3	Circuit Board Layout . . . . .	14
3-4	Schematic Diagram, Drum Step Motor Control Circuits . . . . .	15
3-5	Schematic Diagram, Pen Solenoid Control Circuits . . . . .	16
3-6	Schematic Diagram, Carriage Step Motor Control Circuits . . . . .	17
3-7	Schematic Diagram, Main Assembly . . . . .	18
4-1	Model 563 Control Panel . . . . .	20
4-2	Carriage Scale Factor Adjustment . . . . .	22
4-3	Reticle Adjustment . . . . .	22
5-1	Rear Oblique View, Cover Removed . . . . .	26
5-2	Rear View, Plug-In Assemblies Removed . . . . .	26
5-3	Pen Assembly . . . . .	27
5-4	Location of Cover and Power Supply Mounting Screws . . . . .	28
5-5	Carriage Cable Replacement . . . . .	30
5-6	Carriage Cable Wiring . . . . .	31
5-7	Paper Feed Roll Adjustment . . . . .	33
5-8	Carriage Scale Factor Recalibration . . . . .	33
6-1	Main Assembly, Location of Parts . . . . .	41
6-2	Power Supply Assembly . . . . .	45
6-3	Terminal Board Assembly . . . . .	46
6-4	Terminal Board Assembly . . . . .	47
6-5	Terminal Board Assembly . . . . .	48
6-6	Plotter Driver Assembly . . . . .	49
6-7	Location of Electronic Parts (Plotter as Viewed From Bottom) . . . . .	52

## TABLES

<u>Table</u>	<u>Title</u>	<u>Page</u>
1-1	Specifications . . . . .	3
5-1	Troubleshooting Guide . . . . .	35
5-2	Voltage Test Points . . . . .	36
6-1	Part Numbers Dependent on Step Size . . . . .	39
6-2	Loose Equipment . . . . .	39



## SECTION 1 GENERAL DESCRIPTION

### 1.1 INTRODUCTION

This manual provides operation and service instructions for the Digital Incremental Plotter Model 563, manufactured by California Computer Products, Inc., Anaheim, California. The manual also contains a detailed description of the theory of operation, a parts list, and a complete set of schematic diagrams.

### 1.2 FUNCTIONAL DESCRIPTION

An overall view of the complete equipment is shown in Figure 1-1, and a simplified functional diagram in Figure 1-2.

The Model 563 is a high-speed, drum-type plotter designed for plotting one variable against another. The instrument responds to digital incremental signals from any suitable source. The actual plot is produced by the movement of a pen over the surface of the chart paper.

The Y-axis plot is produced by lateral movement of the pen carriage and the X-axis plot by rotary motion of the chart drum. Provision for Z-axis modulation is also incorporated through the use of a pen solenoid which permits the pen to be lifted or lowered to the plotting surface in response to electrical input signals.

The plotter employs a bi-directional rotary step motor on both the X- and Y-axis drives. Each step causes the drum or pen carriage to move a fixed increment in either a positive or a negative direction. The size of this increment can be 0.010 inch, 0.005 inch, or 0.1 mm, depending on the ratios of the gears used for the drum and carriage drives. The step motors are capable of operating at a rate of up to 300 steps per second.

A roll paper feed and takeup mechanism is provided which accepts chart paper rolls 31 inches wide by 120 feet long. The feed and takeup mechanism is bidirectional. The paper is driven by pins on the drum which

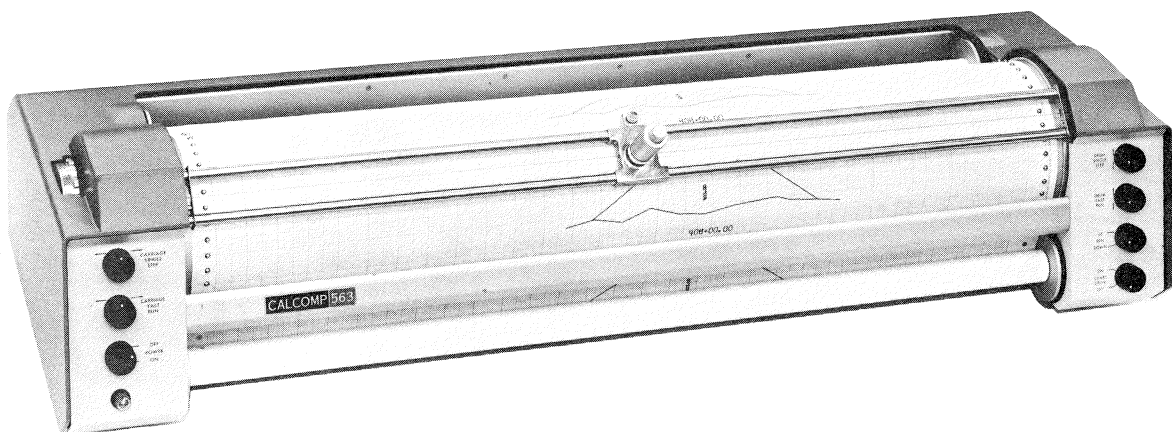

FIGURE 1-1  
CalComp Model 563 Digital Incremental Plotter

engage holes on both edges of the paper, thus maintaining accurate registration between the recording pen and the paper. If desired, single sheets of chart paper may be used for plotting instead of the roll paper supplied.

A total of twelve signal inputs is provided, so that signals of either positive or negative polarity may be used to actuate the plotter in each of the six operating modes: Drum Up, Drum Down, Carriage Left, Carriage Right, Pen Up, and Pen Down. In addition, front panel controls are provided for each of these modes. All electrical inputs are capacitively coupled inside the plotter, thereby eliminating dependence on absolute voltage levels.

The Model 563 is completely transistorized, with most of the electronic circuitry mounted on a removable etched circuit board and a plug-in power supply assembly. The unit operates from any source of 115-volt, 50- or 60-cycle, single-phase power capable of delivering 1.5 amps.

The Digital Incremental Plotter can be used for on-line operation with a number of general-purpose digital computers. A special adapter is used to convert the computer output signals to a form suitable for driving the plotter. When the Model 563 is used as an integral part of the California Computer Products Models 470, 750, or 760 Magnetic Tape Plotting Systems, the special adapter is not required.

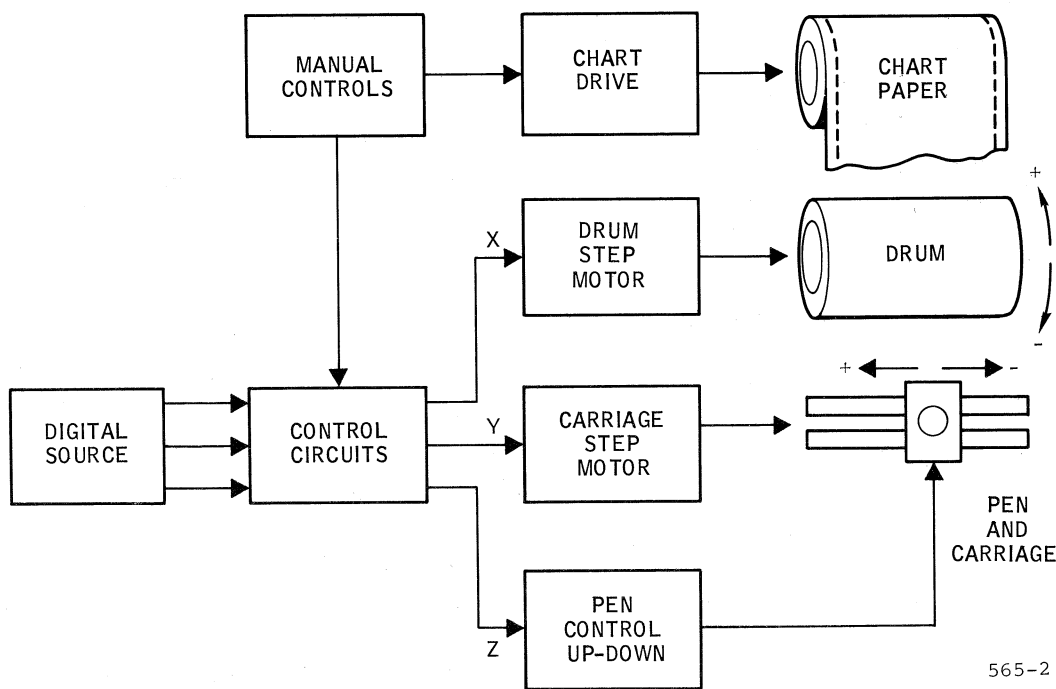

FIGURE 1-2  
Functional Diagram of the Model 563

TABLE 1-1  
Specifications

SPEED:	<p>Drum axis: 300 steps per second maximum for 0.005-inch and 0.1-mm steps; 200 steps maximum for 0.010-inch steps.</p> <p>Carriage axis: Same as drum axis.</p> <p>Pen: 10 operations, 5 up and 5 down per second maximum</p>
STEP SIZES:	0.01 or 0.005 inch, or 0.1 mm on both drum and carriage.
RESOLUTION:	±1 step on either axis over entire 120-foot roll of paper
INPUTS:	Pulses of either positive or negative polarity with amplitude in excess of 10 volts, rise time less than 10 microseconds, minimum width of 4 microseconds, from a source impedance of less than 500 ohms (input circuits may be modified for specific pulse characteristics).
POWER:	105 to 125 volts, 50 or 60 cycles, single-phase (1.5 amps at 115 volts).
WEIGHT:	53 pounds.
SIZE:	<p>Width – 39-3/8 inches</p> <p>Depth – 14-3/4 inches excluding mating connectors.</p> <p>Height – 9-3/4 inches to top of pen holder.</p>
PAPER SIZE:	Roll chart paper – 31 inches wide, 120 feet long, sprocket holes 0.187-inch diameter on 0.5-inch centers.



## SECTION 2 INSTALLATION

### 2.1 INTRODUCTION

The Model 563 Digital Incremental Plotter is shipped in a single packing container. Installation of the unit is simple and requires no special tools or test equipment. It is completely self-contained and may be operated on any level surface that is not subject to excessive vibration.

Special adapter units are provided for on-line operation of the Model 563 with general-purpose digital computers. Installation instructions are included in the instruction manuals supplied with the adapters.

### 2.2 UNPACKING

The Model 563 is shipped completely assembled except for the pen assembly, which is packed separately within the shipping container. A roll of chart paper is installed on the rear chart spool. Separate rolls of chart paper are supplied in separate boxes within the shipping container. To unpack the unit, proceed as follows:

- a. Remove the packing material and plywood cover from the top of the crate. Take out the boxed rolls of chart paper that are on top of the unit, and the accessories that are at the end of the crate. Check items against the packing slip.
- b. Remove the plywood liner and packing material from around the plotter, and lift the plotter with plywood shipping base from the crate.
- c. Carefully lay the plotter upside down on a piece of the packing material removed from the crate, and remove the three 1/4-inch cap screws securing it to the shipping base.
- d. Set the plotter upright and remove the plastic dust cover.

#### NOTE

It is recommended that the shipping container, liner, and accessory boxes be stored for reuse whenever the

instrument is transported between operating sites or returned to the factory for service.

### 2.3 INSPECTION

After unpacking the instrument, check for signs of physical damage in shipment. Make certain that all front panel controls are secure on the control shafts. Check that the pen carriage can be moved freely by hand across its track, and that the drum can be rotated manually on its axis.

### 2.4 CABLE FABRICATION

A female cable connector is supplied with the unit. This connector mates with chassis connector P5 on the rear of the Model 563 (see Figure 5-1). A signal cable of desired length to interconnect the plotter and the digital signal source can be made by following the signal nomenclature for connector P5 as shown in the schematic diagram of Figure 3-7.

### 2.5 INSTALLATION OF CHART PAPER

To install the chart paper shipped on the rear chart spool, pull the end of the paper over the drum so that the holes on both edges of the paper engage the sprockets on the drum. Guide the chart paper under the carriage rods and behind the tear bar. The chart paper winds on the take-up spool from the back; fasten the end on the spool with Scotch tape provided in the accessory kit. Using the DRUM FAST RUN switch, wind a few turns onto the take-up spool.

#### NOTE

If the paper does not lie smoothly against the drum, or if it tends to pull diagonally so that the pinholes do not engage properly, check the feed spool adjustment in Paragraph 5.4.3. This condition may result from large changes in humidity that have caused the paper roll to shrink or expand slightly.

To remove chart paper, grasp the paper roll and press the left-hand idler spool to the left. This compresses the spring on the idler spool allowing the roll to be removed. To insert a new roll of chart paper, see instructions in Paragraph 4.3.1.

## 2.6 INSTALLATION OF PEN

Ballpoint pens normally supplied with the recorder are black, blue, red, and green. The components of the pen assembly are illustrated in Figure 5-3. To assemble the pen, insert the desired color pen into the plunger, then insert the pen and plunger into the holder and install the threaded cap. Align the key on

the holder with the key slots in the carriage and press the pen assembly into the pen mounting. Tighten the knurled nut on the bottom of the pen assembly.

## 2.7 INSTALLATION PRECAUTIONS

The Model 563 depends upon free circulation of air under the base plate for proper cooling. Do not place the unit on top of any loose papers or cloth. Loose materials of this type can block the ventilating louvres in the base plate and cause overheating. In addition, the unit should not be placed on top of any other heat-producing equipment.

## SECTION 3 THEORY OF OPERATION

### 3.1 GENERAL

The block diagram of Figure 3-1 illustrates the operation of the Model 563 in terms of signal flow and functional circuits. Inputs to the plotter from the digital signal source consist of drum up and drum down, carriage left and carriage right, and pen up and pen down pulses. These three groups of signals are generally referred to as the X-axis, Y-axis, and Z-axis signals, respectively.

The control circuits of the Model 563 are designed so that either positive-going or negative-going pulses can be utilized to produce the incremental stepping action and to control the pen solenoid. Separate signal lines are provided for positive and negative inputs to the control circuits, so that these operations may be used in any combination.

The X-axis signals from the digital source are applied to separate one-shot multivibrators which in turn control the action of a reversible ring counter, through suitable diode gating circuits. The ring counter consists of three stages, each of which supplies current to one pair of stator coils in the drum step motor. The design of the ring counter is such that only one pair of coils can receive current at any given time. When an incoming pulse causes one of the one-shots to be triggered, the one-shot causes the ring counter to change state. The direction of change depends upon whether the incoming pulse was a drum up or a drum down signal.

When the ring counter changes state, the step motor current is switched from one pair of coils to an adjacent pair. This causes the motor to rotate one-twelfth of a revolution clockwise or counterclockwise. The drum step motor is connected to the drum through a reduction gear train

Manual positioning of the drum is provided by two front panel controls which allow the drum to be advanced up or down in single steps, or continuously at the rate of 120 steps per second.

The Y-axis signals from the digital source are applied to the carriage control circuit. This circuit and the carriage step motor are identical to the drum control

circuit and step motor described above. Front panel controls are also provided for manual positioning of the carriage.

The Z-axis signals from the digital source are utilized to control a pen solenoid which, when energized, lifts the pen off the chart. The incoming pen up and pen down pulse signals are applied to a bistable multivibrator (flip-flop). The flip-flop acts as an electronic switch that controls current to the pen solenoid through suitable control stages and a current driver. Manual control of the pen solenoid is provided by means of a front panel switch.

The remaining functional circuits of the Model 563 are the chart takeup motors and the power supply. The chart motors operate in a stalled condition to maintain proper tension on the chart spools. A front panel on-off switch is provided to allow the chart motors to be disabled when single sheets of graph paper are used in place of the continuous roll. (See operating instructions in Section 4.)

The power supply consists of a silicon bridge rectifier and filter-divider components. The supply provides two positive and three negative output voltages, referenced to a circuit ground that is isolated from the instrument chassis. The output voltages from the power supply are:

<u>Nominal</u>	<u>Actual*</u>
+ 3.0 vdc	+ 3.2
+ 1.5 vdc	+ 2.2
- 7.5 vdc	- 7.1
- 9.0 vdc	- 8.5
-24.0 vdc	-22.0

\*Voltage levels measured with a dc voltmeter.

### 3.2 DETAILED THEORY

A simplified schematic diagram of the drum step motor is shown in Figure 3-2. Figure 3-3 illustrates the physical layout of the printed circuit board which contains the drum, carriage, and pen solenoid control circuits. The schematic diagram for the circuit board is divided into three sections, corresponding to the three functional circuits. The drum control, solenoid control, and carriage control circuits are shown in

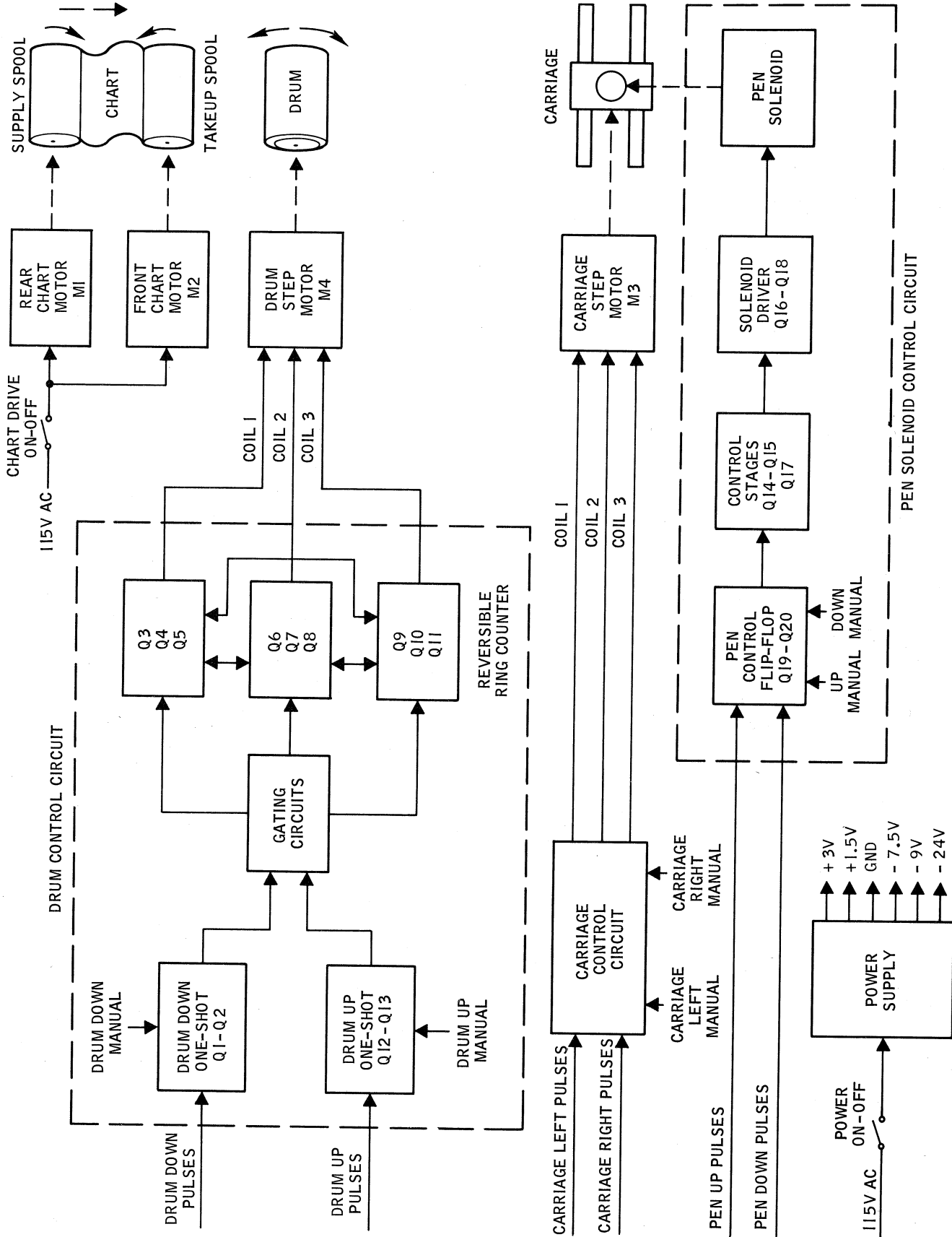

FIGURE 3-1  
Detailed Block Diagram

Figures 3-4, 3-5, and 3-6, respectively. The schematic diagram for the main chassis, the control panel and the power supply subassembly is shown in Figure 3-7.

### 3.2.1 STEP MOTORS

The motor (Figure 3-2) consists of a stator with three pairs of poles arranged symmetrically around a four-pole soft iron rotor. Each of the three pairs of poles has a separate current winding that is controlled by a transistor current driver. The motor advances one-twelfth of a revolution each time the current is switched off in one stator winding and switched on in another winding. The direction of rotation is determined by the sequence in which the windings are energized.

For illustrative purposes, the three pairs of stator windings shown in Figure 3-2 are numbered 1, 2, and 3. The four poles of the rotor are designated a, b, c, and d. Assume that driver stage Q5 is conducting. The circuit is designed so that when Q5 conducts, Q8 and Q11 are cut off. Current therefore flows only in stator winding No. 1. This current creates a magnetic field which holds poles a and c of the rotor in alignment with the No. 1 stator poles. If transistor Q5 is now switched off and Q8 is switched on, the rotor will turn until one pair of its poles is aligned with the poles of stator winding No. 2. Since poles b and d are the closest to the No. 2 stator poles, the rotor will step counterclockwise.

In the above example, if driver stage Q11 were switched on instead of Q8, the rotor would step clockwise until poles b and d were in alignment with the poles of stator winding No. 3.

From the foregoing it can be seen that if the current is continuously switched between windings in a clockwise sequence (i.e., 1-2-3-1-2-3, etc.), the rotor will step counterclockwise. Conversely, if the switching sequence is counterclockwise, the rotor will step clockwise.

The rotor shaft of the drum step motor is coupled to the drum through a reduction gear train. The gear train determines the step size of the plotter.

The mechanical and electrical design of the carriage step motor and its associated circuit are identical to that of the drum step motor. On both motors, the pinion is mounted off center. This permits the backlash between the pinion and the drum or carriage gear to be adjusted to zero.

Resistors R13, R11, and R16, shown in Figure 3-2, are current limiters. The corresponding limiting

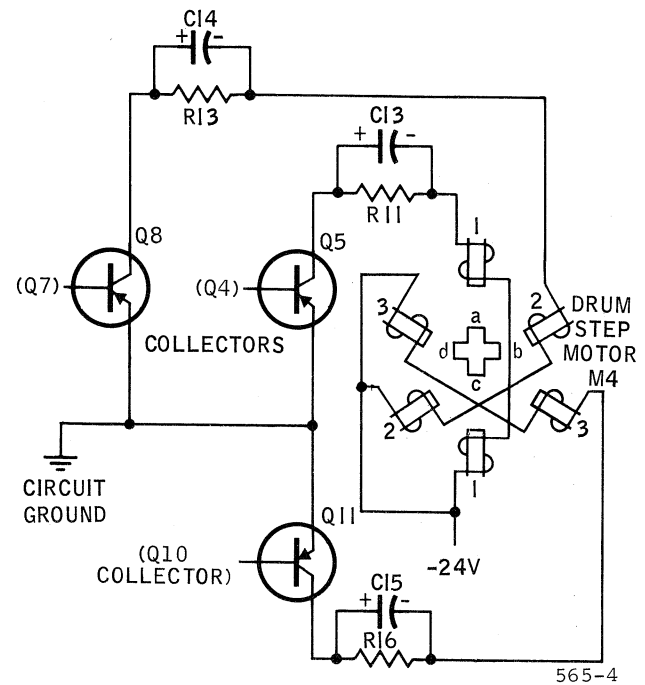

FIGURE 3-2

Step Motor Drive Circuit, Simplified Schematic

resistors for the carriage step motor are R12, R14 and R15. Across each of these resistors is a capacitor to provide proper wave-shaping and acceleration of the step motor. C13, C14 and C15 are the drum step motor capacitors, and C10, C11 and C12 are the carriage step motor capacitors.

A suppression diode is connected across each of the three windings in both step motors to damp out the high counter-emf generated by the decaying magnetic field when the current is switched off. The suppression diodes, shown in Figure 3-7, are CR14, CR16 and CR18 for the carriage step motor and CR14, CR15 and CR17 for the drum step motor.

### 3.2.2 REVERSIBLE RING COUNTERS

The carriage and drum step motors described in the preceding paragraphs are each driven by a reversible three-stage ring counter. The ring counter associated with the drum step motor consists of transistors Q3 through Q11 (Figure 3-4). The ring counter for the carriage step motor consists of transistors Q23 through Q31 (Figure 3-6). Since the two circuits are identical, only the drum ring counter circuit will be described.

Referring to Figure 3-4, assume that transistor current driver Q5 is conducting, supplying current to coil 1 of the drum step motor. Since only one driver stage can be in conduction at any given time, Q8 and Q11

are cut off. In the absence of a clock pulse from the drum up or drum down one-shot multivibrator, the ring counter is held in this state in the following manner: Control stage Q3, an NPN transistor, is non-conducting, since its emitter is connected to -7.5 volts and its base is returned to -9 volts through R16-R35 and R17-R30. The base potential is held at approximately -8.5 volts. Since no collector current can flow in Q3, the base of Q4 is held at approximately +3volts, through resistor R19. The emitter of Q4, a PNP transistor, is returned to +1.5 volts. Thus, Q4 is also non-conducting. Since there is no collector current through Q4, the base of Q5 is biased negative with respect to its emitter and Q5 conducts.

Since the emitter of Q5 is at ground potential, and the step motor coil is returned to -24 volts (see Figure 3-2). the collector of Q5 will be at approximately ground potential while this stage is conducting. Diode CR8 conducts, since its cathode is returned to -9 volts through resistor R32. The bases of Q6 and Q9 are therefore returned to ground potential through CR8 and resistors R24 and R33, respectively. Both Q6 and Q9 are thus driven into conduction. The collector current of Q6 is supplied from the base of Q7 and the collector current of Q9 is supplied from the base of Q10. Consequently, Q7 and Q10 are saturated. The bases of Q8 and Q11 are at approximately 1.5 volts, and the emitters are at ground potential, hence these transistors are cut off.

Assume that with the ring counter in the state described above, a drum down clock pulse is applied at pin R of connector P1. Pin R is normally at approximately -7 volts, and is driven positive to essentially ground potential during the clock pulse period of approximately 1500 microseconds. This positive-going pulse is applied to the cathodes of diodes CR6, CR10, and CR12, but will affect only CR10. The anodes of CR6 and CR12 are returned to -9 volts through resistors R14-R35 and R28-R30 respectively. Thus, these diodes were initially cut off and will remain cut off during the clock pulse period. However, CR10 was initially conducting, since its associated resistor R22 is returned to ground potential through diode CR8 and conducting driver stage Q5. Capacitor C6 is therefore initially uncharged, with about -7 volts on each side. The positive-going clock pulse at the cathode of CR10 cuts off the diode and C6 charges through R22 and the base-to-emitter circuit of Q6. At the end of the clock pulse, when the voltage at pin R returns to -7 volts, the clock pulse is capacitively coupled through C6, causing a

negative-going pulse to appear at the base of Q6. This negative pulse cuts off Q6, which in turn cuts off Q7 and allows Q8 to conduct, supplying current to coil 2 of the drum step motors.

The collector of Q8 is now at ground potential, and resistors R17 and R31 are therefore returned to ground potential through diode CR11. This causes both Q3 and A9 to conduct. Q4 and Q10 also conduct, switching Q5 off and keeping Q11 cut off in the manner described previously. Gating diodes CR6 and CR10 are now cut off and CR12 is conducting. Thus, if another drum down clock pulse is applied to the circuit, capacitor C9 will drive the base of Q9 negative and Q11 will conduct.

The gating diodes associated with the clock drum up signal input at pin U of P1 are CR7, CR9 and CR13. The action of this circuit is the same as that of the clock drum up circuit, except that the counter changes state in the reverse direction when a clock pulse is applied at pin U.

### 3.2.3 ONE-SHOT (CLOCK PULSE) MULTIVIBRATORS

The clock drum up and clock drum down signals which control the ring counter circuit described above are provided by one-shot multivibrator circuits. A separate multivibrator is provided for the drum up and drum down functions, and for the carriage left and carriage right functions. The multivibrators for these four functions, shown schematically in Figures 3-4 and 3-6, are Q1-Q2, Q12-Q13, Q21-Q22, and Q32-Q33, respectively. Since all four circuits are identical, only the drum down circuit will be described in detail.

The purpose of the one-shot multivibrator is to provide isolation between the digital signal source and the ring counter circuits, and to provide a time delay during which the circuit will not accept another step signal. This delay period, equal to 1500 microseconds, protects the ring counter against double stepping due to transients or noise.

As shown in Figure 3-4, either a positive-going or a negative-going signal may be used to trigger the drum down multivibrator. In the absence of an input signal from the digital source, transistor Q1 is normally conducting and Q2 is cut off. The regenerative cycle may be initiated by applying a negative pulse to the base of Q1, cutting off this stage, or by applying a positive pulse to the base of Q2, driving this stage into

conduction. Conventional cross-coupling holds Q1 cut off and Q2 in conduction for a period of time determined by the RC time constant of C2 and R5. This period is set to a nominal value of 1500 microseconds. When the base potential of Q1 decays to a value equal to the emitter potential, this stage again conducts and its negative-going collector voltage cuts off Q2. The circuit then remains in its original state until another trigger pulse is received.

Assume that a negative input signal is to be used to trigger the multivibrator. Negative-going pulses from the digital source are applied to pin Y of connector P1. Resistor R1 and capacitor C36 form a voltage divider and r-f filter across the input signal line. The negative signal is coupled by capacitor C1 to the junction of resistors R4 and R3 which form a voltage divider between +3 and -7.5 volts. The voltage divider establishes a bias level at the cathode of diode CR3 which determines the minimum signal amplitude required to trigger the multivibrator.

Diodes CR1 and CR2 function as positive and negative clamps to prevent very large voltage spikes from damaging the circuit components. When such spikes occur, R1 also functions as a current limiter.

If a positive input signal is to be used to trigger the multivibrator, the pulses from the digital source are applied to pin W of connector P1. Resistor R12 and capacitor C30 are equivalent to R1 and C36 in the negative input circuit. Diode CR5 functions as a negative clamp, equivalent to CR2, and the base-to-emitter diode action of Q2 serves as a positive clamp, equivalent to CR1. The voltage divider action of R10 and R11 determines the anode potential for CR4, which establishes the minimum pulse amplitude required to trigger the multivibrator.

When the multivibrator is triggered, Q1 is cut off for a period of 1500 microseconds. This causes the voltage at the function of R7 and R8 to rise from approximately -7 volts to essentially ground potential for the same 1500-microsecond period. This comprises the clock drum down signal output, which is connected from pin Z through an external jumper to pin R at the input to the ring counter circuit.

Manual drum step signals are applied to the multivibrator circuit through diode CR5. The manual input signal may consist of either a single positive-going pulse, or a continuous series of 120-cps positive-going pulses. (See paragraph 3.2.5.)

The operation of the carriage left and carriage right one-shot multivibrators is identical to that of the drum up and drum down multivibrators. However, the multivibrator output (clock) signals are connected to the carriage ring counter through left and right limit switches. (See Figure 3-7.) The limit switches disconnect the associated multivibrator output whenever the carriage has reached the left or right limit of travel, and thus prevent further stepping action in that direction.

### 3.2.4 PEN SOLENOID CONTROL CIRCUIT

The schematic diagram for the pen solenoid control circuit is shown in Figure 3-5. In this circuit a bistable multivibrator, or flip-flop, is used for current control instead of the one-shot multivibrators used in the step motor control circuits. The flip-flop, consisting of transistors Q19 and Q20, remains in the state to which it was set by the last signal pulse, until another signal pulse causes it to change state. The flip-flop triggering circuit is designed so that pulses of either polarity may be used to set the flip-flop to either state.

In the normal, or pen down state, Q19 is conducting and Q20 is cut off. The flip-flop can be switched to the pen up state by applying a negative trigger pulse at the base of Q19 or a positive trigger pulse at the base of Q20. Q19 will then be held cut off by the negative voltage at the collector of Q20, and Q20 will be held in conduction by the positive voltage at the collector of Q19. The flip-flop will then remain in the pen up state until a positive trigger pulse is applied to the base of Q19 or a negative pulse to the base of Q20.

The input trigger circuits for the pen control flip-flop are similar to those used for the delay multivibrators in the drum and carriage control circuits. For example, in the pen up negative input circuit, R64 and C38 form a voltage divider and r-f filter circuit. The negative signal is coupled by capacitor C14 to the junction of voltage divider resistors R68 and R69. These resistors establish the bias level for diode CR25, which determines the minimum signal amplitude required to trigger the flip-flop. Diodes CR24 and CR23 function as positive and negative clamps to protect the circuit against large voltage spikes. The input circuits for pen down positive, pen up positive, pen up negative, and pen down negative signals are similar.

Manual pen up and pen down signals are applied to the flip-flop through diodes CR30 and CR26, respectively,

Both of the manual inputs consist of a single positive-going pulse. (See subsection 3.3.6.)

The output voltage from the pen control flip-flop, obtained from the junction of resistors R73 and R74, is applied to the base of the driver transistor Q18. When the flip-flop is in the pen down state, Q20 is cut off and this voltage is approximately +3 volts. Q18 is therefore biased off. When the flip-flop changes state, Q20 conducts and the base of Q18 becomes negative. Q18 is driven into conduction and supplies current to the pen solenoid.

The driver transistor Q18 performs a dual function in the pen control circuit. It supplies current to actuate transistor Q14, and it supplies a continuous holding current to keep the solenoid retracted as long as the flip-flop remains in the pen up state. When Q18 is first driven into conduction its collector voltage changes very rapidly from a negative potential to ground potential. This causes a large positive pulse to be coupled through capacitor C13 to the cathode of diode CR20. Transistor Q14 is normally biased on by the voltage divider action of R54, CR20 and R53, which maintains a negative potential at the base. When the positive pulse appears at the cathode of CR20, the diode is cut off and the base of Q14 then becomes positive, since resistor R54 is returned to +3 volts. Transistor Q14 is therefore cut off, and its collector voltage goes negative. Since the collector is tied to the base of Q16, this negative voltage now causes Q16 to conduct. Q16 supplies a surge of current to the pen solenoid through pin J of Pl. This initial surge is sufficient to overcome inertia and lift the pen from the paper. Q14 remains cut off and Q16 conducts for a period determined by the RC time constant of C13 and R53. The voltage at the cathode of CR20 decreases exponentially as C13 charges, and when the cathode becomes more negative than +1 volt, diode CR20 will again conduct and Q14 will be driven into conduction. The collector current of Q14 produces a voltage drop across resistors R55 and R56 which cuts off Q16. At this time, only the holding current is supplied to the solenoid, through the collector of Q18, resistor R63, and diode CR22. The nominal value of holding current is approximately 35 ma.

From the foregoing, it will be seen that if the pen and its solenoid are removed from the carriage while the circuit is in the pen up state, only the holding current will be supplied to the solenoid when the pen is replaced. This will also occur if the flip-flop assumes the pen up state when power is first applied. The pen

therefore will remain down even though the flip-flop is in the pen up state and pen up signals will have no effect. In this event, the manual control must be turned first to PEN DOWN, and then to PEN UP. The pen down signal will reset the flip-flop to the down state, and the pen up signal will set it to the up state. As the flip-flop switches back to the pen up state, the initial surge of current supplied by Q16 will lift the pen.

Transistors Q15 and Q17 with their associated components comprise a protection circuit which automatically resets the flip-flop to the pen down state if a short circuit occurs at the pen solenoid. Transistor Q17 is normally conducting. Its base is biased positive with respect to the emitter by the action of R62 and R59 which form a voltage divider between ground and -7.5 volts. The emitter of Q17 establishes the emitter potential of Q15. Transistor Q15 is normally cut off by the positive bias applied to its base, which is tied to the base of Q16. If a short circuit occurs at the solenoid, Q16 will conduct and its emitter will be at some negative potential determined by the voltage drop across parallel resistors R58 and R60. This causes the bases of both Q16 and Q15 to be driven negative and when the base of Q15 is more negative than the emitter voltage established by Q17, Q15 will conduct. This causes a positive-going pulse to be coupled to the base of Q19, which has the same effect as a pen down signal. The flip-flop is therefore reset to the pen down state and current is cut off from the solenoid. During the short period required for this action to occur, the current through Q16 is limited to 600 ma by the action of R58 and R60.

### 3.2.5 DRUM AND CARRIAGE MANUAL CONTROL CIRCUITS

The manual controls for the drum and carriage control circuits are shown in the schematic diagram of Figure 3-7. Separate controls are provided for single and continuous stepping (fast run) of both the drum and the carriage. Since the drum and carriage controls are identical, only the drum controls will be described in detail.

The DRUM SINGLE STEP switch S7 is a spring-loaded, three-position wafer switch that permits the drum to be manually advanced upward or downward in single steps. In the neutral or off position, shown in Figure 3-7, both the drum up input and the drum down input signal lines to the one-shot multivibrators are returned to -24 volts. The return path for the drum up input is

from pin K of J1, through pin 12 of P3 and J3, through terminal 10 of wafer 7B on switch S7, through terminals 10 and 2 of wafer 8B on switch S8, to the -24 volt bus. The drum down input is returned to -24 volts through a similar path, from pin X of J1. If switch S7 is momentarily turned to the UP position, the drum up manual input line is disconnected from -24 volts connected through terminal 1 of wafer 7B to resistor R8, which is returned to circuit ground through resistor R2. This causes a positive-going pulse to appear at J1-K, which triggers the drum up one-shot multivibrator in the manner described in subsection 3.3.3. Conversely, if S7 is turned to the down position, the drum down manual input at J1-X will be connected to R8 through terminal 9 of wafer 7A, causing the drum down multivibrator to be triggered. The RC network of R8 - R2 - C6 acts as a filter to prevent switching transients from causing double triggering. These components are also connected to the carriage single step circuit associated with switch S5.

The DRUM FAST RUN switch S8 is a detent three-position wafer switch that permits the drum to be continuously stepped in either direction at the rate of 120 steps per second. When the switch is in the neutral or off position, both the drum up and drum down lines are returned to -24 volts through the circuit paths described in the preceding paragraph. If switch S8 is set to the UP position, the drum up input line is disconnected from -24 volts at terminal 2 of wafer 8B and is connected to resistor R4, through terminal 3 of wafer 8B and pin 14 of J3 and P3. Resistor R4 is connected to the unfiltered output of the bridge rectifier circuit, which provides a continuous series of pulses that vary sinusoidally from -40 volts to approximately +4 volts, at the rate of 120 cycles per second. Diode CR5, capacitor C1, and resistor R1 function as a waveshaping circuit. Capacitor C1 charges through CR5 on the negative voltage excursion, and discharges through R1 on the positive excursion. This effectively isolates the fast-run signal line from AC line and switching transients. If switch S8 is set to the DOWN position, the action is identical, except that the drum down input line is connected to resistor R4 through terminal 1 of wafer 8A. Resistor R4 functions as a current limiting and voltage dropping resistor. Resistor R9 performs the same function for the carriage fast run circuit associated with switch S6.

### 3.2.6 PEN SOLENOID MANUAL CONTROL CIRCUIT

The manual control circuit for the pen solenoid is shown in the schematic diagram of Figure 3-7. The

PEN UP/DOWN switch S9 is a spring-loaded three-position wafer switch identical to the DRUM SINGLE STEP and CARRIAGE SINGLE STEP switches S5 and S7. Operation of the switch is the same as for the drum and carriage switches. For example, when switch S9 is momentarily turned to the UP position, then pen up input line at J2-V is disconnected from -24 volts at terminal 10 of wafer 9B and is connected to ground potential at R8, through terminal 1 of wafer 9B.

### 3.2.7 AC POWER DISTRIBUTION AND DC POWER SUPPLY

The Model 563 Digital Incremental Plotter is designed to operate from a source of 115-volt, 50 or 60 cps, single-phase primary power. Power is applied to connector J7 (Figure 3-7) mounted on the rear of the main assembly. One side of the a-c line is routed through a 2 amp fuse F1 and the power ON/OFF switch S3 to a cooling fan B1 and power transformer T1. The other side of the a-c line is connected directly to the fan and the transformer. A front panel indicator lamp DS1 is illuminated whenever switch S3 is ON.

The cooling fan B1, mounted on the power supply sub-assembly, draws air in from the underside of the instrument and directs it over the silicon rectifiers, the step motors, and the chart motors.

Power transformer T1 supplies alternating current to the silicon rectifiers CR1 through CR4, which are connected in a conventional bridge circuit. The bridge rectifier provides a total d-c output voltage of approximately 27 volts. Circuit ground is established at a point 3 volts below the positive side of the output. Filtering is provided by choke L1 and electrolytic capacitors C2 and C3. Diodes CR7, CR8, CR9, CR19, CR11 and CR12, Zener diode CR10, and resistor R3 comprise a voltage divider network across the output. The d-c supply voltages are obtained at +3, +1.5, -7.5, -9, and -24 volt taps on the divider network. Zener diode CR10 provides close regulation of the -7.5 volt supply which is used as a bias reference in the transistor circuits associated with the various control functions. The voltages just specified are ideal and they may vary considerably without any adverse effect on the plotter operation.

Chart take-up motors M1 and M2 are 115-volt two-phase motors which normally operate in a stalled condition to maintain the proper tension on the roll of chart paper. When CHART DRIVE switch S4 is ON, one winding of each motor is connected directly across the a-c line. The second winding of each motor is

connected to the a-c line through phase-shifting capacitors which supply current in the correct phase relationship to produce a torque on the armature. The phase-shifting networks consist of R6 and C8 for the rear take-up motor, and R7 and C9 for the front takeup motor.

To prevent switching transients from feeding back through the power circuits, filtering elements are connected across various components. The contacts of the CHART DRIVE switch S4 are bypassed by R5 and C7, and the POWER switch S3 is bypassed by FL1, located on the base of the plotter nearby the carriage

drive pulley. Capacitor C16 helps suppress transients, originating in the fan motor and power transformer.

All input signals to the Model 563 are connected to the instrument at P5, mounted on the rear of the main chassis. The -24 volt and circuit ground buses from the internal power supply are also terminated at P5 to permit their use as reference potentials in external equipment. Capacitor C5 provides isolation between the circuit ground bus for the Model 563 and the external circuit ground whenever such isolation is required for protection of the equipment. A chassis ground is also provided, at pin 14 of P5.

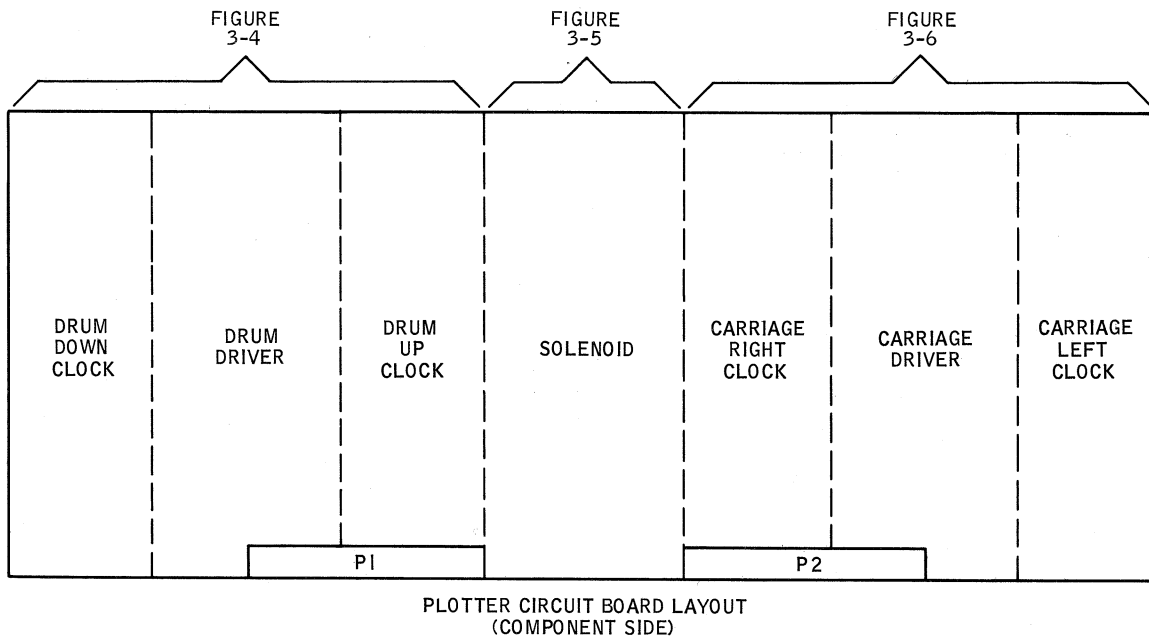

NOTES (FIGURES 3-4, 3-5, AND 3-6)

1. UNLESS OTHERWISE SPECIFIED:  
ALL RESISTOR VALUES ARE IN OHMS +5%, 1/2 WATT  
ALL TRANSISTORS ARE 2N377  
ALL DIODES ARE LD-171, CTP803, OR 1N99  
ALL CAPACITORS ARE 0.01 MF +20% 200V
2. REFERENCE DESIGNATIONS R2, R13, R41, R52, R65, R67, R85, R87, R89, R100, AND R128 ARE NOT USED
3. R11, R50, R72, R80, R98, AND R137 ARE NOT REQUIRED
4. C30 THROUGH C41 ARE LOCATED OUT OF SEQUENCE

FIGURE 3-3  
Circuit Board Layout

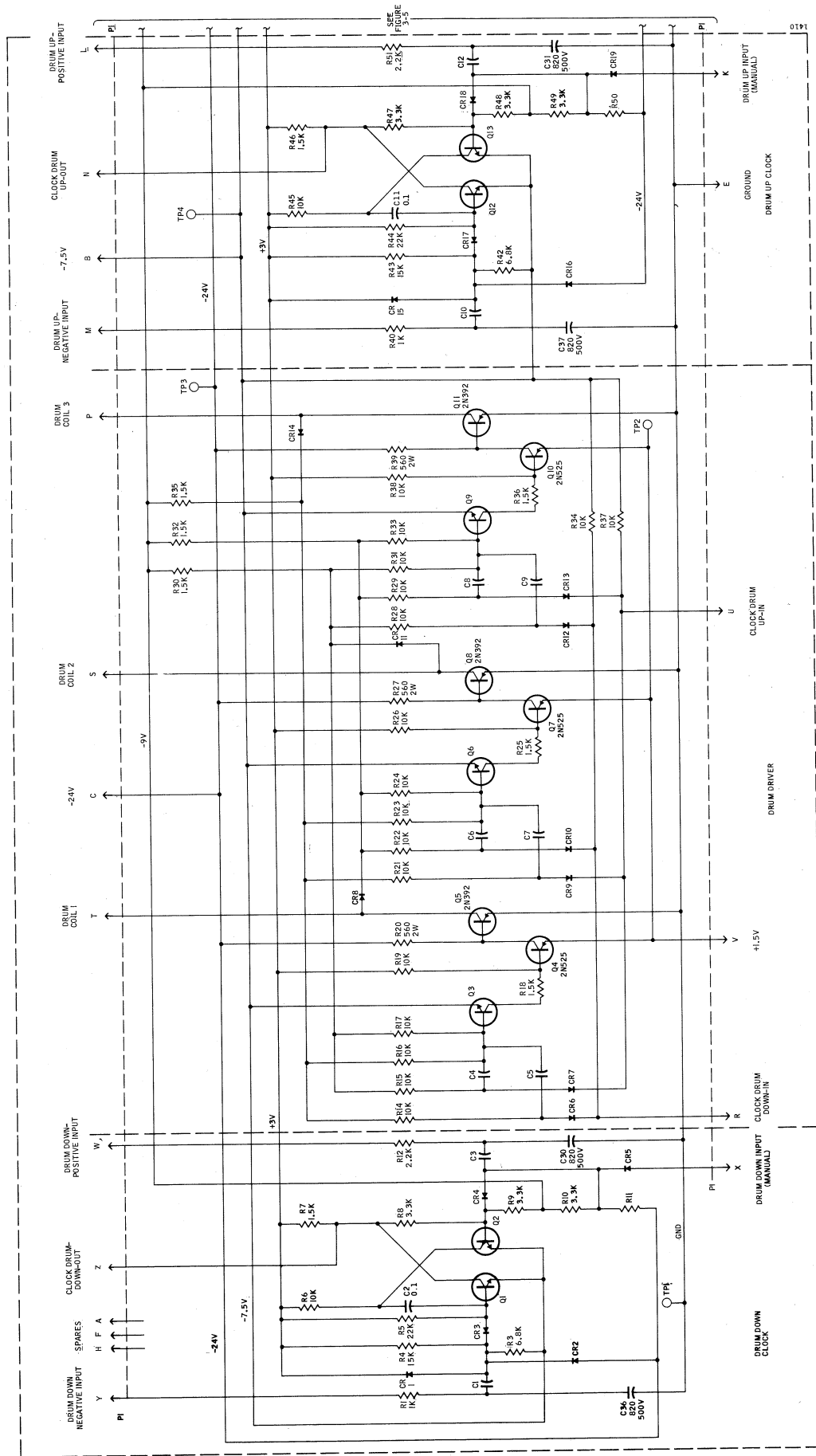

FIGURE 3-4  
Schematic Diagram, Drum Step Motor Control Circuits

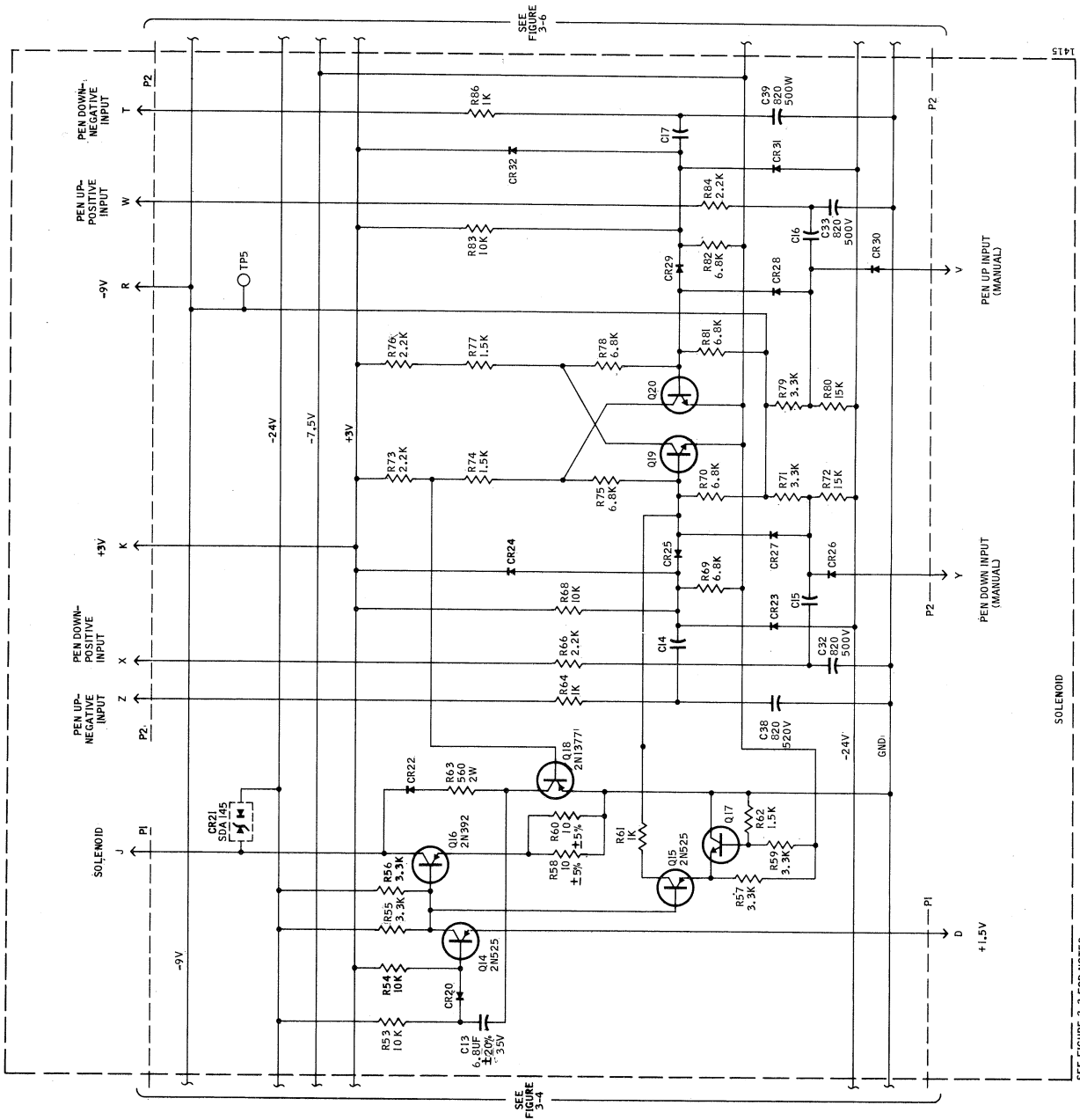

FIGURE 3-5  
Schematic Diagram, Pen Solenoid Control Circuits

SEE FIGURE 3-3 FOR NOTES

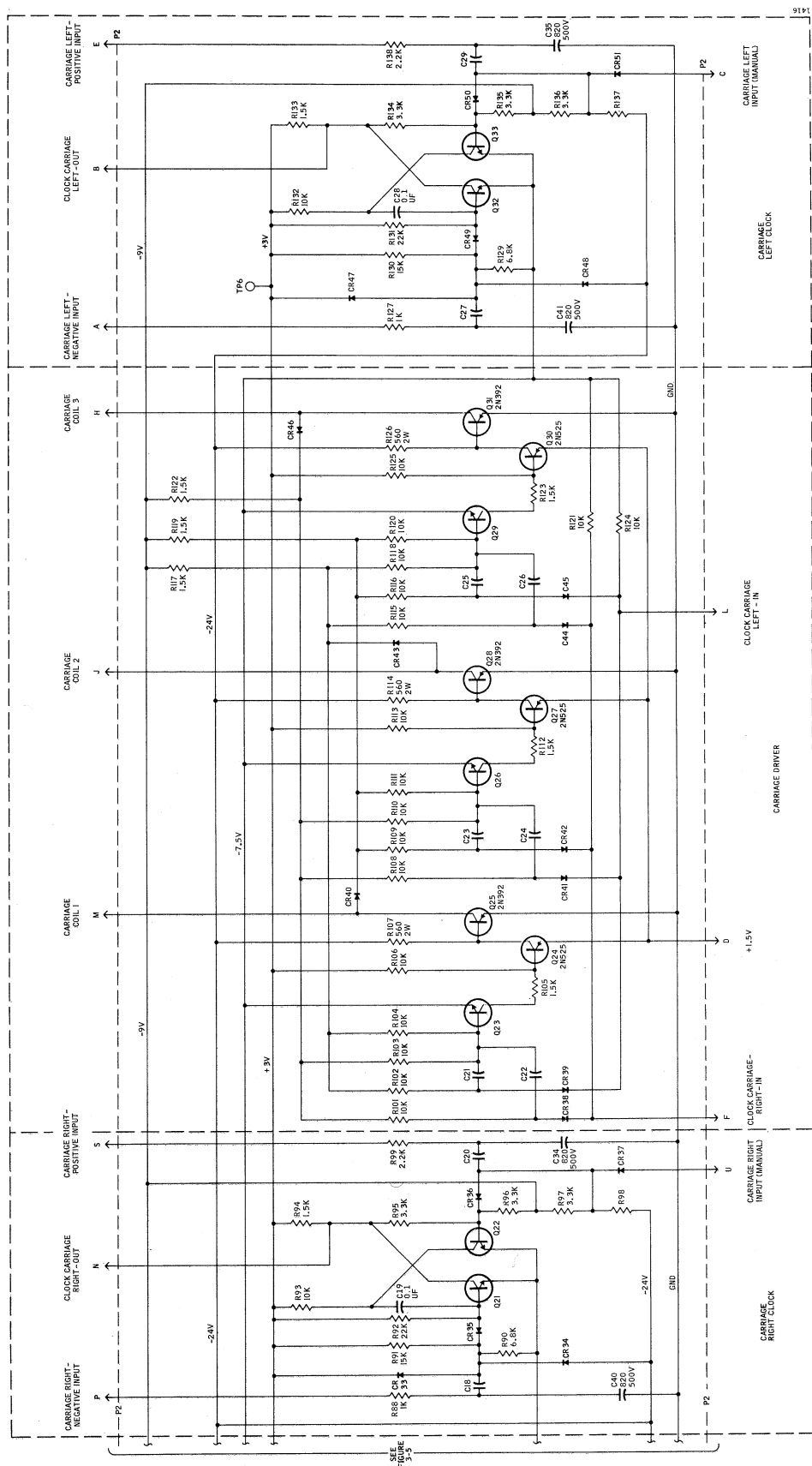
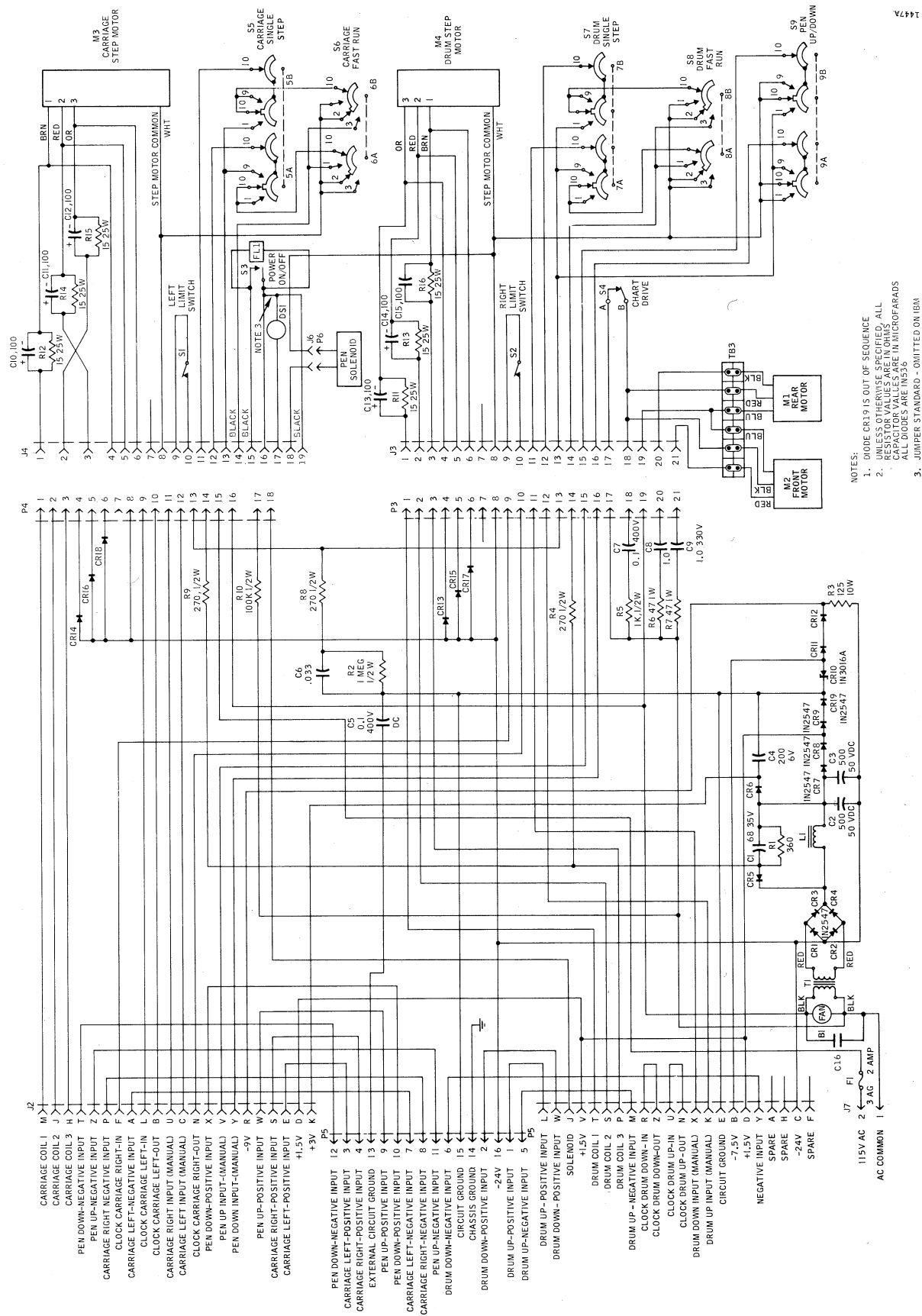

FIGURE 3-6  
Schematic Diagram Carriage Step Motor Control Circuits

SEE FIGURE 3-3 FOR NOTES



- NOTES:
1. BODE CR1.9 IS OUT OF SEQUENCE
  2. UNLESS OTHERWISE SPECIFIED, ALL RESISTOR VALUES ARE IN MICROFARADS ALL DIODES ARE IN536
  3. JUMPER STANDARD - OMITTED ON IBM

FIGURE 3-7  
Schematic Diagram, Main Assembly

## SECTION 4 OPERATING INSTRUCTIONS

### 4.1 INTRODUCTION

This section includes functional descriptions of all front panel controls for the Model 563 Digital Incremental Plotter, instructions for preparation of the plotter for use, and operational checkout procedures. Since operation of the Model 563 is automatic, detailed operating instructions are not required.

### 4.2 CONTROL FUNCTIONS

As shown in Figure 4-1, seven operating controls and one indicator lamp are mounted on the front panel of the instrument. Their functions are described in the following paragraphs.

#### 4.2.1 POWER ON/OFF

The POWER ON/OFF switch connects 115-volt a-c power from connector J7 on the rear panel of the recorder to the cooling fan and the power supply transformer. A neon indicator, located directly below the switch, is lighted when the switch is ON.

#### NOTE

If desired, a-c power to the Model 563 may be supplied through the signal connector P5, utilizing two of the spare pins. If this modification is installed, the two wires connected to J7 should be unsoldered and connected to P5. DO NOT connect jumpers from J7 to P5, since this would result in the presence of ac line voltage on the exposed prongs of J7.

#### 4.2.2 CARRIAGE FAST RUN

The CARRIAGE FAST RUN switch allows the pen carriage to be stepped rapidly to the left or right at the rate of 120 steps per second where using 60 cps power, or 100 steps per second where using 50 cps power. The switch may be used to move the carriage to any desired area of the graph, or for operational checkout of the carriage control circuits and the carriage step motor.

#### 4.2.3 CARRIAGE SINGLE STEP

The CARRIAGE SINGLE STEP switch allows the pen carriage to be moved in single-step increments either to the left or right. This control, in combination with the DRUM SINGLE STEP control, permits the operator to accurately align the carriage on a point or fixed coordinate on the paper.

#### 4.2.4 CHART DRIVE ON/OFF

The CHART DRIVE ON/OFF switch allows the operator to disable the front and rear chart takeup motors. This permits the use of single sheets of chart paper in place of the paper rolls supplied with the instrument.

#### 4.2.5 PEN UP/DOWN

The PEN UP/DOWN switch provides a means of manually raising and lowering the pen from the surface of the drum.

#### NOTE

When the instrument is first turned on, or if the pen is removed and replaced when the plunger is in the PEN UP position, the pen may remain down even when the PEN switch is turned to UP. When this occurs, turn the PEN switch first to DOWN, then to UP. (See Theory of Operation, paragraph 3.2.4.

#### 4.2.6 DRUM FAST RUN

The DRUM FAST RUN switch allows the drum to be stepped rapidly up or down at the rate of 120 steps per second. The switch is used in the same manner as the CARRIAGE FAST RUN control to move the pen to any desired area of the chart, or for operational checkout of the drum control circuits and the drum step motor.

#### 4.2.7 DRUM SINGLE STEP

The DRUM SINGLE STEP switch allows the drum to be moved in single-step increments either up or down. This control, in combination with the CARRIAGE

SINGLE STEP control, permits the operator to accurately align the pen on a point or fixed coordinate on the chart.

#### 4.3 OPERATING PROCEDURES

Operating procedures for the Model 563 consist of loading the chart paper, performing an operational checkout, and aligning the carriage with the zero axis of the chart. These procedures are described in the following paragraphs. After they have been accomplished, the instrument may be connected to the digital signal source for automatic plotting of the desired data.

##### 4.3.1 INSTALLATION OF CHART ROLL

To install a roll of chart paper in the instrument, first make sure that it is evenly wound on the core; i.e., that the ends are not "coned." Straighten coned rolls by tamping the end with the protruding core against a flat surface. Then observe the following points:

- a. Set POWER switch to OFF.
- b. Remove the pen assembly from the carriage by loosening the knurled nut at the bottom of the pen holder and lifting the assembly out of the carriage.

#### CAUTION

Use care not to drop the pen assembly or any of its parts. The assembly is constructed of soft steel to close tolerances, and can be rendered inoperative by nicks or dents.

- c. Rotate the right rear paper spool by hand until the drive key is pointing upward.
- d. Hold the new roll of chart paper so that the key slot in the core is pointing upward. Using your thumb, push the idler spool (left-hand end) to the left, and slip the left-hand end of the roll on the spool. Do not force the idler spool aside with the paper roll, as this tends to cone the end and thus cause misalignment.
- e. Lower the paper roll into the paper well and slide the right end onto the drive spool. Make certain the drive key engages the key slot in the core.
- f. Install a paper roll core on the two front spools below the drum, in the same manner as the paper roll.

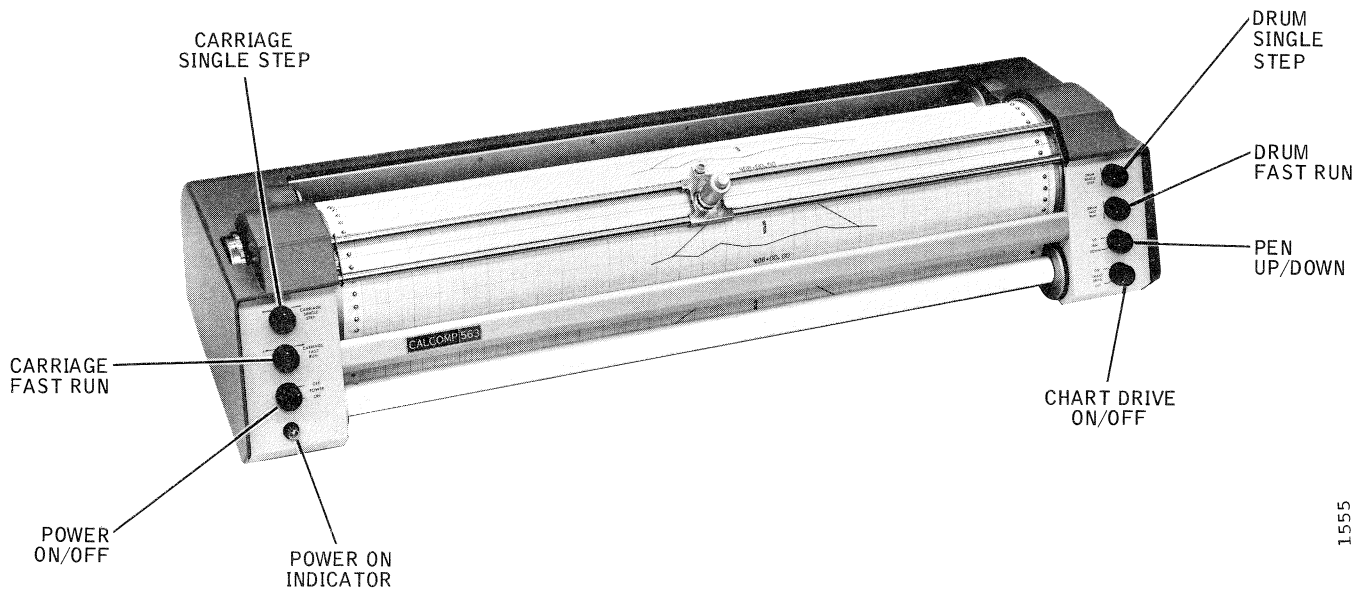

FIGURE 4-1  
Model 563 Control Panel

- g. Pull the end of the paper over the drum so that the sprocket holes on both edges of the paper engage the sprockets on the drum. Guide the chart paper under the carriage rods and behind the tear bar. The chart paper winds on the take-up spool from the back; fasten the end on the spool with scotch tape provided in the accessory kit. Using the DRUM FAST RUN switch, wind a few turns onto the take-up spool.
  - h. Scales on the inside faces of the rear paper spools indicate the approximate amount in feet of paper remaining on the roll. The black scale is for chart papers 0.003 inch thick; the blue scale is for 0.002-inch paper.
- f. Set the CARRIAGE FAST RUN switch to the left position. Check that the pen traces a horizontal line on the chart and that the carriage step motor stops when the carriage reaches its limit of travel. Repeat with the CARRIAGE FAST RUN switch in the right-hand position.
  - g. Alternately operate the CARRIAGE SINGLE STEP and DRUM SINGLE STEP switches. Check that both the carriage and the drum move one step only each time one of the switches is operated.
  - h. Move the carriage near the left margin of the chart paper. Set CARRIAGE FAST RUN switch to the right position and DRUM FAST RUN to down position. Allow the instrument to run until the carriage reaches the right side of its track, then return both switches to off (center) position. Check that the pen traces a 45-degree line on the chart. Check the line carefully for any evidence of discontinuity.

#### 4.3.2 INSTALLATION OF SINGLE SHEET CHART PAPER

Single sheets of chart paper may be used for plotting in place of the chart paper roll. To install a single sheet of chart paper, proceed as follows:

- a. Set POWER and CHART DRIVE switches to OFF.
  - b. Remove the pen assembly from the carriage.
  - c. Slide the chart paper sheet under the carriage rods onto the drum surface.
  - d. Fasten the top edge of the paper to the drum with two or three short pieces of tape. Rotate the drum by hand, keeping the paper smooth and flat against the drum surface. Fasten the bottom edge of the paper in the same manner as the top.
- i. Operate the DRUM SINGLE STEP switch several times to reposition the pen either above or below its position at the end of step h.
  - j. Set CARRIAGE FAST RUN switch to the left position and DRUM FAST RUN switch to the up position. Allow the instrument to run until the carriage reaches the left side of the track, then return both switches to off position. Check that the pen again traces a 45-degree line on the chart and that this line is exactly parallel to the line traced in step h.
  - k. Repeat steps h through j, changing the switch positions to produce two 45-degree lines at right angles to the first two. Again check for discontinuities and make certain the two lines are parallel.

#### 4.3.3 OPERATIONAL CHECKOUT

The following procedure is intended to provide an overall check of the operation of the Model 563 prior to the start of automatic recording. If a malfunction is encountered at any point in the checkout procedure, refer to Section 5 for troubleshooting data.

- a. Install the pen assembly in its carriage.
- b. Set POWER and CHART DRIVE switches to ON.
- c. Set DRUM FAST RUN to UP position. Check that the pen traces a vertical line on the chart paper.
- d. Turn the PEN switch to DOWN, then UP. Check that the pen lifts off the drum surface.
- e. Set the PEN switch to DOWN position, then set the DRUM FAST RUN to DOWN position. Check that the pen again traces a vertical line on the chart paper.

#### 4.3.4 SCALE FACTOR ADJUSTMENT

A carriage travel scale factor adjustment (Figure 4-2) is provided for the purpose of varying the carriage travel to compensate for stretch or shrinkage in the chart paper. The chart paper is printed to a high degree of accuracy under controlled humidity conditions, but is subject to either stretching or shrinking with changes in the relative humidity. In order to maintain the desired accuracy when plotting on preprinted paper that has expanded or shrunk, a scale factor adjustment mechanism is provided on the carriage axis

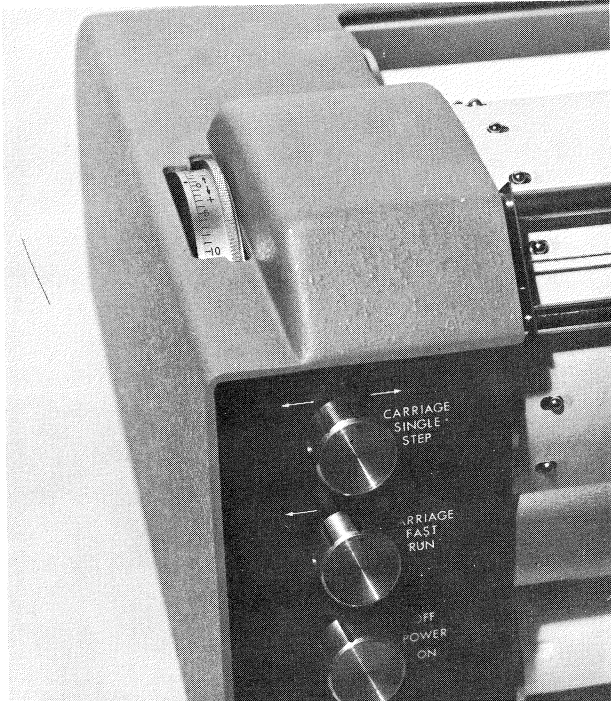

FIGURE 4-2  
Carriage Scale Factor Adjustment

for minutely increasing or decreasing the size of the step to match the grid.

The scale factor adjustment knob projects through the top of the cabinet near the left-hand side. When this knob is set at zero, the carriage travels in 0.010-inch steps, resulting in 29.000 inches of travel for 2900 input pulses. For each division plus or minus on the knob, the total carriage travel of 29 inches will be changed plus or minus 0.010 inch; i.e., plus one division will give a total carriage travel of 29.010 inches for 2900 input pulses, and minus one division will give 28.990 inches. A maximum of plus or minus 30 divisions on the knob provides limits of carriage travel from 28.700 inches to 29.300 inches for 2900 input pulses.

When using preprinted grid paper, the carriage scale factor can be "trimmed" to the grid by measuring the grid on the paper from edge to edge with an accurate steel scale and then setting the proper correction in with the scale factor adjustment knob. (Another method of setting the scale factor adjustment requires

the use of a frequency counter or a test tape. By setting the carriage on the right-hand margin of the chart and applying 2900 input pulses to the carriage drive, the error can be determined by measuring the distance between the left-hand margin and the end of the line. Alternately, the adjustment can be approximated by using some smaller known number of steps from existing plot data.)

When plotting on blank paper, or when constructing grid lines, the scale factor adjustment knob should be set at zero to maintain accurate carriage travel.

#### 4.3.5 RETICLES

Two alignment reticles are provided to permit manual alignment of the carriage to the desired zero point (Figure 4-3). One of these (P/N 20-168) replaces the pen assembly and shows the exact point on which the pen will fall; the other (P/N 20-169) occupies a special receptacle in the carriage, and indicates a point exactly one inch from the pen measured along the X axis in the positive direction. The latter reticle can be left in the carriage at all times. When installing either reticle, rotate it as it is inserted to prevent damage to the 0-ring.

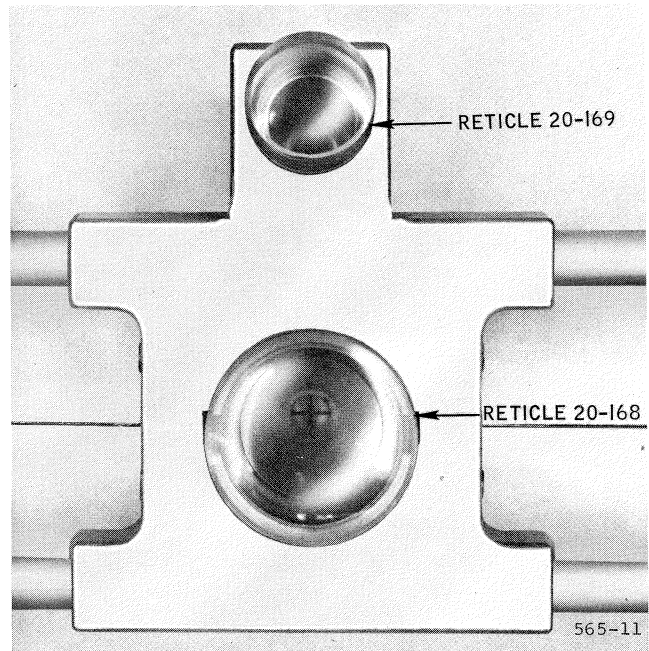

FIGURE 4-3  
Reticle Adjustment

#### 4.3.6 AUTOMATIC OPERATION

After the installation of chart paper, the operational checkout, and the reticle adjustment described in preceding paragraphs, the Model 563 is ready for use. Connect the digital source to P5 on the rear panel of the recorder and set the POWER switch to ON.

#### NOTE

Do not turn power off, then on again, during a recording; this can introduce

a plotting error of one step in any direction.

#### 4.3.7 REMOVAL OF CHART PAPER

The roll of chart paper or single sheet of chart paper should be removed in the reverse sequence to the installation procedure described above. If a single sheet of chart paper is used, any remaining tape adhesive should be cleaned from the drum surface with acetone or a good commercial grade of cleaning solvent.



## SECTION 5 MAINTENANCE

### 5.1 INTRODUCTION

This section includes all necessary instructions for maintenance, troubleshooting and repair of the Model 563 Digital Incremental Plotter. This instrument is constructed of the highest quality materials and the most reliable electronic components. In normal use, with reasonable care, the instrument will provide years of reliable operation with minimum service or repair.

Figures 5-1 and 5-2 show the Model 563 disassembled to the extent required for normal maintenance.

### 5.2 ROUTINE MAINTENANCE

Routine maintenance of the Model 563 is limited to periodic cleaning and operational checkout. Lubrication is limited to the use of a small amount of light grease or vaseline on the threaded portion of the pen carriage to facilitate removal and installation of the pen assembly. Use caution to prevent any lubricant from getting on the electrical spring contacts in the key slots on the carriage.

Since the operational checkout described in Section 4 is normally performed at the start of each recording run, this portion of the routine maintenance schedule may be omitted if the instrument is in frequent use. If the plotter is used infrequently, it is recommended that an operational checkout be performed at least once a week.

The carriage rods, the drum surface, and the metal plunger inside the pen assembly should be cleaned periodically. The intervals at which cleaning should be performed will be determined by the operating environment and the frequency of use. All normal cleaning can be accomplished with a soft, dry cloth. If necessary, the cloth may be moistened with acetone or cleaning solvent to remove foreign matter.

The most common cause of poor quality annotation is dirty carriage rods. It is recommended that rods be cleaned with a dry cloth once every eight hours of operation.

Periodically, a solvent such as alcohol or acetone should be used.

It may be necessary to clean the dirt accumulation from the mating surfaces inside the carriage itself. To do this the cover must be removed from the plotter, and the carriage rods pulled out from one end support and out of the carriage itself. Then a Q-Tip or some similar swabbing device, dipped in alcohol or acetone, can be used to clean the inside of the carriage. The carriage need not be removed from the plotter to do this. However, care should be taken not to give such a pull on the carriage that the spring fastening the ends of the carriage cables is deformed.

The inside of the pen assembly plunger (Figure 5-3) should be cleaned by pushing one corner of the cloth through the center. If the plunger is clogged, it should be dipped in cleaning solvent and then wiped dry, using a Q-Tip to clean the inside of the solenoid.

#### CAUTION

Use care to avoid damage to the Teflon insulation on the carriage drive cable. this cable supplies -24 volt power to the pen solenoid.

### 5.3 DISASSEMBLY

The Model 563 plotter is easily disassembled for maintenance or repair. Normal disassembly is limited to removal of the cover, plotter circuit board, and plug-in power supply. No special instructions are required for removal of individual components on the main assembly, the circuit board, or the power supply.

To disassemble the unit, proceed as follows:

- a. To remove the cover, unscrew eight screws (designated "A" in Figure 5-4) from the base plate.

#### CAUTION

Remove only those screws designated "A" in Figure 5-4. Removal of screws other than those designated "A" will cause mechanical misalignment or damage.

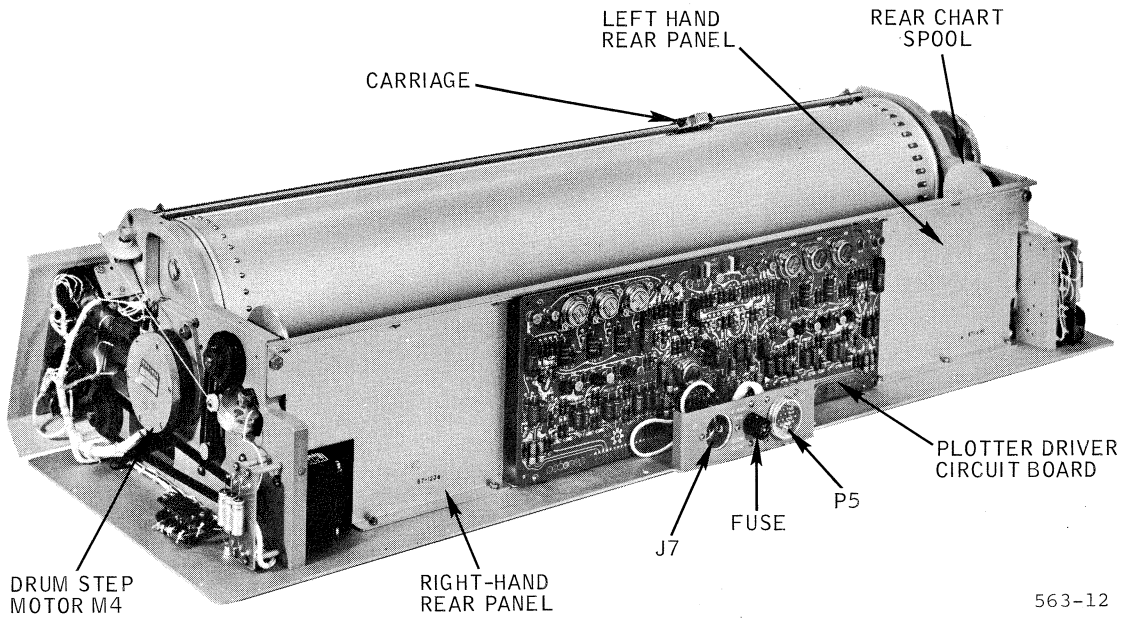

FIGURE 5-1  
Rear Oblique View, Cover Removed

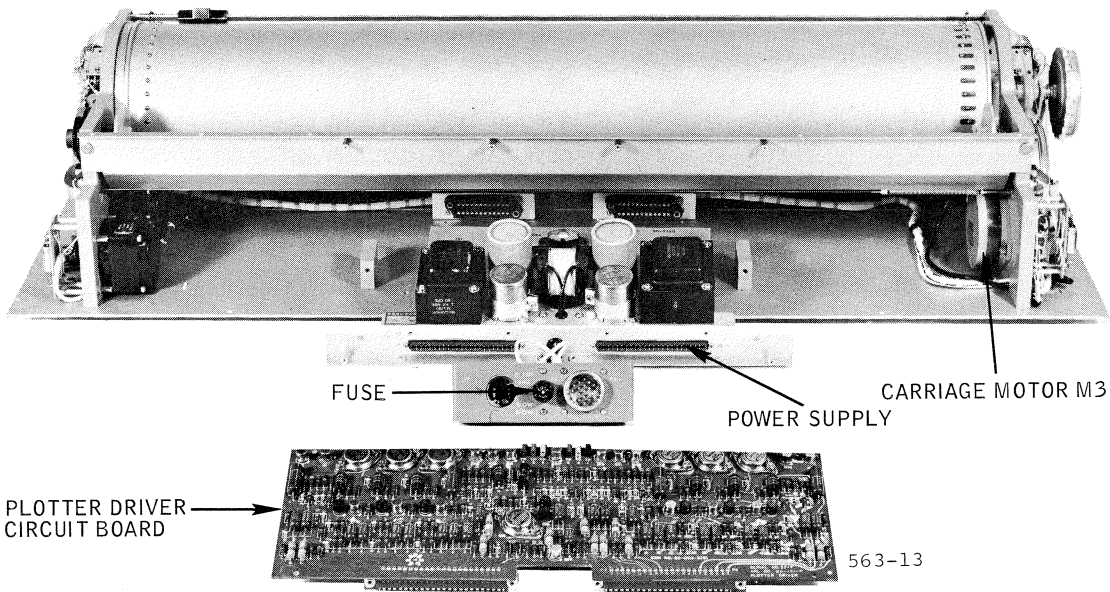

FIGURE 5-2  
Rear View, Plug-In Assemblies Removed

- b. To remove the plotter circuit board, remove six round head screws which fasten the circuit board to mounting standoffs on the main chassis and the power supply chassis. Disengage the assembly from connectors J1 and J2 on the power supply chassis.
- c. To remove the power supply chassis, first unscrew the two binder head screws at "C" in Figure 5-4 which fasten the connector bracket to the rear of the base plate. Next, remove the two hexagon head screws which fasten the extended tabs on the power supply chassis to the base. Then remove five screws (designated "B" in Figure 5-4) from the base plate. The power supply chassis may now be removed by pulling straight back.

#### NOTE

See Section 6 for additional illustrations. Individual circuit components on the circuit board are identified by reference designations printed on the back side of the board (not shown).

#### 5.4 REPLACEMENT AND ADJUSTMENTS

The procedures for replacement and adjustment in the following paragraphs should suffice to keep the plotter operating smoothly under all but the most abnormal circumstances. Adjustments and replacements for which no procedures are given below are either so simple as to be self-evident, or so complex that they should not be attempted in the field.

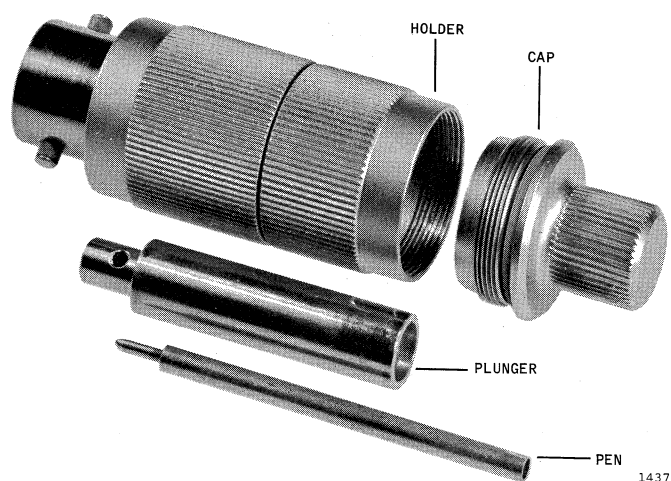

FIGURE 5-3  
Pen Assembly

#### 5.4.1 STEP MOTOR REPLACEMENT AND ADJUSTMENT

Location of the carriage and drum step motors, M3 and M4 respectively, is shown in Figures 5-1 and 5-2. To replace either of the step motors, proceed as follows:

- a. Disconnect power from the instrument. Remove the cover, circuit board, and power supply in accordance with paragraph 5-3.
- b. Clip lacing twine from the step motor leads to separate them from the wiring harness. Remove the orange, red, and brown wires from the three limiting resistors mounted on the side of the main assembly. Note these connections carefully so that the new motor can be connected properly. Disconnect the remaining black wire from the standoff insulator.
- c. Remove the two Allen head cap screws which mount the motor to the main assembly. Lift out the motor and primary gear train.

#### NOTE

The step motor and its primary gear train are matched at the factory and must be replaced as a complete assembly.

- d. Place the new motor and gear train assembly in position, holding the motor so that the protruding pinion gear is below the center axis of the motor.

#### CAUTION

Use care when sliding the motor into position to avoid damaging the plastic gear which mates with the pinion. Do not force the pinion into mesh.

- e. Install, but do not tighten, the two Allen-head cap screws which mount the motor to the main assembly.
- f. Carefully rotate the motor case clockwise until the pinion meshes with the plastic gear. Maintain clockwise pressure while tightening the two cap screws. This will prevent backlash in the gear train.
- g. Rotate the drum or the carriage drive pulley by hand. Either should move freely, but with perceptible resistance. There should be no perceptible backlash when the drum or carriage is

rocked back and forth. If the resistance is excessive, loosen the cap screws and rotate the motor slightly counterclockwise. If backlash is present, rotate the motor slightly clockwise. Again tighten the cap screws.

- h. Connect the lead wires from the new motor to the three resistors and the standoff insulator. Make certain the connections are the same as those on the defective motor removed in step b:
  - Brown - top terminal
  - Red - center terminal
  - Orange - bottom terminal
- i. Lace the motor leads to the wiring harness. If necessary, assemble the power supply and circuit board to the main assembly.
- j. Connect a-c power to the unit and perform the operational checkout in accordance with paragraph 4.3.3. Discontinuities in the 45-degree line, drawn with the CARRIAGE FAST RUN and DRUM FAST RUN controls on, indi-

cates that the motor is skipping steps because of excessive drag. Loosen the cap screws and rotate the step motor slightly counterclockwise. If the operation is excessively noisy, or if the pen overshoots on incremental steps, this indicates backlash. Loosen the cap screws and rotate the motor slightly clockwise.

- k. When checkout is completed satisfactorily, make certain the step motor mounting cap screws are tight, then replace the cover on the unit.

NOTE

For a more accurate check of the step motors, reduce the a-c line voltage to 105vac and connect a square-wave generator to the appropriate pins on P5. The drum and carriage should be capable of continuous stepping action at 300 cps.

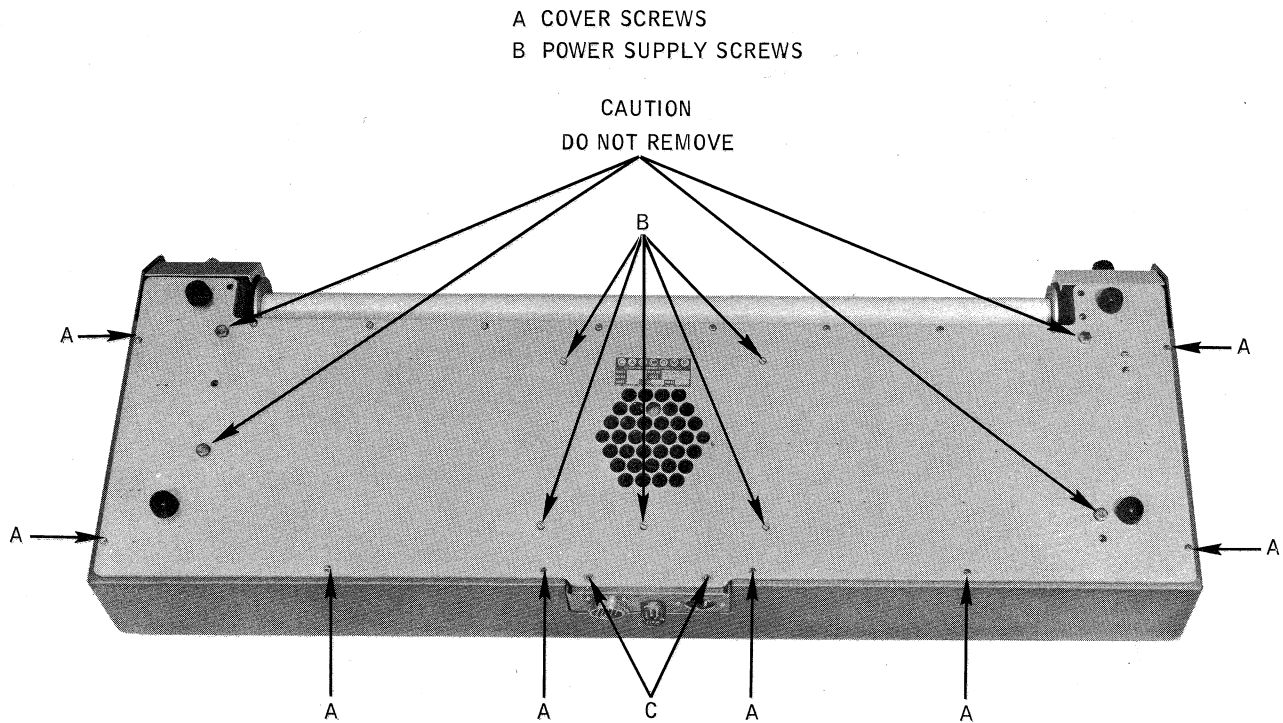

FIGURE 5-4  
Location of Cover and Power Supply Mounting Screws

#### 5.4.2 CARRIAGE CABLE REPLACEMENT

Replacement of a broken or damaged carriage cable can be accomplished in the field with the Carriage Cable Replacement Kit (Part No. 10001-801) available from CalComp. This kit contains all the necessary parts for replacement of all three carriage cables on the CalComp Model 563, 30-inch plotters. However, the individual cable segments may be ordered separately by their corresponding part numbers (refer to Figure 6-1).

The following step-by-step operation describes in detail the procedure for replacing all three carriage cables. While the replacement of these cables can be performed by one man, a two-man operation greatly simplifies the procedure. Unless otherwise specified, all instructions involving directions (left, right, front, and back sides of the plotter) are based on standing in front of and facing the plotter.

#### NOTE

Because much of this procedure must be performed without letting the cables go slack, these instructions should be read through completely and each step visualized before the actual cable replacement is attempted.

As shown in Figure 5-5, the cable segment with the Teflon sleeving over the entire length (part no. 10172-203) is to be connected between the left side of the carriage and the carriage drive pulley. The cable with the Teflon sleeving covering only part of the cable length (part no. 10171-203) is to be connected between the right side of the carriage and the right side of the cable tension spring at the back of the plotter. The completely bare cable (part no. 67-080) is to be connected between the carriage drive pulley and the other side of the cable tension spring. Installation of these three cables is accomplished as follows:

- a. Turn the plotter power off and remove the pen assembly and the plotter cover.
- b. Remove the printed circuit board and power supply as described in paragraph 5.3. Remove also the right- and left-hand rear panels (Figure 5-1).
- c. Loosen the two set screws holding the top carriage rod in place and slide the carriage rod out through one end of the plotter frame. It is not necessary to remove the bottom carriage rod.

- d. Disconnect all cables to be replaced and discard them.
- e. Remove the eyelets loosely mounted on the ends of the two replacement cables which connect to the carriage. This is accomplished by sliding the end of the cable out of the copper Nicopress sleeve. Do not discard the eyelets or sleeves. These will be remounted on the cable later in the procedure.
- f. Connect the cable with the partial Teflon sleeving (part no. 10170-203) to the right side of the carriage and the cable with the full Teflon sleeving to the left side of the carriage. This is accomplished as shown in Figure 5-5 by threading the end of the cable from which the eyelet was removed through the cable retainer, carriage contact spring, and out through the cable access hole in the side of the carriage frame. Pull the cable all the way through until the knotted end of the cable is tight against the inside edge of the carriage frame. Adjust the cable position until the contact spring position matches the formed carriage pen spring permanently fastened to the carriage as shown in Figure 5-5. Pull the cable tight until the cable seats the retainer firmly in the cable access hole and holds the contact spring firmly in place.

#### NOTE

If the cables being replaced are of the old type, which had loops rather than knots on the ends, it will be necessary to remove the two SE-34 eyelets in the carriage before the new cables can be inserted. These eyelets are located at the carriage cable entries, and can be readily extracted by pushing them toward the center of the carriage so that they can be grasped with long-nose pliers or a diagonal cutter and pried out.

- g. Replace the eyelets, previously removed, on the ends of the cable by sliding the Nicopress sleeve back on the cable, looping the cable around the eyelet, and sliding the end of the cable back through the Nicopress sleeve. Continue sliding the cable pigtail through the Nicopress sleeve until the kink in the cable just slides out of the sleeve (approximately five inches of pigtail should be sticking out of the

sleeve). The other side of the cable should then be pulled to tighten the loop around the eyelet. When this is completed, crimp the Nicopress sleeve into place on the cable using a Nicopress Tool No. 17-2 or equivalent and trim off the cable pigtail. Before reinstalling the carriage back on the carriage rod, make sure that the carriage solenoid contacts have not been pushed against the metallic surface of the carriage.

- h. Replace the carriage rod through the endplates, limit switches, and carriage, and retighten the two holding set screws, making sure that they

bottom on the flat surface at each end of the rods. Check to ensure that the partially insulated cable is on the right side of the carriage and the completely insulated cable is on the left side of the carriage.

- i. The section of cable to be installed first is the uninsulated one. Position the carriage drive pulley so that the two notches are at 12 o'clock. Place the metal eyelet over the anchoring stud on the carriage drive pulley and start the anchor nut. Run the cable through the notch that extends to the extreme inside of the pulley, and bend it toward the rear of the plotter at the

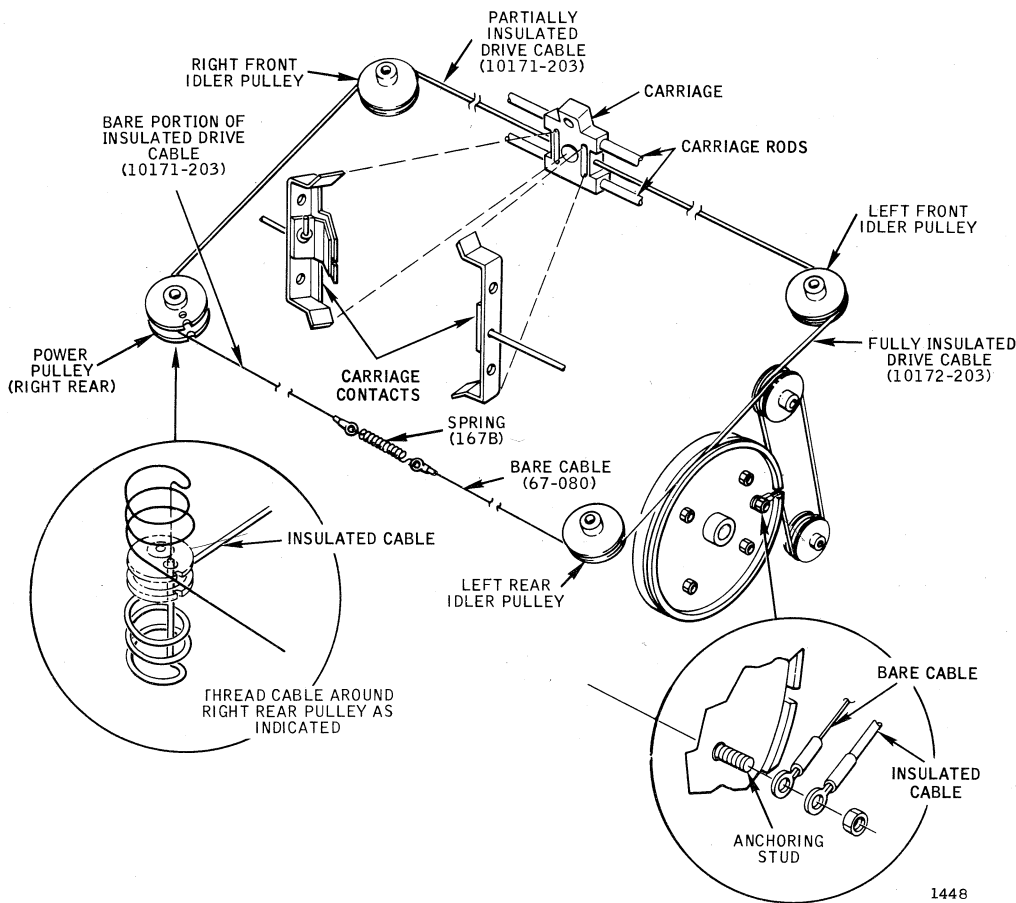

FIGURE 5-5  
Carriage Cable Replacement

point where it passes through the notch. Hold the cable and turn the pulley clockwise, winding the cable on the pulley with the turns progressing away from the center of the plotter. Be sure that the cable turns do not overlap. When the end of the cable is four inches from the drum, secure it with masking tape to the end plate, between the idler pulley and the paper take-up spool mounting nut. The two notches on the carriage drive pulley should then be at about 7 o'clock.

- j. Place the carriage at the extreme right-hand end of its travel and fasten it to the end plate with masking tape. (Do not place the tape on the carriage rods.) Feed the end of the insulated cable from the left-hand side of the carriage through the opening in the carriage limit switch, through the opening in the left end plate, around the left front idler pulley, over the top inside idler pulley, thence under the bottom idler pul-

ley and over the top outside idler pulley, as shown in Figure 5-6. Place a piece of masking tape over the two top idler pulleys to hold the cable in place. Wind the remaining cable counter-clockwise around the drive pulley, working from the middle of the pulley toward the outer flange, and place the eyelet over the anchoring stud, with the cable passing through the smaller of the two notches. Screw the nut on the stud to hold the two eyelets.

- k. Remove the masking tape from the carriage and the right end plate, from across the top surface of the idler pulleys, and from the uninsulated cable held to the left end-plate. Brake the carriage with one hand to prevent the cables already threaded from going slack. Then thread the free end of the uninsulated cable behind the left rear idler pulley, and pull it as far as it will go; i. e., until the carriage is at its left-hand limit of travel. Install the carriage cable

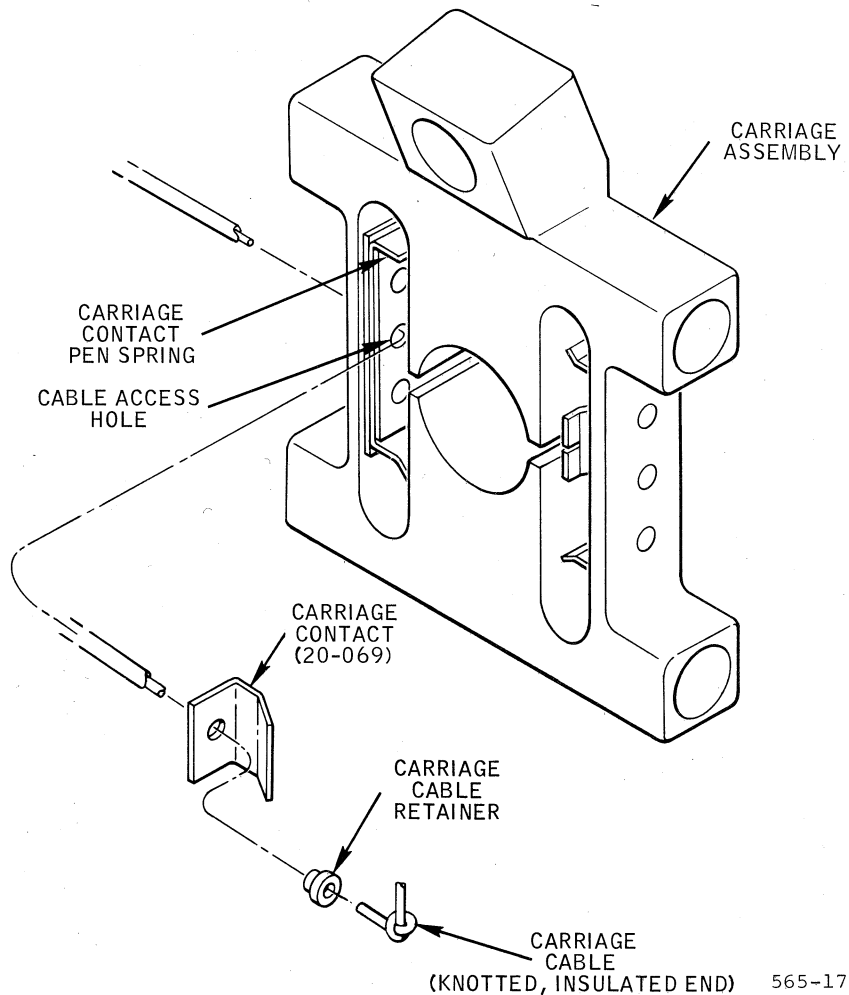

FIGURE 5-6  
Carriage Cable Wiring

tension spring in the Teflon eyelet and bend the end of the spring over so that it cannot slip out of the eyelet. Open the loop on the opposite end of the spring for later ease of installation, and tape the spring to the paper pan to hold the cable taut.

l. Feed the cable extending from the right-hand side of the carriage through the openings in the carriage limit switch and right end-plate, and around the idler pulley. Secure the carriage cable and idler pulley with tape, being careful to see that none of the tape gets on the carriage rods.

m. Find two crimps in the remaining section of cable, one located on the insulated portion of the cable, and the other on the uninsulated portion. Feed the end of the cable through the end plate behind the power pulley, on around the pulley, and out of the end plate at the front of the pulley. The free end of the cable should pass below the standing part. Position the power pulley with the hole located at about five o'clock (as viewed from the top) so that the notch in the lower flange lines up with the crimp in the insulated portion of the cable. String the cable through the notch, under the pulley, and up through the hole in the pulley. Be careful not to twist the cable; it must pass through the hole naturally without kinking.

Position the crimp in the uninsulated part of the cable in the upper notch, and push the turns of cable on the pulley down to the bottom flange. Hold the turns of cable in place on the pulley with the thumb of one hand, and wrap the bare part of the cable clockwise around the pulley, carefully snugging each turn up toward the top flange. Hold the turns at all times so that they cannot unwind while additional turns of cable are made on the pulley. Continue winding until the cable runs out; there should then be ten turns of uninsulated cable around the pulley, and the end should just clear the left-hand side of the plotter. Be careful not to let turns overlap; if any turns are lost or overlapped, or if tension on the cable is lost so that turns become loose, unwind all of the cable on the power pulley and restart the winding at the idler pulley.

n. Continue holding the short length of cable extending out from the power pulley with one hand,

and with the other hand remove the masking tape from the right-hand idler pulley and cable. Then pick up the tension spring and carefully remove the masking tape from the paper pan. Do not let either the cable ends go slack. Pull the uninsulated cable off the power pulley with one hand while maintaining tension on the cable at the tension spring end. Unwind about six inches of cable from the power pulley in this manner, and then refasten the tension spring end of the cable on the paper pan with the masking tape.

o. Again hold the cable turns on the power pulley with the thumb of one hand, and feed the end of the cable one-half turn around the pulley, behind the paper pan, to bring it into position to meet the tension spring. Still keeping tension on the cable, hook the eyelet over the loop of the spring. Crimp the spring loop so the eyelet cannot slip off. Remove any masking tape left on the unit.

p. Gently push the carriage across its full travel two or three times and observe that no turns overlap or bind on any of the pulleys.

q. Once more remove the upper carriage rod. Rotate the carriage on the lower rod so the cable terminations can be seen. Check the retainers, and if they are not firmly seated, move them with a pair of tweezers until they seat properly. Then replace the upper carriage rod.

r. Install the power supply chassis and the printed circuit board. Then check the operation of the scale factor adjustment as described in paragraph 4.3.4.

#### 5.4.3 PAPER FEED ROLL ADJUSTMENT

When the relative humidity varies for extended periods by more than about 10 percent from the recommended 50 percent, the feed drive spool may require adjusting. The adjustment will compensate for expansion or contraction of the paper, which affects the correct alignment of the holes with the drive pins on the drum. To make the adjustment, first remove the cover from the plotter as described in paragraph 5.3, to expose the feed drive spool bearing holder and its set screw (Figure 5-7). Using a 3/32-inch Bristol wrench, loosen the set screw so that the drive spool bearing holder can be turned. Screw the bearing holder in or out with a 7/8-inch end wrench to bring the holes in the paper

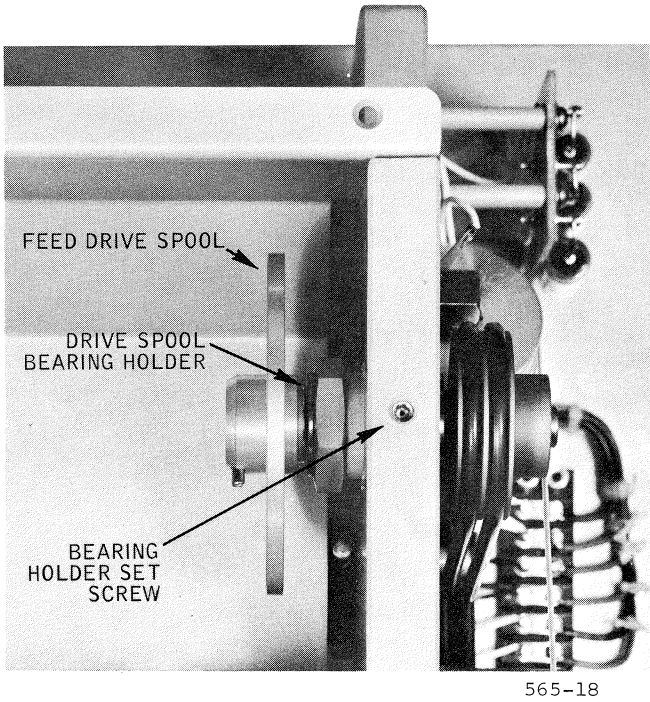

FIGURE 5-7  
Paper Feed Roll Adjustment

into line with the pins. When the roll is correctly adjusted, there should be no tendency of the paper to wrinkle in the area between the roll and the drum surface. Retighten the set screw only enough to keep the bearing holder from turning freely; overtightening can damage the threads on the bearing holder, and will surely mash the nylon ball that is supposed to protect them.

5.4.4 CARRIAGE SCALE FACTOR RECALIBRATION

The scale factor adjustment feature may be checked for accuracy by the following procedure. With the adjustment knob set at zero, draw a short vertical line (x axis) on a piece of chart paper near the right-hand margin. Apply 2900 input pulses to the y axis drive circuit to drive the carriage to the left; use a pulse counter to ascertain the exact number of pulses. At 2900 pulses, draw another vertical pip. Remove the paper from the plotter and measure the distance between the vertical pips with a steel scale. The two pips should be exactly 29.000 inches apart. If an error exists, the mechanism should be readjusted, as follows.

- a. Manually slide the carriage to the right-hand margin, so that it barely touches the right-hand limit switch.
- b. Set the scale factor adjustment knob to zero. If the reference dot is not exactly in line with the zero mark, loosen the three screws holding the reference plate and bring the dot in line with the mark; retighten the screws.
- c. Loosen the nut holding the pinion gear on the carriage drive pulley shaft (A in Figure 5-8) and position the sector gear so that the drive pulley pinion is near the top of the segment; this should place the bottom edge of the sector

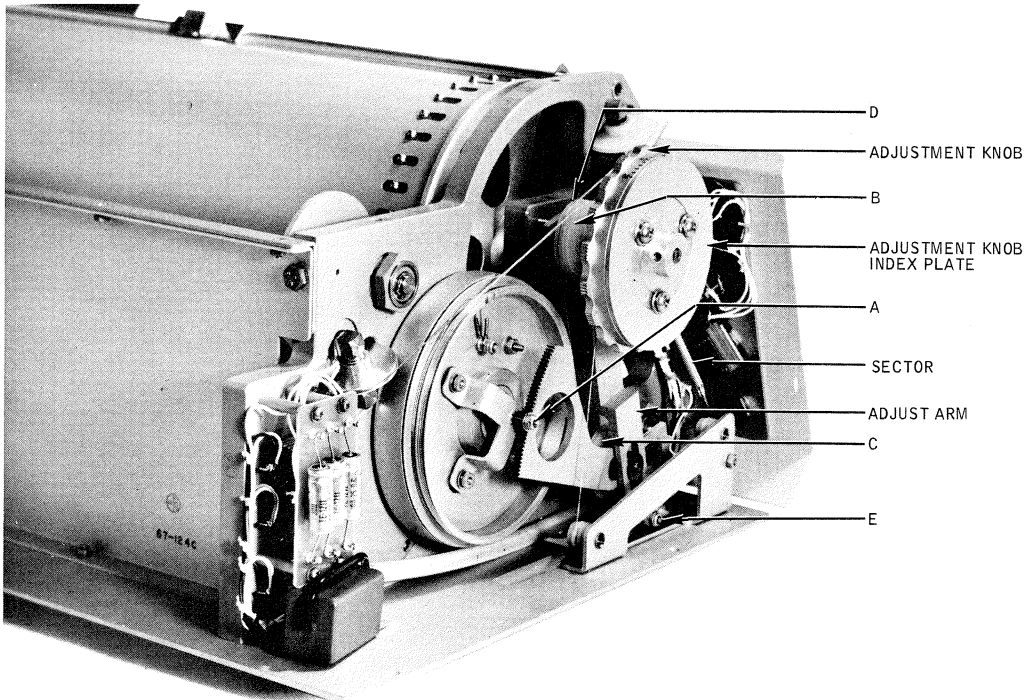

FIGURE 5-8  
Carriage Scale Factor Recalibration

gear parallel to the base of the plotter. Tighten the nut holding the pinion.

- d. Check the position of the lower idler pulley (C in Figure 5-8). If its shaft is not directly in line with the sector pivot shaft, loosen nut E, which clamps the adjust arm to the adjustment knob cable, and move the adjust arm to bring the pulley shaft and the sector gear shaft into line. Then retighten the nut.
- e. Turn plotter power on to prevent the carriage drive pulley from turning.

#### CAUTION

In carrying out the remainder of this procedure use care not to contact exposed terminals and the portions of the carriage drive pulley that carry the pen solenoid current, else you may get shocked.

- f. Observe the two idler pulleys B and D in Figure 5-8, and rotate the adjustment knob through its full calibrated positive and negative travel. If either of the pulleys rotates, set the adjustment knob at zero, loosen nut A to unlock the pinion, move the sector gear slightly, and retighten the pinion.
- g. Again rotate the adjustment knob through its full calibrated range and observe pulleys B and D. If they still rotate, repeat step f, moving the sector gear in the proper direction to reduce the rotation. When no movement is observable, the setting of the pinion is correct.
- h. With the adjustment knob set at zero, repeat the 2900-pulse check described above. If the line drawn is less than 29 inches long, loosen nut E and move the adjust arm slightly toward the rear of the plotter; if the line is more than 29 inches, move the adjust arm slightly toward the front of the plotter. Retighten nut E.
- i. Fine calibration of the scale factor adjust mechanism can be made by rotating the adjustment knob one or two notches and resetting the index plate to match.

## 5.5 TROUBLESHOOTING

The isolation of trouble in the Model 563 plotter requires a comprehensive understanding of the theory of operation described in Section 3. Most troubles can be quickly isolated to one functional circuit by performing the operational checkout described in Section 4. Following this, the trouble can be isolated to a single stage by performing systematic checks to voltages and waveforms. A guide to trouble analysis is given in Table 5-1, while Table 5-2 lists voltage test points and shows typical waveforms.

#### NOTE

Waveforms illustrated in the table may be obtained using the manual FAST RUN controls, or a square wave generator connected to the appropriate pins on P5. The square wave generator must be used to obtain the waveforms shown for the pen control circuits.

No special tools are required for troubleshooting the Model 563. The following test equipment is recommended.

- (1) Laboratory-type oscilloscope
- (2) 20,000 ohm-per-volt multimeter
- (3) Square-wave generator, 600 ohms or less output impedance, less than 5 microseconds rise time, 10 volts output (Hewlett-Packard HP211A or equivalent).

#### CAUTION

Use extreme care when performing tests on the instrument with power on and the cover removed. Accidental short circuits between terminals on the printed circuit board can burn out a diode or transistor. Use care also to avoid shorting the carriage drive cable or its idler pulley to the chassis. Negative 24 volts d-c is present on both the cable and the pulley when power is on.

TABLE 5-1  
Troubleshooting Guide

Symptom	Probable Cause
Unit inoperative; neon power indicator does not light	<ul style="list-style-type: none"> <li>(1) Fuse F1 blown; check for short circuit, then replace fuse</li> <li>(2) Defective POWER switch S3</li> <li>(3) Defective wiring or connector J7</li> </ul>
Unit inoperative; neon power indicator lights	<ul style="list-style-type: none"> <li>(1) Defective power transformer T1</li> <li>(2) Defective power supply component; make voltage and continuity checks; see Figure 3-7</li> </ul>
Both chart drive motors inoperative	<ul style="list-style-type: none"> <li>(1) Defective CHART DRIVE switch S4</li> <li>(2) Defective a-c wiring</li> </ul>
One chart drive motor inoperative	<ul style="list-style-type: none"> <li>(1) Defective motor; check continuity of windings</li> <li>(2) Defective phase-shift component, R6-C8 or R7-C9</li> </ul>
Drum step motor inoperative, carriage operation normal; or carriage motor inoperative, drum operation normal	<ul style="list-style-type: none"> <li>(1) Defective step motor; check continuity of windings</li> <li>(2) Open current-limiting resistor or shorted diode; check continuity; see Figure 3-7</li> <li>(3) Defective drive transistor or ring counter stage; check waveforms per Figure 5-5</li> </ul>
Drum step motor or carriage step motor inoperative in one direction only; operation normal in opposite direction	<ul style="list-style-type: none"> <li>(1) Defective one-shot circuit; check waveforms</li> <li>(2) Defective input trigger circuit; check waveforms and continuity</li> </ul>
Discontinuities in plotting, or inaccurate plotting	<ul style="list-style-type: none"> <li>(1) Improper adjustment of step motor; see paragraph 5.5.1</li> <li>(2) Double stepping due to noise on input signal line; check for excessive power supply ripple; check for defective switching filter components, loose connections, bad solder joints</li> </ul>
Operation normal on automatic plot, abnormal on manual operation	<ul style="list-style-type: none"> <li>(1) Defective control switch or associated wiring</li> </ul>
Operation normal on manual, abnormal on automatic plot	<ul style="list-style-type: none"> <li>(1) Defective input trigger circuit or associated wiring</li> </ul>
Pen control circuit inoperative	<ul style="list-style-type: none"> <li>(1) Defective solenoid; check continuity between key pins on pen assembly</li> <li>(2) Defective flip-flop or current control circuit; check waveforms</li> </ul>

TABLE 5-2  
Voltage Test Points

Voltage	Test Point	Notes
0 vdc	TP1	Circuit ground
- 7.5 vdc	TP4	From -6.1 to -7.8 vdc
- 9.0 vdc	TP5	1.2 volts or more negative with respect to TP4
+ 1.5 vdc	TP2	From +1.7 to +2.2 vdc
+ 3.0 vdc	TP6	From +2.5 to +3.5 vdc
-24 vdc	TP3	From -20 to -25 vdc; no-load ripple less than 4 volts peak-to-peak; load ripple less than 10 volts peak-to-peak

5.5.1 DRUM AND CARRIAGE CONTROL WAVEFORMS

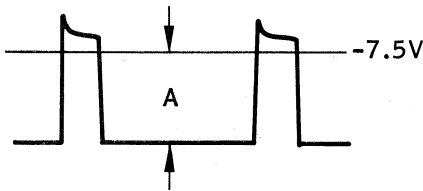

Base of Q2, Q13, Q22, Q33; triangular pad directly below each transistor

One-shot cutoff bias  
Scope: 1 v/cm vertical  
2 ms/cm horizontal  
A = greater than 0.6 volt.

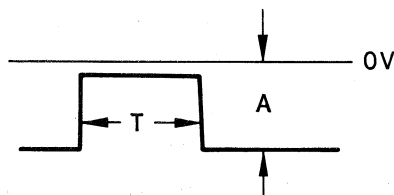

Collector of Q1, Q12, Q21, Q32; top of 1.5K resistor below each transistor

One-shot collector  
Scope: 5 v/cm vertical  
500  $\mu$ s/cm horizontal  
T = 1200 to 1800  $\mu$ sec.  
A = approximately 7 volts

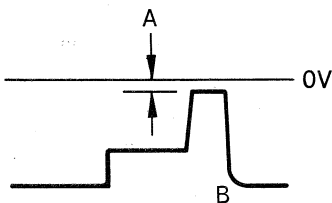

Bottom end of capacitors C4 thru C9, and C21 thru C26 (12 measurements)

Gating waveforms  
Scope: 5 v/cm vertical  
2 ms/cm horizontal  
A = less than 2 volts  
B = no overshoot at this point

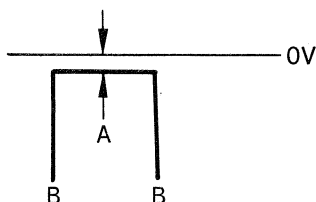

Case (collector) of Q5, Q8, Q11, Q25, Q28, Q31

Power transistor saturation  
Scope: 0.5 v/cm vertical  
2 ms/cm horizontal  
A = less than 0.3 volt  
B = off-scale

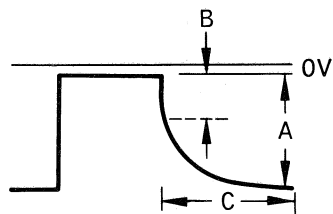

Same as above

Power transistor full waveform  
 Scope: 10 v/cm vertical  
 2 ms/cm horizontal  
 A = approximately 24 volts  
 B = approximately 8 volts  
 C = approximately 5 ms

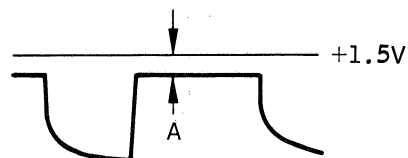

Collector of Q4, Q7, Q10,  
 Q25, Q27, Q30; top of  
 560 ohm 2 watt resistor

Inner stage saturation  
 Scope: 1 v/cm vertical  
 2 ms/cm horizontal  
 A = less than 0.3 volt

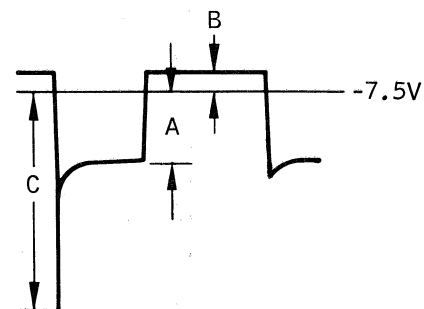

Base of Q3, Q6, Q9, Q23,  
 Q26, Q29

Ring Counter NPN waveform  
 Scope: 1 v/cm vertical  
 2 ms/cm horizontal  
 A = more than 1.0 volt  
 B = less than 0.3 volt  
 C = approximately 6 volts

5.5.2 PEN CONTROL WAVEFORMS

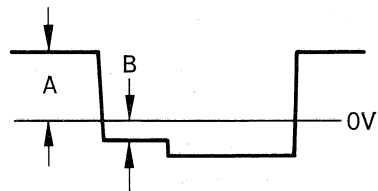

Base of Q18; bottom of  
 1.5K resistor

Q18 cutoff bias  
 Scope: 1 v/cm vertical  
 50 ms/cm horizontal  
 Square-wave generator; 5 cps  
 A = greater than 0.7 volt  
 B = less than 0.3 volt

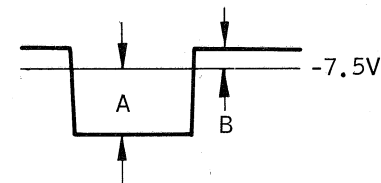

Base of Q19; collector  
 of Q15

Flip-flop saturation  
 Scope: 0.5 v/cm vertical  
 50 ms/cm horizontal  
 Square-wave generator: 5 cps  
 A = greater than 0.7 volt  
 B = less than 0.3 volt

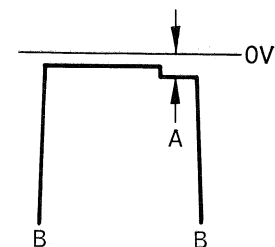

Collector of Q18; top  
 of 560 ohm  
 2 watt resistor

Driver saturation  
 Scope: 0.5 v/cm vertical  
 50 ms/cm horizontal  
 Square-wave generator: 5 cps  
 A = less than 0.3 volt  
 B = off scale

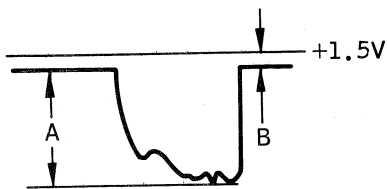

Collector of Q14; top of  
3.3K resistors below  
560 ohm resistor

Q14 collector voltage  
Scope: 1.0 v/cm vertical  
20 ms/cm horizontal  
Square-wave generator: 5 cps  
A = approximately 3 volts  
B = less than 0.3 volt

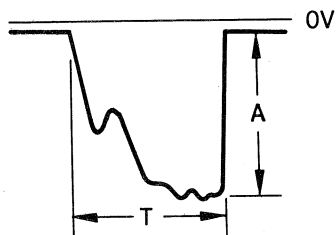

Top of 10 ohm resistors  
R58 and R60

Driver current waveform  
Scope: 0.5 v/cm vertical  
20 ms/cm horizontal  
Square-wave generator: 5 cps  
T = 40 to 60 ms  
A = greater than 0.8 volt

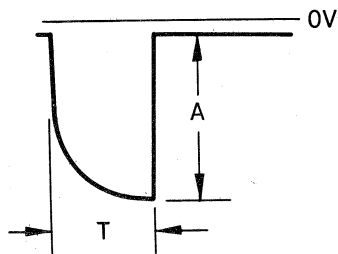

Same as above

Driver short-circuit current  
Scope: 1.0 v/cm  
50  $\mu$ sec/cm  
Square-wave generator: 5 cps  
Short out CR21 to obtain wave-  
form; when short is removed,  
waveform should be same as that  
shown above and pen should lift  
and lower normally  
T = less than 100  $\mu$ sec  
A = approximately 3.5 volts

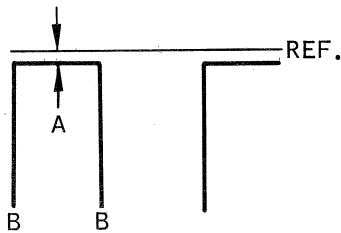

Case (collector) of Q16

Driver saturation  
Scope: 0.5 v/cm vertical  
20 ms/cm horizontal  
Square-wave generator: 5 cps  
Ref: ungrounded end of R58-R60  
A = less than 0.3  
B = off scale

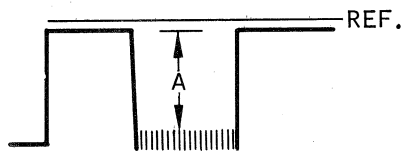

Same as above

Driver full waveform  
Scope: 10 v/cm vertical  
50 ms/cm horizontal  
Square-wave generator: 5 cps  
Ref: same as above  
A = approximately 24 volts

## SECTION 6 PARTS LIST

This section provides a listing of all detail parts in the Model 563 Digital Incremental Plotter. Replacement parts can be obtained from the manufacturer at the following address:

California Computer Products, Inc.  
Marketing Department  
305 North Muller Avenue  
Anaheim, California 92803

When ordering replacement parts, give the complete description as listed in this section, together with the part number. Vendor items may be obtained either from California Computer Products, Inc., or from the vendor. Commercial items can usually be obtained from any electronic parts distributor.

The step motor, drum assembly, and carriage drive pulley combinations for machines of various step sizes are shown below in Table 6-1. Part numbers for various accessory items and loose equipment are listed in Table 6-2.

### CAUTION

DO NOT attempt to change step sizes by interchanging step motors. The entire gear train can be severely damaged if a step motor is replaced by one bearing a different part number.

TABLE 6-1  
Part Numbers Dependent on Step Size

Plotter Step Size	Plotter Part No.	Step Motors (31)	Drum Ass'y (37)	Carriage Drive Pulley Ass'y (26)
0.010 in.	67-002	Drum: 20-100 Carr: 58-100	67-129	67-098
0.005 in.	10005-101	10001-301	10018-203	10019-203
0.10 mm	10012-101	10001-301-11	10018-203-11	10019-203-11

TABLE 6-2  
Loose Equipment

Item	Part No.	Quantity
Ball point pen kit	10082-101	1
Line cord	10069-401	1
Cable connector	SK-19-21C-1/2	1
Plotter cover (large)	10306-203-21	1
Paper roll core	67-147	1
Roll of chart paper	302 O. B.	1
Roll of chart paper	302 Red	1
Roll of chart paper	300	1
Instruction manual	10017-901-003	2

FIGURE AND INDEX NUMBER	PART NUMBER	DESCRIPTION						MANUFACTURER	UNITS PER ASSY.
		1	2	3	4	5	6		
6-1	See Table 6-1	DIGITAL INCREMENTAL PLOTTER, Model 563						CalComp	1
- 1	5100-18	• RING, Snap						Truarc Retaining Rings, Div. Waldes Kohinoor Inc., Long Island City, N. Y.	3
- 2	67-009	• ROD, Carriage						CalComp	2
- 3	67-104	• CARRIAGE SUBASSEMBLY						CalComp	1
- 4	67-014	• PULLEY, Paper roll take-up						CalComp	2
- 5	568-145DBA	• 0-RING						Plastic & Rubber Prod. Co. Los Angeles, Calif.	2
- 6	67-183	• PULLEY, Idler						CalComp	2
- 7	568-161DBA	• 0-RING						Plastic & Rubber Prod. Co. Los Angeles, Calif.	2
- 8	20-026	• SUPPORT, Idler pulley shaft						CalComp	4
- 9	Coml	• NUT, 6-32, CRES						All Metal Garden City, N. Y.	8
-10	AN936A6	• WASHER, Lock							4
-11	AN960C6	• WASHER, Plain							4
-12	2150	• WASHER, Fiber						Smith, H. H. Co. Brooklyn, N. Y.	8
-13	5708	• LUG						CalComp	4
-14	67-188	• WASHER						CalComp	4
-15	67-064	• WASHER, Spring						CalComp	4
-16	20-029	• SHAFT						CalComp	2
-17	20-099	• PULLEY, Idler subassembly						CalComp	1
-18	67-128	• PULLEY, Special idler subassembly						CalComp	1
-19	Coml	• SET SCREW, Socket head, 10-32x1/4 Cup point, steel						All Metal, Garden City, N. Y.	5
-20	Coml	• BALL, Nylon, 5-32 dia						Ed Maltby & Co. Los Angeles, Calif.	4
-21	5100-31-H	• RING, Snap						Truarc Retaining Rings, Div. Waldes Kohinoor Inc. Long Island City, N. Y.	2
-22	20-106	• HOLDER, Bearing						CalComp	4
-23	20-033	• SPRING, Paper roll idler spool						CalComp	2
-24	67-102	• IDLER SPOOL, Paper roll						CalComp	2
-25	167B	• SPRING, Cad plated						Lane Spring Co. Los Angeles, Calif.	1
-26	See Table 6-1	• DRIVE PULLEY SUBASSEMBLY						CalComp	1
-27	5100-50-H	• RING, Snap						Truarc Retaining Rings, Div. Waldes Kohinoor Inc. Long Island City, N. Y.	1
-28	67-153	• GEAR, Pinion						CalComp	1
-29	20-077	• SHAFT						CalComp	1
-30	20-109	• WASHER, Spring						CalComp	3
-31	See Table 6-1	• STEP MOTOR SUBASSEMBLY, M3, M4						CalComp	2
-32	RH25	• RESISTOR, 15 ohm, 2 w, R11 thru R16						Dale Products Columbus, Nebraska	6
-33	V3-47	• SWITCH, S1, S2						Microswitch Div. Minneapolis Honeywell Inc., Freeport, Illinois	2
-34	20-150	• CIRCUIT BOARD ASSEMBLY, Plotter Driver, See Figure 6-6 for detail breakdown						CalComp	1
-35	BH-2096W	• BUMPER, Rubber						Accurate Rubber & Plastic Co. Santa Monica, Calif.	4
-36	67-027	• MOTOR, Subassembly						Bristol Motors, Los Angeles, Calif.	2
-37	See Table 6-1	• DRUM ASSEMBLY						CalComp	1
-38	A4050	• BEARING, Class No. 3						Timken Roller Bearing Co. Canton, Ohio	2
-39	20-074	• BRACKET, Connector, power supply						CalComp	2
-40	20-131	• POWER SUPPLY ASSEMBLY, Digital incremental plotter, see Figure 6-2 for detail breakdown						CalComp	1

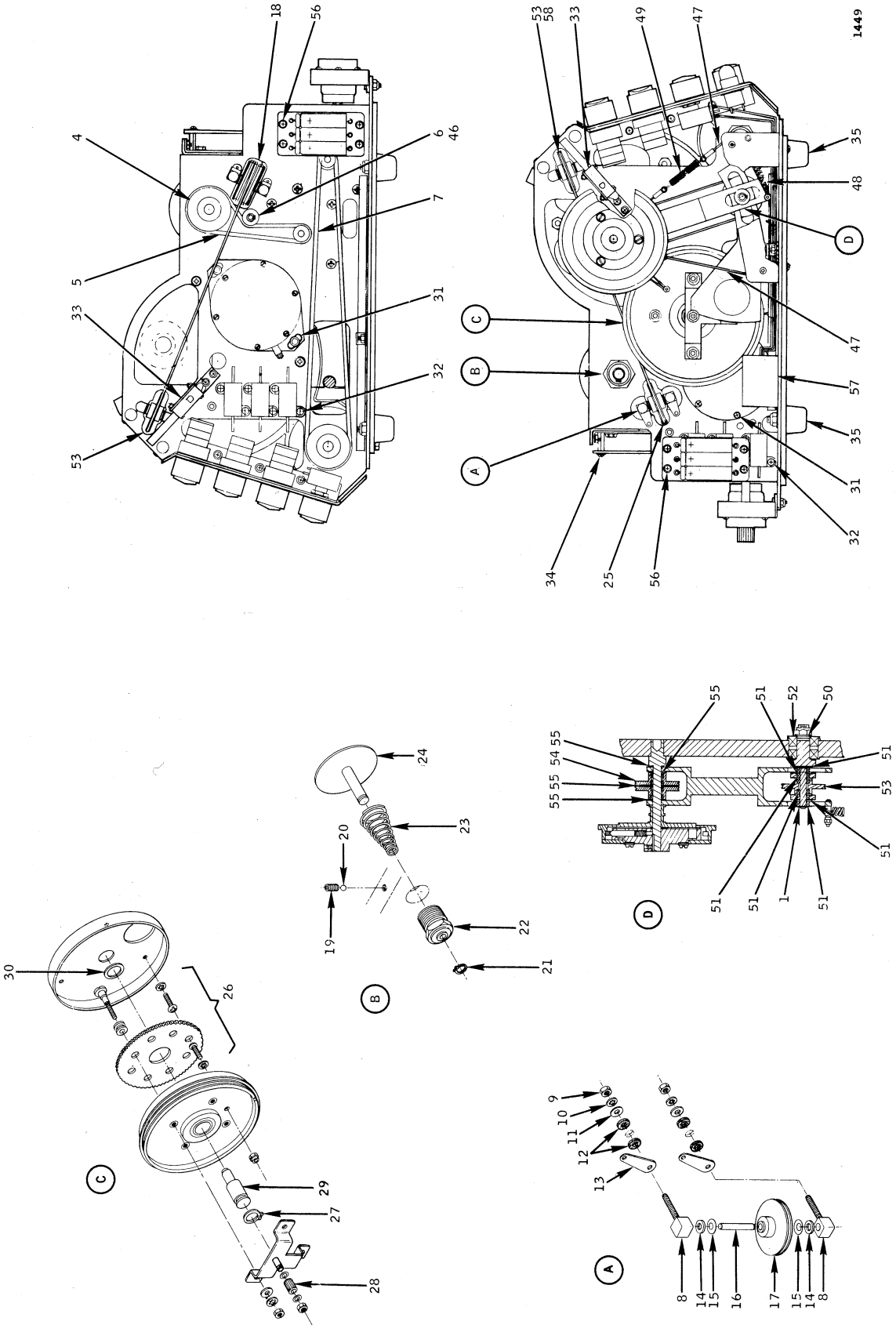

1449

FIGURE 6-1  
Main Assembly, Location of Parts

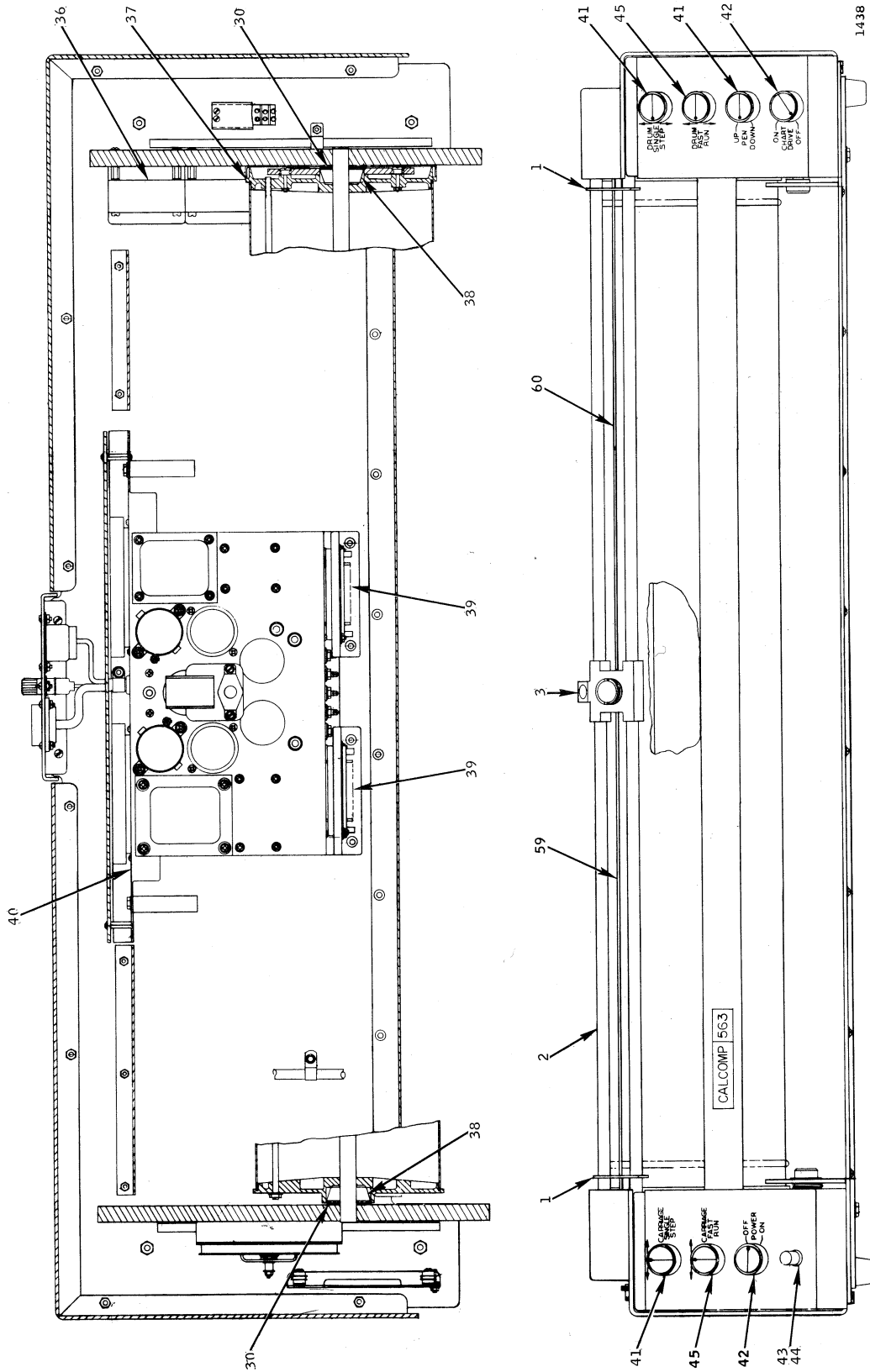

FIGURE 6-1  
Main Assembly, Location of Parts (Continued)

FIGURE AND INDEX NUMBER	PART NUMBER	DESCRIPTION						MANUFACTURER	UNITS PER ASSY.
		1	2	3	4	5	6		
-41	24102	• SWITCH, Single Step & Pen, S5, S7, S9						Grayhill, Inc. La Grange, Ill.	3
-42	20-111	• SWITCH, Power and Paper, S3, S4						CalComp	2
-43	145-5036-997	• LAMP ASSEMBLY						Dialight Corp. Brooklyn, N. Y.	1
-44	NE-2D	• LAMP, Neon						Dialight Corp. Brooklyn, N. Y.	1
-45	5-002-3	• SWITCH, Fast Run, S6, S8						Grayhill, Inc. La Grange, Ill.	2
-46	5100-12	• RING, Snap						Truarc Retaining Rings, Div. Waldes Kohinoor Inc. Long Island City, N. Y.	1
-47	67-186	• CABLE						CalComp	1
-48	67-189	• SPRING						CalComp	1
-49	167A	• SPRING						Lane Spring Co. Los Angeles, Calif.	1
-50	67-149	• WASHER						CalComp	1
-51	5700-8-15	• WASHER						Seastrom Mfg. Co. Glendale, Calif.	5
-52	AFS3KDD	• BEARING						Fafnir Bearing Co. New Britain, Conn.	2
-53	67-159	• PULLEY, Idler						CalComp	3
-54	67-161	• PULLEY, Idler						CalComp	2
-55	5700-16-15	• WASHER						Seastrom Mfg. Co. Glendale, Calif.	7
-56	67-125	• BOARD ASS'Y, see Figure 6-5 for detail breakdown						CalComp	2
-57	11386-203	• R/C NETWORK FL1						CalComp	1
-58	67-080	• CABLE						CalComp	1
-59	10172-203	• CABLE						CalComp	1
-60	10171-203	• CABLE						CalComp	1

FIGURE AND INDEX NUMBER	PART NUMBER	DESCRIPTION						MANUFACTURER	UNITS PER ASSY.
		1	2	3	4	5	6		
6-2	20-131	POWER SUPPLY ASSEMBLY, Digital incremental plotter, see Figure 6-1-40 for next higher assembly						CalComp	Ref
- 1	20-035	• CHASSIS						CalComp	1
- 2	20-142	• TERMINAL BOARD ASSEMBLY, No. A, power supply TB1, see Figure 6-3 for detail breakdown						CalComp	1
- 3	20-141	• TERMINAL BOARD ASSEMBLY, No. B, power supply TB2, see Figure 6-4 for detail breakdown						CalComp	1
- 4	7486	• CONNECTOR, Electrical, J7						Harvey Hubbell Inc. Bridgeport, Conn.	1
- 5	313002	• FUSE, 3AG, 2AMP slo-blo, F1						Littlefuse Inc. Des Plaines, Illinois	1
- 6	342004	• HOLDER, Fuse						Littlefuse Inc. Des Plaines, Illinois	1
- 7	SK19-32SL	• CONNECTOR, Electrical, P5						Cannon Electric Co. Los Angeles, Calif.	1
- 8	0-429-4	• FAN						Torrington Mfg Torrington, Conn.	1
- 9	1N2547	• SEMICONDUCTOR DEVICE, Diode, CR1 thru CR4, CR7 thru CR9, CR19						Bradley Semiconductor Corp. New Haven, Conn.	8
-10	910009-403	• TRANSFORMER, T1						CalComp	1
-11	WP065	• CAPACITOR, 500 mfd, 50 vdc, C2, C3						Mallory & Co. Indianapolis, Indiana	2
-12	RP3301	• CAPACITOR, 1.0 mfd, 330 vac, C8, C9						Mallory & Co. Indianapolis, Indiana	2
-13	35010-1	• MOTOR, Model F-5, CCW, B1						The General Industries Co., Elyria, Ohio	1
-14	910008-403	• CHOKE, L1						CalComp	1
-15	26-159-24	• CONNECTOR, Electrical, P3, P4						Amphenol Electronics Corp., Chicago, Illinois	2
-16	143-022-01	• CONNECTOR, Electrical, J1, J2						Amphenol Electronics Corp., Chicago, Illinois	2
-17	PVC601	• CAPACITOR, 0.1 mfd, 600 V, C16						Mallory & Co. Indianapolis, Indiana	1

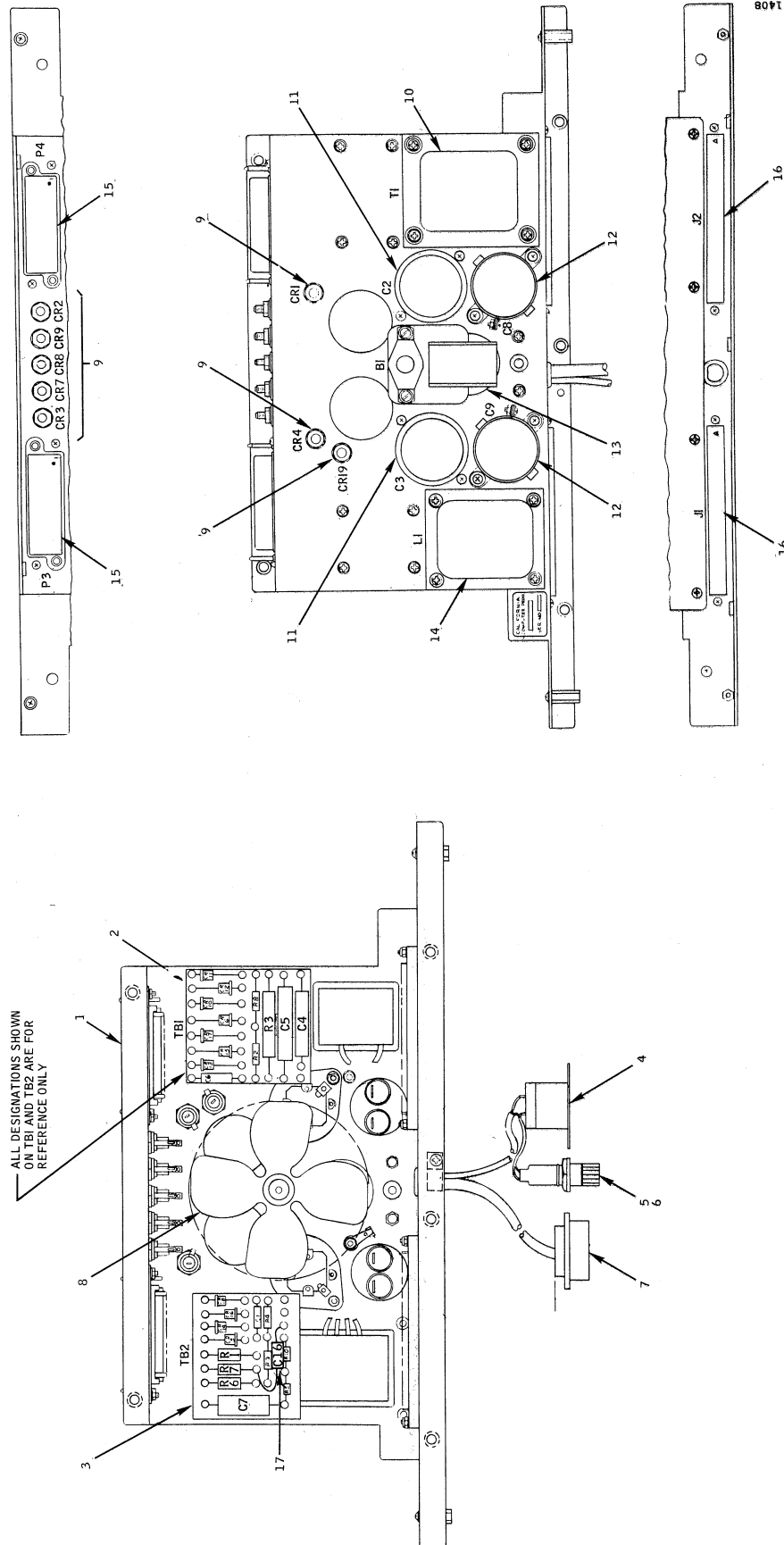

FIGURE 6-2  
Power Supply Assembly

FIGURE AND INDEX NUMBER	PART NUMBER	DESCRIPTION						MANUFACTURER	UNITS PER ASSY.
		1	2	3	4	5	6		
6-3	20-142	TERMINAL BOARD ASSEMBLY No. A power supply, TB1, see Figure 6-2-2 for next higher assembly						CalComp	Ref
- 1	65P33302	• CAPACITOR, 0.033 mfd, $\pm 20\%$ , 200 VDC, C6						Sprague Electric Co. North Adams, Mass.	1
- 2	1N536	• SEMICONDUCTOR DEVICE, Diode CR6, CR11 thru CR13, CR15, CR17						General Electric Co. Syracuse, N. Y.	6
- 3	1N3016A	• SEMICONDUCTOR DEVICE, Diode Zener, CR10						International Rectifier Corp. El Segundo, Calif.	1
- 4	EB2711	• RESISTOR, 270 ohm, $\pm 10\%$ , 1/2 w, R8						Allen Bradley, Milwaukee, Wis.	1
- 5	10XM125	• RESISTOR, 125 ohm, $\pm 5\%$ , 10w, R3						Ward Leonard Co. Mount Vernon, N. Y.	1
- 6	4TM-P10	• CAPACITOR, 0.1 mfd, $\pm 10\%$ , 400 v, C5						Sprague Electric Co. North Adams, Mass.	1
	109P10404	• CAPACITOR, 0.1 mfd, $\pm 10\%$ , 400 v, C5, alternate and interchangeable with Part No. 4TM-P10						Sprague Electric Co. North Adams, Mass.	Ref
- 7	30D137A1	• CAPACITOR, 200 mfd, 6 VDC, C4						Sprague Electric Co. North Adams, Mass.	1
	TE1104	• CAPACITOR, 200 mfd, 6 vdc, C4, Alternate and interchangeable with Part No. 30D137A1						Sprague Electric Co. North Adams, Mass.	Ref
- 8	EB1051	• RESISTOR, 1 meg, $\pm 10\%$ , 1/2 w, R2						Allen Bradley, Milwaukee, Wis.	1
- 9	20-072	• BOARD, Terminal, No. A						CalComp	1

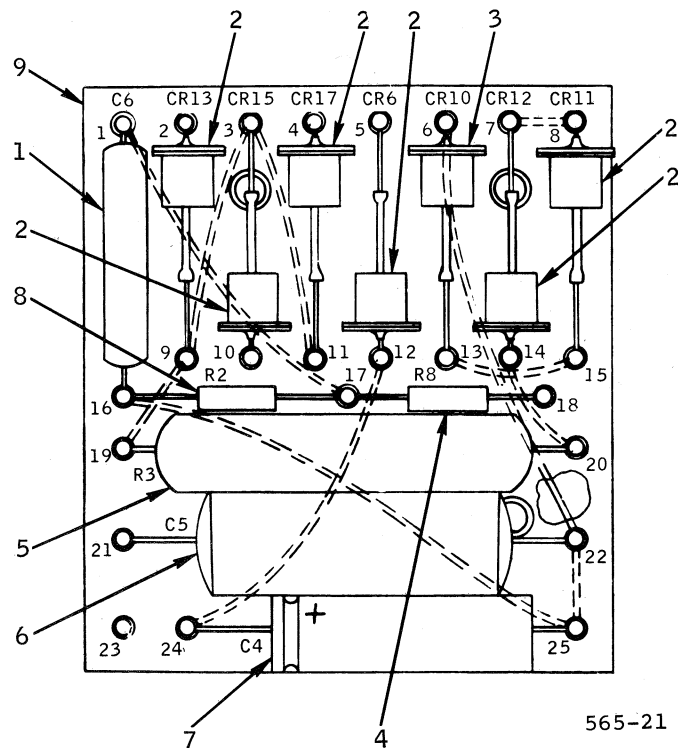

FIGURE 6-3  
Terminal Board Assembly



FIGURE AND INDEX NUMBER	PART NUMBER	DESCRIPTION						MANUFACTURER	UNITS PER ASSY.
		1	2	3	4	5	6		
6-5	67-125	TERMINAL BOARD ASSEMBLY						CalComp	Ref
- 1	TE-1211	See Figure 6-1-56 for next higher assembly. • CAPACITOR, 100 mfd., 25v						Sprague Electric Co. North Adams, Mass.	3

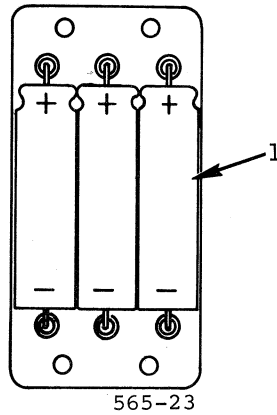

FIGURE 6-5  
Terminal Board Assembly

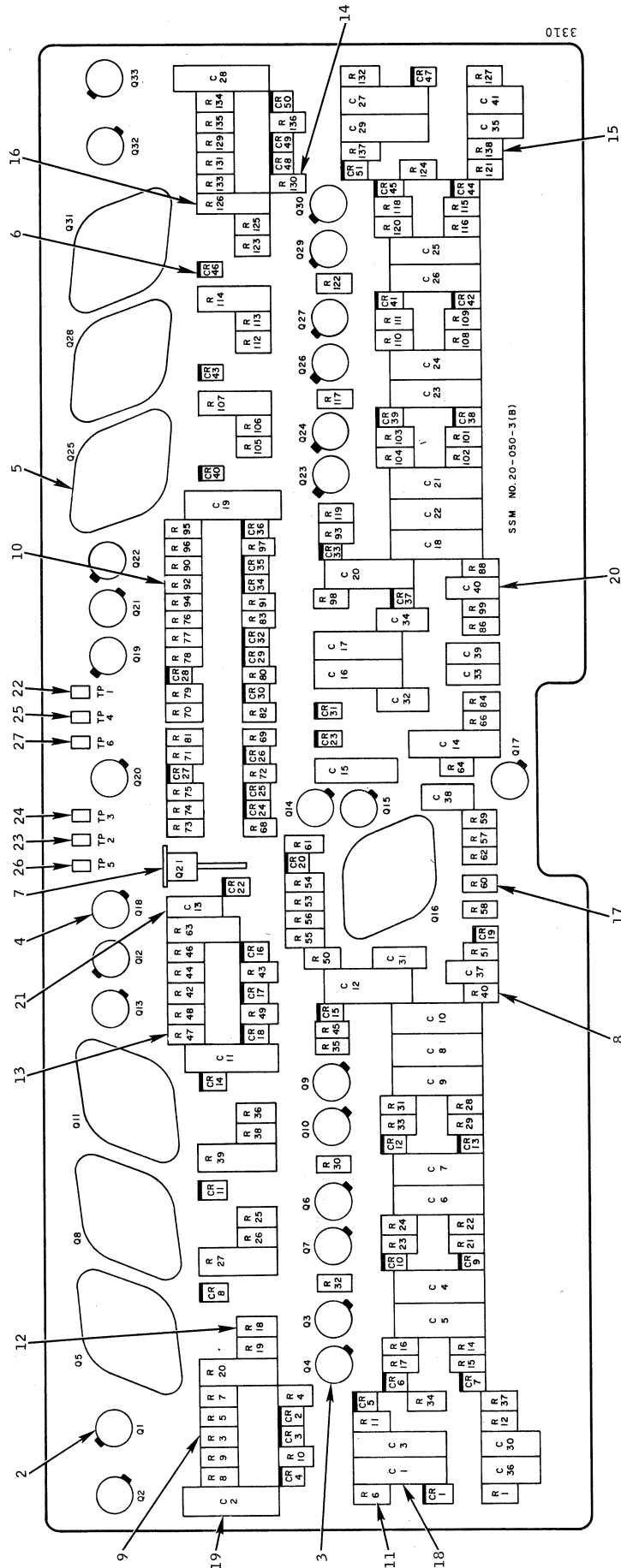

FIGURE 6-6  
Plotter Driver Assembly

FIGURE AND INDEX NUMBER	PART NUMBER	DESCRIPTION 1 2 3 4 5 6	MANUFACTURER	UNITS PER ASSY.
6-6	20-150	PLOTTER DRIVER ASSEMBLY	CalComp	Ref
-1	20-092	. CONNECTOR, P1, P2	CalComp	2
-2	2N377	. TRANSISTOR, Q1 thru Q3, Q6, Q9, Q12, Q13, Q17, Q19, thru Q23, Q26, Q29, Q32, Q33	CBS Hytron Los Angeles, Ca.	17
-3	2N525	. TRANSISTOR, Q4, Q7, Q10, Q14, Q15, Q24, Q27, Q30	General Electric Syracuse, N. Y.	8
-4	2N1377	. TRANSISTOR, Q18	Texas Instruments Dallas, Texas	1
-5	2N392	. TRANSISTOR Q5, Q8, Q11, Q16, Q25, Q28, Q31	Delco Radio Kokomo, Ind.	7
-6	CTP803	. DIODES, CR1 thru CR20, CR22 thru CR51	Clevite Transistor Products Waltham, Mass	50
-7	SDA145	. DIODE, CR21	Motorola Phoenix, Ariz.	1
-8	EB1025	. RESISTOR, 1K $\pm$ 5% 1/2W, R1, R40, R61, R64, R86, R88, R127	Allen-Bradley Milwaukee, Wisc.	7
-9	EB6825	. RESISTOR, 6.8K $\pm$ 5% 1/2W, R3, R42, R69, R70, R75, R78, R81, R82, R90, R129	Allen-Bradley Milwaukee, Wisc.	10
-10	EB2235	. RESISTOR, 22K $\pm$ 5% 1/2W, R5, R44, R92, R131	Allen-Bradley Milwaukee, Wisc.	4
-11	EB1035	. RESISTOR, 10K $\pm$ 5% 1/2W, R6, R14 thru R17, R19, R21 thru R24, R26, R28, R29, R31, R33, R34, R37, R38, R45, R53, R54, R68, R83, R93, R101 thru R104, R106, R108 thru R111, R113, R115, R116, R118, R120, R121, R124, R125, R132	Allen-Bradley Milwaukee, Wisc.	42
-12	EB1525	. RESISTOR, 1.5K $\pm$ 5% 1/2W, R7, R18, R25, R30, R32, R35, R36, R46, R62, R74, R77, R94, R105, R112, R117, R119, R122, R123, R133	Allen-Bradley Milwaukee, Wisc.	19
-13	EB3325	. RESISTOR, 3.3K $\pm$ 5% 1/2W, R8 thru R10, R47 thru R49, R55 thru R57, R59, R71, R79, R95 thru R97, R134 thru R136	Allen-Bradley Milwaukee, Wisc.	18
-14	EB1535	. RESISTOR, 15K $\pm$ 5% 1/2W, R4, R43, R91, R130	Allen-Bradley Milwaukee, Wisc.	4
-15	EB2225	. RESISTOR, 2.2K $\pm$ 5% 1/2W, R12, R51, R66, R73, R76, R84, R99, R138	Allen-Bradley Milwaukee, Wisc.	8
-16	HB5615	. RESISTOR, 560 OHM $\pm$ 5%, 2W, R20, R27, R39, R63, R104, R114, R126	Allen-Bradley Milwaukee, Wisc.	7
-17	EB1005	. RESISTOR, 10 OHM $\pm$ 5%, 1/2W, R58, R60	Allen-Bradley Milwaukee, Wisc.	2
-18	65P10302	. CAPACITOR, .01 UF $\pm$ 20% 200v, C1, C3 thru C10, C12, C14 thru C18, C20 thru C27, C29	Sprague Electric Co. North Adams, Mass.	24
-19	65P10402	. CAPACITOR, .1 UF $\pm$ 20% 200v, C2, C11, C19, C28	Sprague Electric Co. North Adams, Mass.	4
-20	315X5U821K	. CAPACITOR, 820 UUF $\pm$ 10% 500v, C30 thru C41	Erie Resistor Corp. Erie, Pa.	12
-21	150D685X0035B2	. CAPACITOR, 6.8 UF $\pm$ 20% 35v, C13	Sprague Electric Co. North Adams, Mass.	1
-22	119437-D	. JACK, Test brown, TP1	Ucinite Newtonville, Mass.	1
-23	119437-B	. JACK, Test red, TP2	Ucinite Newtonville, Mass.	1

FIGURE AND INDEX NUMBER	PART NUMBER	DESCRIPTION 1 2 3 4 5 6	MANUFACTURER	UNITS
				PER ASSY.
-24	119437-F	. JACK, Test orange, TP3	Ucinite Newtonville, Mass.	1
-25	119437-H	. JACK, Test yellow, TP4	Ucinite Newtonville, Mass.	1
-26	119437-E	. JACK, Test green, TP5	Ucinite Newtonville, Mass.	1
-27	119437-G	. JACK, Test blue, TP6	Ucinite Newtonville, Mass.	1
-28	CSL88000	. MOUNT, Transistor	Circuit Structure Lab Costa Mesa, Calif.	26

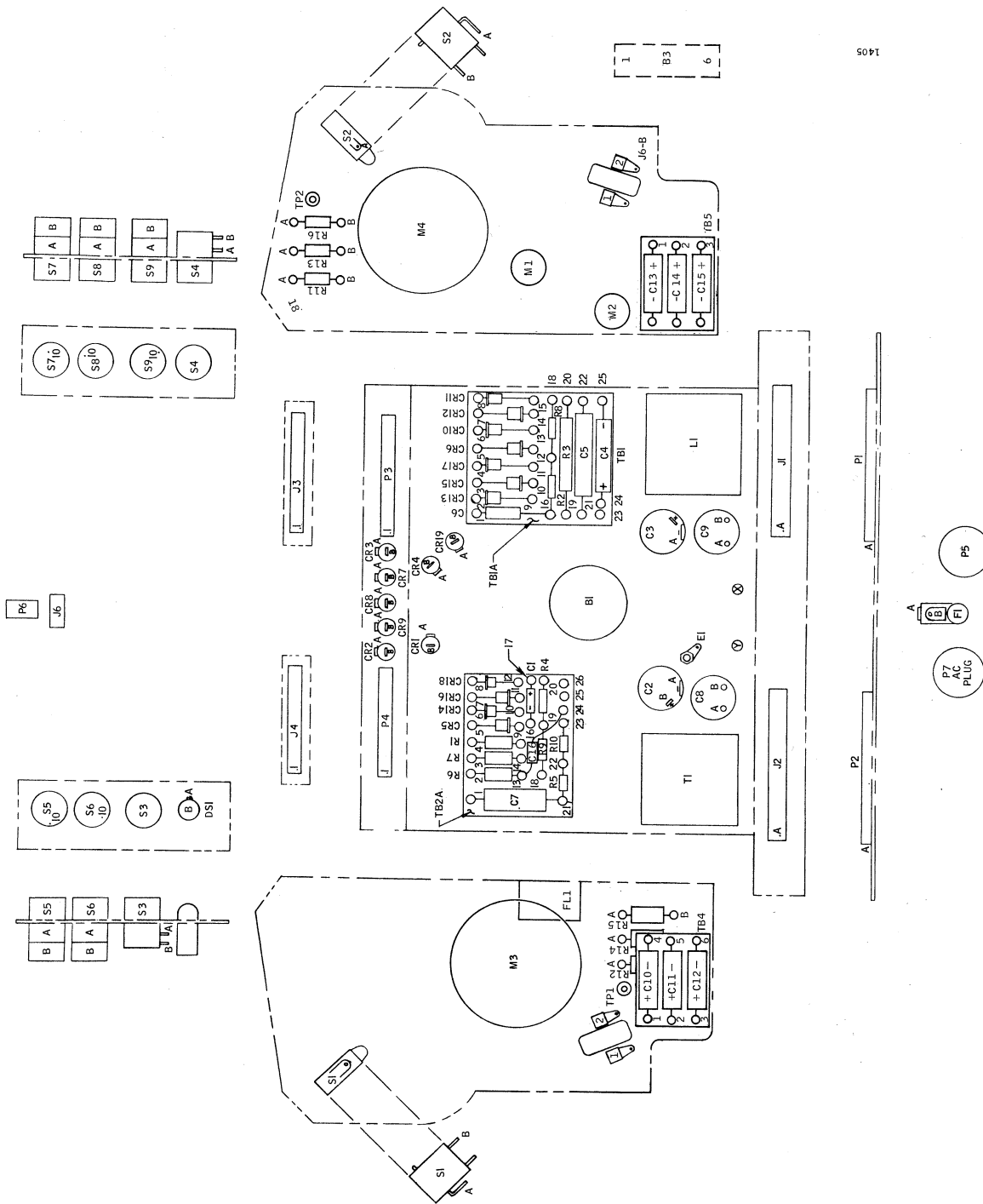

FIGURE 6-7.  
Location of Electronic Parts (Plotter as Viewed From Bottom)

50P1









CALIFORNIA COMPUTER PRODUCTS, INC.  
2411 West La Palma Anaheim, California 92801  
Tel. (714) 821-2011 TWX 910-591-1154